

New York  
State College of Agriculture  
At Cornell University  
Ithaca, N. Y.

---

Library

Cornell University Library  
**SB 603.C4**

**The garden doctor; plants in health and d**



3 1924 003 680 802

mann

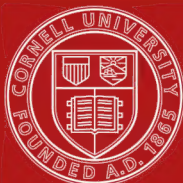

## Cornell University Library

The original of this book is in  
the Cornell University Library.

There are no known copyright restrictions in  
the United States on the use of the text.





THE GARDEN DOCTOR

PLANTS IN HEALTH  
AND DISEASE .

COUNTRY



LIFE



# THE GARDEN DOCTOR

PLANTS IN HEALTH  
AND DISEASE

BY

FREDERICK J. CHITTENDEN

F.L.S., V.M.H.

DIRECTOR, ROYAL HORTICULTURAL SOCIETY'S EXPERIMENTAL GARDENS,  
WISLEY

LONDON :

PUBLISHED AT THE OFFICES OF "COUNTRY  
LIFE," LTD., TAVISTOCK STREET, COVENT  
GARDEN, W.C.2, & BY GEORGE NEWNES, LTD.,  
SOUTHAMPTON STREET, STRAND, W.C.2.  
NEW YORK: CHARLES SCRIBNER'S SONS

MCMXX



## PREFACE

THIS little book makes no claim to originality. It aims merely to give a short and simple account of some of the common troubles met with in gardens, and where they are known, methods of meeting them that have proved effective. These methods have been suggested by many different workers in different lands, and I, no less than every other garden lover, owe a debt of gratitude to them which I take this opportunity of acknowledging. The good there may be in this book is theirs, the faults my own.

FRED. J. CHITTENDEN.

*September* 1920.



# CONTENTS

CHAP.	PAGE
PREFACE . . . . .	v
I. THE PLANT IN HEALTH . . . . .	1
II. CAUSES OF ILL-HEALTH IN PLANTS . . . . .	19
III. NATURE OF FUNGUS ATTACKS . . . . .	42
IV. TREATMENT OF FUNGUS ATTACKS . . . . .	56
V. SYMPTOMS OF FUNGUS ATTACKS . . . . .	65
VI. ANIMAL PESTS OF THE GARDEN . . . . .	102
VII. NATURE OF INSECT ATTACKS . . . . .	106
VIII. GENERAL SYMPTOMS OF INSECT AND MITE ATTACK . . . . .	110
IX. METHODS OF DEALING WITH INSECT ATTACK . . . . .	116
X. INSECTICIDES, ETC. . . . .	132
XI. FRIENDS OF THE GARDENER . . . . .	136
XII. SPRAYING . . . . .	143
INDEX . . . . .	149



## ILLUSTRATIONS

	FACING PAGE
Plants of Furrowed Duckweed . . . . .	22
Skimmer made for clearing Duckweed . . . . .	23
Peach Leaf-curl . . . . .	38
Apple attacked by Bitter-pit . . . . .	39
Rose Leaf attacked by Black-spot . . . . .	44
Rose Stem badly cankered . . . . .	44
Rose Shoot and Leaf attacked by Mildew . . . . .	45
Rose Leaf attacked by "Rust" Disease . . . . .	45
Young Apple Shoots attacked by American Blight . . . . .	66
Apple Shoots attacked by Canker . . . . .	67
<i>Stereum purpureum</i> on Stem of Apple . . . . .	68
Apple attacked by Scab Disease . . . . .	69
Wisley Trap for Turnip Flea Beetle . . . . .	72
A Simple Mouse Trap . . . . .	72
Club Root on Brussels Sprouts . . . . .	73
Celery Fly . . . . .	74
Pea and Bean Weevils . . . . .	74
Winter Moths . . . . .	75
Click Beetles and Wireworms . . . . .	75
Lackey Moth Caterpillars . . . . .	90
Pears cracking . . . . .	90
The Pear Midge . . . . .	91

# The Garden Doctor

	FACING PAGE
Potatoes attacked by Wart Disease . . . . .	94
Orange Rust Fungus on Stem of Briar . . . . .	95
Rose Leaf damaged by Thrips . . . . .	95
Transverse Section of Diseased Daffodil Bulb . . . . .	98
Daffodil Fly . . . . .	99
American Blight . . . . .	106
Daddy-Longlegs . . . . .	106
An Old Device for trapping Slugs . . . . .	107
Common Cockchafer . . . . .	110
Black Currant Gall Mite . . . . .	110
Thrips . . . . .	111
Snake Millepedes . . . . .	111
A Grease Band in Course of Preparation . . . . .	126
Grease Band ready for Use . . . . .	126
A Trap for the Caterpillars . . . . .	127
An Ordinary Hay Band . . . . .	127
Galls on Flowers of the Ash . . . . .	132
The Oak Spangle Gall . . . . .	133
Hover Fly. . . . .	136
Ladybird . . . . .	137
Lacewing Fly . . . . .	137
Spraying Apple Trees at Wisley . . . . .	142
Section of Apple Shoot bored by Caterpillar of the Leopard Moth . . . . .	143



# THE GARDEN DOCTOR

## CHAPTER I

### THE PLANT IN HEALTH

No one can attain an intelligent conception of the meaning of disease unless he appreciates the meaning of good health. In old time, "blight," an expression which covered all mysterious sicknesses, was regarded as punishment imposed by an outraged Deity for some transgression, wilful or unconscious, of laws which the sufferer only imperfectly knew. "Blight" generally is a punishment, and often a thoroughly just punishment: the perfectly natural and inevitable result of the transgression, wilful or unconscious, of natural laws which the sufferer only imperfectly knows. A thorough understanding of those laws, and a rigid abstention on the part of all from transgressing them, would do more to eliminate disease than all the drugs of all the physicians of all the ages. This is a general truth, and applies to our treatment of plants as well as to ourselves. Our

## Health

knowledge of those laws is imperfect, but some of Nature's secrets have been wrested from her, and not all "blight" need now be regarded as beyond our power to avoid.

When a living thing is in health every part of it is performing its allotted task perfectly, and all parts are working harmoniously. As a result, just as with a perfectly adjusted machine, its output reaches its highest efficiency. Let any part of the machinery get out of adjustment and the efficiency at once falls. So with the plant; and, except that it is to some extent self-adjusting, a plant is very similar to a machine: the derangement of any one part will be likely to affect the whole. It is important to remember that its powers of self-adjustment are limited.

The natural aims of a plant are two: to build up and maintain its own body, and to produce offspring. It may, and often does, sooner or later, sacrifice its own body to attain the second object, as in all annuals and biennials, but the first must be gained to some extent before the sacrifice is possible. The designs of the cultivator are not always those of the plant. He frequently wishes to cause the development of some part of the plant out of all proportion to the rest, and the plant strives to respond to his endeavours, but not infrequently at some risk to itself and to its powers of resisting disease. He often selects forms which in nature, because they

## Congenial Surroundings

are less fit to struggle for place than their fellows, would not survive, and by isolating them removes the need for competition. He perpetuates a form which pleases him, but which is less efficient in performing its functions, and which is therefore a weaker and more delicate variety. In seeking to attain his ends he often oversteps the bounds which limit the plant's powers of self-adjustment.

It must not be supposed that plants reach their most perfect development when growing wild, or in their native homes attain their ends with the greatest degree of efficiency. It is, in fact, comparatively rare to find a plant in Nature so placed as to perform all its functions fully. All one can say is that a wild plant is attuned to its environment to a greater or less extent. It has to compete with others, and not infrequently it fails to establish itself under the conditions that suit it best, either because circumstances prevent it finding them, or because other plants oust it from them. The cultivator may often provide better environment than the plant has when growing wild ; then he will secure well-developed plants in good health.

Every species has its own best environment, and every gardener knows that all the varieties even of one species do not thrive alike within the same environment ; possibly even individual plants differ in their precise requirements. Though this is so, and while it would be manifestly impossible to deal

## Plants Breathe

with the likes and dislikes of even the commonest garden plants individually, yet there are certain facts that are true for all plants alike, and, bearing them in mind, the cultivator can approach the attempt to cure or prevent disease with some hope of doing it intelligently.

A plant is a complex organism every part of which has its own functions to perform, and its own special requirements to enable them to be performed. There is one function, however, which is performed in every part of the plant body which is alive. Every part of the plant breathes ; that is, every part of the plant takes in oxygen from the air, and gives out carbonic-acid gas into the air. The gases pass through the delicate walls of the youngest roots, through special openings called lenticels on older roots and woody stems (they can be easily seen on smooth stems as light specks on the bark), and through minute openings in the skin of leaves and young stems, which can be opened or closed at need, and which are called stomata. Provision is made all through the plant by means of spaces between the cells of which it is composed for the air to pass freely to every part. Water-plants obtain oxygen from that dissolved in the water which surrounds them ; all others obtain it directly from the air. Breathing is as necessary to plants as to animals ; fresh air is as necessary to a plant as to a fire. Breathing goes on whenever the plant is active, and the more active

## Use of Breathing

it is the more rapidly does breathing occur. It goes on night and day, and rises with every increase in temperature until the heat is too great for the plant to sustain. By it the plant obtains the energy stored up in its food, and is thus enabled to perform all its other functions. Without it all activities cease, and after a time death ensues. It becomes active with the moistening of the seed ; it finally ceases only with the death of the plant. Any interference with free breathing results in lowered efficiency and in ill-health.

The part of the plant most likely to suffer in cultivation is that which is underground. Few cultivated plants are able to obtain sufficient oxygen from water, and the soil cannot, when saturated with water, hold enough air to supply these parts, and it is upon this fact that the value of good drainage depends ; and to the interference with root-breathing, the evil practices of over-watering and of standing plants for long periods in saucers of water owe their bad results. The breathing of the stem and leaves is, as a rule, only likely to be interfered with when something is deposited on the leaves which tends to choke the openings through which the gases pass.

Before passing to a brief consideration of the special functions of the various parts of the plant, the part temperature plays in plant life may be alluded to. The performance of every function of a plant is more or less dependent upon temperature,

## Heat and Plants

and goes on more rapidly at a higher than at a lower temperature. A temperature of, say, 60° F. would not, however, hasten the performance of any one function to the same extent in all plants alike, nor does the most efficient performance of the separate functions in any one plant all occur at the one temperature. The best temperature for a plant is a compromise between the different temperatures at which its several functions reach their most efficient working, and it varies with different plants, and with the same plant at different periods in its life. There are, unfortunately, no observable characters by which one can tell what range of temperatures will best suit a given plant, and only experience can decide, although indications may be obtained by a knowledge of the distribution of the plant and of its relationships. A higher or a lower temperature than that which suits the plant best is bound to produce ill effects in it. A very high temperature (usually anything over about 140° F.) causes death, so also does a low temperature; but whereas most plants die at about the same temperature in the upper range, some can bear a far greater degree of cold than others. The exact degree will depend partly upon the condition of the plant, but very largely upon its nature.

We turn now to the special work of the different parts of the plant. The root has two general functions. It absorbs the water required and certain

## Root Work

substances used by the plant in building up its body, and it fixes the plant in the soil.

The younger parts of the root have thin, delicate walls through which (although no visible holes are present in them) water and substances dissolved in it may easily pass. The extent of surface of these parts of the roots is increased by the outgrowth of many cells so as to form delicate projections. These outgrowths are called root-hairs, and though their life is short, they are continually replaced by new ones as the root lengthens and branches, and they always occur within a short distance of the tips of the roots. All the water, etc., absorbed by the plant must find its way through the surface of the root-hairs or of the delicate roots which produce them. The useful water in the soil forms a film over the surface of the particles of which the soil is composed, and from these particles certain substances are dissolved. In order to obtain the water the root and root-hairs must be in close contact with the soil particles.

Chemical analysis of plants has shown that the following elements are universally present in them, viz. carbon, hydrogen, oxygen, nitrogen, sulphur, phosphorus, calcium, magnesium, potassium, iron, chlorine, silicon, and sodium. Experiments have shown conclusively that the first ten in this list are essential, the others needless or merely accessory. Except carbon, all are obtained from the soil in

## Chemical Constituents

solution. The first six are constituents of the living stuff itself, the remaining four each play their several parts, potassium assisting sugar formation, iron being essential in the formation of the green colouring matter, and so on. If either of these chemical elements is present in too small quantity in a soluble form in the soil the growth of the plant is interfered with. If certain of them are present in too great quantity as compared with the others either part of the plant is encouraged to develop at the expense of the other parts, or parts are injured or destroyed. If the soil solution is too strong, absorption of water by the plant is retarded or actually prevented. Only when the soil solution contains sufficient but not excessive quantities of soluble salts combining the essential chemical elements can water and earth-salt absorption go on normally and the plant be supplied with the requirements for healthy life. The rate of absorption of water and earth-salts is to a large extent governed by the rate at which each constituent of the solution is used by the plant, or, in the case of the water, got rid of.

Ideal conditions for absorption by the root are provided when the water supply is arranged so that every soil particle is kept bathed in a weak solution of all the earth-salts which the plant requires, while the spaces between the particles are filled with air, when the soil temperature is sufficiently high, for the rate of absorption rises with the increase of



## Firm Planting

temperature up to about 90° F. ; and when the delicate root-hairs are in intimate contact with the soil particles.

The intimate contact of the root-hairs with the soil particles effects the fixing of the plant, which is the other function of the root. Frost, flooding, ill-advised soil cultivation, bad planting, such, *e.g.*, as "hanging plants up," winds, burrowing animals and the like, may break the contact or render it difficult to effect, as may readily be seen.

The coarseness or fineness of the root-fibres and other structural peculiarities, into which we cannot enter here, are in the main connected with the kind of soil, clay, sand, etc., in which the plant is most at home. The firmness of the soil also influences the kind of shoot-growth made, for it modifies the water supply. The firmer the soil the more compact the growth.

The stem, be it long or short, simple or branched, has two main functions : to convey materials from place to place in the plant and to produce leaves and place them where they can make the best use of the light.

A section across a stem shows, as a rule, a central pith surrounded by a cylinder of wood ; this again by soft inner bark or bast with probably fibrous and green tissue outside of it, and lastly, either a thin skin or a layer of cork. Between the wood and the soft bast lies a very delicate ring of cells, called the

## Stem Structure

cambium, which by its division adds to both the wood and the soft bast and so thickens the stem. This part of the stem is really a series of cords lying side by side, each consisting of wood inside, cambium, and soft bast. In other plants there is no ring: instead, the bundles of wood and soft bast tissue are scattered about, forming long cords through the stem tissues, and no cambium is present. In any case, one end of the cords or their branches lies in the leaves where the veins are made by them, and the other in the roots, where they reach the uttermost rootlets.

The wood consists of fibres for strengthening, and long tubular vessels along which water or earth-salts are pushed and drawn up from the root to the leaves. All water passes up the wood.

The soft bast consists mainly of peculiar tubes along which the food made in the leaves passes to any part at which there is a demand for it, arising either from its being used to form new tissues, or in breathing, or through its storage.

There is therefore an upward passage of water containing earth-salts, and a downward passage of water containing manufactured food, and each has its own proper channels. The channel for the water and earth-salts lies toward the inner part of the stem and the upper side of the leaves; the channel for the food on the outer part of the stem (just on the inner side of the bark) and along the lower side of the leaf-veins. Have you noticed aphides feed on the lower

## Stem Work

surface of leaves where the food is most easily reached ?

The second function of the stem will be more readily appreciated after we have briefly discussed the functions of the leaves. All leaves are produced in buds and in age-order, the younger nearer the apex of the stem bearing it. The stem carries them into the light, and the spaces at which the leaves are set may be more or less lengthened as the stem grows in order to effect this, or the stem may twist between the leaves for the same purpose. The arrangement of the leaves on the stem and their disposal are both connected with the need for light.

The special functions of the leaf are also two : the making of food and the getting rid of water. Both these functions, as we shall see, involve the passage of gases into or out of the leaf, and this is effected through the curious pores called stomata which are found in the skin of the leaf, mostly on its under side. These pores are surrounded by two guard-cells, which open when the plant is fully supplied with water or when it is exposed to light, and which tend to close as the water supply or the light fails, and may close completely.

Food-making is a power which, of all living things, green plants alone possess. The raw materials for it are water and earth-salts, which are obtained by the roots, and carbonic-acid gas, which passes from the air through the stomal openings into the leaves.

## Food-making

(The plant, of course, produces carbonic-acid gas inside the cells themselves in breathing, but far too little to supply its own needs in food-making. It therefore draws upon that produced by animals and by fires.) The process of food-making is a very complicated one, but the first visible product is starch. This is made from the water and the carbonic-acid gas, the former being split up into its constituent oxygen and hydrogen, the latter into carbon monoxide and oxygen. The two oxygens are no longer wanted and pass off into the air. The carbon monoxide and the hydrogen are caused to combine together to form sugar, which is further changed to starch.

To do this work of food-making power is wanted, just as it is to do any other work. We have already pointed out that a certain temperature is required to enable any work to be done, but heat alone will not supply the energy for doing this special work : the only form of energy which can be used is derived from sunlight or light containing similar rays. When the rays of light fall upon a leaf they do not all pass through it, but some are arrested by the green colour which is so characteristic of foliage (it is present even in purple leaves, such as those of the purple beech or purple plum). The rays so absorbed are used by the living stuff of the leaf as a source of power, and only when light falls upon a green leaf can food be made. Anything that interferes with the falling

## Value of Light

of light upon the leaf reduces the power at the disposal of the leaf ; even glass of ordinary kinds has that effect.

Curiously enough, very bright light has a destructive effect upon the green colour, but the plant has the power of protecting it from destruction by removing the grains containing it from the direct rays of the sun when these threaten it too severely. Plants which naturally grow in more or less deep shade are able to make use of even the faint light that reaches them, but it may be so faint that although they can make enough food by its aid to sustain existence, yet they make insufficient to enable them to flower.

The making of sugar may be looked upon as the beginning of the food-making process, for plants, no less than animals, require other foods. The next step in building the more complex and valuable foods is the addition of nitrogen to the carbon, hydrogen, and oxygen of the sugar. The nitrogen is derived from the soluble nitrates and salts of ammonia absorbed with the soil-water. After this combination is effected, sulphur from sulphates and phosphorus from phosphates, both of which have similarly come from the soil, must be brought into chemical combination with the other elements before the material is available out of which the living stuff itself is made. The steps by which these combinations are brought about, and the conditions upon

## Loss of Water

which they depend, are too indefinitely known to warrant any description of them in a simple account such as this, and it must suffice to say that the iron, potash, calcium, and magnesium which enter the plant and are known to be essential to it, are of use in promoting the chemical changes which result finally in the building up of the living stuff of the plant, and in its subsequent changes which are expressed in what we term living activities.

The second special function of the leaf, the passing-off of water, is necessary in order to concentrate the various earth-salts sufficiently to make them useful, and to keep the plant cool.

The solution taken in from the soil is as a rule, and in the vast majority of plants, exceedingly weak. In order to obtain enough earth-salts much greater quantities are therefore taken in than are necessary to distend the cells and to provide water, as one of the raw materials for food-making, and the surplus must be got rid of.

The burning rays of a vertical sun in a cloudless sky would soon raise the temperature of the plant-body above what the living stuff can withstand but for the fact that much of the heat is used in evaporating water which passes off through the pores in the leaf, which we have already mentioned.

Water is essential to all plant activity. The living stuff of the plant can have no active existence unless it is saturated and distended with water ;

## Water Supply

nothing enters or leaves the plant unless it is dissolved in water ; water is the vehicle by which all substances (except the air in the spaces between the cells) is conveyed from place to place, and even the oxygen and the carbonic-acid gas are brought into contact with the living stuff dissolved in water ; and water is one of the necessary raw materials for food-making.

To obtain the most light and to get rid of as much water as is necessary or as the plant can afford, are the problems which face every plant in the determination of its leaf structure, and many and wonderful are the devices for meeting the two different ends, the one demanding a large surface, the other often rendering a contracted one absolutely essential. Contrivances for getting rid of enough but not too much water determine more than anything else the form and habits of a plant. It is not too much to say that it is possible to tell more about the conditions under which a plant should be cultivated (except as regards the temperature) by a consideration of its foliage than by anything else, and the most successful plantsman will be he who best fits conditions, by choice of compost, regulation of atmospheric moisture, and use of the water-pot and other means of regulating soil-moisture, to suit the water requirements of his charges. There are more plants murdered by injudicious use of the water-pot than by any other means, and there is no better

## Watering

test of the efficiency of a gardener than that imposed by the operation of watering. A gardener who studies the structure of his plants with a view to realising their water requirements, and has the opportunity and gumption to regulate his treatment accordingly, will be little troubled with plant diseases.

This is not the place to describe the various modifications of leaf-form devised to regulate water supply, but it should be clearly realised that large-leaf surface, dry air and draughts, bright light and high temperature, increase the amount of water lost by the foliage, and the loss can be made good only by absorption of water by the roots. A small amount of foliage, moist air, shade, and low temperature diminish the loss. Finally, it may be said that the plant can, by opening or closing the pores in its leaves, regulate the loss to a considerable extent, and that it can within certain limits alter the structure of its foliage to suit changed conditions, as long as the conditions are brought about gradually, as in the process of "hardening off." Different plants are able to make these modifications to different extents, and some only to a very slight extent.

The remaining organs of the plant, the flower, fruit and seed, are connected with reproduction, and broadly speaking, if the other organs are in good working order these will do their work efficiently. Flowering is usually connected with a quiescent



## Food Storage

rather than an energetic state, and flower production is usually greatest when the balance between water supply and food store is in favour of the latter ; *e.g.*, slightly pot-bound plants flower more freely than over-potted ones.

More food is usually made by a plant in health than is necessary for its immediate needs, and this is stored in some part of the plant either for its own needs in the future, as the starch in the medullary rays of the vine stem, and the sugar in the beetroot, or to give its offspring a start in life. Such food stores are naturally attractive to parasites, and not a few plant pests thrive upon them to the detriment of the plant's future, or the strangling of its progeny at their birth.

The final result of all the plant's activities, and dependent upon their due performance, is growth. It is a complex process and dependent on a sufficient supply of manufactured food made by the foliage, enough water to distend the cells to their full extent and to keep them distended (and therefore, probably, most active at night), a temperature suitable to promote all the necessary chemical changes (varying with each different kind of plant), a supply of oxygen for breathing purposes, and the absence or prompt removal of all substances detrimental to the well-being of the plant.

The kind of earth-salts available has some influence upon the kind of growth produced, and

## **Effect of Manures**

upon the localisation of growth. Thus soils rich in combined nitrogen (whether naturally or by the addition of manures) promote the growth of foliage, perhaps at the expense of flowers; plants growing in soils where available potash is abundant usually store more starch or sugar than where it is only barely sufficient; while abundant supplies of phosphates appear to encourage flowering, and especially fruit and seed production. These are, however, but examples of the power of response to changes in their surroundings possessed by plants, and might be multiplied almost indefinitely for each variation in all the surroundings which we have considered.

## CHAPTER II

### CAUSES OF ILL-HEALTH IN PLANTS

JUST as a plant is in perfect health when all its organs are perfectly attuned to its surroundings, and no one function outpacing the others upon which it partly depends, but all concerting in harmony for the common good, so when anything occurs beyond the power of the plant to adjust itself to and discord arises, ill-health will supervene and the whole suffer.

The discord may be due to changes in the plant itself, possibly perfectly natural and occurring in the due sequence of its development, or it may be due to changes in the environment. In the latter we have to include not only the soil, water, atmosphere, temperature, and light, but also its living neighbours, and especially such as are likely to prey upon it among animals and fungi.

The changes which occur naturally in the plant itself are generally looked for, and are less deplored than those which bring about disease through acting from without. A good example is provided by those

## Exhaustion

plants which "wear themselves out" by producing seed; all the food made and the water absorbed are directed to perfecting parts which are unproductive so far as the individual is concerned. The flowers, fruit, and seeds are either not green at all or consume a far greater quantity of food than their small amount of green tissue enables them to produce. In them the individual actually dies of starvation, starving itself to give its offspring a good start in life. Annual and biennial plants are such, and not a few perennials delight us for a time and are no more, for the same cause. Who has not deplored the loss after its brilliant display of such a mule pink as "Napoleon III." ? Yet it is not doomed to die if we prevent it flowering when it wants to, but will then give us plenteous shoots for propagation. So too may the life of annuals be prolonged by restricting their flower production or removing their seed pods before they develop too far. Indeed, in such cold regions as Central Siberia even such confirmed "annuals" as the common shepherd's purse outlive more than one growing season.

Interesting as this phase of plant-life is, more important to the cultivator is the set of troubles due to external factors such as unsuitable surroundings and attacks of living agents. A study of the subjects briefly outlined in Chapter I. will indicate where there are chances of the surroundings being faulty,

## Effect of Grass on Trees

but in addition to those mentioned there, the presence of substances detrimental to plant growth, either in the soil or in the air, have to be dealt with, and in a few instances in the cultivation of garden plants we have cases where plants actually come into competition with one another quite apart from overcrowding through too close planting. We may deal with these first.

One of the most frequent checks imposed upon trees is the presence of grass about their trunks. It is especially seen when young fruit trees are planted in grass, is most marked when the grass completely covers the ground, but is still seen when several feet are kept clear around them. Experiments seem to show that it is through no direct interference with water, air, or earth-salt supply that the marked check to growth is caused, but rather to the production of some substance deleterious to the trees by the grass, or the decay of the remains of the grass, roots, etc. The remedy is to remove the grass, and the result of this treatment is, so long as the poisonous effect has not been in operation too long, rapid.

A second competitive effect is often seen in water where water-lilies and other aquatic flowering plants are often damaged by being smothered with the thready green masses of "flannel weed," which grow with extraordinary rapidity. This flannel weed will grow in any exposed piece of water, but is readily

## Flannel Weed

kept down in wells and tanks by covering them with an opaque cover, as it depends upon light. The ordinary methods of weeding, or rather raking out of the stuff, are only partially successful. Fish often eat considerable quantities of it, and if a sufficient number can be kept in the water, they will do much to keep it in check. If it still persists, then the copper sulphate treatment should be applied. The quantity of water in the pond is estimated.<sup>1</sup> For each ten thousand gallons put  $2\frac{1}{2}$  oz. copper sulphate (blue stone or blue vitriol) into a coarse canvas bag and draw the bag by means of a rope across the pond in every direction until the whole of the copper sulphate is dissolved. The very dilute copper sulphate solution will kill the algae (or "flannel weed") without harming fish or water-lilies. It may have to be used again during the season, but in still water often keeps the algae from growing for a long time.

The third case in which plants come into competition is on lawns. Here the troubles are usually of two types, the growth of broad-leaved weeds and the growth of moss. The composition of mixed herbage is always determined by two factors—the opportunity various plants have of gaining a footing,

<sup>1</sup> Multiply the average breadth in feet by the length in feet and the product by the average depth in feet. This will give the number of cubic feet contained in the tank or pond. Multiply this result by  $6\frac{1}{4}$  (or 6.232 to be more accurate) and the product will be the number of gallons the pond holds.

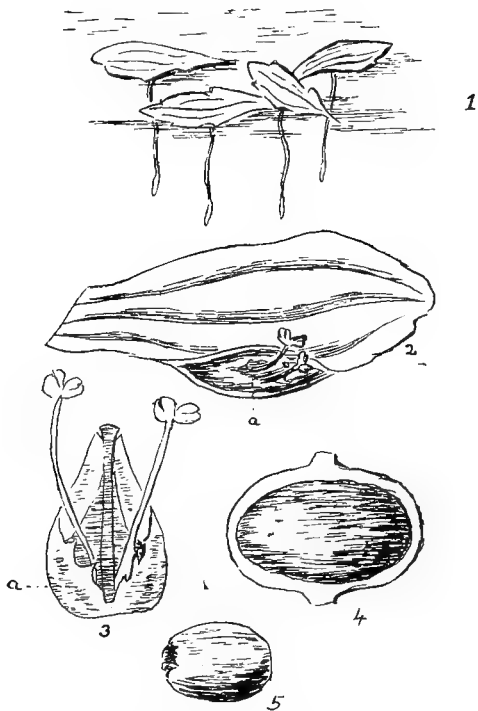

PLANTS OF FURROWED DUCKWEED (*Lemna trisulca*).

1. Floating on water. 2. A plant magnified, and in flower at *a*. 3. A flower extracted from the slit in which it is laid—*a*, the membranous bag. 4. A fruit. 5. A seed.

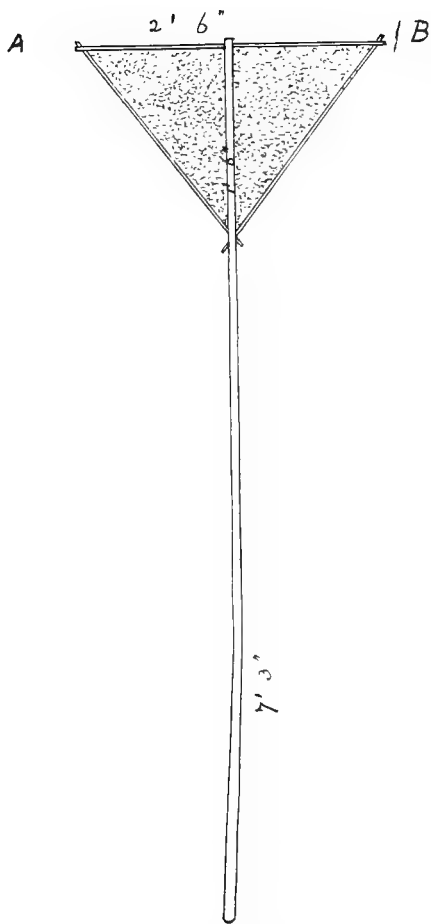

SKIMMER MADE FOR CLEARING DUCKWEED.



and the nature of the existing conditions. On a lawn we usually place the plants we desire, by using turf containing grasses suitable for the purpose, or by sowing a mixture of seeds free from weeds. If the conditions are favourable to the grass all goes well, but if they are unfavourable and bare patches arise, weeds and moss are apt to establish themselves; and if the conditions are then more favourable to the weeds or the moss, the grass will gradually be killed out and its place taken by the more favoured tribe.

The application of sulphate of ammonia favours the growth of grasses more than does any other manure. It also acts detrimentally upon broad-leaved plants if strewn upon them, and where time permits there is no better method of killing them than by putting as much sulphate of ammonia on their crowns as would cover a sixpence. Where this cannot be done sulphate of ammonia should be distributed over the lawn at the rate of  $1\frac{1}{2}$  cwt. to the acre ( $\frac{1}{2}$  oz. to the square yard, or 1 lb. to the square rod). It may be mixed with dry soil and spread more readily thus than by merely throwing it on broadcast. More should not be used and may do harm. Spring is the best time to apply the manure.

The presence of moss is a symptom that conditions are not favouring the grasses. At least three different causes may lead to the production of this symptom, viz. lack of drainage, sourness of soil, and

## Moss on Lawns

poverty of soil. The remedy for lack of drainage is obvious, and the constant presence of a superabundance of water in the soil often results in sourness. Sourness is probably due to the production of organic acids by the action of bacteria, which work best in the absence of air, and of a suitable base to combine with the acids. The cause of its production being removed it is necessary also to remove the acid. Soil acidity may be discovered by a simple test. A fair sample of the soil is obtained by taking portions from various parts of the ground, mixing them thoroughly (best done by allowing them to dry and crumbling them up together), and taking a sample of the bulk. This sample is moistened with pure water, and a piece of blue litmus-paper is laid in close contact with the moist soil and left for half an hour under a tumbler. If at the end of that time the litmus-paper has acquired a distinctly red tint the soil is acid. The remedy for soil acidity is lime, and a dressing of powdered chalk will often help to encourage the grass and oust the moss. Use it in autumn at the rate of 1-2 tons to the acre ( $\frac{1}{2}$ -1 lb. to the square yard, or 15-30 lbs. to the square rod).

The third source of a mossy condition is poverty of soil. This is always likely to arise where the lawn is mown regularly and the clippings removed, and such lawns benefit by an annual spring dressing of good sifted loam, sandy loam answering the

## Sour Soils

purpose well. This may be applied at the same time as the sulphate of ammonia, and a dressing of superphosphate is often of great benefit, the latter being used at the rate of 2-4 cwts. to the acre ( $\frac{3}{4}$  to  $1\frac{1}{2}$  oz. to the square yard, or  $\frac{1}{2}$  to 3 lbs. to the square rod). No definite instructions for soil treatment to suit all places and all kinds of lawns can be given, but treatment such as has been advised will meet most cases.

A second sort of soil acidity has to be reckoned with in great centres of population where acid from chimney fumes is brought down by the rain. Lime will not protect plants from damage by this, and only the use of the most acid-resistant grasses like *Poa annua* is likely to result in the growth of even a moderate lawn. These fumes, and the tarry deposit which collects on the leaves and owes its presence to the same source, do irreparable damage.

While dealing with lawns another set of troubles may be referred to—the difficulties met with in growing grass under trees. Comparatively few grasses are attuned to the dim light that reaches them under the shade of trees—most require the full light of the open meadow. Of these few but one or two are fitted for the peculiar treatment lawns necessarily undergo, *Poa nemoralis* being the best of them, and choice must fall upon them for a grassy covering in such places. Even these, however, are apt to be killed out, for not infrequently their

## Honeydew

leaves become covered by a sticky fluid called honeydew, which is produced by aphides or scale insects living upon the trees above them, and which drops down, effectively closing all the pores on their leaves through which the various gases should pass, and causing their suffocation or starvation. Lime trees, while by no means the only ones, are particularly troublesome cover for shady lawns because of this. Any remedy beyond a frequent spraying of the grass with water would be very difficult to apply, and entail unreasonable expense.

Honeydew often falls upon other plants from aphides and their allies, and damages them in a similar way, and also forms a medium for the growth of a set of fungi called black moulds. These black moulds are not directly destructive to the plant, are wholly superficial, and may readily be rubbed off the leaves or fruits on which they are found. They are, however, very disfiguring, and worse still, they obstruct the light so that the process of food-making is seriously interfered with. The remedy is of course to attack the insects which are the source of the honeydew and to cleanse the plants by spraying or sponging with water or soapy water.

Soil acidity is a frequent cause of ill-health in other plants than grasses. As has already been pointed out, it is very liable to arise when drainage is insufficient, but it also occurs in soils devoid of lime and in soils to which organic manures have been

## Test for Lime

continuously added. It is indeed well to maintain a sufficient quantity of carbonate of lime in the soil to counteract any tendency to sourness, and soil may easily be tested to see whether enough is present.

To carry out the test, take samples from various parts of the plot to the depth to which cultivation is usually carried. Crumble them up together until they are thoroughly mixed, and then place part of the soil in a tumbler with ordinary tap water to wet it thoroughly. Pour upon it a little spirits of salts (muriatic or hydrochloric acid). If noticeable effervescence occurs the indication is that the soil contains sufficient lime, but if there is no effervescence it is desirable to add lime. It is not at all infrequent to find that soils with a chalky subsoil are deficient in lime so far as their upper layers go, so that even they may need liming. Lime is added in a variety of ways. Chalk, powdered so as to be distributed evenly, is best suited to light soils, air-slaked lime to heavier; but where soil pests are to be killed powdered quicklime, distributed at the rate of half a bushel to the square rod in autumn and immediately forked in, is best. Gypsum, marl, or crushed shells are all useful mild forms of lime best used on light and sandy loams. Gas lime of the old type is now rarely procurable, and if used entails the lying idle of the soil for a longer or shorter time.

The presence of lime in the soil is detrimental to most rhododendrons, heaths, and the like, and

## Weeds of Sour Soils

where these are intended to be grown it should not be added.

Soils which are sour often develop a growth of moss upon them very quickly in moist weather, and certain weeds grow well which are absent, or almost so, from soils containing a sufficient supply of lime. Among these weeds sheep-sorrel (*Rumex Acetosella*) and spurrey (*Spergula arvensis*) or dodder, as it is called in some places, but quite distinct from the true dodder, are the commonest, and liming the ground does much to keep these weeds in check. Lack of drainage is often similarly indicated by weeds, the common horse-tail (*Equisetum arvense*), called mare's-tail in some places, and Coltsfoot (*Tussilago Farfara*) being common examples of such stagnant water indicators. With these again efficient drainage does much to check their spread.

Sour soil checks the growth of many plants and encourages the growth of pests of various sorts, at the same time laying the plants open to the attack of the pests to an extent unknown on soils in better heart. The acids may render it more difficult for roots to absorb the necessary water; their presence may actually poison the plants, while the presence of water in the soil where air should be causes the suffocation of roots, and therefore a cessation of the water supply.

This is not the place to point out how drainage should be effected, but we may refer to one or two

## Drainage

causes which militate against good drainage even when it is thought to have been efficiently provided. Drains in the open ground often become filled with tree roots or broken in their course so that the channel becomes filled with earth and choked. The air supply to the roots of plants in pots is not infrequently interfered with by the use of dirty pots, of pots much too large for the plants in them, by worms carrying earth into the drainage, and by standing plants over the week-end with water about half-way up their pots so that they shall lack nothing. The use of fancy pots in which to stand the ordinary flower-pots often leads to the same trouble, which usually manifests itself by the tips of the leaves becoming brown. Glazed pots render watering much more difficult than ordinary flower-pots, and novices often come to grief in using them, as did the artistic (?) individual who painted the flower-pots with a bright green paint and so filled up all the pores through which air was wont to pass.

Plants in ill-drained and sour soil often indicate the condition by the unhealthy yellowish tint of their foliage. Pallor is almost always a symptom of ill-health, and if accompanied by stunted growth and by brown tips to the leaves, will usually be found to be due to interference with root activity through ill-drainage. Some other causes leading to interference with root-action produce similar symptoms, but that is the most common.

## Acid Water

Some pests, such as the troublesome leather-jacket, the grub of the daddy-longlegs, or crane-fly, are more prevalent in wet than in properly-drained soils.

In manufacturing districts water standing before use for watering and syringing plants not infrequently absorbs poisonous fumes of sulphurous acid and chlorine from the air, and plants on which it is used naturally suffer. Some good may be done by placing lime in the tanks to neutralise these substances. The same fumes often do damage to the foliage by entering the pores of the leaves with the oxygen and carbonic-acid gas or by being dissolved in the drops of water which exude from the tips or teeth of many leaves when the air is moist. The cells with which the poisons come in contact are killed, and brown spots occur in the leaves or along the margins. At times arsenical fumes escape from smelting works and do much damage. Similar damage was not infrequent when the old flue-system of heating was in vogue and fumes from the flue escaped into the houses, and at the present time sufficient care is not always taken to ensure that fumes from the stoke-hole are effectively excluded from the house. Gas and fumes from gas lamps are equally detrimental. We have had cases recently brought to our notice of similar poisoning by fumes from creosoted wood and the like.

When these causes are operative it will be found



## Burning

that many different plants are suffering from the spotting, though the spots are not all of the same shade of yellow or brown, whereas a fungus attack will be confined to one or at most a few kinds of plants in it, as with that of most animal attacks except perhaps red spider, when the pests themselves will be evident to the careful observer. This will serve to distinguish the source of this trouble from that of insect or fungus attack in most cases, but not from the trouble known as burning or scalding.

The escape of coal-gas or acetylene from leaks in underground pipes not infrequently leads to the death of roots of trees and shrubs in the vicinity.

Burning or scalding is characterised by the presence of white, yellow, or brown spots on the foliage (only occasionally at the edges) and is most frequent on leaves of rather thin texture. It occurs also on grapes. It is often attributable to defective glass (*i.e.* glass of uneven thickness, or containing bubbles) concentrating the sun's heat on certain spots, and plants placed in these spots will suffer. Similar results follow even a short time of water shortage in some delicate-leaved plants such as Primulas and Begonias, especially when the air as well as the soil is dry, or lack of ventilation with vines, etc., or syringing with a falling temperature instead of with a rising one, which is particularly detrimental to orchids and leads to the black-spotting of the foliage or pseudo-bulbs. Exactly

## Value of Potash

how this scalding arises is not very clear, but it is probably due sometimes to a great local rise of temperature leading to the too rapid withdrawal of water from the cells, and at others to a rapid fall in temperature perhaps bringing about a similar result, and in any case leading to the death of cells in circumscribed areas in the leaf. The preventive must be found by a consideration of all the circumstances and the removal of the cause, adjusting matters so as to maintain a proper degree of moisture in the air in relation to the temperature of the house and the amount of light the plants are receiving. This is, of course, difficult to achieve for every plant when many kinds of plants are grown in one house, and it then becomes a question whether attempts should be made to cultivate any others than the more accommodating ones, or in the alternative to restrict the inmates of the houses to some special favourites with similar requirements.

Returning now to the effect of the chemical constitution of the soil on health, we find that an excess of any or a deficiency of the ordinary earth-salts produces more or less definite symptoms. We have already pointed out the more obvious parts played in plant nutrition by the principal chemical elements, and the result of a deficiency of any one of them is readily seen. It only remains to say that deficiency in potash supply lays many plants open more readily to fungus attack, and that deficiency

## Avoid Excess

of phosphates is often recognisable by a purplish tinge in the foliage of grasses, especially of barley and the like.

An excess of nitrogen leads to a lush, sappy growth which falls ready victim to fungi and is much more liable to damage by frost than more sturdy tissue. Such growth is characterised by a deep green colour, large watery foliage, and often long internodes, which are not, however, thin. It often follows the too liberal use of organic manures or nitrate of soda and sulphate of ammonia. Soils which grow chickweed and fat-hen (*Chenopodium album*) vigorously are usually sufficiently supplied with nitrogen.

Excess of lime is characterised by yellowing of the foliage, which may be of rather small size, and may be entirely or only partially devoid of green colouring matter. The growth is usually sturdy and the internodes short. The lack of green colour of course checks food-making more or less completely, and the result is disastrous to the plant. It may be cured by the application of sulphate of iron to the soil at the rate of 2 oz. or so to the square yard. Roses and laurels frequently show this disease, which is termed chlorosis, when growing in chalky soils.

A curious cause of infertility, not marked by any very characteristic symptom in the plants except general tardiness in growth, is found when the amount of magnesia present is in excess of that of

## Liquid Manuring

lime. This can be discovered only by careful chemical analysis, and is remedied by redressing the balance by the addition of lime.

Of the evil resulting from the presence of various poisonous metals in the soil we need not write except to warn against the addition of too much borax (which has been recommended as an antidote for flies and which does little harm when only small quantities are used), and against the possible danger of the too free use of arsenical poisons, which has been reported to have resulted in considerable harm in some parts of America.

Before dismissing this matter the use of too strong solutions of fertilisers as liquid manure should be mentioned. One ounce of a fertiliser dissolved in a gallon of water is amply strong enough, and half an ounce is usually better. If the solution of earth-salts in the soil becomes stronger than usual the plants have difficulty in absorbing water, and may actually wilt on account of it, and harm rather than good results from the application. Acting on the fallacious reasoning that if a little does good, more will do better, amateurs not infrequently cause considerable damage by using too much fertiliser in an excess of zeal and a laudable desire to excel. Plants with delicate foliage suffer most, spots similar to those produced by burning appearing on the leaves, but even more robust plants are apt to drop many of their leaves. The difficulty of absorb-

## “Drawn” Plants

ing the water from the strong solution acts exactly as an actual lack of water does, and produces precisely the same symptoms. If through inadvertence too much of a fertiliser has been used, the best thing to do is to water freely; if the plant is in a pot, stand the pot in a considerable volume of water for a time so as to wash the excess out, taking care that all excess of water is drained away when the pot is removed from the vessel in which it has been standing.

Excess of water combined with a rather high temperature leads, just as excess of nitrogen does, to the production of sappy unprofitable growth, less dark green, however, than nitrogen-forced growth. When these two conditions combine with deficiency of light, or when light is deficient and only a moderate supply of water and heat are available, a diseased condition known as etiolation is produced.

In extreme cases, such as can be seen in the stems of a potato allowed to grow in darkness, no green colour at all is developed, the foliage fails to broaden, and the stems become greatly elongated, sappy, and lacking in woody fibre. When less marked the plants show all these symptoms to a slighter extent and are said to be “drawn.” The “drawing” is seen in window plants on one side, and has the result of turning the foliage so that it can get the whole of the light available. This kind of “drawing” can be avoided by frequent turning of the pots so that all sides of the plant are equally illuminated in turn.

## Overcrowding

Overcrowding, too close planting or seed-sowing, standing plants too far from the glass, allowing their more vigorous neighbours to overshadow them, shading them and forgetting to remove the shade, are all common ways of causing etiolation. The checking of food-making in such plants need not again be referred to, but it may be worth while to point out the especial danger of permitting the condition to overtake young seedlings which have only the slender store of food laid up for them in the seed to fall back upon. They may be completely ruined by it, and in any case their delicate tissues will be laid open to attack by damping-off fungi.

Etiolation may also be induced in greenhouses by keeping the temperature too high in winter and urging growth when the light is naturally dim and of but short duration. It is a wise rule that delays seed-sowing until the "turn of the year" when the light begins to increase. Etiolated growth is almost, and sometimes quite, useless to the plant; it may be an actual expense, and is always a menace, as it more readily succumbs to adversity. It is desirable in some garden plants which are blanched before use, but must only be induced in these after they have been grown under conditions which have ensured the storage of ample food to supply the etiolated growth.

Even when light is sufficient, foliage formed in a moist atmosphere by plants well supplied with soil

## Warted Foliage

moisture and growing rapidly in a high temperature is thin and papery and readily open to fungus attack. A peculiar effect of these conditions is seen in leaves of vines, tomatoes, and sundry other plants, where some of the cells on the lower surface of the leaves attain an extraordinary size through the amount of water they contain, so that warty growths are formed upon them. These growths not infrequently dry up when the atmosphere becomes dry, and form brown or almost black lumps on the leaves, which are often attributed to fungi or insects. Attention to a proper balance of light, air, heat, and moisture will avoid all these dangers to the health of plants, and it must be manifest that at times the cultivator, in his efforts to obtain greater returns, gambles on the chance of a plant adapting itself sufficiently to adverse conditions to avoid serious damage, and if it does not and he loses, he has only himself to blame.

Shanking of grapes is another trouble connected with the water-supply. At certain times in the life of a plant a greater demand for water has to be met, and can be met only when the roots are in good condition. We have seen that waterlogging of the soil and other conditions may lead to the death of roots, and it is when this has occurred that shanking is most frequent. When the berries have enlarged more water is called for, and if it cannot be had the berries and the stalks that support them shrivel or "shank." An opposite result, the splitting of the

## Splitting of Fruits

berries, occurs when water is more than sufficient, and while it is difficult to regulate the amount the vine shall absorb it is not so difficult to regulate the amount it shall lose. This may be done by (1) maintaining a drier atmosphere to encourage the loss of water, and (2) leaving more leaves on the laterals than is usually done.

Splitting of other fruits, such as tomatoes and apples, occasionally occurs, especially after the plants have been subjected to dry conditions for a time, and then to copious supplies of water. It may be obviated by maintaining uniform conditions, and rendered much less likely by providing available potash. The use of much organic manure often results in splitting, especially in tomatoes, for it makes the soil more moist, and the nitrogen contained encourages "soft" growth.

Bleeding in plants, being the loss of sap from cut ends of stems or from wounds, robs plants of much of the sugar and other foods which they contain. It occurs when roots are active, foliage for getting rid of water vapour either absent or very sparse, and wounds leave an open passage for the flow. Pruning in spring after the rise of the sap is likely to prove detrimental and to weaken plants, and if it must be done the ends of the pruned shoots should be closed by means of "styptic." Removing shoots in summer (unless almost all the foliage is removed) is not followed by bleeding, since the remaining leaves



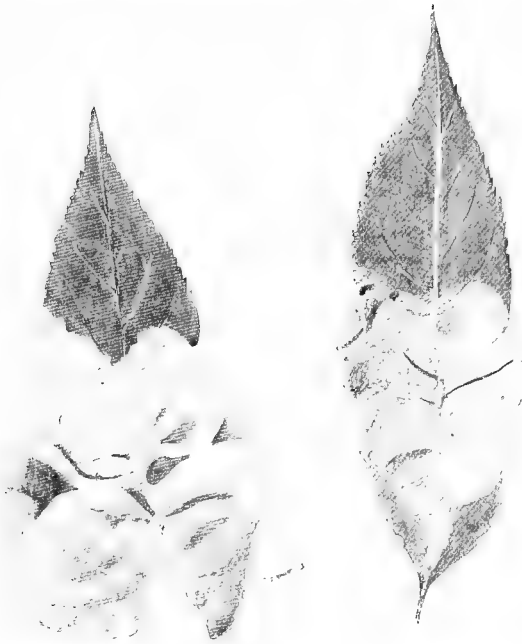

PEACH LEAF-CURL.



APPLE ATTACKED BY BITTER-PIT.

## Bitter-pit

suffice to get rid of the available water without loss of sugar, etc.

Enough has been said to show that some of the chief troubles met with in cultivation are due to improper relations between water available at the root and water vapour given off, and certain mysterious diseases of plants, *e.g.* the bitter-pit of apples and pears, characterised by the presence of brown spots of dead cells in the flesh of the fruit, usually some little way beneath the skin, are probably traceable to the same source. Attention to this important point should be the aim of all who attempt to cultivate plants, and almost all cultural operations, from the preparation of the soil to methods of grafting and budding, have a more or less direct relation to it.

Not only do plants suffer directly through inattention to the maintenance of proper conditions, but the weakened plant is more liable to attack by fungi and bacteria, and even, probably, at times by insects. Every gardener recognises that really good cultivation (*i.e.* the provision of the conditions which secure good health) renders attack by mildew, *e.g.* on peas, far less likely to occur, while protection from cold winds or sudden chills almost certainly secures peaches and the like from the "curl" disease. It might indeed be said that the best preventive of disease is the maintenance of good health.

## Variegation

Brief reference must be made to one or two diseases which are to be regarded at present, possibly because little is actually known about them, as constitutional, unavoidable (unless by rejection of the plants likely to exhibit them), and incurable.

Variegation is to be regarded as a disease, for it is due to absence of green colour from parts of foliage and stems, and this results in a check to food-making and a lessened vigour of growth, but it is often regarded as desirable, and is preserved. It is a transmissible disease also at times, for if, *e.g.*, the variegated greenhouse *Abutilon* be grafted on a green seedling, shoots from below the graft will often be variegated.

The mottling of leaves (without the complete suppression of green colour in the lighter portions) forming the characteristic symptom of the "mosaic" disease as it is called, seen in tobacco, tomatoes, beans, sometimes in *Pelargoniums*, and probably also in figs, is similarly transmissible and, though possibly of bacterial origin, seems possibly constitutional and more or less independent of cultural conditions. It, too, reduces the food-making efficiency of the foliage.

The leaf-curl disease of potatoes is sometimes apparently constitutional. Six diseases of potato are characterised by leaf-curl or leaf-roll, and of these two have not been traced to parasitic origin. One called "curly dwarf" is characterised by shortened internodes, brittle stems, small curled

## Potato Leaf-curl

leaves, and small yield. The other, which is intensified by climatic conditions, is marked by the upward inward rolling of the usually small discoloured leaves, shorter, more erect haulms, small flowers and berries and small yield of tubers which do not decay when planted. In both cases tubers from affected plants produce diseased offspring. Leaf-curl somewhat similar to the first but with less dwarfing is constitutional in certain races of tomato, and occurs in beets, though in the latter it may be of parasitic origin.

The nettle-leaf disease of black currants, in which the foliage is narrower and more divided than is normally the case, and the yield small or none, has not so far been certainly traced to any other than "constitutional" causes. Red currants and gooseberries are sometimes similarly affected.

The doubling of flowers, which is generally a constitutional character, may also be looked upon as a diseased condition, since it generally reduces or destroys the power of the plant to set seed. It is often regarded as an added beauty and preserved in the garden, and is of course in no way detrimental to the well-being of the individual although it is of the race. For some reason not at all clear double-flowered plants are at times more delicate than the corresponding single-flowered type, and the degree of development of the doubling is dependent to a large extent on the available food substances.

## CHAPTER III

### THE NATURE OF FUNGUS ATTACKS

PLANTS find enemies ready to prey upon them both in the vegetable and in the animal kingdom. Among the former fungi and bacteria are the most numerous and important, although a few colourless flowering plants such as dodder, broomrape, and toothwort occasionally find their way into the garden, and prey upon the garden plants. The enemies among the latter are dealt with in later chapters.

The principal characteristics of fungi are : (1) they are not green, *i.e.* they contain none of the green colouring matter possessed by ordinary plants ; (2) their bodies consist usually of slender branching threads called a mycelium, but may be reduced to much smaller proportions, indeed to a minute cell less than a thousandth of an inch in diameter ; (3) they are propagated by minute pieces, called spores, pinched off the mycelium or formed inside special cases.

Bacteria are, broadly speaking, similar to the

## Fungi

fungi, but generally increase by splitting in two at maturity.

The absence of green colouring matter enforces life either as parasites preying upon living plants or animals, or as saprophytes, that is, feeders upon decaying animal or vegetable matter. The latter mode of life, interesting as it is, and important as it is from an economic point of view, does not concern us here, nor do the fungi and bacteria parasitic upon animals. There are many, however, which subsist upon plants and do more or less harm to them.

Each of these parasitic fungi is, as a rule, to which there are several exceptions, restricted to a small range of "hosts," as the plants upon which they prey are called. That is to say, for example, a mildew attacking roses will not also attack peas or gooseberries. The exceptions are generally fungi which attack plants already in ill-health, and some of them are capable of living on decaying matter as well.

The spores are so minute that they are readily carried from place to place by the wind, or on the feet of birds, or by insects, and they are, no doubt, distributed widely by these agencies. Diseased plants themselves may carry them from one garden to another, or from a garden to an exhibition, where some may be left upon a neighbouring exhibit. (How often have we seen "rusted" chrysanthemum

## Spore Distribution

publicly exhibited. It would be a good thing if judges rigidly disqualified such diseased plants.) Refuse and manure heaps may harbour them, or packages which have been in contact with diseased plants may spread the spores. Seed (in the gardener's, less often in the botanist's, sense) may contain them; or the fungus itself, or its spores may adhere to the seeds, and so on. Even particles of soil, as, *e.g.*, from a "club"-stricken cabbage-patch, may spread the fungus to other and hitherto healthy gardens.

Perhaps to follow the history of a familiar fungus is the best way of gaining a clear idea of its way of life. The rose mildew is perhaps as familiar as any, at any rate to country dwellers. The mealy white covering which betokens the attack on shoots and leaves, and later the felted mass of mycelium which encircles the young shoots or forms wide patches upon them, are far too common for the pleasure of the gardener. This felt is so conspicuous because the mycelium is formed wholly outside the plant (the case only in the mildews), merely sending minute suckers into its host to absorb its sap. This robbery results in the shrivelling of the cells attacked in consequence of the loss, and the leaves fail to expand properly, so that food-making is interfered with. Some cells may actually be killed outright, and brown patches result. The mycelium has grown from a spore which germinated where it fell





ROSE LEAF ATTACKED BY BLACK SPOT.



ROSE STEM BADLY CANKERED.

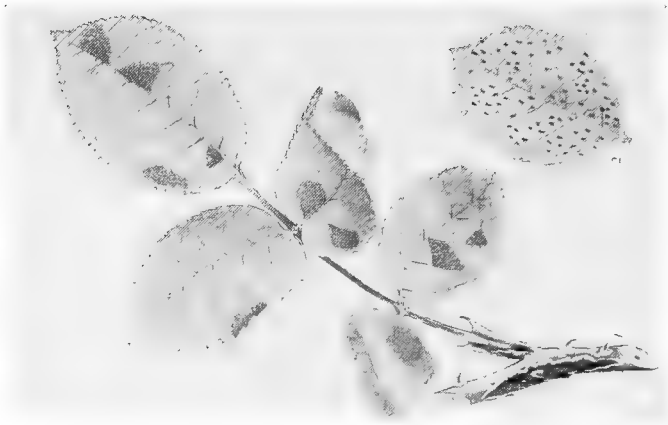

ROSE LEAF AND LEAFLET ATTACKED BY "RUST"  
DISEASE. (See also p. 96.)



ROSE SHOOT AND LEAF ATTACKED BY MILDREW.

## Rose Mildew

upon a leaf or shoot, when moisture, temperature, and air-supply were suitable. It threw out a minute thread from which, if it has reached a leaf which the fungus is capable of attacking, suckers are soon thrust out into the leaf-tissues in search of food.

Feeding on the sap it absorbs, the fungus gradually and quickly spreads all round the spot first attacked and throws up a number of short upright threads from the tips of which spores are pinched off in great numbers. These give the mealy appearance already alluded to. The spores are easily carried to other spots, and if conditions are favourable spread the disease.

These summer spores are produced in great numbers as the parasite grows, but each lives only a short time. Later in the season, when the mycelium has formed a felt, another form of spore is produced inside cases with resistant walls, and these remain over winter, burst in spring, and liberate the spores to renew the disease another season. The felted mycelium may also remain alive and form a centre of infection for another year.

The fungus is the cause of the disease: the host suffers from actual loss of food of which the fungus robs it, and more still from the crippling of the foliage which prevents it from performing its functions of food-making, etc., to the fullest extent. But the host has, under certain circumstances, the

## Disease Resistance

power of resisting the attack. Careful observation will show that

- (1) Old leaves are very rarely attacked.
- (2) Some varieties are almost or quite immune from attack though their neighbours readily fall victims.
- (3) A variety may be attacked in one garden and escape in another.

Possibly the thick cuticle of the older leaves preserves them from penetration by the fungus, but what exactly renders one variety immune and another prone to attack is not yet clear. Certainly the glossy-leaved *Wichuraiana* hybrids are "cleaner" than many hybrid teas, but it is probably not merely a mechanical obstruction that preserves them. Plants in a draught, or which have been subjected to drought, or which are growing in a close, ill-ventilated spot, are usually the first to be attacked. Is it because some substance is formed in them under these conditions which attracts the fungus? or is it because some substance is not produced then which under better conditions prevents the fungus attack? Is it because the fungus spores themselves require to be subjected to a low temperature before they will germinate? or is it a combination of any or all of these?

It is a remarkable, and probably significant thing, that in the moist warm districts of the tropics mildews are unknown, as they are, so far as I know,

## Peach Curl

in stoves in this country. It is certain, too, that conditions which keep roses growing without a check render attacks of mildew less likely.

A remarkable instance of the dependence of fungus attack upon external conditions, unfavourable to the host but favourable to the parasite, is afforded by the leaf-curl disease of the peach, practically unknown when the plants are grown under glass or in sheltered situations, frequent and disastrous in plants exposed to cold winds and other retarding influences. Damping-off in seedlings, again, one might be tempted, but for the manner in which the trouble spreads, to attribute solely to close seeding and close, damp conditions, yet a fungus is always involved too.

We have thus more than one cause contributing to the development of the disease—the fungus itself, the constitution of the host-plant, and the nature of the environment which influences either the host or the fungus or both.

The mycelium of the parasite is usually not external as it is in the mildews. It generally burrows about inside its host in its search for food, creeping between the cells and sending suckers into them, or passing through them. It may produce a poison which actually kills the cells it comes in contact with (even some little distance ahead of the mycelium), or grow without doing more harm than arises from robbing the plant of some of its sap and diverting

## Disease Symptoms

to its own ends what was intended for the nourishment of its host. Curiously contorted growths are often produced through the check to the development of local parts induced by the parasite, or through a curious effect such as is seen in cabbage roots attacked by the club-root organism, where much more extensive growths than usual are induced. These dead spots, contortions, and swellings afford symptoms by which diseases may be recognised, and will be referred to again.

When the mycelium of the parasite is internal, as a rule a number of threads are thrust out of the host to form spores for the distribution of the fungus, or fruits containing the spores are produced on the surface of the host. The spore-bearing threads or fruits are usually massed in sufficient numbers, and have some characteristic colour, which enables a gardener, with the aid of a pocket-lens such as all good gardeners carry, to use them for the recognition of a disease.

To make out the structure of the spores themselves, and to identify the fungus with certainty, requires the aid of a compound microscope and considerable training, and are usually impossible for the gardener. These things are necessary to the proper understanding of the disease, but many common attacks may be recognised readily without this kind of examination.

Some fungus attacks are confined wholly or

## Sclerotia

almost wholly to the parts of the plant below ground, such, for example, as wart disease of potatoes, club-root of cabbages, and the like, and may become evident only when the plant is lifted. On the other hand, destruction or damage to the absorbing roots may occur and wilting of foliage follow. The spores of the fungi concerned are present in the soil about infected plants, and are carried from place to place not only on or in infected plants, but with the soil itself. Little imagination is required to picture the trouble likely to arise from conveying such soil on plants during transplanting, on tools, boots, carts, and the like, from infected to clean situations ; the wind-borne dust may carry the spores too.

Certain fungi form masses of mycelium which rest through ungenial seasons. Pieces as large as peas or larger, generally black, occur inside the stem of Dahlias or potatoes when attacked by the "Sclerotium disease." They are black outside and solid, rather like wax to cut, and will withstand drying and other conditions unsuitable for growth. Such masses are called sclerotia, and the term "Sclerotium disease" is derived from their name. "Fire" in tulips is due to one of them. Curious sclerotia are formed by the fungus which attacks the roots of anemones and sends up brown cups in spring where one looked for a brilliant display of blossom. The whole root is permeated by the fungus, and the sclerotium assumes the form of the root which the

## Fungi in Winter

fungus has killed. "Mummy" apples and plums are produced when these fruits are attacked by the fungi which cause "brown rot," the whole flesh being filled by the mycelium, and they form resting sclerotia. The ordinary mycelium itself may cease to grow but still remain alive for some time as in mushroom spawn such as is sold for making mushroom beds. Myriads of spores are produced by the mushroom on the gills of the edible fruit, but gardeners have to depend upon the white thread-like mycelium of the fungus for purposes of propagation. We have many instances of this "perennial mycelium" among fungi causing plant diseases. The rust of mint, the smuts of Scillas and of Carnations, are examples. Once attacked these plants are affected year after year and annually produce a crop of spores. In these cases their utility or beauty are injured but their existence not materially threatened. It is otherwise with the perennial mycelium of certain fungi which attack trees, such as *Stereum purpureum*, which produces silver-leaf, or *Nectria ditissima*, which is associated with "canker" of fruit trees.

No means of reaching the mycelium of a fungus inside a plant are known. Nothing at present known which can be injected or made to pass into a plant will kill the fungus without at the same time damaging the plant itself. In the treatment of plant-diseases induced by fungus attack the most



## Forefall Disease

important thing to attend to is, therefore, the prevention of attack. Not only is "prevention better than cure"; it is often the only way to avoid death.

Diseases due to fungi and bacteria are generally characterised by the formation of spots of various colours on the affected parts of the plant, these spots being either masses of spores or fungus fruits, or groups of dead or damaged cells; or by locally increased growth; or by the destruction of parts of the plants; in all cases accompanied by the causal organism, either immediately or in the near neighbourhood. The attack is dependent upon

- (1) The presence of the fungus or its spores;
- (2) The plant being of a variety liable and in a condition suitable to attack;
- (3) The conditions of moisture, air, and warmth, etc., being suitable for the germination of the spores and the growth of the fungus.

The attack starts in one or a few places and progresses more or less rapidly according to the nature and condition of the plant and its surroundings. The disease is very "catching," and not only the diseased plant but its immediate surroundings are likely to be a source of infection to others if the disease is allowed to continue long.

The sudden death of a plant without previous symptoms of ill-health is not likely to point to fungus attack as a cause. Fungus attacks may appear to be

## Disease Symptoms

sudden as, for instance, in the case of the too well-known potato-blight, where a whole field will seem to be smitten and dead within a few days. It is true the fungus spreads rapidly and works quickly when the conditions which induce the development of thunderstorms prevail, but it has been growing on the lower leaves of the plants earlier, and has not been noticed because it has been hidden.

Perhaps a word of caution in interpreting symptoms should be given. When a fungus is found growing on a dead leaf or a dead spot on the leaf, it is not a certain sign that the fungus is the cause of the death of the leaf or of the part of it. The proof of the fungus being the cause is not a very easy matter to establish. The spores of the fungus in question must be obtained free from all mixture with other spores, or indeed with other organisms; they must germinate upon and attack an otherwise healthy plant kept from chance infection by any other organism of any kind whatever; this attack must produce the same symptoms as were present in the original attack; and finally the fungus must fruit and prove its identity with that which was used to infect.

Only when the fruits and spores of a fungus are obtained can its identity be established.

We have already alluded to the fact that not all the varieties of any one kind of plant are equally

## Immunity

open to infection by a parasite which attacks one variety of it. For example, the spores of a certain mildew which attacks grasses will not attack a grass "A" if they have been taken from mildew on a grass "C," although spores from mildew on grass "A" will readily attack the leaves of other plants of the same variety. They will, however, attack grass "B," and spores produced by the mildew growing on grass "B" from the spores obtained from grass "C" will attack grass "A." This fact seems to show that one and the same fungus may behave differently according to the source from which it is obtained, and it has been found possible to train a fungus which usually lives on dead plants to attack living ones! Further, one stage of a fungus may grow on a living plant, and another slightly different stage, only on the dead remains of the plant. A fungus may enter a plant (generally through a wound) and grow but fail to fruit until the plant it has attacked is dead—such are the fungi that produce silver leaf in plums and "coral-spot" on the dead shoots of currants.

A further remarkable phenomenon shared with certain animal parasites is afforded by some of the rust fungi. These fungi form a distinct group and in their most highly developed forms produce a variety of different spores during their life-history. The early stage when present produces numerous dust-like spores in minute circular cups with turned-

## Alternate Hosts

back edges on the surface of living leaves. These spores germinate, and later on produce spores of a totally different kind, and frequently will not attack the same kind of plant as that upon which they were produced. Thus the spores produced by the fungus *Coleosporium Senecionis* on the needles of the Scots fir, germinate and attack, not that, but the groundsel or the Cineraria and produce totally different symptoms; *Cronartium ribicolum* grows in its cup stage on *Pinus Strobus*, but forms its later spores on the black currant; *Puccinia Pringsheimiana* has its early cup stage on the gooseberry, its later on the sedge; *Puccinia Pruni* lives first on the anemones, later on the plum; and so on. The latest spores formed on these second hosts usually rest, and after their rest produce the cup-forming stage on the first-mentioned host only, but an intermediate form generally occurs produced on the second host which attacks that host only. The best-known instance is probably the red rust of wheat. In spring the fungus, *Puccinia graminis*, forms whitish cups (aecidia) on the leaves of Barberry. The yellowish spores (aecidiospores) attack the wheat, and the mycelium in summer forms reddish groups of spores (uredospores) in small patches on the wheat leaves. The uredospores germinate immediately and attack other areas on the wheat leaves, so spreading the infection. Towards autumn the mycelium which has hitherto produced uredospores forms another

## Rusts

kind of spore altogether, of a deep chestnut colour and of different form (teleutospores), incapable of immediate germination. The teleutospores remain on the dead straw through the winter and then germinate, forming there a few spores only which cannot attack wheat but grow only on the Barberry, recommencing the life-cycle.

These and other phenomena make the study of diseases of plants produced by fungi very interesting, but at the same time very difficult, and complicate methods of control. For instance, the destruction of all the black currants within a radius of two miles of a plantation of *Pinus Strobus* would doubtless protect that valuable tree from the blister-rust that has proved so fatal to it where it has occurred, but so many interests would be involved that such measures are almost impracticable.

## CHAPTER IV

### TREATMENT OF FUNGUS ATTACKS

METHODS of dealing with fungus attacks fall mainly into three groups according to the end they have in view. Either they aim at

- (a) The protection of the plant against attack ; or
- (b) Rendering conditions unsuitable for the growth and spread of the fungus ; or
- (c) The removal of the source of infection.

We have already dealt with the principal safeguard against disease in our first chapter, and need only briefly mention the necessity for the maintenance of proper cultural conditions and of adequate and properly balanced supplies of earth-salts, water, air, light, and heat. We may put the remaining methods in numbered paragraphs to facilitate reference, but this important recommendation applies to all. In addition we have :

1. The selection of varieties resistant to or immune from attack. This is possible in comparatively few cases at present, but research will show

## Pruning

that such varieties already exist, or are attainable in many more.

2. Removal of dead foliage, dead shoots, and dead plants from the neighbourhood of living ones. These dead parts often harbour pests or permit an entrance into the living parts by way of the dead. The wood-pile and the rubbish heap should not be near the garden.

3. Pruning away the diseased parts completely as soon as seen, and immediate destruction of them by burning.

4. Complete removal and immediate destruction of diseased plants and of the soil about them by burning. By no means let them reach the rubbish heap. Even feeding pigs with diseased parts is apt to be dangerous.

Weeds such as groundsel, sowthistle, shepherd's purse, charlock, chickweed, briars, and the wild parents of our cultivated trees often harbour fungus pests, and should be watched and promptly dealt with.

5. Pruning and otherwise wounding plants in cultural operations in such a way that the wounds readily heal over. Protection of all wounds by painting them over with lead paint, Stockholm or gas tar, or a  $2\frac{1}{2}$  per cent solution of lysol. This painting does not assist healing but forms a barrier to the entrance of fungi and bacteria.

6. Steeping seed and tubers suspected or known

## Spraying

to be infected with fungus diseases or with fungus spores, with the object of killing them. The principal substances used are hot water, copper sulphate, formalin, and hydrogen peroxide. The hot water and copper sulphate methods are used almost entirely in treating farm seeds, and we need not consider them further. Formalin is used in treating both seeds and tubers, hydrogen peroxide in treating seeds.

(a) *Formalin Treatment.*—A solution of 1 part of formalin (=40 per cent solution of formaldehyde) is made in 200-300 parts of water. The seeds or tubers are steeped in this solution for two hours.

(b) *Hydrogen Peroxide Treatment.*—The seed is steeped to two hours in the full strength hydrogen peroxide (20 vols.) and rinsed in clean water. The half strength (10 vols.) may be used. It is usually convenient to dry the seed before sowing.

7. Dusting or spraying plants with a poisonous substance so that spores, falling on the plant and commencing to germinate, will come in contact with it and perish. Sulphur and copper compounds are generally most effective. The former are used against mildews, as they tend to destroy the external mycelium which these fungi form.

*All sprays, whether dust or liquid, should be applied in a state of very minute subdivision, and when the sun is not bright; an endeavour should be made to cover all parts of the plant completely.*



## Sprays

(a) *Sulphur-dusting*.—Flowers of sulphur are dusted over the affected parts, or those it is desired to protect, by means of powder bellows specially constructed for the purpose, or of a flour-dredger.

(b) *Sulphur-fumigation*.—Sulphur is placed in a specially constructed vessel and heated so as to be vaporised, *but not burned*; the vapour is condensed on the foliage, etc., and every part becomes covered with a thin film of sulphur. A crude method of effecting this has been in vogue, the sulphur being heated on a hot iron plate, but there is great danger of it bursting into flame, and *the gas formed by burning sulphur is fatal to living plants*.

Another method of applying sulphur is that of making a paste of it in milk and painting the hot-water pipes. The heat of the pipes probably causes the sulphur to be very slowly oxidised and the poisonous gas to be produced in sufficient quantities to check fungi effectively.

(c) *Liver of Sulphur*, or potassium sulphide.—Liver of sulphur is dissolved in water at the rate of 1 oz. to 3 gallons (or 1 oz. to 4 gallons, when tender plants have to be sprayed). The solid material should be kept from the air or it speedily deteriorates, and care should be taken to obtain only the soluble forms. It is a useful fungicide, but stains white-lead paint black.

(d) *Copper Compounds*.—Liquids containing copper are used, for the most part, for spraying

## Fungicides

plants open to attack by fungi which live inside the plant, and enter through the pores in the leaves. They are used for the purposes (1) of killing the fruiting threads of the fungi as they emerge into the air to form spores, and (2) of preventing the germination of spores which fall upon the leaf.

Care must be used in spraying with them when parts of plants which are eaten are to be dealt with ; *e.g.* spraying broad beans attacked by rust with a copper fungicide would be perfectly safe, as only the shelled immature seeds are to be eaten, but spraying dwarf beans when the pods are formed will be inadvisable.

Three mixtures containing copper are used for the summer spraying of foliage, and one for winter spraying of dormant trees only. They are respectively Bordeaux mixture, soda -Bordeaux or Burgundy mixture, ammoniacal copper carbonate, and copper sulphate solution.

Great care must be exercised in preparing these fungicides (which are better made at home), but if the following directions are followed there need be no difficulty.

*Bordeaux Mixture.*—Put 6 lbs. copper sulphate (of 98 per cent purity) (called also blue stone or blue vitriol), broken small or powdered, into a loosely woven canvas bag and hang it the night before the fungicide is to be used in a *wooden* tub containing about 20 gallons of water. [An iron or galvanized

## Fungicides

vessel must not be used.] Into another vessel put 4 lbs. of good quicklime (unslaked lime) and slake it by adding water, gradually at first until the lime crumbles, then more quickly so as to form a milk. Next morning, *when the milk of lime is cold* [both liquids *must* be cold], strain it through a coarse cloth so as to remove all lumps, into the copper sulphate solution, stirring well meanwhile. When nearly all the milk of lime is used allow the mixture to settle a little, then test the clear liquid from the top by adding a drop to a drop of potassium ferrocyanide on a white plate. If no red colour is produced the mixture is fit for use, but if a red colour is formed, more milk of lime must be added until the clear liquid gives no red colour with potassium ferrocyanide. When no red colour is produced by this test, it shows that all the copper is combined and the risk of burning the foliage is reduced to a minimum. The mixture should be of a blue colour if properly prepared, and the fine powder to which the colour is due should be slow in settling out. Make up to 40 gallons with water, and make afresh whenever it is wanted.

This is the most generally useful and most tried fungicide, and is in wide use in all civilised countries.

*Soda-Bordeaux or Burgundy Mixture.*—Dissolve 10 lbs. of copper sulphate in 25 gallons of water in the way recommended above. Dissolve  $11\frac{1}{2}$  lbs. of washing soda in another 25 gallons. When both

## Rotation

are *cold* mix thoroughly just before using. To test this mixture use litmus-paper. If red litmus is turned blue by it, add more copper sulphate; if blue litmus is turned red, add more soda solution. It should have no effect upon litmus-paper.

This is rather easier to make, and seems to be almost as effective as Bordeaux mixture when used for the same purposes, although it has not yet been used to any great extent in this country.

*Ammoniacal Copper Carbonate.*—Make 5 oz. of copper carbonate into a paste with a little water, add strong ammonia (·880) until the copper carbonate is just dissolved so as to form a deep blue solution (about 3 pints will be required); dilute this to 45 gallons with water. The stock solution may be kept in a tightly stoppered bottle. This may be used where Bordeaux mixture is likely to cause defoliation, as with peaches against shot-hole.

*Copper Sulphate Solution.*—One pound of copper sulphate (98 per cent) is dissolved in 25 gallons of water in a wooden vessel.

This solution must be used only in winter, while the trees are dormant.

(e) *Potassium permanganate* diluted to a rose-red colour is useful against some rust fungi such as rose rust, hollyhock rust, carnation and Saxifrage rust.

8. Rotation of crops and breaking up areas occupied by one kind of crop. Modern methods of

## Insects and Disease

growing one kind of crop over large areas have made the spread of plant pests much more easy than it formerly was, and something in the way of breaking up these areas by interposing other crops will impose a check to their spread. In the same way changing the ground occupied by one crop in succeeding years will render the attack of pests which lurk in the soil more difficult.

9. Destruction of "hosts" of garden enemies. In paragraph 4 above we advocated the destruction of diseased weeds and the like, but it is as important to remove this chance of propagating disease-producing fungi. Where possible the alternate host of the rust fungi (where there is one) should be destroyed. Hedge plants should differ from the cultivated crops as much as possible.

10. The fruits of the large fungi which attack timber and ornamental trees should be removed as soon as they appear, so as to prevent the formation and spread of the spores.

11. Certain insects, such as woolly aphis, are concerned in the spread of certain plant diseases and should be destroyed.

12. An acid condition of the soil encourages the growth of certain fungi such as club-root, and should be remedied by the application of quicklime at the rate of 3-4 tons to the acre ( $\frac{3}{4}$ -1 bushel to the square rod) spread over and forked in. It is, however, better to avoid the need for this drastic dressing by

## Legislation

smaller dressings calculated to avoid its necessity (see Chapter II.).

An opposite state of affairs encourages a few bacterial diseases such as iris rhizome rot, and here the admixture of superphosphate of lime at the rate of  $1\frac{1}{2}$ -2 oz. to the square yard will be beneficial.

13. Of recent years legislation has been aimed at the control of certain plant diseases, but while of some value when carefully considered and efficiently and intelligently administered, too much must not be hoped from it. Legal enactments regarding plant diseases are apt to leave too many loopholes through which the fungus may escape and spread for any great dependence to be placed upon it. Nothing short of cessation of all commerce and intercommunication is likely to stop the wide-spreading of disease, and even that would fail to stop its spread over narrower areas. Loyal observance of the enactments, together with personal observation, intelligent cultivation, and prompt application of remedial measures, are all requisite.

14. We close this chapter with a reiteration of the advice to maintain good health by attention to hygienic requirements, *i.e.* good treatment. Avoid damp, close quarters; avoid draughts; avoid acidity of soil; avoid over-manuring.

## CHAPTER V

### SYMPTOMS OF FUNGUS ATTACKS

#### ACER PSEUDOPLATANUS (Sycamore).

*Foliage.*—Black blotches on leaf-tissue caused by *Rhytisma*. Collect and burn fallen leaves (2).<sup>1</sup>

#### ALMOND.

*Stem.*—Gummy excretion arising from crack in bark of trunk or branches. Cut out and burn affected parts, painting wounds (5).

*Foliage.*—Swollen, red, and blistered-looking leaves, caused by attack of *Exoascus deformans* = Peach Curl disease. Keep free from draughts. Remove as soon as seen (3); spray with Bordeaux or Burgundy mixture in February (7).

Roundish holes in foliage with a brown edge; or brown spots which subsequently drop out, caused by *Cercospora circumscissa*. Spray foliage and soil with Bordeaux or Burgundy mixture (7).

<sup>1</sup> Figures in thick type refer to a paragraph in Chapter IV. where the remedial measure is described.

## Symptoms

### ANEMONE.

*Rhizome*.—Large hard, blackish masses of mycelium replacing rhizomes, white within and waxy to cut; producing brown cup-shaped fruits in spring. *Sclerotinia tuberosa*. Dig up and burn when fruits are seen.

*Foliage*.—Cluster cups (species of *Aecidium*, often forms of *Puccinia*), forming spots on stalk and blade. Affected plants are often taller than normal.

### ANTIRRHINUM.

*Stem and Foliage*.—Pale brown or almost white roundish or elliptical spots with minute black dots upon them. *Septoria antirrhini*. Spray with potassium sulphide or Bordeaux mixture (7).

### APPLE.

*Root*.—Large globular swellings about the size of a golf ball (larger or smaller), generally with a corrugated surface. Crown gall, due to *Bacillus tumefaciens*. Not a serious disease in this country. Cut off and burn affected roots when planting.

*Stem*.—Areas eaten out, as it were, down to the wood, the edges of the wound showing attempts to heal which have failed; in winter having the round bright red fruits of the fungus upon the dead healing tissue, in spring the brownish mounds of fungus mycelium. Canker,





YOUNG APPLE SHOOTS ATTACKED BY AMERICAN BLIGHT.



APPLE SHOOTS ATTACKED BY CANKER.

## Symptoms

due to *Nectria ditissima*. Cut out cankered spots and paint wounds (5); attend well to drainage and destroy woolly aphis (p. 122). Other fungi produce canker; treat in same way.

Young branches cracked, and with olive-green areas upon them. Scab (see fruit, below).

Young branches cracked, twigs and spurs dying, and bearing small grey mounds of fungus mycelium and spores. Brown rot (see fruit, below).

*Foliage*. — Dark branching mycelium on leaves, followed by dead spots. Scab (see fruit, below).

Rounded brown spots with a dark margin and bearing minute black dots on upper surface. Leaf-spot. *Cladosporium herbarum*. Attend to health of tree; spray with Bordeaux mixture (7). *Sphaeropsis malorum* also forms similar spots (and cankers on stem), and is treated similarly.

The whole leaf covered with a white powdery mildew which also involves the shoot. The mycelium subsequently forms a felted mat on the shoot, which becomes very weak and often dies. Conspicuous, owing to grey colour in winter. Prune off and burn as soon as seen, below the point of attack (3). Some varieties are much more prone to attack than others, e.g. "Bismarck," "Lord Grosvenor," "Irish Peach." Caused by *Podosphaera leucotricha*.

## Symptoms

*Flower.*—Pistil turns black as though affected by frost, and a gummy exudation occurs about base of styles. A bacterial disease for which no cure is known ; probably carried by insects.

Whole flower turns brown and dies ; flower stalk generally shrivels and is covered by a microscopic grey mould. Brown rot, see fruit below. (Must not be confused with attack of Apple Psylla, which produces somewhat similar symptoms, but the flat green or yellowish insect may be found in that attack embedded in a gummy secretion ; nor with Apple-blossom weevil (p. 125).)

*Fruit.*—Dark green roundish spots on surface of fruit (at first covered by the white cuticle which the fungus lifts up and ruptures), which finally become scurfy and surrounded by an olive-green ring. In hard-fleshed apples like "Cox's Orange Pippin," when the attack is early, flesh of fruit often cracks badly as well. Both shoot and leaf are attacked. Scab caused by *Fusicladium dendriticum* (the final stage of this fungus is called *Venturia inaequalis* and occurs on fallen leaves). Prune out affected shoots in winter (3), burn affected apples, spray in winter with copper sulphate solution (7) and just before buds burst and again after petals have dropped, and also, if necessary, about the end of June with Bordeaux mixture (7).



*Stereum purpureum* ON STEM OF APPLE.  
This is the fungus that causes silver-leaf disease.



APPLE ATTACKED BY SCAB DISEASE  
(*Fusicladium dendriticum*).

## Symptoms

The fruit begins to decay prematurely, and small grey heaps of fungus spores arranged in "fairy rings" occur on the decaying spot. Attack generally begins at a wound made by an insect. The apple finally becomes a "mummy," and remains hanging on the tree through winter. The shoots and flowers are also attacked. Brown rot caused by *Sclerotinia fructigena* (*Monilia fructigena*). Destroy affected fruit by fire; prune and spray as for "scab."

Small brown circular spots on fruit at first minute, gradually but slowly enlarging; at first only skin deep. Probably caused by a fungus; no remedial measure known.

### ARABIS.

White shining swollen convex patches on the leaves as though sprinkled with whitewash brush. White rust caused by *Cystopus candidus*.

Powdery greyish-white patches, on pale finally dead brown spots. Rot mould caused by *Peronospora parasitica*.

Spraying is hardly called for with this plant, but affected foliage should be removed and burned to destroy the resting spores of these two disfiguring fungi.

### ASTER (MICHAELMAS DAISY).

*Foliage*.—The whole plant covered with

## Symptoms

powdery white mildew; leaves more or less striated. Mildew caused by *Erysiphe cichoracearum*. Spraying with liver of sulphur (7).

### AZALEA INDICA.

*Buds and Foliage.*—Terminal bud or leaves near tip of stem become swollen to many times their normal size, pink, and subsequently covered with a white bloom. Remove the galls, which are caused by the fungus *Exobasidium japonicum*, and burn before the white bloom (the spores) is developed (3).

A similar fungus forms galls on *Rhododendron ferrugineum* and other species (p. 95).

### BEAN, BROAD.

*Foliage.* — Reddish-brown spots, showing heaps of chestnut spores upon them under the lens, on foliage. Rust caused by *Uromyces Fabae*. Not as a rule serious early enough to warrant spraying, but Bordeaux mixture or potassium permanganate (7) may be used if it is thought necessary. Burn rusted stems instead of putting them on rubbish heap.

### BEAN, DWARF AND RUNNER.

*Foliage and Fruit.* — Reddish round or roundish depressed spots on fruit, brown rounded spots on foliage and stems; in all cases distinctly margined. Spot disease due to *Colletotrichum Lindemuthianum*. Spray with



## Symptoms

Bordeaux mixture (7). Burn affected fruits. The seed from diseased fruits is apt to contain the fungus.

### BEET.

*Foliage.*—Small reddish-brown spots, on which heaps of chestnut spores are to be seen with a lens, scattered over the leaf surface. Rust due to *Uromyces Betae*. Most prevalent when soil is deficient in potash. Rarely worth spraying for.

### BERBERIS.

*Foliage.*—The yellow cups of one stage of the rust of wheat, *Puccinia graminis*, occurs on spots on the under surface of the leaves of some species of *Berberis*. On the upper surface of the leaf minute yellowish “pycnidia” occur.

BORECOLE. See Cabbage.

BROCCOLI. See Cabbage.

BRUSSELS SPROUTS. See Cabbage.

BULLACE. See Plum.

### CABBAGE.

*Seedlings.*—The stem becomes thin and dies at about ground level, and the seedling topples over. More prevalent under glass than in the open. Thin seeding and early transplanting. Soil sterilisation. Caused by *Pythium De Baryanum*. A minute fungus called *Oplidium Brassicae* also attacks young

## Symptoms

cabbages in damp, ill-drained places. Brown spots are evident on the lower part of the stem, which dies and decays.

*Root.*—Rootlets swollen in a spindle shape much larger than normal; whole plant often sickly-looking; root subsequently rots and sets free spores of the fungus, *Plasmodiophora Brassicae*, to infect succeeding crops of same family. Keep down weeds belonging to cabbage family (9); practise rotation of crops (8); lime the soil thoroughly (12). This is club-root and should be distinguished from cabbage gall weevil, which produces little lumps on the stems, each containing a small grub.

*Stem.*—One-sided heads, or failure to form heads, together with a dark ring seen in the stem when cut across; leaves, except veins, yellow (at margins at first); veins brown or black. Slugs and caterpillars spread the cause of this disease, a bacterium, *Pseudomonas campestris*. Practise rotation (8); remove affected leaves and destroy affected plants by fire (3, 4). Seed should not be saved from infected plants. [Black rot.]

*Foliage.*—White rust and rot mould; see Arabis. Destroy affected parts (3, 4); spray (young plants only) with Bordeaux mixture or liver of sulphur (7); keep down weeds (9).



'WISLEY' TRAP FOR THE TURNIP FLEA BEETLE.

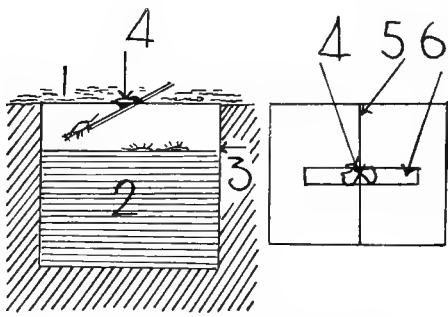

A SIMPLE MOUSE-TRAP FOR USE IN THE GARDEN.

1. Shows the tin buried in the soil. 2. The water in the tin. 3. At the point shown by the arrow a hole is made in the side of the tin to prevent the latter becoming full of water. 4. Show a lump of grease fastened to the tilt on the cross wire. 5. The cross wire. 6. The tilt fastened to the latter, with small wire on the top of the tin. A hole must be punched in the tin, or it will become full of water.



CLUB ROOT ON BRUSSELS SPROUTS.

## Symptoms

Pale green, later dry whitish or brown spots caused by *Mycosphaerella brassicicola*. Same measures as for white rust.

### CALCEOLARIA.

Sudden wilting of plant. Cause doubtful, but of fungus origin, probably a species of *Phytophthora* which enters from the soil. Remove and destroy affected plants (4); practise rotation (8); sterilise soil in which plant is propagated; lime soil.

### CALLISTEPHUS HORTENSIS (CHINA ASTER).

Sudden wilting of plant due to *Phytophthora*. Measures as with Calceolaria wilt.

### CAMELLIA.

*Foliage*.—Rounded or irregular blotches, silvery white, with a distinct margin. Blotch with minute black dots. *Pestalozzia Guepini*. Remove and burn diseased leaves; sponge with Bordeaux mixture.

### CARNATION.

*Stem*.—Yellow spot on deformed side of stem, due to *Fusarium* sp. (? *dianthi*). Destroy portions affected (3); practise rotation (8); sterilise soil.

*Foliage*.—Rusty heaps of spores; when these fall, leaving light yellow spots. Rust. *Uromyces caryophyllinus*. Maintain dry atmosphere; destroy affected parts (3); spray with Bordeaux mixture or liver of sulphur (7). Roundish

## Symptoms

bright brown, then whitish spots (also on stem), with dark fungus tufts arranged in concentric circles. In bad cases most of leaf involved. Black-mould or fairy-ring disease due to *Heterosporium echinulatum*. Treatment as for rust. Select resistant varieties.

Spots yellowish, later with a rose or dull violet margin; brownish-black dots upon the spot. Leaf-spot due to *Septoria Dianthi*. Treatment as for rust.

Grey or white powdery covering over foliage. Mildew. *Oidium* sp. Sprinkle with flowers of sulphur, and maintain a dry atmosphere while giving sufficient water in soil.

*Flower*.—Masses of violet-brown dust replacing pollen, so that centre of flower is smutty. *Ustilago violacea*. Smut. Plant is infected while very young and is perennially affected. Destroy (4).

CAULIFLOWER. See Cabbage.

CELERIAC. See Celery.

CELERY.

*Foliage*.—Dark dull green to brown or yellowish-brown spots on foliage, densely covered with black dots. Leaf-spot due to *Septoria Petroselini* var. *Apii*. Destroy affected parts by fire (3, 4); spray from May onwards with Bordeaux mixture (7); use seed free from infection (sterilise by hydrogen peroxide (6)).



CELERY FLY.

1. Celery fly. 2. Grub. 3. Chrysalis.

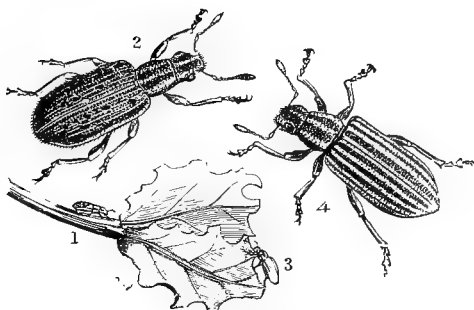

PEA AND BEAN WEEVILS.

1 and 2. *Sitones crinitus*, natural size and magnified.  
 3 and 4. *Sitones lineatus*, natural size and magnified.



WINTER MOTHS.  
Male and two females.

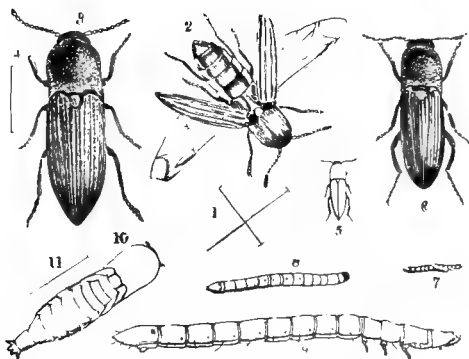

CLICK BEETLES AND WIREWORMS.

1 and 2. *Agriotes lineatus*. 3 and 4. *A. obscurus*. 5 and 6. *A. sputator*. 7 and 8. Show wire-worms natural size. 9. Wire-worm magnified, 10 and 11. Chrysalis.



## Symptoms

### CHERRY.

*Root.*—Large globular swellings on root = Crown gall; see Apple.

*Stem.*—Gummy exudations through wounds in stem or bark of twigs. Remove and burn diseased branches, painting over all large wounds.

*Foliage.*—Small round brown spots which fall out, leaving a hole with a brown margin. Shot-hole due to *Cercospora circumscissa*. Spray with Bordeaux mixture (including soil surface).

Leaves wither, but remain hanging dead on tree through winter. Collect and burn dead foliage. Spray with Bordeaux mixture (7).

Leaves silvery or ashen. Silver leaf, see Plum.

*Flower.*—Withering and browning of flowers prematurely, and rotting of young fruits due to *Monilia fructigena*. See treatment for Apple brown-rot.

### CHIONODOXA.

*Flower.*—Brownish-violet masses of spores in place of pollen. Smut, due to *Ustilago Vaillantii*. Plants are attacked in the seedling stage and never recover. Destroy them (4). The same fungus attacks *Scilla*.

### CHRYSANTHEMUM.

*Foliage.*—Greyish-white growth on leaves and flower buds, the younger leaves being deformed. Mildew due to *Oidium chrysan-*

## Symptoms

*themii*. Dust with flowers of sulphur or spray with liver of sulphur (7). Spots appearing brown on upper side of the leaf, and bearing on lower side groups of chocolate-brown spores. Rust. *Puccinia chrysanthemi*. Select resistant varieties (1); propagate only from healthy stock; spray with liver of sulphur as a preventive (7).

Dark brown rounded spots with a distinct margin, on upper side of leaves, showing minute black dots. Leaf-spot due to *Septoria chrysanthemi*. Burn affected parts (3); spray with Bordeaux mixture or liver of sulphur (7).

### CINERARIA.

*Foliage*.—Greyish-white growth on leaves. Mildew, due to *Oidium* sp. Dust with sulphur or spray with liver of sulphur (7).

Bright orange-yellow waxy patches on under side of leaf, rarely visible above. Rust due to *Coleosporium Senecionis*. Keep away from related weeds such as groundsel and ragwort. The alternate host is the Scots Pine.

### CLEMATIS.

*Stem*.—Sudden wilting and dying of part or whole of shoot. Due to the fungus *Ascochyta clematidina*. Remove all dead or dying foliage and shoots and spray with Bordeaux mixture if spotted foliage be seen.

*Foliage*.—Greyish-white growth on leaves and flowers. Mildew, due to *Oidium* sp. Dust

## Symptoms

with flowers of sulphur or spray with liver of sulphur (7).

### CRATAEGUS.

*Foliage.*—Leaves (and sometimes fruits) swollen and bearing orange spots upon which tufts of cup-like growths, at first flask-shaped, later cylindrical, containing yellow spores, occur. Rust due to *Gymnosporangium clavariiforme*, which has Juniper as alternate host.

Greyish-white growth on leaves and shoots, which are somewhat dwarfed. Mildew due to *Podosphaera Oxyacanthae*.

Yellow spots on upper surface of leaves, due to *Pleospora Oxyacanthae*. These are not sufficiently serious to call for remedy.

### CRESS.

*Stem.*—The lower part of stem at ground-level dies and the seedlings topple over. Thin seeding, ventilation and soil sterilisation are the best preventive measures. Caused by *Pythium De Baryanum*.

### CUCUMBER.

*Stem.*—The lower part becomes “cankered” and the upper part wilts. *Mycosphaerella citrullina*. Destroy plants and avoid use of soil again for cucumbers or melons.

*Foliage.*—Whitish growths on leaf surface. Mildew due to *Erysiphe cichoracearum*. Dust with flowers of sulphur (7).

## Symptoms

Small round dirty-white margined spots, or larger grey spots in leaves. Leaf-spot, due to *Cercospora Melonis*. Ventilate houses so as to get "hard" foliage; spray with liver of sulphur or Bordeaux mixture (7).

*Fruit*.—Dark depressed spots on rind of fruit, later becoming black and cracking, and sometimes with gummy exudation; frequently large. Flesh of fruit below spot golden or tawny. Scab, due to *Cladosporium Scabies*.

Circular brown dry spots on rind. Due to *Gloeosporium orbiculare*.

A bacterial disease sometimes causes rot of fruit (and of foliage). The bacteria are easily carried by insects.

Spraying is rarely effective with these diseases. Clean cultivation, destruction of affected parts, and good ventilation are the best preventives.

### CURRENT.

*Stem*.—Shoots die back and bear bright coral-red fruits of the fungus *Nectria cinnabarina* upon them. The fungus enters through dead wood; prune out all such.

### DAHLIA.

*Stem*.—Death of lower part of stem, which bears a grey mould, and subsequently develops resting bodies of fungus mycelium as large as peas or larger, often within the stem. Sclero-

## Symptoms

tium disease caused by *Sclerotinia Sclerotiorum*, for which there is no cure: burn affected plants.

DAMSON. See Plum.

DELPHINIUM.

*Foliage*.—Whitish growth on leaves, which may become somewhat deformed. Mildew due to *Erysiphe polygoni*. Dust with flowers of sulphur or spray with liver of sulphur (7). Many weeds are attacked by this fungus.

DIANTHUS. See Carnation and Sweet William.

ERICA.

*Foliage*.—Leaves and terminal part of shoot covered with whitish powdery growth. Mildew due to *Oidium* sp. Dust with flowers of sulphur.

FIG.

*Stem*.—Cracks in bark and wood which fail to heal, gradually girdling stem, which is finally killed. Canker due to *Libertella ulcerata*. Cut canker spots completely out, and paint these and other wounds. Disinfect knife.

*Fruit*.—Velvety grey patches at apex of fruit, the tissues rotting and being reduced to a pulpy mass. Grey-mould due to *Botrytis cinerea*. Burn infected fruit.

Bitter rot due to *Gloeosporium fructigenum* sometimes attacks figs; treatment, see Apple brown rot.

A "mosaic" disease of the foliage in which

## Symptoms

light yellowish patches appear in the leaves is probably of bacterial origin but awaits investigation.

### GOOSEBERRY.

*Stem.*—Shoots die, the foliage withering; tufts of grey fungus spores appear on dead or dying parts. Die back due to *Botrytis* sp. Prune out. Keep bushes in healthy growth by manuring.

*Stem, Foliage, and Fruit.*—Greyish white powdery mildew on stem, foliage, and fruit, later turning dark brown, and bearing minute deep brown globular fruits; forming a brown felt on stem generally near tip. Growth stunted. American Gooseberry mildew—*Sphaerotheca Mors-uvae*. Cut off all tips of shoots of affected plantation in early autumn, and burn them. Pick and burn affected berries. Spray with liver of sulphur (half summer strength for tender varieties).

*Foliage.*—Greyish powdery growth on leaves, which are usually only slightly affected, generally not attacking stems or fruit. Not forming a felt nor becoming dark brown. European Gooseberry mildew—*Microsphaera Grossulariae*. Spray with soda-Bordeaux mixture (7).

Yellow spots on one side of leaf, yellow-bordered red spot on other, bearing longish cups with white fringed margin filled with

## Symptoms

orange spores. Gooseberry rust — *Puccinia Pringsheimiana*, having as its alternate host sedges which should be kept down in neighbourhood of gooseberries.

GRAPE. See Vine.

HAWTHORN. See Crataegus.

HELLEBORUS.

*Foliage.*—Dark blotches somewhat rounded in form, marked with indistinct rings. Leaf-blotch due to *Coniothyrium concentricum*. Pick off diseased leaves and spray remainder with liver of sulphur (7).

HOLLYHOCK.

*Foliage.*—Slightly discoloured spots on upper surface, small, at first red-brown, later darker, raised spots below. Rust due to *Puccinia malvacearum*. No alternate host. Raise fresh stock every year. Destroy seedlings found attacked (the disease is apt to be conveyed in the seed), and spray with potassium permanganate.

HYACINTH.

*Foliage and Bulb.*—Veins of leaves and bulb yellow, due to presence of a yellow bacterium, *Bacterium Hyacinthi*. Burn affected bulbs.

IRIS.

*Rhizome.*—The rhizome and lower part of leaves become soft and rot away, the foliage brown. Due to a bacterium which is encouraged by lime in the soil. Treat soil with super-

## Symptoms

phosphate of lime after removing decaying portions. Most prevalent when plants have been subject to frost, or other severe check.

*Foliage.*—Large or small dark spots with a yellowish or brown border, the dark portions being velvety with the spores of the fungus *Heterosporium gracile*. Remove all dead and dying leaves thoroughly in autumn, and treat the soil surface liberally with slaked lime.

*Bulb.*—Black crust-like patches on outer bulb scales of *Iris reticulata* and its allies formed by the fungus *Mystrosporium adustum*. Soak bulbs in formalin (6). Plant such bulbs apart from healthy ones.

## JUNIPER.

*Stem.*—Long woody swellings with fissured bark through which the fungus emerges in soft orange club-shaped masses, often forked and variously curved. Juniper-rust due to *Gymnosporangium clavariiforme* and *G. juniperinum*. The former has for its alternate host the leaves and fruits of *Crataegus* (*q.v.*); the latter the Mountain Ash. The galls may be cut out and burned.

KOHL-RABI. See Cabbage.

## LARCH.

*Stem.*—Wounds in the stem which exude resin, and which fail to heal in spite of repeated attempts. Larch canker due to the attack of



## Symptoms

*Peziza Willkommii*. Plant larch in suitable positions, well drained and not subject to spring frosts. Avoid planting very large breadths of larch only. Some species of *Larix*, e.g. *L. leptolepis*, are more resistant than the common larch, *L. europaea*.

LATHYRUS. See Sweet Pea.

LAUREL.

*Foliage and Young Shoot*.—Greyish-white mould on the foliage, especially young foliage. Mildew due to *Sphaerotheca pannosa*. Dust plants with flowers of sulphur or spray with liver of sulphur (7).

LAVATERA TRIMESTRIS.

*Stem and Foliage*.—Yellowish-brown rounded spots on leaves, long spots on stems with a darker margin. Due to *Colletotrichum malvacearum*. Destroy affected plants as soon as seen, and spray remainder with Bordeaux mixture or liver of sulphur (7). The disease is liable to be carried in the seed. The same fungus attacks and kills hollyhocks in America.

LETTUCE.

Drop disease. The whole plant withers. Attacked by fungus (*Botrytis* sp.) at base of stem. Measures, see below.

*Foliage*.—Yellowish spots on foliage, with white velvety fungus upon them on under side. Leaf subsequently rots. Rot mould due to

## Symptoms

*Bremia Lactucae*. Allow ample space ; remove completely and burn affected plants and all old leaves from beds, etc. Sowthistle and some other weeds are also liable to attack by this fungus.

### LILY.

*Foliage and Stem*.—Brown spots on leaves and buds which, with the stem, subsequently die and dry up, while the flowers are distorted. Due to *Botrytis cinerea*. Lime (mortar rubble or chalk) should be mixed with the soil for those lilies that do not dislike lime, especially in the upper three or four inches, and the plants grown in airy places not exposed to strong cold draughts or late frosts. Dusting the bulbs with sulphur is reported to have been beneficial.

### LYCHNIS.

*Foliage*.—Yellow blotches on foliage bearing groups of chestnut spores often in concentric rings. Rust due to *Puccinia lychnidearum*. Not usually serious enough to spray for.

*Flower*.—Pollen replaced by purplish-violet fungus spores which escape and discolour the middle of the flower. Smut due to *Ustilago violacea*. Destroy the plant, as the fungus is perennial from the seedling stage.

### MALVA.

Various species are attacked by Hollyhock rust. See Hollyhock.

## Symptoms

### MELON.

*Stem.*—Canker, see Cucumber.

*Foliage.*—Leaf-spot due to *Cercospora Melonis* and a bacterial disease (which also affects the fruit). See Cucumber.

### MIGNONETTE.

*Foliage.*—Dusky brown indeterminate patches on leaves, under lens appearing velvety. Due to *Cercospora Resedae*. Most common in damp soil lacking lime. Spray with Bordeaux mixture or liver of sulphur (7).

### MINT.

*Foliage.*—Leaves become yellowish and sickly-looking, and bear on lower side (and often on rhizomes, too), cup-shaped receptacles containing spores in spring, followed in summer by small patches of chestnut-brown spores. Rust due to *Puccinia Menthae*. Perennial in tissues, therefore destroy affected plant completely. Spray remainder with potassium permanganate.

MULLEIN. See Verbascum.

### MUSTARD.

*Stem.*—Damping off. See Cress.

### NARCISSUS.

*Foliage.*—Dies prematurely near tip. Leaf spot due to *Ramularia Vallisumbrae*. Destroy diseased tissue. If occurring in second season spray with Bordeaux mixture (7).

## Symptoms

NECTARINE. See Peach.

NYMPHÆA.

*Foliage.*—Holes with decaying tissues around them. *Ramularia nymphæarum*. Remove diseased leaves, and maintain stream of slowly running water.

OAK.

*Stem.*—Several bracket-like fungus fruits appear on stems of oak, when the fungi themselves are growing in and causing the decay of the wood. These fruits should be cut away and burned as soon as seen.

*Foliage.*—Leaves and young shoots covered with powdery white fungus growth. Mildew due to *Oidium* sp. No remedy can be effectively applied.

ONION.

*Foliage.*—Greyish-lilac tufts on foliage, sometimes entirely covering it. Onion mould, *Pero-  
nospora Schleideni*. Sow onions in autumn; avoid damp sites; spray with Bordeaux mixture (7); destroy all dead foliage by fire (resting spores are found in diseased leaves).

*Bulb.*—Minute black hard bodies about the neck of the bulb, the tissues of which are softened and decay gradually spreads, due to *Mucor subtilissimus*. Avoid using nitrate of soda or other manure tending to sappy growth; dry off bulbs before storing.

## Symptoms

### PEONY.

*Foliage.*—Leaves become spotted with brown or turn wholly brown, or base of stalk becomes brown and leaf flags; spots covered with grey fungus, due to *Botrytis Paeoniae*. Small black, hard, resting bodies about size of mustard seed form on lower part of stalk or in soil. Remove all diseased foliage; spray with Bordeaux mixture or soda-Bordeaux (7).

### PALMS.

*Foliage.*—Black spots are frequently developed on foliage of palms of various kinds due to fungi (more than one species being involved). The destruction of dead leaves and the removal of affected parts are the best modes of treatment.

PANSY. See Viola.

PARSLEY (see also Parsnip).

*Foliage.*—Small brown spots on foliage on which minute black dots occur, due to *Septoria Petroselini*, possibly identical with the fungus which attacks celery (*q.v.*). Not generally troublesome; but if it should prove so, spray with liver of sulphur (7).

### PARSNIP.

*Foliage.*—White mouldy patches on under side of leaf, which turns brown in patches. Due to *Plasmopara nivea*. The fungus also attacks the root and forms rusty patches upon it. If outbreak spreads, spraying with Bordeaux

## Symptoms

mixture may be resorted to (7). Burn diseased tissues, which may contain resting spores.

PEA (Culinary).

*Root.*—Chestnut brown patches on root which subsequently dies, foliage turns yellow, and buds drop or shrivel up. Due to *Thielavia basicola*. See that drainage is thoroughly efficient. Manure with potash manures.

*Stem.*—Brown stripes or streaks in stem, brown (at first water-soaked) spots in leaves. Bacterial disease encouraged by hot conditions and spread by diseased seeds. No cure known. Diseased seeds have water-soaked (when young) or brown areas in the cotyledons.

Lower part of stem shows brownish ring when cut, foliage wilts and turns yellow, due to a species of *Fusarium* (*F. vasinfectum*?). Avoid planting on same ground next season. Burn diseased plants.

*Foliage.*—Whitish powdery patches on foliage due to mildew, *Erysiphe polygoni*. Most abundant on late peas. See that soil is moist, and avoid hot, dry places; sow late peas in trenches.

Yellow spots on foliage, later followed by greyish tufts of a fungus, due to *Botrytis cinerea*. Most common in wet places.

*Pods.*—Round yellowish spots with a brown margin, sometimes also on leaves. The centre of the spot is occupied by brown fungus fruits.

## Symptoms

Due to *Ascochyta Pisi*. Spray with Bordeaux mixture or soda-Bordeaux.

### PEACH AND NECTARINE.

Gumming, leaf-curl, and shot-hole, see Almond. Silver-leaf, see Plum.

*Foliage*.—Small yellowish spots on upper surface, chestnut-brown heaps of spores below freely scattered over leaf. Rust due to *Puccinia Pruni*. Spray with Bordeaux mixture.

*Fruit*.—Whitish depressed spots on mature fruit, surrounded by a blackened margin, due to *Gloeosporium fructigenum*. Spray with liver of sulphur or Bordeaux mixture. Burn affected fruit.

Small round, at first greenish, then brownish or olive spots on ripe fruit; the spots finally run together and form a brown crust; the fruit cracks and decays. Scab due to *Cladosporium carpophilum*. Spray before ripening of fruit with Bordeaux mixture.

Greyish powdery growth over leaf and fruit, often affecting considerable area of fruit surface. Mildew. Dust with flowers of sulphur or spray with liver of sulphur.

*N.B.*—Ammoniacal copper carbonate may be used in all cases where Bordeaux mixture is recommended for spraying peaches or nectarines with less likelihood of damage to foliage. See No. 7 (p. 62).

## Symptoms

### PEAR.

*Foliage.*—Leaves distorted with blisters, hollow below, the interior of the hollow being whitish. Due to *Exoascus bullatus* (not to be confused with pear-leaf blister mite (p. 114)). Spray with Bordeaux mixture (7).

*Fruit.*—See Apple. Scab in the case of the pear is due to *Venturia pirina* (= *Fusicladium pirinum*). Treatment as for apple scab.

[*Note.*—Foliage, especially of soft shoots, turns suddenly brown, although hitherto in apparently vigorous health; black sticky fluid exudes from bark. Fire-blight, an American disease, for which watch should be kept, due to *Bacillus amylovorus*. Carried by insects. Burn all infected shoots and disinfect knife used in pruning, before and after each cut.]

### PELARGONIUM.

*Stem* becomes blackened and decays; leaves turn yellow; pale spots, sometimes flesh-coloured, appear on blackened portion of stem. Stem-rot described by Dr. Cooke as due to *Fusarium Pelargonii*. Destroy plants.

[Grey mould (*Botrytis cinerea*) often appears on dying foliage and shoots of Pelargoniums. A drier atmosphere and less close conditions should be maintained, and all decaying leaves, etc., burned.]





A TENT OF LACKEY MOTH CATERpillARS.  
These do considerable damage to Apple and Plum Trees.



PEARS CRACKING DUE TO PEAR SCAB FUNGUS.

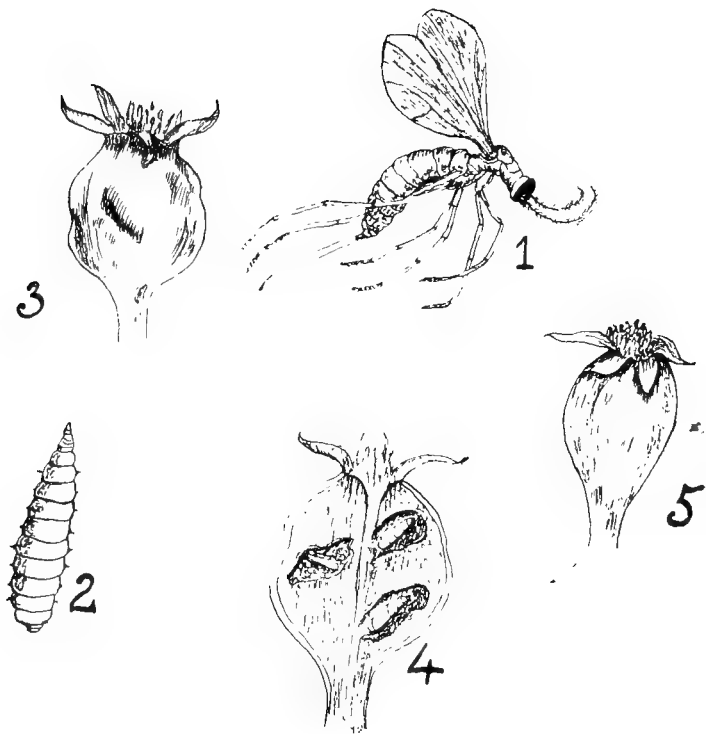

THE PEAR MIDGE AT VARIOUS STAGES.

1. Fully-developed fly.      2. Grub taken from a fruit.      3. Deformed fruit.  
 4. Grubs inside the fruit.      5. A perfect fruit.

## Symptoms

**PERIWINKLE.** See *Vinca*.

**PHASEOLUS.** See *Bean*, *Dwarf*, and *Runner*.

**PINE.**

*Foliage and Shoots.*—White cups, torn at the mouth, filled with orange spores scattered on foliage, those on young shoots larger, crowded and with torn, spreading mouth. Blister rust due to *Coleosporium Senecionis*, having its alternate host on groundsel and on *Cineraria* (*q.v.*).

A somewhat similar rust on *Pinus Strobus* (Weymouth Pine) (and attacking also other pines with their needles in groups of fives) has as its alternate host the black currant. It has proved very destructive to the Weymouth Pine, and where attempts are made to grow this species the black currant should be exterminated. Due to *Cronartium ribicolum*.

**PLUM.**

*Root.*—Crown gall. See *Apple*.

*Stem.*—Shoots bear small black fruits of the fungus embedded in the bark; later they die. The wood is discoloured. Cut out and burn all dead and dying shoots and branches. Due to *Cytospora* sp. Also attacks cherries and other kinds of fruit trees.

*Foliage.*—Leaf becomes pallid and shiny as though varnished. Upper skin easily separates from leaf-tissues below it. Branch

## Symptoms

fails to fruit and finally dies. Wood becomes discoloured, starting at a wound. Silver-leaf, due to *Stereum purpureum*, which fruits only on the wood which it has killed. Cut out and burn all affected branches below the point at which the wood is discoloured. Keep all dead wood out of trees. Paint over all wounds (p. 57). *The fungus enters only by wounds.* Attacks various trees, especially "stone fruits."

Under side of leaf sprinkled with chestnut brown heaps of spores, darker in the later stages; whole leaf yellowish. Rust due to *Puccinia Pruni*, which has as alternate host *Anemone coronaria* (see Anemone). Remove anemones from neighbourhood of plums. Spray with Bordeaux mixture in June and July (7).

*Fruit.*—Young fruits grow very rapidly, globose at first, but becoming elongated and curved, up to two inches long by end of June; yellowish or reddish at first but becoming grey, then black, finally falling. Probably spraying with Bordeaux mixture (7) as soon as petals fall would check the disease, which is called "pocket plums" and is due to *Exoascus Pruni*.

For brown rot see Apple. The attack on the stem is more frequent than in the apple, and particular attention should be paid to pruning out the branches and spurs which show the

## Symptoms

greyish-brown hard resting bodies of the fungus through cracks in the bark, especially in spring.

**POLYANTHUS.** See Primrose.

**POPLAR.**

Various spot-forming fungi occur on poplar leaves, e.g. *Septoria Populi* (small round whitish spots with greyish margin edged with brown), *Marssonia Populi*.

Two rusts, *Melampsora aecidioides* and *M. populina*, occur on poplar leaves, the former forming yellowish groups of spores closely scattered over the lower surface, the latter brown ones or later blackish ones covered by a crust, also on the lower surface.

Blisters on leaves, convex above, concave and golden yellow below, attacking also catkins of poplar and aspen. Due to *Taphrina aurea*.

**POTATO.**

*Tuber.*—Brown discoloration just beneath skin. Blight. *Phytophthora infestans*, see foliage.

Oval or round scurfy spots on skin. Brown scab due to bacterium, *Actinomyces chromogenus*. Steep seed tubers in formalin, 1 part to 200 water, for 2 hrs. before sprouting.

Deep scabs, dark green at first, generally most numerous near "nose" end. Canker due to *Spongospora subterranea*. Avoid planting on same soil in next season.

## Symptoms

Wart-like outgrowths, white, green or blackish. Wart disease due to *Synchytrium endobioticum*. Plant only immune varieties. Notify Ministry of Agriculture.

Decay in store, brown depressed patches with patches of white fungus thereon. Winter rot, due to *Fusarium Solani*. Ventilate clamp thoroughly.

*Never plant diseased tubers.*

*Stem.*—Wilts and turns black at base, especially in vascular bundles. *Bacillus solanacearum*. Do not use tubers for seed. Remove plant completely.

*Foliage.*—Black spots rapidly extending in damp summer weather. Grey below. Blight due to *Phytophthora infestans*. Spray before outbreak with Bordeaux or Burgundy mixture (7).

### PRIMROSE.

Foliage with yellowish patches on upper and under side, bearing tufts of fungus threads, due to *Ramularia Primulae*. Spray with Bordeaux mixture.

### PRIMULA.

Few fungi attack species of *Primula* in this country, but *P. megaseaefolia* is often attacked by a fungus which produces brown spots on the leaves. Spray with potassium sulphide or Bordeaux mixture.



POTATOES ATTACKED BY WART DISEASE.



ROSE LEAF DAMAGED BY THIRPS.  
The whitish markings on the leaves are caused by  
these pests.

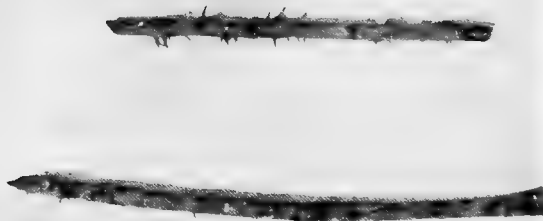

ORANGE RUST FUNGUS ON STEM OF BREA.  
(See also p. 45.)



### RADISH.

Subject to same fungus attacks as Cabbage (p. 71).

### RASPBERRY.

*Stem.*—Pallid patches on bark bearing minute black fungus fruits, due to *Ascochyta* sp., etc. Remove diseased canes. Spray in August with Bordeaux mixture.

*Foliage.*—Small yellow spots thickly sprinkled over lower surface, followed by tufts of dark spores, due to the rust fungus *Phragmidium Rubi-Idaei*. More common on wild than on cultivated plants. Cut out old canes as soon as they have fruited, and keep stools free of dead leaves and rubbish.

### RHODODENDRON.

*Foliage.*—Swellings the size of a pea to that of a marble, at first yellowish-green, later rosy with a whitish bloom. Due to *Exobasidium Rhododendri*, and occurring on *Rhododendron ferrugineum*, *R. hirsutum*, and *R. Wilsoni*. Pick off and burn the galls.

### ROSE.

*Root.*—Large globular swelling due to the Crown-gall organism *Bacterium tumefaciens*. Cut away and burn.

*Stem.*—Cracks in bark through which corrugated tissue-growths protrude, on which small black fungus fruits develop. The spots at first

## Symptoms

show a purplish discoloration of the bark about a wound. Canker due to *Coniothyrium Fuckelianum*. Cut out and burn affected stems. Spray plants with Bordeaux mixture (7), and paint over all wounds (5).

Dead areas appear around buds or on long strong shoots due to *Botrytis cinerea* attack (see Gooseberry).

Bright orange patches of spores appear on the stem in spring—rust, see below.

*Foliage*.—Dusty white patches on leaves and near tips of young growths. Foliage is crumpled and fails to expand. White felted patches on stems in winter. Mildew, due to *Sphaerotheca pannosa*. Dust plants with flowers of sulphur, or spray with liver of sulphur (7). Prune away all trace of the fungus in spring (3).

Black roundish blotches on upper surface of leaves, with branching threads radiating from them. Leaves fall after turning yellow prematurely. Destroy fallen foliage (2). Spray from May onwards with Bordeaux mixture (7). Yellow spots closely scattered over lower surface of leaves, followed by brown and black spots. Foliage sometimes falls early. Rust due to *Phragmidium subcorticium*. Collect and burn fallen leaves. Spray with potassium permanganate (7).

Irregular pale brown spots extending rapidly

## Symptoms

over leaf and bearing threads of greyish fungus on lower surface. Leaf withers and drops, and whole plant dies. Most frequent under glass. Destroy all fallen foliage (2) and spray at first onset of disease with Bordeaux mixture (7). Rot due to *Peronospora sparsa*.

### SALSIFY.

*Foliage*.—White spots scattered over whole of leaf surface, due to *Cystopus Tragopogonis*. Destroy affected plants and spray remainder with Bordeaux mixture or liver of sulphur (7).

### SAXIFRAGE.

*Foliage*.—Chestnut-brown spots scattered over leaf-surface, the leaf becoming yellow or brown eventually. Attacking *Saxifraga longifolia* and other allied species. Rust due to *Puccinia*. Dip foliage in a rose-red solution of potassium permanganate or spray with it (7).

### SCILLA.

*Foliage*.—Scattered brown spots. Rust due to *Uromyces Scillarum*. Remove foliage and spray healthy plants with Bordeaux mixture.

*Flower*.—Smut due to *Ustilago Vaillantii*. See Chionodoxa.

### SEAKALE.

*Root*.—Black specks in section of root, followed by rot due to a bacterial attack.

Swellings on root, similar to those produced by *Plasmodiophora Brassicae* on cabbage

## Symptoms

(*q.v.*). In both diseases destroy plants, and plant next year on another site.

### SEMPERVIVUM.

*Foliage.*—Covered with yellowish-brown spots. Rust due to *Endophyllum Sempervivi*. No cure known; burn.

### SENECIO PULCHER.

*Foliage.*—Rust, see *Cineraria*.

### SNOWDROP.

*Whole plant* covered with grey mould and rotting. Due to *Botrytis Galanthina*. Remove bodily and burn, taking care to distribute the spores as little as possible.

### SPINACH.

*Foliage.*—Rounded or irregular pale yellow spots, dotted after a while with tufts of black fungus threads, the fruits of *Heterosporium variabile*. Spray with liver of sulphur (7).

Greyish dense velvety patches covering considerable areas on the foliage, which finally dies and becomes rotten. Burn affected parts so that they do not harbour the resting spores of the fungus, *Peronospora effusa*. Spraying with liver of sulphur may check the spread of the fungus (7).

### STOCK.

*Seedlings.*—Damping off, see *Cress*.

### STRAWBERRY.

*Foliage.*—Brown or reddish circular spots,



TRANSVERSE SECTION OF DISEASED DAFFODIL BULB SHOWING DISCOLOURED AND DEAD FLESHY SCALE  
LEAVES DUE TO EELWORM INFECTION.



1



2



3



4



5



6



7

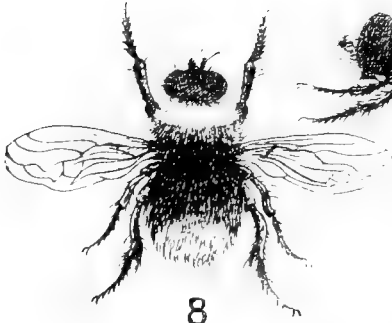

8



9



10

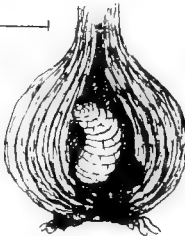

11



12

THE DAFFODIL FLY IN VARIOUS STAGES.

## Symptoms

later with a dead-white centre, bearing numerous spores which germinate at once, and later in autumn others which mature only in spring, due to *Sphaerella Fragariae*. In autumn cut off all foliage, allow to dry somewhat, then burn (assist if necessary with a little paraffin).

Leaves curl and become covered with powdery white growth, often spreading to the fruit. Mildew due to *Sphaerotheca Humuli*. Spray with liver of sulphur or dust with flowers of sulphur at the first onset of the attack. Most prevalent in draughty places.

*Fruit*.—Often attacked by *Botrytis cinerea* when in damp, ill-ventilated spots, causing fruit to rot, and to bear a felt of greyish fungus fruits.

### SWEET PEA.

Same diseases and treatment as Culinary Pea (*q.v.*).

### TOMATO.

*Root*.—Killed by *Phytophthora cryptogaea*. Plant wilts. Treatment, see Calceolaria.

*Stem*.—Brown stripes on stem. Stripe disease due to *Bacillus* sp.? Cut out diseased stems and burn.

*Foliage*.—Yellow spots, felted beneath, due to *Cladosporium fulvum*. Ventilate freely. Spray with Bordeaux mixture (7).

Black spots. Blight. See Potato.

## Symptoms

### TULIP.

*Foliage and Flower Stem.*—Yellow or brownish spots scattered over the foliage, which may be malformed and crumpled in consequence. Flowers also spotted and, if weather be damp, quickly rotting, and covered with grey mould. Black resting bodies among scale leaves at neck of bulb or in soil. “Fire” or tulip disease due to *Botrytis parasitica*. Remove badly diseased plants and destroy. Collect and burn diseased foliage. Do not plant in infected beds, and protect from cold winds and spring frosts.

TURNIP. Club-root. See Cabbage.

### VERBASCUM.

*Foliage.*—White powdery growth on surface of leaves. Mildew due to *Oidium* sp. Dust with flowers of sulphur.

### VINCA.

*Foliage.*—Dark chestnut heaped-up spots on surface of leaves, which are usually narrowed and yellower than normal. Rust due to *Puccinia Vincae*. Dig up and destroy affected plants, as fungus is perennial in the tissues.

### VINE.

*Foliage.*—Puckered and covered with whitish powder, subsequently spotted. Fruit whitish, afterwards marked with darker spots. Mildew, due to *Oidium Tuckeri*. Apply flowers of sul-



## Symptoms

phur (7). Attend to ventilation and avoid draughts.

*Fruit*.—Brown spots later bearing grey mould. *Botrytis cinerea*. Keep air in slight motion so as to avoid drops of water on the berries. Remove any cracked fruits.

Brown spot with a definite outline, covered with tiny raised fruits. Anthracnose due to *Gloeosporium rufomaculans*. Burn affected berries and spray rods with Bordeaux mixture just before vine starts in spring.

### VIOLA.

*Stem and Leaves*.—Yellow spots bearing at first cup-shaped receptacles full of fungus spores, later brown spores of rust fungus *Puccinia Violae*. Destroy diseased plants. Spray remainder with potassium permanganate (7).

### WALLFLOWER.

*Root*.—Club-root. See Cabbage.

*Foliage and Stem*.—Upper part of shoot and frequently whole seedling covered with greyish-white mould, the fruiting threads of *Peronospora parasitica*. Destroy affected plants and spray seedlings with Bordeaux mixture (7). White rust (see Cabbage) sometimes attacks wallflowers.

## CHAPTER VI

### ANIMAL PESTS OF THE GARDEN

THE animal pests of plants, unlike the fungi, which for the most part restrict themselves to one or a few hosts, are frequently somewhat general in their attacks. This statement must not be taken to apply too widely or it may be misleading. For example, certain scale insects and aphides, and even caterpillars and their kin, have a very limited range of food-plants, but it is true to the extent that some groups of pests are better dealt with all together than by repeating their names, etc., time after time under their host plants. Again, several divisions of the animal kingdom include pests of cultivated plants, whereas, besides fungi, few pests occur in other branches of the vegetable kingdom. It is not surprising to find this is so, since all animals depend directly or indirectly upon plants for food.

Of the larger animals—the animals that in colloquial language are “animals”—with warm blood and a covering of hair, the weasel, stoat,

## Mice, Rabbits

shrews, bats, and one or two others which are carnivorous, are to be regarded as friends of the garden, while mice, rats, rabbits and hares, and sometimes the squirrel, are distinctly harmful. Of all the "mice," perhaps the short-tailed field mouse is the worst, but other mice and voles commit serious depredations at times, especially among bulbs and seeds, either fresh-sown or left to ripen. The efforts made to destroy owls and kestrels often lead to an inordinate increase in these troublesome creatures, which will often gnaw the bark of trees in hard weather and expose the wood below to drying up. Trapping (the brick trap or figure-of-four trap or a break-back trap are best) is the only means open to the gardener, though sometimes the strewing of chopped-up furze about choice plants will protect them, and of all baits probably a small piece of fat bacon or a piece of tallow are the most effective.

Where rabbits or hares are troublesome, trapping again must be resorted to, but the protection of the garden by a wire fence with at least nine inches below ground, put up before anything is planted, and the whole ground thoroughly scoured to destroy rabbits and hares, is the wisest course. For some reason the choicest apples in a plantation are nearly always the ones to suffer attack upon their bark by these gnawing animals, Cox's Orange Pippin, for instance, coming in for marked attention, while others around are neglected. If trees are barked in this way it is

## Moles, Birds

well to cover the wounded part with a plaster of clay and cow dung to prevent the drying out of the wood and to encourage the bark to grow and cover the wound as quickly as possible.

The mole is an insect feeder, and if it were not for its habit of tunnelling and of making unsightly mounds would be regarded as a friend, but when it burrows along under a row of newly germinated beans and throws its unsightly casts up on what should be a smooth lawn, this too cannot but be regarded as a pest in the garden and must be trapped accordingly.

We have said nothing of the use of poison placed where the animals are likely to pick it up, for animals so killed may be eaten by others which would likewise suffer, but the use of virus for killing rats is not open to this objection, and is a valuable aid for ridding a garden of these pests for a time, but the treatment needs repetition at intervals.

Comparatively few birds do any great damage in the garden, and even some of the most troublesome do some good at times. Exception must perhaps be made of the jay [whose depredations among peas (aided by the hawfinch) are scarcely counterbalanced by the beauty of its plumage] and of the cheerful piping bullfinch. We may check his liking for buds, and hinder the tits from damaging them too, by a timely application of a lime-sulphur or lime-spray, and bushes may be protected by lacing black

## Seed Protection

thread here and there about them or by protecting them within a fine-meshed wire cage. Black thread stretched two or three inches above the rows of peas and other seeds forms as efficient a protection against birds as the wire cages made for the purpose, and sparrows may be hindered by the same means from destroying crocuses in town gardens. Netting must also be resorted to to protect fruit from black-birds and thrushes where they are protected, and from starlings, birds far too valuable to destroy. Seeds such as peas and beans are best protected from mice and birds by damping them with water and then sprinkling red lead over them. Linnets and chaffinches are often troublesome where seed is being saved, and may also need to be excluded by means of nets or pieces of curtain tied over the seeding plants. Rooks rarely come actually into the garden, but walnuts may suffer from their powerful beaks, and possibly jackdaws also may help to destroy them. Waterfowl and water plants rarely both succeed in the same habitat, and sparrows especially are a nuisance in town gardens, where they use the leaves of water lilies (which suffer severely from their sharp claws) as platforms from which to drink.

Fish are extremely useful in the ornamental water. Not only do they keep down the plant-eating insects, but many, like the roach and carp, feed upon the troublesome flannel weed.

## CHAPTER VII

### THE NATURE OF INSECT ATTACKS

THE greater part of the damage done to garden plants is the work of insects, and few plants are immune from their attacks.

The number of different species of insects is immense, and the diversity of their food is only exceeded by the diversity of their forms. Different as they are in size and appearance, however, they have certain characteristics in common, viz. the body and its appendages jointed ; the body separable into three distinct parts, head, thorax, and abdomen ; six legs (and in addition in caterpillars, etc., some sucker feet) ; in the mature state two or four wings (rarely none) ; breathe through holes in the sides of the body, not through the mouth ; have " feelers " or antennæ attached to the head (these are organs of touch and hearing, and probably also of scent) ; and usually progress from egg to perfect insect through a remarkable series of changes easily seen in the history of the moth, where the egg hatches

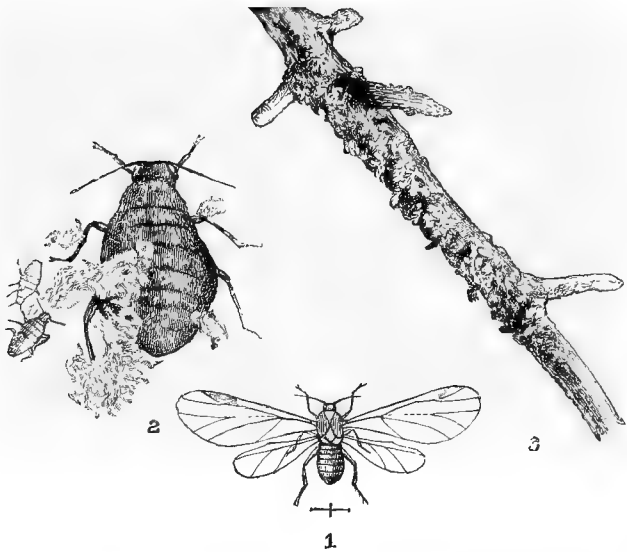

AMERICAN BLIGHT IN VARIOUS STAGES. —|— SIGNIFIES NATURAL SIZE.

1. The Fly. 2. The Insect. 3. Showing its effect upon a fruit-tree shoot.

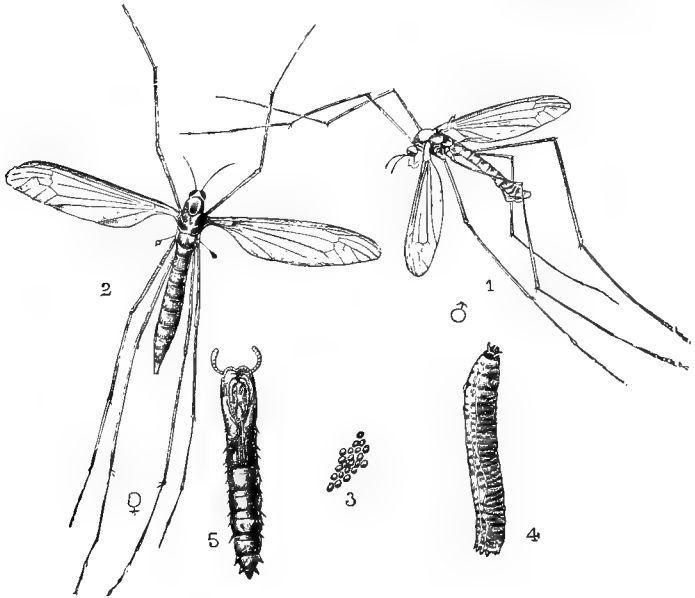

DADDY-LONG-LEGS OR CRANE FLY.

1. Male Daddy-long-legs. 2. Female Daddy-long-legs. 3. Eggs. 4. Grub. 5. Chrysalis.

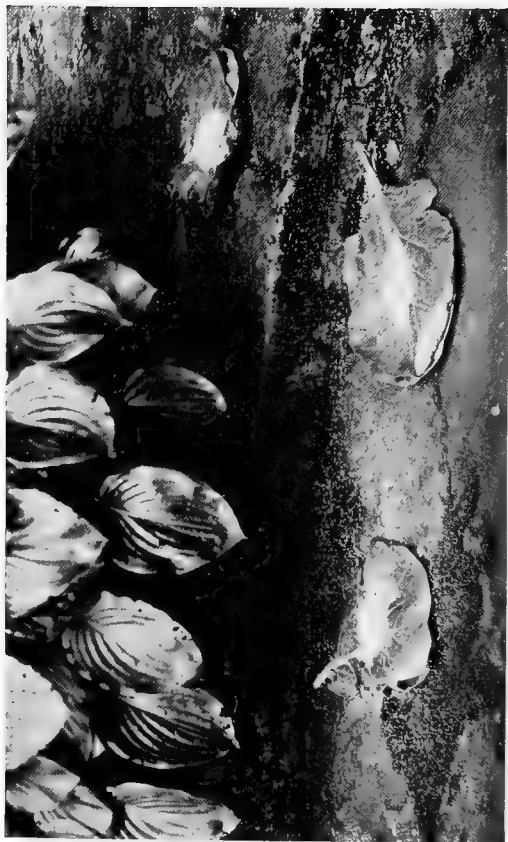

AN OLD DEVICE FOR TRAPPING SLUGS.



## Insect Characteristics

out into a caterpillar which feeds by biting leaves, moults half-a-dozen times or so, finally becoming a chrysalis without legs or wings, almost quiescent, and doing no feeding, which in its turn becomes a moth which crawls out of the chrysalis case, dries its wings, feeds by sucking the nectar of flowers through a long tubular mouth, and which lays eggs (if a female) before it dies, usually on or near the caterpillar's food plant. This progression is less readily seen in such insects as greenflies, where, although it exists, the changes are less profound and the insect is active in all its stages.

Reference has just been made to the different modes of feeding seen in the adult moth as contrasted with the caterpillar. The former obtains its food by sucking, the latter by biting. This distinction is very important, and serves to divide two great groups of insects from one another so far as their work in the garden goes, viz. those which bite, and those which pierce the tissues of plants and suck the sap. *The latter thus obtain their food from the interior of the plant, and it is impossible to poison their food without at the same time killing the plant*; the former eat both inner and outer parts of the plant, and it is possible to cover the food with a poison which will not find its way into the plant, but which will be swallowed, and will kill any insect that bites the plant. This method of attack cannot of course be followed in dealing with those insects

## Mode of Feeding

that burrow into the tissues like the grubs of the chrysanthemum leaf-miner, or the caterpillars of the goat-moth or leopard-moth which feed on the wood of trees. Nor is it possible to reach the insects that feed underground by means of poisons applied to their food. Nevertheless, this distinction between insects made by their manner of feeding is of enormous importance, and the latter is one of the first things to ascertain regarding any pest with which we may have to deal. The following Table shows the principal biting and piercing and sucking insects affecting plants.

### *Insects Feeding by Biting or Gnawing*

Caterpillars of all butterflies and moths.  
Larvæ (usually caterpillar-like) of all sawflies.  
Grubs of beetles and the mature beetles themselves.  
Grubs of two-winged flies like the onion, carrot, and celery flies, and the daddy-longlegs.  
Wasps and ants.  
Thrips.  
Earwigs, cockroaches, crickets.

### *Insects Feeding by Piercing and Sucking*

Greenflies and other aphides in all stages.  
Scale insects in all stages.  
Plant bugs, including the cuckoo-spit insect in all stages.  
Two-winged flies generally in mature stage.

The second most generally significant thing in the life of the insect is the fact that it breathes through several holes (called spiracles) ranged along the sides of the body, and communicating with tubes which convey the air throughout the body. It is

## Life-histories

therefore possible to suffocate insects by covering these holes, a matter to which we shall again refer. These holes may be easily seen in many caterpillars, as their positions are frequently marked by different coloured spots on the sides of the joints.

The third important thing to know is the life-history : to discover at what stage the insect is capable of doing damage, and at what period in its life it is most open to the application of methods of repression. For example, it is easier to cut out the egg-bracelets of the lackey-moth during pruning in winter than to destroy all the caterpillars by spraying in spring ; it is easier to kill all the caterpillars by waiting until they have entered their tents at dusk and then cutting them out than to wait until they are larger grown and attempt to deal with them by hand-picking ; it is easier to deal with the grown caterpillar than to collect the chrysalides, or to capture the moths. To gain the knowledge necessary for effective dealing with individual pests entails the most careful and detailed examination into the habits and life-stories of the pests, and this is still in progress in connection with many of them. Such detailed accounts would take far more space than is available in the present little book, but it is hoped that the plan adopted will prove useful in indicating not only general methods, but special methods in particular cases.

## CHAPTER VIII

### THE GENERAL SYMPTOMS OF INSECT AND MITE ATTACK

THE presence of insects is generally easy to detect, and where the damage done is suspected to be of insect origin search should be made diligently to discover their presence.

The common symptoms of insect attacks are :

#### I. SYMPTOMS PRODUCED BY BITING INSECTS

1. Clean-cut holes in the tissues : caterpillars, larvae of sawflies, grubs, beetles, cockroaches, crickets.

[*N.B.*—Other causes for such holes are :

- (a) Attacks of slugs or snails, when usually there will be slimy tracks on or near the damaged areas, and of woodlice.
- (b) The results of attack of shot-hole fungi, when the hole is usually surrounded by a brown corky line.

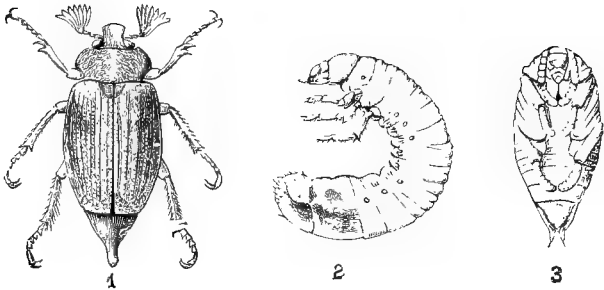

COMMON COCKCHAFER.

1. Cockchafer. 2. Grub. 3. Chrysalis.

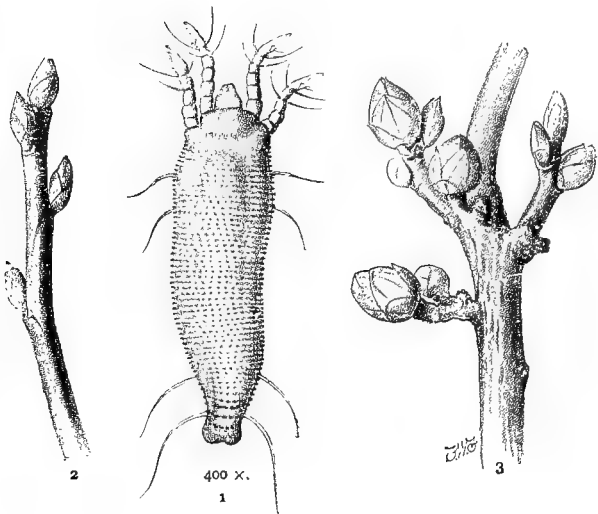

BLACK CURRANT GALL MITE.

1. Black Currant Gall Mite (magnified 400 times). 2. Twig of Black Currant with healthy buds. 3. Twig of Black Currant with infested buds.

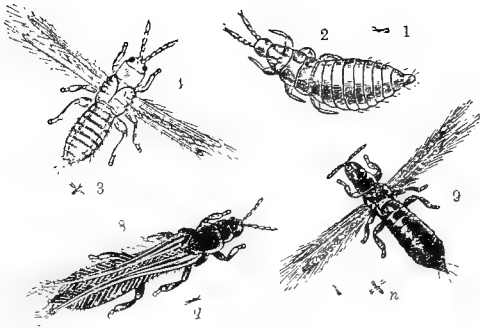

### THRIPS.

1 and 2. Immature Thrips. 3 and 4. Mature Thrips.  
8 and 9. Other Species of Thrips.

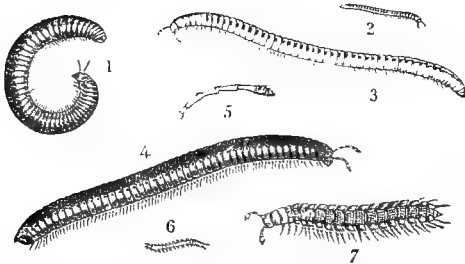

### SNAKE MILLPEDES.

1. *Julus londinensis*. 2 and 3. *Blanjulus guttulatus* (nat. size and mag.). 4. *Julus terrestris*. 5. Teller. 6 and 7. *Polydesmus complanatus* (nat. size and mag.).

## Insect Injury

(c) The result of damage to the bud by the beak of a bird or similar injury.]

2. Scalloped edges to leaves : weevils, especially pea and bean weevils.

3. Borings in stems : caterpillars of goat-moth, wood leopard, clearwing moth in apple or currant ; shot-hole borer beetle, bark beetles, etc. ; pith moth (apple, etc.) ; raspberry moth.

4. Blisters in foliage : caterpillars of blister-moths on apple, blackberry, etc. ; celery fly, parsnip fly, chrysanthemum or marguerite fly, etc.

5. Destruction of buds : carnation fly ; swede and cabbage midge, causing " blindness " in all kinds of cabbage, cauliflower, and swede plants ; bud moth (apple, etc.)..

6. Destruction of roots : cabbage-root maggot, wireworm, leather-jacket, chafers, including cockchafer, rose chafer, garden chafer, pea and bean weevil grubs ; caterpillars of ghost moth.

7. Destruction of lower part of stem so that plant topples over : pests mentioned under No. 6, with addition of onion maggot and surface grubs (caterpillars of various brown night-flying moths, which hide in soil by day).

8. Tunnelling in roots : wireworm, grub of carrot fly.

9. Tunnelling in fruit : caterpillar of codling moth (apple), larvae of sawfly (apples, etc.), currant

## **Insect Injury**

moth, grape moth ; raspberry beetle grub (raspberry, blackberry, loganberry).

10. Holing fruit : caterpillar of winter and other moths (apple, pear, etc.) ; tomato moth ; garden chafers ; wireworm, ground beetles (strawberries) [*N.B.*—The last are also attacked by slugs, millepedes, and birds], wasps, ants, earwigs.

11. Parts of flowers devoured : garden chafers, rose chafer, raspberry beetles (raspberries, etc., and strawberries), mustard beetle, apple blossom weevil ; earwigs.

12. Bark gnawed or buds eaten out : raspberry or vine weevil.

13. Upper or lower surface of leaf destroyed, and leaf skeletonised or only one surface left : sawfly larvae, *e.g.* pear and cherry, rose, spiraea.

14. Leaf rolled on itself, or two or more leaves fastened together by silky threads : various caterpillars, especially of minute moths ; larvae of sawflies, *e.g.* rose ; leaf curling midge of pear.

[*N.B.*—The rolling is sometimes done by larvae, sometimes it occurs as the result of egg-laying ; the object in either case is to provide a shelter for the larvae and chrysalides.]

15. Tents of numerous silky threads : caterpillars of lackey (various colours, in stripes), lesser ermine moth (cream with black spots) ; etc.

16. Borings into seed (especially peas and beans) by beetles.



## Insect Injury

### II. SYMPTOMS PRODUCED BY SUCKING INSECTS

17. Minute holes accompanied by puckering of the leaves, but without insects present at the time : bugs have punctured the young leaves and stem in the bud.

18. Curling and often discoloration of the leaf, accompanied by the presence of greenfly (aphides), or their cast skins—caused by the greenflies of apple and plum (some species), cherry, etc.

19. Spittle-like spots on foliage of various kinds, and on young shoots : the bug known as the cuckoo-spit.

20. Drops of a sticky consistence among flower-buds and young leaves of apple (Apple Psylla) and pear (Pear Psylla).

21. Honeydew on leaves : greenflies or scale insects. [Bees often visit plants for this honeydew, and ants do the same, obtaining it straight from the insects. Whenever ants are seen to be busy on plants search should be made for greenflies or scale insects.]

22. Black fungus growth on leaves : *Fumago* sp. grows on honeydew, and is a sign of the presence of greenflies or occasionally of scale insects.

23. Flowers develop in a one-sided way, *e.g.* chrysanthemums, buds grow only on one side ; apples, and occasionally pears, show roughened warts : they have been punctured by bugs during their development.

## Galls

24. Woody plants show curving of shoots, *e.g.* in apples, currants, and gooseberries, usually accompanied by a discoloration of the bark: early aphid attack.

25. Woody plants show stunted growth and general unthriftiness: they should be closely examined for scale insects on the bark.

26. Palms, ferns, and aspidistras, etc., show discolored spots on the leaves or leaf-stalks: search should be made near the "crown" and mid-ribs for scale insects.

### III. GALLS, THAT IS, ENLARGED GROWTHS, PRODUCED

27. The attacks of insects and other animals of many different types result in enlarged growths which take on extraordinarily different forms according to the kind of insect and the kind of plant. The galls upon the oak illustrate this in a remarkable way, and perhaps no more remarkable story is to be found among the annals of insect life than that of the gall insects of the oak. This is not the place to do more than refer to the fact that oak-apples, artichoke galls, marble galls, spangle galls, currant galls, and many others, all of which may be found in practically any oak coppice, are the result of insects of various kinds laying eggs in the oak, the grubs which hatch from them being found in the galls and feeding upon their tissues.

## Galls

[*N.B.*—Similar enlarged growths formed by fungi have already been referred to, *e.g.* azalea gall, club-root, wart disease of potato, leaf-curl of peach, crown gall. In these no insect is to be found.]

The principal galls calling for mention as needing attention in the garden are big-bud in black currants (due to a mite; the big-bud of hazel is similar but distinct); leaf-blister galls of pear leaves; rose galls (Robin's pincushion, and the round swellings on rose leaves); weevil galls on cabbages and turnips (usually near "collar" of plant, but not underground like club-root, a much more serious pest); woolly aphid galls on apple, etc.; aphid galls on poplar leaf-stalks; Phylloxera galls on vine roots.

### IV. OTHER SYMPTOMS

28. Tiny flecks of whitish colour over the whole or a great part of the surface of leaves and flowers: thrips (often called thunder bugs).

29. Similar discoloration or brown or reddish or even fiery red markings, with a fine web on lower surface: red spider (a mite—not an insect).

30. The presence of excrement or the remains of partially devoured tissues; *e.g.* bulb mites leave a dust-like mass in the bulbs they destroy. The mites themselves are like grains of sand in this debris.

## CHAPTER IX

### METHODS OF DEALING WITH INSECT ATTACK

#### GENERAL

I. *Thorough Cultivation*.—Deep digging and constant hoeing not only in themselves tend to the healthy growth and development of the plant, but result in exposing many noxious insects to the observation of birds, and in disturbing them so that their depredations are lessened, and in some cases, as with the wireworm in the pupal stage, they are actually destroyed. Closely connected with this is—

II. *Timely Application of Manures*, such as nitrate of soda, to bring the plants through a period of attack and enable them to overcome to some extent its effects. Special applications of I. and II. are found in connection with the grubs of chafers which feed on roots of almost all sorts, wireworms, leather-jackets, and *Bibio* (or St. Mark's flies), and caterpillars of the garden swift moth. And of II. in attacks of the turnip flea beetle and pea and bean

## Cleanliness

weevil, both of which feed on young plants, in the first case of all kinds of plants belonging to the cabbage family, including wallflowers and stocks, and also on mignonette, etc., and in the second especially on the two plants mentioned.

III. *Cleanliness*.—The prompt removal of all refuse and its proper disposal either by composting, burial, or burning are great aids. This applies to all parts of the garden, and to trees as well as to herbaceous plants. Woody parts should be burned, soft parts, unless diseased, composted or used as green manure.

Hedge bottoms and banks, rough grass, and so on, should also be attended to, for in such places as these many pests hibernate; *e.g.* turnip flea beetles, weevils, and the like, as well as woodlice, slugs, and other pests not insects. Stones, bricks, and such plants as thrift used as edgings to beds are frequently harbours for pests and as such need particular attention, and under stones the jelly-like eggs of slugs and snails are frequently to be found.

Crevices in walls of greenhouses and upon which trees are trained often serve as hiding-places for various pests. They should be reduced to a minimum by pointing, and where necessary painted or whitewashed at intervals.

All loose bark should be removed from vines during the winter.

Walls and fences around gardens often form

## Egg Destruction

winter shelters for the angular slate-coloured pupae of the cabbage butterflies. They should be searched out and destroyed.

A special method of cleansing should be adopted with fruit trees and bushes, and with ornamental trees which are not too large to deal with. Moss, lichen, and loose bark all afford lurking places for insect pests, and may be removed by spraying with caustic soda (1 lb. to 10 gallons of water) between November 30 and February 15. This must be done only in the dormant season, and only on trees and shrubs that drop their leaves completely in autumn.

IV. *Destruction of Eggs*.—There is a widespread belief, sometimes fostered by advertisement, that caustic winter washing destroys insect eggs. This belief is erroneous. No wash that can be safely applied will destroy insect eggs. When the eggs are about to hatch a proportion of the young may be destroyed, and hence late use of this spray (mid-February) is likely to be productive of more good than early, but that is all. The spraying also loosens many scales under which eggs of scale insects were lying, and these are liable to be destroyed.

Hand-picking of eggs where they are laid in masses can be adopted with advantage.

The eggs of the lackey moth are laid as bracelets round twigs of fruit and rose trees, and may be pruned out during winter; the cocoons of the vapourer moth and of the gold tail, and the egg

## Egg Destruction

masses of the March moth, and a few others, and also at times of the lesser ermine (but these are as it were glued over and more difficult to see) may be similarly dealt with. The large cabbage white butterfly also lays its yellow eggs in groups, and the destruction of these will go far to keep this pest in check.

The gooseberry and currant sawfly lays its eggs in April in slits along the leaf-veins of its food plants, and again in June. Search for these will avert the disaster a severe attack of this pest brings in its train. See also under III. for eggs of slugs and snails.

While winter pruning is in progress close observation should be kept upon the trees to discover eggs and hibernating stages of pests. The younger shoots may be covered with the shining black oblong eggs of one or other of the species of aphis, or the apple spurs and young twigs will bear the drab elliptical eggs of Apple *Psylla*, or the green (later orange) eggs of the winter moth tucked singly into crevices, as well as those of the insects enumerated above. Various small caterpillars may also be discovered and plans laid for their destruction as soon as circumstances permit of measures being taken.

V. *Prevention of Egg-laying.*—In certain cases measures may be taken to prevent egg-laying (see also trapping). The use of substances obnoxious to insects may drive them to other gardens or districts.

## Prevention of Egg-laying

The most frequently used of these substances is paraffin. It is used in three ways. (1) As an emulsion for spraying chrysanthemums, marguerites, and celery against the marguerite and celery flies respectively. The emulsion must be used at summer strength and applied from March onwards to the former and May onwards to the latter plants. (2) For damping sand or sawdust to sprinkle along the rows of seedling cabbages, cauliflowers, and similar plants, and onions, to deter the respective flies [cabbage root fly (see below) and onion fly] from visiting the plants, beginning in May or earlier in very early districts, and repeating at ten-day intervals. (3) For the same purpose where the onion fly is concerned, strings carrying at intervals pieces of rag may be stretched above the onion bed and the rags damped by dipping in a jar of paraffin once every fortnight from early May onwards. The same measure might be tried with the carnation fly, and possibly the narcissus fly.

Naphthalene (often called "carbon") is used to sprinkle on clothes to prevent the clothes moth from laying its eggs, and camphor has the same effect. Crude naphthalene is the basis of several proprietary articles that are used to drive insects from plants and are known as soil-fumigants and recommended as means of guarding plants from the attacks of wireworms, etc. When camphor again becomes lower in price camphor water sprayed or



## Prevention of Egg-laying

sprinkled over cabbages when the white butterflies are on the wing will check egg-laying by them. Meanwhile pyridene compounds might be used on any but those soon to be eaten.

When cabbages or cauliflowers have been planted tarred felt or cardboard discs may be placed round the stem and pressed close to the ground. These do not prevent egg-laying, but do prevent the fly from laying its eggs near to the cabbage stem, and so ensure that the grub dies before it reaches its food plant.

### VI. *Prevention or Postponement of Egg-hatching.*

—A coating over eggs may postpone if it does not altogether prevent their hatching until the food plant has grown so much that the harm the insects will do is greatly diminished. Aphis and Psylla eggs on fruit trees may be so treated by means of lime washing or spraying with lime-sulphur.

Spraying with caustic wash or strong paraffin emulsion is an aid to preventing the hatching of the eggs of scale insects, since the shelter the scale provides is often removed by this winter spraying.

### VII. *Poisoning or Suffocation of Insects in the Active Stage by Spraying.*—The chief ends of spraying against insect attack lie in the direction of poisoning biting insects by the food they eat, or all insects through their skins, or by suffocating them by covering their breathing pores.

Where biting insects are alone concerned the

## Poisoning Insects

best spray is lead arsenate (1 lb. to 20 gallons of water). This may be used for all biting insects, including caterpillars, larvae of sawflies, and beetles, so long as the parts to be sprayed are not to be eaten. It is safe to use on trees bearing *young* fruit, and on young cabbages and turnips that have not developed the edible parts, but not on old ones, or on fruits that are well developed. It is of course useless to spray against insects that feed upon parts of plants which the spray cannot reach. It is the best spray to use against all caterpillars that feed upon fruit trees and roses in early spring, including the winter and allied moths, cigar-case bearers, etc., and all the leaf-eating and bark-gnawing weevils and the raspberry and loganberry beetle; and is useful against the turnip-flea beetle feeding on the seedling cabbages, etc.

Where gooseberries are to be picked green lead arsenate is not safe to use, but hellebore powder may be dusted on the bushes attacked by gooseberry sawflies, or mixed with water and sprayed on.

It should be clearly understood that this spraying should be done at the season at which the pest aimed at begins its feeding; that the insects themselves need not be covered with the poison but their food must; that trees or plants in bloom should not be sprayed with lead arsenate, since bees may be killed.

Where codling moth attacks apples, spraying

## Spraying

should be done with the lead arsenate within three weeks of the fall of the petals so as to catch the caterpillar before it enters the fruit.

For sucking insects sprays containing nicotine are the most effective. They kill through the skin, and young caterpillars and even the raspberry beetle may also be killed by it. Where both aphid or *Psylla* and caterpillars are attacking fruit trees in spring this is therefore the best spray to use, and it is most effective if applied just before flowering in the case of apples, just after with pears, cherries, and plums. The attacks of Capsid bugs upon apples are only to be dealt with effectively by means of a nicotine wash applied when the active green bugs are piercing the young fruits in May, the results of their work being conspicuous in autumn in the shape of rough warts on the surface. The same should be used where bugs are attacking flower buds, etc.

Paraffin emulsion and quassia and soft soap are also useful sprays against aphides, and recently a very efficient spray containing saponin instead of soft soap has been devised. All of these kill by suffocating the insects hit. They do not poison the food, and it is useless to use them unless the insects are present and in a position to be wetted thoroughly with the spray.

VIII. *Suffocation by Dipping.*—Where plants in pots attacked by aphid or scale have to be dealt with, and especially where they are attacked by mites, as in

## Hand-picking

the case of Cyclamen, Begonia, Gloxinia, and the like, dipping is an excellent treatment. The foliage alone is dipped in a solution made by dissolving in  $1\frac{1}{2}$  gallon of warm water a handful of soft soap into which flowers of sulphur have been well kneaded.

IX. *Hand-picking*.—Where cabbages approaching maturity are attacked by caterpillars, or where the attacks of the gooseberry sawfly or the magpie moth caterpillars on gooseberries and currants have been neglected until the fruit is nearly ready for use, hand-picking is the only safe method to adopt. Surface grubs (caterpillars that hide under ground and feed on plants at night) are often best dealt with in this way too. Early in the season, just after the caterpillars of the cabbage white butterfly and the gooseberry sawfly hatch out, they feed in companies and may be collected and destroyed with little trouble. Several fruit-tree-feeding caterpillars form webs to which they retire at night or in damp weather, and these may readily be cut out from the trees when the caterpillars are at home and the whole colony destroyed. Leaf-rolling caterpillars may also be dealt with best by hand-picking. Slugs and snails are best dealt with by visiting their haunts at night armed with a powerful light and a pair of scissors, or a hat-pin, and a pail containing some salt water or paraffin.

Brushes may be obtained wherewith to remove the hordes of greenflies that locate themselves upon

## Hand-picking

tender shoots, although spraying is generally preferable.

A modified form of hand-picking is used with mealy-bugs, which are touched by a brush wet with methylated spirit, and woolly aphid upon apple tree are treated in the same way.

None of these methods are capable of use on a large scale, nor is the commonly employed method of pinching between finger and thumb the blisters made by the grubs of the celery fly, and the marguerite or chrysanthemum fly, effective as it is on a small scale. Where only a few plants have to be dealt with these methods are not to be despised. Hand-picking too is the only method to adopt when roots of plants in pots are attacked by wireworms or weevil grubs (*Otiorrhynchus*).

A combination of the dipping method and hand-picking has often to be adopted where scale-insects attack plants. The scales often cling so closely to the stalks and leaves of palms, orchids, and so on, that their removal with a blunt stick and the sponging of the foliage with the soft-soap-sulphur dip referred to on p. 134 is desirable.

The collection of the grey angular chrysalides of the white cabbage butterfly from their winter quarters under the rails of fences, window ledges, and so on, would be a material help in checking the ravages of this pest upon our vegetables.

Wormy apples too should be collected before the

## Collecting Pests

sawfly or the codling moth caterpillar, as the case may be, leave them for their winter quarters. Pigs make excellent collectors. Pears are often caused to drop prematurely by the pear midge, the grubs of which, hatched from eggs laid in the flower, live and feed in the young pear to the number of about forty. By mid-May the pear attacked has greatly increased in size and often begins to turn black. All such should be collected and destroyed before the grubs fall out to the earth to hibernate.

Both apples and currants are attacked at times by the caterpillars of clearwing moths that bore into the shoots and cause them to wither. These shoots should be removed as soon as the damage is apparent and burned with the culprit inside.

X. *Shaking*.—A few beetles are better collected by shaking the attacked plants over a sheet spread beneath than by any other method. The weevils (*Otiorrhynchus* sp.) that attack fern-fronds, and leaves and shoots of vines at night and other plants growing under glass, are best dealt with so, and nothing is so effective when these same weevils feed upon raspberry canes. When the dead unopened blossoms in the trusses of the apple betray the presence of the apple blossom weevil this method too should be used, but in this case it will be effective in the daytime, while in the other cases after dark is the best time, since the weevils concerned generally hide in the daytime,



**A GREASE-BAND IN COURSE OF PREPARATION.**  
These bands should be made of strong grease-proof paper about 6 inches wide.

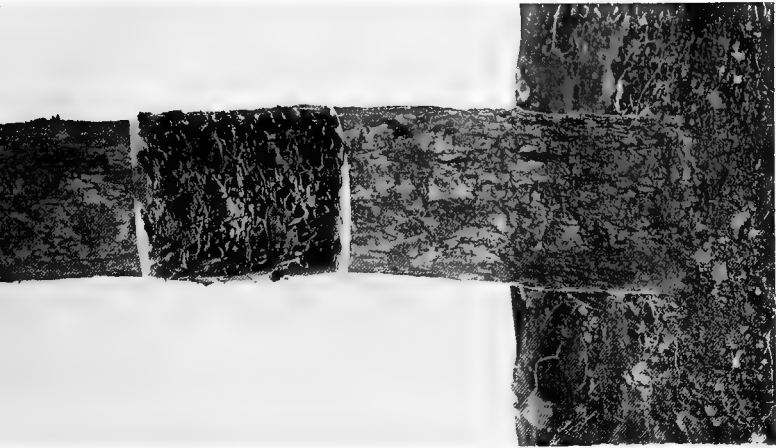

**GREASE-BAND READY FOR USE.**  
Cart-grease may be used, but specially prepared grease may be obtained from hot-ticultural stum resmer.



A TRAP FOR THE CATERPILLARS AS SOON AS THE  
APPLES BEGIN TO FALL.

It is made with folded sackling secured to the trunk of  
the tree 129 to 18" from the ground, with the folded part  
uppermost.

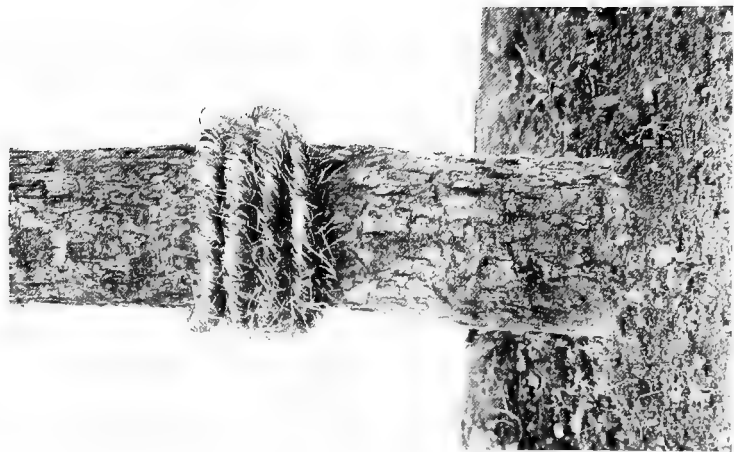

AN ORDINARY HAY-BAND FIXED ABOUT 18" FROM  
THE BASE OF AN APPLE TREE.

This forms a good hiding-place for the larvae.



## Trapping

often in the soil, where their eggs are laid and where their larvae feed.

XI. The chrysalides of many sawflies, such as those attacking the apple, pear, cherry, gooseberry, rose, and Solomon's seal, are formed about two inches beneath the surface of the soil and remain there throughout the winter. They may be destroyed by skimming off the top two inches or so and burning it during winter or burying it deeply. Sawflies rarely travel far, and this prevents the persistent return of the attack which so frequently occurs.

XII. *Trapping*.—The females of the winter moth, mottled umber and March moth, are practically wingless, and they have therefore to walk up apple, pear, and plum trees in order to deposit their eggs near the tips of the shoots. The tying of a band of paper about 5 inches deep around the stem of the tree at a height of about 3 feet from the ground, and keeping upon it a ring of sticky grease from the beginning of October to the end of March, will effect the capture of the majority of these moths, which will die on the "fly-paper" so made. Haybands similarly tied in late August round the trunks of trees attacked by codling moth will afford shelter for the caterpillars, which leave fallen fruits and seek a crevice in the bark to hibernate. But lead arsenate spraying in May is better (see p. 132).

Where slugs are prevalent cabbage or lettuce leaves laid on the soil surface near their haunts will

## Trapping

lead to the capture of many. They should be examined daily.

Millepedes and soil insects like wireworms are best trapped. Pieces of potato or carrot are buried about an inch below the soil, the place being marked with a stick. The traps are examined daily and the captives killed. Potatoes halved and hollowed out, placed with the hollow side down on soil near the haunts of woodlice, will capture these troublesome pests. The traps need daily attention, and as with all these pests, hot water or water with paraffin floating upon it will prove the best thing to kill the captives with.

Earwigs often eat the petals of flowers. They shelter during the day, and inverted flower-pots stuffed with hay and elevated on stakes or lengths of old bean stems laid near the infested plants will act as excellent traps for them.

One or two ground beetles (as well as millepedes and thrushes) eat holes in strawberries as they ripen. They are best destroyed by trapping in basins or smooth tins sunk up to the rim in the surrounding earth and baited with a piece of "lights." These captures will be made mostly at night.

Many moths are attracted by a light, and this is sometimes made use of to capture pests. The results are not, however, altogether satisfactory. Poison baits too may sometimes be employed where it is certain that domestic animals, including bees,

## Boring Insects

will not be likely to be injured. For surface grubs, cockroaches, and the *Otiorrhynchus* weevils heaps of clover dipped in lead arsenate may be placed on the soil near the plants attacked. For two-winged flies like the onion fly and for ants, syrup to which arsenic has been added will prove attractive and deadly.

Trees in a weakly condition often form attractive traps for bark beetles (*Scolytus*) and boring insects such as the shot-hole borer (*Xyleborus*). If they are cut down when the pests are at work and promptly burned the pests will be destroyed.

Bread treated with phosphorus paste is useful not only against mice and rats but against cockroaches, two or three species of which often do a great deal of damage to plants growing under glass. Even more effective is an ingenious trap where bran is the bait and an enclosed water reservoir the death-trap.

**XIII. Direct Action.**—Where large boring caterpillars like the goat moth in willow, ash, elm, or chestnut, and the wood-leopard in apples, pears, and other trees are at work, the most effective method of treatment is to thrust a sharp-pointed piece of wire into the burrows where fresh sawdust is to be seen. If it comes out wet its work is done.

**XIV. Fumigation.**—Where insects are feeding in enclosed spaces, or where they can be enclosed, the most effective treatment is to fumigate. The effect of smoke from a tobacco-pipe upon greenflies is well known to all, and nicotine preparations are put upon

## Fumigation

the market by various firms for fumigation purposes at the present day. Greenflies, white flies, and scale insects in greenhouses are best dealt with by this means.

Fumigation with hydrocyanic acid is even more effective, but its use in careless hands or in greenhouses attached to dwelling-houses is fraught with danger to human life. All cracks should be closed for any form of fumigation, and the air of the house and the foliage of the plants should be dry. The process should be carried out after dark, and the house should be ventilated well before it is entered. This is absolutely essential where hydrocyanic-acid gas is used, for the fumes in even small quantities *are deadly to human life*. The materials wanted for the process are potassium cyanide, sulphuric acid, water and a saucer. The sulphuric acid is diluted and placed in the saucer. The potassium cyanide is dropped into the acid after the door of the house has been securely fastened, and the ventilators are opened for at least two hours before any one is permitted to enter the house. -The quantities required are, for every 1000 cubic feet in a greenhouse, 1 oz. potassium cyanide,  $1\frac{1}{8}$  oz. sulphuric acid, and 3 oz. water.

Soil fumigation has recently received more attention than hitherto, and many soil fumigants are on the market. Their frequent effect is to drive soil insects to seek "fresh woods and pastures new."

## Soil Fumigation

Carbon bisulphide is one of the most effective soil fumigants. Holes are bored to the depth of about 6 or 8 inches, one to each square yard, and into each a teaspoonful of carbon bisulphide is poured, the hole being covered up immediately. The liquid is very inflammable and explosive, exceedingly evil-smelling, and rather expensive, but its fumes, while practically innocuous to the roots of plants, are deadly to all animals. Even mice and wasps may be killed by their means, as well as wireworms, leather-jackets, and the ground forms of aphides, such as the woolly aphis and the aphis of the lettuce and of *Primula* roots, *Phylloxera* on vines (but drowning is often effective for that ; the roots are submerged for three weeks), and so on.

## CHAPTER X

### INSECTICIDES, ETC.

#### *For Biting Insects*

FOR biting insects lead arsenate has now superseded Paris Green, London Purple, and so on, since its use is not likely to result in burning of foliage. It should be purchased in the paste form, as that is far easier to mix with water.

#### LEAD ARSENATE

1 lb. paste.  
20-25 gallons water.

#### HELLEBORE POWDER

Hellebore powder is the powdered root of *Veratrum album*. It loses its poisonous properties on exposure to air for some time, and is therefore valuable where edible parts of plants need to be sprayed against biting insects. Dust on dry while dew is on the plants, or mix with water at the rate of 1 oz. to 1 gallon.



GALLS ON FLOWERS OF THE ASH.

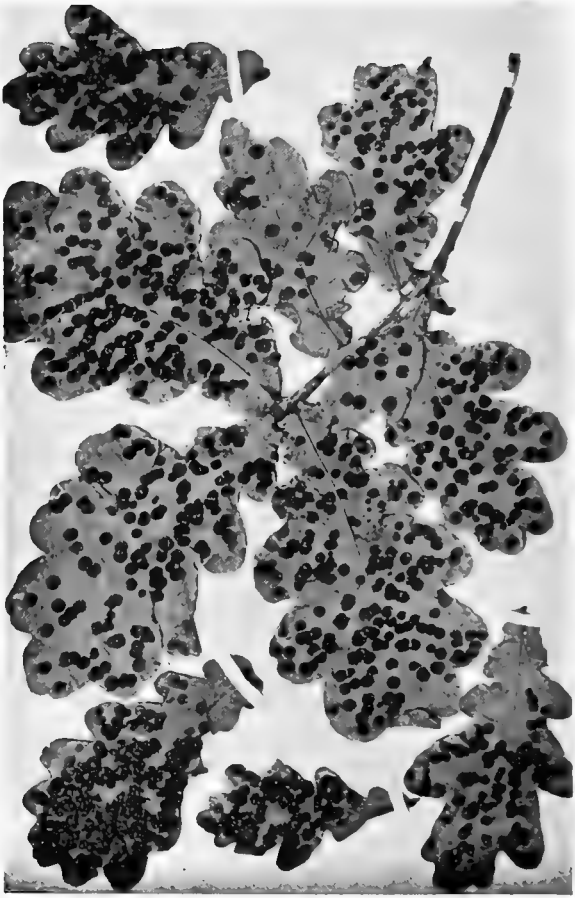

THE OAK SPANGLE-GALL.



## Insecticides

### *For Sucking Insects*

#### NICOTINE SOAP WASH

3 oz. nicotine (95 per cent).  
4 lb. soft soap.  
40 gallons of water.

Dissolve the soft soap in hot water, cool, and add the nicotine, stirring thoroughly. Dilute to 40 gallons.

#### PARAFFIN EMULSION

2½ pints paraffin (good lighting oil).  
¼ lb. soft soap.  
10 gallons water.

Dissolve the soft soap in hot water. When dissolved pour in the paraffin with constant stirring. Then with the aid of a bundle of birch twigs, or better still, with a garden syringe, churn the mixture backwards and forwards until the oil is broken up so finely that the drops do not separate out on standing. This will take 15 to 20 minutes. Dilute with water to make 10 gallons.

This solution may be used in summer. A stronger solution for use in winter is made in the same way, the proportions being :

1 gallon paraffin.  
1½ lb. soft soap.  
10 gallons water.

## Insecticides

### QUASSIA AND SOFT SOAP

1 lb. quassia chips.  
1 lb. soft soap.  
20 gallons of water.

Steep the quassia chips in 10 gallons of water for twenty-four hours. Dissolve 1 lb. soft soap in 10 gallons of water. Strain the water from the quassia chips into the soap solution. Use immediately.

### LIME-SULPHUR

This is best purchased ready-made, and used according to the instructions given for *summer* spraying.

#### *For Mites*

### SOFT-SOAP-SULPHUR DIP

Take a handful of soft soap and knead into it flowers of sulphur, so that all parts are permeated with it. Dissolve the mixture in  $\frac{1}{2}$  gallon of warm water.

### LIVER OF SULPHUR

1 oz. potassium sulphide (liver of sulphur).  
3 gallons water.

Dissolve the liver of sulphur in the water.  
For spraying against red spider.

## Insecticides

### LIME-SULPHUR-SALT-SODA

3 lb. quicklime.  
3 lb. flowers of sulphur.  
3 lb. salt.  
1 lb. caustic soda.  
10 gallons water.

Make the sulphur into a paste, thin and pour over the lime; allow to boil with its own heat; stir and add caustic soda and salt. Bring up to 10 gallons with water.

For spraying pears against the pear-leaf blister mite; used in November while trees are dormant only.

*For Cleansing Trees; used in Winter*

### CAUSTIC WASH

1 lb. caustic soda.  
10 gallons water.

Dissolve the soda in the water.

### LIME-SULPHUR

See notes above—but used at *winter* strength.

### LIME-WASH FOR TREES

Purchase quick-, stone or builder's lime and slake it by adding water gradually in a tub until the lime falls to pieces. Add more water to make a milk, and spray on as soon as possible, covering trunk and branches as thoroughly as possible.

## CHAPTER XI

### FRIENDS OF THE GARDENER

THE insect pests of the garden have themselves many enemies, and although it is probable, and indeed inevitable, that some of the methods advocated for dealing with these pests will themselves result in the destruction of friends as well as foes where the two exist side by side, yet all possible care should be taken to preserve these friends as far as possible.

Among them, birds occupy a high place of usefulness. Most birds when feeding their nestlings catch numerous insects. Some at other times feed entirely upon seeds and parts of plants, and it then comes for consideration on which side the balance lies. Is it to the benefit or to the detriment of the garden products? We have dealt with this question in another chapter, and pass on now to consider insect friends. They may be divided into those that hunt and devour insects, and those that parasitise them.

Of the former the best known are probably the ladybirds. Ladybirds are beetles, and pass through



HOVER FLY (slightly magnified).

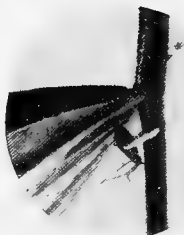

HOVER FLY.

Grub 2 days old, devouring a green fly much larger than itself (magnified 4 times).



The full-grown grub captures a green fly on a pea flower and—



lifting it clear of the leaf—



extends its body in a rigid attitude and sucks the juices of its prey.



The hover fly just emerged from its chrysalis, the broken skin of which is seen above.

*John J. Ward, F.E.S.*



MALE AND FEMALE LADYBIRDS  
FEASTING ON GREEN FLIES.

Note the shrunken skins of their victims.



LARVAE OF LADYBIRD BEETLE  
DEVOURING GREEN FLIES (magnified).



THE LACE-WING FLY.



LARVAE OF LACE-WING FLY FEEDING  
ON AN APHIS (natural size).

*John J. Ward, F.F.S.*

## Insect Friends

four well-marked stages—egg, active larva, pupa, and perfect insect. In the second and fourth the food of ladybirds consists of greenflies and scale insects. Where ladybirds are abundant greenflies rarely do very serious harm. The larvae are slate-coloured with black spots, the pupae are found on the foliage, and can hardly be mistaken for anything else if larvae and ladybird are known; the yellow eggs standing on end are conspicuous on the leaves in spring and summer; the winter is passed in the perfect stage.

The larvae of the lacewing fly also devour greenflies. The curious eggs fixed to leaves by transparent threads a quarter of an inch long are well known objects which often excite curiosity. The flies themselves with green bodies, golden eyes, and large gauzy wings also attract attention, while the repulsive odour they exude when touched render them almost immune from destruction.

Hover flies are well known to all from their habit of hovering over flowers. Most of them feed on pollen, but their rather slug-like brown or green larvae feed, as a rule, on greenflies.

Earwigs, ants, and wasps devour many insects, but their good services on this side have to be balanced against damage done to plants or fruits on the other. The solitary wasps are, however, wholly friendly in their habits, and their nests in hollow sticks and the like should be preserved—

## Ground Beetles

they are full of caterpillars or flies destined for the food of the young. Ants rarely do direct harm to plants, though they eat into apples, etc., damaged by birds. They preserve greenflies, however, and carry them, when their food supplies begin to fail, to other plants, while their nests are a nuisance on lawns and fields.

The numerous population of the soil contains many friends. Insects provided with long legs and (or) powerful wings, large eyes, and conspicuous jaws, are unlikely to feed mainly on plants. They are equipped with the implements of the hunter, and the soil abounds in such. They are mainly beetle larvae and the perfect beetles which develop from them. The larvae of these beetles often meet an untimely death, because they are often straw-coloured, have a hard skin and six legs, and are therefore mistaken for wireworms. They are, however, quite easily distinguished, if only by their active movements. Their jaws are much more conspicuous, they are of stouter, flatter build, and generally have brown markings on the body as well as the head. The active black or violet beetles are often very abundant, and are familiar to all. One or two species have been referred to as attacking ripe strawberries, but this is the only damage traceable to them. The devil's coach-horse, or cocktail beetle, is another friend, and it and its black larva are common in town and country.



## Parasitic Insects

*Parasites.*—In addition to the insects that hunt garden pests, there are many others that feed inside them or in their eggs. These parasites belong to various families of insects, but the most familiar are the ichneumons. They are easily recognised by the abdomen being attached to the body by a thin stalk, by the long egg-laying apparatus projecting from the end of the body, by which they penetrate the body of their prey, and by their long quivering antennae. The variety of these ichneumons is very great, for most caterpillars are subject to the attacks of one or more species of ichneumon, and generally each species of parasite is confined to one species of host, while many of the parasites are themselves subject to the attack of other parasites.

The eggs of the parasite are laid either in the egg of the host or in the body of the larva. The grubs that hatch from these eggs may pass their whole life in the egg of their host, finding sufficient sustenance to secure full development therein; others feed in the body of the larvae until that is full-grown without damaging any vital part. Some emerge from it while still in the larval stage, others not until it has assumed the chrysalis stage. The masses of cocoons of one ichneumon are familiar to every grower of cabbages. The caterpillars of the cabbage-white butterfly are parasitised by it, and when they are full-fed the parasites eat their way out through the skin, spin cocoons, and become

## Parasitic Insects

chrysalides therein, to emerge in due course and parasitise other white butterflies. These masses of cocoons are often destroyed in ignorance. They should be preserved.

But for natural checks to their increase, we might look to these parasites to do all necessary for the control of pests. Unfortunately in the artificial conditions of our gardens their work is not entirely successful; this partly because parasitised caterpillars become sluggish and fall easy victims to birds, and the parasites are themselves often destroyed by parasites.

Not only are caterpillars liable to be parasitised, but all other pests. The brown skins, somewhat distended, of greenflies are by no means infrequent on the underside of the foliage they frequent. Close examination reveals a minute hole in the skin, showing where the parasite has emerged and left the skin otherwise intact. Others still remain intact, the parasites in them. Other insects may similarly be attacked, while sometimes fungi are parasitic upon pests and bacterial or fungus diseases attack them. The caterpillar of the garden swift moth, for instance, is often found in a "mummy" condition, with the fruit of the fungus which has invaded all the tissues of the caterpillar and formed the mummy projecting from its body.

Another parasite of insects frequently attracts attention since it is found on leaves, especially in

## Garden Friends

warm, damp weather. This is a long white worm looking like a piece of cotton thread endowed with rather sluggish life. It is a worm that lives in the intestines of insects, and is absolutely harmless to human beings.

Reference has already been made to beneficial birds, and among other creatures, not insects, the lizards, frogs, and toads which frequent our gardens must be mentioned. The gardener has no better friends. Spiders, too, are wholly beneficial, so are centipedes,<sup>1</sup> although they often fall victims to the gardener's zeal for destroying pests. Worms, except on lawns and in flower-pots, must be reckoned the friends of the garden, and they have enemies, too, in the garden besides the birds, slow-worms, moles, and so on, in the curious worm-eating shell-bearing slugs (*Testacella*), and in greenhouses the exotic worm *Bipalium kewense*, frequently found among the crocks of flower-pots.

This seems the proper place to mention the beetle-mites (Oribatidae), which live in crevices of bark of fruit trees, sometimes in great numbers. Because their hard reddish bodies are frequent in canker wounds, they are looked upon as a cause of canker, whereas they feed upon fungus spores and lichens, and are therefore friendly. The same may be said of the tiny orange grubs of minute two-winged flies

<sup>1</sup> Centipedes have only one pair of legs to every joint, the harmful millepedes have two pairs to each joint.

## **Garden Friends**

(Cecidomyiidae) that are found on foliage attacked by rust and other fungi. They feed upon the rust spores and help to hold the fungus in check.

It is perhaps rarely that anything can be done to increase the number of these friends, but their lives may at least be preserved from wanton destruction to the general benefit of all plant-growers.



**SPRAYING APPLE TREES AT WISLEY WITH LEAD ARSENATE.**

The spraying is done before the flowers open, and again after the petals fall.

## Spraying

a rule, useless against fungi, and *vice versa*. Bearing in mind what has been said regarding the nature of fungus attacks and insect attacks, it should be clear that the *time* for spraying against fungi is often just before an imminent attack, *e.g.* in the case of potato blight (due to *Phytophthora infestans*) about July 10, while for insects the time is the first onset of the attack.

The best form for a spray is generally that of a fine mist ; only rarely is it necessary or desirable to apply a spray material so as to " wash " the plant treated. Special machines have been devised for the purpose of producing this type of spray. Its formation depends mainly upon delivering the liquid to be sprayed under sufficient pressure (generally 80 to 100 lb. to the square inch) through a suitable nozzle which can be directed towards the thing sprayed, and the direction of which can be easily changed. A strong pump is therefore necessary, and it is convenient if the material to be used can be carried about in such a way as to be directly available for the pump.

For large areas large machines and powerful pumps are required, but for ordinary gardens the machines of the knapsack type are most convenient. Knapsack spraying machines are of two kinds, the continuous pumping and the pneumatic. In the former the pump is worked during the whole time the sprayer is in operation ; in the pneumatic, air is

## Spraying

pumped in so as to get a pressure of 100-120 lb. to the square inch upon the liquid in the container before spraying is commenced. Both types of machine are good, but with the pneumatic type there is some danger of attempting to spray with too little pressure, and there is also the need for testing occasionally to ascertain that the machine is sufficiently strong to withstand the necessary pressure.

In any case the container should hold from three to three and a half gallons of spray, and the machine when charged should weigh about 40 lb. The container may be made of copper unless lime-sulphur is used, when it must be made of some other metal not liable to be attacked by this compound. It should be of a form to fit comfortably upon the back, and have broad shoulder-straps of such a length that the loaded machine will ride easily. If of the continuous pumping type the pump handle should come conveniently to the hand. In both types all parts at all likely to get out of order should be easily reached for adjustment; the valves are best of metal and the washers of leather. Leather is generally preferable to rubber, for the latter is more apt to perish. A supply of washers and spare wearing parts should always be near at hand.

Means should be provided for ensuring that the spray fluid is kept in a state of agitation during spraying. This is less important when the machine

## Spraying

is used and emptied immediately after being filled, but if this is not done such heavy substances as lead arsenate and Bordeaux mixture, where the effective material is not in solution, but in a state of suspension in water, are likely to settle and the spray will then be delivered at unequal strengths, and the work will be to a large extent ineffective.

The pump must be sufficiently powerful to give the necessary pressure, and when spraying commences several strokes of the pump should be given before the tap leading to the delivery nozzle is turned on.

The delivery nozzle is connected to the pump by a length of flexible pipe which must be strong and properly clamped on. By its means the nozzle can be turned in various directions and all parts of the plant covered in turn. The nozzle itself is carried on the end of a metal tube and is one of the most important parts of the machine. There are many patterns, and the exit holes are of many types and sizes according to the work the machine is intended to do, delivering either a coarse spray suitable for lime-washing or a very fine one suitable for Bordeaux spraying. The fine type is most generally useful. It must be easily cleaned, for some of the substances used with it contain fine particles which may sometimes clog it. As a further method of preventing this it is necessary that the machine should be supplied with a strainer, to prevent any



## Spraying

large particles getting into it and finding their way to the nozzle.

Where large trees have to be sprayed long lances may be used to carry the nozzles to the desired height.

Having filled the container and adjusted it upon the back, secured the necessary pressure, turned on the tap so that the mist-like spray is directed towards the plant, see that all parts of it are covered, the lower leaf-surface as well as the upper, continue spraying just so long as is necessary to effect this, then immediately cease.

Spray with the wind, but choose, as far as possible, calm weather for the operation. If rain, especially heavy rain, falls after spraying for fungi and biting insects the operation must be repeated. When spraying with caustic soda (which must never be used on leaves) protect the hands with leather gloves. Spraying is best done in dull weather or in the evening, not in bright sunshine.

*Always* cleanse the spraying machine and nozzle after use and put away dry.

Unless provided with a special nozzle a syringe is a very poor substitute for a spraying machine. It cannot deliver the spray in a sufficiently fine state to do efficient work.

Where powders such as flowers of sulphur have to be distributed, powder bellows should be used so as to get an even distribution. Little has been said

## **Spraying**

concerning dry spraying in this little book, for this method of applying insecticides and fungicides is as yet only in the experimental stage, and the results secured from it are, while encouraging, not yet sufficiently certain in most cases to warrant its recommendation generally.

When spraying has to be done, see that suitable materials are chosen, do it at the right time, do it carefully, and do it thoroughly.

## INDEX

- Acer Pseudoplatanus*, black blotches, 65  
 Acetylene, escape of, 31  
 Acidity, soil, 24, 26, 28  
*Actinomyces chromogenus*, 93  
 Aims of plants, 2  
 Almond, gummy excretion, 65  
 Ammoniacal copper carbonate, 62  
*Anemone coronaria*, 92; sclerotia in roots of, 49, 66; *Puccinia pruni* on, 54, 66, 92  
 Antirrhinum, spots on, 66  
 Ants, 108, 112, 129, 137  
 Aphides, 10, 26, 63, 67, 108, 113  
 Apples, 66-69; bitter-pit in, 39; "mummy," 50, 69; crown gall, 66; canker, 50, 67  
 Arabis, rust, 69  
*Ascochyta clematidina*, 76; *Pisi*, 88, 94  
 Aspidistras, 114  
 Asters, mildew, 70; China, 73  
*Azalea indica*, 70  
  
*Bacillus amylovorus*, 90; *solanacearum*, 94; *tumefaciens*, 66  
*Bacterium Hyacinthi*, 81; *tumefaciens*, 95  
 Barberry, *Puccinia graminis* on, 54, 71  
 Bark gnawed, 112  
 Beans, Broad, rust, 70; Dwarf and Runner, spot, 70  
 Beet, rust, 71  
 Beetles, 108, 110, 111, 116, 126, 129, 136; mites, 141  
 Bibio, 116  
 Big-bud, 115  
*Bipalium kewense*, 141  
 Birds, 103, 104, 110, 112, 136  
 Biting insects, symptoms produced by, 110  
 Bitter-pit, 39  
 Black moulds, 26  
 Bleeding, 38  
 Blisters in foliage, 111  
 Bordeaux mixture, 60  
 Borings, 111  
*Botrytis cinerea*, 79, 84, 88, 90, 95, 99, 101; *B. Paeoniae*, 87; *B. Galanthina*, 98; *B. parasitica*, 100  
 Breathing necessary to plants, 4  
*Bremia Lactucae*, 83  
 Broomrape, 42  
 Buds, destruction of, 111  
 Burgundy mixture, 61  
 Burning, 31  
 Butterfly, cabbage, 118, 119, 124, 125  
  
 Cabbage, 71, 72; root maggot, 111  
 Calceolaria, wilting of, 73  
*Callistephus hortensis*, 73  
 Camellia, blotches on, 73  
 Camphor, 120  
 Canker, 50  
 Carbon bisulphide, 130  
 Carnations, 73-74; rust, 62, 73; smut, 50, 74; fly, 111

# Index

- Caterpillars, 108-135  
Caustic wash, 135  
*Cecidomyiidae*, 141  
Celery, 74; fly, 111, 125  
*Oercospora circumscissa*, 65,  
75; *C. Melonis*, 77, 84;  
*C. Resedae*, 85  
Chalk, powdered, for light soils,  
27  
Chemical constituents, 7, 32  
*Chenopodium album*, 33  
Cherry, 74, 75  
Chickweed, 33  
Chionodoxa, 75  
Chlorosis, 33  
Chrysanthemum, 75, 76, 111;  
fly, 111, 125  
Cineraria, 76  
*Oladosporium herbarum*, 67;  
*C. Scabies*, 78; *C. carpo-*  
*philum*, 89; *C. fulvum*,  
99  
Clematis, 76  
"Club," 44, 48, 49, 63, 72  
Coal-gas, escape of, 31  
Cockchafers, 111, 116  
Cockroaches, 108, 110, 129  
*Oleosporium Senecionis*, 54,  
76, 91  
*Colletotrichum Lindemuthia-*  
*num*, 70; *C. malvacearum*,  
83  
Coltsfoot, 28  
*Coniothyrium concentricum*, 81;  
*C. Fuckelianum*, 95  
Copper compounds, 59, 62  
"Coral-spot," 53  
Crane fly, 30  
Crataegus, 77  
Cress, 77  
Crickets, 108, 110  
*Cronartium ribicolum*, 54, 91  
Cuckoo spit, 108, 113  
Cucumber, 77  
Curl, 39, 40, 47  
Currants, "coral-spot" on, 53,  
78; Black, spores on, 54,  
55, 91; big-bud in, 115  
*Cystopus candidus*, 69; *C.*  
*Tragopogonis*, 97  
Daddy-longlegs, 30, 108  
Dahlias and "Sclerotium," 69,  
78  
Dead parts, removal of, 57  
Delphinium, 79  
Dipping, suffocation by, 123  
Dodder, 28, 42  
Doubling, 41  
Drainage, value of, 5, 26, 28,  
29  
"Drawn" plants, 35  
Dusting, Sulphur-, 59  
Earth-salts, 8, 10, 11, 17, 32,  
34  
Earwigs, 108, 112, 128, 137  
Eggs, destruction of insect, 118;  
prevention of egg-laying,  
119, 121  
*Endophyllum Sempervivi*, 98  
Environment, best, 3  
*Equisetum arvense*, 28  
Erica, 79  
*Erysiphe cichotacearum*, 70, 77;  
*E. polygoni*, 79, 88  
Etiolation, causes of, 36  
Excess of lime, 33; of water,  
35; of fertilisers, 35  
Exhaustion, plant, 20  
*Exoascus deformans*, 65; *E.*  
*bullatus*, 90; *E. Pruni*,  
92  
*Exobasidium japonicum*, 70;  
*E. Rhododendri*, 95  
Fat-hen, 33  
Ferns, 114  
Fig, 79  
Firm planting, 9  
Firs, Scots, fungus on needles,  
54  
Fish and flannel weed, 22; in  
ornamental water, 105  
Flannel weed, 21, 22, 105  
Flowers, parts of, devoured,  
112  
Food making, 11, 17, 26, 36  
Food storage, 17  
Formalin treatment, 58  
Frogs, 141

- Fruit, splitting of, 38; tunnelling in, 111; holing, 112
- Fruit trees, "canker" of, 50
- Fumigation, 59, 129
- Fusarium*, 73, 88; *F. Peltagonii*, 90; *F. Solani*, 94
- Fusicladium dendriticum*, 68
- Galls, 114
- Gas lamps, fumes from, 30
- Glazed pots, 29
- Gloeosporium orbiculare*, 78; *G. fructigenum*, 79, 89; *G. rufomaculans*, 101
- Goat moth, 111
- Gooseberry, hosts on, 54; mildew, 80; picked green, 122
- Goose-foot, 33
- Grapes, burning, 31
- Grass, effect of, on trees, 21
- Grease bands, 127
- Greenfly, 108, 113, 124
- Ground beetles, 128, 138
- Gymnosporangium clavariiforme*, 77, 82; *G. juniperinum*, 82
- Hand-picking, 124
- Hares, 103
- Heaths and lime, 27
- Hellebore powder, 122, 132
- Helleborus, 81
- Heterosporium echinulatum*, 74; *H. gracile*, 82; *H. variable*, 98
- Hollyhock rust, 62, 81
- Honeydew, 26, 113
- Horsetail, 28
- Hover fly, 137
- Hyacinth, 81
- Hydrocyanic acid, 130
- Hydrogen Peroxide treatment, 58
- Ichneumons, 139
- Infertility, curious cause of, 33
- Insecticides, 132-135
- Insects, characteristics of, 106-109; symptoms of, 110-115; methods of dealing with, 121
- Iris rhizome rot, 63, 81
- Juniper, 82
- Lacewing fly, 137
- Ladybirds, 136
- Larch canker, 82
- Laurel, 83
- Lavatera trimestris*, 83
- Lawns, bare patches, 23; moss and weeds, 23, 24
- Lead arsenate, 121, 122, 127, 129, 132
- Leaf-curl, 39, 40, 47, 112
- Leather jackets, 30, 111, 116, 131
- Leaves, functions of, 11
- Lettuce, 83
- Libertella ulcerata*, 79
- Light, value of, 12, 36
- Lily, 84
- Lime, test for, 27; excess of, 33
- Lime-sulphur, 134
- Lime-sulphur-salt-soda, 135
- Lime trees and honeydew, 26
- Liquid manuring, 34
- Liver of sulphur, 59, 134
- Lizards, 141
- London Purple, 132
- Lychnis, 84
- Lysol, 57
- Malva, 84
- Manufacturing districts, standing water in, 30
- Manuring, liquid, 34
- Mare's-tail, 28
- Marssonina Populi*, 93
- Mealy-bug, 125
- Melampsora aecidioides*, 93
- Melon leaf spot, 84
- Mice, 129, 131
- Microsphaera Grossulariae*, 80
- Midge, swede and cabbage, 111
- Mignonette, 85
- Mildew, 39, 44-47, 53, 58

# Index

- Millepedes, 112, 128  
Mint, rust of, 50, 85  
Moles, 104, 141  
*Monilia fructigena*, 69, 75  
"Mosaic" disease, 40  
Moss on lawns, 23, 24  
Moths, 111, 112; lackey, eggs of, 118; codling attacking apples, 122  
Mottling, 40  
*Mucor subtilissimus*, 86  
*Mycosphaerella brassicicola*, 72; *M. citrullina*, 77  
*Mystrosporium adustum*, 82
- Naphthalene, 120  
Napoleon III., mule pink, 20  
Narcissus, 85  
Nectarine, 89  
*Nectria ditissima*, 50, 67; *N. cinnabarina*, 78  
Nettle-leaf, 41  
Nicotine sprays, 123; preparations, 129, 133  
*Nymphæa*, 85
- Oak, 86  
*Oidium chrysanthemi*, 75  
*Olpidium Brassicae*, 71  
Onion, 86; maggot, 111  
Orchids, syringing, 31  
*Otiorrhynchus*, 125, 126, 129  
Overcrowding, 36
- Palms, 87, 114  
Paraffin, 120, 121, 123, 128, 133  
Parasitic insects, 139  
Paris Green, 132  
Parsley, 87  
Parsnip, 87; fly, 111  
Peach curl, 47, 65, 89  
Pear, 89, 126, 135  
Peas, 88  
Pelargonium, 90  
Peony, 86  
*Peronospora parasitica*, 69, 101; *P. Schleideni*, 86; *P. sparsa*, 97; *P. effusa*, 98  
*Pestalozzia Guepini*, 73  
*Peziza Willkommii*, 83
- Phosphorus paste, 129  
*Phragmidium Rubi-Idaei*, 95; *P. subcorticium*, 96  
Phylloxera on vines, 115, 131  
*Phytophthora infestans*, 93; *P. cryptogaea*, 99  
Pine, 91  
*Pinus Strobus*, 54, 55  
Planting, firmness in, 9  
*Plasmiodiophora Brassicae*, 72, 97  
*Plasmopara nivea*, 87  
*Pleospora Oxyacanthae*, 77  
Plum trees, *Puccinia pruni* on, 54  
Plums, 91-93; "mummy," 50  
*Poa annua*, 25; *P. nemoralis*, 25  
*Podosphaera leucotricha*, 67; *P. Oxyacanthae*, 77  
Ponds, flannel weed on, 21, 22  
Poplar, 93  
Potash, value of, 32  
Potassium sulphide, 59; permanganate, 62  
Potato-blight, 52, 93, 94; leaf curl, 39  
Primrose, 94  
Primula, 94  
Pruning diseased parts, 57  
*Pseudomonas campestris*, 72  
*Puccinia Pringsheimiana*, 54, 66, 81; *P. pruni*, 54, 89, 92; *P. graminis*, 54, 71; *P. malvacearum*, 81; *P. lychnidearum*, 84; *P. Menthae*, 85; *P. Vincae*, 100; *P. Violae*, 101  
Pyridene, 121  
*Pythium De Baryanum*, 71, 77
- Quassia, 123, 134  
Quicklime, powdered, 27
- Rabbits, 103  
Radish, 95  
*Ramularia Vallisumbrae*, 85; *R. nymphaeorum*, 86  
Raspberry, 95; moth, 111; beetle grub, 112

- Rats, 103, 129  
 Red spider, 31, 115  
*Rhododendron ferrugineum*, 70  
 Rhododendrons, 27, 95  
*Rhytisma*, 65  
 Roots, general functions of, 6 ;  
     destruction of, 111 ; tun-  
     nelling in, 111  
 Roses, 95, 96 ; mildew, 44-47 ;  
     rust, 62 ; galls, 115  
 Rotation of crops, 62  
*Rumex Acetosella*, 28  
 Rusts, 53-55  
  
 Salsify, 97  
 Sawflies, 108, 112, 119, 122, 127  
 Saxifrage, 62, 97  
 Scab in apples, 68, 69  
 Scalding, 31  
 Scale insects, 108, 114  
 Scillas, 50, 97  
*Sclerotinia fructigena*, 69  
 "Sclerotium disease," 49, 66, 78  
*Scolytus*, 129  
 Seakale, 97  
 Seed protection, 105  
 Sempervivum, 98  
*Senecio pulcher*, 98  
*Septoria antirrhini*, 66 ; *S.*  
     *Dianthi*, 74 ; *S. Petrose-*  
     *lini*, 74, 87 ; *S. chrysan-*  
     *themii*, 76 ; *S. Populi*, 93  
 Shaking, 126  
 Shanking, 37  
 Sheep sorrel, 28  
 Shepherd's Purse, 20  
 Shot-hole fungi, 110  
 Silver leaf, 50, 53, 89, 92  
 Slow-worms, 141  
 Slugs, 110, 112, 116, 117, 124,  
     127  
 Snails, 110, 117, 124  
 Snowdrop, 98  
 Soap, soft, 123, 133, 134  
 Soda, caustic, 118  
 Soda-Bordeaux mixture, 61  
 Soft-soap-sulphur dip, 134  
 Soil, chemical constituents of,  
     7 ; acidity, 24, 26, 28  
 Sour soils, 24, 25, 28  
  
*Spergula arvensis*, 28  
*Sphaerella Fragariae*, 99  
*Sphaeropsis malorum*, 67  
*Sphaerotheca Mors-uvae*, 80 ;  
     *S. pannosa*, 83, 96 ; *S.*  
     *Humuli*, 99  
 Spiders, 141  
 Spinach, 98  
 Splitting, 38  
*Spongospora subterranea*, 93  
 Spore distribution, 43-55  
 "Spotting," 31, 34  
 Spraying, 58-62, 121, 143  
 Spurrey, 28  
 Stem structure, 9  
*Stereum purpureum*, 50, 92  
 Stock, 98  
 Strawberries, 98, 128  
 Sucking insects, 113  
 Sulphur-dusting, 59 ; fumiga-  
     tion, 59  
 Sweet Pea, 99  
 Sycamore, black blotches on  
     leaf-tissue, 65  
*Synchytrium endobioticum*, 94  
  
*Taphrina aurea*, 93  
 Tar, Stockholm or gas, 57  
 Temperature, best, 6  
*Thielavia basicola*, 88  
 Thrips, 108, 115  
 Toads, 141  
 Tomato, 99 ; moth, 112  
 Toothwort, 42  
 Trapping, 127-129  
 Trees, effect of grass on, 21 ;  
     best grass to grow under,  
     25 ; fungus on Scots firs,  
     54 ; large boring cater-  
     pillars in, 129 ; lime-wash  
     for, 135  
 Tulips, fire in, 49, 100  
 Turnip, 100 ; flea beetle, 116, 117  
*Tussilago Farfara*, 28  
  
*Uromyces Fabae*, 70 ; *U. Betae*,  
     71 ; *U. caryophyllinus*, 73 ;  
     *U. Scillarum*, 97  
*Ustilago violacea*, 74, 84 ; *U.*  
     *Vaillantii*, 75, 97

## Index

- Variation, 40  
*Venturia inaequalis*, 68; *V.*  
    *pirina*, 90  
*Veratrum album*, 132  
Verbascum, 100  
Vinca, 100  
Vines, 100, 117  
Viola, 101
- Wallflower, 101  
Warted foliage, 37, 49  
Wasps, 108, 112, 131, 137  
Watering, 14, 15  
Water Lilies, smothered by  
    "flannel weed," 21
- Weeds, of sour soils, 28;  
    harbouring fungus, 57  
Weevil grubs, 111, 112, 117, 125  
Wheat, red rust of, 54  
Winter, fungi in, 50  
Wireworms, 111, 116, 125, 128,  
    131, 138  
Wood leopard, 111  
Woodlice, 110, 128  
Woolly aphid, 63, 67, 125  
Worms, 141  
Wounding plants, 57; trees,  
    103, 104
- Xyleborus*, 129

THE END



## “Country Life” Library of Garden Books

### **GARDENING FOR BEGINNERS : A Handbook to the Garden.**

By E. T. COOK. Coloured Plates and over 200 Illustrations, Plans and Diagrams from Photographs of selected specimens of Plants, Flowers, Trees, Shrubs, Fruits, etc. Seventh Edition. **17s. 6d.** net ; by post **18s. 6d.**

“One cannot speak in too high praise of the idea that led Mr. E. T. Cook to compile this *Gardening for Beginners*. Nothing is omitted.”—*Morning Post*.

### **COLOUR SCHEMES FOR THE FLOWER GARDEN.**

By GERTRUDE JEKYLL. Fourth Edition, revised. **15s.** net ; by post **15s. 6d.**

### **WALL AND WATER GARDENS.**

With Chapters on the Rock Garden, the Heath Garden and the Paved Water Garden. By GERTRUDE JEKYLL. Sixth Edition, revised. Large 8vo, 220 pages. **17s. 6d.** net ; by post **18s. 4d.**

“He who will consent to follow Miss Jekyll aright will find that under her guidance the old walls, the stone steps, the rockeries, the ponds, or streamlets of his garden will presently blossom with all kinds of flowers undreamed of, and become marvels of varied foliage.”—*Times*.

### **TREES AND SHRUBS FOR ENGLISH GARDENS.**

By E. T. COOK. **15s. 8d.** net ; by post **16s. 5d.**

“It contains a mass of instruction and illustration not always to be found altogether when required, and as such it will be very useful as a popular hand-book for amateurs and others anxious to grow trees and shrubs.”—*Field*.

### **THE PLANNING AND PLANTING OF LITTLE GARDENS.**

By GEORGE DILLISTONE. With Notes and Criticisms by Sir LAWRENCE WEAVER. Freely illustrated. **6s.** net ; by post **6s. 6d.**

### **ANNUALS AND BIENNIALS.**

The best Annual and Biennial Plants and their uses in the Garden. By GERTRUDE JEKYLL. With cultural notes by E. H. JENKINS. Illustrated throughout. **9s. 5d.** net ; by post **9s. 11d.**

“A noteworthy addition to the special literature of the garden.”—*The Scotsman*.

# “Country Life” Library of Garden Books

(continued)

**HENRY NICHOLSON ELLACOMBE : A Memoir.** By ARTHUR W. HILL. 10s. 6d. net ; by post 11s.

**THE DISEASES OF TREES.** By Professor R. HARTIG. Royal 8vo. 13s. 2d. net ; by post 13s. 6d.

**SEASIDE PLANTING OF TREES AND SHRUBS.** By ALFRED GAUT, F.R.H.S. 6s. 3d. net ; by post 6s. 9d.

**TULIPS AND DAFFODILS.** By the Rev. JOSEPH JACOB. (*In the Press.*)

**THE BOOK OF BRITISH FERNS.** By CHARLES T. DRUERY, F.L.S. 4s. 5d. net ; by post 4s. 9d.

**THE HARDY FLOWER BOOK.** By E. H. JENKINS. 50 Illustrations and Coloured Frontispiece. 2nd Edition. 3s. 2d. net ; by post 3s. 6d.

“The amateur gardener who covets success should read *The Hardy Flower Book.*”—*Daily Mail.*

**THE ROCK GARDEN.** By E. H. JENKINS. 2nd Edition. 7s. 6d. net ; by post 8s.

**PERPETUAL CARNATIONS ILLUSTRATED.** By LAURENCE J. COOK. 2s. 6d. net ; by post 3s.

**GARDENING MADE EASY.** By E. T. COOK. 200 pages and 23 Illustrations. 2s. net ; Cloth, 3s. ; postage 3d. extra.

“The A.B.C. of Gardening.”—*Scotsman.*

**ROSE GROWING MADE EASY.** By E. T. COOK. 1s. 3d. net. Cloth, 2s. net ; postage 3d. extra.

“. . . Ought to be in the hands of every rose grower.”—*Aberdeen Free Press.*

**FRUIT GROWING FOR BEGINNERS.** By F. W. HARVEY. 2s. 6d. net ; postage 6d. extra.

“An amazing amount of information is packed into this book.”—*Evening News.*







