

PROFITABLE  
POULTRY PRODUCTION

M. G. KAINS

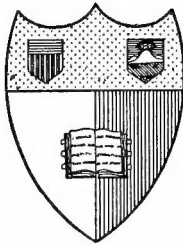

• FARM • LIFE • SERIES •



New York  
State College of Agriculture  
At Cornell University  
Ithaca, N. Y.

---

Library

Cornell University Library  
SF 487.K3 1913

Profitable poultry production,



3 1924 003 691 957

mann

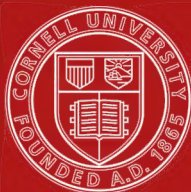

## Cornell University Library

The original of this book is in  
the Cornell University Library.

There are no known copyright restrictions in  
the United States on the use of the text.



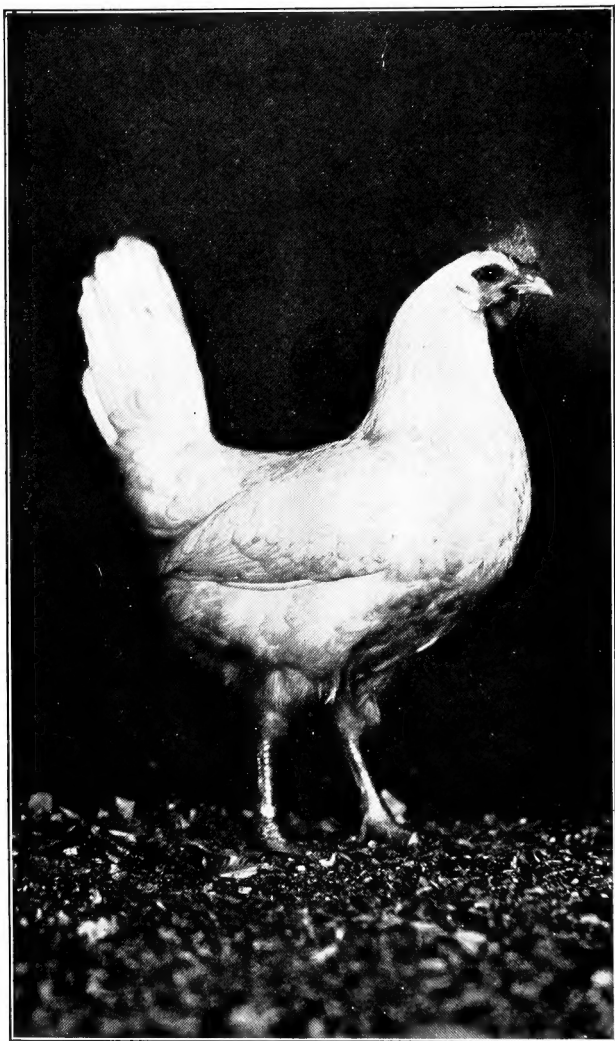

SINGLE COMB WHITE LEGHORN PULLET

# Profitable Poultry Production

*By*

**M. G. KAINS**

*Poultry Editor American Agriculturist Weeklies*

NEW YORK

ORANGE JUDD COMPANY

1913

SF 487

K 3

1913

*Copyright, 1910*

**ORANGE JUDD COMPANY**

**NEW YORK**

© 34472

**Printed in U. S. A.**



## P R E F A C E

**P**OULTRY production is commonly practiced on every farm, but *profitable* poultry production so far as the farm is concerned, is rare indeed. No one, as a rule, has better natural conditions for poultry raising than has the farmer. It is only a matter of embracing opportunities that is wanting.

This book, *Profitable Poultry Production*, is written to present the case fairly and squarely so the farmer may see the advantages that poultry offers as a means of making money. The book lays special emphasis upon all the important practices and new wrinkles that have been found profitable by professional breeders and poultrymen. It shows how these can be easily applied by any one and what may be expected in the way of results. From cover to cover it is intended as an encouragement and a stimulus to everyone interested in poultry. Not only does it indicate which are the lines likely to be most profitable, but it points out those branches of the business not likely to be remunerative, except under special conditions.

When one is telling his own experience or is compiling the experience of others, his words necessarily carry much more weight than if he adopts

the preacher style and says that his hearers should or must do thus and so. The fact that what he writes about has been or is being done is evidence that cannot be set aside. For this reason the author has endeavored to present his subject from the *results* standpoint. With the conviction, therefore, that application of the principles herein laid down will make farm poultry production far more profitable than it at present is, the author commends these pages to the thinking farmers, farmers' wives and farmers' children.

M. G. KAINS.

NEW YORK, October 1, 1910.

# Table of Contents

---

	Page
CHAPTER I.	
<b>THE MARKET FOR POULTRY</b> .....	1
Fresh eggs in great demand—Best market for early winter—Managing for eggs—The growth of the industry—Importance of good breed—Improved methods of hatching and rearing—Possible limit of the market—Farmers' attitude toward fowls.	
CHAPTER II.	
<b>BRANCHES OF THE POULTRY BUSINESS</b> .....	15
Eggs for home use—for market—for hatching—Guaranteeing hatches—Bad and good advertising—Day old chicks—Broilers—Roasters—Soft Roasters—Capons—Layers—Breeders for sale—Ducks—Geese—Turkeys—Guineas—Squabs—Systems of poultry raising.	
CHAPTER III.	
<b>LOCATION AND SITUATION</b> .....	45
Where to place houses, etc.—The soil factor—Convenience of water supply.	
CHAPTER IV.	
<b>POULTRY QUARTERS</b> .....	53
Styles of houses—Parts of the house—Model poultry house—Open front poultry house—Knock-down colony house.	
CHAPTER V.	
<b>POULTRY FIXTURES AND DEVICES</b> .....	66
Roosts—Dropping boards—Nests—Trap nests—Feeding vessels—Fountains—Grit and shell receptacles—Coops—Colony houses—Incubators and brooders—Bone and hay cutters—Grit crushers, Feed mixers and cookers—Prowler traps—Egg cabinet—Poultry gates—Shipping coops—Trap nest made from one board.	

	Page
CHAPTER VI.	
<b>BREEDING AND BREEDS</b> .....	77
What to select—Causes of failure—Utility breeding —Line breeding—Common mistakes in breeding Importance of constitutional vigor—Danger of in- creased productiveness—Value of vigorous parents —Experiments prove theory—Requisites of the trap nest—Kind of fowl to keep—Barred Plymouth Rock—Leghorn fowls—Light Brahma—Wyandotte —Rhode Island Red—Other breeds.	
CHAPTER VII.	
<b>FEEDING AND FEEDS</b> .....	112
Feed affects quantity of eggs—What hens put in eggs—Composition of poultry feeds—Nutritive ratio —Individual feeds—Importance of animal feeds— Green feed essential—Necessity for grit—Value of method—Grain ground or unground—Dry mash or wet mash—Value of skim milk—Feeding capons.	
CHAPTER VIII.	
<b>EGG PRODUCTION</b> .....	141
Hens total yearly production—Selecting layers— Laying ability improved—Management of laying stock—Spring and summer care—Autumn care of layers—Gentleness affects egg yield—Broodiness a natural characteristic—Record of 600 hens.	
CHAPTER IX.	
<b>INCUBATION</b> .....	159
Interior structure and development of egg—Why exercise care in handling—Shipping eggs for hatch- ing—Classes of incubators—Moisture essential— Methods of management—Testing the eggs—Care of incubators.	
CHAPTER X.	
<b>REARING</b> .....	175
Managing the brooder—Compare natural methods— How often to feed—Rearing chicks with hen— Chickens in hot weather—Care of little chicks	

## CHAPTER XI.

<b>MARKET METHODS</b> .....	189
Marking and shipping—Dressed poultry—Selecting stock for market—Killing and dressing—Packing for shipment—Cold storage poultry and eggs—Egg marketing methods—How to improve—Co-operative poultry associations—Honesty essential to success—Preservation of eggs—New York State experiments—Egg gathering.	

## CHAPTER XII.

<b>ESSENTIALS OF POULTRY FATTENING</b> .....	216
Desirable type of fowl—Feeds for fattening—Methods of killing.	

## CHAPTER XIII.

<b>HEALTH AND SANITATION</b> .....	221
Penalties for uncleanness—Disinfection—Remedies vs. preventives—Identifying diseases—Cholera—Diarrhea—Feather pulling—Roup—Pests—Mites—Lice—Worms.	

## CHAPTER XIV.

<b>WATER FOWL</b> .....	238
Ducks—Care of ducklings—Localities for duck yards—Cleanliness essential—Hatching in incubators—Selection of breeders—Breeds of ducks—Geese—Geese need pasturage—Profits in goose growing—Selecting breeders—Rearing goslings—Breeds of geese—Goose and duck feathers.	

## CHAPTER XV.

<b>TURKEYS</b> .....	264
Range essential—Temporary confinement—The laying season—Hatching—Rearing—Feeds—Profits in turkey raising—Varieties of turkeys.	

## List of Illustrations

	Page
Single Comb White Leghorn pullet.....	Frontispiece
Australia beats United States in egg production.....	8
Crate for chick shipping.....	25
Elevated water can.....	26
Compact house for small space.....	29
Coop for broodies.....	32
Barred Plymouth Rock hen.....	halftone insert
Light Brahma cock.....	halftone insert
Lice preventer.....	35
System of watering.....	46
Side hill poultry house.....	50
Water pail support.....	51
J. W. Griffin's poultry house.....	58
Fresh air poultry house.....	60
Ground plan of house.....	61
Knock down colony house.....	63, 64
Vermin-proof roost.....	67
Handy nests.....	68
Simple trap nest.....	69
Feed-saving hopper.....	70
Double brood coop.....	71
Trap for prowlers.....	72
Collapsible coop.....	73
Hen gate.....	74
Tredden trap nest.....	74
Board marked for trap nest.....	76
Breeding chart.....	83
Portable run for chicks.....	84
Poultry house elevation and ground plan.....	85
Ventilating door.....	86
Robust and inferior types of fowls.....	94
Double trap nest.....	100
Releasing trap nest.....	101
Frame and coop.....	101
Protected water pan.....	111
Raw material, egg machine and finished product.....	112
Stove pipe hopper.....	114
Hoppers reached from alley.....	120
Green feed free.....	123
Grit or shell hopper.....	125
Feed hopper.....	128
Ground plan of house and yard.....	129

	Page
Elevations of poultry house .....	129
Ventilated coop and detachable run .....	130
Weighted gate .....	130
Egg pail .....	141
Trap nest between pens .....	142
Trap nest door .....	143
Nest to cure egg eating .....	144
Double poultry house and run .....	149
Side hill poultry house .....	150
Feed coop .....	152
Self-closing gate .....	155
Egg-turning cabinet .....	161
Record card for incubator .....	168
Colony houses combined .....	171
Side hill coop .....	173
Nests and runs for broody hens .....	176
Chick block .....	178
Brooder on wheels .....	180
Chick marking .....	181
Triangular coop and yard .....	182
Portable coop and run .....	185
Portable colony house .....	187
Single comb Rhode Island Red cock and hen . . .	half-tone insert
Mammoth Bronze turkey cock .....	half-tone insert
Shipping coop .....	194
Latch for door or gate .....	197
Hen gate .....	199
Suspended roost .....	202
Cross-section of poultry house .....	206
Egg-turning tray .....	208
Protected coop .....	210
Portable coop .....	213
Portable coop and run .....	214
Shed for colony house .....	222
Combined scratching shed and house .....	223
White Chinese geese .....	half-tone insert
Pekin ducks resting in pasture .....	half-tone insert
Canvas-covered pullet shelter .....	226
Coop with detachable run .....	230
Fountain for chicks .....	233
Granary .....	235
Duck fountain .....	239
Celebrated Toulouse gander .....	251
Vehicle coop .....	257
Feed trough for turkeys and roosters .....	265
Sheltered water .....	267
Portable chicken coop .....	271
Grit, shell and charcoal hopper .....	272





## CHAPTER I

### **The Market for Poultry**

Opportunities to make money in poultry raising have never been better nor more numerous than today. Commission men and poultry specialists all over the country agree that high prices of grain have tended to reduce the number of fowls kept, more especially the poorer ones, since none but profitable fowls are worth keeping. They also say that the high prices of meat in the cities have produced an unprecedented demand for poultry and eggs thus encouraging the consumption of poultry and eggs because these have been more economical than beef, pork and lamb. This demand has also tended to reduce the size of poultry flocks and thus to widen the opportunities still more for poultry culture. In short, the outlook for raising poultry is exceptionally good. The greatest demands undoubtedly are for chickens and eggs. What the markets require are plump, young birds ranging from the broiler age up to yearlings. Just as voraciously they demand eggs that are really fresh, not called "fresh" so as to make them sell.

So far as poultry flesh is concerned, the breeds most in demand the country over are American. The two most favored are the Barred Plymouth Rock and the Rhode Island Red. These are preferred in New England, in the West and in the South, because their skins are of a popular color; viz., yellow, and their breasts are of good form. The Light Brahma is a popular market fowl in New

England because of its large size and also because of its brown-shelled eggs which are locally in greater demand than white-shelled ones. Other breeds are favored in many places, among them the Wyandotte and the Orpington, each in several varieties. There are also other varieties of the Plymouth Rock which are favored in some sections. But, take the country over, the Barred Plymouth Rock and the Rhode Island Red head the list as farm and market fowls of fairly good laying ability under ordinarily good management.

Everywhere, undersized, scrawny or otherwise poor poultry brings low prices, especially if as usually is the case it is not properly plucked and handled for market. Commission men in leading markets report that farmers in some sections are heeding their advice to replace mongrel flocks with American breeds, and annually now they are obtaining larger quantities of good poultry from such sections. But there is still unlimited opportunity to improve the general grades and unlimited demand for first-class stock. Poor poultry is so constantly discriminated against in the markets and the superior birds are so much more profitable that the mongrel is steadily being discarded as farmers become better informed and better poultry takes its place. Everywhere this is the trend.

### FRESH EGGS IN GREAT DEMAND

The egg market offers another illustration of abundant opportunities in poultry raising; whereas fowls properly managed will lay eggs fairly well when prices are high, poorly managed ones will not. During December, January and most of Feb-

ruary strictly first-class eggs often sell for 50 to 75 cents a dozen in large city markets and rarely below 25 cents in smaller markets. Even storage eggs of good quality rarely fall as low as 25 cents in the city markets during this period. The demand for fresh eggs is unlimited, but the market for poor grades is flooded at every season. There never has been a time when poultry raisers could do better than at present in egg production.

Inquiry among the New York commission men has revealed the following facts: New York city is short of high quality eggs and oversupplied with lower grades. This condition is neither new nor startling. It probably characterizes every season and every market and will continue to do so as long as eggs continue to be discovered, rather than gathered as a regular crop in judicious farm rotation. Slipshod methods in handling are responsible for the low grades and relatively low prices; careful management produces the high grades and the high prices. There is an unlimited demand for really first-class eggs, but labeling lower grades as first class does not raise either quality or price.

### **BEST MARKET IN EARLY WINTER**

At no time of year do commission men find it so hard to get an adequate supply of the best quality eggs as between November 1 and December 31. This is because farmers, as a rule, do not manage their poultry properly. Most of the supply of poultry and eggs in the general market, by the way, comes from the farms and not from the poultry plants—henneries so called. Well-managed henneries experience little difficulty in securing a

reasonable supply of eggs at this season and all the eggs they produce are sold at extreme prices without the slightest difficulty. Such methods are easy to apply in many districts. The only thing is that people have not thought them out.

Eggs which reach the New York market labeled "fresh gathered" are generally of very uneven quality, because shippers have forwarded stock just as collected from the farms. Much of this stock has been held in farm cellars or country stores, sometimes for weeks, in the hope of higher prices. It arrives in the market shrunken and so inferior that it is of slow sale even at low prices. For his own protection the city commission merchant grades very thoroughly. The system, or rather lack of system, in the country is to blame. When fowls are properly managed and eggs are sold as soon as possible after being laid, there are few complaints of poor quality on the part of buyers or low prices on the producer's part. Owing to annually increasing demand they have all stocks cleaned up before the advent of the spring egg freshet.

Only a small proportion of the eggs received are of "strictly fresh" quality. All such are snapped up immediately. This should prove a great encouragement to the producer. Most of the "freshly gathered" eggs come from the South; not many from the West. The Southern stock is very mixed. Henny eggs are in a class by themselves. They are white-shelled eggs in the New York market, brown-shelled in New England, produced on comparatively near-by farms. Always scarce and always superior because hurried to market, they command wholesale prices usually about 40 cents

during late fall and early midwinter. The final consumer has to pay 4 to 6 cents each for them, the usual late fall and winter price being 5 cents. Most of such stock is sold through private channels, and, therefore, does not figure in the general market. A common price during early winter, not only in New York, but in the large towns and small cities, is 60 cents a dozen for guaranteed fresh stock.

### MANAGING FOR EGGS

By judicious calculation as to the time of hatching and by proper management and feeding, hens may be brought into laying and kept at it better than they usually are when eggs command highest prices. By careful management of eggs laid when prices are low, a larger return can be secured from hens than from any other farm animal. It has recently been shown that 100 pounds of feed properly fed to well-bred, well-managed hens will produce 30 pounds of eggs. Leghorn and Minorca eggs often weigh two ounces or even more, but suppose the eggs in the 30 pounds weigh only one ounce each, there would be 480 or 40 dozen of them in the 30 pounds. These at the very low price of one cent each would bring \$4.80. How can 100 pounds of grain be sold in the raw state for that much money. Is it not evident that with grain even at recent prices the farmer can do better by feeding poultry and selling eggs than by disposing of the grain direct?

The neglect under which poultry has been raised has resulted in scarcity of eggs during the winter when prices are high and abundance in spring when they are low. Formerly hens were regarded

as a necessary nuisance, tolerated mainly because they lay the foundation of custards, cakes and other dainties, the enjoyment of which offsets somewhat the losses of grain and garden truck. This is still the case, even now, in many sections. Frequently eggs could be sold or bartered only with difficulty even at the minimum price of 6 cents a dozen. Though prices have risen, there is still complaint of low figures, but this is among those who do not manage their poultry well.

It is little wonder that poultry raising has had difficulty in shaking off the disrepute in which it was formerly held. The whole trouble has been in the mental attitude of the farmer. This has subjected the fowls to systematized neglect. Hens relegated to the stables, wagon sheds, fences or trees for roosting places; to the mow or the manger for nests; to the barnyard and field for feed, cannot do well. With starvation or butchery as alternatives and treated with such neglect what wonder that eggs are few and chickens that reach maturity fewer? This condition of affairs is happily being replaced by better management, because better management pays.

## GROWTH OF THE INDUSTRY

About 25 years ago estimates of the eggs and poultry production of the country were derided, but when the census published its reports these estimates were found to be very conservative. The new figures greatly exceeded the former estimates, even though census statistics were acknowledged to be imperfect. Between 1890 and 1900 the increase in egg production was about 58 per cent, the aver-

age rising from 38 to 65 eggs a hen. The money invested in the latter year was \$85,000,000, or an average of nearly \$17 a farm. These figures are now ten years old, but are the last available that can be considered fairly authentic. If one may judge by the increasing interest taken in poultry shows, in the sale of incubators, brooders and other supplies, and in the prosperity shown by the poultry press, the raising of poultry and the increased productivity of the average American flock will be found considerably greater when the next census figures are published.

Though the figures quoted seem large, they are nothing compared to what can easily be realized. This will be seen by comparing the average number of eggs each hen lays and the prices shown by the census report with figures obtained from other sources. The five states averaging highest in production in the last census were Maine with 101 eggs a hen; Massachusetts and New Hampshire with 96 each; Vermont with 92 and Connecticut with 88. In 33 states the average was below 72; in ten, below 60. The five lowest were Mississippi 42, Indian Territory 41, Georgia and South Carolina 40 each and Louisiana 39. The average prices in only seven states reached 18 cents or more a dozen, in 26 states they were below 12 cents, the lowest five states were Alabama, Oklahoma, Arkansas and Indian Territory, between 9 and 10 cents a dozen and Texas 8 cents.

While it is probable that in many of these low averaged states the highest average prices may not be reached, yet it is certain that in the neighborhood of large towns, especially in the East, the average can be considerably raised, because of the demand

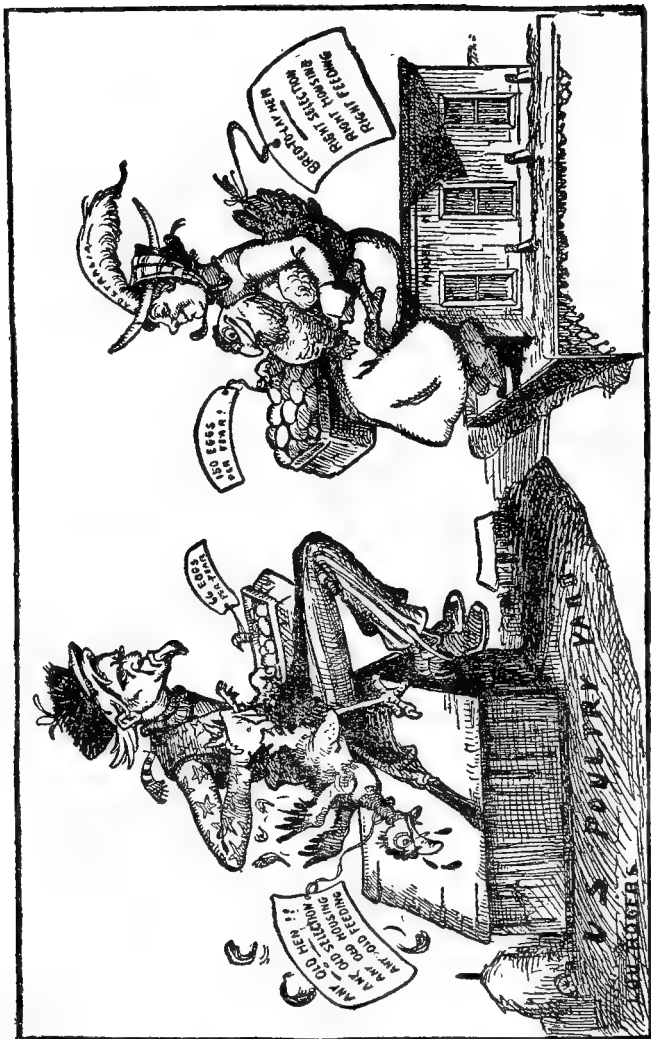

AUSTRALIA BEATS UNITED STATES IN EGG PRODUCTION



for new-laid eggs. As already noted, clean eggs, guaranteed fresh, are always in great demand and in private trade even higher than market prices can usually be secured. By proper breeding and management it is very easy to increase the number of eggs each hen will lay. If Maine can average 101, why not Louisiana? Proof that this can be done is frequent. Common sense, care in selection, feeding and management have produced whole flocks of hens which average more than 120 eggs a year. Flocks which average 150 or more are occasional and many individual hens, especially in Australia, where great interest in egg production is taken, have exceeded 200. Again, by judicious calculation as to the time of hatching, hens may be brought into laying when eggs command highest prices. This will be explained in a later chapter.

### IMPORTANCE OF GOOD BREED

Well-bred cattle, sheep and swine, are acknowledged superior to scrub stock by all progressive, thinking farmers and every argument that applies to such stock applies with even greater stress to pure-bred poultry, because the money invested can be made to yield returns in so much shorter time. No stock pays better nor even so well, dollar for dollar invested. Mongrel fowls, if cared for as even they should be, require as much time and labor as improved breeds, but almost invariably the returns from them, as generally managed, are less; and this quite apart from the sale of eggs for hatching or of fowls for breeding. To be sure, they are less costly to buy than pure-bred fowls. So are scrub pigs, sheep and cattle, but what thoughtful man deliberately buys them?

The cost of a well-bred animal, either bird or beast, looks large at first, but this is more than made up by the value such an animal has as a progenitor. In no line is this so noticeable as in the egg-laying strains of fowls which have become so popular within the last decade. By means of trap nests and other methods of selection, only those hens that have laid more than a certain minimum of eggs in a year are kept for breeding purposes. Their habit of egg production is confidently looked for in their chicks and those who breed and select them are usually successful. It is only necessary to think a little bit to see the advantage of keeping such stock and then only a little action in the right direction is necessary to enlarge the margin of profit on the balance sheet.

## IMPROVED METHODS OF HATCHING AND REARING

come next in importance to the keeping of pure-bred fowls and laying strains of hens. The incubator, as we know it, has been a practical machine in ordinary hands for only a little over 20 years. Now it is so simple that any one with common sense can run it. During the early eighties the number of incubator manufacturers could be counted on the fingers. Now about 100 firms put out machines and several of these sell more than 25,000 a year. Such increase, both in the number of firms and the individual outputs, are the strongest possible indications of the practicability of artificial incubation and the prominence and profitableness of poultry raising.

Should the farmer conclude his more profitable course would be to rear chicks for market rather than for egg production, he can readily acquire proficiency and an increased income. The business of raising poultry is highly profitable as a rule; far more profitable, pound for pound, than pork, lamb or beef; for chicks of good breed, such as Rhode Island Red, Plymouth Rock, Wyandotte, Orpington and Brahma, can be made to grow about a pound a month until four or five months old.

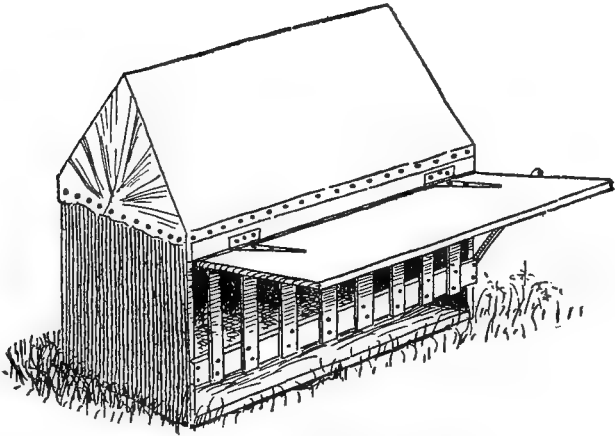

FLOORED CHICKEN COOP

The canvas top keeps this coop cool; the raised door provides shade.

When dressed they command, pound for pound, even in the local market, prices far higher than those secured for pork, beef or lamb and as the cost of production is less, the margin of profit is still wider.

## THE POSSIBLE LIMIT OF THE MARKET

can only be guessed at. A hint may be gathered from the growth of certain lines of business in which chickens take a leading part. In late summer enormous quantities of poultry are put in cold storage to supply the winter demand. Only the best grades are treated in this way. At the same time large quantities, usually of poorer quality, go to the great canning factories for making chicken soup and potted chicken. The large packing houses and other establishments have developed the poul-

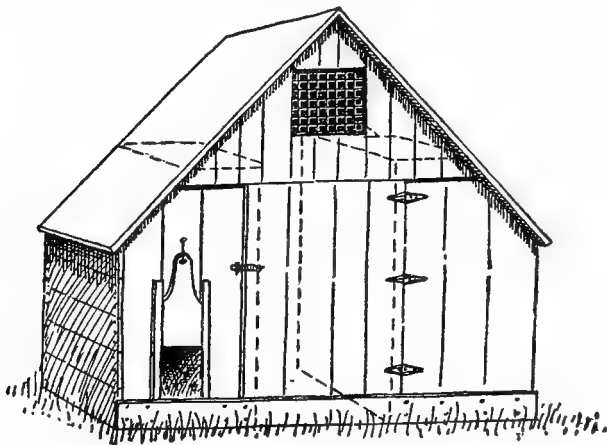

DOUBLE PIANO BOX HOUSE

Dotted lines show two piano boxes, backs and tops removed to make roof front and back. Cost for boxes, hardware, but not time, about \$5.

try-fattening branch of the business. Besides all these there is a steadily increasing demand for both live and fresh-dressed fowls.

So far as the general farmer is concerned, the poultry-fattening industry is probably the most important of these branches. If companies can afford to buy ill-bred, ill-fed farm fowls, pay freight upon them and feed them for several weeks so as to weigh a pound or two more, surely the farmer who does not have to pay city prices for his supplies of feed can do even better.

One of the strongest pleas for well-bred poultry is made by the men engaged in the fattening business. They declare that fowls of even moderate breeding are always more satisfactory to fatten than are mongrels, thus they emphasize what the farmer already knows concerning the fattening of sheep, shotes and steers. What wonder therefore, that in view of these facts progressive farmers are annually devoting increased attention to pure-bred poultry raising for commercial purposes.

## FARMERS' ATTITUDE TOWARD FOWLS

Where farmers think clearly, act promptly, keep well-bred fowls for a definite purpose and give them adequate attention, as reasonable attention as they give their other stock, they are proving that poultry is the most profitable branch of farm live stock they can keep when the amount, investment of time, value of feed, and other items are taken into consideration. In proof of this, it need only be mentioned that poultry farms and even poultry districts are springing up all over the country. Upon some of these farms tens of thousands of fowls are raised annually for market, or thousands of dozens of eggs produced yearly. In some districts, notably around Petaluma, Cal., where the White Leghorn is the

business hen, the output of eggs is several hundred carloads a year.

Every development in the poultry industry has had its origin in the clear thinking and right application of the thought of some pioneer individual. Without exception this man or woman has been jeered at as a crank, but later has had the sincere flattery of imitation paid to him or to her. Then the imitators have benefited and through them the community also.

To sum the matter up. The steadily increasing demand for the highest grades of eggs and poultry should encourage every one to raise better fowls. It should stimulate every one to adopt better methods of management so the market poultry will be well developed and well prepared for the markets, and so the pullets and hens will begin to lay by mid-October and thus catch the late fall and winter markets with a supply of fresh eggs. It should prompt every one to discard the bad method of allowing young poultry to shift for itself and the other bad method of holding eggs in ordinary farm cellars and country stores, thus lowering the quality and the price. It should suggest the advantages wherever possible of aiming either singly or in co-operation with neighbors to supply some special channel with the highest grade of well-developed, well-dressed poultry and new-laid eggs so as to catch the highest prices. There is unlimited demand for the best and unlimited opportunity to improve.

## CHAPTER II

### Branches of the Poultry Business

Only four kinds of poultry have been found widely profitable for market purposes; namely, chickens, ducks, geese and turkeys. The only other two kinds that occasionally come to market from the farm are pigeons and guinea fowls, but these in such relatively small numbers that they can scarcely be compared with the first four. The only way all these, except chickens and ducks, reach

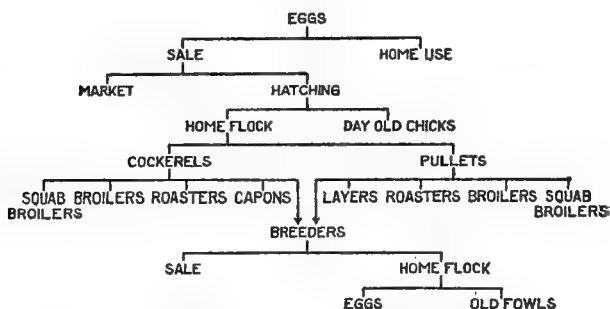

BRANCHES OF POULTRY RAISING

the market is in the live or the dressed form. Doubtless the eggs of all may be used on home tables. Duck eggs may also find a market in some localities, but there is in America no important demand for the eggs of any of them. Day old ducklings, goslings and turkeys may reach some special customer, but such instances are so rare as scarcely to deserve mention. All classes may, of course, find

ready sale either as eggs or as mature birds for breeding purposes. But when all is summed up the hen is the only fowl that can fill all the roles in the diagram on the preceding page. For this reason she will occupy chief attention in the pages that follow. Special chapters at the close of the book will discuss the other farm fowls.

The diagram covers the various activities of the chicken business. For convenience, let us start with the egg and discuss the various divisions.

### EGGS FOR HOME USE

The cost and the value of the eggs consumed at home is rarely considered by the general farmer. Hens are kept because the housewife must have eggs for making certain dishes as well as for boiling, poaching, frying, etc. If they were not kept the farmer would either have to do without or purchase eggs. As the former does not suit his palate nor the latter his pocketbook, he tolerates a few hens which care for themselves more or less, and which pick up a considerable amount of forage that would otherwise go to waste. If they supply the family's needs he is content to consider the yield in eggs and chickens as offsetting his losses of grain which he has to feed the flock.

This is a slipshod way of doing things. Its practice is only too often costly, especially when the common practice of allowing poultry to do its own breeding without any oversight is followed. No one who practices this way can tell whether his fowls are producing eggs at a loss or at a profit. Doubtless, with ordinary farm flocks, as still too frequently managed, the record of egg laying would



be more than offset by the cost of grain fed, to say nothing of the amount of food picked up, nor of the time and care the flock requires. In many such cases it would be even cheaper to buy eggs than to produce them. Of course, the other fellow might be losing, but that would be his lookout.

This matter of home consumption of eggs and poultry should be put on a business basis. Every pound of food fed to the flock should be charged against the flock, and every egg used by the family should be credited to the hens at current market prices. This is the only way the farmer can be fair to himself and to the hens and can know whether or not he should keep fowls to supply the home needs. Of course, when he aims to supply a market the eggs consumed at home should be credited to the flock so that the full value may appear.

## EGGS FOR MARKET

There is an unlimited demand for fresh-laid eggs. This has been shown in Chapter I. The market has never yet been fully supplied, nor is it likely to be for a very long time to come. The fact that some specially favored small towns may have all the fresh eggs they can consume, must not be thought to overthrow this statement. The great consuming centers are always in need of genuinely fresh eggs, and are likely to be even more clamorous in their demands as they learn how much superior such eggs are to those ordinarily procurable at grocery stores. On this account egg pro-

duction offers exceptional opportunities to make money. In fact, no branch of poultry raising is so likely to prove profitable over so wide an area. There is not the least likelihood that there will be an overproduction or that the business will be overdone; in fact, it is the only branch of poultry raising concerning which this statement can be made without qualification.

Perhaps the most important reason why egg production and sale can be made most profitable is not so much on account of great demand and high prices as because the cost of production is proportionately less than in other branches of the chicken business. By "cost of production" is meant not only the cost of the egg as a market commodity, but the cost of making the machine, the hen, which is to manufacture the egg. In rearing chickens to sell as broilers and roasters the cost occurs mainly in the losses of chicks during the brooding period. Pullets of a reasonably good laying strain of any good breed having been reared to laying age are, therefore, worth far more because of their ability to lay than they would be if sold for eating. In fact, to be disposed of in this way would generally mean a decided loss. For the eggs such pullets would lay, especially if hatched early enough to begin laying during October or early November, would be worth several times the market price that they could command at that season. It is all well enough to sell hens after they have done laying. Indeed, their carcasses at that time may command even higher prices than in the fall. So the return from the eggs they lay is so much to the good, the only items of expense to be deducted being those connected with housing, feeding and

care—the maintenance of the machine, the hen, the cost of the raw material, the feed and the items of labor, interest on investment, etc.

## EGGS FOR HATCHING

One of the advantages of keeping pure-bred fowls is that eggs may be sold for hatching at prices considerably higher than even the highest market figures. No farmer, however, should strive to make sales, especially through advertising, until after he has learned to breed and select his flock sufficiently well to secure fair uniformity in the progeny. This applies just as much to one line of breeding as another, whether for plumage, for flesh or for eggs. Having reached a fair degree of success it will be time enough to dispose of eggs to his neighbors, and by means of advertising. In fact it would be unwise for a successful poultryman not to dispose of his surplus eggs in this way provided, of course, he can do so at reasonable profit. The one thing to remember is always to have a good article to sell and to treat the customer with as great fairness as one would demand were the case reversed. This is the surest way to build up a good-paying business.

It must be remembered that selling eggs for hatching is in the main not so satisfactory to either buyer or seller as selling fowls, or perhaps even as selling day old chicks. To be sure the great majority of poultry breeders do sell eggs for hatching. Perhaps this is because the custom has become almost universal or because it pays. In spite of the disadvantages it seems evident that selling

eggs has enough to recommend it to offset these drawbacks. One thing the poultryman should remember is not to make his price too small. When he has really good stock, he is, if anything, more likely to sell eggs at, say \$2, than \$1.50 or \$1 a setting. One of the principal advantages of selling at this higher figure is that a better class of customers is secured, a class more desirable to deal with because of their familiarity with the risks to be run in buying eggs. Such people are more reasonable in their demands, more careful in their methods of manipulation of eggs and more considerate of the breeder when the hatches are not as satisfactory as they might be.

When several settings are ordered at a time, it is customary to make a reduction from the single setting price, because the work of selling, handling, packing, etc., costs relatively less for several settings than for one. It is also customary to reduce the price of settings toward the close of the season so as to induce people who would not buy when prices are high. Late sales are considered also as encouraging sales in later years, because the customer sees the value of the improved strain and is willing to pay the advanced price so as to get the advantage of early hatching. On the other hand many breeders maintain a uniform price throughout the season because they believe that in the long run not only their interests but those of their customers are best served in this way. Late hatched chicks, especially from stock more or less weary from laying, are not, in their opinion, as desirable as chicks hatched earlier, nor does the breed or variety live up so well to its reputation.

Whether the breeder can guarantee eggs or not is a disputed question. About the only things which the seller should guarantee are that the eggs are true to name and laid by the fowls which the purchaser has seen advertised. The eggs should be the same as the breeder would set to increase his own flock. They should be carefully packed and handed to the express company in first-class order. Breeders often agree to replace eggs which have failed to hatch either at a reduced price or at no cost. The principal facts to be taken into consideration so as to arrive at a fair judgment of any case, are the results secured from similar eggs at home and the reports of customers in general. If these are not satisfactory, the breeder should do his best to satisfy his customers. Indeed, it would be to his own interest to do this, but he should strive to find out why the hatches are poor and rectify the defects, if possible. If he cannot make things right he should, for his own best interest, as well as that of his customers, decline to fill orders for stated reasons. This question will be discussed in the chapter on breeding. When hatches run from seven to ten chicks to a setting, the breeder may be considered to have done well by his customers and he should be under no further obligation, because so much depends upon factors beyond his control.

### **GUARANTEEING HATCHES**

When a breeder has sufficient stock to warrant his advertising, his advertisements should begin to appear preferably during January and certainly not later than February. This is not to fill, but to list orders, because high-priced eggs should not be

shipped during inclement weather since there is great danger of their being chilled in transit and because results at that season are much more problematical than when the breeding season is at its height. The object of early advertising is to encourage inquiries and book orders for delivery during March, April and May. As to what and how to advertise, the following paragraphs will be found helpful.

### GOOD AND BAD ADVERTISING

A study of poultry advertisements in any poultry or farm paper will bring out many points which will interest advertisers of poultry. One of the commonest errors is to contract the names of fowls. The evident thought is that the advertiser will save some money by so doing. Usually he will not, the rate being the same whether for an initial or for a whole word. This false economy cannot help but prevent the advertiser from getting orders.

For instance, the man who advertises "B. Leghorns" does not tell whether he has Buff, Black or Brown Leghorns, and the prospective purchaser in haste to secure eggs or stock would most likely pass over such an advertisement, and correspond with the man who spells out the word. The advertiser should always put in the style of comb for the same reasons. Another objection to using initials is that every spring there are people just entering the poultry business who don't know what these initials stand for, and they will be influenced by the directness and plainness of an advertiser's words. It always pays to be definite.

One of the worst features of advertising where contractions are used is that the advertiser is almost

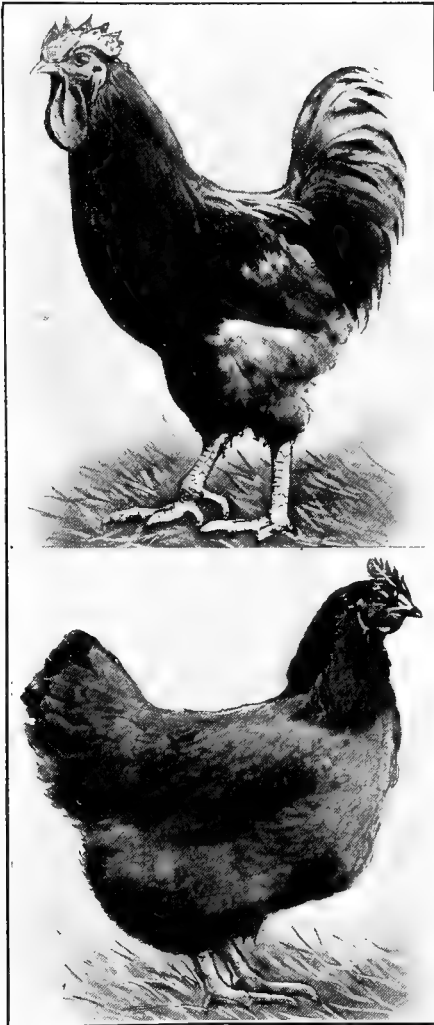

SINGLE COMB RHODE ISLAND RED  
COCK AND HEN



MAMMOTH BRONZE TURKEY COCK



sure to conclude that the paper in which he advertises is not as good a medium for selling stock as it really is; whereas, the trouble arises in his indefinite wording or use of initials.

Nothing but what will interest the purchaser should be included in an advertisement. The great majority of readers of farm papers are interested more in business poultry than show birds and, therefore, are not attracted nearly so much by statements that the birds are prize winners, as they are by the fact that the fowls are good layers or of heavy weight. The buyer is looking for good stock or eggs, and naturally concludes that advertisers sell such. If scores, pedigrees and show records are desired they can be learned through correspondence, since most readers are interested from the market standpoint and people who seek such fowls are much slower in deciding to buy than farm readers generally are, and do not look for these items. Of course, with fancy fowls advertised in poultry papers the case would be different.

Another common error which tends to reduce advertisers' sales is the practice of mentioning some other man's strain. The prospective purchaser is almost sure to conclude that the advertisers' stock is not as good as that of the man whose strain he advertises, and will make effort to discover the address of the man whose strain is mentioned. When a poultry raiser buys fowls from a well-known breeder he does so to improve his own strain, and from the moment the birds enter his yards they become a part of his manufactory, and help to turn out his improved product. He, therefore, should advertise his stock as his own, and not as that of another man.

The following sample advertisements are characteristic. They are taken from a farm paper and will serve as samples of good and bad advertising:

"Eggs that hatch big, strong chicks from my prize-winning Barred Rocks. \$1.50."

"Single Comb White Leghorns, 23 years, 5-pound hens, large eggs. Best for everybody. Only kind kept. Eggs, \$1 for 13. Electrics pass farm. Write, telephone."

"Reds, Rocks, Wyandottes, Leghorns, eggs \$1 a sitting."

"For sale. Little chicks, P. Rocks, R. I. Reds and Leghorns."

In each of the first two there are directness and definiteness which attracts the buyer at once, and in the latter of these two the advertiser shows that he is a progressive man living in a thriving community, for he can be reached by phone and by trolley. Moreover, he must have good stock, for he has specialized for 23 years, now keeps no other variety of fowl and has brought up the weight of his hens to 5 pounds and increased the size of the eggs. In the second two the faults are very apparent. The prospective purchaser cannot tell whether the man who has "Reds" has Buckeye Red or Rhode Island Red fowls, nor what variety of "Rocks," etc., he has. The same is true of the second, where no price is mentioned. If you, reader, were looking over such advertisements which would you choose?

## DAY OLD CHICKS

During the past few years the shipment of day old chicks has grown greatly in popularity. Much that has already been said concerning the sale of eggs for hatching applies to this branch of poultry raising—all that relates to quality of stock, advertising, etc. Next in importance to good stock is ability to secure large hatches of strong chicks

in incubators at times when customers are in need. Until the poultry raiser has become proficient in artificial hatching he should not attempt to branch out in this line, nor should he begin to advertise widely until he can care for a considerable volume of business. The development of a local business will usually pay well enough and with less risk and expense than an advertised business of this kind. Where he has worked up a good utility strain of fowls he can thus probably do much better himself as well as be of far greater help to his neighborhood.

The wide increase in numbers of a specially good strain of utility fowls that are doing well for him should be a source of greatly increased income to any locality. Far from working against the owner, as

some may suppose, such a development should help. It might easily be the foundation of a special trade for the district in dressed poultry or eggs, or both, a trade that could command higher prices in the market.

The monetary advantages of selling day old chicks, only the man who does the hatching can decide. Some of the items he should consider are the original cost of the eggs, the price at which he could sell these for hatching, the percentage of chicks he can reasonably count on, the cost of hatching the individual chick, and the reasonable amount he should add to the producing price to give him a

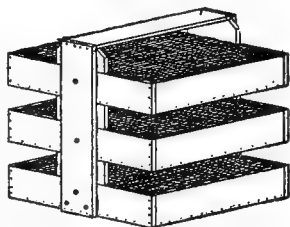

CRATE FOR CHICK SHIPPING

Each tray in four partitions. Burlap lined and surrounded when in use.

fair return after deducting the cost of advertising, correspondence, packages, etc. Some men can sell at even less than 10 cents a chick, others charge 15 cents or more. Much should depend upon the character of the strain of fowls, a really superior strain of egg producers selling for higher prices than chicks of ordinary caliber. It seems customary to charge two and one-half times the price of the egg used for hatching, since it is not safe to figure on more than one chick for every two incubated. This leaves only a small margin of profit.

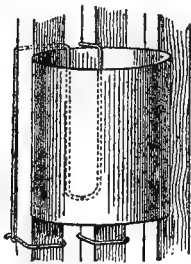

ELEVATED WATER  
CAN

Wire spring holds  
can in place.

From the buyer's standpoint the plan has much to commend it. This is the only method whereby the buyer can count his chickens before they are hatched. If the shipper understands his business as he should the chicks should reach their destination even a thousand miles away in first-class shape. A distinct advantage claimed for the method is that express employees are far more careful of chicks than of eggs for hatching. As to the chicks themselves, they seem to stand the journey better than if even only a few days older. This is because they have not yet digested the yolk which seems to be Nature's provision for the early days of chick infancy.

The hatching egg business, in a great many instances, has been unsatisfactory to the seller as well as to the buyer. With the introduction of this somewhat novel branch of the ever-increasing poul-

try industry, many of the objectionable features of the hatching egg business are removed. The purchaser can know he is investing in realities, whereas, when he purchases hatching eggs he is buying prospects. This branch of the poultry business has, therefore, come to stay and present indications are that it will become more popular as its advantages become better known.

### BROILERS

As a general proposition, no one should plan to go into the broiler business. This branch of poultry raising, as a branch, is not profitable; but where broilers are looked upon as a by-product of the egg farm, or the general poultry business, they should be profitable when sold early enough; that is, before they have "eaten their heads off."

By the term "broiler business" is meant the hatching of February-laid eggs to supply a demand for chickens in May when prices are high. This is costly, first, because the eggs which are scarce at that season command high prices; second, because the number of chicks that can be counted upon to live does not generally average more than 25 per cent; and, third, because young cockerels from the farms can be so easily held over in cold storage from the previous summer. These come in competition with the winter-raised broilers, and people will buy them in preference because of their low prices, the difference in quality not being enough in general estimation to warrant the higher figures. It has been estimated that more than 90 per cent of the chickens sold as broilers come from poultry produced either on egg farms, fancy yards or gen-

eral farms where they are a by-product and must be gotten rid of quickly to prevent loss.

Cockerels may pay more than the cost of feeding, but unless they can have free range they are not likely to pay the whole cost of their production, counting the value of the eggs, the cost of hatching, the labor and the feed, etc., up to the time of their being marketed. Unless the poultryman has facilities for fattening and thus disposing of his cockerels as roasters or capons, it would be more economical to sell the broilers as soon as they are of marketable size.

## ROASTERS

What is known in the market as a roaster is a fairly matured fowl large enough, either alone or with another roaster, to supply a family dinner. Such fowls are sold when four or five months old, depending somewhat on the breed. The popular American breeds go to market at the earlier age; the Asiatics at the later. These fowls are most profitably raised by being allowed free range of the stubble fields, pastures, meadows, orchards, etc., where they pick up a large share of their living between the time that they can leave the brooder or the mother hen and the time they are sold. Frequently they are fattened for two weeks or so before going to market so as to add a pound or more to their weight. They can be considered more profitable, as a rule, than broilers raised in the ordinary way on the farm; and generally it is better to allow the cockerels to have the run of the fields and orchards where this can be conveniently arranged. The pullets should be kept by them-

selves since their role is to be egg producers. If cockerels must be fed in limited yards, they will usually not pay very well as roasters because of the cost of feeding and care.

Hens that are not to be kept for laying the following fall and winter or with old roosters to be kept for breeding, should be disposed of as soon as possible after their season of usefulness has closed. They may often be profitably fattened for

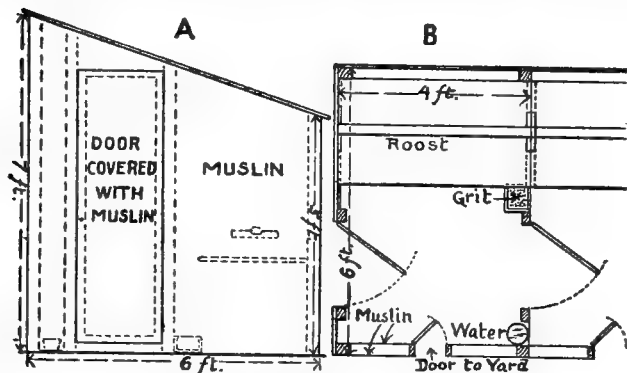

COMPACT HOUSE FOR SMALL SPACE

a couple of weeks prior to sending to market, but should always be sold for what they are; namely, old fowls. Their chief use is for fricassee and soup. The packing houses take large quantities for these purposes and small markets also use a great many where there is a good home demand.

### SOFT ROASTERS

Along the south shore of Boston Bay has grown up a very profitable branch of poultry raising for

the Boston market. The fowls are marketed in spring and early summer when they have reached the heaviest weights and before their flesh hardens. They command prices ranging as high as 30 cents a pound, but the bulk of the stock is marketed at about 25 cents. The district has a present output of 75,000 to 100,000 roasters annually. This industry, while it employs much the same equipment that the special broiler business requires, is, in the main, more successful and profitable than broiler raising. It is the only line in which pullets have been used for market instead of for producing eggs.

In the production of these roasters, the incubators are started in early autumn and kept busy until spring. The chicks are kept in brooder houses until past the critical age, when they are moved to colony houses and fed from hoppers. They also have more or less green feed, beef scrap, etc. The cockerels are generally caponized but not marketed as capons. The early hatches are generally of Light Brahma fowls; later ones are of Plymouth Rock. It is the opinion of dealers and growers that the Brahma has been decreasing in size until the fowls no longer average larger than the Plymouth Rock, which is a better layer and matures quicker, the White variety of which is even more popular than the Barred.

Many of the growers buy their eggs of farmers and cottagers who make a business of producing these eggs for hatching. The ruling price is 50 cents a dozen. As the medium sized Light Brahma cockerels are more active and vigorous and the medium-sized hens are better layers, the size has not been kept up by the breeders. The roaster growers are, therefore, confronted with a necessity



of keeping their own laying stock or largely giving up the Brahma. Few Wyandotte or Rhode Island Red fowls are used. The former weigh fully a pound less than the Plymouth Rock and lay smaller eggs. The Rhode Island Red is not liked because, after the chicks pass the broiler age, they quickly become narrow breasted and the flesh is not of as good quality as that of the White Plymouth Rock. This last breed will lay more eggs than any other suitable for the purpose and will produce the best color and quality of meat.

The young chicks are fed five times a day at first, but soon get only three meals. The brooder house floor is covered with an inch of sand. Second growth hay is cut into short lengths and a basketful strewn through the pens each day. The feeder goes through the house with a pail of chick feed and throws a small scoopful or two in the litter. He then gives a mixture of dry ground grains, consisting of two parts wheat bran and one part corn meal by measure, after which the chicks get a good feed of beef scrap. Enough feed is given so that while they have food constantly before them, they will eat it up clean once a day at least.

Generally speaking, the return from these roasters is from two to five times as much a head as from broilers. The main difference in cost of production lies in the feed. Roasters which would sell at the maximum price, 30 cents, should cost 10 cents a pound above the cost of raising them to broiler age. Thus an 8-pound roaster would cost 30 cents up to broiler age and 80 cents to market size, or \$1.10. It would sell at the above price for \$2.40, so there would be \$1.30 margin.

Among the principal advantages of this branch

of poultry raising, are the extended period of incubation and brooding, which permits the expense for eggs to be distributed over a longer season. Thus a grower may have five to eight hatches between October 1 and April 15. He will thus require a much smaller number of incubators to hatch out a flock of profitable size than if he were raising

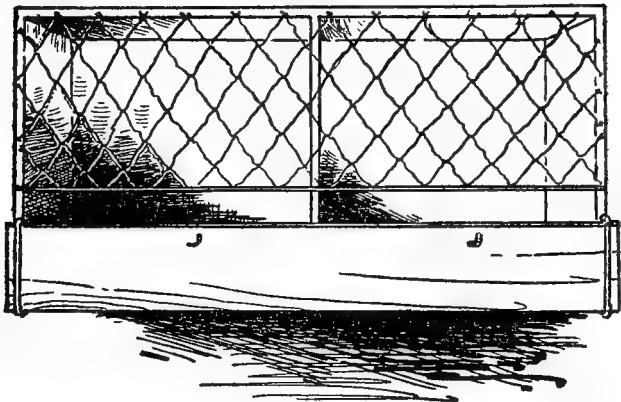

COOP FOR BROODIES

Slatted bottom and fresh air dampen broody ardor. Pegs in front for feed pan.

broilers during the winter. He can also keep sufficient hens to supply his own machines, a thing he cannot do were he raising broilers, unless he employed an unprofitable amount of assistance.

Whether this system will pay in other sections of the country cannot be stated positively, but in all probability where there is a large market such as New York, Philadelphia or Chicago, there should be good opportunities in this direction. The business as managed in Massachusetts is in a certain

sense co-operative, for though the market is controlled by only a few dealers, the brand commands the highest price paid for chicken flesh and every fowl raised can easily be disposed of. Nowhere else in this country is there so good an example of co-operative poultry flesh production. The industry is not likely to prove profitable in a small way among farmers who have not a specially good market close at hand and who cannot raise sufficient numbers to make a strong impression upon that market. Still, where a man has suitable environment, it might be worth while to take this branch experimentally and enlarge as experience indicated was wise.

## CAPONS

The practice of caponizing is steadily growing in favor in the United States, especially in the Eastern and middle Northwestern states. In the Eastern markets, capons are quoted from December to May at prices ranging from 20 to 30 cents a pound. The larger the bird, the higher the price, as a rule.

As to whether the practice is profitable or not, the individual poultry raiser must decide. Doubtless it is most profitable where grain is cheap. On this account, it is more popular among farmers than among specialist poultry raisers, because the poultry raiser is obliged to buy most of his feed and cannot profitably keep large numbers of fowls which are not paying the running expenses of their keep with a more or less constant income. Such men find it more profitable to direct their energies toward egg production.

On the other hand, the farmer who cannot handle

large numbers of early chicks can dispose of surplus cockerels as capons better than as broilers or ordinary roasters. The feed required is with him a much smaller matter than with the poultryman, because a large quantity can be picked up by the fowls themselves and even the grain which he would otherwise sell can be disposed of as poultry flesh at a higher figure than as grain. Such being the case, cockerels which at 5 to 6 pounds would sell for \$3 to \$5 a dozen can be caponized, made to weigh 10 to 12 pounds and sold at much higher prices. They should thus net the grower from 10 to 16 cents a pound or about half the Eastern market prices; figures that would mean high value for the feed consumed as well as paying liberally for the work. There need be no fear that the market will be oversupplied because the demand for well-grown, well-dressed capons is annually increasing.

The object of caponizing is not primarily to increase the size of the fowl, but to heighten the quality of the flesh. Since capons do not quarrel or worry one another, they can be kept in large flocks with assurance that they will fatten easily and more economically than other classes of fowls.

Only the large breeds are suitable for caponizing; small capons, while salable, do not command highest prices. For this reason, the Mediterranean and most of the other European breeds are not suitable for caponizing, though, perhaps, the Faverolle, the Orpington and the Dorking may be large enough, if well bred for size. These varieties, however, are not very widely popular in America. Unquestionably, the American and the Asiatic breeds lead in their value for caponizing. Well-bred Light Brahma cockerels, with proper attention and enough

time, will usually make the finest as well as the largest capons; but the Cochin, the Langshan and the Indian Game are also good. All of the Plymouth Rock and Wyandotte varieties may also be used, since they are large enough to make good-sized carcasses.

## LAYERS

The production of layers is unquestionably the most important branch of the poultry business. This is shown by the fact that egg farmers would be glad to pay higher prices for pullets than they can sell their cockerels for when of broiler size. Pullets, as a rule, cannot be expected to lay before four months old among the Mediterranean breeds, five months among the American, and six months among the Asiatic. On this account for egg-laying purposes they should be hatched early enough in the spring to commence laying during October. If hatched too early they are almost sure to molt before very cold weather comes and not to resume laying before February or March, thus cutting them out of profitable egg production.

Since the first four to six months is the most costly time in a hen's life, there should be a considerable period of egg laying to balance up this expense. On this account hens that have produced well should be kept over for another year; at least until the following winter when the pullets are laying well. By proper management hens may be kept



LICE PREVENTER

Cup under roost  
filled with oil on  
stout fence wire  
support.

in, or brought back to laying during the summer and fall, except, perhaps, during the molt, and even during this period some eggs may be expected. These remarks apply more particularly to the Leghorn and Minorca varieties which are pre-eminently the laying breeds. The fleshier breeds, such as Plymouth Rock, Wyandotte and Rhode Island Red are less likely to be profitable as layers the second season unless they have been specially bred and selected for laying. The Plymouth Rock especially is apt to become too fat to lay well after the first year. On this account the general opinion is held that fowls for ordinary egg production should not be kept more than one year. Of course, for breeding purposes, this should not be considered.

### BREEDERS FOR SALE

Every raiser of poultry for whatever market purpose should keep only pure-bred fowls. These should always be selected and bred with great care, so as to get the highest possible efficiency in each bird and in the flock as a whole. The man who follows this plan is sure to have a valuable strain of fowls for sale, a strain that should command high prices, whether sold as eggs for hatching, as day-old chicks, or as full-grown birds for breeding purposes. Whether it would be to his advantage to strive for the points that breeders of fancy or standard-bred fowls emphasize so much, is a matter which he alone can decide.

It may be taken, as a general rule, that to start in poultry keeping with the object of making money from fancy poultry is an unwise thing. There are so many hundreds of people already in that busi-

ness and there is so little profitable sale until the breeder has made himself more or less conspicuous, either by winning prizes at fairs and poultry shows or by advertising, that it is much wiser to follow one or more of the market poultry lines where the demand is constant, and to select breeding stock of standard requirements as a side line. Unquestionably there is plenty of money to be made in raising fancy poultry, but there is better opportunity for the beginner, within reasonable time, in the market branches. Whoever goes into poultry raising for profit will find it to his best interest to begin with market stock, to breed and select toward a high ideal of production and let the combination of fancy poultry for exhibition, etc., follow as a postscript, if it follow at all.

## DUCKS

As a general thing it will not pay the ordinary farmer to go into duck raising on an extensive scale. If his local market, however, is not oversupplied he may raise from a few score to a few hundred, provided his place is adapted to raising ducks. But duck farming, as a branch, is a business for the specialist, and unless carried on very extensively, is not likely to prove profitable. To be sure, there are numerous duck farmers who are making money, but the margin of profit in green ducks, that is, ducks sold at about ten weeks old, is very small. The business demands skilled labor in feeding and dressing. Ducks not economically fed cannot be profitable, nor can poorly dressed ones be sold to advantage. These two facts make the duck business particularly advantageous to the specialist and disadvantageous to the general farmer.

Only one breed of ducks, the Pekin, is popularly grown for American markets. In England the Aylesbury is more in demand. Duck eggs are in small demand in some markets, and there is also a market for breeding stock, but these demands are insignificant in comparison with those for chickens. If one has suitable environment and good local markets for ducks, it may be worth while to take up this branch of poultry raising experimentally on a small scale and develop it as experience is gained. The demand for good ducks, when such are produced, is likely to increase in the local markets, and the grower may find it profitable to enlarge even considerably.

In big duck-growing establishments the cost of raising is estimated at 7 to 10 cents a pound. Here, practically all the feed is purchased, as a rule. The profits range from 10 to 25 cents a duck, depending largely upon the time of year the birds are sold. In order to be profitable, therefore, a farm should produce not less than 10,000 ducks. Such farms can be developed only after several years of conservative growth, because though the duck is amenable to machine methods of management, the grower must become acquainted with the business and in a sense grow with it. If this way of development is followed the margin of profit should increase as the volume increases, because when managed on a small scale the cost is usually greater and the margin of profit smaller. Where chickens and ducks can be grown on the same place upon a less extensive scale, the ducks will generally be found to pay better than the chickens, provided the demands of the local market are not exceeded. This applies especially to private trade.



## GEESE

require considerable room to be made profitable. They cannot be economically raised in confinement. Where farms have waste, marshy lands or meadows that do not pay taxes, such lands can frequently be made profitable by means of geese. The birds will practically feed themselves most of the year. All the breeding flock needs is a dry place to sleep and moderate feeding in winter. Geese are not raised in America in large flocks. They are pre-eminently farmers' fowls. Many more could be kept profitably than are now raised. The supply does not equal the demand. It would not be profitable, however, to attempt goose raising without the adjunct pasture; the cost of feeding would be too great. Therefore, unless pasture can be had, geese should be left alone.

The cost of raising market geese is variously fixed at 7 to 10 cents a pound when much feeding is necessary; but on pasture these figures can usually be cut in half. Goslings sell at five to six weeks for fattening in New England for \$1 to \$1.20, but such prices are by no means general throughout the country.

A special industry has its center in Watertown, Wis., where geese are fed noodles by hand at two-hour intervals. These geese are raised in the usual way until they attain ordinary market weights, when the special feeding begins. They are sold mainly to the Jewish trade at prices in the final market the same as their weights; that is, a 20-pound goose will sell at 20 cents a pound, a 25-pound goose at 25 cents. Often these geese will sell for \$5 to \$10. This branch of goose growing,

however, would be a good one to avoid unless the would-be grower can learn the methods in vogue by actual contact.

## TURKEYS

The turkey presents a case exactly opposite to that of the duck; it has not yet been raised in a commercial way. For farm conditions, however, it is better adapted than the duck, because of its ability to shift very largely for itself and to convert into profitable flesh large quantities of food that would otherwise go to waste. Turkeys have been and still are grown in limited areas, but always in small numbers. They do best where there is unrestricted range. The great demand for turkeys and the best prices come between the middle of November and the middle of January, a time which suits farmers best.

Another point that favors farm turkey raising is that hatching can be done at the natural season, so that the poults will grow to salable size in time to reach the markets already mentioned. Nothing perhaps argues so strongly in favor of turkeys for the farmer than these two facts. Another thing that favors turkeys for the farm is that farmers' wives and daughters usually take kindly to this branch of poultry raising, even more than to chickens, ducks or geese. Probably this is because of the extra money that the turkeys seem to bring. It is questionable whether they actually do yield larger actual net returns than chickens raised either for meat or egg production. But the money seems to be mostly profit, especially as a larger sum is brought in by the sale of individual turkeys than by that of individual chickens.

Another point in its favor is that turkey production does not interfere with other poultry work, because the turkeys get along well with the chickens and because they cover a wider field in their foraging. In general, therefore, it is highly desirable that every farmer's wife should keep a flock of turkeys in order to utilize waste food profitably.

### GUINEAS

Since it has been discovered that the guinea fowl has a game flavor and can be sold as various kinds of more valuable flesh, it has been used in the large city restaurants as a substitute for various kinds of game as well as being sold under its own name. This fact has encouraged the growing of guinea fowls to supply the demand. Broiler size guinea fowls are often sold as quail on toast and larger ones for prairie chickens, pheasant or grouse, and prices for these have run very high, often at retail \$1 to \$2 a pair being paid. Like the turkey the guinea fowl thrives best where there is ample free range, and unless one is sure of securing at least 50 cents each, the guinea had best not be raised with the market in view. The reason for this is that guineas are probably even more exacting in their demands than turkeys, but where one has the range and is sure of a good market it may be well to make a venture in this direction.

### SQUABS

Much has been written concerning the production of pigeon squabs in recent years and doubtless many people have been induced to go into the industry. It must be said, however, that while there

are successes in this line of poultry production, yet the demand is practically met by the present supply and the price is about fixed, so that it is not advisable for the farmer to go into this branch of poultry raising. The business, like the raising of green ducks, is a specialist's line, and not adapted for ordinary farm conditions. There is no reason, however, why a home supply of squabs should not be raised. The pigeons are easily kept and will afford a table delicacy at small cost.

### SYSTEMS OF POULTRY RAISING

At frequent intervals, so-called systems of poultry raising are advertised in magazines and weekly periodicals, circulated widely not only among poultrymen, but especially among people not posted in poultry production. The usual design of such advertisements is to sell some so-called secret or a book said to give directions for making more money out of poultry than by the ordinary methods. As a rule, those who answer such advertisements are disappointed with the information they receive. There is nothing specially new about the feeding of sprouted grain, and there is no reason why the practice of feeding such material should be called a secret and sold as such; yet this has been done. There are probably no better ways of preserving eggs than by the water-glass method and the lime-salt mixture, yet almost annually some one advertises to sell a secret recipe which usually turns out to be one or other of these two.

Where a really meritorious system has been worked out, it usually reaches the public in a legitimate way and through natural channels. The

experiment stations and agricultural colleges have done a great work in testing many so-called systems and even in originating others. No poultry raiser should send money for advertised secret systems until learning through one of the experiment stations whether such a system is feasible or not. Of course, these remarks are not leveled at anything legitimate in the way of a system. For instance, the application of the principles of breeding to improved egg production, etc., emphasized in this book are partly the result of investigation by the late Prof. G. M. Gowell of the Maine experiment station. Professor Gowell published the following statement in a booklet which he sent to inquirers:

"For more than 25 years I have bred Barred Plymouth Rocks for producing good brown eggs, by selections from the general stock. While that system of selection gave birds that laid eggs of good size, shape and color, there was no means of knowing whether the eggs incubated came from the hens that were good or poor layers, and it was reasonable to suppose that as many chickens came from mothers which had laid poorly through the winter as from those that had laid well. Indeed, recent investigations have convinced me that the eggs from hens that have only just gotten well under way laying at the commencement of the incubating season, yield more chicks than do those from hens that have been laying well since early fall.

"Thoroughly believing in the principle of breeding performers to performers to get performers, I determined to cull out rigidly all non-performing hens and breed only the good layers to the sons of all good layers to get good layers. In order to do this, in 1898 I devised and constructed at the Maine experiment station 52 trap nests and commenced selection of the best laying hens for foundation stock.

"At the end of the year all birds that had not laid 160 eggs were rejected, and those that had laid above that number were retained for breeding. They were bred to sons of hens that had laid 200 or more eggs in a year."

This system practiced by Professor Gowell has been widely adopted by the more progressive poultrymen and has given excellent results. With various modifications it has been followed by a prominent firm of egg producers who have published a book giving figures, drawings, half-tone illustrations and descriptions of their poultry plant and its

proWess. The essential features of this so-called Corning system are embraced in the present volume. The system, as has been said, has proved highly satisfactory with a large number of poultrymen, and while the figure of nearly \$6.50 annual earnings for a hen may seem exceedingly high to poultry raisers, especially in the Western states, yet where a poultry yard is so favorably situated with respect to market as that of the Corning's, and where the eggs produced by hens specially selected, according to the Gowell method are managed in a rational way and the eggs sold at an annual average of nearly 50 cents a dozen, it may be readily seen that money returns would probably be exceedingly high. This is the very point that the present volume seeks to emphasize; namely, that good breeding, good management and business marketing will enable the poultry raiser to make far more money out of his poultry than by keeping scrub hens in a haphazard way and marketing in slipshod manner.

Another very widely advertised system has been prominently before the poultry world for the last few years. Its object is to raise a far larger number of fowls on a given space than has been possible by any other system. The plan is to keep the chicks in confinement and force their precocious development, especially for the meat market. The system does not seem more humane than the practice of feeding geese to produce *paté de foie gras*. Doubtless many people have succeeded with this system, and the present writer does not desire to sit in judgment upon them. He believes that it is everyone's privilege to appeal to his own conscience as to what is right and wrong, humane or the reverse.

## CHAPTER III

### Location

If one is seriously considering the establishment of a special poultry business, it will be well for him to study the various sections of the country in order to determine just which offers best opportunities for poultry raising. Unquestionably, the great bulk of poultry and eggs is produced in the grain states of the middle West—Ohio, Indiana, Illinois, Iowa, Nebraska and states north and south bordering upon them. In this section, it will not be advisable to go into special lines of poultry raising with the hope of securing advanced prices in the market. None of the cities in these states pays a high enough premium above ordinary current rates to warrant investment in special lines.

To reach special markets the poultryman should select some of the eastern states. Because of special advantages of soil and transportation, as well as climate, New Jersey, the Chesapeake Peninsula and eastern Virginia offer opportunities unequaled by other sections of the East, so if a poultryman wishes to go in for a special line such as egg production, broilers, capons or green ducks, he will do well to select a farm in the districts mentioned.

In deciding upon any location in this territory, it will be well to determine beforehand the cost of freights, not only on the finished product, but upon the grain and other material that must be purchased for the fowls. On this account, probably, eastern

Virginia will be better than sections in southern New Jersey because of the lower freight rate on grain from the West, and because of the through traffic from Norfolk, either by steamer or by rail, via the Chesapeake peninsula. The same remark will apply to the Chesapeake peninsula in a less degree; stations on the main line of railway being preferable to those on branches of the road, but there is no reason why in the territory under discussion, practically everything should not be raised on the farm or in the immediate locality. Indeed, it is highly desirable to make the farm produce every-

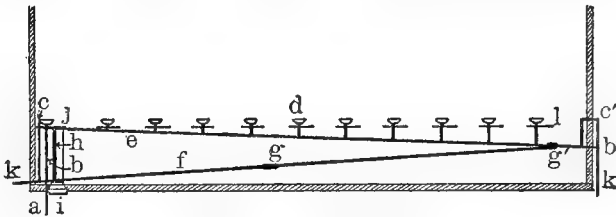

SYSTEM OF WATERING

Pipe a carries water to cups c, d, l; outlet at k. In cold weather cock is turned to drain system at k.

thing that the poultry will need, in order to work over the crude products into the higher-grade materials, such as flesh and eggs. Delaware, Virginia, southern Maryland and southern New Jersey are admirably adapted for this kind of thing. Very mild climate also favors poultry raising because with only ordinary shelter the fowls can be housed throughout the year, and for almost all the year can secure a considerable amount of their feed at range. In eastern Virginia, there is scarcely a stretch of a full week throughout the year when the



poultry cannot be out of doors. The same is true of the lower part of the Chesapeake peninsula and of coastal New Jersey.

No matter where one locates, he should own the land and buildings upon which he works. He should never rent land or buildings, because when he wishes to move he would be at more or less expense or else be obliged to leave his buildings behind. Buildings are never improved by moving. It is better to buy five or ten acres at the start and to combine other branches of farming until the poultry pays sufficient by itself to warrant extension. Truck and berry growing go well with poultry; so do large fruits, but these, of course, require much longer time to reach profitable age.

### SITUATION

The great majority of readers of this book are already situated on farms or in villages and will, therefore, be more interested in the solving of their own poultry problems than in searching for new localities. They will want to know where best to place them so as to get the largest returns from their fowls. There is no question that some situations, soils, exposures, etc., please fowls better than others, and some which are more favorable to the poultryman as well on account of convenience, but nothing need prevent fowls from paying well in situations not ideal. Fowls can easily be managed just as other domestic animals are under even wide differences both of soil and climate.

Some breeds differ more than others in adaptability but the poultryman, as a rule, holds the key of the situation on farms and villages offer-

ing abundant opportunity for profitable poultry raising. One thing is essential, namely, to supply the needs of the fowls. No matter how local conditions may vary, these ends must be met. They may be met in different ways by different people, under different conditions. All depends upon the poultryman, who must study his fowls under his own conditions of climate, soil, etc., and adjust his management of the fowls to fit the case. Until he has found by experimentation what is best for his fowls, he should not make radical changes in management but should strive to keep fowls under what are considered normal methods of management.

### THE SOIL FACTOR

Unquestionably a light soil with open subsoil is best adapted for poultry raising and a heavy soil least favorable. Doubtless many failures are due to mistakes in this respect. Rocky and untillable land is not economical, because the droppings cannot be used to produce green feed. Soils containing excessive alkali should also be avoided, because of the likelihood of damage to plumage and skin. On light soils the droppings are quickly deodorized and easily washed into the soil by rain where plants can utilize them, but on clay soils they form a hard crust which soon becomes foul.

In order to keep soils sweet, therefore, some green crop should be grown constantly on them, and yards should be large enough to allow of this practice. Alternate yards furnish the best method of arrangement for this result, except, of course, where fowls can have unlimited free range. It is

highly desirable to have as large a part of the yards as possible in permanent grass, especially if there is a considerable amount of clover in the mixture. It is not desirable to select drift sand which will not grow anything, because the droppings will be lost and thus a source of income wasted.

Land worth \$100 or more for dairying or grazing might be positively detrimental to poultry. The ordinary loamy soil, if well drained, is, as a rule, excellent for poultry, because it usually contains sufficient plant food to produce good crops. The natural lay of the land is of small consequence, as good results can be secured no matter which direction the land slopes, provided other factors are made favorable. The northern slope, of course, is not as desirable as a southern one, but where one has a northern and not a southern slope he must make the best of it. One way to do this is to protect the houses and yards by windbreaks. It is not desirable to have poultry run in timber land, because the droppings all go to waste. Orchards and plantations of raspberries, currants, gooseberries, etc., are far better, because the manure can be utilized in the fruit production and the trees and bushes made to furnish shade. Crops can also be grown between the trees and bushes and thus the fowls supplied with green food.

Always the site on which a poultry house or yard is located should be thoroughly well drained, either naturally or artificially. The water should flow away from the building, preferably through, not over, the land. There should not be standing water anywhere around the poultry yard, because this is sure to become a source of pollution. The operator is sure to have difficulty in working if the drainage

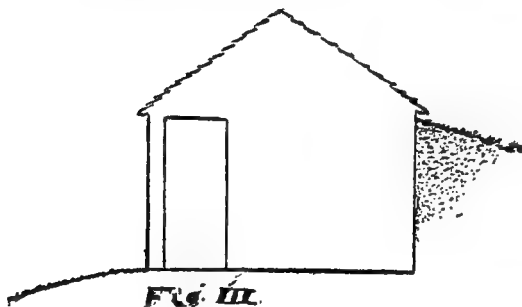
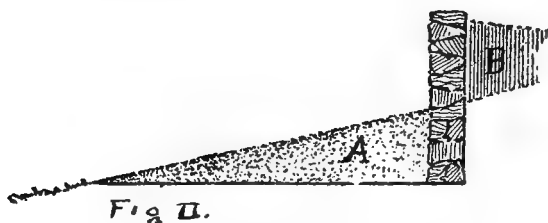
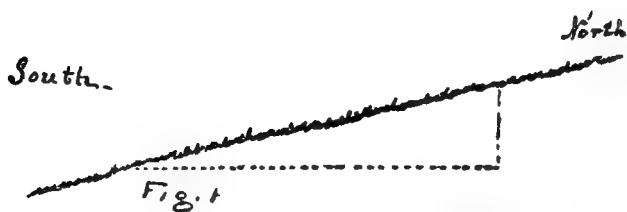

### SIDE HILL POULTRY HOUSE

Figure 1. Slope, dotted line indicates excavation. Figure 2. A. Excavated part filled in at B. Figure 3. House showing slope of surface above and below.

is not good. At all times and seasons the poultry house should be thoroughly dry. It is not necessary in order to secure drainage to select a hill or mound, nor is it undesirable to locate in a hollow,

provided the drainage is good. Preference, however, should be given to the higher sites, because of the likelihood of better drainage and warmer temperature. Cold air, it is well known, sinks into low pockets.

It is highly desirable that as much sunlight be secured as possible. For this reason it is best to give preference to a southern or southeastern slope, so that especially during the winter the house will receive the sun's rays without check. In order to raise the temperature also, the northern and western sides should be protected by some sort of windbreak, either by trees or buildings. About the worst kind of place for a poultry house is on the northern side of a barn or obstruction which shuts out the sunlight and which permits the cold northern and western winds to enter without check. Good results cannot be expected in such houses, no matter how well built. Where no other situation is available however, fowls should not be kept for any other than family purposes and should always be replaced yearly with new fowls, because the older ones quickly deteriorate and their offspring make inferior growth.

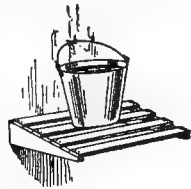

WATER PAIL  
SUPPORT

### CONVENIENCE OF WATER SUPPLY

Where one plans growing poultry on an extensive scale he should provide some means for securing water without labor. Nothing is better than a running stream where such can be secured,

but situations with brooks are rare. The next best thing is a device which supplies water by gravity from a spring or a brook higher up on the property. Without such a brook one or other of the systems illustrated elsewhere, will be found desirable, but where the supply of water is limited a device like that used in flush tanks, in which the inflow is regulated by a check valve and float, will be found better than the style which flows continuously. It is not necessary to go into the discussion of means to supply water; whether gasoline engine, hydraulic ram or windmill; the only point is to have some way whereby water can be supplied without daily cost of labor, time and money in carrying from pump to yard. While the initial cost of installation may seem large, yet the amount of money saved in the long run will usually more than offset the cost of installation.

## CHAPTER IV

### **Poultry Quarters**

It is not necessary that poultry houses should be either elaborate or expensive, but it is essential that they be dry, comfortable, pleasant, well ventilated, sanitary, convenient and preferably inexpensive to construct and operate. There is no doubt that many failures to secure good results can be traced to the poultry house itself as a building; for if it is damp, uncomfortable, cheerless, poorly ventilated, insanitary, inconvenient, or of costly construction, it is sure to produce unfavorable results. Every effort should be made to have the house so constructed that the temperature will not fall rapidly when the windows and doors are closed. It is also highly desirable that as much sunlight as possible should be admitted, especially during the winter. This can usually be done by facing the house south and preferably relying upon the south side for all the light.

Where fowls are kept in considerable number, two plans are common—the colony plan and the long-house plan. The colony, theoretically, is considered best because it affords better range, and the fowls are supposed to be healthier and, therefore, more prolific of eggs than when kept in the long-house system. This is not necessarily so. There are also great disadvantages in separating the fowls. Among these are the greater amounts of time and labor required to attend to the fowls. Anyone can figure out the cost of attending say a

dozen colony houses by measuring the distance he would have to walk from house to house, multiplying this by the number of times daily, reducing the distance to feet, then determining the number of miles walked in a day, week, month or year. The time required can then be determined by the rate at which one ordinarily walks and the value placed upon the time. It will be surprising what a distance is traversed and what amount of time can be saved by bringing the flocks under one long roof.

With the colony system there is more difficulty in securing regularity of feeding than with the long house. Especially is this so in bad weather. There is the further disadvantage that when flocks are fed at given times, the fowls will congregate near where the attendant begins to feed. There are the advantages, however, of cheaper portable houses, less expense for fencing, and the advantages of having the fowls forage for themselves. When the colony houses are placed in fenced yards, there is, perhaps, no advantage over the long-house plan.

In mild climates the objections to the colony plan do not hold so strongly as in cold climates, where there must be considerable work in shoveling snow. This remark also applies where poultry can be kept on range during the summer, especially on farms where the fowls themselves can secure much of their living by running among the growing crops. Since the colony plan is popular for such places, several styles of houses are illustrated throughout the book.

Permanent houses built on the colony plan are more costly to build than houses of the same capacity as the several separate ones when built together. This is mainly because the ends of all



but two of the houses can be saved, there being no necessity for strong partitions between the pens. As to size, much will depend upon the purpose for which the house is erected and also upon the nature of the land. Rectangular houses are more economical of lumber than houses of other shapes. As to height, it is best to have the ceiling rather low; just high enough so the attendant can walk erect without knocking his hat off. This favors warmth, because the fowls can keep the temperature comfortable if sufficient numbers are kept together. Both walls and glass, especially glass, radiate heat rapidly, so every provision should be made to retain heat as much as possible without impairing ventilation.

## PARTS OF THE HOUSE

The roof costs more than any other part of the house because of the necessity of making it water tight, and because it usually covers only one floor. Styles of roof vary greatly as to cost. While the same amount of material is required to build a combination roof, a gable roof, or a one-slope roof, provided the pitch of the ground is similar, yet the height of the sides must be taken into consideration in figuring the cost. "The steeper the pitch, the greater the comparative expense of a shed roof house over the gable or combination roof house. The steeper the roof the larger the roof area, hence the greater cost for roofing and the longer the roof will last because of its steeper pitch." The kind of material used in a roof will depend largely upon the pitch of the roof. Shingle roofs will need a pretty steep pitch; paper-covered ones can be

almost flat. The former are cooler in summer and winter, and the latter usually warmer and even hot in summer.

The essential points to secure in a foundation are dryness and wear. For permanent houses, foundation walls should extend below the frost line and high enough above to prevent the inflow of water during wet weather. Other necessary points are to have the foundation rat-proof and strong enough to support the building economically. Posts are undesirable, since the house is likely to settle, and there is always opportunity for drafts; besides, they rot. Brick, stone, or concrete foundations are best as a rule. The former requires skilled labor; anybody can construct the latter. Floors should be smooth, hard, easy to clean, dry, durable, and of economical construction. Unless ground is naturally dry, it should be drained. Too much emphasis cannot be laid upon securing dryness. Earth makes the best covering for a floor, whether there is concrete or not.

Whatever the material and construction of the walls, every effort should be made to secure warmth, dryness, strength and cleanliness, as well as durability and economy. A tight wall is essential. It is cheaper in the long run to use matched lumber than any other style of siding. This material should be planed so that it may be easily painted and thus made to last still longer. It is highly desirable to use building paper between layers, since this makes the walls extra dry. The north and west walls, or walls exposed to the wind, should be made especially tight.

Properly constructed poultry houses will not need special ventilation. It is essential, especially,

for good egg production, that there be abundant fresh air—dry air to remove dampness given off from the fowls' breath and from droppings. No way has been found so satisfactory as to have the house rather open on the front and tight on all other sides and the roof. The opening should be covered with burlap or other material to check draft and keep out snow and rain. Such houses may be somewhat cooler than houses more tightly closed, but the air will be pure, and pure air is far more important than warmth. This does not, however, mean that warmth is not also good.

No ventilating system compares in good results with the one just suggested, but where one must be put in, it is best to have the vent near the floor with a tight box leading through the upper part of the house and through the roof. The inflow of air should enter near the bottom on the outside and be conducted to the ceiling so that it will be comparatively warm before it enters the house. Thus drafts will be reduced to a minimum and yet there will be sufficient circulation of air to remove moisture and impurities. Under no circumstances should a ventilating system be given preference over the more natural diffusion system already mentioned. The difficulties of making the thing work increase as the temperatures inside and outside approach each other, and also as the openings in the house increase.

The styles of poultry houses and the arrangements of pens are legion. The open scratching shed is favored by many since it provides space for the fowls to exercise in spite of any kind of weather. All sorts of modifications of this style are found and good results secured as a rule. The plan has

some advantages over the closed pen. It is cheaper in cost and demands less labor. Perhaps its chief advantage is that the fowls may go from house to shed, or the reverse, and thus feel more at liberty than if confined closely. They are also less likely to become excited if they have a means of escape when they want to get away from an attendant. Everything that makes for comfort, therefore, should be secured when possible. The scratching pen is considered essential to good health of the fowls, because it insures exercise and the fowls are not confined in too warm a room while they are busy.

### MODEL POULTRY HOUSE

There are a few features of the model house, built by J. W. Griffin of Kentucky and illustrated herewith, that could be added to any large poultry house with profit: the hooded roost with curtained

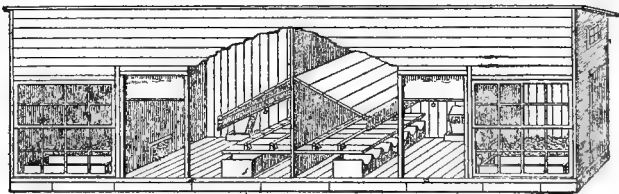

J. W. GRIFFIN'S POULTRY HOUSE

front, the arrangement of the nest boxes, the location of the dust, grit and oyster-shell boxes. The roosts of the two rooms being near each other make it warmer at night for the fowls. The large windows are screened on the inside; the curtained

openings screened outside. The opening in the sketch shows the position of roosts, curtains and nest boxes. There is a 1-inch crack all around the top of the house for ventilation.

Under the dropping boards behind the nest boxes is a place for storing forest leaves or straw for scratching shed. The dust boxes are 1x2x5 feet; the curtains are heavy sheeting; the nest boxes are cracker or canned goods boxes. A form for the foundation, 10x32 inches, is made, the wall to be 1 foot above the level of the ground and 6 inches thick, made of concrete; then 3 inches of soil.

The entire size of the inside wall should be thrown around the outside of the wall to drain off the surface water. This leaves an opening inside the walls 9x13x15 inches. The excavation for walls should be 1 foot in the ground. This opening should be filled with coal cinders to within 4 inches of the top. When putting in the concrete for walls, anchor bolts should be set in for fastening 2x6-inch sill directly on the walls. Bolts  $\frac{3}{4}$ -inch sunk in the concrete 6 or 8 inches, with  $2\frac{1}{2}$  inches sticking up will do, placing four on each side.

Now we are ready to put on the sills. After the sills are on there will be an opening 6 inches deep for concrete. Put on 5 inches of grouting and finish with 1 inch of pure sand and cement. Strike off on a level with top of sill. Then we will be ready to lay the floor over all. Let siding lop down 2 inches over sides of wall. The coal cinders afford perfect drainage, and prevent any dampness rising through the floor. The floor, being laid directly on the concrete, is rat proof from below. The front is 10 feet high and rear 8. The following bill

of stuff will build it, including carpenter and concrete work at \$3 a day:

- 1,000 feet ship lap for siding partitions and covers of roosts.
- 400 feet flooring for floor and dropping boards.
- 385 feet common flooring or sheeting.
- 4 pieces 2x6 inches 16 feet oak for sills.
- 34 pieces 2x4 inches 16 feet oak for stringer and ties.
- 20 pieces 2x4 inches 10 feet nail ties and frame stuff.
- 2 windows 16 feet lights 14x16 inches scratching shed.
- 2 windows 4 lights 12x14 inches ends.
- 20 yards sheeting or burlap for curtains.
- 14 yards wire netting.
- 20 boxes for nests.
- 6 rollers with springs for curtains.
- 4 pair strap hinges.
- 3 $\frac{1}{2}$  squares of paper-lined iron roofing.
- Carpenter and concrete work.

The estimated cost is \$186.50, figuring lumber at \$2.50 per 100 feet, and roofing at \$3.00 per 100 square feet.

## OPEN FRONT POULTRY HOUSE

Fresh-air houses mean cheaper construction, more comfort, no ventilation to worry about, warmth in winter and coolness in summer, more eggs, better chicks and better profits. They are

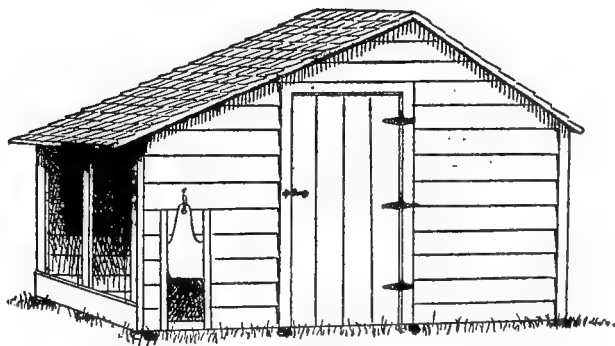

FRESH AIR POULTRY HOUSE

believed to be the best and most practical houses that farmers can use, since they save both in labor and money.

Next to the tight or closed house is the curtain front house, with a scratching shed. In this style one is obliged to provide a combination building, which practically means two houses to each flock, an open front shed and a closed roosting house. As the fowls during the greater part of the time are in either the shed or the roosting house, and

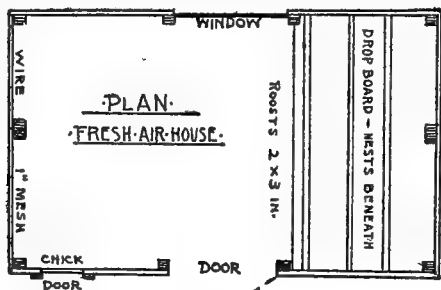

GROUND PLAN OF HOUSE

must occupy the latter at night, one has a house capacity equal only to the size of the roosting house, no matter how large the scratching shed may be. At night it has all of the advantages of the closed house. These fowls spend a very large part of their time on the roost. They need fresh air while there, just as much as they do at other times, probably even more. In closed roosting quarters they have to breathe impure air, and that means loss of vitality and liability to disease. The open front is superior to the curtain front, because as the latter is much

more complicated a great deal depends upon the judgment of the operator in using the curtain.

A large house adapted specially for the large market-egg plants is also ideal for the farmer, because it saves much time and labor. It is 14x 24 feet. The door is placed on the east side about half way between front and back ends. Directly opposite are two windows. The front or south side is open night and day, but is covered with 1-inch mesh poultry wire netting. If the house is situated in a very bleak and exposed place it is well to use only  $\frac{1}{2}$  or even  $\frac{1}{4}$ -inch net. This will keep out more of the drift snow than the larger mesh netting.

Some poultrymen criticize the low front, because they claim the sun does not shine far enough back. This is not so. The winter sun in this house, which faces south or slightly to the east, shines into the building 8 to 10 feet back from the front in December and January. It gets into the building early in the morning and shines full until late in the afternoon. The west window admits additional sunlight in the afternoon to the rear part of the building, thus giving sufficient sunshine. Some have suggested a window across the front side of the south roof, so as to let in more sun. This is not advisable, because the window would make the house much colder when the sun is clouded and also during the night. One of the strongest features of the house is that the temperature changes very gradually.

As will be seen from the drawing the building is a plain hip-roofed one, with a long pitch or front to the south. The one described herewith is 8x14 feet long. The roof and closed sides are of 1-inch boards covered with shingles, so that the east,



west and north walls are tight. The eaves are about 4 feet from the ground and the peak slightly over 7 feet. The approximate cost of material for this house is \$20. It will include the items given below. Prices, of course, will vary with locality.

300 sq. ft. hemlock boarding No. 1 at \$22 per M.....	\$6.60
40 running ft. 2x4 joist, 157 running ft. 2x3 joist 105 ft. at \$28 per M.....	2.94
One window, 7x9.....	.95
Window frame for same.....	.70
1¼ thousand \$3 grade shingles to be laid 5 in. for roof..	3.75
1½ thousand \$2.50 grade shingles laid 6 in. for sides....	3.75
<b>Total</b> .....	<b>\$18.69</b>
Extras .....	1.31

## KNOCK DOWN COLONY HOUSE

A considerable saving of lumber can be made by using knock-down poultry coops and colony houses. These may be made of any convenient size. In construction two runners with notches near their

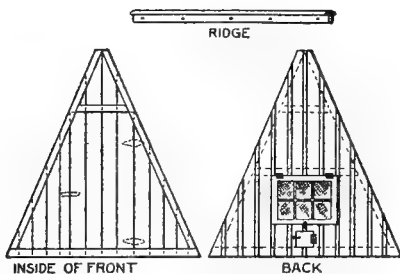

FRONT AND BACK OF COOP

ends are laid down and two crosspieces, also notched, are screwed, or preferably bolted, to them. The runners are provided so the house may be hauled from place to place. The crosspieces are to

support the side walls. At the ends are bolts which run through the side wall, to which they are fastened by nuts and washers. The ridgepole is

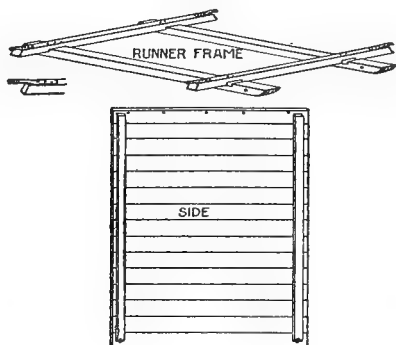

FRAME AND SIDE OF COOP

fastened to the sides by bolts also. The same with the ends, which are made triangular, as shown.

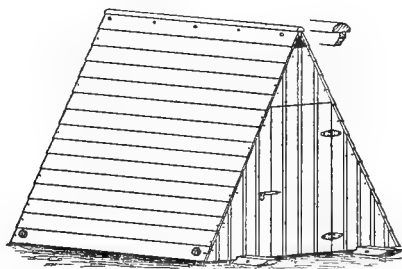

COLLAPSIBLE COLONY COOP

As these houses are intended only for summer use, they may be built of comparatively light material, with clap-boarding for the sides and ship

lap or matched stuff for the ends. It is desirable that not more than 50 chicks be kept in one colony house, and that each flock have a grass plot of at least 1,000 square feet, unless the chicks can have free range.

These houses are also useful to shelter brooders in the early part of the season. If the houses have a floor space of 6x6 they will each accommodate 50 chicks without crowding, and when the chicks are old enough to do without the brooder they can be allowed to range from the house itself, thus becoming accustomed to their quarters from the very first. A convenient size for the house illustrated is 6x6 on the floor and 7 feet to the peak. These allow a man to stand up inside and to attend to the brooder and chicks without inconvenience. They can be built of odds and ends of material, but if new material must be bought, and if the house is painted, as it should be, it would cost about \$8. If unbolted and stored under cover as intended, such houses should last for many years, so the first cost would be insignificant compared with the life of the houses themselves.

## CHAPTER V

### **Poultry Fixtures and Devices**

Much of the comfort of a poultry flock and much of the convenience to the poultryman depend upon the fixtures and devices adopted in the houses and yards. Scattered throughout this volume, therefore, are drawings illustrating many devices for the convenience of the poultry raiser and the comfort of the fowls. It will not be necessary to discuss these at length, because the drawings furnish sufficient means for any one handy with tools to make them without difficulty. A few words, however, may be said in a general way as to the desirability of certain styles of apparatus.

Roosts should preferably be placed comparatively near the floor of the poultry house, so that fowls will not have difficulty in flying up or down. This is especially desirable where heavy breeds are kept, because these fowls not only find trouble in reaching high roosts, but in flying down they are very likely to injure their feet or legs, and even fowls of the light breeds may injure themselves in the same way if the floor is hard, as it usually is. All roosts should be on the same level to prevent fowls from crowding one another, as they will do if one roost is even a trifle above another. The desire of the fowls is to reach the topmost boughs of the tree to be out of the reach of enemies, but as enemies are kept out of the poultry yard there is no reason why fowls should climb high.

Usually fowls crowd together upon the roosts even in warm weather and when there is plenty of room. They should not, however, be compelled to sit closely. It is well to calculate on about 10 inches for each Asiatic fowl, 9 inches for fowls of the American class and 7 inches for Mediterranean breeds. Roosts should be placed about 8 inches above the dropping boards, which should be somewhat longer than the roosts themselves. For light fowls 2x2-inch scantling with rounded corners is very popular, especially if the roosts must be rather long; but where short roosts are used 1-inch stuff 3 to 5 inches wide is often used. For convenience roosts may be made to lift out of the way by some

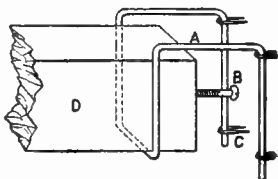

VERMIN-PROOF ROOST

Staples, C, hold wire bracket, A, for roost, D, kept in place by screw B. Remove often and dip end in kerosene.

such device as illustrated herewith, so that cleaning may be undertaken without difficulty. Always the upper edges of the roost should be rounded. One important thing about roosts is that they should be easily removed for cleaning, especially to get rid of lice and mites.

Dropping boards are used for convenience in cleaning and to prevent dust. If the houses are well kept they are very useful, but if cleanliness is not observed they are worse than nothing at all, because where the droppings are allowed to stay from day to day the boards become saturated and offensive odors are given off, thus making the quarters exceedingly unpleasant as well as unhealthful for the fowls. Matched flooring or sheathing which

provides a smooth surface is most popular, preferably the boards should be about 20 inches wide for single roosts and 3 feet wide for double ones. They should have strips of light material about 2 inches wide extending above their edges to prevent the scattering of the droppings; they should be cleaned every day.

### STYLES OF NESTS

Nests are probably the next most important necessity in the poultry house and may be made of any kind of material, style or character, provided there are no egg-eating hens in the flock. Grocery boxes are very popular in such cases, but where many hens are kept, and where sitting hens cannot be put in some building apart from the main flock, the nests should be arranged to fit such conditions. Preferably the nests should be darkened and placed in secluded parts of

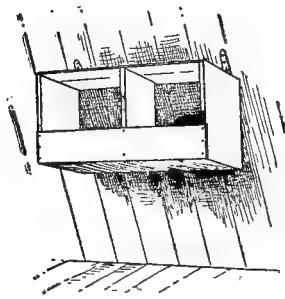

HANDY NESTS

An orange box without back and hinged to the wall is quickly cleaned by lifting. the house or even in the yard. A favorite place for them is beneath the roosting platform. Where egg eating is discovered, the dark nest is one of the best ways to eliminate the habit. A nest which allows the egg to roll beyond the hen's reach is even better.

Trap nests in considerable variety are illustrated throughout this volume. (Pages 100 and 101.) Their principal advantage is that they show the

poultryman which hens are the layers and which the drones. Where one is breeding for egg production they are a necessity, but where one is keeping hens for market only some of the nests that open into two different pens will be found advantageous, because they will allow only such hens as have laid to pass from pen to pen, unless hens discover that they can make progress in this kind of way and thus

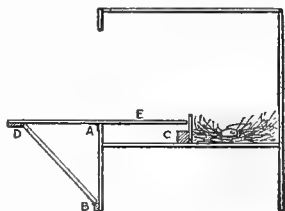

SIMPLE TRAP NEST

cheat the poultryman. This fact, however, can be readily discovered by counting the number of eggs in the nests and also by counting the number of hens in the pen which was empty in the morning. The way they are used is to have all the hens in one flock in the morning; to count the eggs and in the evening count the hens in the second pen before returning them to the first one for the following day's laying.

Feeding vessels are of many kinds, several of which are shown. The common V-shaped trough is the simplest, but is objectionable because the fowls are likely to soil the food by standing in it. For cleanliness' sake food, whether dry or wet, grain or ground, should be protected so the fowls cannot soil it. Several types of hoppers suitable for feeding dry mash are illustrated; also devices for protecting the food of young fowls from larger ones when birds of different ages must be kept together. Feeding vessels should be kept scrupulously clean.

Fountains of various styles are shown in this volume. The principal point to remember in connection with them is to keep them clean at all times. The material from which these vessels are made is of no consequence and neither is the style, provided cleanliness is maintained. The most important thing, therefore, is that the fountains be protected so the fowls cannot get anything but their bills into them; even where open drinking vessels are used this should be insisted upon. There is no reason why metal of any ordinary kind should not be used as freely as crockery ware. There is no more danger of poisoning from oxidized tin or iron that the fowls might drink than there is of human beings so becoming poisoned. Drinking devices should be such as can be quickly filled, quickly cleaned and quickly replaced. They should be placed as far from the dusty portion of the pen as possible so as to avoid becoming soiled by dust or material scratched into them. Preferably they should be elevated well above the floor. The best device for a range of houses is unquestionably a continuous pipe with fountains that rise in the various pens.

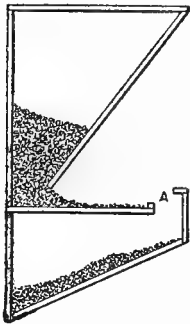

FEED-SAVING  
HOPPER

Grain or meal that hens would waste drops into lower compartment.

be placed as far from the dusty portion of the pen as possible so as to avoid becoming soiled by dust

or material scratched into them. Preferably they should be elevated well above the floor. The best device for a range of houses is unquestionably a continuous pipe with fountains that rise in the various pens.

Grit and shell receptacles should preferably be of metal and placed where the fowls will not scratch litter into them. They should be cleaned weekly.

Brood coops for sitting hens and hens with broods are illustrated in considerable variety. Probably



the commonest style is the A-shaped coop with various modifications as to runs, character of material, etc.

Colony houses of several styles are also illustrated merely to give hints. No comment need be made on these except to say that they are exceedingly convenient for placing in orchards and fields, where by the aid of hoppers and drinking fountains the flock may be encouraged to take care of itself to a large extent. After the chicks reach a fair size and the hen has left them, roosts should be placed in the house. Since some chicks take to the roost slowly, provision should be made for them in some other corner of the house so they may cuddle on the ground without danger of being soiled by droppings from the fowls on the roost.

Incubators and brooders need not be discussed here as part of poultry equipment, because they are taken up in chapters devoted respectively to hatching and rearing. Bone cutters are considered a necessity where large flocks are kept. Green bone can often be purchased from local butchers at so reasonable prices that where small flocks are kept a bone cutter need not be part of the poultry equipment, but where considerable quantities of fresh bone are required a good machine is a great advantage.

Hay cutters are useful where large numbers of fowls are kept and where there is not much broken

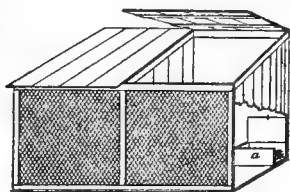

DOUBLE BROOD COOP

Any convenient size.  
Hinged lids; wire front;  
board floor covered with  
sawdust.

hay from the barns. On the ordinary farm the live stock hay cutter will serve if it can be gauged to make a very small cut; but for the business poultryman a machine built for poultry requirements should be given preference. On most farms there will be sufficient broken clover tops and leaves to supply the hens.

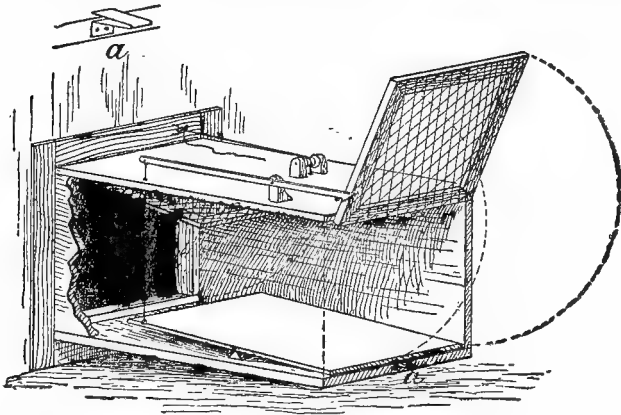

TRAP FOR PROWLERS

At night inner door closed. Animal steps on rocker bottom and springs latch. Outer door falls and catches on latch, a.

Grit crushers are not essential on most poultry farms, because the fowls, if at free range, can secure sufficient grit while foraging, but on soils deficient in gravel grit in some form must be supplied. Where gravel is lacking in the neighborhood it may be more economical to buy grit already prepared.

Feed mixers and feed cookers are on the market, but usually the farmer has some large kettle that will serve for cooking mashes. It is generally

believed, however, that warm mashes have only slight advantage over dry mashes, and as they are more costly to feed on account of the labor involved they are not very popular.

Prowler traps are useful where there is danger of foxes, minks, weasels, etc. There is a considerable variety of these, but only one is illustrated. (See page 72.) The important thing to remember in setting such a trap is to avoid touching any of the parts. If the trap can be set without the poultryman coming near it, so much the better,

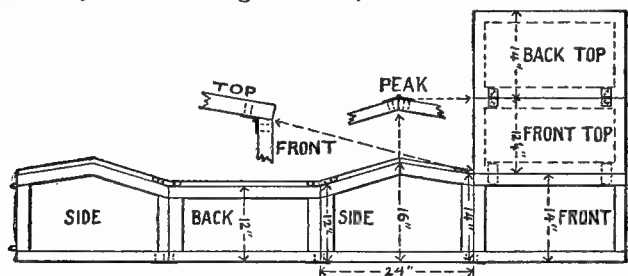

COLLAPSIBLE COOP

Sides, back, top and front hinged. Held in coop form by two pegs in eyelets at left and right. Coop can be stored flat under cover.

since this will not arouse the suspicion of the would-be thief, who might otherwise smell the human hand or footprint.

Coops for broodies are often used where artificial incubation is practiced or where the poultryman wishes to make hens recommence laying. A favorite style is a coop with a slatted bottom and wire-netting front raised well above the floor. The hen is placed inside and feed and water are hung within reach. (See page 32.)

Knock-down Houses and Coops.—Several styles

are illustrated to serve as examples. The principal advantages of these houses are that they can be taken down and stored flat from season to season and thus be made to last considerably longer than the material ordinarily would if made into coops that could not be stored conveniently under cover.

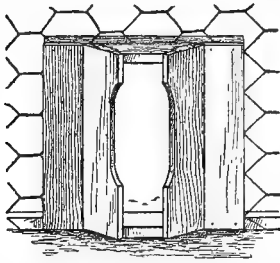

HEN GATE

The frame is placed in the fence. Hollowed doors, hinged at top, swing inward when hen enters. Then they fall shut.

An egg cabinet is a useful device for holding eggs for hatching. It enables the poultryman to turn a large number of eggs in a very short time. Two such devices are illustrated, one for a small the other for a large number of eggs.

A popular style is an ordinary egg case of rather small size which can be turned over from day to day.

Poultry gates should all be self-closing, either by weights or springs. Often hens escape from the poultry yard and wander up and down outside trying to get in. To provide opportunity for this a little gate may be inserted in the wall, preferably

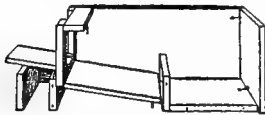

TREDDLE TRAP NEST

Door closes when hen steps inside.

at some corner where the hen may be driven. Enough opening should be made around the gate itself to encourage the hen to poke her head against the gate and thus enter the yard.

Such gates should swing shut of their own weight rather than by springs, because this leaves nothing to get out of order.

Shipping coops (page 000) should be made of light material and preferably covered with canvas. They should always be made high enough to accommodate the fowl without stooping and large enough in other dimensions to allow for as many fowls as there are to be shipped therein. This applies just as much to the crate for shipping fowls alive to market as to the crate used for exhibition fowls.

### TRAP NEST MADE FROM ONE BOARD

The Oregon experiment station gives the following directions for making a trap nest from one board 12 inches wide and 10 feet long. Anyone who can use a saw and drive a nail can make it: (See page 76.)

One board 1 inch thick, 12 inches wide and 10 feet long; 6 screw eyes No. 210 bright; 2 pieces round iron, 3-16-inch long by 12 inches wide; 2 pieces rawhide 9 inches long by  $\frac{1}{2}$ -inch wide. With a square, lay off the board as shown in the accompanying diagram. The shaded portions are the waste pieces of the board. The solid black lines show where the board is to be cut. After sawing the pieces, the nest is ready to be put together.

1. Nail the sides to the bottom so that the ends will be even.
2. Stand the nest on end and nail on the back. This will square the sides.
3. Stand the nest on its back and nail on the front piece.
4. Nail on the front brace, which should be set into the sides at lines indicated at A and B.
5. To the end of the bottom board nail the nest end front.
6. The two front pieces are nailed on either side of the door to the sides and the front brace.
7. Put in the piece (10 $\frac{1}{2}$  inches by 3 $\frac{3}{4}$  inches) on which the door is balanced; nail it in between the sides so that the inner side will be flush with the outer side of the front pieces. In this piece put a screw eye 4 inches from each side, the outer edge of the screw eye being flush with the inner side of the piece.
8. Turn the nest on its side and bore the holes in the sides through which the 3-16-inch iron passes. The holes are 1 inch from the bottom and 1 $\frac{1}{4}$  inches from the nest front.
9. On the bottom of the tripboard put in a screw eye  $\frac{7}{8}$  inch from end and 1 inch from each side. At the other end of tripboard bore two  $\frac{3}{8}$ -inch holes 1 inch from the end and 3 inches from each side.
10. On the bottom and at each side of the door put in a screw eye 1 $\frac{1}{2}$  inches from the end and  $\frac{3}{4}$ -inch from the sides. On the upper side tack the two rawhide strips, using a small staple or nail for each. The strips are tacked on so that the end of the strap will be 2 inches from the end and  $\frac{1}{2}$ -inch from side of door.
11. Place the door in front of the trip-

board, the screw eyes down; push the rawhide strips through the holes in the tripboard; turn the boards over and draw the strips up tight; then bend the door back over the tripboard until there is a full  $\frac{3}{4}$ -inch between the board when laid flat; the strap should then be tacked to the lower side of the tripboard. 12. Put the door and tripboard in place. This is done by pushing the iron rods through the sides and the screw eyes. Care should be taken in placing the screw eyes in proper places; if they are not set properly the door will not balance.

The nests may be built singly or in groups. They may be set in the wall of chicken house under the droppings platform, where a platform is used. This plan will save the cost of covers. In either case it will be an advantage to have nests

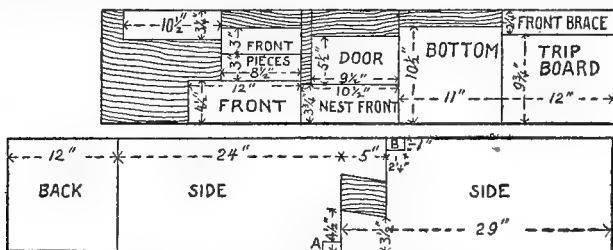

BOARD MARKED FOR TRAP NEST

This provides for least waste in cutting.

made separate and a frame made to receive them, so that the nest may be pulled out to release the hens. Occasionally a hen is slow in coming to the door to be let out, and by pulling the nest out the operation of releasing the hens may be more quickly performed. If the nest is to be used outside of the house, it will be necessary to put a cover or roof on that will protect it from the weather.

The dimensions of the door and the size of the opening for the door are given for medium-sized breeds. For large breeds it will be necessary to enlarge the opening. The front brace may be raised and the front pieces made narrower. The door opening should not be large enough to admit two hens at one time.

## CHAPTER VI

### Breeding and Breeds

Such proofs as the following show the reason why pure-bred fowls, especially of utility strains, are replacing the scrub fowls on farms throughout the country. This case happens to be with White Leghorn fowls; it would be similarly true were the fowls Plymouth Rock, Wyandotte, Rhode Island Red, or any other utility breed.

Fifty White Leghorns were compared with 50 mongrels for one year at the West Virginia experiment station as to cost of food and egg production, ordinary care and attention being given them such as they would receive on the average farm. In addition to skim milk used to moisten the mash the Leghorns consumed 61 pounds of food, costing 85.3 cents a hen, and the mongrels 66.8 pounds of the same materials, costing 92.1 cents. During the year the Leghorns laid 116.5 eggs, worth \$2.24, and the mongrels 96.1 eggs, worth \$1.78 a hen. The Leghorns gave a profit over the cost of food of \$1.39 and the mongrels a profit of 86 cents a hen.

The mongrels gained in weight 1 pound a head more than the Leghorns. If this increase in weight is taken into consideration then the Leghorns still gave a profit of 40 cents a hen more than the mongrels. The highest prices for fresh eggs usually prevail between November and February. During these four months the mongrels laid only 364 eggs, but the Leghorns 1,029, or practically three times

as many. Is there still any doubt as to which is the more profitable to keep?

It is essential to have a clear idea of what is wanted when breeding. In one's own yard, a desired end is easily attained by eliminating from the flock birds which lack qualities sought and bringing together those that most nearly approach a given ideal, be this egg or meat production or show points. But many who desire to improve their flocks by the introduction of new blood have been disappointed in the birds reared from eggs or purchased from breeders.

This mistake usually arises from overlooking the difference between show and utility strains of the same breed. Birds bred for one purpose are almost invariably inferior for the other, and this with no blame attachable to the breeder. It is the breeder's point of view or idea which does not coincide with that of the purchaser. Most farmers raise poultry for eggs or meat, or both. But even so it will always be safe in writing a breeder to determine as nearly as possible how his ideas of poultry-breeding approach one's own and thus narrow down as nearly to the right birds as possible. It must be recognized also that while the general purpose fowl is a universal desire, yet it has not been secured. By trying to combine show points, egg laying and meat qualities in the one bird an aspirant is almost sure to be disappointed in each direction.

As to picking out the highest scoring bird as the best layer, don't try to do it. Nine times out of ten she may prove a poor layer. Exhibition birds are forced for show, not for eggs; and it takes considerable time to get them back into breeding con-



dition. Birds intended for laying eggs and breeding purposes on a large scale should never enter the show room. Another point is that the highest scoring fowl, if carefully and scientifically bred, is apt to be bred in-and-in for points only.

### WHAT TO SELECT

When one selects fowls, he should take those that please his fancy and learn to care for and handle them so as to have the best results from them. Some varieties will naturally lay more eggs than others, while others are the best general purpose fowls. The advantage of one may overbalance the best qualities of the others; for these reasons select the breed or variety that pleases the fancy best and give it the best possible attention. Two faults count against success with poultry—carelessness of management and the lack of exercise and fresh air for the hens.

Any breed of variety of standard-bred fowls will, if properly handled, do well, and return a profit for their keep. If as much care and attention were given to handling the fowls for best results as is given to the question of what fowls to keep, all would do better with their fowls. It is a question of proper care of what we have, rather than a selection of what we shall keep.

When you conclude to purchase stock or eggs, do not look for double what you could furnish for the same value. What might be called a first-class breeding bird will cost anyone who produces him from \$3 to \$4 actual outlay of time, trouble and feed. Take the value of the eggs set, the value of time expended and the feed consumed, and in addi-

tion to this the numbers that die or are killed for poor quality, and those that reach maturity will cost even more than is often contemplated. For these reasons, no one can sell a good stock bird for less than \$4 and get full cost; the profit, if any, must come from those sold at higher prices.

### CAUSES OF FAILURE

These conditions furnish the real reasons why so many can make no money out of their stock. The fowls are either regarded so poorly that they will not sell for any value, or when well raised they sell for less than it costs to produce them. Good stock is always well worth full value, but when the purchaser does pay this value he should get what he pays for.

He should ponder well the fact that the world always did and always will put a premium upon the best goods and the best things. Among the thousands of breeders of standard-bred poultry very few, comparatively, control the trade in high-priced stock. These men stand for all that is really best in the respective breeds they handle. They are making money annually, while hundreds of breeders are about playing even, and many not doing that. These men have simply brought to their work a fancier's love and instinct, and by careful and systematic breeding have established strains of fowls that are the best representation of the breeds.

There is abundant room in this field for others. The field will never be filled. It is the field wherein is reaped the pleasure and the profit of standard-bred poultry breeding; and, best of all, it is where the fancier secures that satisfaction with self which

comes only with the consciousness of a duty well performed.

## UTILITY BREEDING

Scientific breeding is deserving of study by every one interested in the utility side as well as by those attracted to the fancy side of poultry raising. No farmer can afford to ignore the profit to be derived from the proper handling of even a small flock. Common hens are well enough in their way and by scientific breeding might in time be developed into heavy laying strains, but practical people are more interested in what has already been accomplished along such lines. They want stock that will produce the most eggs and meat at the minimum cost of feed. Certain Leghorn strains will produce more eggs than any other known breed, because for many years they have been systematically bred for great egg yield. Under certain conditions like will produce like. A pullet from a strain of great layers should be a great layer; if bred to a male descended from a strain of great layers, the females of this progeny should be greater layers.

Listen to this experience of a farmer who kept common hens and who had read of the great egg yield of certain strains of pure bred, but could not afford to buy such stock because he needed every dollar to pay off the mortgage on his home. With a neighboring fancier he exchanged a day's hauling for a sitting of White Leghorn eggs, from which he succeeded in raising two pullets. Then he wished to buy a male of this breed, but changed his mind when he learned the price asked for the one he selected was \$25.

## HOW THE PLAN WORKED

This man was a reader and a thinker. "It's eggs I want," he reasoned, "not show birds;" and he selected the best yearling male from his flock of common fowls to breed to the two pullets. Every egg from that pen was carefully kept and set, and that fall he had 30 pullets and 4 cockerels, each half the blood of the dams, and those half-breed pullets shelled out the eggs all the fall and winter.

In the spring he selected his best half-breed cockerel and mated him to the two Leghorn hens. The eggs from that mating were again kept and religiously cared for, and that fall he was rewarded with 50 chicks three-quarters Leghorn blood. Again he selected the best cockerel and the following spring mated him to the original Leghorn hens. That year he raised but 15 pullets and 2 cockerels from that pen, but these chicks were seven-eighths the blood of the dams, practically full-blooded White Leghorns. The half and three-quarter blood pullets had all been kept and had produced many more eggs than his common stock, and the sale of those eggs helped to pay off the debt on the home.

## LINE BREEDING

This system is called line breeding, which is scientific in-breeding, and may be more readily understood by reference to the chart on the opposite page. The solid lines in the chart represent the course of the male blood and the dots the female blood lines. Suppose a pure-bred cockerel represented by group 1 to be mated to the pullets in group 2. The progeny of this mating would be represented by group 3.

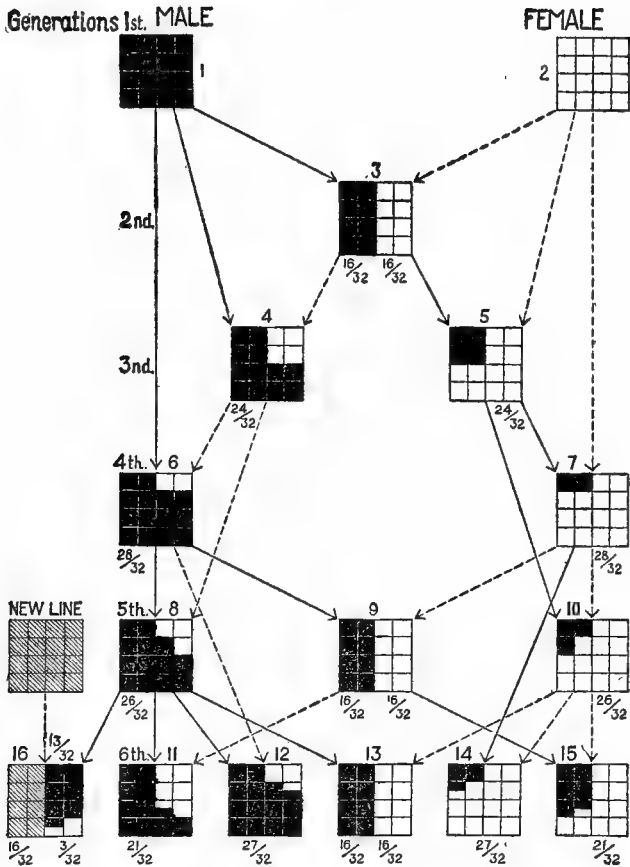

BREEDING CHART. (See page 82.)

The pullets in this group are mated back to the cock in group 1 and the progeny would appear in group 4 as three-quarters the blood of the sire.

The pullets from group 4, when mated to the cock in group 1, would give progeny in group 6, the chicks in which would be seven-eighths the blood of the sire, or practically pure bred so far as utility requirements go.

The chart is extended to show how other combinations occur. In group 9, produced by crossing a cockerel from group 6 with pullets in group 7, and also in group 13 produced by crossing a cockerel with pullets in group 10, the result is half breeds as in group 3. Group 5 results from crossing a cockerel in group 3 with the hen in group 2. The

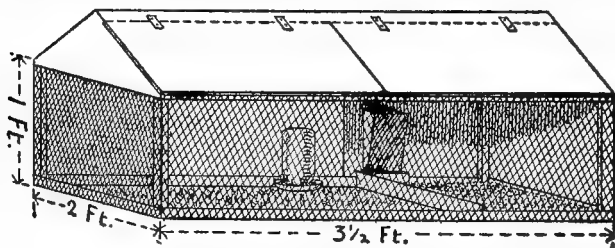

PORTABLE RUN FOR CHICKS

Frame of light wood 1x2 inches; netting sides; light wood top; hinged. Grass and earth divisions.

progeny in that case would be seven-eighths of the blood of the mother instead of the father as in group 6. In group 10, the chicks result from a cross of a cockerel from group 5 with pullets in group 7. The reverse of this is the case in group 8. Groups 11, 12, 14 and 15 explain themselves.

Should it be thought desirable to introduce a new line of blood, it is best to do this through a pullet or a hen mated to a cockerel as shown in group 8. The reason for selecting a female is that it is safer

than to purchase a male whose influence might not be as desirable as hoped for. The progeny of one female could be more easily kept separate than the progeny of a male mated to several females. The proportions of blood would be somewhat similar to that in group 3; namely, there would be half the blood of the new female with  $\frac{13}{32}$  of the blood of

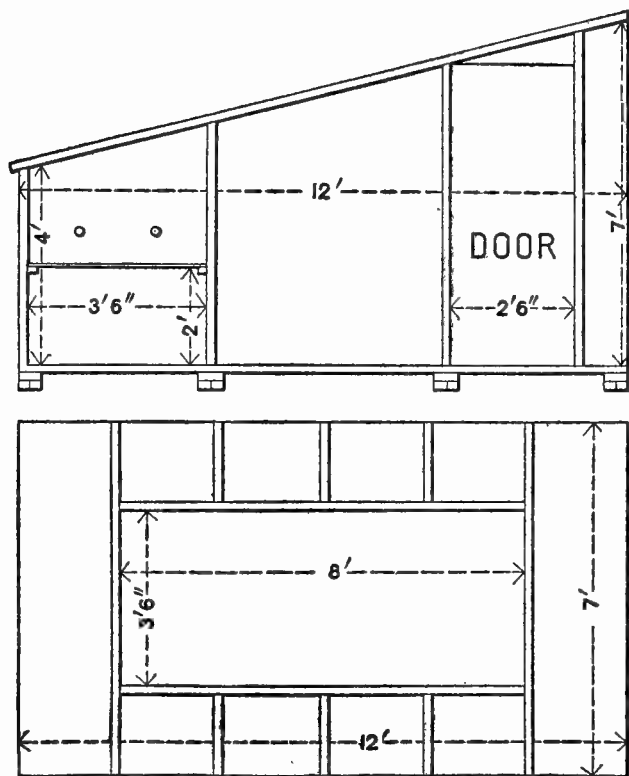

POULTRY HOUSE, ELEVATION AND GROUND PLAN

the original cock in group 1, and 3-32 of the blood of the hen in group 2.

From the foregoing discussion it is evident that great care must be exercised to prevent breaking up the system of breeding; for by carelessness all the good results may be lost, since the progeny will be thrown back into one family and thus indiscriminate breeding result in ultimately spoiling the flock. It is highly desirable, therefore, that the plan be definitely laid out beforehand and followed without deviation in any respect. If the best results are to be attained, the chart should be made and its tracings followed systematically from year to year. Without the aid of the chart careless breeding is sure to result and the whole system be spoiled by injudicious matings. If the lines of the chart are carefully studied and followed, a great improvement may be shown in the ordinary farm flock as instanced above. Thus flocks may be made more profitable at the cost of only a little thought and care.

There is only one more caution to be made and that will be guessed from other portions of this

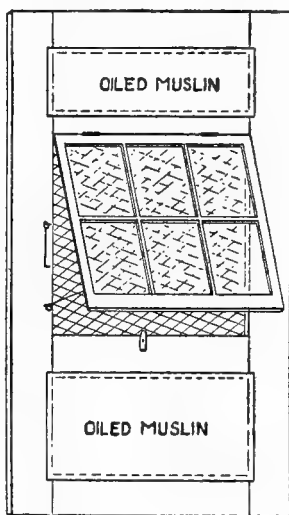

VENTILATING DOOR

Door frame with two panels of oiled muslin and hinged window, protected by wire screen. Suitable by adjustment to all weathers.



chapter. It is essential to select the best individuals in each generation so as to secure the largest proportion of improvement. By this system, it will be seen that while no brother and sister matings are made, the system is practically that of in-breeding. On this account any faults in the parents are likely to be exaggerated in the progeny, just as excellencies are. For this reason too much care cannot be taken to avoid mating individuals which exhibit the same kind of faults.

### COMMON MISTAKES OF BREEDING

As ordinarily managed, poultry quickly degenerates. This is largely due to mistakes of breeding. When a small flock is kept, the poultry raiser may purchase or select a good male bird to head the flock. This in itself is not necessarily bad, but the way it too frequently works results disadvantageously.

Suppose a case in which the hens have different ability as to good laying; some lay well, some poorly. It is likely with such a flock, unless an incubator is used for hatching and care is exercised to select eggs from the good layers alone, that when the good layers sit they will hatch eggs which the poor layers have laid. Thus the chances for rearing a good laying flock for the succeeding year are reduced at the very outset. But suppose that some of the eggs set are laid by the best layers. These eggs are by no means the best that the hens have laid; the chances are they are the poorest, because the hens may have been laying for weeks, or even months, and may be tired. Thus the chances of producing good layers are very slim. In fact, a

great majority of the chicks raised will be the progeny of the poorest hens in the flock.

On this account, more than for any other reason, the grading up of a mongrel flock by the introduction of new blood through a rooster is far less satisfactory than is usually supposed. The obvious way of overcoming this difficulty is to remove the best layers from the balance of the flock and to keep their eggs separate for hatching. In order to be sure which are really the best layers, one of the trap nests should be used or close watch should be kept upon the fowls.

The same sort of thing occurs in the ordinary farmer's flock where 100 or more hens are kept, and where half a dozen or more cheap cockerels are allowed to run at large with the hens. In this case, the chances of securing really desirable eggs are greatly reduced, because there is no certainty whatever about the mating, and just as in the former case the chances are strongly in favor of spoiling the results of any breeding that may have been emphasized by the breeder of the cockerels. Very few eggs laid by the best layers mated with the best cockerels will be set, so that in this case the chances of improving the flock are far less than if the same amount of money had been spent for one really superior cockerel or cock and this bird mated to half a dozen or a dozen of the best layers on the place. It is better to put \$5 or \$10 into one superior cock and use this bird with the selected hens than it is to spend the same amount of money on half a dozen or more cheap cockerels to practice the foolish method herein condemned.

From these foregoing paragraphs, the importance of culling cannot be too strongly emphasized. It

is much more to the farmer's interest to raise a small brood of really superior fowls which will lay well and therefore pay well than it is to raise a large number of inferior fowls which unless sold for meat will not only lay poorly but will actually eat food that might be fed to the smaller flock at a profit. It is idle to say that close culling will prevent the rearing of sufficient numbers of chicks. On the contrary, it is highly probable that with breeding stock of a superior character and in ample room, especially where well cared for, the breeder will hatch and rear a large percentage of chicks, and such chicks will be of greater commercial value because more likely to be productive.

### **IMPORTANCE OF CONSTITUTIONAL VIGOR**

There is no question that there is an intimate relation between the physical characters and the constitutional vigor of fowls. From appearance alone a careful observer can pick out weak fowls from strong ones. None but strong ones should be used for breeding, because the transmission of strong points from parent to offspring is more likely to result favorably both in the hatchability of the eggs, the livability of the chicks and the strong constitution of the offspring than where weak chickens are used as parents. For these reasons a system of the most rigid selection should be practiced in every poultry yard. This selection should begin as soon as chicks are hatched and continue until the breeding pens are made up.

As soon as weakness is observed in growing chicks, these chicks should be separated so there can be no possible mixing of them with the breeding stock and so they may be disposed of through

market channels. The production of a larger proportion of eggs of strong, healthy chicks, and consequently a greater net profit, depends very largely upon the selection. This question of selection is one of the most important the poultryman has to answer. The reason is that more is being required of the flock today than formerly. We are demanding more of the hen in proportion to her live weight than from any other domestic animal. Because of this, fowls frequently break down or show lack of vigor in their offspring. Much of the infertility, the low-hatching power of eggs, weakness of chicks and mortality in full-grown stock is traceable to the impaired constitution of the parent fowls, due in a large measure to the strain of producing abundant eggs under intensive methods. Hens in commercial poultry yards are expected to lay about five times their weight of eggs annually. This means an egg at least every third day, or perhaps even every second day.

According to Dr. W. H. Jordan, of the New York state experiment station, a Leghorn fowl weighing  $3\frac{1}{2}$  pounds and laying 200 eggs which weigh 25 pounds may be compared with a Jersey cow weighing 1,000 pounds and giving 7,000 pounds of milk containing 14% of solids during the year. If the dry matter of the hen be compared with that of the eggs there will be  $5\frac{1}{2}$  times as much in the eggs as in her whole body. In the cow's body the weight of the dry matter to that in the milk is 1 to 2.9. Hence the hen does twice as well as the cow upon the dry-matter basis. She is therefore "the most efficient transformer of raw material into a finished product that there is on the farm." In her physiological activity she stands in a class by herself.

It is very evident that strong and weak fowls are found in nearly all flocks, and strong and weak strains in all varieties of poultry. This fact is so well recognized that it is not safe to judge of the merits of any variety without knowing how it has been bred and handled. Variation in constitutional vigor applies equally to all domestic fowls kept under unnatural or forced conditions. No matter how important it may be to secure a variety or strain with certain attributes of size or productive capacity, it is far more important to have fowls of strong constitution with appetites to consume large quantities of food and digestive power to assimilate well. Pure-bred fowls of strong constitutional vigor are especially desired.

### DANGER OF PRODUCTIVENESS

Impaired vitality of flocks may be due to increased productiveness, in-and-in-breeding without regard to vigor, use of pullets instead of hens for breeding, heavy feeding to induce large egg yields in fall and winter when egg production is not seasonable, crowding of breeding stock in limited quarters, lack of exercise for the breeding stock, carelessness in methods of keeping eggs for hatching, defective systems of incubation, brooding and rearing, especially under crowded conditions, violation of sanitary requisites and failure to select breeding stock of recognized vigor.

As to increased productiveness, it is evident that there must be a proportionate increase in the physical strength to make the fowl thrive while meeting the demand for increased consumption of food and heavier production of eggs. The practice of in-and-

in-breeding which is often adopted to develop high production or other qualities can be followed with success only when special attention is given to mating strong individuals. Breeders frequently lack the courage to sacrifice weak individuals which show other desirable qualities. Pullets which have produced large quantities of eggs in fall and winter may have lowered their vitality before the breeding season begins, so that the breeder will be running a risk to use such fowls as parents. By using these birds and their progeny for a succession of generations, it is thought there may be a tendency to shorten the natural life of the race of fowls and also lower the vigor. When breeding from mature fowls two or more years old, the tendency should be to increase longevity and vitality.

Trouble is likely to arise from heavy feeding for large egg yield during fall and winter, because egg production is not natural at that season. Hens or pullets so fed should not be expected to produce eggs for hatching. Fowls under normal and natural conditions, when allowed to stand most of the year storing up energy for reproduction, are almost sure to do far better. For breeding purposes they should be selected long before the breeding season, fed and housed without regard to market, but with an eye single to the production of numerous hatchable eggs during the natural mating season.

There is no question that congestion or crowding of the breeding stock is one of the most serious causes of impaired vitality. Fowls kept in large numbers should be on extensive farms rather than in crowded quarters. Land occupied by fowls should also be used for grass, grain and fruit crops; the poultry department being incidental. This

method will provide ample free range and prevent soil contamination. No matter how the fowls are kept there should be extremely careful grading as to vigor and size so as to reduce the contest as much as possible between the physically strong and the physically weak. Where crowding is practiced overfeeding is common. Plenty to eat and little to do is one of the surest and strongest factors for producing infertile eggs and weak chicks. Plenty of deep litter for the fowls to scratch in and whole grain scattered in it to encourage exercise are used; preventing or reducing the dangers from overfeeding, and, to a certain extent, taking the place of free range and exercise in the open air.

Numerous experiments have shown that the fertility and hatchability of eggs can be injured or lost by wrong methods of keeping eggs for hatching, and it is presumed that chicks hatched from poorly kept eggs have a vitality inferior to those hatched from eggs properly kept. As a general rule, eggs should be kept in a cool place 45 to 55 degrees, turned daily and not set when more than a week old. Defective incubation, natural or artificial, is also likely to impair vitality. The artificial methods are probably more often at fault than natural ones; poor operators may fail with good machines; good operators may fail with poor ones; and then, of course, there is the combination of poor machines and poor operators. All three combinations will produce poor chicks. Good machines, however, and good operators can be relied upon to produce good results from properly managed eggs laid by vigorous stock. It is essential that chicks be raised in a healthy environment upon the best rations and with free range. They need not be

forced on rich food with lack of exercise, but a rapid development is highly desirable. Excessive coarse feed which is slow to assimilate is likely to retard and stunt growth.

### VALUE OF VIGOROUS PARENTS

To maintain or increase the physical vigor of a flock none but the most vigorous parents should be used as breeders. The chicks of inferior consti-

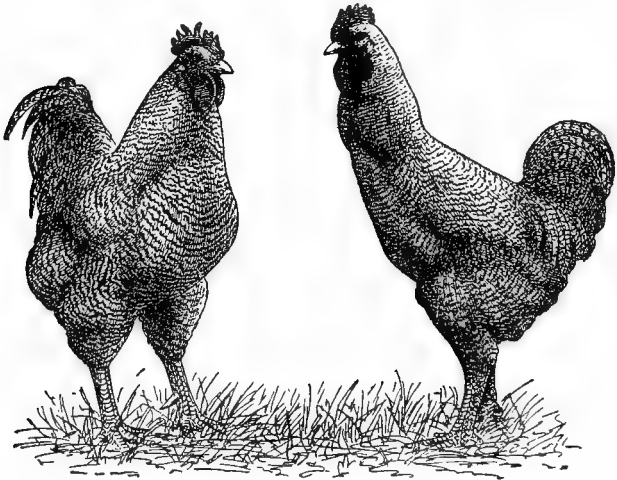

ROBUST AND INFERIOR TYPES OF FOWLS

tution should be removed. Chicks conspicuously weak upon hatching should be destroyed at once, or should be marked in such a way that there will be no risk of their being selected should they seem to overcome their physical weaknesses. They should go to market at the earliest opportunity; for though



they may seem to overcome their weaknesses there is the risk of transmission to progeny. Even when such a move may demand the disposal of an entire flock and the commencement with new blood, this will be found desirable and economical in the end. One of the best ways to mark such fowls is with aniline dye. The color will remain until new feathers come in. According to Prof. J. E. Rice the more important characteristics which distinguish weak from strong fowls are as follows:

“The actions of a fowl probably best indicate the physical condition. The physically weak is inactive and dopey and more likely to squat than to stand. It does not scratch or forage actively. It is the last to get off the perch in the morning and the first to go to roost at night, and frequently is found on the perch during the day.

“The loudness and the frequency of the crow of the male or the song or cackle of the female is a remarkable indication of strength. The weak fowl seldom crows or sings and is less likely to do so in the presence of a strong individual of the same sex. Gallantry on the part of the male is shown in generosity and consideration toward the females as indicated by his calling them and giving them the tenderest morsels to eat. This is one of the surest indications of physical vigor on the part of the male. The shape of the body is closely related to the health and physical vigor of the individual. The deep, thick, compact body with large fluff shows greater vigor than the slender, long-jointed, more delicate body of the same variety. This is particularly noticeable in comparing strong and weak males. (See cut on preceding page.)

“There is an interesting correlation between the

various parts of the fowl. This is one of the safest guides in selecting fowls on the basis of vigor. For example, a fowl of low vitality is likely to have a long, thin beak and head; long, thin neck; long, slender body; long, thin thighs and shanks; and long, thin toes. The reverse is true of the physically strong. To examine a fowl in detail for physical vigor we may begin at the head. This in the physically strong should be medium to large, short and broad, while in the physically weak it is more likely to be long, flat and thin, with long, flat beak, producing a crow-headed appearance.

“A strong fowl should have a medium to large, bright red comb and wattles. The fowl carries its health certificate on top of its head. The eye is the mirror of the body. It shows unmistakably the condition of health and disease. A fowl in good health should be of a bright color, round eye, which should stand out prominently. The lids should not droop, giving the appearance of a snake or a turtle eye. The size and the way the tail is carried is also an indication of vigor. A fowl having a strong constitution has a full development of tail feathers. These normally are carried erect. A fowl of the same variety having a weak constitution, especially if suffering from disease, is likely to have tail feathers less developed, and to carry them on one side, or drooping. This is more apparent when the weak fowl is suffering from fright, which usually will be the case when placed in the presence of the strong. The breast should be round and full, the keel bone well covered with meat. This indicates good muscular development. A fowl shows ill-health and weakness quickly and unmistakably by a shrinking away of the muscles about the keel.

"The shanks are a conspicuous indication of the strength of a fowl. They should be of pronounced color characteristic of the variety, large and plump as compared with the faded out, thin shanks of a fowl of low vitality. Cold shanks are a very common accompaniment of low vitality. The quantity, brilliancy and nature of the plumage are very reliable indications of constitutional vigor. The feathers of a fowl of low vitality grow small. They are likely to be dull and ruffled as compared with the close-fitting, smooth, fully developed bright plumage of the vigorous fowl. The color pigment, so pronounced in the feathers of the brilliantly colored, does not develop to perfection with physically weak fowls. Fowls that lack vigor do not, as a rule, have the necessary surplus fat in their bodies to supply the gland at the base of the tail. This gland furnishes the material to oil the plumage.

"The appetite is also a good indication of vigor. A vigorous and strong fowl consumes large quantities of food. It is usually found with a full crop if suitable food is available. A fowl constitutionally weak seldom carries more than a small amount of food in the crop no matter how much may be accessible or how attractive it may be.

"In breeding fowls for high egg production, we must develop a sexual character. It is the first stage of reproduction. Hence if we would succeed in increasing production we must be skillful in recognizing and in selecting only individuals which are physically and sexually vigorous for a breeding flock. When either physically or sexually weak fowls are discovered, they should be removed from the breeding flocks. Any single evidence of physical weakness alone may not necessarily be conclusive,

but a combination of several weak characteristics is absolutely reliable."

### EXPERIMENTS PROVE THEORY

To prove the truth of the foregoing statements and to show that it pays to select breeding fowls according to their vigor, Professor Rice tried three experiments at the New York state agricultural college. In one, 50 White Leghorn chickens were selected when about the size of quail. They were divided into two lots of 25 each. In the second experiment 50 others in two lots of 25 were selected in the fall and placed in winter quarters. In the third, 50 Barred Plymouth Rock pullets were divided in the fall into two pens. In each experiment there was one flock of weaker vitality than that of the other of the same variety. These contrasts were not conspicuous to the casual observer, but could be recognized by any one familiar with the characteristics mentioned. During a full year records were kept of the food consumed, the eggs produced, the mortality and health of the fowls, the fertility and hatching power of the eggs and growth of chicks. In all three experiments the fowls were kept under the same conditions as to feeding and housing. An equal number of eggs from each flock in each experiment was carefully selected and placed in the same incubator, hatched in pedigree trays, the chicks leg-banded, placed in the same brooder, fed together and allowed to run in the same corn field during the summer. They were weighed at frequent intervals, newly leg-banded as they grew, and in the fall after weighing were placed in winter quarters.

So far as records of production are concerned, the fowls selected in the spring, when chicks apparently overcame their weakness by reason of special care, gave practically the same results in production during the first year as did their sisters chosen at the same time for vigor and kept without further selection. In the other two experiments, however, in which the selections were made in the fall the contrast between weak and strong flocks was very marked, both as to the number of eggs laid, the profits for each fowl, the fertility and hatching power of the eggs and the growth of the chicks. The net results of the experiments, however, show that fowls in the three strong flocks averaged about one dozen more eggs in a year than those in the weak flocks, and produced a profit of 41 cents a hen over and above the cost of food more than the fowls in the weak flocks.

Eggs from the strong hens averaged nearly 11% greater fertility and 4% better hatching power than eggs from the weaker ones. But the most striking contrast was shown in the difference in the size and appearance of the pullets reared from the strong and from the weak flocks of fall-selected Barred Plymouth Rock fowls. The results for the White Leghorn were nearly as striking; the chickens from the strong stock averaged over  $\frac{1}{2}$  pound more than the pullets hatched at the same time from the low vitality stock. They had also larger, deeper bodies, larger bright red combs and appeared to be at least four or five weeks older.

### REQUISITES OF THE TRAP NEST

To be thoroughly practical a trap nest must be constructed so it will be impossible for a hen to

enter without closing and locking the nest itself. The trigger, spring or treddle must never fail. These must be so sensitive that even the lightest hen as well as the heaviest will make them work. It must always lock and remain locked after it has been closed, so a second hen cannot enter while the first one is on. Preferably it should be built with two

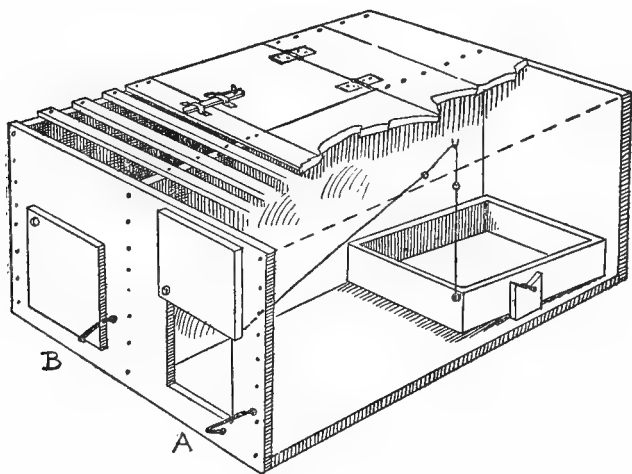

DOUBLE TRAP NEST

When the hen steps on the nest proper the cord pulls a pin and the door falls shut.

compartments—the rear containing the nest itself and the front a vestibule in which the hen may stand after the egg is laid and before she is taken out. Without a front compartment there is danger that the hen will break the egg. There should be no danger, however, that the hen will lay in the front compartment without causing the trap to

operate. Many trap nests now on the market are defective in this way. Some hens seem to prefer the front compartment to the apparently more comfortable rear one. Unless the trap closes it will be impossible to secure a proper record of the egg.

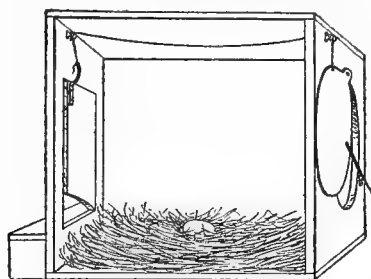

RELEASING TRAP NEST

Door at right closes after hen. Sets itself when hen escapes through rear door into another yard.

Simplicity of construction and operation are highly desirable. Many nests now on the market are so complicated that it would be impossible to operate and keep them in repair when working a large flock. In order to be effective, the nests, if

used on a large scale and constantly, should be so easily tended as to take a minimum amount of time to empty and re-set. At best, trap nesting is expen-

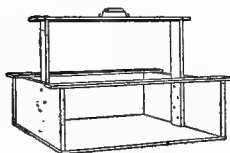

FRAME

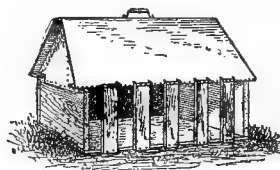

COOP

Canvas or paper. Top and gable on light frame make this coop easy to carry.

sive; hence the question of labor must be reduced as much as possible. Trap nests should always be durable and unlikely to get out of order.

## KIND OF FOWL TO KEEP

The choice of a variety of fowl for any purpose depends largely upon the preference of the poultry raiser, the purpose sought and the locality. Some people prefer white fowls, some black, some buff, some mottled; others have as decided preferences for still different kinds. The color of plumage, the size of bird and all other considerations are individual. Such being the case, no discussion will be given here as to mere preferences. The points that will be emphasized are flesh and egg production in utility points.

Probably the most popular breeds for table purposes are the Barred Plymouth Rock, the White Wyandotte, the Rhode Island Red and the Light Brahma. These varieties are all large, and the first three are at almost any age excellent for the table. The last one is slower growing, but attains the largest size of all. These remarks must be modified by saying that much depends upon proper management. Among other table breeds are various varieties of Plymouth Rock, notably the White and the Buff. Then, too, there is the Houdan, the Faverolle, the La Fleche—all French breeds. The Dorking and the Orpington, English varieties; the Langshan and the Cochin, Asiatic fowls. These are all more or less popular, but have never gained the wide favor in America that the first four have. The only one of the last mentioned that has been gaining very rapidly in popular estimation is the Orpington. This group of varieties has not been long enough in this country to supplant our principal favorites. It may be taken as a general proposition that any variety of poultry, well managed, will produce as



desirable poultry flesh as any other, though the quantity may not be as great in some cases as in others.

As to egg production, the Mediterranean class is well in the lead, and among the varieties of this group the White Leghorn stands probably first, with the Brown Leghorn and the Minorca as close rivals. Doubtless the White Leghorn is the most widely popular among egg farmers, especially in the East and in California. Though it is reputed as an excellent summer layer, it is also good when properly managed for winter egg production. The same remark applies to other breeds of the Mediterranean group. Among other noted layers are the Ancona, the various Hamburg and Polish varieties, but these have not become widely popular in the United States. The eggs of the last two are rather small. The Black Spanish, famous more than a generation ago both as a table fowl and a prolific layer, is not as popular now because it has been badly managed. Good management should make it good in both respects again, but for the egg producer this is a venture not to be recommended.

For general farm use, probably the Barred Plymouth Rock, the Wyandotte and the Rhode Island Red are the favorites, all breeds considered. These breeds when bred for utility purposes will be found useful not only for table purposes but for egg production. Whichever breed is selected, the poultry raiser should choose only those specimens that have been bred for utility purposes and true to its variety characteristics. The initial cost is not so great that one cannot afford to pay for good breeding and thus encourage himself to take the keenest kind of interest in his poultry. With poor stock, interest is

likely to flag. Too much emphasis cannot be placed on the fact that there is a satisfaction which comes from the knowledge of possession of good stock that cannot be gained in any other way. It is needless to say that stock should be bought from breeders who have their reputation at stake, and that it is in the highest degree desirable not to mix strains, but to purchase new blood from one breeder from time to time so as to prevent the breaking up of strains and the loss of valuable characteristics, especially with respect to egg laying. Probably it is most economical in the spring to buy eggs for hatching and in the fall to purchase cockerels and pullets. Above all things, it is desirable to keep only one breed at a time on the farm.

In raising poultry for market or egg production the purchase of cull fowls is not necessarily undesirable. Culls are frequently fowls that show a defect only in plumage or form, and are not disqualified for anything except the show room. It is highly undesirable to do any cross breeding, because the ideals of different breeders are often so radically unlike that the cross secures few of the best points of either parent. This subject is already evident from the discussion on breeding.

### THE BARRED PLYMOUTH ROCK

is undoubtedly more extensively bred and used for general utility purposes than any other breed. It has won its way in popular favor strictly on its merit. Some qualifications which make it so desirable for farm purposes are: Size, which is the happy medium between the heavy Asiatic and the light-weight breeds. The standard weights are **cock,**

9½ pounds; hen, 7½ pounds; cockerel, 8 pounds; pullet, 6½ pounds. The growing chicks possess a characteristic rarely found in such desirable perfection in any other breed. When properly managed they are in splendid table condition from the time they are eight weeks old up to maturity. It is also claimed the old fowls easily get in fat condition and are superior in quality to other breeds at the same age. The hens are excellent mothers, and will often recommence laying in eight weeks, and still continue attentively to mother their broods. They are good winter layers; and it is the winter eggs that make poultry keeping pay. The eggs are of good size and are classed as brown. The breed is a vigorous one, prolific, and the percentage of fertility of the egg is always high. The chicks are sprightly and strong from the very start.

Pullets will often commence egg laying when they are six months old; even those that are hatched late in the season will do so when their six months end as late as December, providing, of course, they have been properly cared for. One of the excellent features about their laying is that when they commence they make a business of it. They do not, like some of the Asiatics, lay less than a dozen eggs, and then persist in sitting.

## LEGHORN FOWLS

For the production of large numbers of eggs, the White Leghorn is most popular the country over. The breed is a hardy one of small to medium size. The weights seldom exceed seven pounds unless the fowls are specially bred for size. Probably the generality of people succeed better in getting good

egg yield from this breed than from fowls of other breeds. The reasons are because of the activity of the fowls and because the Leghorn is hardier than other varieties of the Mediterranean class. Then, too, the fowls are less likely to become fat, even when over-fed, than are the fowls of the American and the Asiatic breeds. The cockerels make excellent broilers, especially when the poultryman has aimed for size in his breeding, but where fowls for roasting are desired the Leghorn is not as conspicuous a success as the Plymouth Rock, the Rhode Island Red, the Wyandotte, the Orpington and the Asiatic breeds. Like its relative, the Brown Leghorn, the White variety has two sub-varieties, namely, Single Comb and Rose Comb. Probably the Single Comb is the more popular of the two.

Besides the White and the Brown Leghorn, there are other breeds of this group—the Black, the Buff, the Dominique, the Silver Duckwing, etc.—but these are much less popular than the White and the Brown. They are all characterized more or less as egg producers and as good foragers. Because of their active habits, they do best on wide range. Where such cannot be given the fowls must have abundant opportunity to take exercise.

### LIGHT BRAHMA

The Light Brahma is without exception the largest fowl raised. It is most noted as a meat producer, mainly because of its size, but also because it is probably the most popular variety for producing South Shore Soft Roasters for the Boston market. It is a fairly good layer of large, brown eggs, and though noted more for its meat, it will

yield under proper management a goodly number of eggs while prices are highest. The standard weight of the cock is 12 pounds, that of the hen 9½ pounds. The hens are good sitters and mothers, but are rather heavy and clumsy. They are often used for hatching duck, turkey and goose eggs, because they can cover more than hens of ordinary size.

Brahma chicks are slow in developing their feathers, but in spite of this they are good growers and gain weight more rapidly than many other varieties fed equally well. As farm fowls they are not as successful as many of the other varieties, because they are not quick enough to be good insect catchers and are not otherwise as good foragers as most popular farm breeds. For this reason they must be fed more carefully. These characteristics of slowness and weight favor their being kept in confinement. A low fence is sufficient. Their color is mainly white, though the hackle, the tail and the flight feathers of the wing are mainly black. They have pea combs and red ear lobes, yellow skin and legs, the shanks feathered down to the ground.

## WYANDOTTES

The Wyandotte has a half dozen well-known varieties. Among these, probably the most popular are the White, the Golden and the Silver, though Buff and Black Wyandottes are also well known. Probably the most important is the White, which, in the leading poultry shows, is a close second to the Barred Plymouth Rock. Not only is this so in the poultry show, but throughout the country the White Wyandotte and the Rhode Island Red are

unquestionably the strongest competitors in popular favor that the Plymouth Rock has. The Wyandotte breed as a whole is a hardy, general purpose breed which lays brown eggs; the hens make good sitters and mothers. The recognized standard weights are  $8\frac{1}{2}$  pounds for the cock and  $6\frac{1}{2}$  for the hen, but greater weights than these are common. Like the Plymouth Rock, the fowls are good foragers, good layers and good table birds. They are characterized by compact bodies with yellow skin, and on this account are highly popular in the markets as table fowls.

### RHODE ISLAND RED

The two sub-varieties of the Rhode Island Red, the Rose Comb and the Single Comb, are almost equally popular. The breed, as its name implies, originated in New England, where its hardiness, its brown eggs and its general utility have appealed to popular taste. The hens are good sitters and mothers. The breed is noted for its ability to forage and also for the ease with which it may be kept in confinement. The sizes compare with those of its chief rivals, the Plymouth Rock and the Wyandotte. The color is a peculiar reddish buff with mixtures of black, more especially in the wings and tails. It is claimed that the chicks mature more rapidly than either Wyandotte or Plymouth Rock chicks, and that they make more meaty broilers at the same age. This is probably due more to management than to the breed itself. Some people consider the Rhode Island Red inferior to other American varieties as table fowls, but superior as layers, more especially during the winter.

## OTHER BREEDS

The Hamburg varieties are good layers of small eggs, but, like the Polish varieties, are less seen on the farm than among fanciers.

The Polish varieties are all excellent layers. They are not only small, but they lay small eggs. They are especially fanciers' fowls and are rarely seen on farms except as pets.

Among the less widely known American breeds the Mottled and the Black Java are popular in some sections. They compare in size with the Plymouth Rock, and are good both for table and for egg laying.

The American Dominique was at one time very popular as a general purpose fowl because of its hardiness. The Barred Plymouth Rock, which it somewhat resembles, has replaced it to a very large extent.

Houdans are French fowls noted for their flesh. They are good layers, non-sitters and excellent where there is no danger of attacks from hawks and other birds of prey. Their crests are an objection where hawks are to be feared.

The White Wonder is a brown egg laying, hardy, general-purpose breed somewhat larger than the White Wyandotte which it resembles, except that it has feathers on the shanks. The variety is popular in some sections as a farm fowl because of its hardiness, ability to forage and fair prolificacy.

The Langshan is a fairly hardy Asiatic fowl which lays dark brown eggs in moderate abundance. Probably this is the best laying variety of the Asiatic class. The standard weight of the cock is 10 pounds and that of the hen 7. The hens are good sitters and mothers, less clumsy than other Asiatic

fowls. The more popular variety of Langshan is the black.

The Dorking has several well-known varieties, the most popular are White, Silver Grey and Colored. This group is noted for the small number of eggs the hens lay and for persistent sitting. In England they have long been the leading table fowl. In America they are less popular because they do not lay enough eggs. This is due principally to the methods employed in breeding.

The Dark Brahma resembles the Light Brahma somewhat in size, but not in plumage, which, as its name implies, is dark, with considerable penciling as in the Partridge varieties of Cochin, Wyandotte, etc. The breed is not quite so large as the Light Brahma, but it is equally hardy. The hens are fair layers, sitters and mothers, but like their cousins are rather awkward on the nest and with chicks. Other remarks concerning the Light Brahma apply more or less generally to this breed.

The Cochins, like the Brahmas, are heavy breeds of the Asiatic class. There are several varieties, viz.: The Buff, the Partridge and the White. They all have profusely feathered legs, are very hardy, very docile but very determined sitters. On this account they are not popular as farm fowls. Like the Brahmas they are poor foragers and must be fed liberally. Most people consider them inferior to the Brahma as layers and as table fowls, but when well bred and managed they make both good roasters and layers.

The Minorca has two leading varieties, viz.: Black and White. The former with two sub-varieties, the Rose Comb and the Single Comb. These are fairly hardy fowls. The hens rarely sit.



They lay particularly large white eggs in abundance under good management, but these eggs are mainly produced when prices are low. The breed is especially valuable for the home flock, largely because of the size and high quality of the eggs. Like the Leghorns the Minorcas are good foragers, but of a reputed nervous disposition. This nervousness, however, is due more to the poultryman than to anything else; even the docile Cochin may be made nervous by bad management.

The Orpington has several varieties. It is an English breed which has been introduced in America only a short time, but during this period has become very popular, mainly because of the extensive advertising it has had. Among its principal varieties are Buff, Black and White. Some of the varieties are sub-divided into Single and Rose Comb. The Black and the Buff are most widely popular in America. The breed is of large size and compares with the Plymouth Rock, the Wyandotte and the Rhode Island Red for the table. The hens are good layers of rather large eggs, good sitters and mothers. Wherever tried the breed has proved acceptable.

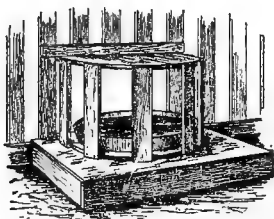

PROTECTED WATER PAN

## CHAPTER VII

### Feeding and Feeds

Next to breeding and housing, the feeding of fowls is perhaps the most important essential in poultry raising. Poultry keepers, as a rule, do not realize the importance of good feed. Others place

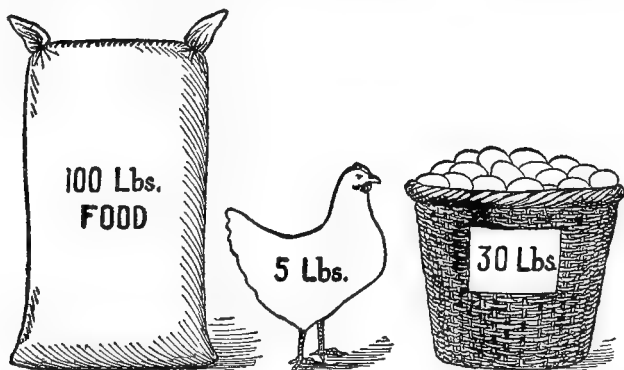

#### RAW MATERIAL, EGG MACHINE AND FINISHED PRODUCT

The Oregon experiment station thus graphically teaches what a utility fowl does.

too much responsibility upon the feed and feeding. Let it be remembered that no amount and no quality of feed or anything else will make all hens lay or all poultry profitable. The factor of individuality must be considered. Some hens will lay 150 to 200 eggs in a year and others treated the same will not lay an egg. On the other hand, no

amount of good feeding will make up for lack of good breeding or good housing.

It is now recognized that food affects the quality of eggs. While it is doubtful if the hen could lay eggs wholly unfit for food, it has been shown by experiment that the quality of eggs can be injured, especially in flavor. Onions and fish have both been found to give an unpleasant flavor to eggs when fed to excess; so will beef scrap. Doubtless other feeds will do the same. It is not necessary that these feeds should be discarded, because when fed in normal amounts they will not perceptibly flavor the eggs. When hens have been starved for want of green food or animal food and then get a chance to eat to excess they will produce unpleasant results in the eggs. This shows that hens put into the eggs what they find in the feed. Hence the importance of supplying good, wholesome feed at all times.

Skillful feeders can vary the shade of yellow in the yolk of the egg by the feeding, but not alter the color of the shell. Dried alfalfa has been found to produce eggs with good yolk color. Sugar beets produce a pale tint. Kale makes a good yellow. Some people hold that yellow corn will color the yolk, but this has not been credibly verified. Pale yolks indicate that hens are not getting sufficient green feed. Probably clover, vetch, rape, grass and other green feeds will all produce yellow yolks.

### **FEED AFFECTS QUANTITY OF EGGS**

There is no question that food affects the quantity of eggs. Good feeding will help to make good hens productive. In one instance a pen of four fowls laid over 800 eggs in one year. Another pen of full

sisters, but fed differently, laid only about 530. The difference in the feeding is accountable. It has also been shown that feeding will influence the size of the eggs. Neither the hens nor the breed are responsible.

A correct study of feeds and feeding must necessarily include cost and profit as well as composition of the feeds themselves.

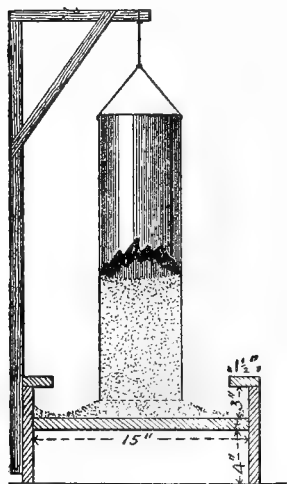

STOVE PIPE HOPPER

Simple and convenient.  
May be hung from ceiling  
or as shown.

Though a ration may give good results in a yield of eggs, it may not be profitable because of its high cost. It is not essential to use any special brand or kind of feed, nor is it necessary to pay more for a feed than for the food of the home table. Many rations are impracticable, simply because they are too costly. Knowledge of poultry feeding has not gone far enough for anyone to say that certain results can be secured from certain feeds or rations, yet much

valuable information has been secured by experimental feeding, and through the experience of practical poultry keepers. The chemist classifies the composition of feeds into protein, fat, carbohydrates and ash constituents. These are all contained in all feeds, but in varying proportion. The chemist also tells us that eggs contain the same constituents, but with a larger proportion of pro-

tein. Eggs are more valuable as a market commodity than grain. A pound may be worth from 10 to 25 cents in the market, whereas a pound of wheat would rarely exceed two cents in market value. The hen may convert this comparatively cheap wheat into a product of much higher value. For this reason she may be looked upon as a manufactory. Still she can utilize at least a pound of water for every pound of wheat she puts into the eggs, and thus the poultryman can sell water for a good price.

### WHAT HENS PUT IN EGGS

It must be remembered that the hen puts into the egg what the poultryman gives her. No one can say definitely what kind or combination of feed will give best results in good yield. The chemist does not tell and practical feeders do not. Nothing but experimental work can solve this problem. It is known, however, that eggs have a certain composition and to produce them the hen must have certain elements in her feed. The composition of the egg varies scarcely at all. The hen must, therefore, have the proper feeds to supply the demand of the egg. If she cannot get these she will stop laying. If fed exclusively on wheat she may eat a quarter of a pound a day. Of this she will probably consume three ounces to supply the demands of her body, thus leaving 1 ounce with which to make eggs. In this ounce there is about one-tenth of an ounce of protein. Supposing that this were all digested—which is never the case—there will not be enough protein to make an egg, because each egg contains about one-quarter ounce of protein.

A hen so fed would require two or three days to secure enough protein to make an egg.

Eggs contain also one-quarter ounce of ash, mostly in the shell. An ounce of wheat contains less than one-tenth as much lime and other ash constituents as the egg contains. Eggs also contain fat, less than one-quarter of an ounce; wheat contains three-quarters of an ounce. When fed as above hens would not get egg constituents in proper proportions to make an egg a day. It is just as poor economy to feed corn or any other feed exclusively. The rations must be balanced. If left to herself the hen would secure what she needs if such raw material were available.

The following suggestions will prove helpful: The hen first supplies the needs of her body. This demands constant rebuilding because of the continual wearing out or breaking down of animal tissue. The poultryman must therefore feed more than enough to supply this waste. He must feed a growing ration to the chicks and other young fowls. He must compound rations to insure health and vitality and then supply enough raw material of the various kinds for the hen to make eggs. Eggs are made from surplus food. After the hen has supplied her body wastes, she may devote the balance to egg production. It is therefore poor economy to feed just enough to keep the hen in health and vigor. Heavy feeding, however, does not necessarily mean heavy egg yield. While the heavy layer must consume abundant food, the manner of feeding and the kind of feed must be reckoned because the efficiency of feed depends largely upon the kind of the feed itself and the skill of feeding.

Poultry feeds contain various quantities of protein, carbohydrates, fat and water. The water is frequently overlooked by the feeder. Even wheat contains about 10% ; clover and alfalfa 75% and in skimmed milk there is about 90%. No poultryman should pay more for water in the feed than as water from his well or spring. Grain feeds are also deficient in ash. Hence the hen must secure grit, oyster shell, etc., to supply this lack. The ash, therefore, need not be considered of high value because of its cheap source. Carbohydrates and fat furnish the fuel necessary to keep the body warm. It is necessary for the hen to be warm in order to produce eggs. Unless warm and energetic she cannot digest the food as well.

As a rule poultry feeds contain larger percentages of carbohydrates and fat than are required for best results in egg production. Usually they are deficient in protein, which is the most valuable constituent. This substance makes the lean meat and the muscle and a large percentage of the egg, especially the white. The value of the feed must be determined largely by the percentage of protein it contains. A high price, therefore, should not be paid for feed unless this has a high percentage of protein. In general feeds may be considered expensive or cheap in proportion as they contain small or large proportions of protein.

In studying feeds digestibility must be considered. Composition does not necessarily indicate the true value of feeds, because these may not be digestible. The digestibility of poultry feeds has not been studied sufficiently. There are considerable difficulties in the way. Probably, however, these studies will be made in the future and better

systems of feeding will be worked out. So far the chemical composition of feeds and the analogies between poultry feeding and animal feeding are the only guides for working out balanced rations for poultry.

In the table given below Prof. James Dryden, of Oregon, shows the composition of feeds commonly given to poultry:

### Percentage Composition of Feeds

KIND OF FEED	Water	Ash	Protein	Carbohy- drates	Fat
Wheat.....	10.5	1.8	11.9	73.7	2.1
Corn .....	10.9	1.5	10.5	71.7	5.4
Oats .....	11.0	3.0	11.8	69.2	5.0
Peas .....	10.5	2.6	20.2	65.5	1.8
Barley.....	10.9	2.4	12.4	72.5	1.8
Wheat bran.....	11.67	5.18	14.5	65.5	3.6
Wheat middlings.....	11.8	2.8	15.22	65.7	4.5
Sunflower .....	12.8	2.1	9.1	51.3	21.2
Linseed meal (N.P.)*.....	9.9	5.6	35.9	45.6	3.0
Gluten meal .....	8.1	1.0	28.3	51.9	10.7
Brewers' grains, dried.....	8.0	3.4	24.1	57.8	6.7
<b>Alfalfa .....</b>	<b>71.8</b>	<b>2.7</b>	<b>4.8</b>	<b>19.7</b>	<b>1.0</b>
Clover, red .....	80.9	1.7	3.1	13.6	.7
Kale.....	88.2	1.82	2.57	6.79	.6
Vetch .....	69.2	2.7	3.76	14.22	.49
Rape .....	85.7	2.0	2.4	9.3	.6
Mangel-wurzels.....	91.2	1.0	1.4	1.2	.2
Cabbage.....	90.5	1.4	2.4	5.40	.4
Skim milk .....	90.6	0.7	3.3	5.3	.1
Cottage cheese .....	72.0	1.8	20.9	4.3	.1
Buttermilk .....	90.3	0.7	4.0	4.5	.5
Beef scrap .....	10.7	4.1	66.2	.3	13.7
Cut bones .....	32.8	33.0	28.4	2.5	36.6
Dried blood.....	9.95	3.68	72.0	1.68	3.15

\*New Process.

### NUTRITIVE RATIO

What is called the nutritive ratio is the proportion existing between the content of protein and that of fat and heat-producing constituents. To produce eggs, what is called a narrow nutritive ratio should



be fed; that is, a proportion of one part protein to four or five of carbohydrates and fat. In figuring the ratio the fat is multiplied by  $2\frac{1}{4}$ , because 1 pound is estimated to be equivalent to that amount of carbohydrates. It must be remembered, however, that a nutritive ratio in itself does not necessarily indicate the true value of a ration. Palatability, digestibility and other factors must be reckoned with. Even a proper ratio does not guarantee a good egg yield. The kinds of feed must be considered, and the feeder must be guided by results that indicate the value of the different feeds.

### INDIVIDUAL FEEDS

Wheat is more widely used than any other cereal throughout the country for poultry feeding, because it is safer than most other grain feeds and is relished better by the fowls. Its nearest competitor is corn. Which of these should be fed depends largely upon price. If fed wheat alone, hens would probably lay better than if given corn alone, because the composition of wheat is slightly better for egg production than that of corn, which latter is more favorable for fattening. No one, however, should expect a profit from fowls fed one kind of food to the exclusion of others.

When fed with other feeds, there is dispute as to whether wheat or corn is more economical at the same price a pound. The market price of grain may be taken as a safe basis for selecting wheat and corn. Slightly frosted wheat is of as high feeding value as good wheat and may be substituted for even the highest-priced grade. Shrunken wheat, in fact, has a higher protein content than plump

wheat, and thus a saving may be made by purchasing such grain at reduced prices. Wheat screenings of good quality may also be substituted for high-priced wheat. Bran and middlings are richer in protein than wheat, since there is 14% of protein in bran and about 12% in wheat. Bran is also richer in fat. On these accounts it is usually an economical feed.

Analysis has shown that corn contains more fat-forming elements than wheat. For this reason it

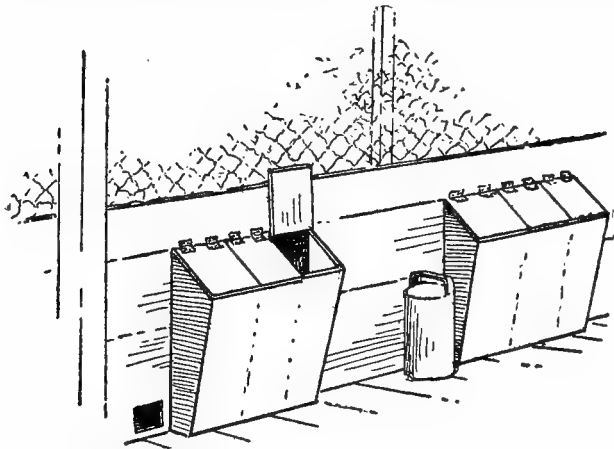

HOPPERS REACHED FROM ALLEY

For quick feeding and watering openings are made in sides of pens; hoppers and fountains placed over them.

became unpopular among poultry feeders. Actual feeding tests, however, show it to be equal to wheat when fed in rational combinations. As good results have been secured in egg production as from wheat. It is, however, an imperfect feed and other feeds

must be used to balance it. Those states which produce the largest quantities of corn are the greatest producers of poultry and eggs, a fact which seems to disprove the notion that corn is not good for poultry.

Oats are not relished by fowls as much as other grains, nor are they worth as much as corn or wheat. The large proportion of hull is an objection since hulls are largely indigestible. Without the hulls oats would be excellent both for laying and fattening. They are not as fattening as corn or wheat and many poultrymen feed them, largely to prevent hens becoming too fat. Great care should be used in selecting oats because of the quality. None but heavy, plump oats should be used. Light oats contain too much hull. Oats furnish a useful variety to the ration. Were hulled oats procurable at reasonable prices, they would probably be better than wheat or corn.

Barley is fed to poultry to a very limited extent. Fowls will usually leave it if they can secure wheat or corn. It may be fed for variety. Peas, where they can be secured at reasonable prices, should be fed extensively because of their richness in protein. They contain twice as much protein as corn and therefore are worth more pound for pound. Where linseed meal can be secured at reasonable prices, it may be profitably fed to poultry because it contains more than 30% protein and is also rich in fat. On this account it is an excellent addition to mash feeds, but must be fed sparingly.

### **IMPORTANCE OF ANIMAL FEEDS**

It is believed that animal food of some sort is necessary to maintain fowls in vigorous health and

productivity, whether the aim be flesh or eggs. Probably no one thing has done more to increase profits than feeding animal food. Scarcity of eggs during winter is largely due to deficiency in this line. Chickens when at liberty during the summer secure abundant animal food in the form of bugs and worms. Something to take the place of this feed is necessary, especially when snow is on the ground. Doubtless lean meat is the best form to feed. It furnishes ample protein. The presence of a little fat does no harm, but may be an advantage. Fresh meat scrap from the butcher's is an excellent egg maker. Butchers often keep bone cutters to sell ground meat and bones to poultrymen. When flocks of 25 hens or more are kept it will then pay to own a bone cutter. These butcher scraps contain large quantities of bone, which the fowls eat very greedily along with the meat. Much of the mineral matter for making shell and other parts of the ash of the egg may be secured through bone.

Skim milk is a good substitute for animal feed if given liberally, but it is not concentrated enough. It contains about 90 per cent water or only about 10 per cent of food. When used as a drink hens will not take enough of it to supply their demand for animal feed. Milk is well used for mixing the wet mashes, by feeding it clabbered, and best in the form of cottage cheese, which is a particularly good form when well made.

A good way to make cottage cheese is to set the dish of skim milk where the temperature will range between 75 and 80 degrees for 18 to 24 hours, by which time the milk will have thickened. It should then be broken up into pieces about the size of peas or smaller. The dish should then be

set in a pail of hot water and the curd stirred until its temperature is 90 or 95, when it should be held at this heat for 15 or 20 minutes without stirring. The contents of the dish should then be poured into a cotton sack and hung up where the whey may drain off. Care must be exercised not to allow the milk to boil. After the whey has drained off a little salt should be added. This cheese will keep in mild weather for a day or two; longer in cool weather.

Doubtless the most convenient form in which to feed animal food is beef scrap, a by-product of the large packing houses. It has been boiled and dried, and as it reaches the poultryman contains meat and bone in varying proportions, but should analyze 50 to 60 per cent protein. It also varies in quality, but should always be light colored, have a meaty flavor and be rather oily to the touch. When boiling water is added to it, it should smell like fresh meat. If a putrid odor is given off it should not be fed.

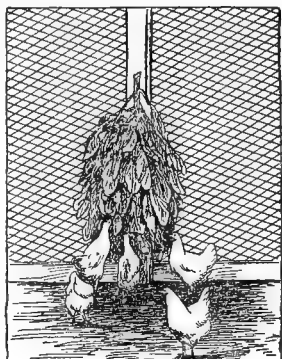

GREEN FEED FREE

Thousand-headed kale;  
hung for hens to peck at.

### GREEN FEED ESSENTIAL

It is essential to the fowls' well being and egg production to have green food every day. Lack is sure to affect egg production unfavorably. Flocks at range can secure abundant green food, but flocks

in yards and in winter quarters must be supplied. It may be fed without stint at all times. Among the best feeds are clover, alfalfa, grass, vetches, pea vines, rape, rye, mangels, kale, cabbages, sugar beets, turnips—in fact anything and everything the hens will eat. During the winter cabbage is specially useful. Root crops are good also. The leaves and broken heads from the hay mow may be steamed if desired. Kale and alfalfa contain especially large amounts of protein and ash. The latter and clover give a good flavor and quality to the eggs; but kale, cabbage, turnip and other plants of the mustard family are likely to impart a slightly disagreeable flavor if fed too abundantly.

According to Prof. J. E. Rice, oats and peas sown together very thinly with a liberal seeding of red clover and a very little rape make a good combination. The oats and peas furnish a rapid growth of green feed. Much of it will get tramped down and some go to seed, but will serve to protect the clover and the rape, which will make good feed late in summer and fall. Three pecks of oats, two of peas, a pound of rape and 5 quarts of red clover seed make a good proportion for sowing an acre. The oats and peas should be first harrowed in deeply, then the clover and rape sown mixed and lightly scratched in with a weeder. The potatoes may be fed for variety boiled and mixed with a mash, but they are not very useful as an egg food. They do better for fattening. Sour apples should not be fed unless sparingly.

### NECESSITY FOR GRIT

At all times chickens need grit. Opinions differ as to the function of grit. One view is that grit is

to grind the food; the other is that grit itself is a food. It is not necessary to argue on this point, but it is necessary to supply the grit. Fowls at liberty usually pick up enough grit except where the land is deficient in sand and gravel. When confined they must have a liberal supply. When gravel is close by the grit question is easily answered. Plenty of sharp sand for the hens to scratch in is all that is necessary. Where gravel is scarce grit must be purchased. It is very cheap. Besides ordinary grit, it is desirable to supply other material for forming the egg shells. Grain does not contain sufficient lime for great egg layers. Oyster and other sea shells are largely used for this purpose, since they are very readily dissolved in the gizzard. Lack of lime or other shell material in the ration often leads to the egg-eating habit among hens, because soft-shelled eggs are laid and broken in the nest.

Charcoal is believed to be useful as a bowel regulator. Most successful poultrymen keep it constantly before the hens. Salt in moderation aids digestion. An ounce or two daily is sufficient for 100 hens. Pepper, which acts as a stimulant, should be fed sparingly. Vigorous hens do not need it.

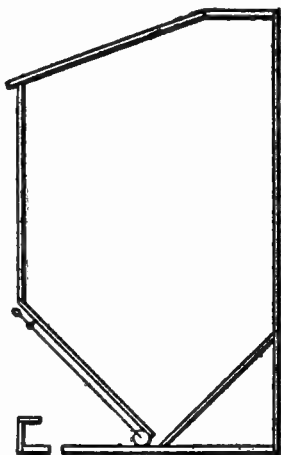

GRIT OR SHELL HOPPER

Hole in floor is for dust to drop through.

The following table prepared by Prof. James Dryden, of the Oregon agricultural college, gives five rations for laying fowls:

Ration No.	1	2	3	4	5
Wheat .....	—	60	30	30	20
Corn .....	60	—	—	10	20
Oats .....	—	—	15	10	10
Bran .....	—	—	10	10	10
Middlings .....	—	—	5	5	5
Linseed meal .....	—	—	—	5	5
Skim milk, or.....	30	30	30	30	30
Cut bones, or.....	12	12	12	12	12
Beef scrap .....	8	8	8	8	8
Alfalfa or clover, or.	15	15	15	15	15
Kale .....	20	20	20	20	20

No. 1 is considered the poorest and No. 5 the best. Corn is the only grain fed in No. 1; wheat in No. 2. This ration is placed ahead of No. 1, because it contains some more protein. Both are deficient in egg-making material, viz.: protein. Either would be an improvement on the average farm ration, but neither is ideal. No. 3, which contains a variety of grains and somewhat more protein, is better than the first two. Nos. 4 and 5 should give abundance of eggs if properly fed. They do not equal the amounts of protein, but No. 5 has more meat-producing food.

It is not definitely known to what extent fat influences egg yield, but it has been found that rations containing plenty of fat give better results than rations with little. Since fowls eat more food during cold than during warm weather, heat-producing foods are more necessary and can be made to



replace the more expensive protein food to a certain extent. More corn should be fed during winter. On this account No. 5 will be found a better winter ration than No. 4. No. 1 will also probably give better results than No. 2 during the winter.

## VALUE OF GOOD METHOD

Unless properly fed no ration, however well balanced or mixed, will give best results. Method of feeding plays an important part. It is necessary that the hen be kept robust. This can best be done by keeping her active. Hens on free range often do better than confined hens solely because of the active life they lead. Poultrymen need not trouble much about the vigor of their hens if the flocks are kept under the free-range system, but when confined in yards great care must be taken to encourage exercise. The lazy hen is the unproductive hen.

Exercise is best supplied by providing a roomy scratching shed covered deeply with even 8 to 12 inches of straw. This straw should be rather dry and whole grain should be scattered in it. There will be no waste; the fowls will find the last kernel. The poultryman's skill will be tested to feed enough at a time without having to feed too often, so as to keep the hens busy most of the day. When too much feed is given at a time the fowls soon become satisfied and will stop eating. It is not essential to keep fowls scratching all the time. The more active breeds, especially Leghorns, do nearly as well when fed from hoppers. When given a yard and a floor they will take sufficient exercise whether forced to scratch for feeding or not. For

the larger, less active breeds, however, it is necessary to force exercise. Experiment has shown that enforced idleness ruins both health and egg production. On the other hand, Leghorns have thrived and even done well though compelled to scratch for every grain they eat. With every breed a happy medium should be struck between idleness and too much exercise. No breed of fowls is injured by having exercise and most breeds profit decidedly. The principal disadvantage of feeding in litter is that grain may become contaminated with the droppings of the fowls, but with proper care in removing the straw as soon as it begins to be soiled this can be largely obviated.

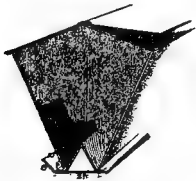

FEED HOPPER

## GRAIN GROUND OR UNGROUND

Poultrymen find that it pays to grind part of the grain feed because this saves energy. Since the energy is furnished by the food there is an actual saving in the food itself, and this can thus be utilized by the fowls for other purposes. Ground grain is more quickly digested and assimilated than whole grain, and hens can manufacture eggs quicker with it. It has been shown that fowls, half of whose grain was ground and moistened, required 20% less feed to produce a dozen eggs than fowls fed on whole grain alone. Fowls, however, enjoy whole grain, therefore probably one-third should be fed in this form. If fed one-half or more of whole grain they would likely lose their appetites and not eat sufficient to meet the demand for heavy egg

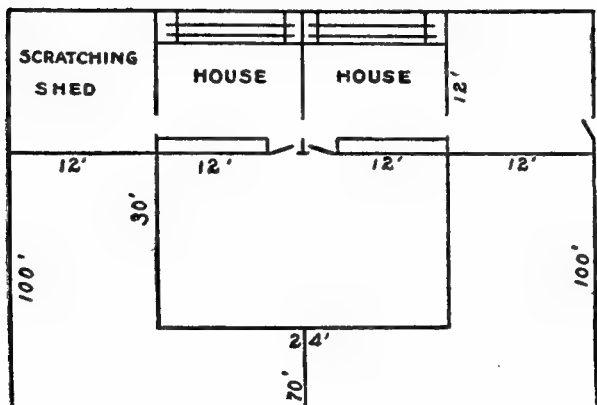

GROUND PLAN OF HOUSE AND YARD

Space-saving arrangement of ground area.

production. If more than a third of the grain is fed ground it should be supplied preferably in the afternoon.

If fed wet mash in the morning, the fowls are likely to gorge themselves and not be as active as

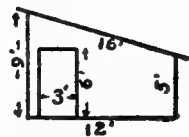
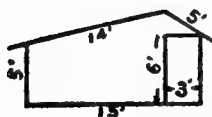
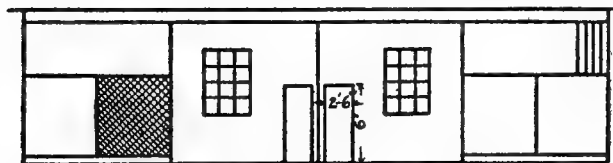

ELEVATIONS OF POULTRY HOUSE

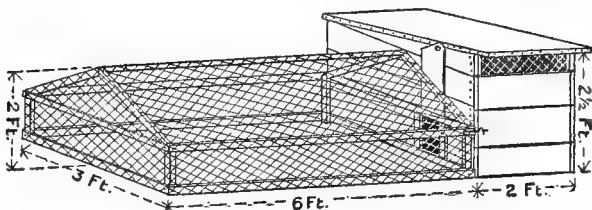

VENTILATED COOP AND DETACHABLE RUN

Slide door closes coop at night.

they should be during the day. Hence a light-grain ration in the litter should be given in the morning. About an hour before going to roost, a good mash feed, followed by a liberal supply of whole grain, will give satisfactory results. Feeding whole grain liberally toward the close of the day in cold weather is a good practice, because the grain will "stick to the ribs" better during the night than will the mash and will help to keep up the heat of the body better.

Another good practice is to scatter enough grain in the litter at night so as to encourage the fowls to scratch for it early in the morning. This practice will also save time in the early morning. Of course, double quantity of grain should be scattered in the evening. When light mashes are fed in the morning, it is best to feed immediately after the fowls come off the roost, but to feed no more than the birds will eat. As to feeding rations 4 and 5 mentioned above,

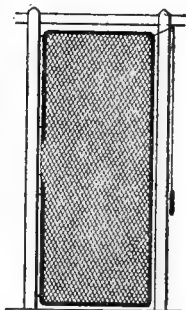

WEIGHTED GATE

Second hand piping frame, covered with netting. L joints. Large staples in wood posts serve as hinges. Pulleys, weight and cord close gate.

the following remarks will be found useful: Mix the ground ingredients with water or skim milk and a little salt until the mass is crumbly. Feed first thing in the morning just what will be eaten up clean in ten minutes. Soon after scatter a little wheat or oats in the straw, just enough to keep the fowls busy till noon. Then scatter some more grain. About an hour before sundown feed wheat or corn, enough to fill the fowls' crops. Fowls on free range will not require such frequent feeding.

### DRY MASH OR WET MASH

Fowls enjoy wet mash more than dry, but dry mash saves labor, since enough may be put in the hopper to last a week. When fed wet, at least one feeding must be given daily. Since fowls eat wet mash more greedily than dry, more care must be exercised to avoid overfeeding. Where skim milk is available the ration may be cheapened by using it to wet the mash. Bran and middlings may be made to take large quantities of milk and thus to balance out and cheapen the ration. Thus it can be made to save more costly feeds. When skillfully fed, wet mash should give better results in egg yield than dry. Cut bone may be fed daily or three times a week, just what the fowls will eat up clean in 10 or 15 minutes. Each hen can use 3 or 4 ounces a week to advantage, though more should be fed during heavy laying and in winter than at other times.

As a rule it does not pay to boil poultry feed, besides, most feeds give better results when fed raw. This does not apply to potatoes and similar starchy feeds, which are improved by boiling.

No radical changes should be made in the ration. A definite plan should be well worked out before

feeding starts and should be adhered to so as to get best results. Feed and feeding are not all; when fowls are not laying, it must not be thought that the ration is necessarily at fault unless there is good reason to believe so. Even though some other ration may be better, it is not advantageous to make a sudden change in its favor, because such changes are sure to upset egg production for greater or less time. Any changes found necessary should be made gradually. It is just as important also to feed at regular times and in regular amounts. "A feast and famine" will never produce best results. Every night the hen should go to roost with a full crop and should find her breakfast ready for her when she gets up. Success in poultry feeding, especially for eggs, depends upon wholesome food fed liberally, regularly and in variety, and upon plenty of activity for the fowls.

### VALUE OF SKIM MILK

At the West Virginia experiment station Professors Stewart and Atwood sought to determine the value of skim milk for laying hens. On most farms skim milk is fed to calves or pigs. Can fowls use it to better advantage? Separator skim milk was used. Generally during the colder months it was sour when fed, and during the warmer periods thick also. Two experiments were conducted, one for 122 days, the other for three months. In the first, two lots of Single Comb White Leghorn fowls were used, each lot containing 20 hens and 2 cocks. In the second each lot consisted of 60 hens and 6 cocks.

The skim milk was used to moisten the ground feed. This was usually fed in the morning, while

the whole grain was scattered in the afternoon in the litter covering the floors of the poultry houses. At no time were the fowls fed heavily, as the eggs which were laid were used for hatching and it was not considered desirable to become too fat.

### Weight of Fowls

	PEN 1		PEN 2	
	Hens	Cocks	Hens	Cocks
Average weight at the beginning of the test..				
Average weight at the end of the test.....	3.50 lbs.	4.25 lbs.	3.62 lbs.	4.50 lbs.
	2.77 lbs.	4.75 lbs.	2.90 lbs.	4.65 lbs.

The table shows that the hens in each lot lost in weight about seven-tenths of a pound each, while the cocks gained slightly.

The following table shows the amount and kind of food consumed by each lot of 22 fowls during the 122 days of the test. Both lots were fed exactly the same except that lot 1 received in addition 2 quarts of skim milk daily, or 244 quarts during the experiment:

### Food Consumed in 122 Days

Gluten feed ...	60 lbs	at \$1.275	100 lbs....	\$ .765
Wheat bran ..	60 "	at 1.20	" " ....	.72
Ground oats ..	60 "	at 1.40	" " ....	.84
Oil meal .....	20 "	at 1.40	" " ....	.28
Beef scrap ...	20 "	at 2.00	" " ....	.40
Corn .....	115 "	at 1.05	" " ....	1.20
Wheat .....	115 "	at 1.66	" " ....	1.91
Oats .....	115 "	at 1.25	" " ....	1.437
Total cost .....				\$7.752

If the skim milk be valued at 1 cent a quart, which is practically equivalent to 50 cents a hundred pounds, an extremely high valuation for feeding purposes, then the total cost of food for pen 1 was \$10.19 and for pen 2, \$7.75.

The following table shows the number of eggs laid by each lot:

	PEN 1	PEN 2
February 29—March 31.....	364	327
March 31—April 30.....	297	262
April 30—May 31.....	319	207
May 31—June 29.....	264	200
	1244	996
Total.....	1244	996

The pen which received the skim milk laid 248 eggs more than the other, or practically an extra egg for every quart of skim milk they received. Valuing the skim milk at 1 cent a quart, the food cost of 1 dozen eggs was 9.8 cents a dozen for the fowls fed the skim milk and 9.3 cents for the other lot. During the time covered by the experiment the eggs produced were actually worth 20 cents a dozen. The 248 extra eggs produced by pen 1 when valued at this price were worth \$4.13, which would give to the skim milk a value of 1.6 cents a quart.

In a second test 6 pens of Single Comb White Leghorn fowls were employed, each pen containing 20 hens and 2 cocks. The experiment was divided into two periods, June 30 to August 5, and August 6 to September 30. During the first period pens 1, 2 and 3 each received two quarts of skim milk daily to moisten the ground feed, as in the earlier experiment, while during the second period pens 4, 5 and 6 received the skim milk. It was found that



all the hens increased slightly in weight during the tests. The following table shows the amount, kind and cost of food consumed during the first period of 37 days:

#### Food Consumed by Pens 1, 2 and 3

Gluten feed	....54 lbs	at \$1.275	100 lbs....\$ .688
Wheat bran	...54 "	at 1.20	" " .... .643
Ground oats	...54 "	at 1.40	" " .... .756
Beef scrap	....18 "	at 2.00	" " .... .36
Corn	.....59 "	at 1.05	" " .... .619
Wheat	.....59 "	at 1.66	" " .... .979
Oats	.....59 "	at 1.25	" " .... .737
Total	<hr/> \$3.87		

#### Food Consumed by Pens 4, 5 and 6

Gluten feed	....60 lbs	at \$1.275	100 lbs....\$ .76
Wheat bran	...60 "	at 1.20	" " .... .72
Ground oats	...60 "	at 1.40	" " .... .84
Beef scrap	....18 "	at 2.00	" " .... .36
Corn	.....60 "	at 1.05	" " .... .63
Wheat	.....60 "	at 1.66	" " .... .99
Oats	.....60 "	at 1.25	" " .... .75
Total cost	<hr/> \$5.05		

Valuing the skim milk at 1 cent a quart, the cost of food for pens 1, 2 and 3 was \$6.09, and for pens 4, 5 and 6 \$5.05. The following table shows the number of eggs laid by each pen of fowls during the period:

Pens	.....	1	2	3	4	5	6
Eggs	.....	337	279	246	207	202	223
Totals	..	<hr/>			<hr/>		
		862			632		

The balance in favor of the milk-fed fowls was 230 eggs, which extra egg production was brought about by feeding 222 quarts of skim milk, or slightly more than an extra egg for every quart of skim milk fed. Valuing the skim milk at 1 cent a quart, the food cost of the eggs from the milk-fed fowls was 8.4 cents a dozen; and 8.3 cents for the other lot. The eggs produced during this period were worth in the local market 25 cents a dozen. At this price the 230 extra eggs were worth \$4.79, which would give to the 222 quarts of skim milk an actual feeding value of slightly more than 2 cents a quart when fed in small quantities as in this experiment.

During the second period of 56 days skim milk was fed to pens 4, 5 and 6, instead of pens 1, 2 and 3. During this period the hens which received the skim milk increased in weight slightly more than those whose mash was moistened with water. The following table shows the kind, amount and cost of the food consumed during this period:

#### Food Consumed by Pens 1, 2 and 3

Corn meal	.....105 lbs	at \$1.25	100 lbs	....\$1.31
Wheat bran	....105 "	at 1.20	" "	.... 1.26
Ground oats	...105 "	at 1.40	" "	.... 1.47
Beef scrap	.... 33 "	at 2.00	" "	.... .66
Corn	.....180 "	at 1.05	" "	.... 1.89
Oats	.....180 "	at 1.25	" "	.... 2.25
Total cost				.....\$8.84

### Food Consumed by Pens 4, 5 and 6

Corn meal	....101 lbs	at \$1.25	100 lbs	....\$1.262
Wheat bran	...101 "	at 1.20	" "	.... 1.212
Ground oats	..101 "	at 1.40	" "	.... 1.414
Beef scrap	.... 33 "	at 2.00	" "	.... .660
Corn	.....149	at 1.05	" "	.... 1.564
Oats	.....149	at 1.25	" "	.... 1.862

Total cost .....\$7.74

Valuing the 6 quarts of skim milk fed to pens 4, 5 and 6 at 1 cent a quart, the total cost of food for these pens was \$11.10 and for the other fowls \$8.84. The following table shows the number of eggs laid by each pen of fowls during the second period:

Pens	.....	1	2	3	4	5	6
Eggs	.....	302	363	313	452	382	386
Totals	..	978			1,220		

During this period there were fed 336 quarts of skim milk, which increased the egg production 242 eggs, or at the rate of three-fourths of an egg for every quart of skim milk fed. The eggs produced during this period were worth 25 cents a dozen in the local market. Valuing the 242 extra eggs at this price, it is seen that the skim milk had a feeding value in this case of 1½ cents a quart.

In both experiments more eggs were produced when skim milk was substituted for water for moistening the mash. Under the conditions prevailing in these experiments and with eggs selling for 20 or 25 cents a dozen the skim milk had a feeding value

of  $1\frac{1}{2}$  to 2 cents a quart. In these trials 802 quarts of skim milk were fed, resulting in an increase in the egg production of 702 eggs.

## FEEDING CAPONS

The unusually high prices quoted for capons has led to considerable discussion in the agricultural and poultry press relative to the profit in this branch of poultry raising. The discussion is not free from exaggerated statements of interested individuals, and little satisfactory information is available. To get data concerning the growth and food cost several feeding experiments have been made by the New York experiment station.

Six lots of capons and one of cockerels were fed for several months and several lots of capons for shorter periods of several weeks. Birds of several breeds and crosses were used, chiefly Asiatics, but none of the smaller breeds. No special comparison of breeds was attempted, although for the most part each lot was of one breed.

To all of these fowls sweet skim milk was fed nearly all of the time in place of water. Much of the time it constituted about 60% of the total food, supplying generally from 12 to 15% of the total dry matter in the ration.

For the eight lots for which records were kept the longest time, from hatching to maturity, the lowest pound cost, live weight, was at the average weight of 4 pounds. Largely because the market prices were always lower for the smaller fowls the cost of food to grow the birds  $4\frac{1}{2}$  pounds represented the highest proportion (a little over 50%) of the market value found at any time from earliest

marketable size as broilers to the heaviest capons. From the time the capons weighed 5 pounds until they weighed  $10\frac{1}{2}$  pounds the total cost of food consumed did not at any time reach half of the market value. Although the cost of every pound added to the weight was greater as the birds approached maturity than it had been for any earlier increase, the prices for the largest fowls were so much higher than for the smaller that the margin over cost of production was always greater with the nearly full-grown capons. On this account the later feeding was justified, so long as there was a regular increase in weight, until the spring months, at which time the greatest demand for capons and highest prices usually prevail.

One lot of capons was fed for comparison with a lot of cockerels taken from the same flock of chicks. For the whole period that record was kept, nearly six months, the cockerels increased in weight about 30% faster than the capons, but the rate of growth was much more irregular. At the average weight of 6 pounds the capons had cost for food 12% more than the cockerels; but more food was required on the average by the cockerels, so that at 9 pounds weight these had cost over 8% more than the capons. As the cockerels grew faster and larger than the capons, they averaged about  $10\frac{1}{4}$  pounds before the capons had reached the weight of  $9\frac{1}{2}$  pounds, and at the heaviest weights had cost no more for food.

At the average prices then existing in New York state markets the cockerels could have been sold at the greatest profit at about 6 pounds weight, and the capons not until they had reached the weight of 9 pounds, at which weight the difference be-

tween the cost of food and the market value was two and one-half times as great as for the cockerels. In some markets and more generally in recent years better relative prices have prevailed for such poultry as well-fed cockerels, so this difference found at the time in favor of capons would often be much smaller.

## CHAPTER VIII

### Egg Production

While it is true that a small yield of eggs is likely to be unprofitable, it does not necessarily follow that a large yield is invariably profitable. This may be because the cost of production is disproportionate to the amount realized, but since the aim of egg production is usually profit, it is highly desirable to increase the egg yield as much as possible within reasonable limits. It often happens that in striving to attain this end a poultry raiser who has made a good profit out of a small flock may lose by keeping a large one, because the egg yield may be increased only at unreasonable expense.

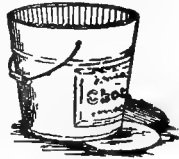

EGG PAIL  
Bottom and sides  
corrugated paper.

The great majority of farmers' flocks lay eggs only during what may be called the "natural season" of the year, mainly in the spring and early summer. One of the principal reasons for this is that the fowls are usually kept in an almost natural state. They do not receive the special attention that the egg farmer gives his flocks. Doubtless the great majority could be made to yield eggs well throughout the year by proper management—management such as the egg farmer gives his flocks. But where it would be profitable to the ordinary farmer to give the extra care essential to such egg production can only be determined by the farmer himself.

The cost of production on the general farm is

practically nothing in actual cash outlay, that is, where the flock is not large. The eggs in such cases are looked upon as just so much money lying loose and are gathered to keep it from being lost. In such cases, it is highly probable that fowls could be made to pay well by giving them a reasonable amount of attention, especially as the season thrives, when eggs sell at high prices.

### A HEN'S TOTAL YEARLY PRODUCTION

is not invariably the most desirable measure of egg-producing capacity. Actual production is less important than the season during which the eggs are laid. According to Raymond Pearl and Frank M.

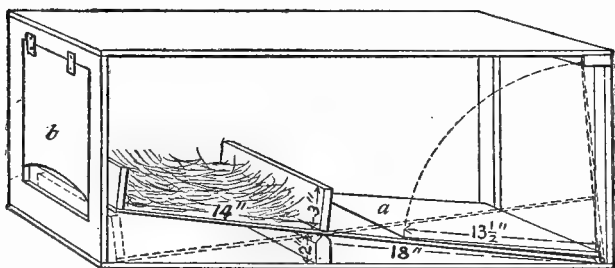

TRAP NEST BETWEEN PENS

After hen has laid she passes into empty pen through door, b. Layers thus separate themselves from general flock. Door, a, closes as hen enters and opens when she leaves by door b. Time saver for busy farmer.

Surface of the Maine experiment station "the measure of an individual hen's egg production in any given time may be taken to be the percentage which the number of eggs actually laid is of the maximum number of eggs which might have been laid by the individual in this given length of time, assuming the production of one egg a day to be the



maximum of which a hen is capable." A hen which lays 20 eggs during June would, therefore, have an egg-production record of  $66\frac{2}{3}$  per cent for June. If she lays 31 eggs during December and January, 62 days, she would have a 50 per cent record for those months. The above rule thus puts egg records on a comparative basis. This is of great advantage in calculating the value of the hen.

### SELECTING LAYERS

Laying hens are nearly always singers. They work and hunt for food all day, and are the first off of the roost and the last to go to roost. They are nervous and very active, keeping themselves up to the greatest possible pitch. Below the tail at the end of the side pieces of the back are two somewhat bony protuberances called the pelvic or "lay" bones. They are just above the vent through which the eggs must pass. When an egg is laid, they are forced apart to allow free passage. When these bones are soft and pliable, and spread sufficiently to allow three fingers to be placed between them, it is an indication that the hen is laying. If they are hard and bony and close together experience has shown the hen is not laying at the time the examination is made.

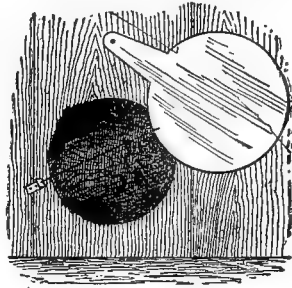

TRAP NEST DOOR

The ideal laying hen should, therefore, conform

as nearly as possible to the following: She must be healthy; comb, wattles and face red; eye bright and lustrous; neck not short, but medium to long; breast broad and long, sloping upward; back, long and broad; abdomen, wide and deeper than breast; shanks, well spread and rather long; V-shaped in three ways, viz., on sides (front to rear), top and bottom (front to rear), base of tail (downwards); well-spread tail.

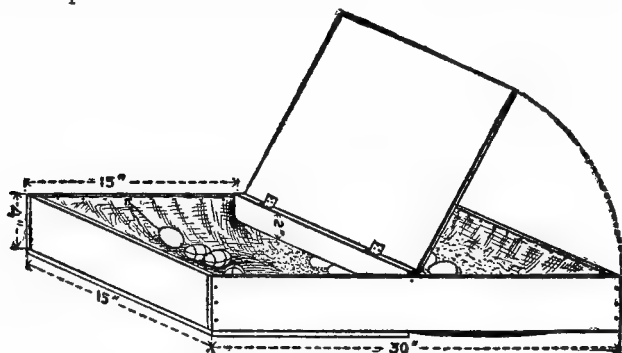

NEST TO CURE EGG EATING

Placed with slight tilt from left to right so egg will roll under covered part where sawdust or chaff checks rolling and protects from injury.

## LAYING ABILITY IMPROVED

Since egg production when eggs bring high prices is the leading desire of the poultryman, it is highly important that the hens be brought into laying as early as possible. The reason for this is that when hens begin to lay in the fall they are more likely to continue than if they are counted upon to start about the beginning of the new year—that is, under ordinary farm care. Many pullets

that begin to lay in the fall are naturally poor layers and soon play out. The sooner such fowls are taken out of the flock, the better. They should not be used for breeding. An important thing to remember in rearing fowls for winter laying is to have the pullets mature between September and November. This can be determined by the date of hatching and by the method of rearing. The Asiatic breeds require much longer than the Mediterranean classes.

The American fowls hatched between late March and early May will usually begin laying during October, provided they are properly managed, but too much confidence must not be placed in this statement, because hens differ so much individually and also because methods of management vary greatly. The only thing that can be said definitely on this point is that such calculation helps in the long run and it is better to have some system that embraces as many helpful features as possible, than to have no system at all. It must be remembered that the winter is not the season which is favorable to egg production. Therefore, the poultry raiser has to contend with unfavorable conditions, especially the condition of cold and wet, to say nothing of the natural tendency.

## MANAGEMENT OF LAYING STOCK

So far as egg laying is concerned, the egg farmer's year begins in October. Of course, circumstances may alter cases, but this is the usual time. Everything should then be put in readiness for egg production. The pullets and hens should be placed in their permanent winter quarters and special care

taken to prevent overcrowding. The sooner the flocks are made up, the better as a rule, because they then get accustomed to their quarters and there is less danger of upsetting them when they begin to lay.

None but mature pullets should be selected for laying. All that are puny, undersized, lazy, weak or otherwise undesirable, should be weeded out and sold for the table. They will not pay their board. Of course, this statement does not apply to late-hatched pullets; only those that are inferior to other stock hatched at the same time.

Only such hens as have proved their worthiness in the previous season should be kept over for a second or third winter. They usually make good breeders and the breeding flock should be selected from them rather than from pullets. Too often, however, in the farm flock, the reverse practice is followed, namely, of selling off the hens that are in best condition and using inferior ones for egg production. This is suicidal to profit. It should be reversed.

It is just as important to feed well for eggs as it is to breed well for them. As soon as cold weather approaches, corn must be added more freely to the ration than during the warm weather. Contrary to popular opinion, hens that are molting should be fed well. It does not pay to stint them. However, they should not get a ration too rich in nitrogenous matter, because they are not, as a rule, laying and they do better when given a ration richer than usual in carbonaceous ingredients. Even if this is a fattening ration, it will do no harm. By this, it is not meant that the nitrogenous matter should be cut out of the ration altogether. Feather produc-

tion demands protein which must not be fed too sparingly. It is superior, as a general rule, to have the fowls somewhat too fat than poor or even in merely good condition. By proper management, many good laying hens will lay an occasional egg even while going through the molting, but this is not general.

Pullets can be fed more highly than hens during the early fall months, because they already have their feathers and are still growing. At this time, they need abundant protein, because they are not only growing in flesh but are filling out their bones and either preparing for, or actually laying.

A pullet is by no means fully matured when she starts to lay. It needs ample food to complete its development. For best results, however, pullets, should not be unduly forced to begin laying early. Indeed, it is often disadvantageous to delay laying somewhat by frequently changing the pullets' quarters. This is the only method that can be practiced with safety. It will not do to withhold food. This statement has special application to the temperature, for as the weather grows colder, larger and larger quantities of feed, especially all the carbonaceous kinds, is used to maintain the heat of the body. For this reason corn should be given more liberally, and kale, cabbage, alfalfa, clover, etc., should be given without stint.

By proper management, egg production may continue without interruption during even extremely cold weather, but, in order to maintain the flow of eggs, the hens must be protected as indicated elsewhere, against sudden change. Properly housed fowls will usually lay well no matter what the character of weather, provided the poultryman is deft

in offsetting excessive fluctuations of temperature and moisture. Because large quantities of carbonaceous matter are used in maintaining the heat, a carbonaceous ration may be better for egg production during very cold weather than a nitrogenous one. This will be gathered from the discussion in the chapter on feeding, but it needs to be emphasized here. So much carbonaceous matter is used up to maintain the heat of the fowl that there should be still enough surplus of protein to meet the demands of egg laying.

### SPRING AND SUMMER CARE

This matter is of great importance, because, as a rule, the poultryman is likely to overlook the fact that hens lay more naturally in the spring than during the winter and, therefore, he may jump to the conclusion that his method of feeding is correct, whereas it may be positively detrimental to his best interests. For this reason, it is best that hens be allowed to become broody in early spring, so that they may have a rest of a few weeks. They will be all the better for hatching a brood of chicks and can be brought back into laying condition again even while they are running with their broods. Of course, this remark does not apply to the Mediterranean and other laying classes. Laying hens should invariably be given the utmost care to keep them in prime condition. This cannot be too strongly emphasized.

During the summer, hens usually take a rest from laying, but there will still be individuals in the flock that continue, and proper feeding will keep them in laying condition. Large numbers of eggs, however, must not be expected.

Plenty of shade should be provided during this time and the houses kept as open as possible so as to be cool and comfortable for roosting. Where it is not convenient to have the hens run in orchards or small fruit plantations, convenient shade may be provided by quick-growing annuals such as sunflowers, corn, vines of various kinds or artificial shelters made of canvas, illustrated on other pages. During the heat of the day they should be encouraged to occupy these quarters, and dur-

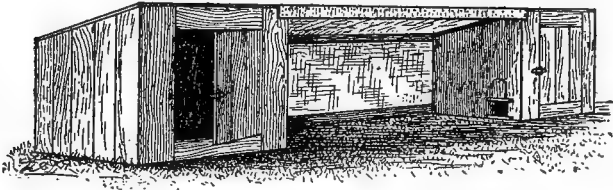

DOUBLE POULTRY HOUSE AND RUN

The run may have canvas top and back or wood, as preferred. It should be removable, so houses may be used in summer for colony coops if desired.

ing the mornings and evenings take other exercise. At these times the feeds of grain may be given, the mash feed at noon, except where hopper feeding is the method practiced. About midday also they should be given other green feed, unless they are at range.

As a general proposition, it may be said that fowls do best when given plenty of space to forage in. Since green feed is more or less cooling, it may be given twice a day in the hottest weather. At all times during the summer there should be abundant pure water always where the hens can reach it. Milk, as much as the hens will drink, is

always acceptable, especially during hot weather. It should not, however, take the place of water. During the hot weather, too, the corn part of the ration should be reduced even to total exclusion.

When hens cease laying unduly early in the summer, when managed in the usual way, these should be culled out and managed differently from

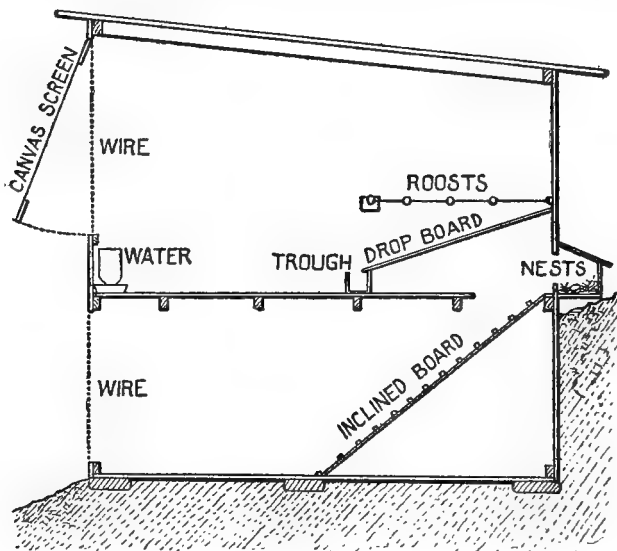

SIDE HILL POULTRY HOUSE

Lower floor, a scratching shed; upper, for laying, roosting, etc.

the balance of the flock. As a rule, a heavy laying ration, with reduced exercise, may start them laying again. Those that do not begin within a reasonable time should be marketed, and even the ones that lay for only a few weeks and then





BARRED PLYMOUTH ROCK HEN



LIGHT BRAHMA COCK

stop, should also be sold. Only the ones that show a willingness to continue laying should be kept. It may be taken as a general rule that it is not desirable to part with a hen so long as she will lay a profitable number of eggs. She will pay for her keep as long as she lays.

### **AUTUMN CARE OF LAYERS**

When making up the flock in the fall, the hens that began laying earliest and laid best with the least fussing should be chosen first. Next to this should come the hens that did best during the summer. It is a much disputed question whether pullets or hens do best as layers. Many poultrymen claim that pullets are superior and, therefore, the more profitable, but there is nothing decided on this subject. Many egg farmers get excellent egg yields from hens two to four years old—fully as good as from pullets. Because of this fact, it is evident there is much in the method of management and in the breeding. For this reason the statement may be repeated—not to part with a hen so long as she lays well. A hen on the nest is worth two pullets in the field.

### **GENTLENESS AFFECTS EGG YIELD**

Probably few things work so much against the well being of the fowls as excitement, due to rough handling or to fear from any cause. At no time should the fowls be unnecessarily excited. Often the entrance of a dog or a cat or visitors in the pens will disturb the fowls, so these should be kept out as much as possible. Fowls on free range are not so likely to be disturbed because they get

around and see the world more. At all times the attendant should avoid making sudden motions, calling loudly, or otherwise startling the fowls. He should always control his temper and try to govern even the most annoying fowls without force. It is desirable to enter the pens as quietly as possible and even to presage entrance by making some noise such as low whistling, so the hens will know that he is approaching. When it is necessary to carry some unfamiliar object among the flock, this should be done gradually. Even the wearing of a different style of suit than usual, especially if this is of some gaudy color, will disturb the fowls until they are accustomed to it.

Hens, especially laying hens, become attached to their quarters. They, therefore, should not be unnecessarily moved because this also affects the laying, whether from homesickness or what is purely speculative, but the fact is the egg yield often suffers. Where it is absolutely necessary to make a change, this should be done with the least possible disturbance, preferably by driving the fowls gently to the new quarters. When

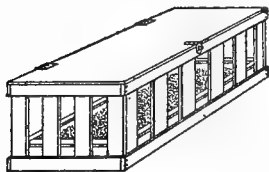

FEED COOP

Prevents fowls soiling feed.

number must be moved at a time, they must be placed in coops and so carried.

hens must be handled or carried, this should always be done at night and the fowls should be held gently with the hand beneath the breast; never by the feet. No more than two fowls should be carried at a time in this way—one under each arm. If a considerable number

must be moved at a time, they must be placed

## BROODINESS IS CHARACTERISTIC

of hens of the so-called general purpose breeds. It is not necessarily dependent upon the condition of the hens nor is it certainly dependent upon the method of feeding, though both of these may have some influence. It is a popular notion that fat hens become broody because of their fat. This is not necessarily so, though it is a fact that hens fed liberally on grain often do go broody, but so they do without just as often. It may be taken as axiomatic that hens will go broody when they want to, whether fat or lean. Occasionally it is reported that a hen dies on the nest and the poultryman asks why. Investigation generally shows that these hens were sick before they started to sit. Such hens should not be given an opportunity to sit. Their condition should be noted by the poultryman and they should be brought back to health by rational management.

Hens kept mainly for producing eggs often annoy the poultryman by persistent broodiness. They should, therefore, be culled out and never used for breeders. In otherwise normal hens, broodiness may be broken when necessary. It is, however, usually an advantage to allow the hens to hatch broods, since this gives them a rest from laying. Hens of the general purpose varieties usually lay better during the molt than hens of the noted egg breeds. These egg layers generally take a long rest, the sitters two or three short ones. In order to break up broodiness, one of the quickest ways is to confine the hens with a reserve male in a pen where there are no nests. While so confined, the hens should be fed well on an egg ration. This

method is more effective, as a rule, than the common way of confining hens in a slatted coop above the floor. Often the hens will begin to lay within a week or ten days. Under no condition should starving be practiced. It is not only cruel, but it is not effective and the poultryman who practices it pays the penalty by injuring the laying proclivities of the hen.

### RECORD OF SIX HUNDRED HENS

Among the questions for the poultryman to answer are: When fowls are kept in large numbers what is the average egg production? How much does it cost for feed? How much for labor to care for them? What per cent of the fowls die each year? How should fowls be fed and handled so as to give the greatest net profit, the cost of feed, the cost for feeding, the egg production and the mortality all being taken into consideration? These questions Professors Stewart and Atwood of the West Virginia experiment station have sought to answer by keeping a record of a flock of 600 Single Comb White Leghorn pullets for one full year. The pullets were brought in from the colony houses which they had occupied during the summer and placed in a long laying house.

This house was of the curtain-front, shed-roof type, 180 feet long and 16 feet wide and divided by solid board partitions into nine compartments each 20 feet long. The middle compartment was reserved as a feed room. The curtain-front house is distinguished by an opening, preferably facing the south or east, which, on cold nights in winter and in stormy weather, may be closed by a framework

covered with canvas or duck. This curtain is preferably hinged at the top and when not in use can be swung up to the roof and hooked out of the way.

A few months after the test began the dirt floors in the houses were covered with cement. The house was constructed of rough oak boards and

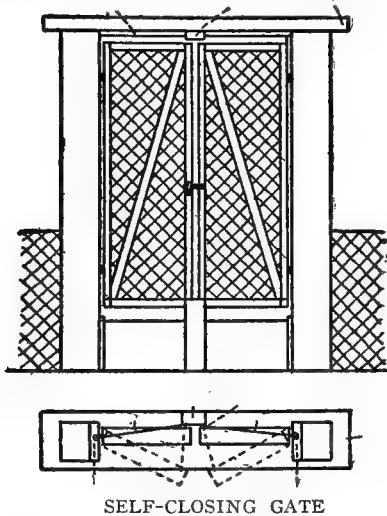

Either springs or weights may be used.

roofed with three-ply tarred roofing paper. The contract price for erecting was \$200, and the house complete cost about \$700.

The average weight of the pullets when the test began was 2.53 pounds, and the average age about five months, consequently many were not old enough to lay at the beginning of the experiment, and few eggs were obtained during the first two months. The floors were covered with straw litter

in which the whole grain, consisting of corn and wheat, was scattered. Ground feed was fed dry in hoppers which were constantly open to the fowls. The dry mash consisted of a mixture of cornmeal, wheat bran, wheat middlings, oil meal and beef scrap. On pleasant fall and winter days the fowls were allowed to run outside the house in one large flock where they had free range.

### Amount and Cost of Feed Consumed

	Pounds	Cost
Corn meal .....	3,441	\$42.88
Wheat bran .....	5,434	71.74
Wheat middlings .....	2,932	39.82
Oil meal .....	950	18.72
Wheat .....	10,509.6	152.21
Corn .....	8,952	103.81
Beef scrap .....	2,443	57.70
Green cut bone.....	178	1.33
Ensilage .....	1,536	3.75
Rye .....	1,120	16.80
Ground oats .....	337	5.73
Oyster shell .....	1,510	8.30
Mica crystal grit .....	1,400	7.70
	Gallons	
Skim milk .....	205	4.10
Total.....		\$534.59

The table shows that it cost \$534.59 to feed the flock for the year, or an average of 89 cents a head. The fowls consumed 36,296 pounds of grain, beef scrap and ground fresh meat and bone, or an average of 60 pounds a head; also an average of about 5 pounds of oyster shell and grit.

The highest egg production for any month was during March, when the fowls averaged 16 $\frac{2}{3}$  eggs a head. After that month there was a gradual dropping off until the close of the test. The following table shows the number of eggs produced during the year. The prices used in this calculation are retail prices which prevailed in Morgantown for strictly fresh eggs during period shown.



## Number and Value of Eggs Produced

Months	Monthly Total of Eggs Laid	Dozen Eggs	Price a Dozen	Value
November .....	1029	85 3-4	.35	\$ 30.01
December .....	3372	281	.40	112.40
January .....	4645	387 1-12	.35	135.48
February .....	5783	481 11-12	.30	144.58
March 1-10.....	} 9805 {	231 7-12	.30	69.47
March 10-15....		125 3-4	.22	27.66
March 15-31....		459 3-4	.20	91.95
April .....	8855	737 11-12	.20	147.58
May .....	8671	722 7-12	.20	144.51
June 1-14 .....	} 7405 {	295 11-12	.20	59.19
June 14-30 .....		321 1-6	.25	80.29
July .....	6632	552 2-3	.25	138.16
August 1-26....	} 6095 {	435 6-12	.25	108.86
August 26-31....		72 1-2	.28	20.30
September 1-23..	} 3916 {	264	.30	79.20
September 23-30..		62 1-3	.32	19.94
October 1-7.....	} 1542 {	46 5-6	.35	16.39
October 7-31....		82 1-4	.40	32.90
Total .....	67,757			\$1,458.87

The fowls produced eggs to the total value of \$1,458.87, or an average of \$2.43 a fowl. The period of lowest prices prevailed from March to June, and the highest priced during October, November and December.

If from the total value of the eggs the cost for feed is deducted, there remains a balance of \$924.28 to cover the cost for caring for the fowls, the death losses, the depreciation in value of the fowls, the interest on investment and profit. It is difficult to estimate accurately the cost for labor, as the man who cared for these fowls did other work. An active man could undoubtedly attend to five or six times as many fowls as were in this experiment. If, for calculation, the lower number be chosen, also if it costs \$50 a month for a man to do the work, then it would cost \$10 a month for each house, or \$720 a year. The loss of the 54 hens that died, at

\$8 a dozen, would amount to \$36. If it is assumed that the 600 pullets are worth \$400 at the beginning of the test and that they depreciate in value during the year 25 per cent, then this depreciation amounts to \$100. Assuming that the house and fowls represent an investment of \$1,100, then the interest at 6 per cent amounts to \$66 and the account stands as follows:

### Income

For eggs .....	\$1,458.87
	\$1,458.87

### Expenditures

For feed .....	\$534.59
For labor .....	120.00
For fowls which died.....	36.00
For depreciation in the value of fowls due to age...	100.00
For interest on investment.....	66.00
For profit on 600 hens.....	602.28
	\$1,458.87

The total profit from the 600 fowls was \$602.28, or practically \$1 a fowl. The total expense for the year was \$856.58, or \$1.42 a fowl. There were produced 5,646 dozen eggs at an average cost of 15 cents a dozen, and during the year 9 per cent of the fowls died. The fowls averaged 113 eggs each. It is possible that this somewhat low egg production could have been increased by some other system of feeding.

## CHAPTER IX

### **Incubation**

To the casual observer, an egg consists roughly of three parts, but to the scientific investigator these are capable of several subdivisions. The shell, composed of lime, forms a protection; but it is not an impenetrable cover. It is very porous. It has between the particles of lime an innumerable number of very small holes, which allow the air to pass freely backward and forward during the process of incubation. Next is the white, the albumen. This is not all of one character; one portion is much denser than the other. The watery portion is placed around the outer surface next to the shell.

In the interior is the yolk, which in itself is, as a whole, lighter in density than the white, therefore its tendency is to come to rest upon the surface of the white. But the yolk is also differently constituted, one portion being a little heavier than another, with the consequence that the heavier portion moves downward and the lighter up. There is a good deal of misunderstanding about the very dense jellylike portions of white. Popular conception says the young chick is developed from them, but this is wrong. They simply consist of denser and more gelatinous albumen, and have acquired that twisted, corkscrew appearance and shape by the revolutions of the yolk in traveling down the ovary of the hen. But this twisting assists in keep-

ing the light side up. It also prevents the yolk from being ruptured by sudden jar.

### INTERIOR STRUCTURE OF AN EGG

Open a new-laid egg without breaking the yolk. Resting on its side, carefully remove part of the shell, and you will find a little white speck about one-eighth inch in diameter on the yolk next to the shell. This is the true germinal spot, known as the blastoderm, the minute nucleus of what is afterward to be the chick. The term blastoderm in itself is a very suggestive one; it means the sprouting skin. The blastoderm is present whether the egg is fertile or not, so that for all practical purposes, it is quite impossible to tell beforehand whether an egg will produce a chick. An infertile and a fertile egg to the naked eye present the same appearance. The difference is so minute that unless one uses a microscope it would be quite hopeless to place any faith upon conclusions.

Not only is it impossible to foretell fertility, but it is impossible to foretell the sex of the chick which any given egg will produce. During the first few days an egg is developing, the reproductive organs in the chick it contains are in duplicate, and until the process of incubation is pretty well advanced, both sets of organs are present. Then one set grows more prominent than the other. The rapidity with which the change is made will amaze any thoughtful person. The application of a few hours' warmth of the required temperature brings into activity all the power lying dormant from the time the egg was laid. After five or six hours, little finger-like processes begin to creep out from

the blastoderm and gradually distribute themselves over the whole of the yolk.

At the end of 18 hours' incubation the head of the future chick, with the eyes enormously developed, and the spinal column, are plainly discernible under the microscope. After 40 hours there is a complete blood circulation, the heart is formed and beating has commenced, and the blood vessels have spread

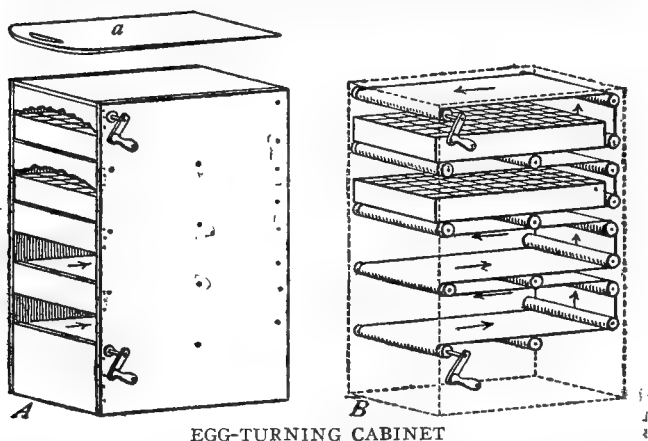

EGG-TURNING CABINET

Series of rollers over which canvas is stretched. Each compartment tray removable with false bottom, a, which slips between canvas and tray frame. A, shows cabinet complete; B, detail construction.

themselves over a considerable portion of the upper yolk. These are of a dual character; some are arteries, taking blood away from the embryo, some are veins bringing the blood back again. The heart commences pulsating about the second or third day.

When the blood circulation commences, the necessity for another organ which has been developing next to the shell arises. There is another

growth of vessels which follows the same course as the blood vessels. The natural reviver of impure blood is the oxygen in the air. There are no lungs in the shell, but this new organ, called the allantois, which lies next the shell, undertakes the work of breathing. Hence the necessity for the pores in the shell. If the shell were made non-porous the allantois would be useless. This has been proved with eggs which have had their pores filled with wax. When warmth is applied in the ordinary way, the first indication of growth appears, but the germ dies simply from want of fresh air.

### WHY EXERCISE CARE IN HANDLING

Some people test their eggs, particularly white-shelled ones, on the fourth day, though a much better course is to test them on the seventh or eighth day. Perhaps a caution is needed against testing eggs too frequently. It is very hard for a beginner to refrain from handling his eggs, but knowing the delicacy of the blood vessels, which form a perfect maze of tracery over the yolks, and knowing that these and a further set busy absorbing the yolk are very highly sensitive, he will perceive that the less he interferes with the eggs the less likely he is to damage this fragile and delicate interior.

Another reason for not testing frequently is that in so doing the eggs are held up to the light in an unnatural position and some of these organs inside the egg are being twisted. Again, there is the light. To test eggs properly a very clear light is needed to pass through the egg. Therefore eggs should be tested only once, and that about the seventh or

eighth day. If very doubtful about them, perhaps a second test might be given on the fourteenth day, not later, because between the tenth and eighteenth days is the most critical period in the life of the embryo.

In selecting eggs for hatching use only those that are of uniform size and color, with smooth, strong shells. Abnormal eggs are likely to produce weak or crippled chicks. The eggs should be stored in a room where the temperature ranges from 50 to 60 degrees. It has been a prevailing idea that eggs for hatching should be turned daily. Several men of authority claim that this is not necessary, but the case is not definitely proved. Eggs kept for a week or more should be turned at least twice a week. It can do no harm and may prove beneficial. Never set dirty eggs; if they are dirty, carefully wipe them with a damp cloth until all spots are removed.

### SHIPPING EGGS FOR HATCHING

The three most important points to be considered in packing and shipping eggs for hatching are: First, the boxes and filling should be as light as possible consistent with strength and rough handling; second, the handles of boxes must be so constructed that freight cannot be piled on top and thus crush them; third, the eggs must be prevented from jarring, and yet must not be packed so tightly as to cause breakage from pressure.

Light wooden boxes have proved most satisfactory with many poultrymen. They should be of enough depth to insure an inch of excelsior below the lowest layer. When used they are packed

about as follows: A layer of corrugated pasteboard cylinders rests on a piece of pasteboard next to the excelsior. Each of these cylinders contains an egg, small end down. The corrugations of the pasteboard come on the inside of the cylinder, and thus take up any jar. Over this is placed a second pasteboard, then a layer of excelsior, and at the top a board lid, which is screwed down with little screws. If more than one layer of eggs is to go in a box, a pasteboard is placed between the two layers of the cylinders.

The handle of the box must remain upright. A split-wood, rounded handle clearing the top of the box about 2 inches and fastened securely on both sides so it cannot move backward or forward, is excellent. It is best to have the handle fastened to the sides of the box and not to the lid, because there might be a strain on the latter, and the screws might give way, especially if 100 eggs are being shipped at a time. Some men stamp each egg with their initials and seal the lid to the box with a printed label pasted on. Then the customer can tell if the eggs have been changed in transit. The label gives the name and address of the poultryman and the name of the breeds of poultry raised printed on it. The name and address of the consignee are written on the blank. Last, but most important, a stamp or a label should always be applied on the lid, saying, "Eggs for Hatching, Handle With Care."

Many people object to the box for shipping eggs. The principal objection is that expressmen are more likely to throw boxes than they are the baskets. For this reason ordinary splint baskets with handles are very popular. In packing them a layer of ex-



celsior is placed on the bottom and around the sides. In this the eggs are carefully wrapped in excelsior or paper and the basket filled with excelsior and gently pressed down to prevent any possible shifting of the eggs from their positions. Cheesecloth or cotton is now tacked over the top and the words "eggs for hatching" painted or stenciled on the cloth itself. The label is fixed to the handle. Baskets, it is claimed, can be shipped with more certainty of their safe arrival than boxes. Upon receipt of a package or a basket of eggs for hatching, the eggs should not be removed unless the hen or the incubator is ready to receive them. Until hatching can be started the basket or the package should be turned over daily.

## CLASSES OF INCUBATORS

There are two very distinct types of incubators on the market; the hot-water tank and the hot-air machine. Perhaps the latter is really far more ancient than the former, but until a few years back there were no hot-air machines that could approach the hot-water tank. After giving both systems a very long and exhaustive trial, generally speaking results have proved satisfactory from both. There are certainly indifferent and bad examples in each kind to be obtained, and experiences vary accordingly. A great deal, then, depends upon the incubator purchased. It may be taken as a general rule that any machine which has a reputation of some years' standing has been found to answer very well in the hands of reasonable people.

The best incubator, of course, is the one which approaches in its work the closest to Nature. In

studying natural incubation there is, in the first place, top heat. Heat rising from below would never do, as it would evaporate the moisture from the eggs too quickly. The next point is steady warmth; when a hen is brooding, her temperature is invariable. The temperature of a brooding hen is about 104 degrees, and that does not vary a great deal during the time she is sitting. Therefore, in order to have a successful incubator, a machine capable of developing a top heat of 104 degrees to the eggs and keeping it steady there, is needed. Of course, the eggs under the hen will vary in temperature according to the position they take; that is to say, those under the breast will be rather warmer than those on the outside. But they are changed in position now and again. Each machine must possess a sufficiency of ventilation; fresh air is a perpetual necessity.

### MOISTURE ESSENTIAL

Another very greatly discussed question is that of moisture. Hot-air incubators are usually non-moisture machines, whereas the tank machines require added moisture. Perhaps there has been no bigger bone of contention between the manufacturers than this question of moisture or non-moisture. Within reasonable limits, both systems are satisfactory. A great many people overdo the moisture. Some manufacturers even advise that if chicks do not come out freely to dip the eggs in water. That is a ridiculous practice. Eggs do not require a lot of added moisture. The amount that should be passed through the machine should be just about sufficient to keep a check upon the

amount of evaporation. An egg contains about 85 per cent water, the body of a chick about 80 per cent, therefore a slight driving out is wanted and not an atmosphere always saturated.

## METHODS OF MANAGEMENT

Every reputable maker sends out instructions with his machine, and the purchaser should follow these implicitly. If he does not, he is running a risk for his own pocket, and he is not doing justice to the maker of the machine. He must also bear in mind that the instructions sent out with any machine are the result of experience with that particular make, and as the manufacturer's interest lies in obtaining satisfactory hatching, so the directions are to that end, and should be valued.

The incubator should be placed in a sunless room or cellar, or any place where the temperature is equable day and night, or fairly so. It is not an indication of good working in a machine if one running gets perhaps 80 per cent and on the next occasion only 50 per cent. There is something wrong somewhere. It has been rather the rage with advertisers to make a great fuss about 100 per cent results. Novices thinking about taking up the incubator must not be misled; 100 per cent results are exceedingly rare. If one gets 80 per cent on a six months' working, he may conclude that he made a very profitable deal in his machine.

One may have as good a machine as it is possible to get, but unless the eggs are right he cannot hatch them. Eggs must not only be fresh, but they must contain all the elements and the germs that go toward making good, strong chicks. Unless they

are carefully selected from stock birds kept in such a manner as to insure a certain amount of animal vitality, they cannot turn out strong, lusty chicks.

INCUBATOR RECORD												
NAME OF INCUBATOR .....		CAPACITY .....		NUMBER SET	NUMBER FERTILE 1ST TEST	PERCENTAGE FERTILE	NO. LIVING GERMS 2D TEST	PERCENTAGE LIVING GERMS	NUMBER OF CHICKS	PERCENTAGE FERTILE EGGS SET	PERCENTAGE OF LIVING GERMS	NO. CHICKS ALIVE AT 2 WEEKS OLD
NUMBER OF INCUBATOR .....		HATCH NO. ....										
DATE SET .....				DATE HATCHED .....								
EGGS FROM PEN NO. ....				BREED .....								
TOTALS												
DAY	TEMPERATURE OF ROOM A.M. P.M.		VENTILATION		TEMPERATURE OF INCUBATOR A.M. TO P.M.		REMARKS					
	1	65	60									
2	55	53	■									
3	49	47	■	■								
4	FIRST SOULING	45	44	■	■							
5		48	51	■	■							
6		54	57	■								
7		60	62									
8												
9	TEST											
10										AVERAGE TEMPERATURE OF INCUBATOR TO DATE		
11												
12												
13	TEST											
14												
15												
16												
17	LAST SOULING											
18	CLOSE									AVERAGE TEMPERATURE 11TH TO 18TH DAY		
19												
20												
21												
AVERAGES										RELATIVE HUMIDITY		
WAS MOISTURE USED ? .....												
WHEN ? .....												
HOW ? .....												
DESCRIPTION OF INCUBATOR ROOM .....												
.....												
.....												

RECORD CARD FOR INCUBATOR

This form shows a very convenient method of taking notes of hatches. Data secured in this way are often invaluable because they may lead to the detection of faulty management at weak points in the hatching methods practiced.

'Always get eggs from the best sources. Enough directions are not given about changing the position of the eggs in the drawer. Manufacturers say that the heat is the same all over the drawer, but not one machine in 1,000 will give the same heat in every part. Therefore, it is advisable to shift the eggs from place to place in the drawer.

### INCUBATOR MANAGEMENT

One of the most important factors in successful incubation is an abundant supply of oxygen, which the developing embryos must obtain only from sweet, fresh air. To get an abundance of fresh air where the incubator cellar is partly below ground is much more difficult than when the hatching room is level with the earth.

During the past few years there has been a considerable amount of controversy with regard to the operation of incubators with or without moisture. Poultrymen are generally agreed that moisture in some form is necessary. Two experiment stations have published bulletins showing that the machines which had moisture supplied gave larger hatches, and stronger chicks than the machines operated without being supplied with more moisture than is contained in the atmosphere. The publication of this work has led some large incubator manufacturers to equip their machines with automatic moisture regulators, and there is no doubt that this is a great improvement on the non-moisture machines. The conditions under which a machine is operated has everything to do with the success of the hatch. By his expert operation the experienced man may secure a good hatch from an in-

ferior incubator; on the other hand, an inexperienced man may, through lack of knowledge make a complete failure with even one of the best machines.

If the machine has just been purchased, it should be removed from the crate and assembled, care being exercised to follow the manufacturers' directions for putting the various parts together. In choosing a room, select one that will allow for ample ventilation without a direct draft on the machine. Do not place the machine in front of a window, as the direct rays of the sun will make it difficult to control the temperature. A cellar that can be ventilated and that is not too damp makes an excellent place for the machine.

For best results see that the machine is perfectly level; otherwise it will not distribute the heat evenly to all parts of the egg chamber. The lamp should be cleaned and filled with a good grade of kerosene, which will insure a steady flame and no smoke. The lamp should be lighted and placed in position, as it will require several hours to dry and warm the woodwork thoroughly. When the mercury in the thermometer registers 100 degrees, it will be necessary to read the thermometer every 15 or 20 minutes in order to adjust the thumbscrew on the regulator. When the thermometer registers 102 degrees adjust the thumbscrew so the tin disk on the regulator arm will be just trembling on the rise. The machine should be run for at least 24 hours before putting the eggs in. This will give an opportunity to study the regulator and see that the temperature remains steady.

The eggs are now placed in the machine and one must not be alarmed if the mercury in the ther-

thermometer recedes from sight. This is easily accounted for by the fact that the eggs are cold, and it will require several hours before the thermometer will again register 102 degrees. The eggs should not be disturbed until the third day. The only work required is cleaning and filling the lamp each evening. On the evening of the third day the eggs should be turned and cooled for five minutes. Be sure there is no grease on the hands when turning the eggs. After the third day turn and cool the eggs morning and evening, gradually increasing the amount of cooling as the hatch progresses.

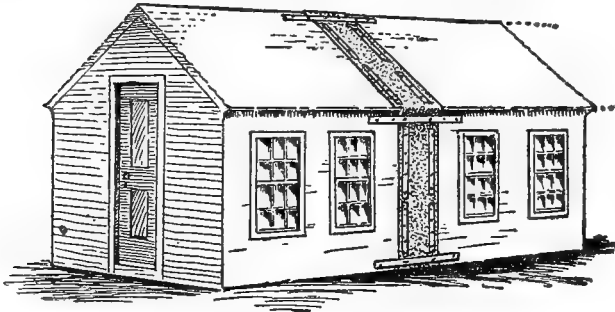

COLONY HOUSES COMBINED

In winter colony houses brought end to end thus may serve for general coop. Building paper tacked over ends.

### TESTING THE EGGS

The eggs should be tested on the seventh and fifteenth days. This may be done during the day if a dark room is available; if not, at night. The testing of the eggs is very easy and after a little practice one should experience no difficulty in distinguishing the good from the bad. When held to the light, a fertile egg can be distinguished by a

small, dark center (the heart) from which blood vessels radiate in every direction. The infertile or sterile eggs will be perfectly clear when held up to the light. Eggs that contain dead germs can be distinguished by a small, dark center, though sometimes this is lacking, surrounded by an irregular circle and the absence of blood vessels.

When the eggs are tested on the fifteenth day those that contain live chicks will appear, when held to the light, to be filled with a dark mass, which in reality is the developing embryo. The infertile eggs should be saved and used in feeding the young chicks for the first few days; they may also be used for baking purposes, as a slight evaporation is the only change that has resulted from incubation. The eggs should not be turned or cooled after the eighteenth day. Close the machine and do not disturb it, except to fill and trim the lamp, until the hatch is complete. While the eggs are hatching, the temperature of the machine may go as high as 105 or even 107 degrees; this is caused by the animal heat given off by the chicks and no attempt should be made to lower the temperature if the machine has been running properly just previous to hatching.

Before resetting, the machine should be cleaned and disinfected thoroughly, a new wick put in the lamp, and operated for a day or more in order to adjust the regulator properly.

## CARE OF THE INCUBATOR

Many incubators are short-lived. The owners complain of unsatisfactory results after the first season or two, but the trouble is more often due to



improper care of the machine during the idle season than to defectiveness. More of the life of an incubator depends upon care when not in use than upon any other one thing. The main thing to guard against is dampness, but exposure to weather conditions of any kind is always harmful. The aim, therefore, should be not merely to keep the machine dry, but where it will be as little influenced by outside conditions as possible.

A cellar, no matter how dry, is not a desirable place to store an incubator between seasons. An attic, a loft, or an upstairs airy room not in use are far better. Prior to being stored, the tank if a hot-water machine is used, should be drained while the water is still hot. Both the cap and the faucet should then be left open and the lamp burning with a very low flame until the tank has become thoroughly

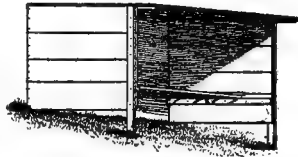

SIDE HILL COOP

Legs in front make roosts come level when coop is set on hillside.

dry, because of the circulation of air through the faucet and cap. The flame, if allowed to burn for an hour or two, should dry the machine well. The egg chamber should previously be thoroughly cleansed, scrubbed if necessary. No wood parts should be wetted, because where the wood is unprotected with varnish it will swell and shrink more or less. If the inside must be scrubbed, this should be done while the machine is still warm and the doors left open until everything is dry.

All removable parts should be taken off the outside and stored in the egg chamber. The lamp

should be emptied, the wick removed, and everything thoroughly washed. The burner should be cleaned and stored separately from the lamp, the chimney wrapped in cotton to insure against breakage, the thermometer packed in a little box of cotton, the egg tester, wrench, screw driver and other accessories also stored in the egg chamber. With everything possible removed from the outside, the machine may be stored in small space without danger of parts being broken; in fact, several machines may stand one upon another. As a further protection, they should be covered with cloths and kept so until needed the following spring.

Several weeks prior to starting the new hatch, the parts should be assembled, the machine set up and run to see that everything is in good order, so that any necessary new parts can be secured before the hatching season actually arrives. By such care, however, there should be no losses of parts, and the only thing that one should need would be wicks, an occasional new burner, and extra lamp chimneys to take the place of those that break through any accident.

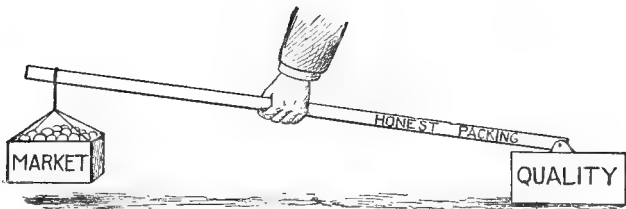

## CHAPTER X

### Rearing

Doubtless the most difficult poultry problem today is raising the chicks. To many it is more difficult than hatching. Not all these difficulties can be solved by attention to constitutional vigor in the selection of the breeding stock. Probably the great losses incident to the season of brooding can be largely overcome by paying proper attention to the stock that is to produce the chicks. Poultrymen who follow this practice experience very little loss of brooder chicks.

But vigorous stock and good incubation will not atone for gross sins in brooding and feeding. A good brooder permits the chicks to find a comfortable temperature at all times. This means that at some point a surplus of heat must be carried, a higher temperature than the chick can endure for a very long time. The chick moves away from this heat and finds a comfortable place where it will lie down alone and sleep. When chicks crowd together they are not getting sufficient heat. Crowding or piling up is always disastrous. The chicks sweat—if a chick can sweat—and then chill, and lowered vitality and death follow. Chicks never crowd in a brooder where the heat is sufficient. If at night they are seen to crowd together and are standing up the brooder heat is not right. They should lie down singly and sleep contentedly. The brooder should be heated by hot air currents, thus providing both heat and ventilation at once.

There must be ample room for the chicks to escape from too high a temperature, and the brooder must admit of being easily and rapidly cleaned. A brooder that does not embody these features is not worth consideration, and will be sure to foster loss. The heaters should be started several days before the chicks are to be put in so the brooders may be thoroughly warm and dry by the time the chicks are ready to be put in. An inch of dry, clean sand

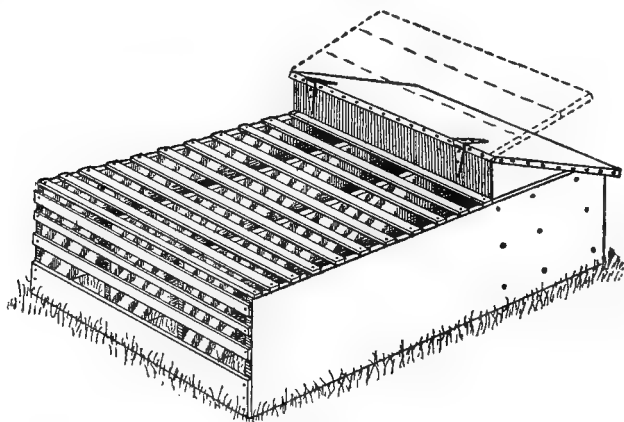

#### NESTS AND RUNS FOR BROODY HENS

Runs and nests 15 inches wide and high and 4 feet long. Lath over runs. Roof hinged to reach nests.

on the floors well warmed and dried is ideal. The temperature should be under the hover around 100 degrees. Oil lamps as the source of heat demand much attention to keep them going properly. The incubator lamp is a very safe device, the brooder lamp is not so safe; in fact, most of the brooders on the market are to be considered rather danger-

ous, and it is well to be a bit cautious with regard to fire. The flame should be turned very low in starting the lamp till the brooder is well heated, then it may be adjusted to suit. If adjusted before the lamp parts are heated, it is sure to run up so high as to be dangerous with the heating of the lamp.

### MANAGING THE BROODER

The success of brooding chicks artificially is having the brooding conditions the first few days similar to incubating conditions; not that the brooder is constructed like the incubator, but it has to be good enough to hatch eggs in, because in the four days that succeed the exclusion from the shell incubation is not really completed until the yolk is absorbed. The little chick that comes from the shell is very much like an infant; it has a tendency to lie around and sleep, and the nearer incubator conditions are reached in the brooder at the start the better it will be. The temperature would run from 85 to 90 degrees during this period, on a line with the chicks. Heat, if not too much, is beneficial.

When the chicks are put under a self-regulating hover, the heating conditions right themselves and one should not need to worry any more about the chicks than if they were eggs in an incubator; while if one has to depend on turning the lamp up and down to control the heat in operating brooders, especially out of doors, where there are extreme temperature variations to contend with, from 30 to 60 degrees in a day, that means that the operator has to be on hand a good part of the time.

During the first week of a chick's life heat is more important than food. Attempting to furnish this heat by excessive feeding to maintain the body temperature from within, we are pretty sure to overload the digestive system, and it seems to be the part of economy to supply the heat by oil or coal rather than by foods given the chicks.

### COMPARE NATURAL METHODS

If one would have greatest success in the rearing of chicks he must study Nature and the methods



**CHICK BLOCK**

Chicks peck soft food piled around handle.

Nature uses, and apply the lesson thus learned to the work at hand. Watch an old hen steal her nest in some fence corner, bring off a brood and care for it without aid. Barring accident these chicks live and grow well. Study closely how and what they are fed. Chicks should be left in the incubator for 40 hours after the hatch is out. Then they may be put in the brooder and given a little warm water, that they may learn to drink. When three days old they are ready for their first feed. They may have already picked a little sand from the floor of the brooder.

More chicks are lost from feeding too soon than from most other causes. Nature put into the egg enough of just the right kind of food to keep the chick going till strong enough to get its sustenance without. When we feed too soon we interfere with Nature's plan and pay the penalty in losses later

on. At the Kansas experiment station the best results were had by letting the chicks go without food for 90 hours after hatching. If the reader is skeptical on this point try it a time or two in a small way. We get back to Nature and make the first feed for the chicks by cutting into fine bits some tender grass. The amount needed is small. The hen that stole her nest and brought off a brood did not provide much for the chicks for the first few days. Many persons make the great mistake of overfeeding while the chicks are young. They usually pay the price in dead chicks later on.

At first it is best not to use bedding materials that are indigestible or that may be eaten. Little chicks are very foolish birds. When taken from the incubator and placed in the brooder, they attempt to eat anything they can swallow. Too often they succeed and many a flock has been killed by filling up on bran, sawdust or sand. The first choice would be cut clover, next cut straw, barn litter or chaff, sweet and free from mold and decayed particles. After the first week almost anything can be used. One of the best materials available is dry earth, especially in warm weather. It absorbs the droppings and is a good disinfectant. Bedding should always cover the brooder floor at least 1 inch thick, and be short enough to let the chicks scratch in it. Dry chick feeds should always be fed in the litter, and every inducement given the chicks to exercise.

One thing to bear in mind in feeding young chicks is that the ability to select nourishing foods from injurious or harmful substances does not develop so quickly in the brooder chick as in the chick that associates with the hen. This instinct

does not develop until the brooder chick is eight or ten days old. The time, of course, varies with strain and breed. The same chick under a hen will be able to distinguish feed in two or three days. From the hen the little chick seems to acquire this ability to know injurious or noxious substances. When the chick is placed direct from the incubator in the brooder it does not seem to have this ability,

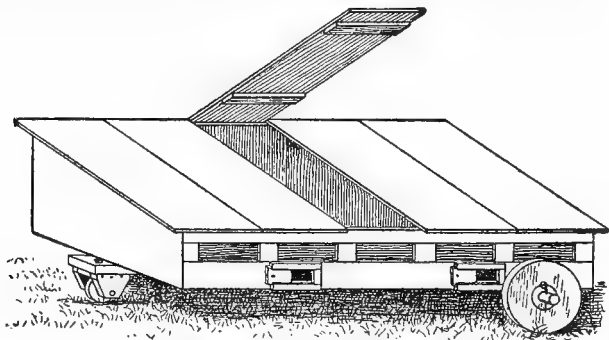

BROODER ON WHEELS

Front wheel pivoted for easy turning. Top hinged at back, loose in front. Runs placed at openings on side.

and shows a tendency to eat anything that it can swallow. Knowledge of this makes the matter of feeding little chicks very simple. Green food should not be neglected in the little chick's diet; it must be provided in some shape or form, even if the chicks are upon a grass range. After May or June the grass becomes too tough for them to eat and green feed must be supplied in some manner.

### HOW OFTEN TO FEED

At first it is well to feed five times daily; later three times, and lastly by hopper altogether. Never



give hopper feeding till chicks are at least six weeks old, and when they are put out on range. The first two weeks is the critical period. If one has no milk for them, beef scraps, curds or cottage cheese may be used. The colony system and individual brooder out of doors is the best process of raising chicks. If one cannot raise chicks in this way there is no hope for him.

After a few feeds of cut grass give small amounts of the prepared nursery chick feeds to take the place of the seeds Nature supplies. A little later let the chicks have access to a shallow tray containing a mixture of high-grade dried beef scrap and bran, using 100 pounds of beef scrap, 50 pounds of coarse wheat bran and 15 pounds granulated charcoal. It will take the chicks some days to become accustomed to eating this mixture, and by the time they learn it, it is safe to keep it before them at all times. The grain and seeds composing the chick feeds may be thrown into finely cut corn stover, hay or other loose material after the chicks are four or five days old, so they may get the fun and exercise of scratching

it out. There is not much danger of overfeeding after the chicks are 12 days old. From that time on it should be the object to have them eat the largest possible amount of proper feed. They grow rapidly

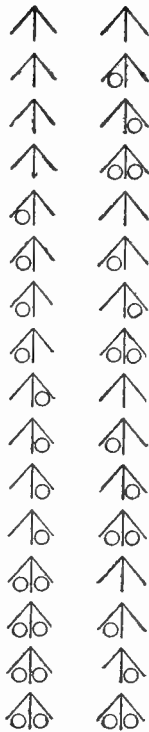

CHICK  
MARKING

Holes punched between toes of newly hatched chicks.

and need to be well nourished. The foodstuffs must be highly digestible and should furnish as nearly as possible every element needed by the system of the chick. Large amounts of the carbonaceous,

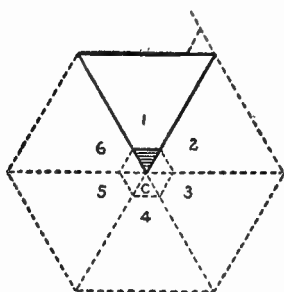

TRIANGULAR COOP  
AND YARD

Moved daily as shown by  
dotted lines.

or energy-giving material are needed, because the chick is a lively, energetic fellow; also an abundance of protein, the blood-building, muscle and feather-making material, and enough of mineral matter to build bone and help the protein build the feathers. This is best secured in freshly cracked corn, a mixture of beef scrap and bran, an abundance of green cut grass, sand oyster shells, charcoal and crushed raw potatoes.

## REARING CHICKS WITH HENS

A good beginning in rearing chicks with hens is to have a proper kind of coop, one with a removable floor bottom that can be easily cleaned and one that can be easily and securely closed at night to guard against the various kinds of night prowlers which may come around. The coop should be tight, so as to remain perfectly dry inside in wet weather. It should have a closed front, excepting an opening about 1 foot square in which is fitted a sliding wire screen door and also a tight floor if for early chicks.

The coops should be placed on new ground,

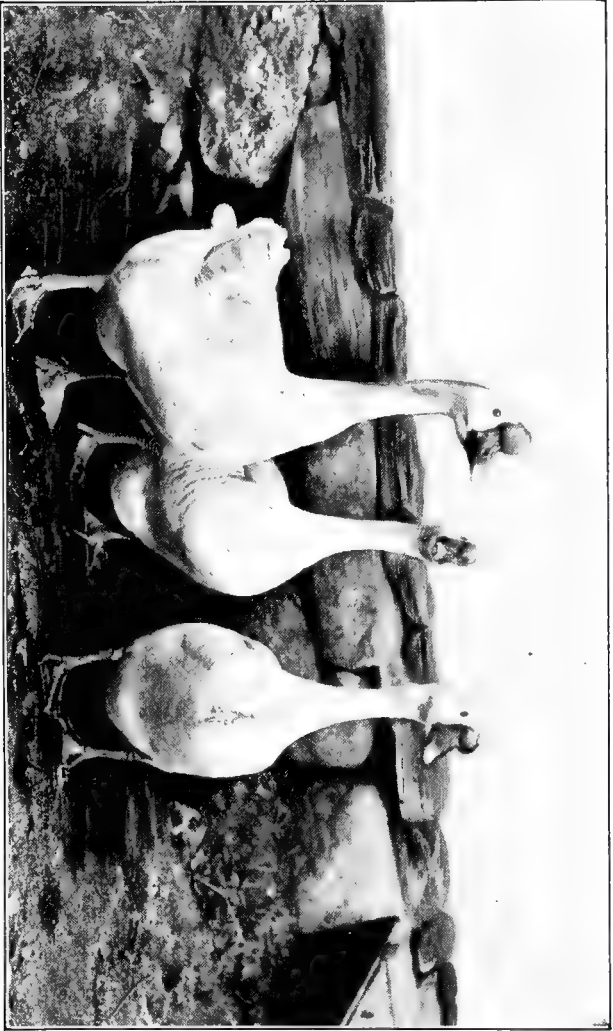

WHITE CHINESE GESE



PEKIN DUCKS RESTING IN PASTURE

either in a place which has not been used before or where the soil has been plowed or spaded. If this precaution is taken, together with the use of board floors and proper care, there may be no fear of gapes. The location should be in a good-sized yard with grass and some shade, or else at a little distance from where the old flock is in the habit of running. To feed young chicks among a lot of hungry fowls is provoking, to say the least. An orchard is an excellent place to put the coops, as there they may have plenty of shade and plenty of range.

It is advisable to watch the hatching closely when it is about time for the young to appear, so the chicks may be removed to a warm place and wrapped in flannel or cotton until the hens are ready to come off. If this is not done and the hatch is uneven, the mother hen may become restless and either trample some of the chicks to death or leave with some and cause the remainder to perish. If good coops have been provided the chicks may be placed there with the hen as soon as they are all out and dry and can walk.

By this time they will begin to pick around for something to eat. Crumbs of stale bread may be given for a day or two. There are many things recommended for young chicks, and no one thing may be said to be best. A bread made by mixing three parts of corn meal, one part wheat bran and one part wheat middlings, baked until it is crumbly, and to which is added a little hard-boiled egg, is one of the best things for the first few days. After that chief reliance may be placed in a prepared chick food made up of cracked corn and various kinds of small grains. It is always ready and handy

to feed. Care must be taken to avoid overfeeding any kind of sloppy mixture, as much trouble has been caused in that way.

After four days, if the ground is dry and there is warm sunshine, the old hen may be let out and allowed to take a hunt with her brood. There is nothing like a sensible mother hen to look after the wants of her young. She will scratch faithfully and find just the kind of grit, small seeds and grass conducive to the proper development of the baby birds. With good foraging ground, supplemented with good food, it will be pleasing to see how bright and smart the young chicks will be and how they will grow day by day. Of course, fresh water should be supplied them every day.

When the mother hen is first turned out it is well to look after her and see that she gets back in her place before night. She may be found sitting on her brood in some corner, but if she is not wild it will be no trouble to get her to coop and in a night or two she will go to it of her own accord.

## CHICKENS IN HOT WEATHER

If the best results are desired, growing chicks should have proper care and attention during the summer months. It is important that clean and comfortable quarters be provided for them. Coops so placed as to get the sun in the morning and shade in the afternoon will be found desirable. This will prevent the coop from getting so thoroughly heated as to make it uncomfortable at night. Habit is strong in chicks which will return to an overheated or foul coop, when they should be in more comfortable and roomy quarters. They may

not die, if left to themselves; they will probably take to the fences or trees to escape from such a coop, but for this lack of care in their owner's part, they will pay the penalty in poor growth, lack of vigor and weakness, either at that time or later.

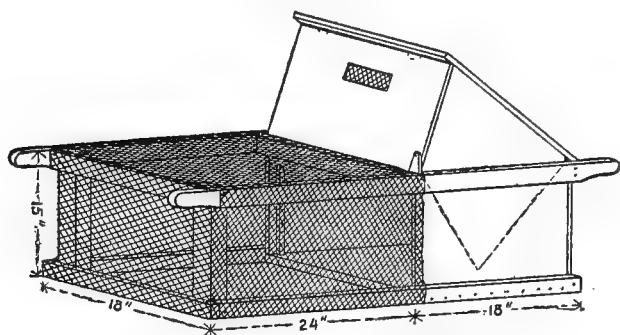

PORTABLE COOP AND RUN

Coop, raised during day. Triangular latch holds top up.

It is well to remember that chicks grow fast, and a coop that had been plenty large enough for a brood when young will soon become too small, and overcrowding, and, in consequence, injury to health and growth will result. More room should be given at once if overcrowding is noticed, either by providing larger coops or dividing the broods. If coops and brooders are cleaned frequently little reason will be found to complain of that great pest, lice, which otherwise might be the cause of weakness and stunted growth. Not only is it important that the coops be kept clean, but the ground in their immediate vicinity should not be allowed to become foul.

It will be found best to give growing chicks as

much range as possible. If necessary to confine them, have as large yards as can be provided. Chicks should be fed apart from the older fowls. If all are fed together they will be apt to get an insufficient amount of food and the older fowls will receive too much and, in consequence, become too fat. The chicks seem to get plenty of grain on account of their activity, but when one thinks that this activity is, in a great measure, caused by their having to dodge the pecks of older fowls, it will be seen that they are not allowed to pick up as much food as they have the appearance of doing. Regularity in feeding is another important matter. If chicks are fed at certain times when on free range, it will be found that they will be near or about the feeding place at that time and all will share alike; whereas, if fed at any old time, some may have wandered off in search of bugs and insects and, therefore, miss their portion.

After a certain age a mash is a help to the development of the growing chicks. If given for a change and in moderation, however, it will be found best to confine one's self in the main to dry feeding as in the earlier stages of a chick's life.

One of the most important things to be considered during the summer is the water supply. The water should be kept in some vessel or fountain that will prevent the chicks from walking in it, or else it should be changed frequently. The fountain should, of course, always be placed in a shady spot.

Late chickens, when properly cared for, often make as nice fowls and lay nearly as soon as the earlier ones, as they have the advantage of settled warm weather and generally not so much dampness.



Set the hens all in the same room or building, in which they can have a good dust bath every day, and which can be closed to make sure that all return to their nests. Feed only corn and clean water and take them off at a regular hour each day.

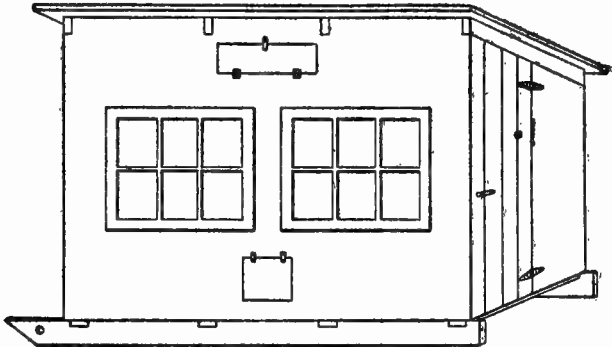

PORTABLE COLONY HOUSE

Sills are runners, to which frame is bolted. Walls, tongue and groove siding. Floors tight. Ventilators and other openings screened to keep out rats, etc. Size 6 x 8 feet, 6 feet high in front, 4 at back. Painted. Cost about \$15.

## CARE OF LITTLE CHICKS

As the chickens hatch, remove them from under the hens every hour or two to make sure that none get trampled to death in the nest. When at least one day old, feed millet seed and oatflake five times a day and give clean water as often. One of the safest ways to vary this diet later is a johnnycake made of two parts cornmeal, one of middlings and a fourth part made up of oilmeal and meat scraps. Stir in some finely broken egg shells so that the food will not harden in the crop, and feed dry.

Have a board floor to the coop, so a heavy shower some night will not drown the chicks. Always close the coop tightly at night to exclude rats. After the chicks are a week old let the hen out with them every day a few hours while it is dry. Never turn them out in the mornings until all dampness has left the ground.

A few days before hatching rub sulphur thoroughly through the hen's feathers and sprinkle it in the nests. When the chicks are two days old examine them for lice. Unless accustomed to this, one may decide that a poor little chick which really is being eaten alive with them is comparatively free from lice. It must be learned what to look for and how. The large gray louse is the most common.

Dip the finger in kerosene and draw it first around the chick's neck, next to the body. This will start the lice all on a run for the head, ears and under the bill. Follow them up with the oil and every one touched by it will be killed instantly. It is not necessary to saturate the down, and care must be exercised to get no oil in the ears or the eyes. This treatment will not hurt the chicken in the least. In 15 minutes he will be as dry and fluffy as ever if he is not allowed to run directly under the hen. That would prevent evaporation and he might get a blister. This is greatly to be preferred to kerosene mixed with some other grease, as that prevents rapid evaporation. Never grease the chicks under the wings, as they are too sensitive there.

## CHAPTER XI

### **Market Methods**

Coops should be high enough to permit the poultry to stand easily upright without bending their legs and with space enough between slats to pass their heads through. The coops should be strong but light; heavy wood can be dispensed with if long nails are used. They should not be so large as to be awkward and cumbrous to handle. Where large coops are used they should have partitions, so that when the coop is accidentally tilted the whole weight of poultry will not be thrown upon those at the side and end. The poultry should have plenty of room. Crowding too many into a coop causes loss by suffocation. Only one kind or size of poultry should be sent in a coop.

All poultry reaching market the following day after shipment should be fed only lightly before being placed in the coop, so as to avoid any infringement of the law regarding food in the crops of poultry. Western and southern poultry is generally shipped in carloads accompanied by a man to feed and water the fowls. The first day or two after the car starts the fowls should be fed lightly; after they have become accustomed to their new quarters the quantity of food may be increased with good results. Overfeeding on the start makes the fowls dumpish and sick, from which they do not recover on the journey. The rule of New York is to let the coops go with the poultry free. Where the patent wire cars are used either new or second

hand coops are furnished at the shipper's expense. The principal market days are from Monday to Thursday inclusive. There is seldom much trade on Friday or Saturday.

Shipments of live poultry are seldom made during cold weather. They do not pay well then because they compete with dressed fowls. April to October is the usual season. Live poultry should pay as well as dressed, especially if the shipper has little or no skill in dressing.

### MARKING AND SHIPPING

For the best results the cover of every package should be plainly and neatly marked with the gross weight and tare, or number of dozens, pairs, or pieces of and the kind of contents, whether broilers, roasters, ducks, etc. The name, initials, or shipping mark of the shipper and the address of the firm to which the packages are sent should also appear. Where large lines of goods are shipped, simpler marks may be used by agreement. The shipper should always get receipts from the transportation company, and send immediately full advices by mail, with correct invoice of shipment. When poultry and game are forwarded by express, put a letter of advice in one of the packages, and mark plainly on the outside, "Bill," advising by mail also. Nothing is so vexatious to a commission house as the receipt of consignments not properly marked and advised. Every shipper who designs to make a business of forwarding good articles should have a brand or mark of his own. Thus he may establish a reputation for his goods. Perishable articles should be shipped so as to arrive not later than Friday morning.

None but very neat packages, as light as is consistent with carrying the contents perfectly, should be used. In a lot of goods all the packages should be of uniform size, shape and style. In shipping articles that require air, ventilation must be provided. When articles are sold by the package only standard size should be employed.

### DRESSED POULTRY

The great end to aim at is to have the poultry reach market in perfect order—firm, bright and sound—and that it may present as handsome appearance as possible. There is almost always abundance of stock of inferior quality and unattractive appearance, the value of which would have been greatly increased by more care and attention to details in preparing for shipment. Shippers who get their goods to market in uniformly fine order, and whose study of all the details of killing, dressing and packing result in uniformly fine quality, soon acquire a reputation for their goods among buyers. This is of great value to shipper and buyer.

An ordinance in force in New York prohibits the sale of all turkeys and chickens the crops of which are not free from food. This law makes it imperative that poultry should be kept from solid food long enough before killing to insure the crops being empty. It is best to keep from food 12 to 24 hours before killing, but during this time the poultry should have plenty of water. In case any fowl should be found to have food in the crop after killing this food should be removed by making a clean-cut incision in the back of the neck and the contents worked out under the skin. Never try to force the

food out through the mouth, as this is likely to cause discoloration.

There are two methods of dressing—dry picking and scalding. As a general rule the chickens, fowls and turkeys that command the highest prices are dry picked. But by no means do all dry-picked lots sell higher than scalded. Lean poultry always looks much thinner when dry picked than when scalded and plumped, and thin poultry commands more when scalded than when dry picked. For this reason chickens and turkeys should be dry picked only when very fat and of fine quality. Ducks and geese should always be scalded.

The method of packing poultry for shipment depends upon the weather and the purpose of the shipper. Stock intended to be frozen for future use is always packed dry. That intended for immediate shipment and use may be packed dry or in ice, but should be packed dry only after settled cold weather.

### SELECTION OF STOCK FOR MARKET

For market no poultry should be killed which is not of reasonably good size and in good condition. Small, thin, framy turkeys, such as are often received very early in the season, are always a drug in the market and are unprofitable. Even in September, none which weighs less than 7 pounds should be dressed, and later 8 pounds should be the bottom limit. Spring chickens should never be killed before they attain a weight of at least 1 pound. This size is profitably salable only very early in the season; as soon as supplies become at all liberal,  $1\frac{1}{2}$  pounds. This weight should be the bottom limit.

**Spring ducks** should be kept back until almost full grown. Commission houses receive full-grown spring ducks from the great duck farms very early in the season, and these bring high prices. Western packers, seeing the high quotations for these, often send very small, young ducks about the weight of broiling chickens. Such are unsalable at any reasonable price. Spring ducks are never used to broil, always to roast, and there is no call whatever for stock weighing less than 3 pounds.

### KILLING AND DRESSING

Immediately after killing, the feathers must be carefully and very cleanly removed, taking especial pains to avoid tearing the skin. When dry-picked poultry is to be packed dry for cold-weather shipment it should be hung up head down in a cold place (but not cold enough to freeze), and left until thoroughly cold and dry. Any animal heat left in the body when packed, and any moisture on the skin, is sure to cause bad condition in a short time. When the dry-picked poultry is to be packed in ice for warm-weather shipment it should be thrown into water of natural temperature and left there for 15 to 20 minutes, then removed to ice water, where it should remain eight to ten hours, when it will be ready to pack.

For scalding, the water should be just at the boiling point, but not actually boiling. The birds held by legs and head should be immersed and lifted in the water three or four times. Immediately after scalding chickens and turkeys remove the feathers, pin-feathers and all, very cleanly and without breaking the skin. After scalding wrap ducks and geese

immediately in a cloth for about two minutes; then the down will roll off with the feathers.

All scalded poultry should be "plumped" after picking by dipping for about two seconds in very hot water—just under the boiling point—and then thrown into cool water of the natural temperature, where it should remain for 15 or 20 minutes. When the scalded poultry is to be packed dry for cold-weather shipment it should be taken from the first

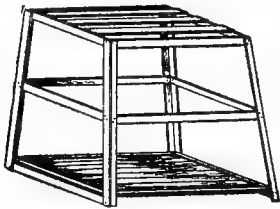

FRAME OF SHIPPING COOP

cold plumping water and hung up by the feet until thoroughly cold and dry; it will then be ready to pack. But when it is intended to pack in ice for warm-weather shipment, the poultry should be transferred from the first cold bath to another of colder but not ice-cold water and remain there for half an hour to an hour, after which it should be placed in ice water and left for eight to ten hours, when it will be ready to pack.

### PACKING

Barrels and cases holding about 200 pounds are commonly used; the latter are the best for turkeys and geese. If any packing is used it should be only clean, dry and hand-threshed wheat or rye straw. A layer of straw should be placed in the bottom of

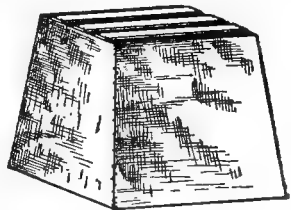

COOP COMPLETE

Frame and floor of light material. Sides of strong canvas. Size to accommodate fowls comfortably without stooping.



the package, then alternate layers of poultry and straw, stowing very snugly, backs up and legs out straight, filling so full that the cover will draw down firmly upon the contents. Some successful shippers use no packing, filling the packages solidly full of poultry, but using waxed or parchment paper around the sides, bottom and top of the case or barrel and between the layers of poultry. If this method is adopted the utmost care should be taken to have every fowl perfectly dry before packing. The use of straw packing is generally preferred and is considered safe, unless goods are destined for storage. All blood remaining about the mouth and head should be removed with a damp cloth.

For shipment in ice only poultry or sugar barrels should be used; if the latter, they should be thoroughly washed with hot water to remove all traces of sugar. A layer of cracked ice is placed in the bottom of the barrel and alternate layers of poultry and ice until the package is nearly full. Over the top layer of poultry a layer of cracked ice is also placed, then a piece of burlap and again a layer of cracked ice, topped off with a large chunk of solid ice, fastened in place with a piece of burlap secured under the top hoop. The poultry breasts are down and backs up, with legs out straight toward the center of the barrel, making a ring of fowls side by side around the staves, backs sloping inward so that the next layer of ice will work in between the poultry and the staves. The middle of the layer may be filled in with the fowls at will.

Poultry frozen during the winter for later use should always be dry picked. Only the very choicest goods should be selected for this purpose, and extraordinary care must be taken that the stock

be thoroughly cold and dry when packed. The treatment varies according to circumstances of weather, etc. Probably the best results are obtained when the stock can be frozen by natural outdoor temperature. But in seasons and localities where this is impossible the freezer may be used successfully. Only cases of planed, well-seasoned lumber should be used. For old tom turkeys the size in popular use is 36 by 22 by 18 inches, and for young toms 36 by 22 by 15 inches; these should be of inch lumber. For chickens, ducks and geese the size is 30 by 20 by about 10 inches, or deep enough to allow for two layers, made of  $\frac{5}{8}$ -inch lumber. Two layers of poultry should be packed in each case. The poultry is stowed snugly and closely so as to present as regular and handsome appearance as possible. Turkeys should be packed backs up and legs out straight. Chickens and ducks and geese should have the breasts down on the bottom layer and up on the top layer. Old toms should be packed separately, never with young toms and hens. Old fowls and young chickens should never be packed together. Each should be packed separately.

### COLD-STORAGE POULTRY AND EGGS

When stock is frozen in natural outdoor temperature the cases may be filled at once when the thermometer is below zero, but if above zero only one layer should be frozen at a time. No packing material whatever should be used and the packer should be sure to protect from wind while freezing. When frozen solid the stock should be put away and kept where it will not thaw out, preferably in

cold storage. When the poultry is to be frozen artificially the cases may be filled full and placed at once in the freezer.

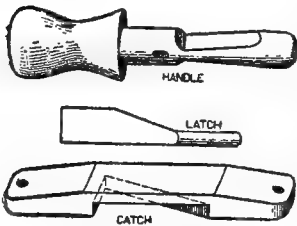

DETAILS OF LATCH

In this case it is well to construct the cases so that a slat in the sides of the box may be removed and left off until the stock is frozen solid. The quicker the freezing the better. In the freezer the cases should be separated by slats to permit free circulation of air around them. Some packers get

excellent results by freezing poultry separately and packing after. Some of the very finest frozen poultry is handled in this way at nearby points, and is not packed at all until ready for market, when it is packed in straw and shipped for immediate sale before warm weather. But for large lots which have to be placed in storage again upon arrival in market, it is best to pack in cases before freezing.

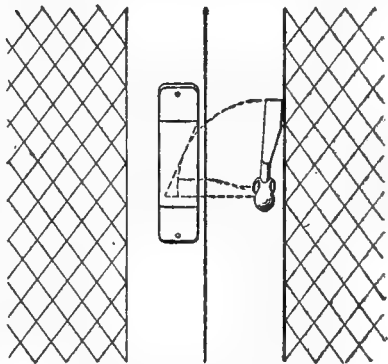

LATCH FOR DOOR OR GATE

Oak handle, 8x2x1 inches; latch, 5x1 x 3/8 inches; catch, 8x2x 3/4 inches. One-inch hole in door for handle 3 inches from edge of door. Hole 3/4-inch in handle for latch. Assemble parts and peg together.

While the principle of cold stor-

age is correct, its abuse is responsible for much unfair discrimination against cold-storage eggs. Let it be granted that the cold-storage people are not in business for fun or to see how long eggs can be kept and still pass as eggs. They wish to make a profit. If eggs are not good when removed from storage these people must lose money because they can't make sales. Experience has taught them that eggs can be kept in practically the same condition as when received, but storage does not improve the quality of eggs improperly handled before reaching the warehouse.

Much of the trouble arises in the bad methods of handling before the eggs reach the warehouse. This largely occurs where eggs are held for a raise of prices. Wherever this is done, under ordinary cellar storage conditions, whether on the farm or in the country store, there is always deterioration. If this common storage and rehandling were eliminated, and were eggs put in cold storage with less delay after being laid, farmers would be able to command higher prices, because losses would be less serious, and the disfavor in which storage eggs are held would be largely reduced. It is to his interest, therefore, that the farmer devise plans for getting eggs to the nearest cold-storage warehouse, unless it is possible to develop a satisfactory local market for fresh eggs.

In cold-storage warehouses poultry is kept continuously at a temperature considerably below zero, even as low as 10 below. At such a temperature no changes occur, and the birds remain sweet and wholesome indefinitely. The meat of such fowls, if properly handled after removal from cold stor-

age, will be found unimpaired in flavor and indistinguishable from that of freshly killed birds.

## EGG MARKETING METHODS

Selling eggs is one of the handiest ways to get a cash or trade return for farm produce, and wherever farmers can increase the efficiency of the machinery which produces and handles eggs, they will put hard cash into their pockets. In Kansas, which may be taken as one of the typical egg-producing states, the methods in vogue are generally bad. In order to determine how improvements could be made, A. G. Phillips sent a long list of questions to more than 70 egg handlers for comments. They represented an estimated annual output of over 900,000 cases of eggs. Thirty-three of these men purchased by the method called "case count" the year round. Forty do not.

By case count is meant that eggs are counted just as they are received. During hot weather, that is between July and September, the usual plan is to buy "loss off;" though some buy in this way from May until December. The term "loss off" means that inferior and cracked eggs are not paid for. When eggs are bought in the loss-off way, a difference of 1 to 5 cents in price is made, the average being about 2 cents.

During the hottest month 58 buyers purchased 100,000 cases or more. During that month the

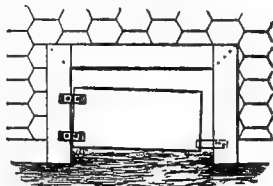

HEN GATE

Hinged gate hung to open in to the poultry yard and to swing shut when hen enters.

usual run of "rots" is from 10 to 20 per cent, though some buyers who have a superior trade report 5 per cent, and others who have an inferior trade, 75 per cent loss, due to spoiled eggs. During the period when buyers purchase in the case-count way, 57 buyers reported a loss of from one to three dozen to the case, and only seven men reported a smaller loss. The average is at least two dozen to a case for the year round.

Of the more than 70 buyers 69 say that they could afford to pay a higher price if they did not have to allow for these losses, and not one of them says he could not afford to pay a higher price. The advance in price ranges from 1 to 5 cents and averages 2 cents. Sixty-eight men say that the usual run of eggs they buy is of only fair quality, and 37 report that the cause of spoiled eggs is due to the farmers not giving the eggs proper care. Thirty-three say that both farmers and storekeepers are to blame because they hold for higher prices.

Twenty-three buyers declare that they could afford to buy loss off the year round, but 40 claim they could not. The ayes say that it would be justice to all, that they would get a better grade of eggs and the farmers would get more money. The nays say that competition prevents, that the eggs are good enough in winter, that they have no market for seconds, that the farmers are dissatisfied and that hot weather prevents. Sixty-three buyers say that if a farmer or a community of farmers would follow instructions as to the kind of eggs best to sell and would ship only first-class eggs, they could afford to pay a premium upon the eggs above the regular price. Only five buyers claim

that they could not. The price ranges from 1 to 5 cents, with an average of 2 cents.

## HOW TO IMPROVE EGG MARKETING

Buyers offer many suggestions as to the way farmers should handle eggs for market. Farmers should be less intentionally careless; they should not wash the eggs; they should keep eggs not strictly fresh at home; they should market their eggs frequently; should learn the difference in price that could be obtained for good eggs over bad ones; carefulness in details should be practiced; the nests should be kept clean; the eggs kept in a dry place and covered when being brought to town; the cocks should be disposed of at the end of the breeding season; the eggs should be gathered frequently, and be graded; and that farmers should recognize that when they trade eggs with the merchant, they are doing so almost always at a loss.

From the foregoing answers it is evident that there is considerable loss of money to farmers each year. One year, to use Mr. Phillips' figures, when the output was 146,381,180 dozens of eggs marketed, an average loss of two dozen rots to the case would mean a total loss of 9,758,745 dozen eggs. These were irretrievable losses, partly on account of carelessness. This number does not include eggs classed as seconds. There is not the least doubt that 50 per cent of the rotten eggs could be eliminated, and if this were done, taking eggs at 16 cents a dozen, a fair average price for the year, the farmers of Kansas would have saved nearly \$780,700; the complete elimination of bad eggs would increase the income by over \$1,500,000. If

the second-class eggs could be sold as first-class, a very considerable additional sum could also be saved. No one viewing these figures can fail to see the advantage of taking the trouble to adopt better methods.

It is hardly reasonable to expect anyone to improve his business conditions unless he can realize a financial benefit therefrom. Everyone likes to produce the best of anything. But if he can make more by selling an inferior grade, it is natural and reasonable that he should do so. In the matter of handling eggs, however, improvements mean more profit and should, therefore, be made. Three ways are open whereby poultry

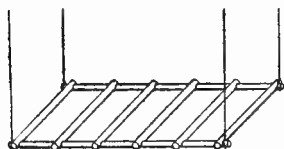

SUSPENDED ROOST

raisers may market eggs: First, by selling to the buyer who either ships without grading or candles and disposes of the stock according to quality. By this method a producer is able to take advantage of

the intense competition generally present among local buyers that raises general prices until some merchant complains that prices are too high to leave any profit after the eggs have been candled.

### WILL IT PAY TO IMPROVE

Number one eggs which farmers bring every week should command more than older eggs. At present they do not, and the tendency is to let the care of the eggs slide. The average increase would be  $1\frac{1}{2}$  to 2 cents a dozen. If the average Kansas hen produces 100 eggs in a year, the farmer who



keeps 200 hens would thus gather 20,000 eggs yearly. If one-fourth of these were consumed at home, 15,000 or 1,250 dozen, would still be salable. A premium of 2 cents a dozen on this lot would mean \$25. Whether this amount would be worth the slight trouble taken to secure it is, of course, a matter for each individual to decide for himself.

The way to get the buyer to pay a premium is a question to be decided. If the storekeeper will not do it he should lose the trade and the farmer should ship to a nearby large buyer who will be willing, even glad, to get this trade, and he will treat his customers in the best possible way so as to hold it. Such a buyer will probably quote market prices only until he is satisfied that the quality is as represented. Then he can be made to pay the desired premium. There is no reason why several farmers in a community should not ship eggs together in lots of 15 dozen or more and work up a business large enough to make a buyer want to hold their trade.

## **CO-OPERATIVE POULTRY ASSOCIATIONS**

could easily be managed where hens are numerous enough to make a profit for all concerned. The following suggestions will be of benefit to such prospective associations. A number of farmers who are interested enough to stick together should form an association and should maintain their compact whether they lose a little or not. It is characteristic of buyers to try to break up such organizations by various tricks, and farmers are too prone to condemn organization hastily; that is, before they

have given it a thorough trial. After they have passed over the first rough water and are living up to their agreements, keeping their grades well, they can make money if properly managed. They should be organized under a simple constitution, which shall give the name, object, membership dues, officers and their duties, meetings and rules. Under the rules should be given the grades of eggs and of poultry, and the proper way to handle, mark and market. The co-operative system can be made highly successful, even in small communities.

Another way that farmers can market eggs to advantage is to sell at retail or at a slight premium to a hotel or a restaurant, where large quantities are in demand and yet where high quality is sought to cater to an exacting table. A farmer who keeps 300 White Leghorns says that this method of supplying one good restaurant netted him a clear profit of over \$1 a hen during a year.

The third method is to sell to a private trade by peddling to small customers and selling at a premium. The best instance I know is that of R. P. Ellis, who does business in Brooklyn, N. Y. Mr. Ellis has not only worked up a considerable trade, but has been obliged to associate several farmers with himself in order to supply the increasing demand for his output. His method is based on the general principle that the nearer the producer can get to the actual consumer the higher he can sell, because he can eliminate most of the middlemen. Besides this, the sooner the egg can be placed on the consumer's table after being laid and the more pleasing its appearance, the better will be the price.

A controlling factor in all marketing is the dis-

tance the consumer is from the source of supply. In large cities where eggs are purchased from grocers after being handled by wholesalers, commission men, shippers and country gatherers the prices which really fresh eggs bring are considerably higher than in the small towns.

It stands to reason that if the purchaser can raise chickens in the country and can grow much of the food they need and then sell his eggs in the large city direct to the consumer he will get the maximum profit. Because of the co-operative arrangement Mr. Ellis has made with farmers associated with him, all clear about \$2.50 a hen annually, whereas \$1 a hen is the general estimated income on most egg farms. The rules under which their operations are made may be summarized as follows:

Eggs must be spotlessly clean and of uniform size and color. This means that all the laying stock must be pure bred, of the same breed, for in no other way can uniformity be secured. For this purpose the White Leghorn stands pre-eminent.

The representative or salesman must be patient and courteous with the skeptical, and willing to submit produce to a comparative test, confident of the outcome. The price is never cut to secure a customer. It is well to have a scale of prices printed on the inside of the cover of the egg box, stating what will be charged each month of the year. The salesman is always politely indifferent to the current prices on eggs, and tactfully makes people feel that the eggs he sells are in a class by themselves. They really are a superior article. The producer believes in himself and in his product. Faith is the essence of all salesmanship.

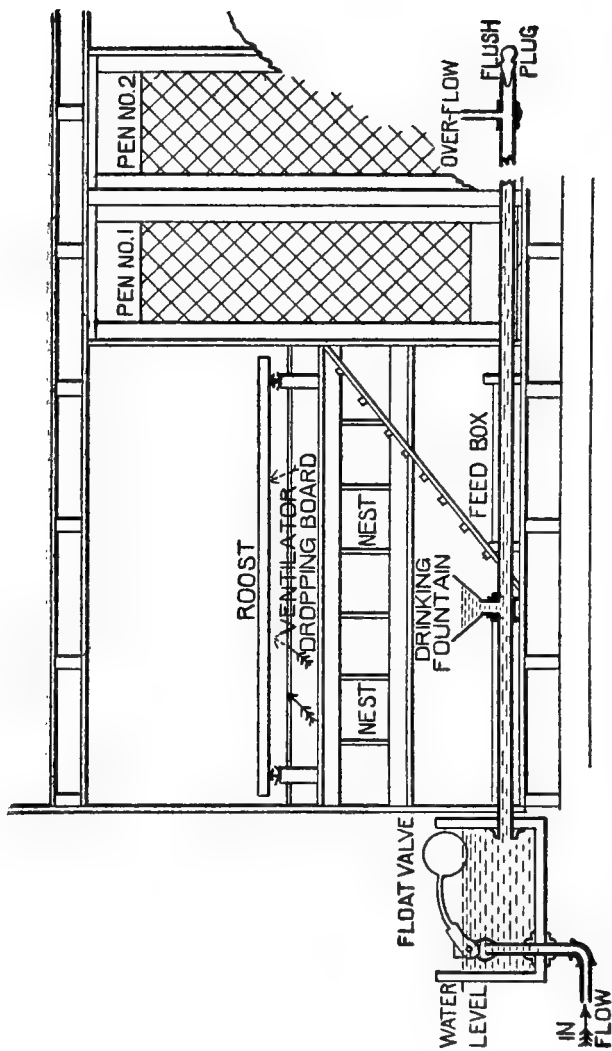

CROSS-SECTION OF POULTRY HOUSE

Main feature watering system managed by float valve at left. Slight fall toward overflow at right. Flush plug drains system in cold weather.

The eggs are boxed and delivered in a style and manner befitting the pre-eminence claimed for them. Broken-down wagons and worn-out horses do not inspire the public with an abiding faith in the progressiveness of any concern. Much as some may despise it, appearance counts for a great deal in modern business advertising, especially in large cities, where an individual cannot expect to be widely known.

### HONESTY ESSENTIAL TO SUCCESS

It is necessary to be honest and not to be tempted to abuse the people's confidence. Customers are always given what they pay for, and their orders, great or small, are accorded marked personal attention. There is too little courtesy on the part of tradespeople; hence it is the salesman's cue to be different. Should he, therefore, run short of eggs, he never substitutes. Grocers do that. Mr. Ellis has a neatly printed postal notice in which he courteously regrets that the hens are not doing quite as well just now, and that he cannot fill the regular order when due, but that on such and such a date he will deliver. He leaves blanks on the cards to be filled in with dates. This pleases customers, who may be relying on getting eggs and impresses them that such eggs are not always obtainable, and hence most desirable. There is a lot in this.

It is equally necessary to be square with the associate farms. Only mutual interest can keep them together. The success of one means benefit to all, and the failure of one works an injury to all. Those who handle the selling should not seek to "hog" the profit a good private trade yields. Pass most of it along where it belongs, to the producer!

The matter of drivers of delivery wagons should receive careful attention. Mr. Ellis did not take a driver similar to the average grocery delivery boy, but has a uniformed man, or young fellow, equal in intelligence and manner to the best deliveries in the city. It pays. He pays a salary and a commission on all eggs delivered. This nets the

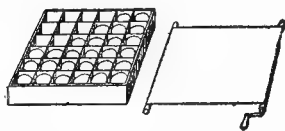

EGG-TURNING TRAY

Cloth on rollers passes over bottom of tray. Eggs turn when cloth moves.

deliveryman between \$18 and \$25 a week. It pays in the end. A discourteous, untidy deliveryman will spoil a good many dollars' worth of advertising in one day. The men who make the maximum pay do it by securing a few new customers each week.

and the commission paid them on these is much less than cost of securing a customer by publicity.

The business done is strictly cash. His prices run from 40 to 60 cents, averaging 47.8 cents to the consumer. He finds that boxing and delivering, which includes other labor, such as bookkeeping and necessary correspondence, cost 5 cents a dozen. He is spending regularly 5 cents a dozen on advertising, which in greater New York is a very expensive thing. For instance, street car advertising costs \$5 a day for 400 cars, or \$150 a month, and 400 cars barely represent the number running into one depot. In the advertising expense is included the cost of canvassing the prospective customers who answer advertisements. The proprietor himself attended to this until the business grew beyond him, when he made a careful selection of a representative.

There are over 200 cities in the United States with a population exceeding 25,000. In each of these a profitable private egg trade can be established. What Mr. Ellis is accomplishing others can do. The associated farms net between 30 and 50 cents a dozen the year round. They average better than 37 cents a dozen, 3 cents an egg, the year round.

### PRESERVATION OF EGGS

The following precautions are suggested by G. H. Lamson, Jr., of Connecticut: Keep the whole flock of hens in as perfect a state of health as possible. Give enough shell-forming food to form strong shells of uniform thickness. Make proper nesting places and keep nests clean, so eggs may not be infected while in the nests. Gather the eggs each day and keep them in a cool, dry room or cellar where the sun's rays do not fall directly upon them. Use only clean eggs and place them in the preservative within 24 hours after they are laid. Preserve only April, May and early June eggs.

As to methods of preserving undoubtedly cold storage at a temperature of 34 degrees is the best and practically the only method used commercially. But it is too expensive to be practiced on a small scale. Formerly dry methods such as packing in grain or salt were used, but these are no longer recommended, as the eggs lose much of their moisture by evaporation.

Among the liquid preservatives, water glass has been very generally and successfully used because it is reliable, easily prepared and comparatively

cheap. Water glass can be bought at most drug stores for \$1 or \$1.25 a gallon. A gallon will make 10 gallons of preserving fluid. Eggs have been kept in this mixture for three or four years without developing an unpleasant taste or smell, but when kept any longer the yolk becomes pink and very liquid. The white coagulates in the usual manner in cooking.

To preserve eggs by this method, a cellar should be used where the temperature does not go above

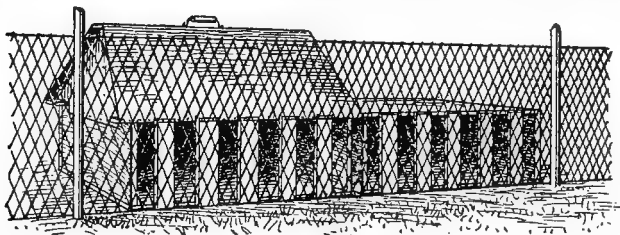

FENCE PROTECTS COOPS AT NIGHT

60 degrees. Any clean water-tight receptacle will do; kegs or stone jars are commonly used. Each receptacle should be scalded thoroughly two or three times to make sure that it is perfectly clean. The preserving fluid should be made from water that has been boiled and allowed to cool. This is mixed at the rate of nine parts water to one of water glass, and thoroughly stirred. The quantity needed for each receptacle should be mixed in that receptacle so as to insure the proper strength of solution. When mixed in one and then poured into several others there is a likelihood of getting different strengths.

It is desirable to label each crock or keg with



the date the eggs are put down. When filled the receptacle should be kept out of the sun's rays and covered with loose boards. Water should be added from time to time to supply the loss by evaporation and to keep the eggs always beneath the surface. The preservative never should be stirred. When desired for use, the June eggs should be taken first, May eggs next, and April eggs last, because their keeping qualities are different. If eggs are to be sold they should be washed.

One man who has practiced preserving on an extensive scale found that the eggs cost 15 cents a dozen to produce as an average. His market price was 18 cents during spring. The margin of 3 cents profit did not appeal to him, so when eggs came down to 18 cents in March he began preserving. He used only the eggs produced by his own flock. By Thanksgiving time when eggs are selling at 50 and 60 cents a dozen in Boston, he sold these eggs as "storage extras" at an average of 32 cents a dozen, some as high as 40 cents. As the eggs were all produced by his own hens, he could guarantee the quality. This is very important.

The cost of storing was about \$2 for 200 dozen. Had these eggs been sold in March at 18 cents they would have brought only \$36. By preserving they brought \$64, or an apparent net gain of \$28. There is, however, another way to look at this which is even more startling. As the average cost to make the eggs was 15 cents, at 18 cents there would have been only 3 cents a dozen profit, or only \$6 on the 200 dozen. By holding until prices were high he actually made 17 cents a dozen instead of 3 cents, or a total profit of \$34.

It would not be advisable to preserve eggs on a large scale at first. There is a good deal to be learned before one can venture upon this business. The family supply will be enough to lay down as an experiment. After a year or two of experience and confidence will be soon enough to start preserving for the market.

### NEW YORK STATE EXPERIMENTS

At the New York experiment station a number of methods that could be used with little expense on a small scale for preserving eggs, and also some modifications of these methods, show that no method of dry packing gives satisfactory results whether the eggs are turned regularly or not. The best results were secured by keeping the eggs immersed in solutions either of lime, lime and salt, water glass, from 10 to 20 per cent solution, or a proprietary solution consisting largely of water glass. On the whole, preference is given to a solution of lime and salt to which a little boracic acid was added of a specific gravity somewhat lower than that of eggs. The common materials can be cheaply obtained in pure condition, and the preserved eggs were easier to clean than those from more costly solutions which gave no better results. Though, of course, no preserved egg could grade with a fresh one, little difference in quality of eggs, as tested by many individuals, could be detected between those preserved in the few efficient solutions.

### EGG GATHERING

Clean eggs always sell at higher prices than soiled ones. In order to secure them, eggs should

be gathered at least twice a day, and oftener when the ground is muddy. This applies especially to the summer weather. Eggs quickly begin to decompose when the temperature is high and should, therefore, be removed as soon as possible to a cool dark place.

Fertile eggs begin to deteriorate sooner than sterile ones; hence, unless needed for hatching, hens and pullets should be kept by themselves. Fertile eggs, even when fresh laid, may be considered as already started in development. For this reason it is highly desirable that the eggs be gathered frequently, because the warmth of the bodies of several hens on the nest will hasten development of the embryo, and if eggs are allowed to stay in the nest for several hours under such conditions they cannot be considered as strictly fresh.

Until marketed, the clean, fresh eggs, frequently gathered, should be kept in a cool place. Even though this place is clean and cool and it is not dry, the eggs are likely to be injured by mold. If they become damp and then happen to touch colored material they are likely to become stained. The best way of holding is to store the eggs in good egg cases in a cool, dry place above the floor. Prior to marketing, the eggs should be graded. All small, dirty, stained eggs as well as those which have been in the incubator or which are doubtful or rotten should be removed. The small and dirty ones, if fresh,

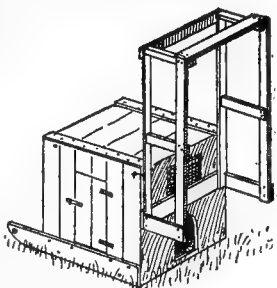

READY FOR MOVING

are just as good as the large, clean ones, but they will not sell as well, and if sent to market will injure the price which would be paid for large eggs. Large eggs, among which small ones are mixed, will sell for the price of the small ones and the buyer, after grading, will sell the large ones at advanced prices and the small ones for what he paid, or better. Therefore, small and soiled eggs should be used at home. Never should eggs be washed, because washing injures the keeping qualities.

Every egg from a stolen nest, unless its freshness

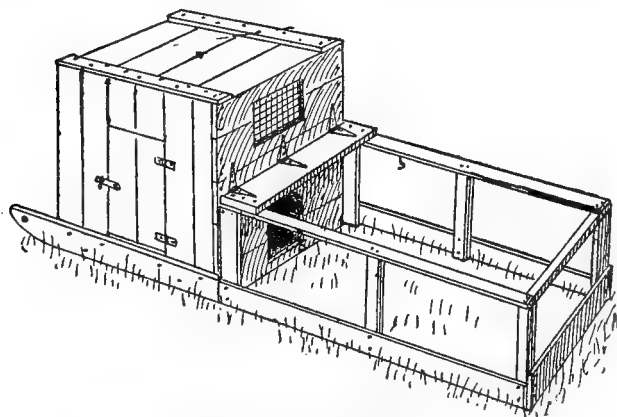

PORTABLE COOP AND RUN

Packing case coop and wire fence covered run.

is unquestionable, should either be thrown away or used at home. The man who wishes to build up a trade cannot afford to risk his chances by letting any such eggs go to market. Eggs handled as suggested should be marketed two or three times a week, oftener if convenient. When so many

trips cannot be made, it is well to co-operate with some neighbor to go on alternate days. In autumn and spring, eggs should be marketed not less frequently than once a week.

It is bad policy to hold eggs in the hope of advancing prices. Evaporation always takes place and the chances are that the grade and the price will be lower than if the eggs are marketed at once; besides, the man who gets the reputation of marketing frequently will always command the respect of his buyers. In hot weather the cases should always be covered to protect them from the heat.

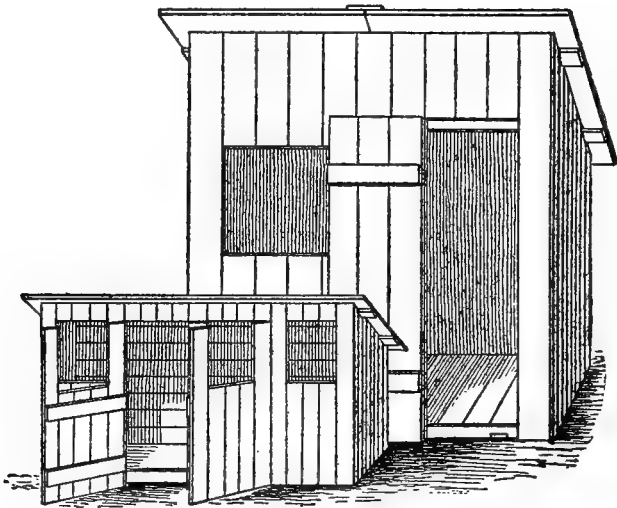

KNOCK DOWN POULTRY HOUSES

For tenant houses, whose sides, top, floors and roofs bolt together are convenient for moving from farm to farm.

## CHAPTER XII

### **Essentials of Poultry Fattening**

Crate fattening of market chickens, which has recently been growing in popularity, can be carried on with profit by almost any farmer, says F. C. Elford of the Ontario experiment station. The work is simple; chickens gain in live weight  $1\frac{1}{2}$  to 3 pounds and each can be sold for a much higher price than lean ones because they supply, weight for weight, three times as much edible meat and of superior quality. The breast meat is the most palatable part of the chicken, hence large-framed chickens with prominent breast bones cannot be satisfactorily fattened. The legs, largely composed of sinews, the meat of which is inferior, should form as small a proportion of the weight as practicable. Feathers on the legs are an objection, also black or dark-colored shanks and any development of the spur in cockerels.

Color is secured by feeding mashes, composed mainly of ground oats and skim milk. Smallness of bone, head and comb, and a minimum of offal, are important requirements. Plump chickens of any weight up to 5 pounds each dressed are more readily disposed of than large fatted chickens; 4 pounds is the preferred weight. Early chickens should be marketed either as broilers, weighing 1 to  $1\frac{1}{2}$  pounds each, or roasters, weighing 3 to 4 pounds. High prices are generally paid for such.

In crate fattening pure-bred chickens make greater gains in live weight than scrubs, and the

cost of feed for a pound of gain is less. At four months, the pure breeds are fatted, of uniform quality and appearance and ready for market. At no age are scrub chickens as salable as pure breds. The type of fowls to be selected can be had in Plymouth Rock, Wyandotte, Rhode Island Red and Buff Orpington; or if preferred, in a medium sized fancier's breed. Plymouth Rock or Wyandotte may not be satisfactory on account of great size, heavy bone, length of leg, or narrowness of body. Hence, it is of primary importance to have a definite conception of the proper type to select. The breed is of secondary importance.

### DESIRABLE TYPE OF FOWL

Table type fowls should conform to the following standard: Mature weight, cock, 7 to 8½ pounds; hen, 5½ to 7 pounds; shape of body, broad, blocky and of medium length; breast, carried well forward, full and broad, of medium depth; breast bone, long, straight, not deep nor pointed at the front; legs set well apart, short, stout, white or yellow, without leg or foot feathering; head, medium size; comb and wattles small; plumage, close feathered preferred; color not important; color of flesh unimportant.

To have chickens plump and well fatted, at the most profitable age, they should be placed in fattening crates when three to four months old. This does not mean that chickens cannot be fatted profitably when more than four months old; suitable market chickens of any age will show gains. It is advisable to use fattening crates, but if only a small number of fowls are to be fatted, packing boxes of

suitable dimensions can be adapted for the purpose.

In a series of experiments in fattening at the Canadian experimental farm, a gain of  $2\frac{1}{2}$  pounds each was made in a total of over 350 birds of large and good breeds. The average cost for food consumed was  $5\frac{1}{4}$  cents a pound of increase in live weight. The ground grain was valued at \$1.20 for 100 pounds and the skim milk at 15 cents 100 pounds. Oats finely ground, or with the coarser hulls sifted out, should form the basis of all the grain mixtures; ground corn fed in excess results in yellow flesh of an inferior quality; ground peas impart an undesirable hardness to the flesh. Ground oats, buckwheat, barley and low-grade flour are the most suitable meals for fattening.

### FEEDS FOR FATTENING

Some satisfactory meal mixtures are: 1. Two parts ground oats, two parts ground buckwheat, one part ground corn. 2. Equal parts ground oats, ground barley and ground buckwheat. 3. Two parts ground barley, two parts low-grade flour, one part wheat bran. The ground meal should be mixed to a thin porridge with thick, sour skim milk or buttermilk. On the average, 10 pounds of meal require from 15 to 17 pounds sour skim milk. A small quantity of salt should be added to the mash. When sufficient skim milk or buttermilk cannot be obtained for mixing the mashes, a quantity of animal and raw vegetable food should be added to the fattening ration.

It is necessary to feed lightly the first week. A small quantity of the fattening food is spread along the troughs, and as this is eaten more food added,



but not as much as the chickens would consume. The food should be given three times a day, and, after feeding, the troughs cleaned and turned over. After the first week, feeding twice a day as much food as the birds will eat is practiced. Half an hour after feeding, the feed troughs should be cleaned and turned over. Water twice a day and grit two or three times a week should be supplied. Chickens should remain in the fattening crates not longer than 24 days. Some chicks will fatten more readily than others. These should be picked out a week before finished and a little beef tallow, shaved into the trough, given with the mash. About 1 pound tallow to 50 or 60 chickens daily, is ample. Before being placed in the crates the chickens should be well dusted with sulphur to kill the lice, and again three days before being killed. Chickens should be starved 24 hours before killing to prevent food remaining in the crop and intestines; such would decompose and spoil the flavor of the birds. Several hours after feeding give water.

### METHOD OF KILLING

Sticking in the mouth is the usual method of killing. The large arteries at the sides of the neck, just below the ears, are cut by a couple of quick motions inside. The blade is then forced through the roof of the mouth into the brain. This makes plucking easier, since it relaxes the muscles. The bird must hang head down till plucked. As the bird hangs on a level with the operator's chest, the wing is grasped between the thumb and first two fingers of the left hand, holding the neck between the third and little finger. The large wing feathers

are removed with the right hand, and also the stiff feathers at the shoulder joints. Tail feathers come next, with one quick twisting motion. The right hand is then passed rapidly down the back, from rump to neck, removing the feathers with thumb and forefinger.

The bird is then shifted to the right hand, and the left hand used in picking the soft feathers from the breast. If the sticking has been done properly the feathers will all come out easily. The bird is again held in the left hand while the feathers are quickly stripped except the upper 3 inches on the neck, the feathers on the outer joints of the wings and a narrow ring around the hocks.

Shaping gives chickens a compact, plump appearance, and the returns received are greater than from those shipped rough and unprepared. The shaper is made by nailing two  $\frac{7}{8}$ -inch boards together at right angles, so as to form a trough of 6 inches, inside measurement and of desired length. As soon as the chicken is plucked, its legs are placed alongside its breast; then, with its breast downward, it is forced down into the angle of the shaper, covered with paper and a brick put on top to shape it, also one against its side to hold it in position. It is allowed to remain thus for at least six hours. After being thoroughly cooled and its skin being thoroughly dried, the chicken should be packed.

## CHAPTER XIII

### **Health and Sanitation**

It is the right of every creature to be healthy. Health is natural under normal conditions. Unless health is maintained, it will be impossible to succeed in poultry raising. It should, therefore, be the object of every poultry raiser to keep his fowls in vigorous condition so that they may thrive and produce the marketable products sought. Probably the majority of failures in poultry keeping is due to neglect or disobedience of those natural laws upon which normal conditions of health depend. It is a thousand times more important to understand and enforce these laws upon which health depends, than it is to be posted on poultry diseases.

The truth of this statement is evidenced by the fact that the most successful poultrymen rarely have cases of disease in their establishments. When diseases do appear, they immediately hunt until they find the cause rather than dope the bird or birds and allow the bad practice or neglect to continue. Fowls may be considered to be in health when they have clear, bright red combs, are quick and active in their movements, have good appetites and when the organs of the body act in a normal way.

From what has been said in previous pages as to management in breeding, feeding, housing, etc., it may be seen that diseases may result from bad methods of breeding, of feeding, of ventilation; from impure food, impure air, impure water; from

filth and from neglect of the comfort of fowls, especially with respect to the dust bath and the roosting quarters. Lack of exercise is also productive of disorders. Lack of grit and shell-forming material likewise give rise to various troubles. All of these and other neglects and bad practices are easily within the control of the poultryman. The situation of the poultry house and yards (see chapter on Location) may result unfavorably upon the health of the flock; so may the lack of sunshine and of drainage. Overcrowding is likely to pro-

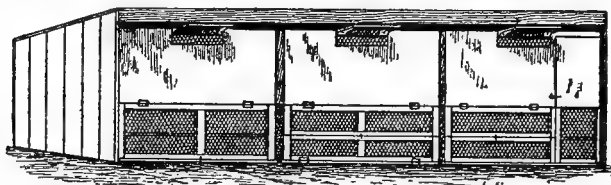

SHED FOR COLONY HOUSE

Protection adds greatly to the life of colony houses. If desired these houses may be used for autumn and winter quarters. Note three styles of front.

duce unfavorable results; fowls should not be kept closely confined in large numbers or in crowded quarters.

It is best to allow 10 to 15 square feet, or even more, for each adult bird in confinement. Where there is partial freedom, the area of the house may be reduced a third or a half from the above figures. The yard should be from 75 to 150 feet square for each fowl. The larger area will not be too much where grass is expected to grow in the run. All poultrymen agree that it is best to avoid draughts in the poultry house, at least draughts which strike the birds, especially during roosting time. The dif-

fusion system and the open front and fresh air houses obviate this defect.

## PENALTIES FOR UNCLEANNESS

At no time of the year are fowls so likely to be neglected as during the hot summer months when the farmer is making least out of them and sees smallest prospect of returns. No matter how well they may have been managed the previous winter and spring, interest in them is likely to lag when they lessen their laying. Neglect is most commonly evidenced in careless feeding and watering and in allowing the poultry houses and yards to become

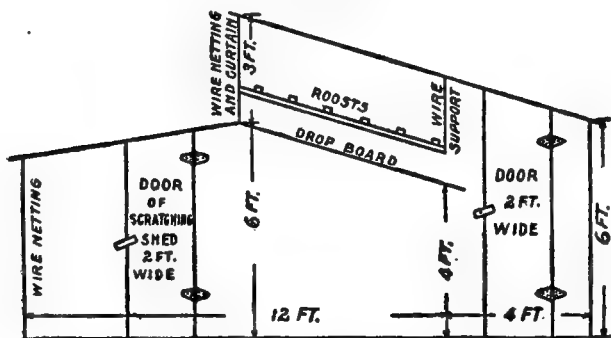

COMBINED SCRATCHING SHED AND HOUSE

Fresh-air house. Fowls have all floor space (16x12 feet), except 4-foot alley behind roosts. Curtain at peak for use when desired. About 600 feet lumber, four rolls paper, and half roll netting, four hinges, needed for 50 or 60 fowls. Cost of material about \$25.

unclean. If the birds have free range the careless feeding may produce no apparent serious effects; but this kind of luck seldom follows neglect of sanitary conditions.

More than 75 per cent of the ailments with which poultry are troubled are due to unsanitary conditions of the premises. And the foundation of a large proportion of this is laid during the hot months when the fowls should be in most vigorous health and be preparing for the work of the winter when eggs are high. Chicks cannot thrive in a small, tight, sun-heated coop, especially when their droppings are allowed to accumulate and the coop is kept in the same place from week to week.

Disinfectants, such as carbolic acid or a commercial article, may be used after the premises has been made clean, not before. They are not remedies for the results of neglect, nor do they make it possible for a man to keep filthy quarters and still make poultry pay. The man who thinks to avert the penalty due to carelessness by using disinfectants, lice powders or other so-called remedies, is penny wise and pound foolish, for he must sooner or later pay the penalty.

### DISINFECTION

Many people believe in using disinfectants freely. There is no objection to this, but there is a better system; namely, the maintenance of cleanliness which precludes the necessity for disinfection. Sometimes, however, maladies may be introduced unsuspectingly and the quarters become foul, in spite of ordinary precautions. The whole premises should be made scrupulously clean before any disinfection is started; then the disinfection should be exceedingly thorough and preferably repeated two or three times in the case of serious trouble.

Fowls that die from any disease considered contagious should be destroyed, preferably by fire, or

be buried so deeply that dogs and other animals will not dig them up. The danger of infection increases with the length of time that fowls are kept, especially in confinement, on the premises. For this reason, measures which make for cleanliness cannot be emphasized too strongly. Among the best disinfectants are hot whitewash made of quicklime. This wash should be used at least twice a year; once each quarter is better. To increase its disinfecting power two to four ounces of crude carbolic acid may be added to each gallon of the mixture. Kerosene oil and crude petroleum are often applied to the roosts, but these are not in as great favor as the lime wash.

Wherever possible, the yards should be dug or plowed in order to bury the droppings. If it is possible they should be planted to quick-growing crops so as to sweeten the land and also supply some green feed. Wherever possible, also, the flocks should be moved to new quarters every two or three years, so as to get the benefit of fresh ground. Preferably none but young birds should be moved to the new quarters. This will prevent contamination by old birds which may have been affected in the old yards.

## REMEDIES VS. PREVENTIVES

The adoption of remedies rather than the elimination of bad practices may be considered the entering wedge of failure for any poultryman, because it means the constantly increasing reliance upon a futile agent. The poultryman who adopts such practice is sure to neglect the conditions which make for health, because he is deluded with

the idea that he can cure his fowls by fussing and drugging. The result invariably is a larger and larger number of cases to treat, and a smaller and smaller balance in the ledger.

For this reason special emphasis is laid throughout this volume, and more particularly in this chapter, upon conditions which make for health. Only

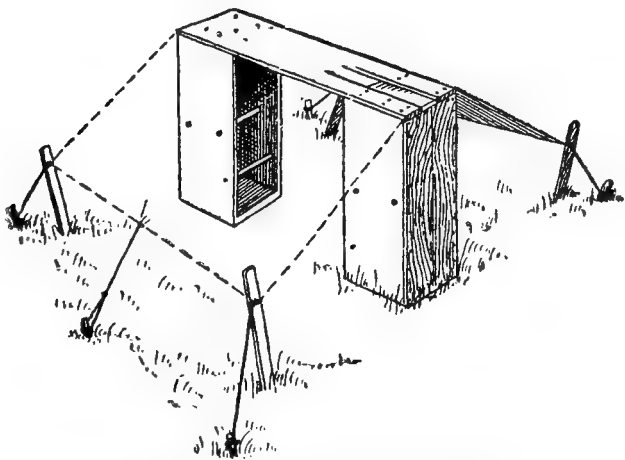

CANVAS-COVERED PULLET SHELTER

Two shoe boxes nailed together and provided with two roosts each. Canvas makes shade for sunny days.

sufficient hints are given to enable the poultryman to identify some of the common ailments and to ferret out through this identification the bad practice that has produced the trouble. In a general way, it may be said that sick fowls should be removed from the balance of the flock and nursed rather than drugged, but whether it will pay in the long run to do even this will depend upon the value



placed upon the individual fowl or fowls. It is much better, as a rule, to kill a few fowls and thus save the time and worry of nursing and also the possible risk to the balance of the flock, than to coddle and waste time with them.

The more rigidly the poultryman observes common sense rules of cleanliness, both in feed and quarters where the fowls are kept, the less will be his losses. These facts are well emphasized in the larger and more important poultry yards and stock farms all over the country. In such places where sanitation and pure food and drink are insisted upon, sickness is of very rare occurrence, and can nearly always be traced to carelessness in some respect. In every case it is essential to remove the cause before the effect, disease, can be destroyed. There is no use, therefore, in doping birds or animals with drugs so long as the external cause of their discomfort remains.

## IDENTIFYING DISEASES

When fowls are discovered to be ailing, the poultryman may be able to identify the trouble and thus trace the difficulty back to its cause, which, it is needless to say, should be eliminated. Let it be emphasized again that disease is due, as a rule, to something within the control of the poultryman and that it is folly to attempt removing anything without first rectifying the management or other factor at fault.

Sneezing, with watering of the eyes and nostrils, and with puffing of the face are indicative of a simple cold.

Fowls in well-ventilated houses, especially open

front and fresh-air houses, are not subject to colds.

Rattling in the throat with other symptoms of cold indicates bronchitis, due to the same causes as colds.

Ill-smelling discharges from the nostrils indicate roup. (See special discussion.)

Looseness of the bowels with smearing of feathers around the vent indicates diarrhea. (See special discussion.)

Droppings, greenish, becoming white and frothy, are characteristic of cholera; but when greenish yellow, are often a supplementary symptom of roup. (See discussion of cholera.)

Little lumps beneath the skin on the face often occur in roup.

Listlessness without other symptoms of disease usually indicates indigestion. This is caused by overfeeding and can be corrected by rectifying the diet, especially by feeding green stuff more liberally. Increased exercise is helpful.

Lameness may be caused by an accident. Accident may result in bumble foot, which is an abscess on the sole. It may be prevented by providing a runway to the roosts or making the roosts low.

Twisting the neck and head may indicate a giddiness or cramps.

Sudden death may be due to heart failure or apoplexy, but frequently it results from allowing some other disease to go unchecked.

Inability to eat food may be due to an obstruction between the crop and the gizzard or in the crop itself. Usually gentle kneading of the crop will permit the contents to be removed from the mouth or will remove the obstruction. Sometimes the crop may be opened by a short cut close to the

top and then sewed up again. Care must be taken not to sew the skin of the crop to the outside skin.

Hardened droppings indicate constipation, due to lack of green feed and of exercise, or in young chicks to binding feed such as boiled milk. Ample green feed and exercise are the best correctives.

Bareness of head of feathers, due to feather pulling and eating. (See special discussion.)

Gaping of little chicks, as if obstructions were in their throats, is due to small Y-shaped worms in the windpipe. Characteristic of flocks kept on the same soil from year to year. Give flocks of little chicks new ground annually, or at least not less often than once in three years.

Weakness of the legs indicates a lack of bone-forming ingredients in the feed. Reduce the proportion of carbohydrates and fat and increase the proportion of animal food, especially bone meal. Alfalfa and clover also help. Plenty of grit should be supplied.

## CHOLERA

No form of medical treatment has proved satisfactory, though many preparations have been recommended for the eradication of fowl cholera. No confidence can, therefore, be placed in internal medication. The proper way to fight cholera is by carrying out the strictest sanitary methods. Affected birds must be promptly isolated at least ten feet away from the flock. Dogs and other animals must be fenced out of the poultry yards if possible, and birds exhibited at poultry shows and elsewhere, as well as fowls brought from other places, should be kept separate for at least ten days.

so as not to spread the disease if possibly they have it. Attendants should also be similarly careful. Constant disinfection should continue until all signs of trouble are passed. A solution of one pound carbolic acid in 25 pounds, or 12 quarts, of water should be used everywhere in the sheds and poultry houses, and every part should be thus disinfected.

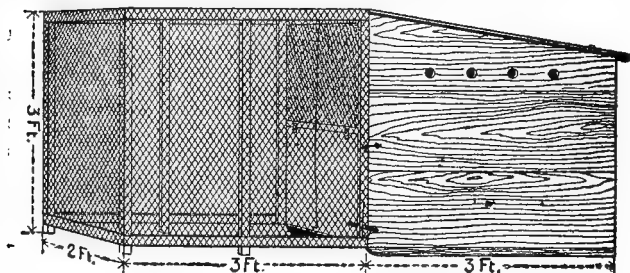

COOP WITH DETACHABLE RUN

Upper part of coop with canvas or wire netting front. Useful at first for young chicks; later as roosting quarters for cockerels and pullets.

## DIARRHEA

In every case what is called the white diarrhea in young chickens can be traced to mismanagement of some kind, either in the parent stock, the incubator, or chicks themselves after being hatched. The poultryman is generally not aware of the trouble being with his methods or with those of the men from whom he purchased the eggs, and is, therefore, likely to search for some remedy to cure the cases under his notice, when the whole matter lies in prevention.

It is the experience of practical poultrymen that remedies are unavailing, but that prevention is

satisfactory. One man who has incubated more than 30,000 eggs during the last few years has reduced his losses from white diarrhea to less than 1 per cent; in fact, during the last two years the trouble has been almost unknown in his yards.

Foremost among preventive measures is the selection of healthy, mature stock, which has not been forced to produce eggs for market prior to the use of eggs for hatching purposes. These birds should be kept in strictest cleanliness, with abundant fresh air, and an opportunity to exercise, preferably on free range. Food and water supplied should be such as the poultryman himself would be willing to eat or drink.

After the chicks are hatched the trouble may arise from improper management, either in feeding or brooding. The chicks should not be disturbed for at least 48 hours after hatching, nor should they be fed during this time. The yolk has been surrounded and is sufficient food to keep them going for several days. In fact, some poultrymen say that chicks will not starve if left without food for ten days. However, three days is recognized by men who ship day-old chicks for considerable distances. One of the very worst practices is to feed grit to chicks just out of the shell, as it is sure to irritate their tender intestinal membranes. Most important during these early days is water. This should always be pure and in abundance.

### FEATHER PULLING

Feather pulling, a so-called bad habit, is frequently observed in poultry yards during the late winter and early spring. Many people believe it to

be due to idleness in the flock, and they recommend exercise as the cure. There is a good deal in this, and flocks have been helped by being obliged to scratch in straw or leaves for the greater part of their grain food. It is believed, however, that the cause is not so much lack of exercise as lack of salt in their feed. Idle fowls will pull the feathers from one another's necks and get a little flavor of the salt in the soft part of the base of the feather. This taste prompts continued pulling, and often the fowls' necks are bare almost their full length. The remedy is to give abundant opportunity to exercise and feed a small quantity of salt in the wet mash, just enough to season the mixture. The habit is rarely observed when fowls have free range. At least, it is far less common among them than among those shut up in city yards.

## ROUP

The fundamental cause of roup can always be traced to filth of some kind; it may be no fault of the owner of the poultry, since the birds may eat putrid food or drink foul water while out on range, when visiting a neighbor's premises, or when exhibited at some poultry show; but usually the trouble lies in the home poultry quarters, especially if the birds have not free range. The source of infection may be in the water, the feed dishes, the yard or other places where the fowls are confined. For this reason it is imperative that the premises and vessels be thoroughly cleaned as soon as any trouble is discovered. After being made pure, the whole place may be sprayed with a 5 per cent solution of carbolic acid in water, care being taken

to fill every crack, as well as the whole surface of walls, ground and floor.

The yards should be spaded up or plowed and planted to some crop, such as mustard, turnips, rape, clover, or, in fact, anything that is quick growing. If the yards are small, and the fowls would prevent the young plants from growing, one-half of the yard may be sown, and then covered with poultry netting held up from the ground about 6 inches by a framework of wood; the fowls can then pick out the leaves as these reach the wire, but will not be able to injure the roots of the plants.

As for the affected birds, it is doubtful if any remedy would pay to apply, unless the fowls are very valuable, and as long as they remain on the place the owner runs the risk of having still more fowls sick by coming in contact with them. How-

ever, whenever it is desired to save them they should at once be removed some distance from the healthy ones, fed a well-balanced ration, containing a small proportion of meat. None of the remedies recommended have been found satisfactory so long

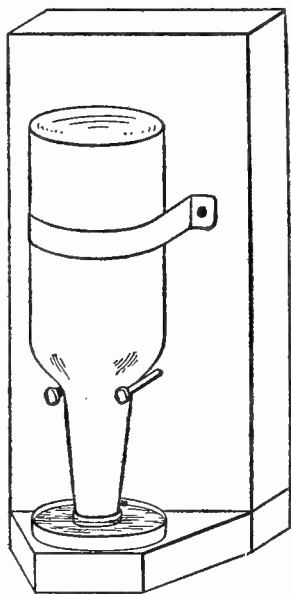

FOUNTAIN FOR CHICKS

Saucer or pan placed on shelf beneath suspended bottle.

as the cause of the trouble remains, but by evaporating oil of turpentine in a close room, so that the birds will be forced to breathe the vapor, is one of the most commonly applied remedies. Professional poultrymen have found that cleanliness, good ventilation, plenty of sunlight and exercise are positive preventives of roup.

## PESTS

As the warm spring weather approaches it is well to plan a little in anticipation of the annual campaign against the insect pests which infest poultry kind. Much of the ill luck complained of by beginners is traceable to lice. These get at the young chick almost as soon as it comes from the shell, and unless something is done to keep them down the chick will have a poor show.

## MITES

Mites do not live on the body of the fowl. They hide during the day in the crevices about the perches and adjacent parts. The perches should be movable, so they can be turned over or taken from the house. So also should be the nest boxes. The best nest receptacle is one of wire to be hung on a peg. It can be purchased of a dealer in poultry supplies. Boxes about 1 foot square can be used in the same way by nailing two cleats to the back. There should be a hole on each cleat by which to hang on nails driven in the wall of the house. The plainer a hen house is and the smoother the interior surface the better. There should be no permanent fixtures or partitions; then fewer hiding places for



the mites, and the house can be more easily rid of or protected from them.

Mites can be readily exterminated by brushing the roosting poles or exposed parts with a mixture of three parts kerosene and one part of crude carbolic acid. How often to do it can be determined by examination. It seems hardly practicable to get rid of them entirely, but they can be easily controlled in the manner stated. A good plan is to spread coal tar on the support on which the perch rests. It is well to place sitting hens in new boxes, as, if there should be any of the mites about, they will be apt to increase and drive the hens from the eggs before through hatching.

### LICE

Body lice, which lay their eggs and pass through their various stages of existence on the body of the fowl, are much harder to deal with. As a rule, active, healthy hens having free range or access to a good dust bath may be depended upon to keep themselves fairly well rid of body lice. It is recommended to dust them with insect powder, and sometimes this may become necessary, but it is a tedious and difficult job at best, and it is utterly impossible to kill all the vermin by one or two applications. It is well to examine the hens occasionally to see

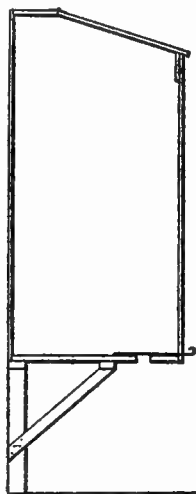

GRANARY

Shoe box; hinged top slide over grain vent.

how they are faring in regard to body lice. If present they will be found only on certain portions of the body, usually about the vent. Warm lard, to which has been added a few drops of kerosene, is useful.

To keep chickens free from lice it is sufficient to grease them two or three times with melted lard, according as they may seem to require it. They should be looked after closely and not be left until they begin to get mopy and stand around all drawn up in a heap. Some advocate using insect powders. These are all right if one can get good, fresh stock. Much of it that is sold at the stores is worthless. A dust bath made of equal parts of sifted hard coal ashes and land plaster is said by Prof. J. E. Rice to be the best thing tried at the New York State College poultry yards.

## WORMS

No remedy of any kind is so effective in destroying worms as to warrant its recommendation, because the only true way to deal with such conditions is to remove the cause. However, as a makeshift, the liberal use of cultivated or wild garlic in the mash is often adopted by poultrymen when their birds suffer from worms in any part of the digestive tract. Garlic must not, however, be looked upon as a remedy, because the fowls are left unprotected and liable to later attacks so long as the cause of the infestation exists. This cause is invariably filth of some kind. It may be that the birds have been confined on the same area for some time, and that the food thrown to them has become contaminated. This is the most common condition.

On the other hand fowls that have free range may pick up some filthy food, such as decayed meat, musty corn, etc., on which the eggs of worms may have been deposited. In either case the trouble is beyond control after the fowl has once eaten the food.

The first thing to do, where possible, is to give the birds new quarters, keeping them, however, in some intermediate place for a few weeks where they may be fed liberally, as already indicated, with garlic. After they seem to have recuperated and have become vigorous, they should be removed to the new quarters. Where this cannot be done, the whole premises should first be thoroughly cleaned; then a spray of carbolic acid and water at the rate of one to ten parts, should be made to reach every crevice and every surface of the entire poultry yard, buildings and runs. This spraying should be repeated at intervals of two days for at least two weeks, preferably in the early morning during bright, sunshiny weather, and during this time the litter in which the birds scratch, the dust baths, and the droppings should be removed daily and burned or deeply buried. If it is possible, the yard should be spaded up after the first spraying.

When the two weeks of treatment are concluded the supply of litter and dust should be changed once a week or oftener if a large number of fowls are kept in the yard, and every precaution should be taken to maintain the strictest cleanliness at all times.

## CHAPTER XIV

### **Water Fowl**

Not a few farmers seem to be prejudiced against water fowl, especially ducks. Geese are tolerated because they forage for themselves very largely and live on what they pick up from waste lands such as marshes and wet pastures. They are essentially grass-eating birds. From the time vegetation starts in spring till killed by frost in autumn, geese demand almost no attention. Goslings, after they are four weeks old, will also shift for themselves. Ducks, on the other hand, will not stand neglect so well, and they are more likely to wander and get lost or be killed by prowlers, such as foxes; then, too, the ducklings, if allowed on streams and ponds, are likely to be eaten by turtles and preying fish. Another objection is that ducks improperly managed often lay their eggs in the water. Unless they have desirable quarters and are given proper attention they are rather troublesome to look after. Besides this, they are very noisy, especially if disturbed at night. The careless farmer is most likely to be prejudiced against ducks for the above reasons, and also because half-fed ducks will overeat themselves when they do get a chance at food.

### **DUCKS**

As noted in Chapter II, it will not pay the farmer to go into duck raising on an extensive commercial scale unless he is situated within easy ac-

cess of a large city not well supplied with ducks. On the other hand, many farmers who have a good local market can make very nice profits out of ducks, even on a small scale. There are no special difficulties in the way; in fact, anyone can succeed with ducks. The brooding time is only half as long as that for chickens and the ducklings do not need nearly as much heat in the brooders. Where only a small number are to be raised, hens will do the hatching very successfully.

The duck has so many good qualities, it matures so early and furnishes such excellent meat and is so easily reared that every farmer should keep at least a few to supply his own table and make a little money from surplus ones. This applies especially where the older ducks can have access to a marsh, a pond or a stream, but where their wanderings may be restricted. Duck flesh is one of the greatest delicacies that can be raised on the farm.

A good deal of the trouble in raising ducks is due wholly to neglect, and to the unjust reputation of the duck as a gormandizer, a reputation based largely on irregularity of feeding. Half-starved ducks are not slow to take advantage of an opportunity to eat, so if grain or other food is accidentally left within reach they will surround as much of it as possible. On the other hand, if food is constantly before them, especially if they have a chance to forage, they will not, as a rule, eat more ravenously than other fowls. Usually under good man-

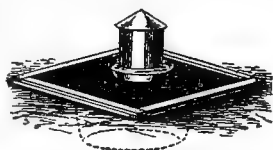

DUCK FOUNTAIN

Wire frame over gravel pit. Waste water drains off quickly.

agement, especially feeding, they attain their growth in four months, though under commercial conditions they are marketed at two or three months. For best prices August and September is the favorable season when one has access to summer resorts. During October and November later broods may also be disposed of at a profit, but for the ordinary farmer it is best not to keep ducks for a later market unless they have been hatched late in the season. If ducks can be hatched during March they may be disposed of at good prices during June or even earlier.

Ducks need no more water than chickens until they are three months old. Neither pond nor stream is necessary until the ducklings have their feathers. In fact, until the ducklings are well feathered, it is best that they be not allowed to get their down wet. For this reason their drinking fountains should be such that the little ducks cannot get more than their bills into the water. Thrifty ducks can easily be raised on a yard one-quarter of an acre in extent. When properly treated they should be no more troublesome than little chicks.

Hens, especially the more docile breeds, such as the Cochin and the Brahma, make excellent mothers. Another advantage of these breeds is that their large size enables them to cover several more eggs than Plymouth Rock and Wyandotte hens or hens of the lighter varieties. They will easily cover nine or ten eggs. If set very early, however, they should not be given quite so many unless their quarters are warm. No special remarks need be made concerning the hatching of eggs under hens. The period of incubation is 28 days. The eggs should be aired oftener and longer than hens' eggs

and not allowed to get as dry as hens' eggs while hatching. None but fresh eggs from healthy parent stock should be used. By fresh eggs is meant eggs not over ten days old. It is true that eggs, even three weeks old, have been set under hens, but these do not usually give as good results; the ducklings are likely to be weak. Preferably the hen should be taken from her nest at noon when the temperature of the air is warmest. A half hour off the nest will be sufficient for the hen to range, secure green food, grain, water and dust herself.

### CARE OF DUCKLINGS

As the ducklings hatch they should be put in a warm place, preferably near the kitchen stove, and kept warm just as little chicks are managed. When the hatch is over the ducklings may be put under the hen in a coop or in a brooder; preferably they should be kept confined for two or three days and then allowed to roam in a small yard as soon as the weather is warm. Many farmers who raise ducks on a small scale believe it absurd to allow a nice hen to run her legs off with a brood of ducklings. The ducklings are never still a minute. They care nothing for the mother except to use her at night as a hover.

If one has not enough ducklings to justify a brooder, a small box lined with old woolen or flannel goods will be found satisfactory. Heat may be supplied by a jug of hot water placed preferably above the heads of the ducklings. The little ducks may be fed at first with hard-boiled eggs, bread crumbs, clabber or other soft food. Mush and milk are also good, but preferably this food

should not be given before the second week. After they are two or three weeks old raw cornmeal, moistened with milk or water, may be fed, also scraps from the table. When scraps are fed the ducklings may be given some fresh animal feed, chopped cabbage, turnips, etc. Liver and lights are very good when finely mixed. Ducklings and older ducks do better on soft feed than on grain. In the soft feed should be some grit not too fine. Grit should also be within reach at all times.

### LOCALITIES FOR DUCK YARDS

Where one is situated on a tidewater stream or cove he should take advantage of the opportunity to raise ducks. There is in such a situation a constant succession of sea food which the ducks can secure with every ebb of the tide. All that is necessary is to supply a house or a pen on the shore, hoppers with ground grain and drinking fountains for the ducks to help themselves. When such are supplied the ducks will come home every night without trouble. Usually duck eggs are laid at night or in the early morning, and where the flock is properly managed there will be little danger of loss from laying in the water. If desired, the ducks may be kept shut up until, say, 10 o'clock, by which time practically all the eggs will have been laid.

Next to a tidewater situation comes a marsh, a stream or a pond, especially a marsh through which a stream flows. The ducks will pick up a large portion of their living, but in the absence of any of these advantages the farmer may easily keep ducks without trouble. He may make an artificial pond for the ducks to paddle in. This may be in any



convenient place, preferably not too near the house. It need not be expensive. Concrete may be used where the formation of the ground is not suitable for making a pond by means of a dam across the spring. The depth need not be more than 18 inches, and even that depth is not necessary so far as the water itself is concerned. Probably a foot will be ample depth for the water. The pond need be supplied only for the breeding ducks which mate in the water.

While it is possible for ducks to get along without water to swim in, yet they certainly do better when supplied with a place to paddle, and best where they have a chance to forage. Foraging for a duck is what scratching is for a hen. It supplies exercise and interest in life. If not given water range, ducks should have fresh water to drink always within easy reach. The duck fountain, placed upon a gravel pit, is one of the best arrangements, because it does not allow the ground around it to become muddy. Ducks splash a good deal of water around their drinking fountains and some means of drainage must be supplied or the place will become very foul in a short time. In a general way ducks can be profitably raised wherever hens can be.

### CLEANLINESS IS ESSENTIAL

at all times. The feeding and drinking vessels should be kept clean constantly, the floors should be littered with absorbent material such as shavings, waste hay or straw and this replaced before it becomes damp and foul. While it is a fact that ducks and geese also naturally spend time in the water, yet they like to have their sleeping and resting

places dry. The yards where ducks are kept should be scraped from time to time and fresh sand or earth thrown upon them. It is a good plan to have the yards plowed or spaded and sown to rye in the fall, or in the spring where the fowls have access during the summer, but not in the winter, to water range. Not only does this purify the soil, but it helps to supply feed.

No special remarks need be made concerning the quarters for ducks. Houses and yards may be practically the same as for hens, except that nests and roosts need not be supplied. Preference should always be given to well-drained soil, so that when rain falls the yards may not be sloppy and so that the droppings may be washed into the soil rather than over it or made into puddles. Shade is essential in the summer time. If there is no natural shade, artificial shade must be supplied. Ducks are very sensitive to the sun's heat. They will naturally take care of themselves in a marsh where there is shrubbery, but where shrubbery is absent they should have a simple shed or canvas cover under which they may take refuge.

At all times it is essential that ducks be treated kindly and quietly. Gentleness and quietness are absolutely necessary to the best development of the duck. As a rule, ducks are fearless until they are once frightened. When one is frightened fear rapidly spreads among the flock. If it is necessary to catch any duck it should always be caught by the body, never by the neck, and the person who does the catching should never be careless or rough in handling the ones caught. The same remark made concerning visitors and dogs with respect to hens applies even more forcibly to ducks. Never

should dogs or visitors be allowed in the breeding yard because the egg yield is sure to be reduced. After the breeding pens are once made up the groups should be maintained without change. Ducks quickly miss one of their companions, so if stock is to be kept for sale it should be separate from the breeding flocks.

Breeding ducks should be given free range or at least water in which to swim. They may be fed on almost any kind of mill feed. When they cannot have free range and thus pick up animal and vegetable life, they should be supplied with animal and vegetable food of some kind. Chopped clover, cabbage, kale, alfalfa; in fact, almost any vegetable, will do. This should be mixed with the wet mash to which bone meal or beef scrap and grit have been added. There is no reason why duck food should be cooked. Ducks do fully as well on raw feed. It is best that they do not have whole grain, because they cannot grind it as well as hens and turkeys do. At all times they must be supplied with water close to their feeding troughs. A reasonably full meal morning and evening is all that is necessary, especially where the ducks have free range. When ducks at range are to be fattened for the table, they should be removed from the general flock and fed only such food as will not give the flesh an unpleasant flavor. Fish and some of the vegetable matter that they might get in the marshes and ponds often impart unpleasant flavors to the flesh.

For breeding ducks Long Island growers use a mixture of one pailful each of wheat, oats, middlings, two pails of bran, four of cornmeal and two bushels of cut clover grass or other green thors-

oughly minced, mixed and wetted. The ducks are allowed to eat as much as they wish. It is necessary to feed some special formula like this only where it is impossible to give the ducks free range and an opportunity to balance up the food themselves.

## HATCHING IN INCUBATORS

Where duck eggs are hatched in incubators care must be given as to ventilation; since duck eggs are considerably larger than hen eggs they are more difficult to handle. The air space in the incubator is smaller proportionately for duck eggs than for hen eggs; hence, if one is going into the hatching of duck eggs, he should give preference to a machine with a larger air space than when hatching hen eggs. When such a machine is not used the ordinary incubator will do, provided it is run with greater care as to ventilation. Never should duck and chicken eggs, duck and turkey eggs, or duck and goose eggs be placed in the machine at the same time. Only one kind of egg should be used at a time. Duck eggs should be cooled longer than hen eggs. Some duck raisers believe in sprinkling the eggs with tepid water, especially during the last two weeks. Others think it advisable to dip the eggs in tepid water daily; still others do not practice either method. Much depends upon the way the machine is managed and the amount of moisture in the air of the egg chamber.

As a rule, ducklings break their shells 30 to 48 hours before emerging. If unable to get out without aid after the twenty-eighth day, they should

be given some help. In this respect they are less sensitive than chicks. For at least 24 hours the ducklings should be allowed to remain in the machine. When removed they should be taken to brooders in flocks not exceeding 50. Forty would be better. Management is practically the same as for chicks, excepting that the ducklings, at first, must be kept closer to the heat. Usually they will not need heat after six weeks old when hatched in the early spring; three weeks will be all that is necessary when the season becomes warm. After weaning the management of ducklings is the same no matter how raised.

For market the ducklings should be confined in smaller yards than for breeding purposes. They may be fed more liberally of fattening materials. When about six weeks of age they may be put in the fattening pens and fed a mixture of two-thirds of cornmeal with equal parts of bran, middlings and greens. To this 10 or 12 per cent of beef scrap may be added. Preferably ducklings intended for market should not be given water range. For breeders ducklings should be given their liberty as soon as weaned. Most commercial duck raisers allow the ducklings to run together in close quarters until they are old enough for marketing, then the best are sorted out, the home flock given wider liberty, a grass range or a pond, and encouraged to develop strength rather than fat.

### SELECTION OF BREEDERS

In sorting out ducks for breeders, females may be recognized from the males as early as six weeks old. When caught the ducks quack loudly. The

drakes, however, give a sort of a hissing quack or they may not be able to make a sound. Later on the characteristic curled tail feathers distinguish the drakes.

The usual method of killing ducks is the same as for chickens, except that after the veins and arteries are cut in the mouth, a sharp blow upon the head is given by striking against a post. This reduces undue movement and consequently soiling of the feathers from the blood. Since duck feathers command good prices they form an item of revenue not to be neglected. It is necessary to pick dry in order to get the best prices. As a rule, the sale of feathers will about pay for the cost of picking. Another advantage about dry picking is that dry-picked ducks usually sell for better prices than scalded ones.

The best time to kill ducks for market is at about ten weeks old or before a new crop of pin feathers appears. This reduces the amount of work considerably. Pin feathers may be removed more easily if wetted, since they may be caught between the thumb and a knife blade held in the hand. Usually the soft feathers from the wings are not removed, neither are the head and neck plucked. Ducks are rarely drawn or beheaded for market. After plucking the wings are brought close to the body and held in that position by strings or bandages. All the blood is removed by washing and the ducks are then placed in fresh water to cool down and later put in ice water. Generally it is thought best to place them breast downward so as to make the breasts look more attractive when exposed for sale.

## BREEDS OF DUCKS

Unquestionably the Pekin is the leading breed of ducks in America. It is a white-feathered bird, which may be easily kept in inclosures. The beaks are yellow. This breed is very large, uniform in size and rapid in development. At four months the ducklings should weigh 5 pounds each. In America they have no successful market rivals. This is because of their hardiness, quickness of growth and prolificacy of large, usually white, eggs. Standard weights are 8 pounds for the mature birds and 7 pounds for the duck. The carcass is very long and deep and contains a goodly proportion of meat both on the breast and behind.

The Aylesbury resembles the Pekin in general appearance and size, but the bodies are somewhat oval. The plumage is white and not so soft. The bill is flesh colored and the feet yellow, instead of reddish as in the Pekin. The Aylesbury stands with its body more horizontal than the Pekin. The breed is the leading market favorite in England. It is about as quick growing as the Pekin, but has not proved as satisfactory among American duck raisers. According to the standard of perfection, adult drakes weigh 9 pounds and ducks 8 pounds.

The Rouen ducks, which are given the same standard weights as the Aylesbury, look much like the common puddle ducks of the farm. When well bred, however, their colors are more pronounced and their size much larger. They are also better layers and quicker to mature. There is nothing to indicate that they are in any way inferior to Pekin or Aylesbury ducks for the table, but their color is against them for the general market. For home,

use they are fully as valuable as either of the other varieties mentioned.

The Muscovy, in two varieties, Colored and White, is a particularly unpleasant looking creature because of its featherless face covered with warty skin. This repulsive appearance is more than borne out by the viciousness of the males. The ducks are perhaps as pugnacious as the drakes when they have their broods. Adult drakes weigh 10 pounds; ducks 8. Prior to the importation of the Pekin, the Muscovy was popular among the commercial duck growers, but its poor-laying ability, its viciousness and its color all being against it, made it easy for the Pekin to replace it.

Besides these four principal ducks there are many others, but almost all are much lighter weight. Among them are the Cayuga, which is a hardy, early maturing, good layer, with greenish-black plumage and flight feathers in the female, sometimes more or less brown.

Indian Runner is another small variety introduced within recent years. The drakes rarely weigh more than 5 pounds and the ducks 4. They are usually light fawn colored, sometimes grayish. Their chief value is in their prolificacy. They have been called the Leghorns of the duck family. It is said they are more home loving than most other breeds.

Besides these varieties, there are several others, among them the Buff Orpington, a variety of recent origin and little known in this country. It hails from England. Gray and White Call Ducks, Black East Indian ducks and Crested White ducks are all little varieties raised particularly for ornament.



**GEESE**

While it is true that geese cannot be profitably raised in confinement (see page 39), it is a fact that on every farm a flock may be profitably reared

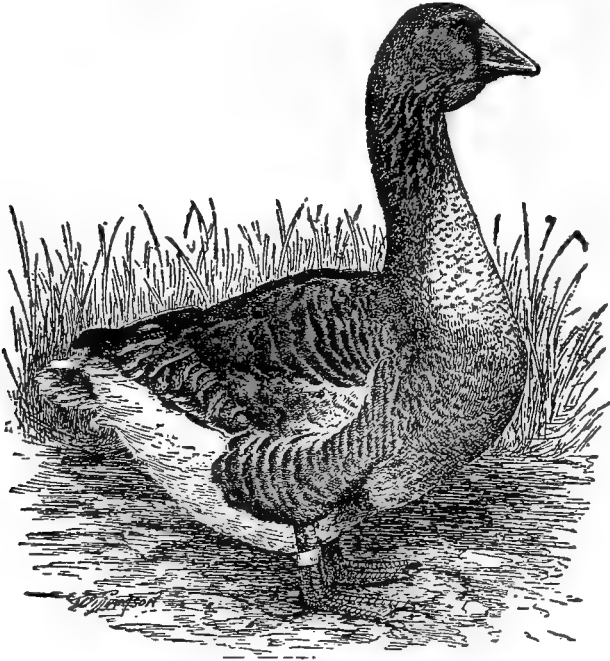

**CELEBRATED TOULOUSE GANDER**

For years this bird was first prize winner at Madison Square Garden Poultry Show. It was bred and owned by C. W. King of Seneca county, N. Y.

each year. Geese need not have access to a swimming pool, though, like all other water fowl, they enjoy water, and a pool is of great benefit

especially during the breeding season. They are very thirsty creatures and should always have abundant drinking water, especially during the warm weather. Geese are by far the cheapest and easiest of all domestic fowls to raise. They require but little shelter at any time, and if given plenty of pasture will gather the larger portion of their food from the fields.

An ideal pasture, such as is not desirable for animal grazing—a marsh, especially one with a stream running through, or bordering a pond—is admirable. Farmers are realizing the fact that it pays to utilize such waste land by raising geese upon it. Not only does such land not pay taxes ordinarily, but it is often a distinct disadvantage to the farm. When used for a goose pasture the loss can be wiped out completely and the geese sold from it made to yield a handsome profit. In fact, since the original breeding flock may be kept for many years, the only cost of keeping a flock of geese would be for the winter care and for the attention demanded by the goslings until they are able to take care of themselves. The goslings would pick up nearly all of their living from the waste land, and nearly all the money they would bring in the market or when sold for breeding purposes would be clear profit.

Many more geese could be raised in this country and still the demand would not fail. Each year geese are becoming more popular as table fowls. Very large, young geese, when well fattened, command a premium in the markets. In goose growing as well as in other lines of poultry production the value of good breeding stock cannot be overestimated. Good stock is as easily fed and cared

for as are inferior birds and give very much better results. Where farmers have been raising common geese at a profit there are excellent opportunities for them to raise pure-bred geese at a greater profit, because the pure breeds not only attain larger sizes and, as a rule, lay larger numbers of eggs, but the young are easier to rear and there is a fairly good demand for both eggs and birds for breeding. The prices for market geese, breeders and eggs are all excellent, so that there is every reason why pure-bred ones should replace inferior geese.

### GEESE NEED PASTURAGE

As already indicated, geese cannot be kept in confinement, because, like turkeys, they must have range, but, unlike turkeys, they are not rovers. They can be counted upon to come to their shelters regularly; they have a great love for home. For this reason they are easily kept on even small range and with almost no trouble as to fencing. Their chief food is vegetable matter which they prefer to pick in their wanderings. They also enjoy water, animal life, snails, slugs, worms, insects, etc., which they can secure. While it is true that they enjoy water and marshy places, they greatly prefer dry quarters in which to sleep. Since they are hardy, their shelters need not be as carefully constructed as those used for chickens. The principal thing is to secure dryness at all seasons and shelter from winds during cold weather. Geese do not make their quarters foul so quickly as ducks do, but it is just as essential that their shelters be kept clean. Straw and refuse hay, sawdust or shavings are equally useful in the sheds. What-

ever material is used should be removed and replaced before it becomes foul.

From what has been said, it may be correctly inferred that geese are kept in much smaller numbers than chickens or even turkeys, yet they reach the market in considerable quantities, especially in the western states. Along the Atlantic seaboard there are some farms where goose growing is made a specialty. Except for these farms there are very few places where geese are raised extensively. The great majority of market geese are raised in small numbers on ordinary farms, which, as a rule, still cling to flocks of inferior breeding. Though the market demand is by no means as great as for the other three great classes of poultry, yet this demand is not nearly met by the supply of stock. For this reason anyone situated near a good market and provided with a favorable site for goose growing should embrace his opportunity to supply this demand, but no desire for making money should tempt anyone not supplied with good grazing ground to begin goose growing, because while he may succeed in raising the geese he could not compete with farmers who have better facilities.

### PROFITS IN GOOSE GROWING

As to the amount of money that can be made from geese, much, of course, depends upon the market. Growers calculate that geese pay proportionately better than ducks, but since they cannot be grown in such large quantities nor by such machine methods the facilities sooner reach their profitable limit. The cost of producing young geese for market is estimated at less than 10 cents a pound, even when the goslings are fed heavily for

fattening during the last few weeks. This estimate of course does not apply to the special feeding methods practiced in Wisconsin. For the Jewish demand (see page 39), prices in the East usually start in the early season at 30 to 35 cents a pound; and sometimes fall as low as 15 cents during autumn. The season begins in June.

As a rule, good prices are realized during the holiday season. The sale of goslings at five or six weeks old to fatteners is rather common. Where there is not much demand for geese, profits are not as large as these figures might seem to indicate. It is believed that the production of mongrel geese (that is, crosses of the Brown China, African or Toulouse geese with wild ganders) is more profitable than ordinary goose growing. The goslings from these crosses, though sterile and therefore useless for breeding, are excellent for the market because of their large size—12 or 14 pounds—and because of a greater demand for them at advanced prices during the holiday season. It is not usual to make the reverse cross, that is, a domestic gander on wild geese, because the wild birds are much less prolific of eggs than the domestic geese. Generally the wild gander will mate with only one goose; domestic ganders will take two, three or even four geese.

When one plans to start goose raising he should buy his stock birds in the autumn, because that is the usual season for mating and also because the birds take some time to become accustomed to their new homes. If bought shortly before the breeding season the results are almost sure to be unsatisfactory. Either the birds will not mate or when they do the goose will not lay as early nor as well as she otherwise would, and the hatches may not be as

large, to say nothing of the delay likely to occur on account of the dislike for her new quarters.

It is highly desirable to buy old rather than young birds for breeding. No fear need be entertained that old geese will not do well. Much more may be expected of them than from old hens. Geese are considered profitable until ten or even 15 years of age, and ganders six or seven. For this reason a breeding flock need not be increased from year to year unless desired, and all the young progeny may be sold as soon as it reaches marketable size. Breeding stock may be purchased usually from \$3 to \$5 for each bird, or if eggs are desired from 25 to 50 cents each or \$2.50 to \$5 a dozen.

### SELECTING BREEDERS

Since geese are not usually very prolific breeders it is customary to remove the eggs as fast as laid for hatching under hens. This keeps the goose laying longer than she otherwise would. Incubators, as a rule, have not proved very satisfactory for hatching goose eggs. Hens may be given from four to seven eggs each, according to the season and their size. Testing for fertility should be made on the seventh or eighth day and infertile eggs removed. Incubation generally last 30 days, although sometimes longer.

Since many hens do not take kindly to goslings they must be closely watched when the goslings are hatching, otherwise they may kill their foster children. As soon as hatched, therefore, the goslings should be removed to a box lined with flannel and kept in a warm place. In a day or so they may be given to quiet hens that do not object to them.

Geese make good mothers, and when they show a decided disposition to set may be given a dozen to 15 eggs each. As a rule, they do not like to be moved from their regular places of laying and resent any interference while setting. It is a good plan to have several hens at the same time that the goose is to set and to give the goslings all to the goose.

The brood should be placed in warm quarters and care taken that the goslings do not run too much at first. They should be kept warm and quiet at least a week and not allowed to run around much nor to become excited. After they are four

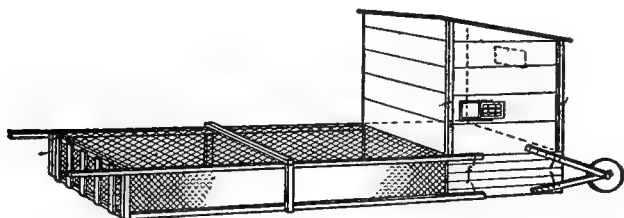

VEHICLE COOP

Packing case with attached run. Handles used to wheel coop about.

or five weeks old they will not need much attention, since the mother goose will take care of her brood. Goslings raised without mothers soon become self-dependent. It is important that the pens be upon rather short grass and moved at least once a day or as soon as the grass shows signs of becoming short. It is essential that shelter be provided from the sun and storm. Contrary to the popular belief, goslings should be kept from water,

except for drinking, until they have produced feathers.

### REARING THE GOSLINGS

Little goslings are very dainty eaters at first; their appetites will come in due time. During the first few days bread crumbs, soaked in milk or water and squeezed nearly dry are very good and are relished. This feed may be given three or four times a day with plenty of water to drink. The drinking fountain should be arranged so the goslings cannot wet more than their bills. During the second week a mash of equal parts ground oats, bran and cornmeal mixed with hot water may be fed cold five times a day and continued until the goslings are a month old. After the first few days they may have the freedom of a small pen where there is plenty of grass, and when two weeks old, their range may be extended. Clover and alfalfa are especially good.

When one month old the same mash may be used morning and evening with perhaps a meal at noon. Some breeders, however, prefer to feed the mash at morning and noon with cracked wheat at night. Until the goslings are fully feathered they should be kept out of the water and only those that are intended for breeding purposes should learn to swim. When two months old, feeding may be reduced to twice a day—soft feed in the morning and cracked corn or wheat, or a mixture of these two grains, at night. From this time forward the goslings may be allowed to roam at will. About three weeks before killing, those intended for market should be penned in a small space and fed a mixture of two parts cornmeal one part bran and one part beef scrap, with



corn at night, and oats and wheat at noon. Grit should always be placed where goslings can reach it.

The most important point next to feeding when rearing goslings for market is to keep the little birds tame and gentle. They should also be kept inclosed at night. When preparing for market, feed should be withheld for 12 hours before killing. After they are killed, an operation managed the same as for ducks, the carcasses should be plucked and singed. This singeing makes all the difference between an attractive and an unattractive looking carcass. Goslings of such breeds as Toulouse, Embden, African and some of the cross-bred geese weigh eight to 12 pounds when ten weeks to three months old. Individual specimens may weigh even more. It is generally more profitable to market them at that age than to hold them for a later market; prices are usually higher and there is less likelihood of running up the cost of feed. It is considered best, however, to hold mongrel geese for the Thanksgiving and Christmas markets, because of the higher prices they command. The season for geese begins in early June and continues until March of the following year.

One of the important sources of income from geese is the feathers. These, when properly managed, often sell for 50 cents or more a pound. Many goose raisers still practice the barbarous custom of plucking live geese. Whether this is a profitable practice or not is not the question. It is cruel, especially if plucking is resorted to frequently. This practice is probably responsible for the low prices often paid for certain classes of geese and for the poor condition that many geese are in when they reach the market. It is one thing for a goose

to molt naturally, but quite another to have the feathers pulled out every six weeks during the warm weather to force a new growth of feathers. Feather pulling is especially bad for geese used for breeding. Geese which have to grow extra crops of feathers cannot be expected to start laying as early, to lay as many eggs nor to have such good hatches as when Nature is allowed her own way. The practice is condemned by all the best breeders of geese.

### BREEDS OF GEESE

Probably the most popular breed of geese in America is the Toulouse. It is not only the largest but possibly the best adapted for general farm conditions, especially where the range is not ideal. It is thought to do better without a swimming area than other breeds. Its standard weights are 20 pounds for adult ganders and 18 for the geese. In general appearance it resembles the common farm goose more than the other breeds, but is much larger than these scrub geese. It is gray, though beneath and behind there are white areas in the plumage; the legs and the bill are orange. During their first year young geese lay 15 to 25 eggs. When older they may lay from 25 to 40. The breed is very quiet, but in spite of its wide popularity, is not ranked very high in the market.

The Embden is the chief rival of the Toulouse. While its standard weights are the same as for the Toulouse, a smaller proportion of the birds attain these weights. The plumage is white; legs and bill yellow. The Embden when well bred and properly

prepared not only makes the best-looking carcass but is superior to other breeds for marketing. One of the chief disadvantages in purchasing specimens is that there are many poor flocks in this country, poor not only in breeding, but poor in ability to lay. Intending purchasers should be careful in buying for these reasons.

Chinese geese are of two varieties—Brown and White. Their form and carriage is different from that of the two breeds already mentioned. They stand much more erect, have much longer and slenderer necks. In the Brown Chinese, at the base of the bill is a peculiar dark-colored knob, as will be seen in the half-tone picture of the breed. The standard weights are 14 pounds for the adult gander and 12 for the geese. The Brown variety is considered the most prolific of all geese. Under ordinary management the females will lay 40 to 50 eggs or even more, and these eggs are noted for their fertility. One of the chief disadvantages is that the carcasses are exceedingly hard to pluck and, when dressed, make the poorest appearance of all kinds of geese. In the White Chinese the plumage is white throughout, the bill and legs are orange colored and so is the knob at the base of the bill. While the geese lay as well as their brown cousins, their eggs are less fertile. White Chinese geese rival the Embden geese in the market. Their carcasses make a far better appearance than those of the Brown.

African geese are not nearly as common as other large varieties. Their color is gray, dark above, light below. On the back of the neck there is a dark stripe. Their weights are the same as for Embden and Toulouse. The bill is black and has

the same kind of black knob characteristic of the Brown Chinese variety. The legs are orange colored. As a rule, the geese lay better than the Embden, but not as well as the Toulouse, and the carcasses, especially of old birds, are hard to make look well for the market. The skin is dark, and this unfavorable color is not improved by the presence of down and pin feathers which are usually very hard to remove.

Besides the market varieties of geese described, there are several used for ornament, among them are the Egyptian. One of these varieties, the Wild or Canadian geese, however, is used for breeding mongrels, as already noticed. The Egyptian is purely ornamental.

## GOOSE AND DUCK FEATHERS

Generally speaking there is probably less waste of geese and duck feathers than of chicken and turkey, because the prices are considerably higher and the uses more numerous, and yet it is probable that many bring a lower price than they should because of the imperfect methods of sorting and curing. In the first place, the birds should be dry picked, so as to save the animal oils which give the feathers their "life." The reduction in grade because of scalding is not so great with geese and duck feathers as with turkey and chicken, provided proper care has been exercised and the birds immersed for only a very short time and the drying properly attended to. The feathers from the two kinds of birds should be kept separate, but otherwise the method of handling is simple.

A leading dealer writes as follows concerning the

handling of these products: Dry-picked goose and duck feathers should be placed on the floor and spread out for two or three days. The feathers from white birds should be kept by themselves. Special care should be taken to have the floors scrupulously clean, for white feathers especially, since the whiteness increases value. Each day until thoroughly dry, the feathers should be turned over. The quills and coarser feathers should never be included with the body feathers.

Burlap or cotton sacks are best for shipping the small feathers, which unless perfectly dry, are apt to become mildewed very rapidly and to command a reduced price. In the autumn, pure white goose feathers dry and in good condition are worth about 60 cents a pound. Gray goose and white duck 40 cents each, gray duck 32 cents. Scalded stock brings from 3 to 5 cents less a pound.

## CHAPTER XV

### **Turkeys**

As already indicated on page 40, the turkey readily fits in with farm work and yet not everyone can engage in turkey business because much depends upon surroundings. The laws of trespass do not permit animals and poultry to roam over the fields of one's neighbors, so unless the neighbors are willing to permit the wanderings of turkeys over their fields, this branch of poultry raising had better not be undertaken. It is essential that turkeys have range, and if one finds fields are not large enough to permit ample forage, turkey raising had best be abandoned as a leading branch of poultry raising. To be sure, a few turkeys can be grown on a small farm, even with limited range, but usually it is not safe to grow in restricted quarters more than will supply the demands of the home table.

So far as locality is concerned, turkeys can be raised anywhere. It is not safe, however, to attempt keeping them in damp places, nor heavy soils. Light soils, well drained, especially on uplands, suit them best. Where such conditions can be provided with abundant foraging ground, there is no reason why the turkey should not prove profitable. It does remarkably well in grain and stock sections, since the fowls can pick up much of the broken heads of grain left in the field and also secure abundant insect diet, particularly after the hay crop has been harvested. It must be remem-

bered, however, that turkeys are a side line; they have not been raised in commercial quantities like ducks or chickens.

One advantage of turkey raising is that expensive and extensive coops are not required. Probably the

majority of turkey raisers permit their turkeys to roost in trees no matter what the weather may be. This is not considered as desirable as formerly. There is no question that turkeys intended for market cannot make as good growth when exposed as when protected, at least somewhat, and it is just as

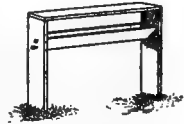

FEED TROUGH  
FOR TURKEYS  
AND ROOSTERS

unlikely that stock birds will do well when forced or permitted to roost in trees where, during a sleet storm they may freeze to the branches. On these accounts, shelter of some sort should be provided and the birds taught to roost under cover. The sheds need be only sufficient to keep out snow and rain and the severe wind. They may be somewhat after the order of the open-air house illustrated on page 60. These turkey sheds should, however, be more lofty than for chickens and the roosts should be several feet above the ground, preferably rather close to the roof. There is no reason why a turkey should not adopt more rational methods than it did in the forest and the fact that it can be taught to do so is distinctly in favor of the turkey raiser.

### TEMPORARY CONFINEMENT

During the laying season, many turkey raisers confine their flocks to comparatively small yards at least until their hens have decided upon a place

to lay. After the first two or three days of laying the hen turkey will rarely desert her nest, so that when the whole flock has begun to lay it may be allowed full freedom. As a modification of this plan, breeders keep the flock confined until about noon each day, until all the hens are laying. This practice saves the turkey raiser much time which would otherwise be needlessly wasted in watching turkeys to find out their nesting places and then walking daily from nest to nest to collect the eggs. A score of hens may be kept without difficulty in a yard 75 feet square. This inclosure need not be fenced very high. Few turkeys will attempt to fly over a woven wire fence 5 feet high.

The same practices in breeding discussed in Chapter VI apply to turkeys. It seems advisable, however, to lay special emphasis upon the selection of breeding turkeys because throughout the country the practice of breeding from inferior stock is the general rule. Most farmers select their best turkeys for the Thanksgiving market so as to get the high prices. This is well enough so far as the market is concerned, but if it leaves the slower growing stock for breeding, it is to be condemned. The best way in order to improve one's own flock is to select the breeding stock first of all, irrespective of any market considerations. None but the very choicest, quickest growing, best birds in every respect should be selected from each year's young flock to replace the old ones that have survived their usefulness. In this way, one can be continually improving, especially in size, precocity of development and stamina. Too much emphasis cannot be laid upon this fact. For best results turkey hens should be two years old and



cocks three years old or more. They will prove useful for eight or ten years or even longer. The customary size of a flock is ten to 12 hens to one tom, though often as many as 18 or even 20 hens are used.

## THE LAYING SEASON

As a rule, turkey hens begin to lay in the latter part of March or early April. Both season and latitude vary this considerably. For best results it is desirable that they be encouraged to lay in places convenient for the poultryman. Boxes, barrels, coops, etc., may be placed where desired or hay, straw, shavings, or other convenient material left in piles partially concealed by bushes. If the hens find such places ready, they will usually choose them in preference to wandering away, but if they do show a tendency to wander they should be confined as already noticed. During the breeding season grain should be fed in fairly liberal quantity. Corn, wheat and oats are all good, provided the fowls have free range. Many turkey raisers soak the grain for a day or more before feeding, others feed mash in the morning and grain at night. If turkeys are confined, great care should be exercised to supply not only plenty of grain and grit but animal feed, cut clover, alfalfa or other green feed and ample fresh water.

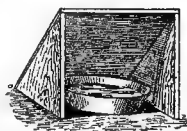

SHELTERED  
WATER

Turkey hens, especially young ones, rarely lay more than a dozen eggs before becoming broody. They may then be broken and made to lay a second

clutch of eggs. Older hens seldom lay more than a dozen and a half for their first litter and not quite so many in the second of the season. As an average, 20 eggs is probably the usual average of a hen turkey, though specially good hens may lay 30 or even 40. The eggs should be collected daily and stored in a cool place until they can be set. Eggs from specially productive and otherwise desirable hens should be marked and set separately, so their progeny can be marked when hatched and thus given preference when selection for breeding takes place the following autumn. It is a safe precaution to put a few hen's eggs in the turkey nests to keep the turkeys contented when laying.

## HATCHING

It is customary to set the early turkey eggs under chicken hens. While these hens make good sitters, even for the 28 days that turkey eggs require to be hatched, yet they are not as desirable mothers as turkey hens. They are more or less restless and less effective protectors against birds of prey, rats, etc.; they wean the little turkeys too soon and are harsher in their treatment of little turkeys, especially those that do not belong to their own flocks; they do not forage as well as turkey hens and the little ones, therefore, do not get as much insect food as they would with their natural mothers. Perhaps worst of all they are more likely to be troubled with lice. During the first few days while the little turkeys should be mothered a great deal, the chicken hen is likely to keep them roaming more than they can stand. She can be pre-

vented from doing this, however, by keeping her cooped or tied up. On the other hand, the chicken hen is more easily handled and thus is more likely to encourage tameness in her flock. She is far more certain to mother her brood in her coop than the turkey hen is. The turkey hen has to be carefully taught to bring her brood to the brooding quarters at night.

Because of objections to the chicken hen the practice is common of setting several hens at the same time that a turkey hen is set, so that the little ones may be given to the turkey either as soon as hatched or when the chicken hen weans her brood. There is no special objection to this latter practice, because turkey hens are not so averse to taking alien broods as are chicken hens, especially if the broods are brought together during the night.

No special directions need be given as to setting hens on turkey eggs; the practice is the same as for hen's eggs. Usually ordinary hens will cover eight to ten eggs; large ones perhaps two or three more. It is generally necessary to let turkey hens sit where they wish. They choose their own nests and object to being moved. This applies with special force to turkey hens that are more or less wild. Turkey hens may be moved in much the same way that chicken hens usually are, viz., at night, supplied with nest eggs for a day or so and when found satisfied given the regular clutch. Small turkey hens will cover 13 to 15 eggs; large ones perhaps 18 or 20.

It is usual for turkey eggs to be fertile. On this account it is not essential to test them, as chicken eggs are tested. Ordinarily, the only test is made about the twenty-sixth day. Then the eggs are placed

in warm water and the dead ones removed. Live ones can be recognized from the fact that they move in the water. Hatching usually commences on the twenty-eighth day, though it may last or even not start until the thirtieth day. It is just as important to remove the hatchlings as little chicks. They should be placed in a box lined with flannel or woolen goods and kept in a warm room.

### REARING

During the first day or two the turkeys do not need any food. The mother hen must, however, be fed liberally. It is a decided advantage to place the coop over the nest if possible so the turkey will feel at home and contented. Where this is not possible the brood and mother should be moved to desirable quarters; a coop with a board bottom should be given preference. After the first three days when the young ones are beginning to run around a small yard should be provided. A convenient yard may be made of three boards 14 inches wide set up on edge in the form of a triangle with a coop in one corner and the mother turkey allowed her freedom. She will not go far from her brood. The little ones may be kept in this kind of inclosure until they are large enough to jump up and make their escape.

As with chicks, the coops should be moved from place to place frequently. A space inclosing about 100 square feet will be ample for the ordinary sized brood. Where the coop cannot be placed upon short grass, ample green feed should be supplied daily. It is also important to give plenty of grit and charcoal and especially necessary to fight lice

from the very start; in fact the fight should begin when the hen or hen turkey is set and as much headway made as possible in the way of prevention—before the shells are pipped. It is not safe to use kerosene on turkeys. Insect powder is satisfactory and harmless.

Pens should always be situated on dry soil, preferably where there is no danger of flooding during a rain. Nothing is so important as to maintain cleanliness at all times, unless it is to keep the little ones dry until after

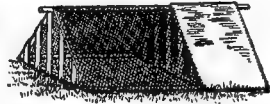

**PORTABLE CHICKEN COOP**

Ends of ridge pole extend for handles. Slats, wire netting and roofing paper tacked to frame of light wood. Size 6x3 feet, yard 4x3 feet.

their heads have become red. Up to this time of "shooting the red" is considered a trying period for poults. After they have passed it they are much more hardy. During the development of the red itself more animal feed than usual should be given. From the time that the little ones begin to wander they should be taught and encouraged to come to roosting quarters in the evening. This may be managed very easily by accustoming them to an evening feed of grain. About the time that they shoot the red or a little after they usually begin to roost. Roosts should be placed 3 or 4 feet above the ground where there is plenty of protection, preferably in regular turkey quarters.

Various breeders have their preference as to turkey feeds. Perhaps the most general favorite for turkeys a day old is hard-boiled eggs and stale bread soaked in milk but squeezed comparatively dry. Generally the egg is fed a day or two before the bread. When a week or ten days old clabber

is often used. When about two weeks old many breeders give a mixture of equal parts of milk and cornmeal, middlings or some other meal. This is allowed to swell for several hours before being fed so as to prevent any possible danger of swelling after being eaten. About this time cracked corn and wheat are often given in the evening.

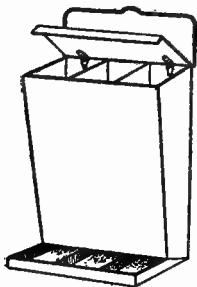

GRIT, SHELL AND  
CHARCOAL  
HOPPER

Three times a day seems to be enough to feed little turkeys until they are well grown, especially if allowed more or less range and given an opportunity to pick grass, insects, etc. In fact, it is almost essential that they have something to pick at all the time. For this reason a grass yard should be given the preference to all other quarters. Milk may be given instead of drinking water if

desired, but it seems best to have ample pure water before the brood at all times, whether milk is fed or not. It is also essential to have grit. Some turkey raisers, especially those who do not have grass runs, consider it necessary to feed every two or three hours until the birds are ten days or two weeks old. No more should be fed at a time than the poults will eat without waste.

Many poultrymen feed johnnycake made of cheap flour, preferably of the whole grain and cornmeal mixed with milk and infertile eggs from the incubator, but without soda or baking powder. The ingredients may be of almost any ratio, but preferably about equal parts. After mixing to a rather soft batter, the cake is thoroughly baked and allowed

to become rather dry. It is then allowed to become stale before being crumbled for feeding. This practice eliminates the danger of swelling after being eaten. The swelling takes place in the oven.

Gradually after the first week small seeds, such as millet, cracked wheat and corn may be added to the daily ration according as the poults grow in size. A good mixture of grains for fattening consists of one bushel each of whole and cracked corn and one-half bushel each of kafir corn and oats. While this is being fed the fowls should be somewhat confined. Feeding of the fattening ration begins about the first of November. Some raisers prefer to feed whole corn exclusively three times a day and some object to confining the birds at all. When fed liberally on corn they do not forage as much as usual.

### PROFITS IN TURKEY RAISING

The profits in turkey raising for the market range, as a rule, between 75 cents and \$1 a head. The opportunities for the sale of breeding stock are much less than with chickens, so there is not much money to be made in this direction, though it is a decided advantage to keep good stock. From about the last week in November until New Year's is the best season for marketing turkeys. Rarely are turkeys kept over this period unless they happen to be late-hatched ones. These may be developed for the January, February or even March markets. During these months such fowls will command good prices, but, as a rule, it will not pay to keep turkeys this late if they are ready for the holiday market. The advance in price would be more than offset by the cost of feed.

In a few cases there is a small demand for specially young turkeys, say three months old or perhaps a little younger, but it will not pay to cater to this market unless one knows beforehand that there is a definite demand. The only places there is such a demand is at a few of the fashionable summer resorts in the East. The greatest demand is for turkeys of medium size, ten to 15 pounds, for home tables. Such turkeys sell best about Thanksgiving time. Extra large birds are in smaller demand and at lower prices, as a rule. They are used mainly in restaurants and hotels.

### VARIETIES OF TURKEYS

There are six leading varieties of turkeys. Besides these there are also scrub turkeys which are altogether too common and are not nearly as desirable to keep as birds of good breeding. As a rule, they are not as robust, as large nor as prolific, nor do they make as good an appearance when dressed. One of the principal reasons for this is that the best birds have been sold annually for market instead of being kept for breeding.

About the best way to improve a farm flock of no special breeding is to purchase a well-bred tom in the autumn and mate him to a dozen or a score of the choicest hens, young and old, on the place. From the progeny select the very best young hens to take the place of the less desirable ones in the previous season's flock. All young males should be disposed of and preferably a new male introduced, one not related to the male purchased the first year, but of excellent breeding. By excellent breeding is meant a bird with good stamina, good weight and preferably two years or more old. If



two neighbors would agree on changing males every second year, only two males need be purchased and the danger of close inbreeding could be avoided, to the great benefit of both flocks.

Unquestionably the leading variety is the Bronze or Mammoth Bronze. This is also the largest and most profitable. The adult tom has a standard weight of 36 pounds and the hen 20 pounds. Much greater weights than these are often reached. Usually, however, these heavy weights are bred for sale to fanciers. One objection to the Bronze variety is that the hens are considered poorer layers than hens of other kinds.

The Narragansett is a close second to the Bronze in size and popularity. Its standard weights are 30 and 18 pounds for the tom and hen respectively. In general, their color is gray, mixed with black.

Black, Buff and Slate turkeys are uniformly colored as their names imply. They weigh 27 and 18 pounds respectively for cock and hen. Though fairly well distributed throughout the country they are by no means as popular as the Narragansett, the Bronze and White Holland.

The White Holland is the smallest variety of turkey. Its standard weights are 26 and 16 pounds for tom and hen respectively. Locally in many places they push the Bronze variety in popularity. They are reputed to be better layers and more home loving than some of the other breeds.

# Index

	Page		Page
Advertising .....	21, 22	Chinese Geese .....	261
African Geese .....	261	Cholera .....	229
Air, Bad .....	221	Cleanliness Essential .....	223
Alfalfa, Composition .....	118	Climate .....	46
American Class Discussed .....	103	Clover, Composition .....	118
Animal Feed .....	121	Cochin .....	110
Apoplexy .....	228	Cold .....	227
Appetite Indicates Vigor .....	97	Cold Storage .....	196
Arrangement of Pens .....	57	Colony System .....	53
Ash in Feeds .....	114	Colony vs. Permanent House .....	54
Associations, Co-operative .....	203	Comb, Color of .....	96
Atwood, Prof., Milk Experiments .....	132	Concrete Houses .....	56
Aylesbury Ducks .....	249	Confinement of Turkeys .....	265
Barley .....	118, 121	Conn. Egg Preservation .....	209
Baskets for Eggs .....	164	Constipation .....	229
Beef Scrap .....	113, 118, 123	Construction of Houses .....	55
Black Turkeys .....	275	Contagion .....	224
Blastoderm .....	160	Coops .....	70
Blood, Composition .....	118	Coops, Brood .....	73
Bone, Composition .....	118	Coops, Knock Down .....	73
Boxes for Eggs .....	163	Coops, Shipping .....	75
Brahma, Dark .....	110	Corn .....	118, 120
Brahma, Light .....	106	Corn, Egg Preservation .....	44
Brand, Composition .....	118	Courtesy .....	208
Breeders for Sale .....	36	Cramps .....	228
Breed, Importance of Good .....	9	Crop-bound .....	228
Breed, to Keep .....	102	Cropping Yards .....	225
Breeding, Bad .....	221	Crowding .....	92, 222
Breeding Ducks .....	247	Culling, Importance of .....	88
Breeding Geese .....	256	Cutters, Hay .....	71
Breeding, Live .....	82	Delaware Climate .....	46
Breeding, Mistakes in .....	87	Diarrhoea .....	230
Breeding Utility .....	81	Digging Yards .....	225
Breeds, Most in Demand .....	1	Disease, Identifying .....	227
Breeds of Ducks .....	249	Diseases Due to Faults .....	221
Brewer's Grains, Composition .....	118	Disinfectants .....	224
Broilers .....	27	Dominique .....	109
Bronze Turkeys .....	275	Dorking .....	110
Brooder, Management .....	177	Drainage .....	49
Broodiness .....	153, 178	Dressing .....	192
Brick Houses .....	56	Dropping Boards .....	67
Buff Turkeys .....	275	Drugging .....	226
Cabbage, Composition .....	118	Dryden .....	118, 126
Call Ducks .....	250	Duck Eggs, Market .....	15
Capons .....	33, 138	Duck, Feathers .....	262
Carbohydrates .....	114	Ducklings, Day Old .....	15
Carbolic Acid .....	225	Ducks .....	37, 238
Care in Spring .....	148	Dust Bath .....	222
Case Count .....	199	Egg Buying .....	199
Cayuga Ducks .....	250	Egg Composition .....	115
Cellar for Incubators .....	173	Egg Gathering .....	212
Charcoal .....	125	Egg Marketing, to Improve .....	201
Cheese, Composition .....	118	Egg Production Unbroken .....	147
Cheese, Making Cottage .....	122	Egg Structure .....	160
Chesapeake Climate .....	45	Egg Testing .....	162, 171
Chicks .....	24, 177, 182, 184, 188	Egg Yield and Gentleness .....	151
Chickens, Market .....	191	Egg Yield, Annual .....	142

	Page		Page
Eggs, Advertising.....	21	Grit Crushers .....	72
Eggs, Census Averages.....	7	Grit, Necessity for.....	124, 222
Eggs, Duck, Market.....	15	Guaranteeing Hatches.....	21
Eggs, Feeding for.....	146	Guineas .....	41
Eggs for Hatching.....	19	Hamburg Varieties.....	109
Eggs for Home.....	16	Hatchability Injured.....	93
Eggs for Market.....	17	Hatches, Guaranteed.....	21
Eggs, Hennerly.....	4	Hatching Ducks.....	246
Eggs in Demand.....	2	Hatching Turkeys.....	267
Eggs in Storage.....	196	Health .....	221
Eggs, Managing.....	4, 199	Heavy Feeding, Danger of.....	92
Eggs on Commission.....	3	Hens, as Layers.....	149
Eggs, Preservation of.....	209	Hens, Disposal of.....	29
Eggs, Shipping.....	163	Hens, for Turkey Eggs.....	268
Eggs, Storage.....	3	Hens, Home Loving.....	152
Eggs, Turkey.....	267	Hens, Turkey.....	267
Elford, on Fattening.....	216	Houdan .....	109
Ellis, Egg Methods.....	204	House, Curtain Front.....	154
Embden Geese.....	260	House, Knock Down.....	63
Exercise Essential.....	127, 222	House, Open Front.....	60
Failure, Causes of.....	80	Houses, Colony.....	71
Fat .....	114	Houses, Permanent.....	54
Fattening, Crate.....	216	Incubation .....	159
Feather Pulling.....	231	Incubation, Defective.....	93
Feathers .....	262	Incubation of Turkey Eggs.....	269
Feed Affects Color of Yolk.....	113	Incubator, Care of.....	172
Feed Affects Egg Quality.....	113	Incubator Record.....	168
Feed Affects Egg Yield.....	113	Incubator, Setting up.....	170
Feed, Composition.....	114	Incubator, Starting.....	170
Feed, How Often.....	180	Incubator, Storing.....	173
Feeding Chicks.....	178	Incubators, Classes of.....	165
Feeding for Eggs.....	146	Indian Runner Ducks.....	250
Feeding, Improper.....	221	Indigestion .....	228
Feeding in Transit.....	189	Infection .....	225
Feeds, Composition of.....	118	Insect Powder .....	235
Feeds for Chicks.....	179	Javas .....	109
Feeds for Fattening.....	218	Johnnycake for Turkeys.....	272
Feeds for Turkeys.....	270	Jordan, Quoted.....	90
Fertility .....	93, 160	Kale, Composition.....	118
Fish Affects Egg Flavor.....	113	Kansas Chick Experiments.....	179
Flock, Record.....	154	Kerosene.....	225, 235
Fountains .....	70	Killing .....	193, 219
Fowl, Kind to Keep.....	102	King's Toulouse Gander.....	251
Fowl, Type for Fattening.....	217	Lameness .....	228
Fowls, Farmers'.....	13	Lamson on Egg Preservation.....	209
Fowls, Fattening.....	13	Land, Detrimental.....	49
Fowls in Demand.....	14	Langshan .....	109
Freezing Poultry.....	195	Layers .....	35
Gapes.....	229	Layers, Autumn, Care of.....	151
Garlic.....	236	Layers, Management of.....	145
Gates.....	74	Layers, Selecting.....	143
Geese.....	39, 251	Leghorn Discussed.....	105
Geese, Breeds.....	260	Leghorns, Experiments with.....	77, 98
Geese, Toulouse.....	260	Lice .....	235
Gentleness Affects Egg Yield.....	151	Lice on Chicks.....	188
Giddiness .....	228	Linseed Meal Composition.....	118
Gluten Meal, Composition.....	118	Litter, Importance of.....	130
Goose, Feathers.....	262	Loss off.....	200
Goose Profits.....	254	Maine Experiments.....	142
Goslings, Day Old.....	15	Mammoth Bronze Turkeys.....	275
Goslings, Rearing.....	258	Management of Incubators.....	167
Gowell, Quoted.....	43	Mangel Composition.....	118
Grain, Ground or Not.....	128	Market Eggs.....	7
Grease .....	236	Market for Eggs.....	3
Griffin, J. W.....	58	Market Limits .....	12

	Page		Page
Market Stock .....	192	Record of 600 Hens .....	154
Marking Packages .....	190	Remedies .....	225
Mash, Dry or Wet .....	131	Rhode Island Red Discussed .....	108
Mediterranean Fowls .....	103	Rice, on Green Feed .....	124
Method, Value of Good .....	127	Rice, Quoted .....	95
Middlings, Composition .....	118	Roasters .....	28
Milk, Composition .....	118	Roasters, Soft .....	29
Milk, Discussed .....	122	Roosts .....	66
Milk, Value of Skim .....	132	Rouen Ducks .....	249
Minorca .....	110	Roup .....	228, 232
Mites .....	234	Salesmanship .....	207
Moisture in Incubators .....	166	Sales, Private .....	204
Molt, Feed During .....	146	Sanitation .....	221
Muscovy Ducks .....	250	Scalding .....	192
Narragansett Turkeys .....	275	Secrets, Poultry .....	43
Nests .....	68	Selection .....	79
Nests, One Board Trap .....	75	Shade Necessary .....	149
Nests, Requisites of Trap .....	99	Shaping .....	220
Nests, Trap .....	68	Shell .....	125
New Jersey Climate .....	45	Shell Necessary .....	222
N.Y. Experiment Sta., Quoted .....	90	Shipping to Market .....	190
Oats and Peas for Feed .....	124	Situation .....	47
Oats, Composition .....	118	Slate Turkeys .....	275
Oats, Discussed .....	121	Soil, Detrimental .....	49
Onions Affect Egg Flavor .....	113	Soil Factor .....	48
Ont., Fattening Experiments .....	216	Squabs .....	41
Oregon Trap Nest .....	75	Stewart, Prof., Experiments .....	132
Orpington .....	111	Stone Houses .....	56
Orpington Ducks .....	250	Summer Care .....	148
Packages, for Eggs .....	163	Sunflower, Composition .....	118
Packing .....	194	Surface, Quoted .....	142
Parents, Value of Vigorous .....	94	Systems .....	42
Pasture for Geese .....	253	Testing Eggs .....	162, 171
Pearl, Quoted .....	142	Toulouse Geese .....	260
Peas and Oats for Feed .....	124	Traps .....	73
Peas, Composition .....	118	Troughs, Feeding .....	69
Pekin Ducks .....	249	Turkey Profits .....	273
Pepper .....	125	Turkeys .....	40, 264
Pests .....	234	Turkeys, Day Old .....	15
Petroleum .....	225	Turkeys, Market .....	191
Phillips on Egg Marketing .....	199	Turkey Varieties .....	274
Picking .....	192	Variety to Keep .....	102
Plumping .....	194	Vegetable Feed .....	123
Plymouth Rock Discussed .....	104	Ventilation .....	56, 221
Plymouth Rock Experiments .....	98	Ventilation for Incubators .....	167
Polish Varieties .....	109	Vetch, Composition .....	118
Poultry Branches .....	15	Vigor Constitutional .....	89
Poultry Dressed .....	191	Vigor of Progeny .....	99
Poultry for Home .....	16	Virginia Climate .....	45
Poultry, Frozen .....	195	Vitality Impaired .....	91
Poultry Industry, Growth .....	6	Water, Impure .....	221
Poultry in Storage .....	196	Water Supply .....	51
Preservation Experiments .....	212	Wattles, Color of .....	96
Preventives .....	225	Weakness, Eliminating .....	89
Production, Annual .....	142	Weakness of Legs .....	229
Productiveness, Danger of .....	91	West Virginia Experiments .....	77, 132
Profit from 600 Hens .....	158	Wheat, Composition .....	118
Profit from Turkeys .....	273	Wheat, Discussed .....	119
Protein .....	114	White Holland Turkeys .....	275
Pullets as Layers .....	146	Whitewash .....	225
Range Advisable .....	149	White Wonder .....	109
Rape, Composition .....	118	Worms .....	236
Rations Recommended .....	126	Wyandottes, Discussed .....	107
Ratio Nutritive .....	118	Yield, Egg .....	142
Record Incubator .....	168	Yolk, Color Affected .....	113







