

UNIVERSITY OF TORONTO





# Cornell University Library

The original of this book is in  
the Cornell University Library.

There are no known copyright restrictions in  
the United States on the use of the text.

Cornell University Library

arV18394

A course of elementary practical physiol



3 1924 031 263 357

olin,anx









A COURSE  
OF  
ELEMENTARY  
PRACTICAL PHYSIOLOGY  
AND HISTOLOGY.



A COURSE  
OF  
ELEMENTARY  
PRACTICAL PHYSIOLOGY  
AND HISTOLOGY,

BY

*Michael*  
M. FOSTER, M.D., F.R.S.,

PROFESSOR OF PHYSIOLOGY IN THE UNIVERSITY OF CAMBRIDGE.

AND

*John Newport*  
J. N. LANGLEY, M.A., F.R.S.,

FELLOW OF TRINITY COLLEGE, CAMBRIDGE.

SIXTH EDITION.

London:  
MACMILLAN AND CO.  
AND NEW YORK.

1888

[The Right of Translation is reserved.]



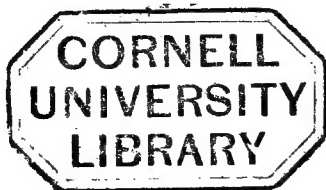

*First Edition, Crown 8vo., July 1876.*  
*Reprinted April 1877, December 1877, October 1880,*  
*November 1880, 1881, 1882, 1883.*  
*Revised and Enlarged Edition February 1884.*  
*Reprinted 1887, 1888.*

# CONTENTS.

	PAGE
LESSON I. Dissection of a Rabbit and of a Dog . . . . .	1—34
LESSON II. Structure of Blood . . . . .	35—43
LESSON III. Coagulation of Blood. Characters of Proteids . . . . .	44—51
LESSON IV. Hyaline Cartilage . . . . .	52—57
LESSON V. Connective Tissue . . . . .	58—67
LESSON VI. Modification of Connective Tissue and Hyaline Cartilage . . . . .	68—71
LESSON VII. Bone, Ossification, Teeth . . . . .	72—79
LESSON VIII. Structure of Contractile Tissues . . . . .	80—89
LESSON IX. Properties of Contractile Tissue . . . . .	90—104
LESSON X. Structure of Nervous Tissues . . . . .	105—115
LESSON XI. General Properties of Nervous Tissue. Automatic Actions . . . . .	116—123
LESSON XII. Structure and Properties of Blood-Vessels . . . . .	124—135
LESSON XIII. Structure and Action of the Heart . . . . .	136—146
LESSON XIV. Blood Pressure . . . . .	147—154

## CONTENTS.

	PAGE
LESSON XV. Salivary Glands and Pancreas. Saliva . . . . .	155—166
LESSON XVI. Stomach. Gastric Juice. Milk . . . . .	167—177
LESSON XVII. Intestine. Bile. Pancreatic Juice . . . . .	178—190
LESSON XVIII. The Lymphatic System . . . . .	191—203
LESSON XIX. Structure of Liver. Glycogen . . . . .	204—210
LESSON XX. The Structure of the Lung. The Me- chanics of Respiration . . . . .	211—218
LESSON XXI. The Colour of Blood. Respiration . . . . .	219—227
LESSON XXII. Structure of the Kidney . . . . .	228—236
LESSON XXIII. Urine . . . . .	237—245
LESSON XXIV. Skin and Touch . . . . .	246—256
LESSON XXV. Taste and Smell . . . . .	257—262
LESSON XXVI. The Eye . . . . .	263—274
LESSON XXVII. Vision . . . . .	275—290
LESSON XXVIII. The Ear . . . . .	291—300
LESSON XXIX. The Spinal Cord . . . . .	301—307
LESSON XXX. The Brain . . . . .	308—330
LESSON XXXI. Dissection of the Larynx . . . . .	331—335
LESSON XXXII. Tissues of Reproduction . . . . .	336—344
APPENDIX . . . . .	345—386
ADDITIONS TO APPENDIX . . . . .	387—403
INDEX . . . . .	404—412
ADDITIONS TO INDEX . . . . .	413



## LESSON I.

### DISSECTION OF A RABBIT AND OF A DOG.

In the following, the descriptions in large type apply more particularly to the rabbit, but the general directions for dissection serve also for the dog: some points in which the two animals differ, and some which are better seen in the dog, are printed in small type.

- A. 1. Make a median incision through the skin, down the whole length of the front of the body from the neck to the pubis, and reflect the skin as far as possible on both sides.

In dissecting a female rabbit note, just underneath the skin, the thin arborescent **mammary glands**, one to each mamma.

2. Observe the thin, pale, **abdominal muscles**. It is better to dissect out the individual muscles in the dog as below, but the dissection may be done on the rabbit.

In the dog observe

- a. The tendinous aponeuroses of the abdominal muscles forming in the middle line the *linea alba*.

- b. The *obliquus externus abdominis*, a thin muscle, with descending fibres; it arises from the ribs by separate bundles, from the back by a broad tendon and runs to the linea alba and to the pubis.
- c. The *recti abdominis*, one on either side of the middle line, covered by the tendon of the external oblique.

If *b* be carefully reflected, there will be seen underneath:

- d. The *internus obliquus abdominis*, with ascending fibres, it arises from the pubis and lumbar fascia and runs to the linea alba and lower ribs; and underneath this
- e. The *transversalis abdominis*, it arises from the lower ribs, the dorso-lumbar fascia and the pubis, and runs to the linea alba.

3. Lift up the abdominal wall and cut it through in the middle line from the sternum to the pubis, being careful to avoid puncturing the intestine. From the middle of this cut make transverse cuts nearly as far as the spinal column. Hook or pin back the four flaps. Simply turning the parts over without cutting or tearing anything, trace out as far as possible the alimentary canal, noting the narrow **oesophagus** entering into the **stomach** about the middle of its concave upper portion, the pyloric end of the stomach placed on the right side and continuous with the **small intestine** which is not distinctly divisible into duodenum, jejunum and ileum, the *large* dark thin-walled **cæcum**

having a shallow spiral constriction around it, the rather thick-walled, light coloured **appendix** proceeding from the end of the cæcum, the **large intestine** of much smaller diameter than the cæcum, much puckered in the first part of its course, less puckered in its median portion, and becoming soon quite smooth and passing without change into the **rectum**. The latter part of the large intestine and the rectum usually contain balls of fæces,

4. Trace out the **mesentery** which supports the intestine; observe its continuity with the **peritoneum** or membrane lining the abdominal cavity, note the manner in which the blood-vessels run in it.

Observe in the dog the loose fold of mesentery loaded with fat, hanging from the lower border of the stomach and forming the *great omentum*.

5. Observe the **spleen**, an elongated dark red body lying near the broad end of the stomach to which it is attached by a mesenteric fold (gastro-splenic omentum).
6. Turn the stomach over to the left<sup>1</sup>, gently stretch out the duodenum and observe in the mesentery belonging to it, the diffuse, pale-red **pancreas**; trace the entrance of the pancreatic duct as a pale thin band into the duodenum: this occurs rather more than a foot below the pylorus, where the duodenum turns back on itself to form a loop.

<sup>1</sup> Right and left are used throughout for the right and left of the animal.

In the dog the pancreatic duct is close to the entrance of the bile duct (see § 14).

Observe the **mesenteric lymphatic glands**, small greyish white lumps, more abundant in the duodenal mesentery than elsewhere.

7. Turning the stomach and intestines over to the right side observe the **dorsal aorta**<sup>1</sup> and **inferior vena cava** lying close together in the median line, trace the aorta upwards to the point where it descends through the diaphragm, tearing through the mesentery as little as is consistent with tracing the aorta.
8. Note the right **suprarenal body**, small, ovoid and yellowish white, lying close to the aorta, carefully tear away the connective tissue above and medially of this and note the **solar plexus** consisting of three or more greyish semi-transparent ganglia connected by bundles of pale nerve fibres. Into the laterally placed ganglion runs the main branch of the **splanchnic nerve**, trace this up alongside the aorta as far as the diaphragm.
9. Note the **cæliac artery** given off by the aorta a little below the diaphragm, and the **superior mesenteric artery** given off somewhat lower down, possibly underneath the suprarenal body, and a little farther down, the **renal artery**, run-

<sup>1</sup> When an artery and a vein run together, as here, they may be distinguished by the artery having thicker walls and containing less blood than the vein; the artery too has generally a bluish-white tint whilst the vein has generally a dark red tint with a tinge of blue.

ning to the hilus of the kidney: note the **renal vein** running parallel to the renal artery into the vena cava. Follow the superior mesenteric artery a short distance and observe the branches given off to the pancreas, these are more easily seen when the intestines are turned to the left.

10. Tearing through the mesentery around the lower part of the œsophagus, observe the right and left **pneumogastric nerves** (cp. C §§ 17, 24,) dividing into several fibres which spread out over the stomach. One or more branches may be traced to the solar plexus. Observe the number of pale nerves which are given off by the ganglia of the solar plexus; bundles of them may be followed along the cæliac, mesenteric and renal arteries.
11. Then turning the stomach and intestines over to the left side, carefully tear away the mesentery over the aorta and note the right splanchnic nerve close beside it, trace the nerve on its course (being careful not to puncture the vena cava) past or underneath the right suprarenal body into a ganglion a little removed from the rest of the solar plexus.
12. Lift up the stomach, and viewing from the right the mesentery below it, note the **portal vein**, a large vein dividing close to the posterior surface of the liver and running into it. This vein is formed by the union of the **lieno-gastric** and **mesenteric veins**, the former is much the smaller and joins the latter close to the liver;

follow for a short distance the course of the mesenteric vein, noting the small numerous branches received by it from the pancreas. Viewing the mesentery from the left side note the juncture of the splenic and gastric veins to form the lieno-gastric.

13. Trace out the branches of the cæliac artery; it first gives off the **splenic artery** which besides giving off a row of smaller arteries to the spleen sends several branches to the greater curvature of the stomach and some small branches to the pancreas, it then gives off at short intervals branches to the lower part of the œsophagus, the stomach and the upper part of the duodenum and a branch, the **hepatic artery**, which runs to the liver.

In the dog, pull the spleen downwards and to the left away from the stomach, a branch of the *lieno-gastric artery* will be seen sending branches to the spleen and to the greater curvature of the stomach; the corresponding veins are best seen on turning the spleen over towards the stomach. Double ligature and cut through these vessels, pull the spleen downwards as before, a smaller branch of the lieno-gastric artery and vein will be seen; centrally of the lieno-gastric vessels will be seen two or more *gastric* and *pancreatic arteries* and *veins*. Pull the pancreas to the left over the spleen and note the junction of the lieno-gastric and mesenteric veins. Then pull the duodenum over the part of the pancreas previously showing and

note the fairly large vein from the pancreas and the upper part of the duodenum joining the previously mentioned vein to form the *portal vein*; note also the branch from the cæliac axis dividing into the hepatic artery and an artery supplying the greater part of the pancreas and the upper part of the duodenum; it then gives off branches to the lower part of the œsophagus and the stomach and finally divides into two branches, one the *hepatic artery* going to the liver, the other going to the lower part of the stomach and the upper part of the duodenum (with branches to the pancreas).

14. Turning the liver up towards the diaphragm, the **gall-bladder** will be seen in a hollow on the under surface of the posterior right lobe: trace the cystic duct or duct from the gall-bladder to the point where it joins the **hepatic duct**, proceeding from the liver itself; trace the united duct or common bile duct into the duodenum, close to the pylorus.
15. Ligature the œsophagus and the rectum and cut through both, the former above the ligature the latter below it. Turning the intestine to the right, cut through the mesentery close to its abdominal attachment and remove from the abdomen the alimentary canal and its appendages except the liver. Observe now the position and form of the liver, especially in relation to the diaphragm.
16. Pull the liver down from the **diaphragm**,

through the transparent tendon of the diaphragm the lungs will be seen in close contact with it. Puncture the tendon on the right side and note the collapse of the right lung as soon as air enters the pleural cavity.

17. With the liver still pulled down, note the short **hepatic veins** proceeding from the liver to join the vena cava inferior just below the diaphragm. Cut through the hepatic veins as close to the liver as possible and remove the liver.
18. Cut open one of the hepatic veins and trace it in this way back into the substance of a liver lobe. Observe on its inner surface the opening of numerous smaller veins; cut through the lobe near its base, and try to distinguish the portal veins from the hepatic by the small bile duct and small thick-walled artery running alongside the former.
19. Cut away the mesentery from the alimentary canal, and trace out the latter along its whole length, observing more fully the features mentioned in § 3, and noting in addition one or more white patches (Peyer's patches) on the free surface of the ileum, due to clumps of lymph-follicles; also note the connection of the cæcum with the small and large intestine, the thin walls of the cæcum and the thicker spotted walls of its appendix.

Note in the dog, the wider œsophagus entering into the stomach nearer the cardiac end than is the case with the rabbit; note also the shorter



length of the intestine, the small cæcum, and the less difference between the large and small intestines.

The small intestine may be washed out by tying a funnel into the duodenum, and letting water from a tap stream down the funnel. The large intestine may be similarly treated.

20. Cut through the stomach along the lesser curvature, throw away its contents and wash the mucous membrane. Note that the mucous membrane of the greater curvature is pale red, that of the pylorus is greyish-white and semi-transparent. The contrast is more marked when the whitish superficial layer of mucous cells is removed.

The mucous membrane may be used to prepare a glycerine extract of pepsin (cp. Lesson XVI.).

21. Wash out the duodenum, its inner surface has a velvety look which is characteristic of the mucous membrane of the small intestine; it is caused by the villi, examine these with a lens. Observe the openings of the biliary and pancreatic ducts, and carefully pass bristles through them into the ducts.
22. Cut open a piece of the large intestine, wash it, and with a lens examine its inner surface; it has no villi.
23. Note again the position of the suprarenal bodies.
24. Note the position of the **kidneys**, the left being much nearer the pelvis than the right; observe on either side the **ureter**, a pale semi-transparent

- duct passing downwards from each kidney over the muscles of the back towards the middle line; trace them to their entrance into the **urinary bladder**.
25. Trace out the renal artery and vein noted in § 9, follow them into the substance of the kidney. Divide one kidney longitudinally, note the single pyramid opening into the pelvis.
  26. In dissecting a female rabbit, observe the **uterus**, with its two cornua, from each cornu proceeds a **Fallopian tube** which taking a winding course upwards for some little distance ends in a clump of processes or fimbriæ. Near the end of each Fallopian tube a little below the kidney will be seen a small, ovoid spotted body, the **ovary**.
  27. In dissecting a male rabbit, observe in each side of the lower part of the abdominal cavity a white convoluted tube the **vas deferens**. Cut through the symphysis pubis with bone forceps, stretch the halves apart and cut away as much bone on each side as may be necessary. Trace the vasa deferentia downwards cutting open the scrotal sacs; each vas deferens is continuous with a coiled mass of tubes, the **epididymis**, attached to one side of the **testis**. Note that the smooth membrane, tunica vaginalis, lining the scrotal sacs is continuous with the peritoneum.
  28. Lay open the **bladder**, observe its neck ending in the urethra, note the openings of the ureters into the dorsal part of the bladder and in the male the openings of the vasa deferentia near its neck.

- B. 1. Make a median incision over the skull from the nose to behind the level of the ears. Reflect the skin on each side. Cut away the attachment of the muscles of the neck to the occiput until the occipito-atlantoidean membrane between the occiput and the atlas is laid bare. Carefully divide this with scissors and observe the medulla oblongata.
2. With a trephine saw through the roof of the skull in its broadest part, a little behind the orbits, working very carefully when the bone is nearly sawn through. With a lever raise the circular piece of bone and remove it. Then with the bone forceps cut away piecemeal the rest of the roof of the skull.
3. Note the thickish membrane, the **dura mater** covering but not attached to the brain, it dips down between the cerebral hemispheres as the *falx cerebri* and between the cerebrum and cerebellum as the *tentorium*; cut away the dura mater and observe the very thin vascular membrane, the **pia mater**, clinging to the surface of the brain.
4. Make a rough sketch of the exposed cerebrum, cerebellum and medulla oblongata for comparison with the same parts in the dog. Note particularly that in the rabbit the **cerebral hemispheres** are smooth and that the olfactory lobes are directly in front of the cerebral hemispheres, being separated from them by a constriction only.

5. In the dog
  - a. The dura mater is much thicker and the pia mater more obvious.
  - b. The cerebral hemispheres have deep fissures.
  - c. The pia mater dips down into the fissures, above the pia mater and bridging over the fissures may be observed the thin transparent arachnoid membrane, also distinctly visible as a covering to the pia mater at the base of the brain. In the space between the arachnoid and pia mater is contained the clear watery sub-arachnoid (or cerebro-spinal) fluid. A smaller quantity of fluid also exists between the arachnoid and dura mater.
  - d. Compare the exposed surface with the sketch made of the surface of the brain of the rabbit, noting the relative sizes of the cerebrum and cerebellum in each.
6. With a scalpel divide the front of the cerebral hemispheres from the olfactory lobes. Lift up with the handle of a scalpel the extreme front of the cerebrum, and turning it backwards bring into view the optic nerves. Cut these through with a sharp pair of scissors close to the skull. Still turning the brain back cut through successively all the other cranial nerves. A little behind the optic nerve is the small but evident third nerve (motor oculi), close behind this the considerably smaller fourth nerve (trochlear), farther back in the hollow behind the attachment of the tentorium lies the thick fifth nerve, to the median side of which the small sixth

(abducens) is fairly conspicuous. A little behind and to the outside of the fifth, in the hard petrous bone are seen together the seventh (facial) and eighth (auditory). Some distance back and nearer the middle line come the ninth (glossopharyngeal), tenth (pneumogastric), and the small eleventh (spinal accessory). Lastly, still farther back is the twelfth (hypoglossal). Cut through the spinal cord below the medulla oblongata, and remove the brain entirely. The outlying lateral portions of the cerebellum will probably be left in the skull. Do not injure the skull in attempting to get these out<sup>1</sup>.

7. Cut and scrape away the tissue above the cervical vertebræ; with bone forceps remove the arches of the vertebræ and cut them away at the sides piece by piece so that the spinal cord is well exposed. Pull the cord a little to one side and note the nerves running into it, one between each pair of vertebræ. Carefully cut through the dura mater and pull it up with forceps, a row of fine nerve fibres will be seen issuing from the spinal cord; they converge and form one bundle the **posterior root** of the spinal nerve. Cut through these filaments, and pull the dura mater a little farther from the spinal cord; ventrally of the above set of fine nerve fibres will be seen another similar set which unite and form the **anterior**

<sup>1</sup> The brain may be placed in spirit to harden and be dissected later: most of the points of structure of the dog's brain given in Lesson xxx. can also be made out on the rabbit's brain.

**root** of the spinal nerve. Observe carefully the roots on the outside of the *dura mater*, they join almost immediately forming the nerve trunk, on the posterior root at or a little before its junction with the anterior root note the swelling caused by the **spinal ganglion**.

- C. 1. Examine again the diaphragm (cp. A § 16). Observe the large central tendon, with the vena cava and œsophagus passing through and tightly attached to it. The muscular part of the diaphragm consists of a costal and vertebral portion. The former is attached by short tendons to the ribs and sternum. The latter is attached to the upper lumbar vertebræ; it is a somewhat thick mass of muscle divided into right and left portions by the descending aorta, the right is much the larger; the two form the pillars of the diaphragm. Pull down the diaphragm by its pillars, on its unpunctured side the lung will follow it.
2. Observe the **pectoral muscle** proceeding from nearly the whole length of the sternum to the humerus, cut it through together with the vessels and nerves going to the arm and note its attachments.
3. Several muscles will now be exposed, note the **serratus anticus major** proceeding from the lower part of the internal border of the scapula to the 3rd to 9th ribs inclusive. Cut it through and reflect the parts.

4. Note the **scalenus medius** running from the neck to the upper ribs (2nd to 5th); cut this through where it is inserted into the ribs and turn it forward, the **scalenus anticus** will be seen attached to the 1st rib at its junction with the costal cartilage.
5. The **serratus anticus minor** running from the upper part of the internal border of the scapula to the lower cervical vertebra and 1st and 2nd rib.
6. The **serratus posticus**, a thin inconspicuous muscle proceeding by rather a long broad tendon from the cervical vertebræ and dorsal fascia. It is inserted into the 4—12th ribs about the middle part of their course.
7. These muscles having been cut through the small **scalenus posticus** will be seen running from the neck to the 1st rib laterally of the scalenus anticus. The three scaleni originate from one or more of the transverse processes of the 4th to 7th cervical vertebræ.
8. Note the thick muscle the **longissimus dorsi** covering the ribs dorsally; cut away this and the adjoining muscles and note the inconspicuous **levatores costarum** proceeding from the transverse processes of the dorsal vertebræ to the ribs below.
9. Clear away all muscles and tendons attached to any two of the ribs (say 4th and 5th) except the intercostal muscles joining them. Note the **external intercostal** muscle, the fibres run

downwards and ventrally, and are absent between the costal cartilages, here the **internal intercostal** muscle is seen; carefully remove the external intercostal, and so follow the internal intercostal towards the vertebræ; the fibres run downwards and ventrally and near the vertebræ are scanty or absent.

10. Observe more closely the costal cartilages and their connection with the ribs and sternum.

11. The above mentioned muscles, especially the thinner ones, should also be observed in the dog, where they are larger. There are some differences in arrangement.

The *pectoral* has an upper portion which runs not to the scapula but to the humerus.

The *serratus anticus* runs from the whole length of the internal border of the scapula to the lower cervical vertebræ and first seven ribs.

The origins and insertions of the *scaleni* are somewhat different.

The *serratus posticus* is divided as in man into an upper and a lower portion (s. p. superior and s. p. inferior.)

12. Cut through the costal cartilages on either side close to the sternum, cut through the muscles between the 2nd and 3rd and the 8th and 9th ribs, with bone forceps cut through the 3—8th ribs dorsally and remove them. The pleural cavities will be seen to be separated from one another by the **median parietal portions of the pleuræ**, between these is a space, the **mediastinum**. From the surface of the lungs a shred of a fine



membrane, the visceral portion of the pleura, may be torn; note that at the base of the lungs this is continuous with the parietal portion of the pleura attached to the walls of the chest and bounding the mediastinum. Note the position of the heart.

13. In the mediastinum attached to the pleura note on either side the **phrenic nerve** distributed to the muscular fibres of the diaphragm.
14. With fine forceps tear off the membrane over the phrenic nerve in the middle part of its course; another membrane will be seen underneath, outside of which the phrenic runs, this is the parietal layer of the **pericardium**; cut it through, the heart will be seen to lie in a bag formed by it. Remove the middle and posterior portions of the sternum. Trace the connection of the parietal layer of the pericardium with the covering of the heart and of the roots of the great vessels.
15. Turning in the dog the heart and lungs over to the right, pull up the large aortic trunk, and note the almost transparent **thoracic duct**, lying alongside the œsophagus; trace it up to its termination into the venous system (at the junction of the left jugular and left sub-clavian vein, cp. § 20). With a little care the thoracic duct may also be traced in the rabbit.
16. Prolong the median skin incision to the chin and reflect the skin as far as possible. Observe on

- each side the external jugular vein arising anteriorly from two branches: avoid puncturing it.
17. Cut through in the middle line the thin superficial muscle (platysma); draw it to one side, clearing away the connective tissue. Lying on either side of the muscles immediately surrounding the trachea will be seen the sterno-mastoid muscle (cp. § 28) diverging from the lower part of the neck. Cut through the connective tissue on the inner side of one sterno-mastoid and draw the muscle outwards; there will be seen the **common carotid artery**, and, running along the outer side of this, the **pneumogastric nerve**. Free in one place the carotid, and lift it up with a hook. In the underlying connective tissue will be seen two nerves more or less closely united by tissue; the larger is the **sympathetic**, the smaller the superior cardiac (**depressor**).
18. Clear away the connective tissue from the artery. Draw the larynx from the carotid by means of a hook to which is tied a string having a weight at the end. Passing *over* the carotid at the level of the larynx will be seen the descendens noni, a branch of the 12th nerve. Cut this through and remove it entirely. Passing *underneath* the carotid nearly at the same level is the **superior laryngeal** branch of the pneumogastric. Trace this *with especial care*; soon after it leaves the pneumogastric it will be seen to give off a small nerve, the depressor. Follow this down the neck, separating it from the sympathetic. Sometimes

the depressor receives a branch direct from the pneumogastric; occasionally this is its sole origin.

19. Remove the first rib and the remains of the sternum, avoiding any injury to the tissues below. Observe the **thymus**, a fatty looking body covering the roots of the great vessels. It may be torn away.
20. Trace out on each side the junction of the **external jugular** and **subclavian veins** to form respectively the **right** and **left venæ cavæ superiores**: near the junction ends the **internal jugular vein**, this brings blood from the brain and may be traced from the foramen jugulare (cp. E. § 21) down the neck laterally of the common carotid and vagus.
21. Observe the right vena cava superior passing straight down to join the right auricle; the left vena cava superior passing obliquely downwards underneath the left auricle to join the right auricle; and the inferior vena cava passing upwards from the diaphragm to join the right auricle.
22. Trace up one **phrenic** nerve. It makes its way out of the thorax by the side of the superior vena cava, and then passes beneath it. Place a double ligature round the vein and divide between the ligatures. Follow up the phrenic to its origin from the 4th and 5th (and also from the 6th and 7th) cervical nerves.

23. Trace out the arch of the aorta by clearing away the tissue from its upper surface. Take care not to injure the pneumogastric nerves (see next section). Observe on the right side the **innominate artery**, which gives off first the **left common carotid**, and then divides into the **right subclavian** and **right common carotid**; on the left side the **left subclavian**. Note the vertebral artery on either side proceeding from the subclavian. On a level with the anterior part of the larynx, note the division of the common carotid into **external carotid** and **internal carotid**. The former curls round the angle of the jaw, the latter enters the skull a little in front and to the median side of the tympanic bulla.
24. Trace both pneumogastric nerves downwards, observing the **recurrent laryngeal** branches passing on the right side round the subclavian artery, and on the left round the aorta. Place a double ligature round the innominate artery and divide between the ligatures. Trace the recurrent laryngeal nerves along the back of the trachea to the larynx. Pursue the main pneumogastric trunks on the œsophagus to the point where they were seen in A, § 10.
25. Trace the sympathetic nerve downwards to the **inferior cervical** ganglion lying a little above the subclavian artery, and close to the vertebral artery; follow it thence to the **first thoracic ganglion**.

Observe the branches going from these ganglia towards the heart. Observe also the depressor nerve passing to the heart.

From the first thoracic ganglion trace down the thoracic sympathetic nerve trunk lying on the heads of the ribs with the ganglia (twelve in all) and the **rami communicantes** connecting each ganglion with its corresponding spinal nerve.

23. Trace out the **splanchnic** nerve on one side; it will be found to separate from the sympathetic at the 8th, 9th, or 10th thoracic ganglion. At first sight it appears to be the continuation of the sympathetic instead of a branch of it; since the sympathetic at its lower part becomes more transparent, and running in a groove between two muscles, is rather easily overlooked. The splanchnic receives branches from each of the thoracic sympathetic ganglia below its origin.
27. Tie a tube in the trachea and distend the lungs, note the appearance of the distended lungs. Cut out the heart<sup>1</sup> with the lungs attached, and trace the **pulmonary arteries and veins**.
28. Having reflected on either side the skin of the neck of the dog, and cleared away the fascia of connective tissue, observe the muscles underneath.
- a.* The *sterno-hyoid* close to the median line. It runs from the sternum to the hyoid bone.

<sup>1</sup> The heart may be dissected in the manner given for the sheep's heart in Lesson XII.

- b. The *sterno-thyroid* lying laterally of (a) and for the greater part of its course close to it, it runs from the sternum to the thyroid cartilage of the larynx.
- c. The *thyro-hyoid*, a small muscle running from the thyroid cartilage to the hyoid bone, in the upper part of its course it lies laterally of (a).
- d. The *sterno-cleido-mastoid* lying laterally of (b) and covering it near the hyoid bone, thence it proceeds outwards, and disappears under a white oval mass, the submaxillary glands.

These muscles may be dissected in the rabbit also, the representative of the sterno-cleido-mastoid has however no clavicular attachment and hence is called the sterno-mastoid, it does not come in contact with the submaxillary gland.

29. Carefully separate the sterno-mastoid from the sterno-thyroid; the sympathetic-pneumogastric trunk and the carotid artery will come into view.

Observe the following points in which the dog differs from the rabbit :

- a. There is but *one* superior vena cava formed by the junction of the *two innominate veins*.

(The arrangement of the main arteries is usually that described above for the rabbit, but considerable variations occur.)

β. There is in the neck no separate nerve corresponding to the depressor in the rabbit.

γ. The sympathetic and the vagus run in the neck in a thick sheath common to both. At the lower end of the neck, the sympathetic joins the inferior cervical ganglion. From the ganglion run several pale nerves to the heart and lungs, and receives two white ones—the annulus of Vieussens—from the first thoracic ganglion. The latter receives rami from the lower cervical and first two dorsal nerves, of these the 2nd dorsal only (the 10th spinal nerve) gives an obvious white as well as a grey ramus to it.

30. Clear away any muscles that may remain around the lower part of the larynx; on either side of it is attached a thin, dark red lobe of the **thyroid gland**, the lobes run a short way down the trachea, and there join over the ventral surface of the trachea by a very thin connecting piece.

D. 1. Cut through the skin in the front of the thigh and turn it back on either side; in the upper median part blood-vessels will be dimly seen through the thin sartorius muscle; cut through this muscle and note the **femoral** (crural) **artery** and **vein**, and the **crural nerve** running side by side; trace the artery upwards, it unites with other arteries to form the common iliac, which with the common iliac of the other side forms the abdominal aorta; trace similarly the femoral vein to the common iliac vein and

the inferior vena cava. Follow the crural nerve up to the spinal cord, it arises chiefly from the 5th lumbar nerve (receiving branches also from the 6th and 7th).

2. Remove the skin from the back of the thigh, cut through the tendonous line seen over the femur and pull the outside mass of muscle outwards, the large **sciatic nerve** will be seen, trace this to the top of the thigh, then turn the rabbit over and follow the nerve to its origin from the spinal cord; it arises chiefly from the 7th lumbar and 1st sacral nerve (receiving branches from the 6th lumbar and 2nd and 3rd sacral nerves.)

E. The Student should have a rabbit's and a dog's skull before him, and make out the several openings by which the nerves spoken of below issue from the skull.

1. Carry up to the chin the median skin cut and reflect the skin, place the head on one side; just in front and ventrally of the base of the ear will be seen the thin dorsal part of the **parotid gland**, often much hidden by fat tissue; the gland stretches ventrally a little past the angle of the jaw.
2. From the anterior border of the parotid gland, issues the greater part of the **facial nerve** (7th) dividing into several branches which run



forwards across the masseter muscle to their endings in certain muscles of the face.

3. The **duct of the parotid** (duct of Stenson) runs forward with the facial nerve, from the gland; it is small, thin-walled and inconspicuous, it may sometimes be made evident by pressing on the gland and so forcing some fluid into it. The branches of the facial should be carefully isolated close to the gland, the connective tissue being cut through with a fine pair of scissors as close as possible to the nerves lest the duct be inadvertently severed; on pulling the nerves to one side the duct will be seen, follow it forwards to the anterior edge of the masseter where it dips down to the mouth; make a small cut in it with scissors and pass a bristle down it.

In the dog the duct is much more obvious, the facial nerve does not accompany it.

4. Cutting through the parotid gland, trace the facial nerve to its exit from the skull by the stylo-mastoid foramen; observing the branches going to the muscles of the ear.
5. Behind the parotid gland will be seen a nerve running from the under surface of the sterno-mastoid muscle (cp. C. § 21) dividing into two branches, and passing up the ear. This is the **great auricular**, which arises from the 3rd cervical nerve, and is the main sensory nerve for the ear. Trace as far as possible its course in the ear.

6. In the dog, reflect the skin of the head, note again the position of the *submaxillary gland* (cp. C. § 28 *d.*) as seen from the surface; it lies between two large branches of the jugular vein; attached to the inner part of the posterior extremity of the lower jaw will be seen the digastric muscle; clear away the connective tissue surrounding it, cut it through, taking care not to injure the parts beneath, and reflect the cut ends; the *submaxillary duct* (duct of Wharton) will be seen running from the gland, trace it forwards, it runs underneath (dorsally of) a muscle with transverse fibres, the mylohyoid, cut through this, turn the lateral part as far back as possible, taking care that the fascia on its lower surface is not attached to it and follow the duct forwards.
7. Attached to the anterior end of the submaxillary gland and stretching for some little way along its duct will be seen the smaller *sublingual gland*, from this runs the *sublingual duct*, alongside and laterally of the duct of the submaxillary gland.
8. A short distance from the lower border of the mylohyoid muscle the *lingual nerve* will be seen crossing the ducts and running on to the tongue: pull the tissues on which the lingual rests well away from the jaw, about three quarters of an inch centrally of the point where the lingual crosses the ducts, it will be seen to give off a small nerve the *chorda tympani*. This curves towards the ducts and then runs alongside them towards the sublingual and submaxillary glands.

9. Trace the ducts peripherally, they unite and open underneath the tongue; trace the lingual nerve peripherally, it supplies chiefly the tip of the tongue.
10. In the rabbit there will be seen lying between the angles of the lower jaw the tolerably compact but soft **submaxillary glands** touching one another in the median line. Each gland is laterally in contact with the ventral lobe of the parotid, its tint is redder than that of the parotid; pull the submaxillary gland laterally and backwards, its small **duct** will be seen running from it over the muscle attached to the inner surface of lower jaw, and then underneath (dorsally of) the digastric muscle, which here has a conspicuous tendon; cut through the digastric and trace the duct forward underneath the mylohyoid muscle; a short distance from the lower border of the mylohyoid this duct is covered by the lobules of the small sublingual gland, turn this back, the lingual nerve will be seen crossing the duct, with care in dissection fine nerve fibres, **chorda tympani fibres**, may be seen running from the lingual nerve to the sublingual gland and to the duct of the submaxillary gland, the latter fibres are too small to follow towards the gland itself.
11. Now follow up the **pneumogastric** nerve from the place where it was left in C. § 18. A little above the superior laryngeal branch will be seen the pharyngeal nerve, and higher up still a

- fusiform enlargement, the **ganglion** of the trunk.
12. Note the **hypoglossal**, a large nerve running across the pneumogastric a little centrally of its ganglion. Trace it forwards to the muscles of the tongue.
  13. Follow up the sympathetic nerve, it has, at about the level of the ganglion of the pneumogastric, a considerable enlargement, the **superior cervical ganglion**; observe the fibres which run from this along the carotid artery and its branches.
  14. In the dog the sympathetic and pneumogastric nerves which run in a common sheath in the neck (cf. C., § 28 ( $\gamma$ )) separate from one another a little distance from their respective ganglia.
  15. Partly saw through the symphysis menti, then use a lever and force the rami asunder, and in the following dissection cut through or remove any muscles necessary.
  16. Trace the lingual backwards. It will be found to join the inferior dental (a large nerve entering into the lower jaw), to constitute, with other branches, the **inferior maxillary** nerve. Trace this back to the front edge of the tympanic bulla.
  17. Note in the dog the small nerve, *chorda tympani*, which joins the lingual soon after the latter branches off from the inferior dental; trace the chorda tympani centrally, it will be found to make its exit from the tympanic bulla

close to the Glaserian fissure. Break through the bulla, and observe the chorda running across the tympanic cavity over the handle of the malleus (cp. Lesson xxviii.). This course of the chorda tympani may be followed in the rabbit, but the dissection is not easy.

18. Note also in the tympanic cavity the very small nerve running over the promontory, or projection of the cochlea. This is Jacobson's nerve, a branch of the 9th.
19. Trace up the pneumogastric beyond its ganglion, to its exit from the skull by the foramen jugulare. Note, passing from the skull with the pneumogastric, the small **spinal accessory** nerve behind and the **glosso-pharyngeal** in front; the communicating branches between these nerves may be neglected.
20. Trace the glosso-pharyngeal forwards to the tongue and pharynx. It runs nearly in the same direction as, but at a higher level than, the hypoglossal, and may be traced to the hinder part and to the sides of the tongue.
21. Cut through the above three nerves, a little distance from the skull, break away with small bone forceps the tympanic bulla, and trace more thoroughly the exit from the skull of these nerves and of the hypoglossal. The latter issues through the condyloid foramen, which is separated by a distinct width of bone from the foramen jugulare, through which the other three issue.

22. Saw through the base of the skull and the face, from the occiput to the nose, a little on one side of the median line.

The nasal septum will be seen dividing the nasal cavities except posteriorly. Note the **anterior** and **posterior turbinate bones** both consisting chiefly of thin folded laminae, pass a bristle through the anterior nasal opening into the nasal cavity, using bone forceps and scissors trace the passage from the nasal cavity through the posterior nasal opening into the pharynx and trachea; note that the posterior turbinate bones are not in the direct course between the anterior nares and the trachea. Cut through the septum nasi dorsally close to the nasal bones, and remove the nasal bones, note that the posterior turbinate bones and the posterior dorsal part of the septum are covered with a yellowish mucous membrane which is thicker than that lining the rest of the nasal cavities; this is the olfactory part of the mucous membrane (**Schneiderian membrane**). Trace the **olfactory nerve** forwards from the brain; it divides into a number of fibres which run to the Schneiderian membrane.

23. Looking down into the pharynx, observe the **epiglottis** and the way in which it when pushed backwards folds over the opening to the larynx.

Put the larynx of the dog into weak spirit for dissection later. (Lesson xxxii.)

24. Look at the side of the pharynx for the opening

of the Eustachian tube, pass a probe up it into the tympanic cavity. Pass another probe down the meatus externus and, rupturing the membrana tympani, make sure that the first probe has entered into the tympanic cavity.

25. Remove one eye from its orbit, cutting through the tissues close to the eye. In the anterior part of the orbit note the white **Harderian gland**; in the anterior lower part the pale red **infra-orbital gland**, the duct of which opens into the mouth near the upper molars; and the **lachrymal gland** pale-red like the infra-orbital in the posterior part of the orbit. Observe the point of entrance of the optic nerve into the orbit.

In the dog the muscles of the globe of the eye may be dissected out, after removing with bone forceps the roof of the orbit.

26. Immediately below, and in front of the eye, the **superior maxillary nerve** will be found issuing from a foramen in the superior maxillary bone, to supply the skin of the face, &c., with sensory fibres. Cutting away the bone with a small pair of bone forceps, trace this nerve back along the floor of the orbit.

27. In the upper part of the orbit of the dog note the *ophthalmic nerve*. It passes from the front of the orbit to the forehead.

28. The superior and the inferior maxillary nerves and the ophthalmic, when traced back, will be found to unite into one large nerve, the fifth or

**trigeminal.** Observe on the nerve at the junction of the three branches, the swelling of the **Gasserian ganglion.**

Observe also that the nerve in leaving the brain has two roots, a small and a large, that the small root passes beside the ganglion on the large root, without entering into it, and that the fibres of the small root are, beyond the ganglion, almost entirely confined to the third or inferior maxillary branch.

29. Cut out the tongue taking care to remove the whole of it; on either side of the posterior upper surface, will be seen a small oval patch, the **papilla foliata** or lateral taste organ; note the parallel ridges running at right angles to the long axis of the papilla.

F. As an introduction to the methods of preserving and hardening tissues, the following should be done by each student. The tissues should be removed from the rabbit as soon as possible after it has been killed, and sections should be cut when the Lessons dealing with the several tissues are being worked through.

1. Cut out from the greater curvature or fundus of the stomach a piece about 1 c. m. square, wash it for a moment in NaCl. .6 p.c. to remove any acid or any food substance on the surface of the mucous membrane; with hedgehog quills or small pins fasten it out on a piece of cork with



the muscular surface downwards, stretching it slightly, and place it in alcohol about 75 p. c. for about an hour, then remove to 95 p.c. alcohol for a fortnight; keep in 75 p.c. alcohol.

2. Cut out of the small intestine a piece about two inches long; tie into each end a short glass tube with lumen about 5 m.m. in diameter, over the free end of each glass tube slip a piece of india-rubber tubing; by means of a syringe wash out the piece of intestine with NaCl .6 p. c. for about twenty seconds, then inject chromic acid .2 p. c. When the salt solution has been displaced by chromic acid tie or clamp the peripheral piece of tubing, inject a little more chromic acid to distend slightly the intestine, and tie or clamp the central piece of tubing. Place the distended intestine in ten times its bulk of chromic acid .2 p. c. In two to three days cut off both ends of the intestine, cut it open longitudinally, and place it in fresh chromic acid .2 p. c.; in about ten days place it in water for some hours, and then in alcohol 30 p.c.; on the next day transfer it to alcohol 50 p.c. renewing the alcohol as long as it becomes coloured and finally place the tissue in strong spirit.
3. Take a piece of costal cartilage about 5 m.m. long and place it in about 10 c. c. of saturated aqueous solution of picric acid; after about ten days wash it well with water and place for a day in 50 p.c. alcohol, then transfer to strong spirit.

4. Take of the sciatic or other large nerve a piece about 10 m.m. long and place it in about 10 c. c. of ammonium bichromate 2 p.c. In a week renew the ammonium bichromate; in this fluid it may be kept until sections are required, or in a month or more it may be washed with water and placed in spirit as in § 2.

## LESSON II.

### STRUCTURE OF BLOOD.

#### A. BLOOD OF FROG OR NEWT.

1. Having destroyed the brain and spinal cord of a frog<sup>1</sup>, cut through the skin in the median ventral line, cut transversely through the lower part of the sternum just above the epigastric vein, and expose the heart. Cut off the tip of the ventricle; with a glass rod transfer a *small* drop of blood to a glass slide and place on it a cover-slip.

Examine it under the microscope with a low magnifying power<sup>2</sup> and observe the numerous corpuscles floating in the plasma.

Examine it with a high magnifying power<sup>2</sup> and observe the **red corpuscles**; if a large drop of

<sup>1</sup> Cp. Appendix.

<sup>2</sup> For convenience the term 'low power' will be used throughout for a combination of lenses which magnifies less than 100 diameters, and the term 'high power' for a combination of lenses which magnifies more than 300 diameters. In Zeiss' microscope, objective A with ocular 2 magnifies 55 diameters, with ocular 3 it magnifies 75 diameters; objective D with ocular 3 magnifies 320 diameters, with ocular 4 it magnifies 440 diameters. If the tube be drawn out the

blood has been taken the corpuscles will probably form a continuous layer, in which case a drop of .6 p.c. sodium chloride solution should be made to run under the cover-slip (cp. § 4).

- a. The red corpuscles are flattened ellipsoids; note their spindle shape as they roll over.
  - b. They appear homogeneous; if however the specimen be not carefully prepared a certain number of the corpuscles will be altered and show a central oval nucleus.
  - c. A single corpuscle is pale yellow, the colouring substance being equally diffused throughout it; when several corpuscles lie over one another they together appear red.
  - d. The great majority are of the same size and tint.
2. Examine the **colourless corpuscles** in parts of the specimen where the red are not very numerous.
- a. They are much fewer than the red.
  - b. They are smaller than the red, but vary considerably in size.
  - c. Most have an irregular form, some are spherical.
  - d. They are colourless and granular; the granules vary greatly in distinctness and size.

magnification is of course greater. The  $\frac{3}{8}$  inch and  $\frac{1}{2}$  inch objectives of English make correspond respectively to the *A* and *D* objectives of Zeiss. With Hartnack's microscope the nearly corresponding lenses are oc. 2 or 3, obj. 3 (low power) and oc. 3 or 4, obj. 7 (high power).

- e.* The nucleus can seldom be made out, except when the corpuscle is very extended. Do not confound a heap of granules or a protuberance with the nucleus.
- f.* Choosing a corpuscle either elongated or having several processes, watch carefully its amoeboid movements; make half a dozen drawings of its outline at intervals of about twenty seconds.
- g.* When a drop of blood is first mounted the colourless corpuscles are usually spherical, they soon begin however to put out processes; if it is desired to watch the movements for any length of time a fresh drop should be mounted and protected from evaporation in the following manner. With a morsel of blotting-paper dry if necessary the slide at the edges of the cover-slip. Keep the cover-slip in place by gently holding a needle against one edge, and, with a small brush, brush carefully the melted paraffin A.<sup>1</sup> (which melts at 39°C.) over the edges all round. The paraffin need not extend more than  $\frac{1}{8}$  or  $\frac{1}{8}$  inch over the cover-slip.
3. *a.* With the aid of a camera lucida<sup>1</sup> make an outline drawing of two or three red corpuscles; substitute for the specimen a stage micrometer<sup>1</sup>, and being careful that the microscope and the drawing-pad are in the

<sup>1</sup> Cp. Appendix.

same positions as before, make a drawing of the micrometer lines over the previously made drawing of the corpuscles; then, the real distance between the micrometer lines being known, the diameters of the corpuscles can be at once read off; thus if the micrometer lines are  $\frac{1}{100}$  mm. apart and in the drawing a corpuscle exactly occupies one division its diameter in that direction is evidently  $\frac{1}{100}$  mm.

The drawing of the micrometer lines may be kept as a scale, and any object drawn under the same magnifying power and with the pad and microscope in the same relative positions may be directly measured by it.

- b.* Substitute for the ordinary eye-piece of the microscope one which has a ledge for supporting an ocular micrometer<sup>1</sup>, the values of which have been determined, the size of the corpuscle can then be at once read off.
4. Mount another small drop of blood, place a small drop of .1 p.c. acetic acid on the glass slide so that it just touches the edge of the cover-slip; place a piece of blotting-paper on the opposite side just touching the fluid at the edge of the cover-slip, the acetic acid will then run under the cover-slip and mix with the blood. Note the changes which take place.

  - a.* In the **colourless corpuscle**, the cell substance becomes more transparent but shews

<sup>1</sup> Cp. Appendix.

several dark granules; a granular nucleus, often irregular or lobed, comes into view, usually more than one nucleus will be seen.

- b. In the **red corpuscles** the nucleus becomes obvious; it is when first seen nearly homogeneous, and oval in outline, later it becomes granular and usually irregularly rod-shaped.
  - c. The red corpuscles swell up owing to absorption of water, most after a time become spherical (if strong acid be used the corpuscles usually preserve their shape).
  - d. They become colourless, the colouring matter being dissolved; occasionally the colouring matter is massed round the nucleus before complete solution takes place (effect of water) and occasionally the nucleus becomes stained yellow by the colouring matter (effect of acetic acid).
  - e. Finally the outline of the corpuscles is seen as a faint line at some distance from the nucleus. Observe the not infrequent eccentric position of the nucleus.
  - f. Some corpuscles are much more readily acted on than others.
5. Irrigate with a strong aqueous solution of Spiller's purple or magenta.
- a. The outline of the red corpuscle becomes distinct, its nucleus stains deeply, around the nucleus a little faintly stained granular

substance is seen which often stretches out to the periphery of the corpuscle in the form of a star. The nuclei of the colourless corpuscles also stain deeply.

6. Place several very small drops of blood two or three mm. apart on a slide and leave for a few minutes, then cover with a cover-slip, and put under a high power. Take a little blood from a freshly killed frog and establish a current underneath the cover-slip from one side of it to the other (cp. § 4). The first small drops will have partially clotted and will serve as an imperfect barrier to the corpuscles in the current; in such places note that the shape of the red corpuscles is easily changed and recovered, and that the colourless corpuscles stick to one another and to the glass more than do the red. After the current has passed a short time largish clumps of colourless corpuscles will be seen.
7. Having destroyed the brain and spinal cord of a frog, expose the heart and cut it across, suck up a little blood in a clean pipette and add it to about five times its volume of 2 p.c. boracic acid, stirring gently. Mount a drop of the mixture at once and observe the red corpuscles with a high power.

The nuclei scarcely visible at first become in a short time rather deeply stained with hæmoglobin; small spheres of hæmoglobin appear also in the body of the corpuscle; occasionally the hæmoglobin may appear to stretch in rays from



the nucleus through the body (if the rays are not seen irrigate with 2 to 5 p.c. salt solution, but in this case be careful not to mistake foldings of the corpuscle for rays). Later the corpuscle becomes spherical and its body colourless. Whilst the earlier changes are taking place some of the corpuscles may be seen to extrude their nuclei.

8. Dilute a little fresh blood with twice its volume of .6 p.c. salt solution ; mount a drop of the mixture and place it aside for an hour or so to clot ; irrigate it with 30 p.c. alcohol and then with Spiller's purple dissolved in water or in dilute alcohol. Note the deeply stained network of fibrin fibrils and the numerous long threads of fibrin running from the broken-down colourless corpuscles.

## B. BLOOD OF MAN.

1. With a needle prick the end of a finger, and squeeze out a *small* drop of blood and mount it (cp. A. § 1). Observe the **red corpuscles**.
  - a. They roll about readily, when the cover-slip is lightly touched.
  - b. Soon after being taken from the body they stick to one another, and, owing to their shape, usually in rouleaux.
  - c. They are biconcave discs. Note that on focussing down on the circular face a darkish centre and a light rim is first seen and then

- a light centre with a darkish rim: when viewed in profile and the centre focussed they appear somewhat dumb-bell shaped.
- d.* They appear homogeneous, their colour is like that of the red blood corpuscles of the frog (cp. A. § 1, *c*).
- e.* Towards the outside of the drop, where evaporation is going on, many of the red corpuscles are crenate.
- f.* They are much smaller than the red corpuscles of the frog. Measure them (cp. A. § 3).
2. Observe the **colourless corpuscles**. They are larger than the red, they resemble the white corpuscles of the frog (A. § 2, *c. d. e.*); to observe their amœboid movements a drop should be protected from evaporation (A. § 2, *g*) and, preferably, warmed to the temperature of the body.
3. Irrigate with .5 p.c. acetic acid (cp. A. § 4).
- a.* The red corpuscles swell up and become spherical, their hæmoglobin is dissolved, leaving the hardly visible stroma. (Effect of water.)
- b.* No nucleus is brought into view.
- c.* The white corpuscles behave like those of the frog (A. § 4, *a*).
4. Count the red corpuscles with Gower's hæmatocytometer in the following manner.  
Fill the larger pipette with sodium sulphate solution of Sp. Gr. 1025 up to the mark on the

stem, it then contains 995 c. m.; empty it into the measuring glass. Fill the small pipette with freshly drawn blood up to the line marked 5 c. m.; empty it into the measuring glass, and with the fluid in the measuring glass wash out the blood sticking to the inside of the tube; thoroughly mix the blood and salt solution with the glass spatula, place a small drop of the mixture in the centre of the glass cell and over it lay a cover-slip, arrange the springs on the cover-slip to keep it in position, and under a high power count the number of red corpuscles in ten of the squares which are marked at the bottom of the glass cell.

Since the depth of the cell is  $\frac{1}{8}$  mm. and the side of each square is  $\frac{1}{10}$  mm., there is beneath each square  $\frac{1}{800}$  c. m. of the mixture, *i.e.*  $\frac{1}{100000}$  c. m. of blood, hence the number of corpuscles in 10 squares multiplied by 10,000 gives the number of corpuscles in 1 c. m. blood.

### DEMONSTRATIONS.

The method of using the simple and Stricker's warm stage.

The 'platelets' of frog's or newt's blood (cf. p. 387).

Specimens to show the chief stages of indirect nuclear division (cf. p. 395).

**NOTE.** If the brain of a frog be destroyed, a drop of curari injected under the skin, and the frog be left for a day in about  $\frac{1}{4}$  inch of water, the lymph sacs will become filled with lymph containing numerous white corpuscles, many in a state of active amoeboid movement.

## LESSON III.

### COAGULATION OF BLOOD. CHARACTERS OF PROTEIDS:

1. Observe the coagulation of freshly shed blood<sup>1</sup>; it is at first fluid but soon passes into a jelly which gradually becomes firm; if then placed aside for some time, drops of clear serum will, by the shrinking of the fibrin, be pressed out on the surface of the clot; later the clot shrinks more or less completely from the vessel squeezing out more and more serum.
2. With a feather stir *slowly* about 10 c.c. of freshly shed blood<sup>1</sup>; a considerable portion of the blood will form a clot on the feather; squeeze out the clot under a stream of water from a tap; the clot shrinks considerably and a small quantity only of **fibrin** is obtained.
3. Repeat § 2, but this time stir *quickly*, filaments of fibrin will be obtained; note that the fibrin is extensible and elastic; leave the defibrinated blood for a day, no further clot is produced.

<sup>1</sup> This will be obtained by the Demonstrator.

4. Place a small drop of fresh blood on a piece of glazed neutral litmus paper, in about ten seconds wipe off the drop, a blue spot will be left showing that the blood is alkaline. Test also the reaction of serum.
5. Apply the Xanthoproteic and Millon's test for proteids (cp. § 16) to fibrin chopped up and suspended in water.
6. Take two test-tubes and in each place a few flocks of fibrin.
  - a. Add water and place in water bath at about 39° C. for a day; the fibrin does not dissolve (it thus differs from albumin and peptone).
  - b. Treat similarly but with dilute (1 p. c.) solution of sodic chloride; the fibrin does not dissolve (it thus differs from globulin).
7. Place two or three flocks of fibrin in a test-tube containing a few c. c. of .2 p. c. HCl, the fibrin soon swells up and becomes transparent; neutralize the acid with  $\text{Na}_2\text{CO}_3$ , the fibrin shrinks to its original size. If the fibrin is warmed with the acid, solution *slowly* takes place, acid-albumin being formed (cp. Lesson IX.).
8. Examine the plasma of horse's blood kept, by means of cold, from coagulating<sup>1</sup>.

<sup>1</sup> The blood is allowed to run from the animal into a tall narrow vessel contained in a much larger one packed with ice, a little salt may be mixed with the ice, but of course not enough to reduce the temperature so much that the blood is frozen; sometimes also a vessel

- a.* Transfer with a pipette 2 or 3 c.c. of the plasma into a small test-tube. Observe the coagulation and compare it with that of § 1. Avoid shaking. Probably the fibrin will adhere so strongly to the sides of the tube that little contraction will take place. On being freed from the glass it will contract. If the clot has already shrunk away from the sides of the vessel, it may since it is colourless be overlooked unless the fluid be carefully examined.
  - b.* Dilute 1 c.c. of the plasma with 50 c.c. of distilled water or normal saline solution. Carefully avoid shaking and leave it till the next day. Observe the fine delicate fibrils of fibrin which are formed.
9. Examine the plasma of blood prevented from coagulating by the presence of neutral salts<sup>1</sup>.
- a.* Remove 1 or 2 c.c. carefully with a pipette, avoiding blood-corpuscles as much as possible, and dilute five to tenfold with water.

filled with ice is placed in the one which receives the blood. Horse's blood is preferable to bullock's or dog's, since it clots less readily and the red corpuscles sink more quickly.

<sup>1</sup> In preventing coagulation by neutral salts, blood is collected in a vessel containing a saturated solution of magnesian sulphate; as the blood runs in, it must be mixed well with the salt solution, preferably by stopping the flow of blood now and then and turning the vessel upside down. There should be about 1 vol. of the salt solution to 4 vols. of blood. The vessel may advantageously be surrounded by ice or by ice and salt. On either method (§ 9 or § 10) clotting sometimes takes place, but the remaining fluid may still give a clot on appropriate treatment.

The mixture will clot very speedily if placed in the warm chamber; less speedily if left at the ordinary temperature.

- b. Remove about 10 c.c. into a small conical glass. Add powdered sodic chloride to excess, stirring but *not more than is necessary to assist the salt to dissolve*. As the point of saturation is reached, a flaky precipitate makes its appearance. If the precipitate be plentiful, remove it with a spatula, put it on a small filter wetted with a *saturated* solution of sodium chloride and wash with small quantities of the same: if the precipitate be small, decant it and the fluid from the undissolved salt; filter, and wash the precipitate on the filter paper with small quantities of a saturated sodic chloride solution. Dissolve the substance so obtained, the **plasmine** of Denis, in a small quantity of distilled water, and filter. Probably a portion of it will not dissolve, having already coagulated. The clear, colourless fluid filtrate will, if set on one side, clot. Avoid shaking after filtration. If a small quantity only of the fibrin factors be present, the fine threads of fibrin, as they are formed, are loosened by the shaking, and contract; thus the more easily recognized gelatinous stage is lost. *This operation is the more successful, the more rapidly it is carried on.*

10. To 2 c.c. of hydrocele or other serous fluid which

has been ascertained not to coagulate, nor to have coagulated spontaneously, add 2 c.c. of fresh blood-serum, gently mix, and put on one side.

After a while, possibly not until after twenty-four hours, the mixture will have coagulated. The coagulation will be more rapid in the warm chamber.

11. Take 10 c.c. of fresh blood-serum and saturate it with magnesian sulphate by adding the salt in powder. **Paraglobulin** will be precipitated, since like other globulins it is insoluble in a saturated solution of a neutral salt; filter (before filtering the precipitate may be allowed to settle and most of the fluid removed by decantation), wash on the filter with a saturated solution of the salt, then add 5 c.c. water to the precipitate, the salt solution clinging to the precipitate will be diluted and the paraglobulin dissolved. It does not coagulate spontaneously.
12. Add a small quantity of paraglobulin solution to hydrocele fluid. Coagulation will result.
13. Treat 10 c.c. of hydrocele or pericardial fluid with sodium chloride to saturation, and proceed as in § 11; a precipitate of **fibrinogen** will be obtained, its solution does not coagulate spontaneously.
14. Add to 1 c.c. of a strong solution of fibrinogen an equal volume of blood-serum, and set aside; coagulation will take place.
15. Take 2 c.c. of plasma (§ 9), add to it 16 c.c. of



water, and determine that the mixture coagulates very slowly.

Take another 2 c.c. of plasma, and add to it 16 c.c. of an aqueous solution of prepared **fibrin ferment**<sup>1</sup>; coagulation will quickly take place.

16. Dilute serum ten-fold with water and with it observe the following general reactions of **proteids**. (If sufficient serum is not obtainable, take the white of an egg, cut through the membranes in several places with scissors, add 50 vols. of water, beat up well, filter through flannel and then through filtering paper.)

a. Xanthoproteic reaction. Take a little of the

<sup>1</sup> The student may prepare fibrin ferment in one of the following ways:

- a. Let blood run into 10 times its volume of water, tilt it upside down once or twice so that the fluids are well mixed, and let it stand for a day. Filter through muslin and squeeze the excess of fluid out of the clot, chop it up and wash with water until all or nearly all of the colouring substance is removed, place it in 10 times its bulk of 8 p.c. NaCl solution, and warm for one to two days; filter; the filtrate contains fibrin ferment.
- b. Add alcohol in abundance to serum until no further precipitation takes place, filter, and dry the residue over a water-bath at 35° C.; place the residue in a bottle containing an excess of absolute alcohol, and leave for a month; at the end of this time decant as much alcohol as possible, evaporate the rest at a low temperature (under 40° C.); extract the residue with 200 times its volume of water, and filter. The alcohol will have coagulated the greater part of the paraglobulin and albumin, etc., and so rendered them insoluble in water, hence the aqueous filtrate will contain little else than fibrin ferment, the more so the longer the alcohol has been acting; the comparative absence of proteids should be tested by the reactions given in § 16.

dilute serum, add a few drops of nitric acid, and boil. The white precipitate of proteid material at first formed becomes yellow and partially dissolves, forming a yellow solution. If the quantity of proteids present is small, the yellow solution only will be obtained. Place the test-tube in a stream of water from a tap to cool and when cold add ammonia; the yellow is turned to orange.

- b. To another small quantity of the serum add a few drops of Millon's re-agent<sup>1</sup>. A precipitate will be formed which turns pinkish on boiling; if the amount of the proteids present be small, no distinct precipitate will be formed but the fluid will turn pink on boiling.
- c. Add a drop of cupric sulphate solution to an excess of sodium hydrate. To the blue solution so formed add a little dilute serum, the fluid will become violet (cp. reaction of peptone, Lesson XVI.). The violet colour becomes deeper on warming.
- d. Add strong spirit, a precipitate is formed (peptone in solution is precipitated with difficulty).
- e. Add excess of acetic acid and a few drops of a strong solution of potassium ferrocyanide, a precipitate is formed (peptone is not thus precipitated).

17. With the diluted serum or white of egg observe

<sup>1</sup> Cp. Appendix.

in the following manner the coagulation of **albumin** and **globulin** by heat. The white of egg contains a small quantity only of globulin. Place a test-tube containing 10 c.c. of the fluid in a water-bath at about 50° C. and heat the bath not too slowly up to about 80° C. Note on a thermometer placed in the bath or in the test-tube the temperature at which coagulation begins (fluid slightly milky) and that at which coagulation is complete (precipitate with clear fluid). If the fluid is very slowly heated the coagulate may be small owing to the formation of alkali albuminate (cp. Lesson IX. § 16); to avoid this the serum should be carefully neutralized with acetic acid before dilution.

18. Add 2 c.c. of serum drop by drop to about 100 c.c. of water in a glass beaker. A faint cloudy precipitate of **globulin**, which is insoluble in water, will be seen (cp. Lesson IX. § 14).

### DEMONSTRATIONS.

1. Coagulation of blood over mercury without access of air.
2. Fluidity of blood in living blood-vessels.
3. Coagulation of blood within the vessels during life on foreign bodies or in injured blood-vessels.

## LESSON IV.

### HYALINE CARTILAGE.

1. Snip off a piece of the free edge of any of the thin cartilages projecting from the sternum or shoulder-girdle of a freshly killed young newt<sup>1</sup>. Gently scrape away with a scalpel any tissue attached to it. Mount it in normal saline solution<sup>2</sup> and with a high power note that
  - a. The **matrix** is studded at tolerably regular intervals with **cartilage cells** or **corpuscles**.
  - b. Each corpuscle consists of a spherical or ovoid mass of **cell-substance**, in which lies a relatively large **nucleus**. Both of these are fairly clear and transparent, though usually showing a variable number of fine granules.
  - c. Most of the cells entirely fill up the cavities in which they lie.

<sup>1</sup> Instead of this, sections of the head of the humerus or femur of any young animal may be made.

<sup>2</sup> i. e. .6 p.c. aqueous solution of sodium chloride. In this and the following Lessons whenever a tissue is directed to be mounted in normal saline solution it is to be understood that if either fresh aqueous humour, or fresh blood-serum is obtainable, it is to be preferred.

- d.* Along the cut edge some cavities from which the cells have fallen out may generally be seen.
- e.* Except at the free edge, the cells are two or more layers deep.
- f.* The matrix is hyaline or faintly granular, and is comparatively (cp. *infra* §§ 4, 7) in small quantity.

If the newts are not quite young the cartilage will vary from the above in the quantity of matrix, the shape and arrangement of the cells, and in the cells possessing small fat globules and often two nuclei.

2. Irrigate the piece with acetic acid 1 p.c. The following changes will be seen as the irrigation proceeds:
  - a.* The nucleus becomes much more granular and distinct.
  - b.* Granules appear also in the cell-substance, and more or less hide the nucleus.
  - c.* The cell-substance becomes transparent owing to the disappearance of the granules.
  - d.* The cell-substance shrinks from the matrix, and presents a granular-looking finely serrated border. Note the space thus formed between the cell and the matrix.
3. Place a small piece in gold chloride solution .5 p.c. for about half an hour, (until it is of a light yellow colour,) then *wash well with water*, and place it in a vessel containing water just acidu-

lated with acetic acid; leave it exposed to the light. In one to two days, when it has become a red-purple colour, mount it in glycerine.

Observe the cell-substance well coloured, and hardly at all shrunken, the nuclei deeply coloured and having a sharp outline, the matrix coloured very slightly.

4. Take a piece of rib cartilage from a recently killed adult animal and with a razor cut thin transverse sections<sup>1</sup> and transfer them with a camel-hair brush to a watch-glass containing normal salt solution. Mount one section in normal salt solution and another in osmic acid 1 p.c.; in the former observe under a high power, that
  - a. The cells frequently shew signs of partial degeneration, containing fat globules which may be nearly as large as the cell; these are very highly refractive and so have a very distinct outline.
  - b. In places the matrix may be fibrillated, and in places semi-opaque owing to calcareous deposit; irrigate with 1 p.c. hydrochloric acid, the calcareous deposit is dissolved, but the fibrillation is not affected (it differs thus from the fibrillation of white fibrous connective tissue, cp. Lesson v. § 2 b).
  - c. Indications of primary and secondary capsules may be seen (cp. § 6).

<sup>1</sup> The sections may be cut with a freezing microtome, cf. Appendix.

5. Examine the section which has been mounted in osmic acid; the fat globules are stained a deep brown-black, the cell-substance, the nuclei and the matrix are but slightly stained.
6. Prepare transverse sections of costal cartilage which has been preserved in picric acid (cp. Lesson I F. § 3), the sections may be made as in § 4 or the tissue may be imbedded (cf. Lesson VI. § 1). Stain the sections by placing them in a 2 p.c. solution of picrocarmine for 5 to 10 minutes or in a very dilute solution (e.g. .02 p.c.) for a day; if placed in the strong solution they should be looked at now and then to see that they are not overstained. Wash the sections with water and mount them in glycerine.

Observe that the cells are arranged in groups (each group having arisen by division from a single cartilage cell), note the outline of the thin layer of newer cartilage (capsule) around each cell, sometimes the whole of the cells in a group may be seen to be also surrounded by a thin layer just marked off from the rest of the matrix. Towards the outside of the cartilage the cells become flattened in a direction parallel with the surface. This specimen should be preserved<sup>1</sup> for examination later (Lesson v. B. § 7).

<sup>1</sup> With a small brush or glass rod spread a fairly fluid solution of Canada balsam over the edges of the cover-slip and the adjoining part of the glass slide; the balsam will dry in a day or so and the specimen can be moved about without fear of the cover-slip being displaced. If the glycerine in which the section is mounted does not stretch to the edges of the cover-slip the balsam will run underneath it and

7. Take a piece of cartilage from the head of a cuttle fish which has been preserved in picric acid and subsequently in alcohol. Cut sections, imbedding if necessary (Lesson VI. § 1). Select a thin section and immerse it in hæmatoxylin for a few minutes watching that it does not stain too deeply, place it in a watch-glass containing spirit to remove the colouring matter simply adhering to the tissue (if it is too deeply stained, place it in a little 1 p.c. acetic acid and when it is sufficiently decolourised, replace it in the spirit), then mount it in glycerine. Observe
- a. The groups of cartilage cells.
  - b. The marked **processes** proceeding from the cells of one group, running towards and anastomosing with the processes from the cells of other groups.
8. Take a small piece of the ear of a freshly killed mouse or young rat, remove the skin and scrape away the tissue surrounding the ear-cartilage. Mount the cartilage in normal saline solution. Observe that the cavities of the cells, generally polygonal in form, are separated by very narrow partitions of matrix. From many of the cavities the corpuscles have disappeared altogether, leaving simply a honeycombed matrix. This

probably spoil the section; on the other hand if the glycerine spreads beyond the cover-slip the balsam will not stick to the glass, in this case it is generally less trouble to remount the specimen than to wipe away the superfluous glycerine. The Student should make one or two trials to find out the proper quantity of glycerine to take with the cover-slips he uses.



form of cartilage is frequently called "parenchymatous."

If it is desired to preserve this specimen or one of newt's cartilage (§ 1), place it in 75 p.c. alcohol for about half-an-hour, stain with hæmatoxylin (cp. § 7) and mount in glycerine.

## LESSON V.

### CONNECTIVE TISSUE.

#### A. CONNECTIVE-TISSUE FIBRES.

##### 1. **Elastic Fibres.**

- a.* Tease out in water a morsel of ligamentum nuchæ. It is almost entirely made up of rather large branching, and anastomosing fibres having distinct outlines, and curling at their ends.
- b.* Irrigate with acetic acid (1 to 5 p.c.); the fibres are unaffected.

##### 2. **White Fibres.**

- a.* Place on a slide a small piece of a thin tendon, e.g. from a digit of a frog or from the tail of a mouse (cp. B. § 3) and, keeping it in position at one end with a needle, separate as completely as possible the fibres from one another at the other end by passing a needle through it in the direction of its length. If the unteased end of the tendon is so thick that it would tilt up the cover slip, separate with needles a small outer portion

and tease this out as above; the tissue should be kept moist with normal salt solution but no more than is necessary should be added. Place a small drop of salt solution on a cover slip and let this fall gently on the tissue.

Observe the wavy bundles of fibrillæ; the outlines of the fibrillæ are not very distinct but they may be seen to run parallel to one another; owing to their small size and to the cementing substance between them special preparation is required to isolate the individual fibrillæ completely.

- b. Irrigate with acetic acid (1 to 5 p.c.). The fibrillæ disappear, and the whole tissue swells up into a transparent gelatinous mass, in which hardly anything can be distinguished except a few elastic fibres similar in general characters to those of A. 1, but much finer.
- c. Pull up with fine forceps the thin connective tissue lying between the muscles of the thigh of a rabbit or frog, cut off with scissors a small piece and tearing it as little as possible spread it out on a slide with the aid of needles, breathing on it if necessary to prevent it from drying. Mount as in § *a* or press a dry cover-slip gently on the film and allow saline solution to run under the cover-slip; thus the film is kept extended.  
It is chiefly composed of wavy bundles of fibrillæ similar to those seen in (*b*); the bundles are of various sizes and run across one another

in all directions. Some small elastic fibres running singly will also be seen, their outlines are more distinct than those of the bundles of white fibres; they sometimes branch and sometimes anastomose where they cross one another. Where the film is well stretched the elastic fibres run for the most part quite straight, elsewhere they are curled at their ends and have a more or less sinuous course. If there is any doubt as to which fibres are elastic, irrigate with acetic acid, cp. (b).

*d.* To make evident the corpuscles, take a rather large piece of the film and let the edges partially dry so that it may stick to the glass slide; add a drop or two of a strong solution of Spiller's purple in water or in 30 p.c. alcohol, in a few minutes wash away the excess of the purple with water from a pipette, and mount in water.

## B. CONNECTIVE-TISSUE CORPUSCLES.

1. Take a piece of the thin expansion of a tadpole's tail preserved in chromic acid .2 p.c. Gently break up a piece in glycerine. Where the hexagonal cells of the epidermis have broken away, the homogeneous matrix may be seen, imbedded in which are many blood-vessels and a number of stellate cells.

The larger dark stellate cells are pigment-cells, the smaller stellate cells are **connective-tissue corpuscles**, each of which consists of a nucleus and a branched protoplasmic body. Their pro-

cesses divide much, but irregularly, and communicate with the processes of other cells.

2. Take a frog, of which the brain and spinal cord have been destroyed<sup>1</sup>, squeeze the side of the head gently to make the eye bulge out, then slice boldly at the edge of the cornea; if it is not completely separated, take up the edge with forceps, and cut through the cornea with scissors at its junction with the sclerotic; in doing this remember that the success of the preparation greatly depends upon the cornea being placed in gold chloride without having been dragged or pulled about; any blood which may be on the cornea should be removed by placing it in a watch-glass containing normal saline solution and very gently brushing it with a camel-hair brush. Put it in gold chloride .5 p.c. solution for twenty to forty minutes, *wash well with water*, transfer to water just acidulated with acetic acid, and expose to light<sup>2</sup>. When the cornea has become of a red- or blue-violet colour, put it on a slide with glycerine, and brush or scrape both surfaces to remove the epithelium, then mount in glycerine and examine it under a high power. Where the hexagonal surface epithelium has been removed, there will be seen stained connective-tissue corpuscles, with numerous fine branching processes which anastomose with the similar processes of neighbouring cells.

<sup>1</sup> See Appendix.

<sup>2</sup> Probably it will not be stained until the following day. By the tartaric acid method (cp. Appendix) the staining is quicker.

This preparation should be preserved to shew the nerves of the cornea (cp. Less. x. C. § 2).

3. Break off the tip of the tail of a mouse or young rat just killed, and pull out from the stump a bundle of fine tendons. Gently stretch this over a glass slide from edge to edge, and hold it in this position till the edges are dry, putting a drop of normal saline solution in the middle only; the fibres are thus kept extended. Cover with a cover-slip. On examination the bundles of wavy fibrillæ will be seen, but no corpuscles. Slowly irrigate with acetic acid 1 p.c., *watching the bundles the while* under a high power. Between the bundles of fibrillæ will be seen rows of cells. Note in each the round or oval nucleus, the rectangular outline of the cell, and the granular cell-substance. Indications of flange-like lateral processes may be seen as lines running along the cells in the direction of the tendon. After the acetic acid has been added for some little time the cell-substance becomes very indistinct, and between the swollen bundles scarcely anything is seen but rows of elongated irregularly shaped nuclei. (cp. Action of acetic acid on cartilage cells, Lesson IV. § 2.)
4. Cut transverse sections of a tendon which has been placed in 30 p.c. alcohol for a few hours and preserved in 75 p.c. alcohol, imbedding (cp. Less. VI. § 1) if satisfactory sections cannot otherwise be obtained: mount in dilute glycerine. Observe

- a. The fasciculi separated from one another by a small amount of connective tissue.
  - b. In each fasciculus the thin branched tendon cells between the bundles of fibrillæ of the tendon. The processes of neighbouring cells not infrequently join.
  
- 5. Dissect back a piece of skin of a recently killed young and fasting rat or other animal, and into the subcutaneous tissue attached to this inject a .5 p.c. solution of gold chloride with a Pravatz syringe, until the fluid begins to exude. Let this stay for a few minutes, and before the swelling produced subsides snip off with a sharp pair of scissors one or two pieces as thin as possible, and place them in a watch-glass containing three parts of water and one part of formic acid 1.06 sp. gr. When the pieces are well coloured, which will probably be in two or three hours, shake them gently in a glass containing distilled water, then mount in the manner given in A. § 2 c, but in acid glycerine<sup>1</sup>. The preparation will improve in a day or two. Observe
  - a. The leucocytes scattered about between the bundle of fibres; the fibrous bundles will be more or less swollen up by the formic acid, and so not offer sharp outlines.
  - b. Connective-tissue corpuscles rather larger than the leucocytes, and having processes

<sup>1</sup> Glycerine containing 1 p.c. formic acid.

which, in some cases, are seen to be connected with the processes of other similar cells. (cp. B. §§ 1, 2.)

- c. Larger, more rectangular cells, generally without evident processes, with oval nuclei, lying over the bundles of fibrous tissue often in rows or patches; on a side view these appear as thin long cells.

This preparation should be preserved for the observation of fat tissue (D. § 5).

6. Snip off a small piece of the jelly-like subcutaneous tissue in a foetal or new-born mammal<sup>1</sup>, and mount as in A. § 2, c.

Note the pale granular cells of various shapes, some not unlike those seen in B. § 1. To make the cells and their nuclei more distinct stain with Spiller's purple in the manner given in A. § 2 (d), or irrigate with dilute acetic acid watching closely the early changes produced.

This may also serve to shew the development of fat-cells (D. § 6).

7. Note in the section of costal cartilage prepared in Lesson IV. § 6 the connective tissue layer outside and closely attached to it forming the perichondrium; in places sections of tendons running into the cartilage will probably be seen.

<sup>1</sup> An animal just killed serves best, but one preserved in picric acid or Müller's fluid will answer the purpose; if it is desired to observe the forming fat-cells the animal must not have been transferred to alcohol stronger than 50 %.



## C. PIGMENT-CELLS.

Pin out on a frog-board one of the webs between the toes of the frog used in B. § 2, and observe first under a low and then under a high power. There will be seen large corpuscles loaded with dark pigment, and possessing numerous branched processes. In some places the pigmented cells will appear as round dots, the processes in this case having been retracted. Every intermediate stage between these two states may be observed by watching from time to time.

## E. FAT-CELLS.

1. Cut out a small piece of the omentum, from a part containing comparatively little fat. Spread it out on a slide and mount it in normal saline solution. Observe
  - a. Under a low power, the groups of highly refractive fat-cells.
  - b. Under a high power, the variable size of the fat cells, the apparent absence of a nucleus, the connective tissue passing between and over the cells.
2. Place a similar piece of omentum in osmic acid 1 p.c. for about half-an-hour, wash with water and mount in dilute glycerine. Observe that the fat-cells are stained a deep brown-black (cp. Less. IV. § 5). If the tissue after washing be placed in alcohol (preferably 75 p.c.) the tint will become much darker.

3. Take a small piece of omentum, which has been kept for some time in alcohol, and place it in hæmatoxylin until it has become well stained. Wash it with spirit, place it on a glass slide, and tease it out if it is too thick. Remove as much of the spirit as possible with blotting-paper. Cover the tissue with a mixture of creosote (1 part) and turpentine (4 parts), and let it remain until it is completely transparent, changing the fluid and gently warming if necessary. Remove the excess of turpentine, cover the tissue with a drop of Canada balsam, and put on a cover-slip.

Observe the groups of cells from which the fat has been thus removed. Note the shrunken outlines of the cells, the marked membrane, and the presence in each cell of a deeply stained nucleus. A small amount of protoplasm, also stained, may be seen as in § 4.

4. In the gold chloride preparation of sub-cutaneous tissue made above (B. § 5), observe

The network of capillaries in a small collection of fat-cells.

The large, flat, connective-tissue corpuscles (B. § 5, *e*) in greater quantities near the groups. When the fat-cell group is spindle-shaped, these may often be seen proceeding in rows from the ends.

In some fat-cells a nucleus and a small amount of protoplasm surrounding the fat may be seen. Do not mistake a deposit of crystals in the fat for a nucleus.

5. Take a piece of tissue as in B. § 6 but just outside the border of a small fatty clump visible to the eye.

Observe the transitional forms between the granular cells containing a few small fat globules and cells in which hardly anything but fat is to be seen.

## LESSON VI.

### MODIFICATION OF CONNECTIVE TISSUE AND HYALINE CARTILAGE.

#### A. TRANSITION TO FIBRO-CARTILAGE.

1. Take a piece of intervertebral cartilage<sup>1</sup>, which has been treated with chromic or picric acid and subsequently with alcohol, and imbed it in the following manner. At one end of a small oblong block of paraffin *B*<sup>2</sup> scoop out a small hole; with blotting-paper remove the excess of alcohol from the piece of cartilage and place it in the hole so that the plane of the uppermost surface is at right angles with the plane of the vertebral face. Pour over it a little of the paraffin mixture heated so as to be just melted; remove any bubbles that may be present and keep the tissue in its proper position by means of a heated needle; when the whole is thoroughly solid pare down the paraffin

<sup>1</sup> Cut off from one face of a vertebra of a rabbit a thin slice about 1 mm. thick, leaving the intervertebral cartilage in connection with it; divide the more or less circular piece so obtained into four parts, and treat with chromic or picric acid to dissolve the salts (cp. Appendix).

<sup>2</sup> Cp. Appendix.

to the surface of the cartilage, at the same time bevelling the edges. In cutting the sections, cover the tissue and the blade of the razor with spirit (for convenience from a wash-bottle) and remove the sections by means of a camel-hair brush from the razor to a watch-glass. With the platinum "lifter" transfer them to hæmatoxylin and treat as in § 7, Lesson IV.

It is to be remembered that if the chromic acid<sup>1</sup> has not been completely removed from the tissue the staining will be very imperfect; in this case the sections should be placed in a little  $\text{Na}_2\text{CO}_3$  1 p.c. for a few minutes and then washed with water before staining. Observe in the sections

- a. The softened bone passing into
- b. The thin layer of hyaline cartilage; outside this
- c. The arrangement of the cartilage cells in rows, and the concomitant appearance of fibres in the matrix, this gradually but rapidly merging into
- d. Fibro-cartilage consisting of bundles of white fibrous tissue and of rather large cells arranged in rows between the fibrous bands; these cells are like the cells of hyaline cartilage and each has a thin hyaline capsule around it.
- e. Towards the outer part of the cartilage, the capsules and cells become smaller and more

<sup>1</sup> Müller's fluid, potassium bichromate and ammonium bichromate, must similarly be completely removed from tissues which are to be stained.

elongated, the capsules disappear, and so the fibro-cartilage merges into

*f.* Connective tissue.

The fibro-cartilage does not form one continuous band connecting the vertebra, but passes in parallel bundles, between and at right angles to which are tendinous bundles which thus will be seen in cross sections; the cartilage cells may in some bundles also be absent.

2. Prepare through the junction of the round ligament and head of the femur in a young animal a section parallel to the direction of the fibres. If the tissue has been treated with picric acid, stain the section in picrocarmine; if in chromic acid, with hæmatoxylin. Observe as the tendon approaches the cartilage the transition of the flat rectangular branched cells of the tendon to oval fuller cells with round nuclei. Note the gradual disappearance of distinct fibres and their replacement by a hyaline matrix, the cells at the same time becoming scattered. Thus the tendon passes into fibro-cartilage, and fibro-cartilage into hyaline-cartilage.

## B. . TRANSITION TO ELASTIC CARTILAGE.

Dissect out the arytenoid cartilage of a sheep, preserved in alcohol, and cut out a small piece of the tissue immediately above the hyaline cartilage, and together with a little of the hyaline cartilage itself. Imbed, and cut sec-

tions, including the hyaline cartilage and the tissue above it. Stain with picrocarmine and mount in glycerine. Observe

- a.* That at the upper surface of the hyaline cartilage, the matrix becomes granular, and the granules are arranged in rows, which then often have less the appearance of rows of granules than of granular fibres; these may be traced into ordinary fine elastic fibres, which increasing in quantity, form
- b.* The elastic cartilage in which the cells stained red with carmine are similar to those of hyaline cartilage; they have thin clear outlines around them, the capsules, and these are surrounded by a meshwork of elastic fibres stained yellow with picric acid lying in a varying quantity of matrix. This meshwork may have not so much the appearance of distinct elastic fibres, as of a system of thick bars, recalling in general feature parenchymatous cartilage.
- c.* Above (*b*) ordinary loose connective tissue, note the transition of the elastic cartilage into this by the elongation of the cells and the breaking up of the elastic fibres into loose bundles and the appearance in those of white fibrous tissue staining red.

## LESSON VII.

### BONE, OSSIFICATION, TEETH.

#### A. STRUCTURE OF BONE.

1. Examine under a low power prepared transverse sections<sup>1</sup> through the shaft of a long bone. Most of the smaller spaces (i.e. Haversian canals, lacunæ, canaliculi) will be filled with air or debris and will therefore appear dark. Observe
  - a. The central cavity surrounded by a small amount of spongy bone which is arranged in a network with rather large irregular spaces (Haversian spaces); externally the spongy bone passes into the compact bone: note the transition from the Haversian spaces to the Haversian canals.
  - b. In the compact bone the Haversian systems, each consisting of a **Haversian canal** surrounded by concentric **lamellæ** which are chiefly marked off from one another by the **lacunæ** which lie between them.

<sup>1</sup> It is simplest to buy these sections.





5. Prepare transverse sections through the shaft of a long bone which has been decalcified<sup>1</sup>. Stain with picocarmine (cp. Lesson IV. § 6). Wash with water and mount in glycerine. Observe that
- a. Each lacuna is occupied by a cell or **bone corpuscle**.
  - b. The canaliculi are scarcely visible.
  - c. The Haversian canals and spaces are occupied by cells, connective-tissue fibres and blood-vessels (red blood corpuscles if present will be stained yellow).
  - d. If the tissue of the central cavity has not fallen out of the section, it will be seen to consist of fatty tissue.
  - e. The periosteum is closely attached to the outside of the bone; it consists externally chiefly of white fibres, internally largely of small elastic fibres some of which may be seen to run into the bony matrix.
6. Take a bone (e.g. the parietal) which has been decalcified by nitric or hydrochloric acid, well washed with water and preserved in spirit; remove the periosteum, tear off from the surface thin strips of the bone matrix and mount them with the inner side uppermost in water. Under a high power note the **perforating fibres** projecting from the surface and the apertures through which similar fibres have passed.

<sup>1</sup> Cp. Appendix for methods of decalcification.

Examine carefully the thinnest part of the strip (containing fewest lamellæ) for the fine *decussating fibres* of the matrix; add acetic acid, both the perforating and decussating fibres swell up and become indistinct or lost to view.

## B. OSSIFICATION.

1. Cut a longitudinal section through the head of the femur of a newly-born rabbit, cat, etc. The femur should have been divided longitudinally into four parts, and treated with picric or chromic acid to harden it and to dissolve the salts. Stain the sections with eosin or picrocarmine, wash with water, place first in dilute and then in strong spirit, clear with creosote and turpentine<sup>1</sup> (or turpentine alone) and mount in Canada balsam (cp. Lesson IV. footnote). Observe
  - a. The normal hyaline cartilage.
  - b. The cartilage cells arranged in rows. Note that many of the cells in section are triangular, the broad side of one lying above the angle of the other; this indicates an

<sup>1</sup> The creosote and turpentine is used since it dissolves any paraffin that may be attached to the tissue (from the imbedding), makes the tissue transparent, and mixes well with the Canada balsam; carbolic acid may be used instead of the creosote, it is cheaper but does not dissolve the paraffin mixture quite so readily. Clove oil causes less shrinking in many tissues than creosote and turpentine, but it is much dearer than either of them and does not dissolve the paraffin mixture in the cold. The clearing of the sections takes place more readily and certainly if they are placed for a few minutes in absolute alcohol before they are placed in the clearing agent.

origin of two cells from one by oblique division.

- c.* A layer of cells much larger than the previous ones, with clear cell-substance (in the specimen probably shrunken) and a distinct nucleus; they are also arranged in rows and have only a small amount of matrix between them.
  - d.* The large irregular cavities below this layer surrounded by bone matrix, and containing many **osteoblasts**, cells very similar in appearance to white blood corpuscles, but larger, most of them are in contact with the bone matrix. In the centre of some of the cavities may also be seen a blood-vessel with surrounding connective tissue.
  - e.* **Osteoclasts** may be seen here and there in contact with the bone matrix; they are large multinuclear cells, and where they touch the bone are often striated at right angles to the surface.
2. Imbed a piece of the shaft of any long bone<sup>1</sup> of a foetal mammal that has been preserved in picric or chromic acid, any remaining salts in the bone may be extracted by placing it for a day in spirit containing .5 p.c. nitric acid. Cut transverse

<sup>1</sup> Instead of these, sections may be made of the lower jaw of a foetal mammal; the developing sub-maxillary bone shews admirably the osteoblasts and osteoclasts but the section is confusing to beginners owing to the number of other tissues present.

sections and stain them with picrocarmine, and mount in glycerine or Canada balsam. Observe

- a. The **periosteum** consisting externally of coarse connective tissue, internally of fine connective tissue with numerous cells.
- b. The **trabeculæ** of the bone matrix, externally these give off numerous small projections into the inner layer of the periosteum.
- c. The **osteoblasts** forming a layer on the outer surface of the bone matrix; some will also be seen on the trabeculæ throughout the section; note the fine connective tissue and the blood vessels in the trabecular spaces. Many of the osteoblasts especially in the external layer are elongated and their smaller ends appear to run into the matrix.
- d. Some osteoclasts as in § 1, e. may be seen.

### C. STRUCTURE OF TEETH.

1. Examine under a low power longitudinal sections of teeth prepared in the same manner as bone in B. Observe the **dentine** surrounding the pulp cavity, the **cement** or **crusta petrosa** covering the dentine of the fangs, and the **enamel** covering the dentine of the crown. Note the general arrangement of the dentinal tubules.
2. Examine under a high power the same section, and study in detail

a. The **Dentine**.

- a.* In the matrix, apparently homogeneous, are numerous dentinal tubules which run in a wavy course from the pulp-cavity outwards. These, dividing as they go, and giving off many anastomosing lateral branches, finally end either in loops or in small irregular cavities, the so-called interglobular spaces, on the surface of the dentine.
- β.* In some places the dentinal tubules are cut transversely. Here the central dark spot indicates the space formerly occupied by the dentinal fibre, the ring round this is the dentinal sheath.

b. The **Cement** or **Crusta Petrosa**.

- a.* This differs little from bone, but Haversian canals are generally absent.
- β.* The canaliculi of the lacunæ, next to the inter-globular spaces, open into these, thus bringing the dentinal fibres into connection with the bone-corpuscles.
- γ.* Where the cement is massive, wavy 'contour' lines may be seen, indicating the successive deposits.

c. The **Enamel**.

The striated enamel fibres or prisms are arranged in sets, perpendicular to the surface of the dentine. In mounted specimens the indications of the separate fibres are generally not well marked, but are visible at

places. The line of junction of the enamel and dentine is generally very conspicuous, in consequence of a change of level in the specimen, the dentine having been ground thinner than the harder enamel. The enamel is frequently split or cracked.

3. Examine prepared transverse sections of Teeth, taken at different heights, and compare with the above.

## LESSON VIII.

### STRUCTURE OF CONTRACTILE TISSUES.

1. Cut off the head of a frog which has just been killed, remove carefully the lower jaw and upon the mucous membrane of the roof of the mouth pour a little osmic acid 1 p.c. (before doing this a small piece of the membrane may be cut out to serve for § 2). Cover up the preparation and leave it for about half an hour<sup>1</sup> then scrape a small area of the mucous membrane and tease out the flakes so obtained in water or in dilute glycerine, putting a small piece of paper underneath the cover-slip to avoid pressure. Examine under a high power. Groups of **ciliated cells** intermingled with mucous (goblet) cells will be seen; neglect the latter, note in the former
  - a. The shape of the cell varies, it often branches irregularly at its attached end.

<sup>1</sup> Or the mucous membrane after treatment with osmic acid as above may be gently washed with water to get rid of the fumes of the acid, removed with forceps and scissors, pinned out with hedgehog quills and placed in osmic acid 1 p.c. for 1 to 24 hours as convenient. The oesophagus and the mucous membrane of the floor of the mouth which also have cilia may be similarly treated.



- b.* The free surface is densely studded with cilia. The cilia seen in profile appear to form a row, but when a cell is seen in face, they are foreshortened into mere dots and are seen to be spread over the whole surface.
  - c.* The nucleus is not very obvious but may, with its nucleolus, be made out; the cell-substance is somewhat granular but has a non-granular, hyaline border just below the cilia.
2. Cut out a small piece of the same membrane in a recently killed frog, place it on a slide, from a portion of it scrape off the epithelium and tease out the scrapings in normal salt solution; with this mount the unteased portion of membrane putting a fragment of paper underneath the cover-slip. Note
- a.* In the unteased portion the shimmering appearance caused by the movements of the cilia.
  - b.* The movements of the cilia in the isolated cells or clumps of cells. Observe carefully the cilia which are moving slowly; it may be seen that the down-stroke (contraction) takes place more quickly than the return (relaxation); there is no perceptible pause between the two movements.
  - c.* The results of ciliary action. Granules and blood-corpuscles are driven along; detached

cells may also be seen carried about by the action of their own cilia.

- d.* The contracted, almost globular form of the cells which have been set free.
3. Tear off the smallest possible strip of a **frog's muscle**, which has been kept extended and preserved in alcohol, and tease it out as finely as possible in dilute glycerine. Note
- a.* The varying size of the fibres.
  - b.* The striation of the fibres: alternate dim and bright cross-bands passing through the whole thickness of the fibre.
  - c.* The breaking up of the fibre into fibrillæ, the latter also striated. Try to obtain as fine fibrillæ as possible. The fibres sometimes split transversely into discs; this is usually the case when the muscle has been preserved in picric acid; the surfaces of the discs appear dotted.
4. Cut through the skin of the front of the thigh of the frog used in § 2, note the sartorius muscle running somewhat obliquely across the thigh from top to bottom, seize with forceps the connective tissue lying along its inner border in the upper part of the thigh and tear this back to the knee, remove similarly the connective tissue at its outer border, thus the tissue covering the muscle will also be removed. Take up with fine forceps a few fibres at one end of the muscle, and

gently pull them out to the opposite end. Lay them on a glass slide, and separate them a little in the centre, place a bristle across them and press gently: remove the bristle, put on a coverslip and let a drop of normal saline solution run underneath it (cp. method, Lesson V. A. § 2 *a, c*). Where the bristle was pressed on a fibre the muscular substance will be seen in many cases to be broken across leaving its delicate transparent sheath, the sarcolemma, stretching across the gap; an indication of the sarcolemma as a fine line bulging out from the muscle substance may also be seen where a fibre is bent.

5. Irrigate with acetic acid .5 p. c. and observe
  - a.* The fibres at first become cloudy and semi-opaque.
  - b.* The precipitate causing this cloudiness is after a while dissolved, and the fibres become more transparent than normally.
  - c.* The nuclei of the fibres come into view scattered throughout the muscle substance; they are elongated in the direction of the fibre: lines of granules proceeding from their ends may usually be seen.
  
6. Cut through the skin in the mid ventral line in a small frog, lift up the flap of skin on one side over the middle of the sternum, a thin band of muscle will be seen running from the skin downwards towards the lower part of the sternum.

Cut through the skin above and below the muscle, and tear away the connective tissue around it, then, keeping it stretched, pour a little 1 p.c. osmic acid over it. In a minute or so the muscle will be fixed; with fine forceps tear away carefully from the muscle any connective tissue that can be seen on its surface and cut it out being careful to cut the upper end as close as possible to the skin; place it in osmic acid for a few minutes, wash with water, mount it in either dilute glycerine or after treatment with alcohol etc. in Canada balsam, keeping that surface uppermost which was next the body. (This specimen should be preserved for examination later, Lesson x. C. § 1.)

Observe at the upper end of the muscle the endings of the muscular fibres, these will probably be covered by a good deal of connective tissue, but the rounded or conical ends of the muscle-substance of the fibres and the continuation of the sarcolemma into the connective tissue (tendon) will be seen.

7. Remove with as little injury as possible one of the thin muscles from the leg of **Hydrophilus**<sup>1</sup>, tease it out a little without adding fluid and mount as in § 4. The fibres will for a brief period be seen in a normal condition. In many, the alternate dim and bright striæ will be very dis-

<sup>1</sup> If not obtainable, take the large common water-beetle (*Dytiscus marginalis*), or failing that a cockroach or a fly.

tinct; in others the transverse markings will be more or less obscured by an appearance of longitudinal fibrillation. Occasionally fibres are met with, having only a confused granular aspect. If the preparation has been successfully made, waves of contraction may, at times, be seen to travel along the fibres.

Observe in the fibres with distinct transverse striation, that,

- a. The dim band has a faint longitudinal striation, as if made up of small rods.
- b. The bright band shews a dotted line running across its centre, thus dividing it into two parts. If the preparation be good, and a high magnifying power be used, this may be seen to consist of two rows of dots.
- c. The usually round nuclei, imbedded in a granular mass of protoplasm; the whole forms a band or rod running a variable distance in the substance of the fibre (cp. § 5 c).

8. Imbed a small piece of **mammalian muscle**, hardened in chromic acid .5 p.c., and cut transverse sections, stain with hæmatoxylin, and mount in glycerine. Observe

- a. The connective tissue (perimysium) around the bundles of fibres and around the whole muscle, from this runs a small amount of connective tissue (endomysium) between the muscle fibres.

- b.* The cut ends of the fibres are finely dotted corresponding with the fibrillæ; sometimes the cut ends are divided into larger polygonal areas (areas of Cohnheim), this appearance is produced by the hardening agent.
- c.* The nuclei lying just beneath the sarcolemma, few or none being imbedded in the muscular substance of the fibres (cp. § 5 *c*).
- d.* In some part of the section, the fibre-fragments may be turned over and lie lengthways; in these the striation and tendency to break into fibrillæ may be noticed as in frog's muscle.
9. Remove the peritoneum from a part of the intestine of a recently killed mammal, and tear off with fine forceps a strip as thin as possible of the longitudinal muscular coat. Place this in potassium bichromate .1 p.c. or in 30 p.c. alcohol for two days, wash with water, stain with picrocarmine, wash and tease out in dilute glycerine.
- Note
- a.* The isolated fibre-cells. These are long, and, when not broken off in the preparation, fusiform masses of hyaline or faintly granular protoplasm. They appear very much thinner when seen in one direction than in another; that is to say, they are much flattened. In the middle of each fibre an elongated nucleus will be seen stained deeply. In the neighbourhood of the nucleus, especially at its

ends, granules are more abundant in the protoplasm.

- b. The arrangement of the fibre-cells in bands and sheets: the fibres may frequently be seen projecting like a palisade from the torn end of a band.

10. Take a small strip of unstriated muscle as in § 9 and tease it out in salt solution.

The sheets and bands of the tissue are fairly transparent, the individual fibre cells are scarcely visible. Add acetic acid, .1 to .5 p.c., the cells become for a short time somewhat more obvious, and the nuclei very distinct, often showing one or two nucleoli.

11. Make longitudinal vertical sections of the muscular coats of the cardiac end of a cat's or dog's stomach. The tissue should have been pinned out, placed in Müller's fluid for two to four weeks and then treated with alcohol. Stain with carmine or hæmatoxylin and mount<sup>1</sup>. Observe

The cells are arranged in bundles, probably this will be distinct in the inner (circular) coat only, the outer (longitudinal) coat being cut parallel to the direction of its bundles. Note the nuclei of the cells in the inner coat; these will be seen in some only of the cells and will appear as largish deeply stained cen-

<sup>1</sup> When it is indifferent whether a tissue be mounted in glycerine or in Canada Balsam, neither is mentioned; if balsam is used, of course the tissue must be treated with creosote, etc. (cp. p. 75).

tral spots. (This section should be preserved for examination later, Less. XVI. A. § 3.)

The reduction of nitrate of silver by the cement substance between the muscle cells will be seen later, Less. XII. C. § 4.

12. Tease out thoroughly a small portion of **cardiac muscle** preserved in potassium bichromate<sup>1</sup>. Note that

- a. The striation is less distinct than in skeletal muscle.
- b. No sarcolemma is present.
- c. At short intervals along the fibres are not very distinct transverse bands of hyaline cement substance, this joins together the muscle cells of which the fibres are composed. At about the centre of each muscle cell is a nucleus. (The nuclei will become more evident if the tissue be stained with alum-hæmatoxylin or picrocarmine.)
- d. The isolated muscle cells may frequently be seen to have a short obliquely running process; in the fibres the processes of the cells are joined to other similar processes by a little cement substance, forming thus the anastomoses of the fibres.

<sup>1</sup> Good preparations can also be obtained by the following method (Ranvier). Thin sections in the direction of the fibres are cut from a fresh heart, placed in chromic acid .02 p.c. for one day, then washed *well* with water, placed in picrocarmine for one or more days, washed and mounted in acid glycerine.



## DEMONSTRATIONS.

1. The structure of a living muscular fibre of an Insect as seen under a high power.
2. The appearances of muscular fibre under polarised light.

## LESSON IX.

### PROPERTIES OF CONTRACTILE TISSUE.

#### 1. **Constant Current.**

Destroy the brain and spinal cord of a frog and make a longitudinal incision through the skin of the back of the thigh. With fine-pointed scissors cut through the connective tissue between the large semi-membranosus muscle and the small biceps: the former lies on the inside of the thigh, the latter is seen along the outer and lower border of the semi-membranosus. The sciatic nerve and the femoral artery will come into view; at about the upper third of the thigh, the artery will be seen to give off two small transverse branches running, in the position of the frog, over the nerve; from this point down to the knee, isolate the nerve by tearing away with a "seeker" the connective tissue around it; if the tissue is resistant it is better to lift up the nerve with a seeker and to cut through the connective tissue with fine scissors. Be careful not to pinch the nerve with the forceps, nor to put more strain upon it than is absolutely necessary, and further not to puncture the artery.

Take a pair of electrodes which have their platinum points exposed on one side only, and connect them with two Daniell's cells arranged in series (i.e. with the copper of one joined by means of a wire with the zinc of the other) interposing a key<sup>1</sup> to short circuit the current. Instead of Daniell's cells any other cells of corresponding strength may be used.

The key being shut<sup>2</sup>, place the electrodes under the nerve so that the nerve, and the nerve only, touches the platinum points, then open the key, so as to allow the current to pass into the nerve, and after a few seconds shut it again. A movement in the leg caused by contractions in the muscles to which the nerve is distributed, will be seen when the key is either opened or shut, or on both occasions. Save in exceptional cases, *there is no movement during the passage of the current through the nerve, but only when the current is thrown into or shut off from it* (the current being supposed to be tolerably constant). Do not repeat this experiment more than once or twice on the same nerve, lest it be too much exhausted for the succeeding observations.

<sup>1</sup> Cp. Appendix for a description of the instruments and for the methods of using them.

<sup>2</sup> For convenience of description the terms 'shut' and 'open' which apply to a Du Bois Reymond key are used, but if the student remembers that to shut the key is to let the current pass through it, and to open the key is to break the current passing through it, he will have no difficulty in using a Morse or other key in the place of that of Du Bois Reymond.

## 2. **Single Induction Shocks.**

Now connect a Daniell's cell with the top screws of the primary coil interposing a key to break the current, connect the electrodes with the secondary coil of a Du Bois Reymond's induction machine<sup>1</sup>, place the marker of the secondary coil at 10 on the scale, and, the frog's leg being at rest, shut and open the key several times.

At each shutting and opening of the key, i. e. at each momentary induced current, a single sharp movement of the leg will take place. The 'single induction shock' causes a *single contraction* or *spasm* of the muscles of the leg. If the nerve slips off the electrodes during the movements, be careful not to pinch it in replacing it.

If good contractions are not obtained with the secondary coil at 10, push it up gradually over the primary coil, one division at a time.

3. Shut and open the key as rapidly as you can, for a few seconds. The contraction of the muscle taking longer time to develop than the induced current, each contraction will take place before the preceding has disappeared, and the leg will remain rigidly contracted, or nearly so, as long as the breaking and making of the primary current is kept up. In other words, *tetanus* is produced. This is however more easily brought about as follows.

<sup>1</sup> Cp. Appendix.

#### 4. **Interrupted Current.**

Introduce into the secondary circuit a key to short circuit the current, and remove the wires of the Daniell's cell from the screws at the top of the primary coil to those at the base<sup>1</sup>. The machine should work in such a way that immediately the key in the primary circuit is put down the hammer is at once thrown into oscillations (as indicated by its noise). The key in the secondary circuit being open, shut the primary key. Immediately that the sound of the hammer is heard, the leg is thrust out straight by the tetanic contractions of the muscle, and remains so as long as the current continues to be thus made and broken. Open the primary key; at once the limb becomes flaccid and quiet. The 'interrupted current' should not be applied for more than a few seconds.

#### 5. **Chemical Stimulation.**

Expose the heart (cp. Less. II. A. § 1), and bleed the frog by cutting across the aorta. Cut through the tissue above the sciatic nerve up to a quarter of an inch beyond the end of the urostyle, and there cut it across, with scissors and seeker isolate the nerve up to the cut. Let the extreme end of the nerve dip into a saturated solution of sodium chloride; watch the leg.

In a variable time twitchings of the toes will be seen, and after a while these will increase in

<sup>1</sup> Cp. Appendix.

vigour and will extend over the limb until it becomes almost as rigid as in § 4.

#### 6. **Mechanical Stimulation.**

Cut off the part of the nerve which has been dipping in the salt solution; the chemical stimulus being thus removed, the leg will become flaccid again.

Pinch the remaining nerve sharply with a pair of forceps several times. At each pinch the muscles of the leg will contract. The pinching kills or injures the part of the nerve pinched; hence it is necessary to begin at the cut end, and work down towards the muscle.

The gastrocnemius muscle of this leg may be used for § 13, *b*.

#### 7. **Curve of Single Muscular Contraction.**

Place the frog on a glass or porcelain plate; on the left side cut through the skin at the back of the thigh and carry the skin cut half way up the back. Lift up the urostyle and cut through the muscles attached to its lower half, then holding it well up cut through the muscles attached to its upper half: it is as well to avoid cutting the 10th nerve which runs along the under surface of the muscles. Note the 7th, 8th, 9th and 10th nerves which unite to form the sciatic; with strong scissors cut away the urostyle and cut through the vertebral column above the 7th nerve: lift up the lower piece of the vertebral column and without injury to the

nerves of the left side cut away the rest of the tissue attached to it. Then lifting up the piece of bone without stretching the nerves, cut through with scissors the tissue attached to them, follow the nerves on to the sciatic and cut through the tissue above and attached to the sciatic including the branches given off by the nerve; isolate thus the sciatic down to the knee. Letting the nerve rest on the muscles of the thigh, cut through the skin of the upper part of the thigh; seize the flap of skin with stout forceps, and tear it away from the leg as far as the foot. Placing the nerve on the muscle below the knee cut away the muscles attached to the lower half of the femur, and with a strong pair of scissors cut through the middle of the femur. Cut through the lower (Achilles) tendon of the gastrocnemius muscle close to its attachment to the foot, and seizing the tendon with forceps tear the gastrocnemius away from the other muscles up to its attachment with the femur; cut through the tibia and fibula just below the femur. The preparation so obtained is called a **nerve-muscle preparation**<sup>1</sup>.

Now pass a hook through the Achilles tendon, clamp the femur, and taking up the preparation

<sup>1</sup> When two nerve-muscle preparations are to be obtained from one frog, the lower part of the vertebral column should be bisected longitudinally. It is perhaps somewhat better not to bleed the frog before commencing the dissection, but in this case considerable skill and patience are required to avoid cutting small vessels and so covering the nerve with blood.

by the clamp and by the piece of vertebral column, arrange the preparation in the moist chamber as in Fig. 2 Appendix. Load the lever with 15 or 20 grammes, and bring the lever to mark on the revolving cylinder.

Connect the electrodes with the induction machine arranged for single induction shocks as in § 2.

Set the cylinder rotating at its swiftest speed and with the marker of the secondary coil at 10 take a tracing of the contraction caused by a break induction shock (the make shock is prevented from reaching the nerve by shutting the key in the secondary coil, arranged for short circuiting, before that in the primary is shut; on opening in the reverse order the breaking shock passes into the nerve). Observe the rapid but steady rise to a maximum, passing almost immediately into a similar but rather less rapid fall; the later stages of the fall are distinctly less rapid than the earlier ones.

Take another tracing over the previous one with the secondary coil at 5; the height of the contraction is somewhat greater.

8. Place the secondary coil at 25, the key in the secondary circuit being open, shut that in the primary circuit and after a short interval open it; if no contraction follows shift the secondary coil nearer and nearer the primary, stimulating at each shift.

Since the induction shock caused by breaking



the current is stronger than that caused by making it, a contraction will be obtained earlier on opening than on shutting the primary key.

9. **Tetanus.**

Now arrange the induction machine for an interrupted current (§ 4), the secondary coil being at 15 or 20 to begin with.

With the cylinder moving slowly, take a tracing of a tetanic contraction of a muscle, stimulating for not more than three or four seconds.

Observe the rise to a maximum at first rapid but afterwards more and more slow, the maintenance of the maximum during the application of the current, and the fall, at first rapid but afterwards more slow, after the removal of the current. Watch during the tetanus the muscle itself as well as the curve.

10. Connect one wire from the Daniell's cell with one of the top screws of the primary coil, and the other to the binding screw of the oscillating rod (cp. Appendix), connect a wire with the other top screw of the primary coil and bending the wire place its opposite end in the mercury cup. A key for short-circuiting should be kept in the secondary coil. Allow the full length of the rod to oscillate, open the key in the secondary circuit and take a tracing of the muscular contractions; then take successive tracings with the rod shorter and shorter.

Observe the gradual fusing of a series of single contraction curves into the curve of tetanus.

11. Load the muscle with 50 grammes, allowing the lever to write on the stationary cylinder. Note the elasticity of the muscle. The weight when applied stretches the muscle to a certain extent, but when raised so as not to drag on the muscle, the latter returns, at once to almost, and eventually to quite, its former length. Stimulate with an interrupted current (coil say at 20). Note the amount of contraction. Repeat this with 100, and then with 200 grammes, using in each case the same strength of current for the same time, moving the cylinder with the hand so as to expose a fresh black surface for each observation.

Observe that with medium weights the work done (the product of the weight into the height) is greater than with very light or very heavy weights.

Observe also that the muscle gradually becomes exhausted, i.e. the contractions caused by the same stimulus gradually become less and less.

12. Probably the preparation will be nearly exhausted; take as in § 7 a tracing of a single muscular contraction, and note the difference in the form of the curve; the rise is less rapid, the fall more gradual, the muscle may take some time to regain its original length.

### 13. Reaction of Muscle.

- a. Remove the muscle from the moist chamber, place it on a *clean* glass slide, and apply the electrodes, connected with the induction

machine arranged for an interrupted current, *directly* to the muscle.

Observe that the current applied directly to the muscle produces the same effect as when applied indirectly through the nerve. To completely eliminate the effect of stimulating the nerves urari should be given to a frog the brain of which has been destroyed. Tetanize the muscle with currents of increasing strength until it is completely exhausted, pushing the secondary coil right up over the primary.

Cut the muscle across in half, with a *quite clean* scalpel, and press on one section a piece of faintly blue, on the other a piece of neutral litmus paper. Both will be turned red where they come in contact with the muscle.

- b. Dissect out the gastrocnemius from the leg used in §§ 1—6, and place it for five minutes in normal saline solution heated to 50° C. Observe that it has become contracted and opaque, i. e. *rigor mortis* has set in. Cut the muscle across, and test with litmus paper as in *a*. The muscle will be distinctly acid, even more so than the tetanized muscle in *a*.
- c. Take a fresh, living gastrocnemius from a frog just killed, cut it across as in *a* and *b*, and test the sections with neutral litmus paper. The muscle will be found neutral or faintly alkaline.

14. **Myosin.**

Strip off the muscles from a rabbit or other animal and chop them up as finely as possible, place them in a large jar filled with water and stir; in about a quarter of an hour place a piece of muslin over the top of the jar and pour off the water; fill up the jar again with water and let it stand for an hour, then pour off the water and refill the jar as before. When this has been repeated once or twice the greater part of the substances soluble in water will have been removed; it is best however to let the muscle stay in water for a day adding a little thymol or salicylic acid to prevent putrefaction. The filtrate from a small quantity of muscle which has been in an equal bulk of water for an hour should give no proteid reaction if the muscle has previously been thoroughly washed.

Collect the muscle on linen, squeeze out the water, grind it up with clean sand and add 5 times its bulk of 10 p.c. ammonium or sodium chloride, and stirring occasionally place it aside for an hour or so (naturally if it is left longer more myosin will be obtained). Filter through muslin,<sup>1</sup> through linen, and then through coarse filter paper. A somewhat viscid fluid is obtained; pour this into a tall vessel containing about a litre of water and observe the precipitate of **myosin** which takes place (or the

<sup>1</sup> The residue may be again treated with 10 p.c. ammonium chloride.

fluid as it filters may be allowed to drop into water).

After a short time decant or draw off with a pipette as much fluid as possible, shake up the rest and pour about 5 c.c. with the myosin suspended in it into each of three test-tubes.

- a. Add drop by drop a strong (e.g. 20 p.c.) salt solution, the precipitate soon dissolves; then place it in a water bath at about 50° C. with a thermometer and heat; at about 57° C. the fluid becomes milky (or a precipitate is formed) owing to the coagulation of the myosin.
- b. Add powdered salt, the precipitate soon dissolves, but when the fluid is saturated with salt is reprecipitated (the precipitate may be in the form of fibrous-looking clumps).
- c. Dissolve the suspended precipitate in salt solution, and test for proteids, e.g. with Xanthoproteic reaction (cp. Less. III. § 16 (a)).

Myosin belongs to the class of globulins; it will have been seen that it is insoluble in water and in saturated neutral salt solutions, soluble in not too dilute solution of neutral salts, its solution coagulating on boiling (cp. also Less. III. §§ 11, 13, 17, 18).

#### 15. **Syntonin or Acid Albumin.**

Treat a portion of muscle washed as in § 14 with ten to twenty times its bulk of HCl .1 p.c. and place in the warm chamber at about 40° C,

frequently shaking. After 3 or 4 hours most of the myosin of the muscle will have been converted into **syntonin** or **acid-albumin**, and dissolved. Syntonin may be prepared in a similar way from white of egg or from serum.

Filter and carefully neutralize the filtrate with a weak solution of sodium carbonate (1 c.c. of HCl ·1 p.c. requires about 1·5 c.c. of  $\text{Na}_2\text{CO}_3$  ·1 p.c. to neutralize it), a copious bulky precipitate of **syntonin** takes place; if too much alkaline salt is added the syntonin will be converted into alkali albuminate and redissolved (cp. § 16). Filter and wash the precipitate once on the filter with water, then break through the filter paper and wash the precipitate into a beaker with water. The syntonin is thus obtained suspended in water. Place 2 c.c. in each of 2 test-tubes.

- a. Add a little HCl ·1 p.c., the precipitate at once dissolves and is not precipitated on boiling; cool under a tap, and test for proteids e.g. with acetic acid and potassium ferrocyanide (cp. Less. III. § 16).
- b. Boil, cool under a tap, and add a little HCl ·1 p.c.; the precipitate suspended in the water has been coagulated by boiling and is no longer soluble in dilute acids.

## 16. **Alkali Albuminate.**

Treat a little washed muscle as in § 15 but with  $\text{NaHO}$  ·1 p.c. instead of with HCl. On neutralizing a precipitate of **alkali albuminate** will be

obtained like that of syntonin; if too much acid is added the precipitate will be converted into acid-albumin and re-dissolved. Take in separate test-tubes a little of the precipitate suspended in water.

- a.* Add a little  $\text{NaHO}$  .1 p.c. the precipitate at once dissolves and is not precipitated by boiling; with the proteid tests a reaction is obtained.
- b.* Boil, cool under a tap and add a little  $\text{NaHO}$  .1 p.c., the precipitate suspended in water has been coagulated by boiling and is no longer soluble in dilute alkalis.
- c.* Add a little  $\text{NaHO}$  .1 p.c. and a little sodium phosphate, with a drop of litmus solution; add drop by drop dilute  $\text{HCl}$ : on neutralizing no precipitate takes place, add a little more acid a precipitate is obtained, if still more is added the precipitate is re-dissolved.

It will have been seen that proteids in solution (except peptone) on warming with dilute acids or alkalis give rise to acid albumin or alkali albuminate respectively, these substances do not coagulate on boiling and so differ from albumin and globulin, and are insoluble in water and so differ from peptone (cp. Less. XVI. C. § 5).

### DEMONSTRATIONS.

1. The electric currents of resting muscle removed from the body (demarcation currents)

2. The negative variation of the currents of the muscle during a contraction (action currents)
3. The rheoscopic frog
4. Action of heat and cold on the single muscular contraction
5. Action of veratrin on the single muscular contraction
6. Curve of elasticity of muscle
7. Measurement of latent period of contraction of muscle by means of pendulum myograph.



## LESSON X.

### STRUCTURE OF NERVOUS TISSUES.

#### A. SPINAL NERVES.

1. Cut off about one-third of an inch of a small perfectly fresh nerve (e. g. a branch of the sciatic of a frog), and place it on a glass slide *without any fluid*. Fixing one end by pressing on it with the blunt end of a scalpel, pass a needle through the other end in the direction of the nerve fibres, and so spread it out into the shape of a fan; add a drop of normal saline solution, and cover with the cover-slip. Observe
  - a. The **medullated nerve-fibres** of variable size.
  - b. In each fibre the double contour, due to the **medullary sheath** or white substance of Schwann.
  - c. The **primitive sheath**; this is seen with difficulty except at points where the medullary sheath has been displaced in mounting.
  - d. The connective tissue (endoneurium) running amongst and round the nerve-fibres.

- e.* Drops and fragments of the medullary sheath, extending from the cut ends of the fibres and shewing a double contour.

Some non-medullated nerve-fibres will also be seen (cp. B).

2. Cut off a similar piece of nerve and treat it in the same way, but instead of adding a normal solution, add a drop of chloroform, and irrigate with chloroform as evaporation goes on. In the middle of the nerve-fibre the pale granular **axis cylinder** will be seen running through the swollen and partially dissolved medullary sheath.
3. Take another piece of fresh nerve, and place it in a small quantity of osmic acid 1 p.c. for ten minutes, covering it up to prevent evaporation. Remove it to a slide, and separate a small bundle of fibres, putting the rest back in osmic acid; isolate the fibres as much as possible, add a drop of water, and put on a cover-slip. If it is desired to preserve the specimen the nerve should be washed with water before teasing and mounted in dilute glycerine. Select a nerve fibre which is isolated for a considerable part of its length, and observe
  - a.* The medullary sheath, stained black with osmic acid.
  - b.* The **nodes of Ranvier**. These will be seen as short but distinct breaks in the medullary sheath; with Zeiss obj. D. oc. 2 they

occur usually at intervals of about twice the diameter of the field, varying considerably, however, in different nerves. The axis cylinder may be seen continuing across the nodes.

- c. The **nuclei** of the primitive sheath; one to each internodal nerve portion situated about halfway between two nodes, and appearing as a small transparent elongated body projecting usually into the medulla.

The nuclei of the primitive sheath may be stained by placing a piece of the nerve, after treatment with osmic acid, in Frey's carmine for two or more days. In such a preparation, the cells of the fine connective tissue around the nerve fibres will also be well seen.

4. Stain with carmine a short piece of a rather thick nerve which has been preserved in ammonium bichromate 2 p.c. (cp. Less. I. F. § 4 and footnote p. 69). Imbed, and cut thin transverse sections, treat these with creosote and turpentine (cp. p. 75 footnote) and mount in Canada balsam. Observe
  - a. The cut ends of the nerve-fibres varying in diameter, and in each
  - b. The section of the stained axis cylinder surrounded by
  - c. A transparent ring indicating the former position of the medullary sheath, which has been dissolved or made transparent in the

process of mounting. If the nerve has been kept long in ammonium bichromate the medulla will shew an indistinct network stained yellow.

- d.* The primitive sheath as a limiting circle.
- e.* The arrangement of the fibres in bundles. The perineurium around each bundle continuous with the endoneurium between the fibres.

## B. SYMPATHETIC NERVES.

1. Cut out from the fresh spleen of a large animal (e.g. ox) a small piece of one of the large sympathetic nerves running alongside the blood-vessels. Remove the connective-tissue sheath, and tease out the nerve carefully in normal saline solution. Note
  - a.* The scanty medullated nerve fibres.
  - b.* The **non-medullated** nerve fibres constituting the bulk of the nerves: they are fairly transparent, and often fibrillated, some give off fibrillae. Add acetic acid to bring out more distinctly the small elongated nuclei which lie on them at short intervals.
2. Take a small piece of the sympathetic nerve from the neck of a freshly-killed rabbit, place it in osmic acid 1 p.c. for five or ten minutes, wash and stain with strong Frey's carmine or with picrocarmine. Tease out in dilute glycerine.

Numerous small medullated fibres will be seen mingled with the non-medullated fibres. Compare the size of the medullated fibres here and in the sciatic nerve (A, § 1).

### C. PERIPHERAL COURSE OF NERVES.

1. In the specimen prepared Less. VIII. § 6: observe
  - a. Under a low power, the nerve running across the lower part of the muscle and sending off fibres or bundles of fibres at intervals and so spreading out over it.
  - b. Under a high power, that where the lateral bundles (especially the smaller ones) are given off, one or more of the nerve fibres divide into two fibres, the division taking place at a node. Trace a small bundle of nerve fibres, the nodes are very close together. Each nerve fibre apparently ends abruptly over a muscle fibre; in this specimen it can only be traced as far as the blackened medulla extends.
2. Make a gold chloride preparation of the cornea<sup>1</sup>

<sup>1</sup> The mesentery of the frog may be taken instead of the cornea, but it is more difficult to obtain a good preparation. The mesentery of the lower coil of the small intestine is pinned out with the intestine, and placed in gold chloride .5 p.c. for about half-an-hour, it is then well washed, the intestine cut away, and the mesentery exposed to light in acidulated water. The larger nerve bundles, containing a few medullated fibres, accompany the larger arteries and form coarse and fine plexuses of non-medullated fibres as in the cornea, but there are many more nuclei, even very small fibres having nuclei on their course; varicose fibrils like those of the cornea will probably not be seen.

of a frog as in Less. v. B. § 2 and mount in glycerine a sector of it, including its junction with the sclerotic. Note

- a. The small separate bundles of nerve fibres entering the cornea at its periphery; the medullated fibres on account of their medulla are more deeply stained than the non-medullated.
- b. Trace as far as possible the course of one of the nerve bundles; the medulla soon disappears, the fibres, still showing nuclei at intervals, join with the fibres from other bundles to form a coarse plexus; from this proceeds a plexus of smaller bands which have few nuclei; finally from this plexus run very fine varicose non-nucleated nerve-fibrils in straight lines across the cornea (these fine fibrils may also be seen forming part of the finer bands of the plexus).

#### D. SPINAL GANGLIA.

1. Take a mammal's spinal ganglion (e.g. a dorsal spinal ganglion of a cat or dog) which has been preserved in ammonium bichromate 2 p. c. about three weeks, and subsequently in spirit. Prepare sections passing through the trunk of the nerve, the ganglion, and the anterior and posterior roots of the nerve. Stain with hæmatoxylin or carmine, clear (cp. p. 75) and mount in Canada balsam.

Observe with a low power that

- a. The fibres of the anterior root mix with those of the posterior root below the ganglion.
- b. Most of the ganglion cells lie outside the fibres of the posterior root; some lie in rows between the fibres.

2. Observe with a high power

- a. In the **ganglion cells** the rather granular cell-substance, containing a large spherical nucleus which often has one or more distinct nucleoli.
- b. The many **nuclei of the capsule** of each ganglion cell.
- c. The stained axis cylinders of the nerve fibres. (The medulla may show an irregular network of substance hardened by the ammonium bichromate.)
- d. The nerve fibres coiled amongst the cells, and fibres running more or less transversely from the lateral mass of cells to the central bundle of nerve fibres.

3. Destroy the brain and spinal cord of a frog and cut off its head. Remove the lower jaw and divide the skull in two down the middle line. Tear away the mucous membrane covering the roof of the mouth; the inner and lower part of the eye will be laid bare. Just behind the eye is a depression; from this two or three small filaments, the branches of the fifth nerve, will be

seen issuing. Cut through the bone from the middle line to the place where the nerves issue, turn the piece of bone forward, and gently scrape out the brain.

A filament (the fifth nerve) will then be seen going towards the branches spoken of above. Between the two is a slight enlargement, the Gasserian ganglion, surrounded by tough connective tissue and by connective tissue attached to the bone. Cut away this tissue and excise the ganglion.

Tease it out a little in .25 p. c. osmic acid<sup>1</sup>, leave it in the acid for about half-an-hour, then wash, and place it in strong Frey's carmine for a day; wash, and tease out in glycerine, during the teasing examine from time to time under a low power and throw away the fragments which consist of connective tissue only.

Instead of the Gasserian ganglion a spinal ganglion from a frog or mouse may be taken. In the frog the spinal ganglia are surrounded by a chalky mass; when this is removed the ganglion can be seen as a greyish semi-transparent bulging on the nerve, the 7th, 8th, 9th are easiest to obtain.

Examine carefully the more isolated cells; here and there one will be seen with its cell substance prolonged into a process; from most of the cells the process will probably have been torn away in teasing.

<sup>1</sup> Or it may be placed in potassium bichromate .2 p. c. for two or three days and then teased out.



## E. SYMPATHETIC GANGLIA.

Place a sympathetic ganglion e.g. the superior cervical sympathetic ganglion of a rabbit in 1 p.c. osmic acid for a day. Wash it with water and leave it in water for some hours. Transfer to 50 p.c. spirit for an hour, then to strong spirit for a week. Cut longitudinal sections and observe

- a. The large number of nerve-cells of various sizes.
- b. The small number of medullated nerves compared with the spinal ganglion (D § 2 a).
- c. The small size of nearly all the medullated nerves (cp. D § 2 d), when these are in bundles they are usually at the periphery of the ganglion.
- d. The bundles of non-medullated nerve-fibres at the ends of the ganglion; the distinctness with which these are seen will of course vary in different sections.

*Dissection of Sympathetic Ganglia in the Frog.* Lay open the abdomen of a recently killed frog, pick up the intestine and cut through the mesentery just above the kidneys; pulling up one kidney, cut through the peritoneum along its edge, and turn over the kidney to the opposite side of the body. Gently stretch the spinal nerves away from the spinal column, a row of small nerve fibres will be seen running transversely from the spinal nerves (one from each nerve) to the chain of pigmented, semi-transparent sympathetic ganglia which will be seen lying over the spinal column.

## F. CELLS OF SPINAL CORD.

Cut transverse sections of the spinal cord of a large mammal (e. g. calf or ox) which has been hardened in ammonium bichromate 2 p. c. and subsequently treated with alcohol. Stain with carmine or dilute picrocarmine (it is better still to stain the small piece of cord before cutting sections by placing it in strong Frey's carmine for several days); clear and mount in balsam. Note

- a.* In the white substance the cut ends of the nerve-fibres differing very greatly in size (cp. with A § 4).
- b.* The small amount of connective tissue (neuroglia) between the nerve fibres; this is finely dotted (transverse sections of semi-elastic fibrils), and is more abundant near the grey substance.
- c.* In the grey substance of the anterior cornu, the large multipolar nerve-cells each with a large nucleus and distinct nucleolus. Select a conspicuous cell and note that the processes run off in all directions; many of them will be seen to branch and these branches to branch again and so on (protoplasmic processes); from some of the cells a rather large process which does not branch may be seen to run outwards through the white substance (axis cylinder process).
- d.* In the grey substance of the posterior cornu, the much smaller usually fusiform nerve-cells with branching processes at either end.

## DEMONSTRATIONS.

1. Preparations to shew the method of ending of motor nerves in muscle.
2. Preparation to shew the nerve-cells of the plexus of Auerbach in the intestine.
3. Mounted transverse section of a nerve which has been treated with osmic acid.

NOTE TO D § 3. *Isolation of nerve cells.* The ganglion may be placed in osmic acid 1 p. c. for half an hour, washed in water, placed in a mixture of equal parts of glycerine and strong acetic acid for three or four days, and then teased out.

## LESSON XI.

### GENERAL PROPERTIES OF NERVOUS TISSUE. AUTOMATIC ACTIONS.

#### A. REFLEX ACTION.

1. Place on its belly a frog, which has been previously deprived of its brain<sup>1</sup> by the demonstrator. Observe that its hind-limbs are drawn up under the body; but that it differs from the normal frog in the following respects.
  - a. Its head is depressed, instead of being erect.
  - b. Its fore-limbs are spread out, or flexed, instead of being held nearly vertical; thus the angle which the body makes with the table is diminished.

<sup>1</sup> This is done by cutting across the spinal cord just below the skull and thoroughly destroying the brain with a seeker; in order to ensure the complete removal of the medulla oblongata, it is advisable to destroy the parts a short distance down the spinal canal. The frog should be left in a moist place for a day. Instead of this the frog may be chloroformed the skull cut open and the brain removed; or the upper jaw with the anterior part of the skull may be cut off with strong scissors and the medulla removed with forceps, with this method the reflex action is often weak owing to the considerable loss of blood.

- c. There are no respiratory movements, either of the nostrils, or of the throat.
2. Gently pull out one of the hind-limbs, until it becomes quite straight, and then let it go. It will be immediately drawn up into its old position under the body. If this experiment be made soon after the operation of removing the brain, or if much blood has been lost, the leg may be drawn up slowly instead of sharply.
  3. Gently tickle one flank with a feather or a blunt needle; a contraction of the flank muscles of that side will be observed.
  4. Pinch the same spot rather sharply with a pair of forceps; the leg of the same side will be first extended, and then drawn up and swept over the flank, the movement tending to thrust away the points of the forceps.
  5. Pinch with the forceps the skin round the anus; both legs will be drawn up and thrust out again; the movement tending as before to sweep away the points of the forceps.  
 Leave the animal alone for five minutes and watch it carefully: if no disturbing circumstances are brought to bear on it, it will remain perfectly motionless.
  6. Place the animal on its back; it will make no effort to regain its normal position, *i.e.* all sense of equilibrium has been lost.

7. Pass a hook through the lower jaw, and fasten it to the cross-bar of a stand so that the body can be raised up and down. The hind-limbs, after a few movements of flexion and extension, will remain pendant and motionless.
8. Gently pinch the tip of one of the toes of either leg; that leg will immediately be drawn up.
9. Take two glasses, fill one with dilute sulphuric acid (.1 p.c.) and the other with water: lower the frog until the tip of one of the toes just touches the dilute sulphuric acid. In a short time the foot will be withdrawn. At once let the foot dip into the second glass containing water, in order to wash away the acid. Measure with a rapidly beating metronome, the time between the moment when the toe comes into contact with the acid and the moment when it is withdrawn. Make, at intervals of a few minutes, three such observations, and take the mean of the three.
10. Cut a small piece of blotting-paper one or two mms. square, moisten it with strong acetic acid, and place it on the flank of the animal. The leg of the same side will be speedily drawn up and swept over the flank as if to remove the piece of paper.
11. Place similar pieces of paper dipped in acetic acid on different parts of the body; different movements will be witnessed in consequence;

all however tending to remove the irritating substance.

12. Wash off all the acid from the frog, and when it has become perfectly quiet, place it in a basin of water; it will sink to the bottom (unless the lungs be accidentally much distended with air), and no movements of any kind will be witnessed.

*Observe that all the movements produced in the foregoing observations, although complicated, co-ordinated, and purposeful in character, are partial, and only by accident bring about locomotion. However stimulated, the animal never springs or leaps forward.*

*In order that the same frog may serve for observations on the lymph-hearts, B. I. § 1 should be performed here.*

13. Make a small cut through the skin of the back<sup>1</sup>, and with a fine glass tube inject one drop of a 1 p.c. solution of strychnia. In a few minutes the slightest stimulus applied to any part of the animal will produce violent tetanic spasms of the whole body. A preliminary stage of increased reflex action may also be observed.
14. With a straight seeker or a piece of stout wire destroy the whole of the spinal cord. Observe that the spasms immediately cease.

<sup>1</sup> Immediately underneath the skin of the back of the frog is the dorsal lymphatic sac, and any fluid placed in this rapidly makes its way into the blood.

15. Repeat any of the above observations (§ 2—13).  
No reflex actions will now be produced.

## B. AUTOMATIC ACTION.

### I. **The Lymph-Hearts.**

1. Placing the animal on its belly watch the movements of the posterior lymph-hearts. They may be seen beating on either side of the extremity of the urostyle, in a depression between that bone and the hip-joint. The contractions are generally visible through the skin, but become more evident if the skin be removed, care being taken not to injure the lymph-hearts themselves.
2. Observe that after destruction of the posterior part of the spinal cord the lymph-hearts cease to beat.

### II. **The Heart.**

1. Lay the frog on its back, make a median incision through the skin, and from the middle of this make transverse incisions. Raising up the end of the sternum with a pair of forceps, cut it through a little above the end so as to avoid cutting the epigastric vein. Then again lifting up the sternum cut it through longitudinally with a strong pair of scissors; pin back each part of the sternum, cutting through such muscles as may be necessary; the heart will



be seen in the thin membranous pericardium beating with considerable regularity and force. Pinching up the pericardium with a fine pair of forceps, cut it away from the surface of the heart then tilt up the apex of the ventricle; a small band of connective tissue will be observed passing from the posterior surface of the ventricle to the adjoining wall of the pericardium. Seizing this band with the forceps, divide it between the forceps and the pericardial wall. Lift up the apex of the ventricle, by means of this band, and with a sharp pair of scissors cut through the aortæ, the superior venæ cavæ, the inferior vena cava, and the surrounding tissue. Take care not to injure the sinus venosus. Place the heart in a watch-glass, moistening it when necessary with normal saline solution. The beats will either not be interrupted at all or for a very short time.

In cold weather the heart may stop on being removed from the body, but if the heart be warmed by putting the watch-glass containing it in the palm of the hand, the beats will be resumed.

2. Lifting up the apex of the ventricle by means of the same band as before, cut through the ventricle with a sharp pair of scissors at its upper third. The lower two-thirds of the ventricle will remain motionless without any spontaneous beat; the upper third and the auricles will continue to beat with regularity.

3. By means of a longitudinal incision divide the auricles with the attached portions of ventricle into two lateral halves. Each half will continue to beat.

### III. **Cilia.**

Placing the frog on its back, cut through the lower jaw, in the middle line, and carry the incision down the oesophagus as far as the stomach. Pin back the parts and moisten the mucous membrane, if it is at all dry, with normal saline solution. Place on it, a little below the orbits, a small thin piece of cork. The cork will be seen to be driven by ciliary action down towards the stomach.

## DEMONSTRATIONS.

1. The electric currents of nerves removed from the body (demarcation currents).
2. The negative variation attending a nervous impulse (action current).
3. The effect of a constant current on demarcation currents (electrotonus).
4. The effect of a constant current on the irritability of nerves (electrotonus as affecting irritability).
5. The law of contraction.

6. The phenomena of urari poisoning.
7. The function of the anterior and posterior roots of the spinal nerves.
8. The peristaltic movements of the intestines and of the ureters

## LESSON XII.

### STRUCTURE AND PROPERTIES OF BLOOD- VESSELS.

#### A. THE LARGER ARTERIES.

1. Cut transverse and longitudinal sections of a small piece of the aorta or carotid artery of a dog (or other animal), which has been preserved in potassium bichromate 1 p. c.; stain with picrocarmine. Note
  - a. The thin **inner coat** thrown into longitudinal folds by the contraction of
  - b. The much thicker **middle coat**, consisting of alternating layers of elastic and circularly arranged muscular tissue. Both of these are stained of a yellower tint than the white fibrous tissue. The disposition and relative amount of the elastic and muscular tissue will be found to vary much in different arteries.
  - c. The **external coat** (tunica adventitia), consisting mainly of white fibrous connective

tissue, with some elastic tissue not infrequently arranged in layers, especially at the inner part of the coat. Note the nuclei of the muscle cells (cp. Lesson VIII. § 11).

As a rule in the more peripheral arteries, the middle coat is formed of bundles of muscular fibres separated from one another by a small amount only of connective tissue with elastic fibres.

2. Take the jugular vein from a freshly-killed rabbit, cut it open longitudinally, and pin it out with hedgehog quills with the inner surface uppermost on a thin piece of cork; stream water gently over it for a moment, then pour over it a .2 p. c. solution of nitrate of silver and leave it for five minutes, wash well with distilled water, and expose to light, also in distilled water, until it becomes of a brownish colour: spread it out on a slide with the inner surface uppermost, treat it successively with 50 p. c., 75 p. c., 95 p. c. alcohol, clear and mount it in Canada balsam.

Observe the rather jagged dark lines of the cement substance between the cells; the cells form a continuous layer, are more or less elongated in a longitudinal direction, and are flat; indications of the nuclei of the cells may be seen, and in some places indications also of the fibres of the muscular coat, as transverse or longitudinal markings caused by a deposition of silver in the cement substance between the muscle cells. If the vein has been left too long in the

silver nitrate solution, or exposed too long to light, silver will be deposited in the substance of the cells also.

A vein is here taken as being a somewhat easier preparation for a student than an artery; the main features in either case are the same.

3. Cut open longitudinally a large artery, e.g. carotid of sheep, from a freshly killed animal, and very gently scrape the internal surface. Tease out the material so obtained in normal saline solution.

Observe in surface and profile the cells of the lining **epithelium**, with their elongated nuclei. Probably there will also be seen fragments of the elastic **fenestrated membrane**. Add acetic acid 1 p.c. to distinguish more clearly the elastic from the white fibrous tissue. (The perforations in the fenestrated membrane are rendered more distinct by staining.)

4. Tear off a strip from the inner coat of a medium-sized artery which has been in potassium bichromate .2 p.c. for two to six days; tease it out in the fluid; it will be found to consist almost entirely of **elastic laminae**.

Observe the gradations from an almost homogeneous elastic perforated membrane to a mesh-work of elastic fibres.

## B. THE LARGER VEINS.

1. Cut transverse sections of a fairly large vein, as in A. § 1. Relatively the muscular element will be found to be less (though varying considerably in different veins); the elastic element also to be less, and the white fibrous connective tissue more plentiful.
2. Attempt to make fluid pass along a vein of some large animal in the wrong direction, in order to shew the action of the valves. Cut open the vein and examine the structure and position of the valves.

## C. CAPILLARIES AND SMALL BLOOD-VESSELS.

1. Place on a slide with a drop of glycerine the tail of a tadpole which has been hardened in Muller's fluid or in chromic acid .2 p.c. and subsequently treated with alcohol. Brush off the surface epithelium or if this is unsuccessful break it up into not too small fragments with needles (in doing so try to scrape off the epithelium). The tissue may be previously stained by placing it for a day in dilute picocarmine. Note
  - a. The network of capillaries; in some, blood-corpuscles will probably be seen.
  - b. The nuclei in the walls of the capillaries, especially at the points of bifurcation.
  - c. The branched connective-tissue corpuscles, in places partially surrounding the capillaries,

and constituting the simplest form of a tunica adventitia.

- d.* The connection of some of the processes of the connective-tissue corpuscles with the capillary walls.
2. Remove a small portion of pia mater from a perfectly fresh brain of a chloroformed cat or dog allowed slowly to bleed to death, and spread it out carefully in normal saline solution, washing it gently with the same, and mount. Note
    - a.* The capillaries, with their nuclei bulging into the channels.
    - b.* The small arteries, their scanty external connective-tissue coat or adventitia, and the indications of their muscular coat composed of a single layer of fibres wrapped round the intima.
    - c.* The small veins generally filled with blood-corpuscles, with their muscular coat absent or developed only to a slight degree.
  3. Gently irrigate with acetic acid 1 p. c. Note
    - a.* In the capillaries, the more distinct nuclei.
    - b.* In the small arteries,
      - (*a*) The fusiform cells and nuclei of the adventitia, arranged longitudinally, with elastic fibres.
      - (*β*) The nuclei of the muscular coat arranged transversely. By watching the



earlier stages of the action of acetic acid, the outlines of the muscle fibres, as well as of their nuclei, will be distinctly seen.

- ( $\gamma$ ) The thin inner elastic layer, internal to the muscular fibres, seen as wrinkled longitudinal markings.
- ( $\delta$ ) The oval nuclei of the lining epithelium arranged longitudinally.

c. In the small veins, appearances similar to *b*, consistent with the less development of muscular and elastic tissue.

A piece of fresh pia mater may be stained with aqueous hæmatoxylin to bring out more clearly some points of the above; the following will, however, be found a better method. Place a fresh brain, with the dura mater at least in part removed, in potassium bichromate 1 p. c. for two or three days (or longer), then wash it with water, and place it in 75 p. c. spirit for half an hour to twenty-four as convenient, cut off then a small piece of pia mater, stain with hæmatoxylin, or picrocarmine, and mount. Care should be taken to drag the membrane as little as possible, and to avoid creases.

4. Destroy the brain and spinal cord of a frog, lay bare the heart, cut through the whole length of the muscles of the abdomen a little on one side of the epigastric vein. Cut off the ventricle and cut across the venous sinus (cp. Less. XI. B. II.), sop up with a sponge the blood which

flows out, when the bleeding has ceased take a small glass cannula having a piece of india-rubber tubing over one end and filled with normal salt solution and insert it into the aortic bulb, tie it near or at the branching of the aortæ with a silk thread. Then take a syringe full of normal salt solution, and the tubing being also full of salt solution gently force the nozzle of the syringe into the tubing, being careful that no air-bubbles get in at the same time. Then slowly inject the salt solution: this should be repeated until the fluid issuing from the venous sinus is perfectly clear; sop up the fluid and inject with water, then inject once or twice a .2 p. c. solution of nitrate of silver, sopping up the fluid which issues from the sinus; inject water to wash out the nitrate of silver, place the frog in a basin of water and cut out the intestine; cut through the mesentery at its junction with the intestine and lay open the intestine, brush away its epithelial coat and expose it to light in water or in 30 p. c. alcohol. The outlines of numerous vessels will soon be visible; then cut out a piece, spread it out on a slide with the inner surface uppermost, wash with alcohol of increasing strength, clear and mount in Canada balsam<sup>1</sup>.

<sup>1</sup> If the tissue be left too long before it is mounted the cells as well as the cement substance will become black. From the frog injected as above a piece of the mesentery, or of the lungs, or of the bladder, may be mounted.

Note with a low power the small arteries branching into capillaries and the uniting of the capillaries to form veins which again unite to form larger veins.

Note under a high power the outlines of the flat elongated epithelium cells of the small arteries, of the capillaries and of the small veins; the outlines in the capillaries are more irregular than in the arteries or veins; in the veins the cells are rather broader than in the arteries.

In the small arteries the cementing substance between the cells of the muscular coat (here usually a single layer) will also shew as black transverse lines, the small veins are without these transverse markings.

#### D. CIRCULATION OF BLOOD. INFLAMMATION.

Take a frog with a pale web which a day or two previously has been deprived of its brain by the Demonstrator (cp. p. 116, footnote) and kept in a moist place. With scissors make a small cut through the skin of the back, with a fine pipette introduce underneath the skin one drop of a 1 p.c. solution of urari, leave the frog under a glass jar until it does not move on being pinched; this should be the case in about three-quarters of an hour, if it occurs earlier too much urari has been given and the blood-vessels will be abnormally dilated. Lay the frog on its belly on the frog-board, and tie, not too tightly, a piece of soft cotton round the end of the (e. g.) 3rd and 4th

digits. Stick two pins into the board a little distance from the hole; by twining the cotton round them the web may be stretched out level above the hole (or the toes may simply be pinned out). Surround the web, and cover the leg and body of the frog, with moist blotting-paper. Put a *small* drop of water upon the web, and cover it with a triangular piece of cover-slip, taking care that the glass does not cut into the digits and that no fluid flows over it.

Examine, first with a low and then with a high power. Note

- a. The course of the blood from the arteries to the veins. A slight pulsation may be observed in the larger arteries and sometimes in the smaller ones.
- b. The greater velocity of the blood in the arteries (owing to their smaller size) than in the veins; probably in neither can the individual corpuscles be made out.
- c. The axial and peripheral zones in the arteries and veins; the peripheral zone is small, and under a low power appears free from corpuscles; under a high power one or two white corpuscles may, if the current is not very fast, be seen in the peripheral zone of the arteries; in that of the veins a few white corpuscles and occasionally a red one will be seen moving along comparatively slowly.
- d. The passage of corpuscles usually in single file through the capillaries;

- e.* The elasticity of the red corpuscles, observing the way in which they bend and become deformed, and then regain their normal shape.
6. Remove the cover-slip, and soak up the fluid on the web; touch the middle of the web with the tip of a pointed glass rod that has been dipped in creosote<sup>1</sup>, so as to leave a minute drop on the web, and replace the cover-slip. The early stages of inflammation may be seen. Observe in succession
- a.* The dilatation of the arteries, the much more distinct appearance of the capillaries, and the enlargement of the veins, accompanied by a quickening of the current.
- b.* A slowing of the current, the vessels remaining dilated.
- c.* The white corpuscles increase in number in the peripheral zone of both arteries and veins, in the latter the white corpuscles begin to cling to the sides, at first for a time only, then being carried off, later permanently until the veins have a more or less complete lining of white corpuscles. In the capillaries the white corpuscles and also, though less frequently, the red corpuscles, stick to the capillary walls, partially or completely blocking the way. Later the way becomes com-

<sup>1</sup> Instead of this, olive oil containing 1 to 2 p. c. of croton-oil may be used. In either case the irritant should be washed off if stagnation sets in rapidly.

pletely blocked and stagnation sets in. Note in the stagnated vessels the gradual obliteration of the outlines of the corpuscles.

- d.* The emigration of the white corpuscles from the capillaries and veins. This begins as the circulation becomes slow; a white corpuscle which is adhering to the wall of a capillary or vein should be noted at intervals of 10 to 15 minutes.
- e.* The diapedesis of the red corpuscles from the capillaries; this is best seen in the capillaries in which the current has almost stopped.

Notice that these effects are local, that they are of greatest intensity in the spot touched, that they extend for some distance round, but that the circulation in the rest of the web is normal. If the injury to the vessels from the creosote has been slight, the circulation may be seen to be re-established in the stagnated spots, the corpuscles gradually recover their outline and are carried off by the current; this is not seen if stasis has set in i.e. if the blood has clotted.

7. Observe now the circulation in the tongue; the frog being on its belly, draw forward the tongue over the hole in the stage and pin out the two cornua; the tongue at first pale soon becomes flushed and its vessels full of blood. With a low power the peripheral layer in the arteries and veins will probably be seen better than in the web. The phenomena of inflammation (§ 6) can

be well seen in this or in the mesentery, in these further the œdema will be more obvious. To observe the circulation in the mesentery, place the frog on its back, cut through the skin and abdominal muscles on one side, draw out and pin over the stage a loop of the mesentery.

### DEMONSTRATION.

Circulation in the mylo-hyoid muscle of the frog.

## LESSON XIII.

### STRUCTURE AND ACTION OF THE HEART.

#### A. HEART OF SHEEP<sup>1</sup>.

1. Observe the attachment of the parietal pericardium to the roots of the great vessels.

Remember that the parts of the heart which are right and left in the body are called right and left after removal. The front of the heart may be recognized by a groove filled with fat, the interventricular sulcus, which runs from about the middle of the base of the ventricles to rather below the middle of the right margin of the heart. The front is also more convex than the back. Holding the heart with the front towards you, note that the right ventricle, which will be on your left hand, is much more yielding than the left ventricle, which will be on your right hand. Note also the pulmonary artery arising nearly in the middle line of the heart at the upper part of the ventricles, and immediately behind this the aorta.

<sup>1</sup> The heart should be obtained from the butcher with the pericardium; to secure this it is advisable to purchase the 'bag,' i.e. the heart with the lungs still attached to it.



2. Tie a short glass tube into the superior vena cava and connect with it a piece of india-rubber tubing. Ligature the inferior vena cava and the left vena azygos which opens close beside it. Tie a glass tube about two feet in length into the pulmonary artery. Fill the india-rubber tubing with water, and squeezing it press the water onwards. The water will amount in the tube connected with the artery, and will only descend a little way on unclasping the india-rubber tubing. Pour water into the long glass tube by means of a funnel, and observe the column of water which the semilunar valves will sustain. Note the distension of the arterial walls and the bulging at the attachment of the valves. When the pressure of the column of fluid is removed the artery by its elasticity returns to its previous dimensions.
3. Repeat the above observation with the pulmonary veins and aorta.
4. Compare the united sectional areas of the superior and inferior venæ cavæ when distended, with the area of the aorta below the origin of the innominate artery.
5. Having removed the tubes, lay open the superior and inferior venæ cavæ, and bring the incisions to meet in the front of the auricle. Note
  - a. The size and form of the auricular cavity.
  - b. The auricular appendage with its muscular fretwork.

- c. The **septum auricularum**.
  - d. The **fossa ovalis**, or expression of the foetal foramen ovale, which is early closed by the growth of the septum auricularum.
  - e. The **Eustachian valve**, a slightly projecting membranous fold, immediately beneath the entrance of the inferior vena cava, and again beneath this.
  - f. The opening of the comparatively large **left azygos vein**.
  - g. The auriculo-ventricular orifice.
6. Cut open longitudinally the azygos vein, and observe the **coronary vein** opening into it a very short distance from the heart.
  7. Cut away most of the auricle, and holding the ventricle in the left hand, pour water suddenly into the auriculo-ventricular orifice. The auriculo-ventricular valve will float up and close the orifice. Note the star-shaped junction of the valve-flaps.
  8. Introduce a pair of scissors between two of the valves, and cut through the wall towards the apex. Having arrived at the bottom of the ventricular cavity, turn the scissors sharp round and carry an incision at an acute angle with the previous one, alongside the septum, towards, but not into, the pulmonary artery. Lifting up the flap, note

- a. The thickness of the ventricular wall, the projections of its inner surface or *columnæ carneæ*. The band of muscle (*moderator band*) running from wall to wall of the ventricle across its cavity.
  - b. The ventricular cavity does not extend to the apex.
  - c. The **tricuspid valve**, its form, and attachment to the auriculo-ventricular ring, the **chordæ tendineæ**, and their attachment to the summits of the papillary muscles.
9. Holding the heart vertically, pour water into the pulmonary artery; observe from below the form of the semilunar valves, and their mode of closing.
10. To observe the valves from above, insert into the pulmonary artery a short wide tube, fill it with water, and cover it with a piece of glass, excluding air-bubbles.
11. Prolong the incision of § 8 so as to lay open the pulmonary artery. Note
- a. The form and attachment of the semilunar valves.
  - b. The small nodule of tissue in the middle of the free edge of each valve, the **corpus Arantii**.
  - c. The slight depressions in the arterial walls opposite each valve, the **sinuses of Valsalva**.

12. Lay open the left auricle in a manner similar to that employed for the right. Note that the left auriculo-ventricular valve, the **bicuspid** or **mitral** has but two flaps. Observe its manner of closing (cp. § 7).
13. Lay open the left ventricle in a manner similar to that employed on the right side, carrying the incision at first along the extreme left of the heart. Note the thick walls, the mitral valve, &c.
14. Lay open the aorta, and examine its semilunar valves, corpora Arantii, and the sinuses of Valsalva, which are here very distinct. Note that the **coronary arteries** open respectively into the two anterior sinuses.

#### B. HEART OF FROG.

1. Expose the heart of a just-killed frog in the manner directed in Lesson XI. B. II. With the pericardium intact, observe the pulsations of the heart, noting the alternate beats of the auricles and the ventricle; and the synchronous beats of the two auricles.
2. Lay open the pericardium and observe
  - a. The synchronous contractions of the two auricles, followed almost immediately by
  - b. The contraction of the ventricle, note that

the ventricle during its contraction or systole becomes pale and conical, and that its apex is thrown forwards and upwards.

- c. The slight contraction of the bulbus arteriosus immediately succeeding the ventricular systole.
  - d. The pause, or diastole, which follows before the auricle again beats.
  - e. The increased redness and distension of the ventricle after the auricular, and immediately preceding its own systole.
3. Divide the band attaching the ventricle to the posterior pericardial wall, and turn the apex of the ventricle over. Observe
- a. The junction of the two superior venæ cavæ with the inferior vena cava to form the sinus venosus.
  - b. The white line, roughly  $\vee$ -shaped, marking the junction of the sinus venosus with the right auricle.
  - c. The cardiac branches of the pneumogastric, running along each superior vena cava and then plunging into the interior of the heart.
  - d. The wave of contraction; it starts in the vena cava, spreads to the sinus venosus,

almost immediately after the auricles contract, then the ventricle, and finally the bulbus arteriosus.

4. Make now a transverse cut through the skin of the frog just below the jaw, and carry the cut as far as the vertebral column; cut through *all* the muscles proceeding from the head of the humerus and from the part of the sternum left attached to it, to the hyoid bone or to the angle of the jaw.

Coming up from underneath the angle of the jaw and stretching towards the lower extremity of the hyoid bone will be seen a thin narrow band of muscle and two small white fibres, one, the glossopharyngeal nerve, running along its upper border, the other, the pneumogastric nerve, running along its lower border. Very carefully separate the pneumogastric from the surrounding tissue, and place a loose ligature around it, it will be seen to divide into two branches, the smaller branch, the laryngeal, may be cut through. It will be safer not to attempt to dissect out the pneumogastric close to the heart.

The nerve may be ligatured close to the skull (some care is required in doing this) and cut above the ligature.

Pass an interrupted current through the pneumogastric nerve. It is well to place a small piece of thin india-rubber membrane underneath the nerve to prevent contraction of the neighbouring muscles by an escape of current.

- a. Observe that during and for a short time after the passage of the current, the heart remains with all parts in diastole. (If no effect is produced push the secondary nearer the primary coil.)
- b. The period of rest (inhibition) may be followed by a period (reaction) in which the beats are quicker and more forcible; and then the previous normal condition is regained.

Now stimulate the pneumogastric nerve, indicating on the curve by means of a time-marker (cp. Appendix) the moment at which stimulation begins, and ends. Note that the heart does not stop *immediately* after the current is sent into the nerve.

5. Place the frog on a stage and arrange a lever (cp. Appendix) so that it presses lightly on the ventricle, and bring the end of the lever to mark on the revolving drum. Take a tracing of the ventricular pulsations with the drum at a moderate speed.

Note the rise and fall of the lever, indicating the change of form during contraction. The rise increases at first rapidly, then more slowly, to a maximum, and the fall is similarly at first slight, then more rapid, but finally slow again.

6. Turn the heart over and stimulate the line of junction of the sinus and right auricle; the heart will stop beating just as it did when the pneumogastric was stimulated.

7. Carefully cut away the connective tissue around the great vessels, tie the superior venæ cavæ close to the heart, pass a silk ligature underneath the bulbus arteriosus and two underneath the inferior vena cava. Make a loose knot in them so that they can be tightened at any moment. Cut across the aorta and stop up the blood. With a fine pair of forceps raise up the wall of the inferior vena cava close to the liver. With fine pointed scissors, make a cut in the vein and with the lower of the two ligatures tie in it a small cannula, wash out the heart with salt solution in the manner given in Lesson XII. cp. § 4. Inject a .5 p. c. solution of gold chloride until the solution begins to issue from the aorta. Then ligature the bulbus arteriosus. Again inject, and whilst the heart is distended tie the remaining ligature round the inferior cava just beyond the end of the cannula. Cut out the heart, immerse it in .5 p. c. gold chloride solution and leave it for ten to fifteen minutes. Then remove it to water, cut open the auricles and shake so that the gold chloride is thoroughly washed out of it. Transfer to water acidulated with acetic acid and expose to light for a day; when it is well stained, observe the septum between the auricles, cut away the auricles from the septum and cut away the ventricle, in removing the last portions of the auricles it is well to examine the septum from time to time under a low power. Mount the septum in glycerine. Observe



- a. The two bundles of nerve fibres running down the septum and having clusters of nerve cells on them (this is best seen with a low power); a few of the nerve fibres are medullated.
- b. From the nerve bundles, nerve fibres extend, forming a plexus over the septum; in this plexus nerve cells occur either singly or in small groups.
- c. Not infrequently a cell may be seen to give off a process, sometimes a **spiral process** may also be made out.
- d. The septum is chiefly composed of a thin plexus of fibres made up of faintly-striated muscle cells, the cells and their nuclei are elongated and more nearly resemble in form the cells of unstriated muscle than the cells of mammalian heart muscle (cp. Lesson VIII. § 12). The outlines of the individual cells are not distinct.
- e. No capillaries are present.

Numerous nerve fibres and cells may also be seen in the sinus and at the junction of the septum with the ventricle (Bidder's ganglia); a few occur in the auricles and the basal portion of the ventricle. A piece of the auricles should be mounted in glycerine to observe the interlacing bundles of fibres, the further development of which gives the ventricle the spongy appearance shown in a section; as in the septum (and rest of the frog's heart) no capillaries will be seen.

## DEMONSTRATIONS.

1. Experiment of Stannius.
2. The antagonistic effects of muscarin (or pilocarpin) and atropin on the heart.
3. The action of the mammalian heart.
4. Pneumogastric inhibition in the mammal.
5. Sounds of the heart,
6. Endocardial pressure of frog.
7. Effect of constant current and of successive induction shocks on the ventricle apex.
8. Rhythmical contraction of ventricle apex under pressure.
9. Latent period of ventricle apex.

## LESSON XIV.

### BLOOD PRESSURE.

#### A. MINOR ARTERIAL SCHEME<sup>1</sup>.

1. Clamp the india-rubber tube at its proximal end close to the pump, and leave the glass tube open so that all the water flows through the latter. Work the pump with a uniform force at about 30 to 40 strokes a minute. To ensure regularity, the strokes had better be timed with a metronome. The water will flow from the open mouth of the glass tube in jerks, corresponding to the strokes of the pump. At each stroke as much will issue from the distal end as enters at the proximal end.
2. Introduce into the open mouth of the glass tube a fine nozzle, so as to offer considerable resistance to the outflow of fluid. Work the pump with the same force and frequency as before. The outflow will still be intermittent, though less fluid will issue from, and consequently less enter into, the tube at each stroke.

<sup>1</sup> See Appendix.

3. Clamp the proximal end of the glass tube and unclamp the elastic tube. Let the distal end of the latter be quite open. Work the pump as before. There being little resistance to the outflow, the elasticity of the tube is not called into play, and consequently the flow will be, as in the case of the glass tube, intermittent.
4. Working the pump as before, insert the fine nozzle into the open mouth of the tube. Considerable resistance will now be offered to the outflow of fluid, the elasticity of the walls of the tube will be called into play, and the water will issue from the end of the tube in a continuous instead of an intermittent stream. If the tube be sufficiently long and sufficiently elastic in proportion to the force and frequency of the strokes, the flow will be absolutely continuous.

## B. MAJOR ARTERIAL SCHEME<sup>1</sup>.

The pump represents the heart; the small tubes represent the resistance of the small arteries and capillaries. The tubes on the proximal side of this resistance represent the arteries, those on the distal side the veins.

### 1. **The Mercurial Manometer.**

The manometer A is connected with the arterial, V with the venous tubes.

<sup>1</sup> See Appendix.

- a. Open the clamps marked  $c$ ,  $c'$  and  $c''$ , so that as little resistance as possible intervenes between the arterial and venous tubes. Bring the manometers to mark on the revolving cylinder, placing V about an inch under A, *in the same vertical line*. Work the pump steadily, regulating the time with the metronome.

In A, the mercury rises at each stroke, and in the interval between each two strokes falls again to its previous level. (The momentum of the mercury frequently carries it below this level, and the descent may be followed by one or more oscillations.)

In V, a similar rise and fall is observed, of nearly if not quite the same extent.

- b. Close the clamps  $c$ ,  $c'$  and  $c''$ , so that the capillary resistance becomes very considerable. In A, the mercury rises rapidly at the first stroke, and at the end of the stroke begins to fall again, but more slowly than was the case in *a*. It has not fallen far before the second stroke raises it to a higher level than before. On falling still again, it is once more raised to a yet higher level, but the increase is not so great as before. Each succeeding stroke has a similar effect. Thus at the end of a few strokes, *the mean arterial pressure* is reached, marked only by comparatively small oscillations corresponding to the strokes of the pump.

On the strokes ceasing, the mercury *gradually* falls until the previous level is reached.

In V the mercury rises to a much less extent than was the case in *a*, a slight mean pressure much less than in A is established, marked either with no oscillations at all or such as are much less conspicuous than those of A.

*Owing to the presence of the resistance, a mean pressure (arterial blood pressure) is established on the proximal (arterial) side of the resistance. This pressure is marked by oscillations synchronous with the strokes of the pump. On the distal (venous) side the mean pressure is much less and the oscillations are either slight or altogether absent.*

## 2. **Flow from Arteries and Veins.**

Remove the clamps from the fine nozzles *a* and *v*. Let the clamps *c*, *c'* and *c''* remain closed. Set the pump going. The flow from *a* on the proximal (arterial) side is in jets; that from *v* (venous) side is uninterrupted or nearly so.

## 3. **Sphygmograph.**

Bring the levers  $S_a$  (arterial side) and  $S_v$  (venous side) to write on the revolving drum, one under the other.

*a.* Open the clamps *c*, *c'* and *c''*, and set the pump going. The two levers describe two nearly straight lines, a slight rise only being evident (and that to about the same extent in both) at each stroke.

*When there is little or no resistance in the capillaries, comparatively little distension of the arterial walls is produced at each stroke of the pump.*

- b. Close the clamps  $c$ ,  $c'$  and  $c''$ .

The lever  $S_a$  now describes a well-marked curve with each stroke of the pump.

Observe the sudden rise to a maximum, the commencing fall, the break in the fall, followed by a slight rise (dicrotic wave) and the final descent.

The lever  $S_v$  describes now a straight line.

*The rise in pressure at each stroke indicated by the mercurial manometer is accompanied by a distension of the proximal (arterial) part of the tubing, indicated by the rise of the lever. This is the pulse.*

*On the distal (venous) side of the resistance no pulse is visible.*

#### 4. **Progression of the Pulse-wave.**

Place two levers, one  $S_a$ , as near as possible to the pump, the other  $S'_a$ , as near as possible to the resistance. Bring the two levers to mark on the cylinder *the one exactly beneath the other.*

(The pressure exerted by the two levers must be as nearly equal as possible.)

Observe that each rise of  $S_a$  begins a little before, and is over a little before that of  $S'_a$ . In other words, the pulse of  $S'_a$  is a little later than that of  $S_a$ .

(By means of a tuning-fork this interval may be

measured, and the length of tubing between the two levers being known, the rate of progression of the pulse-wave ascertained.)

5. While the pump is working, the clamps being closed and the manometers A and V tracing their curves, *gradually* diminish the resistance by opening slowly first  $c'$  and then  $c''$ . The arterial pressure curve will gradually fall, still marked by the pulse oscillations; the venous curve will gradually rise.

*Diminution of capillary resistance lowers arterial, but increases venous pressure.*

6. Close the clamps  $c'$  and  $c''$ , and take tracings with the manometers, then gradually reduce the strength of the strokes of the pump. Both arterial and venous pressure will diminish.
7. The clamp  $c$  being closed, the main arterial trunk of the scheme divides into two chief branches, X and Y, each with its own resistance and venous tube. Leave the clamps  $c'$ ,  $c''$  closed, and put clamps on the tubing immediately beyond  $x$  and  $y$ .
  - a. Work the pump with great regularity, and measure the quantity of fluid which escapes during a given time (say ten seconds) from the venous tube of X, and from that of Y, by the side tubes  $x$  and  $y$ .
  - b. The clamp  $c''$  of X remaining closed, open



that  $c'$  of Y, and the pump working exactly as before, measure again the outflow during ten seconds.

The outflow of Y will be increased. That of X on the other hand will be diminished, though the resistance in X is the same as before.

*The flow of blood through an artery is dependent not only on the resistance offered by its own small arteries and capillaries but also on that of other arteries.*

### DEMONSTRATIONS.

1. The effects in the rabbit on the temperature of the ear, and on the calibre of its blood-vessels, following
  - a. Stimulation of the central end of the great auricular nerve.
  - b. Section of the sympathetic nerve in the neck.
  - c. Stimulation of the peripheral end of the sympathetic.
2. Normal kymographic tracings of the blood-pressure of a mammal obtained by the use of a mercurial manometer.
3. The effects on the arterial blood-pressure, as indicated by the tracing, produced by
  - a. Inhibition of the heart through stimulation of the peripheral end of the vagus.

- b.* Dilatation of the small blood-vessels through stimulation of the central end of the depressor nerve.
4. Methods of measuring the velocity of the blood-current in large vessels.
5. Comparison of venous and arterial pressure.
6. Method of using the sphygmograph.
7. Method of using the cardiograph.

## LESSON XV.

### SALIVARY GLANDS AND PANCREAS. SALIVA.

#### A. MUCOUS SALIVARY GLAND.

1. Prepare sections of a dog's submaxillary gland which has been placed in 75 p. c. alcohol for an hour and then in absolute alcohol. Stain the sections with carmine (best dilute) or hæmatoxylin, and mount them in glycerine.

Under a low power observe

- a.* The division of the section into irregular angular areas, by connective-tissue septa, which, if the section includes the circumference, will be seen to proceed from the sheath of the gland. These are the primary **lobules**; they may be seen to be divided into smaller lobules, but probably not distinctly.
- b.* The **alveoli**, appearing as small roundish bodies closely aggregated together to form the lobules; each will be seen to consist of

a group of cells more or less surrounded by connective tissue, continuous with that of the septa.

- c. At intervals oblique and transverse sections of the small **ducts**. They are usually stained darker than the alveoli, are not surrounded by a sharp ring of connective tissue, and have a well-defined lumen.
2. Under a high power observe that
    - a. The alveoli vary considerably in size, and frequently have no obvious lumen; when visible the lumen is usually an irregular central space between the cells.
    - b. The **mucous** cells are comparatively large; most have a disc-shaped nucleus situated in the outer part of the cell near the basement membrane; in some, the nucleus is spherical and lies farther from the basement membrane. Around the nucleus is a small amount of stained cell-substance, from this a stained network may more or less clearly be seen stretching throughout the cell, the rest of the cell-substance stains little or not at all.
    - c. The **demilune cells**, occurring often in groups, lie immediately beneath the membrana propria, and are stained throughout: they are generally half-moon shaped, and often have two nuclei; they frequently send processes in between the mucous cells, and then appear simply to fill up the spaces

between the mucous cells and the membrana propria.

- d.* The epithelium of the small ducts consists of a single row of slender columnar cells, the inner borders of which apparently coalesce and form a distinct ring bounding the lumen: there is no such distinct boundary to the outer (circumferential) part of the cell, which especially in hæmatoxylin specimens has a well-marked striation. Each cell contains an oval nucleus, situated a little on the inner side of the centre of the cell.
3. Take a *small* piece of a dog's submaxillary gland which has been for three to six days in a 5 p. c. solution of neutral ammonium chromate, and tease it out in the same fluid. Observe the isolated mucous and demilune cells, noting in the mucous cells that the deep-seated end, in which the nucleus lies, is prolonged into a process, and that this, together with a varying amount of the cell-substance around the nucleus, is more granular and opaque than the rest of the cell. The cell-network may also be obvious.
4. Examine a mounted specimen of a dog's submaxillary gland which has been taken after prolonged secretion<sup>1</sup>. Observe under a high power that

<sup>1</sup> In a dog under morphia and chloroform the chorda tympani (or chorda tympani and sympathetic) is stimulated with a fairly strong interrupted current for alternate minutes during six hours about.

- a. The mucous and demilune cells are much more alike.
- b. The mucous cells are smaller, and a much larger part of their cell-substance is stained, the unstained part being as before next the lumen. Their nuclei are spherical instead of disc-shaped, lie more towards the centre of the cells, and have conspicuous nucleoli.

Some alveoli and patches of alveoli shew the changes mentioned above much more distinctly than others, in some the only changes observable are that the demilunes are more conspicuous, and the nuclei of the mucous cells spherical.

## B. SEROUS SALIVARY GLANDS.

1. Prepare specimens of a mammalian parotid gland or of a submaxillary gland of a rabbit. The tissue may have been preserved in alcohol (cp. A. § 1) or in .2 p. c. chromic acid. Compare with the section of the mucous gland (A). Note that in the alveoli
  - a. The cells are more or less polyhedral, having less rounded outlines than the cells of the mucous gland. One kind of cell only is present.
  - b. The cells stain fairly equally throughout and appear to be densely granular.
  - c. The nuclei are spherical (unless shrunken

by the reagents used) and are placed nearly in the centre of the cells (they are usually a little nearer the outer side).

2. Tease out in normal salt solution a small piece of the parotid of a rabbit (preferably one which has been killed eight to ten hours after a full meal).

Observe the numerous granules in the cells.

### C. PANCREAS.

1. Cut sections of 'resting'<sup>1</sup> pancreas (dog, rabbit or frog) which has been preserved in osmic acid; mount the sections in dilute glycerine. Observe
  - a. Under a low power; the gland consists of lobes, lobules and alveoli like the serous and mucous glands.
  - b. Under a high power; the cells contain a great number of granules which stretch nearly or quite to the outer border; the nuclei are more or less completely hidden by the granules.
2. Cut sections of active<sup>1</sup> pancreas and compare with the above.

<sup>1</sup> By a 'resting' gland is meant one which has not been secreting, or has been secreting slightly only, for several hours; by an 'active' gland is meant one which for an hour or more has been secreting rapidly. In both cases the animal is understood to be in a good state of nutrition; the pancreas of an animal which has long fasted is not a 'resting' pancreas. With the dog or rabbit the gland should be taken five to

- a. The granules are fewer, being absent from the outer part of the cell, thus forming an **inner granular** and an **outer non-granular zone**.
  - b. The spherical nucleus is more obvious (partly in consequence of the disappearance of the granules) and is situated chiefly or entirely in the non-granular zone, the nucleolus is usually distinct.
  - c. If the gland has been taken after very active secretion the cells may be nearly free from granules, the remaining granules will be smaller and the lumina will be more obvious.
3. Prepare sections of an active pancreas which has been hardened in spirit, stain with carmine and mount in acid glycerine.

The division of the cells into granular and non-granular zones will be seen as in the osmic acid preparations; the inner zone however appears as a confusedly granular mass instead of as an aggregation of separate spherical granules; the outer zone appears homogeneous and stains more deeply than the inner zone.

six hours after a full meal for the active state; about twelve hours after a full meal for the resting state. With the frog the pancreas should be taken in eight to ten hours after a full meal for the active state, in one to two days for the resting state. Worms serve best for feeding frogs. In unhealthy frogs and in frogs which have long fasted, the pancreas-cells have usually a distinct outer non-granular zone. In all cases the pancreas should be placed in osmic acid 1 p.c. for two to twenty-four hours as convenient, then washed, and transferred to 75 p. c. alcohol.



## D. SALIVA.

1. Look at a little fresh saliva under the microscope with a high power. Disregarding the flat epithelial cells from the mucous membrane of the mouth, note the salivary corpuscles; they are larger than the ordinary white blood-corpuscles, but in other respects closely resemble them. In many, a very active Brownian movement of the granules within the corpuscle may be observed.
2. Test with neutral litmus paper the reaction of a drop of saliva, it will be found to be alkaline.
3. Induce the secretion of saliva by chewing a small piece of india-rubber tubing, by filling the mouth with ether vapour, or by rubbing the tongue with a crystal of tartaric acid.  
If time allows let the saliva stand until the turbidity has settled down into a sediment. To a few c.c. of the fluid add strong acetic acid; **mucin** will separate out as a stringy mass, which does not dissolve in excess of acid. Shake gently, or stir it with a glass rod the mucin will form a clump, remove it, and if the fluid is cloudy, filter.
4. To the clear fluid add a drop or two of a strong solution of potassium ferrocyanide. The slight precipitate which results indicates the total quantity of **proteids** present (cp. Lesson III. § 16). If the reaction is not obvious, test another small portion with Millon's reagent.

5. To a few c.c. of **starch** mucilage<sup>1</sup> 1 p.c. in a test-tube add a drop or two of a moderately strong solution of iodine ; an indigo-blue colour will be produced, if the colour is very dark fill up the test-tube with water.
  
6. To 5 c.c. of a 5 p.c. aqueous solution of dextrin<sup>2</sup> add a strong solution of iodine drop by drop. A deep brown-red colour will be produced. Warm ; the brown-red colour will rapidly disappear, a light brownish-yellow tint due to the iodine remaining ; on cooling the dextrin colour returns. Now add water ; as the dextrin solution becomes more dilute, the red tint becomes less obvious, the fluid appears yellow-brown. That this colour is not due to the iodine can be seen by warming the fluid.
  
7. To 5 c.c. of a .1 p.c. solution of **dextrose** (grape-sugar) add an excess of a strong solution of sodium hydrate and a couple of drops of a 1 p.c. solution of cupric sulphate ; the precipitate of hydrated cupric oxide at first formed will dissolve, giving a blue solution. Boil ; the cupric oxide will be reduced and a yellow or red precipitate of

<sup>1</sup> To prepare the starch mucilage, take 1 gram of starch, and rub it into a thin paste with cold water. Pour it into a beaker containing one hundred c.c. of boiling water, boil for a few minutes and place it aside to cool. It should have no lumps in it and should be thin enough to be measured out readily with a pipette.

<sup>2</sup> This may be bought at a chemist's or it may be prepared by boiling a little starch with sulphuric acid about 3 p.c., until a drop of the fluid gives a red-brown colour with a drop of iodine.

cuprous oxide will be produced (**Trommer's test**). When a very small quantity of sugar is present no distinct precipitate is obtained, but the fluid is decolourized or turns faintly yellow. Repeat this, adding half a dozen drops of a strong solution of cupric sulphate; the reaction will be much less obvious, partly owing to the blue colour of the dissolved hydrated cupric oxide and partly to the brown-black precipitate of anhydrous cupric oxide.

8. In this and the following experiments the saliva<sup>1</sup> used should be diluted 5 to 10 times.

Mix equal quantities (say 5 c.c.) of starch and saliva in a test-tube and place in a water bath at about 37° C. At short intervals (1 to 3 minutes) take a drop of the mixture and add it to a drop of iodine on a porcelain plate. The colour produced at first blue will later become a blue-violet, a red-violet, a red-brown and a light-brown yellow, according to the relative amounts of starch and dextrin present, finally there will be no colouration, no more starch or dextrin (erythrodextrin) being left. Then divide the fluid into two parts.

<sup>1</sup> An aqueous extract of a ptyalin-containing gland may be used instead of saliva. To prepare the extract take (e.g.) the parotid glands of a rabbit and having removed the connective tissue around them chop them up well and place the pieces in about 200 c.c. of water; leave in the warm for an hour or two and filter. The aqueous extract thus prepared contains much proteid material, and this obscures the reducing action of sugar on cupric hydrate in Trommer's test when a small quantity only of sugar is present.

- a.* Add iodine ; no colouration is produced (there may be a little tint from dextrin since in mixing the drops a faint colour may escape notice which in a larger quantity of fluid is obvious).
- b.* Add an excess of sodium hydrate and a drop of 1 p.c. cupric sulphate and boil ; the fluid turns yellow and a yellow precipitate will be formed showing the presence of sugar.
9. Boil a little saliva, add it to starch in a test-tube and warm. In half-an-hour divide into two parts and test as in § 8 *a*, *b*. The blue colour from starch will be as distinct as at first, no trace of sugar will be found ; hence boiling destroys the ferment (ptyalin) which converts starch into sugar.
10. If the saliva used in § 8 converts starch into sugar very rapidly dilute it still further for the following experiment. Into each of three test-tubes pour equal quantities of saliva and starch. Place *A* in a water bath at about 37° C., leave *B* at the temperature of the room (noting it) and place *C* in a vessel with ice (it is best to cool the starch and saliva before mixing them). At short intervals take with a glass rod drops from each and add them to drops of iodine on a porcelain plate and so compare the rate of disappearance of starch (cp. § 8) in the three mixtures. It will disappear much more quickly in *A* than in *B* ; in *C* there will be very little change.

When no starch is left in *A*, remove *C* from the ice and place it in the warm chamber and test at intervals as before, the starch soon disappears. Hence a temperature of 0°C. arrests the action of saliva but does not destroy it.

11. Neutralize a small quantity of saliva; to 5 c.c. of this add 5 c.c. of HCl ·2<sup>1</sup> p.c., the mixture thus contains ·1 p.c. HCl. Place at 37° C.<sup>2</sup> for ten minutes, add 3·5 c.c. Na<sub>2</sub>CO<sub>3</sub> ·4 p.c. and complete the neutralization with a more dilute solution. Add a few c.c. of starch and place at 37° C. In half-an-hour test for starch and sugar; starch will be found but no sugar, hence the acid has destroyed the ptyalin.

12. Place in one dialyser<sup>3</sup> (*A*) 15 c.c. of starch and in another (*B*) 10 c.c. of starch with a little saliva.

Test from time to time the external water in each. That from (*A*) will give no trace of starch or sugar. That from (*B*) will contain sugar, but no starch. Sugar dialyses, but starch does not.

<sup>1</sup> Pure strong commercial hydrochloric acid contains about 33 p.c. HCl.

<sup>2</sup> In these and in similar experiments (Less. xvi.) 37° C. is taken since that is very nearly the normal body temperature of man, but a rather higher or a rather lower temperature will serve equally well.

<sup>3</sup> A very convenient dialyser may be made from a short length of parchment paper tubing (Papier-Därme) sold by Carl Brandegger, Ellwangen, Württemberg (cp. also Gamgee, *Physiological Chemistry*, Vol. I. p. 6).

13. Add a little raw starch<sup>1</sup> to saliva and place in the warm chamber, shaking frequently. The raw starch is converted into sugar very slowly, it may be an hour or more before any sugar can be detected.

### DEMONSTRATION.

Effect on the submaxillary gland of the dog of stimulating the chorda tympani and the sympathetic nerves.

<sup>1</sup> Arrow-root will do very well.

## LESSON XVI.

### STOMACH. GASTRIC JUICE. MILK.

#### A. STRUCTURE OF THE STOMACH.

1. Make transverse vertical sections from the fundus or greater curvature of a rabbit's stomach which has been preserved in spirit (cp. p. 32, F, § 1) or in chromic acid .2 p.c. Stain the sections with carmine or with aniline blue (the sections are best stained if they are left in a dilute solution of the staining agent one to two days). Observe under a low power
  - a. Externally, the thin connective-tissue layer of the peritoneum.
  - b. The **muscular coat**, consisting of an outer longitudinal and an inner circular layer of unstripped muscle. If the sections are accurately transverse, the former will appear as a cross section of a number of bundles with connective tissue running in between them from the peritoneum, the latter as a continuous layer. On the inner side of this may also be seen a much thinner oblique muscular layer.

- c. The **submucous coat** of connective tissue. If the mucous membrane is in folds the submucous but not the muscular coat will be seen to run up in the folds.
  - d. The **muscularis mucosæ**, or thin stratum of unstriated muscle fibres a little below the glands, this is divided more or less distinctly into an outer longitudinal and an inner circular layer.
  - e. The **mucous coat**. Note in this The gastric glands with their openings and the ridges between the openings. The bifurcation of some of the glands may probably be made out.
2. Observe under a high power
- a. The columnar **mucous cells**, lining the mouths of the glands and covering the free surface of the gastric mucous membrane between the glands; they are long slender cells becoming shorter in passing down the mouths of the glands; the upper third of the cell is usually much more transparent than the remaining portion, and the nucleus lies at about the lower third. These cells may have become detached if the tissue has not been removed from the animal soon after death.
  - b. The large deeply stained **ovoid** or **border cells** with ovoid nuclei, and the short columnar or polyhedral **central cells** with spherical



nuclei. At the base of the glands the central cells are usually most numerous, the ovoid cells being placed between them and the basement membrane; towards the neck of the glands the ovoid cells usually increase in number, in the neck the majority of the cells are ovoid; they are however considerably smaller than in the body of the glands. The ovoid cells frequently cause a bulging outwards of the basement membrane, this is especially the case if the animal has been killed soon after it has fed.

- c. The fine connective tissue immediately internal to the muscularis mucosæ, surrounding the bases of the glands, and sending up processes between them. Towards the surface the fibres have a much closer arrangement, and appear as a number of slender, comparatively dark, bands, which stain deeply. Mark the scarcity of leucocytes.
3. Compare the longitudinal vertical section previously made (Less. VIII. § 11) of the muscular coat of a dog's stomach with the transverse vertical section of the muscular coat of the rabbit's stomach (§ 1), in the former the muscular coats are much thicker.
4. Take a small piece of the fundus region of a rabbit's gastric mucous membrane and prepare a section parallel to the surface through the bodies of the glands. Observe

- a.* The central cells forming a tube with very small lumen.
  - b.* The comparatively rare ovoid cells outside the central cells.
- 5. From the pyloric end of the stomach prepare vertical sections and stain them with hæmatoxylin, compare these with the sections made of the cardiac end. Note
  - a.* The greater thickness of the longitudinal and circular muscular layers.
  - b.* The wider and longer mouths to the glands, their more frequent branching and the absence of ovoid cells (if the section passes through the upper part of the pyloric region a few ovoid cells may be seen). The cells below the mouths of the glands (pyloric gland cells) resemble in general appearances the central cells of the cardiac end of the stomach.

## B. STRUCTURE OF THE ŒSOPHAGUS.

- 1. Make transverse vertical sections from the lower third of a rabbit's œsophagus, which has been hardened in potassium bichromate 1 p. c., and compare them with the corresponding sections of the stomach. Note the following points of contrast:
  - a.* The external muscular layers contain striped as well as unstriped muscular fibres; sections

from the upper part of the œsophagus show no unstriped fibres.

- b. The submucous tissue contains small *serous* and *mucous glands* (cf. Lesson XV.). Each of these consists of a duct, dividing and ending in dilatations, the alveoli.
- c. Traces of the muscularis mucosæ.
- d. The papillæ of the mucous membrane.
- e. The epithelium forming a layer several cells deep, the deeper being columnar or spheroidal, the superficial cells flattened (cf. Epidermis, Lesson XXIV.).

## C. GASTRIC JUICE.

### 1. **Artificial Gastric Juice.**

- a. Tear off the mucous membrane from the stomach of a mammal, cutting away the pyloric region (the stomach of a pig obtained from the butcher's will serve). Mince it finely. Put it in a flask with two hundred times its bulk of hydrochloric acid .2 p.c., and place the flask in a water bath at about 40° C. After some hours a considerable part will be dissolved. Decant, and filter the decanted fluid. A solution of pepsin in hydrochloric acid will be obtained; it will, however, contain a considerable quantity of peptone.
- b. Mince another gastric mucous membrane;

remove with blotting-paper the excess of fluid, add five times its bulk of glycerine and place aside stirring occasionally. It is best to leave the mixture for some days before use, it may be kept almost indefinitely. When required for use, filter through muslin, add to the fluid ten to twenty times its volume of HCl ·2 p.c. and filter.

### **Action of Gastric Juice.**

2. *a.* Take four test-tubes. In *A* place 5 c.c. of hydrochloric acid ·2 p.c. In *B* 5 c.c. of artificial gastric juice. In *C* 5 c.c. of the same juice, carefully neutralized with dilute  $\text{Na}_2\text{CO}_3$ . In *D* 5 c.c. of the same juice, thoroughly boiled. Add the same quantity of fibrin<sup>1</sup> to each, and place in a water bath at about 37°C. Examine from time to time.

*A*, the fibrin will swell up and become transparent, but will not be dissolved; on neutralization it will appear unaltered.

*B*, the fibrin will be digested.

*C*, the fibrin will be unaltered.

*D*, the fibrin will be like that in *A*.

<sup>1</sup> Raw fibrin digests more easily than that which has been boiled or kept in alcohol, it often however contains traces of pepsin so that a slow digestion may take place when acid only is added to it. When it is required to measure accurately the amount of fibrin added, raw fibrin finely chopped up should be placed in dilute HCl until it is well swollen, the excess of acid poured off and the fibrin measured in small tubes containing (e.g.) 2 c.c.

These experiments show that acid alone (*A*) and pepsin alone (*C*) will not digest fibrin, and that pepsin loses its power on being heated to boiling point (*D*). Now add acid again to *C*, and place it in the warm chamber. Digestion will take place. The neutralization has only suspended, not destroyed, the action of the pepsin.

- b.* Take two test-tubes, with 5 c.c. of gastric juice and a morsel of fibrin in each. Place *A* in the warm. Surround *B* with ice, or put it in a cold spot. The fibrin in *A* will be digested rapidly; that in *B* very little or not at all.
3. Take 5 c.c. of artificial gastric juice which has been found to digest fibrin rapidly, neutralize it, filter and add an equal bulk of  $\text{Na}_2\text{CO}_3$  2 p.c. thus obtaining pepsin in the presence of a small quantity of an alkaline salt. Place at about  $40^\circ \text{C}$ . for half-an-hour to an hour. Then add  $\text{HCl}$  until the mixture is distinctly acid (or neutralize and add an equal volume of  $\text{HCl}$  4 p.c.). Add a flock or two of fibrin and warm. Little or no digestion will take place. The pepsin has been destroyed by the alkaline salt.
4. Place 50 c.c. of artificial gastric juice together with some fibrin or other proteid in a beaker and leave in the warm until a small part only of the proteid remains undissolved. Filter and neutralize carefully, a precipitate of acid-albumin

(parapeptone) will be obtained (cp. Less. IX. § 15). Filter off the acid-albumin, the filtrate contains peptones.

5. Determine the following characters of peptones with the solution obtained in § 4.
  - a. Apply the tests for proteids (Lesson III. § 16), Millon's and the xanthoproteic reaction are obtained, but no precipitate is produced with acetic acid and potassium ferrocyanide.
  - b. Boil; it does not coagulate.
  - c. Add excess of sodium hydrate and a drop or two of dilute cupric sulphate, a rose colour is produced which becomes violet when more cupric sulphate is added. Compare the colour reaction with that given by diluted serum or white of egg (Lesson III. § 16 c).
  - d. Pour into one dialyser (*A*) a solution of peptone and into another (*B*) diluted serum or white of egg. Leave for an hour or longer, then apply the xanthoproteic test to the fluid outside the dialyser, a reaction will be obtained from (*A*) only, i.e. the peptone has dialysed, the albumin has not.

#### D. MILK.

1. Examine a drop of fresh cow's milk under the microscope with a high power. It consists of a clear fluid containing a large number of highly refractive **fat globules** of varying size. Add a

drop of osmic acid; in a short time the globules become stained brown-black.

2. Test the reaction of fresh cow's milk with litmus paper. It will be found to be **alkaline**: occasionally it is acid owing to the presence of free lactic acid.
3. Dilute a little milk five to ten times with water; neutralize it with dilute acetic acid, no precipitate will fall. Continue to add the acetic acid drop by drop, a copious precipitate of **casein** will occur carrying down with it nearly all the fat. When there is a distinct flocky precipitate no more acid should be added as casein is soluble though not very readily in excess; it is not precipitated on merely neutralizing since alkaline phosphates are present in milk (cp. Lesson IX. § 16, c). To precipitate the *whole* of the casein the milk must be much diluted.
4. Filter off the precipitate. The filtrate should be clear; if it is not, either too little or too much acetic acid has been added; in this case add either a little more acetic acid or a little dilute sodium carbonate and filter again. Boil the filtrate; a precipitate of **albumin** (with a little globulin) takes place. Filter, and to the filtrate Apply Trommer's test (Lesson xv. D, § 7), a yellow precipitate will be obtained showing the presence of **milk-sugar**.

5. Place a small quantity in a warm place for one or two days; then test the reaction, it will be found to be acid; this is due to **fermentation**, in the process of which the milk-sugar is converted into **lactic acid**.

6. **Action of Gastric Juice on Milk.**

Neutralize with dilute  $\text{Na}_2\text{CO}_3$  a little artificial gastric juice prepared by method (a) § 1, filter and add 5 c.c. of the filtrate to 5 c.c. of fresh milk, place in the warm.

Observe at short intervals the condition of the milk, it will soon form a firm clot so that the test-tube can with safety be held upside down, later the clot shrinks and presses out a nearly clear fluid; the clot continues to shrink for some time.

The **rennet-ferment** in the extract has coagulated the **casein**, and this has carried with it the greater number of the fat globules.

If the amount of rennet-ferment contained in the extract is large the clotting may be almost instantaneous; in this case the experiment should be repeated taking a smaller quantity of the extract and without warming. The extract is neutralized since (cp. § 4) excess of acid of itself precipitates casein.

7. To the milk clotted by rennet-ferment add 5 c.c.  $\text{HCl}$  .4 p.c. and warm for an hour or so, the casein will be converted into peptone by the pepsin of the extract in the presence of acid.



(The fat globules float once more in the fluid but it is much less white than originally.)

### DEMONSTRATION.

Separation of casein and fat from milk by filtration under pressure through a porous cell.

## LESSON XVII.

### INTESTINE. BILE. PANCREATIC JUICE.

#### A. STRUCTURE OF INTÉSTINE.

The outer coats of the intestine have the same general characters as those of the stomach (Lesson XVI. A, § 1, *a—d*), except that there is no oblique muscular layer.

1. Prepare vertical sections of a cat's or dog's **small intestine** hardened in chromic acid .2 p. c. (cp. p. 33 F § 2). Stain with hæmatoxylin (the tissue may be stained before sections are made by placing it in dilute hæmatoxylin for a day). Observe in the *mucous coat*

- a.* The projections of the mucous membrane, or **villi**, either extended and long, or contracted and short with the surface thrown into folds.

Note

- a.* The epithelium, consisting of rather long **columnar** cells, each with a clear free border more or less distinctly striated with vertical lines, rather granular cell-substance, and oval nucleus placed at about the lower third of the cell; the

clear free borders of the cells frequently appear to have coalesced into a narrow highly refractive band, which may be traced over the whole villus.

- $\beta$ . The **mucous** or **goblet** cells, irregularly scattered among the former, sometimes abundant, sometimes scanty or absent; they have an upper ovoid portion which has sharp outlines, is transparent and may be empty, and a lower basal granular portion containing the nucleus.
- $\gamma$ . The **adenoid** tissue, forming the substance of the villus: this consists of a fine meshwork of fibres with nuclei or flattened cells at some of the nodal points. The meshes are seen to be crowded with leucocytes.

There may also be seen with varying distinctness

- $\delta$ . Capillary blood-vessels with the nuclei of their component cells; they may be filled with blood-corpuscles.
- $\epsilon$ . The 'lacteal radicle' as a space in the centre of the villus.
- $\zeta$ . Unstriped muscular fibres as narrow bands running up the villus.
- $\iota$ . The rather deep depressions of the mucous membrane, the **intestinal glands** or **glands of Lieberkühn**. Note that

- a. The epithelium lining them consists of short columnar cells. Observe their gradation into the cells covering the villi; usually they have a clear free border like that of the columnar cells of the villi.
- β. There is usually a distinct basement membrane immediately beneath the epithelium. This is formed of connective-tissue corpuscles very much flattened and fused together into a membranous sac; the outlines of the cells are not seen in the section, but the nuclei are fairly conspicuous.
- γ. The lumina of the glands are in thin sections distinct.
- c. The adenoid tissue around the bases of the glands of Lieberkühn and between them and the muscularis mucosæ. This, unlike the corresponding tissue in the stomach (Lesson XVI. A, § 2, c), has a large number of leucocytes in its meshes.
- d. The **lymph follicles**; either isolated, or aggregated into **Peyer's patches**; the follicles are round or oval masses of adenoid tissue crowded with leucocytes, lying immediately beneath the surface epithelium and usually stretching down into the submucous tissue. They are in the midst of the glands of Lieberkühn, and the villi are absent over them.

They will be more fully studied under Lymphatics (Lesson XVIII. §§ 1, 2, 3).

2. Snip off a few villi from a fresh intestine; tease out some in normal salt solution; place others in osmic acid 1 p. c. for half an hour, then tease out in water or in dilute glycerine. Observe more closely the characters of the cells (§ 1 *a* (*a*) (*β*)). It will be seen that some of the isolated columnar cells branch at their attached ends; and that the goblet cells have usually a tapering process. Where a surface view of a portion of mucous membrane is obtained the goblet cells will appear as clear round spaces.
3. Prepare sections of the ileum or jejunum through the glands of Lieberkühn parallel to the surface, and compare them with the vertical sections (§ 1, *b*, *c*).
4. Prepare vertical sections of the duodenum at its commencement close to the pylorus. In addition to the villi and intestinal glands, note The **glands of Brunner**<sup>1</sup>. Each has a duct with basement membrane, short columnar epithelium and usually distinct lumen; the duct runs down into the sub-mucous tissue and there divides and sub-divides, the end tubes enlarging slightly, like small alveoli; the number of sub-

<sup>1</sup> Brunner's glands stretch some little distance from the pylorus in ruminants and in the pig; in carnivora and rodents they are close to the pylorus and usually small; in the mole they form a marked bulging ring just below the pylorus.

divisions varies greatly in different animals, there is also considerable variation in the form of the tubes and in the appearance of the cells in different animals, generally speaking the cells are much the same in the ducts and throughout the tubes; the nuclei are placed near the basement membrane.

5. Prepare vertical transverse sections of the **large intestine**. Observe

- a. The longitudinal muscular coat, thin except where the section has passed through one of the three conspicuous bands.
- b. The circular coat, thick and well developed.
- c. The mucous membrane, frequently thrown into longitudinal ridges, the sub-mucous tissue running up into the ridges.
- d. The absence of villi.
- e. The intestinal glands (glands of Lieberkühn); they are larger than in the small intestine, and their features, owing to the absence of villi, much more easily seen. The epithelium covering the free intestinal surface or the ridges between the glands consists of long columnar cells with usually a striated clear free border, in the glands the cells are shorter, have no clear border, and the nuclei are nearer the basement membrane; in some animals (e.g. dog) there are many distinct goblet cells.

6. Examine sections of a small intestine in which the blood-vessels have been injected, and note the capillary network round the glands of Lieberkühn, and the small artery running up each villus and dividing into a capillary network just below the cells.
7. Feed a frog with a small piece of bacon; on the next day<sup>1</sup> kill the frog, remove the stomach and intestine, pin the tube out on cork, cut it open along its whole length, and gently wash it with salt solution.

Note that the mucous membrane of the stomach has a yellowish semi-transparent look, whilst the mucous membrane of the intestine is of an opaque white, this is more marked in the upper than in the lower part of the intestine; the rectum is greyish and semi-transparent. Teaze out a small piece of the opaque white mucous membrane in normal salt solution; the epithelium cells are crowded with fat globules, scarcely anything but these being visible.

*Fat is absorbed by the cells of the small intestine, and is absorbed little or not at all by the cells of the stomach.*

8. Pin out pieces of the intestine; place some in 75 p.c. alcohol for an hour, and then in strong

<sup>1</sup> The difference in the tint of the stomach and intestine is still more obvious if the frog be fed again after two days and killed on the subsequent day. The frog is fed by placing the piece of fat in the upper part of the cesophagus, the fat is then usually swallowed at once. For lardening the intestine cp. § 2. p. 33.

spirit; place others in osmic acid 1 p.c. for half an hour, wash and place in 75 p.c. alcohol.

In sections of these pieces note that there are no villi and no proper glands of Lieberkühn. The mucous membrane is however thrown up into considerable folds. In the osmic acid specimens, the cells will probably be so full of deeply stained fat globules that little structure can be seen in them except the hyaline free border; in the sub-mucous connective tissue few or no fat globules are seen.

In the alcohol specimens the cell substance will be seen as a distinct sponge-work or network, the fat globules having been dissolved.

## B. BILE.

1. Test the reaction of bile<sup>1</sup> with litmus paper. If fresh it is *slightly alkaline* or *neutral*.
2. To a small quantity add strong acetic acid drop by drop. A curdy precipitate of *mucin* coloured with the bile-pigment will be thrown down. Since the mucin of bile is not formed in the liver but in the mucous glands and cells of the gall-bladder and duct, the longer the bile has been in the gall-bladder the greater the precipitate which will be obtained.

For the following tests (§§ 4, 5) it is best, although not necessary, to precipitate the mucin with acetic

<sup>1</sup> Ox-gall or sheep's gall may be obtained from a butcher's.



acid, to filter and use the filtrate; before filtering, the bile may be diluted four or five times with water.

- The mucin may also be removed by adding an excess of alcohol, the filtrate from this should be evaporated to dryness, and the residue dissolved in water.
3. *Gmelin's test for bile-pigment.* To a small quantity in a test-tube add drop by drop, nitric acid, yellow with nitrous acid, shaking after each drop; the yellowish green colour becomes first a dark green, then blue, then violet, then red, and finally a dirty yellow. The blue and violet colours are less obvious than the rest. Repeat the test in the following form; place a drop of bile on a porcelain slab, and place a drop of yellow nitric acid so that it runs into the drop of bile; where the fluids mingle, zones of colour, green, blue, violet, red and yellow, from the bile to the acid, are seen.
  4. *Pettenkofer's test for bile-acids*<sup>1</sup>. To a little bile in a test-tube, add one drop of a 10 p.c. solution of cane-sugar (or a small particle of sugar) and shake. Add strong sulphuric acid to nearly the same amount as the bile taken, inclining the

<sup>1</sup> Bile-salts may be prepared in the following manner. Rub ox-gall with animal charcoal into a thin paste. Evaporate on a water bath to complete dryness, and extract with absolute alcohol. The alcoholic filtrate should be colourless. Add to it anhydrous ether as long as any precipitate is produced, and let it stand. The precipitate either crystallizes out or falls to the bottom as a thick viscid syrup; it is a mixture of sodium glycocholate and taurocholate.

test-tube so that the acid settles at the bottom. Gently shake the test-tube from side to side, when the fluids have nearly mixed a deep purple colour is produced. If too much sugar is added, the fluid will turn brown or black; if too little sulphuric acid is added the proper temperature (about 70° C.) for the production of the colour will not be obtained.

5. Add a few drops of oleic acid to 10 c.c. of bile in a test-tube, shake well, and at once mount a drop and observe in it under the microscope the numerous fatty globules. Place the test-tube with the bile in a warm bath for an hour or so, then shake and mount a drop of the fluid; comparatively few fatty globules will be seen in it under the microscope. The oleic acid has combined with the base of the bile-salts to form a *soap* (cp. C. § 4).
6. Place in separate test-tubes 10 c.c. of bile and a couple of drops of oleic acid (*a*); 10 c.c. of bile (*b*); 10 c.c. of water; to each add 2.5 c.c. of melted fresh butter<sup>1</sup>, shake well, and place in the warm bath. The emulsion will last much longer in (*a*) than in (*b*); it will last much longer in (*b*) than in (*c*). *The emulsifying power of bile is slight; but in the presence of fatty acids it forms soaps* (cp. § 6) *which have a much greater emulsifying power.*

<sup>1</sup> If olive oil is used instead of melted butter, it will depend upon the amount of fatty acids contained in the olive oil whether any difference is observed in (*a*) and (*b*).

7. Mount a few crystals of **cholesterin**<sup>1</sup> in water and examine them under a microscope, they consist of rhombic plates.
8. Irrigate the crystals with strong sulphuric acid; they turn red.
9. To a small quantity of chloroform in a test-tube add a little cholesterin and shake, the cholesterin will dissolve; add strong sulphuric acid and gently shake, the upper (chloroform) layer will turn bright red.
10. Digest a little fibrin in 10 c.c. of artificial gastric juice; when the fibrin is dissolved add drop by drop, bile which has been decolorized by filtering through animal charcoal; a precipitate will be formed consisting of parapeptone, peptone and bile acids. (If excess of bile is added especially if it contains taurocholic acid, the peptone and bile acids will be more or less completely dissolved.)
11. Add to the preceding 5 c.c. of .4 p.c. HCl and a few flocks of swollen fibrin; the fibrin will shrink and will be digested slowly or not at all. *Bile acids prevent gastric juice from digesting proteids.*

<sup>1</sup> Cholesterin may be prepared from gall stones (those which have a soapy feel) in the following manner. Powder the gall stones and add a small quantity of strong spirit (or absolute alcohol) and boil; filter hot, using a hot-water funnel; on cooling, cholesterin crystals will separate out. Collect the crystals, place them in a small quantity of spirit containing a little sodium hydrate and boil. On cooling, purified cholesterin crystallizes out; wash the crystals with water.

## C. PANCREATIC JUICE.

**Artificial Pancreatic Juice.**

1. Mince finely a pancreas from a just killed animal, pound it well with clean sand and add about 100 vols.  $\text{Na}_2\text{CO}_3$  .2 p.c. and a little thymol. Place it in the warm for some hours to a day, strain through muslin, filter through linen and then through filter paper.
2. Leave a pancreas moistened with water for a day, then mince it well and add 10 vols. of glycerine. When required for use add to a small portion of this glycerine extract 10 to 20 vols. of  $\text{Na}_2\text{CO}_3$  1.5 p.c., shake, strain through muslin and filter.
3. Mince a pancreas and pound it with sand, for each gramme of gland-substance add 1 c.c. of acetic acid 1 p.c. and mix thoroughly in the mortar for ten minutes; add ten times its bulk of glycerine. In a day or two a little strong solution of sodic carbonate should be added to make the fluid slightly alkaline. When required for use add sodium carbonate as in § 2.

**Properties.**

4. To about 5 c.c. of distilled water in a test-tube add a drop of oleic acid and shake, the fatty globules soon rise to the surface; add 5 c.c.  $\text{Na}_2\text{CO}_3$  1 p.c.; a white precipitate of soap forms; shake, the precipitate partially dissolves and more completely or wholly on boiling.

Examine a drop of the fluid under the microscope, no fat globules will be seen.

5. Place in a warm bath two test-tubes, each containing 5 c.c.  $\text{Na}_2\text{CO}_3$  1 p.c.; melt a little fresh butter in a porcelain dish over a flame and with a warm pipette add an equal quantity (about 2.5 c.c.) of the melted butter to the fluid in each test-tube. To one of these (*a*) add a couple of drops of oleic acid. Shake the test-tubes and replace them in the warm bath, examining them from time to time; the fine emulsion formed on shaking the fluids will last much longer in (*a*) than in (*b*). The emulsion in this case is much greater than with bile (cp. B, § 6).
6. With either of the extracts of § 1 or § 2, make observations on the amylolytic ferment of the pancreas similar to those made in Lesson xv. §§ 8—13 on the amylolytic ferment of saliva.
7. Test the proteolytic action of either of the extracts § 2 or § 3 in a similar manner to that in which the action of artificial gastric juice was tested (Lesson xvi. C, § 2) substituting 1 p.c.  $\text{Na}_2\text{CO}_3$  for .2 p.c. HCl.  
In test-tubes *A* and *D* the fibrin will be unaltered, in *C* it will be very slowly dissolved, in *B* it will be rapidly dissolved, hence sodium carbonate alone does not digest fibrin (*A*), trypsin alone digests it very slowly (*C*), trypsin in the presence of sodium carbonate dissolves it rapidly (*B*), the digestive power of trypsin being destroyed by boiling (*D*).

Experiments corresponding to those of §§ 4, 5, Less. XVI. may also be made; in this case alkali-albuminate instead of acid-albumin is formed.

8. To 10 c.c. of extract § 1 add 5 c.c. of an emulsion of oil of almonds and a little litmus solution. Place in the warm. In a short time the litmus solution will be turned red. The fat-ferment of the pancreas has split up the neutral fat into fatty acid and glycerine.

#### DEMONSTRATIONS.

1. The appearance of the chyle in the lacteals of the mesentery of a rabbit a few hours after a meal.
2. The flow from the thoracic duct.

## LESSON XVIII.

### THE LYMPHATIC SYSTEM.

#### A. LYMPHATIC GLANDS.

1. PREPARE vertical sections of a rabbit's **Peyer's patch** which has been hardened in ammonium bichromate 5 p.c., and stain them with carmine. When stained, mount a section at once, to observe the immense number of leucocytes; shake up the others in a test-tube with water. Look at them under a low power to see if the leucocytes are for the most part shaken out; if so, mount them in glycerine. Select a comparatively isolated follicle, and observe
  - a. The **adenoid tissue** of the follicle (cp. Less. XVII. § 1, *a* ( $\gamma$ )), continuous more or less distinctly with the neighbouring adenoid tissue, and resembling it in all respects except that the fibres are, as a rule, finer, and the meshes smaller.
  - b. Around parts of the follicle, narrow spaces between it and the surrounding tissue; these represent the **lymph-sinus** on the outside of the follicle.

- c. The leucocytes scattered on the outside of, but especially abundant within, the follicle.
2. Examine prepared sections of a Peyer's patch with the blood-vessels injected. Note the capillary network in the follicle showing usually a radial arrangement.
  3. Examine prepared sections of a Peyer's patch with the lymphatic system injected. Note that the injected material envelops to a greater or less extent the separate follicles; it occupies the lymph-sinus spoken of above around each follicle and does not penetrate into the interior of the follicle.
  4. Take a small lymphatic gland (e.g. one of those lying near the sub-maxillary gland in the cat or dog) which has been preserved<sup>1</sup> in ammonium bichromate 2 to 5 p. c. and cut sections passing through the whole gland and including the hilus. Shake the sections in a test-tube with water to get rid of most of the leucocytes, stain with carmine or picrocarmine and mount in glycerine.

<sup>1</sup> Good specimens are more certainly obtained by the following method. A cat or dog is killed (best by bleeding after chloroform has been given) and warm salt solution is injected into a carotid for a quarter to half an hour, the lymphatic glands of the neck are then cut out and placed in ammonium bichromate 5 p. c. for a few days, sections are cut with a freezing microtome and shaken. In sections so prepared the lymph channels are almost completely free from leucocytes and by careful and more prolonged shaking they may be removed very largely from the follicles and medullary cords.



a. Observe under a low power

- a. The connective-tissue of the **capsule** surrounding the gland and sending in
- $\beta$ . The trabeculæ which divide the outer portion of the gland, the **cortex**, into compartments the **alveoli**, and which then in the inner portion, split up into bands forming a network with rather narrow, elongated meshes, the **medulla** of the gland.
- $\gamma$ . In the alveoli of the cortex the roundish masses of tissue crowded with leucocytes, the **follicles** of the cortex; in the intertrabecular spaces of the medulla the elongated masses of similar tissue the **medullary cords**. Note that the follicles are continuous with the medullary cords.
- $\delta$ . Around the follicles and around the medullary cords and separating them from the trabeculæ the **lymph-channels** comparatively free from leucocytes.

b. Observe under a high power

- a. The connective-tissue of the capsule and trabeculæ (in some animals e.g. ox, this contains unstriped muscular fibres) continuous with
- $\beta$ . The reticulum of the lymph-channels.

- γ. Limiting the follicles and medullary cords may usually be seen a fine line with nuclei at intervals, indicating the flat cells bounding the lymph channel.
- δ. The adenoid tissue of the follicles and cords, with finer fibres and smaller meshes than that of the lymph channels; unless the section has been well shaken this will be largely hidden by leucocytes.

5. Examine sections of glands with the blood-vessels injected.

The arteries enter at the hilus surrounded by connective tissue and branch in the trabeculae of the gland. From the smaller of these branches fine arteries run to the follicles and medullary cords and form in them a capillary network. The veins have a distribution similar to that of the arteries.

## B. SPLEEN.

1. Take the spleen of a cat which has been hardened in ammonium bichromate 5 p. c. and cut out a piece at right angles to the long axis of the spleen. Prepare sections of this with the freezing microtome (cp. Appendix) or if that is not available take a portion of the piece, imbed, and cut by hand. Stain some sections with picrocarmine and mount in glycerine. Observe under a low power

- a.* Externally the broad fibrous sheath, the **capsule** sending in
- b.* Large and conspicuous **trabeculæ**; these run throughout the spleen branching as they go into roundish bundles which are connected with other similar bundles and so form an irregular trabecular network throughout the spleen: the bars of the network cut in all directions will be seen scattered about the section.
- c.* In many of the trabeculæ largish central spaces the **veins**, which may contain blood corpuscles, will be seen, devoid of any proper muscular and connective tissue coats; in the centre of the section large trabeculæ cut transversely or obliquely will probably be seen containing both arteries and veins; if the section passes through the point of entrance of the vessels these will be seen running towards the centre surrounded by tissue continuous with the capsule.
- d.* The **splenic pulp** occupying the spaces of the trabecular network; it resembles somewhat the follicular substance of the lymphatic glands but has a yellowish-mottled appearance, in it will be seen roundish masses of tissue, the **Malpighian corpuscles** more deeply stained than the splenic pulp, the small arteries are surrounded by a variable amount of similar tissue.

- e.* Examine the splenic pulp under a high power and note that the mottled appearance is due to the presence of red blood corpuscles scattered irregularly in it.
2. Prepare a section as thin as possible of a dog's spleen, from which the blood has been washed out by injection with salt solution, and which has subsequently been injected<sup>1</sup> with and then preserved in ammonium bichromate 5 p.c. Stain with dilute picrocarmine shake and mount in glycerine. Observe under a high power.
- a.* There are no distinct lymph-channels.
- b.* The reticulum of the splenic pulp varies in appearance in different places; in places it appears as a network of cells having in various directions flange-like projections which taper off and join with the similar processes of neighbouring cells; elsewhere the cells may be nearly or wholly absent and a reticulum of fine fibres be seen. Some leucocytes

<sup>1</sup> As soon as possible after the animal has been killed (best by bleeding under chloroform) all the branches of the coeliac artery except the splenic branches are tied and warm salt solution is injected into the artery until the spleen is quite pale; then the solution of ammonium bichromate is injected until the spleen is yellow, the splenic veins are then ligatured, the spleen a little distended by further injection and the arteries tied. The spleen is removed to 5 p.c. ammonium bichromate; in two days it is cut in pieces and left in bichromate solution for a week or longer. The pieces are then placed in 30 p.c. alcohol which is renewed until it is no longer coloured, sections may then be made (best with the freezing microtome) or the pieces may be kept in 75 p.c. alcohol.

and red blood corpuscles not washed out of the reticulum will be present.

- c. The reticulum of the Malpighian corpuscles resembles that of the follicles of lymphatic glands, in its meshes are many leucocytes, but no red blood corpuscles.
- d. The small arteries, capillaries and veins of the pulp; the veins branch out from the trabeculæ and have sharp outlines with nuclei at intervals (they may usually be recognized in the dog by the spiral lines running round them).
- e. The trabeculæ are chiefly composed of unstriated muscle tissue (the amount of this varies in different animals, in some it is very small).

3. Prepare a section of spleen injected<sup>1</sup> with Berlin blue from the splenic artery under a low pressure.

<sup>1</sup> A dog is perhaps the best for injection, but a cat or a rat answer the purpose very well. In a dog the individual arteries and veins which run to the spleen are large enough to be easily injected separately, and since the fluid (especially with an arterial injection) does not readily spread out beyond the section of the spleen directly supplied by the vessel, a number of injections may be made in the same animal. The whole spleen should be washed out first from the cœliac artery. To avoid clotting it is advisable to inject 10 p. c. peptone into the jugular before bleeding. The best injection material is a .2 p. c. solution of nitrate of silver, after the injection pieces of the spleen are put in 75 p. c. alcohol for a day or two, then cut with the freezing microtome and exposed to the light. The disappearance of the epithelium of the capillaries and small veins of the splenic pulp show in the clearest manner the opening of these into the spaces of the pulp.

Clear and mount in Canada balsam. Note under a low power

- a.* The small arteries branching off to the Malpighian corpuscles; the artery penetrates the corpuscles usually excentrically, and either divides into a number of capillaries which form a network in the Malpighian corpuscle, or passes on into the pulp giving off a branch which divides into capillaries in the corpuscle.
- b.* Capillaries in the adenoid sheath of the arteries, but less numerous than in the Malpighian corpuscle.
- c.* Small arteries dividing into capillaries in the splenic pulp.
- d.* Small tufts of splenic pulp injected with blue at the ends of the capillaries of the pulp.
- e.* Irregular masses of injected splenic pulp outside the Malpighian corpuscles and adenoid tissue of the arteries where the capillaries open out into the pulp.

If too great a pressure has been used in injecting, instead of the tufts of injected pulp at the end of the capillaries, irregular areas of the pulp or the whole of it will be permeated with the Berlin blue; the Malpighian corpuscles and the adenoid tissue of the arteries will be free from injection unless the pressure used in injecting has been very great.

4. Prepare sections of a spleen injected with Berlin blue from the splenic vein under a low pressure. Observe
  - a. The veins in the trabeculæ filled with injection material.
  - b. The veins of the pulp more or less distinctly branching out from the trabeculæ.
  - c. The irregular masses of injected pulp at the ends of the veins.

If the pressure used in injecting has been high the splenic pulp will be permeated with blue as with an arterial injection under high pressure.

5. Cut across a fresh spleen, preferably one from which the blood has been removed by injecting normal salt solution through the splenic artery, and examine the cut surface with the naked eye. Note the white Malpighian corpuscles. With curved scissors cut out one including some surrounding tissue, and tease it out well in normal salt solution. Observe the large number of leucocytes of very variable size floating about, some not distinguishable from white blood-corpuscles, others twice, others three times as large; in some of the cells scattered about will be seen brownish-red fragments, stages of the breaking down of red blood-corpuscles. Try to make out the constituents of the reticulum (§ 2, b).

## C. LYMPHATIC CAPILLARIES.

The lymphatic trunks need not be noticed, since their structure is essentially the same as that of the veins. (Lesson XII.)

1. From a frog remove the intestines (and if necessary the oviducts) as in Lesson x. E. It will be seen that the peritoneum above and to the outside of the kidney is not adherent to the lumbar muscles, but is separated by a space—the *cisterna magna lymphatica*. Turn the frog over, raise the vertebral column near its end with forceps, cut it through; cut through the abdominal walls parallel to the vertebral column and about half an inch from it, taking care not to injure the underlying peritoneal wall of the *cisterna*; cut through the vertebral column about an inch in front of the first cut; the dorsal surface of the peritoneal cisternal wall will now be seen attached to the kidneys in the median line and to the abdominal walls laterally. Place a ring of cork underneath the kidneys and attached membrane and cut through the abdominal wall close to the edge of the membrane, inserting a hedgehog quill after each cut to keep the membrane flat but not tense. Having thus separated the membrane, stream it gently with salt solution then very briefly with distilled water, immediately after this pour on both sides of it a little nitrate of silver solution 0·5 p.c. (or place it in the solution) and leave it for five to ten minutes. Wash it well with distilled water, and



expose to light. After twenty-four hours, divide it in two pieces, mount them in glycerine, one (*a*) with the peritoneal surface uppermost, the other (*b*) with the cisternal surface uppermost. Observe in (*a*)

*a.* The peritoneal epithelium, consisting of large flat cells with a slightly sinuous outline. This is the usual character of the cells lining serous cavities.

*β.* Where several more or less triangular cells seem to radiate from a common point, note at their apices the small granular nucleated cells surrounding the orifice or **stoma** leading from the peritoneum to the cisterna.

in (*b*)

*a.* The lymphatic epithelium, consisting of flat cells, smaller than the peritoneal epithelium, and with a very irregular sinuous outline.

*β.* The stomata ; very much as in (*a*).

2. Treat with nitrate of silver<sup>1</sup> the peritoneal surface of the diaphragm of a guinea-pig and when stained mount a piece of it with the peritoneal surface uppermost in Canada balsam. Observe

*a.* The tendon bundles of the diaphragm arranged in two layers. The spaces between the

<sup>1</sup> The Student should by this time be sufficiently familiar with the method of using silver nitrate to require no further instructions.

bundles mark for the most part the course of the lymphatic capillaries of the tendon (cp. § 3).

- b.* Superficial to the tendon bundles the epithelium of the peritoneum consisting of flat polygonal cells. These are larger over the tendinous bundles than over the intervening spaces. Stomata similar to those of § 1 *a. β.* may be seen, situated over and communicating with the inter-tendinous spaces. Pseudostomata, irregular patches of staining substance at the junctions of the cells, are frequent.
3. In a guinea-pig or rabbit brush firmly the pleural surface of the diaphragm with a camel-hair brush to remove the surface epithelium and treat with nitrate of silver. Mount in Canada balsam with the pleural surface uppermost.
- a.* The small lymphatic vessels, running a little above the tendinous bundles and lined with somewhat irregular spindle-shaped epithelium. In places the curved outline of a valve may be seen.
- b.* The superficial lymphatic capillaries with their characteristic sinuous epithelium continuous with the lymphatic capillaries of the inter-tendinous spaces.
- c.* The origin of the lymphatics. This is best seen in specimens deeply stained with nitrate of silver, so as to produce the so-called

negative image. Note the clear branched spaces, whose sinuous outline resembles that of an epithelium-cell of a lymphatic capillary. The clear spaces, cavities containing unstained connective-tissue corpuscles, stand out in strong contrast with the surrounding stained matrix. The junction of these spaces with a lymphatic capillary, may here and there be seen.

#### DEMONSTRATION.

The injection of the lymphatics of the testis.  
(Schäfer's *Practical Histology*, p. 216.)

## LESSON XIX.

### STRUCTURE OF LIVER. GLYCOGEN.

#### A. STRUCTURE OF LIVER.

1. Prepare sections of the liver of a frog, snake or bird, treated with 1 p. c. osmic acid and subsequently with alcohol. Mount a section in dilute glycerine. Observe with a low power that the gland apart from the ducts and ductules consists of **anastomosing tubes** between which the blood capillaries run.

Observe with a high power

- a.* The **tubes**. In transverse section they are seen to consist of four to six liver cells, each cell containing a large nucleus usually in its outer portion.
- b.* The **bile capillaries**; these are the lumina of the tubes; in longitudinal sections of the tubes the bile capillaries are seen to take a zigzag course between the inner ends of the cells.

- c. The **cell granules**. According to the condition of the animal from which the liver was taken, these are seen to stretch throughout the cell or to be grouped around the lumen (bile capillary).
  - d. The **fat globules**, stained black with osmic acid, they vary greatly both in number and position according to state of the animal from which the liver was taken.
  - e. The **glycogen** content of the cells. Mount a section in water and run a little strong iodine underneath the cover-slip, the parts of the cell containing glycogen will stain a deep brown-red (cp. B, § 2, a).
2. Prepare sections of a mammalian liver, preferably that of a pig, hardened in Müller's fluid or potassium bichromate 2 p.c. The sections should be made parallel to the surface of the liver. Stain with haematoxylin and mount in glycerine.
- a. Observe with a low power
    - a. The division into **lobules**.
    - $\beta$ . In the centre of most of the lobules the very thin-walled **hepatic or intralobular veinlet**; those in which it is not seen have been cut through near the outer end of the lobule.

- $\gamma$ . Between the lobules the thin-walled **portal** or **interlobular veinlets**, some of them of considerable size; and the **branches** of the **hepatic artery**, small but with comparatively thick walls.
  - $\delta$ . Between the lobules may also be seen small **bile-ducts**, with cubical or columnar epithelium and distinct lumina.
  - $\epsilon$ . The **hepatic cells** radiating more or less obviously from the hepatic veinlet.
- b.* Observe with a high power
- $\alpha$ . The polygonal outline of the hepatic cells; the cell-substance is granular and contains one or more spheroidal nuclei.
  - $\beta$ . The capillary blood-vessels, running out from the centre of the lobule between the rows of cells, and joining with one another at intervals by cross branches; they are usually traceable by their containing blood corpuscles.
  - $\gamma$ . The bile-ducts, their columnar epithelium with distinct nuclei. In some of the sections the epithelium may be seen to become shorter and more cubical as the duct approaches a lobule. The duct itself often appears to end abruptly at the margin of the lobule.

3. Prepare sections of liver, the blood-vessels of which have been injected with Berlin blue or with carmine-gelatine. Clear and mount in Canada balsam. Observe comparing with the uninjected specimens.
  - a. The hepatic veinlet, seen according to the plane in which the lobule is cut, either as a more or less circular section, or as a short veinlet passing from the centre of the lobule to the sub-lobular vein.
  - b. The portal veinlet running on the outside of the lobule.
  - c. The radial capillary network between the portal and hepatic veinlets united by numerous cross branches, commonly there is only one row of cells between the radial capillaries.
  
4. Mount in Canada balsam a section of mammalian liver which has been injected from the bile duct. The bile capillaries will be seen within the lobules as a fine network of minute threads of injected material, passing between and over the *surfaces* of the cells.
  
5. Scrape a small portion of perfectly fresh liver, and observe the pale, granular, hepatic cells, often containing fat globules (cp. § 2, *b, a.*)

## B. GLYCOGEN.

1. Give a rabbit a full meal<sup>1</sup> and about six hours afterwards decapitate it, cut out the liver as rapidly as possible, disregarding the bleeding. Remove the gall-bladder and cut up one half of the liver into small pieces and throw them straightway into about 200 times their bulk of water which is already boiling. (Place the other half in the warm, keeping it moist (cp. § 3).) In about five minutes, when the pieces in the boiling water are all thoroughly coagulated, and the ferment has been destroyed, remove them and pound them in a mortar into a paste with sand; mix this paste with the water previously used, just acidulate with dilute acetic acid (to ensure the complete coagulation of albumin) and boil for a few minutes. Let it stand till the coagulated proteids have settled, and filter the milky fluid through a coarse filter. The sediment may be squeezed in linen, and the expressed fluid thrown on the filter. The opalescent filtrate is a crude infusion of glycogen. The above will afford material for several students.

If it contains *much* proteid material, it should be carefully neutralized, boiled again, and filtered.

2. a. Place a <sup>5</sup>few c. c. of the fluid in a test-tube, and add a drop or two of iodine solution. A port-

<sup>1</sup> The rabbit may be fed on bran and carrots.



wine colour will result which will rapidly disappear if much glycogen is present, if so add more iodine until the colour is permanent. Warm gently; the colour will disappear, but will return on cooling (unless much proteid matter be present).

- b. Test 5 c.c. for sugar with Trommer's test (cp. Lesson xv. D § 7); a small quantity only will be found.
  - c. Add to 10 c.c. (neutralizing if acid) a little saliva, or artificial pancreatic juice, and place it in the warm chamber; the opalescence will disappear, and the fluid become transparent.
    - a. To 5 c.c. of this add iodine as before; the port-wine colour will not appear, showing that glycogen is no longer present.
    - $\beta$ . Test the other 5 c.c. for sugar; much more than before will be found.
3. After some hours' warming, make a decoction of the other half of the liver. It will probably be *acid*, neutralize with sodium carbonate and filter.
- a. The decoction will be clearer, more transparent, and less milky.
  - b. It will give less port-wine colour with iodine.
  - c. It will contain sugar in abundance.

By a *post-mortem* change, glycogen present in the liver at the moment of death, is converted into dextröse.

### DEMONSTRATION.

Artificial Diabetes,

## LESSON XX.

### THE STRUCTURE OF THE LUNG. THE MECHANICS OF RESPIRATION.

1. CUT off the head of a newt. Cut through the skin in the median ventral line of the body, and expose the lungs. Cut across the aorta. Pass a silk thread under the anterior part of one lung and underneath the thread and lung place a small piece of cardboard. Seize with fine scissors a small part of the wall of the lung and snip it with fine pointed scissors, then, pressing a glass cannula somewhat against the underlying cardboard introduce it into the hole made in the lung. Tie the silk thread tightly around the neck of the cannula. With a pipette fill the cannula with 0.5 p.c. gold chloride solution, and pressing it on a small piece of india-rubber tubing which has been previously fitted to the cannula, distend, but not too strongly, the lung; on raising the cannula and alternately pressing and leaving free the indiarubber tube, any air-bubbles which may be in the lung will pass into the cannula. Clamp the tubing in such a way as

to leave the lung fairly distended. Pass another thread under the lung and tie it close below the mouth of the cannula. Holding up the thread cut away the lung from its attachments and place it in gold chloride 0.5 p.c. solution for about fifteen minutes. Then remove it to water, cut it open longitudinally, and get rid of the excess of gold solution by gently shaking the lung in water once or twice renewed. To reduce the gold expose it to light for about 24 hours in water acidulated with acetic acid.

Whilst cutting open the lung note that it is a simple sac with a smooth inner surface.

Mount a piece in glycerine with the inner surface uppermost, and observe with a high power

- a. The **nuclei of the epithelium cells**, occurring in the inter-capillary fossæ in groups of two to four. Sometimes a nucleus may be seen to be surrounded by a small amount of protoplasm coloured violet or red-purple like the nucleus. The cell outlines are rarely to be made out.
  - b. The close capillary network running *between* the nuclear groups. In this will probably be seen blood corpuscles with deeply coloured nuclei. On focussing below the capillaries the long stained nuclei belonging to the coat of unstriated muscular fibres may be seen.
2. Distend the lungs of a frog with 30 p.c. alcohol; ligature each lung at its origin and place one (*a*)

in 30 p.c. alcohol for an hour or more, then in strong spirit for about an hour; leave the other ( $\beta$ ) in 30 p.c. alcohol for two to three days.

Cut open (*a*) and observe

- a.* The large central space.
- b.* The somewhat short primary septa running inwards from the wall of the lung, and forming a number of polygonal chambers open towards the central space.
- c.* Short secondary septa, projecting into the chambers from the primary septa. A lens may be required to see these distinctly.

3. Scrape the inner surface of ( $\beta$ ) and mount in a drop of iodine. Observe with a high power

The isolated epithelium cells, consisting of a thin ground plate having near one border a nucleus with a little surrounding protoplasm stained with iodine.

4. Make transverse sections from the posterior part of a small mammalian trachea, which has been hardened in chromic acid .5 p.c. The section should be so taken as to cut through the ends of a tracheal ring and include the membranous part between them. Observe

- a.* Externally, the **fibrous coat** of loose connective tissue, becoming denser towards the tube of the trachea; in this are embedded the two ends of the ring of **cartilage**.

- b. Stretching between the ends of the cartilage, a **transverse band** of unstriped **muscular fibres**; there may also be visible outside this the cut ends of muscular fibres running longitudinally.
- c. The **submucous coat** continuous with the fibrous coat, but of finer fibres.
- d. The small mucous and serous **glands**, the alveoli of which form a nearly continuous layer in the submucous tissue; the ducts will be less evident, but they may be seen running towards the surface, and occasionally opening on it.
- e. The cut ends of **elastic fibres**, which form a distinct longitudinal layer, on the inner side of the submucous tissue. It will be seen that this is most marked in the membranous part of the trachea; here, too, the fibres are frequently collected into bundles.
- f. The **mucous coat**. In this may be seen
- a. A number of fine elastic fibres with a variable quantity of adenoid tissue.
  - $\beta$ . The distinct basement membrane.
  - $\gamma$ . The epithelium, consisting of long columnar ciliated cells, and of two, three, or more layers of small cells lying between the basal processes of the ciliated cells. If the trachea has not been carefully hardened and prepared, the cilia may

appear only as a granular border lying on the columnar cells. Goblet-cells will probably be seen amongst the ciliated cells.

5. Make longitudinal vertical sections of trachea, taken through the tracheal rings, and compare them with the transverse sections, noting especially the elastic and muscular elements.
6. Take a piece of mammalian lung which has been distended through the trachea with chromic acid .2 p.c., and hardened in the same fluid (the lung of a foetal or new-born animal serves best). The chromic acid having been thoroughly extracted from it by alcohol (cp. p. 69 C, footnote) place it in dilute hæmatoxylin for one to two days so that it is deeply stained. Remove it to 75 p.c. alcohol or to the fluid in which hæmatoxylin is dissolved (cp. Appendix) renewing the alcohol as long as it becomes coloured, then place for ten minutes or longer in strong spirit, and in absolute alcohol. With blotting-paper remove the excess of alcohol and transfer to bergamot oil or oil of cloves for an hour or more. Then remove the excess of oil and let the piece of lung soak for two hours or more in just melted paraffin or in a mixture of spermaceti (1 part) and castor oil (4 parts). Imbed in the same substance and prepare sections, using olive oil to wet the razor; treat the sections with creosote and turpentine and mount then in Canada balsam. Observe

*a.* Sections of blood-vessels (cp. Lesson XII).

*b.* Sections of bronchia. Note that

The sections of the larger bronchia resemble sections of trachea, except that

*a.* The cartilages are irregular in form, and irregularly scattered throughout the fibrous coat.

*β.* The transverse muscular fibres now form a complete ring in the sub-mucous coat.

From the smaller bronchia the cartilages are absent, but the muscular fibres still continue as scattered fibres arranged transversely.

*c.* The passage of a small bronchial tube into an infundibulum (this may be seen occasionally in a section). Note that

*a.* The columnar ciliated cells become shorter and lose their cilia.

*β.* The muscular fibres apparently cease.

*γ.* The longitudinal fibres spread out into an irregular meshwork.

*d.* Sections of alveoli.

*a.* The outline of the alveoli: the distinct basement membrane.

*β.* The flat, tessellated epithelium<sup>1</sup>. This

<sup>1</sup> The outlines of the epithelium cells of the alveoli may be rendered evident by treatment with silver nitrate in the following manner. In a just killed mammal, a cannula is tied in the trachea,



will be seen best where a portion of the wall of the alveolus is left flat in the section; sometimes it may be seen in profile.

- γ. The elastic fibres of the alveolar wall.
- δ. The nuclei and collapsed walls of the capillaries.

7. Take a piece of mammalian lung the blood-vessels of which have been injected. Treat as in § 5 but without staining.

Observe the close-set capillary net-work over the alveolus, and the artery forming a circle round the mouth of each alveolus.

### DEMONSTRATIONS.

1. The circulation in the lung of toad or frog.
2. Tracing on the revolving drum of the movements of the column of air in respiration.

the thorax punctured on each side (or the chest walls removed) and the lungs distended with a .2 p.c. solution of silver nitrate; by alternately forcing the fluid in and drawing it out of the lungs the air will be gradually displaced by the silver solution; when this is the case, 30 p.c. alcohol is several times injected into and drawn out of the lung so that the nitrate of silver is displaced by 30 p.c. alcohol, this is then displaced by 50 p.c., and so on up to strong spirit with which the lungs are distended; the trachea is then tied, the lungs cut out and placed in strong spirit. Sections (best cut with a freezing microtome) are exposed to light and treated as usual.

3. The movements of the diaphragm.
4. Apnœa.
5. Slight dyspnœa.
6. The action of the respiratory muscles in dyspnœa.
7. The collapse of the lungs on puncturing the thorax, and the consequent futility of the respiratory movements.
8. The action of the phrenic nerve.

## LESSON XXI.

### THE COLOUR OF BLOOD. RESPIRATION.

1. POUR a little defibrinated blood<sup>1</sup> into several test-tubes (*a*)—(*d*).
  - a.* Keep for comparison with the rest.
  - b.* Add an equal volume of water and warm to about 50° C.
  - c.* Add a few drops of ether or chloroform and shake.
  - d.* Add a little bile or solution of bile salts and shake.

The blood in (*b*) (*c*) (*d*) will be **laky** i.e. comparatively transparent owing to the hæmoglobin of the corpuscles having been dissolved in the fluid; compare the colour with that of (*a*), compare also the transparency of (*a*) (*c*) by placing a drop of each on a glass slide and attempting to read type through it.

<sup>1</sup> This may be obtained from the butcher's.

2. Place a rat or guinea-pig under a bell-jar with a sponge moistened with chloroform. When it is thoroughly under the influence of the chloroform, quickly open the thorax, and cut across the heart. Collect the blood in a glass beaker, and defibrinate it; pour the defibrinated blood into a platinum crucible surrounded by a mixture of ice and salt. Leave it till it is frozen. Then remove it from the ice and salt, so that it may thaw. By this means the blood-corpuscles will be broken up, and the blood will become laky (cp. § 1). If the blood does not become thoroughly laky it should be frozen and thawed again.

Place the laky blood on one side in a cool place (it is best to surround it with ice) for a day. A sediment will then have formed consisting partly of hæmoglobin crystals<sup>1</sup> and partly of

<sup>1</sup> Blood crystals in quantity may be obtained in one of the following ways:

- a. To defibrinated blood add ether gradually, shaking continuously until the blood becomes laky (the volume of ether required is about  $\frac{1}{4}$  the vol. of the blood taken), place it then in the cool for one to three days. Dog's blood treated thus often yields crystals as soon as it is cooled.
- b. Blood is treated as in § 3, but the washing is repeated many times; to 10 c.c. of the crude solution of hæmoglobin which is obtained add strong spirit drop by drop; shaking continually until a precipitate is obtained, note the amount of spirit added, add this amount of spirit minus .5 c.c. to each 10 c.c. of the rest of the hæmoglobin solution, shaking well as the spirit is added; then place it in a mixture of ice and salt; after some hours to a day decant as much fluid as possible and filter the remainder; the crystals on the filter may be washed with 30 p.c. alcohol and subsequently with water both at 0°C.

broken-up corpuscles. Mount a little of the sediment and examine under a high power. Note

- a. The **crystals of hæmoglobin** (oxyhæmoglobin); those of the rat are thin rhombic prisms; those of the guinea-pig are apparently tetrahedra but in reality belong also to the rhombic system. Look for a clump of crystals to observe better their bright red colour.
- b. The decolorized red blood corpuscles; these will be seen as pale rings mixed up with a good deal of granular débris.

Sometimes defibrinated guinea-pig's blood yields crystals when a drop of it is simply mounted with a drop of chloroform; usually crystals may be obtained without leaving the blood for a day in the cool by placing a little of the frozen blood on a slide, putting on a cover-slip, warming gently over a flame for about half a minute and then cooling; as the blood cools crystals separate out.

3. Let blood (a large quantity is best) clot in a beaker, leave it for a day, then pour off the serum, mince the clot and shake the fragments gently with an equal volume of cold water, place a piece of muslin over the beaker and pour off the fluid; repeat this two or three times, then treat the residue with about three times its volume of water (best at temperature of about

40° C.,) squeezing the pieces; filter through a coarse filter. A crude solution of hæmoglobin is thus obtained.

4. Arrange a spectroscope so that the spectrum of a flame\* and the scale are distinctly seen<sup>1</sup>. Hold in the flame a wire having a few crystals of common salt upon it and observe the bright yellow sodium line (*D*). Shift the scale so that the sodium line is at 58·9 of the scale and clamp the spectroscope tubes.

The numbers on the scale indicate wave-lengths in hundred-thousandths of a millimetre, so that each division corresponds to a difference of a hundred thousandth of a millimetre, and each tenth of a division corresponds to a millionth of a millimetre, in wave-length. The wave-length of the line *D* is 589 millionths of a millimetre, so that when this line is placed at 58·9 of the scale, the wave-lengths of the parts of the spectrum can be read off on the scale<sup>2</sup>.

The spectra described below should be carefully drawn on a blank scale like that of the spectroscope, the position of Fraunhofer's lines *B*, *C*, *D*, *E*, *F* being filled in from the following table

<sup>1</sup> Cp. Gamgee, *Physiol. Chemistry* 1. 93. The Demonstrator will shew the method of using the instrument.

<sup>2</sup> If this scale is not present in the spectroscope used, the position of the sodium should be observed; bring then the micrometer wire exactly over it and read off on the vernier the position of the telescope. In the subsequent observations when the telescope is brought into the position read off, the micrometer wire will give the position of the *D* line.

of the wave-lengths of these lines expressed (roughly) in millionths of a millimetre,  $B = 687$ ,  $C = 657$ ,  $D = 589$ ,  $E = 527$ ,  $F = 486$ . If practicable these lines should be observed in the solar spectrum.

Introduce between the flame and the spectro-scope a much diluted solution of hæmoglobin. Note

- a.* The two absorption bands, both between the lines  $D$  and  $E$ ; the one ( $\alpha$ ) near  $D$  being narrower and darker than the one ( $\beta$ ) near  $E$  (if the solution is very dilute, ( $\alpha$ ) may be the only band seen).
  - b.* The middle of ( $\alpha$ ) is about w. l. 578<sup>1</sup>, that of ( $\beta$ ) about w. l. 540.
5. Increase gradually the strength of the solution.
- a.* The spectrum is more and more cut off both at the blue and at the red end, but especially at the former. The absorption bands are both blacker and broader.
  - b.* As the solution becomes stronger, the two bands run together, the ends of the spectrum also suffering absorption, so that light passes through only in a space in the green (middle about w. l. 507) and a broader space in the red (middle about w. l. 650).
  - c.* With a still stronger solution, the green light

<sup>1</sup> The mid-lines of the bands given here varies somewhat with the strength of the solution.

also is absorbed, and only the red is visible, and this at last disappears.

6. Reduce the oxyhæmoglobin solution with Stokes's reducing<sup>1</sup> fluid in the cold, or with a few drops of ammonium sulphide solution warming gently.
  - a. Compare the claret colour of the **reduced hæmoglobin** solution with the bright scarlet of the original solution.
  - b. Examine with the spectroscope. There is a single broad band, occupying a position intermediate between those of the two oxyhæmoglobin bands which have disappeared. The band is not quite intermediate; its mid-line (w. l. about 565) lies nearer *D* than *E*. This single band is much less dark than either of the two bands produced by the same quantity of oxyhæmoglobin.
  - c. With stronger solutions less of the blue of the spectrum and more of the red (between *C* and *D*) is absorbed than with a solution of oxyhæmoglobin.
7. Shake well the reduced solution, pour it two or three times from one vessel into another so as to expose it thoroughly to air; and examine it at once. The bright scarlet colour will be restored; the oxyhæmoglobin spectrum will reappear. If allowed to remain at rest, reduction, from excess of reducing reagent present, may soon return.

<sup>1</sup> See Appendix.



8. Examine the spectrum of blood-crystals either with the microspectroscope or by placing a thick layer of crystals on a glass slide before the larger spectroscope. The spectrum of oxyhæmoglobin is seen.
9. Pass carbonic oxide through an oxyhæmoglobin solution for fifteen to thirty minutes.
  - a. Note the peculiar bluish tinge acquired. Examine the spectrum; two bands are seen like those of oxyhæmoglobin, but both placed more towards the blue end; the middle of ( $\alpha$ ) is about w. l. 572, of ( $\beta$ ) about w. l. 535. In the absence of a wave-length spectroscope, oxyhæmoglobin and CO-hæmoglobin may be compared as follows. Place some of the oxyhæmoglobin solution before the spectroscope, bring the micrometer wire *to the middle* of one of the bands, and fix the telescope in position. Replace the oxyhæmoglobin solution by the carbonic oxide hæmoglobin solution and examine; the middle of the band will now be to the blue side of the wire.
  - b. Treat the carbonic oxide hæmoglobin with either of the reducing agents used above. Reduction will not take place.
10. Take a few c.c. of a solution of crystals of hæmoglobin.
  - a. Boil; the proteid constituent will be coagulated.

- b. Add drop by drop HCl 1 p.c., the hæmoglobin will be split up and the proteid constituent precipitated; add an equal bulk of ether and shake, the colouring matter (hæmätin) will be largely dissolved in the acid-ether; with a pipette remove the lower stratum of fluid, add a few drops more acid and place at about 40° C., the proteid precipitate will be converted into acid-albumin and dissolved; neutralize, it will be precipitated and may be examined for the ordinary characters of acid-albumin.
11. Place a drop of blood on a glass slide, and by *gently* warming evaporate it to dryness: add to it a grain of salt, and thoroughly mix it with the blood, rubbing the whole to a fine powder. Cover with a cover-slip, and let a little *glacial* acetic acid run under it. Warm the slide, not too rapidly, over a flame till bubbles appear under the cover-slip; then let it cool, and examine under a microscope with a high power. A large number of **crystals** of **hæmin** as brown-red rhombic prisms will be seen.

### DEMONSTRATIONS.

1. The spectra of
  - a. Hæmätin in acid and alkaline solutions.
  - b. Hæmätin reduced in an alkaline solution.
2. The gases of the blood.

3. The colour of venous and arterial blood in the living animal, and its dependence on the presence of oxygen in the lungs.
4. The respiratory function of the pneumogastric.
5. The action of the respiratory centre.
6. The effect of arterial and venous blood on the irritability of muscular tissue.
7. The phenomena of asphyxia.

## LESSON XXII.

### STRUCTURE OF THE KIDNEY.

1.
  - a. Take a sheep's kidney and cut it in half longitudinally, note the **ureter** expanding into the **pelvis** and then into several tubes, the **calices**, into which the pyramids project.
  - b. On the cut surface of the kidney, note the pale inner or central **medulla** formed by the pyramids of Malpighi ; externally the **cortex** a brownish-red zone having thin pale radial stripes (cp. § 2, c) which do not quite reach the surface ; and between the medulla and cortex the **intermediate layer** forming a dark red zone not very sharply defined, especially on the cortex side, and having pale stripes (cp. § 2, b) continuous with those seen in the cortex running radially through it from the medulla.
  - c. Turning back to the ureter, note the connection of its outer connective tissue coat with the fibrous coat of the kidney, follow the renal artery and vein running into the kidney in

the connective tissue outside the ureter and pelvis; both artery and vein divide into several branches which enter the substance of the kidney outside and between the ends of the calices at the bases of the pyramids; tracing them outwards they will be seen to run to the outer portion of the intermediate-layer and there to branch, their branches arching through the kidney substance and so forming a net-work (more complete in the veins than in the arteries) stretching through the kidney substance in the curved surface of the outer part of the intermediate-layer.

2. From a mammalian kidney hardened in ammonium bichromate 5 p.c. prepare radial sections extending from the outer surface to the summit of a papilla. The sections are best cut with a microtome. Stain them. Observe under a low power.
  - a. The **medulla**, with its straight tubes; some of the numerous divisions of these as they run outwards may be seen.
  - b. The **intermediate layer**: the straight tubes of the Malpighian pyramids separate into bundles the **medullary rays** (pyramids of Ferrein); between the bundles are seen numerous blood-vessels and some tubes of Henle (cp. § 3, b).
  - c. The **cortex**: the medullary rays are seen to run out nearly to the free surface, between

these are convoluted tubes and end-capsules with their glomeruli arranged in double rows between each two pyramids (the symmetrical arrangement of the medullary rays and intervening convoluted tubes may not be obvious if the section is cut obliquely). In the outer part of the cortex convoluted tubes only are seen.

3. Observe under a high power.

a. In the medulla

a. The epithelium of the **straight tubes** (tubuli uriniferi recti); in the smaller tubes, collecting tubes, this is composed of short columnar or cubical cells with spherical or ovoid nuclei; in the larger tubes, outflow tubes, it is composed of longer columnar cells with ovoid nuclei; the lumina, distinct throughout, become larger as the tubes increase in size.

b. In the intermediate layer

a. The continuation of the straight tubes outwards in the medullary rays.

β. The loops of Henle, chiefly in the medullary rays; they run down also a variable distance into the medulla.

γ. The **ascending limbs** of the loops; these will probably be deeply stained, they vary in size in different parts of their course and are composed of cells

sometimes imbricated, with striated outer portions and containing oval nuclei; the lumen is small.

- δ. The **descending limbs** of the loops; these are much narrower, with transparent flattened epithelium the nuclei of which project into the lumen, sometimes alternately on the two sides, and thus the tube, except for its basement membrane, simulates a blood capillary.

The change in character of the epithelium may take place either in the ascending or in the descending limb of the loop.

- ε. The numerous blood-vessels between the medullary rays (cp. § 8, *b*); in the outer part of the layer rather large arteries and veins cut transversely or obliquely will be seen (cp. § 1, *c*).

c. In the cortex

- a.* The **end-capsules**, with the nuclei of their epithelium.
- β.* The **glomerulus** in each end-capsule (cp. § 8, *c*) and the nuclei of its capillaries.
- γ.* The narrow neck of the capsule, this will be obvious in those capsules only in which the section has passed longitudinally through the neck.
- δ. The coiled course of the **convoluted tubes** (tubuli contorti); the outlines of

the individual cells may or may not be distinct, they have each a spherical nucleus and are striated in their outer portions. Sometimes the lumen is large, sometimes it can scarcely be made out.

- ε. The continuation outwards in the medullary rays of the ascending loop of Henle.
- ζ. In the outer half of the cortex are deeply stained short tubules running out from the rays and sometimes seen to be continuous with the ascending loops of Henle; their cells resemble those of the ascending loop except that they are of unequal size, thus giving a very zigzag outline to the tubule; this is the '*irregular*' portion of the urinary tubule.
- η. In the medullary rays will also be seen one or two rather large tubes with conspicuous spherical nuclei, these are the so-called *spiral tubules*. Note also in the rays the smaller straight (collecting) tubes.

A basement membrane may be made out in all portions of the urinary tubule.

4. Cut sections at right angles to the medullary rays through the lower part of the cortex and observe the medullary rays surrounded by convoluted tubes.



5. Cut similar sections through the outer part of the medulla and observe the cross sections of the tubes, and their *membrana propria*, with a small amount of connective tissue between them; sections of both the ascending and descending limb of the loops of Henle will also be seen.
6. Place a small piece of the cortex of a fresh kidney in 5 p.c. neutral ammonium chromate, tease out a fragment in the same fluid. Observe the cells of the convoluted tubes, isolated or in groups, shewing a very distinct striated outer portion; in some cells the outer part may appear as a brush of 'rods.'
7. Cut as thin a section as possible of the inner part of the cortex of a fresh kidney, tease it out in normal salt solution and observe the appearance of the fresh cells in the isolated bits of tubules.
8. Take a piece of kidney which has been injected from the renal artery, prepare sections like those of (§ 2), clear and mount in Canada balsam. Observe
  - a. The large arteries and veins in the upper part of the intermediate layer.
  - b. The small arteries and veins (**arteriæ et venæ rectæ**) given off from these, running down between the medullary rays into the medulla; they break up almost immediately into a brush of capillaries which enter the

medulla and form a network throughout it; the meshes are elongated in the direction of the tubes, especially near the summit of the papilla.

- c. The **interlobular arteries** and **veins** running from the larger vessels outwards in the cortex between the medullary rays; the arteries give off on all sides (two rows will probably be seen in the section) small arteries (*arteriæ afferentes*), one to each end-capsule where it breaks up into capillaries to form the glomerulus.
- d. The small vein (*vena efferens*) issuing from each end-capsule and breaking up into capillaries which form a network in the cortex; the veins from the innermost capsules break up into a brush of capillaries like the *arteriæ rectæ* and run towards the medulla.
- e. The small veins running from the capillary network of the cortex to the interlobular veins (§ c).
- f. Here and there the small artery running to a glomerulus may be seen to send a branch direct to the capillary network of the cortex; similar direct branches will also be seen in the outer part of the cortex running from the ends of the interlobular arteries.
- g. Small veins at the periphery of the cortex (*venæ stellatæ*) also arising from the capillaries of the cortex.

9. Cut vertical sections of a rabbit's or dog's **bladder** which has been distended with and hardened in ammonium bichromate 2 p.c. Observe
- a. The thin external fibrous coat.
  - b. The muscular coat consisting of an outer generally speaking longitudinal layer and an inner generally speaking circular layer; inside this may also be seen a third layer with fibres running in various directions chiefly longitudinally.
  - c. The sub-mucous coat of connective tissue.
  - d. The mucous coat of
    - a. Connective tissue rather finer but continuous with that of the sub-mucous coat.
    - $\beta$ . Epithelium consisting of an inner layer (next to the cavity of the bladder) of a single row of roughly cubical cells, a median layer of a single row of pear-shaped cells, and an outer layer (next the basement membrane) of two or three rows of elongated cells between and beneath the processes of the pear-shaped cells.
- The form of the cells naturally varies with the degree of distension of the bladder.
10. Cut transverse sections of a rabbit's or dog's ureter which has distended and hardened like the bladder (§ 9).

Apart from the thickness of the coats, the structure is much the same as in the bladder.

#### DEMONSTRATION.

Nitrate of silver preparation to shew the epithelium of the end-capsules.

## LESSON XXIII.

### URINE.

1. DETERMINE the specific gravity of urine by means of the urinometer.
2. Test the reaction of fresh urine with litmus paper, it will be **acid**; this is due to the presence of acid salts mainly of acid sodium phosphate, and *not* to free acid.
3. Put 200 c.c. of urine in a warm place, and observe from time to time.
  - a. It will, after twenty-four or more hours, lose its acid reaction, and become alkaline. Gently warm the litmus paper turned blue by the urine, the blue colour will disappear, shewing that the alkalinity is due to the presence of ammonia or a salt of ammonium.
  - b. It will gradually become cloudy, and yield a deposit of various salts.
  - c. Its odour will become putrefactive.

The urine has undergone **alkaline fermentation**.

4. A small quantity of **mucus** derived from the urinary passages is occasionally present in the form of a faint cloudy precipitate. This may be rendered more apparent by the addition of acetic acid.
5. **Urea.** Place a few crystals of urea in a watch-glass, and dissolve them in a small quantity of water.
  - a. Mount a drop of the solution, and when it has partially evaporated observe under a high power the *crystals of urea*, consisting of four-sided prisms<sup>1</sup> commonly ending in two surfaces or in a single oblique surface; if the evaporation is rapid the urea crystallises in long spicules.
  - b. Add to another drop on a slide a drop of pure, fairly strong, nitric acid; observe under the microscope the rhombic and six-sided tablets of *nitrate of urea* which crystallise out. Note the striæ frequently present in these tablets.
  - c. Repeat (b), using a concentrated solution of oxalic acid instead of nitric acid. *Oxalate of urea* will crystallise out in various forms, prominent among which will probably be long thin flat crystals often in bundles; regular rhombic prisms, or tablets resembling

<sup>1</sup> Figures of the crystals described in this Lesson will be hung in the laboratory.

somewhat those of nitrate of urea, may also be seen.

- d.* Dilute considerably the remaining solution, and add to a part of it a solution of mercuric nitrate. A white precipitate of mercuric oxide combined with urea will at once take place.
  - e.* To the rest of the urea solution add a little sodium chloride and then mercuric nitrate drop by drop. A certain quantity of the mercuric nitrate must be added before any precipitate is formed; a double decomposition takes place between the mercuric and sodium salts so that as long as any sodium chloride is present, the mercuric nitrate is not available for precipitating the urea.
  - f.* Place a little urea in a test-tube and heat it carefully over a flame, when the temperature is somewhat over 100° C. it melts and ammonia is given off (recognized by its odour), heat it a little longer then let cool; add a small quantity of water to dissolve the residue and pour the fluid into another test-tube containing a strong solution of sodium hydrate and a drop or two of cupric sulphate. A violet colour will be produced (*biuret reaction*).
6. Evaporate 20 c.c. of urine in a water-bath till its volume is reduced to about 2 c.c. Filter, and examine the filtrate for urea (§ 5, *b. c.*).

7. **Uric Acid.**

- a. Place a few crystals of uric acid on a slide, and add a little liquor potassæ to dissolve them; then add nitric acid just to excess. Examine with a high power the crystals of uric acid formed. They are generally rhombic plates with obtuse angles, but they vary greatly in form. Note the star-shaped and dumb-bell crystals.
  - b. Make a saturated solution of uric acid in strong sodium hydrate, mount a drop and place it aside for some time. Crystals of sodium urate will crystallise out. Note the spheres covered with small thin projecting prisms; hexagonal prisms and thick tablets may also be seen.
  - c. To a little uric acid in an evaporating dish add a little fairly strong nitric acid, the uric acid will be split up and gases given off. Evaporate to dryness on a water-bath at a temperature not above 40° C. A reddish residue will be left, to this add a drop or two of *weak* ammonia; a red-purple colour will be formed; this is the **murexide test** for uric acid. Add then a drop of strong sodium or potassium hydrate, the colour will turn to a blue-purple.
8. To 100 c.c. of urine (best evaporated to a third of its bulk) add about 1 c.c. of pure strong hydrochloric acid. Place aside for a day or two



in a tall glass jar. Brownish red crystals of uric acid will form at the sides and bottom of the jar. Examine one or two of these under the microscope, to the rest apply the murexide test (§ 7. c).

## TESTS FOR SOME ABNORMAL CONSTITUENTS OF THE URINE.

### 9. **Albumin.**

a. Boil, making the fluid just acid with acetic acid; albumin if present is coagulated (cp. Lesson III. § 17).

b. Apply also the tests for proteids.

10. **Sugar.** Coagulate any albumin that may be present (cp. § 9) and filter; apply Trommer's test<sup>1</sup> (Lesson xv. D § 7).

The colouring matter of the urine may be removed by pouring it on a filter containing some animal charcoal moistened with water; it must be remembered however that if the quantity of sugar present is small it may be retained by the charcoal.

11. **Bile Pigment.** Use Gmelin's test (Lesson xvii. B, § 3).

<sup>1</sup> If a faint reaction only is obtained, it cannot be relied on as shewing the presence of sugar, since several other bodies (*e.g.* uric acid) which occur in urine also reduce cupric oxide.

12. **Bile-acids.** Use Pettenkofer's test (Lesson XVII. B, § 4).

Or—Soak a small piece of white blotting paper in a syrup of sugar, and allow it to dry. Let fall on it a drop of the urine supposed to contain bile-acids, and near it a drop of strong sulphuric acid, so that the two drops run into one another. If bile-acids are present, there will be a purple colouration at the junction of the drops. If the quantity of bile-acids present is small, the urine must be concentrated, but in such cases it is best to test in the ordinary way.

#### QUANTITATIVE ESTIMATION OF UREA.

1. **Knop-Hüfner Method.** (*Hypobromite Method.*)

When sodium hypobromite in an excess of alkali is added to a urea solution nitrogen is given off, thus,

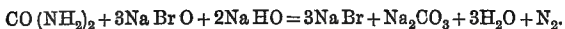

According to this equation 1 gram of urea gives off very nearly 373 c.c. of nitrogen. In fact, however, the decomposition of urea is not complete, the amount of the deficit depends chiefly upon the amount and strength of the hypobromite solution, and on the percentage of urea in the urea solution. In making an accurate estimation of urea, the deficit of nitrogen under the conditions of the observation, (determined beforehand) must be allowed for; and as the theoretical amount of nitrogen is estimated at a temperature of 0° C. and a pressure of 760 mm. of mercury, the volume of

the gas obtained must be corrected for this temperature and pressure (cf. p. 402).

When, as in medical practice, a rough estimation of the percentage of urea is sufficient, the tube in which the nitrogen is collected is graduated empirically, at the ordinary indoor temperature, i.e. at about 18° C. The graduation is performed by mixing a known quantity of hypobromite solution with 5 c.c. of a 1 p.c. solution of pure urea, and marking on the collecting tube the volume of nitrogen given off. Similar observations are made with 5 c.c. of a 2 p.c. and of a 3 p.c. solution of urea. The tube, between each of the marks so obtained, is divided into tenths. Hence, when 5 c.c. of a solution of urea of unknown strength are taken, and treated as the standard solution was treated, the percentage of urea in it is at once roughly determined by the number of divisions of the tube occupied by the nitrogen given off.

One form of apparatus of this kind is described in the Appendix (cf. p. 400).

## 2. **Liebig's Method.** (See p. 398.)

### QUANTITATIVE ESTIMATION OF SUGAR.

Fehling's fluid (cf. p. 381) contains a known amount of cupric sulphate, and this, as has been seen in using Trommer's test, is reduced by sugar to cuprous hydroxide or oxide when boiled with it in an alkaline solution. In making an estimation, 10 c.c. of

Fehling's fluid may conveniently be taken, the cupric salt in this is just reduced by  $\cdot 05$  gram of sugar.

*Preliminary estimation.* Take 20 c.c. of urine, dilute it to 100 c.c. with water, and put the diluted urine in a burette. Into a small porcelain dish, measure accurately 10 c.c. of Fehling's fluid, add about 10 c.c. of sodium hydrate and 30 c.c. of water; place this on a piece of wire gauze over a small Bunsen burner to boil, as soon as it boils run in the urine from the burette in such amount that the fluid does not cease to boil, and stir continuously. When the fluid undergoes a distinct change of colour, the urine should be added more slowly, and as soon as the fluid turns bright yellow or brick red, the amount of urine added ( $a$  c.c.) should be noted.

*Second estimation.* The Fehling's fluid is measured out and diluted as before,  $a - \cdot 5$  c.c. of diluted urine run into it and the mixture boiled. It is then put aside to allow the precipitate to partially settle; as soon as there is a sufficient fluid free from precipitate, the colour of the fluid should be noted. If it is still blue,  $\cdot 1$  c.c. urine is added, the mixture again boiled, the colour of the fluid noted, and so on until the fluid is no longer blue. If the fluid is colourless after adding  $a - 5$  c.c. of diluted urine; a fresh portion of Fehling's fluid must be measured out  $a - 1$  c.c. of diluted urine added and the process given above repeated. This ought not

to be necessary for the preliminary estimation should give the amount within .5 c.c. If  $b$  be the number of c.c. of diluted urine required to reduce the 10 c.c. of Fehling the percentage of sugar in the urine will be  $\frac{.05 \times 5 \times 100}{b} = \frac{25}{b}$ .

There are certain sources of error in the method given above. (1) When the mixture is boiled, a little ammonia is set free from some of the constituents of the urine, this dissolves some of the precipitated cuprous oxide; the cuprous oxide takes up oxygen from the air and a cupric salt is formed giving a blue tinge to the solution. The re-oxidation of the precipitated oxide may be lessened by boiling in a small glass flask instead of in an open porcelain dish, but since the former is more easily cracked during boiling, and in it the colour of the fluid is less readily seen, it is not recommended for the beginner. (2) When the diluted urine contains more than 1 p.c. or less than .5 p.c. of sugar, the method is inaccurate; since 5 c.c. of a 1 p.c. solution of sugar, or 10 c.c. of a .5 p.c. solution contain .05 gram of sugar, i.e. will reduce 10 c.c. of Fehling's fluid, the urine, for an accurate estimation, must be diluted to such an extent that not more than 10 and not less than 5 c.c. of the diluted urine are required to reduce 10 c.c. of Fehling's fluid. The Fehling's fluid is diluted 5 times because with either a greater or a less dilution the results are inaccurate.

## LESSON XXIV.

### SKIN AND TOUCH.

#### A. SKIN.

1. Prepare vertical sections of human scalp which has been hardened by placing it in chromic acid ·2 p.c. for a week. Stain the sections with picocarmine, mount them in glycerine and observe
- A. The **Epidermis**: proceeding from the outside will be seen
  - a. Non-nucleated cells, the cell substance of which is no longer protoplasmic but has become transformed into horny keratinous material; they are much flattened especially near the surface of the skin, where they may present the appearance of a number of fibres. This is the **horny layer**; in the stained sections it will be yellow.
  - b. Nucleated cells, spheroidal in form: the peripheral part of these cells may appear striated or closely serrated (the expression of fine projections of the surface).

- c. A row of columnar nucleated cells placed perpendicularly to the tissue beneath. The spheroidal and the columnar cells together form the **Malpighian layer**.

*B.* The **Dermis** : in which may be seen

- a. A thin outer layer consisting of a fine plexus of white fibrous tissue, of connective tissue corpuscles, and of some anastomosing elastic fibrils, embedded in a good deal of hyaline or faintly fibrillated matrix. The upper portions of this form a kind of basement or limiting membrane immediately below the columnar epidermic cells. The lower portions pass gradually into
- b. A plexus of fibrous tissue with larger bands and a more developed elastic-fibre network ; in its deeper portion this merges into the **sub-cutaneous connective tissue** in which the spaces of the plexus are large and in which clumps of fat cells usually occur ; there is no definite line of demarcation between the dermis and the sub-cutaneous tissue.
- c. The **papillæ** : conical elevations of the dermis, rising up into the Malpighian layer, which therefore appears to dip down between them.
- d. Indications of the blood-vessels, abundantly distributed all over the dermis, and forming capillary loops in the papillæ. They should be observed in injected specimens.

- e.* In the lower part of the dermis bundles of nerves which, as they run to the upper part of the dermis, split up into smaller bundles and form a plexus; from this run still smaller bundles to form a more superficial closer meshed plexus; probably the latter will not be very obvious in this specimen.
- f.* **Hair-follicles** and the roots of hairs. Note
- a.* The outer sheath of the follicle formed of fibrous tissue continuous with that of the dermis, but much denser in arrangement.
  - β.* The inner sheath of the follicle, consisting for the most part of indistinct transversely arranged fibres, amongst which oblong nuclei may be discerned.
  - γ.* A hyaline limiting membrane more marked than that of the dermis.
  - δ.* The outer root-sheath, consisting of cells continuous with, and resembling those of the Malpighian layer.
  - ε.* The inner root-sheath, pale and transparent, its inner part consists of small nucleated cells, near the bulb its cells become larger. This sheath is absent above the duct of the sebaceous gland. At the exit of the hair from the skin the horny layer dips down around it in the form of a cone.



- ζ. The hair-bulb or the enlargement of the hair in its deepest part, consisting of a layer of nucleated cells continuous with the outer root-sheath; the outer root-sheath near this point is much diminished in breadth.
- η. The papilla of the follicle projecting into the hair-bulb, it consists of connective tissue like that of the outer layer of the dermis with which it is continuous.
- θ. The substance of the hair consisting of a cuticle of thin horny scales in a single layer, and internally of long horny fibres or in its deeper portion of spindle shaped cells.
- h. The **sebaceous gland** or glands opening into the upper part of the hair follicle; in the body of the gland the cells are several layers deep; they are continuous with the cells of the outer root-sheath.
- i. A little below the opening of the gland into the follicle may be seen a band of plain muscular fibres, stretching obliquely from the inner sheath of the follicle to the upper part of the dermis.
2. Cut sections of the palm of the hand or of the forehead<sup>1</sup>, hardened in chromic acid, picric acid,

<sup>1</sup> Instead of this a piece of the skin of the ball of the foot of a cat may be taken.

or alcohol, to observe the structure of the **sweat-glands**. Note

- a. The terminal gland-coil in the outer part of the subcutaneous tissue, with its membrana propria continuous with that of the dermis, and lined by a single layer of cubical or short columnar cells.
  - b. The gland-duct having two or three layers of cells continuous with those of the Malpighian layer of the epidermis. The lumen is usually distinct in both duct and coil. In the epidermis the cells proper to the duct cease but its lumen is continued on in a spiral course to the surface surrounded by concentrically arranged epidermic cells.
3. In the specimen of the cornea of the frog prepared as in Lesson v. B § 2 (cp. also Lesson x. C § 2) observe
- a. The **primary nerve-plexus** formed by the bundles of nerves which enter the cornea at its periphery; this plexus has in its deeper part rather large meshes and its fibres have nuclei on their course; towards the surface, and especially just beneath the anterior basement membrane, this plexus becomes much finer consisting chiefly of small bundles of nerve-fibres with much less frequent nuclei; when these occur they are usually at the nodal points of the plexus.

4. Cut out the cornea of a recently killed cat or rabbit, taking care not to drag it, and place it in gold chloride .5 to 1 p.c. for an hour. Wash well and expose to light as usual, but do not remove its epithelium. When it is well stained, if necessary harden with alcohol, imbed a piece of it vertically in paraffin, and cut sections as thin as possible. Observe
  - a. The bars of the primary plexus cut across, and becoming finer and more numerous towards the anterior membrane; from this superficial layer of the plexus single axis cylinders or small bundles of fibrils (rami perforantes) run through the anterior membrane and separate into a brush of fine varicose fibrils which spread out immediately underneath the epithelial cells forming the **sub-epithelial plexus**. Probably the section in some part will be a trifle oblique, here a fragment of the sub-epithelial plexus will be seen having small meshes and very fine varicose nerve fibrils, elsewhere similar fine fibrils will be seen running a longer or shorter course underneath the cells. (To see the sub-epithelial plexus well, sections should be cut from the surface of the cornea and a section which includes the anterior surface of the basement membrane picked out.)
  - b. Between the epithelial cells of the cornea, the **epithelial plexus** of very fine varicose

nerve fibrils; in places the fibrils will be seen to run from the sub-epithelial plexus.

The peripheral course of the nerve-fibres in the parts of the skin where there are no special terminal organs, is in the main like that described above for the cornea.

5. Cut sections of the skin of the tip of a finger which has been placed fresh in osmic acid 1 p.c. and subsequently treated with alcohol. Mount the sections in dilute glycerine. Observe the **touch-corpuscles**.

a. They are oval in form, and are found in the axes of the papillæ; many papillæ are without them, in which case a capillary may generally be seen running up into the papilla.

b. They appear to consist of a mass of connective tissue in which nuclei are disposed transversely.

c. The nerve-fibre reaches it near the base, and may be traced coiling round it spirally for a variable distance.

Pacinian bodies (cp. § 6) may be seen in the subcutaneous tissue.

The touch-corpuscles are also obvious in sections of skin hardened in potassium bichromate 1 p.c. but the course of the nerve fibre is less easily traced.

6. Examine the mesentery in a recently killed cat; in it will be seen a considerable number of oval transparent bodies the **Pacinian bodies**. Select

one which is not surrounded by fat, cut it out and mount it in normal saline solution. With a little care the mesentery covering it may be removed with needles. Observe

- a. The medullated nerve-fibre and the thickening of its connective-tissue sheath as it approaches the Pacinian body.
- b. The division of the connective-tissue sheath to form the numerous concentric capsules, which become closer together towards the centre. At intervals on the capsules elongated nuclei will be seen.
- c. The loss of medulla as the sheath splits up.
- d. The hyaline core inside the innermost capsule.
- e. The axis-cylinder penetrating the core, and ending in it in a slight enlargement.

To observe the manner in which a small bundle of nerve fibres separate and run to the Pacinian bodies, a piece of the mesentery containing a number of them should be stretched over a slide, the piece cut out and the edges allowed to dry, so that the part containing the Pacinian bodies is kept stretched. The outlines of the flat cells of the capsules can easily be made obvious by placing a Pacinian body freed from the mesentery as in § 6 in .5 p.c. nitrate of silver for a quarter of an hour, then exposing to light as usual and mounting in water. They are not easy to preserve, the best plan is perhaps to irrigate with dilute glycerine after treatment with osmic acid or gold chloride.

## B. TOUCH.

1. **Power of localisation.**

Using a pair of small bone or wooden compasses, determine the distance at which the points must be placed from each other in order that they may be felt as two points when applied lightly and with the same force to various parts of the body. Try if the following order is correct: tip of tongue, tips of fingers, palm of hand, cheeks, back of hand, fore-head, front of fore-arm, back of fore-arm, back of neck, &c.

2. **Sensation of temperature.**

Dip a small metallic knob in hot water (*e.g.* 70° C.), and applying it to the same parts of the body as before, determine roughly the sensitiveness to temperature of these parts.

3. **Estimation of weight. The muscular sense.**

- a.* Determine the smallest difference in weight which can be appreciated when slightly differing weights are held in the palm of the hand.
- b.* Then laying the hand and arm supine on a table, so that they are motionless, and placing weights on the palm of hand, determine as before the difference of weight which can be appreciated. This will be much less in the case of (*b*) than of (*a*). In (*a*) the muscular sense is employed; in (*b*), only the sensation

of pressure. The weight should be placed on the same part of the palm of the hand in each case.

4. Estimate (in either way) the difference of weight which can be appreciated
  - $\alpha$ . When the weights are light, *e.g.* 1, 2, 3, 4, or 5 grms.
  - $\beta$ . When the weights are heavy, *e.g.* 10, 20, 30, &c., or 100, 200, &c. grms.

Smaller differences will be appreciated in  $\alpha$  than in  $\beta$ . In fact the difference of weight which can be appreciated bears, roughly speaking, a constant ratio to the whole weight.

5. Plunge the finger into mercury, and then draw it out. The sensation will be that of a ring passing down and up the finger, the greatest sensation being where there is the greatest variation of pressure.
6. Place two equal light weights, one cold the other warm, on the corresponding fingers of the hands; the cold one will feel the heavier.
7. Paint a ring of collodion on the palm of the hand, leaving only a small central space, and attempt to distinguish between the approach of a hot body and gentle contact of a feather.
8. Place the elbow first in warm water, and then in a mixture of ice and water. There will be a sensation of pain in the fingers and cold in the

elbow. The application of cold to the *trunk* of a nerve does not cause a sensation of cold.

9. **Tactile delusions.**

Cross the second finger over the first or the third over the second, and place between their tips a small marble (or any solid round body a little larger than a pea) so that it touches the radial side of the first, and the ulnar side of the second finger-tip. On gently rolling the body about, a sensation as if of two distinct bodies will be felt.

The same delusion is experienced if the tip of the nose be gently rubbed with the tips of the fingers so placed.

Experiments 6 and 7 will need the assistance of a second person.



## LESSON XXV.

### TASTE AND SMELL.

#### A. ORGANS OF TASTE AND SMELL.

1. Cut off the head of a newt<sup>1</sup>, remove the lower jaw, cut off the nose by an incision carried just in front of the eyes, with a fine pair of scissors remove the roof of the nasal cavities, and place the remainder of the nose in osmic acid 1 p.c. for 2 to 24 hours as convenient. Tease out in water a small piece of the mucous membrane. Or place the nose in Müller's fluid for a week, and tease out the mucous membrane in the same fluid or in water. Observe
  - a. The **cylindrical** epithelium **cell**, its large oval nucleus, its broad, clear, peripheral process, and its branching, faintly granular, central process.
  - b. The **rod-cell**, (olfactory cell) with its spheri-

<sup>1</sup> Instead of this the nasal mucous membrane of a mammal may be taken, it is best to take it with the underlying bone or cartilage attached (cp. p. 30, § 22).

cal nucleus, its hyaline slender peripheral, and its still more slender varicose and branching central process.

- c. Cylindrical cells will frequently be seen, surrounded and partially hidden by three, four or more rod-cells.
- 
2. Take the nose of a freshly-killed newt<sup>1</sup> as in § 1, but instead of laying bare the olfactory chambers, cut off the tip of the nose. Place it in chromic acid .3 p.c. for a week. If the salts of the bone are not completely dissolved, complete the solution with nitric acid 1 p.c. mixed with an equal volume of spirit. Imbed it vertically, and cut transverse sections. Stain and mount one of the first sections (*a*) and one of the last sections (*b*). Observe
    - a. In the respiratory portion of the mucous membrane
      - a. That the surface-epithelium consists of columnar ciliated cells, interspersed with goblet-cells. Between the deeper portions of these cells and close to the basement membrane, some small cells will be seen (these with or without division develop into the surface cells).
      - $\beta$ . In the sub-mucous tissue, serous and mucous racemose glands.

<sup>1</sup> Cp. footnote on p. 257.

- b.* In the olfactory part of the mucous membrane, the division of the epithelium into an outer and an inner layer.

  - a.* The outer layer consisting of the peripheral processes of both cylindrical and rod-cells.
  - β.* The inner or nuclear layer consisting of several rows of nuclei belonging to the rod-cells. The nuclei of the cylindrical cells form a single row in the upper part of this layer, but these, as well as the greater part of the processes of the rod-cells, are generally hidden by the nuclei of the rod-cells.
  - γ.* In the sub-mucous tissue the numerous bundles of the non-medullated nerve-fibres of the olfactory nerve. Near the epithelium these form a close-meshed plexus.
  - δ.* Serous glands, usually tubular with a few branches; here and there a duct may be seen running through the epithelial layer as a fine tube consisting of basement membrane and flattened cells.
3. From a rabbit's tongue which has been hardened in chromic acid .2 p.c., or in potassium bichromate 1 p.c., excise a papilla foliata (cp. p. 32, § 29) and imbed in such a way that the sections will be at right angles to the ridges.

Prepare thin vertical sections and observe

- a.* The section of the ridges with the intervening fossæ.
- b.* In each ridge three papilliform processes of the dermis, one median, two lateral.
- c.* The horny epidermis, consisting of cells very flattened, but still retaining their nuclei, covering the ridges and lining the fossæ.
- d.* The Malpighian layer of the epidermis underneath the horny layer. In the fossæ both layers of the epidermis are thinner and less marked off from one another than on the surface.
- e.* On the outside of each lateral papilla, and therefore lining each side of the fossa, the flask-shaped **taste-buds**<sup>1</sup>. There are usually four nearly in contact one above the other.
- f.* Each bud is in contact by its deeper part with the dermis of the papilla, and has a short neck running to the free surface of the epidermis of the fossa where its circular open mouth may often be seen.
- g.* The epidermic cells are flattened around its median portion, forming a nest for it.
- h.* The bud itself, with
  - a.* The external **cover-cells**, curved and flattened, with conspicuous oval nuclei.

<sup>1</sup> Taste-buds in fungiform papillæ may be seen in sections of the tip of the tongue of the cat.

- $\beta$ . The **rod-cells**, (taste-cells) with spherical or ovoid nucleus, rod-shaped hyaline peripheral and central processes.
- i*. Nerve fibres running along the dermis of the papillæ, and branching off to the buds. Note also the layers of striated muscle and the glands of the tongue, comparing the general structure with that of the œsophagus (Lesson XVI. B.) and of the skin (Lesson XXIV. A.).
4. Tease out a small piece of a papilla foliata which has been placed in osmic acid .2 p.c. for one or two days, and observe the characters of the cells of the taste-buds, noting the branched central process of the rod-cells.

## B. SENSE OF TASTE AND SMELL.

1. Pinching the nose tightly, so as to suspend the sense of smell, attempt with the eyes shut to distinguish by taste between pieces of an apple, an onion, and a potato; they will taste alike. The pieces must not be rubbed against the mouth with the tongue, or they will be recognized by their different consistency.
2. Wipe the tongue quite dry, and place on the tip a crystal of sugar or on the back a crystal of sulphate of quinine; neither will be tasted until it is dissolved.
3. Apply with pointed, non-polarizable electrodes (cp. Appendix) a constant current to the tongue;

a distinct sensation of taste will be felt, of acidity at the positive pole (anode), of alkalinity at the negative pole (kathode).

Keeping the electrodes at the same distance, say two or three millimetres, determine the amount of taste-sensation in different parts of the mouth. It will be greatest at the tip and back (region of circumvallate papillæ) of the tongue, and edges of the tongue; least or absent in the anterior and middle surface, under surface of the tongue, and lips. The soft palate will be found to be highly sensitive, the hard palate little or not at all.

4. Take two small pieces of sugar of equal size, and place one on the tip, and the other on the back of the tongue; the sensation will be most acute at the tip.
5. Place a crystal of sulphate of quinine on the tip of the tongue; it will hardly be tasted. Place it on the back; it will be tasted at once.

## LESSON XXVI.

### THE EYE.

#### A. DISSECTION.

1. Take a fresh eye of an ox or sheep, and note
  - a. The transparent **cornea**.
  - b. Surrounding and continuous with this, the dirty-white **sclerotic** which forms the outer coat of the rest of the eye. The posterior two-thirds will probably be covered with fat.
  - c. The **conjunctiva**, a continuation of the mucous membrane of the eyelids. In taking the eye out of the orbit this membrane is cut through where it passes from the eyelids to the sclerotic. Dissect it forwards in any one place; it will be traceable to the junction of the sclerotic and the cornea. Its epithelium is continuous with that of the cornea (cp. B. 2).
2. Clear away the fat surrounding the four straight muscles, it will be seen that their tendons form a layer under the conjunctiva of the sclerotic.

3. Cut away the conjunctiva and muscles, and remove the fat around the **optic nerve**; this pierces the sclerotic on the nasal side, and not in the axis of the eye.
4. Cut through the cornea close to its junction with the sclerotic; the anterior chamber of the eye, containing clear, limpid **aqueous humour**, is thus laid bare. Observe the iris with its central aperture through which projects the anterior part of the lens.
5. At a little distance from the cornea, cut through the sclerotic, being careful not to cut too deeply; it will separate easily from the pigmented subjacent **choroid**, except at the junction of the sclerotic with the cornea, and at the entrance of the optic nerve. In other places there is only a loose connection, largely by means of blood-vessels. Remove a strip of the sclerotic a few mm. breadth stretching from the optic nerve to the cornea. Note its dark inner surface, or **lamina fusca**; note also in the front part of the choroid, close to the cornea, the pale fibres of the **ciliary muscle** spreading from the junction of the sclerotic and cornea, backwards over the choroid.
6. Carefully pinch up the choroid about half-way between the optic nerve and the cornea with a fine pair of forceps, and snip it through. Underneath it will be seen a thin membrane, the **retina**. The pigment layer of the retina will probably be torn away with the choroid.



7. Tear away a piece of the retina to expose the clear **vitreous humour** which occupies the posterior cavity of the eye.
8. Tilt the eye so that the cornea is underneath; through the vitreous humour can be seen the choroid coat becoming folded longitudinally as it approaches the lens, and so forming the **ciliary processes**.

The nervous elements of the retina cease at the level of the commencement of the ciliary process. Their termination is marked by an uneven line, the **ora serrata**.

9. Holding up the choroid and retina, cut them through as far forward as the ora serrata; it will be seen that the vitreous humour separates readily from the retina as far as that line, but in the region beyond its thin outer coat, the **hyaloid membrane**, becomes attached to the ciliary processes. If an attempt be made to separate them here with the handle of a scalpel, it will be found that the pars ciliaris retinæ (or the non-nervous continuation of the inner coat of the retina) together with some of the pigment layer of the retina (the outer coat) will come away with the vitreous humour.

At the ora serrata the hyaloid membrane becomes united to the membrana limitans interna of the retina.

10. Turn the eye with the cornea uppermost, and cut away the free edge of the iris; make two

incisions at right angles to one another on the surface of the lens, it will be seen that the lens is covered by a membrane; this is the anterior part of the **lens capsule**. Carefully remove the lens, and trace out the limits of the lens capsule, noting that it forms a complete investment for the lens.

11. Gently separate with the handle of a scalpel the lens capsule from the front part of the ciliary processes, and observe that a membrane, the **suspensory ligament** or **zone of Zinn**, passes from the edge of the capsule to the ciliary processes, of which it forms the innermost layer, dipping down into their depressions. Posteriorly it is continuous with the thin hyaloid membrane (cp. § 9).
12. Looking into the eye from the front, observe
  - a. The entrance of the optic nerve.
  - b. The blood-vessels running in the retina and radiating out from the entrance of the optic nerve.
  - c. The iridescence, mainly below the entrance of the optic nerve; it is caused by the irregular reflection of light from the wavy connective-tissue fibres of the choroid. In this region (the tapetum) the hexagonal cells of the retina have no pigment.
13. Separate the rest of the retina from the choroid, and observe that

- a. The pigment-layer generally adheres rather to the choroid than to the retina.
- b. Apart from the pigment-layer the retina appears like an expansion of the optic nerve.
- c. The retina is firmly attached to the choroid at the ora serrata.

## B. HISTOLOGY.

1. Take an eye which has been cut open and then hardened in potassium bicromate 1 p.c. It is best to take the eye of a large animal, e. g. of an ox. Cut out a piece containing the junction of the sclerotic, cornea and iris. Stain, imbed in spermaceti and castor oil (cp. Lesson xx. § 6), and cut sections extending from the outer to the inner surface. Observe
  - a. The irregular connective tissue of the sclerotic passing into the lamellæ of the cornea.
  - b. The membrane of Descemet (cp. § 2, c.) splitting up at the junction of the cornea and sclerotic into fine transparent bundles, some of which curve round towards the iris, the others spreading out fan-like a short distance into the ciliary process and sclerotic. These bundles of fibres form the **ligamentum pectinatum iridis**.
  - c. The **ciliary muscle**; consisting of bands of unstriated muscle, radiating from the angle of the iris and cornea. (In the eye of man

bundles of circular fibres, the circular muscle of Müller, inside the longitudinal fibres will be seen; in many lower mammals this part of the ciliary muscle is small or absent.)

- d.* The pigment-layer of the retina continuing forwards to form the uvea of the ciliary processes and of the iris. Inside this is a simple layer of columnar cells without pigment, this is a continuation of the inner coat of the retina.
  - e.* The canal of Schlemm at the junction of the cornea and sclerotic.
2. In sections of a **cornea** which has been hardened in mercuric chloride, and stained (cp. also p. 251), observe
- a.* The anterior epithelium. In this note
    - a.* The external flattened nucleated cells.
    - β.* The middle layers of roundish but irregular cells.
    - γ.* The internal single layer of columnar cells placed perpendicularly, cp. Lesson XXIV. *A.*
  - b.* The body of the cornea. Note
    - a.* The narrow transparent zone immediately beneath the epithelium, the anterior basement membrane of Bowman.
    - β.* The rows of connective-tissue corpuscles seen in profile, with numerous branches communicating not only with the cells

in the same row, but also with those below and above.

*γ.* The fibrous laminæ between which the cells are placed; here and there bundles running obliquely from one lamina to another may be seen.

*c.* The **membrane of Descemet** or posterior basement membrane: a thick hyaline membrane, with very sharp outlines.

*d.* The posterior epithelium, consisting of a single layer of large nucleated tessellated cells. In this section they are seen in profile, covering the membrane of Descemet.

### **Lens.**

3. Take an ox's or sheep's lens which has been in potassium bichromate '2 p.c. for a week; observe

*a.* The junctional lines of the lens fibres as a star.

*b.* The fibres readily peel off in laminæ.

4. Place the eye of a rabbit or cat, with the cornea and sclerotic cut through, in Müller's fluid for three weeks or longer; then cut out the lens with its capsule, and cut vertical sections through its centre and mount them in glycerine. The sections are best cut with a freezing microtome; neither the lens nor the sections of it should be touched with spirit. Observe

- a.* The hyaline capsule of the lens.
  - b.* The columnar epithelium of the anterior surface of the lens; at the sides these rapidly but gradually elongate into fibres.
  - c.* At the sides, the nuclei of the fibres forming an irregular band.
5. Take a lens as in § 4, and cut transverse sections through its centre. Observe the cross sections of the fibres, and their junctional lines.
6. Place the lens of a rabbit or rat in osmic acid .25 p.c. for about three hours; it will swell up somewhat, and the outer coat becomes jelly-like and easily torn; to obviate this, place it in gold chloride .25 p.c. for a minute or less; then tear off as long a strip as possible of the outer coat, and tease out in water. Observe the long band-like fibres with serrated edges usually adhering together in layers but in some cases isolated. In some of the fibres a nucleus will be seen; when the fibres form a layer, the nuclei appear as an irregular band running across it.

### **Iris.**

7. Cut out a piece of an iris from an eye which has been preserved in potassium bichromate, stain and cut radial vertical sections. Observe
  - a.* On the posterior surface, the **uvea** or thick layer of pigment epithelium-cells (cp. § 1, *d.*). The pigment will probably be too abundant to allow the outlines of the individual cells to be seen.

- b. The cross sections of the bundles of plain muscular fibres forming the **sphincter pupillæ** near the edge of the pupil, and lying just above the pigment-layer.
  - c. The body of the iris, consisting of blood-vessels united together by a loose connective tissue in which branched pigment-cells are conspicuous. Near the anterior surface is a denser layer, the so-called anterior limiting membrane. The radial muscular fibres (dilator) may (with difficulty) be seen near the posterior surface.
8. Take the iris from a white rat's or an albino rabbit's eye which has been preserved in Müller's fluid. Cut out a piece from the free edge to the attachment, stain with hæmatoxylin, clear, and mount in Canada balsam with the posterior surface uppermost. Observe the arrangement of the sphincter and dilator muscles.

### **Retina.**

9. Cut away the anterior half of the eye of a mammal immediately after death: avoid dragging the vitreous humour that the retina may not be displaced. Place the posterior half in potassium bichromate 2 p.c. or in Müller's fluid for a week, changing the fluid once or twice. After treatment with alcohol remove the retina carefully, carrying with it if possible the pigment-layer. Stain a small piece with hæmatoxylin, imbed it in spermaceti

and castor oil, clear the sections, and mount them in balsam.

10. Remove the retina from a fresh eye to osmic acid 1 p.c. After a few hours, treat with alcohol. Imbed and mount the sections in dilute glycerine. In all cases take a small piece for making sections. If long vertical sections are made they are very apt to turn over.

Examine the two preparations of § 9 and § 10, some points will be best seen in the one, some in the other. Observe the following structures from within (anterior surface) to without (posterior surface).

- a. The **inner limiting membrane**; from this the **fibres of Müller** are seen to start with a broad foot and to run vertically outwards, becoming thinner as they go; they may readily be traced as far as *f*, and may be followed to the outer limiting membrane (*h*), here and there anastomosing branches between the neighbouring fibres of Müller may be seen.
- b. The **layer of optic fibres**. The nerve-fibres here are without medullary sheaths, or rarely possess them.
- c. The **ganglionic layer**; this consists of a single layer of large nerve-cells with conspicuous nuclei. Externally a single process may be seen running into the optic fibre layer, internally several processes branching into



- d.* The **molecular layer**, consisting of a close network of fine fibrils; under a moderately high power it may appear simply granular.
  - e.* The **inner nuclear layer**, consisting of two to four rows of somewhat large, spherical or oval nuclei with nucleoli.
  - f.* The **outer molecular layer** or fenestrated membrane of the same appearance as *d.*
  - g.* The **outer nuclear layer**. In this the nuclei are spherical or oval, smaller but more numerous than in *c.*
  - h.* The **outer limiting membrane**, seen as a sharp well-defined line.
  - i.* The **layer of rods and cones**. Both limbs of the more numerous rods may be easily seen; the cones are shorter than the rods and are less obvious.
  - k.* The **pigment of the choroid** with the fine pencils of processes enveloping the outer limbs of the rods and cones.
11. Tear off a small piece of the retina from a sheep's eye preserved in Müller's fluid; probably the pigment-layer of the retina will be left adhering to the choroid. Take a small piece of this pigment-layer, and mount it in glycerine. Observe *en face* the single layer of hexagonal cells with large pigment-granules (cp. § 12, *b*).
12. Remove the retina of a frog immediately after death, and place it in osmic acid for 30 minutes

to 24 hours, as convenient; tease out in water in dilute glycerine. Observe the isolated fragments of the various layers, noting especially

- a. The large outer limbs of the rods, their striation and transverse lamination.
- b. The pigment-cells, each consisting of a colourless outer part, containing the nucleus, and a coarsely pigmented part, which splits up into a number of fibres, amongst which are imbedded the heads of the rods.

### DEMONSTRATION.

Effect on the iris of stimulating the sympathetic nerve.

Muscles of the eye dissected in the head of a sheep or dog.

## LESSON XXVII.

### VISION.

#### **Accommodation.**

1. Remove very carefully the sclerotic and choroid from a small portion of the posterior surface of the eye of an ox or a sheep. Place the eye in the end of a blackened tube just large enough to hold it, with the cornea outwards. On looking through the tube at any object, the inverted image will be seen shining through the retina.

Or,

The eye of any small animal, e.g. rat, may be used without any preparation, the sclerotic being sufficiently thin to be transparent. It will be found convenient to place the eye, with the cornea downwards, on the stage of a microscope, and to direct light through it by means of the mirror.

2. Standing some feet before a window, close one eye and hold up before the other, at a distance

of about six inches, a needle, so that it is at right angles to one of the horizontal bars of the window.

Look at the window-bar, the needle will appear dim and diffuse.

Look at the needle, the window-bar will appear dim and diffuse.

*The eye can accommodate itself for either the needle or the window-bar, but not for both at the same time.* The accommodation for the near object is accompanied by a distinct feeling of effort.

3. Facing a window, or a white surface, close one eye and hold a fine needle vertically before the other. At about six inches the needle will be seen distinctly. Bring it nearer the eye, the image will be dim and diffuse, and at the same time larger. The dimness and apparent increase of size are due to **diffusion**, resulting from imperfect accommodation.

Prick a small clean hole in a piece of card, hold it before the eye and again bring the needle close to the eye. It will be seen distinctly at a much smaller distance than before, and at the same time will appear magnified. It will be seen more distinctly because the diffusion circles are cut off. It will seem larger because, as it is nearer the eye, the rays which pass through the hole in the card are more divergent.

For a similar reason an object at a distance viewed through the same hole will appear

smaller when the eye is accommodated for a nearer object.

4. Prick in a card two small holes close together, so that both are within the diameter of the pupil. Holding the card before one eye (the other being closed) with the holes horizontal, hold a fine needle vertically at a distance of twelve inches. It will be seen distinctly as one when the eye is accommodated for it, but double when accommodation is made either for farther or nearer objects. Both the double images will be dimmer than the single one.

When a double image appears and

- a.* The eye is adjusted for far objects; stopping the right-hand hole will make the left-hand image disappear.
- b.* The eye is adjusted for near objects; stopping the right-hand hole will make the right-hand image disappear,

When the eye is exactly accommodated for the object, the rays passing through the two holes are united at the focus on the retina.

In *a*, the rays fall upon the retina before they are so united. Stopping the right-hand hole removes the image on the right-hand side of the retina. But images on the right-hand side of the retina are referred by us to objects on our left-hand side, hence it is the left-hand image which disappears.

In *b*, the rays are united, and cross at the

focus before they fall on the retina. Stopping the right-hand hole removes the image on the left-hand side of the retina; and the disappearance is referred to the right-hand side. Construct a figure to shew this.

When a single image is seen, stopping either hole merely makes the field of vision appear dim.

This is called **Scheiner's experiment.**

5. The image being one, bring the needle closer to the eye; at a certain distance it will become double; this marks the *near limit of accommodation*.

Fixing the needle on a sheet of paper, walk away while looking at it through the two holes; at a certain distance it will become double, this marks the *far limit of accommodation*. This experiment succeeds best with short-sighted people.

Compare the near and far limits of accommodation as fixed by looking at a vertical needle through horizontal holes with those fixed by looking at a horizontal needle through holes placed vertically. The results will differ according to the amount of astigmatism in the eye.

6. **Helmholtz's Phakoscope.** This should be used in a dark room. The observed looks with one eye through the hole opposite the needle. The observer looks through the hole at the side.

A lamp or candle is placed at some little distance from the prisms and shifted about until the observer sees on the eye of the observed, when the latter looks at a distant object, two small bright patches of light on the cornea, two larger but dimmer patches on the anterior surface of the lens, and two small and very dim (not readily seen) patches on the posterior surface of the lens.

Let the observed now accommodate for the needle in front of him, making every effort not to move the eyeball. The observer will see the two patches on the anterior surface of the lens approach each other, while the other two pair remain motionless, thus shewing that during accommodation for near objects the *anterior surface* of the lens becomes more convex.

Observe that in accommodating for near objects the pupil becomes smaller, and in accommodating for far objects the pupil becomes larger.

7. **Astigmatism.** Draw on a card a star composed say of eight lines passing through the centre, the angle between each two neighbouring lines being the same and the lines of equal tint and of equal thickness.

Place this at about the distance which has been determined (§ 5) as the far limit of accommodation (if this distance is more than eight or ten yards use convex spectacles).

Probably one or more of the lines will be seen much more distinctly and with less blurring than

the others. The direction of the line most distinctly seen represents the meridian of least convexity of the cornea. Approach gradually nearer the star and note whether the other lines become all visible at once or in succession.

Repeat this first with one and then with the other eye closed; the astigmatism may be different in the two eyes.

Then holding the star at a distance a little greater than the near limit of accommodation, fix the centre of the star with one eye, keeping the other closed, and bring the star gradually nearer; the lines will probably not all become dim at the same moment; the line which remains distinct longest will be the meridian of greatest curvature of the cornea; this is usually at right angles to that of least curvature, so that the line last seen with near accommodation will probably be at right angles to that first seen with far accommodation.

Instead of the star a number of parallel horizontal and parallel vertical lines may be drawn.

Or,

Fix a needle vertically on a board. Looking at the needle with one eye, accommodate the eye exactly for it. Then hold another needle horizontally before the first, and move it backwards and forwards until both needles are seen distinctly at the same time. This will be found to be the case when the needles are at some distance apart.



More exact results are however gained by Scheiner's method (§§ 4, 5).

8. **Irradiation.**

Cut out two patches of exactly the same size, of white and of black paper.

Place the white on a sheet of black and the black on a sheet of white paper.

Place them some distance off and adjust the eye so as to throw them a little out of the range of accommodation.

The white patch will appear larger than the black one.

9. **Blind Spot.**

Make a bold mark on a sheet of white paper, place the sheet on the table, and, closing the left eye, fix the axis of vision of the other, by steadfastly looking at the mark at a distance of about 10 inches. Dip a new quill-pen in black ink and place it close to the paper near the mark. Keeping the axis of vision fixed, and the head at the same distance from the table, move the pen outwards (towards the right) from the mark. At a certain distance it will become invisible; mark this spot on the paper. Carry the pen still farther outwards. It will again come visible; mark this spot also. The two spots will indicate the outer and inner limits of the blind spot. Similarly the upper and lower limits may be traced, and with a little practice an outline of the blind spot, shewing even the

commencement of the retinal blood-vessels as they emerge from the edge of the optic disc, may be constructed.

The size of the blind spot may be calculated from the formula  $\frac{f}{F} = \frac{d}{D}$ , where  $f$  is the distance of the eye from the paper,  $F$  the distance of the retina from the nodal point of the eye (average = 15 mm.),  $d$  the diameter of the outline on the paper, and  $D$  the outline of the blind spot.

#### 10. **Region of Distinct Vision.**

Fix the axis of vision by steadfastly looking at some mark. Make on a card two dots so close that they can just be seen as two when placed close to the mark. Keeping the axis fixed, move the card towards the periphery of the field of vision; the dots will soon appear as one.

Or,

Make two dots on a card 5 mm. from each other. Fix the axis of vision. Place the card outside the whole field of vision and gradually move it inwards towards the mark; the dots will first become visible as one, and only appear as two as they approach the centre of the field, and enter the region of distinct vision.

It will be found on examination that the outline of this region is not circular but very irregular.

#### 11. **Purkinje's Figures.**

Go into a dark room with a lighted candle:

looking steadfastly with one eye towards a wall<sup>1</sup>; hold the candle to the side of that eye so that while the eye is illuminated the image of the candle is not seen, and gently move the candle up and down. In a few seconds the subdued reddish glare caused by the candle-light will be marked by branching dark lines, which will be seen to form an exact image of the retinal vessels as seen with the ophthalmoscope. The dark lines are shadows of the blood-vessels; consequently the structures in which the physiological processes which give rise to the sensation of light begin must lie behind the retinal blood-vessels.

A cup-shaped space, in which the blood-vessels are absent, may with care be seen; this is the yellow spot.

Or,

Turn the eye inwards towards the nose so as to expose as much as possible of the thin sclerotic behind the cornea. Let an assistant with a lens concentrate the rays of a candle or lamp on the sclerotic as far behind the cornea as possible, so that the rays may pass directly through it towards the opposite side of the eye, and gently move the focus to and fro. The same image is still more distinctly seen. The smaller the focus on the sclerotic, the more distinct the image.

<sup>1</sup> A light-coloured wall or white blind is the best. A wall, the paper of which has any very marked pattern, should be avoided.

If the movement of the light is stopped, the image soon fades away.

In the first method the image moves in the same direction as the light when the light is moved from side to side, but in an opposite direction when moved up and down.

In the second method the movement of the image is in the same direction as that of the light, whether up and down or from side to side.

12. Look through a microscope with an empty field, illuminated, but not too brightly, by a white cloud, and gently move the head to and fro; an appearance of fine retinal capillaries will be seen as a dark meshwork on a finely punctated ground. In the centre may be seen a finely punctated spot devoid of capillaries. If the head be moved from side to side, a vertical meshwork will be seen; if up and down, a horizontal meshwork.

### 13. **The Yellow Spot. Maxwell's Method.**

Place a moderately strong, but perfectly transparent solution of chrome alum in a flat-sided glass vessel. Resting the eye for a minute or two, suddenly look through the vessel at a white cloud. A rosy spot or cloud will appear in the centre of vision and remain for some little time, but will gradually become less distinct.

The pigment of the yellow spot absorbs the blue-green rays between the lines *E* and *F* of the spectrum, these rays removed from those

passing through the chrome alum, viz. red and greenish blue, leave a rose colour.

**14. Region of normal colour-vision.**

Take small pieces of paper of various colours (about 10 mm. square). Fix the axis of vision, on a sheet of white paper, and place each of the coloured papers near the axis of vision, they will all be distinct.

Place a red piece near the axis, and then gradually move it towards the outside of the field of vision; it will first become yellow, then a dull white, and will finally disappear.

Repeat this with a green piece; similar changes are seen, but the yellow is darker.

Repeat this with violet, this becomes blue, then a dull white, and finally disappears.

**15. Positive After-Image.**

When waking in the morning, close and shade the eyes for a minute or two, then suddenly look at the bright window for a moment or two, and then close and shade the eyes again. The image of the window exactly corresponding to the natural one, i.e. with the sashes dark and the panes bright, &c., will last for some little time.

To succeed, the retina should be in rest beforehand, and the exposure to the stimulus momentary or nearly so.

Or, in the evening, having closed and shaded the eyes for some time, suddenly look at a lamp

and immediately close the eyes. A similar positive after-image will be seen.

This positive after-image must not be confounded with the negative after-image which comes later. It simply shews that the sensation is of longer duration than the application of the stimulus.

16. Look for an instant at a coloured light, and then look at a white or grey surface, a positive image *of the same colour* will for a brief period be visible.

### 17. **Negative After-Image.**

Look fixedly for about twenty seconds

- a. At a white patch (e.g. white wafer) on a black ground, and then look at a white surface (or preferably pass a white surface over the whole, keeping the visual axis fixed); there will be visible a corresponding dark patch on the white ground.
- b. At a black patch on a white ground, and turn to a grey surface; there will be visible a white patch on a grey ground.
- c. At a red patch on a black ground, and turn to a white surface; there will be visible a blue-green patch.  
And so with the other colours, the colour of the negative image will be complementary to that of the actual object.

- d. At a red patch on a black ground, and turn

to a yellow surface; there will be visible a green patch.

- e. Look fixedly at a brightly illuminated window and then close the eye. The *positive* after-image will probably not be seen; in its place there will come the *negative* after-image with the sashes as bright lines and the panes as dark spaces. This will in turn be succeeded by coloured images.

### 18. **Contrast.**

Place three candles in front of a white, otherwise un-illuminated surface; pass between them and the surface an opaque body with a sharp clean-cut edge, so that part of the surface is illuminated by the three candles, part by two, part by one and part un-illuminated; stand two or three yards back and look fixedly at the junction lines of the variously illuminated surfaces; it will be seen that each area is lighter close to a darker surface and darker close to a lighter one than it is elsewhere.

### 19. **Simultaneous Contrast.**

- a. Cut out a thin cross of grey paper, and place it in the middle of a sheet of bright green paper. Cover the whole with a sheet of thin tissue paper. The grey patch will appear pink. The exact tint of the patch will depend on the tint of the green, of which it will be the complementary colour.

Surround the grey cross with a broad dark black rim. The effect of contrast will be lost; the grey patch will appear grey.

On a red ground the grey cross will appear green, and with the other colours similar complementary effects will be produced; but the results are most striking in the case of red and green.

The effect is greatest when the patch is grey, not white, and is always heightened by covering with tissue paper.

- b. Cut a thin strip of grey paper and place it across the junction of a red with a green paper, and cover with tissue paper.

The grey will appear green on the red side and pink on the green side.

- c. Place a sheet of white paper on a table before a window illuminated by reflection from a white cloud, not with direct sunlight. On the side of the paper opposite the window place a lighted candle, and between it and the paper place a book edge-ways, or any object which will throw a shadow on the paper. Between the paper and the window place a similar object, throwing a like shadow. The distance of the candle should be such that the two shadows are of nearly equal intensity.

The shadow from the candle, though illuminated by the white sunlight, will appear blue, the complement of the reddish yellow colour



of the rest of the paper illuminated by the candle.

This effect of contrast is subjective, not objective. To shew this, blow out or place a screen before the candle so as to do away with the candle-light. The place formerly occupied by the shadow now appears white. Through a small black tube, e.g. a piece of black paper rolled up, with so small a bore that the whole field of view lies within the shadow, look at the centre of the area formerly occupied by the shadow. It still of course appears white. While looking, let some one light the candle, or remove the screen. No change will be visible to the observer looking through the tube.

If the tube however be directed partly on the area of the shadow, and partly outside, the blue tint of the shadow will, on the candle being lighted or the screen removed, become apparent as before.

The daylight-shadow heightens the effect on the candle shadow, but may be dispensed with.

In place of sunlight and candle, two coloured lights may be used.

In the above experiments (§§ *a*, *b*, *c*) avoid looking at the colours too fixedly and for too long a time. Otherwise the results will be modified by after-images,

20. **Visual Judgements.** Measure on a card two

equal squares ; without putting in the outline of the squares, fill in one with fine vertical lines one to two millimetres apart and the other with similar horizontal lines the same distance apart. Place them a short distance off, they will appear not square but oblong. The side at right angles to the direction of the lines looking longer than the side parallel to the direction of the lines.

### DEMONSTRATIONS.

1. Kühne's artificial eye.
2. Mixing of colour sensations with the colour top.
3. Method of testing colour blindness with skeins of coloured worsted.

## LESSON XXVIII.

### THE EAR.

#### A. SKATE.

1. Cut through with a strong sharp scalpel or with bone forceps the cartilaginous roof of the skull transversely between the eyes; remove the posterior part of the roof. Opposite the hinder part of the brain the cartilage will be seen to be much thicker than elsewhere; it contains the vestibule and semicircular canals: slice it away till one of the semicircular canals is reached; when this is done, trace it, removing the upper portion with a scalpel or a strong pair of scissors.  
Note

- a. The almost transparent **membranous canal** much smaller than the cartilaginous canal in which it lies.
- b. The **ampulla** or spindle-shaped dilatation of the membranous canal close to one end.
- c. The opening of the semicircular canal at either end into a large membranous bag, the **utricle**.

- d.* The **sacculus**, a membranous bag not so large as the utriculus and separated from it only by a shallow constriction.
  - e.* The rudiment of a cochlea appearing as a small projection from the anterior end of the sacculus.
2. Trace out the three 'semicircular' canals, the horizontal canal, the anterior and posterior vertical canals, the two latter uniting at their non-ampullary ends. Observe that the planes passing through these canals are at right angles to one another. A tube may be noticed running upwards from the utriculus, close to the point of entrance of the two vertical canals, to open on the surface of the body: the recessus vestibuli of mammals is homologous with this.
  3. Cut through a membranous semicircular canal and pull up with forceps the part connected with an ampulla; the canal separates from the cartilage readily, but the ampulla is more firmly attached at one spot, the **crista acustica**, where a branch of the auditory nerve enters; cut through the ampulla at either end, and with a sharp scalpel cut through the nerve close to the cartilage; cut open the ampulla on the side opposite the entrance of the nerve and note the ridge of the crista acustica running transversely a third to a half way across the tube, where the nerve enters it.

4. At the lower part of the utriculus and sacculus note the white calcareous paste, lift up the membranous bag and note that beneath the paste, nerve fibres enter through the cartilage. Remove the membranous vestibule and canals, sop up any fluid with a sponge and moisten the cartilaginous vestibule and canals with osmic acid; in a short time the nerve fibres entering through the cartilage become blackened and so very distinct.
5. Trace towards the brain, cutting through the cartilage, one of the nerve bundles, e.g. that entering the utriculus.
6. Lay bare the semicircular canals in a fresh skate and cut out an ampulla as in § 3; place it in picric acid or in chromic acid '2 p.c. for a week, treat with alcohol, stain with hæmatoxylin, and imbed, soaking previously a short time in the imbedding mixture, clear the sections on the slide and mount in Canada balsam.  
In sections through the crista acustica observe
  - a. The outer loose connective tissue, and
  - b. The thick connective tissue wall.
  - c. The numerous large nerve fibres running from the outside towards this; the fibres may be traced through the membrane becoming much smaller and some losing their medulla.

- d.* Two or more layers of **cells** with **large nuclei**; long processes may be seen to proceed upwards from some of these.
- e.* Superficial **columnar cells**.
- f.* Fine **fibres** projecting beyond the columnar cells; if care has not been taken these will have been broken off; in any case it will be difficult to make out whether the processes run between the cells or from their extremities. In sections through any other part of the ampulla observe,
- g.* The thinner connective tissue wall,
- h.* The single layer of short columnar or even flattened cells.
7. Place another ampulla in osmic acid 1 p.c. for half-an-hour or longer; tease out a piece of the crista acustica in water or in dilute glycerine and observe the nerve fibres with blackened medulla in the wall of the tube, and the isolated cells (§§ *b, c, d*).
8. Scrape off a little of the epithelium from the crista acustica of a fresh ampulla and tease out in a drop of endolymph to observe the characters of the fresh cells.

## B. MAMMAL.

1. Take the head of a cat<sup>1</sup>, and cut away all the soft tissues surrounding the tympanic bulla, having snipped off the external meatus as close to the skull as possible, look down and observe the **tympanic membrane**; it is placed obliquely to the canal and faces forwards, outwards, and downwards. The attached handle of the malleus may be seen shining through it.
2. Place the head with the lower jaw uppermost, and with a strong pair of forceps break away piecemeal the projecting part of the bulla. The cavity thus exposed has a floor<sup>2</sup> made irregular by projections. Note in the centre a projection of somewhat yellowish bone running in the long axis of the bulla; this is the **promontory** of the **cochlea**: at a lower level in the exterior and posterior part of it will be seen a round depression, the **foramen rotundum**.
3. In front and outside the cochlea is a projection of thin bone which prevents the membrana tympani from being seen; it divides the tympanic cavity into two parts communicating by

<sup>1</sup> The details of arrangement differ considerably in different animals: the following description applies to the cat, the more general features may however be made out in other mammals.

<sup>2</sup> It must be particularly noticed that the words floor, roof, exterior, posterior, etc. are here used with reference to the position of the head *during the dissection*; the position of the parts when the head is placed in the normal position should also be observed.

an aperture over the foramen rotundum; this arrangement is a characteristic of the Felidæ; break through the bone from above and very carefully remove it in pieces with forceps. The rest of the cavity of the tympanum is thus exposed.

Note the funnel shape of the membrana tympani; it has the handle of the malleus attached to it; this proceeds from the outside attachment of the membrane slightly upwards to a little past the middle point of the membrane (cp. foot-notes, p. 295).

4. Running out from a bony rim behind the membrana tympani in the outer part, will be seen a band of tissue stretching to the outer, anterior edge of the bony rim surrounding the foramen rotundum; from this a thin ligament proceeds at right angles to the former band to be inserted into the head of the malleus. This is the **posterior ligament** of the **malleus**.
  
5. On the opposite side of the head of the malleus and in the same straight line, note the **processus gracilis** running down to the lower edge of the membrana tympani; it is attached here to the bony wall by the **anterior ligament** of the **malleus**; do not attempt to trace the ligament till the malleus is removed later on. The tissues in the straight line thus followed down form the **axis band** of the malleus, i.e. the axis about which the ossicula auditûs turn.



6. Proceeding from the head of the malleus nearly at right angles to the axis band, inwards and downwards is a bony process to which is attached, by a very short tendon, the **tensor tympani muscle**. Press this towards its origin with a seeker and note that it tightens the membrane. Press lightly on the end of the handle of the malleus, it has but a small excursion.
  
7. With a fine pair of scissors cut through the attachment of the membrana tympani, except at the handle of the malleus, and with a small pair of bone forceps remove the upper part of the bony ring to which it was attached. The malleus will remain in position. The incus and stapes may be indistinctly seen deep down on the outer side.

In order to make out well the relation of these great care is required. Take a fine saw and proceeding from behind in a plane passing just outside the incus, saw away the external piece of bone.

Observe then

- a. The rather long slender neck, and knobbed head of the malleus.
  
- b. The **incus** with two processes, one passing almost horizontally backward and by a ligament attached to the bony tympanic wall, the other proceeding upwards, and attached to the head of the **stapes**. When the bones are removed later, the saddle-shaped surface

of articulation of the incus with the malleus should be observed.

- c. The **stapes**, much more transparent than the other bones; the base fits into an oval depression, the **fenestra ovalis**. Observe the **stapedius muscle** passing backwards from the head of the stapes to the aqueductus Fallopii at the lower, outer part of the cochlea.
8. Take out now the ossicula auditus, and observe further the shape of each.
9. To the inner side, rather in front of the attachment of the tensor tympani muscle, observe the opening of the **Eustachian tube**; pass a probe down it and note the pharyngeal opening.
10. With a small pair of bone forceps, break away the wall of the cochlea proceeding from the foramen rotundum towards the apex of the bony cone. Observe the coils of the cochlea with the central piece of bone or **modiolus** and the projecting **lamina spiralis**.
11. With a strong pair of forceps remove the petiotic bone from the skull and cut through the cochlea down the modiolus. Observe the nerves running up its centre.
12. Starting from the fenestra ovalis the vestibule may be exposed, the openings of the semicircular canals seen and traced out in the bone, but this

is not easy, and the arrangement differs but little from that in the skate.

13. Take the cochlea of a mammal, preferably of a guinea-pig, which has been treated with picric acid until the salts have been dissolved out, and subsequently with alcohol. Remove all the softened bone as close as possible to the cochlea. Slice away the apex of the cochlea, stain the remainder with hæmatoxylin and imbed in the manner given in Lesson xx. § 6. Cut sections through the axis of the cochlea, throw away the first two or three and the last two or three sections; clear the rest on a slide with creosote and turpentine, mount in Canada balsam.

Observe

- a. The division of each turn of the cochlea into three canals by the **basilar membrane** running across from the end of the lamina spiralis, and by the **membrane of Reissner** starting from the lamina farther back; the latter will very probably have been torn through.
- b. The following modifications of the epithelium cells of the scala media, starting from the inner side of the basilar membrane.
  - a. Cells passing from cubical to columnar.
  - β. The single **inner hair cell**, columnar with short rod-like processes, the so-called hairs, from its free surface, its deep pointed end is more or less hidden by small cells with large nuclei.

- γ. The **inner** and the **outer rod of Corti**.
- δ. The three or four **outer hair cells**, long irregular cells, not perpendicular to the membrane, but bending inwards, with short rod-like processes projecting from the surface, and deeply seated nucleus; occasionally two nuclei are seen in a cell.
- η. The rings of the reticular membrane surrounding the tops of the inner and outer hair cells.
- θ. Cells passing from columnar to cubical, inclining inwards, like the outer hair cells.
- c. The membrana tectoria proceeding from a projection of tissue on the lamina spiralis, thence enlarging and forming a more or less distinct pad above the organ of Corti; in the preparation it will probably be considerably shrunken.
- d. The nerves running along the lamina spiralis towards the basilar membrane.

## LESSON XXIX.

### SPINAL CORD.

1. MAKE transverse sections of the hardened spinal cord of a cat or dog through the region of the cervical enlargement (say at the origin of the 5th cervical nerve). Stain the sections with dilute carmine or picrocarmine for a day, clear and mount in Canada balsam.

The cord should have been placed in ammonium or potassium bichromate 2 p.c. for three or four weeks, then washed with water, placed in 30 p.c. alcohol for several days changing the fluid each day, then placed in 50 p.c. alcohol, which should be renewed until it no longer becomes coloured. The cord may be kept in 75 p.c. or in strong alcohol. It is best stained by placing the piece to be cut in strong Frey's carmine for several days, it may then be well washed with water, soaked in gum for a day, and cut with the freezing microtome.

Observe under a low power the following general features

- a. The **pia mater**, surrounding the cord; it consists of two coats (cp. § 3 a.); the inner

coat sends into the cord numerous septa. Note the blood-vessels running from the pia mater into the cord along the septa.

- b.* The **anterior** and **posterior fissures**; the pia mater dips down into the anterior fissure; the posterior fissure contains a prolongation of the inner coat only of the pia mater, the outer coat running over the fissure.
- c.* The entrance into the cord of the **anterior roots** of the spinal nerves in several small bundles.
- d.* The entrance into the cord of the **posterior roots** of the spinal nerves in a compact mass.
- e.* The **white substance** forming the outer part of the cord and divided on each side by the entrance of the nerve roots into **anterior, lateral** and **posterior columns**; since the fibres of the anterior root do not enter the cord in one bundle (cp. *c.*) there is no definite line of division between the anterior and lateral columns.
- f.* The **grey matter** projecting on each side into an **anterior** and a **posterior cornu**, but with no distinct separating line between them.
- g.* The **central canal**; it may be plugged up with epithelial cells;
- h.* A ring of deeply stained neuroglia around the central canal, and

- i. On either side of this, the anterior and posterior **grey commissures** of deeply stained substances in which crossing nerve fibres are seen.
  - k. The anterior **white commissure** consisting of fairly large decussating nerve fibres in front of the anterior grey commissure.
  - l. A round or oval deeply stained area, the **substantia gelatinosa**, forming the hinder part of the posterior cornu.
2. Examine the same section first under a low and then under a high power. Observe
- a. The large multipolar nerve cells of the anterior cornu placed chiefly in the anterior and lateral part of the cornu; they may be more or less distinctly arranged in two or in three groups.
  - b. The transverse fibres (longitudinal in the plane of the section) running from the posterior part of the anterior cornu into the lateral column.
  - c. The fibres of the posterior root running (a) transversely through the substantia gelatinosa, ( $\beta$ ) obliquely into the posterior column.
  - d. Transverse and oblique fibres running from the posterior column into the posterior cornu.

3. Under a high power repeat the observations of § F, Lesson x. and observe further
  - a. The outer coat of the pia mater consists chiefly of white fibrous tissue; the inner chiefly of fine elastic fibrils.
  - b. The central canal is lined with a layer of columnar epithelium cells.
  - c. In the grey substance, a fine small-meshed network of fibrils, lying in a punctated or granular-looking matrix.
  - d. The nerve fibres, many medullated, of all sizes, throughout the grey substance (in the ring around the central canal the nerve fibres are very few and small, in the substantia gelatinosa they are chiefly the fibres of the posterior roots). Note the fibres running across the anterior and posterior grey commissures and compare the anterior grey with the white commissure.
  
4. Prepare transverse sections of the spinal cord of a cat or dog taken through the dorsal and lumbar regions (say through origin of 9th dorsal and 4th lumbar nerves) and compare them with the section of the cervical region. Observe
  - a. The sections taken from the cervical and lumbar regions are larger than those taken from the dorsal region.
  - b. The enlargements in these regions are largely due to an increase in the quantity of grey



matter; note the relatively small number of nerve-cells in the anterior cornu of the dorsal region.

- c. The quantity of white substance. (number of nerve fibres) is greater in the dorsal than in the lumbar region, and greater in the cervical than in the dorsal, i.e. *the quantity of white substance in the cord increases from below upwards.*
- d. In the cervical region the posterior column is divided into two parts, a median part, the **fasciculus of Goll**, and a lateral part, the **fasciculus cuneatus**, by a septum of connective tissue (the fasciculus of Goll may be traced some distance down the dorsal region becoming smaller in its course).
- e. In the dorsal region there is a small lateral collection of nerve cells in the grey substance behind and laterally of the central canal; this is **Clarke's column**, or the posterior vesicular column. It becomes indistinct in the upper dorsal and lower lumbar regions.
- f. In the dorsal region there is a lateral projection of the grey substance about mid-way between the anterior and the posterior cornu, this is the *tractus intermedio-lateralis*; in it is a group of nerve cells; in the cervical and lumbar regions this group of cells blends into that of the anterior cornu.

- g.* In the lumbar region, the nerve fibres of the anterior root spreading out in the grey substance, some may be seen running across to the other side of the cord and forming part of the anterior white commissure (the course of the fibres of the anterior root is the same in the other regions of the cord but usually less distinct).

The Student should be able to recognize a section of the spinal cord as belonging to the cervical, the dorsal or lumbar region; in doing this, the chief points to be noticed are:—the presence or absence of Goll's column, of the tractus intermedio-lateralis (lateral cornu), and of the collection of cells forming Clarke's column; the relative amount of white and of grey substance; the shape of the anterior and of the posterior cornu; and the position of the central canal.

5. Place a short piece of the spinal cord of an ox in potassium bichromate .2 p.c. for a few days, and after the chromium salt has been removed by 30 p.c. alcohol, place the piece in strong Frey's carmine for a week or longer. With free hand cut a thick section from the anterior cornu and the neighbouring part of the anterior column and tease it out in a small quantity of glycerine under a dissecting microscope, trying to isolate one or more of the large nerve-cells seen and throwing away the rest of the tissue. In the more or less isolated cells observe

- a.* The single unbranched axis-cylinder process.
  - b.* The numerous remaining processes (protoplasmic processes) frequently branching, some may be seen to divide into very fine fibrils.
6. Cut an antero-posterior longitudinal section passing through both the anterior and the posterior nerve-roots. Note
  - a.* The longitudinal medullated fibres of the anterior column.
  - b.* The anterior nerve-roots entering obliquely.
  - c.* The nerve-cells and fibres of the anterior cornu.
  - d.* The substantia gelatinosa of the posterior cornu, with vertical fibres on either side and curved fibres running through it.
  - e.* The longitudinal medullated fibres of the posterior columns, in which can be seen
  - f.* The cut ends of the posterior nerve-roots.

### DEMONSTRATION.

Section of spinal cord prepared by Weigert's method to show medullated fibres in the grey substance. (Cf. p. 396).

## LESSON XXX.

### THE BRAIN.

#### A. DISSECTION OF THE BRAIN<sup>1</sup> OF A DOG OR OF A SHEEP.

1. Note the dura mater and pia mater (cp. Lesson I. B § 3, 5, c).
2. Cutting away the dura mater and carefully handling the brain to avoid tearing the nerve-roots, observe
  - a. The **cerebrum** overlaps the anterior part of the **cerebellum** (the overlapping is less in the sheep than in the dog).

<sup>1</sup> The brain should be removed from the skull as carefully as possible, especial pains being taken to cut the internal carotid arteries and the cranial nerves close to the skull. When the brain is removed it is best to tie the internal carotid arteries, and inject into the basilar artery first salt solution to wash out the blood as much as possible, then dilute and finally strong spirit; it is then placed in strong spirit; it may be dissected in a few days, but it is better to leave it in the spirit for three or four weeks. If the brain be not injected, it should be placed for two or three days in *weak* spirit of about 50 p.c., and then transferred to 90 p.c. spirit; in this it should be left for a month or more to harden it thoroughly.

- b.* The cerebellum covers the dorsal part of the **medulla oblongata**.
3. Tearing away as much of the pia mater as may be necessary, turn forward the cerebellum; the posterior dorsal surface of the medulla oblongata will be seen. Note
- a.* The **choroid plexuses** of the fourth ventricle, appearing on either side as a very vascular projection of the pia mater; they lie immediately above the thin epithelial roof of the ventricle; tear them away to expose the posterior half of the **fourth ventricle**.
- b.* The diverging posterior columns of the spinal cord; the fasciculus of Goll (cp. Lesson XXIX. § 4, d.) is continued on as the **fasciculus gracilis** which forms the lateral wall of the posterior part of the fourth ventricle; laterally of this is seen the **fasciculus cuneatus** continuous with the fasciculus cuneatus of the cord (cp. Lesson XXIX. § 4, d.).
- c.* The oblique fibres running from the lateral and anterior columns over the fasciculus cuneatus and apparently blending with it; the depression between the fasciculus gracilis and the fasciculus cuneatus at the same time disappearing, so that soon after the posterior columns have diverged, a single rounded eminence, the **restiform body**, is seen.
- d.* Anteriorly the restiform bodies run into the

cerebellum, constituting the **inferior peduncles** of the **cerebellum**.

4. Turn back the cerebellum, tearing away the pia mater which dips down in front of it. Observe
  - a. The **corpora quadrigemina**, consisting of two round and rather large anterior bodies, and two smaller posterior bodies. The anterior corpora quadrigemina are partially covered by the cortex of the cerebrum.
  - b. The **superior peduncles** of the **cerebellum**, one on each side, proceeding from the cerebellum as a roundish cord and disappearing underneath the posterior corpus quadrigeminum of the same side.
  - c. The **valve of Vieussens**, a thin layer of nervous substance stretching between the superior peduncles, and covering in the anterior part of the fourth ventricle. In the anterior part of the valve the roots of the fourth nerve may be seen rising from the middle line, and curving round to reach the base of the brain.
  - d. Tear away the valve of Vieussens and observe the anterior triangular part of the **fourth ventricle**, its lateral boundaries are the superior peduncles of the cerebellum.
5. Note on the under (ventral) surface of the medulla oblongata, without tearing away the pia mater,

- a. The **anterior pyramids**, two rounded cords one on either side of the median line.
- b. The **pons Varolii**. At its lower edge are transverse fibres forming a narrow band, the trapezium, which dips down underneath (dorsally of) the anterior pyramids; anteriorly to this are transverse fibres forming a broad band which runs over (ventrally of) the anterior pyramids; the band has a median shallow depression. In man the fibres of the trapezium are not seen on the surface of the pons. Note on each side the continuation of the transverse fibres of the pons into the **middle peduncle** of the **cerebellum**.
- c. The **inferior olivary bodies**, two slight oval elevations one on each side, laterally of the anterior pyramid and just below the trapezium. These will be seen more distinctly when the pia mater has been torn away (cp. § 10).
- d. The **crura cerebri** or peduncles of the cerebrum, two broad roundish bands which appear at the anterior edge of the pons, and run forwards diverging from one another.
- e. The **posterior perforated space** between the diverging fibres of the crura cerebri.
- f. The round projecting **corpus albicans** or **mammillare** in front of the posterior perforated space. In the dog there is a shallow median groove dividing it in two.

- g.* Immediately anterior to this a small area the **tuber cinereum**, from this springs the funnel-shaped **infundibulum** leading to the round **pituitary body**; cut across the infundibulum and observe the central space, which leads into the third ventricle. (The pituitary body may have been torn away in removing the brain from the skull.)
- h.* The **optic tracts**, two flat bundles of fibres coming obliquely forward over the front part of the crura cerebri, and meeting in the middle line to form the **optic chiasma**: from this a small piece of the optic nerve will be seen coming off on each side.
6. Observe the division of the cerebellum into a median and two lateral lobes, cut through the middle peduncle (§ 5, *b*) on each side where it passes from the cerebellum, and remove the cerebellum; divide it into four pieces two by a longitudinal and a transverse cut and note, the depth of its fissures, the white substance radiating outwards in the laminæ, and covered by a thin layer of grey substance, the whole having a distinctly arborescent appearance. In the midst of the central mass of white substance in the lateral lobes may be seen a greyer area representing the corpus dentatum of man; it is more distinct in a brain preserved in ammonium bichromate.
7. Observe now more closely the exposed fourth ventricle. It has a roughly rhomboidal shape;



its posterior triangular portion is the **calamus scriptorius**; note the opening of the central canal of the spinal cord into this; note also at the anterior end of the fourth ventricle the **aqueduct of Sylvius** or **iter** underneath the corpora quadrigemina; it runs from the fourth to the third ventricle (cp. § 19).

8. Trace the chief blood-vessels running in the pia mater of the under surface of the brain, tearing away the pia mater where necessary but being careful not to tear away at the same time the nerve-roots. At the upper part of the medulla will be seen two arteries. These are the **vertebral arteries**, which having given off recurrent branches along the anterior fissure of the medulla, curve round to unite in the median line; the vessel formed by their union is called the **basilar artery**, and runs forwards in the median line of the pons Varolii. At the front edge of this it divides into the two **posterior cerebral arteries**, each of which running obliquely forward passes to the median side of the third nerve as it springs from the crus cerebri.

Just beyond this each posterior cerebral divides into two branches. One of these runs backward; the other proceeding forwards, is, a little behind the optic commissure, joined by the **internal carotid artery**. Each arterial trunk so formed passes round the optic commissure, and divides into the **middle cerebral artery**

which crosses the olfactory lobe, its main branch running in the fissure of Sylvius, cp. C, § 6, giving off numerous branches, and the **anterior cerebral artery** which passes forwards between the front lobes of the cerebrum, having a transverse communicating branch with its fellow of the opposite side. The anastomoses between the branches of the posterior cerebral and the internal carotid arteries and those between the two anterior cerebral arteries complete the **circle of Willis**.

9. Now carefully tear away the pia mater and observe the points of exit of the following nerve-roots (cp. Lesson I. p. 12).
- a. The third pair of nerves, arising from the inner surfaces of the crura cerebri in front of the pons Varolii (cp. § 8).
  - b. The fourth pair of nerves, which will be seen curving round the front edge of the pons; they originate a little behind the corpora quadrigemina (cp. § 4, c).
  - c. The fifth pair of nerves, large and conspicuous, arising from the sides of the pons.
  - d. The sixth pair of nerves, arising in front of the olivary bodies and anterior pyramids close behind the pons.
  - e. The seventh pair of nerves seen at the lower edge of the pons nearly in a line with the fifth pair, they arise from the trapezium in a line with the outer border of the inferior

olivary body. (Their superficial origin is different in man.)

- f.* The eighth pair of nerves just outside the seventh; they cling to the lateral surface of the medulla, they will be seen on the dorsal surface passing over the restiform bodies. Note the small bundles of fibres (*striæ acusticæ*) passing over the restiform bodies into the fourth ventricle.
  - g.* The ninth, tenth and eleventh pairs of nerves each arising by several roots which form a line on the lateral part of the medulla; this line in its lower portion is continuous with the line of the posterior roots of the cervical nerves; the eleventh pair has origin also from the spinal cord, it may be traced downwards on the surface of the cord to about the sixth cervical nerve.
  - h.* The twelfth pair of nerves arising by several roots between the anterior pyramids and olivary bodies.
10. Observe again the ventral surface of the brain (§ 5), removing the pia mater.
  11. Separate the hemispheres and observe the **corpus callosum**, noting its curve in front (*genu*) and its curve behind (*splenium*).
  12. Cut away in thin slices the dorsal surface of the hemispheres, nearly down to the level of the corpus callosum, noting the outer grey substance and the inner white substance;

Make a shallow cut along each side of the corpus callosum and pull up the cortex on the outside of the cut; a space, the body of the **lateral ventricle**, will be seen; carefully cut away the roof of this space, which will then be seen to run forwards as the anterior cornu and backwards and downwards as the descending cornu of the lateral ventricle; on one side completely remove the cortex above the cornua. Observe

- a.* The **nucleus caudatus** of the corpus striatum, seen as a large rounded projection into the anterior cornu and continued backwards as a tapering mass (tail of the nucleus) on the outer side of the body of the ventricle.
- b.* The **hippocampus major**, a rounded projection of the floor and medial wall of the descending cornu.
- c.* The floor of the body of the lateral ventricle consisting of a thin lamina (cp. § 15), the **fornix**; continuous posteriorly with the hippocampus.
- d.* The **choroid plexus** of the lateral ventricle covering the lateral edge of the fornix and of the hippocampus. At the junction of the body of the ventricle with the anterior cornu the choroid plexus dips down underneath the fornix.
- e.* Turn laterally the choroid plexus and observe the band of white substance running from the fornix along the edge of the hippocampus forming the **fimbria** of the hippocampus.

*f.* Carefully pass a seeker underneath the edge of the fornix and of the fimbria; note that they can be raised from the subjacent parts and that the choroid plexus dips underneath them.

13. Gently raise the corpus callosum, a thin membrane the **septum lucidum** will be seen stretching from its under surface to the fornix and separating the lateral ventricles of the two sides.

14. Cut through the corpus callosum near its posterior end and turn it forwards, cutting through the septum lucidum; indications of the formation of the septum from two membranes will be seen, in its anterior portion a narrow space the **fifth ventricle** may be seen. Cut through the corpus callosum anteriorly and remove it.

The parts of the fornix previously noticed in each lateral ventricle are now seen to be joined in the median line forming a triangular lamina. Anteriorly this dips down some little distance behind the genu of the corpus callosum; as it dips down it divides into two round cords, the **anterior pillars** of the **fornix** (these will be better seen when the fornix is cut through (§ 15)); the part of the fornix where these pillars are joined is called the **body**, this is small in lower mammals since the pillars soon diverge posteriorly; where they diverge they are called the **posterior pillars** of the fornix, these run on to form the fimbriæ of the hippocampus (cp. § 12, *e*) and also send fibres which run over the inner surface of the hippocampus.

15. Carefully cut through the anterior portion of the fornix and turn it back, being careful not to drag with it the choroid plexus; the choroid plexus of each side will be seen to curve back slightly and join with the other in the median line; the space left on either side between the choroid plexus and the anterior pillars of the fornix is part of the **foramen of Monro**. The remaining part of the foramen of Monro is the space in the median line between the anterior portions of the choroid plexuses where they join; this leads into the third ventricle (cp. § 19); the foramen of Monro is thus roughly a Y-shaped space, one limb communicating with the third ventricle and each of the other two with a lateral ventricle at the junction of the body with the anterior cornu.
  
16. The vascular membrane underneath the fornix is the **velum interpositum**, this is seen to be continuous anteriorly with the recurved ends of the choroid plexuses about the foramen of Monro and laterally with the whole length of the choroid plexus of the lateral ventricles, in fact the choroid plexuses are only the free borders of the velum interpositum curving over the edge of the fornix and over its posterior pillars. (It is to be remembered that since there is an epithelial membrane running from the fornix over the choroid plexuses to the edge of the nucleus caudatus, the lateral ventricle has no opening except at the foramen of Monro.)

The space between the cortex and the mid-brain in which lies the velum interpositum is the so-called transverse fissure.

17. In the median line cut through the fornix, with the posterior part of the corpus callosum which remains attached to it;  
Note that the cortex curls a short way underneath the corpus callosum.
18. On one side pull the fornix and hippocampus backwards; note on the outer (lower) surface of the cortex, the **dentate** or **hippocampal** fissure; it is shallow and is situated a short distance from the edge of the fimbria, nearly opposite the middle of the hippocampus; it runs from the cortex underneath the corpus callosum (cp. § 17) to the extremity of the cortex of the descending cornu of the lateral ventricle; the projection of the hippocampus seen in the descending cornu is caused by the folding of the cortex round this fissure; note the lower surface of the posterior pillars of the fornix.
19. Turn back the velum interpositum; in separating the velum posteriorly note two projections downwards into the median space, these are the **choroid plexuses** of the **third ventricle**.  
The **optic thalamus** will now be seen on each side, a depression runs round its lateral boundary; between the optic thalami is a narrow space, the **third ventricle**. Note the tail of the nucleus caudatus stretching backwards for some distance laterally of the optic thalamus.

Note at the posterior part of the optic thalami in the median line the round **pineal gland**, and running from this near the middle line two thin white bands, the **peduncles** of the **pineal gland**, one over the optic thalamus of each side. Between the optic thalami, and running across the third ventricle, is seen the large **middle cerebral commissure**, of grey substance and hence very readily torn through.

20. Cut away on one side the cortex so as to completely expose the optic thalami and optic tract, and trace the course of the optic tract, carefully tearing away the pia mater. The optic tract will be seen to curve dorsally and form an eminence, the **external corpus geniculatum**, at the posterior lateral part of the optic thalamus; over this may be seen fibres running to the optic thalamus, and a rather large band of fibres curling back and running into the anterior corpus quadrigeminum (the so-called brachium of the ant. corp. quad.).
21. Below and behind the external corpus geniculatum a small eminence, the **internal corpus geniculatum**.

Both geniculate bodies are more marked in the dog than in the sheep; the position of these bodies is different in man; in man the backward projection of the optic thalamus or pulvinar has the position here occupied by the external geniculate body,

Disappearing underneath the posterior edge of the internal corpus geniculatum will be seen a



band of white fibres, the brachium of the posterior quadrigeminum.

22. Note the **anterior cerebral commissure**, a small compact bundle of fibres running transversely in front of the anterior pillars of the fornix.

Cut through the anterior pillars of the fornix to expose the commissure.

23. The **posterior cerebral commissure** underneath the pineal gland.

24. Cut through the anterior and middle commissures and trace the cavity of the third ventricle into the infundibulum; cut through the posterior commissure and the corpora quadrigemina and trace out the aqueduct of Sylvius.

## B. PARTS OF THE BRAIN SEEN IN SECTIONS.

1. Divide a brain in half by a longitudinal section carried carefully through the median line. Observe the relative positions of the structures visible on the cut surface, noting  
The obliquely cut fibres in the decussation of the pyramids; the transversely cut fibres of the ventral part of the pons; the valve of Vieussens; the corpora quadrigemina; the aqueduct of Sylvius; the posterior commissure, this will be continuous with transversely cut fibres forming a layer in the anterior corpus quadrigeminum; the pineal gland, a small piece of its peduncle running from it will be seen; the large middle commissure occupying a considerable portion of the third

ventricle; the corpus callosum; the septum lucidum, deep anteriorly, between the corpus callosum and the fornix; the pia mater entering the transverse fissure, forming there the velum interpositum which lies underneath the fornix and over the optic thalami; the anterior pillar of the fornix curving downwards in the direction of the corpus albicans; the anterior commissure a little in front of the apparent termination of the anterior pillar of the fornix; the posterior perforated space behind the corpus albicans; the optic chiasma.

2. Cut a transverse section of the mid-brain<sup>1</sup> passing a little in front of the pons and through the anterior corpora quadrigemina. Observe
  - a. Ventrally, and a little removed from the median line on each side, the **crusta** of the cerebral peduncle, it forms a slight projecting oval mass of transversely cut fibres.
  - b. A thin grey layer, the **substantia nigra** above the crusta.
  - c. The **central grey substance** around the aqueduct of Sylvius.
  - d. The **tegmentum**, between the substantia nigra and the central grey substance, elsewhere it does not show distinct boundaries.
3. Cut a brain through transversely carrying the cut a little in front of the corpus albicans and

<sup>1</sup> The parts described in this and in the succeeding section are much better seen in a brain which has been hardened in ammonium bichromate than in one hardened in alcohol.

across the Sylvian fissure (cp. C. § 6). Note on surface exposed

- a.* The band of white substance, the **inner capsule**, laterally of the optic thalamus.
- b.* The bands of white substance, **corona radiata**, continuous with the inner capsule and spreading out into the convolutions of the cortex.
- c.* The corpus callosum stretching between the coronæ radiatæ of the two sides.
- d.* The **nucleus caudatus** of the corpus striatum, a roundish grey mass, dorsal and lateral to the optic thalamus, and partially surrounded by the deep white band of the corona radiata; it may be very small in this section.
- e.* The **nucleus lenticularis** of the corpus striatum; this occupies a small triangular space just outside the inner capsule, and has a number of fibres running transversely through it from the inner capsule; on its lateral margin is a thin white band, the outer capsule.
- f.* The anterior pillar of the fornix will also be seen cut across, near the ventral surface of the grey substance close to the third ventricle; note also the position of the fornix.

### C. CONVOLUTIONS AND FISSURES OF THE DOG'S BRAIN.

1. Observe on the ventral, anterior surface of the brain the **olfactory bulb** (this may have

- been cut off) continuous posteriorly with the **olfactory tract**; pull this a little outwards, it is unconnected with the brain except posteriorly where it runs into the **olfactory lobe**.
2. Behind the olfactory lobe is a somewhat pear-shaped bulging, the lateral part of the **uncinate lobe**.
  3. Cut the brain in half through the median longitudinal fissure, press down the cerebellum and follow the course of the uncinata lobe in the posterior part of the cortex; it curves round as a rather narrow band and then runs upwards to the end of the corpus callosum, it runs also a little forwards underneath the corpus callosum (cp. A. § 17).
  4. At the end of the corpus callosum it joins the **supra-callosal convolution** which runs forwards above the corpus callosum.
  5. It will be seen that the above convolutions form a nearly complete ring round the cortex, they are all parts of the **internal convolution** or **limbic lobe**.
  6. Turning back now to the side of the brain, note the deep **Sylvian fissure** running upwards and backwards from about the apex of the part of the uncinata lobe here seen (cp. § 2); around this curves the **first** or **Sylvian convolution**.
  7. Curving dorsally around this is the **second** or **inferior convolution**.

8. Dorsally again of this is the **third** or **median convolution** having a longitudinal fissure in its posterior part.
9. Between the third convolution and the median longitudinal fissure is the **fourth** or **superior convolution**.
10. Looking at the median surface of the brain exposed by the cut made previously (§ 3), observe that the superior convolution stretches down to the supra-callosal convolution (cp. § 4).
11. In the anterior part of the dorsal surface of the superior convolution, note the deep **crucial fissure** running transversely and a little forwards, follow it on the median surface of the brain; it is seen to run into the fissure that lies above the supra-callosal convolution.
12. The bend of the fourth convolution around the crucial fissure is the **sigmoid gyrus**, the part in front of it being the anterior limb, the part behind being the posterior limb.
13. Anteriorly and posteriorly the four external convolutions join.

The above general plan of the convolutions is in special cases modified to some extent by secondary fissures, and by fissures being absent in part of their normal course (thus the fissure between the 1st and 2nd convolution is not infrequently incomplete) so that the typical arrangement given above may not be obvious at first.

14. In front of the anterior joined ends of the external convolutions is a deep fissure (the supra-orbital); the part of the brain in front of this is called the **sub-orbital lobe**.
15. Cut away the first convolution and note the surface of the cortex, **island of Reil**, lying at the bottom of Sylvian fissure.

#### D. HISTOLOGY.

1. Cut transverse sections of the spinal cord just above the origin of the 1st cervical nerve, at the beginning of the decussation of the pyramids. Note
  - a. The anterior and posterior cornua of the grey substance are partially separated from one another by bundles of medullated fibres springing from the lateral columns and extending some little distance in the grey substance towards the median line.
  - b. Some oblique bundles of fibres will be seen running through the grey matter on either side and crossing in front (ventrally) of the grey commissure, forming part of the decussation of the pyramids.
  - c. Medially of the anterior column will be seen a thin band of transversely cut small fibres; these are the fibres which have already crossed, the beginnings of the anterior pyramid.

d. The grey substance extending into Goll's fasciculus of the posterior column, and into the fasciculus cuneatus.

The appearances vary considerably in sections taken at different parts of the decussation.

2. Take a brain of a rabbit<sup>1</sup> hardened in ammonium bichromate and subsequently treated with alcohol. Cut out a piece from the middle of the dorsal portion of one hemisphere, extending from the surface to the lateral ventricle, and prepare vertical sections (preferably with a freezing microtome). Stain then with dilute carmine or picrocarmine, clear and mount in Canada balsam. Observe

a. The inner layer of horizontal nerve fibres (medullated) forming the white substance;

<sup>1</sup> The fresh brain should be placed in ammonium or potassium bichromate 2 p.c., the fluid changed on the following day (when the brain may be cut transversely in four or five pieces) and again in a week, then left about three weeks. It should then be cut up and the pieces washed with water for a day and with dilute spirit (first 30 p.c. then 50 p.c.) until all the excess of the chromium salt is taken out. The pieces may be stained with strong Frey's carmine during a week or more, washed well with water, soaked in gum and cut with a freezing microtome.

Instead of a rabbit's brain the brain of a cat or dog may be taken; a solution of the chromium salt may advantageously be injected into the basilar artery, but even then it is not easy to preserve the natural form of the cells of the 3rd and 4th layers of the cortex; the structure of the cortex in the cat and dog differs also at different points more than in the rabbit, the chief points of difference being the occurrence of very large cells in groups or singly in the lower part of the third layer, and the variation in number and extent of the angular cells, which may spread into the third layer or may be inconspicuous.

(between the fibres a considerable number of leucocytes will be seen); from this bundles of fibres at fairly regular intervals run out into the grey substance, usually ceasing to be distinct in the third layer (cp. *d*).

- b.* At the outer limit of this a layer of fusiform nerve cells lying amongst nerve fibres and forming the 5th layer of the grey substance of the cortex.
- c.* Outside this, a layer of small cells of various shapes, cells with three or more obvious though small processes predominating (angular cells); these form the 4th layer of the cortex.
- d.* Outside (*c*) are large pyramidal cells, the process from the apex of the cell tapering off from it and often being traceable upwards for a considerable distance; from the base three, four or more processes may be seen to proceed. The district of the large pyramidal cells forms the 3rd layer of the cortex; it will be seen that it is much thicker than any of the rest, and that generally speaking its cells diminish in size from within outwards. Small angular cells may be seen in its deepest part.
- e.* Outside the preceding layer is a thin layer with numerous small pyramidal cells, the peripheral process being usually distinct; this is the 2nd layer.



- f.* The 1st layer of the cortex, consisting of a fine network of fibrils showing a few very small cells.
  - g.* Blood vessels may be made out in all portions of the cortex, they are usually most conspicuous in the outer layers of the cortex running into it from the pia mater.
3. Prepare sections of a lobule of cerebellum extending from the surface to the inner white substance and at right angles to the direction of the folds. The hardening, staining, etc., are the same as for the cerebral cortex. Observe
- a.* The inner strand of medullated nerve fibres spreading into
  - b.* The nuclear layer, formed mainly of small cells closely packed together; these cells have a very small amount of cell substance, so that probably their deeply stained nuclei only will be seen.
  - c.* A single layer of large somewhat globular cells (Purkinje's cells); each has a large peripheral process which will be seen to branch, and the branches to branch again and so on, eventually extending as fine branching fibrils nearly to the surface of the cortex; close to the surface the fibrils become lost to view. Since the branches, especially the larger ones, run to some extent laterally, the processes from neighbouring cells will be

seen to cross one another. In a good specimen a small process may be seen to run from the deep portion of the cells towards the nuclear layer.

- d.* The outer layer of the cortex contains, besides the fibres from the cells of Purkinje, some scattered small angular cells with relatively large nuclei; from these cells one or more small branching processes may be seen to proceed, the fibres and cells being imbedded in a close fibrillar network; in this layer numerous capillaries will be seen.

## LESSON XXXI.

### DISSECTION OF THE LARYNX.

1. IT is preferable to obtain a fresh larynx of a sheep or an ox from the butcher's; but the spirit-preserved larynx of the dog (Lesson I.) will serve. The larynx will probably be obtained with the upper part of the œsophagus attached, and surrounded by a mass of muscle and connective tissue.

Having slit up the œsophagus lengthways, turn back or cut away the sides and observe the opening into the larynx bounded in front by the epiglottis, at the sides by folds of the mucous membrane, and behind by the large converging yellow crests of the arytenoid cartilages. On looking down into the larynx the opening between the vocal cords, or **rima glottidis**, may be seen at some depth below. Observe that the mucous membrane of the œsophagus is continuous with that of the larynx. Bend down the epiglottis projecting from the front, upper, edge of the larynx, and note that the passage to the larynx is then quite closed.

2. From the posterior surface carefully remove the œsophagus with the pharyngeal muscles. From the sides dissect away the sterno-thyroid muscle (Lesson I. p. 22), taking care not to injure the muscle lying underneath it (§ 3), and clear away the whole of the thyro-hyoid muscle which covers the side of the thyroid. The hyoid bone and thyro-hyoidean membrane may be left. The outlines of the thyroid will now come into view, clear away the connective tissue until they are quite distinct. Note that  
The **thyroid cartilage** consists of two lateral laminae, which meet in front and diverge behind, and have their upper and lower posterior angles prolonged, forming the upper and lower cornua. Observe in front the rounded projection or Adam's apple.
3. Observe the **crico-thyroid muscle** spoken of above (§ 2); dissect it away, noting its attachments. The **cricoid cartilage** will come into view, and it will be seen that the muscle in question passes from the posterior cornu and posterior portion of the lower margin of the thyroid, to the front part of the cricoid. Observe that below this muscle there is stretching between the two cartilages a membrane which limits the movements of the thyroid.
4. Observe the articulations of the posterior cornua of the thyroid to the cricoid. Disarticulate one cornu, cut through the crico-thyroid membrane,

and remove one half of the thyroid, taking care not to injure any of the muscles. Trace out with the finger the outlines of the cricoid cartilage. Note that

It forms a complete ring, which in front is narrow, and is covered by the edge of the thyroid, but behind is deep and enclosed on either side by the thyroid.

5. On the posterior surface of the cricoid note on each side of a central ridge two laminae of muscles, the **posterior crico-arytenoids**; cut through their attachment to the cricoid, and reflecting them from below upwards note that they are attached above to the external angles of two cartilages, the **arytenoid cartilages**, placed on the posterior upper edge of the cricoid cartilage.
6. Carefully clear away the tissue from the back of the arytenoid cartilages above the cricoid, and observe on the posterior surface of the former the **arytenoid muscle**; cutting it through the middle, which in the sheep is frequently tendinous, reflect it on either side; it will be seen to be attached to the back of each arytenoid cartilage; the posterior surface of the arytenoid cartilage will now be laid bare, and its articulation with the cricoid cartilage can be made out.
7. Looking at the larynx where the thyroid has been cut away, observe the **lateral crico-**

**arytenoid muscle.** Cut away its attachment to the lateral portion of the upper margin of the cricoid, and, reflecting it, observe that it passes backwards and upwards from the cricoid to be inserted into the arytenoid cartilage just in front of the insertion of the posterior crico-arytenoid.

8. Clearing away the fat and connective tissue from the side of the larynx, observe the **thyro-arytenoid muscle** stretching across from the thyroid in front to the arytenoid behind. Cut it through in the middle and reflect both ends. Note its origin from the angle of the thyroid and its insertion into the lateral surface of the arytenoid in front of the insertion of the lateral crico-arytenoid.

Remove the muscle altogether, and observe the lateral surface of the arytenoid cartilage.

9. Cut away on the same side the underlying mucous membrane; the interior of the larynx will now be laid open. On the opposite side the indistinct vocal cord will be seen passing as a pale band of tissue from the anterior angle of the arytenoid cartilage to the angle of the thyroid. The inner or median surfaces of the arytenoid cartilages will be seen to bound a large oval space, called the respiratory space.
10. Clear away on one side any muscle or connective tissue still attached to the arytenoid cartilage, and observe more fully its shape, noting particularly the anterior projection or processus

vocalis, the posterior lateral projection or processus muscularis, and the articulation with the cricoid.

11. Dissect *from the inside* the thyro-arytenoid muscle of the opposite side, and observe more carefully its attachments (§ 8).

The larynx of the sheep differs materially from that of man, by the indistinctness of the vocal cords, by the absence of the false vocal cords and ventricles of the larynx, and by the peculiar crested conformation of the arytenoid cartilages.

### DEMONSTRATION.

The use of the laryngoscope.

## LESSON XXXII.

### TISSUES OF REPRODUCTION.

#### A. OVARY.

1. Take an ovary of a mammal, *e.g.* cat, hardened in a mixture of equal parts of chromic acid .3 p.c. and 50 p.c. alcohol, and prepare longitudinal sections passing through the hilus. Observe first with a low and then with a high power
  - a. The **germinal epithelium**, consisting of a single layer of short columnar cells covering the surface of the ovary except at the hilus.
  - b. The connective tissue radiating from the hilus throughout the ovary to form the **stroma**; in this many blood vessels are seen; towards the periphery the fibrous tissue largely disappears (*cp.* § 2. *a*); immediately underneath the epithelium the stroma forms a denser layer, the tunica albuginea.
  - c. Small **Graafian follicles** forming a zone a short distance below the germinal epithelium.



- d. Deeper (older) Graafian follicles of various sizes scattered throughout the rest of the stroma, in each of these there is a more or less considerable clear space.
  - e. One or more **corpora lutea** (unless the ovary has been taken from a young animal). The corpora lutea vary greatly in size and appearance according to their age, they consist of radiating bands of stroma, between which are a number of granular polygonal cells; if the corpus luteum is young there will be pigment (from effused blood) in its centre.
2. Observe with a high power
- a. The peripheral parts of the stroma consist chiefly of elongated spindle-shaped cells.
  - b. The small Graafian follicles. Note in these
    - a. The **ovum**, large and spherical, within it lies a comparatively large spherical nucleus, the **germinal vesicle**, in which may be seen a nucleolus, the **germinal spot**.
    - $\beta$ . The **membrana granulosa**, a layer of flattened epithelium cells immediately surrounding the ovum.
    - $\gamma$ . The thin *membrana propria* enclosing the *membrana granulosa*.

In the smallest Graafian follicles the *membrana propria* will not be seen, in the larger ones the

cells of the *membrana granulosa* become cubical or short columnar and the ovum has a membrane, the *zona pellucida*.

- c. The large Graafian follicles. Note in these
- a. The stroma investment of the follicles, consisting chiefly of spindle-shaped cells, partly of fine fibrous tissue; inside this is the *membrana propria*.
  - β. The *membrana granulosa*, several cells deep, those next the *membrana propria* being short columnar cells, the rest flattened polyhedral cells.
  - γ. The central space of the follicle.
  - δ. The **cumulus proligerus** projecting into the space; it consists of a mass of cells much like those of the *membrana granulosa* and continuous with them, and it encloses
  - ε. The ovum, like the ovum of the small Graafian follicles but with all its parts larger and its cell-substance (beginning vitellus) more granular; it has further a distinct investing membrane which in some is much thickened so as to form a **zona pellucida**; from this the cell-substance frequently shrinks in the process of hardening. The cells of the *cumulus* which lie next the *zona pellucida* are frequently arranged in a radiating manner.

Probably most of the stages between the smallest and the largest follicles will be seen in the specimen.

- d.* Granular polyhedral cells in the stroma something like those that occur in the interstitial tissue of the testis.
  - e.* In some of the sections taken near the hilus there may be seen lying in the stroma groups of tubules, lined with a short cubical or flattened epithelium, and cut at various angles. These are the tubules of the *parovarium*.
3. Take the fresh ovary of a sheep or large dog; observe the bulgings due to the more or less ripe Graafian follicles. Holding the ovary over a glass slide, carefully prick the most prominent follicle and receive the contents on a glass slide. Examine *without a cover slip*, with simple lens or low objective. If the ovum is present it will at once be recognized. When one is obtained carefully cover with a cover slip, inserting a ring of paper in order to *avoid pressure*, and examine with a high power. Observe
- a.* The thick zona pellucida, with double contour (and radiating striation).
  - b.* The granular cell-substance (vitellus).
  - c.* The transparent germinal vesicle, with its germinal spot. If the follicle be quite ripe these may have disappeared.
  - d.* The cells of the cumulus proligerus attached all round the zona pellucida.

## B. UTERUS.

1. Prepare transverse sections of the fundus of a mammalian uterus which has been hardened in the chromic acid and spirit mixture. The uterus may have been either distended with the fluid, or pinned out and placed in it. Observe
  - a. The thin external fibrous coat.
  - $\beta$ . The thin outer muscular coat of two layers, an outer longitudinal and an inner circular. Inside this and separated from it by a little connective tissue is
  - $\gamma$ . The thick inner muscular coat of two layers, the outer longitudinal or oblique, the inner circular.
  - $\delta$ . The mucous membrane, consisting of fine, loose connective tissue into which run tubular glands from the surface; the glands are lined by a single layer of columnar ciliated cells. The surface of the mucous membrane is covered by similar columnar ciliated cells with some mucous cells.

## C. TESTIS.

1. Take a small mammalian testis, *e.g.* of a guinea-pig, which has been hardened in Müller's fluid, and cut longitudinal sections through the testis and head of the epididymis. Observe under a low power
  - a. The **tunica vaginalis propria**, which is

round the greater part of the testis firmly connected with the underlying tissue, and is hence called the tunica adnata. It separates from the testis near the epididymis.

- b. The **tunica albuginea**, the thick investment proper of the testis; near the epididymis it is very much thickened, forming the **corpus Highmori**; from this radiate bands of connective tissue towards the rest of the albuginea, forming imperfect septa which divide the testis into lobules.
- c. The **tubuli seminiferi**, contorted and anastomosing tubes occupying the lobular spaces; near the corpus Highmori the tubes unite, and the tubes so formed, the **vasa recta**, have a short, tolerably straight course; in the corpus Highmori they anastomose with one another, forming the **rete testis**; from the outer edge of this may be seen some larger tubes, the **vasa efferentia**, which originate from the rete and after coiling in the coni vasculosi join to form the **canal** of the **epididymis**.

2. Observe under a high power

- a. The fine connective tissue of the tunica adnata, indications of the flattened epithelium covering it will be seen.
- b. The coarser connective tissue of the tunica albuginea, corpus Highmori and septa, containing numerous blood-vessels.

- c. The bands and lamellæ of fine connective tissue running from the septa between the tubuli seminiferi.
- d. Polyhedral granular cells scattered about in the tissue between the tubuli seminiferi. These are very numerous in some animals, and to see them in number, a section of the lobular part of the testis of a pig should be cut.
- e. The tubuli seminiferi. In these note
- a. The membrana propria; in some animals this is thick and is formed of several layers of flattened cells.
- β. Tubes lined by cells lying three or four deep and arranged as an inner single layer of short columnar and flattened polyhedral cells, and an outer layer of less regular cells two to three deep. Amongst the cells much larger ones may sometimes be seen.
- γ. Tubes like the above but with the outlines of the cells bordering the lumen less distinct and with bundles of spermatozoa imbedded amongst them. In different tubes the spermatozoa are in different stages of development; in all cases their heads (more deeply stained) are in the peripheral parts of the tubes and their tails directed to the lumen.

- f.* The vasa recta; the tubes have a single layer of cubical or flattened cells.
  - g.* The rete testis; the membrana propria of the tubes disappears, the epithelium is rather more flattened than in the vasa recta.
  - h.* The vasa efferentia and canal of the epididymis;
    - a.* The external fibrous coat.
    - β.* Inside this a coat of circularly arranged unstriated muscle.
    - γ.* The epithelium consisting of columnar ciliated cells with some small cells between or outside their peripheral ends near the basement membrane. In the canal of the epididymis the ciliated columnar cells are long and slender. Masses of spermatozoa may sometimes be seen in the lumina of the tubes.
3. Cut a transverse section of the vas deferens and compare with the sections of the canal of the epididymis.
- a.* The wall is very much thicker, this being chiefly due to a great increase in the muscular coat; there is a longitudinal muscular coat outside the circular coat.
  - b.* The epithelium consists of non-ciliated columnar cells with one or more layers of small peripheral cells; between the cells and the muscular coat is a layer of fine connective tissue (mucous coat).

4. Tease out in dilute glycerine a fragment of a testis which has been placed in osmic acid .5 p.c. for a day and observe the cells and developing spermatozoa of the tubuli seminiferi.
5. Cut in half the fresh testis of a rat, and gently press the cut surface on a glass slide. Observe the spermatozoa, each consisting of
  - a. An ovoid head or body.
  - b. A long tapering tail or process.
  - c. A short intermediate part.Note that the spermatozoa move by a whip-like movement of their tails.
6. Observe in like manner the spermatozoa of a newt. The head is long and pointed, the intermediate part small and not very distinct; from the intermediate part starts a filament which runs in a spiral around the long tail; the filament is in reality the edge of a thin spiral membrane, but this is difficult to make out.





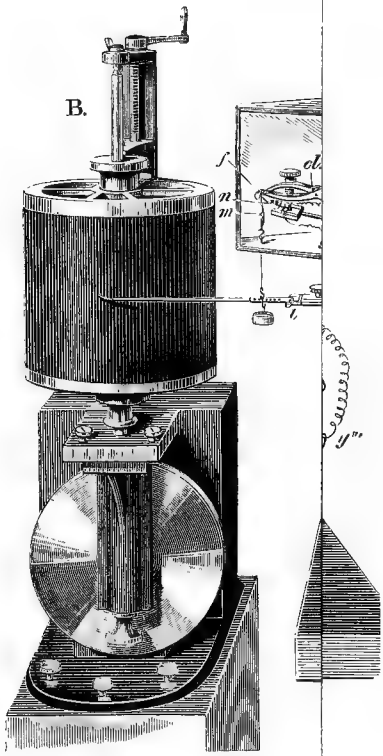

B.

s

ct

m

n

1/2"

## APPENDIX.

### DESCRIPTION OF INSTRUMENTS USED IN LESSON IX.

**du Bois Reymond's Key.** This is shewn at *C*, Fig. 1. (See end of Appendix.) Note the arrangement of the wires; when the key is closed the current passes across the key and an infinitesimal part only passes by the electrodes through the alternative circuit; in the text this is called 'arrangement of key for short-circuiting the current.' If two wires only are connected with the key, one on either side, the current cannot pass when the key is open, but can when the key is closed; in the text this is called 'arrangement of key to break the current.'

**Morse Key.** This is shewn at *F*, Fig. 1. The connecting wires of a Morse key are hidden by the framework. The following diagram (Fig. 2) will shew the way in which they are usually arranged.

It is obvious that with wires arranged as at *F*, Fig. 1, the current can pass from *a* to *b*, except when the end *x* of the lever is pressed down (cp. Fig. 2), then the circuit is broken; if the wires are connected with *b* and *c*, the current cannot pass until the end *x* of

the lever is put down (arrangement of key to break

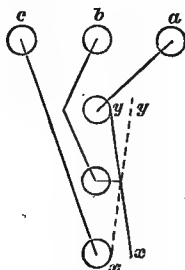

FIG. 2.

the current); lastly, if the wires from the battery are connected with *a* and *b* respectively, and the wires of the electrodes with *a* and *c* respectively, then the current passes across the key until the end *x* of the lever is pressed down when the current is thrown into the electrodes (arrangement of key for short-circuiting the current)

**du Bois Reymond's Induction Machine.** This is shewn at *D*, Fig. 1. The screws at the top of the machine are connected with the ends of the wire forming the primary coil; consequently, when the battery wires are connected with these screws, each break and each make of the circuit produces an induction current in the secondary coil; the make and break can be most simply effected by means of a key placed in the primary circuit and arranged to break the current (cp. above); in the text this is called the arrangement for single induction shocks.

When the wires from the battery are connected with

the screws of the two pillars at the front end of the machine, cp. Fig. 3, then the current of the primary circuit is rapidly made and broken, and a corresponding number of induction shocks produced in the secondary coil. The method in which the primary current is made and broken will be easily understood from the figure. When the current is passing in the primary coil, (b) is in contact with (c), but since the

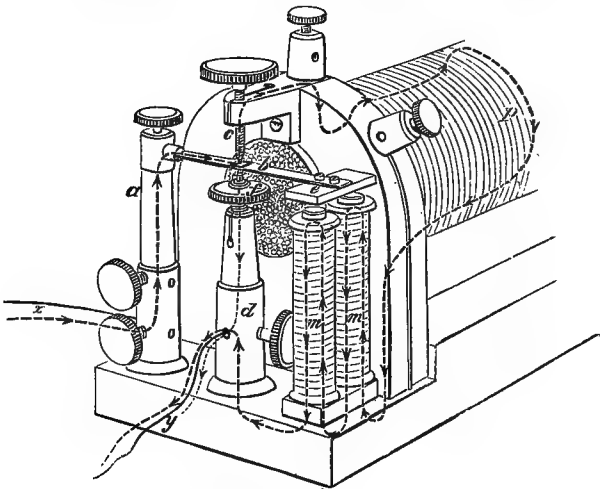

FIG. 3.

current also passes round the coil (*m*) the soft iron core of this coil becomes magnetized, and consequently attracts the plate (*e*); as this goes down the contact of (*b*) and (*e*) is broken, hence the current ceases to pass in the primary coil, the core of (*m*) is no longer magnetized, the plate (*e*) flies up, (*b*) comes again in contact with (*c*) and the cycle

of events starts again; in the text this is called the arrangement for the interrupted current.

### Moist Chamber.

One form of moist chamber is shewn at *A*, Fig. 1. In arranging a nerve-muscle preparation in it the femur (*f*) is clamped (*cl*), a hook is passed through the lower tendon of the muscle, the hook is connected with another hook fastened to the lever, and the lever by means of its screw is shifted up or down to bring it in a horizontal position. Moist blotting-paper should be placed on the floor of the chamber, further the nerve should be covered with blotting-paper moistened with normal salt solution.

The nerve is placed across electrodes such as those shewn in Fig. 4.

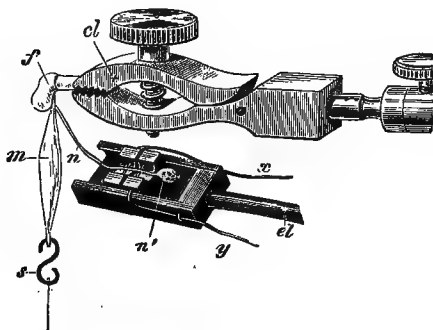

FIG. 4.

### Non-polarizable electrodes.

One form of these is given in Fig. 5; the pointed end (*ch. c*) of the glass tube is filled with china clay worked into a stiff mass with normal salt solution;

a little saturated solution of zinc sulphate (*z. s.*) is poured with a fine pipette into tube above the plug of clay; into the zinc sulphate solution dips the thoroughly amalgamated end of a thin rod of zinc.

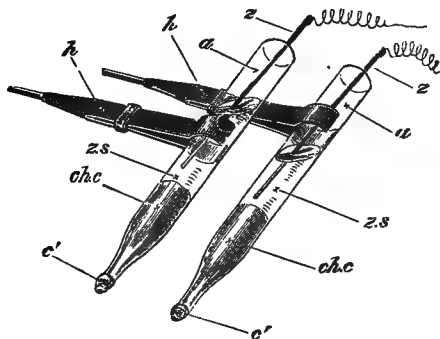

FIG. 5.

### Oscillating rod.

This is a thin band of steel about 9 inches long and  $\frac{3}{4}$  in. wide; at one end at right angles to the band is fixed a pointer one to two inches long. The band can be fixed at any part of its length by a wide brass clamp; connected with the clamp is a binding screw. A cup containing mercury is placed underneath the pointer and the clamp is arranged on the stand at such a height that when the band descends in oscillation, the pointer dips a millimetre or so into the mercury; it is well to cover the mercury with a thin layer of alcohol. A piece of main-spring bent at one end will serve the purpose of the steel band.

### Lever for the Frog's Heart.

The lever used is like that given at (*l*) Fig. 1, but

a thin vertical needle is attached to it at the place where the weight hangs in the Figure, at the end of the needle is fixed a small piece of cork which rests on the ventricle, the frog lying on a stage below the lever.

### Time Marker.

The two ends ( $w, w'$ ) of the wire wound round the bobbins ( $b, b'$ ) are connected with the binding screws ( $sc, sc'$ ). In using the instrument one binding screw is connected with one of the poles of a galvanic battery, the other binding screw with a clock or metronome from which runs a wire to the other pole of the battery. The clock or metronome is arranged so that it makes and breaks the circuit at regular intervals. When the circuit is made the current passes round the bobbins, the soft core of the bobbins becomes magnetized and the lever ( $l$ ) is drawn down; when the circuit is broken the lever is drawn away from the bobbins by the spring ( $sp$ ). At the end of the lever is fixed a stiff bristle (to write on smoked paper) or a small bent glass tube filled with magenta dissolved in dilute glycerine (to write on glazed paper).

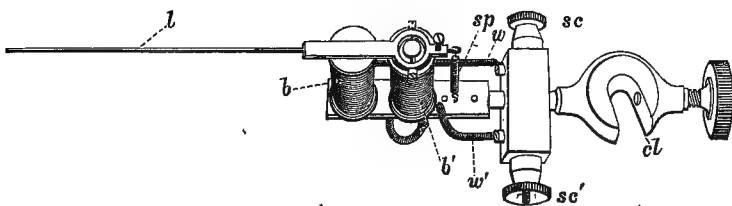

FIG. 6.



## NOTES ON THE USE OF THE MICROSCOPE.

See that the tube of the microscope moves easily, but not too easily, up and down. It should occasionally be rubbed round with a little olive-oil, and the oil then wiped off with a dry cloth.

With a piece of soft chamois leather or silk, remove any dust that may be on the lenses of the eye-piece or on the lower lens of the objective. If by accident the objective has been smeared with glycerine, stream it with water from a wash-bottle, and wipe it dry with chamois leather: if with Canada balsam, place on it a drop of chloroform or strong spirit, and rub gently, repeating till the balsam is quite removed: this must be done very cautiously, since the lenses are sometimes fixed in with Canada balsam.

All *unnecessary* rubbing of lenses however should be avoided; hence take care to put them away after they have been used.

It is advisable for the student not to unscrew the separate lenses of a high objective; when however the dimness of an object under observation renders it necessary to do so, care must be taken not to remove the black coating on the inside of the tube in cleaning the lenses, and when cleaned to restore them, in proper order, to their previous positions.

With a low power (cp. foot-note, p. 35), twist down the microscope-tube till it is rather less than a quarter of an inch from the object; then looking through the eye-piece, twist the tube *upwards* till the specimen is in focus.

With a high power, lower the tube till it is  $\frac{1}{8}$  of an inch from the object, and then slowly twist the tube down, moving the slide about, till the object just becomes visible, then focus by means of the fine adjustment.

Direct sunlight should not be used to illuminate the field; in selecting a permanent position to work with the microscope, it is best to face the north.

With high powers, use the corresponding small diaphragm; otherwise although the field may look brighter, the outlines of the cells, etc. will not be so well defined.

The student should accustom himself to keep *both* eyes open when using the microscope, and to use *either* the right or the left eye for looking at specimens. The fatigue of microscope work is thus very much lessened. It generally requires a little practice to keep both eyes open, but a few minutes' trial every time that the microscope is used will soon overcome the difficulty.

When an object appears dim, it may be caused by some fault in the specimen itself, or by the object-glass not being clean. In the latter case the dimness remains, whether the object is in focus or not. Dust upon the lenses of the eye-piece can be recognized by the outlines of the particles appearing well defined, not dim and diffuse.

### **Zeiss' camera lucida.**

The ring (*r*) Fig. 7, is slipped over the tube of the microscope (*t*), and the ocular (*o*) inserted; the object to be drawn is focussed, and the prisms are brought over the ocular in the position shewn in Fig. 7. (The upper part of the figure represents a side view; the

lower, a view from above, of the camera arranged for use). The edge (*a*) of the prism of the side *A* of the camera covering half of the upper lens of the ocular.

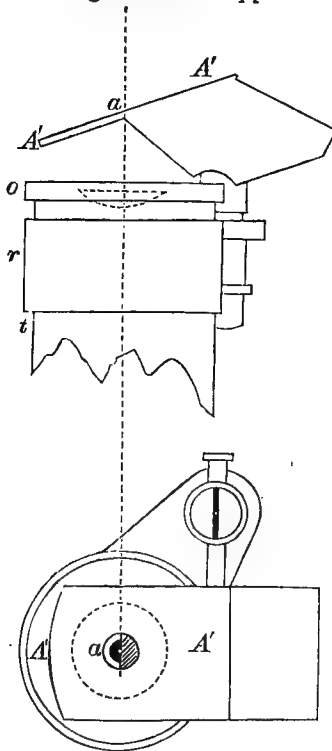

FIG. 7.

In front of the microscope, the drawing-board is placed at an angle of  $15-20^\circ$  with the surface of the table. On looking down the microscope both the object and the drawing-board are seen. The illumination of the drawing-board and of the field of the microscope

should be about equal, so that the point of a pencil on the drawing surface is distinctly seen.

### Measurement of the size of microscopic objects.

The method of doing this which has been given in the text (p. 37, § 3) involves making a drawing of the object; when this is not done the size of the object may be measured by means of an *ocular micrometer*. This is a flat piece of glass on which a scale is scratched (e.g. 5 mm. divided into ten parts, the actual distances of the lines are however not important), this is dropped into the ocular so that it rests on a ledge placed on a level with the focus of the upper lens of the eye-piece. With this scale in the eye-piece the stage micrometer (cp. p. 37, § 3) is observed, and the number of divisions of the stage micrometer which correspond to one division of the ocular micrometer noted. Say that one division of the one exactly covers one division of the other, then if (as is usually the case) one division of the stage micrometer is  $\frac{1}{100}$  mm. one division of the ocular micrometer, with the objective, ocular and length of draw-tube used; corresponds to  $\frac{1}{100}$  mm. of the field of the microscope. Hence any object seen with this arrangement of the microscope can be at once measured by the ocular micrometer, an object which exactly occupies say 5 divisions measures in that direction exactly  $\frac{5}{100}$  mm.

If another ocular or objective be used, or if the tube be drawn out, the divisions of the ocular micrometer will obviously correspond to a different number of divisions of the stage micrometer, so that the value of the divisions of the ocular micrometer must be determined for each arrangement of the microscope.

Supposing the value of the divisions of the ocular micrometer are known with any given arrangement of the microscope, then the magnification of any object drawn can easily be measured; suppose for example that the drawing measures 5 mm. and the object itself with the given arrangement of the microscope occupies 5 divisions of the ocular micrometer, the value of each division being  $\frac{1}{100}$  mm., then in the drawing the object is magnified  $5 \div \frac{5}{100} = 100$  times.

The **magnifying power** of a microscope with any given ocular, objective, and length of draw-tube, is usually taken as the amount of magnification when the image of the object is seen at a distance of 25 centimetres (10 inches) from the eye. To determine this, the stage micrometer lines are drawn at this distance and the distance between these lines is measured; thus if one division of the stage micrometer equal  $\frac{1}{100}$  mm., and the drawing of this measures exactly 1 millimetre, then the magnifying power is 100. In order to compare the tables given by different instrument makers of the magnifying powers of their microscopes, it is necessary to know the method used in determining it; in all cases when an object is drawn its magnification should be determined by the method given above or by that given in the text.

#### OBSERVATION OF FRESH TISSUES.

Sections of fresh tissues may be made with the aid of a freezing microtome (cp. p. 368); if, however, specimens can be prepared without freezing, it is

generally better to do so. Such specimens may be prepared in various ways.

A few parts of the body, e.g. the kidney, are sufficiently thin to allow sections to be cut free-hand with a razor ; one section should be mounted without adding any fluid, another in a normal solution, and a third should be teased out in a normal solution.

With structures too yielding to cut sections, e.g. the villi of the small intestine, a piece may be snipped off with scissors ; in the same way a good specimen may often be obtained from the edge of a lobule of a gland : in some cases, e.g. the coat of an artery, a strip may be torn off with forceps ; and in the case of membranous structures, a piece may be pinned out over a hole in a stage, the gastric glands and pancreas of some animals for example may be thus observed.

The knowledge gained by the examination of such specimens is essential to thoroughly understanding the appearances presented by the tissue after the action of reagents.

There are certain fluids which, when fresh, cause very slight changes in the tissues ; they more or less resemble the fluids with which the tissues in the body are surrounded.

These **normal fluids** are

- a. The aqueous humour of the eye.
- b. Blood-serum.

If, then, a fresh tissue is to be observed from e.g. a rabbit, the corneæ should be punctured to obtain the aqueous humour, or the blood should be allowed to

clot in a vessel, to obtain the serum. In one of these fluids the tissue should be mounted.

c. Normal saline solution.

This is prepared by dissolving 6 grm. of sodium chloride (pure if obtainable) in 1000 c.c. of distilled water. This is for some tissues rather better than the .75 p.c. solution which is often used, but in many cases there is nothing to choose between the two solutions.

d. Iodized serum.

Iodine is sometimes added to serum to preserve it, so that it may be at hand when required; serum thus iodized is, however, far less a 'normal' fluid than the others. It may be prepared by dropping a few crystals of iodine into fresh serum, and shaking occasionally. The fluid should be of a light brown colour. Instead of serum the amniotic fluid of the cow may be taken.

## Teasing.

Be careful to take a *small* piece only: it should be viewed with a low power before teasing, to ascertain the general relation of the parts, and hence to guide the teasing: thus, if it consists of parallel fibres, with one needle fix the piece at one corner and draw the other needle through it in the direction of the fibres; in teasing out to shew special objects, e.g. ganglion-cells, the arrangement of the parts should be *particularly* noticed under a low power, and such pieces as do not contain the parts required should be thrown away.

In teasing, it is important to place the slide on an

appropriate ground; if the object is white or grey, the slide should be placed on a piece of black paper; if it is dark, on a piece of white paper. Stained sections should also be teased out against a white or grey ground.

#### DISSOCIATING FLUIDS.

These are fluids which, whilst preserving certain parts of a tissue, dissolve or partially dissolve others, principally the cementing or ground substances, so that the former can be isolated by teasing or shaking. As a rule the piece of tissue so treated should be not more than one to two mm. square.

*Weak iodized serum* of a light brown colour is in most cases the best. As the tissue absorbs the iodine, a little strongly iodized serum should be added; or the fluid renewed. The tissue may often be teased out after one day; but a longer time may be necessary.

*Osmic acid*, .1 to 1 p.c., is a dissociating fluid of general application; it has the advantage of altering the normal appearances in most cases very slightly. It swells up some nuclei, and also the axis cylinders of nerves.

*Dilute alcohol* (30 to 35 p.c.) is also good for many tissues.

The following agents are also used, the tissues for which they are most recommended are put in brackets; baryta water (fibrillæ of white fibrous tissue); 5 p.c. neutral ammonium chromate (mucous glands); .02 p.c. potassium bichromate (muscle and nerve-cells); .02 p.c. chromic acid (nerve-cells of spinal cord); Muller's fluid (olfactory cells); 5 p.c. chloral



hydrate (serous glands). As a rule it is best to tease out the tissues in the fluid in which they have been placed, they may also be teased in water or in dilute glycerine; if mounted in water they may be temporarily preserved by heating the end of a small wax taper in a flame, and with the wick smearing the wax round the cover-slip.

## HARDENING AGENTS.

### General Directions.

The tissues should be removed from the body to the hardening agent as soon as possible after the death of the animal.

Any blood which may be on the piece of tissue should be removed by shaking gently in salt solution or by placing on blotting-paper.

Divide the tissue (with a razor or sharp scalpel) into *small* pieces before placing in the hardening fluid. As a rule the pieces should not be more than 3 to 4 mm. square. Since the brain is too soft to allow it to be easily cut up without injury in the fresh state, it is generally placed whole in the hardening fluid, but in this way the deeper parts of the cortex are in large brains rarely well preserved (cp. foot-note, p. 327).

In all cases where a tissue is put in a fluid to harden or have lime-salts extracted from it, the fluid in which it is placed should be relatively abundant, e.g. 15 to 20 times the volume of the tissue; it should be renewed after a time varying from 12 to 24 hours.

When the tissue is well hardened, the hardening agent should be extracted from it by placing it in alcohol, first dilute 30 p.c. to 50 p.c. then stronger 50 p.c. to 75 p.c. ; it should then be preserved in 70 to 95 p.c. alcohol.

Since chromic acid, potassium bichromate, etc., are precipitated by alcohol in the light, tissues hardened in these reagents, after being washed with water and placed in alcohol, should be kept in the dark, until required for cutting, or until the alcohol, frequently renewed, no longer becomes yellow. Many tissues when well hardened may be left a day or more in water without injury before placing in dilute alcohol. Tissues hardened in picric acid are best placed an hour or two only in the dilute alcoholic solutions, and then transferred to 70 to 95 p.c. alcohol, which may be renewed as often as it becomes coloured.

The tissues should be placed in a flat short bottle to harden, rather than in a narrow high one; they should be kept *cool* during the first day or two, after this it is of less importance, though usually advantageous.

### Preparation of Solutions.

It is generally advisable to make of any given substance a solution of the maximum strength likely to be required, and to dilute this when weaker solutions are needed. If the stronger solution contains  $x$  p.c. of the substance and it is required to make a weaker solution of  $y$  p.c., add  $\frac{x}{y} - 1$  c.c. of water to each c.c. of the stronger solution.

It is rather better to use distilled water in making up

the solutions, but in most cases this is not of much importance.

**Chromic acid.** Dissolve 5 grms. in a litre of water, from this the .3 and .2 p.c. solutions which are more frequently used can readily be prepared.

A little chromic acid may often be added with advantage to potassium bichromate and ammonium bichromate solutions; it may also be used mixed in various proportions with picric acid.

Chromic acid hardens the tissues by an action analogous to tanning; but renders them, if they are left in it too long, brittle and friable.

**Chromic acid and spirit.** Mix two parts of chromic acid  $\frac{1}{8}$  p.c. with 1 part of methylated spirit (Klein),  
or

Mix equal parts of chromic acid .3 p.c. and alcohol 50 p.c.

These solutions may require to be filtered before they are used, they should be kept in the dark. It is better to make them when required.

**Erlicki's fluid.** Dissolve 2.5 grms. of potassium bichromate and .5 gm. cupric sulphate in 100 c.c. water. This is sometimes useful when a quicker hardening agent than the chromium compounds alone is required; after two days the fluid with the tissue may be kept at about 40° C. to increase the rate of hardening.

### **Extraction of salts from bone.**

The bone should be divided into small pieces and

placed in a large quantity of chromic acid .1 p.c. It is well to shake gently occasionally, in order to bring fresh acid in contact with the bone. The fluid should be renewed in 24 hours, and changed for .25 p.c. acid in about two days. After a week a solution of .5 p.c. may be used. This also may with advantage be changed once or twice. The decalcification of fully developed bone will take about a fortnight, but a preliminary section should be made from one end with a blunt razor or scalpel to see that all salts are extracted.

To hasten the solution of the salts, 1 c.c. of nitric acid may be added to each 100 c.c. of the chromic acid solution, but this should only be used when the tissue has been for 2 to 3 days in the dilute chromic acid; as soon as the salts are dissolved the tissue should be transferred to alcohol.

Instead of chromic acid, picric acid (either Kleinenberg's or a saturated aqueous solution) may be used, or the tissue may be placed in strong spirit for a day or two and the salts then extracted with nitric acid 1 to 4 p.c.; as soon as this is complete the tissue should be replaced in spirit. A mixture of nitric acid 1 to 3 p.c. and strong spirit is often useful to complete the solution of salts in tissues which have been hardened in chromic acid but from which the salts have been only partially extracted.

**Müller's fluid.** Dissolve .25 grms. of potassium bichromate and 10 grms. of sodium sulphate in 1000 c.c. of water.

**Picric acid.** Make a cold saturated solution of picric

acid, and to 100 c.c. of this add 2 c.c. of concentrated sulphuric acid; filter, and to the filtrate add 300 c.c. of distilled water (Kleinenberg).

Tissues should be left in this for a comparatively short time, varying from three hours to a few days; the hardening may be completed with alcohol. If the tissue contains earthy salts to be extracted, nitric acid should be substituted for sulphuric acid.

A simple concentrated aqueous solution is also frequently useful.

**Osmic acid.** A 1 p.c. solution of this is most useful. To avoid reduction of the osmic acid care should be taken to obtain water free from organic matter. The acid is obtained in tubes containing one grm. each, the tube should be well washed and then broken in a bottle containing 100 c.c. of distilled water and shaken occasionally; it takes some little time to dissolve completely. The bottle should have been previously well washed with sodium hydrate, sulphuric acid and water. If a solution is required to be made at once, the tube with the osmic acid may be ground up in a mortar with a little water, but some care is required to do this without suffering from the hurtful vapour. If the solution begins to turn brown, the bottle should be covered with black paper and kept in the dark; this however should not be necessary. Osmic acid does not penetrate well, so that a small piece only of the tissue should be taken; the tissue may be left in the osmic acid any time from half-an-hour to a day, in the latter case a .5 p.c. solution should be used. Many tissues are hardened sufficiently by a stay of 12 to 24 hours in osmic acid to allow of

sections being at once cut ; if they are to be imbedded they should be washed with water and placed for a quarter of an hour or more in 30 p.c., 50 p.c. and 70 p.c. alcohol. When the tissues are to be kept some time before cutting, they should be *well* washed with water and then treated with alcohol as chromic acid specimens are treated ; of course if the tissue has not been sufficiently hardened by the osmic acid, its stay in dilute alcohol must be short. The tissues become very much darker on staying in alcohol ; it is not advisable to leave them long in this fluid before sections are made. In osmic acid specimens the nuclei are generally spherical and indistinct although the nucleoli are not infrequently obvious. The longer a tissue is left in osmic acid, the less easily does it stain with carmine and other reagents.

Osmic acid specimens which it is desired to preserve should be mounted in dilute glycerine or in a concentrated aqueous solution of acetate of potash ; they may, though with less satisfactory results, be cleared and mounted in Canada balsam.

## Alcohol.

Alcohol, besides its general use of completing the hardening begun by other fluids, is sometimes used alone. It coagulates the albumin in tissues and thus renders them more opaque.

It is generally best to place the piece of tissue for half-an-hour to an hour in 75 p.c. alcohol, and then to remove it to strong spirit (90. to 95 p.c.) ; in some cases it is advantageous after the tissue has been half-an-hour in strong spirit to transfer it to absolute alcohol. Absolute alcohol when

used alone usually causes more or less shrinking and distortion of the outer parts of the tissue; in such case the inner part only should be taken in preparing sections.

### IMBEDDING.

Take a *small* piece of tissue only to imbed; of course this cannot be done in many cases, where it is desired to make out the general relation of the parts of an organ; it is moreover of comparatively little importance when the sections are to be cut with a microtome.

Before imbedding (cp. p. 68) press the piece of tissue very gently between blotting-paper, to remove as much as possible of the fluid in which it has been placed. The fluid, if not removed, cools the imbedding mixture immediately round the tissue, and not mixing with it prevents the due adhesion between the mixture and the tissue: with spirit specimens the excess of fluid should not be removed till the imbedding substance, etc., is ready, since the spirit rapidly evaporates, and the tissue may become dry.

The imbedding substance should be heated as little as possible above its melting point. To keep it at a constant temperature, a water-bath heated by a small gas jet with a regulator may with advantage be used.

When the tissue is moved about by means of a heated needle, to place it in position in the embedding substance or to remove air-bubbles, bring down the temperature of the needle to that of the substance by moving the needle about in it before touching the tissue.

The substance in which different tissues should be imbedded varies with the consistency of the tissue. As a rule the imbedding substance should be of about the same degree of hardness as the tissue. Loose tissues, or tissues with cavities, should before imbedding be treated in the manner given on p. 215.

A still simpler method of imbedding than that given on p. 68 is to take a block of paraffin B, to heat a stout wire over a Bunsen flame and with it to melt the central portion of one end of the paraffin block, in this the tissue is placed, it is turned into the proper position and the bubbles are removed by means of the warmed wire; since the wire is very easily made so hot that it would injure the tissue, it should be brought into contact with the tissue as little as possible. This method should only be used for dense tissues.

The paraffin 'blocks' can be made by taking a tube (e.g. of copper) about a foot long and fitted with a piston, the inside of this is oiled a little and the melted imbedding mixture poured into it; it is placed under a tap to solidify the mixture, the column of substance is then pushed out and cut into lengths about an inch and a half long.

The time the tissue should stay in the various agents given on p. 215, varies with its density. With tissues treated in this manner the following method of imbedding will be found better than those previously given. Two L-shaped pieces of lead with sides about half an inch high are placed on a glass slide so that the long limb of each is in contact with the short limb of the other; the enclosed space is about three-fourths filled with the imbedding mixture, a little water



is then poured on the glass to solidify the lower portion of the mixture, and just when a thin crust is forming on the upper surface, the space is filled up with the mixture and the tissue placed in it. The layer next the glass is by this time solid, and on this the tissue can be arranged with a warm needle in any position required.

An oblong box made out of not too thin paper may be used instead of the pieces of lead.

The sections, in this case, are best cut with a razor moistened with olive oil. The imbedding mixture must be dissolved out, e.g. with creosote and turpentine; if it is desired to mount the sections in glycerine, they should be placed in absolute alcohol to remove the creosote and turpentine, they can then be mounted at once or after having been placed in more dilute spirit.

Before cutting sections, cut away the imbedding substance close around the tissue. It is easier to cut thin sections when the surface to be cut is small than when it is large.

In preparing the following mixtures, the constituents should be placed in a capsule on a water-bath and kept at a temperature just above melting point for an hour or more, the liquid being occasionally stirred.

### **Paraffin A.**

Solid paraffin 15 grms.

Liquid paraffin 15 c.c.

This is used to surround the cover-slip in observing the amœboid movements of white blood-corpuscles, on the warm stage. It begins to melt at about

37° C., and thus serves as an indication of the limit of temperature that can be used in the observation without injury.

### **Paraffin B.**

Paraffin 2 parts.

Vaseline 1 part.

This is one of the best imbedding mixtures for general purposes, it can be made harder by adding a little more paraffin.

### **Spermaceti and Castor oil.**

Spermaceti 40 grms.

Castor oil 10 grms.

### **SECTION CUTTING.**

In order to make thin sections it is absolutely necessary to have a sharp razor. It sometimes happens that a student who has resigned himself to the belief that he cannot cut thin sections finds no difficulty in doing so on buying a new razor.

In carrying on a class, where it is required to cut a considerable number of equally good sections, a microtome is almost indispensable; perhaps the most useful for a Demonstrator's purpose is the freezing microtome made by Swift, Optician, Tottenham Court Road, London. The one in which ice and salt is used, is recommended in preference to the one in which ether is used, since it is less liable to get out of order, and when once started will continue freezing for two to three and a half hours. Equal parts of ice and salt are taken, and pounded up together in a mortar, then packed tightly in the box of the microtome.

Tissues to be cut with the freezing microtome are soaked in gum ; if they have been kept in strong spirit, they should be placed for a short time in weak spirit, and for an hour or more in water, before being placed in the gum ; it is best to let them soak in the gum for a day ; but sections may be made, though probably less good, after a very short period of soaking ; in this case the crystals of ice, which form, rapidly blunt the razor.

The gum solution is prepared by dissolving gum arabic in warm water, and filtering through linen ; a rather thin solution may be used to soak the tissue in, a thicker one to surround the tissue on the microtome. Since gum alone freezes into a hard mass, a little sugar solution may with advantage be added to it.

The plate of the microtome, and the grooves in it, must be quite clean ; a layer of gum is then spread over it, care being taken that the gum fills up the grooves. When the tissue has become frozen on the plate of the microtome, the gum around it should be bevelled off so that the section to be cut is not much larger than the piece of tissue.

A hollow ground razor should not be used, since it bends, and so makes a section, which, under the microscope will be found to consist of bands of unequal thickness.

The proper rate to carry the razor through the tissue varies with the temperature of the frozen mass ; when it is a few degrees only below zero, the movement may be the quickest possible ; when it is frozen hard, it should be carried slowly through the tissue, otherwise the sections are apt to curl or break up.

In cutting not very large sections, a dozen or more sections may be cut in rapid succession; the sections heap up on the razor, and may be removed to water with a camel-hair brush; three or more pieces of a well hardened tissue may thus be cut simultaneously. In cutting large sections, it is best to place on the razor a number of small drops of water and to cut slowly; the section folds up on the razor. The razor (with the frame) should then be dipped under water and the section floated off; it should be taken out on a glass slide and treated on the slide with 30, 50, 75 p.c. alcohol, etc.; care should be taken to remove as much as possible of the clearing agent, otherwise the Canada balsam in which the section is mounted may remain a long time fluid. Smaller sections should be treated in the glass dish or watch glass-with the various reagents.

Sections of imbedded tissues may also be cut with the microtome, but as a rule this is more trouble than, and has no advantage over, the freezing method.

Fresh tissues should be frozen as little as possible below  $0^{\circ}\text{C}$ ., they are apt to shew crossing bands brought about by the crystallization of the water in them; they should be transferred with a brush to salt solution. If it is required to stain them they should be transferred to 30 p.c. alcohol and treated with Spiller's purple, methylene blue or methyl-violet or removed from 30 p.c. to stronger alcohol and stained with carmine, hæmatoxylin, etc.

When one or two tissues only are to be cut, it is simpler to use a microtome with ether spray as the

freezing agent; Swift's ether freezing microtome may be used.

## STAINING.

### Hæmatoxylin.

- a. 1. *Kleinenberg's hæmatoxylin.* Take crystallized calcium chloride, and add it in excess to 70 per cent. alcohol; shake well and let it stand. Draw off the saturated solution and add alum to excess, shake up and let stand for a day. Filter.
2. To one volume of the filtrate from (1) add six to eight volumes of 70 p.c. alcohol.
3. To the mixture thus obtained, add drop by drop a saturated solution of hæmatoxylin in absolute alcohol, till it is a *moderately* dark purple.

The solution will become considerably darker after some days. It is better to make it some weeks, or even months, before it is required for use.

It may be diluted to any extent required with the mixture (2). If a section is placed in hæmatoxylin for some time it must of course be covered up, or the spirit will evaporate, and the solution become concentrated. In many cases it is well to stain a piece of tissue as a whole in hæmatoxylin before imbedding, in this case the tissue should be left in the diluted fluid one to two days; a tolerably porous tissue naturally serves best for this method. A small piece only should be taken.

It is perhaps best to wash tissues or sections stained with hæmatoxylin in the diluting fluid (2); they may however be washed with alcohol (best about 70 p. c.); if it is desired to stain more particularly the nuclei, the stained tissue may be placed for a short time in a mixture of 2 parts alcohol (70 p. c.) and 1 part 1 p. c. hydrochloric or nitric acid.

If a section, which it is wished to preserve, has been stained too deeply, the colour may be partially extracted by placing the section in dilute acetic acid. If the sections are washed with water, *distilled* water must be used, otherwise alumina may be precipitated.

The hæmatoxylin after it has been used should be put aside in a separate bottle, since after filtration it may be used again. If it has been mixed with acid, it will have a reddish tint and will be useless; the acid may be neutralized with sodium carbonate, but the mixture rarely stains so well as the original solution.

- b. *Alum-hæmatoxylin.* To a .3 to .5 p.c. solution of alum, add a few drops of a saturated solution of hæmatoxylin in absolute alcohol.
- c. *Alum-logwood.* Place in a mortar 5 to 10 grms. of alum, 5 grms. extract of logwood, and 100 c.c. of water, grind well, leave for a day and filter.

To both (b) and (c) a little thymol or salicylic acid should be added, both should be filtered before being used; these solutions stain well the nuclei of sections of most tissues, but they cannot be satisfactorily used for staining pieces of tissue before sections are made.

**Carmine.** (Frey's method.)

a.	Carmine	0·3	gram.
	Glycerine	30·0	„
	Alcohol	4·0	„
	Distilled water	30·0	„
	Ammonia	q. s.	

Add the distilled water to the carmine, and then add dilute ammonia drop by drop until the carmine is dissolved, taking care that the least possible excess is added. If the solution smells strongly of ammonia expose it in a flat vessel to the sunlight for a day or two. Finally add the glycerine and alcohol, and shake. It should be kept in a stoppered bottle, since otherwise the ammonia evaporates and the carmine is precipitated.

It may be diluted with water to any extent required. In the *strong* solution tissues hardened in chromic acid or chromium salts may be left for days or weeks without being over-stained.

As a rule sections stain better with carmine when they are left in a dilute solution for 12 to 24 hours.

In another glass, under the same bell-jar as the sections, a little dilute solution of ammonium carbonate may be placed.

If sections are too deeply stained with carmine, or if there is a precipitate of carmine upon them, they should be placed in *very* dilute ammonia and gently moved about in it; as soon as the excess of carmine is removed, they should be poured into a large quantity of water and all trace of ammonia washed away.

Most preparations stained with carmine are best preserved in glycerine containing 1 p. c. formic acid 1·16 Sp. Gr.

### **Picrocarminate of Ammonia or Picrocarmine.**

Prepare a saturated solution of picric acid, and to it add a saturated ammoniacal solution of carmine till a precipitate occurs. Evaporate in a water-bath till the volume is reduced by four-fifths. Filter, and evaporate the filtrate to dryness. A crystalline mass of picrocarmine is thus obtained. It dissolves readily in distilled water; a 1 to 5 p. c. solution should be made, and further diluted as occasion requires.

If the picrocarmine is found to stain sections too yellow, a little Frey's carmine may be added to it, and the mixture filtered.

Most of the yellow colour may however be removed from tissues stained with picrocarmine by repeated washing with water or alcohol.

Picrocarmine after being used may be filtered and used again.

### **Borax carmine.**

Borax	4	parts
Carmine	2·5	„
Water	100	„

Warm until the carmine is dissolved, being careful not to let the mixture boil. When the fluid is cold, add an equal volume of 70 p. c. alcohol and filter.



The proportions of borax and carmine given here are not very important; less carmine and more borax may be used. The fluid may be used without the addition of alcohol, or glycerine may also be added to it; further the precipitate from the alcohol may also be dissolved in water and used.

Borax carmine is principally used when it is desired to stain nuclei deeply; the staining is usually improved by placing the sections for a few minutes in a mixture of 2 parts alcohol and 1 part hydrochloric acid 1 p. c.

### **Spiller's purple and Methylene blue.**

These are used in a strong aqueous solution so that in a minute or two the sections are sufficiently stained, they are then washed with water, and mounted in water; if the staining is too deep, the sections are placed for a short time in alcohol; the sections cannot be mounted satisfactorily in glycerine, since the glycerine dissolves the colouring matter and renders the staining diffuse. To preserve the sections permanently they should be over-stained, then passed rapidly through 30, 50 and 70 p. c. alcohol; they should then be washed with strong spirit (which dissolves the colouring matter very rapidly) until nearly the proper tint is obtained, transferred to absolute alcohol, and in a minute or two to cedar wood oil; when they have become transparent, they are mounted in Canada balsam. Cedar wood oil instead of clove oil is used to clear the sections, since it does not dissolve the colouring matter; water

must be entirely removed from the sections by absolute alcohol.

## Iodine.

Dissolve 2 grms. of iodide of potassium in 100 c.c. of distilled water, and add flakes of iodide to slight excess.

## Gold chloride.

The method of using this for ordinary cases is sufficiently described in the Text, Less. iv. § 3; Less. xxiv. A, § 4. The tissue should be touched with metal as little as possible, it may be removed from one fluid to another with a small brush. In cold weather it is well to place the acidulated water with the tissue in a glass chamber kept at 20—30° C.

The following methods are advantageous in particular cases.

- a. Place the piece of tissue, which should be small, in rather strong formic acid (1 vol. formic acid 1.16 Sp. Gr. and 3 or 4 vols. water) for a few minutes until it is fairly transparent throughout, then place it for about 20 minutes in 1 p. c. gold chloride, wash it well with water; then place it in formic acid diluted with three vols. water and leave it in the dark for a day. The formic acid should be renewed once or twice in the first two or three hours. After the tissue has been placed in gold chloride it should be exposed to light as little as possible. When the tissue is stained it should be well washed with water and mounted in formic glycerine. (Löwit.)

- b. Filter fresh lemon-juice through flannel and place the tissue in the filtrate for about 5 minutes before placing it in gold chloride. After treatment with gold chloride, wash the tissue well with water and expose to light in the ordinary way in acidulated water, or place in formic acid in the dark as in (a). (Ranvier.)
- c. The tissue after treatment with gold chloride is washed and placed in distilled water for 6 to 20 hours until it is of a steel-grey colour; it is removed to a saturated solution of tartaric acid for about 10 minutes and then warmed in the solution up to  $40^{\circ}$ — $50^{\circ}$  C. until it becomes dark; this generally takes about ten minutes (Klein). If it is desired to stain the tissue more quickly, it may be left in the gold chloride solution for about three-quarters of an hour, then well washed and at once treated with tartaric acid as above.

## Silver Nitrate.

For the method of using this cp. Less. XII. A, § 2, C, § 4, and Less. XVIII. C, § 1. It serves mainly to trace out flat tessellated epithelium, such as that of arteries, veins, or lymphatics. By exposure to light, the silver is reduced; in a fresh tissue that has been placed in nitrate of silver, the reduction on exposure takes place more readily in the homogeneous substance between the cells or 'cement substance' than in the cells.

As a consequence, where there is a single layer of cells, with a small amount of cement between them, the reduced silver in this substance marks very distinctly the outline of the cells.

The success of silver preparations largely depends upon not dragging the tissue, on washing it well, and on exposing it to a bright light. The reduction of the silver may be hastened by placing it in dilute alcohol instead of in water.

The reduction of silver goes on though slowly in the other parts of the tissue, so that it becomes darker and darker, until it is useless; this is rendered less rapid by mounting.

### MOUNTING.

The fluids in which tissues are mounted serve to make them more transparent and to preserve them.

### Glycerine.

It is best to allow sections to soak in glycerine for 5—10 minutes before mounting so that the glycerine may thoroughly penetrate them.

Some unstained tissues are made too transparent by strong glycerine, these should be mounted in glycerine diluted with one or two vols. of water.

Many gold chloride and most carmine-stained specimens are best mounted in glycerine containing 1 p. c. of formic acid 1·16 Sp. Gr. (formic glycerine).

Some hardened tissues, stained or unstained, may with advantage be kept in glycerine instead of in alcohol; before sections are made the glycerine must be extracted from the tissue with water or alcohol.

### Creosote and Turpentine.

Add 1 part of creosote to 4 of turpentine, shake well

and set aside until the cloudiness which forms on mixing the fluids disappears.

Sections may be transferred to this from strong spirit, they may however have to be gently warmed to render them clear throughout. Before mounting in Canada balsam, the sections should be examined under a low power in creosote and turpentine to see that the clearing process is complete; if they are not, fresh creosote and turpentine should be added and the sections warmed in it. Cp. also p. 75, footnote.

Before mounting the sections in Canada balsam as much of the clearing fluid as possible should be removed by means of a piece of blotting-paper with a clean cut edge.

### **Canada Balsam.**

Put some Canada balsam into a capsule, and place it in the warm chamber at about 65° C. for twenty-four hours to drive off all water. Let it cool and dissolve it in a sufficient quantity of chloroform or benzole to make a fairly fluid solution; it should be kept in a bottle with a ground glass cap fitting over the neck of the bottle, instead of a stopper, as the stopper is apt to become fixed in the bottle; if any balsam is allowed to get on the neck of the bottle wet it with spirit and rub it off with a cloth. Dammar may be used instead of Canada balsam.

Canada balsam renders tissues much more transparent than glycerine.

Tissues stained in carmine or any watery solution should be placed in alcohol of increasing strengths

up to 95 p.c. or absolute and then cleared previously to being mounted in Canada balsam.

### Injection mass.

*a.* Make a 2 p.c. aqueous solution of Berlin blue (this may be bought at a chemist's); it may be injected either cold or warm. The tissues after injection should be placed in alcohol. The sections should be cleared, and mounted in Canada balsam; if the blue has become a lighter colour during the stay of the tissue in alcohol, the sections should be placed for a day in turpentine in an uncovered watch-glass or bell-jar. Injections made with this solution are rarely so good as those made with the following (b) (c).

*b.* Place 20 grms. of gelatine in cold water until it is well swollen, then pour off the water, and place the gelatine in a water-bath at about 40° C. (covering it up to prevent evaporation) until it forms a fluid mass.

Rub 8 grms. of carmine into a paste with water, add about 10 grms. of strong ammonia and mix well, then add about 100 c.c. of water, shake well and filter; if a suction-pump is not used it will probably take 10 to 20 hours to filter. Warm the filtrate to about 40° C. Pour it then slowly into the gelatine kept warm over a water-bath, stirring continuously; when the fluids are well mixed, add gradually strong acetic acid, stirring as before; when the smell of ammonia becomes faint, use acetic acid diluted 5 to 10 times, adding it until the mixture smells of acetic acid. The mixture previously a lake red

(carmine dissolved) will become an opaque carmine red (carmine in suspension). Add a few drops of thymol, remove from the water-bath and let cool; if it does not smell of acetic acid when again melted, a little more of the acid should be added.

The gelatine mixtures must of course be injected warm; the blood should be washed out of the organ to be injected with warm salt solution; during the injection warm salt solution should be poured over the organ or the whole animal should be immersed in warm salt solution. The injected tissue should be placed in alcohol.

- c. Prepare gelatine as in (b). Take 100 c.c. of a 2 p.c. solution of Berlin blue warmed to 40°C. and pour it slowly into the gelatine kept warm on a water-bath, stirring continuously.

## CHEMICAL REAGENTS.

### Millon's reagent.

Weigh out 50 grms. of purified mercury and an equal weight of pure strong nitric acid. Place the mercury in a flask in the closed chamber, add the nitric acid to it, and leave the mixture as long as any chemical action continues. If all the mercury is not dissolved warm it *gently* to complete the solution.

Add then to it twice its volume of water, and place aside for some hours; a white crystalline precipitate will fall; the supernatant fluid is Millon's reagent.

### Fehling's fluid.

- (1) Dissolve 103.92 grams of *pure* cupric sulphate in warm water and add water to make up exactly a litre.

- (2) Dissolve 320 grams of the double tartrate of sodium and potassium in warm water, add a little carbolic acid to prevent the growth of fungi, fill up with water to exactly a litre and filter.
- (3) Dissolve 150 grams of caustic sodium hydrate in water dilute to a litre with water. If the fluid is cloudy, filter through asbestos, or let stand and decant the clear fluid.

From the above, Fehling's fluid should be made at the time it is required for use. It will not keep. To make it, equal quantities of (1), (2) and (3) are mixed together. The cupric sulphate should be shaken up and a given quantity, say 100 c.c., accurately measured, to this, 100 c.c. of (2) is added, and then (3) to make up the volume to exactly 300 c.c. From 10 c.c. of this mixture, the cupric salt is reduced by .05 gram of dextrose.

### Stokes' fluid.

This should be made afresh when required; it consists of a solution of ferrous sulphate, to which ammonia has been added after the previous addition of sufficient tartaric acid to prevent precipitation. An excess of tartaric acid is not of consequence; roughly speaking, three parts by weight may be added to two parts of ferrous sulphate.

### MAJOR ARTERIAL SCHEME.

This (see Fig. 8) is a modification of Weber's original scheme of the circulation. It is not intended to imitate the details of the circulation of the blood, but simply to illustrate the points to which attention is called in Lesson XIII. It can without much



difficulty be made by joining together india-rubber tubing by means of three-way glass tubes.

Clamps are placed upon the straight tubes  $c$ ,  $c'$ ,  $c''$ , and the dilated tubes along the same line are stuffed with sponge, until on closing the clamps and pumping steadily, a mean pressure of two or three inches of mercury is obtained in the arterial tube.

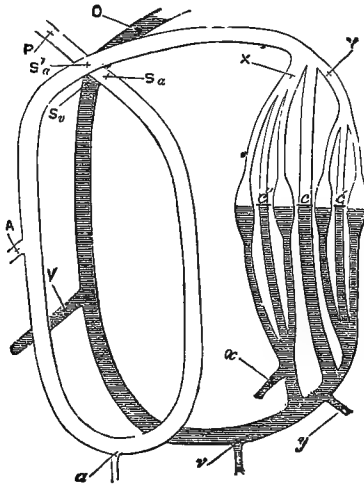

FIG. 8.

The arterial tube  $P$  is connected with an india-rubber bag; from the opposite end of which a tube passes to a vessel full of water. The bag has two valves, one at each end, opening in the same direction, so that when it is compressed with the hand the water it contains is driven onwards through the arterial tube, and on its dilating water is drawn up from the vessel.

Any other form of pump can be used.

At  $S_a$ ,  $S'_a$ ,  $S'_v$  are placed vertically above one another either the usual sphygmograph levers or light levers such as are used to take tracings of the movements of the frog's heart (cp. p. 349). The tubing can be supported on pieces of lead bent to fit its course and fastened to a stand. Each of the tubes  $A$  and  $V$  communicates with a mercurial manometer.

The rest of the scheme requires no explanation further than that which is given in the text.

#### MINOR ARTERIAL SCHEME.

This consists of an india-rubber bag like that used in the major arterial scheme. By means of a three-way tube, the end of this, towards which the valves open, is connected both with a piece of glass tubing about a yard and a half in length, and with a piece of india-rubber tubing of similar length and bore.

There are clamps upon the long india-rubber tube close to its junction with the three-way tube and upon the small piece of india-rubber which connects the three-way tube with the glass tube, so that the flow of water may be through either the glass or the india-rubber tube.

A small piece of india-rubber tubing is also placed on the end of the glass tube, into which a tube finely drawn out can be inserted.

#### TO DESTROY THE BRAIN OF A FROG.

Place the frog under a small bell-jar with a sponge moistened with ether; when the animal is motion-

less and under the influence of the anæsthetic, take it up in a cloth, hold the hind legs between the third and fourth fingers, and with the fore-finger press down the head. Cut transversely through the skin a little behind the skull with a pair of scissors, carrying the incision only a short way on either side of the median line; make a slight incision also through the skin in the median line. The end of the occipital bone can then be easily made out; it is just above the level of the anterior edges of the scapulæ. With a sharp scalpel cut through the muscles just behind the occipital bone and as nearly as possible in the median line, so as not to cut the vertebral arteries; the spinal cord will be exposed. Thrust then a blunt stout needle into the brain and move it about until the brain is quite destroyed.

The following rough table may be useful to the student.

1 litre	= 1 cubic decimetre = $1\frac{1}{8}$ pints nearly.
1 minim	= .059 cubic centimetres.
1 pint	= 0.57 litres.
1 gallon	= 4.54 litres.
1 fluid ounce	= $\frac{1}{8}$ pint.
1 sq. inch	= 6.45 sq. centimetres.
1 cubic inch	= 16.39 cubic centimetres.
1 gram	= 15.43 grains.
1 kilogram	= 35.27 oz. Avoird. = 2.2 lbs
1 grain	= 0.065 gram.
1 drachm	= 3.88 gram.
1 oz. Troy	= 31.1 gram.
1 oz. Avoird.	= 28.35 gram.
1 lb. Avoird.	= 0.45 kilogram.
1 centimetre	= $\frac{2}{5}$ inch.
1 metre	= 1 yard $3\frac{1}{8}$ inches.
1 inch	= 2.54 centimetres.
1 foot	= 3.05 decimetres.
1 yard	= 0.91 metre.
$\frac{1}{1000}$ inch	= $\frac{1}{25}$ millimetre about.
$\frac{1}{2000}$ inch	= 12.7 $\mu$ .
$\frac{1}{2500}$ inch	= 10.16 $\mu$ .

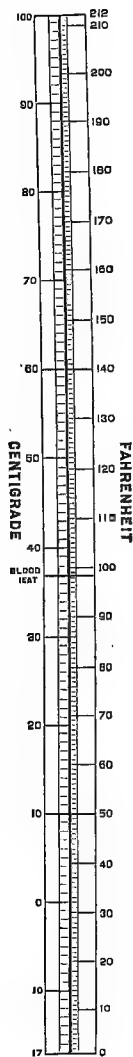
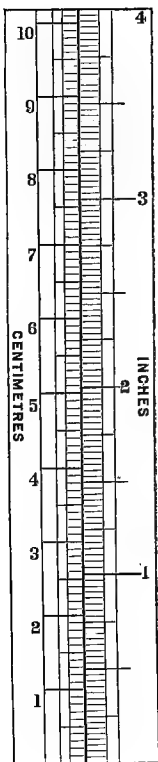

## ADDITIONS.

**Platelets of Blood. (Blutplättchen.)** The platelets are colourless bodies about  $\frac{1}{3}$  the size of the red corpuscles; in shape fairly like the red corpuscles, and nucleated when the red corpuscles are nucleated. They very readily break down into formless granular masses. In the frog or newt they are readily seen in the capillary circulation of the mesentery or other part of the animal. During inflammation (cp. p. 133) they will be seen clinging in numbers to the inner walls of the small vessels. They may also be seen in a drop of blood if it is examined *immediately* after being drawn from the body; certain fluids retard the rate of disintegration of these corpuscles, the corpuscles are longer preserved if a little blood be allowed to run from the body into 3 to 5 times its volume of one of the following: sodium chloride .6 p.c. with a little methyl-violet (about 3 c.c. sodium chloride solution and one drop of a strong aqueous solution of methyl-violet); 20 p.c. magnesium sulphate; 1 p.c. osmic acid.

### HARDENING AGENTS.

**Mercuric chloride.** A saturated aqueous solution is a good general hardening agent for glands and epithelium of skin and cornea. The tissue is left in the mercuric chloride solution for several days,

placed in a stream of water for some hours to remove the mercuric salt, and further hardened in alcohol. As the mercuric salt is soluble in alcohol, the tissue may be removed from mercuric chloride to alcohol. In this case, however, the alcohol should be renewed several times.

**Flemming's mixture** is used chiefly to harden tissues in which it is desired to make dividing nuclei obvious, and consists of

Chromic acid 1 p.c.—15 parts.

Osmic acid 2 p.c. —4 parts.

Glacial acetic acid — $\frac{1}{2}$  to 1 part.

In this the tissue should be left two or three days, washed with water, and treated in the usual way with alcohol.

#### IMBEDDING, SECTION CUTTING, MOUNTING.

When a number of sections have to be prepared for distribution amongst students, the freezing method given in the Appendix is only satisfactory with tissues that are firm and hold well together. Other tissues should be either imbedded in celloidin, or imbedded in hard paraffin with a view to preparing ribbons of sections.

#### **Paraffin. Ribbons of Sections.**

*Imbedding and cutting.* The piece of hardened and stained tissue is placed in absolute alcohol for 1 to 24 hours. From this it is removed to either chloroform, turpentine, or oil of cloves. It is then placed in hard paraffin (melting-point about 58° C.), kept at a constant temperature, not greater than 60° C., for two or more hours, and imbedded in the manner

given on p. 366, § 4. The paraffin is sliced away until the surface is very nearly reached, then the paraffin at the sides of the tissues is sliced away in such a manner that the surface to be cut is rectangular. The shaped end of the paraffin block is dipped for a moment in melted soft paraffin, i.e. paraffin melting at about 40° C. The block is fixed in a microtome, and arranged so that the edge which meets the razor is parallel to the edge of the razor, the soft paraffin may be cut away from the two sides of the block which are at right angles to the razor edge. The soft paraffin causes each section as it is cut to stick to the preceding one, and thus a ribbon of sections is obtained. Of the less expensive forms of microtome adapted for cutting ribbons of sections the most convenient is the Rocking Microtome of the Cambridge Scientific Instrument Company. In this a short tube is filled with hard paraffin, and the base of the block of paraffin containing the tissue to be cut is sliced away within a few millimetres of the tissue, this is held down on the paraffin mass of the microtome tube and a hot knife passed between the two surfaces and around the junction of the block with the paraffin mass. Thus the tissue to be cut is firmly fixed when the paraffin solidifies. It is best to do this before coating with soft paraffin.

*Mounting.* Take a thin solution of white shellac in kreosote and paint a thin film of it over a clean dry glass slide. On this place the section or sections it is desired to mount, press each gently with a camel hair brush to make it lie flat. Place the slide in a warm chamber until the paraffin is melted;

remove then the slide to bottle of turpentine for a few minutes until the paraffin is dissolved. Let the turpentine drain from the slide. Place a streak of rather thin balsam (dissolved in a mixture of chloroform and benzol) near one edge of the cover-slip, and lower this gently on the sections. By this method the tissue sticks to the shellac and the parts of the section are not displaced on dissolving out the paraffin.

Instead of the shellac solution, equal parts of filtered white of egg and glycerine to which a little thymol has been added, may be used. The treatment is the same as that given above, except that after the paraffin has been dissolved by turpentine, the slide should be placed for a minute or so in absolute alcohol. If required the sections can then be stained on the slide.

### **Celloidin.**

Imbedding in celloidin has the advantage that it is not necessary to warm the tissue, and thus there is little risk of the tissue shrinking. By the simple celloidin method, however, such thin sections cannot be obtained as by the paraffin method. But when the tissue imbedded in celloidin is soaked in gum, frozen and cut, this objection to the method no longer holds.

*Celloidin solution.* The celloidin solution is cut up into small pieces and dissolved in a mixture of equal parts of absolute alcohol and ether to make a fairly fluid solution. It is sometimes advisable to use a thicker solution after this.

*Treatment of tissue.* (a) The tissue, dehydrated with absolute alcohol—after which it may be placed in a mixture of absolute alcohol and ether or in ether alone—is placed in celloidin solution and left in it



for one day to a week or more. (b) Whilst the tissue is in absolute alcohol  $\frac{1}{4}$  vol. ether is added, and then celloidin in small fragments from day to day, so that solution slowly goes on and a fairly thick solution is obtained in 8 to 10 days.

*Celloidin hardened in 80 p.c. alcohol.* The tissue is removed from the celloidin solution, placed on a cork and a little of the solution poured over it; when a thin film has formed on the surface of the celloidin the whole is put in alcohol 80 p. c. In a day or more the tissue can be cut. During cutting, the razor should be kept wet with 70 to 80 p. c. alcohol. Instead of fixing the tissue to cork it may be placed in a small paper case, celloidin poured over it and treated as above. When the outer part is firm the paper should be removed.

*Celloidin hardened in chloroform.* Chloroform is used instead of the 80 p.c. alcohol of the previous section; or a little celloidin solution is gently poured on chloroform, when the lower surface is firm the tissue is placed on the celloidin and more of the solution poured over it. The celloidin shrinks much less and remains more transparent with chloroform than with alcohol.

*Celloidin hardened by evaporation.* The tissue is removed from celloidin solution to a small watch glass with a thin layer of celloidin over it, the small watch glass covered with a larger one for two or three hours till the celloidin is fairly firm, it is then coated with fresh celloidin, allowed to dry partially, and so on until (in 1 to 3 days) a sufficient coating of firm celloidin is obtained. Or the tissue with celloidin may be poured into a small glass dish, this covered

with a flat piece of glass, allowing of a *slow* evaporation of the alcohol and ether, so that the celloidin becomes fairly hard in two or three days.

*Preparation for freezing.* The celloidin around the specimen, imbedded in one of the above ways, is pared away and the block placed in water for an hour or two, then transferred to gum for one or two days or for any longer time. The block can then be frozen and cut. Thinner sections can thus be obtained than from celloidin alone.

*Staining sections.* The sections still permeated by celloidin may be stained with carmine or with hæmatoxylin. Most aniline dyes stain the celloidin also. If required, the celloidin may be dissolved out by absolute alcohol; or by a mixture of absolute alcohol and ether.

*Mounting.* The celloidin need not be dissolved before mounting. If sections are to be mounted in Canada balsam and other substances which render it necessary to dehydrate the tissue, this should be done with 90 to 95 p.c. alcohol and origanum or bergamot oil, instead of with absolute alcohol and clove oil, since the latter dissolve the celloidin. Clove oil does not however dissolve the celloidin very rapidly, so that, if the sections are large, clove oil may be used; in this case the sections should be removed and mounted as soon as they are clear.

### Mounting in glycerine-jelly.

The glycerine-jelly may be made as follows:

Glycerine 70 c.c.

Water 60 c.c.

Gelatine 10 grams.

A little thymol or camphor, or carbolic acid.

Place the gelatine with the water in a porcelain capsule, heat the mixture in a small water-bath over a Bunsen burner, until the gelatine is dissolved, stirring the while and taking care that the gelatine does not stick to the capsule. The water should not be allowed to boil, or at any rate for a short time only. To the hot solution add the glycerine and a drop or two of a strong alcoholic solution of thymol. If necessary cool the mixture to about  $40^{\circ}$  C., add the beaten up white of an egg and well mix. Then heat as before to about  $90^{\circ}$  C. stirring continuously. Filter through a hot water filter.

The gelatine may be left for a day in the cold water to swell up, then dissolved by warming to about  $40^{\circ}$  C. The glycerine, warmed to about the same temperature, is added. Then proceed as above.

To mount a section in glycerine jelly, place a small bottle containing glycerine-jelly in a warm chamber. Remove the section from water to a slide, sop up the excess of water, and let fall on it a drop of the melted glycerine-jelly. Place the slide and a cover-slip in the warm chamber for a minute or two, if the section rises to the top of the fluid press it down with a needle so that it lies on the glass. Then cover with the warm cover-slip.

If a warm chamber is not at hand melt the glycerine-jelly in the flame of a Bunsen burner, warm a slide in the flame and place a drop of the melted jelly on it. With a needle transfer a section to the jelly, and spread it out flat on the glass. Pass a cover-slip through the flame, and cover the section.

Before surrounding with Canada balsam or other cement the specimen should be examined with a

high power to see that the layer of jelly is not too thick. If it is, warm the specimen and gently press the cover-slip, let cool, scrap away the pressed out jelly, and surround the edges of the cover-slip with cement.

### **Mounting in Farrant's solution.**

Pure gum arabic 40 grams.

Water 40 c.c.

Glycerine 20 c.c.

A little thymol or other preservative.

The mixture may be made thus:—Take lumps of gum arabic which are nearly free from colour, weigh out 40 grams, grind to powder, place in about 150 c.c. water, warm or boil to dissolve. Add a few drops of a strong alcoholic solution of thymol. Filter through a hot filter, changing the filter when clogged. Evaporate the filtrate until it is about 80 c.c., then add the glycerine. The mixture is best kept in a bottle with a glass cap.

When mounting in this, let a section soak for a minute in glycerine, then in a drop of Farrant's solution on the slide. Before cementing, the solution should be allowed to become firm at the edges.

### **STAINING.**

**After treatment with osmic acid.** When it is required to harden a tissue in osmic acid and afterwards to stain it, the tissue should be left for half-an-hour to two hours only in the acid; then washed well with water and kept in alcohol for a few days.

**Nitrate of silver preparations.** The reduction of silver in these may be greatly retarded by placing them for a few minutes in a 2 to 10 p.c. solution of

sodium hyposulphite, after the required degree of reduction has taken place. The sodium hyposulphite must be thoroughly washed out with water.

### **Delafield's hæmatoxylin.**

Make (1) A saturated solution of hæmatoxylin in absolute alcohol.

(2) A saturated solution of ammonia alum in the cold.

Add 4 c.c. of (1) to 150 c.c. of (2), leave for a week, filter, to the filtrate add 25 c.c. glycerine and 25 c.c. of methyl-alcohol.

This is often called Grenacher's hæmatoxylin. It stains nuclei well and quickly. To dilute it add some of the mixture minus the hæmatoxylin.

**Staining for indirect nuclear division.** The tissue should be hardened in Flemming's mixture (cp. p. 388). The sections are placed in a strong alcoholic solution of safranin, *e.g.* a saturated solution of safranin in absolute alcohol diluted with an equal quantity of water, and left for a day. They are treated with dilute alcohol and then placed in absolute alcohol containing .3 to .5 p.c. hydrochloric acid. In this fluid they are left until colour ceases or nearly ceases to be extracted from them. It is best to examine a section from time to time, when in such a section the cell-substance is decolourized the remaining sections should be removed (twice) to absolute alcohol free from acid. They are then placed in clove oil, and as soon as they become transparent mounted in Canada balsam. Sections may also be stained with Delafield's hæmatoxylin.

To observe the typical changes in indirect nuclear division, a larval salamander 2 to 3 c.m. long, hardened in Flemming's mixture, may be conveniently taken, divided into two or three pieces, and then cut longitudinally.

### Staining medullated fibres in grey substance. Weigert's method.

Prepare

- (1) *Mordant solution.* An aqueous solution of normal cupric acetate saturated in the cold, and add an equal volume of water.
- (2) *Staining solution.* Dissolve 1 gram of hæmatoxylin in 10 c.c. of absolute alcohol, add 90 c.c. of water and 1 c.c. of a cold saturated aqueous solution of lithium carbonate (or sodium carbonate).
- (3) *Decolourizing solution.* Dissolve  $2\frac{1}{2}$  grams of potassium ferricyanide and 2 grams of borax in 200 c.c. of water.

Sections are placed in the cupric acetate in the warm for a day, washed in water, and transferred to hæmatoxylin for two hours to a day. The sections, now quite black, are washed with water and placed in the potassium ferricyanide solution for a few minutes to two hours, until the grey substance becomes of a light tint; if the decolourization is rapid, it is better to dilute with water the ferricyanide solution; the sections are then well washed with water, treated with alcohol, and mounted in Canada balsam.

Another method of decolourizing is given by Pal; the sections after having been stained, are washed with water containing a little lithium carbonate, placed in .25 p. c. potassium per-

manganate for 15 to 20 secs., washed with water, placed for a few seconds to a few minutes in a mixture of

- 1 gram pure oxalic acid
- 1 gram potassium sulphite
- 200 c.c. water,

and again washed well with water. The parts of the tissue other than medullated fibres are thus more completely decolorized than by Weigert's method. The sections may finally be stained with alum-carmin.

### Solutions for Liebig's method of estimating urea.

(a) *Standard mercuric nitrate solution.* Take 71.48 grams of pure mercury, add 5 vols. nitric acid Sp. Gr. 1.425, and warm on water-bath until the mercury is completely dissolved; evaporate the solution to a syrupy consistence, until the addition of a few drops of nitric no longer causes red nitrous fumes to come off, evaporate further until the fluid acquires a faint yellowish tinge. Stir and add about 10 vols. of water; if a precipitate is formed let stand, pour the clear fluid into a litre flask, to the residue add the minimal quantity of strong nitric acid necessary to dissolve the precipitate, add this to the fluid in the flask, wash the vessel out with water, add this to the previous fluid and fill up to exactly a litre.

One c. c. of this solution precipitates 10 mgs. of urea and leaves just enough mercuric nitrate over to be detected by sodium carbonate.

The method given above can only be used when the mercury is pure, if there is any doubt about this, the mercuric nitrate solution diluted to somewhat less than a litre should be titrated with a solution of pure urea and then further diluted to the proper amount.

(b) *Baryta mixture.* Add two volumes of barium nitrate, saturated in the cold, to one volume of barium hydrate, also saturated in the cold,

**A standard urea solution** for titrating the mercuric nitrate solution may be made by drying urea over sulphuric acid, weighing out 4 grams and adding water to make up 200 c.c. 10 c.c. of this just give the end-reaction with 20 c.c. of standard mercuric nitrate solution. This however is only the case when the mercuric nitrate solution is neutralized by sodium carbonate immediately after being added to the urea solution. As this point is neglected in the method given in the text, it may be neglected in preparing the standard solution.

### **Liebig's method.**

Take 40 c.c. of urine and add 20 c.c. of the baryta mixture a copious precipitate of barium phosphate, sulphate, carbonate will be formed. Shake to mix well the fluids and filter through a dry filter. The object of this is to remove the phosphates, these give a precipitate with mercuric nitrate.

Fill a burette with the standard solution of mercuric nitrate. On a glass plate lying on a dull black surface, place a number of drops of a saturated solution of normal sodium carbonate.

*Preliminary estimation.* In a beaker place exactly 15 c.c. of the filtered urine-mixture, into this run slowly the mercuric nitrate solution from the burette. Stir with a glass rod, and from time to time, add a drop of the mixture to one of the drops of sodium carbonate; as soon as a yellow colour is thus produced, note the amount of mercuric nitrate which has been added. The yellow colour is produced when all the urea has been precipitated and there is an excess of mercuric nitrate; this with sodium carbonate gives a



yellow precipitate of oxide of mercury or of a basic mercuric carbonate.

*Second estimation.* In the preliminary estimation too much mercuric nitrate will probably have been added; so the process should be repeated, adding at once the amount of mercuric solution found in the preliminary estimation less 1 c.c. After well mixing, a drop is added to a drop of sodium carbonate; if a yellow colour results, the process must be repeated adding less mercuric nitrate; probably however the mixed drops will be colourless, if so add .1 c.c. mercuric nitrate, mix and test again, and so on adding .1 c.c. at a time until a yellow colour is obtained.

*Correction.* Since the sodium chloride in the urine prevents the precipitation of urea by mercuric nitrate (cf. § 5 e) more mercuric nitrate is added to the urine than is required to precipitate the urea in it. The excess thus added is found experimentally to be about 2 c.c. for 10 c.c. of urine. *Hence 2 c.c. must be deducted from the number of c.c. of the standard solution actually used.*

If  $v$  be the corrected number of c.c. of mercuric nitrate used, the 10 c.c. of urine taken, contain  $.01v$  grams of urea, i.e. the percentage of urea in the urine is the  $0\cdot v$ .

*Note.* The method as above given is very rough. For an accurate estimation, the sodium chloride as well as the phosphates must be separated from the urine, the filtered mixture must be neutralized, and again neutralized with sodium carbonate after each addition of mercuric nitrate. It must also be remembered that the amount of urea found by this method is too high,

since ammoniacal salts, and all the nitrogenous bodies in the urine give a precipitate with mercuric nitrate.

**Hypobromite method of estimating urea.** (Cf. p. 242).

*Hypobromite solution.* Dissolve 100 grams of sodium hydrate in 250 c.c. water, cool, and add gradually 25 c.c. of bromine, cooling the mixture in a stream of water as the bromine is added. The

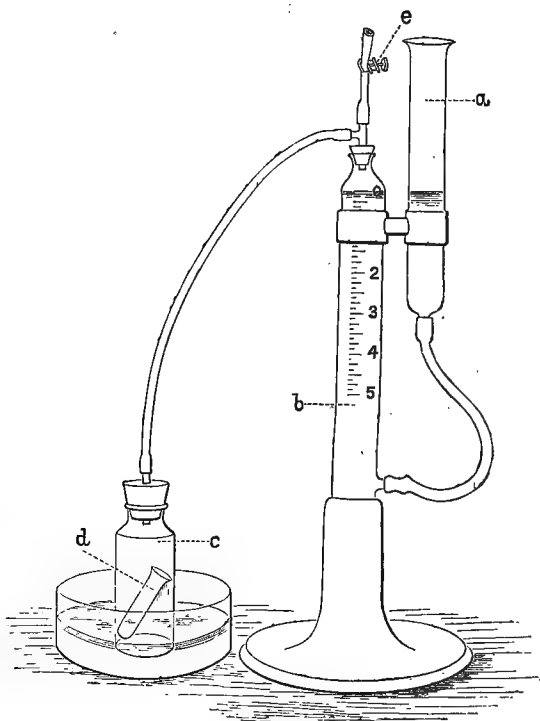

sodium hydrate solution should be kept ready, and bromine added just before the mixture is required. It is convenient to have thin glass capsules, each containing 2·3 c.c. of bromine, if one of these be placed in 25 c.c. of the hypobromite mixture broken by a sharp shake, the proper amount of hypobromite solution for a single observation is obtained.

*Method of using Gerrard's apparatus.* In this, as in many other forms of apparatus, the collecting tube is graduated so as to show percentages of urea when 5 c.c. of a urea solution are taken.

Raise the tube (*a*) to about the height shown in the figure, pour water into it until the tube (*b*) is filled with water to the zero mark. Pour 25 c.c. of hypobromite solution into the bottle (*c*), measure from a burette 5 c.c. of urine into the tube (*d*). With the aid of a forceps, place the tube (*d*) in the bottle, being careful not to spill any of the urine. Fit the cork, with the tube attached to it, tightly into the bottle, and clamp the tube (*e*). Fill up and gently shake the bottle so that the urine and the hypobromite solution mix. Place the bottle in a basin of water. Lower (*a*) until the level of the water in it is the same as that in (*b*). Leave for about five minutes, re-adjust the level of the water in the two tubes, and note how much nitrogen has been given off.

An estimation of urea should also be made, using two burettes instead of the tubes (*a*) and (*b*). The volume of nitrogen evolved is measured in

cubic centimetres, and from this the percentage of urea is calculated in the manner given below.

*Deficit of Nitrogen.* The chief causes of variation in the amount of nitrogen given off, have been mentioned in the text. Hüfner, Pflüger and Schenk find with the apparatus used by them, and with a 1 p.c. solution of urea, that the deficit of nitrogen is very nearly 4.4 p.c., i.e. 1 gram of urea instead of giving off 373 vols. of nitrogen gives off 357.

Russell and West using a 2 p.c. solution of urea find with their apparatus a deficit of nearly 8 p.c., i.e. 1 gram of urea, instead of giving off 373 vols. of nitrogen gives off about 343 vols. When the volume of the gas is measured at a temperature of 18° C., no correction being made for the tension of the aqueous vapour, the deficit of 8 p.c. is nearly corrected by the expansion of the gas, so that according to Russell and West, in making an approximate estimate of urea with their apparatus, no account need be taken of a deficit of nitrogen, nor any correction be made for temperature and pressure.

*Correction for temperature and pressure.* If  $v'$  be the volume in cubic centimetres of the nitrogen obtained, at temperature  $t^\circ$  C. and pressure  $B$  in mm. of mercury, and  $T$  be the tension of aqueous vapour at  $t^\circ$  C., the volume  $v$  at  $0^\circ$  C. and 760 mm. pressure will be

$$\frac{v'}{1 + .003665 t} \times \frac{B - T}{760},$$

.003665 being the coefficient of expansion of gases.

*Calculation of percentage of urea.* Theoretically 373 c.c. of nitrogen are given off by 1 gram of urea, if then  $v$  c.c. of nitrogen, after correction for temperature and pressure, are obtained in an experiment, this will have been given off by  $\frac{v}{373}$  grams of urea, that is there are  $\frac{v}{373}$  grams of urea in the 5 c.c. of urea solution taken, so that the percentage of urea in the solution is  $\frac{20 v}{373}$ .

But since in practice the whole of the nitrogen is not given off, the deficit must be allowed for, if we take Hüfner's estimate of the deficit of the volume of the nitrogen, viz. 4.4 p.c., the percentage will be  $\frac{20 v}{357}$ .

*Sources of error in estimating urea in urine.* Nitrogenous bodies other than urea are partially decomposed. Further certain substances increase and others decrease the completeness of the decomposition.

# INDEX.

## A.

Abdominal aorta, 23  
Abdominal muscles, of dog and rabbit, 1  
Absorption of fat in small intestine, 183  
Accommodation of the eye, 275  
Acetic acid, effect on blood corpuscles, 38, 39, 42; effect on cartilage cells, 53; on elastic fibres, 58; on white fibrous tissue, 59, 62; on striated muscle, 83  
Acid-albumin, 45, 101, 102, 173  
Adenoid tissue, 179, 191  
After-image, positive, 285; negative, 286, 287  
Albumin, 51; in milk, 175; in urine, 241  
Alcohol, for dissociating tissues, 358; for hardening tissues, 364  
Alkali-albuminate, 102, 103  
Alkalinity of blood, 45  
Alum-logwood, 372  
Ampulla, 291  
Anterior nares, 30  
Aorta, in heart of sheep, 136, 137  
Appendix of large intestine of rabbit, 3  
Aqueous humour, 264  
Arterial scheme, minor, 147; major, 148  
Arteries, caeliac, 4; superior mesenteric, 4; renal, 4; splenic, 6; hepatic, 6, 7; lieno-gastric, 6; pancreatic, 6; common carotid, 18, 20; innominate, 20, 137; pulmonary, 21; femoral, 23, 91; coronary, 140;

interlobular, 234; vertebral, 313; basilar, 313; internal carotid, 313; posterior cerebral, 313; middle cerebral, 313; anterior cerebral, 314; structure of, 124  
Artery, epithelium of, 126  
Arytenoid cartilage, histology, 70; dissection, 333  
Arytenoid muscle, 333  
Astigmatism, 279  
Auricular nerve of rabbit, 25  
Automatic action, 120  
Axial zone of blood current, 131  
Axis band, of malleus, 296  
Axis-cylinder, 106  
Azygos vein, in heart of sheep, 138

## B.

Basilar membrane, 299; artery, 313  
Bidder's ganglia, 145  
Bile, reaction of, 184; effect on gastric digestion, 187; capillaries, 204; ducts, 206; -pigment, 241; -acids, 242  
Bile-salts, preparation of, 185  
Biuret reaction, 239  
Bladder, 10; structure of, 235  
Blind spot, 281  
Blood pressure, 147  
Blood, structure of, 35 ff; of frog or newt, 35; of man, 41; coagulation of, 44 ff; circulation of, 131, 134; colour of, 219  
Bone, 30; structure of, 72; extraction of salts from, 359, 361  
Boracic acid, effect on red corpuscles, 40

- Brain, of dog or sheep, dissection, 308; method of hardening, 308, 327; parts seen in sections, 321
- Brunner, glands of, 181
- Bulb, olfactory, 323
- Bulbus arteriosus, in heart of frog, 141, 142
- C.
- Caecum, 2
- Celiac artery, 4
- Calamus scriptorius, 313
- Calices, of kidney, 228
- Camera lucida, 352
- Canada balsam, 379
- Canaliculi, 73
- Capillaries, structure of, 127
- Cardiac muscle, 88
- Carmine, 373; picro-, 374; borax-, 374
- Carotid artery, common, 18, 20; internal, 313
- Cartilage, hyaline, 52; costal, 33, 54, 55; of cuttle fish, 56; parenchymatous, 56, 57; intervertebral, 68; fibro-, 70; elastic, 71; arytenoid, of sheep, 70
- Casein, in milk, 175, 176
- Cedar wood oil, 375
- Central canal, 302
- Cerebellum, of dog or sheep, 308; inferior peduncles of, 310; superior peduncles of, 310; middle peduncle of, 311; structure of, 329
- Cerebral arteries, posterior, 313; middle, 313; commissures, 320, 321; anterior and posterior, 321
- Cerebral hemispheres, of rabbit, 11; of dog, 12
- Cerebrum, of dog or sheep, 308
- Cervical ganglion, inferior, 20; superior, 28
- Chemical stimulation of muscle, 93
- Cholesterin, 187
- Chorda tympani fibres, 26, 27
- Chordae tendineae, 139
- Choroid, 264; pigment of, 273; plexus, 309, 316, 319
- Chromic acid, staining after, 69; for hardening, 361
- Ciliary action, 81, 122; muscle, 264, 267; processes, 265
- Ciliated cells, of frog, 80
- Circulation of blood (frog) in web, 131; in tongue, 134; in mesentery, 135
- Clarke, column of, 305
- Cochlea, promontory of, 295; structure of, 299, 300
- Commissure, of spinal cord, 303; of brain, 320, 321
- Common iliac, 23
- Condylod foramen, 29
- Conjunctiva, 263
- Connective tissue, 58; sub-cutaneous, 247
- Constant current, effect on nerve, 90, 91
- Contrast, simultaneous, 287
- Convolutions, of dog, supra-callosal, 324; internal, 324; Sylvian, 324; inferior, 324; median, 325; superior, 325
- Cornea, of frog, 61, 109, 250, 268; of cat, 251, 263, 264
- Cornu, anterior and posterior, 302
- Corona radiata, 323
- Coronary vein, in heart of sheep, 138
- Corpora, quadrigemina, 310; lutea, 337
- Corpus, Arantii, 139; albicans, 311; callosum, 315, 322; geniculatum, 320; Highmori, 341
- Corpuscles, in blood of frog, 36, 38, 39, 133; in blood of man, 41, 42; connective-tissue, 60; bone, 74; Malpighian, 195, 197; touch-, 252
- Corpus dentatum, of cerebellum, 312
- Cortex of cerebrum, structure of, 327
- Corti, rods of, 300
- Cover cells, 260
- Cranial nerves, 11; superficial origin, 314

Creosote, 378  
 Crico-arytenoids, posterior and lateral, 331  
 Cricoid cartilage, 332  
 Crico-thyroid muscle, 332  
 Crista acustica, 292  
 Crucial fissure, 325  
 Crura cerebri, 311  
 Crural vein, 23  
 Crusta of brain, 322  
 Crusta petrosa, 77, 78  
 Cumulus proligerus, 338

## D.

Decussating fibres of bone, 75  
 Decussation of the anterior pyramids, 326  
 Demilune cells, 156  
 Dental nerve, inferior, 23  
 Dentate fissure, 319  
 Dentine, 77, 78  
 Depressor nerve, 19, 21  
 Dermis, 247  
 Descemet, membrane of, 209  
 Dextrin, 162  
 Dextrose, 162  
 Diaphragm, of dog and rabbit, 7, 11; structure of, 201, 202  
 Diffusion circles, 276  
 Digastric muscle, 26, 27  
 Dissection, of rabbit and dog, 1  
 Dissociating fluids, 358  
 Dorsal aorta, 4  
 Dorso-lumbar fascia, 2  
 Duodenum, 3, 4, 9  
 Dura mater, of dog, 11, 129, 303  
 Diallyser, 165

## E.

Elasticity of red corpuscles, 40  
 Electrodes, non-polarizable, 348  
 Enamel of teeth, 77, 78  
 Epidermis, 246  
 Epididymis, 10, 341  
 Epiglottis, 30  
 Epithelial nerve plexus, 251  
 Erlicki's fluid, 361  
 Eustachian tube, 31, 298

Eustachian valve, in heart of sheep, 138  
 Eye of sheep, dissection of, 263; retina of, 264

## F.

Facial nerve, 24  
 Fallopian tube, 10  
 Falx cerebri, 11  
 Fasciculus, of Goll, 305; cuneatus, 305, 309; gracilis, 309  
 Fat-cells, 65  
 Fat-ferment of pancreatic juice, 190  
 Fehling's fluid, 381  
 Femoral artery, 23, 91  
 Fenestra ovalis, 298  
 Fenestrated membrane of arteries, 126  
 Fibres, elastic, 58, 214; white, 58; perforating, 74; of Muller, 272  
 Fibrin ferment, 49  
 Fibrin, 44; for digestion experiments, 172  
 Fibrin fibrils, under microscope, 41  
 Fibrinogen, 48  
 Fimbria, 316  
 Fissures of spinal cord, anterior and posterior, 302; (of brain of dog,) crucial, 325; Sylvian, 324; dental or hippocampal, 319  
 Foramen, jugulare, 19, 29; condyloid, 29; rotundum, 295; of Monro, 318  
 Fornix, 316; anterior and posterior pillars of, 317  
 Fossa ovalis, in heart of sheep, 138  
 Freezing microtome, 369  
 Fresh tissues, methods of observing, 355

## G.

Gall-bladder, 7  
 Ganglion, spinal, 14, inferior cervical, 20; first thoracic, 20; of the vagus, 28; superior



- cervical, 23; Gasserian, 32, 112; cells, 111  
 Gasserian ganglion, 32, 112  
 Gastric juice, artificial, 171; action of, 172, 173; action of, on milk, 176  
 Gastric veins, 6  
 Germinal epithelium, 336; vesicles, 337; spot, 337  
 Gland, thyroid, 23; parotid, 24; submaxillary, 26; Harderian, 31; orbital, 31; lachrymal, 31; intestinal, 179; of Lieberkühn, 179; of Brunner, 181; serous and mucous, 214; sebaceous, 249; pineal, 320  
 Globulin, 51, 101  
 Glomeruli, 231  
 Glosso-pharyngeal nerve, 29, 141  
 Glycerine, 378  
 Glycogen, 205, 208  
 Gmelin's test, for bile pigments, 185, 241  
 Gold chloride, to stain cartilage, 53; to stain cornea, 61; subcutaneous connective tissue, 63; septum auricularum, frog, 144; lung of newt, 211, 376  
 Goll, fasciculus of, 305  
 Graafian follicles, 336, 337  
 Gum arabic for imbedding, 369
- H.
- Haematoxylin, to stain cartilage, 56; Kleinenberg's, 371; alum, 372  
 Haemin, crystals of, 226  
 Haemoglobin, 40; to prepare, 220, 221; crystals of, 221; reduced, 224  
 Hair-follicles, 248; -cells of organ of Corti, 299, 300  
 Hardening agents, method of using, 359; to make solutions, 360  
 Harderian gland, 31  
 Haversian canal, 72  
 Heart, of frog, 120, 140; of sheep, 136, 137  
 Helmholtz, phakoscope of, 278  
 Hepatic artery, 6, 7, 206; duct 7; veins, 8; cells, 206  
 Hippocampal fissure, 319  
 Hippocampus major, 316  
 Hyaloid membrane, 265  
 Hydrophilus, muscle of, 84  
 Hypoglossal nerve, 28, 29
- I.
- Ileum, 3  
 Imbedding, 365 ff  
 Incus, 297  
 Induction machines, 346  
 Induction shocks, effect on nerve, 92  
 Inferior cervical ganglion, dog, 23  
 Inflammation, 133  
 Infundibulum, 312  
 Inhibition of heart by vagus, 142  
 Injection mass, 380  
 Inner capsule, 323  
 Innominate artery, 20; in heart of sheep, 137  
 Innominate veins, dog, 22  
 Intermediate layer of sheep's kidney, 228, 229  
 Intermedio-lateral tract of nerve cells in spinal cord, 305  
 Internus obliquus abdominis, 2  
 Interrupted current, effect on nerve, 93  
 Intercostal muscle, external, 15; internal, 16  
 Intestinal glands, 179, 182  
 Intestine, small, of dog and rabbit, 2; large, 3, 9; method of hardening, 33; structure of, 178  
 Intralobular veinlet, 205, 206, 234  
 Iodine, 376  
 Iodized serum, 357, 358  
 Irradiation, 281  
 Iris, 270  
 Iter, 313
- J.
- Jacobson's nerve, 29  
 Jejunum, 3  
 Jugular veins, 18, 19

## K.

- Keys of du Bois-Reymond and Morse, 345  
Kidneys of dog and rabbit, 9, 10 ;  
of sheep, 228

## L.

- Lachrymal gland, 31  
Lactic acid, 176  
Laky blood, 219  
Lamina fusca, 264  
Lamina spiralis, 298  
Laryngeal branches of vagus, 18,  
20  
Larynx, dissection of, 331  
Lateral, columns of spinal cord,  
302 ; ventricle of brain, 316  
Lens of ox or sheep, 269  
Levatores costarum, 15  
Lever for frog's heart, 349  
Liebig's method of estimating  
urea, 398  
Lieno-gastric veins, 5 ; artery, 6  
Lieberkühn, glands of, 179  
Ligamentum pectinalium iridis,  
267  
Ligamentum nuchae, 58  
Limbic lobe, 324  
Linea alba, of dog and rabbit, 1  
Lingual nerves, 26  
Liver, dissection of, 7 ; histology,  
204  
Longissimus dorsi, 15  
Lumbar fascia, 2  
Lung, structure of, 211 ; injection  
with silver nitrate, 216, 217  
Lymph-channels, 193  
Lymph follicles of intestine, 180  
Lymph-hearts of frog, 120  
Lymph-sinus, 191  
Lymphatic capillaries, structure  
of, 200  
Lymphatic-glands, structure of,  
191 ; method of hardening, 192

## M.

- Malleus, posterior ligament of,  
296 ; anterior ligament of, 296 ;  
axis band of, 296

- Malpighian corpuscles, 195, 197,  
199  
Malpighian layer of epidermis,  
247  
Mammary glands, dissection in  
rabbit, 1  
Masseter muscle, 25  
Maxillary nerve, inferior, 28 ;  
superior, 31  
Maxwell's method of detecting  
yellow spot, 284  
Measurement of microscopic ob-  
jects, 37, 354  
Mechanical stimulation of nerve,  
94  
Mediastinum, 16  
Medulla oblongata, 11, 309  
Medullary sheath of nerves, 105 ;  
-cords of lymphatic glands, 193 ;  
-rays of kidney, 229  
Medullated nerve-fibres, 105  
Membrana granulosa, 337  
Membrane, mucous (Schneiderian),  
30 ; hyaloid, 265 ; of Descemet,  
269 ; inner limiting, 271 ; outer  
limiting, 273 ; tympanic, 295 ;  
basilar, 299 ; of Reissner, 299  
Membranous semicircular canal,  
291  
Mercurial manometer, the, 148  
Mesenteric lymphatic glands, 4 ;  
veins, 5  
Mesentery, of dog and rabbit, 3 ;  
nerves in, 109  
Methylene blue, 375  
Micrometer, ocular, 354  
Microscope, magnifying power of,  
35, 355 ; notes on use of, 351,  
352  
Microtome, 368 389  
Millon's reagent, 381  
Milk, fat globules in, 174 ; alkali-  
nity of, 175 ; albumin in, 175 ;  
casein in, 175, 176 ; fermenta-  
tion of, 176  
Mitral valve, 140  
Modiolus, 298  
Moist chamber, 348  
Molecular layers, retina, 273  
Monro, foramen of, 318  
Morse key, 345

Mounting, 378, in glycerine, 55;  
 method for thin membrane, 59;  
 in Canada balsam, 66  
 Mucin, 161; of bile, 184  
 Mucous cells, of salivary glands,  
 156; of stomach, 168; of in-  
 testine, 179  
 Mucous coat of stomach, 168, 214  
 Mucous membrane, stomach of  
 rabbit, 9  
 Müller, fibres of, 272  
 Müller's fluid, 362  
 Murexide test, for uric acid, 240  
 Muscle, pectoral, 14; external  
 intercostal, 15; internal inter-  
 costal, 16; masseter, 25; digas-  
 tric, 26, 27; mylohyoid, 26, 27;  
 structure of, 82, 85, 88; reaction  
 of, 98, 99; ciliary, 264; tensor  
 tympani, 297; stapedius, 298;  
 arytenoid, 334  
 Muscular coat of stomach, 168  
 Muscular contraction, in frog, 94,  
 95  
 Mylohyoid muscle, 26, 27  
 Myosin, 100, 101

## N.

Nasal bones of rabbit, 30  
 Negative after-image, 286  
 Nerve fibres, method of harden-  
 ing, 34; medullated, 105; non-  
 medullated, 108  
 Nerve-muscle preparation, 95  
 Nervoussystem. Splanchnic nerve,  
 4, 5, 21; pneumogastric nerves,  
 5, 18, 27, 29, 142; cranial, 11;  
 optic nerve, of rabbit, 12; of  
 sheep, 264; fourth and fifth  
 nerve, 12; ninth, tenth, eleventh  
 and twelfth, 13; phrenic nerve,  
 17, 19; sympathetic, 18; superi-  
 or cardiac, 18; crural, 23; facial,  
 24; sciatic, 24, 91, 95; auricular,  
 of rabbit, 25; lingual, 26; pha-  
 ryngeal, 27; hypoglossal, 28,  
 29; inferior maxillary, 28; in-  
 ferior dental, 28; glossopharyn-  
 geal, 29, 142; spinal accessory,  
 29; Jacobson's, 29; olfactory,

30; ophthalmic, 31; superior  
 maxillary, 31; trigeminal, 32;  
 superficial origin of, 314  
 Nodes of Ranvier, 106, 107  
 Normal fluids, 52, 356  
 Nuclear layers, retina, 273  
 Nucleus, of cells (hyaline carti-  
 lage), 52, 53; of primitivesheath,  
 107; of capsule of nerve cells,  
 111; of capillaries, 128; of ad-  
 ventitia, 128; of salivary glands,  
 158, 159; of alveolar cells of  
 lung, 212; caudatus, 316, 323;  
 lenticularis, 323

## O.

Obliquus externus abdominis, 2  
 Oleic acid, action of bile on, 186;  
 effect on pancreatic digestion,  
 189  
 Oesophagus, of dog and rabbit, 2,  
 7; structure of, 170, 171  
 Olfactory, lobes, 11, 324; nerves,  
 30; mucous membrane, struc-  
 ture of, 257 ff; bulb, 323; tract,  
 324  
 Olivary bodies, inferior, 311  
 Omentum, 3  
 Optic, fibres, layer of, 272; tracts,  
 312; chiasma, 312; thalamus,  
 319  
 Optic nerve of rabbit, 12  
 Ora serrata, 265  
 Orbital gland, 31; lobe, 326  
 Oscillating rod, 349  
 Osmic acid, for dissociating tis-  
 sues, 358; general directions  
 for use, 363  
 Ossification, 75  
 Osteoblasts, 76, 77  
 Osteoclasts, 76  
 Ovary, dissection, 10; histology,  
 336  
 Ovoid cells of stomach, 168  
 Ovum, 337

## P.

Pacinian bodies, 252  
 Pancreas, dissection, 3, 6; histo-  
 logy, 159, 160

- Pancreatic duct, 3, 4; arteries, 6; veins, 6; juice, artificial, 188  
 Papilla foliata, of rabbit, 32; structure of, 259 ff  
 Papillae, of skin, 247  
 Parotid gland, 24; duct of, 25  
 Paraglobulin, 48  
 Parovarium, 339  
 Paraffin, 367, 368  
 Pectoral muscle, 14  
 Pelvis of sheep's kidney, 228  
 Pepsin, preparation of, 171; destruction of by acid, 173  
 Peptone, characters of, 174  
 Perforated space, posterior, 311  
 Pericardium, 17  
 Perichondrium, 64  
 Periosteum, 77  
 Peripheral zone of blood current, 131  
 Peritoneum, 3  
 Pettenkofer's test, for bile acids, 185, 242  
 Peyer's patches, 8, 180, 191  
 Pharyngeal nerve, 27  
 Phrenic nerve, 17, 19  
 Pia mater, 11, 129, 301, 308  
 Picric acid, 362  
 Pigment-cells, of frog's web, 65; of retina, 274  
 Pigment of choroid, 273  
 Pineal gland, 320; peduncles of, 320  
 Pituitary body, 312  
 Plasma of blood, 45, 46  
 Plasmine, 47  
 Platysma, 18  
 Pleura, 16, 17  
 Pneumogastric trunks, 20; nerves, 5, 18, 22, 23, 27, 28, 142; superior laryngeal branch of, 18; pharyngeal branch of, 27  
 Pons Varolii, 311  
 Portal vein, 5, 7  
 Positive after-image, 285  
 Posterior root of spinal nerve of rabbit, 13, 302; columns, 302  
 Preserving agents, method of using, 359; to make solutions, 360  
 Primary nerve-plexus, 250  
 Primitive sheath, 105  
 Processus gracilis of malleus, 296  
 Proteids, general reactions of, 49; in saliva, 161  
 Ptyalin, to prepare extract of, 165; destruction of by acid, 165  
 Pulmonary arteries and veins, 21, 137  
 Pulse waves, progression of, 151  
 Purkinje's figures, 282  
 Pyloric glands, 170  
 Pyramids, anterior, 311
- Q.
- Quantitative estimation of urca, hypobromite method, 242, 400
- R.
- Rabbit, dissection of, 1  
 Rami communicantes, 21  
 Ranvier, nodes of, 106, 107  
 Recti abdominis, 2  
 Rectum, 3, 7  
 Red corpuscles, method of counting, 42  
 Reflex action, 116  
 Reil, island of, 326  
 Reissner's membrane, 299  
 Renal, artery, 4; vein, 5  
 Rennet-ferment, 176  
 Restiform body, 309  
 Rete testis, 341  
 Retina, dissection of, 264; histology of, 271  
 Rigor mortis, 99  
 Rima glottidis, 331  
 Rod cells of olfactory mucous membrane, 257; of taste-buds, 261  
 Roots of spinal nerves, 13
- S.
- Sacculus of semicircular canals, 292  
 Saline solution, normal, 357  
 Saliva, 161

- Salivary glands, structure of, mucous, 155; serous, 158  
 Sartorius muscle, rabbit, 23  
 Scalenus medius, 15; — anticus, 15; — posticus, 15  
 Scheiner's experiment, 278  
 Schneiderian membrane, 30  
 Sciatic nerve, 24, 91  
 Sebaceous gland, 249  
 Section cutting, 368  
 Semicircular canals of ear, 290 ff  
 Septum auricularum, in heart of sheep, 138; in heart of frog, 145; structure of in frog, 144  
 Septum lucidum, 317, 322  
 Serratus anticus, major, 14; minor, 15; serratus posticus, 15  
 Serum, iodized, 357, 358  
 Sigmoid gyrus, 325  
 Silver nitrate, 125, 130, 197, 217, 377  
 Skin, histology, 246  
 Smell, 261  
 Solar plexus, 4, 5  
 Solutions, preparation of, 360  
 Spectrum of haemoglobin, 222  
 Spermaceti and castor oil, 368  
 Spermatozoa, 344  
 Sphincter pupillae, 271  
 Sphygmograph, 150  
 Spiller's purple; to stain red corpuscles with, 39; to stain connective-tissue cells, 60, 375  
 Spinal accessory nerve, 29  
 Spinal cord, 114, 301; structure of, 110; method of hardening, 301  
 Spinal ganglion, dissection of, 14; structure of, 110  
 Spiral process of nerve cells, 145  
 Splanchnic nerves, 5, 21  
 Spleen, dissection, 3; histology, 194, 195; method of hardening, 196; method of injecting, 197; Malpighian corpuscles of, 197, 199  
 Splenic artery, 6; pulp, 195, 196  
 Stapedius muscle, 293  
 Stapes, 297, 298  
 Starch mucilage, preparation of, 162  
 Sterno-cleido-mastoid muscle, 22  
 Sterno-hyoid muscle, 21  
 Sterno-mastoid muscle, 18  
 Sterno-thyroid muscle, 22  
 Stokes' fluid, 382, 383  
 Stomach, of dog and rabbit, 2, 8; method of hardening, 32; structure of, 167, 168  
 Stomata, 201  
 Stylo-mastoid foramen, 25  
 Subclavian veins, 19, 20  
 Sub-epithelial nerve plexus, 251  
 Sublingual gland, 26; — duct, 26, 27  
 Submaxillary gland, dissection, 26, 27; duct, 26, 27; histology, 155  
 Substantia gelatinosa, 303  
 Substantia nigra, 322  
 Sugar, quantitative estimation in urine, 243  
 Superior mesenteric artery, 4  
 Superior vena cava, dog, 22  
 Suprarenal body, 4  
 Sweat-glands, 250  
 Sylvius, aqueduct of, 313; fissure of, 324  
 Sympathetic ganglia, dissection of, 20, 21, 28; structure of, 113  
 Sympathetic nerve in neck of dog, 22, 23, 28; in rabbit, 18, 20, 28  
 Syntonin, 101, 102
- T.
- Tactile delusions, 256  
 Tail, of tadpole, 60; of mouse, 58, 62  
 Taste, 261  
 Taste-buds, 260  
 Teasing, 357  
 Teeth, structure of, 77  
 Tegmentum, 322  
 Temperature, sensation of, 254  
 Tendon, 62  
 Tensor tympani muscle, 297  
 Tentorium, 11  
 Testis, 10, 340  
 Tetanus, 97  
 Thalamus, optic, 319

- Thoracic duct of dog, 17  
 Thoracic ganglion, 20  
 Thymus, 19  
 Thyro-arytenoid muscle, 334, 335  
 Thyro-hyoid muscle, 22  
 Thyroid, gland, 23; cartilage, 332  
 Time marker, 350  
 Touch, 254  
 Touch-corpules, 252  
 Trachea, histology of, 213  
 Transversalis abdominis, 2  
 Tricuspid valve, 138  
 Trigeminal nerve, 32  
 Trommer's test, 162, 163  
 Tuber cinereum, 311  
 Tubuli seminiferi, 341, 342  
 Tunica albuginea, 340  
 Tunica vaginalis, 10; propria, 340  
 Turpentine, 378  
 Tympanic membrane, 295
- U.
- Uncinate lobe, 324  
 Unstriated muscle, structure of, 86, 87  
 Urea, 237; crystals of, 237; nitrate of, 237; oxalate of, 237  
 Ureter, dissection, 9; histology, 228; structure of, 235  
 Uric acid, 240  
 Urinary bladder, 10  
 Urine, acid in, 237; alkaline fermentation in, 237; mucus in, 237; albumin in, 241; sugar in, 241  
 Uterus, 10, 340  
 Utriculus, 291  
 Uvea, 270
- V.
- Valsalva, sinuses of, 139  
 Vas deferens, 10, 343  
 Vasa efferentia, 341, 343
- Veins, renal, 4; portal, 5; lieno-gastric and mesenteric, 5; portal, 5; gastric and pancreatic, 6; external jugular, 19; subclavian, 19, 20; pulmonary, 21, 137; innominate, 22; femoral, 23; structure of, 127; azygos in heart of sheep, 138; coronary, 138; interlobular, 234  
 Velum interpositum, 318  
 Vena cava, inferior, 4, 19, 121, 137, 142; superior, 19, 121, 137, 142  
 Ventricle, fourth, 309, 310; lateral, 316; fifth, 317; third, 319; 320  
 Vertebral artery, 20, 313  
 Vieussens, valve of, 310  
 Villi, 9; structure of, 178, 181  
 Vision, region of distinct, 282; region of normal colour, 285  
 Visual judgments, 289  
 Vitreous humour, 265
- W.
- Weight, estimation of, 254, 255  
 Willis, circle of, 314
- X.
- Xanthoproteic reaction, 49, 50, 174
- Y.
- Yellow spot, 284
- Z.
- Zeiss, camera-lucida of, 352, 353  
 Zinn, zone of, 266  
 Zona pellucida, 338, 339  
 Zones of pancreatic gland-cells, 160

## ADDITIONS TO INDEX.

- Blood corpuscles, white, of frog;  
method of obtaining, 43
- Celloidin, 390
- Farrant's solution, 394
- Flemming's mixture, 388
- Glycerine jelly, 392
- Hæmatoxylin, Delafield's, 395
- Imbedding in paraffin, 388
- Mercuric chloride, 387
- Mounting ribbons of sections, 389
- Nerve-fibres, staining by Weigert's  
method, 396
- Nitrate of silver, treatment of  
preparations, 394
- Nuclear division, methods of  
staining for, 395
- Osmic acid, staining after, 394
- Platelets of blood, 387
- Ribbons of sections, 388
- Sympathetic ganglia, dissection  
of 23, 113; isolation of cells,  
112, 115
- Vienssens, annulus of, 23
- Weigert's method of staining  
nerve-fibres, 396

Cambridge

PRINTED BY C. J. CLAY, M.A. & SONS

AT THE UNIVERSITY PRESS,



# Messrs. MACMILLAN and Co's Publications.

WORKS BY MICHAEL FOSTER, M.D., F.R.S,  
PROFESSOR OF PHYSIOLOGY IN THE UNIVERSITY OF CAMBRIDGE.

**A Text-Book of Physiology.** With Illustrations. Fourth Edition, revised. 8vo. 21s.

The *Lancet* says:—"Dr Foster has combined in this work the conflicting desiderata in all text-books—comprehensiveness, brevity, and clearness....After a careful perusal of the entire work, we can confidently recommend it, both to the student and the practitioner as being one of the best text-books on physiology extant, the facts recorded as being reliable, as the reasonings are sound, whilst the arrangement and style are alike excellent."

The *British Medical Journal* says:—"It is not often that medical literature is enriched by a book which promises to be of such permanent value."

**Primer of Physiology.** With numerous Illustrations. New Edition. 18mo. 1s. [*Science Primers.*]

**The Elements of Embryology.** By Professor MICHAEL FOSTER, M.A., F.R.S., and the late F. M. BALFOUR, F.R.S. Second Edition, revised and enlarged. Edited by ADAM SEDGWICK, M.A., and WALTER HEAPE. With Illustrations. Crown 8vo. 10s. 6d.

The *British Medical Journal* says:—"This book is not written to air the opinions, however valuable, of its authors among a select circle of embryologists, nor prepared solely to enlarge the scientific reputation of either of them. It has a far more valuable and worthy object. It is a practical guide to students; it may be placed in the hand of any tolerably well instructed second-year's man in a London School, or in our Universities, with the certainty that, if the ordinary appliances of a histological laboratory be at his disposal, and if he follow the instructions and master the discussions here put forward, he cannot fail, by the expenditure of a very small amount of time and industry, to obtain a really solid knowledge of the modes of thought and the modes of experiment which belong to the science of embryology—a science which all biologists admit to be of first rate importance, and of which, we must say, very few indeed in this country have any true first hand knowledge."

## MANUALS FOR STUDENTS.

**An Atlas of Practical Elementary Biology.** By G. B. HOWES, Assistant Professor of Zoology, Normal School of Science and Royal School of Mines. With a Preface by THOMAS HENRY HUXLEY, F.R.S. Royal 4to. 14s.

**Lessons in Elementary Physiology.** By THOMAS HENRY HUXLEY, F.R.S. With numerous Illustrations. New Edition, Revised. Fcap. 8vo. 4s. 6d. Questions, 1s. 6d.

**A Manual of Elementary Practical Histology.** By WILLIAM FEARNLEY. Illustrated. Crown 8vo. 7s. 6d.

**Heat.** By P. G. TAIT, M.A., Sec. R.S.E. Crown 8vo. 6s.

**Elementary Practical Physics, Lessons in.** By BALFOUR STEWART, M.A., LL.D., F.R.S., and W. W. HALDANE GEE, B.Sc. Crown 8vo.

Part I. GENERAL PHYSICAL PROCESSES. 6s. Part II. ELECTRICITY AND MAGNETISM. 7s. 6d. Part III. OPTICS, HEAT, AND SOUND.

[*In preparation.*]

**On Light.** Being the Burnett Lectures, delivered in Aberdeen in 1883—1884. By GEORGE GABRIEL STOKES, M.A., P.R.S., etc. First Course.—ON THE NATURE OF LIGHT. Second Course.—ON LIGHT AS A MEANS OF INVESTIGATION. Third Course.—ON THE BENEFICIAL EFFECTS OF LIGHT. Crown 8vo. 7s. 6d.

MACMILLAN AND CO., LONDON.

# Messrs. **MACMILLAN** and Co.'s Publications.

## MANUALS FOR STUDENTS.

- Organic Chemistry, or an Introduction to the Study of the Compounds of Carbon.** By IRA REMSEN, Professor of Chemistry in the Johns Hopkins University. Crown 8vo. 6s. 6d.
- An Introduction to the Study of Chemistry (Inorganic Chemistry).** By IRA REMSEN. Crown 8vo. 6s. 6d.
- A Course of Instruction in Zootomy (Vertebrata).** By T. JEFFREY PARKER, B.Sc. With Illustrations. Crown 8vo. 8s. 6d.
- The Morphology of the Skull.** By Professor PARKER and G. T. BETTANY. Illustrated. Crown 8vo. 10s. 6d.
- A Course of Practical Instruction in Elementary Biology.** By T. H. HUXLEY, F.R.S., assisted by H. N. MARTIN, B.A., M.B. D.Sc. New Edition, revised and extended by G. B. HOWES and D. H. SCOTT. Crown 8vo. 10s. 6d.
- The Osteology of the Mammalia, an Introduction to.** By WILLIAM HENRY FLOWER, LL.D., F.R.S. Third Edition. Revised with the assistance of HANS GADOW, Ph.D. Crown 8vo. 10s. 6d.
- Class-Book of Geology.** By ARCHIBALD GEIKIE, F.R.S. With 200 new Illustrations. Crown 8vo. 10s. 6d.
- A Course of Practical Instruction in Botany.** By Professor F. O. BOWER, D.Sc., F.L.S. New and Revised Edition. Crown 8vo. Part I.—PHANEROGAMÆ—PTERIDOPHYTA. 6s. 6d. Part II.—BRYOPHYTA—THALLOPHYTA. 4s. 6d. Or complete in one Volume. 10s. 6d.
- The Student's Flora of the British Islands.** By Sir J. D. HOOKER, K.C.S.I., C.B., M.D., F.R.S. Third Edition. Globe 8vo. 10s. 6d.
- Structural Botany; or, Organography on the Basis of Morphology.** To which are added the Principles of Taxonomy and Phytography, and a Glossary of Botanical Terms. By Prof. ASA GRAY. 10s. 6d.
- A Handbook of European Butterflies.** By F. DE VISMES KANE, M.A., F.E.S.L. With Illustrations. 10s. 6d.
- Physiography.** An Introduction to the Study of Nature. By THOMAS HENRY HUXLEY, F.R.S. New Edition. Crown 8vo. 6s.
- Agricultural Chemical Analysis, a Handbook of.** By PERCY FARADAY FRANKLAND, Ph.D., B.Sc., F.S.C. Founded upon *Leitfaden für die Agricultur-Chemische Analyse*, von Dr F. KROCKER. Crown 8vo. 7s. 6d.
- Marine Surveying, an Elementary Treatise on.** Prepared for the use of Younger Naval Officers. By Rev. JOHN L. ROBINSON. Crown 8vo. 7s. 6d.
- Micro-Organisms and Disease: An Introduction to the Study of Specific Micro-Organisms.** By E. KLEIN, M.D., F.R.S. With 121 Engravings. Third Edition, Revised. Crown 8vo. 6s.
- Outlines of the History of Ethics for English Readers.** By HENRY SIDGWICK, M.A., LL.D. Crown 8vo. 3s. 6d.

MACMILLAN AND CO., LONDON.

*September, 1889*

A Catalogue  
OF  
Educational Books

PUBLISHED BY

Macmillan & Co.

BEDFORD STREET, STRAND, LONDON.

The following Elementary Books, with Introductions, Notes, and **Vocabularies**, and in some cases with **Exercises**, are either ready or in preparation:—

**Aeschylus.**—**PROMETHEUS VINCTUS.** Edited by Rev. H. M. STEPHENSON, M.A.

**Arrian.**—**SELECTIONS.** Edited for the use of Schools, with Introduction, Notes, Vocabulary, and Exercises, by Rev. JOHN BOND, M.A., and A. S. WALPOLE, M.A.

**Aulus Gellius, Stories from.** Being Selections and Adaptations from the *Noctes Atticae*. Edited, with Exercises for the use of Lower Forms, by Rev. G. H. NALL, M.A., Assistant Master in Westminster School.

**Cæsar.**—**THE HELVETIAN WAR.** Being Selections from Book I. of the "De Bello Gallico." Adapted for the use of Beginners. With Notes, Exercises, and Vocabulary, by W. WELCH, M.A., and C. G. DUFFIELD, M.A.

**THE INVASION OF BRITAIN.** Being Selections from Books IV. and V. of the "De Bello Gallico." Adapted for the use of Beginners. With Notes, Vocabulary, and Exercises, by W. WELCH, M.A., and C. G. DUFFIELD, M.A.

**THE GALLIC WAR. BOOK I.** Edited by A. S. WALPOLE, M.A.

**THE GALLIC WAR. BOOKS II. AND III.** Edited by the Rev. W. G. RUTHERFORD, M.A., LL.D., Head-Master of Westminster.

**THE GALLIC WAR. BOOK IV.** Edited by CLEMENT BRYANS, M.A., Assistant-Master at Dulwich College.

**THE GALLIC WAR. SCENES FROM BOOKS V. AND VI.** Edited by C. COLBECK, M.A., Assistant-Master at Harrow; formerly Fellow of Trinity College, Cambridge.

**THE GALLIC WAR. BOOKS V. AND VI. (separately).** By the same Editor. Book V. *ready*. Book VI. *in preparation*.

**THE GALLIC WAR. BOOK VII.** Edited by Rev. JOHN BOND, M.A., and A. S. WALPOLE, M.A.

**Cicero.**—**DE SENECTUTE.** Edited by E. S. SHUCKBURGH, M.A., late Fellow of Emmanuel College, Cambridge.

**DE AMICITIA.** By the same Editor.

**STORIES OF ROMAN HISTORY.** Adapted for the Use of Beginners. With Notes, Vocabulary, and Exercises, by the Rev. G. E. JEANS, M.A., Fellow of Hertford College, Oxford, and A. V. JONES, M.A.; Assistant-Masters at Haileybury College.

**Eutropius.**—Adapted for the Use of Beginners. With Notes, Vocabulary, and Exercises, by WILLIAM WELCH, M.A., and C. G. DUFFIELD, M.A., Assistant-Masters at Surrey County School, Cranleigh.

**Homer.**—**ILIAD. BOOK I.** Edited by Rev. JOHN BOND, M.A., and A. S. WALPOLE, M.A.

- Homer.**—ILIAD. BOOK XVIII. THE ARMS OF ACHILLES. Edited by S. R. JAMES, M.A., Assistant-Master at Eton College.
- ODYSSEY. BOOK I. Edited by Rev. JOHN BOND, M.A. and A. S. WALPOLE, M.A.
- Horace.**—ODES. BOOKS I.—IV. Edited by T. E. PAGE, M.A., late Fellow of St. John's College, Cambridge; Assistant-Master at the Charterhouse. Each 1s. 6d.
- Latin Accidence and Exercises Arranged for BEGINNERS.** By WILLIAM WELCH, M.A., and C. G. DUFFIELD, M.A., Assistant Masters at Surrey County School, Cranleigh.
- Livy.**—BOOK I. Edited by H. M. STEPHENSON, M.A., late Head Master of St. Peter's School, York.
- BOOKS XXI. and XXII. (separately), with Notes adapted from Mr. Capes' Edition, for the use of junior students, and with Vocabularies by J. E. MELHUISE, M.A., Assistant-Master in St. Paul's School. *[In the press.]*
- THE HANNIBALIAN WAR. Being part of the XXI. AND XXII. BOOKS OF LIVY, adapted for the use of beginners, by G. C. MACAULAY, M.A., late Fellow of Trinity College, Cambridge.
- THE SIEGE OF SYRACUSE. Being part of the XXIV. AND XXV. BOOKS OF LIVY, adapted for the use of beginners. With Notes, Vocabulary, and Exercises, by GEORGE RICHARDS, M.A., and A. S. WALPOLE, M.A.
- LEGENDS OF EARLY ROME. Adapted for the use of beginners. With Notes, Exercises, and Vocabulary, by HERBERT WILKINSON, M.A. *[In preparation.]*
- Lucian.**—EXTRACTS FROM LUCIAN. Edited, with Notes, Exercises, and Vocabulary, by Rev. JOHN BOND, M.A., and A. S. WALPOLE, M.A.
- Nepos.**—SELECTIONS ILLUSTRATIVE OF GREEK AND ROMAN HISTORY. Edited for the use of beginners with Notes, Vocabulary and Exercises, by G. S. FARNELL, M.A.
- Ovid.**—SELECTIONS. Edited by E. S. SHUCKBURGH, M.A., late Fellow and Assistant-Tutor of Emmanuel College, Cambridge.
- EASY SELECTIONS FROM OVID IN ELEGIAC VERSE. Arranged for the use of Beginners with Notes, Vocabulary, and Exercises, by HERBERT WILKINSON, M.A.
- STORIES FROM THE METAMORPHOSES. Edited for the Use of Schools. With Notes, Exercises, and Vocabulary. By J. BOND, M.A., and A. S. WALPOLE, M.A.
- Phædrus.**—SELECT FABLES. Adapted for the Use of Beginners. With Notes, Exercises, and Vocabularies, by A. S. WALPOLE, M.A.
- Thucydides.**—THE RISE OF THE ATHENIAN EMPIRE. BOOK I. CC. LXXXIX. — CXVII. AND CXXVIII. — CXXXVIII. Edited with Notes, Vocabulary and Exercises, by F. H. COLSON, M.A., Senior Classical Master at Bradford Grammar School; Fellow of St. John's College, Cambridge.

- Virgil.**—ÆNEID. BOOK I. Edited by A. S. WALPOLE, M.A.  
 ÆNEID. BOOK II. Edited by T. E. PAGE, M.A., Assistant-  
 Master at the Charterhouse.  
 ÆNEID. BOOK III. Edited by T. E. PAGE, M.A. [*In preparation.*]  
 ÆNEID. BOOK IV. Edited by Rev. H. M. STEPHENSON,  
 M.A.  
 ÆNEID. BOOK V. Edited by Rev. A. CALVERT, M.A.,  
 late Fellow of St. John's College, Cambridge.  
 ÆNEID. BOOK VI. Edited by T. E. PAGE, M.A.  
 ÆNEID. BOOK VII. Edited by A. CALVERT, M.A.  
 ÆNEID. BOOK IX. Edited by Rev. H. M. STEPHENSON,  
 M.A. [*In the press.*]  
 GEORGICS. BOOK I. Edited by T. E. PAGE, M.A. [*In the press.*]  
 SELECTIONS. Edited by E. S. SHUCKBURGH, M.A.
- Xenophon.**—ANABASIS. BOOK I. Edited by A. S.  
 WALPOLE, M.A.  
 ANABASIS. BOOK I. Chaps. I.—VIII. for the use of Beginners,  
 with Titles to the Sections, Notes, Vocabulary, and Exercises, by  
 E. A. WELLS, M.A., Assistant Master in Durham School.  
 ANABASIS. BOOK II. Edited by A. S. WALPOLE, M.A.  
 ANABASIS, SELECTIONS FROM. BOOK IV. THE RE-  
 TREAT OF THE TEN THOUSAND. Edited, with Notes,  
 Vocabulary, and Exercises, by Rev. E. D. STONE, M.A., formerly  
 Assistant-Master at Eton.  
 SELECTIONS FROM THE CYROPÆDIA. Edited, with  
 Notes, Vocabulary, and Exercises, by A. H. COOKE, M.A., Fellow  
 and Lecturer of King's College, Cambridge.

The following more advanced Books, with Introductions  
 and Notes, but no Vocabulary, are either ready, or in  
 preparation:—

- Cicero.**—SELECT LETTERS. Edited by Rev. G. E. JEANS,  
 M.A., Fellow of Hertford College, Oxford, and Assistant-Master  
 at Haileybury College.
- Euripides.**—HECUBA. Edited by Rev. JOHN BOND, M.A.  
 and A. S. WALPOLE, M.A.
- Herodotus.**—SELECTIONS FROM BOOKS VII. AND VIII.  
 THE EXPEDITION OF XERXES. Edited by A. H. COOKE,  
 M.A., Fellow and Lecturer of King's College, Cambridge.
- Horace.**—SELECTIONS FROM THE SATIRES AND  
 EPISTLES. Edited by Rev. W. J. V. BAKER, M.A., Fellow of  
 St. John's College, Cambridge.  
 SELECT EPODES AND ARS POETICA. Edited by H. A.  
 DALTON, M.A., formerly Senior Student of Christchurch; Assistant-  
 Master in Winchester College.

**Plato.**—EUTHYPHRO AND MENEXENUS. Edited by C. E. GRAYES, M.A., Classical Lecturer and late Fellow of St. John's College, Cambridge.

**Terence.**—SCENES FROM THE ANDRIA. Edited by F. W. CORNISH, M.A., Assistant-Master at Eton College.

**The Greek Elegiac Poets.**—FROM CALLINUS TO CALLIMACHUS. Selected and Edited by Rev. HERBERT KYNASTON, D.D., Principal of Cheltenham College, and formerly Fellow of St. John's College, Cambridge.

**Thucydides.**—BOOK IV. CHS. I.—XLI. THE CAPTURE OF SPHACTERIA. Edited by C. E. GRAYES, M.A.

**Virgil.**—GEORGICS. BOOK II. Edited by Rev. J. H. SKRINE, M.A., late Fellow of Merton College, Oxford; Warden of Trinity College, Glenalmond.

\* \* \* *Other Volumes to follow.*

## CLASSICAL SERIES FOR COLLEGES AND SCHOOLS.

Fcap. 8vo.

Being select portions of Greek and Latin authors, edited with Introductions and Notes, for the use of Middle and Upper forms of Schools, or of candidates for Public Examinations at the Universities and elsewhere.

**Æschines.**—IN CTESIPHONTEM. Edited by Rev. T. GWATKIN, M.A., late Fellow of St. John's College, Cambridge, and E. S. SHUCKBURGH, M.A. *[In the press.]*

**Æschylus.**—PERSÆ. Edited by A. O. PRICKARD, M.A. Fellow and Tutor of New College, Oxford. With Map. 3s. 6d.  
SEVEN AGAINST THEBES. SCHOOL EDITION, Edited by A. W. VERRALL, Litt.D., Fellow of Trinity College, Cambridge, and M. A. BAYFIELD, M.A., Head-Master's Assistant at Malvern College. 3s. 6d.

**Andocides.**—DE MYSTERIIS. Edited by W. J. HICKIE, M.A., formerly Assistant-Master in Denstone College. 2s. 6d.

**Attic Orators.**—Selections from ANTIPHON, ANDOCIDES, LYSIAS, ISOCRATES, AND ISAEUS. Edited by R. C. JEBB, Litt.D., LL.D., Professor of Greek in the University of Cambridge. Second Edition. 6s.

**Cæsar.**—THE GALLIC WAR. Edited, after Kraner, by Rev. JOHN BOND, M.A., and A. S. WALPOLE, M.A. With Maps. 6s.

**Catullus.**—SELECT POEMS. Edited by F. P. SIMPSON, B.A., late Scholar of Balliol College, Oxford. New and Revised Edition. 5s. The Text of this Edition is carefully adapted to School use.

**Cicero.**—THE CATILINE ORATIONS. From the German of KARL HALM. Edited, with Additions, by A. S. WILKINS, Litt.D., LL.D., Professor of Latin at the Owens College, Manchester, Examiner of Classics to the University of London. New Edition. 3s. 6d.

PRO LEGE MANILIA. Edited, after HALM, by Professor A. S. WILKINS, Litt.D., LL.D. 2s. 6d.

THE SECOND PHILIPPIC ORATION. From the German of KARL HALM. Edited, with Corrections and Additions, by JOHN E. B. MAYOR, Professor of Latin in the University of Cambridge, and Fellow of St. John's College. New Edition, revised. 5s.

PRO ROSCIO AMERINO. Edited, after HALM, by E. H. DONKIN, M.A., late Scholar of Lincoln College, Oxford; Assistant-Master at Sherborne School. 4s. 6d.

PRO P. SESTIO. Edited by Rev. H. A. HOLDEN, M.A., LL.D., late Fellow of Trinity College, Cambridge; and late Classical Examiner to the University of London. 5s.

**Demosthenes.**—DE CORONA. Edited by B. DRAKE, M.A., late Fellow of King's College, Cambridge. New and revised Edition, edited by E. S. SHUCKBURGH, M.A. [*In the press.*]

ADVERSUS LEPTINEM. Edited by Rev. J. R. KING, M.A., Fellow and Tutor of Oriel College, Oxford. 4s. 6d.

THE FIRST PHILIPPIC. Edited, after C. REHDANTZ, by Rev. T. GWATKIN, M.A., late Fellow of St. John's College, Cambridge. 2s. 6d.

IN MEDIUM. Edited by Prof. A. S. WILKINS, Litt.D., LL.D., and HERMAN HAGER, Ph.D., of the Owens College, Manchester. [*In preparation.*]

**Euripides.**—HIPPOLYTUS. Edited by J. P. MAHAFFY, M.A., Fellow and Professor of Ancient History in Trinity College, Dublin, and J. B. BURY, Fellow of Trinity College, Dublin. 3s. 6d.

MEDEA. Edited by A. W. VERRALL, Litt.D., Fellow and Lecturer of Trinity College, Cambridge. 3s. 6d.

IPHIGENIA IN TAURIS. Edited by E. B. ENGLAND, M.A., Lecturer at the Owens College, Manchester. 4s. 6d.

ION. Edited by M. A. BAYFIELD, M.A., Headmaster's Assistant at Malvern College. 3s. 6d.

BACCHAE. Edited by R. Y. TYRRELL, M.A., Professor of Greek in the University of Dublin. [*In preparation.*]

**Herodotus.**—BOOK III. Edited by G. C. MACAULAY, M.A., formerly Fellow of Trinity College, Cambridge. [*In preparation.*]

BOOKS V. AND VI. Edited by J. STRACHAN, M.A., Professor of Greek in the Owens College, Manchester. [*In preparation.*]

BOOKS VII. AND VIII. Edited by Mrs. MONTAGU BUTLER. [*In the press.*]

**Hesiod.**—THE WORKS AND DAYS. Edited by W. T. LENDRUM, Assistant Master in Dulwich College. [*In preparation.*]



- Homer.**—ILIAD. BOOKS I., IX., XI., XVI.—XXIV. THE STORY OF ACHILLES. Edited by the late J. H. PRATT, M.A., and WALTER LEAF, Litt.D., Fellows of Trinity College, Cambridge. 6s.
- ODYSSEY. BOOK IX. Edited by Prof. JOHN E. B. MAYOR. 2s. 6d.
- ODYSSEY. BOOKS XXI.—XXIV. THE TRIUMPH OF ODYSSEUS. Edited by S. G. HAMILTON, B.A., Fellow of Hertford College, Oxford. 3s. 6d.
- Horace.**—THE ODES. Edited by T. E. PAGE, M.A., formerly Fellow of St. John's College, Cambridge; Assistant-Master at the Charterhouse. 6s. (BOOKS I., II., III., and IV. separately, 2s. each.)
- THE SATIRES. Edited by ARTHUR PALMER, M.A., Fellow of Trinity College, Dublin; Professor of Latin in the University of Dublin. 6s.
- THE EPISTLES AND ARS POETICA. Edited by A. S. WILKINS, Litt.D., LL.D., Professor of Latin in Owens College, Manchester; Examiner in Classics to the University of London. 6s.
- Isaëos.**—THE ORATIONS. Edited by WILLIAM RIDGEWAY, M.A., Fellow of Caius College, Cambridge; and Professor of Greek in the University of Cork. [*In preparation.*]
- Juvenal.** THIRTEEN SATIRES. Edited, for the Use of Schools, by E. G. HARDY, M.A., late Fellow of Jesus College, Oxford. 5s.
- The Text of this Edition is carefully adapted to School use.
- SELECT SATIRES. Edited by Professor JOHN E. B. MAYOR. X. AND XI. 3s. 6d. XII.—XVI. 4s. 6d.
- Livy.**—BOOKS II. AND III. Edited by Rev. H. M. STEPHENSON, M.A. 5s.
- BOOKS XXI. AND XXII. Edited by the Rev. W. W. CAPES, M.A. With Maps. 5s.
- BOOKS XXIII. AND XXIV. Edited by G. C. MACAULAY, M.A. With Maps. 5s.
- THE LAST TWO KINGS OF MACEDON. EXTRACTS FROM THE FOURTH AND FIFTH DECADES OF LIVY. Selected and Edited, with Introduction and Notes, by F. H. RAWLINS, M.A., Fellow of King's College, Cambridge; and Assistant-Master at Eton. With Maps. 3s. 6d.
- THE SUBJUGATION OF ITALY. SELECTIONS FROM THE FIRST DECADE. Edited by G. E. MARINDIN, M.A., formerly Assistant Master at Eton. [*In preparation.*]
- Lucretius.** BOOKS I.—III. Edited by J. H. WARBURTON LEE, M.A., late Scholar of Corpus Christi College, Oxford, and Assistant-Master at Rossall. 4s. 6d.
- Lysias.**—SELECT ORATIONS. Edited by E. S. SHUCKBURGH, M.A., late Assistant-Master at Eton College, formerly Fellow and Assistant-Tutor of Emmanuel College, Cambridge. New Edition, revised. 6s.

- Martial.**—SELECT EPIGRAMS. Edited by Rev. H. M. STEPHENSON, M.A. New Edition, Revised and Enlarged. 6s. 6d.
- Ovid.**—FASTI. Edited by G. H. HALLAM, M.A., Fellow of St. John's College, Cambridge, and Assistant-Master at Harrow. With Maps. 5s.
- HEROIDUM EPISTULÆ XIII. Edited by E. S. SHUCKBURGH, M.A. 4s. 6d.
- TRISTIA. Edited by the same. [In preparation.]
- METAMORPHOSES, BOOKS I.—III. Edited by C. SIMMONS, M.A. [In preparation.]
- METAMORPHOSES. BOOKS XIII. AND XIV. Edited by C. SIMMONS, M.A. 4s. 6d.
- Plato.**—LACHES. Edited, with Introduction and Notes, by M. T. TATHAM, M.A., formerly Assistant Master at Westminster. 2s. 6d.
- THE REPUBLIC. BOOKS I.—V. Edited by T. H. WARREN, M.A., President of St. Mary Magdalen College, Oxford. 6s.
- Plautus.**—MILES GLORIOSUS. Edited by R. Y. TYRRELL, M.A., Fellow of Trinity College, and Regius Professor of Greek in the University of Dublin. Second Edition Revised. 5s.
- AMPHITRUO. Edited by ARTHUR PALMER, M.A., Fellow of Trinity College and Regius Professor of Latin in the University of Dublin. [In the press.]
- Pliny.**—LETTERS. BOOK III. Edited by Professor JOHN E. B. MAYOR. With Life of Pliny by G. H. RENDALL, M.A. 5s.
- LETTERS. BOOKS I. and II. Edited by J. COWAN, B.A., Assistant-Master in the Grammar School, Manchester. [In the press.]
- Plutarch.**—LIFE OF THEMISTOKLES. Edited by Rev. H. A. HOLDEN, M.A., LL.D. 5s.
- LIVES OF GALBA AND OTHO. Edited by E. G. HARDY, M.A. [In the press.]
- Polybius.**—THE HISTORY OF THE ACHÆAN LEAGUE AS CONTAINED IN THE REMAINS OF POLYBIUS. Edited by W. W. CAPES, M.A. 6s. 6d.
- Propertius.**—SELECT POEMS. Edited by Professor J. P. POSTGATE, M.A., Fellow of Trinity College, Cambridge. Second Edition, revised. 6s.
- Sallust.**—CATILINA AND JUGURTHA. Edited by C. MERIVALE, D.D., Dean of Ely. New Edition; carefully revised and enlarged, 4s. 6d. Or separately, 2s. 6d. each.
- BELLUM CATULINÆ. Edited by A. M. COOK, M.A., Assistant Master at St. Paul's School. 4s. 6d.
- JUGURTHA. By the same Editor. [In preparation.]
- Tacitus.**—AGRICOLA AND GERMANIA. Edited by A. J. CHURCH, M.A., and W. J. BRODRIBB, M.A., Translators of Tacitus. New Edition, 3s. 6d. Or separately, 2s. each.
- THE ANNALS. BOOK VI. By the same Editors. 2s. 6d.
- THE HISTORIES. BOOKS I. AND II. Edited by A. D. GODLEY, M.A. 5s.

- Tacitus.**—THE HISTORIES. BOOKS III.—V. By the same Editor. [In the press.]
- THE ANNALS. BOOKS I. AND II. Edited by J. S. REID, M.L., Litt.D. [In preparation.]
- Terence.**—HAUTON TIMORUMENOS. Edited by E. S. SHUCKBURGH, M.A. 3s. With Translation, 4s. 6d.
- PHORMIO. Edited by Rev. JOHN BOND, M.A., and A. S. WALPOLE, M.A. 4s. 6d.
- Thucydides.** BOOK IV. Edited by C. E. GRAVES, M.A., Classical Lecturer, and late Fellow of St. John's College, Cambridge. 5s.
- BOOK V. By the same Editor. [In the press.]
- BOOKS I., II., AND III. Edited by C. BRYANS, M.A. [In preparation.]
- BOOKS VI. AND VII. THE SICILIAN EXPEDITION. Edited by the Rev. PERCIVAL FROST, M.A., late Fellow of St. John's College, Cambridge. New Edition, revised and enlarged, with Map. 5s.
- Tibullus.**—SELECT POEMS. Edited by Professor J. P. POSTGATE, M.A. [In preparation.]
- Virgil.**—ÆNEID. BOOKS II. AND III. THE NARRATIVE OF ÆNEAS. Edited by E. W. HOWSON, M.A., Fellow of King's College, Cambridge, and Assistant-Master at Harrow. 3s. 7d.
- Xenophon.**—HELLENICA, BOOKS I. AND II. Edited by H. HAILSTONE, B.A., late Scholar of Peterhouse, Cambridge. With Map. 4s. 6d.
- CYROPÆDIA. BOOKS VII. AND VIII. Edited by ALFRED GOODWIN, M.A., Professor of Greek in University College, London. 5s.
- MEMORABILIA SOCRATIS. Edited by A. R. CLUER, B.A., Balliol College, Oxford. 6s.
- THE ANABASIS. BOOKS I.—IV. Edited by Professors W. W. GOODWIN and J. W. WHITE. Adapted to Goodwin's Greek Grammar. With a Map. 5s.
- HERO. With Introduction, Summaries, Critical and Explanatory Notes and Indices, and Critical Appendix. Edited by Rev. H. A. HOLDEN, M.A., LL.D. Third Edition; revised: 3s. 6d.
- OECONOMICUS. By the same Editor. With Introduction, Explanatory Notes, Critical Appendix, and Lexicon. Fourth Edition. 6s.

*\*\* Other Volumes will follow.*

---

## CLASSICAL LIBRARY.

(1) Texts, Edited with Introductions and Notes, for the use of Advanced Students. (2) Commentaries and Translations.

- Æschylus.**—THE EUMENIDES. The Greek Text, with Introduction, English Notes, and Verse Translation. By BERNARD DRAKE, M.A., late Fellow of King's College, Cambridge. 8vo. 5s.
- AGAMEMNON. Edited, with Introduction and Notes, by A. W. VERRALL, Litt.D. 8vo. [*In the press.*]
- AGAMEMNON, CHOEPHORÆ, AND EUMENIDES. Edited, with Introduction and Notes, by A. O. PRICKARD, M.A., Fellow and Tutor of New College, Oxford. 8vo. [*In preparation.*]
- THE "SEVEN AGAINST THEBES." Edited, with Introduction, Commentary, and Translation, by A. W. VERRALL, Litt.D., Fellow of Trinity College, Cambridge. 8vo. 7s. 6d.
- THE SUPPLICES. A Revised Text, with Introduction, Critical Notes, Commentary and Translation. By T. G. TUCKER, M.A., Fellow of St. John's College, Cambridge, and Professor of Classical Philology in the University of Melbourne. 8vo. [*In the press.*]
- Antoninus, Marcus Aurelius.**—BOOK IV. OF THE MEDITATIONS. The Text Revised, with Translation and Notes, by HASTINGS CROSSLEY, M.A., Professor of Greek in Queen's College, Belfast. 8vo. 6s.
- Aristotle.**—THE METAPHYSICS. BOOK I. Translated by a Cambridge Graduate. 8vo. 5s.
- THE POLITICS. Edited, after SUSEMIHL, by R. D. HICKS, M.A., Fellow of Trinity College, Cambridge. 8vo. [*In the press.*]
- THE POLITICS. Translated, with Analysis and Critical Notes, by Rev. J. E. C. WELLDON, M.A., Fellow of King's College, Cambridge, and Head-Master of Harrow School. Second Edition, revised. Crown 8vo. 10s. 6d.
- THE RHETORIC. Translated, with an Analysis and Critical Notes, by the same. Crown 8vo. 7s. 6d.
- THE ETHICS. Translated, with an Analysis and Critical Notes, by the same. Crown 8vo. [*In preparation.*]
- AN INTRODUCTION TO ARISTOTLE'S RHETORIC. With Analysis, Notes, and Appendices. By E. M. COPE, Fellow and Tutor of Trinity College, Cambridge. 8vo. 14s.
- THE SOPHISTICI ELENCHI. With Translation and Notes by E. POSTE, M.A., Fellow of Oriel College, Oxford. 8vo. 8s. 6d.
- Aristophanes.**—THE BIRDS. Translated into English Verse, with Introduction, Notes, and Appendices, by B. H. KENNEDY, D.D., Regius Professor of Greek in the University of Cambridge. Crown 8vo. 6s. Help Notes to the same, for the use of Students, 1s. 6d.
- Attic Orators.**—FROM ANTIPHON TO ISAEOS. By R. C. JEBB, Litt.D., LL.D., Professor of Greek in the University of Cambridge. 2 vols. 8vo. 25s.

- Babrius.**—Edited, with Introductory Dissertations, Critical Notes, Commentary and Lexicon. By Rev. W. GUNION RUTHERFORD, M.A., LL.D., Head-Master of Westminster. 8vo. 12s. 6d.
- Catullus.**—SELECT POEMS. With Commentary Illustrative of Roman Social Life. By W. M. RAMSAY, M.A., Professor of Latin in the University of Aberdeen. [*In preparation.*]
- Cicero.**—THE ACADEMICA. The Text revised and explained by J. S. REID, M.L., Litt.D., Fellow of Caius College, Cambridge. 8vo. 15s.
- THE ACADEMICS. Translated by J. S. REID, M.L., Litt.D. 8vo. 5s. 6d.
- SELECT LETTERS. After the Edition of ALBERT WATSON, M.A. Translated by G. E. JEANS, M.A., Fellow of Hertford College, Oxford, and late Assistant-Master at Haileybury. Second Edition. Revised. Crown 8vo. 10s. 6d.  
(See also *Classical Series.*)
- Euripides.**—MEDEA. Edited, with Introduction and Notes, by A. W. VERRALL, Litt.D. 8vo. 7s. 6d.
- IPHIGENIA IN AULIS. Edited, with Introduction and Notes, by E. B. ENGLAND, M.A. 8vo. [*In preparation.*]
- INTRODUCTION TO THE STUDY OF EURIPIDES. By Professor J. P. MAHAFFY. Fcap. 8vo. 1s. 6d. (*Classical Writers.*)  
(See also *Classical Series.*)
- Herodotus.**—BOOKS I.—III. THE ANCIENT EMPIRES OF THE EAST. Edited, with Notes, Introductions, and Appendices, by A. H. SAYCE, Deputy-Professor of Comparative Philology, Oxford; Honorary LL.D., Dublin. Demy 8vo. 16s.
- BOOKS IV.—IX. Edited by REGINALD W. MACAN, M.A., Lecturer in Ancient History at Brasenose College, Oxford. 8vo. [*In preparation.*]
- HERODOTUS. Translated with Introduction, Notes and Indices, by G. C. MACAULAY, M.A., formerly Fellow of Trinity College, Cambridge, and Assistant Master at Rugby. 2 vols. Crown 8vo. [*In the press.*]
- Homer.**—THE ILIAD. Edited, with Introduction and English Notes, by WALTER LEAF, Litt.D., late Fellow of Trinity College, Cambridge. 8vo. In Two Volumes. Vol. I. Books I.—XII. 14s. Vol. II. Books XIII.—XIV. 14s.
- THE ILIAD. Translated into English Prose. By ANDREW LANG, M.A., WALTER LEAF, Litt.D., and ERNEST MYERS, M.A. Crown 8vo. 12s. 6d.
- THE ODYSSEY. Done into English by S. H. BUTCHER, M.A., Professor of Greek in the University of Edinburgh, and ANDREW LANG, M.A., late Fellow of Merton College, Oxford. Seventh and Cheaper Edition, revised and corrected. Crown 8vo. 6s.
- INTRODUCTION TO THE STUDY OF HOMER. By the Right Hon. W. E. GLADSTONE, M.P. 18mo. 1s. (*Literature Primers.*)

**Homer.**—HOMERIC DICTIONARY. For Use in Schools and Colleges. Translated from the German of Dr. G. AUTENRIETH, with Additions and Corrections, by R. P. KEEP, Ph.D. With numerous Illustrations. Crown 8vo. 6s.

(See also *Classical Series*.)

**Horace.**—THE WORKS OF HORACE RENDERED INTO ENGLISH PROSE. With Introductions, Running Analysis, Notes, &c. By J. LONSDALE, M.A., and S. LEE, M.A. (*Globe Edition*.) 3s. 6d.

**STUDIES, LITERARY AND HISTORICAL, IN THE ODES OF HORACE.** By A. W. VERRALL, Litt.D., Fellow of College, Cambridge. Demy 8vo. 8s. 6d.

(See also *Classical Series*.)

**Juvenal.**—THIRTEEN SATIRES OF JUVENAL. With a Commentary. By JOHN E. B. MAYOR, M.A., Professor of Latin in the University of Cambridge. Crown 8vo.

\* \* Vol. I. Fourth Edition, Revised and Enlarged. 10s. 6d.  
Vol. II. Second Edition. 10s. 6d.

\* \* The new matter consists of an Introduction (pp. 1—53), Additional Notes (pp. 333—466) and Index (pp. 467—526). It is also issued separately, as a Supplement to the previous edition, at 5s.

**THIRTEEN SATIRES.** Translated into English after the Text of J. E. B. MAYOR by ALEXANDER LEEPER, M.A., Warden of Trinity College, in the University of Melbourne. Crown 8vo. 3s. 6d.

(See also *Classical Series*.)

**Ktesias.**—THE FRAGMENTS OF THE PERSIKA OF KTESIAS. Edited with Introduction and Notes by JOHN GILMORE, M.A. 8vo. 8s. 6d.

**Livy.**—BOOKS I.—IV. Translated by Rev. H. M. STEPHENSON, M.A., late Head-Master of St. Peter's School, York.

[*In preparation*.]

**BOOKS XXI.—XXV.** Translated by ALFRED JOHN CHURCH, M.A., of Lincoln College, Oxford, Professor of Latin, University College, London, and WILLIAM JACKSON BRODRIBB, M.A., late Fellow of St. John's College, Cambridge. Cr. 8vo. 7s. 6d.

**INTRODUCTION TO THE STUDY OF LIVY.** By Rev. W. W. CAPES, Reader in Ancient History at Oxford. Fcap. 8vo. 1s. 6d. (*Classical Writers Series*.)

(See also *Classical Series*.)

**Martial.**—BOOKS I. AND II. OF THE EPIGRAMS. Edited, with Introduction and Notes, by Professor J. E. B. MAYOR, M.A. 8vo.

[*In the press*.]

(See also *Classical Series*.)

**Pausanias.**—DESCRIPTION OF GREECE. Translated by J. G. FRAZER, M.A., Fellow of Trinity College, Cambridge.

[*In preparation*.]

- Phrynichus.**—THE NEW PHRYNICHUS; being a Revised Text of the Ecloga of the Grammariān Phrynichus. With Introduction and Commentary by Rev. W. GUNION RUTHERFORD, M.A., LL.D., Head-Master of Westminster. 8vo. 18s.
- Pindar.**—THE EXTANT ODES OF PINDAR. Translated into English, with an Introduction and short Notes, by ERNEST MYERS, M.A., late Fellow of Wadham College, Oxford. Second Edition. Crown 8vo. 5s.
- THE OLYMPIAN AND PYTHIAN ODES. Edited, with an Introductory Essay, Notes, and Indexes, by BASIL GILDERSLEEVE, Professor of Greek in the Johns Hopkins University, Baltimore. Crown 8vo. 7s. 6d.
- Plato.**—PHÆDO. Edited, with Introduction, Notes, and Appendices, by R. D. ARCHER-HIND, M.A., Fellow of Trinity College, Cambridge. 8vo. 8s. 6d.
- TIMAEUS.—Edited, with Introduction, Notes, and a Translation, by the same Editor. 8vo. 16s.
- PHÆDO. Edited, with Introduction and Notes, by W. D. GEDDES, LL.D., Principal of the University of Aberdeen. Second Edition. Demy 8vo. 8s. 6d.
- THE REPUBLIC OF PLATO. Translated into English, with an Analysis and Notes, by J. LL. DAVIES, M.A., and D. J. VAUGHAN, M.A. 18mo. 4s. 6d.
- EUTHYPHRO, APOLOGY, CRITO, AND PHÆDO. Translated by F. J. CHURCH. 18mo. 4s. 6d.
- PHÆDRUS, LYSIS, AND PROTAGORAS. A New and Literal Translation, mainly from the text of Bekker. By J. WRIGHT, M.A., Trinity College, Cambridge. 18mo. 4s. 6d.
- (See also *Classical Series*.)
- Plautus.**—THE MOSTELLARIA OF PLAUTUS. With Notes, Prolegomena, and Excursus. By WILLIAM RAMSAY, M.A., formerly Professor of Humanity in the University of Glasgow. Edited by Professor GEORGE G. RAMSAY, M.A., of the University of Glasgow. 8vo. 14s.
- (See also *Classical Series*.)
- Pliny.**—CORRESPONDENCE WITH TRAJAN. C. Plinii Caecilii Secundi Epistulae ad Traianum Imperatorem cum Eiusdem Responsis. Edited, with Notes and Introductory Essays, by E. G. HARDY, M.A., Fellow of Jesus College, Oxford, and formerly Head Master of Grantham School. 8vo. 10s. 6d.
- Polybius.**—THE HISTORIES OF POLYBIUS. Translated from the Text of F. HULTSCH by E. S. SHUCKBURGH, M.A., late Fellow of Emmanuel College, Cambridge. 2 vols. Crown 8vo. 24s.
- Sallust.**—CATILINE AND JUGURTHA. Translated, with Introductory Essays, by A. W. POLLARD, B.A. Crown 8vo. 6s.
- THE CATILINE (separately). Crown 8vo. 3s.
- (See also *Classical Series*.)

- Sophocles.**—**ŒDIPUS THE KING.** Translated from the Greek of Sophocles into English Verse by E. D. A. MORSHEAD, M.A., late Fellow of New College, Oxford; Assistant Master at Winchester College. Fcap. 8vo. 3s. 6d.
- Tacitus.**—**THE ANNALS.** Edited, with Introductions and Notes, by G. O. HOLBROOKE, M.A., Professor of Latin in Trinity College, Hartford, U.S.A. With Maps. 8vo. 16s.
- THE ANNALS.** Translated by A. J. CHURCH, M.A., and W. J. BRODRIBB, M.A. With Notes and Maps. New Edition, Crown 8vo. 7s. 6d.
- THE HISTORIES.** Edited, with Introduction and Notes, by Rev. W. A. SPOONER, M.A., Fellow of New College, and H. M. SPOONER, M.A., formerly Fellow of Magdalen College, Oxford. 8vo. *[In the press.]*
- THE HISTORY.** Translated by A. J. CHURCH, M.A., and W. J. BRODRIBB, M.A. With Notes and a Map. Crown 8vo. 6s.
- THE AGRICOLA AND GERMANY, WITH THE DIALOGUE ON ORATORY.** Translated by A. J. CHURCH, M.A., and W. J. BRODRIBB, M.A. With Notes and Maps. New and Revised Edition. Crown 8vo. 4s. 6d.
- INTRODUCTION TO THE STUDY OF TACITUS.** By A. J. CHURCH, M.A. and W. J. BRODRIBB, M.A. Fcap. 8vo. 1s. 6d. (*Classical Writers Series.*)

**Theocritus, Bion, and Moschus.** Rendered into English Prose, with Introductory Essay, by A. LANG, M.A. 18mo. 4s. 6d.  
\* \* Also an Edition on Large Paper. Crown 8vo. 9s.

**Thucydides.**—**BOOK VIII.** Edited with Introduction and Notes, by H. C. GOODHART, M.A., Fellow of Trinity College, Cambridge. *[In preparation.]*

**Virgil.**—**THE WORKS OF VIRGIL RENDERED INTO ENGLISH PROSE,** with Notes, Introductions, Running Analysis, and an Index, by JAMES LONSDALE, M.A., and SAMUEL LEE, M.A. New Edition. Globe 8vo. 3s. 6d.

**THE ÆNEID.** Translated by J. W. MACKAIL, M.A., Fellow of Balliol College, Oxford. Crown 8vo. 7s. 6d.

**Xenophon.**—**COMPLETE WORKS.** Translated, with Introduction and Essays, by H. G. DAKYNS, M.A., Assistant-Master in Clifton College. Four Volumes. Crown 8vo. *[In the press]*

## GRAMMAR, COMPOSITION, & PHILOLOGY.

**Belcher.**—**SHORT EXERCISES IN LATIN PROSE COMPOSITION AND EXAMINATION PAPERS IN LATIN GRAMMAR,** to which is prefixed a Chapter on Analysis of Sentences. By the Rev. H. BELCHER, M.A., Rector of the High School, Dunedin, N.Z. New Edition. 18mo. 1s. 6d.

**KEY TO THE ABOVE** (for Teachers only). 3s. 6d.



- Belcher.**—SHORT EXERCISES IN LATIN PROSE COMPOSITION. Part II., On the Syntax of Sentences, with an Appendix, including EXERCISES IN LATIN IDIOMS, &c. 18mo. 2s.
- KEY TO THE ABOVE (for Teachers only). 3s.
- Blackie.**—GREEK AND ENGLISH DIALOGUES FOR USE IN SCHOOLS AND COLLEGES. By JOHN STUART BLACKIE, Emeritus Professor of Greek in the University of Edinburgh. New Edition. Fcap. 8vo. 2s. 6d.
- Bryans.**—LATIN PROSE EXERCISES BASED UPON CAESAR'S GALLIC WAR. With a Classification of Cæsar's Chief Phrases and Grammatical Notes on Cæsar's Usages. By CLEMENT BRYANS, M.A., Assistant-Master in Dulwich College. Second Edition, Revised and Enlarged. Extra fcap. 8vo. 2s. 6d.
- KEY TO THE ABOVE (for Teachers only). New Edition. 4s. 6d.
- GREEK PROSE EXERCISES based upon Thucydides. By the same Author. Extra fcap. 8vo. [*In preparation.*]
- Cookson.**—A LATIN SYNTAX. By CHRISTOPHER COOKSON, M.A., Assistant-Master at St. Paul's School. 8vo. [*In preparation.*]
- Cornell University Studies in Classical Philology.**  
 Edited by ISAAC FLAGG, WILLIAM GARDNER HALE, and BENJAMIN IDE WHEELER. I. The CUM-Constructio: their History and Functions. Part I, Critical. 1s. 8d. nett. Part 2, Constructive. By WILLIAM GARDNER HALE. 3s. 4d. nett. II. Analogy and the Scope of its Application in Language. By BENJAMIN IDE WHEELER. 1s. 3d. nett.
- Eicke.**—FIRST LESSONS IN LATIN. By K. M. EICKE, B.A., Assistant-Master in Oundle School. Globe 8vo. 2s.
- England.**—EXERCISES ON LATIN SYNTAX AND IDIOM. ARRANGED WITH REFERENCE TO ROBY'S SCHOOL LATIN GRAMMAR. By E. B. ENGLAND, M.A., Assistant Lecturer at the Owens College, Manchester. Crown 8vo. 2s. 6d.  
 Key for Teachers only, 2s. 6d.
- Giles.**—A MANUAL OF GREEK AND LATIN PHILOLOGY. By P. GILES, M.A., Fellow of Gonville and Caius College, Cambridge. Crown 8vo. [*In preparation.*]
- Goodwin.**—Works by W. W. GOODWIN, LL.D., Professor of Greek in Harvard University, U.S.A.  
 SYNTAX OF THE MOODS AND TENSES OF THE GREEK VERB. New Edition, Revised and Enlarged. 8vo. [*In the press.*]  
 A GREEK GRAMMAR. New Edition, revised. Crown 8vo. 6s.  
 "It is the best Greek Grammar of its size in the English language."
- ATHENÆUM.**  
 A GREEK GRAMMAR FOR SCHOOLS. Crown 8vo. 3s. 6d.
- Greenwood.**—THE ELEMENTS OF GREEK GRAMMAR, including Accidence, Irregular Verbs, and Principles of Derivation and Composition, adapted to the System of Crude Forms. By J. G. GREENWOOD, Principal of Owens College, Manchester. New Edition. Crown 8vo. 5s. 6d.

- Hadley and Allen.**—A GREEK GRAMMAR FOR SCHOOLS AND COLLEGES. By JAMES HADLEY, late Professor in Yale College. Revised and in part Rewritten by FREDERIC DE FOREST ALLEN, Professor in Harvard College. Crown 8vo. 6s.
- Hodgson.**—MYTHOLOGY FOR LATIN VERSIFICATION. A brief Sketch of the Fables of the Ancients, prepared to be rendered into Latin Verse for Schools. By F. HODGSON, B.D., late Provost of Eton. New Edition, revised by F. C. HODGSON, M.A. 18mo. 3s.
- Jackson.**—FIRST STEPS TO GREEK PROSE COMPOSITION. By BLOMFIELD JACKSON, M.A., Assistant-Master in King's College School, London. New Edition, revised and enlarged. 18mo. 1s. 6d.
- KEY TO FIRST STEPS (for Teachers only). 18mo. 3s. 6d.
- SECOND STEPS TO GREEK PROSE COMPOSITION, with Miscellaneous Idioms, Aids to Accentuation, and Examination Papers in Greek Scholarship. 18mo. 2s. 6d.
- KEY TO SECOND STEPS (for Teachers only). 18mo. 3s. 6d.
- Kynaston.**—EXERCISES IN THE COMPOSITION OF GREEK IAMBIC VERSE by Translations from English Dramatists. By Rev. H. KYNASTON, D.D., Principal of Cheltenham College. With Introduction, Vocabulary, &c. New Edition, revised and enlarged. Extra fcap. 8vo. 5s.
- KEY TO THE SAME (for Teachers only). Extra fcap. 8vo. 4s. 6d.
- Lupton.**—Works by J. H. LUPTON, M.A., Sur-Master of St. Paul's School, and formerly Fellow of St. John's College, Cambridge.
- AN INTRODUCTION TO LATIN ELEGIAC VERSE COMPOSITION. Globe 8vo. 2s. 6d.
- LATIN RENDERING OF THE EXERCISES IN PART II. (XXV.-C.). Globe 8vo. 3s. 6d.
- AN INTRODUCTION TO LATIN LYRIC VERSE COMPOSITION. Globe 8vo. 3s.
- KEY FOR THE USE OF TEACHERS ONLY. Globe 8vo. 4s. 6d.
- Mackie.**—PARALLEL PASSAGES FOR TRANSLATION INTO GREEK AND ENGLISH. Carefully graduated for the use of Colleges and Schools. With Indexes. By Rev. ELLIS C. MACKIE, Classical Master at Heversham Grammar School. Globe 8vo. 4s. 6d.
- Macmillan.**—FIRST LATIN GRAMMAR. By M. C. MACMILLAN, M.A., late Scholar of Christ's College, Cambridge, sometime Assistant-Master in St. Paul's School. New Edition, enlarged. Fcap. 8vo. 1s. 6d.
- Macmillan's Greek Course.**—Edited by Rev. W. GARNON RUTHERFORD, M.A., LL.D., Head Master of Westminster.
- I.—FIRST GREEK GRAMMAR. By the Editor. New Edition, thoroughly revised. Globe 8vo. 2s.

- Macmillan's Greek Course.**—II.—EASY EXERCISES IN GREEK ACCIDENCE. By H. G. UNDERHILL, M.A., Assistant-Master St. Paul's Preparatory School. Globe 8vo. 3s.
- III.—SECOND GREEK EXERCISE BOOK. By Rev. W. HEARD. *[In preparation.]*
- IV.—MANUAL OF GREEK ACCIDENCE. By the Editor. *[In preparation.]*
- V.—MANUAL OF GREEK SYNTAX. By the Editor. *[In preparation.]*
- VI.—ELEMENTARY GREEK COMPOSITION. By the Editor. *[In preparation.]*
- Macmillan's Greek Reader.**—STORIES AND LEGENDS. A First Greek Reader, with Notes, Vocabulary, and Exercises. By F. H. COLSON, M.A., late Fellow of St. John's College, Cambridge; Head Master of Plymouth College. Globe 8vo. 3s.
- Macmillan's Latin Course.** FIRST YEAR. By A. M. COOK, M.A., Assistant-Master at St. Paul's School. New Edition, revised and enlarged. Globe 8vo. 3s. 6d. Part II. *[In the press.]*
- Macmillan's Latin Reader.**—A LATIN READER FOR THE LOWER FORMS IN SCHOOLS. By H. J. HARDY, M.A., Assistant Master in Winchester College. Globe 8vo. 2s. 6d.
- Macmillan's Shorter Latin Course.** By A. M. COOK, M.A., Assistant-Master at St. Paul's School. Being an abridgment of "Macmillan's Latin Course," First Year. Globe 8vo. 1s. 6d.
- Marshall.**—A TABLE OF IRREGULAR GREEK VERBS. Classified according to the arrangement of Curtius's Greek Grammar. By J. M. MARSHALL, M.A., Head Master of the Grammar School, Durham. New Edition. 8vo. 1s.
- Mayor (John E. B.)**—FIRST GREEK READER. Edited after KARL HALM, with Corrections and large Additions by Professor JOHN E. B. MAYOR, M.A., Fellow of St. John's College, Cambridge. New Edition, revised. Fcap. 8vo. 4s. 6d.
- Mayor (Joseph B.)**—GREEK FOR BEGINNERS. By the Rev. J. B. MAYOR, M.A., Professor of Classical Literature in King's College, London. Part I., with Vocabulary, 1s. 6d. Parts II. and III., with Vocabulary and Index, 3s. 6d. Complete in one Vol. fcap. 8vo. 4s. 6d.
- Nixon.**—PARALLEL EXTRACTS, Arranged for Translation into English and Latin, with Notes on Idioms. By J. E. NIXON, M.A., Fellow and Classical Lecturer, King's College, Cambridge. Part I.—Historical and Epistolary. New Edition, revised and enlarged. Crown 8vo. 3s. 6d.
- PROSE EXTRACTS, Arranged for Translation into English and Latin, with General and Special Prefaces on Style and Idiom. I. Oratorical. II. Historical. III. Philo-sophical and Miscellaneous. By the same Author. Crown 8vo. 3s. 6d.
- \* \* \* *Translations of Select Passages supplied by Author only.*

**Peile.**—A PRIMER OF PHILOLOGY. By J. PEILE, Litt.D.,  
Master of Christ's College, Cambridge. 18mo. 1s.

**Postgate.**—SERMO LATINUS. A Short Guide to Latin  
Prose Composition. Part I. Introduction. Part II. Selected  
Passages for Translation. By J. P. POSTGATE, M.A., Litt. D.,  
Fellow and Classical Lecturer of Trinity College, Cambridge,  
Professor of Comparative Philology in University College, London.  
Globe 8vo. 2s. 6d.

KEY to "Selected Passages." 3s. 6d.

**Postgate and Vince.**—A DICTIONARY OF LATIN  
ETYMOLOGY. By J. P. POSTGATE, M.A., and C. A. VINCE,  
M.A. [*In preparation.*]

**Potts (A. W.)**—Works by ALEXANDER W. POTTS, M.A.,  
LL.D., late Fellow of St. John's College, Cambridge; Head  
Master of the Fettes College, Edinburgh.

HINTS TOWARDS LATIN PROSE COMPOSITION. New  
Edition. Extra fcap. 8vo. 3s.

PASSAGES FOR TRANSLATION INTO LATIN PROSE.  
Edited with Notes and References to the above. New Edition.  
Extra fcap. 8vo. 2s. 6d.

LATIN VERSIONS OF PASSAGES FOR TRANSLATION  
INTO LATIN PROSE (for Teachers only). 2s. 6d.

**Preston.**—EXERCISES IN LATIN VERSE OF VARIOUS  
KINDS. By Rev. G. PRESTON, M.A., late Fellow of Magdalene  
College, Cambridge, and Head Master of the King's School,  
Chester. Globe 8vo. 2s. 6d.

KEY, for the use of Teachers only. Globe 8vo. 5s.

**Reid.**—A GRAMMAR OF TACITUS. By J. S. REID, M.L.,  
Fellow of Caius College, Cambridge. [*In preparation.*]

A GRAMMAR OF VERGIL. By the same Author. [*In preparation.*]

\* \* *Similar Grammars to other Classical Authors will probably follow.*

**Roby.**—A GRAMMAR OF THE LATIN LANGUAGE, from  
Plautus to Suetonius. By H. J. ROBY, M.A., late Fellow of St.  
John's College, Cambridge. In Two Parts. Part I. Fifth  
Edition, containing:—Book I. Sounds. Book II. Inflexions.  
Book III. Word-formation. Appendices. Crown 8vo. 9s.

Part II. Syntax, Prepositions, &c. Crown 8vo. 10s. 6d.

"Marked by the clear and practised insight of a master in his art. A book that  
would do honour to any country."—ATHENÆUM.

SCHOOL LATIN GRAMMAR. By the same Author. Cr. 8vo. 5s.

**Rush.**—SYNTHETIC LATIN DELECTUS. A First Latin  
Construing Book arranged on the Principles of Grammatical  
Analysis. With Notes and Vocabulary. By E. RUSH, B.A.  
With Preface by the Rev. W. F. MOULTON, M.A., D.D. New  
and Enlarged Edition. Extra fcap. 8vo. 2s. 6d.

**Rust.**—FIRST STEPS TO LATIN PROSE COMPOSITION.  
By the Rev. G. RUST, M.A., of Pembroke Coll., Oxford, Master  
of the Lower School, King's Coll., London. New Ed. 18mo. 1s. 6d.

**Rust.**—KEY TO THE ABOVE. By W. M. YATES, Assistant-Master in the High School, Sale. 18mo. 3s. 6d.

**Rutherford.**—Works by the Rev. W. GUNION RUTHERFORD, M.A., LL.D., Head-Master of Westminster.

REX LEX. A Short Digest of the principal Relations between Latin, Greek, and Anglo-Saxon Sounds. 8vo. [*In preparation.*]

THE NEW PHRYNICHUS; being a Revised Text of the Ecloga of the Grammarian Phrynichus. With Introduction and Commentary. 8vo. 18s. (See also Macmillan's Greek Course.)

**Shuckburgh.**—PASSAGES FROM LATIN AUTHORS FOR TRANSLATION INTO ENGLISH. Selected with a view to the needs of Candidates for the Cambridge Previous, Local, and Schools' Examinations. By E. S. SHUCKBURGH, M.A., Emmanuel College, Cambridge. Crown 8vo. 2s.

**Simpson.**—LATIN PROSE AFTER THE BEST AUTHORS. By F. P. SIMPSON, B.A., late Scholar of Balliol College, Oxford. Part I. CÆSARIAN PROSE. Extra fcap. 8vo. 2s. 6d.

KEY TO THE ABOVE, for Teachers only. Extra fcap. 8vo. 5s.

**Strachan and Wilkins.**—ANALECTA. Passages for Translation. Selected by JOHN S. STRACHAN, M.A., Pembroke College, Cambridge, and A. S. WILKINS, Litt.D., LL.D., Fellow of St. John's College, Cambridge, Professors in Owens College, Manchester. Crown 8vo. 5s.

**Thring.**—Works by the Rev. E. THRING, M.A., late Head-Master of Uppingham School.

A LATIN GRADUAL. A First Latin Construing Book for Beginners. New Edition, enlarged, with Coloured Sentence Maps. Fcap. 8vo. 2s. 6d.

A MANUAL OF MOOD CONSTRUCTIONS. Fcap. 8vo. 1s. 6d.

**Welch and Duffield.**—LATIN ACCIDENCE AND EXERCISES ARRANGED FOR BEGINNERS. By WILLIAM WELCH, M.A., and C. G. DUFFIELD, M.A., Assistant Masters at Cranleigh School. 18mo. 1s. 6d.

This book is intended as an introduction to Macmillan's *Elementary Classics*, and is the development of a plan which has been in use for some time and has been worked satisfactorily.

**White.**—FIRST LESSONS IN GREEK. Adapted to GOODWIN'S GREEK GRAMMAR, and designed as an introduction to the ANABASIS OF XENOPHON. By JOHN WILLIAMS WHITE, Ph.D., Assistant-Professor of Greek in Harvard University. Crown 8vo. 4s. 6d.

**Wright.**—Works by J. WRIGHT, M.A., late Head Master of Sutton Coldfield School.

A HELP TO LATIN GRAMMAR; or, The Form and Use of Words in Latin, with Progressive Exercises. Crown 8vo. 4s. 6d.

THE SEVEN KINGS OF ROME. An Easy Narrative, abridged from the First Book of Livy by the omission of Difficult Passages; being a First Latin Reading Book, with Grammatical Notes and Vocabulary. New and revised Edition. Fcap. 8vo. 3s. 6d.

**Wright.**—FIRST LATIN STEPS; OR, AN INTRODUCTION BY A SERIES OF EXAMPLES TO THE STUDY OF THE LATIN LANGUAGE. Crown 8vo. 3s.

ATTIC PRIMER. Arranged for the Use of Beginners. Extra fcap. 8vo. 2s. 6d.

A COMPLETE LATIN COURSE, comprising Rules with Examples, Exercises, both Latin and English, on each Rule, and Vocabularies. Crown 8vo. 2s. 6d.

## ANTIQUITIES, ANCIENT HISTORY, AND PHILOSOPHY.

**Arnold.**—Works by W. T. ARNOLD, M.A.

A HANDBOOK OF LATIN EPIGRAPHY. [*In preparation.*]

THE ROMAN SYSTEM OF PROVINCIAL ADMINISTRATION TO THE ACCESSION OF CONSTANTINE THE GREAT. Crown 8vo. 6s.

**Arnold (T.)**—THE SECOND PUNIC WAR. Being Chapters on THE HISTORY OF ROME. By the late THOMAS ARNOLD, D.D., formerly Head Master of Rugby School, and Regius Professor of Modern History in the University of Oxford. Edited, with Notes, by W. T. ARNOLD, M.A. With 8 Maps. Crown 8vo. 8s. 6d.

**Beesly.**—STORIES FROM THE HISTORY OF ROME. By Mrs. BEESLY. Fcap. 8vo. 2s. 6d.

**Burn.**—ROMAN LITERATURE IN RELATION TO ROMAN ART. By Rev. ROBERT BURN, M.A., Fellow of Trinity College, Cambridge. With numerous Illustrations. Extra Crown 8vo. 14s.

**Bury.**—A HISTORY OF THE LATER ROMAN EMPIRE FROM ARCADIUS TO IRENE, A.D. 395—800. By JOHN B. BURY, M.A., Fellow of Trinity College, Dublin. 2 vols. 8vo. [*Shortly.*]

**Classical Writers.**—Edited by JOHN RICHARD GREEN, M.A., LL.D. Fcap. 8vo. 1s. 6d. each.

EURIPIDES. By Professor MAHAFFY.

MILTON. By the Rev. STOPFORD A. BROOKE, M.A.

LIVY. By the Rev. W. W. CAPES, M.A.

VIRGIL. By Professor NETTLESHIP, M.A.

SOPHOCLES. By Professor L. CAMPBELL, M.A.

DEMOSTHENES. By Professor S. H. BUTCHER, M.A.

TACITUS. By Professor A. J. CHURCH, M.A., and W. J. BRODRIBB, M.A.

**Freeman.**—Works by EDWARD A. FREEMAN, D.C.L., LL.D., Hon. Fellow of Trinity College, Oxford, Regius Professor of Modern History in the University of Oxford.

HISTORY OF ROME. (*Historical Course for Schools.*) 18mo.

[*In preparation.*]

A SCHOOL HISTORY OF ROME. Crown 8vo. [*In preparation.*]

HISTORICAL ESSAYS. Second Series. [Greek and Roman History.] 8vo. 10s. 6d.

- Fyffe.**—A SCHOOL HISTORY OF GREECE. By C. A. FYFFE, M.A. Crown 8vo. [*In preparation.*]
- Gardner.**—SAMOS AND SAMIAN COINS. An Essay. By PERCY GARDNER, M.A., Litt.D., Professor of Archæology in the University of Oxford. With Illustrations. 8vo. 7s. 6d.
- Geddes.**—THE PROBLEM OF THE HOMERIC POEMS. By W. D. GEDDES, Principal of the University of Aberdeen. 8vo. 14s.
- Gladstone.**—Works by the Rt. Hon. W. E. GLADSTONE, M.P.  
THE TIME AND PLACE OF HOMER. Crown 8vo. 6s. 6d.  
A PRIMER OF HOMER. 18mo. 1s.
- Gow.**—A COMPANION TO SCHOOL CLASSICS. By JAMES GOW, Litt.D., Master of the High School, Nottingham; late Fellow of Trinity College, Cambridge. With Illustrations. Second Edition, Revised. Crown 8vo. 6s.
- Harrison and Verrall.**—CULTS AND MONUMENTS OF ANCIENT ATHENS. By Miss J. E. HARRISON and Mrs. A. W. VERRALL. Illustrated. Crown 8vo. [*In the press.*]
- Jebb.**—Works by R. C. JEBB, Litt.D., LL.D., Professor of Greek in the University of Cambridge.  
THE ATTIC ORATORS FROM ANTIPHON TO ISAEOS. 2 vols. 8vo. 25s.  
A PRIMER OF GREEK LITERATURE. 18mo. 15s. (See also *Classical Series.*)
- Kiepert.**—MANUAL OF ANCIENT GEOGRAPHY, Translated from the German of Dr. HEINRICH KIEPERT. Crown 8vo. 5s.
- Lanciani.**—ANCIENT ROME IN THE LIGHT OF RECENT DISCOVERIES. By RODOLFO LANCIANI, LL.D. (Harv.), Professor of Archæology in the University of Rome, Director of Excavations for the National Government and the Municipality of Rome, &c. With 100 Illustrations. Small 4to. 24s.
- Mahaffy.**—Works by J. P. MAHAFFY, M.A., D.D., Fellow and Professor of Ancient History in Trinity College, Dublin, and Hon. Fellow of Queen's College, Oxford.  
SOCIAL LIFE IN GREECE; from Homer to Menander. Fifth Edition, revised and enlarged. Crown 8vo. 9s.  
GREEK LIFE AND THOUGHT; from the Age of Alexander to the Roman Conquest. Crown 8vo. 12s. 6d.  
RAMBLES AND STUDIES IN GREECE. With Illustrations. Third Edition, Revised and Enlarged. With Map. Crown 8vo. 10s. 6d.  
A PRIMER OF GREEK ANTIQUITIES. With Illustrations. 18mo. 1s.  
EURIPIDES. 18mo. 1s. 6d. (*Classical Writers Series.*)
- Mayor (J. E. B.)**—BIBLIOGRAPHICAL CLUE TO LATIN LITERATURE. Edited after HÜBNER, with large Additions by Professor JOHN E. B. MAYOR. Crown 8vo. 10s. 6d.

- Newton.**—ESSAYS IN ART AND ARCHÆOLOGY. By Sir CHARLES NEWTON, K.C.B., D.C.L., formerly Professor of Archæology in University College, London, and Keeper of Greek and Roman Antiquities at the British Museum. 8vo. 12s. 6d.
- Sayce.**—THE ANCIENT EMPIRES OF THE EAST. By A. H. SAYCE, Deputy-Professor of Comparative Philosophy, Oxford, Hon. LL.D. Dublin. Crown 8vo. 6s.
- Stewart.**—THE TALE OF TROY. Done into English by AUBREY STEWART, M.A., late Fellow of Trinity College, Cambridge. Globe 8vo. 3s. 6d.
- Waldstein.**—CATALOGUE OF CASTS IN THE MUSEUM OF CLASSICAL ARCHÆOLOGY. By CHARLES WALDSTEIN, Litt.D., Ph.D., LL.D., University Reader in Classical Archæology, and Director of the Fitzwilliam Museum. Crown 8vo. 1s. 6d.  
\* \* Also an Edition on Large Paper, small 4to. 5s.
- Wilkins.**—A PRIMER OF ROMAN ANTIQUITIES. By Professor WILKINS, Litt. D., LL.D. Illustrated. 18mo. 1s.  
A PRIMER OF ROMAN LITERATURE. By the same Author. *[In the press.]*

## MATHEMATICS.

- (1) Arithmetic and Mensuration, (2) Algebra, (3) Euclid and Elementary Geometry, (4) Trigonometry, (5) Higher Mathematics.

### ARITHMETIC AND MENSURATION.

- Aldis.**—THE GREAT GIANT ARITHMOS. A most Elementary Arithmetic for Children. By MARY STEADMAN ALDIS. With Illustrations. Globe 8vo. 2s. 6d.
- Army Preliminary Examination, Specimens of Papers Set at the, 1882—87.**—With Answers to the Mathematical Questions. Subjects; Arithmetic, Algebra, Euclid, Geometrical Drawing, Geography, French, English Dictation. Crown 8vo. 3s. 6d.  
This selection of papers at recent Preliminary Examinations for the admission to the Army are intended for the use of Candidates preparing for these Examinations.
- Bradshaw.**—A COURSE OF EASY ARITHMETICAL EXAMPLES FOR BEGINNERS. By J. G. BRADSHAW, B.A., formerly Scholar of Jesus College, Cambridge, Assistant Master at Clifton College. Globe 8vo. 2s. With Answers, 2s. 6d.
- Brooksmith (J.).**—ARITHMETIC IN THEORY AND PRACTICE. By J. BROOKSMITH, M.A., LL.B., St. John's College, Cambridge; Barrister-at-Law; one of the Masters of Cheltenham College. New Edition, revised. Crown 8vo. 4s. 6d.



**Brooksmith.** — ELEMENTARY ARITHMETIC. By J. BROOKSMITH, M.A., LL.B., St. John's College, Cambridge; Barrister-at-Law; and sometime one of the Masters of Cheltenham College; and E. J. BROOKSMITH, B.A., LL.M., St. John's College, Cambridge; Instructor of Mathematics at the Royal Military Academy, Woolwich. Crown 8vo. *[In the press.]*

**Candler.** — HELP TO ARITHMETIC. Designed for the use of Schools. By H. CANDLER, M.A., Mathematical Master of Uppingham School. Second Edition. Extra fcap. 8vo. 2s. 6d.

**Dalton.** — RULES AND EXAMPLES IN ARITHMETIC. By the Rev. T. DALTON, M.A., Assistant-Master in Eton College. New Edition, with Answers. 18mo. 2s. 6d.

**Goyen.** — HIGHER ARITHMETIC AND ELEMENTARY MENSURATION. By P. GOYEN, Inspector of Schools, Dunedin, New Zealand. Crown 8vo. 5s.

**Hall and Knight.** — ARITHMETICAL EXERCISES AND EXAMINATION PAPERS. With an Appendix containing Questions in LOGARITHMS and MENSURATION. By H. S. HALL, M.A., formerly Scholar of Christ's College, Cambridge, Master of the Military and Engineering Side, Clifton College; and S. R. KNIGHT, B.A., formerly Scholar of Trinity College, Cambridge, late Assistant Master at Marlborough College, Authors of "Elementary Algebra," "Algebraical Exercises and Examination Papers," and "Higher Algebra," &c. Globe 8vo. 2s. 6d.

**Lock.** — Works by Rev. J. B. LOCK, M.A., Senior Fellow, Assistant Tutor, and Lecturer in Gonville and Caius College, Cambridge, formerly Master at Eton.

ARITHMETIC FOR SCHOOLS. With Answers and 1000 additional Examples for Exercise. Third Edition, revised. Stereotyped. Globe 8vo. 4s. 6d. Or in Two Parts:—Part I. Up to and including Practice. Globe 8vo. 2s. Part II. With 1000 additional Examples for Exercise. Globe 8vo. 3s.

\* \* *The complete book and the Parts can also be obtained without answers at the same price. But the editions with answers will always be supplied unless the others are specially asked for.*

A KEY TO MR. LOCK'S "ARITHMETIC FOR SCHOOLS." By the Rev. R. G. WATSON, M.A., formerly Head Master of the Dorset County School. Crown 8vo. 10s. 6d.

ARITHMETIC FOR BEGINNERS. A School Class Book of Commercial Arithmetic. Globe 8vo. 2s. 6d.

[A Key is in the press.]  
A SHILLING CLASS-BOOK OF ARITHMETIC ADAPTED FOR USE IN ELEMENTARY SCHOOLS. 18mo. *[In prep.]*

**Pedley.** — EXERCISES IN ARITHMETIC for the Use of Schools. Containing more than 7,000 original Examples. By S. PEDLEY, late of Tamworth Grammar School. Crown 8vo. 5s. Also in Two Parts 2s. 6d. each.

**Smith.**—Works by the Rev. BARNARD SMITH, M.A., late Rector of Glaston, Rutland, and Fellow and Senior Bursar of S. Peter's College, Cambridge.

**ARITHMETIC AND ALGEBRA**, in their Principles and Application; with numerous systematically arranged Examples taken from the Cambridge Examination Papers, with especial reference to the Ordinary Examination for the B.A. Degree. New Edition, carefully Revised. Crown 8vo, 10s. 6d.

**ARITHMETIC FOR SCHOOLS.** New Edition. Crown 8vo. 4s. 6d.

**A KEY TO THE ARITHMETIC FOR SCHOOLS.** New Edition. Crown 8vo. 8s. 6d.

**EXERCISES IN ARITHMETIC.** Crown 8vo, limp cloth, 2s. With Answers, 2s. 6d. Answers separately, 6d.

**SCHOOL CLASS-BOOK OF ARITHMETIC.** 18mo, cloth. 3s. Or sold separately, in Three Parts, 1s. each.

**KEYS TO SCHOOL CLASS-BOOK OF ARITHMETIC.** Parts I., II., and III., 2s. 6d. each.

**SHILLING BOOK OF ARITHMETIC FOR NATIONAL AND ELEMENTARY SCHOOLS.** 18mo, cloth. Or separately, Part I. 2d.; Part II. 3d.; Part III. 7d. Answers, 6d.

**THE SAME**, with Answers complete. 18mo, cloth. 1s. 6d.

**KEY TO SHILLING BOOK OF ARITHMETIC.** 18mo. 4s. 6d.

**EXAMINATION PAPERS IN ARITHMETIC.** 18mo. 1s. 6d. The same, with Answers, 18mo, 2s. Answers, 6d.

**KEY TO EXAMINATION PAPERS IN ARITHMETIC.** 18mo. 4s. 6d.

**THE METRIC SYSTEM OF ARITHMETIC, ITS PRINCIPLES AND APPLICATIONS**, with numerous Examples, written expressly for Standard V. in National Schools. New Edition. 18mo, cloth, sewed. 3d.

**A CHART OF THE METRIC SYSTEM**, on a Sheet, size 42 in. by 34 in. on Roller, mounted and varnished. New Edition. Price 3s. 6d.

Also a Small Chart on a Card, price 1d.

**EASY LESSONS IN ARITHMETIC**, combining Exercises in Reading, Writing, Spelling, and Dictation. Part I. for Standard I. in National Schools. Crown 8vo. 9d.

**EXAMINATION CARDS IN ARITHMETIC.** (Dedicated to Lord Sandon.) With Answers and Hints.

Standards I. and II. in box, 1s. Standards III., IV., and V., in boxes, 1s. each. Standard VI. in Two Parts, in boxes, 1s. each.

A and B papers, of nearly the same difficulty, are given so as to prevent copying, and the colours of the A and B papers differ in each Standard, and from those of every other Standard, so that a master or mistress can see at a glance whether the children have the proper papers.

**Thornton.**—**FIRST LESSONS IN BOOK-KEEPING.** By J. THORNTON. New Edition. Crown 8vo, 2s. 6d.

**A KEY TO THE ABOVE.** Oblong 4to. 10s. 6d.

- Todhunter.**—MENSURATION FOR BEGINNERS. By I. TODHUNTER, M.A., F.R.S., D.Sc., late of St. John's College, Cambridge. With Examples. New Edition. 18mo. 2s. 6d.  
**KEY TO MENSURATION FOR BEGINNERS.** By the Rev. FR. LAWRENCE MCCARTHY, Professor of Mathematics in St. Peter's College, Agra. Crown 8vo. 7s. 6d.

ALGEBRA.

- Dalton.**—RULES AND EXAMPLES IN ALGEBRA. By the Rev. T. DALTON, M.A., Assistant-Master of Eton College. Part I. New Edition. 18mo. 2s. Part II. 18mo. 2s. 6d.  
 \* \* \* *A Key to Part I. for Teachers only, 7s. 6d.*
- Hall and Knight.**—Works by H. S. HALL, M.A., formerly Scholar of Christ's College, Cambridge; Master of the Military and Engineering Side, Clifton College; and S. R. KNIGHT, B.A., formerly Scholar of Trinity College, Cambridge, late Assistant-Master at Marlborough College.
- ELEMENTARY ALGEBRA FOR SCHOOLS.** Fifth Edition, Revised and Corrected. Globe 8vo, bound in maroon coloured cloth, 3s. 6d.; with Answers, bound in green coloured cloth, 4s. 6d.
- ALGEBRAICAL EXERCISES AND EXAMINATION PAPERS.** To accompany ELEMENTARY ALGEBRA. Second Edition, revised. Globe 8vo. 2s. 6d.
- HIGHER ALGEBRA.** A Sequel to "ELEMENTARY ALGEBRA FOR SCHOOLS." Second Edition. Crown 8vo. 7s. 6d.
- SOLUTIONS OF THE EXAMPLES IN "HIGHER ALGEBRA."** Crown 8vo. 10s. 6d.
- Jones and Cheyne.**—ALGEBRAICAL EXERCISES. Progressively Arranged. By the Rev. C. A. JONES, M.A., and C. H. CHEYNE, M.A., F.R.A.S., Mathematical Masters of Westminster School. New Edition. 18mo. 2s. 6d.
- SOLUTIONS AND HINTS FOR THE SOLUTION OF SOME OF THE EXAMPLES IN THE ALGEBRAICAL EXERCISES OF MESSRS. JONES AND CHEYNE.** By Rev. W. FAILES, M.A., Mathematical Master at Westminster School, late Scholar of Trinity College, Cambridge. Crown 8vo. 7s. 6d.
- Smith (Barnard).**—ARITHMETIC AND ALGEBRA, in their Principles and Application; with numerous systematically arranged Examples taken from the Cambridge Examination Papers, with especial reference to the Ordinary Examination for the B. A. Degree. By the Rev. BARNARD SMITH, M.A., late Rector of Glaston, Rutland, and Fellow and Senior Bursar of St. Peter's College, Cambridge. New Edition, carefully Revised. Crown 8vo. 10s. 6d.
- Smith (Charles).**—Works by CHARLES SMITH, M.A., Fellow and Tutor of Sidney Sussex College, Cambridge.
- ELEMENTARY ALGEBRA.** Globe 8vo. 4s. 6d.
- In this work the author has endeavoured to explain the principles of Algebra in as simple a manner as possible for the benefit of beginners, bestowing great care upon the explanations and proofs of the fundamental operations and rules.
- A TREATISE ON ALGEBRA.** Crown 8vo. 7s. 6d.

**Smith.**—SOLUTIONS OF THE EXAMPLES IN "A TREATISE ON ALGEBRA." Crown 8vo. 10s. 6d.

**Todhunter.**—Works by I. TODHUNTER, M.A., F.R.S., D.Sc. late of St. John's College, Cambridge.

"Mr. Todhunter is chiefly known to Students of Mathematics as the author of a series of admirable mathematical text-books, which possess the rare qualities of being clear in style and absolutely free from mistakes, typographical or other."—SATURDAY REVIEW.

ALGEBRA FOR BEGINNERS. With numerous Examples. New Edition. 18mo. 2s. 6d.

KEY TO ALGEBRA FOR BEGINNERS. Crown 8vo. 6s. 6d.

ALGEBRA. For the Use of Colleges and Schools. New Edition. Crown 8vo. 7s. 6d.

KEY TO ALGEBRA FOR THE USE OF COLLEGES AND SCHOOLS. Crown 8vo. 10s. 6d.

## EUCLID, & ELEMENTARY GEOMETRY.

**Constable.**—GEOMETRICAL EXERCISES FOR BEGINNERS. By SAMUEL CONSTABLE. Crown 8vo. 3s. 6d.

**Cuthbertson.**—EUCLIDIAN GEOMETRY. By FRANCIS CUTHBERTSON, M.A., LL.D., Head Mathematical Master of the City of London School. Extra fcap. 8vo. 4s. 6d.

**Dodgson.**—Works by CHARLES L. DODGSON, M.A., Student and late Mathematical Lecturer of Christ Church, Oxford.

EUCLID. BOOKS I. AND II. Sixth Edition, with words substituted for the Algebraical Symbols used in the First Edition. Crown 8vo. 2s.

\*.\* The text of this Edition has been ascertained, by counting the words, to be less than five-sevenths of that contained in the ordinary editions.

EUCLID AND HIS MODERN RIVALS. Second Edition. Crown 8vo. 6s.

CURIOSA MATHEMATICA. Part I. A New Theory of Parallels. Second Edition. Crown 8vo. 2s.

**Dupuis.**—ELEMENTARY SYNTHETIC GEOMETRY OF THE POINT, LINE AND CIRCLE IN THE PLANE. By N. F. DUPUIS, M.A., F.R.S.C., Professor of Pure Mathematics in the University of Queen's College, Kingston, Canada. Globe 8vo. 4s. 6d.

**Eagles.**—CONSTRUCTIVE GEOMETRY OF PLANE CURVES. By T. H. EAGLES, M.A., Instructor in Geometrical Drawing, and Lecturer in Architecture at the Royal Indian Engineering College, Cooper's Hill. With numerous Examples. Crown 8vo. 12s.

**Hall and Stevens.**—A TEXT BOOK OF EUCLID'S ELEMENTS. Including alternative Proofs, together with additional Theorems and Exercises, classified and arranged. By H. S. HALL, M.A., formerly Scholar of Christ's College, Cambridge, and F. H. STEVENS, M.A., formerly Scholar of Queen's College, Oxford; Masters of the Military and Engineering Side, Clifton College. Globe 8vo. Books I.—VI. 4s. 6d. Book I. 1s. Books I. and II. Second Edition. 1s. 6d. Books I.—IV. 3s. Books III.—VI. 2s.

- Halsted.**—THE ELEMENTS OF GEOMETRY. By GEORGE BRUCE HALSTED, Professor of Pure and Applied Mathematics in the University of Texas. 8vo. 12s. 6d.
- Kitchener.**—A GEOMETRICAL NOTE-BOOK, containing Easy Problems in Geometrical Drawing preparatory to the Study of Geometry. For the Use of Schools. By F. E. KITCHENER, M.A., Head-Master of the Grammar School, Newcastle, Staffordshire. New Edition. 4to. 2s.
- Lock.**—EUCLID FOR BEGINNERS. Being an Introduction to existing Text-books. By Rev. J. B. LOCK, M.A., author of "Arithmetic for Schools," "Trigonometry," "Dynamics," "Elementary Statics," &c. [*In preparation.*]
- Mault.**—NATURAL GEOMETRY: an Introduction to the Logical Study of Mathematics. For Schools and Technical Classes With Explanatory Models, based upon the Tachymetrical works of Ed. Lagout. By A. MAULT. 18mo. 1s.  
Models to illustrate the above, in Box, 12s. 6d.
- Millar.**—ELEMENTS OF DESCRIPTIVE GEOMETRY. By J. B. MILLAR, M.E., Civil Engineer, Lecturer on Engineering in the Victoria University, Manchester. Second Edition. Cr. 8vo. 6s.
- Stevens.**—Works by F. H. STEVENS, M.A., formerly Scholar of Queen's College, Cambridge, Master of the Military and Engineering side, Clifton College.  
EUCLID. BOOK XI. Propositions 1—21 with alternative proofs, Exercises, and Additional Theorems and Examples. Globe 8vo. [*In the press.*]  
ELEMENTARY MENSURATION, with exercises in the mensuration of Plane and Solid Figures. Globe 8vo. [*In the press.*]
- Syllabus of Plane Geometry** (corresponding to Euclid, Books I.—VI.). Prepared by the Association for the Improvement of Geometrical Teaching. New Edition. Crown 8vo. 1s. [*In the press.*]
- Syllabus of Modern Plane Geometry.**—Association for the Improvement of Geometrical Teaching. Crown 8vo. Sewed. 1s.
- Todhunter.**—THE ELEMENTS OF EUCLID. For the Use of Colleges and Schools. By I. TODHUNTER, M.A., F.R.S., D.Sc., of St. John's College, Cambridge. New Edition: 18mo. 3s. 6d.
- KEY TO EXERCISES IN EUCLID. Crown 8vo. 6s. 6d.
- Wilson (J. M.).**—ELEMENTARY GEOMETRY. BOOKS I.—V. Containing the Subjects of Euclid's first Six Books. Following the Syllabus of the Geometrical Association. By the Rev. J. M. WILSON, M.A., Head Master of Clifton College. New Edition. Extra fcap. 8vo. 4s. 6d.

## TRIGONOMETRY.

- Beasley.**—AN ELEMENTARY TREATISE ON PLANE TRIGONOMETRY. With Examples. By R. D. BEASLEY, M.A. Ninth Edition, revised and enlarged. Crown 8vo. 3s. 6d.

**Johnson.**—A TREATISE ON TRIGONOMETRY. By W. B. JOHNSON, M.A., late Scholar and Assistant Lecturer in Mathematics of King's College, Cambridge. Crown 8vo. 8s. 6d.

**Lock.**—Works by Rev. J. B. LOCK, M.A., Senior Fellow, Assistant Tutor and Lecturer in Gonville and Caius College, Cambridge; formerly Master at Eton.

TRIGONOMETRY FOR BEGINNERS, as far as the Solution of Triangles. Globe 8vo. 2s. 6d.

A KEY TO "TRIGONOMETRY FOR BEGINNERS." Adapted from the key to "Elementary Trigonometry." Crown 8vo. 6s. 6d.

ELEMENTARY TRIGONOMETRY. Sixth Edition (in this edition the chapter on logarithms has been carefully revised.) Globe 8vo. 4s. 6d.

Mr. E. J. ROUGH, D.Sc., F.R.S., writes:—"It is an able treatise. It takes the difficulties of the subject one at a time, and so leads the young student easily along."

A KEY TO "ELEMENTARY TRIGONOMETRY." By HENRY CARR, B.A., of the Grammar School, Lagos, West Africa. Crown 8vo. 8s. 6d.

HIGHER TRIGONOMETRY. Fifth Edition. Globe 8vo. 4s. 6d.

Both Parts complete in One Volume. Globe 8vo. 7s. 6d.

(See also under *Arithmetic, Higher Mathematics, and Euclid.*)

**M'Clelland and Preston.**—A TREATISE ON SPHERICAL TRIGONOMETRY. With applications to Spherical Geometry and numerous Examples. By WILLIAM J. M'CLELLAND, M.A., Principal of the Incorporated Society's School, Santry, Dublin, and THOMAS PRESTON, Sch.B.A. In Two Parts. Crown 8vo. Part I. To the End of Solution of Triangles, 4s. 6d. Part II., 5s. Both Parts in one Volume. 8s. 6d.

**Palmer.**—TEXT-BOOK OF PRACTICAL LOGARITHMS AND TRIGONOMETRY. By J. H. PALMER, Head Schoolmaster R.N., H.M.S. Cambridge, Devonport. Globe 8vo. 4s. 6d.

**Snowball.**—THE ELEMENTS OF PLANE AND SPHERICAL TRIGONOMETRY. By J. C. SNOWBALL, M.A. Fourteenth Edition. Crown 8vo. 7s. 6d.

**Todhunter.**—Works by I. TODHUNTER, M.A., F.R.S., D.Sc., late of St. John's College, Cambridge.

TRIGONOMETRY FOR BEGINNERS. With numerous Examples. New Edition. 18mo. 2s. 6d.

KEY TO TRIGONOMETRY FOR BEGINNERS. Cr. 8vo. 8s. 6d.

PLANE TRIGONOMETRY. For Schools and Colleges. New Edition. Crown 8vo. 5s.

KEY TO PLANE TRIGONOMETRY. Crown 8vo. 10s. 6d.

A TREATISE ON SPHERICAL TRIGONOMETRY. New Edition, enlarged. Crown 8vo. 4s. 6d.

(See also under *Arithmetic and Mensuration, Algebra, and Higher Mathematics.*)

HIGHER MATHEMATICS.

- Airy.**—Works by Sir G. B. AIRY, K. C. B., formerly Astronomer-Royal.  
**ELEMENTARY TREATISE ON PARTIAL DIFFERENTIAL EQUATIONS.** Designed for the Use of Students in the Universities. With Diagrams. Second Edition. Crown 8vo. 5s. 6d.  
**ON THE ALGEBRAICAL AND NUMERICAL THEORY OF ERRORS OF OBSERVATIONS AND THE COMBINATION OF OBSERVATIONS.** Second Edition, revised. Crown 8vo. 6s. 6d.
- Alexander (T.).**—**ELEMENTARY APPLIED MECHANICS.** Being the simpler and more practical Cases of Stress and Strain wrought out individually from first principles by means of Elementary Mathematics. By T. ALEXANDER, C.E., Professor of Civil Engineering, Trinity College, Dublin. Part I. Crown 8vo. 4s. 6d.
- Alexander and Thomson.**—**ELEMENTARY APPLIED MECHANICS.** By THOMAS ALEXANDER, C.E., Professor of Civil Engineering, Trinity College, Dublin, and ARTHUR WATSON THOMSON, C.E., B.Sc., Professor of Engineering at the Technical College, Glasgow. Part II. TRANSVERSE STRESS. Crown 8vo. 10s. 6d.
- Army Preliminary Examination, 1882-1887,** Specimens of Papers set at the: With answers to the Mathematical Questions. Subjects: Arithmetic, Algebra, Euclid, Geometrical Drawing, Geography, French, English Dictation. Cr. 8vo. 3s. 6d.
- Ball (W. W. R.).**—**A SHORT ACCOUNT OF THE HISTORY OF MATHEMATICS.** By W. W. ROUSE BALL, Fellow and Assistant Tutor of Trinity College, Cambridge, and of the Inner Temple, Barrister-at-Law. Crown 8vo. 10s. 6d.
- Ball (Sir R. S.).**—**EXPERIMENTAL MECHANICS.** A Course of Lectures delivered at the Royal College of Science for Ireland. By SIR ROBERT STAWELL BALL, LL.D., F.R.S., Astronomer-Royal of Ireland. New Edition. With Illustrations. Crown 8vo. 6s.
- Boole.**—**THE CALCULUS OF FINITE DIFFERENCES.** By G. BOOLE, D.C.L., F.R.S., late Professor of Mathematics in the Queen's University, Ireland. Third Edition, revised by J. F. MOULTON, Q.C. Crown 8vo. 10s. 6d.
- Cambridge Senate-House Problems and Riders, with Solutions:—**
- 1875—**PROBLEMS AND RIDERS.** By A. G. GREENHILL, M.A. Crown 8vo. 8s. 6d.
- 1878—**SOLUTIONS OF SENATE-HOUSE PROBLEMS.** By the Mathematical Moderators and Examiners, Edited by J. W. L. GLAISHER, M.A., Fellow of Trinity College, Cambridge. 12s.

- Carll.**—A TREATISE ON THE CALCULUS OF VARIATIONS. Arranged with the purpose of introducing, as well as illustrating, its Principles to the Reader by means of Problems, and Designed to present in all Important Particulars a Complete View of the Present State of the Science. By LEWIS BUFFETT CARLL, A.M. Demy 8vo. 21s.
- Cheyne.**—AN ELEMENTARY TREATISE ON THE PLANETARY THEORY. By C. H. H. CHEYNE, M.A., F.R.A.S. With a Collection of Problems. Third Edition. Edited by Rev. A. FREEMAN, M.A., F.R.A.S. Crown 8vo. 7s. 6d.
- Christie.**—A COLLECTION OF ELEMENTARY TEST-QUESTIONS IN PURE AND MIXED MATHEMATICS; with Answers and Appendices on Synthetic Division, and on the Solution of Numerical Equations by Horner's Method. By JAMES R. CHRISTIE, F.R.S., Royal Military Academy, Woolwich. Crown 8vo. 8s. 6d.
- Clausius.**—MECHANICAL THEORY OF HEAT. By R. CLAUDIUS. Translated by WALTER R. BROWNE, M.A., late Fellow of Trinity College, Cambridge. Crown 8vo. 10s. 6d.
- Clifford.**—THE ELEMENTS OF DYNAMIC. An Introduction to the Study of Motion and Rest in Solid and Fluid Bodies. By W. K. CLIFFORD, F.R.S., late Professor of Applied Mathematics and Mechanics at University College, London. Part I.—KINEMATIC. Crown 8vo. Books I—III, 7s. 6d.; Book IV. and Appendix. 6s.
- Cockshott and Walters.**—A TREATISE ON GEOMETRICAL CONICS. In accordance with the Syllabus of the Association for the Improvement of Geometrical Teaching. By A. COCKSHOT, M.A., formerly Fellow and Assistant-Tutor of Trinity College, Cambridge; Assistant-Master at Eton; and Rev. F. B. WALTERS, M.A., Fellow of Queens' College, Cambridge, and Principal of King William's College, Isle of Man. With Diagrams. Crown 8vo. 5s.
- Cotterill.**—APPLIED MECHANICS: an Elementary General Introduction to the Theory of Structures and Machines. By JAMES H. COTTERILL, F.R.S., Associate Member of the Council of the Institution of Naval Architects, Associate Member of the Institution of Civil Engineers, Professor of Applied Mechanics in the Royal Naval College, Greenwich. Medium 8vo. 18s.
- ELEMENTARY MANUAL OF APPLIED MECHANICS. By the same Author. Crown 8vo. [In preparation.]
- Day (R. E.)**—ELECTRIC LIGHT ARITHMETIC. By R. E. DAY, M.A., Evening Lecturer in Experimental Physics at King's College, London. Fott 8vo. 2s.
- Day.**—PROPERTIES OF CONIC SECTIONS PROVED GEOMETRICALLY. Part I. The Ellipse with an ample collection of Problems. By the Rev. H. G. DAY, M.A., formerly Fellow of St. John's College, Cambridge. Crown 8vo. 3s. 6d.



- Dodgson.**—**CURIOSA MATHEMATICA.** Part I. A New Theory of Parallels. By CHARLES L. DODGSON, M.A., Student and late Mathematical Lecturer of Christ Church, Oxford, Author of "Euclid and his Modern Rivals," "Euclid, Books I. and II.," &c. Second Edition. Crown 8vo. 2s.
- Drew.**—**GEOMETRICAL TREATISE ON CONIC SECTIONS.** By W. H. DREW, M.A., St. John's College, Cambridge. New Edition, enlarged. Crown 8vo. 5s.
- Dyer.**—**EXERCISES IN ANALYTICAL GEOMETRY.** Compiled and arranged by J. M. DYER, M.A. With Illustrations. Crown 8vo. 4s. 6d.
- Eagles.**—**CONSTRUCTIVE GEOMETRY OF PLANE CURVES.** By T. H. EAGLES, M.A., Instructor in Geometrical Drawing, and Lecturer in Architecture at the Royal Indian Engineering College, Cooper's Hill. With numerous Examples. Crown 8vo. 12s.
- Edgar (J. H.) and Pritchard (G. S.)**—**NOTE-BOOK ON PRACTICAL SOLID OR DESCRIPTIVE GEOMETRY.** Containing Problems with help for Solutions. By J. H. EDGAR, M.A., Lecturer on Mechanical Drawing at the Royal School of Mines, and G. S. PRITCHARD. Fourth Edition, revised by ARTHUR MEEZE. Globe 8vo. 4s. 6d.
- Edwards.**—**THE DIFFERENTIAL CALCULUS** With Applications and numerous Examples. An Elementary Treatise by JOSEPH EDWARDS, M.A., formerly Fellow of Sidney Sussex College, Cambridge. Crown 8vo. 10s. 6d.
- Ferrers.**—Works by the Rev. N. M. FERRERS, M.A., Master of Gonville and Caius College, Cambridge.
- AN ELEMENTARY TREATISE ON TRILINEAR COORDINATES, the Method of Reciprocal Polars, and the Theory of Projectors. New Edition, revised. Crown 8vo. 6s. 6d.
- AN ELEMENTARY TREATISE ON SPHERICAL HARMONICS, AND SUBJECTS CONNECTED WITH THEM. Crown 8vo. 7s. 6d.
- Forsyth.**—**A TREATISE ON DIFFERENTIAL EQUATIONS.** By ANDREW RUSSELL FORSYTH, M.A., F.R.S., Fellow and Assistant Tutor of Trinity College, Cambridge. 8vo. 14s.
- Frost.**—Works by PERCIVAL FROST, M.A., D.Sc., formerly Fellow of St. John's College, Cambridge; Mathematical Lecturer at King's College.
- AN ELEMENTARY TREATISE ON CURVE TRACING. 8vo. 12s.
- SOLID GEOMETRY. Third Edition. Demy 8vo. 16s.
- HINTS FOR THE SOLUTION OF PROBLEMS in the Third Edition of SOLID GEOMETRY. 8vo. 8s. 6d.

- Greaves.**—A TREATISE ON ELEMENTARY STATICS. By JOHN GREAVES, M.A., Fellow and Mathematical Lecturer of Christ's College, Cambridge. Second Edition. Crown 8vo. 6s. 6d.  
 STATICS FOR BEGINNERS. By the Same Author. Globe 8vo. 3s. 6d.
- Greenhill.**—DIFFERENTIAL AND INTEGRAL CALCULUS. With Applications. By A. G. GREENHILL, M.A., Professor of Mathematics to the Senior Class of Artillery Officers, Woolwich, and Examiner in Mathematics to the University of London. Crown 8vo. 7s. 6d.
- Hayward.**—THE ALGEBRA OF CO-PLANAR VECTORS AND TRIGONOMETRY. By R. B. HAYWARD, F.R.S., Assistant Master at Harrow. [*In preparation.*]
- Hicks.**—DYNAMICS OF PARTICLES AND SOLIDS. By W. M. HICKS, Principal, and Professor of Mathematics, and Physics, Firth College, Sheffield, late Fellow of St. John's College, Cambridge. Crown 8vo. [*In preparation.*]
- Ibbetson.**—THE MATHEMATICAL THEORY OF PERFECTLY ELASTIC SOLIDS, with a short account of Viscous Fluids. An Elementary Treatise. By WILLIAM JOHN IBBETSON, M.A., Fellow of the Royal Astronomical Society, and of the Cambridge Philosophical Society, Member of the London Mathematical Society, late Senior Scholar of Clare College, Cambridge. 8vo. 21s.
- Jellett (John H.).**—A TREATISE ON THE THEORY OF FRICTION. By JOHN H. JELLETT, B.D., late Provost of Trinity College, Dublin; President of the Royal Irish Academy. 8vo. 8s. 6d.
- Johnson.**—Works by WILLIAM WOOLSEY JOHNSON, Professor of Mathematics at the U.S. Naval Academy, Annapolis, Maryland.  
 INTEGRAL CALCULUS, an Elementary Treatise on the; Founded on the Method of Rates or Fluxions. Demy 8vo. 9s.  
 CURVE TRACING IN CARTESIAN CO-ORDINATES. Crown 8vo. 4s. 6d.  
 A TREATISE ON ORDINARY AND DIFFERENTIAL EQUATIONS. Extra crown 8vo. [*In the press.*]
- Jones.**—EXAMPLES IN PHYSICS. By D. E. JONES, B.Sc., Professor of Physics in University College of Wales, Aberystwyth. Fcap. 8vo. 3s. 6d.
- Kelland and Tait.**—INTRODUCTION TO QUATERNIONS, with numerous examples. By P. KELLAND, M.A., F.R.S., and P. G. TAIT, M.A., Professors in the Department of Mathematics in the University of Edinburgh. Second Edition. Crown 8vo. 7s. 6d.
- Kempe.**—HOW TO DRAW A STRAIGHT LINE: a Lecture on Linkages. By A. B. KEMPE. With Illustrations. Crown 8vo. 1s. 6d. (*Nature Series.*)

- Kennedy.**—THE MECHANICS OF MACHINERY. By A. B. W. KENNEDY, F.R.S., M.Inst.C.E., Professor of Engineering and Mechanical Technology in University College, London. With Illustrations. Crown 8vo. 12s. 6d.
- Knox.**—DIFFERENTIAL CALCULUS FOR BEGINNERS. By ALEXANDER KNOX. Fcap. 8vo. 3s. 6d.
- Lock.**—Works by the Rev. J. B. LOCK, M.A., Author of "Trigonometry," "Arithmetic for Schools," &c.  
HIGHER TRIGONOMETRY. Fifth Edition. Globe 8vo. 4s. 6d.  
DYNAMICS FOR BEGINNERS. Second Edition. (Stereo-typed.) Globe 8vo. 3s. 6d.  
ELEMENTARY STATICS. Globe 8vo. 4s. 6d.  
(See also under *Arithmetic, Euclid, and Trigonometry.*)
- Lupton.**—CHEMICAL ARITHMETIC. With 1,200 Examples. By SYDNEY LUPTON, M.A., F.C.S., F.I.C., formerly Assistant-Master in Harrow School. Second Edition. Fcap. 8vo. 4s. 6d.
- Macfarlane.**—PHYSICAL ARITHMETIC. By ALEXANDER MACFARLANE, M.A., D.Sc., F.R.S.E., Examiner in Mathematics to the University of Edinburgh. Crown 8vo. 7s. 6d.
- MacGregor.**—KINEMATICS AND DYNAMICS. An Elementary Treatise. By JAMES GORDON MACGREGOR, M.A., D.Sc., Fellow of the Royal Societies of Edinburgh and of Canada, Munro Professor of Physics in Dalhousie College, Halifax, Nova Scotia. With Illustrations. Crown 8vo. 10s. 6d.
- Merriman.**—A TEXT BOOK OF THE METHOD OF LEAST SQUARES. By MANSFIELD MERRIMAN, Professor of Civil Engineering at Lehigh University, Member of the American Philosophical Society, American Association for the Advancement of Science, &c. Demy 8vo. 8s. 6d.
- Millar.**—ELEMENTS OF DESCRIPTIVE GEOMETRY. By J. B. MILLAR, C.E., Assistant Lecturer in Engineering in Owens College, Manchester. Second Edition. Crown 8vo. 6s.
- Milne.**—Works by the Rev. JOHN J. MILNE, M.A., Private Tutor, late Scholar, of St. John's College, Cambridge, &c., &c., formerly Second Master of Heversham Grammar School.  
WEEKLY PROBLEM PAPERS. With Notes intended for the use of students preparing for Mathematical Scholarships, and for the Junior Members of the Universities who are reading for Mathematical Honours. Pott 8vo. 4s. 6d.  
SOLUTIONS TO WEEKLY PROBLEM PAPERS. Crown 8vo. 10s. 6d.  
COMPANION TO "WEEKLY PROBLEM PAPERS." Crown 8vo. 10s. 6d.
- Muir.**—A TREATISE ON THE THEORY OF DETERMINANTS. With graduated sets of Examples. For use in Colleges and Schools. By THOS. MUIR, M.A., F.R.S.E., Mathematical Master in the High School of Glasgow. Crown 8vo. 7s. 6d.

**Palmer.**—TEXT BOOK OF PRACTICAL LOGARITHMS AND TRIGONOMETRY. By J. H. PALMER, Head Schoolmaster R.N., H.M.S. *Cambridge*, Devonport. Globe 8vo. 4s. 6d.

**Parkinson.**—AN ELEMENTARY TREATISE ON MECHANICS. For the Use of the Junior Classes at the University and the Higher Classes in Schools. By S. PARKINSON, D.D., F.R.S., Tutor and Praeceptor of St. John's College, Cambridge. With a Collection of Examples. Sixth Edition, revised. Crown 8vo. 9s. 6d.

**Pirie.**—LESSONS ON RIGID DYNAMICS. By the Rev. G. PIRIE, M.A., late Fellow and Tutor of Queen's College, Cambridge; Professor of Mathematics in the University of Aberdeen. Crown 8vo. 6s.

**Puckle.**—AN ELEMENTARY TREATISE ON CONIC SECTIONS AND ALGEBRAIC GEOMETRY. With Numerous Examples and Hints for their Solution; especially designed for the Use of Beginners. By G. H. PUCKLE, M.A. Fifth Edition, revised and enlarged. Crown 8vo. 7s. 6d.

**Reuleaux.**—THE KINEMATICS OF MACHINERY. Outlines of a Theory of Machines. By Professor F. REULEAUX. Translated and Edited by Professor A. B. W. KENNEDY, F.R.S. C.E. With 450 Illustrations. Medium 8vo. 21s.

**Rice and Johnson.**—DIFFERENTIAL CALCULUS, an Elementary Treatise on the; Founded on the Method of Rates or Fluxions. By JOHN MINOT RICE, Professor of Mathematics in the United States Navy, and WILLIAM WOOLSEY JOHNSON, Professor of Mathematics at the United States Naval Academy. Third Edition, Revised and Corrected. Demy 8vo. 18s. Abridged Edition, 9s.

**Robinson.**—TREATISE ON MARINE SURVEYING. Prepared for the use of younger Naval Officers. With Questions for Examinations and Exercises principally from the Papers of the Royal Naval College. With the results. By Rev. JOHN L. ROBINSON, Chaplain and Instructor in the Royal Naval College, Greenwich. With Illustrations. Crown 8vo. 7s. 6d.

CONTENTS.—Symbols used in Charts and Surveying—The Construction and Use of Scales—Laying off Angles—Fixing Positions by Angles—Charts and Chart-Drawing—Instruments and Observing—Base Lines—Triangulation—Levelling—Tides and Tidal Observations—Soundings—Chronometers—Meridian Distances—Method of Plotting a Survey—Miscellaneous Exercises—Index.

**Routh.**—Works by EDWARD JOHN ROUTH, D.Sc., LL.D., F.R.S., Fellow of the University of London, Hon. Fellow of St. Peter's College, Cambridge.

A TREATISE ON THE DYNAMICS OF THE SYSTEM OF RIGID BODIES. With numerous Examples. Fourth and enlarged Edition. Two Vols. 8vo. Vol. I.—Elementary Parts. 14s. Vol. II.—The Advanced Parts. 14s.

STABILITY OF A GIVEN STATE OF MOTION, PARTICULARLY STEADY MOTION. Adams' Prize Essay for 1877. 8vo. 8s. 6d.

- Sanderson.**—HYDROSTATICS FOR BEGINNERS. By F. W. SANDERSON, M.A., late Fellow of the University of Durham, and Scholar of Christ's College, Cambridge; Assistant Master in Dulwich College. Globe 8vo. [In the press.]
- Smith (C.)**.—Works by CHARLES SMITH, M.A., Fellow and Tutor of Sidney Sussex College, Cambridge.  
 CONIC SECTIONS. Seventh Edition. Crown 8vo. 7s. 6d.  
 SOLUTIONS TO CONIC SECTIONS. Crown 8vo. 10s. 6d.  
 AN ELEMENTARY TREATISE ON SOLID GEOMETRY. Second Edition. Crown 8vo. 9s. 6d. (See also under *Algebra*.)
- Syllabus of Elementary Dynamics.** Drawn up by the Association for the Improvement of Geometrical Teaching. 4to. Part I. [In preparation.]
- Tait and Steele.**—A TREATISE ON DYNAMICS OF A PARTICLE. With numerous Examples. By Professor TAIT, M.A., and W. J. STEELE, B.A. Fifth Edition, revised. Crown 8vo. 12s.
- Thomson.**—Works by J. J. THOMSON, Fellow of Trinity College, Cambridge, and Professor of Experimental Physics in the University.  
 A TREATISE ON THE MOTION OF VORTEX RINGS. An Essay to which the Adams Prize was adjudged in 1882 in the University of Cambridge. With Diagrams. 8vo. 6s.  
 APPLICATIONS OF DYNAMICS TO PHYSICS AND CHEMISTRY. Crown 8vo. 7s. 6d.
- Todhunter.**—Works by I. TODHUNTER, M.A., F.R.S., D.Sc., late of St. John's College, Cambridge.  
 "Mr. Todhunter is chiefly known to students of Mathematics as the author of a series of admirable mathematical text-books, which possess the rare qualities of being clear in style and absolutely free from mistakes, typographical and other."—SATURDAY REVIEW.  
 MECHANICS FOR BEGINNERS. With numerous Examples. New Edition. 18mo. 4s. 6d.  
 KEY TO MECHANICS FOR BEGINNERS. Crown 8vo. 6s. 6d.  
 AN ELEMENTARY TREATISE ON THE THEORY OF EQUATIONS. New Edition, revised. Crown 8vo. 7s. 6d.  
 PLANE CO-ORDINATE GEOMETRY, as applied to the Straight Line and the Conic Sections. With numerous Examples. New Edition, revised and enlarged. Crown 8vo. 7s. 6d.  
 KEY TO PLANE CO-ORDINATE GEOMETRY. By C. W. BOURNE, M.A. Head Master of the College, Inverness. Crown 8vo. 10s. 6d.  
 A TREATISE ON THE DIFFERENTIAL CALCULUS. With numerous Examples. New Edition. Crown 8vo. 10s. 6d.  
 A KEY TO DIFFERENTIAL CALCULUS. By H. ST. J. HUNTER, M.A. Crown 8vo. 10s. 6d.  
 A TREATISE ON THE INTEGRAL CALCULUS AND ITS APPLICATIONS. With numerous Examples. New Edition, revised and enlarged. Crown 8vo. 10s. 6d. KEY. [In the press.]  
 EXAMPLES OF ANALYTICAL GEOMETRY OF THREE DIMENSIONS. New Edition, revised. Crown 8vo. 4s.

**Todhunter.**—A TREATISE ON ANALYTICAL STATICS. With numerous Examples. Fifth Edition. Edited by Professor J. D. EVERETT, F.R.S. Crown 8vo. 10s. 6d.

A HISTORY OF THE MATHEMATICAL THEORY OF PROBABILITY, from the time of Pascal to that of Laplace. 8vo. 18s.

A HISTORY OF THE MATHEMATICAL THEORIES OF ATTRACTION, AND THE FIGURE OF THE EARTH, from the time of Newton to that of Laplace. 2 vols. 8vo. 24s.

AN ELEMENTARY TREATISE ON LAPLACE'S, LAME'S, AND BESSEL'S FUNCTIONS. Crown 8vo. 10s. 6d.

(See also under *Arithmetic and Mensuration, Algebra, and Trigonometry.*)

**Wilson (J. M.).**—SOLID GEOMETRY AND CONIC SECTIONS. With Appendices on Transversals and Harmonic Division. For the Use of Schools. By Rev. J. M. WILSON, M.A. Head Master of Clifton College. New Edition. Extra fcap. 8vo. 3s. 6d.

**Woolwich Mathematical Papers**, for Admission into the Royal Military Academy, Woolwich, 1880—1888 inclusive. Edited by E. J. BROOKSMITH, B.A., LL.M., St. John's College, Cambridge; Instructor in Mathematics at the Royal Military Academy, Woolwich. Crown 8vo. 6s.

**Wolstenholme.**—MATHEMATICAL PROBLEMS, on Subjects included in the First and Second Divisions of the Schedule of subjects for the Cambridge Mathematical Tripos Examination. Devised and arranged by JOSEPH WOLSTENHOLME, D.Sc., late Fellow of Christ's College, sometime Fellow of St. John's College, and Professor of Mathematics in the Royal Indian Engineering College. New Edition, greatly enlarged. 8vo. 18s.

EXAMPLES FOR PRACTICE IN THE USE OF SEVEN-FIGURE LOGARITHMS. For the Use of Colleges and Schools. By the same Author. 8vo. 5s.

---

## SCIENCE.

(1) Natural Philosophy, (2) Astronomy, (3) Chemistry, (4) Biology, (5) Medicine, (6) Anthropology, (7) Physical Geography and Geology, (8) Agriculture.

### NATURAL PHILOSOPHY.

**Airy.**—Works by Sir G. B. AIRY, K.C.B., formerly Astronomer Royal.

ON SOUND AND ATMOSPHERIC VIBRATIONS. With the Mathematical Elements of Music. Designed for the Use of Students in the University. Second Edition, revised and enlarged. Crown 8vo. 9s.

A TREATISE ON MAGNETISM. Designed for the Use of Students in the University. Crown 8vo. 9s. 6d.

- Airy.**—GRAVITATION: an Elementary Explanation of the Principal Perturbations in the Solar System. Second Edition. Crown 8vo. 7s. 6d.
- Alexander (T.).**—ELEMENTARY APPLIED MECHANICS. Being the simpler and more practical Cases of Stress and Strain wrought out individually from first principles by means of Elementary Mathematics. By T. ALEXANDER, C.E., Professor of Civil Engineering, Trinity College, Dublin. Crown 8vo. Part I. 4s. 6d.
- Alexander — Thomson.** — ELEMENTARY APPLIED MECHANICS. By THOMAS ALEXANDER, C.E., Professor of Civil Engineering, Trinity College, Dublin, and ARTHUR WATSON THOMSON, C.E., B.Sc., Professor of Engineering at the Technical College, Glasgow. Part II. TRANSVERSE STRESS; upwards of 150 Diagrams, and 200 Examples carefully worked out. Crown 8vo. 10s. 6d.
- Ball (R. S.).**—EXPERIMENTAL MECHANICS. A Course of Lectures delivered at the Royal College of Science for Ireland. By Sir R. S. BALL, LL.D., F.R.S., Astronomer Royal of Ireland. Second and Cheaper Edition. With Illustrations. Crown 8vo. 6s.
- Bottomley.**—FOUR-FIGURE MATHEMATICAL TABLES. Comprising Logarithmic and Trigonometrical Tables, and Tables of Squares, Square Roots, and Reciprocals. By J. T. BOTTOMLEY, M.A., F.R.S.E., F.C.S., Lecturer in Natural Philosophy in the University of Glasgow. 8vo. 2s. 6d.
- Chisholm.**—THE SCIENCE OF WEIGHING AND MEASURING, AND THE STANDARDS OF MEASURE AND WEIGHT. By H. W. CHISHOLM, Warden of the Standards. With numerous Illustrations. Crown 8vo. 4s. 6d. (*Nature Series*).
- Clarke.**—A TABLE OF SPECIFIC GRAVITY FOR SOLIDS AND LIQUIDS. (Constants of Nature: Part I.) New Edition. Revised and Enlarged. By FRANK WIGGLESWORTH CLARKE, Chief Chemist, U.S. Geological Survey. 8vo, 12s. 6d. (Published for the Smithsonian Institution, Washington, U.S. of America.)
- Clausius.**—MECHANICAL THEORY OF HEAT. By R. CLAUDIUS. Translated by WALTER R. BROWNE, M.A., late Fellow of Trinity College, Cambridge. Crown 8vo 10s. 6d.
- Cotterill.**—APPLIED MECHANICS: an Elementary General Introduction to the Theory of Structures and Machines. By JAMES H. COTTERILL, F.R.S., Associate Member of the Council of the Institution of Naval Architects, Associate Member of the Institution of Civil Engineers, Professor of Applied Mechanics in the Royal Naval College, Greenwich. Medium 8vo. 18s.
- ELEMENTARY MANUAL OF APPLIED MECHANICS.  
By the same Author. Crown 8vo. [*In preparation.*]
- Cumming.**—AN INTRODUCTION TO THE THEORY OF ELECTRICITY. By LINNÆUS CUMMING, M.A., one of the Masters of Rugby School. With Illustrations. Crown 8vo, 8s. 6d.

- Daniell.**—A TEXT-BOOK OF THE PRINCIPLES OF PHYSICS. By ALFRED DANIELL, M.A., LL.B., D.Sc., F.R.S.E., late Lecturer on Physics in the School of Medicine, Edinburgh. With Illustrations. Second Edition. Revised and Enlarged. Medium 8vo. 21s.
- Day.**—ELECTRIC LIGHT ARITHMETIC. By R. E. DAY, M.A., Evening Lecturer in Experimental Physics at King's College, London. Pott 8vo. 2s.
- Everett.**—UNITS AND PHYSICAL CONSTANTS. By J. D. EVERETT, M.A., D.C.L., F.R.S., F.R.S.E., Professor of Natural Philosophy, Queen's College, Belfast. Second Edition. Extra fcap. 8vo. 5s.
- Gray.**—THE THEORY AND PRACTICE OF ABSOLUTE MEASUREMENTS IN ELECTRICITY AND MAGNETISM. By ANDREW GRAY, M.A., F.R.S.E., Professor of Physics in the University College of North Wales. Two Vols. Crown 8vo. Vol. I. 12s. 6d. [Vol. II. *In the press.*]  
ABSOLUTE MEASUREMENTS IN ELECTRICITY AND MAGNETISM FOR BEGINNERS. By the same Author. Abridged Edition. Fcap. 8vo. [*In preparation.*]
- Greaves.**—ELEMENTARY STATICS, A TREATISE ON. By JOHN GREAVES, M.A., Fellow and Mathematical Lecturer of Christ's College, Cambridge. Second Edition, revised. Crown 8vo. 6s. 6d.  
STATICS FOR BEGINNERS. By the same. Crown 8vo. 3s. 6d.
- Grove.**—A DICTIONARY OF MUSIC AND MUSICIANS. (A.D. 1450—1889). By Eminent Writers, English and Foreign. Edited by Sir GEORGE GROVE, D.C.L., Director of the Royal College of Music, &c. In four volumes. Demy 8vo.  
Vols. I., II., III., and IV. Price 21s. each.  
Vol. I. A to IMPROMPTU. Vol. II. IMPROPERIA to PLAIN SONG. Vol. III. PLANCHÉ to SUMER IS ICUMEN IN. Vol. IV. SUMER IS ICUMEN IN to ZWISCHENSPIEL, and APPENDIX. Demy 8vo. cloth, with Illustrations in Music Type and Woodcut. Also published in Parts. Parts I. to XIV., Parts XIX—XXII., price 3s. 6d. each. Parts XV., XVI., price 7s. Parts XVII., XVIII., price 7s. Parts XXIII.—XXV. (Appendix), 9s.
- \* \* The Appendix just published completes the Dictionary. A general Index will be published as a separate volume.  
"Dr. Grove's Dictionary will be a boon to every intelligent lover of music."—SATURDAY REVIEW.
- Huxley.**—INTRODUCTORY PRIMER OF SCIENCE. By T. H. HUXLEY, F.R.S., &c. 18mo. 1s.
- Ibbetson.**—THE MATHEMATICAL THEORY OF PERFECTLY ELASTIC SOLIDS, with a Short Account of Viscous Fluids. An Elementary Treatise. By WILLIAM JOHN IBBETSON, B.A., F.R.A.S., Senior Scholar of Clare College, Cambridge. 8vo. 21s.



- Jones.**—Works by D. E. JONES, B.Sc., Professor of Physics in University College of Wales, Aberystwyth.
- EXAMPLES IN PHYSICS. Fcap. 8vo. 3s. 6d.
- SOUND, LIGHT, AND HEAT. An Elementary Text-book. With Illustrations. Fcap. 8vo. [In the press.]
- Kempe.**—HOW TO DRAW A STRAIGHT LINE; a Lecture on Linkages. By A. B. KEMPE. With Illustrations. Crown 8vo. 1s. 6d. (*Nature Series.*)
- Kennedy.**—THE MECHANICS OF MACHINERY. By A. B. W. KENNEDY, F.R.S., M.Inst.C.E., late Professor of Engineering and Mechanical Technology in University College, London. With numerous Illustrations. Crown 8vo. 12s. 6d.
- Lang.**—EXPERIMENTAL PHYSICS. By P. R. SCOTT LANG, M.A., Professor of Mathematics in the University of St. Andrews. With Illustrations. Crown 8vo. [In the press.]
- Lock.**—Works by Rev. J. B. LOCK, M.A., Senior Fellow, Assistant Tutor and Lecturer in Gonville and Caius College, Cambridge, formerly Master at Eton, &c.
- DYNAMICS FOR BEGINNERS. Second Edition. Globe 8vo. 3s. 6d.
- ELEMENTARY STATICS. Globe 8vo. 4s. 6d.
- Lodge.**—MODERN VIEWS OF ELECTRICITY. By OLIVER J. LODGE, LL.D., D.Sc., F.R.S., Professor of Experimental Physics in University College, Liverpool. Illustrated. Crown 8vo. 6s. 6d. (*Nature Series.*)
- Loewy.**—QUESTIONS AND EXAMPLES ON EXPERIMENTAL PHYSICS: Sound, Light, Heat, Electricity, and Magnetism. By B. LOEWY, F.R.A.S., Science Master at the London International College, and Examiner in Experimental Physics to the College of Preceptors. Fcap. 8vo. 2s.
- A GRADUATED COURSE OF NATURAL SCIENCE FOR ELEMENTARY AND TECHNICAL SCHOOLS AND COLLEGES. By the Same. In Three Parts. Part I. FIRST YEAR'S COURSE. Globe 8vo. 2s.
- Lupton.**—NUMERICAL TABLES AND CONSTANTS IN ELEMENTARY SCIENCE. By SYDNEY LUPTON, M.A., F.C.S., F.I.C., Assistant Master at Harrow School. Extra fcap. 8vo. 2s. 6d.
- Macfarlane.**—PHYSICAL ARITHMETIC. By ALEXANDER MACFARLANE, D.Sc., Examiner in Mathematics in the University of Edinburgh. Crown 8vo. 7s. 6d.
- Macgregor.**—KINEMATICS AND DYNAMICS. An Elementary Treatise. By JAMES GORDON MACGREGOR, M.A., D. Sc., Fellow of the Royal Societies of Edinburgh and of Canada, Munro Professor of Physics in Dalhousie College, Halifax, Nova Scotia, With Illustrations. Crown 8vo. 10s. 6d.

**Mayer.**—SOUND: a Series of Simple, Entertaining, and Inexpensive Experiments in the Phenomena of Sound, for the Use of Students of every age. By A. M. MAYER, Professor of Physics in the Stevens Institute of Technology, &c. With numerous Illustrations. Crown 8vo. 3s. 6d. (*Nature Series.*)

**Mayer and Barnard.**—LIGHT: a Series of Simple, Entertaining, and Inexpensive Experiments in the Phenomena of Light, for the Use of Students of every age. By A. M. MAYER and C. BARNARD. With numerous Illustrations. Crown 8vo. 2s. 6d. (*Nature Series.*)

**Newton.**—PRINCIPIA. Edited by Professor Sir W. THOMSON and Professor BLACKBURNE. 4to. 31s. 6d.

THE FIRST THREE SECTIONS OF NEWTON'S PRINCIPIA. With Notes and Illustrations. Also a Collection of Problems, principally intended as Examples of Newton's Methods. By PERCIVAL FROST, M.A. Third Edition. 8vo. 12s.

**Parkinson.**—A TREATISE ON OPTICS. By S. PARKINSON, D.D., F.R.S., Tutor and Prælector of St. John's College, Cambridge. Fourth Edition, revised and enlarged. Crown 8vo. 10s. 6d.

**Peabody.**—THERMODYNAMICS OF THE STEAM ENGINE AND OTHER HEAT-ENGINES. By CECIL H. PEABODY, Associate Professor of Steam Engineering, Massachusetts Institute of Technology. 8vo. *[In the press.]*

**Perry.**—STEAM. AN ELEMENTARY TREATISE. By JOHN PERRY, C.E., Whitworth Scholar, Fellow of the Chemical Society, Professor of Mechanical Engineering and Applied Mechanics at the Technical College, Finsbury. With numerous Woodcuts and Numerical Examples and Exercises. 1890. 4s. 6d.

**Rayleigh.**—THE THEORY OF SOUND. By LORD RAYLEIGH, M.A., F.R.S., formerly Fellow of Trinity College, Cambridge, 8vo. Vol. I. 12s. 6d. Vol. II. 12s. 6d. *[Vol. III. in the press.]*

**Reuleaux.**—THE KINEMATICS OF MACHINERY. Outlines of a Theory of Machines. By Professor F. REULEAUX. Translated and Edited by Professor A. B. W. KENNEDY, F.R.S., C.E. With 450 Illustrations. Medium 8vo. 21s.

**Roscoe and Schuster.**—SPECTRUM ANALYSIS. Lectures delivered in 1868 before the Society of Apothecaries of London. By Sir HENRY E. ROSCOE, LL.D., F.R.S., formerly Professor of Chemistry in the Owens College, Victoria University, Manchester. Fourth Edition, revised and considerably enlarged by the Author and by ARTHUR SCHUSTER, F.R.S., Ph.D., Professor of Applied Mathematics in the Owens College, Victoria University. With Appendices, numerous Illustrations, and Plates. Medium 8vo. 21s.

**Sanderson.**—HYDROSTATICS FOR BEGINNERS. By F. W. SANDERSON, M.A., late Fellow of the University of Durham, and Scholar of Christ's College, Cambridge; Assistant Master in Dulwich College. Globe 8vo. *[In the press.]*

**Shann.**—AN ELEMENTARY TREATISE ON HEAT, IN RELATION TO STEAM AND THE STEAM-ENGINE. By G. SHANN, M.A. With Illustrations. Crown 8vo. 4s. 6d.

**Spottiswoode.**—POLARISATION OF LIGHT. By the late W. SPOTTISWOODE, F.R.S. With Illustrations. New Edition. Crown 8vo. 3s. 6d. (*Nature Series.*)

**Stewart (Balfour).**—Works by BALFOUR STEWART, F.R.S., late Langworthy Professor of Physics in the Owens College, Victoria University, Manchester.

PRIMER OF PHYSICS. With numerous Illustrations. New Edition, with Questions. 18mo. 1s. (*Science Primers.*)

LESSONS IN ELEMENTARY PHYSICS. With numerous Illustrations and Chromoliths of the Spectra of the Sun, Stars, and Nebulæ. New and Enlarged Edition. Fcap. 8vo. 4s. 6d.

QUESTIONS ON BALFOUR STEWART'S ELEMENTARY LESSONS IN PHYSICS. By Prof. THOMAS H. CORE, Owens College, Manchester. New Edition. Fcap. 8vo. 2s.

**Stewart and Gee.**—ELEMENTARY PRACTICAL PHYSICS, LESSONS IN. By BALFOUR STEWART, F.R.S., and W. W. HALDANE GEE, B.Sc. Crown 8vo.

Vol. I.—GENERAL PHYSICAL PROCESSES. 6s.

Vol. II.—ELECTRICITY AND MAGNETISM. 7s. 6d.

Vol. III.—OPTICS, HEAT, AND SOUND. [*In the press.*]

PRACTICAL PHYSICS FOR SCHOOLS AND THE JUNIOR STUDENTS OF COLLEGES. By the same Authors. Globe 8vo.

Vol. I.—ELECTRICITY AND MAGNETISM. 2s. 6d.

**Stokes.**—ON LIGHT. Being the Burnett Lectures, delivered in Aberdeen in 1883, 1884, 1885. By Sir GEORGE GABRIEL STOKES, M.A., P.R.S., &c., Fellow of Pembroke College, and Lucasian Professor of Mathematics in the University of Cambridge. First Course: ON THE NATURE OF LIGHT.—Second Course: ON LIGHT AS A MEANS OF INVESTIGATION.—Third Course: ON THE BENEFICIAL EFFECTS OF LIGHT. Complete in one volume. Crown 8vo. 7s. 6d. (*Nature Series.*)

\* \* The Second and Third Courses may be had separately. Crown 8vo. 2s. 6d. each.

**Stone.**—AN ELEMENTARY TREATISE ON SOUND. By W. H. STONE, M.D. With Illustrations. 18mo. 3s. 6d.

**Tait.**—HEAT. By P. G. TAIT, M.A., Sec. R.S.E., formerly Fellow of St. Peter's College, Cambridge, Professor of Natural Philosophy in the University of Edinburgh. Crown 8vo. 6s.

**Thompson.**—ELEMENTARY LESSONS IN ELECTRICITY AND MAGNETISM. By SILVANUS P. THOMPSON, Principal and Professor of Physics in the Technical College, Finsbury. With Illustrations. New Edition, Revised. Forty-Third Thousand. Fcap. 8vo. 4s. 6d.

**Thomson, Sir W.**—Works by Sir WILLIAM THOMSON, D.C.L., LL.D., F.R.S., F.R.S.E., Fellow of St. Peter's College, Cambridge, and Professor of Natural Philosophy in the University of Glasgow.

ELECTROSTATICS AND MAGNETISM, REPRINTS OF PAPERS ON. Second Edition. Medium 8vo. 18s.

**Thomson.**—POPULAR LECTURES AND ADDRESSES.  
3 vols. With Illustrations. Crown 8vo. Vol. I. Constitution of Matter. 6s. (*Nature Series.*)

**Thomson, J. J.**—Works by J. J. THOMSON, Fellow of Trinity College, Cavendish Professor of Experimental Physics in the University.

THE MOTION OF VORTEX RINGS, A TREATISE ON.  
An Essay to which the Adams Prize was adjudged in 1882 in the University of Cambridge. With Diagrams. 8vo. 6s.

APPLICATIONS OF DYNAMICS TO PHYSICS AND CHEMISTRY. Crown 8vo. 7s. 6d.

**Todhunter.**—NATURAL PHILOSOPHY FOR BEGINNERS.

By I. TODHUNTER, M.A., F.R.S., D.Sc.

Part I. The Properties of Solid and Fluid Bodies. 18mo. 3s. 6d.

Part II. Sound, Light, and Heat. 18mo. 3s. 6d.

**Turner.**—HEAT AND ELECTRICITY, A COLLECTION OF EXAMPLES ON. By H. H. TURNER, B.A., Fellow of Trinity College, Cambridge. Crown 8vo. 2s. 6d.

**Wright (Lewis).**—LIGHT; A COURSE OF EXPERIMENTAL OPTICS, CHIEFLY WITH THE LANTERN. By LEWIS WRIGHT. With nearly 200 Engravings and Coloured Plates. Crown 8vo. 7s. 6d.

## ASTRONOMY.

**Airy.**—POPULAR ASTRONOMY. With Illustrations by Sir G. B. AIRY, K.C.B., formerly Astronomer-Royal. New Edition. 18mo. 4s. 6d.

**Forbes.**—TRANSIT OF VENUS. By G. FORBES, M.A., Professor of Natural Philosophy in the Andersonian University, Glasgow. Illustrated. Crown 8vo. 3s. 6d. (*Nature Series.*)

**Godfray.**—Works by HUGH GODFRAY, M.A., Mathematical Lecturer at Pembroke College, Cambridge.

A TREATISE ON ASTRONOMY, for the Use of Colleges and Schools. Fourth Edition. 8vo. 12s. 6d.

AN ELEMENTARY TREATISE ON THE LUNAR THEORY, with a Brief Sketch of the Problem up to the time of Newton. Second Edition, revised. Crown 8vo. 5s. 6d.

**Lockyer.**—Works by J. NORMAN LOCKYER, F.R.S.

PRIMER OF ASTRONOMY. With numerous Illustrations. New Edition. 18mo. 1s. (*Science Primers.*)

ELEMENTARY LESSONS IN ASTRONOMY. With Coloured Diagram of the Spectra of the Sun, Stars, and Nebulae, and numerous Illustrations. New Edition (36th thousand), revised throughout. Fcap. 8vo. 5s. 6d.

QUESTIONS ON LOCKYER'S ELEMENTARY LESSONS IN ASTRONOMY. For the Use of Schools. By JOHN FORBES-ROBERTSON. 18mo, cloth limp. 1s. 6d.

THE CHEMISTRY OF THE SUN. With Illustrations. 8vo. 14s.

**Lockyer.**—THE METEORIC HYPOTHESIS. With Illustrations. 8vo. [In the press.]

THE EVOLUTION OF THE HEAVENS AND THE EARTH. Crown 8vo. With Illustrations. [In the press.]

**Newcomb.**—POPULAR ASTRONOMY. By S. NEWCOMB, LL.D., Professor U.S. Naval Observatory. With 112 Illustrations and 5 Maps of the Stars. Second Edition, revised. 8vo. 18s.

"It is unlike anything else of its kind, and will be of more use in circulating a knowledge of Astronomy than nine-tenths of the books which have appeared on the subject of late years."—SATURDAY REVIEW.

## CHEMISTRY.

**Armstrong.**—A MANUAL OF INORGANIC CHEMISTRY. By HENRY ARMSTRONG, Ph.D., F.R.S., Professor of Chemistry in the City and Guilds of London Technical Institute. Crown 8vo. [In preparation.]

**Cohen.**—THE OWENS COLLEGE COURSE OF PRACTICAL ORGANIC CHEMISTRY. By JULIUS B. COHEN, Ph.D., F.C.S., Assistant Lecturer on Chemistry in the Owens College, Manchester. With a Preface by SIR HENRY ROSCOE, F.R.S., and C. SCHORLEMMER, F.R.S. Fcap. 8vo. 2s. 6d.

**Cooke.**—ELEMENTS OF CHEMICAL PHYSICS. By JOSIAH P. COOKE, Junr., Erving Professor of Chemistry and Mineralogy in Harvard University. Fourth Edition. Royal 8vo. 21s.

**Fleischer.**—A SYSTEM OF VOLUMETRIC ANALYSIS. By EMIL FLEISCHER. Translated, with Notes and Additions, from the Second German Edition by M. M. PATTISON MUIR, F.R.S.E. With Illustrations. Crown 8vo. 7s. 6d.

**Frankland.**—AGRICULTURAL CHEMICAL ANALYSIS A Handbook of. By PERCY FARADAY FRANKLAND, Ph.D., B.Sc., F.C.S. Associate of the Royal School of Mines, and Demonstrator of Practical and Agricultural Chemistry in the Normal School of Science and Royal School of Mines, South Kensington Museum. Founded upon *Leitfaden für die Agriculture Chemische Analyse*, von Dr. F. KROCKER. Crown 8vo. 7s. 6d.

**Hartley.**—A COURSE OF QUANTITATIVE ANALYSIS FOR STUDENTS. By W. NOEL HARTLEY, F.R.S., Professor of Chemistry, and of Applied Chemistry, Science and Art Department, Royal College of Science, Dublin. Globe 8vo. 5s.

**Hiorns.**—Works by ARTHUR H. HIORNS, Principal of the School of Metallurgy, Birmingham and Midland Institute.

PRACTICAL METALLURGY AND ASSAYING. A Text-Book for the use of Teachers, Students, and Assayers. With Illustrations. Globe 8vo. 6s.

A TEXT-BOOK OF ELEMENTARY METALLURGY FOR THE USE OF STUDENTS. To which is added an Appendix of Examination Questions, embracing the whole of the Questions set in the three stages of the subject by the Science and Art Department for the past twenty years. Globe 8vo. 4s.

- Horns.**—IRON AND STEEL MANUFACTURE. A Text-Book for Beginners. Illustrated. Globe 8vo. 3s. 6d.
- Jones.**—Works by FRANCIS JONES, F.R.S.E., F.C.S., Chemical Master in the Grammar School, Manchester.
- THE OWENS COLLEGE JUNIOR COURSE OF PRACTICAL CHEMISTRY.** With Preface by Sir HENRY ROSCOE, F.R.S., and Illustrations. New Edition. 18mo. 2s. 6d.
- QUESTIONS ON CHEMISTRY.** A Series of Problems and Exercises in Inorganic and Organic Chemistry. Fcap. 8vo. 3s.
- Landauer.**—BLOWPIPE ANALYSIS. By J. LANDAUER. Authorised English Edition by J. TAYLOR and W. E. KAY, of Owens College, Manchester. [New Edition in preparation.]
- Lupton.**—CHEMICAL ARITHMETIC. With 1,200 Problems. By SYDNEY LUPTON, M.A., F.C.S., F.I.C., formerly Assistant Master at Harrow. Second Edition, Revised and Abridged. Fcap. 8vo. 4s. 6d.
- Meldola.**—THE CHEMISTRY OF PHOTOGRAPHY. By RAPHAEL MELDOLA, F.R.S., Professor of Chemistry in the Technical College, Finsbury, City and Guilds of London Institute for the Advancement of Technical Education. Crown 8vo. 6s. (*Nature Series*.)
- Meyer.**—HISTORY OF CHEMISTRY. By ERNST VON MEYER. Translated by GEORGE MCGOWAN. 8vo. [17 1/2 pp.]
- Mixter.**—AN ELEMENTARY TEXT-BOOK OF CHEMISTRY. By WILLIAM G. MIXTER, Professor of Chemistry in the Sheffield Scientific School of Yale College. Second and Revised Edition. Crown 8vo. 7s. 6d.
- Muir.**—PRACTICAL CHEMISTRY FOR MEDICAL STUDENTS. Specially arranged for the first M.B. Course. By M. M. PATTISON MUIR, F.R.S.E. Fcap. 8vo. 1s. 6d.
- Muir and Wilson.**—THE ELEMENTS OF THERMAL CHEMISTRY. By M. M. PATTISON MUIR, M.A., F.R.S.E., Fellow and Prælector of Chemistry in Gonville and Caius College, Cambridge; Assisted by DAVID MUIR WILSON. 8vo. 12s. 6d.
- Ramsay.**—EXPERIMENTAL PROOFS OF CHEMICAL THEORY FOR BEGINNERS. By WILLIAM RAMSAY, PH.D., Professor of Chemistry in University Coll., Bristol. Post 8vo. 2s. 6d.
- Remsen.**—Works by IRA REMSEN, Professor of Chemistry in the Johns Hopkins University.
- COMPOUNDS OF CARBON; or, Organic Chemistry, an Introduction to the Study of. Crown 8vo. 6s. 6d.
- AN INTRODUCTION TO THE STUDY OF CHEMISTRY (INORGANIC CHEMISTRY). Crown 8vo. 6s. 6d.
- THE ELEMENTS OF CHEMISTRY. A Text Book for Beginners. Fcap. 8vo. 2s. 6d.
- A TEXT-BOOK OF INORGANIC CHEMISTRY. Medium 8vo. 16s.
- Roscoe.**—Works by Sir HENRY E. ROSCOE, F.R.S., formerly Professor of Chemistry in the Victoria University the Owens College, Manchester.

- Roscoe.**—PRIMER OF CHEMISTRY. With numerous Illustrations. New Edition. With Questions. 18mo. 1s. (*Science Primers.*)
- LESSONS IN ELEMENTARY CHEMISTRY, INORGANIC AND ORGANIC.** With numerous Illustrations and Chromolitho of the Solar Spectrum, and of the Alkalies and Alkaline Earths. New Edition. Fcap. 8vo. 4s. 6d. (*See under THORPE.*)
- Roscoe and Schorlemmer.**—INORGANIC AND ORGANIC CHEMISTRY. A Complete Treatise on Inorganic and Organic Chemistry. By Sir HENRY E. ROSCOE, F.R.S., and Prof. C. SCHORLEMMER, F.R.S. With Illustrations. Medium 8vo.
- Vols. I. and II.—INORGANIC CHEMISTRY.
- Vol. I.—The Non-Metallic Elements. Second Edition, revised. 21s. Vol. II. Part I.—Metals. 18s. Vol. II. Part II.—Metals. New and thoroughly Revised Edition. 18s.
- Vol. III.—ORGANIC CHEMISTRY.
- THE CHEMISTRY OF THE HYDROCARBONS and their Derivatives, or ORGANIC CHEMISTRY. With numerous Illustrations. Five Parts. Parts I., II., and IV. 21s. each. Parts III. and V. 18s. each.
- Thorpe.**—A SERIES OF CHEMICAL PROBLEMS, prepared with Special Reference to Sir H. E. Roscoe's Lessons in Elementary Chemistry, by T. E. THORPE, Ph.D., F.R.S., Professor of Chemistry in the Normal School of Science, South Kensington, adapted for the Preparation of Students for the Government, Science, and Society of Arts Examinations. With a Preface by Sir HENRY E. ROSCOE, F.R.S. New Edition, with Key. 18mo. 2s.
- Thorpe and Rücker.**—A TREATISE ON CHEMICAL PHYSICS. By T. E. THORPE, Ph.D., F.R.S. Professor of Chemistry in the Normal School of Science, and Professor A. W. RÜCKER. Illustrated. 8vo. [*In preparation.*]
- Wright.**—METALS AND THEIR CHIEF INDUSTRIAL APPLICATIONS. By C. ALDER WRIGHT, D.Sc., &c., Lecturer on Chemistry in St. Mary's Hospital Medical School. Extra fcap. 8vo. 3s. 6d.

## BIOLOGY.

- Allen.**—ON THE COLOUR OF FLOWERS, as Illustrated in the British Flora. By GRANT ALLEN. With Illustrations. Crown 8vo. 3s. 6d. (*Nature Series.*)
- Balfour.**—A TREATISE ON COMPARATIVE EMBRYOLOGY. By F. M. BALFOUR, M.A., F.R.S., Fellow and Lecturer of Trinity College, Cambridge. With Illustrations. Second Edition, reprinted without alteration from the First Edition. In 2 vols. 8vo. Vol. I. 18s. Vol. II. 21s.
- Balfour and Ward.**—A GENERAL TEXT BOOK OF BOTANY. By ISAAC BAYLEY BALFOUR, F.R.S., Professor of Botany in the University of Edinburgh, and H. MARSHALL WARD, F.R.S., Fellow of Christ's College, Cambridge, and Professor of Botany in the Royal Indian Engineering College, Cooper's Hill. 8vo. [*In preparation.*]

**Bettany.**—FIRST LESSONS IN PRACTICAL BOTANY. By G. T. BETTANY, M.A., F.L.S., formerly Lecturer in Botany at Guy's Hospital Medical School. 18mo. 1s.

**Bower.**—A COURSE OF PRACTICAL INSTRUCTION IN BOTANY. By F. O. BOWER, D.Sc., F.L.S., Regius Professor of Botany in the University of Glasgow. Crown 8vo. 10s. 6d.

**Darwin (Charles).**—MEMORIAL NOTICES OF CHARLES DARWIN, F.R.S., &c. By THOMAS HENRY HUXLEY, F.R.S., G. J. ROMANES, F.R.S., ARCHIBALD GEIKIE, F.R.S., and W. T. THISELTON DYER, F.R.S. Reprinted from *Nature*. With a Portrait, engraved by C. H. JEENS. Crown 8vo. 2s. 6d. (*Nature Series*.)

**Eimer.**—EVOLUTION. By Prof. EIMER. Translated by J. T. CUNNINGHAM. 8vo. [*In preparation*.]

**Fearnley.**—A MANUAL OF ELEMENTARY PRACTICAL HISTOLOGY. By WILLIAM FEARNLEY. With Illustrations. Crown 8vo. 7s. 6d.

**Flower and Gadow.**—AN INTRODUCTION TO THE OSTEOLOGY OF THE MAMMALIA. By WILLIAM HENRY FLOWER, LL.D., F.R.S., Director of the Natural History Departments of the British Museum, late Hunterian Professor of Comparative Anatomy and Physiology in the Royal College of Surgeons of England. With numerous Illustrations. Third Edition. Revised with the assistance of HANS GADOW, Ph.D., M.A., Lecturer on the Advanced Morphology of Vertebrates and Strickland Curator in the University of Cambridge. Crown 8vo. 10s. 6d.

**Foster.**—Works by MICHAEL FOSTER, M.D., Sec. R.S., Professor of Physiology in the University of Cambridge.

PRIMER OF PHYSIOLOGY. With numerous Illustrations. New Edition. 18mo. 1s.

A TEXT-BOOK OF PHYSIOLOGY. With Illustrations. Fifth Edition, largely revised. In Three Parts. Part I., comprising Book I. Blood—The Tissues of Movement, The Vascular Mechanism. 10s. 6d.

Parts II. and III. are in the press preparing for early publication.

**Foster and Balfour.**—THE ELEMENTS OF EMBRYOLOGY. By MICHAEL FOSTER, M.A., M.D., LL.D., Sec. R.S., Professor of Physiology in the University of Cambridge, Fellow of Trinity College, Cambridge, and the late FRANCIS M. BALFOUR, M.A., LL.D., F.R.S., Fellow of Trinity College, Cambridge, and Professor of Animal Morphology in the University. Second Edition, revised. Edited by ADAM SEDGWICK, M.A., Fellow and Assistant Lecturer of Trinity College, Cambridge, and WALTER HEAPE, Demonstrator in the Morphological Laboratory of the University of Cambridge. With Illustrations. Crown 8vo. 10s. 6d.



- Foster and Langley.**—A COURSE OF ELEMENTARY PRACTICAL PHYSIOLOGY AND HISTOLOGY. By Prof. MICHAEL FOSTER, M.D., F.R.S., &c., and J. N. LANGLEY, M.A., F.R.S., Fellow of Trinity College, Cambridge. Sixth Edition. Crown 8vo. 7s. 6d.
- Gamgee.**—A TEXT-BOOK OF THE PHYSIOLOGICAL CHEMISTRY OF THE ANIMAL BODY. Including an Account of the Chemical Changes occurring in Disease. By A. GAMGEE, M.D., F.R.S., formerly Professor of Physiology in the Victoria University the Owens College, Manchester. 2 Vols. 8vo. With Illustrations. Vol. I. 18s. [Vol. II. in the press.]
- Gray.**—STRUCTURAL BOTANY, OR ORGANOGRAPHY ON THE BASIS OF MORPHOLOGY. To which are added the principles of Taxonomy and Phytography, and a Glossary of Botanical Terms. By Professor ASA GRAY, LL.D. 8vo. 10s. 6d.
- Hamilton.**—A SYSTEMATIC AND PRACTICAL TEXT-BOOK OF PATHOLOGY. By D. J. HAMILTON, F.R.C.S.E., F.R.S.E., Professor of Pathological Anatomy, University of Aberdeen. Copiously Illustrated. 8vo. Volume I. 25s.
- Hooker.**—Works by Sir J. D. HOOKER, K.C.S.I., C.B., M.D., F.R.S., D.C.L.
- PRIMER OF BOTANY. With numerous Illustrations. New Edition. 18mo. 1s. (*Science Primers.*)
- THE STUDENT'S FLORA OF THE BRITISH ISLANDS. Third Edition, revised. Globe 8vo. 10s. 6d.
- Howes.**—AN ATLAS OF PRACTICAL ELEMENTARY BIOLOGY. By G. B. HOWES, Assistant Professor of Zoology, Normal School of Science and Royal School of Mines. With a Preface by THOMAS HENRY HUXLEY, F.R.S. Royal 4to. 14s.
- Huxley.**—Works by THOMAS HENRY HUXLEY, F.R.S.
- INTRODUCTORY PRIMER OF SCIENCE. 18mo. 1s. (*Science Primers.*)
- LESSONS IN ELEMENTARY PHYSIOLOGY. With numerous Illustrations. New Edition Revised. Fcap. 8vo. 4s. 6d.
- QUESTIONS ON HUXLEY'S PHYSIOLOGY FOR SCHOOLS. By T. ALCOCK, M.D. New Edition. 18mo. 1s. 6d.
- Huxley and Martin.**—A COURSE OF PRACTICAL INSTRUCTION IN ELEMENTARY BIOLOGY. By T. H. HUXLEY, F.R.S., LL.D., assisted by H. N. MARTIN, M.A., M.B., D.Sc., F.R.S., Fellow of Christ's College, Cambridge. New Edition, revised and extended by G. B. HOWES, Assistant Professor of Zoology, Normal School of Science, and Royal School of Mines, and D. H. SCOTT, M.A., PH.D., Assistant Professor of Botany, Normal School of Science, and Royal School of Mines. New Edition, thoroughly revised. With a Preface by T. H. HUXLEY, F.R.S. Crown 8vo. 10s. 6d.

- Klein.**—MICRO-ORGANISMS AND DISEASE. An Introduction into the Study of Specific Micro-Organisms. By E. KLEIN, M.D., F.R.S., Lecturer on General Anatomy and Physiology in the Medical School of St. Bartholomew's Hospital, Professor of Bacteriology at the College of State Medicine, London. With 121 Illustrations. Third Edition, Revised. Crown 8vo. 6s. 6d.
- THE BACTERIA IN ASIATIC CHOLERA. By the Same. Crown 8vo. 5s.
- Lankester.**—Works by Professor E. RAY LANKESTER, F.R.S.  
A TEXT BOOK OF ZOOLOGY. 8vo. [*In preparation.*]  
DEGENERATION: A CHAPTER IN DARWINISM. Illustrated. Crown 8vo. 2s. 6d. (*Nature Series.*)
- Lubbock.**—Works by SIR JOHN LUBBOCK, M.P., F.R.S., D.C.L.  
THE ORIGIN AND METAMORPHOSES OF INSECTS. With numerous Illustrations. New Edition. Crown 8vo. 3s. 6d. (*Nature Series.*)  
ON BRITISH WILD FLOWERS CONSIDERED IN RELATION TO INSECTS. With numerous Illustrations. New Edition. Crown 8vo. 4s. 6d. (*Nature Series.*)  
FLOWERS, FRUITS, AND LEAVES. With Illustrations. Second Edition. Crown 8vo. 4s. 6d. (*Nature Series.*)
- Martin and Moale.**—ON THE DISSECTION OF VERTEBRATE ANIMALS. By Professor H. N. MARTIN and W. A. MOALE. Crown 8vo. [*In preparation.*]
- Mivart.**—Works by ST. GEORGE MIVART, F.R.S., Lecturer on Comparative Anatomy at St. Mary's Hospital.  
LESSONS IN ELEMENTARY ANATOMY. With upwards of 400 Illustrations. Fcap. 8vo. 6s. 6d.  
THE COMMON FROG. Illustrated. Cr. 8vo. 3s. 6d. (*Nature Series.*)
- Müller.**—THE FERTILISATION OF FLOWERS. By Professor HERMANN MÜLLER. Translated and Edited by D'ARCY W. THOMPSON, B.A., Professor of Biology in University College, Dundee. With a Preface by CHARLES DARWIN, F.R.S. With numerous Illustrations. Medium 8vo. 21s.
- Oliver.**—Works by DANIEL OLIVER, F.R.S., &c., Professor of Botany in University College, London, &c.  
FIRST BOOK OF INDIAN BOTANY. With numerous Illustrations. Extra fcap. 8vo. 6s. 6d.  
LESSONS IN ELEMENTARY BOTANY. With nearly 200 Illustrations. New Edition. Fcap. 8vo. 4s. 6d.
- Parker.**—A COURSE OF INSTRUCTION IN ZOOTOMY (VERTEBRATA). By T. JEFFREY PARKER, B.Sc. London, Professor of Biology in the University of Otago, New Zealand. With Illustrations. Crown 8vo. 8s. 6d.

**Parker.**—LESSONS IN ELEMENTARY BIOLOGY. By the same Author. With Illustrations. 8vo. [In the press.]

**Parker and Bettany.**—THE MORPHOLOGY OF THE SKULL. By Professor W. K. PARKER, F.R.S., and G. T. BETTANY, M.A., F.L.S. Illustrated. Crown 8vo. 10s. 6d.

**Romanes.**—THE SCIENTIFIC EVIDENCES OF ORGANIC EVOLUTION. By GEORGE J. ROMANES, M.A., LL.D., F.R.S., Zoological Secretary of the Linnean Society. Crown 8vo. 2s. 6d. (*Nature Series.*)

**Sedgwick.**—A SUPPLEMENT TO F. M. BALFOUR'S TREATISE ON EMBRYOLOGY. By ADAM SEDGWICK, M.A., F.R.S., Fellow and Lecturer of Trinity College, Cambridge. 8vo. Illustrated. [In preparation.]

**Smith (W. G.).**—DISEASES OF FIELD AND GARDEN CROPS, CHIEFLY SUCH AS ARE CAUSED BY FUNGI. By WORTHINGTON G. SMITH, F.L.S., M.A.I., Member of the Scientific Committee R.H.S. With 143 New Illustrations drawn and engraved from Nature by the Author. Fcap. 8vo. 4s. 6d.

**Stewart—Corry.**—A FLORA OF THE NORTH-EAST OF IRELAND. Including the Phanerogamia, the Cryptogamia Vascularia, and the Muscineae. By SAMUEL ALEXANDER STEWART, Fellow of the Botanical Society of Edinburgh, Curator of the Collections in the Belfast Museum, and Honorary Associate of the Belfast Natural History and Philosophical Society; and the late THOMAS HUGHES CORRY, M.A., F.L.S., F.Z.S., M.R.I.A., F.B.S. Edin., Lecturer on Botany in the University Medical and Science Schools, Cambridge, Assistant Curator of the University Herbarium, &c., &c. Crown 8vo. 5s. 6d.

**Wallace.**—DARWINISM. An Exposition of the Theory of Natural Selection with some of its applications. By ALFRED RUSSEL WALLACE, LL.D., F.L.S., Author of "The Malay Archipelago," "The Geographical Distribution of Animals," "Island Life," &c. Crown 8vo. 9s.

**Ward.**—TIMBER AND SOME OF ITS DISEASES. By H. MARSHALL WARD, M.A., F.R.S., F.L.S., late Fellow of Christ's College, Cambridge; Professor of Botany in the Royal Indian Engineering College, Cooper's Hill. With Illustrations. Crown 8vo. 6s. (*Nature Series.*)

**Wiedersheim (Prof.).**—ELEMENTS OF THE COMPARATIVE ANATOMY OF VERTEBRATES. Adapted from the German of ROBERT WIEDERSHEIM, Professor of Anatomy, and Director of the Institute of Human and Comparative Anatomy in the University of Freiburg-in-Baden, by W. NEWTON PARKER, Professor of Biology in the University College of South Wales and Monmouthshire. With Additions by the Author and Translator. With Two Hundred and Seventy Woodcuts. Medium 8vo. 12s. 6d.

## MEDICINE.

- Brunton.**—Works by T. LAUDER BRUNTON, M.D., D.Sc., F.R.C.P., F.R.S., Assistant Physician and Lecturer on Materia Medica at St. Bartholomew's Hospital; Examiner in Materia Medica in the University of London, in the Victoria University, and in the Royal College of Physicians, London; late Examiner in the University of Edinburgh.
- A TEXT-BOOK OF PHARMACOLOGY, THERAPEUTICS, AND MATERIA MEDICA. Adapted to the United States Pharmacopœia, by FRANCIS H. WILLIAMS, M.D., Boston, Mass. Third Edition. Adapted to the New British Pharmacopœia, 1885. Medium 8vo. 21s.
- TABLES OF MATERIA MEDICA: A Companion to the Materia Medica Museum. With Illustrations. New Edition Enlarged. Cheaper Issue. 8vo. 5s.
- Griffiths.**—LESSONS ON PRESCRIPTIONS AND THE ART OF PRESCRIBING. By W. HANDSEL GRIFFITHS, PH.D., L.R.C.P.E. New Edition. Adapted to the Pharmacopœia, 1885. 18mo. 3s. 6d.
- Hamilton.**—A TEXT-BOOK OF PATHOLOGY, SYSTEMATIC AND PRACTICAL. By D. J. HAMILTON, M.B., F.R.C.S.E., F.R.S.E., Professor of Pathological Anatomy, University of Aberdeen. Copiously Illustrated. Vol. I. 8vo. 25s.
- Klein.**—MICRO-ORGANISMS AND DISEASE. An Introduction into the Study of Specific Micro-Organisms. By E. KLEIN, M.D., F.R.S., Lecturer on General Anatomy and Physiology in the Medical School of St. Bartholomew's Hospital, London. With 121 Illustrations. Third Edition, Revised. Crown 8vo. 6s.
- THE BACTERIA IN ASIATIC CHOLERA. By the Same Author. Crown 8vo. 5s.
- White.**—A TEXT-BOOK OF GENERAL THERAPEUTICS. By W. HALE WHITE, M.D., F.R.C.P., Senior Assistant Physician to and Lecturer in Materia Medica at Guy's Hospital. With Illustrations. Crown 8vo. 8s. 6d.
- Ziegler-Macalister.**—TEXT-BOOK OF PATHOLOGICAL ANATOMY AND PATHOGENESIS. By Professor ERNST ZIEGLER of Tübingen. Translated and Edited for English Students by DONALD MACALISTER, M.A., M.D., B.Sc., F.R.C.P., Fellow and Medical Lecturer of St. John's College, Cambridge, Physician to Addenbrooke's Hospital, and Teacher of Medicine in the University. With numerous Illustrations. Medium 8vo.
- Part I.—GENERAL PATHOLOGICAL ANATOMY. Second Edition. 12s. 6d.
- Part II.—SPECIAL PATHOLOGICAL ANATOMY. Sections I.—VIII. Second Edition. 12s. 6d. Sections IX.—XII. 12s. 6d.

## ANTHROPOLOGY.

**Flower.**—FASHION IN DEFORMITY, as Illustrated in the Customs of Barbarous and Civilised Races. By Professor FLOWER, F.R.S., F.R.C.S. With Illustrations. Crown 8vo. 2s. 6d. (*Nature Series.*)

**Tylor.**—ANTHROPOLOGY. An Introduction to the Study of Man and Civilisation. By E. B. TYLOR, D.C.L., F.R.S. With numerous Illustrations. Crown 8vo. 7s. 6d.

## PHYSICAL GEOGRAPHY &amp; GEOLOGY.

**Blanford.**—THE RUDIMENTS OF PHYSICAL GEOGRAPHY FOR THE USE OF INDIAN SCHOOLS; with a Glossary of Technical Terms employed. By H. F. BLANFORD, F.G.S. New Edition, with Illustrations. Crown 8vo. 2s. 6d.

**Fisher.**—PHYSICS OF THE EARTH'S CRUST. By the Rev. OSMOND FISHER, M.A., F.G.S., Rector of Harlton, Hon. Fellow of King's College, London, and late Fellow and Tutor of Jesus College, Cambridge. Second Edition, altered and enlarged. 8vo. 12s.

**Geikie.**—Works by ARCHIBALD GEIKIE, LL.D., F.R.S., Director-General of the Geological Survey of Great Britain and Ireland, and Director of the Museum of Practical Geology, London, formerly Murchison Professor of Geology and Mineralogy in the University of Edinburgh, &c.

PRIMER OF PHYSICAL GEOGRAPHY. With numerous Illustrations. New Edition. With Questions. 18mo. 1s. (*Science Primers.*)

ELEMENTARY LESSONS IN PHYSICAL GEOGRAPHY. With numerous Illustrations. New Edition. Fcap. 8vo. 4s. 6d.

QUESTIONS ON THE SAME. 1s. 6d.

PRIMER OF GEOLOGY. With numerous Illustrations. New Edition. 18mo. 1s. (*Science Primers.*)

CLASS BOOK OF GEOLOGY. With upwards of 200 New Illustrations. Crown 8vo. 10s. 6d.

TEXT-BOOK OF GEOLOGY. With numerous Illustrations. Second Edition, Seventh Thousand, Revised and Enlarged. 8vo. 28s.

OUTLINES OF FIELD GEOLOGY. With Illustrations. New Edition. Extra fcap. 8vo. 3s. 6d.

THE SCENERY AND GEOLOGY OF SCOTLAND, VIEWED IN CONNEXION WITH ITS PHYSICAL GEOLOGY. With numerous Illustrations. Crown 8vo. 12s. 6d. (See also under *Geography.*)

**Huxley.**—PHYSIOGRAPHY. An Introduction to the Study of Nature. By THOMAS HENRY HUXLEY, F.R.S. With numerous Illustrations, and Coloured Plates. New and Cheaper Edition. Crown 8vo. 6s.

**Lockyer.**—OUTLINES OF PHYSIOGRAPHY—THE MOVEMENTS OF THE EARTH. By J. NORMAN LOCKYER, F.R.S., Correspondent of the Institute of France, Foreign Member of the Academy of the Lyncei of Rome, &c., &c.; Professor of Astronomical Physics in the Normal School of Science, and Examiner in Physiography for the Science and Art Department. With Illustrations. Crown 8vo. Sewed, 1s. 6d.

**Phillips.**—A TREATISE ON ORE DEPOSITS. By J. ARTHUR PHILLIPS, F.R.S., V.P.G.S., F.C.S., M.Inst.C.E., Ancien Élève de l'École des Mines, Paris; Author of "A Manual of Metallurgy," "The Mining and Metallurgy of Gold and Silver," &c. With numerous Illustrations. 8vo. 25s.

**Rosenbusch — Iddings.** — MICROSCOPICAL PHYSIOGRAPHY OF THE ROCK-MAKING MINERALS: AN AID TO THE MICROSCOPICAL STUDY OF ROCKS. By H. ROSENBUSCH. Translated and Abridged for Use in Schools and Colleges. By JOSEPH P. IDDINGS. Illustrated by 121 Woodcuts and 26 Photomicrographs. 8vo, 24s.

## AGRICULTURE.

**Frankland.**—AGRICULTURAL CHEMICAL ANALYSIS, A Handbook of. By PERCY FARADAY FRANKLAND, Ph.D., B.Sc., F.C.S., Associate of the Royal School of Mines, and Demonstrator of Practical and Agricultural Chemistry in the Normal School of Science and Royal School of Mines, South Kensington Museum. Founded upon *Leitfaden für die Agriculture Chemische Analyse*, von Dr. F. KRÖCKER. Crown 8vo. 7s. 6d.

**Smith (Worthington G.).**—DISEASES OF FIELD AND GARDEN CROPS, CHIEFLY SUCH AS ARE CAUSED BY FUNGI. By WORTHINGTON G. SMITH, F.L.S., M.A.I., Member of the Scientific Committee of the R.H.S. With 143 Illustrations, drawn and engraved from Nature by the Author. Fcap. 8vo. 4s. 6d.

**Tanner.**—Works by HENRY TANNER, F.C.S., M.R.A.C., Examiner in the Principles of Agriculture under the Government Department of Science; Director of Education in the Institute of Agriculture, South Kensington, London; sometime Professor of Agricultural Science, University College, Aberystwith.

ELEMENTARY LESSONS IN THE SCIENCE OF AGRICULTURAL PRACTICE. Fcap. 8vo. 3s. 6d.

FIRST PRINCIPLES OF AGRICULTURE. 18mo. 1s.

THE PRINCIPLES OF AGRICULTURE. A Series of Reading Books for use in Elementary Schools. Prepared by HENRY TANNER, F.C.S., M.R.A.C. Extra fcap. 8vo.

I. The Alphabet of the Principles of Agriculture. 6d.

II. Further Steps in the Principles of Agriculture. 1s.

III. Elementary School Readings on the Principles of Agriculture for the third stage. 1s.

**Ward.**—TIMBER AND SOME OF ITS DISEASES. By H. MARSHALL WARD, M.A., F.L.S., F.R.S., Fellow of Christ's College, Cambridge, Professor of Botany at the Royal Indian Engineering College, Copper's Hill. With illustrations, Crown 8vo. 6s. (*Nature Series.*)

## POLITICAL ECONOMY.

**Böhm-Bauerk.**—CAPITAL AND INTEREST. Translated by WILLIAM SMART. 8vo. [*In the press.*]

**Cairnes.**—THE CHARACTER AND LOGICAL METHOD OF POLITICAL ECONOMY. By J. E. CAIRNES, LL.D., Emeritus Professor of Political Economy in University College, London. New Edition. Crown 8vo. 6s.

**Cossa.**—GUIDE TO THE STUDY OF POLITICAL ECONOMY. By Dr. LUIGI COSSA, Professor in the University of Pavia. Translated from the Second Italian Edition. With a Preface by W. STANLEY JEVONS, F.R.S. Crown 8vo. 4s. 6d.

**Donisthorpe.**—INDIVIDUALISM: A System of Politics. By WORDSWORTH DONISTHORPE. 8vo. [*In preparation.*]

**Fawcett (Mrs.).**—Works by MILLICENT GARRETT FAWCETT:—POLITICAL ECONOMY FOR BEGINNERS, WITH QUESTIONS. Fourth Edition. 18mo. 2s. 6d.

TALES IN POLITICAL ECONOMY. Crown 8vo. 3s.

**Fawcett.**—A MANUAL OF POLITICAL ECONOMY. By Right Hon. HENRY FAWCETT, F.R.S. Sixth Edition; revised, with a chapter on "State Socialism and the Nationalisation of the Land," and an Index. Crown 8vo. 12s.

AN EXPLANATORY DIGEST of the above. By CYRIL A. WATERS, B.A. Crown 8vo. 2s. 6d.

**Gunton.**—WEALTH AND PROGRESS: A CRITICAL EXAMINATION OF THE WAGES QUESTION AND ITS ECONOMIC RELATION TO SOCIAL REFORM. By GEORGE GUNTON. Crown 8vo. 6s.

**Jevons.**—Works by W. STANLEY JEVONS, LL.D. (Edinb.), M.A. (Lond.), F.R.S., late Professor of Political Economy in University College, London, Examiner in Mental and Moral Science in the University of London.

PRIMER OF POLITICAL ECONOMY. New Edition. 18mo. 1s. (*Science Primers.*)

THE THEORY OF POLITICAL ECONOMY. Third Edition. Revised. Demy 8vo. 10s. 6d.

**Keynes.**—THE SCOPE AND METHOD OF POLITICAL ECONOMY. By J. N. KEYNES, M.A. [*In preparation.*]

**Marshall.**—THE ECONOMICS OF INDUSTRY. By A. MARSHALL, M.A., Professor of Political Economy in the University of Cambridge, and MARY P. MARSHALL, late Lecturer at Newnham Hall, Cambridge. Extra fcap. 8vo. 2s. 6d.

**Marshall.**—ECONOMICS. By ALFRED MARSHALL, M.A., Professor of Political Economy in the University of Cambridge. 2 vols. 8vo. [*In the press.*]

**Palgrave.**—A DICTIONARY OF POLITICAL ECONOMY. By various Writers. Edited by R. H. INGLIS PALGRAVE. [*In preparation.*]

**Sidgwick.**—THE PRINCIPLES OF POLITICAL ECONOMY. By HENRY SIDGWICK, M.A., LL.D., Knightbridge Professor of Moral Philosophy in the University of Cambridge, &c.; Author of "The Methods of Ethics." Second Edition, revised. 8vo. 16s.

THE ELEMENTS OF POLITICS. By the same Author. 8vo. [*In the press.*]

**Walker.**—Works by FRANCIS A. WALKER, M.A., Ph.D., Author of "Money," "Money in its Relation to Trade," &c.

POLITICAL ECONOMY. Second Edition, revised and enlarged. 8vo. 12s. 6d.

A BRIEF TEXT-BOOK OF POLITICAL ECONOMY. Crown 8vo. 6s. 6d.

THE WAGES QUESTION. 8vo. 14s.

**Wicksteed.**—ALPHABET OF ECONOMIC SCIENCE. By PHILIP H. WICKSTEED, M.A. Part I. Elements of the Theory of Value or Worth. Globe 8vo. 2s. 6d.

## MENTAL & MORAL PHILOSOPHY.

**Boole.**—THE MATHEMATICAL ANALYSIS OF LOGIC. Being an Essay towards a Calculus of Deductive Reasoning. By GEORGE BOOLE. 8vo. Sewed. 5s.

**Calderwood.**—HANDBOOK OF MORAL PHILOSOPHY. By the Rev. HENRY CALDERWOOD, LL.D., Professor of Moral Philosophy, University of Edinburgh. Fourteenth Edition, largely rewritten. Crown 8vo. 6s.

**Clifford.**—SEEING AND THINKING. By the late Professor W. K. CLIFFORD, F.R.S. With Diagrams. Crown 8vo. 3s. 6d. (*Nature Series.*)

**Jardine.**—THE ELEMENTS OF THE PSYCHOLOGY OF COGNITION. By the Rev. ROBERT JARDINE, B.D., D.Sc. (Edin.), Ex-Principal of the General Assembly's College, Calcutta. Third Edition, revised and improved. Crown 8vo. 6s. 6d.

**Jevons.**—Works by the late W. STANLEY JEVONS, LL.D., M.A., F.R.S.

PRIMER OF LOGIC. New Edition. 18mo. 1s. (*Science Primers.*)

ELEMENTARY LESSONS IN LOGIC; Deductive and Inductive, with copious Questions and Examples, and a Vocabulary of Logical Terms. New Edition. Fcap. 8vo. 3s. 6d.

THE PRINCIPLES OF SCIENCE. A Treatise on Logic and Scientific Method. New and Revised Edition. Crown 8vo. 12s. 6d.



**Jevons.**—STUDIES IN DEDUCTIVE LOGIC. Second Edition.

Crown 8vo. 6s.

LOGICAL PAPERS. 8vo.

[In preparation.]

**Kant—Max Müller.**—CRITIQUE OF PURE REASON

By IMMANUEL KANT. In commemoration of the Centenary of its first Publication. Translated into English by F. MAX MÜLLER.

With an Historical Introduction by LUDWIG NOIRÉ. 2 vols. 8vo. 16s. each.

Volume I. HISTORICAL INTRODUCTION, by LUDWIG NOIRÉ; &c., &c.

Volume II. CRITIQUE OF PURE REASON, translated by F. MAX MÜLLER.

For the convenience of students these volumes are now sold separately.

**Kant—Mahaffy and Bernard.**—KANT'S CRITICAL PHILOSOPHY FOR ENGLISH READERS. By J. P.

MAHAFFY, D.D., Fellow and Tutor of Trinity College, Dublin, Professor of Ancient History in the University of Dublin, and JOHN H. BERNARD, B.D., Fellow of Trinity College, Dublin, Archbishop King's Lecturer in Divinity in the University of Dublin. A new and completed Edition in 2 vols. Crown 8vo.

Vol. I. THE KRITIK OF PURE REASON EXPLAINED AND DEFENDED. 7s. 6d.

Vol. II. THE "PROLEGOMENA." Translated with Notes and Appendices. 6s.

**Keynes.**—FORMAL LOGIC, Studies and Exercises in. Including a Generalisation of Logical Processes in their application to Complex Inferences. By JOHN NEVILLE KEYNES, M.A., late Fellow of Pembroke College, Cambridge. Second Edition, Revised and Enlarged. Crown 8vo. 10s. 6d.

**McCosh.**—PSYCHOLOGY. By JAMES MCCOSH, D.D., LL.D., Litt.D. President of Princeton College, Author of "Intuitions of the Mind," "Laws of Discursive Thought," &c. Crown 8vo

I. THE COGNITIVE POWERS. 6s. 6d.

II. THE MOTIVE POWERS. Crown 8vo. 6s. 6d.

FIRST AND FUNDAMENTAL TRUTHS: being a Treatise on Metaphysics By the Same. Extra crown 8vo. 9s.

**Ray.**—A TEXT-BOOK OF DEDUCTIVE LOGIC FOR THE USE OF STUDENTS. By P. K. RAY, D.Sc. (Lon. and Edin.), Professor of Logic and Philosophy, Presidency College Calcutta. Fourth Edition. Globe 8vo. 4s. 6d.

The SCHOOLMASTER says:—"This work . . . is deservedly taking a place among the recognised text-books on Logic."

**Sidgwick.**—Works by HENRY SIDGWICK, M.A., LL.D., Knight-bridge Professor of Moral Philosophy in the University of Cambridge.

THE METHODS OF ETHICS. Third Edition. 8vo. 14s. A Supplement to the Second Edition, containing all the important Additions and Alterations in the Third Edition. Demy 8vo. 6s.

**Sidgwick.**—**OUTLINES OF THE HISTORY OF ETHICS**, for English Readers. Second Edition, revised. Crown 8vo. 3s. 6d.

**ELEMENTS OF POLITICS.** Demy 8vo. [*In the press*]

**Venn.**—Works by JOHN VENN, Sc.D., F.R.S., M.A., Fellow and Lecturer in Moral Sciences in Gonville and Caius College, Cambridge; Examiner in Moral Philosophy in the University of London.

**THE LOGIC OF CHANCE.** An Essay on the Foundations and Province of the Theory of Probability, with special Reference to its Logical Bearings and its Application to Moral and Social Science. Third Edition, rewritten and greatly enlarged. Crown 8vo. 10s. 6d.

**SYMBOLIC LOGIC.** Crown 8vo. 10s. 6d.

**THE PRINCIPLES OF EMPIRICAL OR INDUCTIVE LOGIC.** Medium 8vo. 18s.

## GEOGRAPHY.

**Bartholomew.**—**THE ELEMENTARY SCHOOL ATLAS.**

By JOHN BARTHOLOMEW, F.R.G.S. 4to. 1s.

This Elementary Atlas is designed to illustrate the principal textbooks on Elementary Geography.

**A SCHOOL ATLAS.** By the same Author. 4to. [*In preparation.*]

**Clarke.**—**CLASS-BOOK OF GEOGRAPHY.** By C. B. CLARKE, F.R.S. New Edition, revised 1889, with Eighteen Coloured Maps. Fcap. 8vo. Paper covers, 3s.; cloth, 3s. 6d.

**Geikie.**—Works by ARCHIBALD GEIKIE, F.R.S., Director General of the Geological Survey of the United Kingdom, and Director of the Museum of Practical Geology, Jermyn Street, London; formerly Murchison Professor of Geology and Mineralogy in the University of Edinburgh.

**THE TEACHING OF GEOGRAPHY.** A Practical Handbook for the use of Teachers. Crown 8vo. 2s. Being Volume I. of a New Geographical Series Edited by ARCHIBALD GEIKIE, F.R.S.

\* \* The aim of this volume is to advocate the claims of geography as an educational discipline of a high order, and to show how these claims may be practically recognised by teachers.

**GEOGRAPHY OF THE BRITISH ISLES.** 18mo. 1s.

**Green.**—**A SHORT GEOGRAPHY OF THE BRITISH ISLANDS.** By JOHN RICHARD GREEN and ALICE STOPFORD GREEN. With Maps. Fcap. 8vo. 3s. 6d.

**Grove.**—**A PRIMER OF GEOGRAPHY.** By SIR GEORGE GROVE, D.C.L. With Illustrations. 18mo. 1s. (*Science Primers.*)

**Kiepert.**—**A MANUAL OF ANCIENT GEOGRAPHY.** From the German of Dr. H. KIEPERT. Crown 8vo. 5s.

**Macmillan's Geographical Series.** Edited by ARCHIBALD GEIKIE, F.R.S., Director-General of the Geological Survey of the United Kingdom.

The following List of Volumes is contemplated:—

**THE TEACHING OF GEOGRAPHY.** A Practical Handbook for the use of Teachers. By ARCHIBALD GEIKIE, F.R.S., Director-General of the Geological Survey of the United Kingdom, and Director of the Museum of Practical Geology, Jermyn Street, London; formerly Murchison Professor of Geology and Mineralogy in the University of Edinburgh. Crown 8vo. 2s.

\* \* The aim of this volume is to advocate the claims of geography as an educational discipline of a high order, and to show how these claims may be practically recognized by teachers.

**GEOGRAPHY OF THE BRITISH ISLES.** By ARCHIBALD GEIKIE, F.R.S. 18mo. 1s.

**THE ELEMENTARY SCHOOL ATLAS.** With 24 Maps in Colours, specially designed to illustrate all Elementary Text-books of Geography. By JOHN BARTHOLOMEW, F.R.G.S. 4th. 1s.

**AN ELEMENTARY CLASS-BOOK OF GENERAL GEOGRAPHY.** By HUGH ROBERT MILL, D.Sc. Edin. With Illustrations. Crown 8vo. 3s. 6d.

**GEOGRAPHY OF THE BRITISH COLONIES.** By GEORGE M. DAWSON and ALEXANDER SUTHERLAND. [*In preparation.*]

**GEOGRAPHY OF EUROPE.** By JAMES SIME, M.A. With Illustrations. Globe 8vo. [*In the press.*]

**GEOGRAPHY OF NORTH AMERICA.** By Professor N. S. SHAYLER. [*In preparation.*]

**GEOGRAPHY OF ASIA.**

**GEOGRAPHY OF AFRICA.**

**GEOGRAPHY OF THE OCEANS AND OCEANIC ISLANDS.**

**ADVANCED CLASS-BOOK OF THE GEOGRAPHY OF BRITAIN.**

**GEOGRAPHY OF AUSTRALIA AND NEW ZEALAND.**

**GEOGRAPHY OF AMERICA.**

**GEOGRAPHY OF INDIA.** By H. F. BLANFORD, F.G.S.

**ADVANCED CLASS-BOOK OF THE GEOGRAPHY OF EUROPE.**

**Mill.**—AN ELEMENTARY CLASS-BOOK OF GENERAL GEOGRAPHY. By HUGH ROBERT MILL, D.Sc., F.R.S.E., Lecturer on Physiography and on Commercial Geography in the Heriot-Watt College, Edinburgh. With Illustrations. Crown 8vo. 3s. 6d.

**Sime.**—A GEOGRAPHY OF EUROPE. By JAMES SIME, M.A. With Illustrations. Globe 8vo. [*In the press.*]

**Strachey.**—LECTURES ON GEOGRAPHY. By General R. STRACHEY, R.E., C.S.I., President of the Royal Geographical Society. Crown 8vo. 4s. 6d.

## HISTORY.

**Arnold (T.).**—THE SECOND PUNIC WAR. Being Chapters from THE HISTORY OF ROME. By THOMAS ARNOLD, D.D. Edited, with Notes, by W. T. ARNOLD, M.A. With 8 Maps. Crown 8vo. 8s. 6d.

**Arnold (W. T.).**—THE ROMAN SYSTEM OF PROVINCIAL ADMINISTRATION TO THE ACCESSION OF CONSTANTINE THE GREAT. By W. T. ARNOLD, M.A. Crown 8vo. 6s.  
 "Ought to prove a valuable handbook to the student of Roman history."—  
 GUARDIAN.

**Beesly.**—STORIES FROM THE HISTORY OF ROME. By Mrs. BEESLY. Fcap. 8vo. 2s. 6d.

**Bryce.**—THE HOLY ROMAN EMPIRE. By JAMES BRYCE, D.C.L., Fellow of Oriel College, and Regius Professor of Civil Law in the University of Oxford. Eighth Edition. Crown 8vo. 7s. 6d.  
 \*\* Also a *Library Edition*. Demy 8vo. 14s.

**Buckley.**—A HISTORY OF ENGLAND FOR BEGINNERS. By ARABELLA B. BUCKLEY. Author of "A Short History of Natural Science," &c. With Coloured Maps, Chronological and Genealogical Tables. Globe 8vo. 3s.

**Bury.**—A HISTORY OF THE LATER ROMAN EMPIRE FROM ARCADIUS TO IRENE, A.D. 395-800. By JOHN P. BURY, Fellow of Trinity Coll., Dublin. 2 vols. 8vo. [*In the press.*]

**Eggleston.**—THE HOUSEHOLD HISTORY OF THE UNITED STATES AND ITS PEOPLE. By EDWARD EGGLESTON. With Illustrations. 4to. 12s.

**English Statesmen, Twelve.**—A Series of Short Biographies, not designed to be a complete roll of Famous Statesmen, but to present in historic order the lives and work of those leading actors in our affairs who by their direct influence have left an abiding mark on the policy, the institutions, and the position of Great Britain among States.

The following list of subjects is the result of careful selection. The great movements of national history are made to follow one another in a connected course, and the series is intended to form a continuous narrative of English freedom, order, and power. The volumes as follow, Crown 8vo, 2s. 6d. each, are ready or in preparation:—

- |  |                 |
|--|-----------------|
| WILLIAM THE CONQUEROR. By EDWARD A. FREEMAN, D.C.L., LL.D. | [Ready.]        |
| HENRY II. By Mrs. J. R. GREEN.                             | [Ready.]        |
| EDWARD I. By F. YORK POWELL.                               |                 |
| HENRY VII. By JAMES GAIRDNER.                              | [Ready.]        |
| CARDINAL WOLSEY. By Professor M. CREIGHTON.                | [Ready.]        |
| ELIZABETH. By the DEAN OF ST. PAUL'S.                      |                 |
| OLIVER CROMWELL. By FREDERIC HARRISON.                     | [Ready.]        |
| WILLIAM III. By H. D. TRAILL.                              | [Ready.]        |
| WALPOLE. By JOHN MORLEY.                                   | [In the press.] |

**English Statesmen, Twelve—continued.**

CHATHAM. By JOHN MORLEY.

PITT. By JOHN MORLEY.

PEEL. By J. R. THURSFIELD.

[*In the press.*]

**Fiske.**—Works by JOHN FISKE, formerly Lecturer on Philosophy at Harvard University, author of "Outlines of Cosmic Philosophy, based on the Doctrine of Evolution, with Criticisms on the Positive Philosophy," "Darwinism, and other Essays," "American Political Ideas viewed from the Standpoint of Universal History."

THE CRITICAL PERIOD IN AMERICAN HISTORY, 1783—1789. Extra crown 8vo. 10s. 6d.

THE BEGINNINGS OF NEW ENGLAND; or, The Puritan Theocracy in its Relations to Civil and Religious Liberty. Crown 8vo. 7s. 6d.

**Freeman.**—Works by EDWARD A. FREEMAN, D.C.L., LL.D., Regius Professor of Modern History in the University of Oxford, &c.

OLD ENGLISH HISTORY. With Five Coloured Maps. New Edition. Extra fcap. 8vo. 6s.

A SCHOOL HISTORY OF ROME. Crown 8vo. [*In preparation.*]

METHODS OF HISTORICAL STUDY. A Course of Lectures. 8vo. 10s. 6d.

THE CHIEF PERIODS OF EUROPEAN HISTORY. Six Lectures read in the University of Oxford in Trinity Term, 1885.

With an Essay on Greek Cities under Roman Rule. 8vo. 10s. 6d.

HISTORICAL ESSAYS. First Series. Fourth Edition. 8vo. 10s. 6d.

Contents:—The Mythical and Romantic Elements in Early English History—The Continuity of English History—The Relations between the Crown of England and Scotland—St. Thomas of Canterbury and his Biographers, &c.

HISTORICAL ESSAYS. Second Series. Third Edition, with additional Essays. 8vo. 10s. 6d.

Contents:—Ancient Greece and Mediæval Italy—Mr. Gladstone's Homer and the Homeric Ages—The Hierarchs of Athens—The Athenian Democracy—Alexander the Great—Greece during the Macedonian Period—Mommson's History of Rome—Lucius Cornelius Sulla—The Flavian Cæsars, &c., &c.

HISTORICAL ESSAYS. Third Series. 8vo. 12s.

Contents:—First Impressions of Rome—The Illyrian Emperors and their Land—Augusta Treverorum—The Goths at Ravenna—Race and Language—The Byzantine Empire—First Impressions of Athens—Mediæval and Modern Greece—The Southern Slaves—Sicilian Cycles—The Normans at Palermo.

THE GROWTH OF THE ENGLISH CONSTITUTION FROM THE EARLIEST TIMES. Fourth Edition. Crown 8vo. 5s.

GENERAL SKETCH OF EUROPEAN HISTORY. New Edition. Enlarged, with Maps, &c. 18mo. 3s. 6d. (Vol. I. of Historical Course for Schools.)

EUROPE. 18mo. 1s. (*History Primers.*)

**Fyffe.**—A SCHOOL HISTORY OF GREECE. By C. A. FYFFE, M.A. Crown 8vo. [*In preparation.*]

**Green.**—Works by JOHN RICHARD GREEN, M.A., LL.D., late Honorary Fellow of Jesus College, Oxford.

A SHORT HISTORY OF THE ENGLISH PEOPLE. New and Thoroughly Revised Edition. With Coloured Maps, Genealogical Tables, and Chronological Annals. Crown 8vo. 8s. 6d. 148th Thousand.

Also the same in Four Parts. Parts I., II., and III. ready; Part IV. shortly. With the corresponding portion of Mr. Tait's "Analysis." Crown 8vo. 3s. each. Part I. 607—1265. Part II. 1264—1553. Part III. 1540—1689. Part IV. 1660—1873.

HISTORY OF THE ENGLISH PEOPLE. In four vols. 8vo.

Vol. I.—EARLY ENGLAND, 449—1071—Foreign Kings, 1071—1214—The Charter, 1214—1201—The Parliament, 1307—1461. With eight Coloured Maps. 8vo. 16s.

Vol. II.—THE MONARCHY, 1461—1540—The Reformation, 1540—1603. 8vo. 16s.

Vol. III.—PURITAN ENGLAND, 1603—1660—The Revolution, 1660—1688. With four Maps. 8vo. 16s.

Vol. IV.—The Revolution, 1688—1760—Modern England, 1760—1815. With Maps and Index. 8vo. 16s.

THE MAKING OF ENGLAND. With Maps. 8vo. 16s.

THE CONQUEST OF ENGLAND. With Maps and Portrait. 8vo. 18s.

ANALYSIS OF ENGLISH HISTORY, based on Green's "Short History of the English People." By C. W. A. TAIT, M.A., Assistant-Master, Chifton College. Crown 8vo. 3s. 6d.

READINGS FROM ENGLISH HISTORY. Selected and Edited by JOHN RICHARD GREEN. Three Parts. Globe 8vo. 1s. 6d. each. I. Hengist to Cressy. II. Cressy to Cromwell. III. Cromwell to Balaklava.

**Guest.**—LECTURES ON THE HISTORY OF ENGLAND.

By M. J. GUEST. With Maps. Crown 8vo. 6s.

**Historical Course for Schools**—Edited by EDWARD A. FREEMAN, D.C.L., LL.D., late Fellow of Trinity College, Oxford, Regius Professor of Modern History in the University of Oxford.

I.—GENERAL SKETCH OF EUROPEAN HISTORY. By EDWARD A. FREEMAN, D.C.L. New Edition, revised and enlarged, with Chronological Table, Maps, and Index. 18mo. 3s. 6d.

II.—HISTORY OF ENGLAND. By EDITH THOMPSON. New Ed., revised and enlarged, with Coloured Maps. 18mo. 2s. 6d.

III.—HISTORY OF SCOTLAND. By MARGARET MACARTHUR. New Edition. 18mo. 2s.

IV.—HISTORY OF ITALY. By the Rev. W. HUNT, M.A. New Edition, with Coloured Maps. 18mo. 3s. 6d.

V.—HISTORY OF GERMANY. By J. SIME, M.A. New Edition Revised. 18mo. 3s.

VI.—HISTORY OF AMERICA. By JOHN A. DOYLE. With Maps. 18mo. 4s. 6d.

VII.—EUROPEAN COLONIES. By E. J. PAYNE, M.A. With Maps. 18mo. 4s. 6d.

**Historical Course for Schools—continued.**

VIII.—FRANCE. By CHARLOTTE M. YONGE. With Maps. 18mo. 3s. 6d.

GREECE. By EDWARD A. FREEMAN, D.C.L. [*In preparation.*]

ROME. By EDWARD A. FREEMAN, D.C.L. [*In preparation.*]

**History Primers**—Edited by JOHN RICHARD GREEN, M.A., LL.D., Author of "A Short History of the English People."

ROME. By the Rev. M. CREIGHTON, M.A., Dixie Professor of Ecclesiastical History in the University of Cambridge. With Eleven Maps. 18mo. 1s.

GREECE. By C. A. FYFEE, M.A., Fellow and late Tutor of University College, Oxford. With Five Maps. 18mo. 1s.

EUROPEAN HISTORY. By E. A. FREEMAN, D.C.L., LL.D. With Maps. 18mo. 1s.

GREEK ANTIQUITIES. By the Rev. J. P. MAHAFFY, M.A. Illustrated. 18mo. 1s.

CLASSICAL GEOGRAPHY. By H. F. TOZER, M.A. 18mo. 1s.

GEOGRAPHY. By Sir G. GROVE, D.C.L. Maps. 18mo. 1s.

ROMAN ANTIQUITIES. By Professor WILKINS, Litt.D., LL.D. Illustrated. 18mo. 1s.

FRANCE. By CHARLOTTE M. YONGE. 18mo. 1s.

**Hole.**—A GENEALOGICAL STEMMA OF THE KINGS OF ENGLAND AND FRANCE. By the Rev. C. HOLE. On Sheet. 4s.

**Jennings**—CHRONOLOGICAL TABLES. A synchronistic arrangement of the events of Ancient History (with an Index). By the Rev. ARTHUR C. JENNINGS, Rector of King's Stanley, Gloucestershire, Author of "A Commentary on the Psalms," "Ecclesia Anglicana," "Manual of Church History," &c. 8vo. 5s.

**Labberton.**—NEW HISTORICAL ATLAS AND GENERAL HISTORY. By R. H. LABBERTON, Litt Hum.D. 4to. New Edition Revised and Enlarged. 15s.

**Lethbridge.**—A SHORT MANUAL OF THE HISTORY OF INDIA. With an Account of INDIA AS IT IS. The Soil, Climate, and Productions; the People, their Races, Religions, Public Works, and Industries; the Civil Services, and System of Administration. By Sir ROPER LETHBRIDGE, M.A., C.I.E., late Scholar of Exeter College, Oxford, formerly Principal of Kishnighur College, Bengal, Fellow and sometime Examiner of the Calcutta University. With Maps. Crown 8vo. 5s.

**Mahaffy.**—GREEK LIFE AND THOUGHT FROM THE AGE OF ALEXANDER TO THE ROMAN CONQUEST. By the Rev. J. P. MAHAFFY, M.A., D.D., Fellow of Trinity College, Dublin, Author of "Social Life in Greece from Homer to Menander," "Rambles and Studies in Greece," &c. Crown 8vo. 12s. 6d.

**Michelet.**—A SUMMARY OF MODERN HISTORY. Translated from the French of M. MICHELET, and continued to the Present Time, by M. C. M. SIMPSON. Globe 8vo. 4s. 6d.

- Norgate.**—ENGLAND UNDER THE ANGEVIN KINGS! By KATE NORGATE. With Maps and Plans. 2 vols. 8vo. 32s.
- Otté.**—SCANDINAVIAN HISTORY. By E. C. OTTÉ. With Maps. Globe 8vo. 6s.
- Seeley.**—Works by J. R. SEELEY, M.A., Regius Professor of Modern History in the University of Cambridge.  
 THE EXPANSION OF ENGLAND. Crown 8vo. 4s. 6d.  
 OUR COLONIAL EXPANSION. Extracts from the above. Crown 8vo. Sewed. 1s.
- Tait.**—ANALYSIS OF ENGLISH HISTORY, based on Green's "Short History of the English People." By C. W. A. TAIT, M.A., Assistant-Master, Clifton College. Crown 8vo. 3s. 6d.
- Wheeler.**—A SHORT HISTORY OF INDIA AND OF THE FRONTIER STATES OF AFGHANISTAN, NEPAUL, AND BURMA. By J. TALBOYS WHEELER. With Maps. Crown 8vo. 12s.
- COLLEGE HISTORY OF INDIA, ASIATIC AND EUROPEAN. By the same. With Maps. Crown 8vo. 3s. 6d.
- Yonge (Charlotte M.).**—CAMEOS FROM ENGLISH HISTORY. By CHARLOTTE M. YONGE, Author of "The Heir of Redclyffe." Extra fcap. 8vo. New Edition. 5s. each. (1) FROM ROLLO TO EDWARD II. (2) THE WARS IN FRANCE. (3) THE WARS OF THE ROSES. (4) REFORMATION TIMES. (5) ENGLAND AND SPAIN. (6) FORTY YEARS OF STUART RULE (1603—1643). (7) THE REBELLION AND RESTORATION (1642—1678.) [*Shortly.*]
- EUROPEAN HISTORY. Narrated in a Series of Historical Selections from the Best Authorities. Edited and arranged by E. M. SEWELL and C. M. YONGE. First Series, 1003—1154. New Edition. Crown 8vo. 6s. Second Series, 1088—1228. New Edition. Crown 8vo. 6s.
- THE VICTORIAN HALF CENTURY—A JUBILEE BOOK. With a New Portrait of the Queen. Crown 8vo., paper covers, 1s. Cloth, 1s. 6d.

---

## LAW.

- Anglo-Saxon Law, Essays on.**—Contents: Anglo-Saxon Law Courts, Land and Family Law, and Legal Procedure. Medium 8vo. 18s.
- Ball.**—THE STUDENT'S GUIDE TO THE BAR. By WALTER W. R. BALL, M.A., of the Inner Temple, Barrister-at-Law; Fellow and Assistant Tutor of Trinity College, Cambridge, and Fellow of University College, London. Fourth Edition Revised. Crown 8vo. 2s. 6d.



- Bigelow.**—**HISTORY OF PROCEDURE IN ENGLAND FROM THE NORMAN CONQUEST.** The Norman Period, 1066-1204. By MELVILLE MADISON BIGELOW, Ph.D., Harvard University. Demy 8vo. 16s.
- Bryce.**—**THE AMERICAN COMMONWEALTH.** By JAMES BRYCE, M.P., D.C.L., Regius Professor of Civil Law in the University of Oxford, Author of "The Holy Roman Empire." In Three Volumes. Demy 8vo. 54s. Part I. THE NATIONAL GOVERNMENT. Part II. THE STATE GOVERNMENTS. Part III. THE PARTY SYSTEM. Part IV. PUBLIC OPINION. Part V. ILLUSTRATIONS AND REFLECTIONS. Part VI. SOCIAL INSTITUTIONS.
- Buckland.**—**OUR NATIONAL INSTITUTIONS.** A Short Sketch for Schools. By ANNA BUCKLAND. New Edition. With Glossary. 18mo. 1s.
- Dicey.**—**INTRODUCTION TO THE STUDY OF THE LAW OF THE CONSTITUTION.** By A. V. DICEY, B.C.L., of the Inner Temple; Barrister-at-Law; Vinerian Professor of English Law in the University of Oxford; Fellow of All Souls' College; Hon. LL.D. Glasgow. Third Edition. Demy 8vo. 12s. 6d.
- English Citizen, The.**—A Series of Short Books on his Rights and Responsibilities. Edited by HENRY CRAIK, C.B., M.A. (Oxon.); LL.D. (Glasgow). Crown 8vo. 3s. 6d. each.
- CENTRAL GOVERNMENT.** By H. D. TRAILL, D.C.L., late Fellow of St. John's College, Oxford.
- THE ELECTORATE AND THE LEGISLATURE.** By SPENCER WALPOLE, Author of "The History of England from 1815."
- THE POOR LAW.** By the Rev. T. W. FOWLE, M.A.
- THE NATIONAL BUDGET; THE NATIONAL DEBT; TAXES AND RATES.** By A. J. WILSON.
- THE STATE IN RELATION TO LABOUR.** By W. STANLEY JEVONS, LL.D., F.R.S.
- THE STATE AND THE CHURCH.** By the Hon. ARTHUR ELLIOT, M.P.
- FOREIGN RELATIONS.** By SPENCER WALPOLE.
- THE STATE IN ITS RELATION TO TRADE.** By Sir T. H. FARRER, Bart., Permanent Secretary to the Board of Trade.
- LOCAL GOVERNMENT.** By M. D. CHALMERS, M.A.
- THE STATE IN ITS RELATION TO EDUCATION.** By HENRY CRAIK, C.B., M.A., LL.D.
- THE LAND LAWS.** By Sir F. POLLOCK, Bart. late Fellow of Trinity College, Cambridge, Professor of Jurisprudence in the University of Oxford. &c. Second Edition.
- COLONIES AND DEPENDENCIES.** Part I. INDIA. By J. S. COTTON, M.A. II. THE COLONIES. By E. J. PAYNE, M.A.

**English Citizen, The**—*continued.*

JUSTICE AND POLICE. By F. W. MAITLAND.

THE PUNISHMENT AND PREVENTION OF CRIME. By Colonel Sir EDMUND DU CANE, K.C.B., R.E., Chairman of Commissioners of Prisons, Chairman of Directors of Prisons, Inspector-General of Military Prisons, Surveyor-General of Prisons. \*

**Holmes.**—THE COMMON LAW. By O. W. HOLMES, Jun. Demy 8vo. 12s.**Maitland.**—PLEAS OF THE CROWN FOR THE COUNTY OF GLOUCESTER BEFORE THE ABBOT OF READING AND HIS FELLOW JUSTICES ITINERANT, IN THE FIFTH YEAR OF THE REIGN OF KING HENRY THE THIRD, AND THE YEAR OF GRACE 1221. Edited by F. W. MAITLAND. 8vo. 7s. 6d.(See also under *English Citizen Series.*)**Paterson.**—WORKS BY JAMES PATERSON, Barrister-at-Law.

COMMENTARIES ON THE LIBERTY OF THE SUBJECT, AND THE LAWS OF ENGLAND RELATING TO THE SECURITY OF THE PERSON. Cheaper Issue. Two Vols. Crown 8vo. 21s.

THE LIBERTY OF THE PRESS, SPEECH, AND PUBLIC WORSHIP. Being Commentaries on the Liberty of the Subject and the Laws of England. Crown 8vo. 12s.

**Phillimore.**—PRIVATE LAW AMONG THE ROMANS. From the Pandects. By JOHN GEORGE PHILLIMORE, Q.C. 8vo. 16s.**Pollock.**—ESSAYS IN JURISPRUDENCE AND ETHICS. By Sir FREDERICK POLLOCK, Bart., Barrister-at-Law, M.A., Hon. LL.D. Edin.; Corpus Christi Professor of Jurisprudence in the University of Oxford; late Fellow of Trinity College, Cambridge. 8vo. 10s. 6d.(See also under *English Citizen Series.*)**Richey.**—THE IRISH LAND LAWS. By ALEXANDER G. RICHEY, Q.C., LL.D., Deputy Regius Professor of Feudal English Law in the University of Dublin. Crown 8vo. 3s. 6d.**Stephen.**—Works by Sir J. FITZJAMES STEPHEN, Q.C., K.C.S.I., a Judge of the High Court of Justice, Queen's Bench Division.

A DIGEST OF THE LAW OF EVIDENCE. Fifth Edition, revised and enlarged. Crown 8vo. 6s.

A DIGEST OF THE CRIMINAL LAW: CRIMES AND PUNISHMENTS. Fourth Edition, revised. 8vo. 16s.

A DIGEST OF THE LAW OF CRIMINAL PROCEDURE IN INDICTABLE OFFENCES. By Sir JAMES F. STEPHEN, K.C.S.I., &amp;c., and HERBERT STEPHEN, LL.M., of the Inner Temple, Barrister-at-Law. 8vo. 12s. 6d.

**Stephen.**—*continued.*

A HISTORY OF THE CRIMINAL LAW OF ENGLAND.  
New and Revised Edition. Three Vols. 8vo. 48s.

GENERAL VIEW OF THE CRIMINAL LAW OF ENGLAND.  
Second Edition. 8vo. The first edition of this work was published in 1863. The new edition will be substantially a new work, intended as a text-book on the Criminal Law for University and other Students, adapted to the present day. [*In the press.*]

## MODERN LANGUAGES AND LITERATURE.

(1) English, (2) French, (3) German, (4) Modern Greek, (5) Italian, (6) Spanish.

### ENGLISH.

**Abbott.**—A SHAKESPEARIAN GRAMMAR. An attempt to illustrate some of the Differences between Elizabethan and Modern English. By the Rev. E. A. ABBOTT, D.D., formerly Head Master of the City of London School. New Edition. Extra fcap. 8vo. 6s.

**Bacon.**—ESSAYS. Edited by F. G. SELBY, M.A., Professor of Logic and Moral Philosophy, Deccan College, Poona. Globe 8vo. 3s. 6d.

**Burke.**—REFLECTIONS ON THE FRENCH REVOLUTION. Edited by F. G. SELBY, M.A. Globe 8vo. [*In preparation*]

**Brooke.**—PRIMER OF ENGLISH LITERATURE. By the Rev. STOPFORD A. BROOKE, M.A. 18mo. 1s. (*Literature Primers.*)

**Butler.**—HUDIBRAS. Edited, with Introduction and Notes, by ALFRED MILNES, M.A. Lon., late Student of Lincoln College, Oxford. Extra fcap 8vo. Part I. 3s. 6d. Parts II. and III. 4s. 6d.

**Campbell.**—SELECTIONS. Edited by CECIL M. BARROW M.A., Principal and Professor of English and Classics, Doveton College, Madras. [*In preparation.*]

**Cowper's TASK: AN EPISTLE TO JOSEPH HILL, ESQ.; TIROCINIUM, or a Review of the Schools; and THE HISTORY OF JOHN GILPIN.** Edited, with Notes, by WILLIAM BENHAM, B.D. Globe 8vo. 1s. (*Globe Readings from Standard Authors.*)

**THE TASK.** Edited by F. J. ROWE, M.A., and W. T. WEBB, M.A., Professors of English Literature, Presidency College, Calcutta. [*In preparation.*]

**Dowden.**—SHAKESPEARE. By Professor DOWDEN. 18mo. 1s. (*Literature Primers.*)

**Dryden.**—SELECT PROSE WORKS. Edited, with Introduction and Notes, by Professor C. D. YONGE. Fcap. 8vo. 2s. 6d.

**Gladstone.**—SPELLING REFORM FROM AN EDUCATIONAL POINT OF VIEW. By J. H. GLADSTONE, Ph.D., F.R.S., Member of the School Board for London. New Edition. Crown 8vo. 1s. 6d.

**Globe Readers.** For Standards I.—VI. Edited by A. F. MURISON, Sometime English Master at the Aberdeen Grammar School. With Illustrations. Globe 8vo.

Primer I. (48 pp.)	3d.	Book III. (232 pp.)	1s. 3d.
Primer II. (48 pp.)	3d.	Book IV. (328 pp.)	1s. 9d.
Book I. (96 pp.)	6d.	Book V. (416 pp.)	2s.
Book II. (136 pp.)	9d.	Book VI. (448 pp.)	2s. 6d.

"Among the numerous sets of readers before the public the present series is honourably distinguished by the marked superiority of its materials and the careful ability with which they have been adapted to the growing capacity of the pupils. The plan of the two primers is excellent for facilitating the child's first attempts to read. In the first three following books there is abundance of entertaining reading. . . . Better food for young minds could hardly be found."—THE ATHENÆUM.

\***The Shorter Globe Readers.**—With Illustrations. Globe 8vo.

Primer I. (48 pp.)	3d.	Standard III. (178 pp.)	1s.
Primer II. (48 pp.)	3d.	Standard IV. (182 pp.)	1s.
Standard I. (92 pp.)	6d.	Standard V. (216 pp.)	1s. 3d.
Standard II. (124 pp.)	9d.	Standard VI. (228 pp.)	1s. 6d.

\* This Series has been abridged from "The Globe Readers" to meet the demand for smaller reading books.

**Goldsmith.**—THE TRAVELLER, or a Prospect of Society; and THE DESERTED VILLAGE. By OLIVER GOLDSMITH. With Notes, Philological and Explanatory, by J. W. HALES, M.A. Crown 8vo. 6d.

THE VICAR OF WAKEFIELD. With a Memoir of Goldsmith by Professor MASSON. Globe 8vo. 1s. (*Globe Readings from Standard Authors.*)

SELECT ESSAYS. Edited, with Introduction and Notes, by Professor C. D. YONGE. Fcap. 8vo. 2s. 6d.

THE TRAVELLER AND THE DESERTED VILLAGE. Edited by ARTHUR BARRETT, B.A., Professor of English Literature, Elphinstone College, Bombay. Globe 8vo. 1s. 6d.

THE VICAR OF WAKEFIELD. Edited by HAROLD LITTLEDALE, B.A., Professor of History and English Literature, Baroda College. Globe 8vo. [*In preparation.*]

**Gosse.**—A HISTORY OF EIGHTEENTH CENTURY LITERATURE (1660-1780). By EDMUND GOSSE, M.A., Clark Lecturer in English Literature at Trinity College, Cambridge. Crown 8vo. 7s. 6d.

**Gray.**—POEMS. By JOHN BRADSHAW, LL.D. [*In preparation.*]

**Hales.**—LONGER ENGLISH POEMS, with Notes, Philological and Explanatory, and an Introduction on the Teaching of English, Chiefly for Use in Schools. Edited by J. W. HALES, M.A., Professor of English Literature at King's College, London. New Edition. Extra fcap. 8vo. 4s. 6d.

**Helps.**—ESSAYS WRITTEN IN THE INTERVALS OF BUSINESS. Edited by F. J. ROWE, M.A., and W. T. WEBB, M.A., Professors of English Literature, Presidency College, Calcutta. Globe 8vo. 2s. 6d.

**Johnson's LIVES OF THE POETS.** The Six Chief Lives (Milton, Dryden, Swift, Addison, Pope, Gray), with Macaulay's "Life of Johnson." Edited with Preface and Notes by MATTHEW ARNOLD. New and cheaper edition. Crown 8vo. 4s. 6d.

**Lamb (Charles).**—TALES FROM SHAKESPEARE. Edited, with Preface, by the Rev. CANON AINGER, M.A. Globe 8vo. 2s. (*Globe Readings from Standard Authors.*)

**Literature Primers**—Edited by JOHN RICHARD GREEN, M.A., LL.D., Author of "A Short History of the English People."

ENGLISH COMPOSITION. By Professor NICHOL. 18mo. 1s.

ENGLISH GRAMMAR. By the Rev. R. MORRIS, LL.D., sometime President of the Philological Society. 18mo. 1s.

ENGLISH GRAMMAR EXERCISES. By R. MORRIS, LL.D., and H. C. BOWEN, M.A. 18mo. 1s.

EXERCISES ON MORRIS'S PRIMER OF ENGLISH GRAMMAR. By JOHN WETHERELL, of the Middle School, Liverpool College. 18mo. 1s.

ENGLISH LITERATURE. By STOPFORD BROOKE, M.A. New Edition: 18mo. 1s.

SHAKSPERE. By Professor DOWDEN. 18mo. 1s.

THE CHILDREN'S TREASURY OF LYRICAL POETRY. Selected and arranged with Notes by FRANCIS TURNER PALGRAVE. In Two Parts. 18mo. 1s. each.

PHILOLOGY. By J. PEILE, M.A. 18mo. 1s.

ROMAN LITERATURE. By Professor A. S. WILKINS, Litt. D.L.D. [*In the press.*]

### A History of English Literature in Four Volumes. Crown 8vo.

EARLY ENGLISH LITERATURE. By STOPFORD BROOKE, M.A. [*In preparation.*]

ELIZABETHAN LITERATURE. By GEORGE SAINTSBURY. 7s. 6d.

EIGHTEENTH CENTURY LITERATURE. 1660—1780. By EDMUND GOSSE. M.A. 7s. 6d.

THE MODERN PERIOD. By PROFESSOR E. DOWDEN. [*In prep.*]

**Macmillan's Reading Books.**—Adapted to the English and Scotch Codes. Bound in Cloth.

PRIMER. 18mo. (48 pp.) 2d.

BOOK I. for Standard I. 18mo.

(96 pp.) 4s.

BOOK II. for Standard II. 18mo.

(144 pp.) 5d.

BOOK V. for Standard V. 18mo.

(380 pp.) 1s.

BOOK III. for Standard III. 18mo. (160 pp.) 6d.

BOOK IV. for Standard IV. 18mo. (176 pp.) 8d.

BOOK VI. for Standard VI. Cr. 8vo. (430 pp.) 2s.

Book VI. is fitted for higher Classes, and as an Introduction to English Literature.

## Macmillan's Copy-Books—

Published in two sizes, viz. :—

1. Large Post 4to. Price 4d. each.
2. Post Oblong. Price 2d. each.

1. INITIATORY EXERCISES AND SHORT LETTERS.
2. WORDS CONSISTING OF SHORT LETTERS
- \*3. LONG LETTERS. With Words containing Long Letters—Figures.
- \*4. WORDS CONTAINING LONG LETTERS.
- 4a. PRACTISING AND REVISING COPY-BOOK. For Nos. 1 to 4.
- \*5. CAPITALS AND SHORT HALF-TEXT. Words beginning with a Capital
- \*6. HALF-TEXT, WORDS beginning with Capitals—Figures.
- \*7. SMALL-HAND AND HALF-TEXT. With Capitals and Figures.
- \*8. SMALL-HAND AND HALF-TEXT. With Capitals and Figures.
- 8a. PRACTISING AND REVISING COPY-BOOK. For Nos. 5 to 8.
- \*9. SMALL-HAND SINGLE HEADLINES—Figures.
10. SMALL-HAND SINGLE HEADLINES—Figures.
11. SMALL-HAND DOUBLE HEADLINES—Figures.
12. COMMERCIAL AND ARITHMETICAL EXAMPLES, &c.
- 12a. PRACTISING AND REVISING COPY-BOOK. For Nos. 8 to 12.

\* These numbers may be had with *Goodman's Patent Sliding Copies*. Large Post 4to. Price 6d. each.

**Martin.**—THE POET'S HOUR: Poetry selected and arranged for Children. By FRANCES MARTIN, New Edition. 18mo. 2s. 6d.  
 SPRING-TIME WITH THE POETS: Poetry selected by FRANCES MARTIN. New Edition. 18mo. 3s. 6d.

**Milton.**—By STOPFORD BROOKE, M.A. Fcap. 8vo. 1s. 6d.  
*(Classical Writers Series.)*

**Milton.**—PARADISE LOST. Books I. and II. Edited, with Introduction and Notes, by MICHAEL MACMILLAN, B.A. Oxon, Professor of Logic and Moral Philosophy, Elphinstone College, Bombay. Globe 8vo. 2s. 6d. Book I. separately 1s. 6d.

L'ALLEGRO, IL PENSEROSO, LYCIDAS, ARCADES, SONNETS, &c. Edited by WILLIAM BELL, M.A., Prof. of Philosophy and Logic, Government College, Lahore. Globe 8vo. 2s.

COMUS. By the same Editor.

[*In the press.*]

SAMSON AGONISTES: By H. M. PERCIVAL, M.A., Professor of English Literature, Presidency College, Calcutta.

[*In preparation.*]

**Morley.**—ON THE STUDY OF LITERATURE. The Annual Address to the Students of the London Society for the Extension of University Teaching. Delivered at the Mansion House, February 26, 1887. By JOHN MORLEY. Globe 8vo. Cloth. 1s. 6d.

\* Also a Popular Edition in Pamphlet form for Distribution, price 2d.

APHORISMS. By the same. Being an Address delivered before the Philosophical Society of Edinburgh, November 11, 1887. Globe 8vo. 1s. 6d.

**Morris.**—Works by the Rev. R. MORRIS, LL.D. HISTORICAL OUTLINES OF ENGLISH ACCIDENCE, comprising Chapters on the History and Development of the Language, and on Word-formation. New Edition. Fcap. 8vo. 1s. 6d.

**Morris**—*continued.*

ELEMENTARY LESSONS IN HISTORICAL ENGLISH GRAMMAR, containing Accidence and Word-formation. New Edition. 18mo. 2s. 6d.

PRIMER OF ENGLISH GRAMMAR. 18mo. 1s. (See also *Literature Primers.*)

**Morris and Kellner.**—HISTORICAL OUTLINES OF ENGLISH SYNTAX. By Rev. R. MORRIS and Dr. L. KELLNER. [*In preparation.*]

**Oliphant.**—THE OLD AND MIDDLE ENGLISH. A New Edition of "THE SOURCES OF STANDARD ENGLISH," revised and greatly enlarged. By T. L. KINGTON OLIPHANT. Extra fcap. 8vo. 9s.

THE NEW ENGLISH. By the same Author. 2 vols. Cr. 8vo. 21s.

**Palgrave.**—THE CHILDREN'S TREASURY OF LYRICAL POETRY. Selected and arranged, with Notes, by FRANCIS TURNER PALGRAVE. 18mo. 2s. 6d. Also in Two Parts. 1s. each.

**Patmore.**—THE CHILDREN'S GARLAND FROM THE BEST POETS. Selected and arranged by COVENTRY PATMORE. Globe 8vo. 2s. (*Globe Readings from Standard Authors.*)

**Plutarch.**—Being a Selection from the Lives which Illustrate Shakespeare. North's Translation. Edited, with Introductions, Notes, Index of Names, and Glossarial Index, by the Rev. W. W. SKEAT, M.A. Crown 8vo. 6s.

**Ryland.**—CHRONOLOGICAL OUTLINES OF ENGLISH LITERATURE, by F. RYLAND. [*In the press.*]

**Saintsbury.**—A HISTORY OF ELIZABETHAN LITERATURE. By GEORGE SAINTSBURY. Cr. 8vo. 7s. 6d.

**Scott's (Sir Walter)** LAY OF THE LAST MINSTREL, and THE LADY OF THE LAKE. Edited, with Introduction and Notes, by FRANCIS TURNER PALGRAVE. Globe 8vo. 1s. (*Globe Readings from Standard Authors.*)

MARMION; and THE LORD OF THE ISLES. By the same Editor. Globe 8vo. 1s. (*Globe Readings from Standard Authors.*)

MARMION. Edited, with Introduction and Notes, by MICHAEL MACMILLAN, B.A. Globe 8vo. 3s. 6d.

THE LADY OF THE LAKE. Edited by G. H. STUART, M.A., Professor of English Literature, Presidency College, Madras. Globe 8vo. [*In preparation.*]

THE LAY OF THE LAST MINSTREL. By the same Editor. Globe 8vo. [*In preparation.*]

ROKEBY. By MICHAEL MACMILLAN, B.A. Globe 8vo. 3s. 6d.

**Shakespeare.**—A SHAKESPEARIAN GRAMMAR. By Rev. E. A. ABBOTT, D.D., Head Master of the City of London School. Globe 8vo. 6s.

A SHAKESPEARE MANUAL. By F. G. FLEAY, M.A., late Head Master of Skipton Grammar School. Second Edition. Extra fcap. 8vo. 4s. 6d.

**Shakespeare—continued.**

PRIMER OF SHAKESPEARE. By Professor DOWDEN. 18mo.  
1s. (*Literature Primers.*)

THE TEMPEST. Edited by K. DEIGHTON, late Principal of  
Agra College. Globe 8vo. 1s. 6d.

MUCH ADO ABOUT NOTHING. By the same Editor. Globe  
8vo. 2s.

TWELFTH NIGHT. By the same Editor. [*In the press.*]

THE WINTER'S TALE. By the same Editor. Globe 8vo. 2s. 6d.

KING JOHN. By the same Editor. [*In preparation.*]

HENRY V. By the same Editor. Globe 8vo. 2s.

RICHARD III. Edited by C. H. TAWNEY, M.A., Principal and  
Professor of English Literature, Elphinstone College, Calcutta.  
Globe 8vo. 2s. 6d.

JULIUS CÆSAR. By the same Editor. [*In preparation.*]

OTHELLO. By K. DEIGHTON. Globe 8vo. 2s. 6d.

CYMBELINE. By the same Editor. Globe 8vo. 2s. 6d.

**Sonnenschein and Meiklejohn.**—THE ENGLISH  
METHOD OF TEACHING TO READ. By A. SONNEN-  
SCHEIN and J. M. D. MEIKLEJOHN, M.A. Fcap. 8vo.

COMPRISING :

THE NURSERY BOOK, containing all the Two-Letter Words  
in the Language. 1d. (Also in Large Type on Sheets for  
School Walls. 5s.)

THE FIRST COURSE, consisting of Short Vowels with Single  
Consonants. 6d.

THE SECOND COURSE, with Combinations and Bridges,  
consisting of Short Vowels with Double Consonants. 6d.

THE THIRD AND FOURTH COURSES, consisting of Long  
Vowels, and all the Double Vowels in the Language. 6d.

"These are admirable books, because they are constructed on a principle, and that the  
simplest principle on which it is possible to learn to read English."—SPECTATOR.

**Southey.**—LIFE OF NELSON. Edited by MICHAEL  
MACMILLAN, B.A. [*In preparation.*]

**Taylor.**—WORDS AND PLACES; or, Etymological Illustrations  
of History, Ethnology, and Geography. By the Rev.  
ISAAC TAYLOR, M.A., Litt. D., Hon. LL.D., Canon of York.  
Third and Cheaper Edition, revised and compressed. With Maps.  
Globe 8vo. 6s.

**Tennyson.**—The COLLECTED WORKS OF LORD TENNY-  
SON, Poet Laureate. An Edition for Schools. In Four Parts.  
Crown 8vo. 2s. 6d. each.

SELECTIONS FROM LORD TENNYSON'S POEMS. Edited  
with Notes for the Use of Schools. By the Rev. ALFRED  
AINGER, M.A., LL.D., Canon of Bristol. [*In preparation.*]

SELECT POEMS OF LORD TENNYSON. With Introduction  
and Notes. By F. J. ROWE, M.A., and W. T. WEBB, M.A.,  
Professors of English Literature, Presidency College, Calcutta.  
Globe 8vo. 3s. 6d.

This selection contains:—"Recollections of the Arabian Nights," "The Lady of  
Shalott," "Oenone," "The Lotos Eaters," "Ulysses," "Tithonus," "Morte  
d'Arthur," "Sir Galahad," "Dora," "Ode on the Death of the Duke of  
Wellington," and "The Revenge."



- Thring.**—THE ELEMENTS OF GRAMMAR TAUGHT IN ENGLISH. By EDWARD THRING, M.A., late Head Master of Uppingham. With Questions. Fourth Edition. 18mo. 2s.
- Vaughan (C.M.).**—WORDS FROM THE POETS. By C. M. VAUGHAN. New Edition. 18mo, cloth. 1s.
- Ward.**—THE ENGLISH POETS. Selections, with Critical Introductions by various Writers and a General Introduction by MATTHEW ARNOLD. Edited by T. H. WARD, M.A. 4 Vols. Vol. I. CHAUCER TO DONNE.—Vol. II. BEN JONSON TO DRYDEN.—Vol. III. ADDISON TO BLAKE.—Vol. IV. WORDSWORTH TO ROSSETTI. Crown 8vo. Each 7s. 6d.
- Wetherell.**—EXERCISES ON MORRIS'S PRIMER OF ENGLISH GRAMMAR. By JOHN WETHERELL, M.A. 18mo. 1s. (*Literature Primers.*)
- Woods.**—A FIRST POETRY BOOK. Compiled by M. A. WOODS, Head Mistress of the Clifton High School for Girls. Fcap. 8vo. 2s. 6d.
- A SECOND POETRY BOOK. Compiled by the same. Fcap. 8vo. 4s. 6d.
- A THIRD POETRY BOOK. Compiled by the same. Fcap. 8vo. 4s. 6d.
- Wordsworth.**—SELECTIONS. Edited by WILLIAM WORDSWORTH, B.A., Principal and Professor of History and Political Economy, Elphinstone College, Bombay. [*In preparation.*]
- Yonge (Charlotte M.).**—THE ABRIDGED BOOK OF GOLDEN DEEDS A Reading Book for Schools and general readers. By the Author of "The Heir of Redclyffe." 18mo, cloth. 1s. *Globe Readings Edition.* Globe 8vo. 2s.

## FRENCH.

- Beaumarchais.**—LE BARBIER DE SEVILLE. Edited, with Introduction and Notes, by L. P. BLOUET, Assistant Master in St. Paul's School. Fcap. 8vo. 3s. 6d.
- Bowen.**—FIRST LESSONS IN FRENCH. By H. COURTHOPE BOWEN, M.A., Principal of the Finsbury Training College for Higher and Middle Schools. Extra fcap. 8vo. 1s.
- Breymann.**—Works by HERMANN BREYMANN, Ph.D., Professor of Philology in the University of Munich.
- A FRENCH GRAMMAR BASED ON PHILOLOGICAL PRINCIPLES. Second Edition. Extra fcap. 8vo. 4s. 6d.
- FIRST FRENCH EXERCISE BOOK. Extra fcap. 8vo. 4s. 6d.
- SECOND FRENCH EXERCISE BOOK. Extra fcap. 8vo. 2s. 6d.

**Fasnacht.**—Works by G. EUGÈNE FASNACHT, Author of "Macmillan's Progressive French Course," Editor of "Macmillan's Foreign School Classics," &c.

THE ORGANIC METHOD OF STUDYING LANGUAGES.

Extra fcap. 8vo. I. French. 3s. 6d.

A SYNTHETIC FRENCH GRAMMAR FOR SCHOOLS.

Crown 8vo. 3s. 6d.

GRAMMAR AND GLOSSARY OF THE FRENCH LANGUAGE OF THE SEVENTEENTH CENTURY. Crown

8vo.

[In preparation.]

### Macmillan's Primary Series of French Reading

**Books.**—Edited by G. EUGÈNE FASNACHT, formerly Assistant-Master in Westminster School. With Illustrations. Globe 8vo.

CORNAZ—NOS ENFANTS ET LEURS AMIS. PAR SUZANNE CORNAZ. Edited by EDITH HARVEY. With Notes, Vocabulary, and Exercises. Globe 8vo. 1s. 6d.

DE MAISTRE—LA JEUNE SIBÉRIENNE ET LE LÉPREUX DE LA CITÉ D'AOSTE. Edited, with Introduction, Notes, and Vocabulary. By STEPHANE BARLET, B.Sc. Univ. Gall. and London; Assistant-Master at the Mercers' School, Examiner to the College of Preceptors, the Royal Naval College, &c. 1s. 6d.

FLORIAN—FABLES. Selected and Edited, with Notes, Vocabulary, Dialogues, and Exercises, by the Rev. CHARLES YELD, M.A., Head Master of University School, Nottingham. Illustrated. 1s. 6d.

LA FONTAINE—A SELECTION OF FABLES. Edited, with Introduction, Notes, and Vocabulary, by L. M. MORIARTY, B.A., Professor of French in King's College, London. 2s.

MOLESWORTH.—FRENCH LIFE IN LETTERS. By Mrs. MOLESWORTH. With Notes on Idioms, &c. 1s. 6d.

PERRAULT—CONTES DE FÉES. Edited, with Introduction, Notes, and Vocabulary, by G. E. FASNACHT. New Edition with Exercises. 1s. 6d.

(See also *German Authors*, page 77.)

### Macmillan's Progressive French Course.—By G.

EUGÈNE FASNACHT, formerly Assistant-Master in Westminster School.

I.—FIRST YEAR, containing Easy Lessons on the Regular Accidence. New and thoroughly revised Edition. Extra fcap. 8vo. 1s.

II.—SECOND YEAR, containing an Elementary Grammar with copious Exercises, Notes, and Vocabulary. A new Edition, enlarged and thoroughly revised. Extra fcap. 8vo. 2s.

III.—THIRD YEAR, containing a Systematic Syntax, and Lessons in Composition. Extra fcap. 8vo. 2s. 6d.

THE TEACHER'S COMPANION TO MACMILLAN'S PROGRESSIVE FRENCH COURSE. With Copious Notes, Hints for Different Renderings, Synonyms, Philological Remarks, &c. By G. E. FASNACHT. Globe 8vo. *First Year* 4s. 6d., *Second Year* 4s. 6d., *Third Year* 4s. 6d.

**Macmillan's French Composition.**—By G. E. FASNACHT. Part I. Elementary. Extra Fcap. 8vo. 2s. 6d. [*Ready*  
Part II. Advanced. [*Part II. in the press.*  
**THE TEACHER'S COMPANION TO MACMILLAN'S**  
**COURSE OF FRENCH COMPOSITION.** By G. EUGÈNE  
FASNACHT. First Course. Extra fcap. 8vo. 4s. 6d.

**Macmillan's Progressive French Readers.** By  
G. EUGÈNE FASNACHT.

- I.—FIRST YEAR, containing Tales, Historical Extracts, Letters, Dialogues, Ballads, Nursery Songs, &c., with Two Vocabularies: (1) in the order of subjects; (2) in alphabetical order. A new and thoroughly revised Edition, with Imitative Exercises. Extra fcap. 8vo. 2s. 6d.
- II.—SECOND YEAR, containing Fiction in Prose and Verse, Historical and Descriptive Extracts, Essays, Letters, Dialogues, &c. New Edition, with Imitative Exercises. Extra fcap. 8vo. 2s. 6d.

**Macmillan's Foreign School Classics.** Edited by G.  
EUGÈNE FASNACHT. 18mo.

FRENCH.

CORNEILLE—LE CID. Edited by G. E. FASNACHT. 1s.  
DUMAS—LES DEMOISELLES DE ST. CYR. Edited by  
VICTOR OGER, Lecturer in University College, Liverpool. 1s. 6d.  
LA FONTAINE'S FABLES. Books I.—VI. Edited by L. M.  
MORIARTY, B.A., Professor of French in King's College, London.  
[*In preparation.*]

MOLIÈRE—L'AVARE. By the same Editor. 1s.

MOLIÈRE—LE BOURGEOIS GENTILHOMME. By the same  
Editor. 1s. 6d.

MOLIÈRE—LES FEMMES SAVANTES. By G. E. FASNACHT.  
1s.

MOLIÈRE—LE MISANTHROPE. By the same Editor. 1s.

MOLIÈRE—LE MÉDECIN MALGRE LUI. By the same  
Editor. 1s.

RACINE—BRITANNICUS. Edited by EUGÈNE PELLISSIER,  
Assistant-Master in Clifton College, and Lecturer in University  
College, Bristol. 2s.

FRENCH READINGS FROM ROMAN HISTORY. Selected  
from Various Authors and Edited by C. COLBECK, M.A., late  
Fellow of Trinity College, Cambridge; Assistant-Master at  
Harrow. 4s. 6d.

SAND, GEORGE—LA MARE AU DIABLE. Edited by W. E.  
RUSSELL, M.A., Assistant-Master in Haileybury College. 1s.

SANDEAU, JULES—MADEMOISELLE DE LA SEIGLIÈRE.  
Edited by H. C. STEEL, Assistant-Master in Winchester College.  
1s. 6d.

THIERS'S HISTORY OF THE EGYPTIAN EXPEDITION.  
Edited by Rev. H. A. BULL, M.A. Assistant-Master in  
Wellington College. [*In preparation.*]

**Macmillan's Foreign School Classics** (*continued*)—

VOLTAIRE—CHARLES XII. Edited by G. E. FASNACHT. 3s. 6d.

\*\* Other volumes to follow.

(See also *German Authors*, page 77.)

**Masson (Gustave).**—A COMPENDIOUS DICTIONARY OF THE FRENCH LANGUAGE (French-English and English-French). Adapted from the Dictionaries of Professor ALFRED ELWALL. Followed by a List of the Principal Diverging Derivations, and preceded by Chronological and Historical Tables. By GUSTAVE MASSON, Assistant-Master and Librarian, Harrow School. New Edition. Crown 8vo. 6s.

**Molière.**—LE MALADE IMAGINAIRE. Edited, with Introduction and Notes, by FRANCIS TARVER, M.A., Assistant-Master at Eton. Fcap. 8vo. 2s. 6d.

(See also *Macmillan's Foreign School Classics*.)

**Pellissier.**—FRENCH ROOTS AND THEIR FAMILIES. A Synthetic Vocabulary, based upon Derivations, for Schools and Candidates for Public Examinations. By EUGÈNE PELLISSIER, M.A., B.Sc., LL.B., Assistant-Master at Clifton College, Lecturer at University College, Bristol. Globe 8vo. 6s.

**GERMAN.**

**Huss.**—A SYSTEM OF ORAL INSTRUCTION IN GERMAN, by means of Progressive Illustrations and Applications of the leading Rules of Grammar. By HERMANN C. O. HUSS, Ph.D. Crown 8vo. 5s.

**Macmillan's Progressive German Course.** By G. EUGÈNE FASNACHT.

PART I.—FIRST YEAR. Easy Lessons and Rules on the Regular Accidence. Extra fcap. 8vo. 1s. 6d.

PART II.—SECOND YEAR. Conversational Lessons in Systematic Accidence and Elementary Syntax. With Philological Illustrations and Etymological Vocabulary. New Edition, enlarged and thoroughly recast. Extra fcap. 8vo. 3s. 6d.

PART III.—THIRD YEAR. *[In preparation.]*

TEACHER'S COMPANION TO MACMILLAN'S PROGRESSIVE GERMAN COURSE. With copious Notes, Hints for Different Renderings, Synonyms, Philological Remarks, &c. By G. E. FASNACHT. Extra Fcap. 8vo. FIRST YEAR. 4s. 6d.

SECOND YEAR. 4s. 6d.

**Macmillan's Progressive German Readers.** By G. E. FASNACHT.

I.—FIRST YEAR, containing an Introduction to the German order of Words, with Copious Examples, extracts from German Authors in Prose and Poetry; Notes, and Vocabulary. Extra Fcap. 8vo., 2s. 6d.

**Macmillan's Primary German Reading Books.**

(See also *French Authors*, page 74.)

GRIMM—KINDER UND HAUSMÄRCHEN. Selected and Edited, with Notes, and Vocabulary, by G. E. FASNACHT. New Edition, with Exercises. 2s. 6d.

HAUFF.—DIE KARAVANE. Edited, with Notes and Vocabulary, by HERMAN HAGER, Ph.D. Lecturer in the Owens College, Manchester. New Edition, with Exercises, arranged by G. E. FASNACHT. 3s.

SCHMIDT, CHR. VON.—H. VON EICHENFELS. Edited, with Notes, Vocabulary, and Exercises, by G. E. Fasnacht.

[*In the press.*]

**Macmillan's Foreign School Classics.** Edited by G. EUGÈNE FASNACHT, 18mo.

GERMAN.

FREYTAG (G.).—DOKTOR LUTHER. Edited by FRANCIS STORR, M.A., Head Master of the Modern Side, Merchant Taylors' School. [*In preparation.*]

GOETHE—GÖTZ VON BERLICHINGEN. Edited by H. A. BULL, M.A., Assistant Master at Wellington College. 2s.

GOETHE—FAUST. PART I., followed by an Appendix on PART II. Edited by JANE LEE, Lecturer in German Literature at Newnham College, Cambridge. 4s. 6d.

HEINE—SELECTIONS FROM THE REISEBILDER AND OTHER PROSE WORKS. Edited by C. COLBECK, M.A., Assistant-Master at Harrow, late Fellow of Trinity College, Cambridge. 2s. 6d.

LESSING.—MINNA VON BARNHELM. Edited by JAMES SIME, M.A. [*In preparation.*]

SCHILLER—SELECTIONS FROM SCHILLER'S LYRICAL POEMS. Edited, with Notes and a Memoir of Schiller, by E. J. TURNER, B.A., and E. D. A. MORSHEAD, M.A. Assistant-Masters in Winchester College. 2s. 6d.

SCHILLER—DIE JUNGFRAU VON ORLEANS. Edited by JOSEPH GOŠTWICK. 2s. 6d.

SCHILLER—MARIA STUART. Edited by C. SHELDON, M.A., D.Lit., of the Royal Academical Institution, Belfast. 2s. 6d.

SCHILLER—WILHELM TELL. Edited by G. E. FASNACHT. 2s. 6d.

SCHILLER.—WALLENSTEIN. Part I. DAS LAGER. Edited by H. B. COTTERILL, M.A. 2s.

UHLAND—SELECT BALLADS. Adapted as a First Easy Reading Book for Beginners. With Vocabulary. Edited by G. E. FASNACHT. 1s.

\* \* *Other Volumes to follow.*

(See also *French Authors*, page 75.)

**Pylodet.**—NEW GUIDE TO GERMAN CONVERSATION; containing an Alphabetical List of nearly 800 Familiar Words; followed by Exercises; Vocabulary of Words in frequent use; Familiar Phrases and Dialogues; a Sketch of German Literature, Idiomatic Expressions, &c. By L. PYLODET. 18mo, cloth limp. 2s. 6d.

**Whitney.**—Works by W. D. WHITNEY, Professor of Sanskrit and Instructor in Modern Languages in Yale College.

A COMPENDIOUS GERMAN GRAMMAR. Crown 8vo. 4s. 6d.

A GERMAN READER IN PROSE AND VERSE. With Notes and Vocabulary. Crown 8vo. 5s.

**Whitney and Edgren.**—A COMPENDIOUS GERMAN AND ENGLISH DICTIONARY, with Notation of Correspondences and Brief Etymologies. By Professor W. D. WHITNEY, assisted by A. H. EDGREN. Crown 8vo. 7s. 6d.

THE GERMAN-ENGLISH PART, separately, 5s.

### MODERN GREEK.

**Vincent and Dickson.**—HANDBOOK TO MODERN GREEK. By Sir EDGAR VINCENT, K.C.M.G. and T. G. DICKSON, M.A. Second Edition, revised and enlarged, with Appendix on the relation of Modern and Classical Greek by Professor JEBB. Crown 8vo. 6s.

### ITALIAN.

**Dante.**—THE PURGATORY OF DANTE. Edited, with Translation and Notes, by A. J. BUTLER, M.A., late Fellow of Trinity College, Cambridge. Crown 8vo. 12s. 6d.

THE PARADISO OF DANTE. Edited, with Translation and Notes, by the same Author. Crown 8vo. 12s. 6d.

### SPANISH.

**Calderon.**—FOUR PLAYS OF CALDERON. Edited, with Introduction and Notes, by NORMAN MACCOLL, M.A., late Fellow of Downing College, Cambridge. Crown 8vo. 14s.

The four plays here given are *El Principe Constante*, *La Vida es Sueño*, *El Alcalde de Zalamea*, and *El Escondido y La Tapada*.

### DOMESTIC ECONOMY.

**Barker.**—FIRST LESSONS IN THE PRINCIPLES OF COOKING. By LADY BARKER. New Edition. 18mo. 1s.

**Berners.**—FIRST LESSONS ON HEALTH. By J. BERNERS. New Edition. 18mo. 1s.

**Cookery Book.**—THE MIDDLE-CLASS COOKERY BOOK.  
Edited by the Manchester School of Domestic Cookery. Pott 8vo.

[In preparation.]

**Fawcett.**—TALES IN POLITICAL ECONOMY. By MILLICENT GARRETT FAWCETT. Globe 8vo. 3s.

**Frederick.**—HINTS TO HOUSEWIVES ON SEVERAL POINTS, PARTICULARLY ON THE PREPARATION OF ECONOMICAL AND TASTEFUL DISHES. By Mrs. FREDERICK. Crown 8vo. 1s.

"This unpretending and useful little volume distinctly supplies a desideratum . . . The author steadily keeps in view the simple aim of making every-day meals at home, particularly the dinner, attractive, without adding to the ordinary household expenses."—SATURDAY REVIEW.

**Grand'homme.**—CUTTING-OUT AND DRESSMAKING. From the French of Mdle. E. GRAND'HOMME. With Diagrams. 18mo. 1s.

**Jex-Blake.**—THE CARE OF INFANTS. A Manual for Mothers and Nurses. By SOPHIA JEX-BLAKE, M.D., Member of the Irish College of Physicians; Lecturer on Hygiene at the London School of Medicine for Women. 18mo. 1s.

**Tegetmeier.**—HOUSEHOLD MANAGEMENT AND COOKERY. With an Appendix of Recipes used by the Teachers of the National School of Cookery. By W. B. TEGETMEIER. Compiled at the request of the School Board for London. 18mo. 1s.

**Thornton.**—FIRST LESSONS IN BOOK-KEEPING. By J. THORNTON. New Edition. Crown 8vo. 2s. 6d.

The object of this volume is to make the theory of Book-keeping sufficiently plain for even children to understand it.

A KEY TO THE ABOVE FOR THE USE OF TEACHERS AND PRIVATE STUDENTS. Containing all the Exercises worked out, with brief Notes. By J. THORNTON. Oblong 4to. 10s. 6d.

**Wright.**—THE SCHOOL COOKERY-BOOK. Compiled and Edited by C. E. GUTHRIE WRIGHT, Hon Sec. to the Edinburgh School of Cookery. 18mo. 1s.

## ART AND KINDRED SUBJECTS.

**Anderson.**—LINEAR PERSPECTIVE, AND MODEL DRAWING. A School and Art Class Manual, with Questions and Exercises for Examination, and Examples of Examination Papers. By LAURENCE ANDERSON. With Illustrations. Royal 8vo. 2s.

**Collier.**—A PRIMER OF ART. With Illustrations. By JOHN COLLIER. 18mo. 1s.

**Cook.**—THE NATIONAL GALLERY: A POPULAR HANDBOOK TO. By EDWARD T. COOK, with a Preface by JOHN RUSKIN, LL.D., and Selections from his Writings. Second Edition. Crown 8vo. Half Morocco, 14s.

\* \* \* Also an Edition on large paper, limited to 250 copies. 2 vols. 8vo.

**Delamotte.**—A BEGINNER'S DRAWING BOOK. By P. H. DELAMOTTE, F.S.A. Progressively arranged. New Edition improved. Crown 8vo. 3s. 6d.

**Ellis.**—SKETCHING FROM NATURE. A Handbook for Students and Amateurs. By TRISTRAM J. ELLIS. With a Frontispiece and Ten Illustrations, by H. STACY MARKS, R.A., and Thirty Sketches by the Author. New Edition, revised and enlarged. Crown 8vo. 3s. 6d.

**Hunt.**—TALKS ABOUT ART. By WILLIAM HUNT. With a Letter from Sir J. E. MILLAIS, Bart., R.A. Crown 8vo. 3s. 6d.

**Meldola.**—THE CHEMISTRY OF PHOTOGRAPHY. By RAPHAEL MELDOLA, F.R.S., Professor of Chemistry in the Technical College, Finsbury, City and Guilds of London Institute for the Advancement of Technical Education. Crown 8vo. 6s. (*Nature Series.*)

**Taylor.**—A PRIMER OF PIANOFORTE PLAYING. By FRANKLIN TAYLOR. Edited by Sir GEORGE GROVE. 18mo. 1s.

## WORKS ON TEACHING.

**Arnold.**—REPORTS ON ELEMENTARY SCHOOLS. 1852-1882. By MATTHEW ARNOLD, D.C.L., LL.D. Edited by the Right Hon. Sir FRANCIS SANDFORD, K.C.B. Crown 8vo, 7s. 6d.

**Ball.**—THE STUDENT'S GUIDE TO THE BAR. By WALTER W. R. BALL, M.A., of the Inner Temple, Barrister-at-Law; Fellow and Assistant Tutor of Trinity College, Cambridge, and Fellow of University College, London. Fourth Edition Revised. Crown 8vo. 2s. 6d.

**Blakiston.**—THE TEACHER. Hints on School Management. A Handbook for Managers, Teachers' Assistants, and Pupil Teachers. By J. R. BLAKISTON, M.A. Crown 8vo. 2s. 6d. (Recommended by the London, Birmingham, and Leicester School Boards.)

"Into a comparatively small book he has crowded a great deal of exceedingly useful and sound advice. It is a plain, common-sense book, full of hints to the teacher on the management of his school and his children."—SCHOOL BOARD CHRONICLE.

**Calderwood.**—ON TEACHING. By Professor HENRY CALDERWOOD. New Edition. Extra fcap. 8vo. 2s. 6d.



**Carter.**—EYESIGHT IN SCHOOLS. A Paper read before the Association of Medical Officers of Schools on April 15th, 1885. By R. BRUDENELL CARTER, F.R.C.S., Ophthalmic Surgeon to St. George's Hospital. Crown 8vo. Sewed. 1s.

**Fearon.**—SCHOOL INSPECTION. By D. R. FEARON, M.A. Assistant Commissioner of Endowed Schools. New Edition. Crown 8vo. 2s. 6d.

**Geikie.**—THE TEACHING OF GEOGRAPHY. A Practical Handbook for the use of Teachers. By ARCHIBALD GEIKIE, F.R.S., Director-General of the Geological Survey of the United Kingdom, &c. (Being the Introductory Volume to Macmillan's Geographical Series.) Crown 8vo. 2s.

**Gladstone.**—OBJECT TEACHING. A Lecture delivered at the Pupil-Teacher Centre, William Street Board School, Hammersmith. By J. H. GLADSTONE, Ph.D., F.R.S., Member of the London School Board. With an Appendix. Crown 8vo. 3d.

"It is a short but interesting and instructive publication, and our younger teachers will do well to read it carefully and thoroughly. There is much in these few pages which they can learn and profit by."—THE SCHOOL-GUARDIAN.

**Hertel.**—OVERPRESSURE IN HIGH SCHOOLS IN DENMARK. By Dr. HERTEL, Municipal Medical Officer, Copenhagen. Translated from the Danish by C. GODFREY SØRENSEN. With Introduction by Sir J. CRICHTON-BROWNE, M.D., LL.D., F.R.S. Crown 8vo. 3s. 6d.

---

## DIVINITY.

\*\* For other Works by these Authors, see THEOLOGICAL CATALOGUE.

**Abbott (Rev. E. A.)**—BIBLE LESSONS. By the Rev. E. A. ABBOTT, D.D., formerly Head Master of the City of London School. New Edition. Crown 8vo. 4s. 6d.

"Wise, suggestive, and really profound initiation into religious thought."—GUARDIAN.

**Abbott—Rushbrooke.**—THE COMMON TRADITION OF THE SYNOPTIC GOSPELS, in the Text of the Revised Version. By EDWIN A. ABBOTT, D.D., formerly Fellow of St. John's College, Cambridge, and W. G. RUSHBROOKE, M.L., formerly Fellow of St. John's College, Cambridge. Cr. 8vo. 3s. 6d.

**The Acts of the Apostles.**—Being the Greek Text as revised by Professors WESTCOTT and HORT. With Explanatory Notes for the Use of Schools, by T. E. PAGE, M.A., late Fellow of St. John's College, Cambridge; Assistant Master at the Charterhouse. Fcap. 8vo. 4s. 6d.

- Arnold.**—Works by MATTHEW ARNOLD, D.C.L., formerly Professor of Poetry in the University of Oxford, and Fellow of Oriel.
- A BIBLE-READING FOR SCHOOLS.—THE GREAT PROPHECY OF ISRAEL'S RESTORATION** (Isaiah, Chapters xl.—lxvi.). Arranged and Edited for Young Learners. New Edition. 18mo, cloth. 1s.
- ISAIAH XL.—LXVI.** With the Shorter Prophecies allied to it. Arranged and Edited, with Notes. Crown 8vo. 5s.
- ISAIAH OF JERUSALEM, IN THE AUTHORISED ENGLISH VERSION.** With Introduction, Corrections, and Notes. Crown 8vo. 4s. 6d.
- Benham.**—A COMPANION TO THE LECTIONARY. Being a Commentary on the Proper Lessons for Sundays and Holy Days. By Rev. W. BENHAM, B.D., Rector of S. Edmund with S. Nicholas Acons, &c. New Edition. Crown 8vo. 4s. 6d.
- Cassel.**—MANUAL OF JEWISH HISTORY AND LITERATURE; preceded by a BRIEF SUMMARY OF BIBLE HISTORY. By DR. D. CASSEL. Translated by Mrs. HENRY LUCAS. Fcap. 8vo. 2s. 6d.
- Cheetham.**—A CHURCH HISTORY OF THE FIRST SIX CENTURIES. By the Ven. ARCHDEACON CHEETHAM, Crown 8vo. *[In the press.]*
- Cross.**—BIBLE READINGS SELECTED FROM THE PENTATEUCH AND THE BOOK OF JOSHUA. By the Rev. JOHN A. CROSS. Second Edition enlarged, with Notes. Globe 8vo. 2s. 6d.
- Curteis.**—MANUAL OF THE THIRTY-NINE ARTICLES. By G. H. CURTEIS, M.A., Principal of the Lichfield Theological College. *[In preparation.]*
- Davies.**—THE EPISTLES OF ST. PAUL TO THE EPHESIANS, THE COLOSSIANS, AND PHILEMON; with Introductions and Notes, and an Essay on the Traces of Foreign Elements in the Theology of these Epistles. By the Rev. J. LLEWELYN DAVIES, M.A., Rector of Christ Church, St. Marylebone; late Fellow of Trinity College, Cambridge. Second Edition. Demy 8vo. 7s. 6d.
- Drummond.**—THE STUDY OF THEOLOGY, INTRODUCTION TO. By JAMES DRUMMOND, LL.D., Professor of Theology in Manchester New College, London. Crown 8vo. 5s.
- Gaskoin.**—THE CHILDREN'S TREASURY OF BIBLE STORIES. By Mrs. HERMAN GASKOIN. Edited with Preface by Rev. G. F. MACLEAR, D.D. PART I.—OLD TESTAMENT HISTORY. 18mo. 1s. PART II.—NEW TESTAMENT. 18mo. 1s. PART III.—THE APOSTLES: ST. JAMES THE GREAT, ST. PAUL, AND ST. JOHN THE DIVINE. 18mo. 1s.

**Golden Treasury Psalter.**—Students' Edition. Being an Edition of "The Psalms Chronologically arranged, by Four Friends," with briefer Notes. 18mo. 3s. 6d.

**Greek Testament.**—Edited, with Introduction and Appendices, by CANON WESTCOTT and Dr. F. J. A. HORT. Two Vols. Crown 8vo. 10s. 6d. each.

Vol. I. The Text.

Vol. II. Introduction and Appendix.

**Greek Testament.**—Edited by Canon WESTCOTT and Dr. HORT. School Edition of Text. 12mo. cloth. 4s. 6d. 18mo. roan, red edges. 5s. 6d.

**GREEK TESTAMENT, SCHOOL READINGS IN THE.** Being the outline of the life of our Lord, as given by St. Mark, with additions from the Text of the other Evangelists. Arranged and Edited, with Notes and Vocabulary, by the Rev. A. CALVERT, M.A., late Fellow of St. John's College, Cambridge. Fcap. 8vo. 4s. 6d.

**THE ACTS OF THE APOSTLES.** Being the Greek Text as revised by Drs. WESTCOTT and HORT. With Explanatory Notes by T. E. PAGE, M.A., Assistant Master at the Charterhouse. Fcap. 8vo. 4s. 6d.

**THE GOSPEL ACCORDING TO ST. MATTHEW.** Being the Greek Text as revised by Drs. WESTCOTT and HORT. With Explanatory Notes by Rev. A. SLOMAN, M.A., Head Master of Birkenhead School. [*In preparation.*]

**THE GOSPEL ACCORDING TO ST. MARK.** Being the Greek Text as revised by Drs. WESTCOTT and HORT. With Explanatory Notes by Rev. J. O. F. MURRAY, M.A., Lecturer in Emmanuel College, Cambridge. Fcap. 8vo. [*In preparation.*]

**THE GOSPEL ACCORDING TO ST. LUKE.** Being the Greek Text as revised by Drs. WESTCOTT and HORT. With Explanatory Notes by Rev. JOHN BOND, M.A. [*In preparation.*]

**Hardwick.**—Works by Archdeacon HARDWICK:—

**A HISTORY OF THE CHRISTIAN CHURCH.** Middle Age. From Gregory the Great to the Excommunication of Luther. Edited by WILLIAM STUBBS, M.A., Regius Professor of Modern History in the University of Oxford. With Four Maps. New Edition. Crown 8vo. 10s. 6d.

**A HISTORY OF THE CHRISTIAN CHURCH DURING THE REFORMATION.** Ninth Edition. Edited by Professor STUBBS. Crown 8vo. 10s. 6d.

**Hoole.**—**THE CLASSICAL ELEMENT IN THE NEW TESTAMENT.** Considered as a Proof of its Genuineness, with an Appendix on the Oldest Authorities used in the Formation of the Canon. By CHARLES H. HOOLE, M.A., Student of Christ Church, Oxford. 8vo. 10s. 6d.

- Jennings and Lowe.**—THE PSALMS, WITH INTRODUCTIONS AND CRITICAL NOTES. By A. C. JENNINGS, M.A.; assisted in parts by W. H. LOWE, M.A. In 2 vols. Second Edition Revised. Crown 8vo. 10s. 6d. each.
- Kay.**—ST. PAUL'S TWO EPISTLES TO THE CORINTHIANS, A COMMENTARY ON. By the late Rev. W. KAY, D.D., Rector of Great Leghs, Essex, and Hon. Canon of St. Albans; formerly Principal of Bishop's College, Calcutta; and Fellow and Tutor of Lincoln College. Demy 8vo. 9s.
- Kuenen.**—PENTATEUCH AND BOOK OF JOSHUA: an Historico-Critical Inquiry into the Origin and Composition of the Hexateuch. By A. KUENEN, Professor of Theology at Leiden. Translated from the Dutch, with the assistance of the Author, by PHILLIP H. WICKSTEED, M.A. 8vo. 14s.  
The OXFORD MAGAZINE says:—"The work is absolutely indispensable to all special students of the Old Testament."
- Lightfoot.**—Works by the Right Rev. J. B. LIGHTFOOT, D.D., D.C.L., LL.D., Lord Bishop of Durham.
- ST. PAUL'S EPISTLE TO THE GALATIANS. A Revised Text, with Introduction, Notes, and Dissertations. Ninth Edition, revised. 8vo. 12s.
- ST. PAUL'S EPISTLE TO THE PHILIPPIANS. A Revised Text, with Introduction, Notes, and Dissertations. Ninth Edition, revised. 8vo. 12s.
- ST. CLEMENT OF ROME—THE TWO EPISTLES TO THE CORINTHIANS. A Revised Text, with Introduction and Notes. 8vo. 8s. 6d.
- ST. PAUL'S EPISTLES TO THE COLOSSIANS AND TO PHILEMON. A Revised Text, with Introductions, Notes, and Dissertations. Eighth Edition, revised. 8vo. 12s.
- THE APOSTOLIC FATHERS. Part II. S. IGNATIUS—S. POLYCARP. Revised Texts, with Introductions, Notes, Dissertations, and Translations. 2 volumes in 3. Demy 8vo. 48s.
- APOSTOLIC FATHERS. Abridged Edition. With short Introductions, Greek Text, and English Translation. By the same Author. 8vo. *[In the press.]*
- ESSAYS ON THE WORK ENTITLED "SUPERNATURAL RELIGION." (Reprinted from the *Contemporary Review*.) 8vo. 10s. 6d.
- Maclear.**—Works by the Rev. G. F. MACLEAR, D.D., Canon of Canterbury, Warden of St. Augustine's College, Canterbury, and late Head-Master of King's College School, London:—
- A CLASS-BOOK OF OLD TESTAMENT HISTORY. New Edition, with Four Maps. 18mo. 4s. 6d.
- A CLASS-BOOK OF NEW TESTAMENT HISTORY, including the Connection of the Old and New Testaments. With Four Maps. New Edition. 18mo. 5s. 6d.

**Maclear—continued.**

A SHILLING BOOK OF OLD TESTAMENT HISTORY, for National and Elementary Schools. With Map. 18mo, cloth. New Edition.

A SHILLING BOOK OF NEW TESTAMENT HISTORY, for National and Elementary Schools. With Map. 18mo, cloth. New Edition.

These works have been carefully abridged from the Author's large manuals.

CLASS-BOOK OF THE CATECHISM OF THE CHURCH OF ENGLAND. New Edition. 18mo. 1s. 6d.

A FIRST CLASS-BOOK OF THE CATECHISM OF THE CHURCH OF ENGLAND. With Scripture Proofs, for Junior Classes and Schools. New Edition. 18mo. 6d.

A MANUAL OF INSTRUCTION FOR CONFIRMATION AND FIRST COMMUNION. WITH PRAYERS AND DEVOTIONS. 32mo, cloth extra, red edges. 2s.

AN INTRODUCTION TO THE CREEDS. 18mo. 2s. 6d.

CLASS BOOK OF THE THIRTY-NINE ARTICLES.

[In the press.

**Maurice.**—THE LORD'S PRAYER, THE CREED, AND THE COMMANDMENTS. A Manual for Parents and Schoolmasters: To which is added the Order of the Scriptures. By the Rev. F. DENISON MAURICE, M.A. 18mo, cloth, limp. 1s.

**Pentateuch and Book of Joshua:** an Historico-Critical Inquiry into the Origin and Composition of the Hexateuch. By A. KUENEN, Professor of Theology at Leiden. Translated from the Dutch, with the assistance of the Author, by PHILIP H. WICKSTEED, M.A. 8vo. 14s.

**Procter.**—A HISTORY OF THE BOOK OF COMMON PRAYER, with a Rationale of its Offices. By Rev. F. PROCTER. M.A. 18th Edition, revised and enlarged. Crown 8vo. 10s. 6d.

**Procter and Maclear.**—AN ELEMENTARY INTRODUCTION TO THE BOOK OF COMMON PRAYER. Re-arranged and supplemented by an Explanation of the Morning and Evening Prayer and the Litany. By the Rev. F. PROCTER and the Rev. Dr. MACLEAR. New and Enlarged Edition, containing the Communion Service and the Confirmation and Baptismal Offices. 18mo. 2s. 6d.

**Psalms. The, with Introductions and Critical Notes.**—By A. C. JENNINGS, M.A., Jesus College, Cambridge, Tyrwhitt Scholar, Crosse Scholar, Hebrew University Prizeman, and Fry Scholar of St. John's College, Carus and Scholefield Prizeman, Vicar of Whittlesford, Cambs.; assisted in Parts by W. H. LOWE, M.A., Hebrew Lecturer and late Scholar of Christ's College, Cambridge, and Tyrwhitt Scholar. In 2 vols. Second Edition Revised. Crown 8vo. 10s 6d. each.

- Ramsay.**—THE CATECHISER'S MANUAL; or, the Church Catechism Illustrated and Explained, for the Use of Clergymen, Schoolmasters, and Teachers. By the Rev. ARTHUR RAMSAY, M.A. New Edition. 18mo. 1s. 6d.
- Rendall.**—THE EPISTLE TO THE HEBREWS. English Text with Commentary. By the Rev. F. RENDALL, M.A., formerly Fellow of Trinity College, Cambridge, and Master of Harrow School. Crown 8vo. 7s. 6d.
- Ryle.**—AN INTRODUCTION TO THE CANON OF THE OLD TESTAMENT. By Rev. H. E. RYLE, M.A., Fellow of King's College, and Hulsean Professor of Divinity in the University of Cambridge. Crown 8vo. [*In preparation.*]
- Simpson.**—AN EPITOME OF THE HISTORY OF THE CHRISTIAN CHURCH DURING THE FIRST THREE CENTURIES, AND OF THE REFORMATION IN ENGLAND. Compiled for the use of Students in Schools and Universities by the Rev. WILLIAM SIMPSON, M.A., Queen's College, Cambridge. Seventh Edition. Fcap. 8vo. 3s. 6d.
- St. James' Epistle.**—The Greek Text with Introduction and Notes. By Rev. JOSEPH MAYOR, M.A., Professor of Moral Philosophy in King's College, London. 8vo. [*In preparation.*]
- St. John's Epistles.**—The Greek Text with Notes and Essays, by BROOKE FOSS WESTCOTT, D.D., Regius Professor of Divinity, and Fellow of King's College, Cambridge, Canon of Westminster &c. Second Edition Revised. 8vo. 12s. 6d.
- St. Paul's Epistles.**—Greek Text, with Introduction and Notes.
- THE EPISTLE TO THE GALATIANS. Edited by the Right Rev. J. B. LIGHTFOOT, D.D., Bishop of Durham. Ninth Edition. 8vo. 12s.
- THE EPISTLE TO THE PHILIPPIANS. By the same Editor. Ninth Edition. 8vo. 12s.
- THE EPISTLE TO THE COLOSSIANS AND TO PHILEMON. By the same Editor. Eighth Edition. 8vo. 12s.
- THE EPISTLE TO THE ROMANS. Edited by the Very Rev. C. J. VAUGHAN, D.D., Dean of Llandaff, and Master of the Temple. Fifth Edition. Crown 8vo. 7s. 6d.
- THE EPISTLE TO THE PHILIPPIANS, with Translation, Paraphrase, and Notes for English Readers. By the same Editor. Crown 8vo. 5s.
- THE EPISTLE TO THE THESSALONIANS, COMMENTARY ON THE GREEK TEXT. By JOHN EADIE, D.D., LL.D. Edited by the Rev. W. YOUNG, M.A., with Preface by Professor CAIRNS. 8vo. 12s.

**St. Paul's Epistles**—*continued.*

THE EPISTLES TO THE EPHESIANS, THE COLOSSIANS, AND PHILEMON; with Introductions and Notes, and an Essay on the Traces of Foreign Elements in the Theology of these Epistles. By the Rev. J. LLEWELYN DAVIES, M.A., Rector of Christ Church, St. Marylebone; late Fellow of Trinity College, Cambridge. Second Edition, revised. Demy 8vo. 7s. 6d.

THE TWO EPISTLES TO THE CORINTHIANS, A COMMENTARY ON. By the late Rev. W. KAY, D.D., Rector of Great Leghs, Essex, and Hon. Canon of St. Albans; formerly Principal of Bishop's College, Calcutta; and Fellow and Tutor of Lincoln College. Demy 8vo. 9s.

**The Epistle to the Hebrews.** In Greek and English. With Critical and Explanatory Notes. Edited by Rev. FREDERIC RENDALL, M.A., formerly Fellow of Trinity College, Cambridge, and Assistant-Master at Harrow School. Crown 8vo. 6s.

THE ENGLISH TEXT, WITH COMMENTARY. By the same Editor. Crown 8vo. 7s. 6d.

**The Epistle to the Hebrews.** The Greek Text with Notes and Essays by B. F. WESTCOTT, D.D. 8vo. [*In the press.*]

**Westcott.**—Works by BROOKE FOSS WESTCOTT, D.D., Canon of Westminster, Regius Professor of Divinity, and Fellow of King's College, Cambridge.

A GENERAL SURVEY OF THE HISTORY OF THE CANON OF THE NEW TESTAMENT DURING THE FIRST FOUR CENTURIES. Sixth Edition. With Preface on "Supernatural Religion." Crown 8vo. 10s. 6d.

INTRODUCTION TO THE STUDY OF THE FOUR GOSPELS. Seventh Edition. Crown 8vo. 10s. 6d.

THE BIBLE IN THE CHURCH. A Popular Account of the Collection and Reception of the Holy Scriptures in the Christian Churches. New Edition. 18mo, cloth. 4s. 6d.

THE EPISTLES OF ST. JOHN. The Greek Text, with Notes and Essays. Second Edition Revised. 8vo. 12s. 6d.

THE EPISTLE TO THE HEBREWS. The Greek Text Revised, with Notes and Essays. 8vo. [*In the press.*]

SOME THOUGHTS FROM THE ORDINAL. Cr. 8vo. 1s. 6d.

**Westcott and Hort.**—THE NEW TESTAMENT IN THE ORIGINAL GREEK. The Text Revised by B. F. WESTCOTT, D.D., Regius Professor of Divinity, Canon of Westminster, and F. J. A. HORT, D.D., Lady Margaret Professor of Divinity, Fellow of Emmanuel College, Cambridge; late Fellows of Trinity College, Cambridge. 2 vols. Crown 8vo. 10s. 6d. each.

Vol. I. Text.

Vol. II. Introduction and Appendix.

**Westcott and Hort.**—THE NEW TESTAMENT IN THE ORIGINAL GREEK, FOR SCHOOLS. The Text Revised by BROOKE FOSS WESTCOTT, D.D., and FENTON JOHN ANTHONY HORT, D.D. 12mo. cloth. 4s. 6d. 18mo. roan, red edges. 5s. 6d.

**Wilson.**—THE BIBLE STUDENT'S GUIDE to the more Correct Understanding of the English Translation of the Old Testament, by reference to the original Hebrew. By WILLIAM WILSON, D.D., Canon of Winchester, late Fellow of Queen's College, Oxford. Second Edition, carefully revised. 4to. cloth. 25s.

**Wright.**—THE BIBLE WORD-BOOK: A Glossary of Archaic Words and Phrases in the Authorised Version of the Bible and the Book of Common Prayer. By W. ALDIS WRIGHT, M.A., Vice-Master of Trinity College, Cambridge. Second Edition, Revised and Enlarged. Crown 8vo. 7s. 6d.

**Yonge (Charlotte M.).**—SCRIPTURE READINGS FOR SCHOOLS AND FAMILIES. By CHARLOTTE M. YONGE. Author of "The Heir of Redclyffe." In Five Vols.

FIRST SERIES. GENESIS TO DEUTERONOMY. Extra fcap. 8vo. 1s. 6d. With Comments, 3s. 6d.

SECOND SERIES. From JOSHUA to SOLOMON. Extra fcap. 8vo. 1s. 6d. With Comments, 3s. 6d.

THIRD SERIES. The KINGS and the PROPHETS. Extra fcap. 8vo. 1s. 6d. With Comments, 3s. 6d.

FOURTH SERIES. The GOSPEL TIMES. 1s. 6d. With Comments. Extra fcap. 8vo, 3s. 6d.

FIFTH SERIES. APOSTOLIC TIMES. Extra fcap. 8vo. 1s. 6d. With Comments, 3s. 6d.

**Zechariah—Lowe.**—THE HEBREW STUDENT'S COMMENTARY ON ZECHARIAH; HEBREW AND LXX. With Excursus on Syllable-dividing, Metheg, Initial Dagesh, and Siman Rappheh. By W. H. LOWE, M.A., Hebrew Lecturer at Christ's College, Cambridge. Demy 8vo. 10s. 6d.









