



CORNELL  
UNIVERSITY  
LIBRARY



FINE ARTS LIBRARY

CORNELL UNIVERSITY LIBRARY



3 1924 081 380 937



## Cornell University Library

The original of this book is in  
the Cornell University Library.

There are no known copyright restrictions in  
the United States on the use of the text.











*International Library of Technology*

31F

# Brick, Stone, and Plaster

346 ILLUSTRATIONS, 11 IN COLORS

Prepared Under Supervision of

WILLIAM B. LOWNDES, Ph. B.

DIRECTOR, SCHOOL OF ARCHITECTURE  
INTERNATIONAL CORRESPONDENCE  
SCHOOLS

COMMON BRICKWORK  
FACE AND ORNAMENTAL BRICKWORK  
ARCHITECTURAL TERRA COTTA  
HOLLOW TILE  
BUILDING STONE  
PLASTERING

Published by  
INTERNATIONAL TEXTBOOK COMPANY  
SCRANTON, PA.

1925

Common Brickwork: Copyright, 1920, by INTERNATIONAL TEXTBOOK COMPANY.  
Face and Ornamental Brickwork: Copyright, 1919, by INTERNATIONAL TEXTBOOK COMPANY.  
Architectural Terra Cotta: Copyright, 1920, by INTERNATIONAL TEXTBOOK COMPANY.  
Hollow Tile: Copyright, 1919, by INTERNATIONAL TEXTBOOK COMPANY.  
Building Stone: Copyright, 1898, by THE COLLIERY ENGINEER COMPANY. Copyright, 1907, 1921, by INTERNATIONAL TEXTBOOK COMPANY.  
Plastering: Copyright, 1923, by INTERNATIONAL TEXTBOOK COMPANY.

---

Copyright in Great Britain

---

All rights reserved

---

Printed in U. S. A.

PRESS OF  
INTERNATIONAL TEXTBOOK COMPANY  
SCRANTON, PA.

## PREFACE

---

The volumes of the International Library of Technology are made up of Instruction Papers, or Sections, comprising the various courses of instruction for students of the International Correspondence Schools. The original manuscripts are prepared by persons thoroughly qualified both technically and by experience to write with authority, and in many cases they are regularly employed elsewhere in practical work as experts. The manuscripts are then carefully edited to make them suitable for correspondence instruction. The Instruction Papers are written clearly and in the simplest language possible, so as to make them readily understood by all students. Necessary technical expressions are clearly explained when introduced.

The great majority of our students wish to prepare themselves for advancement in their vocations or to qualify for more congenial occupations. Usually they are employed and able to devote only a few hours a day to study. Therefore every effort must be made to give them practical and accurate information in clear and concise form and to make this information include all of the essentials but none of the non-essentials. To make the text clear, illustrations are used freely. These illustrations are especially made by our own Illustrating Department in order to adapt them fully to the requirements of the text.

In the table of contents that immediately follows are given the titles of the Sections included in this volume, and under each title are listed the main topics discussed.

INTERNATIONAL TEXTBOOK COMPANY





## CONTENTS

---

**NOTE.**—This volume is made up of a number of separate Sections, the page numbers of which usually begin with 1. To enable the reader to distinguish between the different Sections, each one is designated by a number preceded by a Section mark (§), which appears at the top of each page, opposite the page number. In this list of contents, the Section number is given following the title of the Section, and under each title appears a full synopsis of the subjects treated. This table of contents will enable the reader to find readily any topic covered.

COMMON BRICKWORK, § 7		<i>Pages</i>
Brick .....		1- 7
Manufacture of Brick .....		2- 3
Hand-made bricks; Machine-made bricks; Drying and burning of brick.		
Classification of Brick .....		4- 6
Size, Weight, and Quality of Bricks.....		7
Brickwork .....		8-70
General Discussions .....		8-11
Strength of brickwork; Measurement of brickwork.		
Bricklaying .....		12-24
Tools and methods; Scaffolding.		
Brick Walls .....		25-32
Types of brick walls; Thickness of walls.		
Bond in Brickwork .....		33-44
Standard forms; Bonding face brick; Bonding hollow walls; Bonding walls at right angles; Joining new walls to old walls.		
Openings in Walls .....		45-52
Brick arches in general; Chases and flues.		
Backing Up .....		53-54
Efflorescence.		
Hangers, Anchors, etc. ....		55-59
Chimneys and Fireplaces .....		60-70

## FACE AND ORNAMENTAL BRICKWORK, § 11

	<i>Pages</i>
Introduction .....	1-14
Definitions .....	4- 5
Brief History of Brickwork.....	6-14
Face Brickwork .....	15-62
Description of Face Brickwork.....	15-26
Brick shapes and sizes; Brick textures; Brick colors; Molded brick.	
Mortar and Mortar Joints.....	27-35
Bond .....	36-39
Pattern Work .....	40-59
Ornamental Brickwork .....	60-62

## ARCHITECTURAL TERRA COTTA, § 12

Advantages, Uses, and Designs.....	1-78
Introduction .....	1
Advantages and Uses of Terra Cotta.....	2- 4
Design of Terra Cotta.....	5-20
Characteristics affecting design; Plain surfaces; Model- ing terra cotta; Coloring terra cotta; Designing to resemble other materials; Stock design; Strength and weight of terra cotta.	
Architect's Drawings .....	21-23
Manufacturer's Drawings .....	24-27
Modeling .....	28-29
Molds .....	30
Manufacture of Terra Cotta.....	30-38
Materials; Finishes and colors; Fitting and numbering the blocks.	
Details of Construction .....	39-66
Shipping and Handling Terra Cotta.....	67
Setting the Terra Cotta.....	68-78

## HOLLOW TILE, § 13

Advantages and Nature of Hollow Tile.....	1- 4
Shapes and Kinds of Hollow Tile.....	5-29
Regular, or Box-Shaped, Tile .....	5-14
T-Shaped Tile .....	15-19

HOLLOW TILE—(Continued)		<i>Pages</i>
H-Shaped Tile .....		20-22
Special Tile .....		23-27
Surfaces of Tile .....		28
Strength of Tile .....		29
Uses of Hollow Terra-Cotta Tile.....		30-61
Foundations of Hollow Tile.....		31-32
Exterior Walls of Hollow Tile.....		33-52
Walls of regular, or box-shaped, tile; Walls of H tile; Walls of T-shaped tile; Veneered walls; Openings in walls.		
Attaching Furring, Trim, Etc., to Walls.....		63-55
Partitions of Hollow Tile.....		56
Floor Systems .....		57-60
Roof Construction .....		61
Stucco Finish .....		62-66
Composition of Stucco .....		62-63
Application of Stucco .....		64
Finishes .....		65-66
Examples of Buildings of Hollow Tile.....		67-82

BUILDING STONE, § 37

Varieties and Qualities of Stone.....		1-17
Introduction .....		1
Unstratified, or Igneous, Rock.....		2- 4
Stratified, or Sedimentary, Rock.....		5- 8
Limestones; Marble; Serpentine; Sandstones; Bluestone; Slate.		
Qualities of Good Stone.....		9-15
Strength and weight; Color; Durability; Seasoning of stone.		
Inspection and Tests.....		16-17
Stone Cutting and Finishing.....		18-20
Cutting Stone by Machine.....		21-33
Saws; Planers; Lathes; Polishers; Pneumatic tools.		
Cutting Stone by Hand.....		34-36
Finishing of Stonework .....		37-44
Carved Work .....		45-55

PLASTERING, § 38		<i>Pages</i>
Preparation of the Base.....		1-12
Surfaces to be Plastered.....		1
Furring .....		2- 5
Grounds .....		6- 8
Corner Beads .....		9-12
Lath .....		13-31
Wooden Lath .....		13-16
Metal Lath .....		17-28
Plaster Boards and Wall Boards.....		29-31
Interior Plastering .....		32-51
Preparation for plastering; Plasterers' tools; Lime plaster; Gypsum plaster; Application of lime plaster; Application of gypsum plasters; Keene's cement; Portland cement plaster; Caen stone plaster.		
Ornamental Plastering .....		52-62
Materials and preparation; Application of the plaster.		
Exterior Plastering .....		63-90
Stucco .....		63-86
Kinds and advantages; Preparatory work for stucco; Materials for stucco mortar; Proportions of materials; Mixing; Applying the stucco; Stucco finishes; Color effects; Waterproofing of stucco; Magnesite stucco.		
Miscellaneous .....		87-90
Whitewashing; Overcoating.		

# COMMON BRICKWORK

---

## BRICK

**1. Definition and Description.**—Bricks may be defined as solid building units made of burned clay. They are comparatively small in size, therefore easily handled, and being already burned are extensively used in buildings that are intended to be fire-resistive and in other forms of construction that are permanent in character. When referred to in the mass, or as a building material, they are called *brick*.

Brick can be made cheaply and, when hard burned and laid in good mortar, is one of the most durable building materials in use. Common brick can be used to form solid, or even hollow, walls when desired, or can be used to back up a wall that is faced with a most costly material, such as face brick, terra cotta or stone. While common bricks are manufactured mainly with a view to service, they may be used for facing walls. In many localities the clays or shales used in making common brick produce, when burned, a variety of colors and textures resulting in the most pleasing effects as laid in the wall. These effects may be obtained by using the bricks as they come from the kiln without selecting, or by selecting and grading the bricks. The possibilities of artistic treatment of wall surfaces are not even limited by the range of color or texture. With the use of any good hard brick a variation in color effect and texture of wall surface may be obtained by varying the character of the bond and the size and color of the mortar joint. This use of certain kinds of common brick is also discussed and illustrated in the Section on *Face and Ornamental Brickwork*.

## MANUFACTURE OF BRICK

**2. Ingredients.**—The principal material used in making brick is clay, where naturally suitable as it comes from the clay bank, or a combination of clay and sand, called silicate of alumina. Suitable basic materials of this nature are found throughout almost every state in this country. Brickyards abound in nearly every locality and in the making of brick and other clay products a practically inexhaustible material is drawn upon. This material, as found in nature, generally contains small quantities of other chemical substances such as iron, magnesia, lime, potash, etc. Each of these substances has a particular effect upon the color, hardness, and durability of the brick, and by the judicious use of these substances, either alone or in combination, certain characteristics in the finished brick can be obtained. Such combinations are often made by mixing together two or more clays containing different chemical substances.

---

### HAND-MADE BRICKS

**3.** In the process of making clay bricks by hand, the clay is mixed with water and worked to a plastic state in a *pug mill*, and then the soft plastic clay is pressed into molds by hand. The molds are sometimes dipped into water, just before being filled with the clay, to prevent the mud from sticking to them when the mold is removed. Bricks molded in these wet forms are known as *slop bricks* and also as *water-struck bricks*. Sand is sometimes sprinkled into the molds to prevent the clay sticking, or to produce a sand-finished texture on the faces as laid, and the bricks from sanded molds are called *sanded bricks*. After the bricks are shaped in the mold, they are removed and laid in the sun, or in a drying house, for 3 or 4 days, after which they are stacked in kilns and burned.

The hand method of making bricks and the sun method of drying, being very slow and laborious, have been almost entirely displaced by more economical and expeditious ones in which the work is done by machinery.



**MACHINE-MADE BRICKS**

4. Nearly all bricks are now made by machinery. Where they are made on a large scale, steam shovels frequently are used for excavating the clay, and conveyors carry the raw clay to the mill and also convey the molded bricks to the drying sheds and the kilns.

Machine-made bricks are usually formed by one of three methods known as the soft-mud, the stiff-mud, and the dry-clay process.

5. **Soft-Mud Process.**—In the **soft-mud process**, the clay is soaked in water until soft. It is then thoroughly mixed by machinery, and pressed into molds by a plunger. The bricks are then dried and burned.

6. **Stiff-Mud Process.**—In the **stiff-mud process**, the clay is first thoroughly ground, and just enough water is added to make a stiff mud. After this mud is mixed in a pug mill, it is placed in a machine having a die the exact size of the brick required. The opening in this die is made the size of either the end or the side of a brick. The machine forces a continuous bar of clay through this die, and as it emerges it is automatically cut into bricks, which are then taken to the drying yard. The bricks that are cut on the ends are called *end cut*. Those cut on the sides are known as *side cut*. The soft bricks are placed in rows in a yard covered by a rough shed, with open sides, where they are sun or air dried for a considerable length of time or are run on special trucks into drying houses and are dried in from 4 to 8 days by steam or waste heat from the kilns. When properly dried they are placed in the kiln and burned.

7. **Dry-Clay Process.**—The process often employed in the best work is the **dry-clay process**. In this method of manufacturing brick, the clay is used just as it comes from the bank, and is apparently perfectly dry. It contains, however, about from 7 to 10 per cent. of moisture. The clay is filled loosely into molds of the same width and length as a brick, but deeper than the required thickness of the brick. A plunger

that exactly fits the mold is then forced in under heavy pressure and compresses the clay to the size of the brick desired. The bricks are then removed to the kiln and fired.

*Molded bricks* are made in the same way, the difference being that the mold is made to give the shape of the brick required.

Whenever the term *pressed brick* is used, it should mean brick made by the dry process. There are many so-called *dressed* or *face bricks*, however, that are made by recompressing soft-mud bricks.

---

#### DRYING AND BURNING OF BRICK

8. Bricks must be dried before being burned. Soft-mud bricks naturally require a longer time to dry than stiff-mud bricks. Having been properly dried, they are placed in kilns and burned. The types of kilns used are the up-draft, the down-draft, and the continuous kilns. The details of these kilns and their operation will not be described here. The important thing is that the bricks shall be well burned and satisfactory in shape and color. It might be said, however, that bricks burned in the modern forms of kilns are more uniform in color, shape, and hardness than those made in the old-fashioned kiln.

---

#### CLASSIFICATION OF BRICK

9. **Common Brick.**—The term *common brick* includes all brick made for structural purposes and produced without artificial scoring or marking of the exposed surface to give especial texture.

The distinguishing line between common and face brick in modern practice seems to be the special mixing of ingredients and the artificial coloring and scoring or rough texture, or the repressing process of the smooth brick, and the fact that face brick are graded, handled, and packed with great care.

Many face-brick plants and nearly all paving plants produce a proportion of common brick. Face brick *culls* are sold as *commons*.

The terms applied to grades of common brick vary in different parts of the country. In some places the bricks, although not alike, are sold without selection or grading. In other places the kiln is graded as *front* brick and *back* brick, the front being hardest burned. In others there are *hard* and *kiln run* brick.

In the overburned brick called *clinkers*, the clay fuses and causes irregular shapes and sizes. These bricks are usually extremely hard and very durable. Clinker bricks are in favor with many architects for ornamental purposes and should be laid with proper bond, size and kind of joint and color of the mortar.\*

Common bricks burned in the old-style up-draft kilns are classified according to their position in the kiln, which affects the amount of heat to which they are subjected. In some localities three grades of brick are produced in these kilns, namely, *arch* or *clinker* brick; *red*, or *well-burned*, brick; and *soft*, or *salmon*, brick. In other localities four grades are produced, namely: *rough-hard* (corresponding to arch brick), *straight-hard*, *stretcher*, and *salmon*.

**Arch, or clinker, brick** is the name applied to the bricks that have been nearest the fire and are consequently overburned.

**Red, well-burned, or straight-hard, brick** constitutes the hardest and the largest part of the product of the kiln; *stretcher* brick being a selection of the most uniform of these.

**Salmon brick** is the name applied to those that have been farthest from the fire and are consequently underburned and soft. In many localities these are used for interior, or unexposed walls, party walls and others not carrying heavy loads.

In certain localities the clay is of such a composition that the best brick from the kiln is of a salmon color and such brick should not be confused with the salmon brick just described.

The American Society for Testing Materials has adopted names for common brick as follows: *vitrified brick*, *hard brick*, *medium brick*, and *soft brick*. These grades conform in general to the classification just mentioned.

**10. Face Brick.**—Face bricks are made of specially selected materials so that the brick shall be of certain desired

colors, and with the faces scored or of a rough texture. These bricks are described in the Section *Face and Ornamental Brickwork*. Common bricks are often made or selected for color, *fire-flashed* effects and shape, and used for facing brick walls.

**11. Pressed Brick.**—Pressed bricks are those that have been pressed in a machine, and are usually hard, smooth, and have sharp corners and true shapes. They are used as face brick.

**12. Firebrick.**—Firebricks are made from fireclay and are used for lining furnaces, lime kilns, fireplaces, and chimneys in factories. They are usually somewhat larger than ordinary building bricks, and should be of homogeneous composition and texture, uniform in size, of a regular shape, easily cut, and not fusible. The best firebricks are hand-molded.

**13. Paving Brick.**—Paving bricks are usually made by the stiff-mud process, being repressed to give them a better shape, and are composed of about three parts of shale clay to one part of fireclay. They are burned at a high temperature to the point of vitrification, that is, to a heat at which they begin to fuse or melt. These bricks have a high crushing strength and absorb very little moisture. They are used principally for paving driveways, and occasionally for paving flat roofs on fireproof buildings.

**14. Hollow Brick.**—Hollow bricks are made of a stiff-mud mixture by machinery, as holes must be formed in the body of the brick. Hollow bricks are now being made more generally by manufacturers of terra-cotta tile, as the material and machinery used in manufacturing tile is better adapted to making hollow brick than is the machinery used in brick making.

**15. Sand, or Sand-Lime, Brick.**—The composition of sand brick is usually 95 per cent. of sand and 5 per cent. of slaked lime. This mixture is forced into molds under a very high pressure, and the bricks are removed from the molds and heated with superheated steam. These bricks can be made in

many colors by artificial means, and can thus be used to effect the most pronounced designs. Sand bricks are manufactured by many firms in the United States, some of which make a very good dense brick, while others make an inferior sandy article.

---

### SIZE, WEIGHT, AND QUALITY OF BRICKS

**16. Size and Weight.**—There is no universally accepted standard size of brick in America, although the American Society for Testing Materials and the Common Brick Manufacturers Association of America have adopted as a standard size for common brick, 8 in.  $\times$  3 $\frac{3}{4}$  in.  $\times$  2 $\frac{1}{4}$  in. The dimensions of brick vary with the locality and also with the maker. Bricks taken from the same kiln will vary in size due to the amount of heat to which they have been subjected.

In the New England States, the average size of a common brick is about 7 $\frac{3}{4}$  in.  $\times$  3 $\frac{3}{4}$  in.  $\times$  2 $\frac{1}{4}$  in.; New York and New Jersey bricks will run about 8 in.  $\times$  4 in.  $\times$  2 $\frac{1}{2}$  in.; and the walls laid in them will measure about 8, 12, 16, and 20 inches in thickness for 1, 1 $\frac{1}{2}$ , 2, and 2 $\frac{1}{2}$  bricks. Some of the western common bricks measure 8 $\frac{1}{2}$  in.  $\times$  4 $\frac{1}{8}$  in.  $\times$  2 $\frac{1}{2}$  in., and the thickness of the walls measures about 9, 13, 18, and 22 inches for thicknesses of 1, 1 $\frac{1}{2}$ , 2, and 2 $\frac{1}{2}$  bricks. On the seacoast of some of the Southern States, the bricks will average 9 in.  $\times$  4 $\frac{1}{2}$  in.  $\times$  3 in.

The weight of bricks varies considerably with the material used in their manufacture and also with their size. Common bricks will average about 4 $\frac{1}{2}$  pounds each.

**17. Quality.**—All bricks should be of uniform dimensions, free from twists, cracks, and pebbles, and should have sharp corners. The bricks should be well burned but not vitrified lest they become brittle. When two bricks are struck together, they should emit a metallic ring. A good brick will not absorb over 10 per cent. of its weight of water if allowed to soak for 24 hours.

### COLOR OF BRICK

**18.** The color of brick is usually not considered of any importance in common brickwork, but as walls of this kind of brick are sometimes exposed to view, the selection of bricks as to color and shade may be desired and consequently the architect's specifications should clearly state if this selection is required.

The color of common bricks depends largely upon the kind of clay used in making them and the temperature attained in the kiln during the burning.

Bricks burned in down-draft kilns are more uniformly burned and are consequently of a more uniform red color.

---

## BRICKWORK

---

### GENERAL DISCUSSION

**19. Definition.**—By the term *brickwork* is meant any construction made of bricks laid up in mortar. It can readily be seen that the strength of brickwork is not dependent on the strength of the brick alone. Other factors influence this, such as the strength of the mortar and the method of laying up and bonding the brick. Therefore, the value of brickwork, so far as strength and stability is concerned, may be decreased by the use of inferior mortar or by being laid by a bricklayer who does not understand his trade.

**20. Importance of Mortar.**—In laying bricks, it is customary to bed them in mortar. The mortar serves several purposes. It tends to make the wall waterproof and air-proof under ordinary conditions; it forms a cushion to take up the irregularities in the bricks and thus distributes the pressure evenly, and it bonds the whole wall into one solid mass, which increases its strength and stability.

Mortar for brickwork may be made of various combinations. It may be formed either of slaked or hydrated lime and sand in

proper proportions, or of lime and sand mixed with a small quantity of cement. It may also be made of cement and sand, or cement and sand to which a small percentage of slaked or hydrated lime is added. Lime mortar is, however, to be avoided in work coming in contact with earth or subject to dampness. Mortars of various kinds and qualities are more fully discussed in the Section *Limes, Cements, and Mortars*.

**21. Size of Mortar Joints.**—With soft-mud or stiff-mud bricks there are likely to be some irregularities which make necessary larger mortar joints than are generally required for pressed brick. For this reason common bricks are generally laid in mortar about  $\frac{1}{4}$  inch to  $\frac{1}{2}$  inch in thickness.

If a wall is faced with common bricks or bricks that have a rough texture, the joints in the facing are sometimes made as much as  $\frac{3}{4}$  inch in thickness and the backing is adjusted either by additional courses of bricks or thicker mortar joints than usual to bring the two kinds of brickwork to the same level, so that they can be bonded together at approximately every six or eight courses in the height of the wall.

---

#### STRENGTH OF BRICKWORK

**22.** Bricks for ordinary requirements are seldom tested for crushing strength, as the masonry formed of well-burned brick laid in good cement mortar will carry all ordinary loads. Bricks should not fail, however, under a crushing load of less than 1,800 pounds per square inch.

The strength of brickwork is influenced by the quality of the brick and the mortar of which it is composed. In cases where the brick is harder than the mortar, the latter is the factor that determines the strength of the brickwork. For this reason the load that may be placed upon brickwork varies with the kind of mortar that is used in its construction. These allowable loads are stated in the building laws in various localities. Local building laws should therefore be consulted when determining the loads on walls of buildings that come under the jurisdiction of such laws. Where no such laws exist, the Building Code



recommended by the National Board of Fire Underwriters is authority for the statement that 111 pounds per square inch may be taken as a safe load for masonry formed of bricks laid in good lime mortar; 208 pounds per square inch for lime and Portland cement mortar; 208 pounds for natural cement mortar and 250 pounds for Portland cement mortar in the proportion of three parts of sand to one part of cement, of which not more than 15 per cent. of the Portland cement by volume may be replaced by an equal amount of dry hydrated lime.

#### MEASUREMENT OF BRICKWORK

**23.** The usual method of measuring brickwork is by the thousand bricks laid in the wall. A customary method of estimating the number of bricks in a piece of brickwork is first to determine the entire area of the face of the wall in square feet, measurements being taken on the outside of the wall, and not on the inside. This is done to offset the extra labor that is required in laying up the corners or angles. The number of bricks is computed approximately from these areas, using the number of bricks to the square foot as shown in Table I. Thus, when using a brick  $8'' \times 3\frac{3}{4}'' \times 2\frac{1}{4}''$ , laid with a  $\frac{1}{2}$ -inch joint, there would be 6.17, or  $6\frac{1}{8}$ , bricks per square foot for a wall 4 or  $4\frac{1}{2}$  inches, or 1 brick, thick;  $12\frac{1}{3}$  bricks for a wall 8 or 9 inches, or 2 bricks, thick;  $18\frac{1}{2}$  bricks for a wall 12 or 13 inches, or 3 bricks, thick;  $24\frac{2}{3}$  bricks for a wall 16 or 17 inches, or 4 bricks, thick, and so on,  $6\frac{1}{8}$  bricks per square foot being added for every additional brick in the thickness of the wall. The estimate is then based on the number of thousands of brick, at a suitable price per thousand, including labor and mortar. For example, a wall 24 feet long, 12 feet high and 20 inches, or 5 bricks, thick, would contain  $24 \times 12 = 288$  square feet 5 bricks thick. At  $6\frac{1}{8}$  bricks this would be  $288 \times 5 \times 6\frac{1}{8} = 8,880$  brick.

**24.** The window and door openings in brick walls should always be deducted. While formerly it was in some places the custom not to deduct openings in estimating brickwork, modern

methods adopted by all careful and efficient contractors include the figuring out with exactness the number of bricks required, as above indicated. This applies with force to the quantity of mortar necessitated for the brick. If walls are built hollow a deduction is likewise made for absence of brick and mortar therein. The same is true of all flues in chimneys, the saving in brick alone paying for the cost of the flue lining which

**TABLE I**  
**NUMBER OF BRICKS TO THE SURFACE FOOT FOR**  
**DIFFERENT SIZES OF BRICKS WITH JOINTS**  
**OF VARIOUS THICKNESSES**  
 \*

Size of Brick Inches	Thickness of Joint					
	$\frac{3}{16}$	$\frac{1}{4}$	$\frac{5}{16}$	$\frac{3}{8}$	$\frac{7}{16}$	$\frac{1}{2}$
	Number of Bricks					
$7\frac{1}{2} \times 3\frac{3}{8} \times 2\frac{3}{8}$	7.31	7.08	6.86	6.65	6.45	6.26
$7\frac{3}{4} \times 3\frac{3}{4} \times 2\frac{1}{4}$	7.44	7.20	6.97	6.75	6.55	6.35
$8 \times 3\frac{3}{4} \times 2\frac{1}{4}$ *	7.22	6.98	6.76	6.55	6.35	6.17
$8 \times 4 \times 2\frac{1}{2}$	6.55	6.35	6.16	5.98	5.81	5.65
$8\frac{1}{4} \times 3\frac{3}{4} \times 2\frac{1}{4}$	7.00	6.78	6.56	6.36	6.17	5.98
$8\frac{1}{4} \times 4 \times 2\frac{1}{4}$	7.00	6.78	6.56	6.36	6.17	5.98
$8\frac{1}{2} \times 4\frac{1}{8} \times 2\frac{3}{8}$	6.47	6.27	6.08	5.90	5.73	5.57
$8\frac{1}{2} \times 4\frac{1}{8} \times 2\frac{1}{2}$	6.17	5.99	5.81	5.64	5.49	5.33
$9 \times 4\frac{1}{2} \times 3$	4.92	4.79	4.67	4.55	4.45	4.33

\*Standard size adopted by American Society for Testing Materials and The Common Brick Manufacturers' Association of America.

should invariably be used, except in the case of thick walls as mentioned in the articles on *Chimneys and Fireplaces*.

**25.** In Table I is given the number of bricks required for 1 square foot of face of a wall one brick thick—that is, having a thickness equal to the width of a brick—when laid with mortar joints of different thicknesses and bricks of various sizes.

**26.** This table will be found useful in estimating the number of bricks in any wall. To find the number of bricks per

square foot of face of a wall of any thickness, find in the table the number of bricks per square foot of face of wall for the size of brick and thickness of joint that are to be used and multiply this number by the number of bricks in thickness of the wall. The result will be the number of bricks per square foot of face of the wall in question.

**27.** For example, according to the table, if bricks  $8\frac{1}{4}$  in.  $\times 4$  in.  $\times 2\frac{1}{4}$  in. in size are to be used, with mortar joints  $\frac{3}{8}$  inch in thickness, the number of bricks per square foot of the face of the wall will be 6.36, if the wall is one brick in thickness; if the wall is two bricks in thickness, it will contain 12.72 bricks; if three bricks thick, 19.08 bricks; if four bricks thick, 25.44 bricks.

It will be observed in Table I that the two  $8\frac{1}{4}$ -inch bricks show the same number of bricks per surface foot. The reason for this is that the  $8\frac{1}{4}$ - and  $2\frac{1}{4}$ -inch dimensions are the only ones that show on the face of the wall. The  $3\frac{3}{4}$ - and 4-inch dimensions affect only the thickness of the wall.

**28. Labor Required.**—The amount of labor required for laying brick is a very uncertain quantity. An average man may lay from 750 to 1,000 bricks per day where the work is somewhat broken up and there are openings, or where the walls are thin. On thick straight walls with few openings a man may lay 1,200 to 1,500 bricks per day.

---

## BRICKLAYING

---

### TOOLS AND METHODS

**29. Tools Used in Bricklaying.**—The tools that are required in building brickwork are a two-foot rule, a long and a short plumb-rule, a level, a large steel trowel, a small steel trowel, a cutting-out hammer, a bricklayer's set, a brick jointer, wooden gauges for measuring bricks, a mason's linen line, chalk, a pencil, and leather protectors for the hand when laying wet or rough-cut bricks.

**30.** The **long plumb-rule**, or **plumb**, should be from 3 feet 6 inches to 4 feet long, about  $3\frac{3}{4}$  inches wide, and about



FIG. 1

$1\frac{1}{2}$  inches thick, with two plumb-glasses at opposite ends, like those shown at *b* in Fig. 1.

The **short plumb-rule**, or **plumb**, should be from 16 in. to 18 in. long, with one plumb-glass like that shown at *b* in Fig. 1 and one level glass, as at *a* in Fig. 1.

**31.** In Fig. 1 is shown what is known as a combination plumb-rule and level. It is used in a horizontal position as a level and the level glass *a* indicates when the level is exactly horizontal. It is used as a plumb-rule by holding one edge against the work to be plumbed and observing the level glasses *b*. A plumb-bob may be suspended from either end of the instrument so that it will hang in one of the openings *d*. The work is then tested by holding one edge of the plumb-rule against it and moving the instrument until the plumb-line coincides with the center line on the face of the plumb; then if the work does not coincide with the edge of the rule it is out of plumb or not perpendicular.

**32.** A simple form of **plumb-rule**, shown in Fig. 2, is made of a piece of board  $\frac{1}{2}$  inch thick and 3 or 4 inches in width. The edges of the board and the line *d* are parallel. A plumb-bob *b* is suspended on a cord fastened through the notches at the top of the rule and hangs in the opening *c*. When the edge of the rule is placed against a vertical surface and the line coincides with the middle line *d* on the rule the surface is plumb. A plumb-rule of this description may be easily made and is very accurate but is not so convenient as a rule with level glasses.



FIG. 2

The advantage of the leveling glasses in the plumb-rule is that the wind does not interfere with its action. In the case

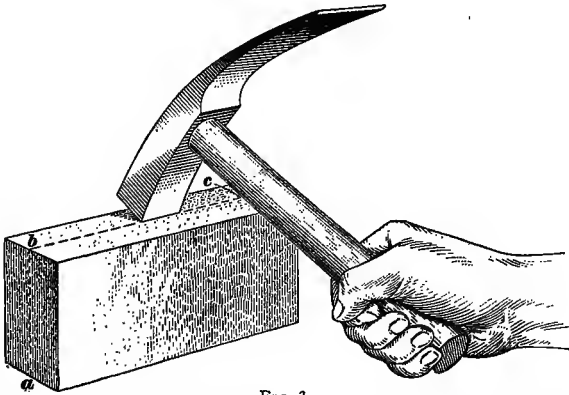

FIG. 3

of a plumb-bob suspended from a cord, even a small breeze causes motion of the bob, which interferes with its usefulness.

**33.** The principal tool used by a brickmason is the **trowel**, the form and use of which is illustrated further on in Figs. 8, 9, 10, and 11. These trowels are made from  $9\frac{1}{2}$  inches to

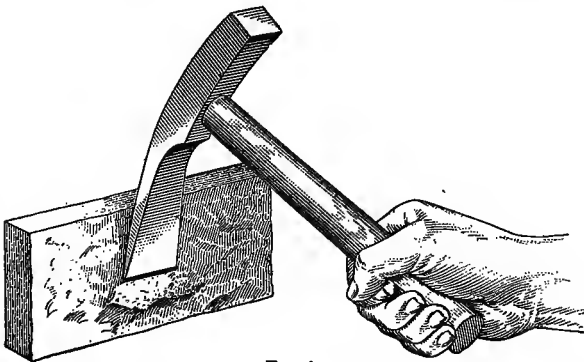

FIG. 4

11 inches in length. Pointing trowels are made from 4 to 7 inches in length.

**34.** A **cutting-out hammer** should weigh not less than  $3\frac{1}{4}$  pounds and not more than 4 pounds, exclusive of the handle. There are many types of hammers that can be used for cutting out, but the one shown in Fig. 3 will enable a first-class man to do the most work with the least fatigue. In this figure is also shown the method of splitting a brick by means of the hammer. A line *a b c* is formed around the brick by means of light blows of the hammer and then a sharp blow is given which causes the brick to split at approximately this line. Any rough places on the split faces of the brick are trimmed off by the blade of the hammer, which is called the *peen*, or *pean*, as shown in Fig. 4.

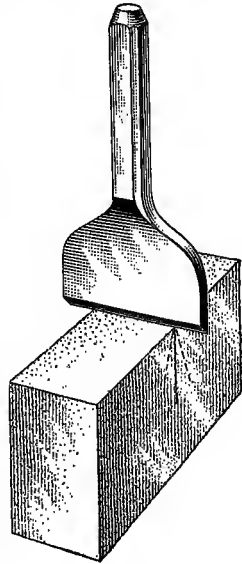

FIG. 5

**35.** A **brick set**, shown in Fig. 5, is a chisel with a broad cutting edge. It is used when it is necessary to make a cut having straight edges, so that the cut portion may show on the face of the wall, or to make plumb joints with adjacent bricks.

**36.** A **jointer**, shown in Fig. 6, is a tool that is used to form a true, even, and smooth surface on the face of the mortar between the bricks. Except where common bricks are exposed for effect this tool is not generally used, as the joints of mortar

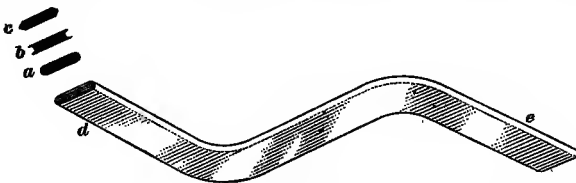
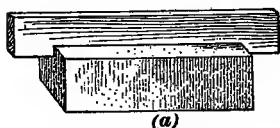

FIG. 6

are struck with the trowel as the work progresses; but a brick-mason should possess one for use in connection with such face

effects or face-brick work. Such a tool, at the very best, gets dull and loses its shape quickly, owing to the wearing action of the sand in the mortar, consequently it should be made of the hardest tempered steel that is obtainable. At *a*, *b*, and *c*, Fig. 6, are shown sections through jointers of different kinds. The edges of these jointers are curved or pointed so as to give different profiles to the mortar. The ends *d* and *e* of the jointer may have different sections, so as to be useful for striking two shapes of joints.

**37. Wooden gauges**, shown in Fig. 7 (*a*), are used to test the lengths of bricks when they are to be selected of a uniform size. The gauge shown in (*b*) is used when it is desired to cut bricks into smaller sections of uniform length. These tools are used for gauging face brick, but may frequently be used for common brick used in facing walls.



(a)

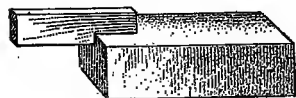

(b)

FIG. 7

**38. The line, chalk, and pencil** are familiar but indispensable implements. Pieces of leather, called *leather protectors*, are used by some mechanics to protect their

hands when they are required to handle a great number of bricks daily.

**39. Method of Laying Brick.**—In connection with the laying of brick, certain terms are used. When a brick is laid with its length in the direction of the wall, as shown at *a* in Fig. 18, it is termed a *stretcher*; a brick placed crosswise so that its end is exposed in the face of the wall as shown at *b* in Fig. 18, is called a *header*. A *course* of brick may mean one horizontal layer of brick or it may mean one horizontal layer of brick and one horizontal mortar joint.

In America, most bricks are laid in what is known as the *American bond*, which is described later in this Section. This bond consists of a layer, or course, of headers and four or five courses of stretchers, then another course of headers, etc. In building brickwork of this kind it is customary to lay the



courses on the outside of the wall first. As many as five or six courses are laid before the bricks forming the inside of the wall are put in place. These outside courses are laid up plumb and level and serve as guides for the courses on the inside of the wall.

40. The first step in laying the wall is to build a portion at each end and see that these are plumb and that the courses at each end are level with the corresponding courses at the other end.

A mason's line is then stretched between these ends to serve as a guide in laying the brick in between. In Fig. 8 is shown a mason's line *c d* and the method of attaching it temporarily to

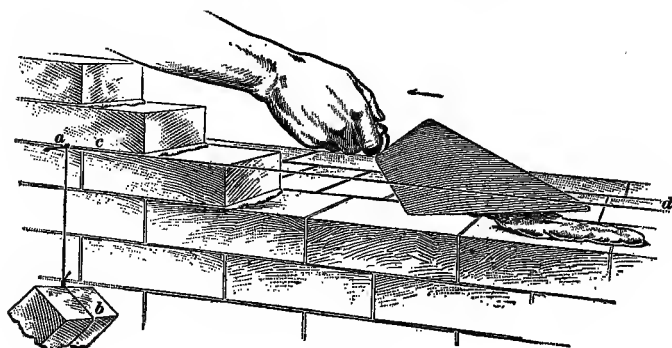

FIG. 8

the wall. This is done by driving a nail *a* into the mortar joint and winding the line around this once or twice. The line is held taut by tying a piece of brick *b* to the end. The line is secured in a similar manner to the corresponding course at the other end of the wall and bricks are laid in between so that their upper edges coincide with the line. By this method the wall is kept plumb and the horizontal joints straight and level.

When the work is interrupted for any length of time, the outer courses should not be higher than the backing, especially where face brick is used, as the mortar joints in the face of the wall will dry out too rapidly and the color of the mortar will appear different from that in other parts of the face of the wall.

41. In Fig. 8 is shown the actual process of laying brick in a 16-inch or 17-inch wall. A trowel with mortar on it is moved

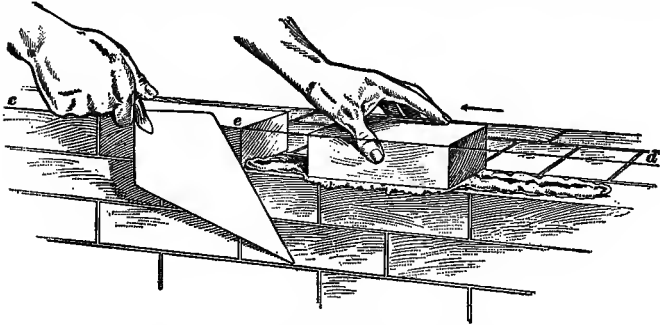

FIG. 9

over the wall in the direction of the arrow and at the same time is tilted so as to allow the mortar to slide off. This distributes the mortar over the outer course of brick in the wall. The mortar is then spread with the point of the trowel, which is drawn through the mortar with a vibrating motion of the hand which causes the mortar to form little ridges as shown in Fig. 9. A brick is then placed on this mortar bed about 3 or 4 inches away from the brick against which it is to be placed, as shown in Fig. 9, and is shoved into place as in Fig. 10. The shoving movement forces a quantity of mortar up into the vertical

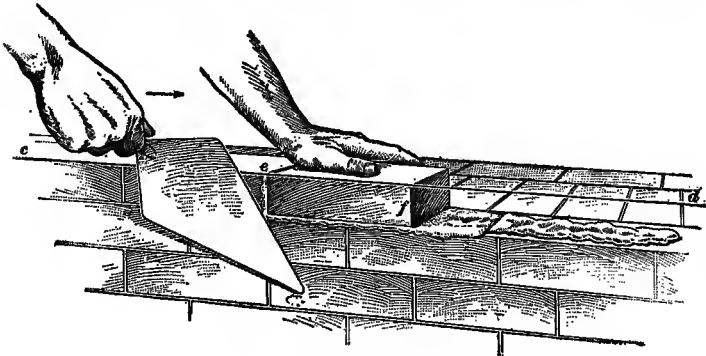

FIG. 10

joint *e*, Figs. 9 and 10, and squeezes out any excess of mortar that may be in the joints.

The upper edge of the brick should coincide with the line *c d*, which is the mason's line previously referred to. If this edge is too high, the brick is tapped down with the handle of the trowel or sometimes with the hammer until it is even with the line. If the top of the brick is below the line, the brick must be taken up and more mortar placed under it.

When the brick has been accurately placed, all the mortar which has been squeezed out while placing the brick and which projects beyond the face of the wall is removed by a stroke of the trowel as indicated in Fig. 10. This surplus mortar adheres

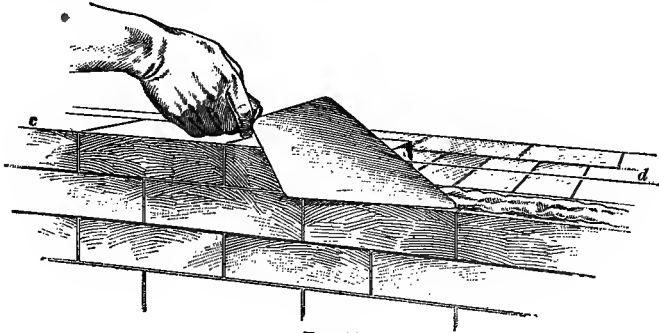

FIG. 11

to the trowel and is scraped off against the vertical edge of the brick as shown in Fig. 11.

**42.** After five or six courses have been laid on the face of the wall, the joints are all smoothed with a trowel, then the interior of the wall back of these face courses is begun.

The inside course is first laid in the manner described for the face courses and the mortar joints on the inner face of the wall are smoothed with the trowel. A bed of mortar is then placed between this course and the outer course and bricks are placed in the space quite rapidly, as it is not necessary that they be exactly placed. Bricks that are slightly chipped, warped, or that have slight defects are used in the heart of the wall with satisfactory results. Mortar is then filled in between these bricks from the top and another row, or course, is placed on top of the one just finished. Very often the joints in the interior of a brick wall are not completely filled with mortar, and where



the wall in the form of a white efflorescence which disfigures the wall.

In very hot weather the brick should be thoroughly wet with water sprayed on them from a hose. If this is not done, the brick will absorb water from the mortar, which will prevent its setting.

#### SCAFFOLDING

**45. Inside Scaffolding.**—In erecting brickwork it is necessary to build scaffolding as the work progresses. The contractor naturally uses the cheapest type of scaffold that will serve his purpose, and will always use an inside scaffold instead of an outside one if the character of the work will permit. The reason is that the floorbeams can then be used to support the scaffold and the scaffold will not have to be built up from the ground.

**46.** When a simple job of brickwork is to be done, such as a plain building, the bricks are generally laid from the inside so that the inside scaffold can be used. Boards laid upon the floorbeams serve as a scaffold for the wall up to a height of about 4 feet 6 inches. A scaffold consisting of wooden horses with planks laid upon them serves for laying the upper half of the wall of the story. This process is then repeated, the same horses and planks being used over again.

**47.** Instead of wooden horses, square wooden frames, Fig. 13, braced at the corners, are often used. These are placed in an upright position and braced with boards placed diagonally. Planks are then placed on top of these frames.

**48. Exterior Scaffolds.**—Exterior scaffolding must be used when the outside face of a wall is to have an ornamental character or be trimmed with cut stone or terra cotta.

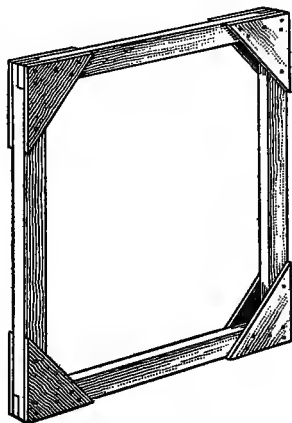

FIG. 13

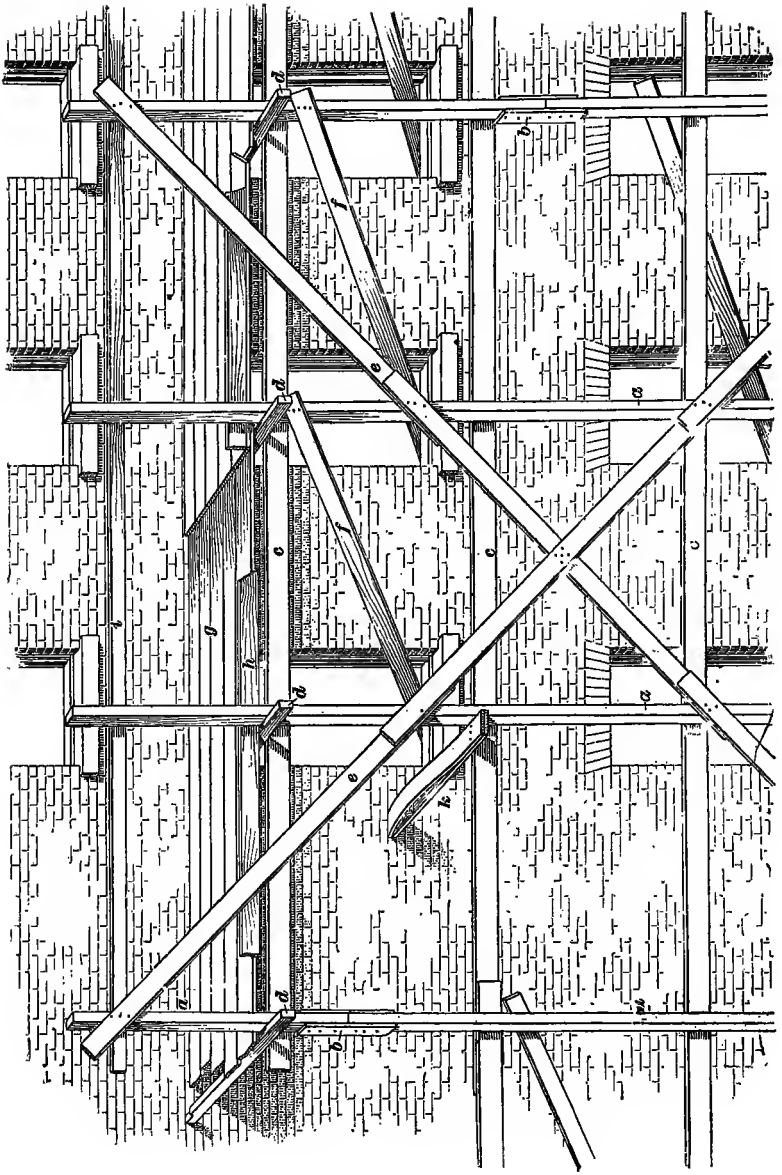

Fig. 14

The most common form of scaffolding used by masons is the **pole scaffold**. There are two types of the pole scaffold. One type depends partly upon the wall for support and the other type is built so as to be self-supporting and independent of the building.

A scaffold that receives some support from the wall is illustrated in Fig. 14. This scaffolding consists of uprights or poles *a*, which may be circular in cross-section, but which are generally in the form of small timbers, having a cross-section of 3 in.×6 in. for a five-story building and never less than 3 in.×4 in. The poles should be placed about 5 feet away from the face of the wall and about 7 feet 6 inches apart on centers. They should be firmly supported on the ground, and the lower ends should be braced so they will not slip. When they must be spliced together to make them longer, they are placed end to end and a piece of plank is nailed on each side of the joint as shown at *b*. These splices should not occur in all the poles at the same level. Ledger boards *c* are nailed to the poles to brace them horizontally and also to support the putlogs *d*, which sustain the floor of the scaffold. The other end of the putlog extends into the wall 4 or 5 inches. The uprights are braced diagonally by the braces *e* and to window frames by the window braces *f*. These latter braces prevent the scaffolding from falling away from the building.

What is known as a **spring stay** is shown at *k*. This device consists of two boards or planks, the ends of which are placed in a hole in the wall and a block is placed between them near to the wall. The block causes the boards to spread. The spread ends are brought together and nailed to the ledger. This action forces apart the ends in the wall so that they obtain a firm grip in the wall. The spring stay holds the scaffold firmly to the wall.

A platform *g*, formed of 2"×10" planks, which lap over each other at the ends, is laid on the putlogs. Foot-boards *h* are nailed on top of the platform against the uprights, also a guard-rail *i* is placed at a suitable height.

The entire structure should be thoroughly braced and well nailed with 10- or 12-penny nails.

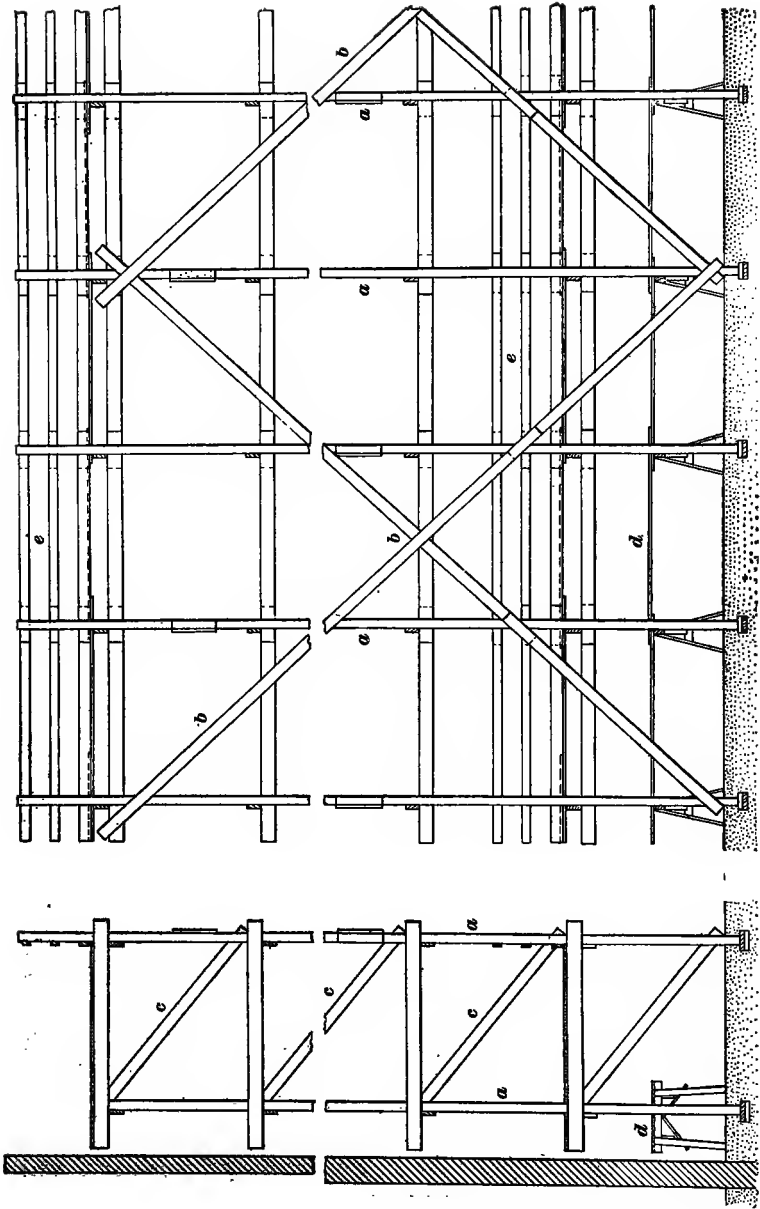

Fig. 15



**49.** A self-supporting pole scaffold is shown in Fig. 15. There are two sets of poles or uprights as shown at *a* in the side view. These are braced together, as indicated at *b* in the front view, as well as in a direction perpendicular to the wall, as at *c* in the side view. The planks of the working platform are carried on horizontal pieces which, as shown, do not touch the building. Putlogs are not used in this scaffold, as their use is likely to disfigure the face of the wall. It is always difficult properly to patch up the holes in the wall made by the putlogs, and for this reason it is desirable to use an independent scaffold. The upper part of the first-story wall is laid from the scaffold *d*, which consists of planks laid on horses. There are two guard rails shown at *e*. A scaffold of this description should not be used for a wall more than 100 feet in height.

**50.** A type of scaffold that is used when only one story of the wall, such as the cornice story, is required to be built from the outside, is formed by extending planks on edge out of the window openings and laying a platform upon them. Guard rails should be provided as in other scaffolds.

**51. Suspended Scaffolds.**—On tall, skeleton-construction buildings, suspended scaffolds are used. Steel beams called outriggers are supported on the floorbeams of the upper part of the frame of the building and project out 5 or 6 feet beyond the face of the wall. From these projecting beams the scaffold is suspended by means of wire cables. The cables are attached to the scaffold by means of devices by which the cable can be rolled up and the scaffold thus raised as required.

---

## BRICK WALLS

---

### TYPES OF BRICK WALLS

**52. Solid Walls.**—The brick wall most universally used and which is cheapest to construct is the *solid* wall. This wall consists of a solid mass of brickwork with no hollow spaces constructed in it. Such a wall is substantial, easy to build, and when properly constructed will last for centuries.

**53.** There are certain disadvantages characteristic of brick walls, and these result from the porosity of the brick and mortar. Unless a wall is built of good hard-burned brick and laid up with a properly proportioned mortar, moisture is likely to find its way through it. Some method is, therefore, generally adopted to prevent this moisture from reaching the inner surface of the brickwork, especially when plastering is applied directly to the brick.

**54.** One of these methods is to coat the inner surface of the wall with a damp-proofing compound which fills the pores on the inner surface of the wall and adheres strongly to the brickwork. At the same time this compound affords a good key for the plastering.

Another method is to form the inside 4 inches of hollow bricks or 8 inches of hollow tile, but while plastering applied directly to these surfaces will hold satisfactorily, the bonding courses of the joints are apt to become damp on the inside during wet weather.

**55.** The best and cheapest method of preventing water from reaching the plaster is to furr the walls. This may be done by nailing wooden **furring strips** about 1 inch by 2 inches in size to the inner face of the wall and nailing wood or metal lath to them to receive the plastering. Metal rods or furring may be stapled to the walls and metal lath fastened to them, or one of the several types of *self-furring* metal laths may be used. Terra-cotta furring may be applied to the entire face of the wall, such furring being held in place by the use of mortar and nails.

**56. Hollow Walls.**—Hollow walls, or more properly, double walls, are sometimes built and are intended to keep moisture from passing through, and by providing a complete separation of one wall from the other, keep the building cooler in summer and warmer in winter. Difficulties that largely offset their advantages are met with in construction, however, so that hollow walls are not often used in the United States. The objections to hollow walls are that more ground area is

required, thicker foundations are needed, the cost of construction is increased, and there is no assurance that the two walls are better than one solid wall properly furred.

**57. Party Walls.**—A party wall is a wall that separates two adjoining buildings and carries the floor and roof beams of both of them. The floor loads on party walls are twice as great as the load on any outside wall.

Building regulations in regard to the thickness of party walls are based on the span of the joists or width of building, and on the height. The specifications of the Committee on Building Construction of the National Fire Protection Association require all party walls and fire walls to be of solid masonry and almost all building codes require solid brick, not only as fire protection but to afford the property owner on each side the opportunity to insert or hang joists at any desired level or place.

**58. Fire Walls.**—The National Fire Protection Association has defined a fire wall as follows: "The term **Fire Wall** indicates a wall subdividing a building to restrict the spread of fire. In all buildings it shall start at the foundation, be continuous through all stories and extend at least 3 feet above the roof."

**59. Panel or Enclosure Walls.**—In modern skeleton construction, the floor loads in a building are carried on the steel or reinforced-concrete frame, and the walls carry no load other than their own weight. Such walls are generally supported upon girders extending from column to column, usually at every floor. In this way much thinner walls can be used, and valuable space can be saved.

The New York City Building Code provides that "masonry walls supported at each story by girders may be 12 inches thick for the entire height of the building."

The Chicago building ordinances provide that "If buildings are made of fireproof construction, and have skeleton construction so designed that their enclosing walls do not carry the weight of floors and roof, then their walls shall be not less than 12 inches in thickness."

**60. Curtain Walls.**—Following is an extract in regard to curtain walls from the New York City building laws:

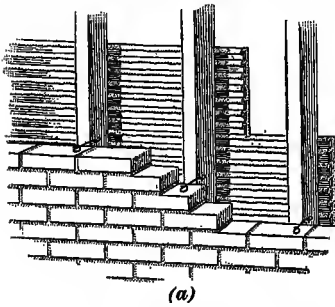

*“Curtain Walls.* Non-bearing walls built between piers or metal columns shall not be less than 12 inches thick for the uppermost 60 feet of height, increasing 4 inches in thickness for each next lower section of 60 feet.” Curtain walls are not supported by beams, but rest on suitable footings supported on the foundation soil.

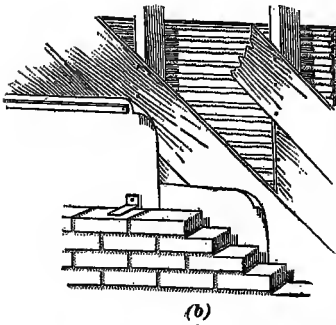

**61. Veneered Walls.** Frame houses are frequently incased in a 4-inch veneer of brick, separated from the wood by a 1-inch or a 2-inch air space. Veneered walls are generally somewhat cheaper than those built of solid brick. Houses constructed in this fashion are warmer in winter and cooler in summer, and are also less likely to catch fire from outside sources than are ordinary frame buildings.

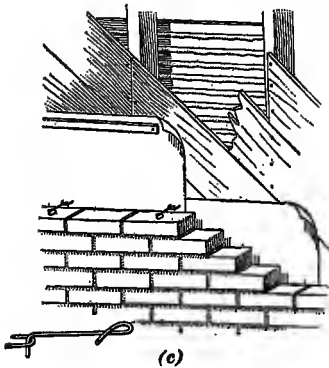

FIG. 16

**62.** In building a house with veneered walls, the foundation must project far enough beyond the line of the studs to carry the brickwork that is put on later. This requires a projection of 1 inch for sheathing, 1 or 2 inches for air space, and 4 inches for brick. The 1 or 2 inches allowed for an air space is also necessary to accommodate the mason's fingers

when he is laying the brick, and is frequently called a *finger space*.

Care must be taken to construct the frame in the best manner, for the brick veneer carries absolutely no part of the building except its own weight, and in fact has to be tied to the wood framing for support. After the frame is up it should be sheathed diagonally and the sheathing should, as a rule, be covered with tar paper or other waterproof material on the

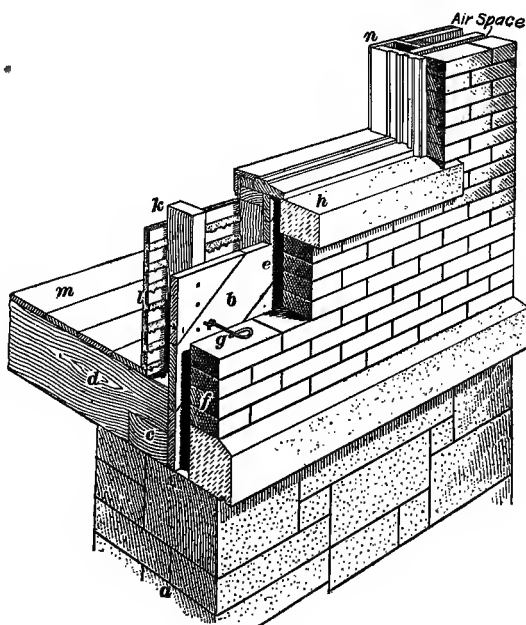

FIG. 17

outside before the bricks are laid. The sheathing is omitted in a very cheap form of construction such as is shown in Fig. 16 (a). This form of construction is not to be recommended, however. The tar paper is omitted in Fig. 17 for the sake of clearness. All the framing timber, particularly the sills, should be as dry as possible, and the frame must be perfectly plumb and straight; if not, the brick veneer will not lay up properly.

The brick veneer is usually tied to the diagonal sheathing or

to the studs with metal ties. The wire tie, shown in Fig. 16 (*a*) and (*c*), is most generally used, though a tie made of No. 16 iron,  $1\frac{1}{4}$  inches wide, with the end turned up, as shown in Fig. 16 (*b*), gives satisfactory results. The ties are generally placed on every other brick in every fifth course of brickwork.

**63.** Fig. 17 shows a section through part of the foundation of a veneered building and the principal features of its construction. At *a* is shown the stone foundation wall, projecting 6 inches beyond the diagonal sheathing *b*; the 4"×6" sill is shown at *c*, the 2"×10" floor joists at *d*, and the air space between the brickwork and the sheathing at *e*. The 4-inch brick-veneer wall is shown at *f*, and the wire tie at *g*; the stone window sill is shown at *h*, the 2"×4" studding at *k*, the lathing at *l*, the flooring at *m*, and the window frame at *n*.

Due to the fact that any stability which a 4-inch brick veneer receives is dependent upon metal ties, which may rust, attached to a wooden building which may vibrate and will burn, this type of construction is not to be recommended, especially for any height above two stories.

**64. Veneering on Hollow Tile.**—Brick, especially face brick, may be used as a veneer on hollow building tile or back-up blocks. A wall of this description is generally damp-proof, and plastering can be applied to the inside face of the terra cotta without the danger of dampness affecting it. Such walls will be more fully described later in the Section on *Hollow Tile*.

---

#### THICKNESS OF WALLS

**65.** The thickness of walls in brick masonry is a matter that cannot be determined by calculations. Experience must be followed and also the regulations laid down in the building codes of different cities. The latter is the better plan, as the stipulations given in these codes are the result of experience of many men, and there are thousands of buildings to show the successful application of the rules given in these codes.

**66. According to the New York City Building Code.**—The New York Building Code makes the following

provisions for structures where the walls are entirely of brick and support the floors and roofs, and where no steel columns or beams are built into the walls:

*Residence Buildings.*—Except as otherwise provided, the thicknesses of brick walls of residence buildings hereafter erected shall be not less than the following: (a) When over 75 feet in height, 12 inches for the uppermost 25 feet, 16 inches for the next lower 35 feet, 20 inches for the next lower 40 feet, with a 4-inch increase for each additional lower section of 40 feet; (b) when not over 75 feet in height, 12 inches for the uppermost 55 feet, and 16 inches below that.

*Public and Business Buildings.*—Except as hereinafter provided, the thickness of masonry (brick) walls of public and business buildings hereafter erected shall be not less than the following:

(a) When over 75 feet in height, 16 inches for the uppermost 25 feet, 20 inches for the next lower 35 feet, 24 inches for the next lower 40 feet, and increasing 4 inches for each additional lower section of 40 feet.

(b) When over 60 feet and not over 75 feet in height, 16 inches for the uppermost 50 feet, and 20 inches below that.

(c) When over 40 feet and not over 60 feet in height, 12 inches for the uppermost 20 feet, and 16 inches below that.

(d) When not over 40 feet in height, 12 inches throughout.

*Increased Thickness When Required.*—(a) Every bearing wall with face brick bonded with clip courses or ties, and every bearing wall faced with ashlar, shall have a total thickness of at least 4 inches more than otherwise required unless the ashlar is at least 8 inches thick in every alternate course and bonded to the wall:

(b) When the clear span between bearing walls is over 26 feet, such walls shall be increased 4 inches in thickness for every  $12\frac{1}{2}$  feet or part thereof that said span is over 26 feet.

(c) All walls over 105 feet long between cross-walls or proper piers or buttresses, shall be increased in thickness over the minimum requirements at least 4 inches for every 105 feet, or part thereof, over 105 feet in length.

(d) If the horizontal section through a bearing wall shows more than 30 per cent. area of flues and openings, such part of the wall where the excessive openings exist shall be increased 4 inches in thickness over minimum requirements for every 15 per cent. or fraction thereof, of flue or opening area in excess of 30 per cent.

*General Reservations.*—Nothing in these laws shall prevent the use in any wall of the same amount of material in piers and buttresses as is required for the thickness prescribed.

The unsupported height of any wall or part thereof shall not exceed 20 times the thickness of such unsupported part, unless reinforced by adequate cross-walls, buttresses, or columns.

**67. According to the Chicago Building Ordinances.**—The ordinances of Chicago group buildings into several classes and specify certain conditions that apply to these different classes. Where the walls of the buildings are entirely of masonry and support the floors and roof, the following general regulations are prescribed:

Brick, stone, and solid concrete walls, except as otherwise provided, shall be of the thickness in inches indicated in the following table:

Number of Stories in Building	Story												
	Basement	1	2	3	4	5	6	7	8	9	10	11	12
	Thickness of Wall, in Inches												
One.....	12	12											
Two.....	16	12	12										
Three....	16	16	12	12									
Four.....	20	20	16	16	12								
Five.....	24	20	20	16	16	16							
Six.....	24	20	20	20	16	16	16						
Seven....	24	20	20	20	20	16	16	16					
Eight....	24	24	24	20	20	20	16	16	16				
Nine.....	28	24	24	24	20	20	20	16	16	16			
Ten.....	28	28	28	24	24	24	20	20	20	16	16		
Eleven...	28	28	28	24	24	24	20	20	20	16	16	16	
Twelve ..	32	28	28	28	24	24	24	20	20	20	16	16	16

There are modifications in these thicknesses that may be made under certain conditions, and when building where this code is in force a copy of the ordinances should be obtained and carefully followed. For instance, certain provisions are made for the use of 8-inch or 9-inch walls in dwellings and other small buildings, and these and other provisions must be complied with where such laws are in force.



### BOND IN BRICKWORK

**68. Necessity for Bond.**—To build a strong, substantial, and solid wall with such small pieces of material as bricks, requires a careful arrangement of the bricks in the body of the wall so that they shall be tied together and form a cohesive mass of masonry. Tying the bricks together is done partly by good mortar and largely by proper bonding. **Bonding** may be described as the process of laying bricks so that one brick shall rest on parts of two or three bricks below it. The *bond* in a wall is the result obtained by *bonding*. Brickwork that is not

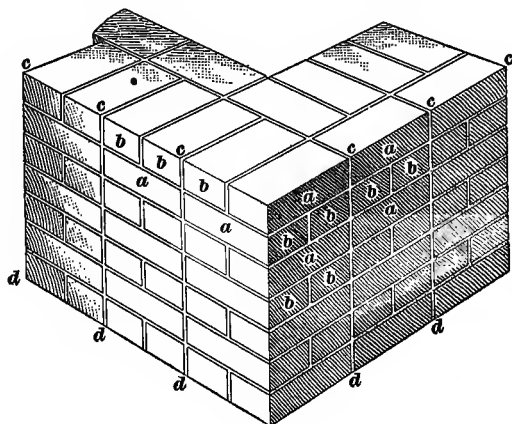

FIG. 18

properly bonded is shown in Fig. 18. By placing the brick in this manner, the wall is merely a series of piers that abut each other on the lines *c*, *d* and have no bond or union between them other than that obtained by the adhesion of the mortar.

The object of the standard bonds, that will be described presently, is to tie the wall together both longitudinally, or in the direction of the length of the wall, and transversely, or in a direction perpendicular to the face of the wall. The best brickwork is that in which the bricks are most thoroughly tied or bonded together, both lengthwise and crosswise, as well as vertically.

**69. Terms Used in Bonding.**—When brick are laid lengthwise in the face of a wall, as at *a* in Fig. 18, they are termed **stretchers**. When placed crosswise so that their ends are exposed in the face of the wall, as at *b*, they are called **headers**. A **course** means a horizontal layer of brick or one horizontal layer of brick and one horizontal mortar joint. Parts of bricks, that are made by cutting the whole brick, are called **bats** or **closers**. The different bats used in brickwork are shown in Fig. 19. A whole brick is shown in (*a*). When a brick is cut longitudinally, as in (*b*), on the line *a b*, each half is called a **queen closer**. It is difficult, however, to cut a brick in this manner, hence it is first cut on the line *c d e* and

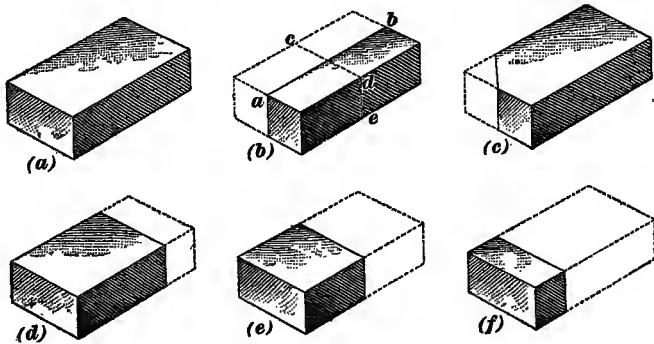

FIG. 19

each half is cut along the line *a b*. When a brick is cut as in (*c*), it is called a **king closer**. When one-fourth of a brick is cut off as in (*d*) the remainder is called a **three-quarter bat**. In (*e*) is shown a **half bat** and in (*f*) a **quarter bat**. A **closer** is a bat used to fill up a space near the end of a wall, resulting from the longitudinal bond used in the wall. Closers are illustrated in Fig. 20 at *c*.

**70.** Bonding is accomplished by lapping one brick over portions of two or more bricks in the course below. This process is often referred to as **breaking joints**. The vertical joints should not come one above the other in the face of the wall as shown in Fig. 18, but should alternate as shown in Fig. 20. This is done systematically so that the vertical joints shall

occur in plumb lines. The vertical joints in one course should be kept perpendicular, or directly over those in the second course below.

The joints in both faces of the wall should be directly opposite each other. This arrangement of the joints in the top of the wall is shown in Figs. 16, 21, 22, etc.

#### STANDARD BONDS

**71.** In the course of time there have been developed several standard methods of bonding brickwork such as the English, Flemish, American, Running, etc. bonds.

**72. English Bond.**—The **English bond** is probably the best and strongest method of bonding brickwork. In this

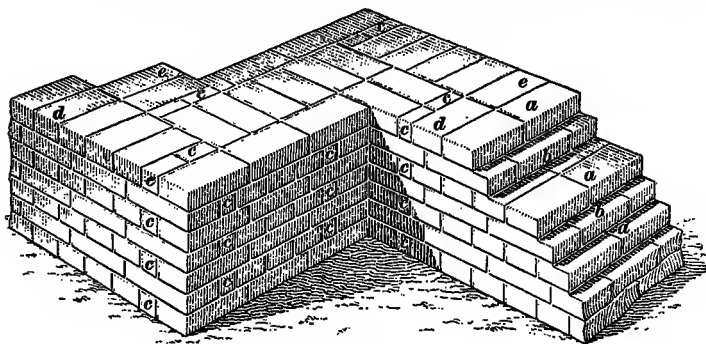

FIG. 20

bond, header and stretcher courses are laid alternately, as shown in Fig. 20. Joints are broken in the longitudinal bond courses by the use of quarter-bat closers, marked *c*. This is without doubt the best and simplest bond to use in all work where strength is required, as by its use a complete and thorough transverse bond is formed. It will be observed that the heart of this wall, which is about 16 inches thick, consists entirely of headers, and that the joints of the header course, as at *a*, are well bonded by the headers *b* of the stretcher course.

**73.** The wall shown in Fig. 20 has only two different courses. The arrangement of the bricks in these courses is

shown in Fig. 21 in courses *A* and *B*. By studying these plans in connection with Fig. 20 there should be no difficulty in understanding the construction of the wall. At *c* are shown

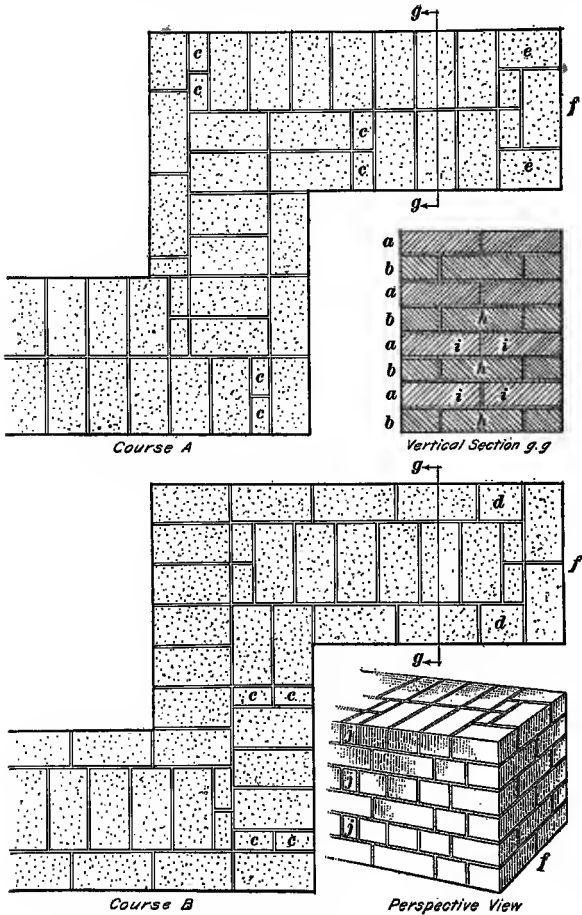

FIG. 21

queen closers; at *d*, half-bats; and at *e*, three-quarter bats. These latter are used in forming the end *f* of the wall.

In the vertical section through the wall taken through *g g* are shown the cross-ties formed by the bricks *h* lapping over

the bricks *i*. The perspective view shows the arrangement of the bricks in the face of the wall. The closers are shown at *j* and the end of the wall at *f*.

**74. Flemish Bond.**—The **Flemish bond** is one in which each course is composed of alternate headers and stretchers. The method of laying the bricks in this bond is illustrated in Figs. 22 and 23. Bats *a* and *b* are used at the corners of the walls and at *c* on the interior of the wall. In this example the headers and stretchers on the inner face of the wall are exactly opposite those on the outer face, and the wall is said to be built in **double Flemish bond**. The vertical section is taken through *e e* on the plans of the courses

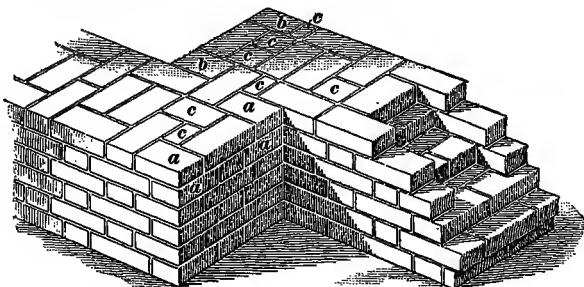

FIG. 22

*A* and *B* and shows the bond. The perspective view shows the appearance of the bond in the face of the wall and the jamb *f*.

**75. American, or Common, Bond.**—The bond most extensively used in the United States is known as the **American, or common, bond**. It is, in fact, a modification of the English bond. Instead of making every other course of brick a header course, as in the English bond, every fifth, sixth, or seventh course is made a header course in the American bond, with stretcher courses in between. This construction is illustrated in Fig. 24. Plans of the different courses are shown in Fig. 25, in which (*a*) and (*b*) are the courses that form the cross-bond, and (*c*) and (*d*) the stretcher courses in between. The arrangement of these courses is shown in the vertical sections (*f*) and (*g*).

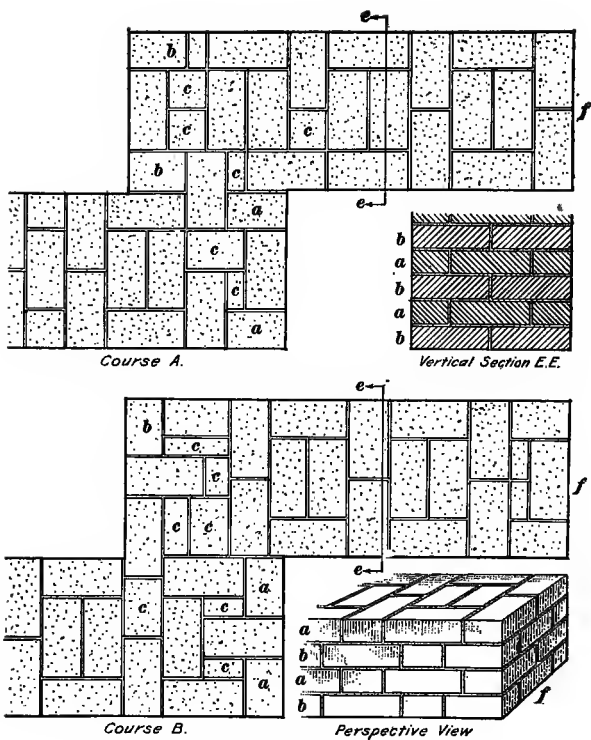

FIG. 23

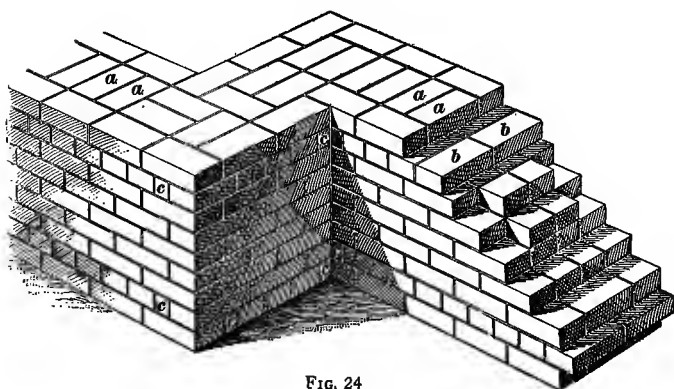

FIG. 24

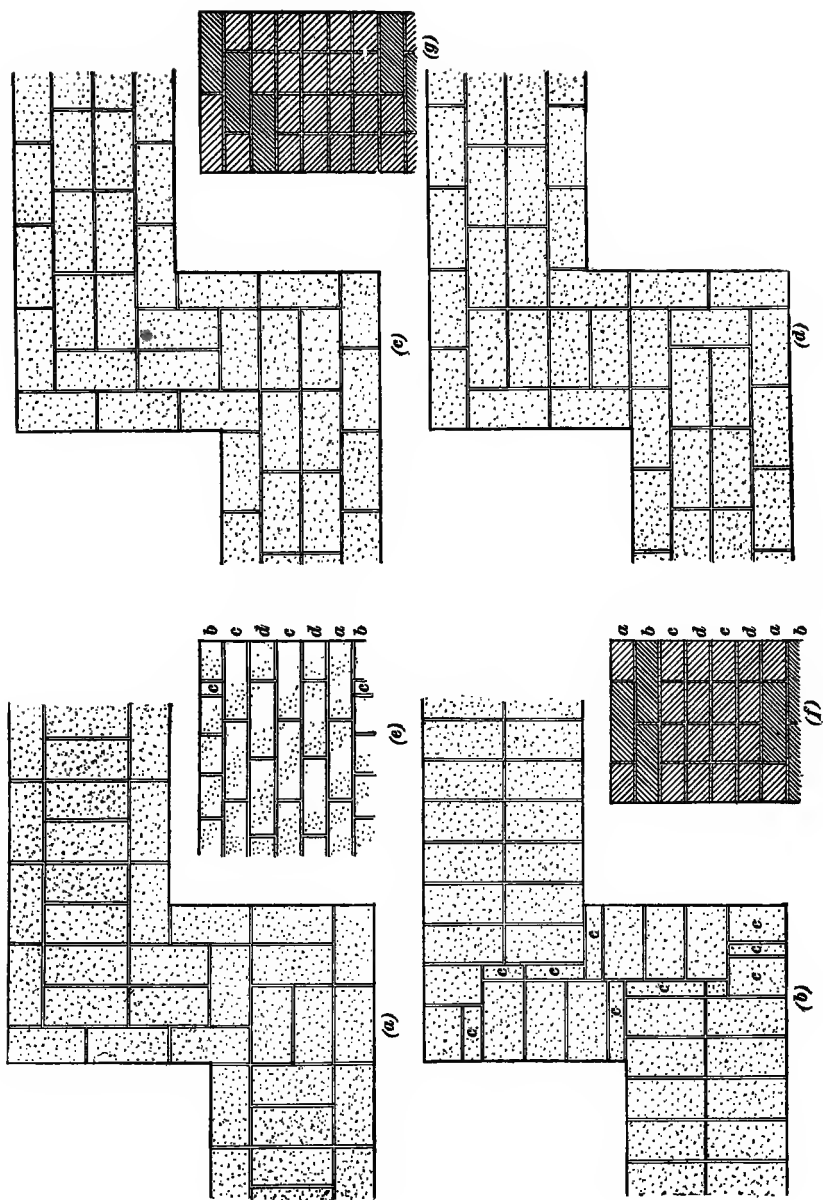

FIG. 25

The bond shown in (*f*) is formed by the two header courses *b* placed at the same level on the outside and inside faces and a course *a* lapping over both headers. This treatment brings the heading courses at the same level on both sides of the wall.

In (*g*) is a slightly different arrangement which is often used. In this case the header course on one side of the wall is lower than the header course on the other side.

The courses (*a*), (*b*), (*c*), and (*d*) are laid out according to the section (*f*). The arrangement of the bricks in the face of the wall is shown in (*e*). This form of bonding makes a wall that can be quickly and therefore cheaply built.

**76.** American bond is generally used in the United States not only for building walls of common brick, but also for backing up terra cotta, stone, and face brick. In fact the backing up is the real wall that not only supports the floor and roof loads, but also the weight of the facing.

The New York building laws require that every sixth course shall be a header course; that is, that five courses of stretchers must come between two courses of headers. For factory and warehouse purposes, where the walls have to sustain heavy weights, it is better to have every fourth course a header course, thus giving three courses of stretchers between the header courses.

---

#### BONDING FACE BRICK

**77. Stretcher or Running Bond.**—When a facing of brick is applied to a wall of common brick it is necessary to tie the facing firmly to the *backing*, or common-brick wall. This is done in different ways. When the facing is in running or stretcher bond there are no headers appearing in the face of the wall. In this case galvanized metal ties are generally used as shown in Fig. 26.

**78. Face Bonds.**—English and Flemish as well as other ornamental bonds are often used as facings only and are secured or bonded to a wall that is laid up in American or common bond. This can easily be done by extending some of



the numerous headers of the face bonds into the backing and thus securing an ample tie. The remaining headers will be composed of half-bricks or bats.

**79. Metal Ties for Brickwork.**—Fig. 26 illustrates the method of bonding in face brick with steel or galvanized-iron

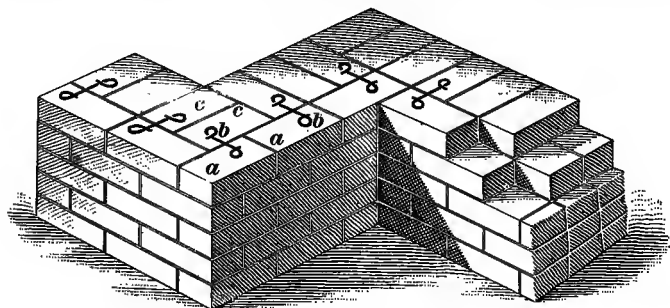

FIG. 26

wire. These wire ties *b* are twisted at the ends, and hold together the inside and outside courses *a* and *c*, as shown. They are laid in every sixth course of brick.

A still better method of tying front brick to the common brick in the rear of the wall is by the use of galvanized steel

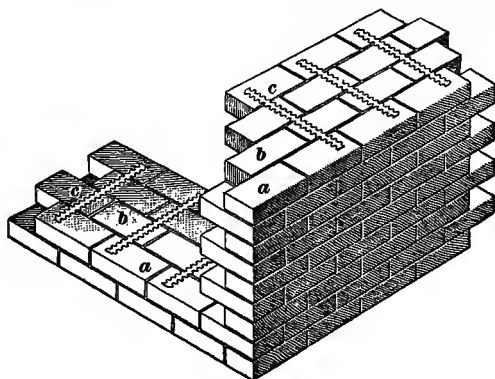

FIG. 27

ties from  $\frac{3}{32}$  to  $\frac{1}{8}$  inch thick, and having some of the metal punched out. The brick may be brought down to a very close joint, and the clinching edges make a very firm and satisfac-

tory binder. Fig. 27 shows the application of these bonding strips. Here, *a* is the pressed-brick facing, *b* the common brick in the rear of the wall, and *c* the steel ties bonding the pressed brick to the common brick.

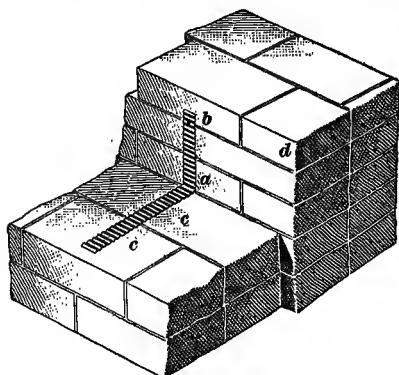

FIG. 28

Similar ties can be used for tying a new wall to an existing wall to increase its strength. The tie is bent near the middle, as shown at *a* in Fig. 28, and is nailed to the old wall with pointed wrought-iron nails, shown at *b*. These nails have

large flat heads made especially for this work, and are of sufficient size to make a firm connection for the new courses *c*.

Other forms of metal ties that are on the market are shown in Fig. 29. In using such ties it is generally advisable to use those that are sold in the local market.



#### BONDING HOLLOW WALLS

80. Before the introduction of metal ties, the bond between the two walls which form the hollow or double wall was accomplished with brick which were embedded in both walls and extended between them, tying them together.



FIG. 29

Before the introduction of metal ties, the bond between the two walls which form the hollow or double wall was accomplished with brick which were embedded in both walls and extended between them, tying them together.

This method was very expensive, as it required considerable cutting of brick. It also reduced the effectiveness of the hollow wall, as it provided places in the bonding brick through which dampness might pass.

**81. Bonding With Metal Ties.**—Bonding hollow walls by the use of metal ties is the cheaper and probably the better method, provided the ties are thoroughly protected from cor-

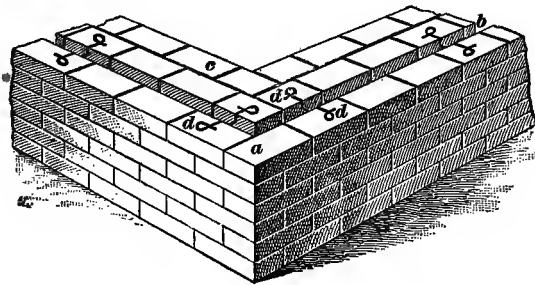

FIG. 30

rosion by galvanizing. These ties make the hollow wall effective, as the ties will not carry moisture to the inner wall.

At *a*, Fig. 30, is shown a 4-inch wall; at *b*, the air space; at *c*, the inner 8-inch wall; and at *d*, the metal ties. It should be said that hollow walls are not built very frequently, as the same results can be obtained at less cost by using hollow terracotta tile, called back-up tile, with a veneering or facing of brick.

#### BONDING WALLS AT ANGLES

**82.** In building brick walls, it is necessary that the angles in the walls be properly bonded. When the two walls forming the angle are carried up at the same time, the bonding at the corners is easily effected; if, however, one wall is built first, due to a delay in getting materials required for the other wall, particular care must be taken that the two parts will bond together properly.

In such cases, the wall first built is generally left toothed, as shown in Fig. 31.

In order to unite the two walls more firmly, anchors made of  $\frac{3}{8}$ " $\times$ "2" wrought iron, with one end turned up 2 inches and the other turned around a  $\frac{5}{8}$ -inch bar, should be built into the side wall about every 4 feet in height, as shown at *b*,

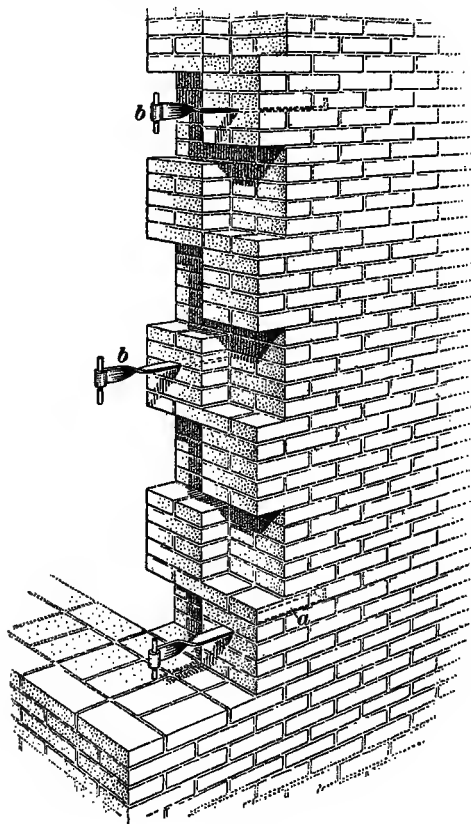

FIG. 31

Fig. 31. These anchors should be long enough to extend at least 12 inches, or the depth of one and one-half bricks laid the long way, as shown at *a*, into the side wall, and the center of the  $\frac{5}{8}$ -inch bar should be about 8 inches from the back of the front wall,

### JOINING NEW WALLS TO OLD WALLS

**83.** In joining a new wall to an old, a groove should be cut perpendicularly in the old wall, usually the width of a brick, so as to make a joint; this is called a *slip joint*.

This method of bonding is shown in Fig. 32. At *a* is shown the groove or chase cut where the new wall is to enter in the old wall; *c* is the new wall, and *d* the old wall.

In cheap construction, where new work is bonded into old, the method most commonly used is to nail a piece of

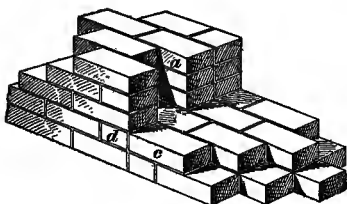

FIG. 32

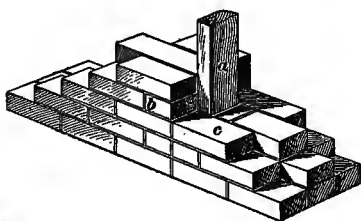

FIG. 33

2"×4" timber against the wall, as shown in Fig. 33, where *a* shows the 2"×4" timber spiked to the old wall and entering the center of the new wall. At *b* is shown the old and at *c* the new wall.

### OPENINGS IN WALLS

**84. Openings in Solid Walls.**—When a brick wall contains door and window openings, their location and relative position should be very carefully considered, not only with regard to convenience and symmetry, but also with regard to their effect on the strength of the wall. When walls are broken frequently by windows and other openings, cracks are more likely to occur than when the wall is plain and unbroken. This is owing to the unequal pressure on the wall. If walls are well bonded and anchored, the danger of cracks will be reduced to a minimum. When possible, the window openings in the different stories should be placed directly over one another.

Unless absolutely necessary, the placing of windows under a pier or directly over a narrow mullion should be avoided. When such a design must be used, brick arches or metal beams, or both, should be built in if the span is great or the arch a *flat* one.

In any bearing wall carrying the ends of floorbeams, the combined horizontal area of openings should not be more than one-third the total horizontal area of the wall, unless the thickness of the wall between the openings is increased by the use of pilasters, or buttresses.

**85. Relieving Arches.**—Openings may be spanned at the top by means of arches or lintels. Lintels cannot be made

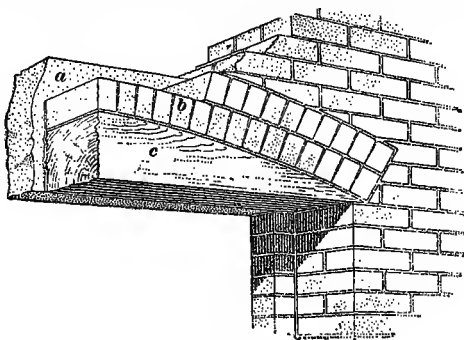

FIG. 34

of brickwork and are generally made of stone or reinforced concrete or a combination of metal and brick as described in the preceding article. When stone lintels are used they are generally only 4 inches in thickness and the remaining thickness of the wall must be supported either by steel or by brick **relieving arches**, such as shown in Fig. 34. These arches *b* are built upon solid wooden centers *c*, which are left in place after the arch is completed. The stone lintel is shown at *a*. Bricks laid in the manner shown at *b* are called *rowlocks*, and such arches, being made of two or more rows of rowlocks, are called *rowlock arches*.

### BRICK ARCHES IN GENERAL

**86.** Arches should be laid up in cement mortar by careful and experienced workmen, or otherwise there is danger of the arches failing and letting down the weight imposed on them.

**87. Definitions of Terms.**—The following definitions of terms used in connection with arches are given. They may be readily understood by referring to Fig. 35.

**Span.**—The distance between the abutments, as shown at *a b*. The word *span* is also used to mean the material construction that spans, or covers, an opening or a gap.

**Springer, or Skewback.**—The stones or bricks that lie

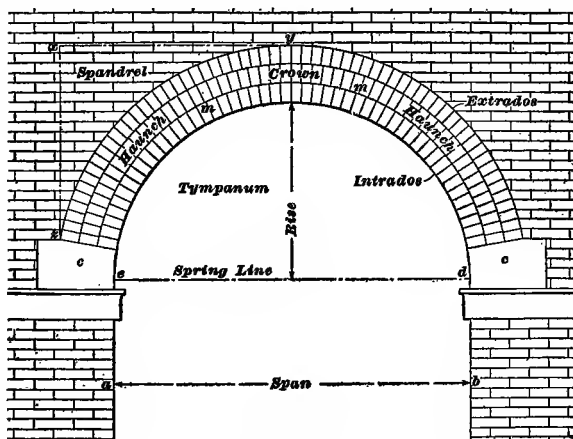

FIG. 35

immediately on the impost, as at *c, c*, from which the arch proper springs.

**Spring Line.**—A line drawn through the points where the arch intersects the abutments, or where the vertical supports of the arch terminate and the curve begins, as shown at *e d*.

**Intrados.**—The lower concave surface of the arch, formed by the under sides of the bricks, although considered by some authorities to be the concave line at the edge of the under side of the bricks.

**Soffit.**—The lower surface of the arch, or the intrados.

**Extrados.**—The upper convex surface of the arch formed by the outer sides of the bricks in the arch; also, considered by some authorities as the convex line of the curve of the outside of the arch.

**Rise.**—The perpendicular distance from the spring line to the highest point of the intrados.

**Arch Ring.**—The arch itself, contained between the intrados and the extrados.

**Crown.**—The highest portion of the arch.

**Haunches.**—The portions of the arch included between the crown and the skewbacks.

**Tympanum.**—The space between the spring line and the intrados.

**Spandrel.**—The triangular wall space included between the extrados, a horizontal line drawn through the top of the

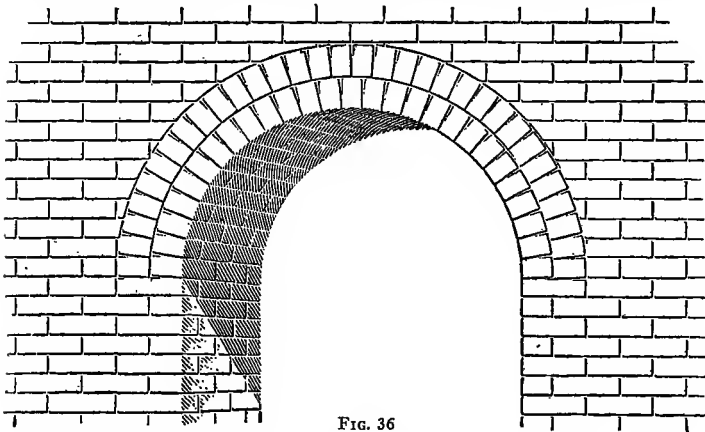

FIG. 36

extrados, and a vertical line drawn through the lower extremities of the extrados. This term is also applied to the space between two arches in a series of arches. The spandrel is shown at *z x y*.

**Spandrel Filling.**—The brickwork filling the spandrel.

**Rowlock.**—One of a series of arch courses, or rings, shown at *m, m*. There is no bond between these rings other than that afforded by the adhesion of the mortar.



**88. Construction of Arches.**—When semicircular arches are constructed of common bricks, the bricks are laid close together on the intrados, with wedge-shaped joints on the face of the arch; that is to say, the mortar joints are wider at the upper surface of the brick ring than at the lower surface, so that there is more mortar at the top of the joint than at the bottom.

Fig. 36 shows a semicircular arch consisting of two rings of rowlocks. These arch bricks are all laid as headers, and the long edges of the bricks show in the soffit of the arch. The increase of the thickness of the mortar in the joints is shown in the illustration.

**89.** Arches made of common brick are generally rowlock arches, and the difference in thickness of the joint in a distance of the width of one brick is not objectionable. An arch formed of bricks set with the length in the direction of the radius would require a decidedly greater thickness of joint toward the extrados than at the intrados. It is sometimes desired to use brick in this manner in connection with rowlocks in order to form a bond in the arch. In such cases it is necessary to have the bricks made to a radius, or wedge-shaped. Such bricks are called *gauged* or *shaped* bricks.

**90. Gauged Bricks.**—Fig. 37 shows a semicircular arch constructed of *gauged*, or *shaped*, bricks. The gauging, or shaping, may be accomplished by laying out the arch ring on a floor, and cutting, rubbing, or grinding the bricks to a certain gauge, or pattern, so that each brick will fit exactly in the place chosen for it; and all the mortar or radial joints will be of the same thickness throughout. This process is, however, expensive, and where there are many arches the brick should be molded in the required shape when manufactured.

In the example shown in the illustration, the space under the arch is filled by a brick wall supported on a bluestone lintel. This allows the bronze doors underneath to be made square on top.

As seen by the illustration, the extrados of the arch is stepped into horizontal steps. This is done so that the bricks



FIG. 37

in the wall will not have to be cut down to a knife edge in order to make them fit the work.

When the *reveal*, or space between a window or door frame and the outside of the wall, is only 4 inches, gauged-brick arches do not usually have any bond in the body of the wall except where metal ties are used; therefore, the bricks in the arch should be laid with great care and accuracy.

The class of work shown in the illustration is not often done in common brick, but is sometimes required in that material. The illustration shows the forms of bricks that will be required in such cases.

#### CHASES AND FLUES

91. Vertical grooves called *chases* and *flues* are frequently built in brick walls to receive plumbing, gas or heat

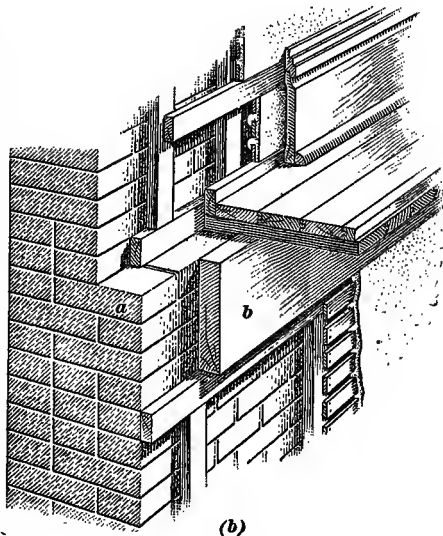
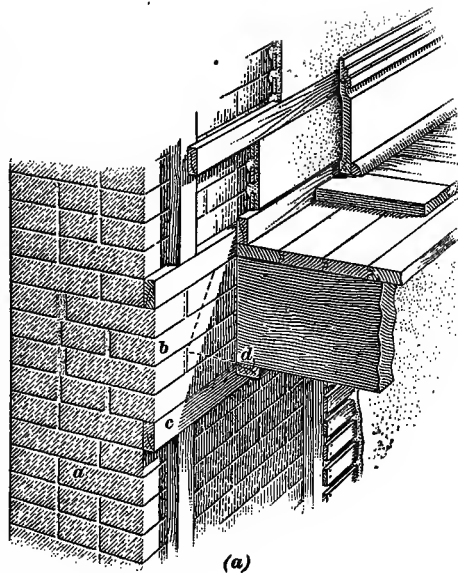

FIG. 38

pipes, etc. The building laws in some cities limit the number and size of chases that may be used in brick walls. For instance, the ordinances in force in New York City require that pipe chases shall not extend into any wall for more than one-third of its thickness and shall be not more than 4 feet in length measured horizontally. In the same ordinances, the areas of chases are counted in the areas of openings.

**92. Fire-Stops.**—Brickwork may be used to advantage as **fire-stops** to prevent the passage of flames from one floor to another back of the plastering. Brick walls are generally furred 1 inch, and this space, if continuous from floor to floor, permits the rapid spread of flames through the building.

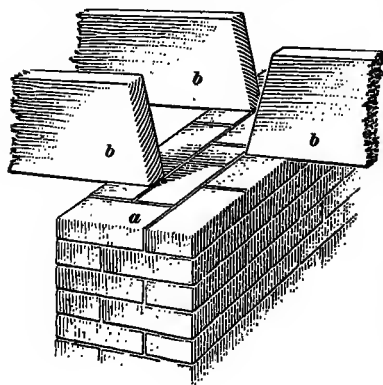

FIG. 39

Fig. 38 indicates a method of corbeling out the wall at the floor joists so as to close entirely the space between the wall and the plaster. At *a* in (a) is shown a wall of uniform thickness with the brick corbelled out at *b* for a fire-stop. A furring strip *c* makes a close joint with the cross-furring strip *d*. In (b) the brickwork sets back 4 inches, as the wall decreases in thickness at that point, as at *a*, and *b* is a joist parallel to the wall. The wall should be carried up the full thickness to the top of the joists, and this will close all passages from floor to floor back of the plastering.

Where fire or party walls occur, the joists or beams should not be placed directly opposite each other, but should be staggered, as shown in Fig. 39. For adequate protection not less than 6 inches of brickwork should separate the ends of wooden joists. In Fig. 39 *a* represents a 12-inch wall supporting 2-inch joists on 16-inch centers. The joists *b* bear 4 inches on the wall and their ends are separated about  $7\frac{1}{2}$  inches. With 3-inch joists similarly placed the ends of the

joists would be separated about  $6\frac{1}{2}$  inches. Particular care should be taken to fill all joints in the brickwork with mortar, as unless this is done fire will find its way through from the end of one joist to the end of the other. In some cases it is difficult to secure 6 inches of brickwork between the ends of the joists, and in some cases steel beams may be used to secure the proper fire protection.

---

### BACKING UP

**93.** As has been stated, common brickwork is frequently used in *backing up* stonework, terra cotta, and face brick. When this work is to be done, the stonework and terra cotta should be designed so that the heights of the courses shall be equal to the height of a definite number of brick courses, in order that the anchors or metal ties can extend back into the wall properly. For instance, with a customary size of brick, one course is counted as measuring  $2\frac{1}{2}$  inches. The stone or terra cotta should be laid out in courses that are multiples of  $2\frac{1}{2}$  inches in height. For instance, stone or terra-cotta courses should be made  $7\frac{1}{2}$ , 10,  $12\frac{1}{2}$ , 15, or  $17\frac{1}{2}$  inches in height.

When a wall is faced with face bricks of other size than the common bricks used for backing, if the joints of the face brick are kept fine and those of the common brick thick, or vice versa, the courses will work out to the same height and permit of easy bonding every five to seven courses. As some Building Codes require frequent bonds, their provisions should be ascertained and bricks selected accordingly.

The same precaution should be taken in designing stone quoins, such as are used at corners of walls. The quoins should be designed to be a certain number of courses in height so that the bed joints of the stone will coincide with the joints on the brickwork.

---

### EFFLORESCENCE

**94.** Very often, on buildings of stone or brick, more particularly the latter, white stains will appear on the surface of the walls after a few days of wet weather. These stains are

called **efflorescence**, and are due to certain soluble substances in the brick or mortar, or both. Carbonate of soda appears most frequently on new walls, and is due to the action of the lime in the mortar upon the silicate of soda in the bricks. Silicate of soda seldom occurs in bricks unless a salt clay is used in making the bricks. Sulphate of magnesia is formed when the clay contains pyrites, or when sulphurous coal is used for burning.

Water may reach the interior of the wall through absorption by the brick, through cracks and unfilled joints in the brickwork, through joints in the upper surfaces of copings or projecting courses, or from leaking or overflowing gutters and leader pipes back of the wall. When once the surface of the wall is penetrated, the moisture follows the joints and percolates to lower levels and to the outside surfaces, finally depositing the soluble substances by evaporation as stains or efflorescence.

Efflorescence may be prevented by the selection of impervious brick free from soluble materials, by filling all joints with mortar, by providing the upper surfaces of copings and projecting courses with overhanging coverings having drips, and by the proper design and maintenance of gutters and leader pipes.

Usually it is possible to remove efflorescence by washing the walls with a dilution of muriatic acid in 20 parts of water, which must be afterwards washed off with clean water. Several preservative coatings are designed to be applied to the walls after they are cleaned and dried. These preparations, by closing the pores in the brickwork, prevent the absorption of moisture. To be permanently effective, however, several coats must usually be applied, followed by additional coats at 2- or 3-year intervals.

### HANGERS, ANCHORS, ETC.

**95.** The use of joist and girder hangers, etc. simplifies greatly the work of framing, both for house and mill construction. With these hangers and anchors, a good and firm bearing may be had in brick walls. The chief requisite of a good hanger is that it shall hold firmly to the wall and at the same

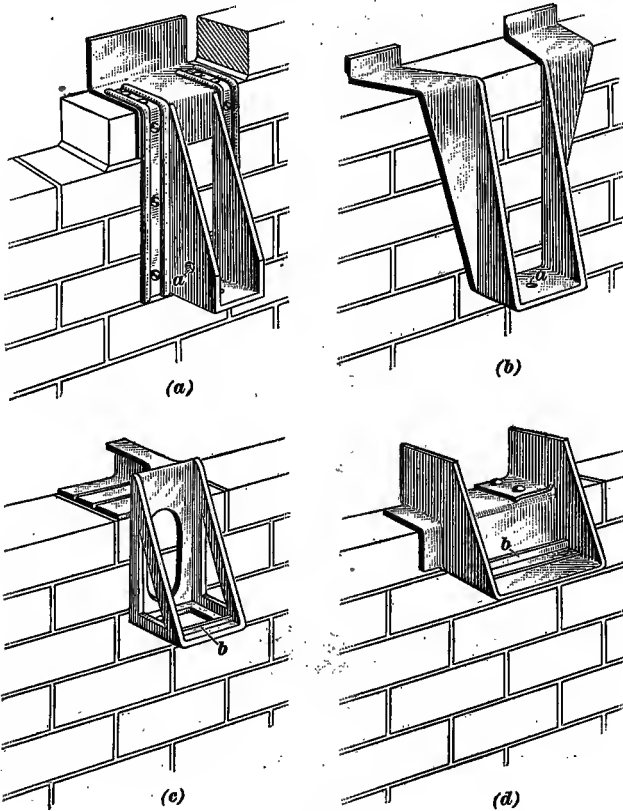
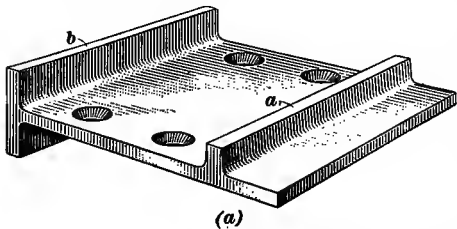

FIG. 40

time hold firmly to the joist. Fig. 40 illustrates four styles of hangers used to support joists and beams against brick walls. In none of these styles does the joist enter the wall, but rests in the socket; the top of the hanger being built into the wall:

In the hangers shown in (a) and (b), the joist is held in place by one or two spikes or lagscrews driven in through the hole *a* of the hanger and into the wood. In the hangers shown in (c) and (d), there is a ridge, or lug, *b* on the hanger. A notch is cut across the bottom of the joist and the ridge of metal fits into this notch.



(a)

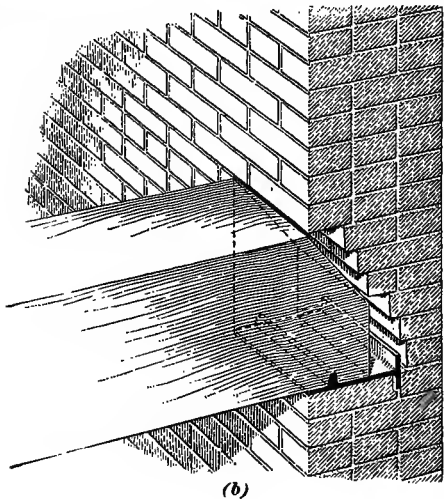

(b)

FIG. 41

The hanger shown in (a) is known as a **Van Dorn** hanger; the one in (b) is a **Lane** hanger; and those in (c) and (d) are **Duplex** hangers. These hangers also act as anchors, as the end of the beam is held from moving horizontally either by spikes or by the lugs of the hangers. At the same time if the middle of the joist should fail and drop by overloading or by fire, the end of the joist would easily fall from the hangers shown without injuring the wall.

**96.** In Fig. 41 is shown a wall plate that is used for wooden beams or girders that extend into the wall. In (a) is shown the bearing plate with the lug at *a* and the flange *b* which turns up and down into the wall. The beam is usually finished with



a bevel cut on the end, known as a **fire-cut**. This cut allows the beam to fall out of the wall without injury to the wall. The fire-cut is illustrated in (b).

**97.** In Fig. 42 are shown the four forms of iron anchors that are used for fastening beams in brick walls. The one

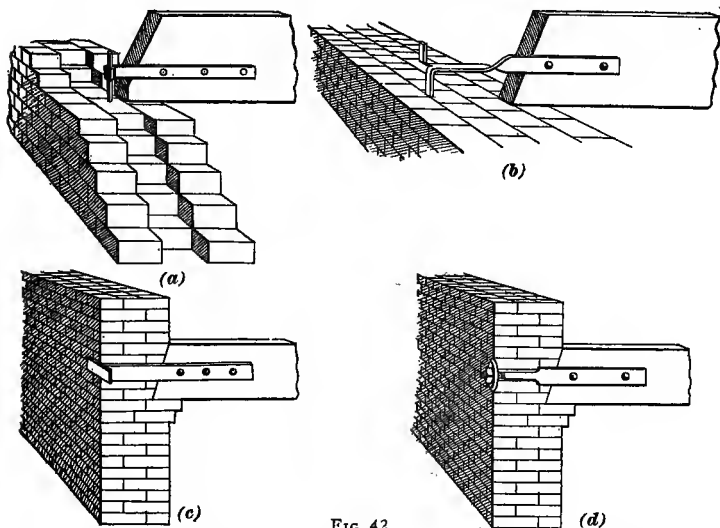

FIG. 42

shown in (a) is made of  $\frac{1}{4}'' \times 1\frac{3}{4}''$  iron, about 2 feet long; the end built in the wall is made of a  $9'' \times \frac{5}{8}''$  rod with the end of the anchor bent around it.

The anchor in (b) is made of  $2'' \times \frac{3}{16}''$  iron, 2 feet long; the end that goes in the wall is cut as shown, and about 4 inches is

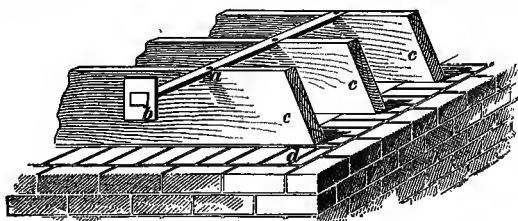

FIG. 43

turned at right angles to the anchor; the other end is twisted so that it can be nailed to the side of the joists.

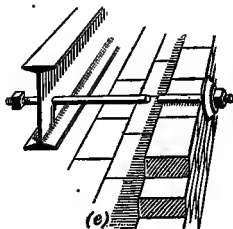
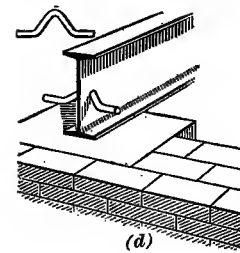
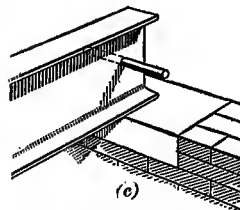
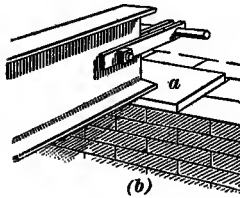
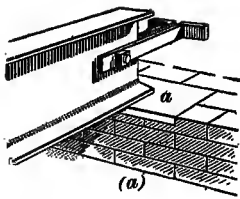

FIG. 44

An anchor that runs entirely through a wall is stronger than one that is simply embedded in a wall. On the other hand, the end of an anchor on the outside of a building makes an unsightly appearance. In warehouses and in back walls of buildings, however, when neat appearance is a secondary consideration, an anchor like that shown in (c) is used. It is made of  $1\frac{3}{4}'' \times \frac{1}{4}''$  iron, 2 feet 6 inches long, and has a plate of  $2'' \times 4'' \times \frac{1}{4}''$  iron forged on the outer end. This style of anchor may also be used in the middle of a wall in the same manner as those shown in (a) and (b).

In (d) is shown probably the strongest form of anchor. This style of anchor is made by flattening out a  $\frac{3}{4}$ -inch bolt so as to make a  $2'' \times \frac{1}{4}''$  portion to spike to the joist, and it is provided with a 5-inch cast-iron washer. A nut is placed on the outer side of the washer so that the anchor may be tightened up if necessary after the walls are built.

Anchors should always be spiked to the side of the joist or girder at or below the middle, as shown in the figure.

Fig. 43 shows the method of anchoring joists to walls where the joists and the walls run parallel. The anchor, let into the floor joists as shown at *a*, is provided with a washer *b*, and should be long enough to run over two or three joists, and 8 inches into the wall in order to give proper stiffness. The floor joists are shown at *c*, and the 12-inch brick wall at *d*.

98. Fig. 44 illustrates common forms of ties for anchoring I beams, channels, etc. to brick walls. Ordinary wall anchors are shown in (a), (b), (c), and (d), while in (e) is represented a tie-rod anchor running through the wall, to be used when the beam is run parallel to the wall.

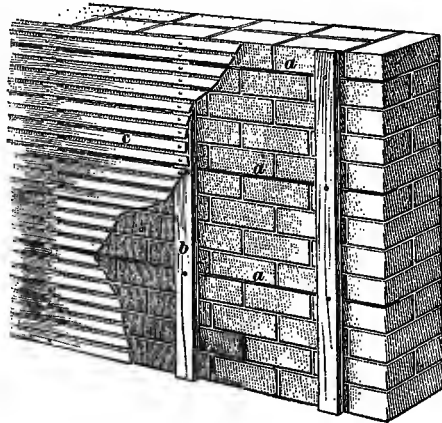

FIG. 45

Steel beams are generally supported on steel templets that are set in the wall. These templets, shown at *a* in (a) and (b), should be made large enough to distribute the load over a sufficient surface of brickwork so that the brickwork will not be crushed under the load.

99. Attaching Furring, Grounds, Etc. to Brick

Walls.—In most buildings it is necessary to attach wood or metal furrings, grounds, bucks, etc., to brickwork, and there are various methods used for this purpose.

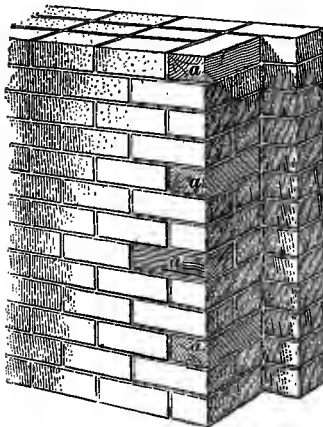

FIG. 46

Where the interior of the wall is to be furred with wood furring to receive lathing and plastering, common lath are laid between the bricks every few joints as shown at *a* in Fig. 45. They are held in place firmly by the brick and afford nailing for the furring. Wood should not be inserted in chimney walls and breasts, but metal furring and lath should be used, the furring being attached to wire loops.

Wood should not be inserted in chimney walls and breasts, but metal furring and lath should be used, the furring being attached to wire loops.

or other devices built in the brickwork. Nails should never be driven into a chimney wall less than 8 inches thick, as they are liable to break out the mortar on the inside and render the chimney defective.

**100.** In special places, such as at a door jamb, it is necessary to provide specially good nailing, and wood bricks are

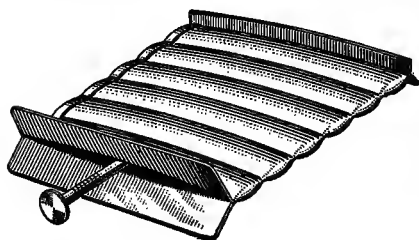

FIG. 47

built into the wall as shown at *a* in Fig. 46. These are blocks of wood of the same size as a brick and are built in the wall in the same manner as ordinary brick.

**101.** A patented device known as a wall plug

is shown in Fig. 47. This consists of a bent corrugated piece of metal that is built into the joints of the brickwork and into which a nail can be driven securely.

**102.** Devices for attaching work to brick walls, but which are not built in the walls, will be discussed elsewhere, as they do not properly come under the subject of brickwork.

---

## CHIMNEYS AND FIREPLACES

---

### CHIMNEYS

**103. Design.**—The correct location, area, and height of chimneys should be carefully considered in designing a building. To make a chimney draw well, a separate flue should be provided extending from each fireplace, stove, or furnace to the top of the chimney. It is not considered good practice to use one flue for two or more of these features, although it is sometimes done with satisfactory results.

**104. Construction of Chimneys.**—Chimneys are generally constructed of brick and contain fireplaces, spaces for



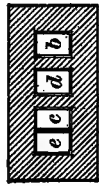
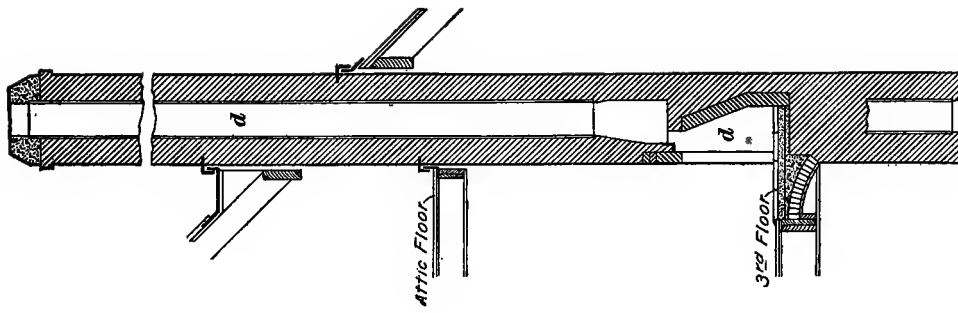

Section E.E.

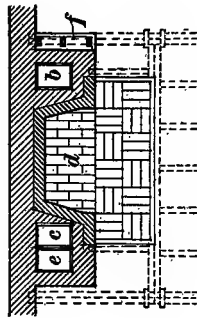

Section D.D.

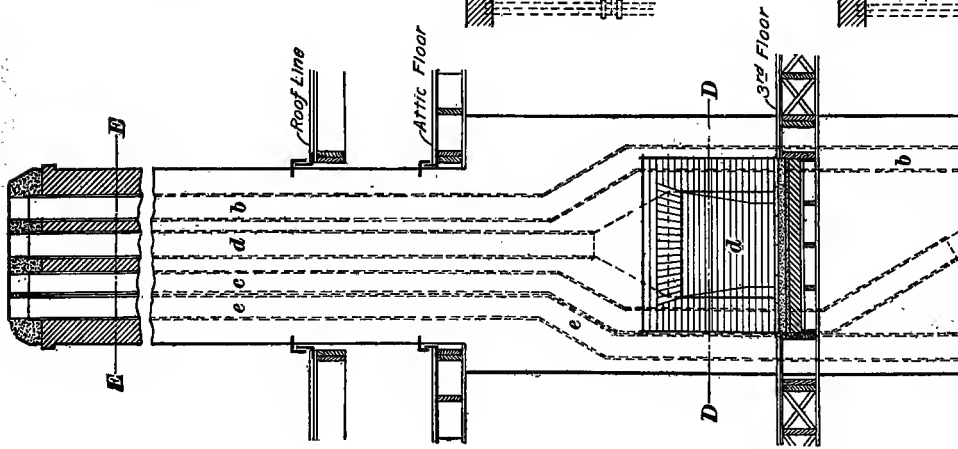
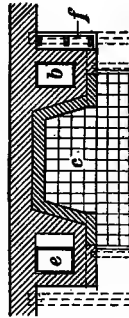

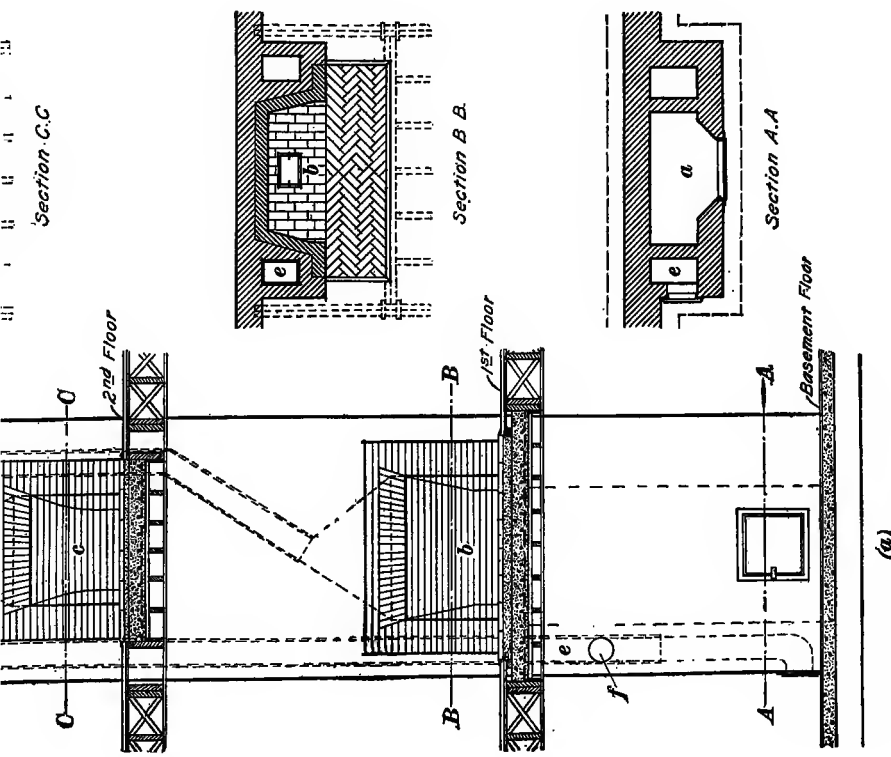
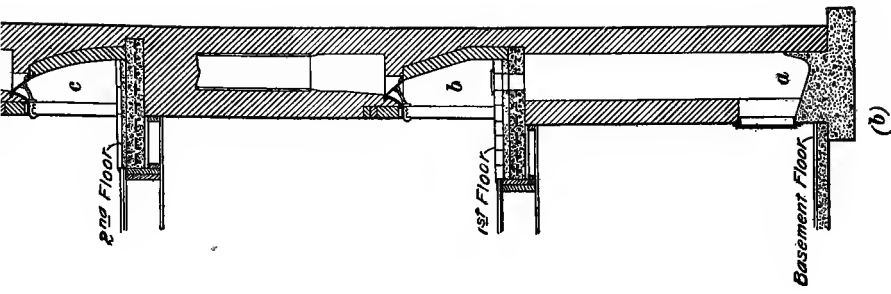

FIG. 48





ranges, ash-pits, flues, etc. These features are combined so as to form a compact and economical structure which is sometimes very complicated.

An example of the arrangement of parts in a chimney is shown in Fig. 48, which is a chimney built in with the side wall of a brick building. In (*a*) is shown a front elevation of the chimney; in (*b*), a section through the center lines of the fireplaces. Between these views are shown horizontal sections or plans of the chimney at each floor, in the cellar, and above the roof.

In the upper stories are shown the fireplaces *b*, *c*, and *d* and in the basement or cellar the ash-pit *a*. This ash-pit receives the ashes from the fireplace *b* through the ash door shown in the section (*b*). The ash-pit is provided with a cast-iron door through which the ashes are removed. A flue *e*, shown in dotted lines in (*a*), reaches from the basement floor to the top of the chimney. At the bottom of this flue, near the floor on the side of the chimney, is shown an iron door for cleaning out this flue. At *f* is an opening into the flue *e* designed to receive a smoke pipe from a heater or furnace. The flue *e* runs up past the fireplaces *b*, *c*, and *d* and is then bent toward the center of the chimney.

**105. Flues.**—The flues from the fireplaces are similarly shown by dotted lines extending from points above the tops of the fireplaces to the top of the chimney. The brick partitions between chimney flues are called **withes**. As shown, the flue from any fireplace must pass on the side of the fireplace above, but the flues are deflected above the last fireplace and brought together so as to make the chimney, where it extends above the roof, as compact as possible.

The bends in the flues should be as gradual as possible so as not to check the flow of smoke and gases up the flue. The double dotted lines indicate that the flues are lined with terracotta linings. These flue linings should be carefully cut to miter or fit together at the bends so as to form a smooth channel. Flues having slight bends are considered preferable to perfectly straight flues, as the bends prevent rain and sleet from

falling into the fireplace, and also tend to check the downward passage of currents of cold air. The smoke flues are sometimes formed in brickwork without linings, in which case the walls of the chimney should be 8 inches in thickness. The interiors of such flues should never be plastered, as the plastering is disintegrated by the heat and will fall off. When flue linings are used the chimney walls need be only 4 inches in thickness. Where linings are not used a 4-inch brick partition, or withe, should be built between the flues. The building codes of many cities require that all chimney flues be lined with fireproof material such as terra-cotta flue linings.

**106.** The advantages of using terra-cotta flue linings are several. In the first place, they are made in 24-inch lengths, which makes few joints. The inside surfaces of the linings are smooth and thus facilitate the flow of smoke and gases up the chimney. In unlined brick flues there is always a risk that the joints between the bricks may not be properly filled with mortar and that sparks will find their way through the crevices and start a fire in adjacent wooden parts of the building. When the flues are lined, however, this danger is reduced to a minimum.

**107. Sizes of Flues.**—The sizes of brick flues are generally made in accordance with the sizes of bricks used on the work. These flues are about 4, 8, 12, 16, and 20 inches in either direction. Terra-cotta flue linings are made in circular, square, or rectangular shapes. The square and rectangular flue linings are made to fit in with the brickwork.

**108.** In Table II is given a list of the customary sizes of terra-cotta flue linings. The dimensions of the square and rectangular flues are the outside dimensions. The thickness of the shell, which is from  $\frac{3}{4}$  inch to 1 inch, is deducted in estimating the net area of the flue. The inside diameters of the circular pipes are given and the areas are easily calculated from them. While  $4\frac{1}{2}$ -inch flue linings are listed in Table II, this dimension in a smoke flue is too small to be effective and should not be used except where unavoidable or in fireplaces where only gas is burned, which permits of the use of a small flue.

**109. Proportions of Flues to Fireplaces.**—A good proportion for flues for fireplaces in which wood or bituminous coal is to be burned is to make the sectional area of the flue equal to one-tenth of the area of the fireplace opening if the flue is rectangular, and one-twelfth, if the flue is circular. Thus, for a fireplace that is 30 inches wide by 30 inches high and whose area is 900 square inches, the flue area for the rectangular form of flue would be 90 square inches, which will

TABLE II

DIMENSIONS AND EFFECTIVE AREAS OF FLUE LININGS

Rectangular Flues		Circular Flues	
Outside Size Inches	Approximate Inside Area Square Inches	Inside Diameter Inches	Inside Area Square Inches
$4\frac{1}{2} \times 8\frac{1}{2}$	16.25	6	28.27
$4\frac{1}{2} \times 13$	27.50	7	38.48
$4\frac{1}{2} \times 18$	40.00	8	50.27
$8\frac{1}{2} \times 8\frac{1}{2}$	42.25	9	63.62
$8\frac{1}{2} \times 13$	71.50	10	78.54
$8\frac{1}{2} \times 18$	104.00	12	113.10
13 × 13	121.00	15	176.72
13 × 18	176.00	18	254.47
18 × 18	256.00	20	314.16
		24	452.39

require an 8"×12" brick flue. If flue linings are used, an 8½"×18" or a 13"×13" flue will be required. The area of a circular flue lining would be  $\frac{1}{12} \times 900 = 75$  square inches. The nearest stock size of lining is 10 inches in diameter, which, having an area of 78.54 square inches, would be satisfactory.

If anthracite coal is to be burned, the flue area may be made one-fifteenth of the area of the fireplace opening for a rectangular flue, and one-eighteenth for the circular form. Thus, for a fireplace with an area of 900 square inches a rectangular

flue with an area of  $\frac{1}{15} \times 900 = 60$  square inches will be required. According to Table II, an  $8\frac{1}{2}'' \times 13''$  flue must be used for this area. A round flue of  $\frac{1}{18} \times 900 = 50$  square inches, or 8 inches in diameter, will be needed.

**110. Chimney Caps.**—The portion of the chimney projecting above the roof should be laid up in strong cement mortar so as to prevent its disintegration, and should be covered with a protecting cap of stone or concrete. This cap may be pierced with holes to match the flues as shown in (a) in Fig. 49,

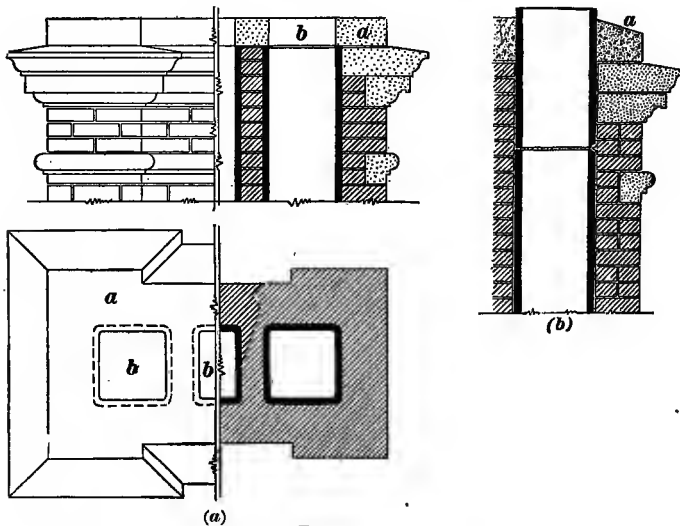

FIG. 49

in which *a* is the capstone of the chimney and *b* the holes cut through flush with the inner edge of the flue lining and covering the joints between the brickwork and the linings. This prevents water from entering the joints of the brickwork, which would soon cause disintegration of the mortar, loosening of the bricks, and discoloration on the exterior of the chimney.

Another method frequently followed is to project the flue lining above the masonry, as in (b), and to build on a concrete or cement cap, *a*. This prevents swirling air-currents, with perhaps accompanying snow flakes, from descending the flue.

It also tends to decrease the erosion under the cap due to water entering the exposed joints in the brickwork. Concrete, however, is more apt to deteriorate under heat, cold and moisture than stone, and thus is likely to prove less durable.

A chimney cap that is not perforated is shown at *a* in Fig. 50. This cap is supported at the four corners by small brick piers between which the smoke passes through the spaces *b*. Such a cap prevents rain and sleet from falling into the chimney.

**111. Chimney Pots.**—Instead of flat caps, chimney pots made of terra cotta are sometimes used. These pots form

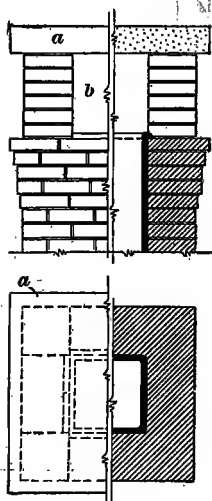

FIG. 50

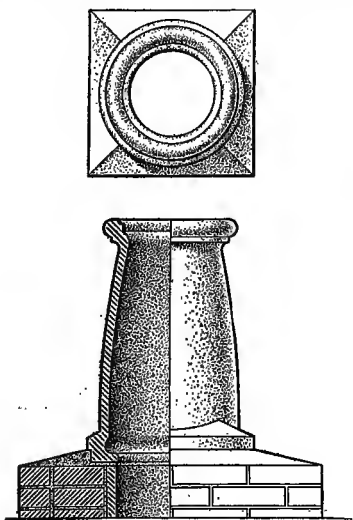

FIG. 51

a picturesque and ornamental finish to a chimney. They are made in many different forms, which are kept in stock by dealers. Examples of terra-cotta chimney pots are given in Figs. 51, 52, and 53 showing half exterior views and sections. The sections show the manner in which the pots are set, so as to cover the flue lining in the chimney. One pot is required for each flue. A strong cement mortar is used in setting the pots and is graded away from the pots to the outside of the chimney so as to form a wash. The design in Fig. 51 is a simple one

with graceful lines and is round or circular in plan. The design in Fig. 52 is more elaborate and is octagonal in plan.

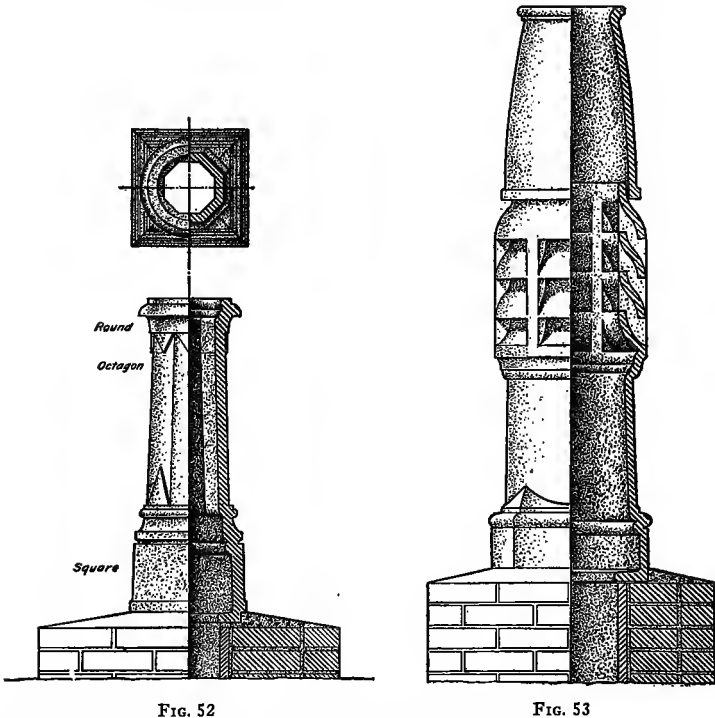

FIG. 52

FIG. 53

Fig. 53 is a larger and more elaborate design than the others, with outlets for the smoke in the sides as well as the top.

#### FIREPLACES

**112. Construction of Fireplaces.**—The general construction of a fireplace is shown in Fig. 54. The projection of the chimney into the room to enclose the fireplace is called the *chimney breast*. The height of an ordinary fireplace opening should be about 2 feet 6 inches or 2 feet 8 inches above the finished floor, its depth from 16 inches to 24 inches, and its width from 2 feet to 5 feet. If the height of the opening is

made more than 2 feet 8 inches the flue should be made of such a size that the upward draft will be strong enough to prevent smoke coming out into the room.

While a good fireplace can be made that is rectangular in plan, it is better to slope the sides and back as shown in the

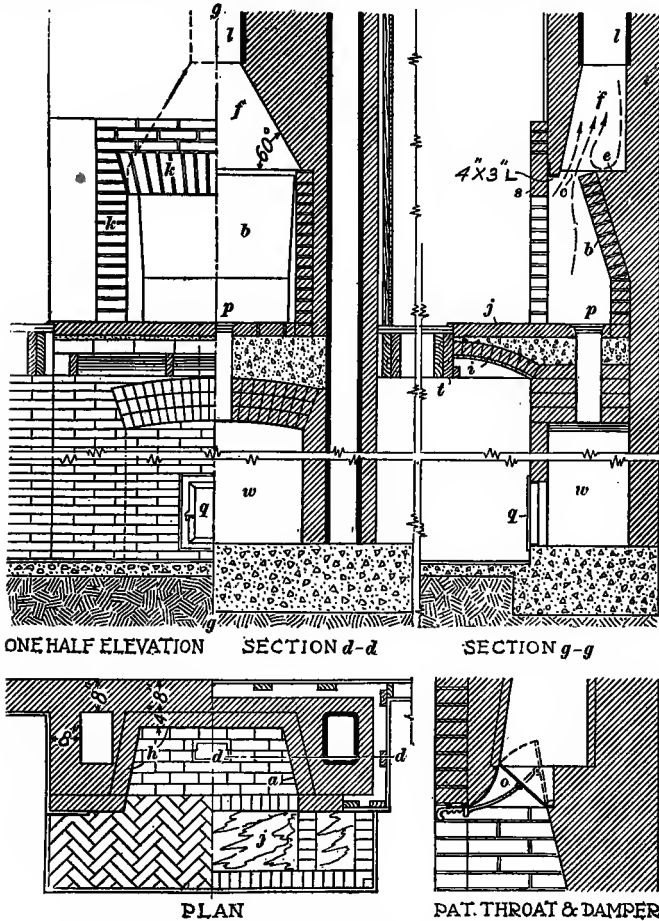

FIG. 54

figure, as these sloping surfaces throw the heat into the room. A slope of about 3 inches in 1 foot, as shown in the plan, is satisfactory.

The *back b* of the fireplace should slope forward and form the *throat c*, which should be from  $2\frac{1}{2}$  inches to 4 inches in depth and the full width of the fireplace opening. The total area of the throat should be not less than the area of the flue lining. The throat should be, at least, 2 inches or 3 inches above the top of the opening of the fireplace as shown at *s* and as near the front of the fireplace as possible. Backs may also be curved, as illustrated in fireplace *c* in Fig. 48.

A *smoke shelf e*, Fig. 54, is an important feature. It prevents the air from rushing down the flue when a fire is started and forcing smoke into the room. The *smoke chamber f* is formed by drawing the brickwork together at an angle of  $60^\circ$  on the sides until it is reduced to the dimensions of the flue lining. The bricks should be clipped so as to present as smooth a surface as possible and not a series of offsets. The lining *l* is then started, being supported by the brickwork, as shown. The hearth shown at *j* is extended in front of the fireplace so as to catch embers that may fall out of the fire. It is supported on a trimmer arch *i*, consisting of a single rowlock arch about 20 inches wide springing from the chimney to the header *t*. This arch is laid upon a wooden center which is sometimes left in place, but is liable to be set on fire by a very hot fire on the hearth above. A better practice is to remove the centering of the trimmer arch and cover the space with metal furring and metal lath, to which the plastering may be applied. Upon the trimmer arch, the hearth is built up of cement or concrete and is finished in tile, marble, or brick. The hearth should extend at least 12 inches on each side of the fireplace opening. In Fig. 48 is shown another design for a hearth in fireplaces *b* and *c*. This design is built of reinforced concrete which is cast partly upon wooden forms and partly upon the masonry of the chimney. Iron rods are placed as shown and the concrete is poured so as to surround them. This construction forms a solid slab upon which the finish of the hearth is placed. This finish may consist of brick, tile, or cement.

**113. Finish of Fireplaces.**—The fireplace shown in Fig. 54 is lined with firebrick or good hard-burned brick. A



loose grate in which coal may be burned is sometimes placed in a brick opening. In some cases ornamental sheet-iron or cast-iron linings are placed in the fireplace as shown in Fig. 55.

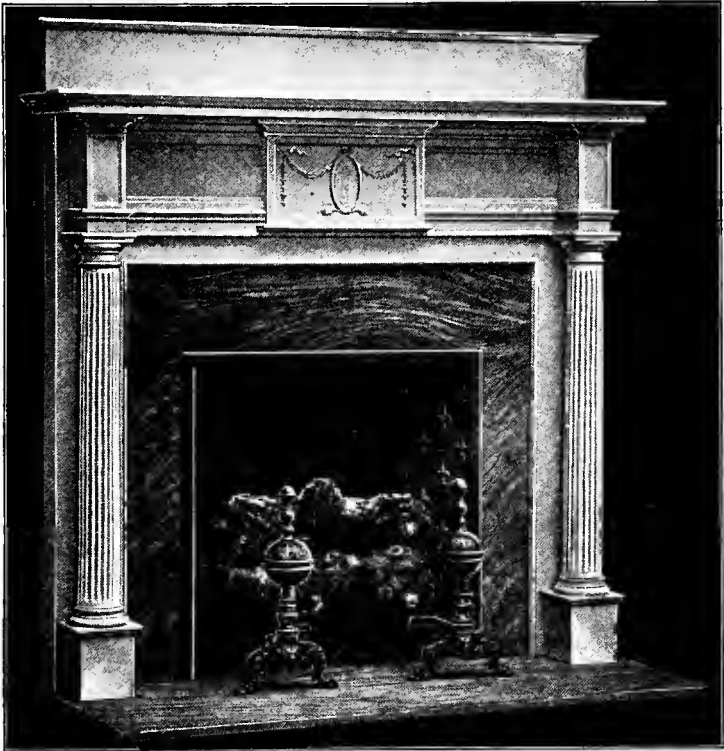

FIG. 55

In this case a hard-burned common brick or else firebrick may be used in constructing the fireplace, as the lining will cover this work.

**114. Patent Throats and Dampers.**—As it is desirable at times to reduce the draft in a fireplace, a damper should be provided that will permit of partially or entirely closing the throat of the fireplace. There are several patent dampers on the market that are designed to be built in at the top of the

fireplace for this purpose. An example of such a damper is shown in Fig. 54, which shows by solid lines the position of the damper when closed and the position when open by dotted lines. Above this damper a patent throat is sometimes used and is made of concrete or of terra cotta similar to the flue linings. This throat forms the sloping smoke chamber that would otherwise be made in brickwork.

**115. Ash Doors and Pits.**—When possible, it is very desirable to have an ash door in the hearth under a grate through which ashes may be dropped into a suitable space in the cellar portion of the chimney. This arrangement is shown in Fig. 54, where the ash door is at *p* and the pit at *w*. A door *q* is provided at the bottom of the ash-pit through which the ashes may be removed from time to time. A similar arrangement is illustrated in Fig. 48.

# FACE AND ORNAMENTAL BRICKWORK

---

## INTRODUCTION

**1. Use of Brick.**—Brick is one of the most useful of all building materials as well as one with which highly artistic effects can be obtained. Its use for utilitarian purposes, such as building walls and piers, will be considered in the Section entitled *Common Brickwork*. Its possibilities as a decorative material will be discussed in the following pages.

**2. Brick as a Decorative Material.**—Brick can be used ornamentally or decoratively in two different ways. One way is by laying it so as to form patterns on the surface of walls and piers by the use of different sizes, colors, and surface textures, also by using mortar of varying color and texture and by using mortar joints of different thicknesses. This method of producing attractive and artistic effects in brickwork will be discussed under the heading of Face Brickwork. An example of artistic face brickwork is shown in Fig. 1.

**3.** Brick can also be used as relief ornament in the form of string-courses, cornices, brackets, etc., which project beyond the face of the wall, as shown in Figs. 2, 6, and 7. Brickwork of this description will be referred to as Ornamental Brickwork.

**4. Combinations of Face and Ornamental Brickwork.**—Combinations of these methods of using brick have been employed with charming results, as shown in Fig. 2. This



FIG. 1

building is a dove-cote, or pigeon coop, at the Manoir D'Angot in France and was built in the 16th century. This example illustrates the use of *ornamental brickwork* in the projecting

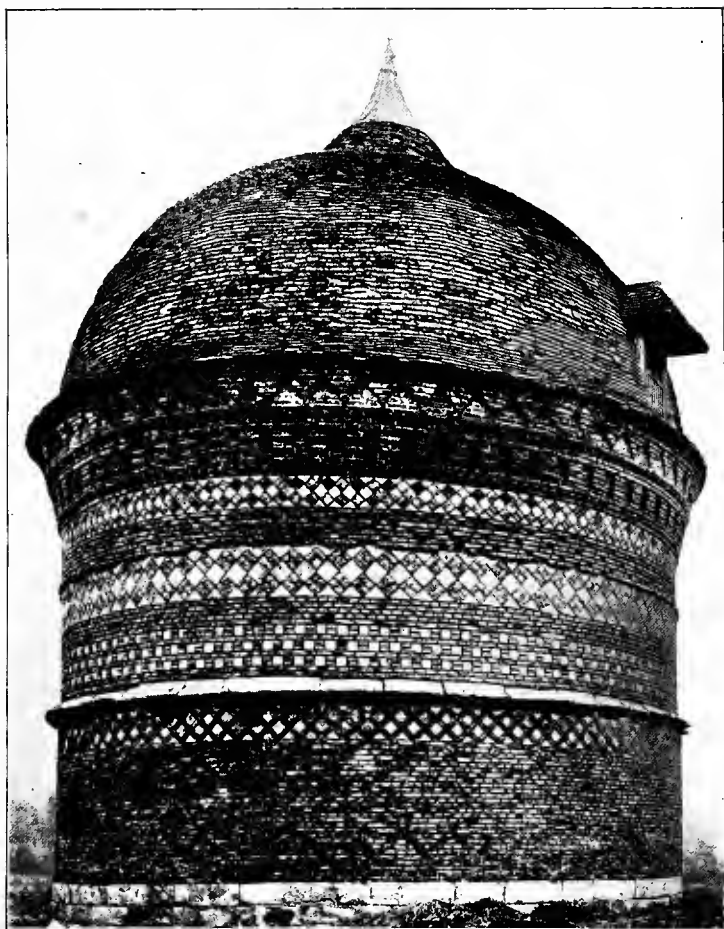

FIG. 2

cornice as well as of *face brickwork* in the patterned surface of the wall. In this building, small blocks of stone have been used in connection with brick to produce contrast in texture and color in the patterns.

5. At the present day architects and builders have at their disposal a wealth of material in the form of bricks of different sizes, shapes, colors, and textures, as well as tiles of all colors, which afford excellent opportunities for designing walls of artistic excellence. An example of such a wall is given in Fig. 1.

### DEFINITIONS

6. As there are a number of terms used in connection with brickwork that will be used frequently in connection with the following descriptions, definitions of these terms are here given.

In referring to the individual bricks, the different faces of the brick will be referred to as follows and as illustrated in Fig. 3.

The **top** is the upper large surface.

The **bottom** is the lower large surface.

The **face** is the long narrow side or edge that shows in the face of the wall.

The **back** is the long narrow side or edge opposite the face.

The **heads** are the small ends of the brick.

A **unit** is one brick or piece of brick used in a pattern or a bond.

A **stretcher** is a brick that is laid on its bottom with its face showing in the face of the wall, or a brick whose length extends in the direction of the wall, as shown in Fig. 4 at *a*.

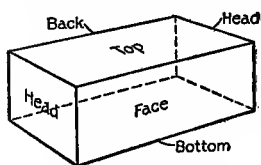

FIG. 3

A **header** is a brick laid on its bottom with the head showing in the face of the wall, as at *b*.

A **bull header** is a brick laid on its face or back and showing a head in the face of the wall, as at *c*.

A **course** of brick is one horizontal row of bricks, as at *e*.

A **stretcher course** is one row of *stretchers*, as at *d*.

A **header course** is one row of *headers*, as at *e*.

A **rowlock**, or **rollock**, **course**, is a row of *rowlocks*, or *bull headers*, as shown at *f*.

A **soldier course** is a row of bricks with the faces laid vertically, as shown at *g*.

A **string-course** is a horizontal course continued across the face of a building. It generally projects and may be flat, molded, or carved.

A **herring-bone pattern**, shown at *h*, consists of bricks laid diagonally in opposite directions.

**Bond** is the arrangement of the bricks in the wall by which the wall is tied, or bonded, together. This bonding is accomplished by lapping each brick over two or more bricks below it.

**Face bond** is a bond, or pattern, which shows on the face of the wall but is not generally carried through the entire thick-

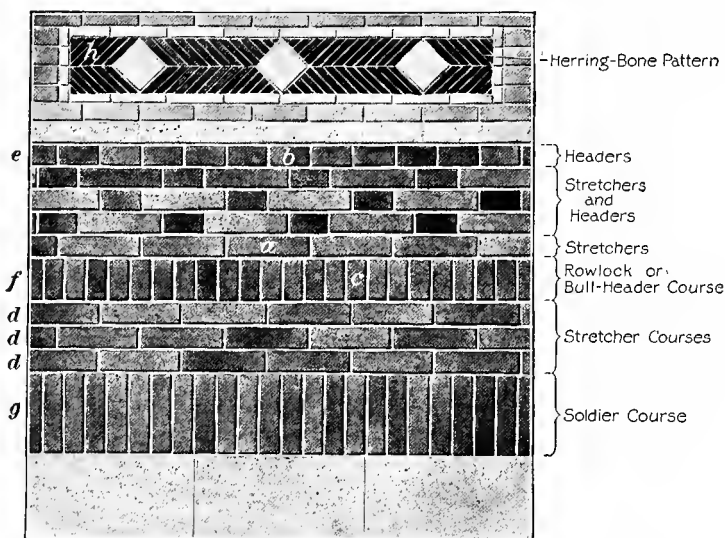

FIG. 4

ness of the wall. The substantial body of the wall may be built in some strong bond that is economical to build, while the face of the wall may be finished in a more elaborate and totally different bond. This ornamental facing of brick must be securely fastened to the wall back of it, upon which it depends for support. The substantial wall to which the facing is attached, or bonded, is often referred to as the **backing**.

The **brick field** is the brick surface of the wall.

**Breaking joints** is the arrangement of the joints of the brickwork so that the vertical joints in one course shall not come directly above the vertical joints in the course below.

A **blind joint** is a joint between two bricks that is made as thin and inconspicuous as possible so as scarcely to be noticeable.

### BRIEF HISTORY OF BRICKWORK

7. Brick architecture has naturally developed in countries or parts of countries where there was an abundance of clay from which bricks could be made, and where there was a scarcity of wood and stone. Thus, in ancient Babylonia, most of the building of importance was done with clay products such as brick. Some of these bricks were merely dried in the sun,

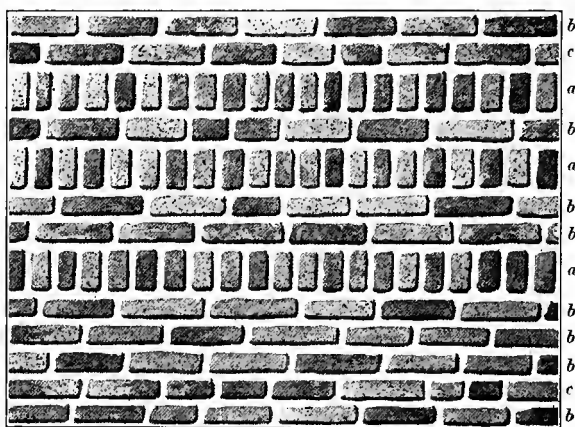

FIG. 5

and are known as *sun-dried* bricks, while some of them were baked in kilns as is done at the present day. A few examples of typical brickwork of various countries, both ancient and modern, will now be described and shown.

8. **Egypt.**—Brickwork found in ancient Egyptian tombs is illustrated in Fig. 5, which shows an example from the tomb



of Mersekha, built about the year 2900 B. C. This brickwork shows a pattern, or bond, which consists of rows of headers *a* separated by rows of stretchers *b*. The headers are bull

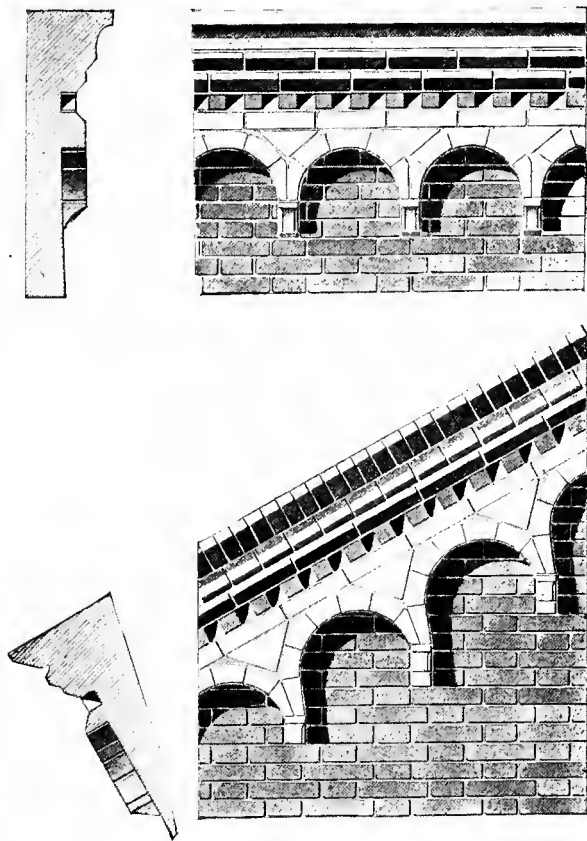

FIG. 6

headers. The bricks are roughly molded and irregular in size. Headers are introduced occasionally in the rows of stretchers, as shown at *c*. A number of the well-known Egyptian pyramids were built of brick.

**9. Ancient Rome.**—The Romans used brick extensively. The bricks themselves were always flat, varying from  $\frac{1}{2}$  inch

to 2 inches in thickness. In the Baths of Titus, erected about 80 A. D., the bricks were about 18 inches by 6 inches by 2 inches in size. Bricks found in remains of Roman structures in England are dark red and light red in color, these colors being used together in the walls. These bricks were laid with wide mortar

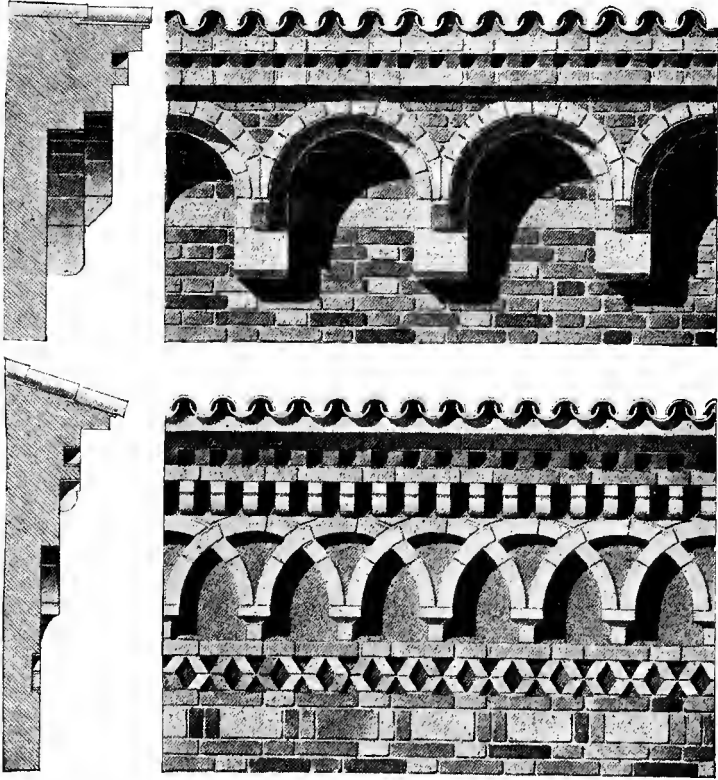

FIG. 7

joints, and the mortar used was generally composed of lime mixed with broken tiles, sand, and gravel more or less coarse in size.

Excellent examples of Roman brickwork have been found in England. At Caster, an ancient Roman camp, a fine example of herring-bone masonry was found. Another example exists in St. Botolph's Priory near Colchester.

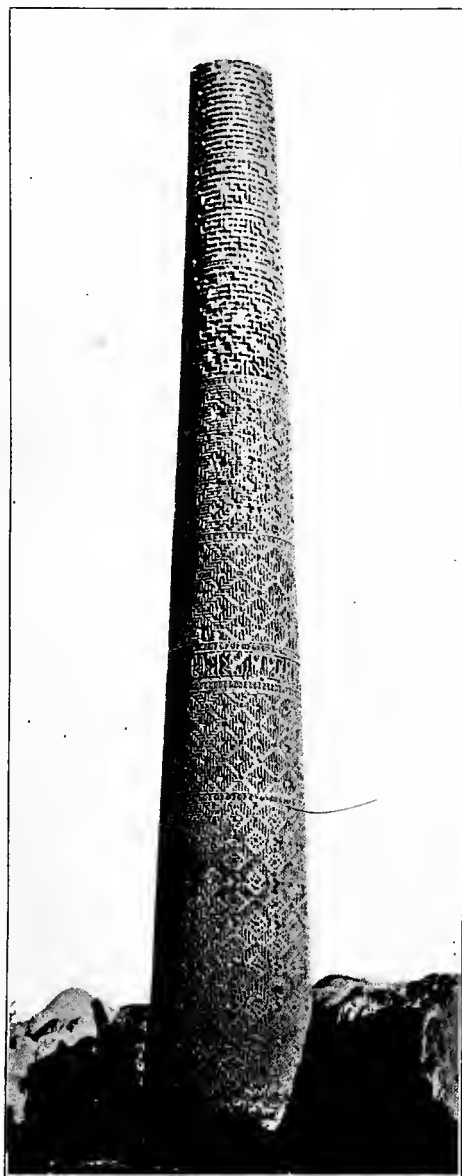

FIG. 8

**10. Italy.** — In Italy during the Middle Ages, especially in the cities of the North, brick architecture reached great perfection in its application to churches and civic buildings. Brick was used in connection with terra cotta and stone, and ornamental brickwork of the highest artistic character was used in the cornices of Italian buildings. Examples of these cornices are shown in Figs. 6 and 7. Other examples of Italian brickwork are: Baptistry of St. Stefano, 4th century; St. Agata in Ravenna, 5th century; Cathedral, Cremona, 12th century; Broletto (Town Hall), Brescia, 13th century; San Pietro Ciel D'Oro, Pavia, 13th–15th centuries.

**11. Persia.** — It was in the 16th century that Persian brickwork reached that degree of excel-

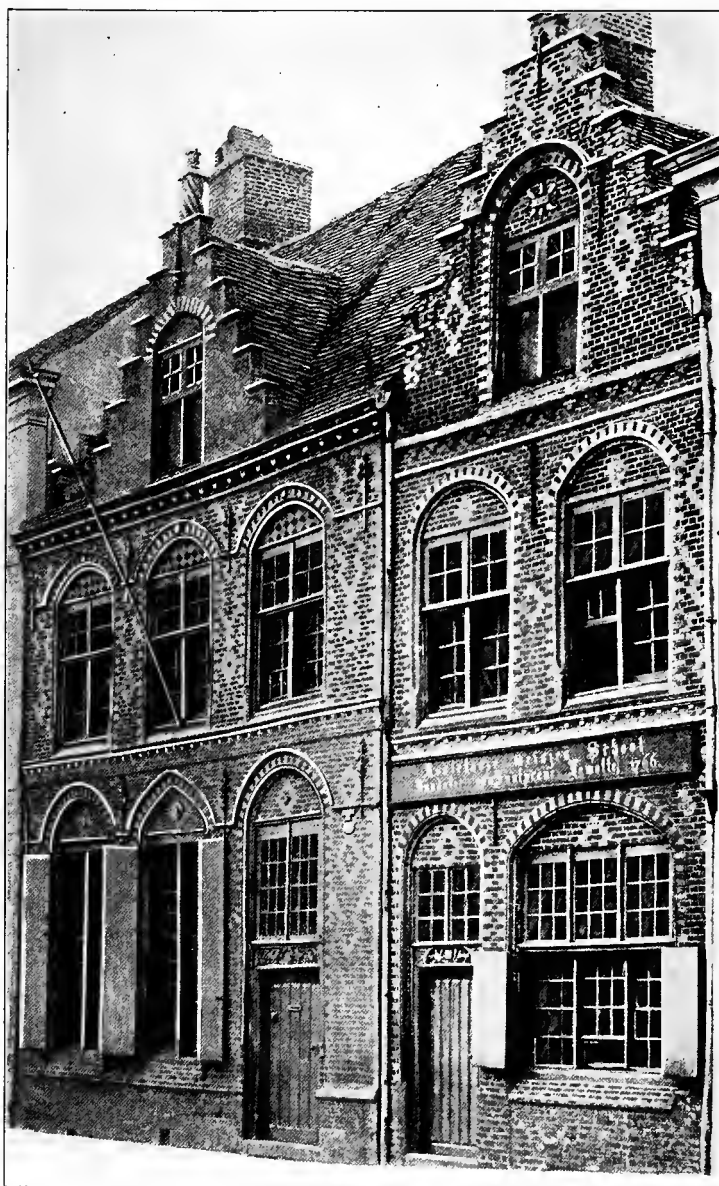

FIG. 9

lency which characterizes so many Persian mosques and mausoleums as masterpieces of the brickbuilder's art and ingenuity. Notwithstanding that brick architecture had been practiced in Persia from the 7th century, it was in the early part of the 16th century that buildings were built that are notable for their workmanship, color, and design. At Bostam, Ispahan, Tebriz, and Ardebil, the mosques and minarets are monuments of the possibilities of brick as a means of decoration. An example of this work is given in Fig. 8. The building shown is a minaret, or prayer tower, connected with the mosque of Tschihil Sutun in Damgan, Persia, and was built in the 16th century.

**12. Netherlands.**—During the 14th and 15th centuries, the brickbuilders of the Netherlands were not only erecting their homes and public buildings of brick, but were also instructing their neighbors, the English, in the use of brickwork. Their buildings with the quaint *stepped* gables possess great individuality and charm. In Fig. 9 are shown two excellent buildings which were built in Ypres, Belgium. These buildings show the delicacy and refinement with which brick was employed, and also illustrate the formation of patterns by the use of brick of different colors. Molded brick have also been used around the windows and in the string-courses.

Notable examples of brickwork are given in the following list of buildings:

- Church of St. Martins, Ypres, Belgium. . . . 14th century
- City Gates, Haarlem, Holland. . . . . 15th century
- Tournal House, Holland. . . . . 15th century
- St. Jean Hospital, Hoorn, Holland. . . . . 16th century
- Convent des Celestines, Tournal, Holland. . 16th century

**13. England.**—The earliest brick building existing in England is Little Wenham Hall in Lincolnshire, which was built in 1260. By the year 1300, brickwork was in general use in England. The great manor houses of England were erected in the 15th and 16th centuries, as shown by the following list of such buildings:

	ERECTED
Hurstmanceaux Castle .....	1440
Tattershall Castle .....	1440
Rye House (Hertfordshire).....	1440
Lollard's Tower (Lambeth Palace).....	1454
Layer Marney Towers .....	1500
Sutton Place, Guilford.....	1523
Compton Wynyates .....	16th century
East Barsham Manor .....	late 16th century

A portion of the last-mentioned building is shown in Fig. 10.

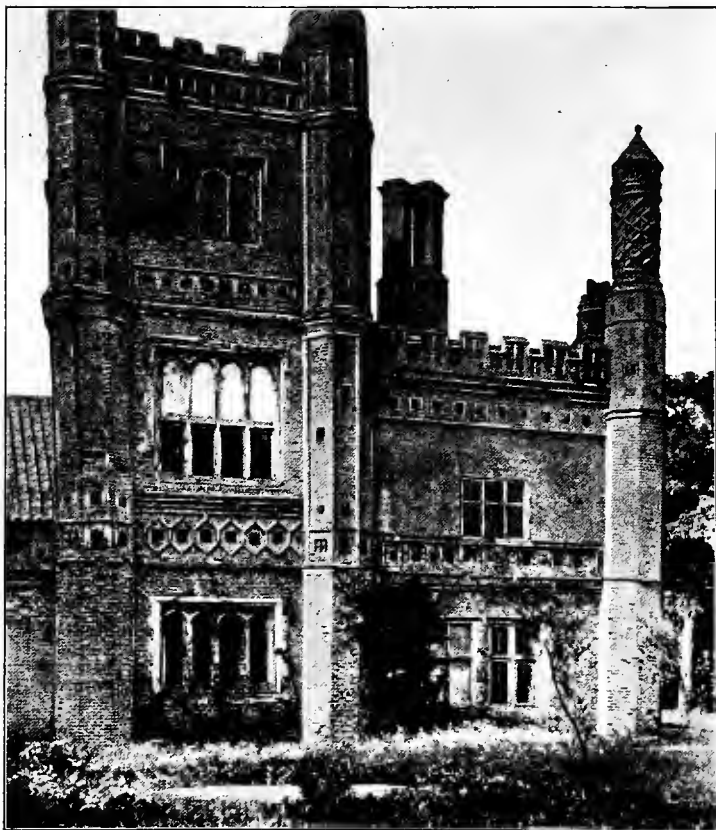

FIG. 10

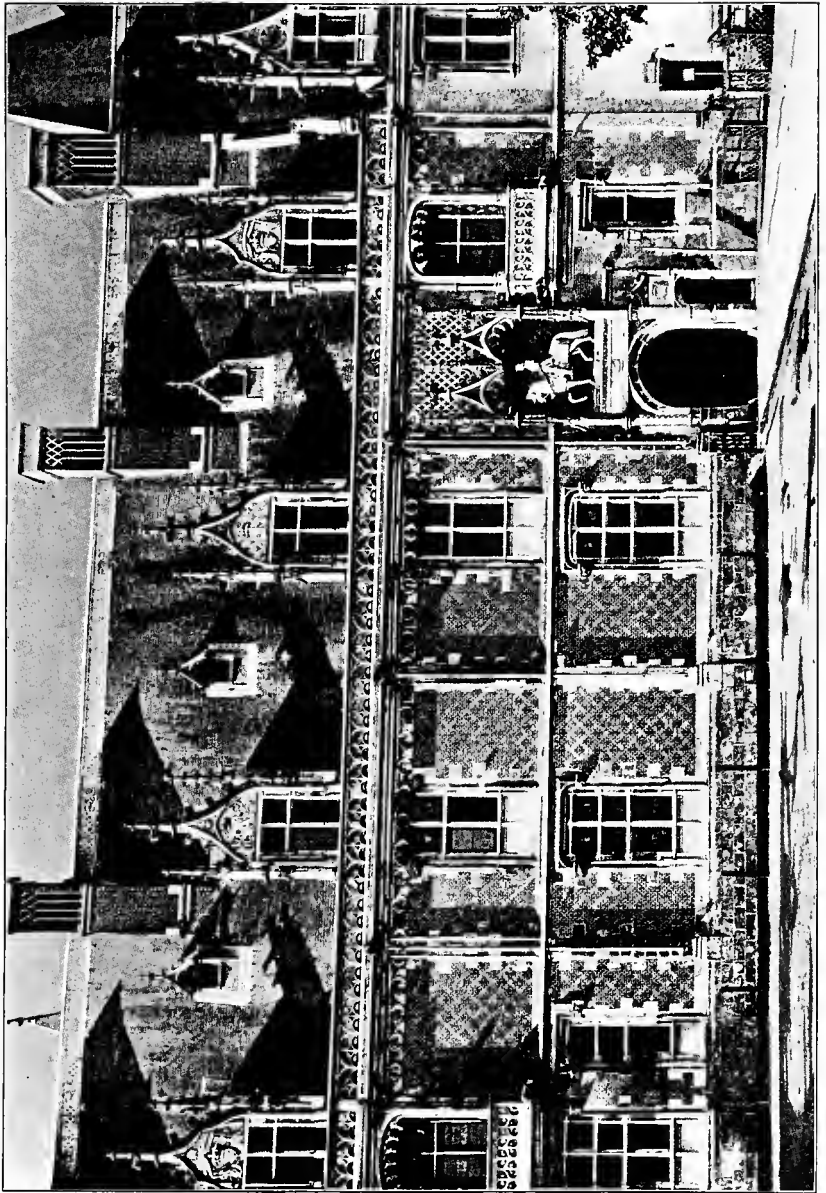

FIG. 11

It was undoubtedly from the Flemish brickbuilders of the Netherlands that the English received the incentive to erect the series of magnificent brick buildings that mark the progress of the history of England.

**14. France.**—The French people used brick with excellent taste but generally used it for wall treatments in which the brickwork was framed by stone. This treatment is shown in the Louis XIII wing of the Château of Blois illustrated in Fig. 11. The brick surface has a crisscross pattern formed by bricks that are lighter in color than the others. A particularly charming example of French brickwork is shown in Fig. 2, which is the dove-cote at the Manoir D'Angot of the 16th century. Other noteworthy examples of brick architecture are the Château de Martainville of the 15th century at Epreville; the Manoir D'Angot itself, and a pigeon house at Boos.

**15. America.**—In America, during the Colonial period of its history, our architects and builders developed the Colonial Style of Architecture, which was an offshoot of the Georgian style in England. Brick was imported from England and used with considerable taste in some of the colonial houses in the southern colonies, such as Maryland and Virginia. A decline in architectural taste occurred during a great part of the 19th century but a revival, or renaissance, of good taste has been experienced in recent years which gives promise of most satisfactory results.

Many excellent buildings by such architects as H. H. Richardson, McKim, Mead, and White, and by prominent living architects, are fine examples of brickwork. Designers of the present day have the best possible opportunities for producing fine brickwork, as the manufacturers are now making superior grades of brick which offer great varieties of color, size, and texture as well as durability.



## FACE BRICKWORK

---

### DESCRIPTION OF FACE BRICK

---

#### BRICK SHAPES AND SIZES

**16.** \*The sizes of brick units varied in past ages, according to the locality in which they were produced and the use to which they were to be put, just as they do today. In an ancient Sargonic arch, made about the year 4000 B. C., the bricks measure 12 inches by  $2\frac{1}{2}$  inches by 6 inches. Ancient Babylonian brick measured 12 inches by  $5\frac{7}{8}$  inches by  $2\frac{1}{4}$  inches. Other Babylonian bricks measured  $8\frac{3}{8}$  inches by 2 inches by  $4\frac{7}{8}$  inches, which are similar in size to bricks made at the present time.

The Roman bricks, as has been stated, were made 18 inches by 6 inches by 2 inches in size.

**17. Brick Sizes as Used in the United States.**—The standard sizes of brick in the United States are those adopted by the National Brickmakers' Association. For common brick the standard size is  $8\frac{1}{4}$  in.  $\times$  4 in.  $\times$   $2\frac{1}{4}$  in.; for face brick,  $8\frac{3}{8}$  in.  $\times$   $4\frac{1}{8}$  in.  $\times$   $2\frac{1}{4}$  in.

The brick manufacturers, in making standard brick, only approximate these sizes, as it is impossible to regulate absolutely the amount of shrinkage that will take place between the time the brick is molded and the time it is thoroughly burned. Differences in size are almost invariably found in the same shipment of brick.

It is customary, especially when a fine joint is to be used, to sort out these face brick and place all the bricks of the same size in one pile and those of other sizes in other piles. These different sizes are used in different portions of the wall so that the difference in size is not noticeable.

In some cases the manufacturers make bricks that vary considerably in size from the standard brick. It is therefore advisable, before laying out the drawings for the front of a building that is to be faced with face brick, to obtain by actual measurement the exact size of the bricks that it is desired to use, so as to make the openings in the wall, especially the heights, of sizes that are multiples of the brick size. It is also necessary to know the exact size of the bricks to be used when stone or terra cotta are used in connection with the face brick, to make the heights of the stone or terra-cotta courses equal in height to a given number of brick courses so that the horizontal joints shall coincide.

**18. Sizes of Standardized Brick.**—There are a number of other standardized sizes of face brick, the names and the approximate sizes of which are given herewith. These sizes are obtained from catalogs of prominent manufacturers and show the variations in sizes which are sold under the same name.

NAMES AND SIZES OF FACE BRICK	
NAMES OF BRICK	APPROXIMATE SIZE INCHES
Real Roman .....	18 × 2 × 6
	17½ × 1½ × 5½
	18 × 1½ × 6
Norman .....	12 × 2½ × 4
	11⅞ × 2¼ × 4
Roman .....	12 × 1½ × 4
	11½ × 1¾ × 4
	11⅝ × 1⅝ × 3⅞
English .....	8⅞ × 2⅞ × 4⅞
	7¾ × 2½ × 3½
Standard .....	*8⅞ × 2¼ × 4⅞
	8 × 2¼ × 3¾
	8¼ × 2¼ × 4
	8⅞ × 2⅞ × 4
Split .....	8 × 1⅞ × 4
Pony .....	6 × 1 × 2¾

\* Standard recommended by National Brickmakers' Association.

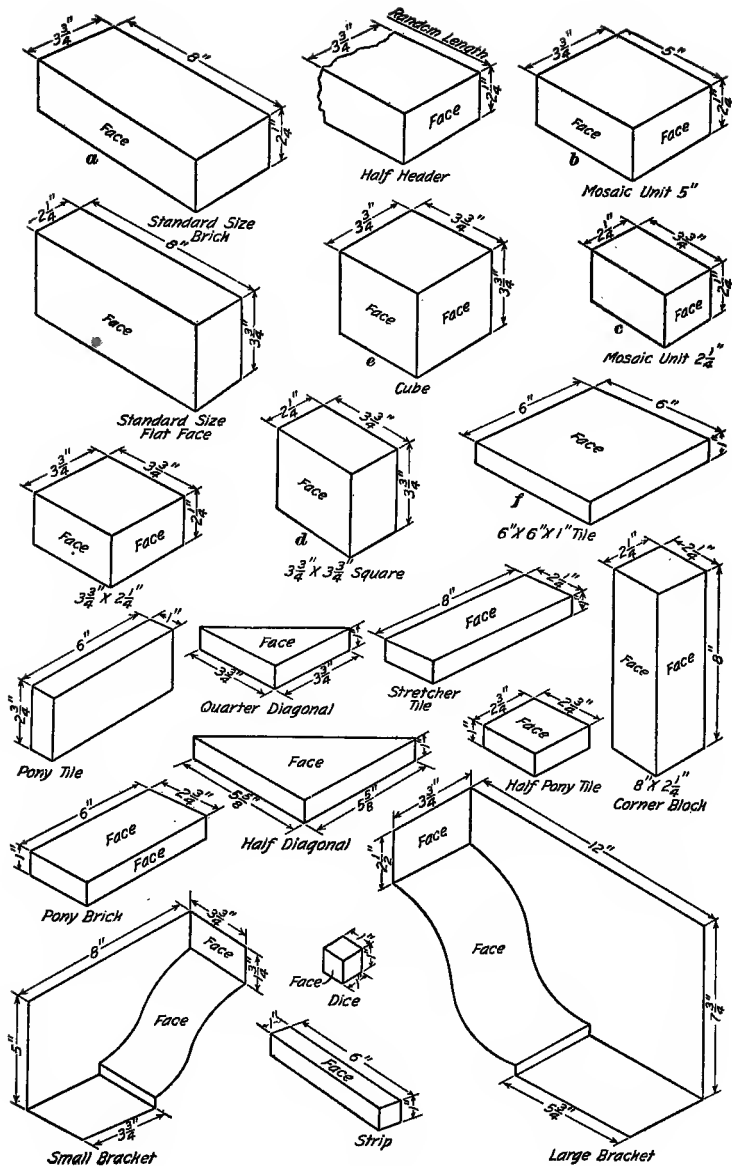

FIG. 12

**19. Special Shapes.**—Besides these standardized sizes and shapes, there are many special shapes made for use in pattern work. Some of these special shapes are shown in Fig. 12. The sizes of these units are marked in the illustration.

By using the standard-sized brick *a* with the 5-inch unit *b* and the  $2\frac{1}{4}$ -inch unit *c*, reproductions of the interesting Persian pattern-work such as shown in Fig. 59 can be made.

The square piece *d*, measuring  $3\frac{3}{4}$  inches by  $3\frac{3}{4}$  inches, is used in turning the corner of a border of bull-headers, or rollocks, as shown at *a* in the panel in Fig. 60. The cube *e*, Fig. 12, is used in turning the projecting corner in a course of rollocks, as shown in the upper corners of the brick flower boxes in Fig. 49. The square brick or tile *f*, Fig. 12, 6 in.  $\times$  6 in.  $\times$  1 in. in size, is used in positions such as shown in the ornamental bands at the tops of the bay windows in Fig. 63.

These special shapes save the mason a great deal of cutting and insure better results in laying out the work; also, they can be used in different colors than those used in the field so as to produce contrasts both in form and color.

**20. Tile.**—Tile are made of clay similar to that of which face brick are made and have, to a large extent, the same texture and coloring. Enameled and decorated tile are made in numerous shapes, colors, and designs. Patterns made of tiles are often used very effectively in connection with brickwork.

These tile are manufactured of the sizes and surfaces given in the accompanying list:

SIZES AND SURFACES OF TILE	
SIZE. INCHES	SURFACE
12 $\times$ 12 $\times$ 1 .....	Smooth
9 $\times$ 9 $\times$ 1 .....	Smooth
9 $\times$ 6 $\times$ 1 .....	Smooth
8 $\times$ 8 $\times$ 2 .....	Rough and semismooth
6 $\times$ 6 $\times$ 1 .....	Rough, smooth, and semismooth
6 $\times$ $2\frac{3}{4}$ $\times$ 1 .....	Rough and semismooth
4 $\times$ 4 $\times$ 1 .....	Smooth
$2\frac{3}{4}$ $\times$ $2\frac{3}{4}$ $\times$ 1 .....	Rough and semismooth
Half diagonal of a 6" $\times$ 6" .....	Rough and semismooth
Quarter diagonal of a 6" $\times$ 6" ..	Rough and semismooth

The rough tile has a decidedly rough texture on its face and is used for the floors of porches and terrace walks as well as for wall decoration in connection with rough-textured brick.

BRICK TEXTURES

**21. Rough Textures.**—A rough texture is commonly produced by mixing a coarse material such as grit or small



FIG. 13

pebbles with the clay, or by cutting the brick with wires when molding it, or by both methods. Fig. 13 shows a brick that is artificially roughened by the introduction of grit and pebbles in the clay. Another example of a brick surface containing pebbles is shown in Fig. 14.

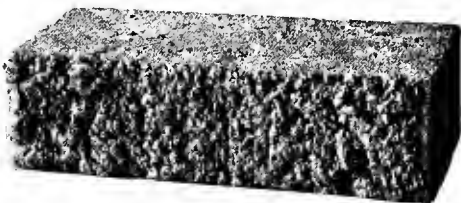

FIG. 14

The surfaces are also roughened by cutting the brick, when molding it, with wires, which drag and tear the soft clay surface, as shown in Figs. 15 and 16. Such brick is called *wire-*

*cut* brick. When the wire cuts the brick from one end to the other a surface is produced such as is shown in Fig. 15. This

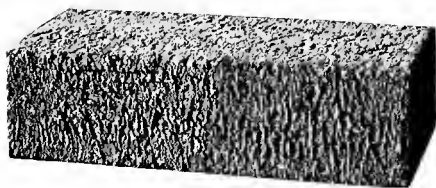

FIG. 15

brick is called an *end-cut* brick. When the wire is drawn from one long edge to the other, a surface like that shown in Fig. 16 is produced. This brick is a *side-cut* brick. The

brick shown in Fig. 13 has been roughened not only by the use of a coarse ingredient in the clay but by a subsequent scratching which produced the vertical marks shown on some of the bricks. Figs. 15 and 16 show a brick with a medium-rough surface.

An example of a rough brick surface, which is due to irregularity in burning during the processes of manufacture, is shown in *clinker* brick which has been cracked and twisted out of shape by the flames in the kiln. This brick, which in the past was generally sent to the rubbish heap, when used with taste and skill forms an artistic wall surface that possesses character and interest. A portion of a wall built of clinker brick is shown in Fig. 17.

**22. Smooth Textures.**—A smooth brick may be either a *pressed* brick, which is pressed by machinery into an accurate shape with edges absolutely true, or a *wire-cut* brick, which has the largest surfaces cut by the wires of the brick-cutting machine, while the other faces are all perfectly smooth. The edges of a wire-cut smooth brick are not as true as those of a pressed brick and consequently the brick when set has not that mechanical appearance which is characteristic of pressed-brick work. An example of a wall laid up with a smooth-textured brick is shown in Fig. 18.

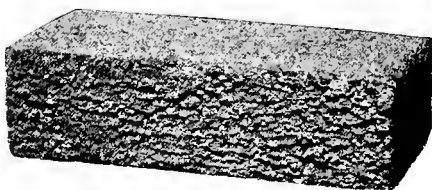

FIG. 16

**23. Effect of Texture.**—A wall built of bricks that are perfect in shape, absolutely smooth, uniform in color, and laid up with fine even joints, is not only very expensive to build but is very mechanical and inartistic in appearance. This fact is appreciated by architects and designers, and the best modern brickwork is constructed with brick which has more or less roughness of surface and variety of color, and of which the individual bricks are not mechanically perfect in form. With



FIG. 17

brick of this description, properly selected and laid, a wall can be laid that will have character, brilliancy, and interest. Such a wall will not appear hard and set; the color will not be monotonous, and the surface having some texture will give a play of light and shadow that will enliven the appearance of the wall and add brilliancy to the color.

By using some of the rougher-textured brick, new brickwork can be built so as to have a great deal of the charm of ancient work which is so much admired. One of the greatest charms

of the brickwork of the old colonial houses lies in the slightly rough texture and the soft color tones of the brick units.

**24.** At a distance from the building, the particular texture of the brick units is lost, but the effect of the rougher textures

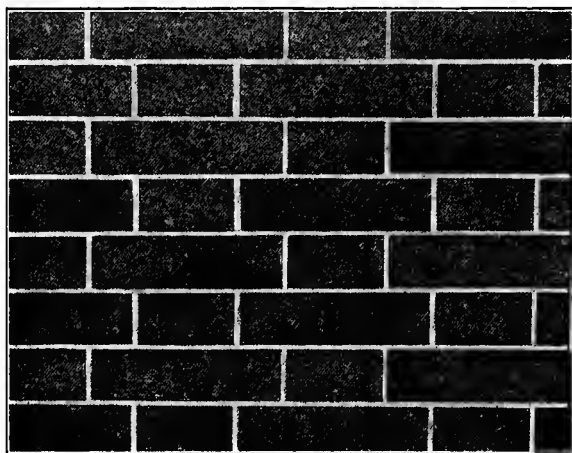

FIG. 18

is to soften the color of the mass of the brickwork and to do away with the glare which often occurs when the brick units are very smooth in texture.

**25.** Modern face bricks are generally burned so that they are almost vitrified and will not absorb moisture. Dust from the atmosphere which may lodge on the rough surface of the brick will therefore not be absorbed but will be washed off by rain, thus leaving the color of the brick fresh and clear.

---

#### BRICK COLORS

**26. Causes and Varieties of Brick Colors.**—Bricks in the United States and in Europe are naturally red in color, although, in some parts of the United States, clay is found that produces a yellow-colored brick. The bricks made in China and Japan are generally of a slaty-blue color.





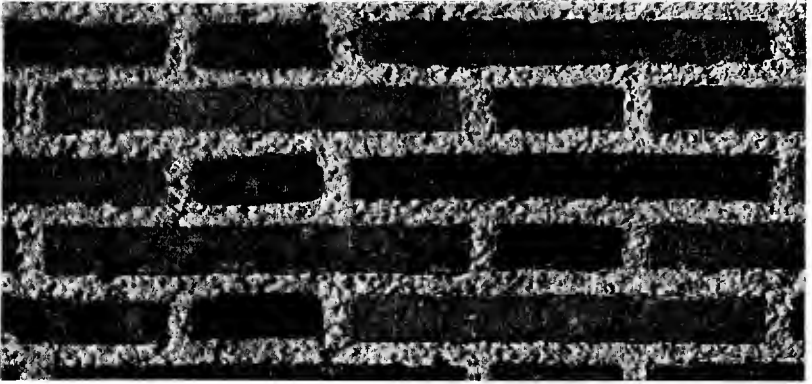

*By courtesy of Fiske & Co., Inc.*

FIG. 19

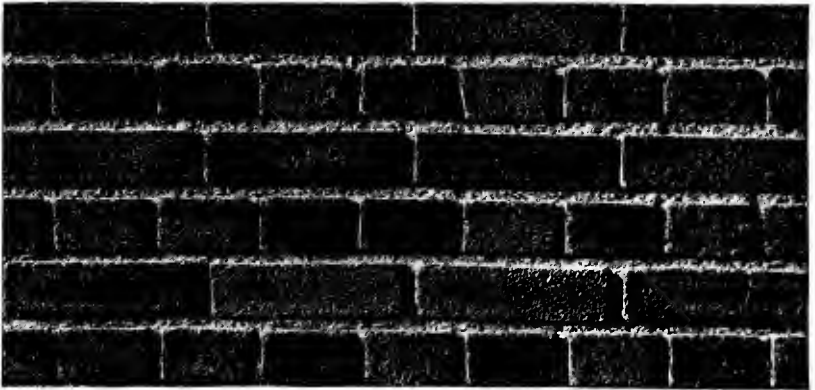

*By courtesy of Fiske & Co., Inc.*

FIG. 20



*By courtesy of Fiske & Co., Inc.*

FIG. 21

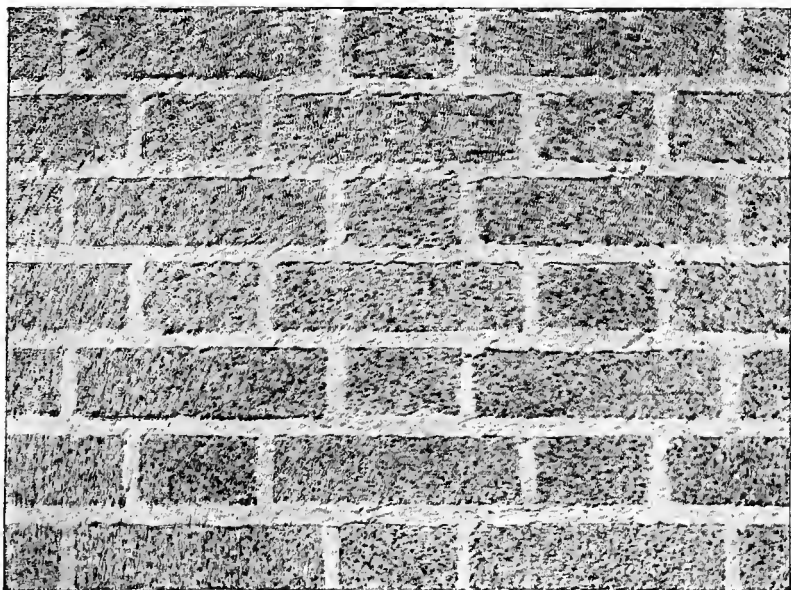

*By courtesy of Hydraulic-Press Brick Co.*

FIG. 22





*By courtesy of Hydraulic-Press Brick Co.*

FIG. 23



*By courtesy of Hydraulic-Press Brick Co.*

FIG. 24



The presence of iron, magnesia, lime, and other materials in the clay causes the different colorings in the finished brick. Iron in the clay will produce such colors in the brick as light yellow, orange, red, dark blue, and purple, according to the amount of iron present in the clay and the heat at which it is burned. Magnesia gives a brown color; magnesia and iron together, a yellow color; lime and iron together, a drab color.

Different clays contain these elements naturally, and by skillfully mixing selected clays, bricks can be made in a large variety of colors without the use of artificial coloring materials.

The degree of heat at which the bricks are burned has a great effect upon the color of the brick. This is well illustrated in the case of common bricks, which are taken from the old-style kiln with colors varying from a light salmon color to dark blue, according to the amount of heat to which they have been subjected.

The colors in which modern bricks are made are *reds*, varying from light pink to deep red; *buffs*, varying from a light cream color to deep, rich browns; *browns*, which vary from a light brown to a dark brown. There are also blues, purples, greens, and various fancy colors. Examples of some of these colors are shown in the colored illustrations in this Section.

There are generally variations in the face color of the same brick which give an interesting appearance to the individual bricks and also to the brick field. Such brick is shown in Figs. 19, 20, 21, and 22.

The bricks sometimes have iron spots on the surface, as shown in Figs. 23 and 38, or mottles, as shown in Figs. 24 and 29. The surface is sometimes glazed. In short, there is a great variety of texture and color from which the architect may choose, and the success of the choice will depend upon his taste and experience.

**27. Judging Effects.**—The color or texture of the completed wall can never be correctly judged from the color or texture of a single brick or even from a number of bricks laid up, as the atmosphere and the distance of the wall surface from the eye greatly affect the appearance of the brick. The

best way to judge the effect of a given brick in a building is to see a building built of the same kind of brick, which often can be done.

When a wall of the desired brick cannot be seen, a small sample wall of the chosen brick and mortar is laid up with a certain bond and width of joint. If this sample wall is satisfactory, the combination is adopted and used. If, however, the sample does not meet with approval, other bricks, mortar, joints, and bonds are tried by building small sections of wall until a satisfactory combination is discovered.

In the show rooms of brick dealers, a variety of such sample walls can generally be seen, which will assist the architect and the client in selecting a satisfactory combination.

#### MOLDED BRICK

28. Ornamental brickwork may be formed of plain brick which is built so as to project and form cornices and

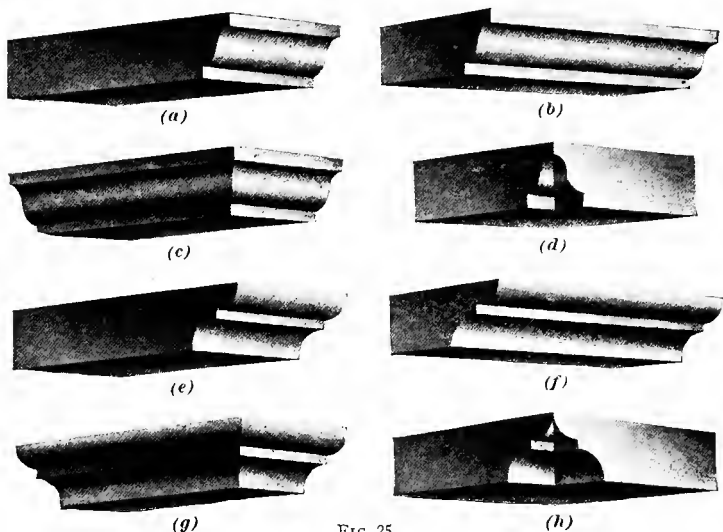

FIG. 25

string-courses in the manner shown in Figs. 2, 6, and 7, or by the use of bricks which are molded into various shapes.



These bricks are made in a large variety of shapes so that many architectural details such as cornices, string-courses, panels, window sills, columns, and pilasters can be made of them.

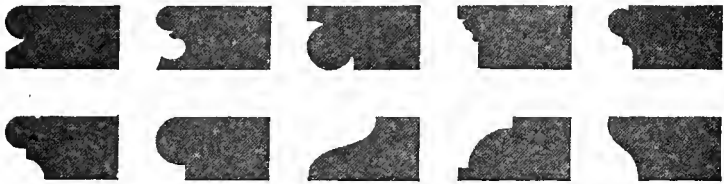

FIG. 26

The projection of molded brick details must necessarily be small, but several courses of brick can be projected over each other so as to produce a satisfactory total projection in the entire cornice.

The units in which molded brick is made are of such a size that they can readily be laid up with standard face brick and the horizontal joints can be maintained at each course or two.

Some of the more common and useful shapes that are made in molded brick are shown in Fig. 25. In (a) is shown a mold-

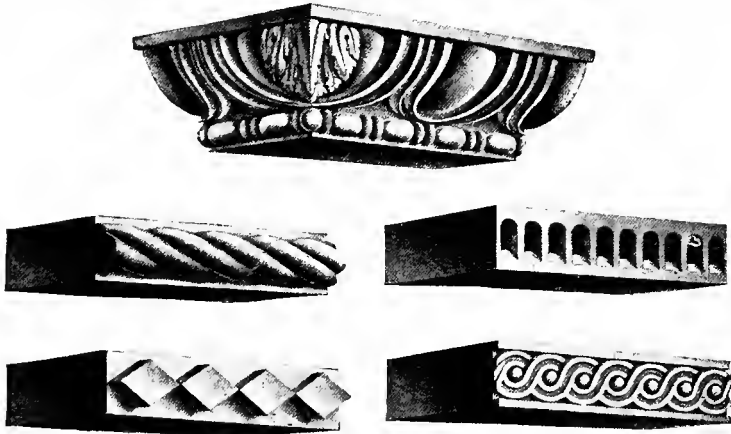

FIG. 27

ing known as a *cyma recta*, or crown, molding. These bricks are generally made in four forms to fit them for use in a string-course. A header for this molding is shown in (a); in (b) is a stretcher, in (c) a projecting corner, and in (d) a sunk corner.

In *e*, *f*, *g*, and *h* are shown the four molded bricks required for another form of crown molding, called a *cyma reversa*.

Several profiles of molded brick commonly used are given in Fig. 26. The necessary headers, stretchers, and corners are also made for these moldings.

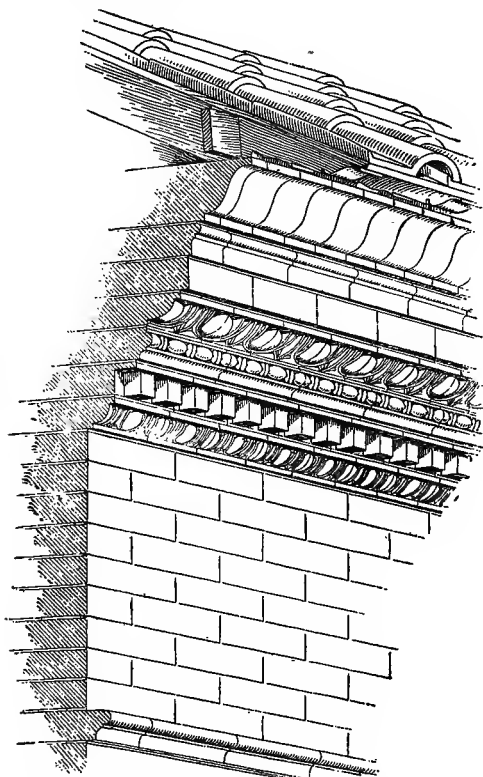

FIG. 28

Ornamental band courses having ornament in relief or projection are shown in Fig. 27.

**29.** Molded brick are generally made with a smooth finish and are used to the best advantage with smooth-faced brick. They cannot very well be used together with the rough-textured brick that are so popular at the present day.



*By courtesy of Hydraulic-Press Brick Co.*

1 L. T. 31F § 11

FIG. 29



Molded brick of rough texture are, however, sometimes made of the same color and texture as the brick used in the brick field; an example of such brick is shown in the moldings over the door and window in Fig. 49.

**30. Molded Brick Cornice.**—A cornice composed of molded brick, together with plain face brick, is shown in Fig. 28. As before stated, the projection of each course must be small, and the total projection cannot be so great as that of a cornice made of stone, terra cotta, or wood.

---

### MORTAR AND MORTAR JOINTS

**31. Effect of Mortar and Mortar Joints.**—The mortar joint and the mortar are essential factors in the appearance of finished brickwork. In fact they are almost as important as the color and the texture of the brick in their effect upon the appearance of the wall. Where a very thin joint is used, as in Figs. 23 and 24, the principal effect is caused by the *color* of the mortar.

The color of the mortar may be in contrast with the color of the brick, as in Fig. 29, thus forming a network of contrasting color over the entire surface of the wall, or it may be similar in color to the brick itself, as in Fig. 24, in which case the wall will have a uniform, and possibly a monotonous, color effect.

The wider the joints the greater will be the effect of the color of the mortar upon the wall. In an extreme case, such as shown in Fig. 19, where the bricks used are 18 in.  $\times$  2 in. on the face and the mortar joints are 1 inch in width, the areas of the brick and the mortar showing in the face of the wall are as 2 is to 1, or, the area of the mortar in the face of the wall is one-third of the entire area of the wall. It will readily be seen that in such a case the color of the mortar would be extremely important.

**32.** Whether the mortar in the joints is flush with the surface of the bricks or is slightly recessed also makes a great difference in the appearance of the wall. If the mortar is kept

flush with the surface of the bricks, as shown in Figs. 18 and 19, the effect of the joint depends entirely upon the texture and color of the mortar. When, however, the joints are recessed, or *raked*, each brick casts a small shadow on the mortar joint, making a dark line below and on one side of each brick, which makes the bricks stand out separately and also emphasizes the joints, as shown in Figs. 13 and 20.

**33.** The mortar may have a smooth or a rough texture. In Figs. 24 and 29 the mortar shows a smooth texture, in Figs. 13 and 20 a rough texture. The rough-textured mortar has a brilliancy due to the alternation of light and shade, and is generally used with a rough-textured brick.

**34. Composition of Mortar for Face Brick.**—For fine joints and for smooth-faced brick, a mortar made of fine sand, cement, and lime is satisfactory; and mortar colors may be added to give the mortar the desired tone or color. This mortar, however, is unsatisfactory for a joint  $\frac{1}{2}$  inch or more in width, as it is too soft and pasty and would squeeze out between the bricks while they are being laid.

Practical experience has demonstrated that, with the proper kind of mortar, brick can be laid with a wide rough joint even more rapidly than with a narrow one.

**35. Materials Used for Making Mortar.**—Mortar for joints over  $\frac{3}{8}$  inch in width should contain a liberal proportion of fine pebbles,  $\frac{1}{4}$  inch or less in diameter, known to the building trade as *grit*, in addition to coarse sand, cement, and a small amount of lime putty or hydrated lime, and coloring matter if desired.

**36. Grit.**—Grit consists of small pebbles  $\frac{1}{4}$  inch or less in diameter, and should be screened so as to remove all sand. This material gives a characteristic texture to the mortar, as shown in the joints in Fig. 13. It also gives a body to the mortar which enables it to stand up under the brick until the cement sets.

**37. Sand.**—Ordinary bank or pit sand is satisfactory for dark-colored joints, but where white or light-colored mortar is required, either white sand or coarsely ground marble or limestone is used. For very fine white joints pulverized marble, called *marble dust*, is used. Sand from sea beaches is not a desirable sand to use for mortar unless it has been thoroughly washed. If it is not washed the salt is apt to appear on the face of the brickwork in the form of efflorescence.

**38. Cement.**—The best cement to use for all brickwork is standard Portland cement. For white mortar, however, a white Portland cement, which is made from white clay and limestone and possesses the qualifications of a standard Portland cement, is preferable.

**39. Lime.**—*Lime putty* adds to the whiteness of the mortar and also makes the mortar work more easily under the trowel. The lime should be well slaked and strained and allowed to stand for several days before it is used.

*Hydrated lime* is lime artificially slaked, and is sold in the form of a very fine powder. Under most conditions hydrated lime may be used instead of lime putty. It has the advantage that it can be used immediately, whereas lime putty requires several days for preparation.

**40. Coloring Materials.**—Most of the mortar colors employed to color the mortar used in laying and pointing face brickwork consist of mineral pigments, and are sold either as a dry powder or in the form of pulp or paste. The pulp colors seem to mix better with the mortar than the dry colors and are therefore preferable for the better class of work. Mortar colors, whether dry or in paste form, should never be mixed with lime until the lime has been slaked for at least 24 hours. The mortar color should in any case be thoroughly mixed with the mortar, and exactly the same amount of color used for a given quantity of mortar. If this is not done there will be variations in the color of the finished mortar joints which may not be desirable.

The color of mortar appears to be much darker when the mortar is wet than when it is dry. It is therefore advisable to mix a sample of the mortar containing a measured quantity of mortar color and try it out on a small portion of the wall. This, when dried out, will show the true color of the mortar in connection with the brick. If the first experiment is not satisfactory, other mixtures of mortar can be tried until a good color is obtained. The proper proportion of mortar color having thus been determined, all mortar that is afterwards prepared should be mixed in exactly the same proportions.

**41. Suggestions for Coloring Mortar.**—The following are useful suggestions as to the color of mortar to be used with different colored brick.

With brick of varying shades of *red*, a cream-gray mortar, as shown in Figs. 19 and 20, is effective. Where a darker effect is desired a dark reddish brown mortar may be used.

With *gray* brick, light-gray mortar, such as shown in Fig. 24, is good. Where a thicker joint is used, a raked joint is very effective. For a darker effect, mortar of a dark gray or a dark brown, such as shown in Fig. 29, is a good color to use.

For brick of golden or buff shades, a cream-gray or warm-gray mortar is effective.

**42. Formulas for Mixing Mortar.**—The following formulas for mortars are the result of careful experiments and will make excellent mortars of the colors named. The term *part* as here used refers to any unit that may be used as a measuring unit. For small batches of mortar a mason's bucket of 14 or 16 quarts capacity may be used and each bucketful considered as a part. For large quantities of mortar a tight barrel, such as a Portland cement barrel, may be used as a measure of one part. It is very important that exactly the same proportions of the ingredients be used in all the batches or else each batch will show a different color in the wall, which may be very undesirable.

One of the small batches made with a bucket as the unit, mixed according to one of the following formulas, should be enough mortar to lay 100 bricks.



FORMULA I. LIGHT-GRAY MORTAR:	PARTS
Quarter-inch grit .....	2
Coarse sand .....	5
Portland cement .....	1
Hydrated lime .....	$\frac{1}{2}$

FORMULA II. CREAM-GRAY MORTAR:	
Quarter-inch grit .....	2
Coarse sand .....	5
Portland cement .....	1
Hydrated lime .....	$\frac{1}{2}$
* Yellow powder mortar color.....	$\frac{1}{8}$

FORMULA III. DARK-GRAY MORTAR:	
Quarter-inch grit .....	2
Coarse sand .....	5
Portland cement .....	1
Hydrated lime .....	$\frac{1}{2}$
Yellow powder mortar color.....	$\frac{1}{2}$
Black paste mortar color.....	$\frac{1}{16}$

FORMULA IV. DARK-BROWN MORTAR:	
Quarter-inch grit .....	2
Coarse sand .....	5
Portland cement .....	1
Hydrated lime .....	$\frac{1}{2}$
Yellow powder mortar color.....	$\frac{1}{3}$
Brown paste mortar color.....	$\frac{1}{3}$
Black paste mortar color.....	$\frac{1}{50}$

FORMULA V. LIGHT-GRAY MORTAR:	(For a small batch)
Quarter-inch grit .....	2 buckets
Coarse sand .....	5 buckets
Atlas cement .....	1 bucket
Hydrated lime .....	$\frac{1}{2}$ bucket
Yellow powder mortar color.....	1 pint

**43. Amount of Mortar Required.**—The amount of mortar required for laying face brick will, of course, depend upon the thickness of the joint used. For joints  $\frac{1}{4}$  inch to  $\frac{3}{8}$  inch thick between standard-sized brick, about .4 to .6 cubic yard of mortar will be required for laying 1,000 brick. For joints

$\frac{1}{2}$  inch to  $\frac{5}{8}$  inch thick about .8 to .9 cubic yard, and for joints  $\frac{3}{4}$  inch to 1 inch thick about 1.2 to 1.6 cubic yards, will be needed to lay 1,000 brick. One barrel of cement and 3 barrels of sand will make about 12 cubic feet, or .44 cubic yard, of mortar.

**44. Finish of Joints.**—It is always best to finish the joints of the face brickwork as the work progresses rather than

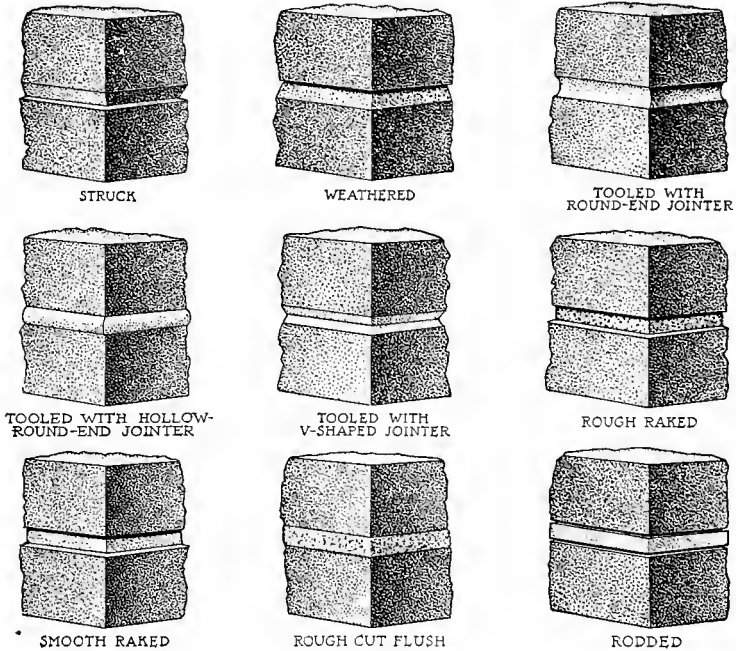

FIG. 30

to rake out the joints and point them after the wall has been built. There are several ways of finishing the joints, which have become standard, all of which have some practical or artistic merit. They are illustrated in Fig. 30.

A **struck joint** is one that is made by drawing the point of the trowel along the joint and smoothing out the mortar so that the upper edge of the joint is flush with the brick while the lower edge of the joint is slightly back of the upper edge of the lower brick.

A **weathered joint** is one made by drawing the trowel along the joint so that the mortar at the lower edge of the joint is flush with the lower brick while the mortar at the upper edge of the joint is slightly back of the lower edge of the brick above the joint.

A **tooled joint** is made with a special tool called a *jointer*, which is described later. There are three forms of the tooled joint, which are made with jointers of different shapes. These three joints are marked as tooled with round-end, hollow round-end, and **V-shaped jointers**.

A **raked joint** is formed by scratching out the mortar to a depth of from  $\frac{1}{8}$  inch to  $\frac{1}{2}$  inch. This is done with special tools, which will be described later. A raked joint may have a rough finish or a smooth finish.

A **rough-cut flush joint** is formed by allowing the mortar to ooze out beyond the face of the brick and cutting off the surplus with a quick stroke of the trowel just after the mortar has begun to set, but in such a manner as to avoid smoothing the surface of the mortar.

A **rodded joint** is one that is made by cutting a line along the upper and lower edges of the joint with the edge of a trowel.

**45. Examples of Finish of Joints.**—A *rough-cut flush joint* is illustrated in the wall shown in Fig. 19. In this example, real Roman rough-textured brick are used with a flush joint 1 inch in width. This type of brickwork is found in ancient Roman buildings.

Fig. 20 illustrates the use of a rough-textured brick and a rough raked joint. The brick are laid up in English bond. In Fig. 29, smooth-textured mottled brick of standard size are shown laid up in Flemish bond with smooth raked joints of dark-brown mortar.

**46.** A mortar joint that is decidedly black or white is to be avoided. The black joint has a deadening or dulling effect on the general color of the mass of brickwork, while the white mortar looks too bright and new and generally makes too sharp a contrast in color with the brick.

**47. Tools Used in Finishing Joints.**—The *trowel* is used to make the struck joint and the weathered joint and, in connection with a straightedge, in forming the rodded joint.

The tooled joint is made with a tool called a *jointer*, *jointing tool*, or *jointing steel*. Forms of jointers are shown in Figs. 31, 32, and 33. The jointer shown in Fig. 31 consists of a piece

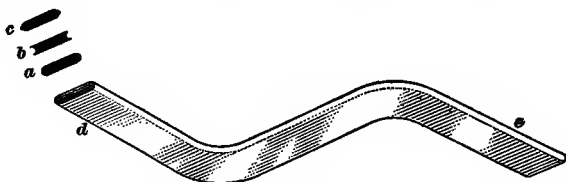

FIG. 31

of flat steel bent as shown and with the edges *d* and *e* made of different shapes so as to produce the different forms of joints. Three of these shapes are shown at *a*, *b*, and *c*. The mortar joint is finished by drawing the jointer along between the edges of the bricks and pressing it against the mortar. The jointer forms the joint according to the shape of its edge. The edge *a* makes a hollow joint, the edge *b* forms a *beaded* or projecting half-round joint, while the edge at *c* is used to form a *V-shaped* joint. These joints are shown in Fig. 30.

**48.** Another form of a jointing tool is one that has a circular cross-section and a tapering point, as shown in Fig. 32.



FIG. 32

The fine point at *a* is used in pointing the finer joints, and the thicker part *b* is used for coarser joints. This tool is used only for hollow joints.

A similar jointer, also circular in section, is shown in Fig. 33 (*a*). The jointer tapers so that it can be used for joints of different widths,

**49. Tools for Raking Joints.**—A simple device for raking the mortar out of the joints to form a raked joint is shown in Fig. 33 (b). It consists of a flat steel bar with projections on each end which are the shape of the joint to be raked. The same tool can be used for raking two different sized joints. The projection *a* or *b* is drawn along in the joint and cleans out the mortar according to its length and width. The shoulders *c* prevent the joint being scratched out beyond the desired depth.

**50.** • A patented device for raking out and striking a raked joint is shown in Fig. 33 (c). This tool consists of a handle *a*

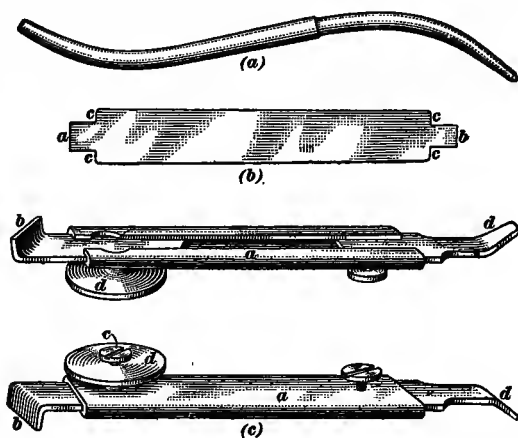

FIG. 33

into one end of which *joint scrapers*, or *plows*, *b* can be fitted. Different sizes of plows are used according to the thickness of the joints. The plow can be extended to cut any depth of joint required, and is held firmly to the handle by means of a screw bolt *c*, the head of which is shown above the wheel *d*. This wheel runs along on the face of the brick as shown in Fig. 34 at *a* and regulates the distance that the plow enters the joint. Thus, when the tool is run along the face of the wall it rakes the mortar out of the joint to the desired depth, forming a rough raked joint.

In the other end of the handle, Fig. 33 (c), *strikers d* of different widths can be secured. These strikers are used to smooth the raked joint, as shown in Fig. 34 at *b*, thus forming a smooth raked joint.

**51. Pointing.**—Pointing consists of scraping the mortar out of the joints to the depth of about  $\frac{3}{4}$  inch and filling them with fresh mortar. The joints are raked out with a piece of

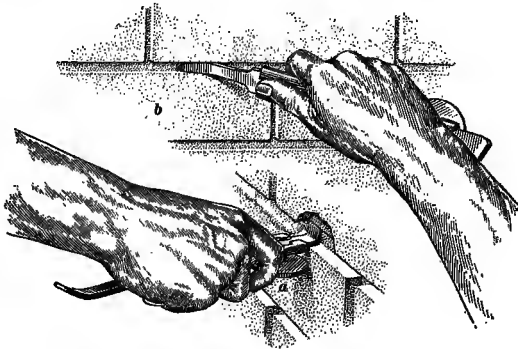

FIG. 34

wood or iron or with a tool such as has just been described. After raking, all the loose mortar should be brushed out of the joints and the joints made wet so that the pointing mortar will stick to the brickwork. The same quality of mortar should be used as for face brickwork and the joint may be finished in any of the styles shown in Fig. 30.

## BOND

**52. General.**—The appearance of a brick surface depends not only upon the color and texture of the brick and the mortar but, to a very large extent, upon the manner in which the brick is bonded or laid in the wall.

**Bonding** is primarily a means of construction and is a method of tying the bricks together in such a way as to make the wall structurally solid and strong.

**Face bond** is the bond used on the face of the wall, and it is often independent of the structural bond of the backing.

In discussing bond or bonding in connection with face brickwork the face bond only is referred to.

**53. Bonds.**—There are four structural bonds that are also largely used in face brickwork. They are the *running* bond, the *Flemish* bond, the *English* bond, and the *Dutch* bond.

**54. Running Bond.**—The simplest bond, as far as appearance is concerned, is the *running* bond, which shows only stretchers on the face of the wall. These stretchers break joint as shown in Fig. 13. This arrangement of the bricks does not provide headers to tie the face brick to the backing, hence the tie must be provided by other means. The methods employed to tie the face brick to the backing are by means of metal ties; by clipping off the interior corners of the face brick

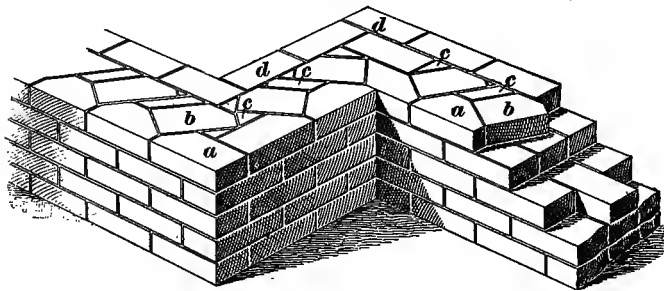

FIG. 35

and laying the interior bricks diagonally to form a bond, as shown in Fig. 35; by cutting the face brick in half lengthwise and *toothing* the backing into the space thus formed, as shown in Fig. 36.

**55. Flemish Bond.**—The *Flemish* bond consists of alternate headers and stretchers in each course, each header in one course being directly over the center of the stretcher in the course below. This bond is shown in Figs. 17, 18, 19, 21, 22, and 29, and is very decorative in its effect. It is particularly effective when the headers are slightly darker than the stretchers, as in Figs. 19 and 22.

A variation in this bond is illustrated in Fig. 37, where the stretcher consists of two standard-sized stretchers with a blind joint between them.

**56. English Bond.**—The *English* bond consists of alternate courses of headers and stretchers and is a substantial-

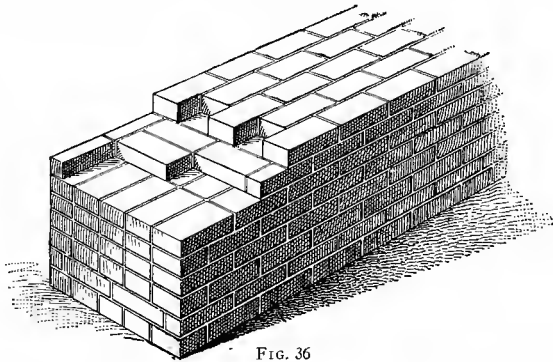

FIG. 36

looking and fine-appearing bond. It is also simple and easy to lay up.

An example of this bond is shown in Fig. 20. A great deal of the historic brickwork of England is laid in this bond and it is a very popular bond in the United States. Often, in practice,

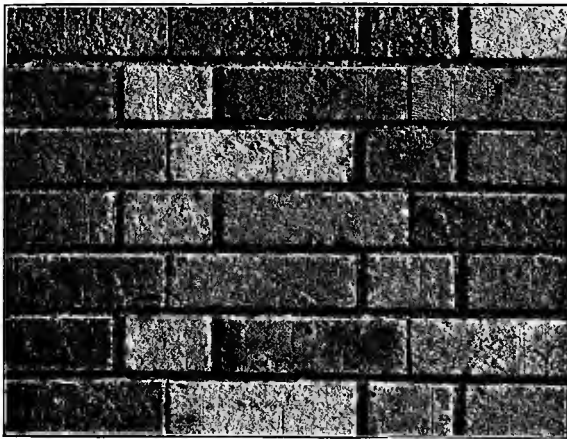

FIG. 37

only the headers of every third or fourth course in the face brick extend into the backing to form a bond or tie, or some-



times only a portion of the course extends into the backing. The stretchers in all courses are in line vertically.

**57. Dutch Bond.**—The *Dutch* bond is a modification of the English bond and it also consists of alternate rows of headers and stretchers. In the Dutch bond the stretchers in one course break joints with the bricks in the next stretcher course above and below, and the headers are all centered on the stretchers either above or below them. The result of this



FIG. 38

arrangement is that the vertical joints form a diagonal pattern over the entire face of the wall, which has a very artistic appearance.

This bond is also known as the *Dutch cross bond* or the *English cross bond*, and is illustrated in Fig. 38.

**58. American, or Common, Bond.**—The bond called American, or common, bond is made by introducing a course of headers, called a *bond course*, every fifth or sixth course. This bond is the one generally used in building ordinary brick walls in the United States, and is also sometimes used as a face bond.

**59. Miscellaneous Bonds.**—Besides the bonds that have just been described, which may be considered as the

standard bonds used in brickwork, there are many other bonds, most of which are variations of these standard bonds. These more complicated bonds, however, are used merely for their decorative effect and should properly be considered under the subject of Pattern Work.



(a)

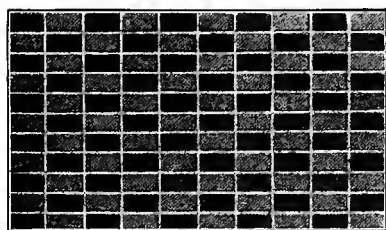

(b)

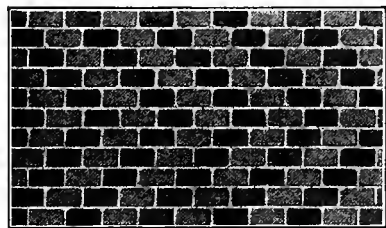

(c)

FIG. 39

stretchers, while the patterns in (b) and (c) are formed entirely of headers. The brick in (a) must be tied to the backing as described for running bond. The brickwork in (b) and (c) can easily be tied to the backing by allowing headers to extend back into the wall as frequently as may be desired. Most of the headers shown in (b) and (c) are bats or half-bricks. These patterns may be formed by the

## PATTERN WORK

**60. Pattern Work on Wall Surfaces.**—Pattern work is formed by arranging the bricks and joints according to some pleasing design, also by varying the color, texture, and sizes of the brick. The bonds already shown give simple and more or less pleasing patterns, and some of the more complicated bonds will next be considered.

**61. Variations of the Running Bond.** Three variations of running bond are shown in Fig. 39 (a), (b), and (c). The pattern at (a) is formed of

arrangement of the joints only or by the use of bricks of different colors or textures.

**62. Variations of the Flemish Bond.**—The arrangement of the joints in Flemish bond does not permit of any modification but there is a great variety of pattern work that can be produced by the use of different-colored brick. Some of these patterns are shown in Fig. 40. The pattern in (c) is the one which is very popular and is used frequently.

**63. Variations of the English Bond.** Variations in pattern, using English bond, are made by using bricks of different colors as shown in Fig. 41.

**64. Variations of the Dutch Bond.**—Variations in pattern in the Dutch bond can be made only by the use of different-colored bricks. Two patterns are shown in Fig. 42.

**65. Miscellaneous Patterns.**—There are innumerable patterns that can be made on wall surfaces by manipulating the jointing and the colors of the bricks.

A great number of patterns are formed by using a course of stretchers alternating with a Flemish course. Several of these patterns are shown in Fig. 43. In (a) is shown a pattern that will have the effect of vertical lines of differing thickness;

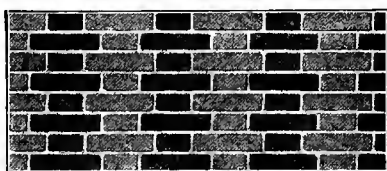

(a)

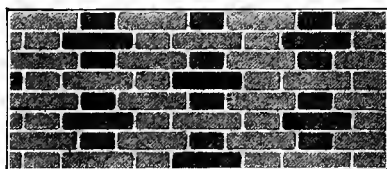

(b)

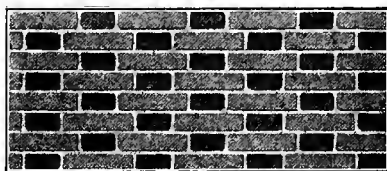

(c)

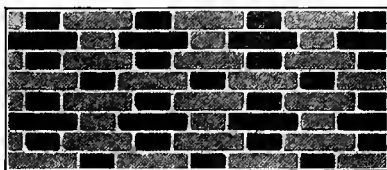

(d)

FIG. 40

at (b) is a pattern of small crosses extending over the entire field; (c) shows a pattern in which all the headers are darker in color than the stretchers.

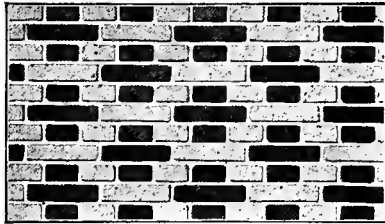
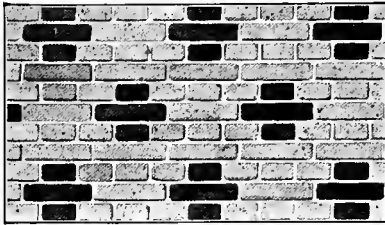

FIG. 41

The pattern shown at (d) has a diamond effect. The pattern at (e) is one that is formed largely by the joints and has a refined and artistic effect. A portion of wall laid up with this design, but without a difference in the brick coloring, is shown in Fig. 44.

In this particular example, rough-textured brick of various shades of reds, browns, and soft purples, laid up with a cream-gray flush joint, gave the finished brick surface an artistic and decorative effect.

Other patterns are shown in Figs. 45, 46, and 47. Intricate and exceedingly interesting patterns are shown in the Persian minaret in Fig. 8.

Various designs for wall patterns will be found in the illustrations shown in this Section and the student will find it interesting and profitable to study them and determine how they are formed.

The simplest designs to execute, so far as the mason is concerned, are those in which standard-size brick are used, and in which the pattern work does not interfere with the

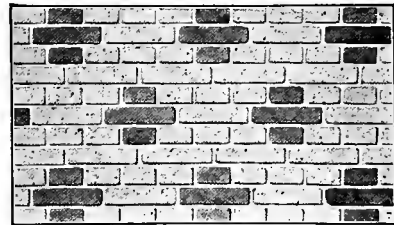
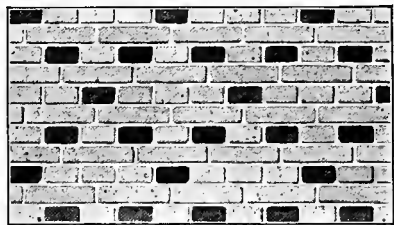
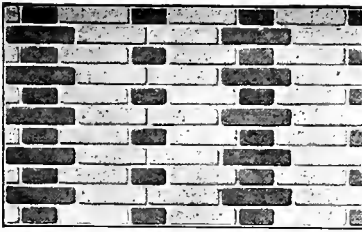
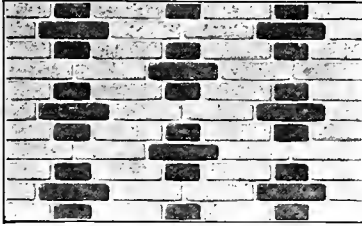

FIG. 42



(a)



(b)

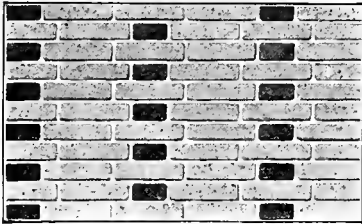

(c)

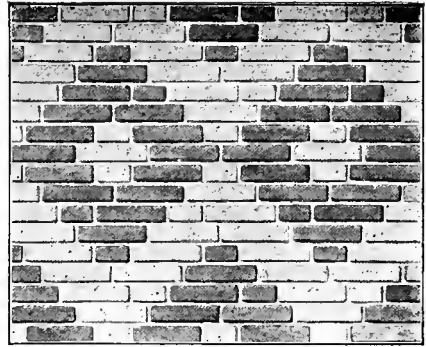

(d)

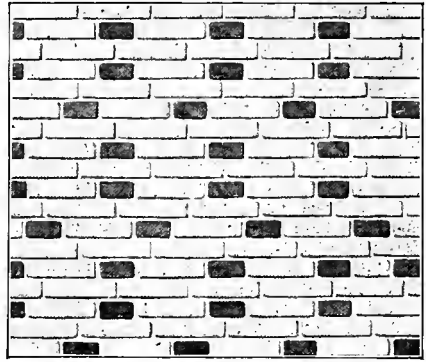

(e)

FIG. 43



FIG. 44

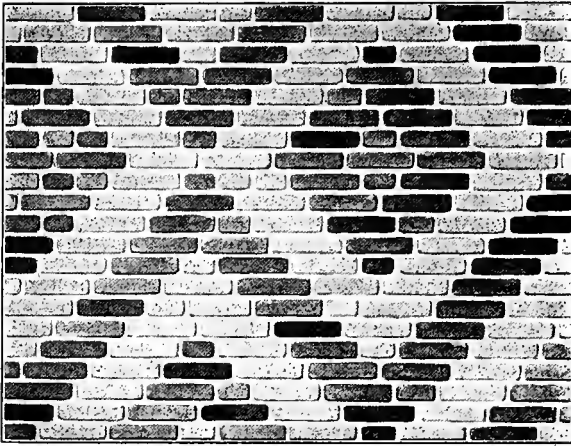

FIG. 45

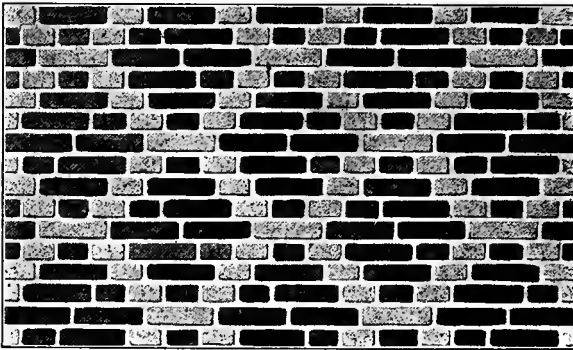

FIG. 46



FIG. 47

particular bond used in the general field. An example of this is shown in Fig. 48.

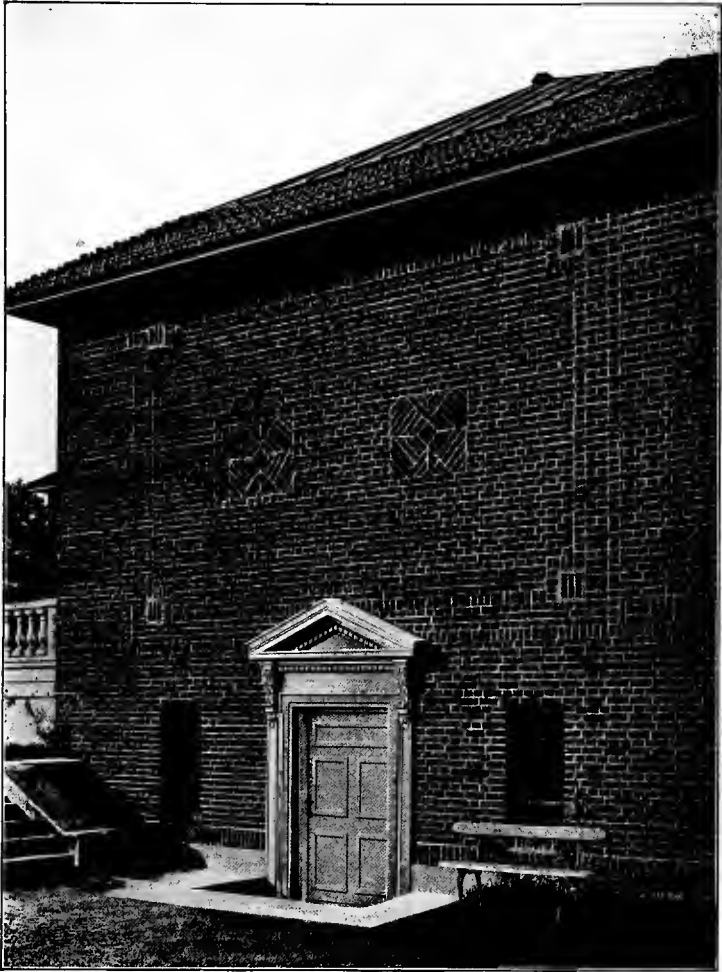

FIG. 48

**66.** When diagonal patterns such as shown in Figs. 43, 44, 45, and 46 are used, care should be taken in designing the façade so that the pattern will have a proper relation to the

openings and corners of the wall. Thus, the pattern should meet both sides of a window symmetrically, as shown in



By courtesy of Fiske & Co., Inc.

FIG. 49

Fig. 44, and make a neat finish at the corner of a wall, as shown in Fig. 49.

**67. Herring-Bone Pattern.**—A pattern known as the *herring-bone* pattern, which is very much used in paneling, is



illustrated in Fig. 50. Designs such as shown in (a) are adaptable to running bands or friezes. The designs in (b) and (c) are useful for panels. These patterns, particularly (b) and (c), are also very much used in floors made of brick or tiles.

**68. Friezes and Bands.**—As a rule, it is best to keep the patterns used in large brick fields rather quiet and subdued and to emphasize some band or frieze or some particular spot by a more interesting and elaborate treatment. The plainness of the field will then set off to advantage the more complicated design of the frieze or spot, and produce a more satisfactory result. This method of treatment is illustrated in Figs. 51, 58, and 63, where ornamental bands are used in connection with plain fields, also in Fig. 1, where a plain field in Flemish bond is surmounted by handsome friezes or bands of patterned work which crown the wall. Fig. 51 illustrates the effectiveness of ornate bands or friezes over a plain wall.

**69.** Designs for bands in face brickwork are given in Figs. 52, 53, and 54. Fig. 52 shows a *chain pattern* formed in Flemish bond, Fig. 53 is a *chain pattern* in English bond, and Fig. 54 is a more complicated pattern showing the use of special-sized brick, which have already been described. These effects are produced by differences in the color of the brick as well as by the bonding. Other designs for bands are shown in Figs. 1, 64, and 65.

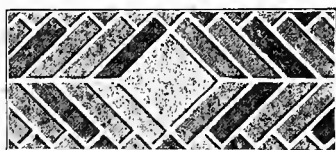

(a)

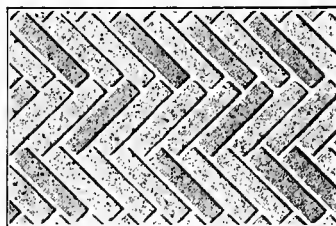

(b)

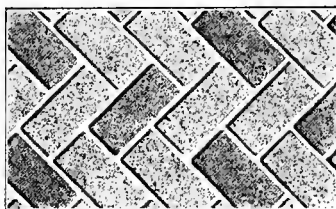

(c)

FIG. 50

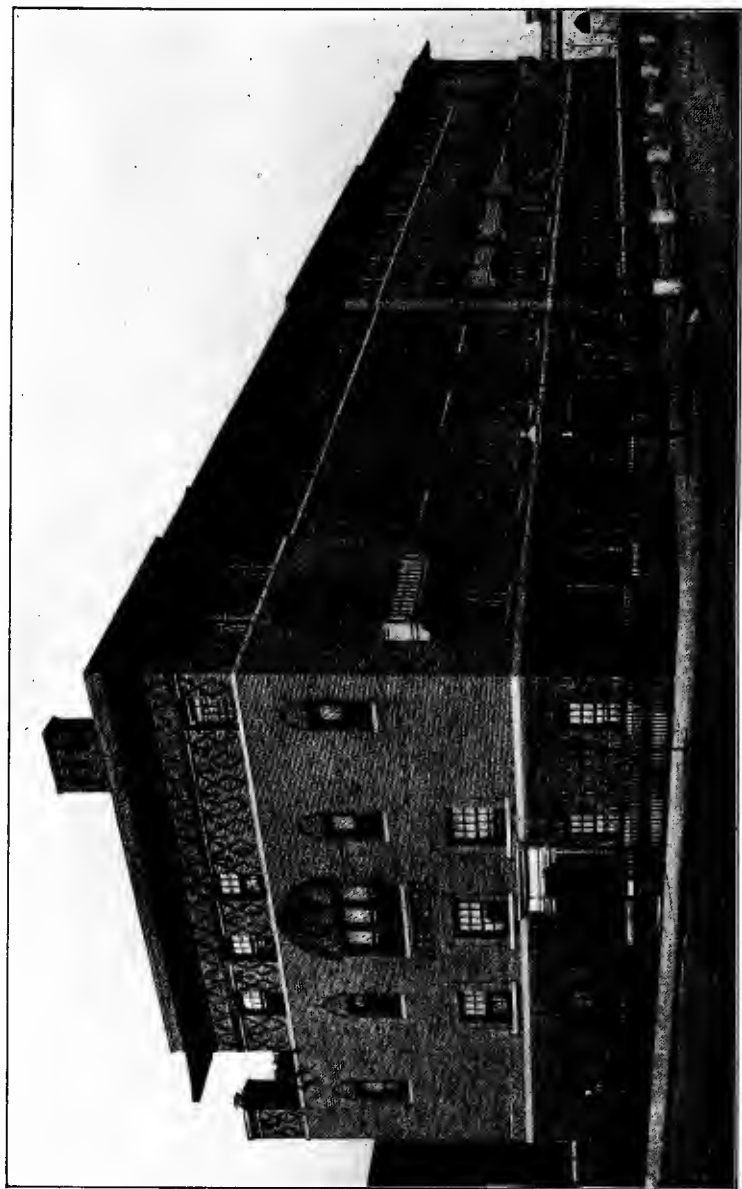

FIG. 51

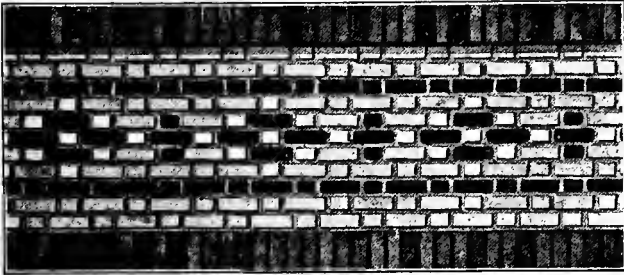

FIG. 52



FIG. 53



FIG. 54

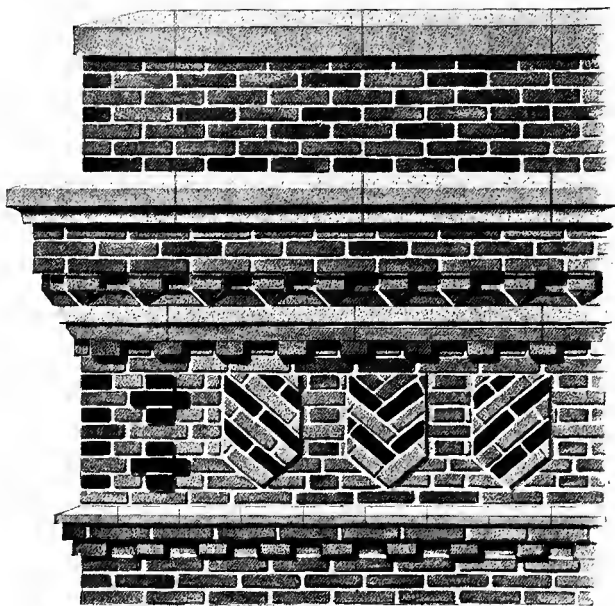

FIG. 55

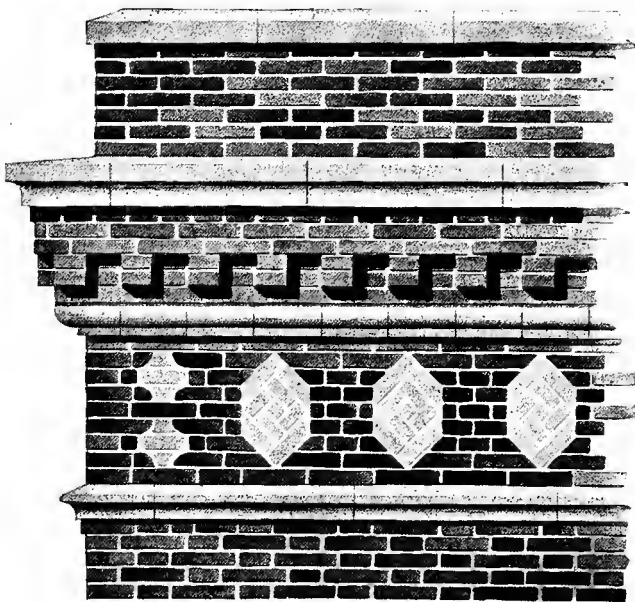

FIG. 56

Friezes containing special designs made of brick cut to various shapes and representing shields, hexagons, etc. are illustrated in Figs. 55 and 56.

**70. Borders.**—Borders are used around large panels such as frequently occur on school buildings, theaters, and factory buildings, which, if not especially treated, would appear uninteresting. Fig. 48 suggests a treatment of a large panel and border in a brick building which makes it interesting without using special brick and at very little expense more than would be incurred in making a plain wall.

A design for a border is shown in Fig. 57 in which the bands *a, a* as well as the corner pieces *b* are raised above the field about  $\frac{1}{2}$  inch. The headers may be black headers where so indicated or else brick of a slightly darker color than the rest. The pieces *b, c,* and *d* may be tiles or bricks of special shape and different color from the brickwork of the field. A handsome border, used around a panel on an interior wall, is shown in Fig. 58.

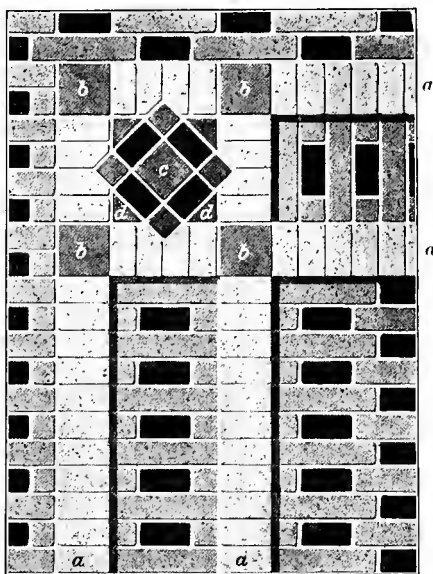

FIG. 57

**71. Panels.**—Panels are shown in Figs. 48, 58, 59, and 60. In Fig. 48, a large panel is formed by a border of headers and rowlocks, with the corners emphasized by bricks set on end, in soldier courses. Two points or spots in the field of this panel are brought out by special patterns. This wall is an example of a wall laid in English bond where the stretchers are darker



By courtesy of Fiske & Co., Inc.

FIG. 58

than the headers. The entire wall has a distinctly interesting brick character.

Fig. 58 illustrates a plain brick panel surrounded by an interesting border.

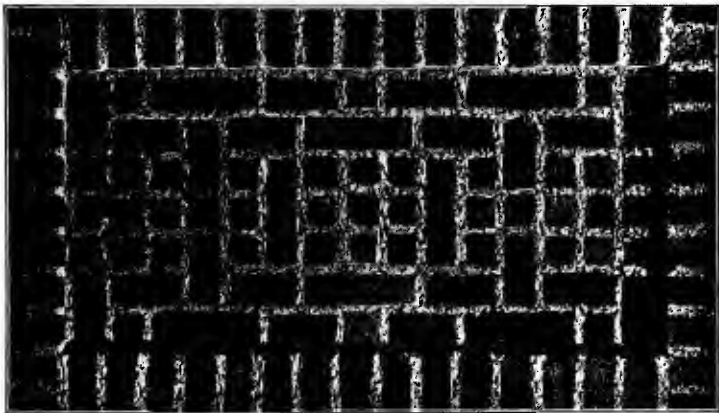

FIG. 59

The panel in Fig. 59 is an excellent example of modern brickwork in imitation of the ancient Persian work. There

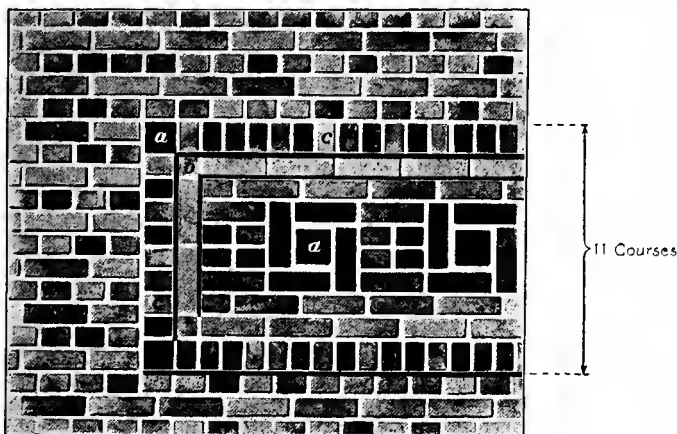

FIG. 60

are three sizes of units used in this design. The standard-size stretcher, 8 in.  $\times$  2 $\frac{1}{4}$  in., is one unit, a second is 5 in.  $\times$  2 $\frac{1}{4}$  in., and

the third is  $2\frac{1}{4}$  in.  $\times$   $2\frac{1}{4}$  in. The joint used in this design is  $\frac{3}{8}$  inch thick, so that three rowlock bricks in the border and two joints equal one stretcher, two of the rowlocks plus one joint equal the 5-inch unit, and one rowlock equals the third

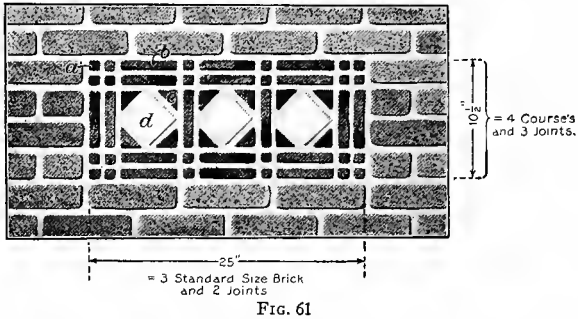

FIG. 61

unit. This combination of units lends itself to many handsome patterns. An application of this kind of panel work is shown below the frieze in Fig. 1.

Fig. 60 illustrates a simple panel design in which the border *c* has been projected slightly beyond the face of the wall. The pieces *a* and *b* are special sizes of brick made for this pattern.

The panels shown in Figs. 61 and 62 depend upon the proper selection of colors in the bricks and upon the contrast in color between the mortar and the brick. In Fig. 61 small dice 1 inch

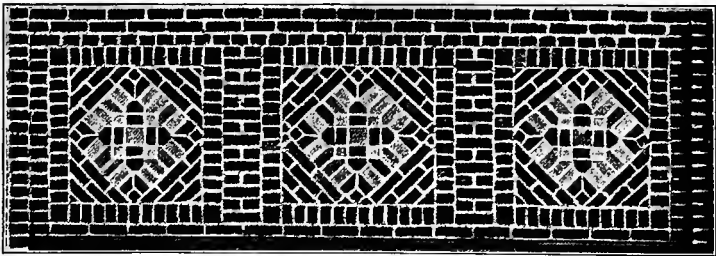

FIG. 62

square are shown at *a*, pony size brick at *b*, triangular cuts at *c*, and square tile or brick at *d*.

The application of panels to the decoration of a building is shown in Fig. 63 immediately beneath the cornice, between the



uppermost windows, and in the frieze at the top of the bay windows.

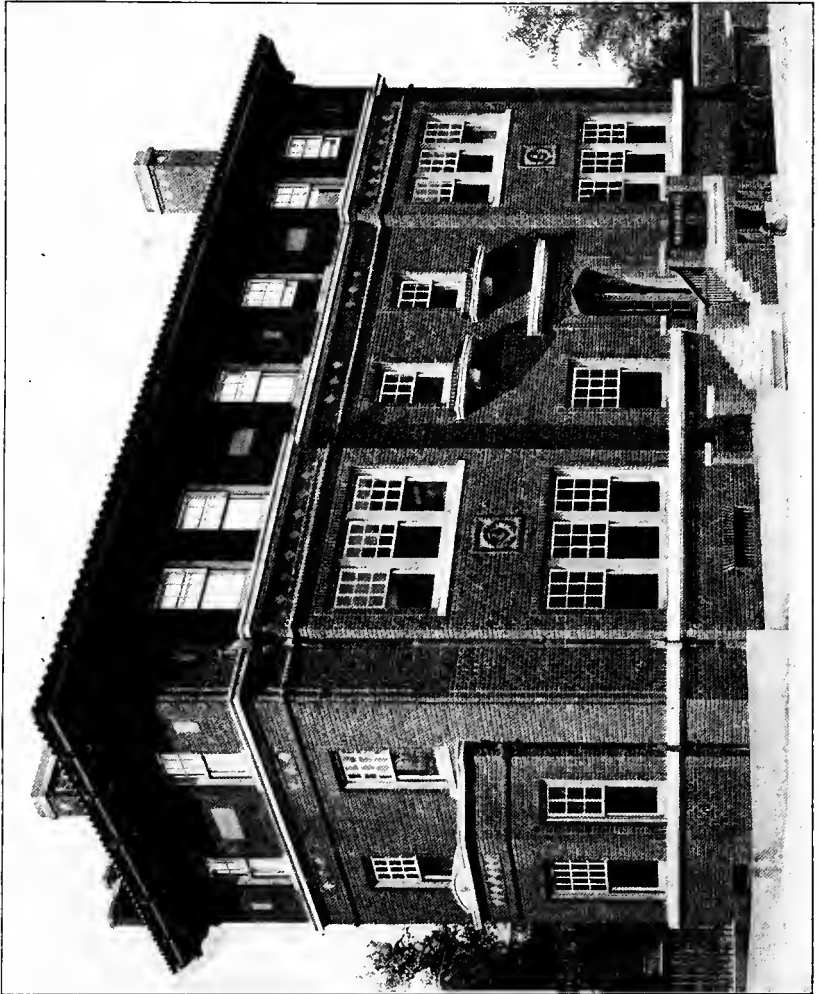
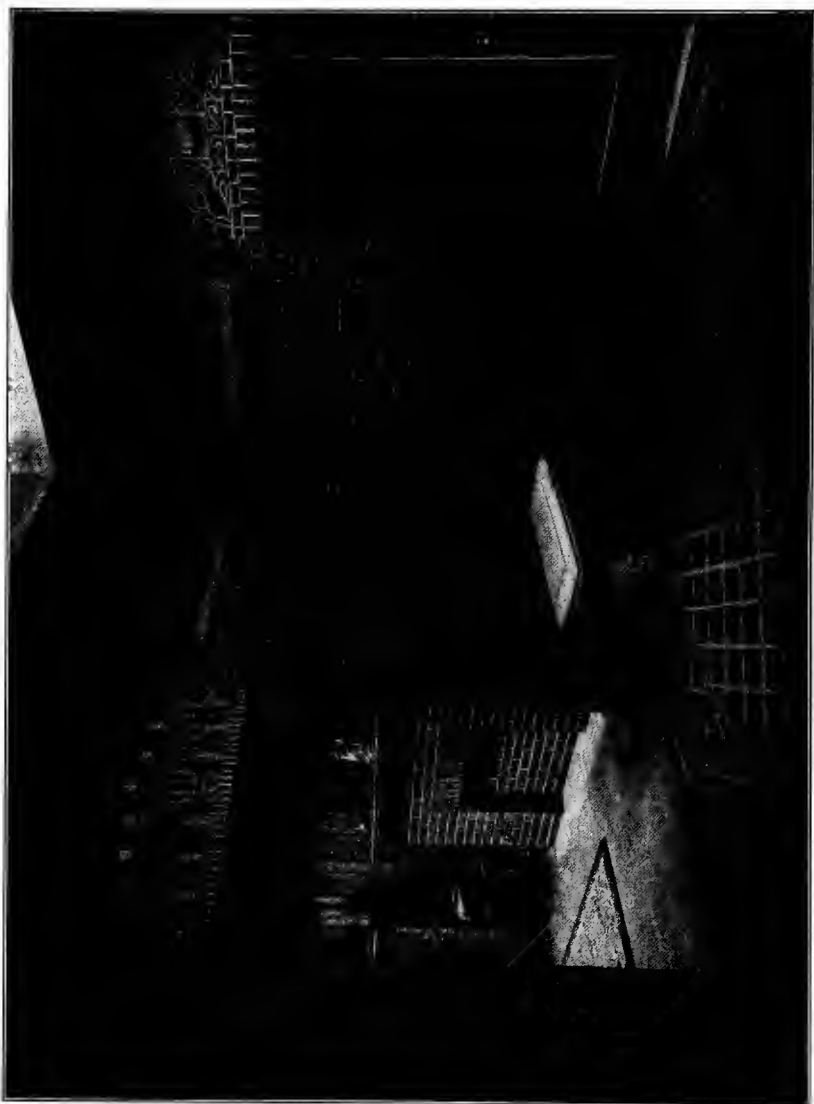

FIG. 63

**72. Interior Walls.**—With the great variety of color and texture found in modern brick, interior walls can be designed that are very suitable for vestibules, conservatories,



*By courtesy of Fiske & Co., Inc.*

FIG. 64



*By courtesy of Fiske & Co., Inc.*

**FIG. 65**

cafés, etc. Fig. 58 illustrates the use of brick in the main entrance lobby of a large business building, in which many of

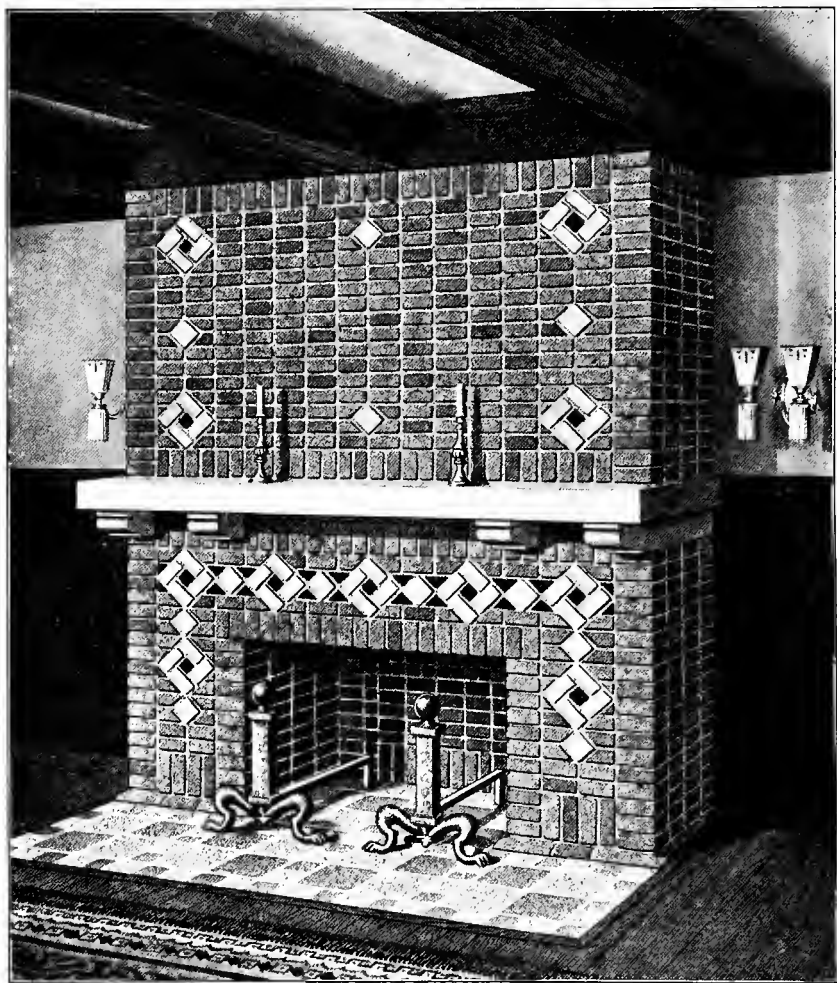
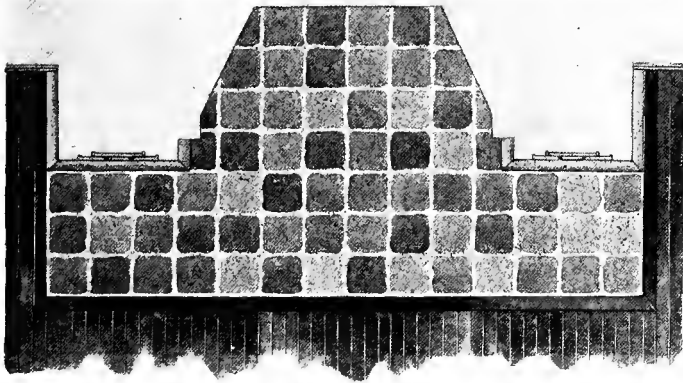
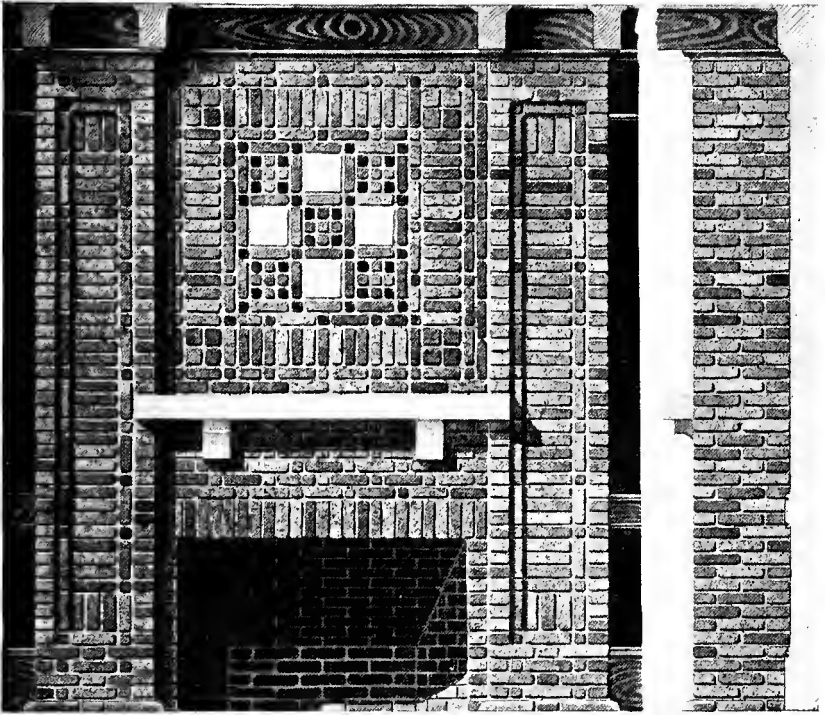

FIG. 66

the resources of face brickwork are exhibited. A soldier course occurs at the base of the wall, above which is shown a running bond of headers and a rowlock course. These form



a wainscot effect. Above this the wall is paneled, the panel being surrounded by a handsome border. The field of the panel is in Dutch bond. The trim or finish of the door openings is formed of molded brick similar in character to that of the other brick in the wall.

Figs. 64 and 65 show the treatment of walls in face brick as used in the display rooms of a prominent brick manufacturer. These walls show a variety of friezes and bonds, the use of soldier courses, friezes, bands, panels, etc. They also illustrate the use of Flemish, English, and Dutch bonds in the field, and the various special shapes of brick. Tile inserts showing dolphins and a ship are used over one doorway in Fig. 64 and an ornamented brick panel is shown over the other doorway.

**73. Fireplaces.**—Face brick are frequently used with artistic effect in the construction of fireplaces and chimney breasts. Figs. 66 and 67 are examples of such fireplaces. By the proper selection of colors and sizes of brick these fireplaces make very effective and ornamental features for sun parlors, living rooms, dens, and libraries.

---

## ORNAMENTAL BRICKWORK

**74.** As has been stated, **ornamental brickwork** may be formed of plain brick which is built so as to project and form cornices, string-courses, and other ornamental features, or by the use of bricks which are molded into special shapes before baking.

An example of plain bricks used in forming a cornice is given in Fig. 68 in which an approximation to a classical cornice has been built as far as can be done with brick. The bottom of the cornice begins with a rowlock, or bull-header, course. Most of the projections are necessarily slight. The bold projection in the upper part of the cornice is made with especially large bricks or units which support the crowning member. A band course at the middle of this cornice is formed by building the bricks in a diagonal position so that the corners project.

This causes a variation of light and shade on the different surfaces and a wavy effect in the mortar joints. This cornice is crowned by a terra-cotta molding course. Just below the cornice are seen three tiles inserted in the brick field.



FIG. 68

Another example of ornamental brickwork formed of projecting bricks is given in Fig. 69. In this figure the outer ring of the arch is a rowlock arch and inside of this arch is a dentil

course, so called from its resemblance to a row of teeth. The string-course above the doorway is supported upon brackets

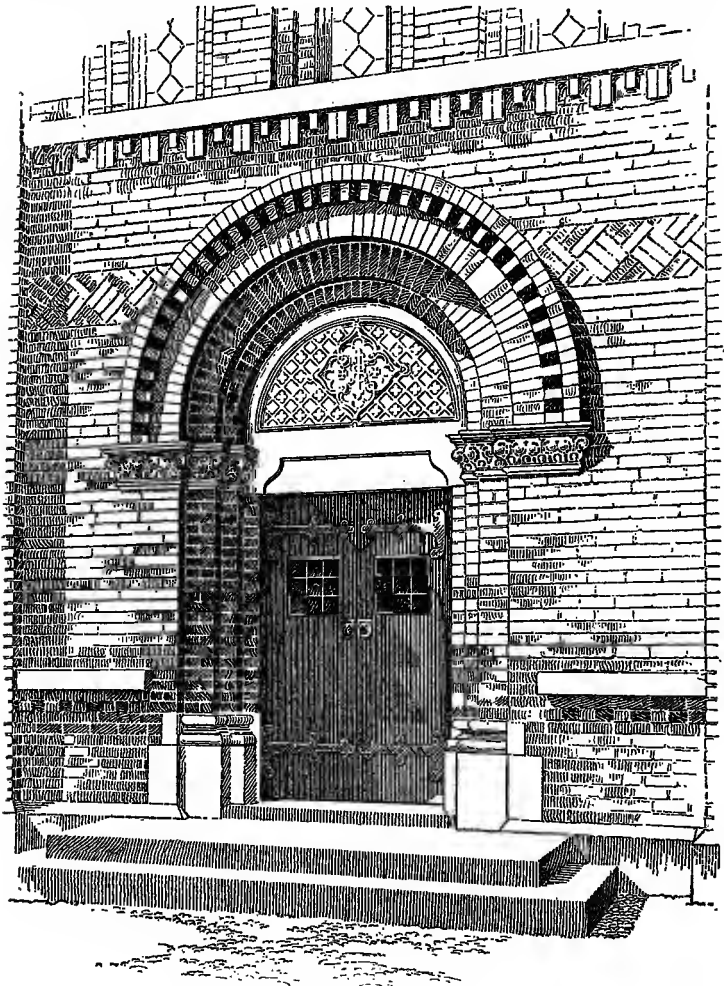

FIG. 69

formed of bricks placed on end alternating with bull headers.

Figs. 6 and 7 show examples of Italian ornamental brickwork of the 13th and 14th centuries.



# ARCHITECTURAL TERRA COTTA

---

## ADVANTAGES, USES, AND DESIGN

---

### INTRODUCTION

**1.** **Terra cotta** such as is used for facing walls of buildings, forming cornices, columns, sills, and lintels over openings, etc., is technically known as *architectural terra cotta* to distinguish it from the form known as *structural terra cotta*, which is used in the construction of walls, partitions, floor arches, and enclosures for steel columns in fireproof buildings.

**2.** All terra cotta is made of clay or shale, which is ground with water in a mill, molded into shape, and then placed in a kiln and burned to a brick-like consistency. Architectural terra cotta is made of a better grade of clay than structural terra cotta and is so treated as to form a plastic mass that can be molded into forms of very intricate pattern. Great care is required in forming and handling the blocks, in finishing the surfaces, and in burning, to secure a product that will be free from defects and suitable for the purpose intended.

Although the process of manufacture has changed greatly in detail since terra cotta was first employed, about 600 B. C., the product as it comes from the kiln today is very much the same as that made by the ancients, who used this material for a variety of useful and ornamental purposes.

**3.** Terra cotta is extensively used for facings for exterior and interior walls of buildings, and for such purposes it is a durable, beautiful, and economical material.

Properly made terra cotta is fire-resistant, frost-proof, and weather-proof, in which characteristics it is superior to stone. It lends itself to a great variety of color effects and can be molded or ornamented with comparative ease to produce either plain or intricately ornamented work that will stand the wear and tear of centuries.

From the structural standpoint, terra cotta is a most desirable material to use on account of its durability and adaptability to many kinds of structures. It is equally adaptable to a building having masonry walls or one having a framework of steel or of reinforced concrete.

---

#### ADVANTAGES AND USES OF TERRA COTTA

**4. Facings for Walls.**—Terra cotta, when used as a facing for masonry walls, may be bedded in mortar and built into the wall in the same manner as stone or brick.

As a facing for a steel-frame or reinforced-concrete-frame structure, terra cotta is a desirable material, as the blocks may be designed and formed to fit the shape of the structural parts that support them. The blocks may be kept away from these parts a distance of from one to two inches to allow for irregularities in the structure, thus avoiding expensive cutting and fitting such as is often required when stone is used. In the forms of structures mentioned the terra cotta is usually attached to the supports by means of metal anchors, and the space back of the blocks is filled with masonry except in places where the terra cotta fits closely to the supports, in which cases the space may be filled with a cement grout.

**5.** An advantage that terra cotta has, when used as a facing for a reinforced-concrete building, is that the entire rough concrete structure can be built and completed on the inside before the terra cotta is applied. The terra cotta does not require to be bonded with the wall, piece by piece, as the wall progresses, but may be put in place afterwards and secured to the wall by means of metal anchors that have been previously built into

the wall. By this method, the terra cotta may be in the making at the factory while the building is being erected.

**6.** In addition to the employment of terra cotta for building fronts and for interior work, there is considerable demand for its use in cornices and balustrades to take the place of more expensive cut stone, copper, or perishable sheet metal, such as tin or galvanized iron.

**7. Fire-Resisting Qualities.**—Terra cotta is a good fire-resisting material, as it can stand the heat of a conflagration better than stone. It can therefore be used in office buildings and other structures where it is necessary to cover a steel frame with a material that will conceal and protect the steel and at the same time give a pleasing and permanent architectural finish to the structure.

**8. Weather-Resisting Qualities.**—As a weather-resisting material, architectural terra cotta is very superior. When properly glazed it is non-absorbent and is thus excellent for structures built in large towns and cities where smoke and dust are always in the atmosphere. Terra cotta can be so glazed that it is impervious to water, and buildings faced with it can be washed down whenever desired, and made to look as fresh as when new.

**9. Lightness in Weight.**—For special purposes where a saving in weight is necessary, terra cotta is especially useful, as in a dome where it is required that the structure shall be light in weight and at the same time durable and weather resisting.

**10. For Ornamental Work.**—Terra cotta as a material for ornamental work in buildings has several advantages over cut stone which make it especially desirable to use under some circumstances. One of these is that the sculptor who models any ornamental part of a building in terra cotta can be sure that his model will be accurately reproduced, because the process of casting terra cotta is a mechanical one by which the original model made by the sculptor is exactly copied in

the plaster mold and reproduced in the clay when pressed into the mold.

When stone is used, the sculptor makes a clay model from which a plaster cast is taken and this is copied by the stone carvers with more or less fidelity, according to their proficiency and the accuracy with which they can interpret the sculptor's original model. As a rule, sculptors themselves do not carve the stonework but are dependent for the excellence of the results upon the skill of the stone cutters employed by them.

**11.** Another advantage is that terra cotta can be glazed with any color desired, so that great variety in tint can be obtained; thus it is not dependent upon its natural color, like stonework, nor upon the color produced by the burning, as is the case with brickwork. The ability to glaze terra cotta with colors opens up a wide range of possibilities for the designer who appreciates the effectiveness of color in his designs. Color in terra cotta is not affected by time or weather. Though dimmed by dust or smoke, the material may be quickly restored to its original color by washing. Colored glazed terra cotta is called Faience or *polychrome* terra cotta, *polychrome* meaning many colored.

White, full-glazed terra cotta, described later, is especially useful for the fronts of buildings, for lining light-courts, or wherever it is desirable to reflect the light as much as possible.

**12. Economy.**—Terra cotta also has an advantage in economy, as it generally costs somewhat less than stone, and being lighter in weight requires less steel to support it.

Terra-cotta members having richness of detail, such as flutings, ornamental panels, belt-courses, elaborately modeled column capitals, or similar members, can be produced in duplicate at much less expense than in cut stone, each unit of which must be laboriously carved by hand. Even in the plain members that are often used as a facing, the blocks may be formed of practically one size and by the use of very few molds may be cast in great numbers, whereas in stone facings each piece requires to be cut and finished as a separate unit.

### DESIGN OF TERRA COTTA

**13.** In designing buildings in which architectural terra cotta is to be used, the architect should have a good knowledge of the nature of terra cotta, as well as of some of the peculiar conditions that govern its manufacture. Architectural terra cotta should be designed in accordance with the characteristics of the material itself even when it is used to resemble some other material, such as cut stone.

---

#### CHARACTERISTICS AFFECTING DESIGN

**14.** The characteristics of terra cotta that affect its use and design are, first, that terra cotta is a burnt product that shrinks and warps somewhat in burning. This characteristic makes it difficult to use large pieces of terra cotta in plain-surface work, as irregularities in the surface will not look well in the front of a building. This defect is largely overcome by using the terra cotta in medium-sized blocks so that the deformities will be small and practically negligible.

A second characteristic is that the clay of which the terra cotta is made lends itself readily to modeling or ornamentation. The use of modeling or ornament over the surfaces of terra-cotta work serves to conceal deficiencies due to warping and shrinking, and terra-cotta work containing considerable ornamentation always looks better than plain work. This modeling can be done quite easily and, after a mold has been made for a piece of ornament, a great number of similar pieces can be cast in the same mold. Hence, the oftener an ornament is repeated on a surface the less will be the cost of the terra cotta per piece, as the repetition of the same pattern will be much cheaper than the use of a number of different patterns.

A third characteristic is that very elaborate, bold, and projecting ornament for special positions can be easily made in terra cotta. The modeler makes the desired form in clay and the model is cut up into suitable-sized pieces, dried, glazed, and baked.

A fourth characteristic of terra cotta is that it can be colored in any desired tints and thus a field for design in color is opened to the designer.

A fifth feature is that it can be finished so as to resemble other materials, especially cut stone.

Thus terra cotta lends itself readily to ornamental treatment either of a bold or a delicate nature, to elaborate or delicate color effects, and to texture design.

---

#### PLAIN SURFACES

**15. Plain Blocks.**—Where plain blocks are used to obtain certain features, such as ashlar faces, plain piers, mullions and panels, they should be medium in size and carefully finished before drying, and the joints should be rubbed so that the two adjoining blocks will fit together with perfect accuracy. A wall composed of plain blocks that are even slightly warped will have an uneven appearance, but if the blocks are paneled, molded, or ornamented in any way that tends to make the wall irregular in appearance, the eye will not notice any slight warping that may exist.

The effect of the shrinking and warping in plain blocks of terra cotta, due to the heat of baking, is shown in the flat portion of the wall above the second-story windows in Fig. 1. If, however, this part of the façade had been built with blocks about 10 in.×16 in. or 12 in.×20 in. in size, as has been done in the panel between the first- and second-story windows, these blocks could have been made so that the slight irregularities of the surfaces and joints would not be apparent. In contrast with this example is the wall similarly treated in Fig. 2, in which the blocks are made small and the imperfections are thus reduced to a negligible quantity. In addition to making the blocks small, the edges of the blocks are beveled. This treatment also tends to conceal any imperfections in the joints due to warping. This style of design is not recommended for large surfaces as it is adaptable only for designs using a tile or diaper effect.

Fig. 3 shows a building with a terra-cotta façade having



FIG. 1

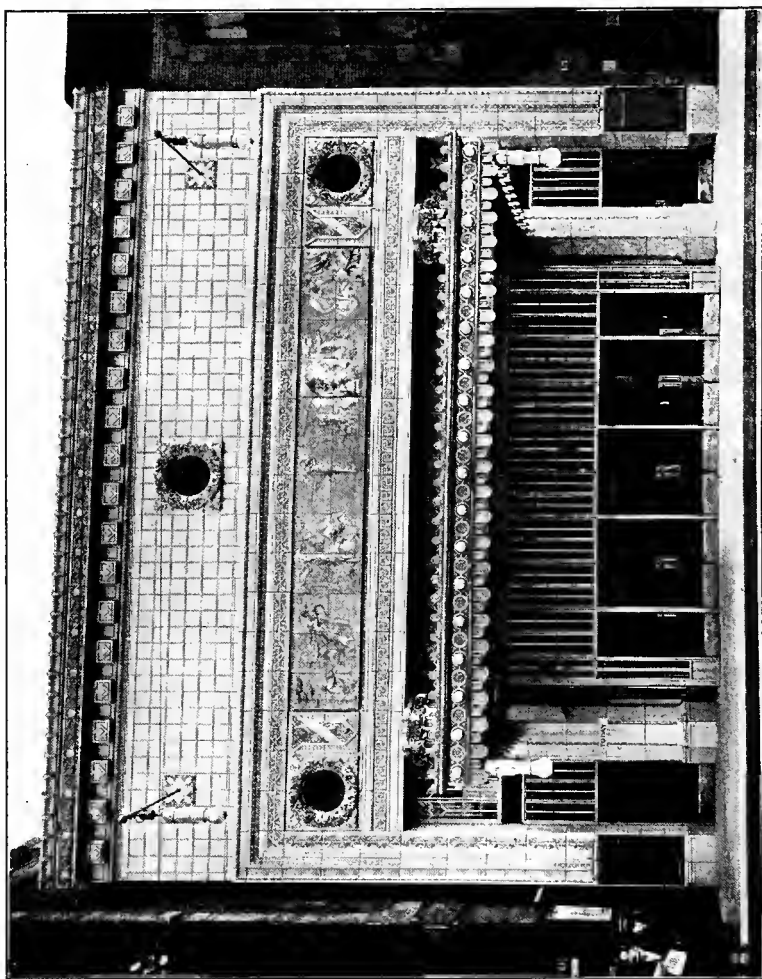

FIG. 2



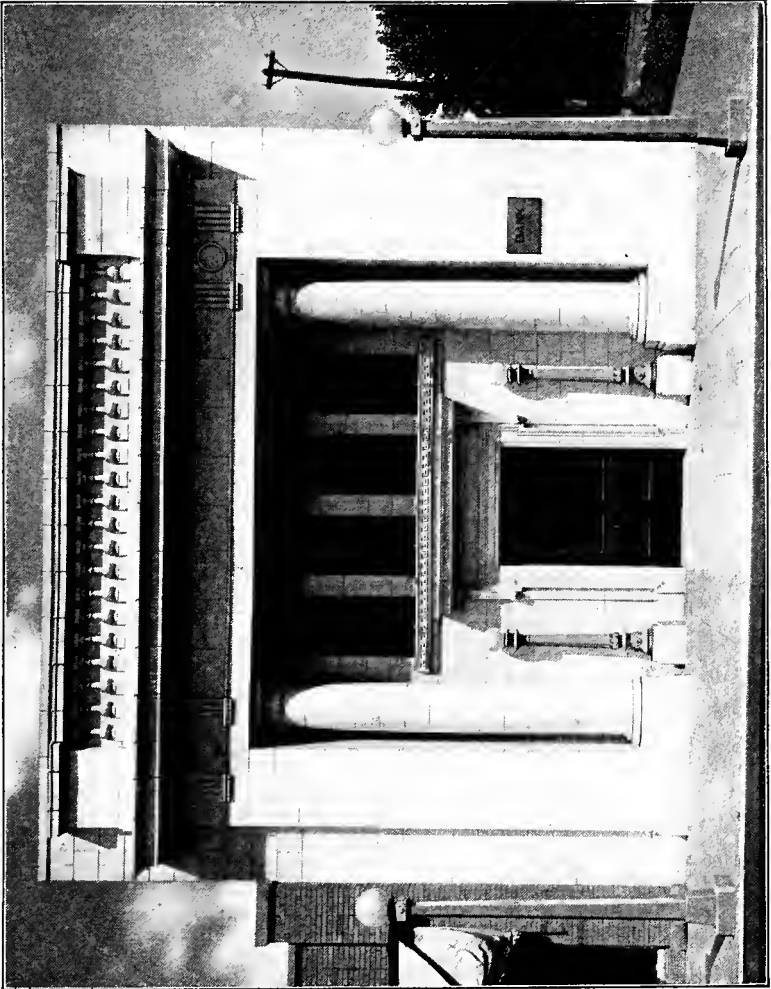

FIG. 3

plain stone-like surfaces which, while excellent, show slight irregularities in this case although they are excellent for terra-cotta work.

---

#### MODELING TERRA COTTA

**16.** Fig. 2 not only shows a proper treatment of terra cotta in plain blocks but illustrates the superior appearance of the terra cotta when richly decorated. It will be noted that there is a considerable repetition of blocks of the same pattern, which would be extremely costly if worked in stone. This example illustrates the possibilities of ornamentation in terra-cotta work in several ways. Shallow modeling, or *low relief* work, is shown in the borders and band courses. Bold modeling, or *high relief*, is illustrated in the wreaths around the circular windows and in the capitals of the polygonal piers. An excellent illustration of figure modeling is shown in the panel of dancing figures above the main entrance. This building is a very good example of the intelligent use of terra cotta.

**17. Repetition of Ornament.**—It is economical in the use of any plastic material, such as clay, to use the same ornament or motif repeatedly in the design, as this tends not only toward harmony of design, which might be too complicated otherwise, but also toward economy in manufacture. As every piece of terra cotta employed in a building must be formed in a mold, the fewer molds that are required the less will be the cost of the work. As the number of pieces needed in even a small structure often runs into the hundreds, and on larger buildings into the thousands, it can be readily seen that a large number of molds greatly increases the expense of manufacture. By repeating patterns, the same plaster mold can be used to cast from 25 to 40 blocks of the same design, which greatly reduces the cost of manufacture.

Designers should, therefore, see to it that they make their designs economical by using a repetition of patterns as much as possible. Thus, a simple running cornice in which each block is like its neighbor on either side, is less expensive to produce than a cornice composed of blocks of several different patterns.



FIG. 4

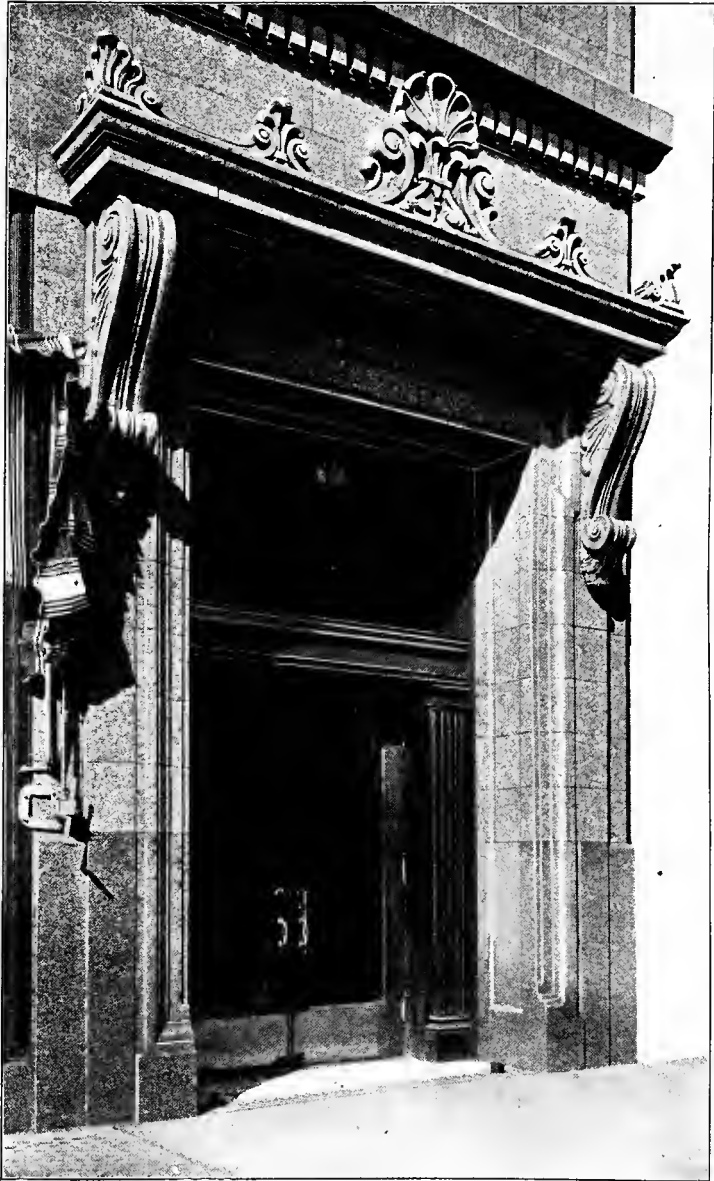
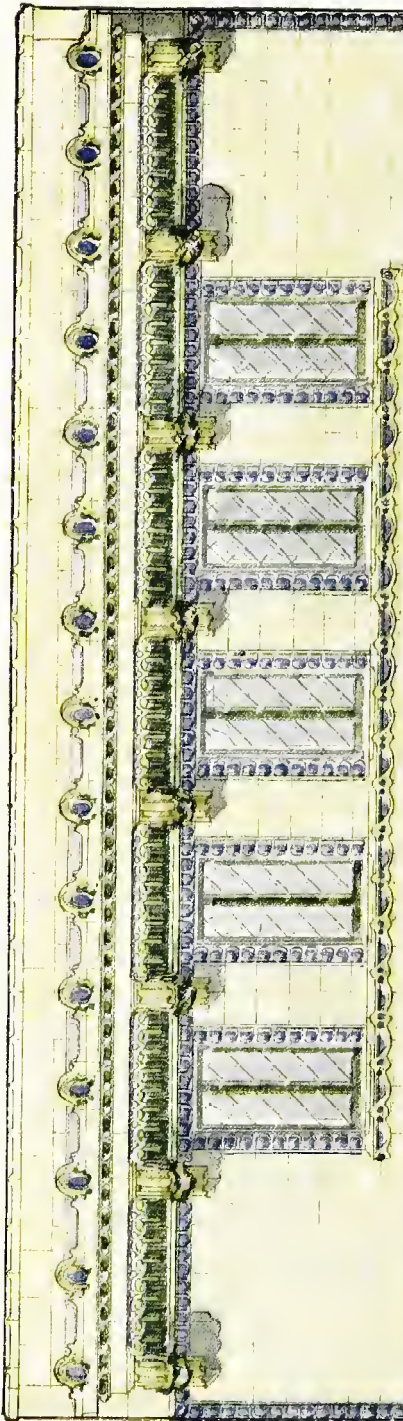

FIG. 5





A large, highly decorative rectangular frame dominates the right side of the page. The frame is filled with intricate patterns, including floral motifs and repeating geometric designs. The text "ELECTRIC HARMONY" is prominently displayed in the center. "ELECTRIC" is written in a simple, sans-serif font at the top, while "HARMONY" is rendered in a large, highly stylized, calligraphic font. Below "HARMONY" is the word "ELECTRIC" in a smaller, similar font. The entire composition is framed by multiple layers of decorative borders, including a wide, patterned outer border and a narrower inner border.

ELECTRIC  
HARMONY  
ELECTRIC



AUTOMATICALLY.  
• DISPLAYED • HERE •

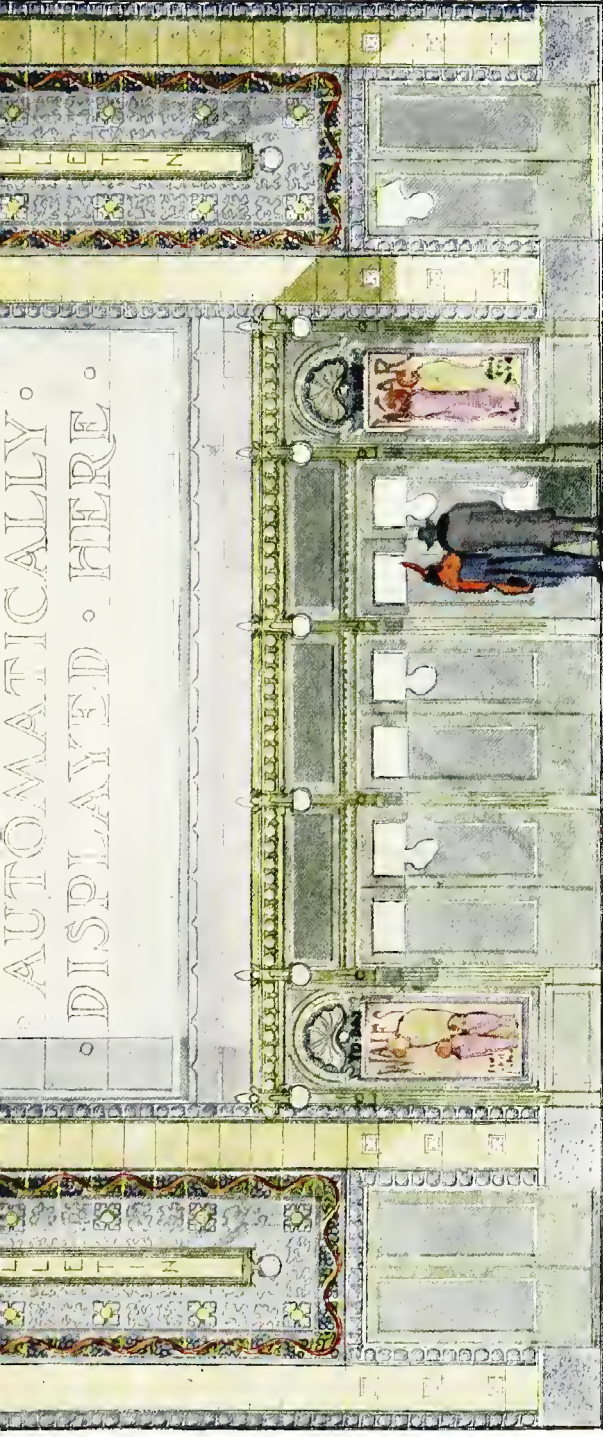

• SUGGESTIVE • DESIGN • IN •  
POLYCHROME • ARCHITECTURAL • TERRA • COTTA •  
• COLORS • CREAM • GRAY • BLUE • GREEN • AND • BROWN •





Lintels and sills for windows, if all of the same pattern, can be produced with a minimum number of molds, but if the lintels on each story vary, or if the several parts of each lintel are different, the number of molds required will be very large.

**18. Modeling in High Relief.**—Terra cotta can be modeled in high relief; that is, the ornament can be made so as to project boldly, as illustrated in Fig. 1, where an eagle in high relief is shown in the panel at the middle of the building above the windows. Bold modeling is also shown in the caps of the terra-cotta piers in Fig. 4, as well as in the ornament over the cornice of the door in Fig. 5. In fact, any projection that can be carved in stone can practically be made in terra cotta.

**19. Limitations in Size of Blocks.**—Stone can be used in large units, its size being determined only by the practicable size in which it can be quarried, worked in machines, shipped, and erected in place. Thus even huge columns of stone may be *monolithic*, or of a single piece of stone. Terra cotta, however, cannot economically be molded in very large units. There are several reasons for this. When undergoing the drying operation in the dry room, shrinkage in large pieces would be so much more than it is in small units that the blocks would tend to warp and crack. After drying, uniform burning in the kilns becomes very much more difficult with large blocks than with small ones and the warping is greatly increased because the heat does not attack all surfaces evenly. The handling and shipping of large blocks requires much more care than when smaller units are employed and there is much more waste from broken blocks. Hence the cost is greatly increased. It is not economical to use blocks greater in size than 27 in. × 24 in. × 36 in. Blocks, especially thin facing or veneering blocks, are made much smaller than this size, as the smaller blocks are usually more economical to manufacture.

**20. Practical Sizes of Blocks.**—As a guide to the architect when designing terra-cotta work, Table I is given to show the most practical sizes of blocks to use for some of the principal parts of a building. In the table, the dimensions given in

the column headed *Depth into Wall* include not only the depth that the block extends into the wall but the amount it projects beyond the face of the wall. Thus, a cornice that extends 10 inches from the wall should extend about the same distance

**TABLE I**  
**PRACTICAL SIZES FOR TERRA-COTTA BLOCKS**

Members	Height Inches	Width Inches	Depth into Wall Inches
Cornices and string-courses.	10 to 24	18 to 24	12 to 24
Walls or panels.....	4 to 24	12 to 24	4 to 18
Sills and lintels.....	4 to 12	14 to 24	4 to 20
Jambs .....	14 to 24	4 to 12	4 to 12
Column drums.....	10 to 16		10 to 20 in Diameter
Columns, Segmental .....	10 to 16		10 to 24 Radius

into the wall, and its *Depth into Wall* dimension would be 20 inches. This applies generally, except when the terra cotta is supported by steel work attached to the frame of a building, when the blocks may extend only 4 inches into the wall.

#### COLORING TERRA COTTA

**21.** Some of the most interesting designs in modern terra cotta are in colors, such as blues, greens, yellows, browns, and reds. Polychrome terra cotta in such designs is largely used for churches, office buildings, store fronts, theaters, and interior decorations; in fact, wherever the design itself is susceptible to the proper use of color. Usually the background of terra cotta is kept in one tone and the modeled portions of the design are in variegated colors. Hence, the latter stand out from the background, and many rich and beautiful effects are obtained.

In Fig. 6 is shown a good example of the use of polychrome terra cotta. In this case it is used for a theater front. The one-tone background consists of plain-surfaced pieces in a cream color and the modeled portions are in blue, green, and brown. The large panel immediately over the entrance to the building

is also formed of plain pieces, in a gray color. This panel is intended for an advertising sign which may be applied to its surface.

---

#### DESIGNING TO RESEMBLE OTHER MATERIALS

**22.** Architectural terra cotta is frequently designed to resemble other materials, such as stones of different kinds, and with various finishes. Granite, with its mottled or speckled coloring, limestone and sandstone with the various toolings of the surfaces, can be closely copied. The cost of the terra cotta is generally less than the cost of the stone. Terra cotta is frequently used in conjunction with stone on the same building, the walls and plain surfaces being finished in the stone, and the ornamental parts, such as cornices and the more richly decorated portions, being formed of terra cotta. When new, the difference in the materials can hardly be distinguished, but after a time the effect of the weather often causes a decided difference in the appearance. In using terra cotta to resemble another material the designer should never lose sight of the limitations of terra cotta.

**23.** Terra cotta that is designed to resemble some other material, such as granite or Bedford limestone, should have the forms of the blocks and the joints as like as possible to those generally employed for the material it is to be like, otherwise the effect it is desired to obtain may be lost.

To follow out this idea, quoins and rustications are sometimes used, arches with keystones may be employed over openings, and often pilasters and panels are used. In a façade intended to resemble cut stonework the greater number of vertical joints required by terra cotta, because of the small size of the blocks, tends to spoil the effect, but a little careful planning will make it possible to put many of the vertical joints in angles where they will not be noticeable.

**24.** In Fig. 5 is shown a building entrance made of terra cotta formed to resemble granite. This entrance is designed with both plain and ornamented parts. The lower members adjoining the doorway, which in the illustration show darker

than the remaining portions, are finished with a glossy surface called *full glaze* and the other portions are finished with a less glossy surface called *mat glaze*. These terms are defined more fully later in this Section. It will be noted in this illustration that the blocks of the upper part of the doorway are small in size, as indicated by the numerous joints, while no joints are visible in the lower members. This is due to the lower members being made in long narrow pieces and the joints being formed vertically in the design, where they are not noticeable. This gives this lower part the appearance of being formed of large pieces of granite, which adds very much to the attractiveness of the design.

**25.** In Fig. 3 is shown a building which has the entire front faced with terra cotta designed to obtain the effect of light-colored stone or white marble. The panel above the cornice, which forms the background for the balusters, is formed of small pieces. By locating the joints behind the balusters, the sizes of the blocks are not apparent, and the effect produced is that of the panel being formed of one large slab.

The columns of this building are formed of small pieces. If they were to be of stone, they would either be in large pieces or in a single piece for the entire shaft of the column. The entire front is formed of pieces of terra cotta that are, as nearly as possible, of the sizes and form that would be used were the material stone, thus carrying out the principle stated in Art. **23**.

**26.** Figs. 7, 8, and 9 all show the use of terra cotta in the construction and decoration of buildings of different types. In Fig. 7 is shown a handsome country residence in which terra cotta is used in place of stone for all the trimmings. The terra cotta is treated in a more ornamental manner than stone would be. The similarity of design in many of the parts is evident in the panels under the windows, over the entrance projection and over the porch. The square panels above the windows over the porch and over the entrance are of two patterns and are cast from two molds. The short pilasters around the top of the wall above the porch and the entrance are all of



FIG. 7

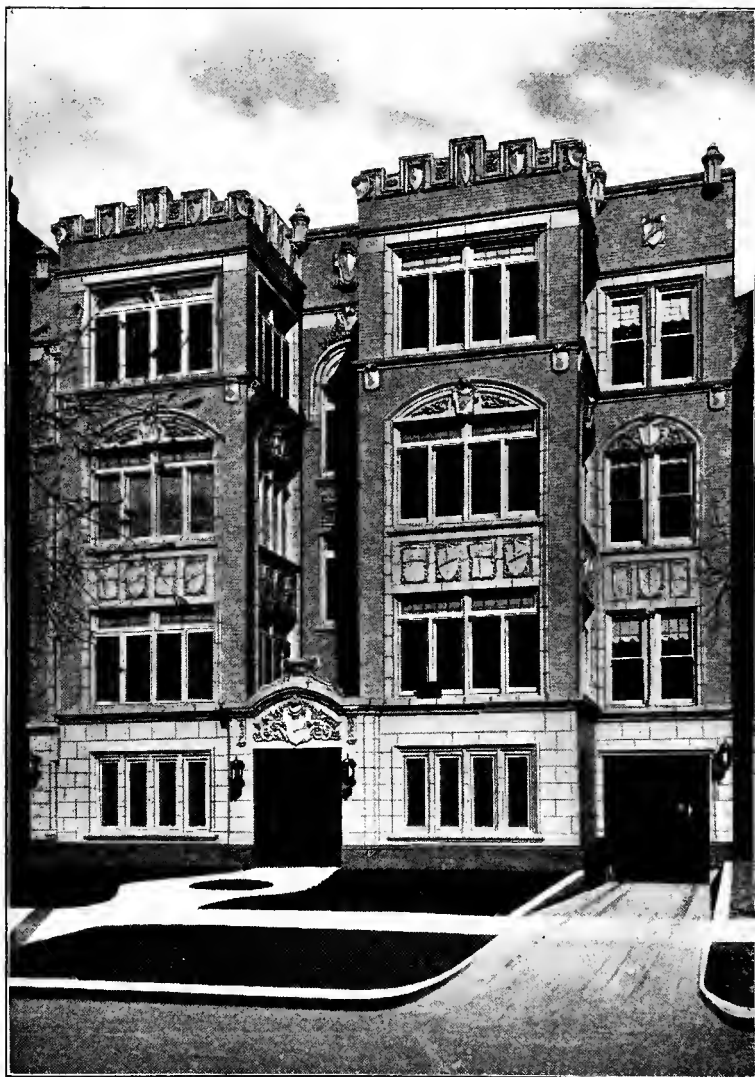

FIG. 8

the same pattern and made with one mold. Thus a very elaborate ornamentation is obtained by the use of three molds from which a great number of similar pieces have been made.

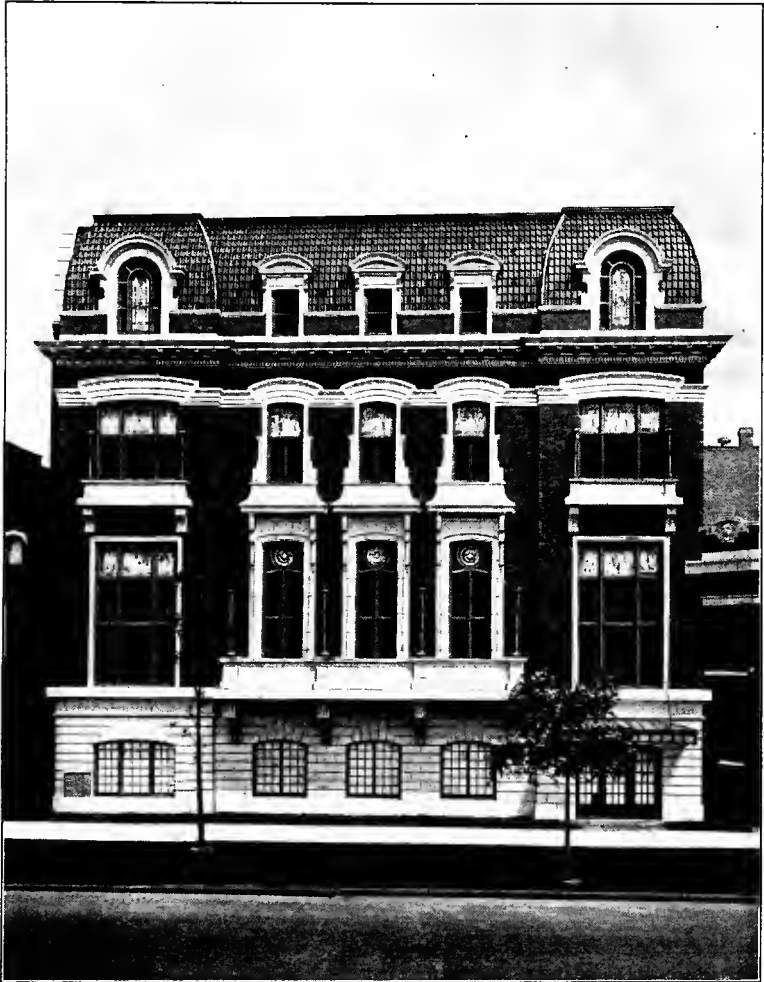

FIG. 9

27. An apartment building is shown in Fig. 8 which illustrates a profuse ornamentation made of terra cotta. The

basement walls are of plain terra cotta resembling stone, while the trimmings of the doors and windows are of molded and ornamented terra cotta used in the same manner as stone is used. The profuseness of the ornament is characteristic of terra cotta.

**28.** The building shown in Fig. 9 has the first-story walls faced with terra cotta designed like rusticated stonework. The balcony at the second-floor level has the design formed with plain blocks, and the brackets that support the balcony are very ornamental. The cornice and the members that surround the windows of the upper stories are all of a design that would be consistent were stone used for this purpose.

**29.** In all of these figures is shown the repeated use of similarly formed blocks both for plain and ornamented parts. Were the material stone, the ornamental parts of the design in many cases would not be attainable on account of the excessive cost in executing the designs in this material.

---

#### STOCK DESIGNS

**30.** Most of the terra cotta used for buildings is especially designed by the architect and is made to order. As the process of manufacture requires from six to eight weeks after the approval of the drawings and details, the architect often finds it desirable to use stock designs that can be obtained quickly and which often suffice for small structures. Most manufacturers keep a stock of molds for certain designs. The use of these stock molds reduces the cost of manufacture materially and also shortens the time required to make the terra cotta.

The designs that the manufacturers keep in stock necessarily consist of the more ordinary forms, for no manufacturer could afford to manufacture and carry a very extensive variety of patterns not knowing what the market demand might be.

For use in brick buildings, manufacturers also carry a line of stock designs for terra-cotta inserts, such as small ornamental blocks and small panels that can be readily inserted in face brickwork to produce an ornamental design.



Architects who contemplate using stock designs of terra cotta can obtain catalogs from manufacturers showing what patterns they carry in stock and giving the colors, finishes, and dimensions. The building in which it is proposed to use such patterns must, of course, be designed to fit the stock form of blocks, for the blocks cannot be cut and must be used in the size and shape in which they are manufactured.

An illustration of the use of stock patterns of terra cotta for a building front is shown in Fig. 1. The members which form each ornamental band or belt-course, also the panels of the pilasters, are small units of the same design, and plain pieces of terra cotta are used in various sizes to secure the required spaces for the ornamental parts. The coping is formed of both plain and ornamented pieces and is raised at intervals by means of special pieces to suit the requirements of the large ornaments that are placed over the second-story windows.

The panels over the first-story entrances, which contain the lettering, require to be made to order.

---

#### STRENGTH AND WEIGHT OF TERRA COTTA

**31.** Well-burned terra cotta will stand a compression test of 5,000 pounds per square inch, which is ample for any loads that are likely to be placed upon it.

The **weight** of hollow terra-cotta blocks, unfilled, is from 65 to 85 pounds per cubic foot. When filled with brick they weigh from 120 to 130 pounds per cubic foot, and when filled with concrete, from 130 to 140 pounds.

---

#### ARCHITECT'S DRAWINGS

**32.** The architect's drawings are made to show the design of the building which the architect has conceived and which he wishes to erect. They also are made to express the requirements of the design in such a manner that the contractor and the workmen may comprehend the intentions of the architect, provide the necessary materials and labor, and erect a structure of the form and design required.

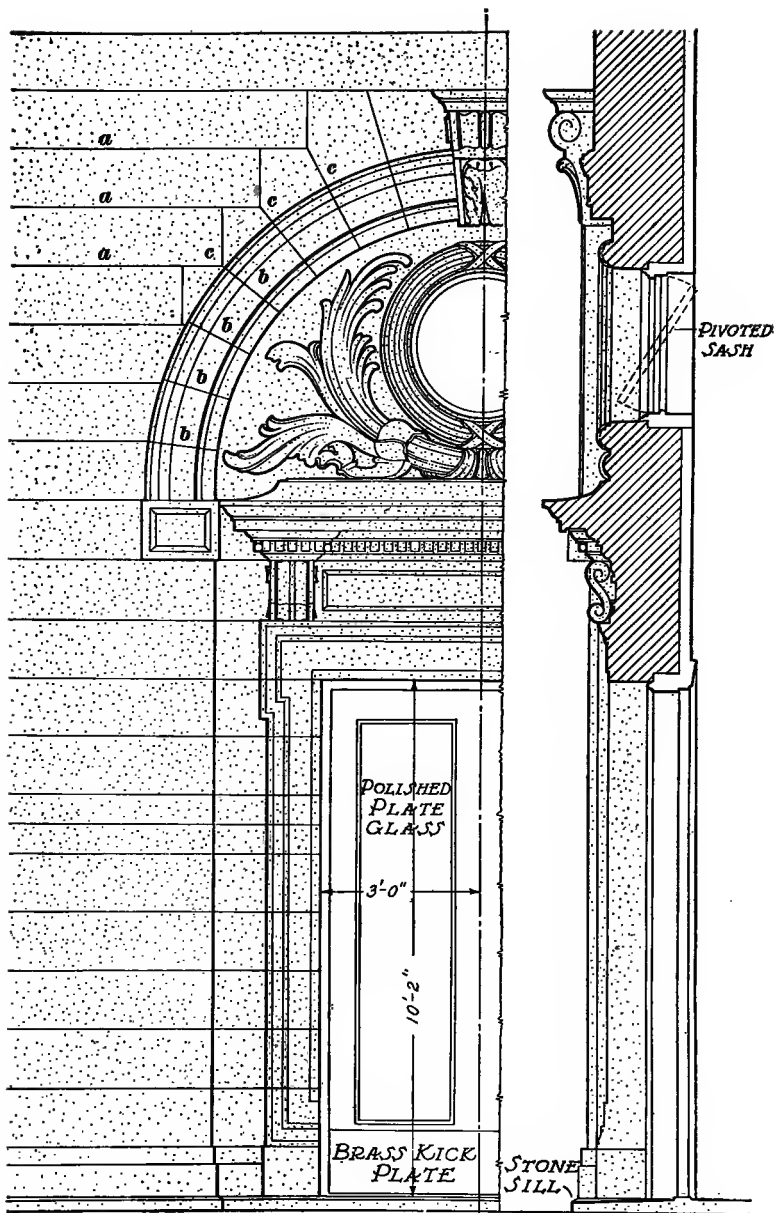

(a) FIG. 10

(b)

The architect's original working drawings usually consist of plans, elevations, and sections, drawn to a scale of  $\frac{1}{4}$  inch or  $\frac{1}{8}$  inch to the foot. These should clearly indicate the various materials that are to be used and the general form of construction. If terra cotta is to be used, the drawings should show the parts that are intended to be plain, those that are to be ornamented, and the general supports on which the terra cotta is to rest. These drawings will be sufficient for the manufacturer to bid from.

After the contract for the terra cotta has been awarded, the architect should prepare large-scale drawings that will show fully the forms of the terra-cotta parts and will give suggestions as to the jointing. He may if he desires prepare full-size details that will show the contour of all moldings, as well as the nature of the ornamental parts. These drawings are then given to the manufacturer to follow when making his shop drawings. It is customary, however, for the architect to require the terra cotta manufacturer to make the full sizes in which case they are drawn to shrinkage scale.

**33. Example of an Architect's Drawing.**—An example of an architect's drawing for an entrance and wall finished in terra cotta is shown in Fig. 10. Such a drawing is generally made to a scale of  $\frac{3}{4}$  inch=1 foot. An elevation of part of the entrance is shown in (*a*) and a section through the entrance in (*b*). At *a* in (*a*) are shown the architect's suggestions for the horizontal jointing of the wall blocks; at *b*, the jointing for the arch over the entrance; and at *c*, the jointing for the terra cotta in the wall where it intersects with the arch. The jointing of the ornamental panel over the entrance is not shown in this drawing, as it is left to the manufacturer to determine what forms of blocks he can cast that will conceal the joints as much as possible.

### MANUFACTURER'S DRAWINGS

**34.** The architect's drawings are sent to the manufacturer of the terra cotta, who copies them and adds details of jointing and of anchoring the blocks to the constructional parts of the building. These drawings are then submitted to the architect for approval. The architect makes any changes and corrections on them that his judgment may dictate, marks them *Approved*, and returns them to the manufacturer. The manufacturer then proceeds to make further detail drawings which are drawn to what is called the *shrinkage scale* as will be described presently.

**35. Example of a Manufacturer's Drawing.**—In Fig. 11 is shown the manufacturer's drawing of the same entrance that was shown in Fig. 10. It will be noted that the horizontal joints of the plain wall, the radiating joints of the arch, and the joints *c* between the wall and the arch, as shown in Fig. 10 (*a*), have been retained. Vertical joints *d*, Fig. 11 (*a*), however, have been added to show the length of the wall blocks. The joints *e* and *f* are suggested for the ornament over the entrance. These joints are made to follow the form of the ornament as far as possible so that they may be partly concealed.

In Fig. 11 (*b*) is shown the contour of the terra-cotta blocks that occur in this section, the depths that these blocks set into the wall, and the manner in which they are secured or supported. All of the terra cotta over the doorway, also the masonry with which it is backed up, is supported by the steel members shown at *a* and *b*. Anchors *c* are used to tie the projecting blocks to the body of the wall. The blocks *d* are designed to form a self-sustaining arch, as shown at *g* in (*a*). To prevent any settlement of these blocks or the opening of the joints between them, they are usually anchored to the steel members by means of small suspension rods, shown at *f* in (*b*). The blocks *e* in (*b*) are likewise suspended from the steel member *a*. The diagonal lines show the backing which consists of brickwork.



In addition to the general dimensions, the manufacturer's drawings usually indicate the sizes of the blocks, as in Fig. 11. When these scale drawings have been approved by the architect, the manufacturer proceeds to lay out the details of the various blocks at the *shrinkage* scale, which is a scale that makes allowance for the shrinkage that invariably occurs when burning the blocks.

**36. Shrinkage of Terra Cotta.**—Since terra cotta shrinks in manufacture about 1 inch per foot, the full-size shop drawings are drawn larger than the required size of the completed blocks. Thus, when it is desired to make a block

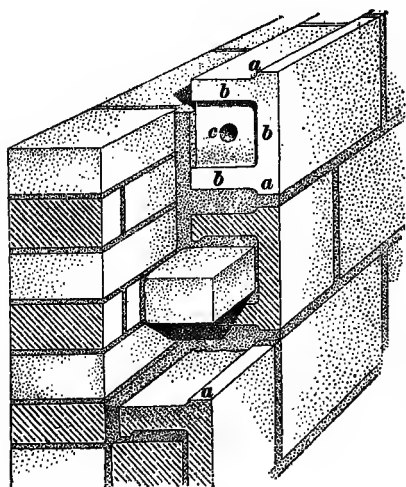

FIG. 12

12 inches long, the shop drawings show it 13 inches long. The plaster model and resulting plaster cast will be 13 instead of 12 inches long and the pressed-clay block will be 13 instead of 12 inches long. After the block has been dried and burned, however, it will be found to have shrunk to about 12 inches, or the size required.

Shrinkage can be estimated quite accurately, but it sometimes varies as much as  $\frac{1}{8}$  to  $\frac{1}{4}$  inch per

foot. Thus, a block estimated to shrink to an even 12 inches might prove to be when burned,  $\frac{1}{4}$  to  $\frac{1}{8}$  of an inch longer or shorter when it comes from the kiln. For this reason terra-cotta blocks are cast with a lug at each edge, which can be cut or rubbed down by machinery to make the block the exact size required.

The form of lug that is usually cast on the upper and the lower edges of the blocks is shown at *a* in Fig. 12. At the

ends of the blocks a similar form of lug is cast, as shown at *b*, and this projects beyond the face of the shell of the block *c*.

Variation in shrinkage is affected by the moisture or the stiffness of the clay when pressed into the mold, and by the dryness of the plaster mold in which the clay is pressed, since a dry mold will absorb more moisture from the clay than a moist mold. It is also modified by the exactness with which the clay ingredients are mixed, by the atmospheric conditions while the block is drying, and by the varying degrees of heat in different parts of the same kiln.

**37. Design of Steel Supports, Anchors, Etc.**—All the loose steel and iron necessary to attach, or anchor, the terra cotta to the building proper, must be designed by the terra-cotta manufacturer and shown on the drawings. He should also provide a schedule, or list, of all this iron and steel with his final drawings. Sometimes the contract requires that the terra-cotta manufacturer provide all this steel work, but as a rule the steel contractor provides it according to the schedule and drawings prepared by the terra-cotta manufacturer.

**38. Final Approval of Manufacturer's Drawings.** When the manufacturer's shop drawings are completed, they should be carefully reviewed by the architect to see that the designs conform in every way with his details from which the shop drawings were made. These shop drawings should show the full sizes of all moldings, the general construction of the terra cotta, and the proposed methods of anchoring the blocks to the building. The jointing also should be indicated.

It may be necessary for the shop drawings to be changed a number of times before they meet with the approval of the architect in all particulars. He should carefully review the final drawings and approve them before they are handed back to the manufacturers.

### MODELING

**39.** When the architect has approved the drawings and has marked them accordingly, the work of modeling the various blocks is then begun. The plain work in which no molding or ornament appears is given to the average workman.<sup>o</sup> Those parts of the work that consist of ornamented moldings, panels, cornices, brackets, and sculptural details are given to modelers of ability, whose duty it is to interpret the drawings in an artistic manner. Large manufacturers of terra cotta appreciate the importance of good models and usually employ only the most skilful men for this branch of the work. The results are that terra-cotta work can be used where fine artistic work is required and that this material is not considered as a mere substitute for stone, but as a material capable of the finest artistic expression when used in accordance with its peculiar characteristics.

**40. Models.**—Models are made for all ornamental pieces of terra cotta. These models are made of plaster of Paris, which forms the background, and moldings and the ornament are modeled in clay on the plaster backing. They are always made according to the shrinkage scale, that is, each 13 inches represents 12 inches in the finished product. The models of large pieces of ornament, panels, etc. are made without joints. The joints are put in later after the model has been finished and is ready to be cut up into blocks of convenient size.

**41. Inspection by the Architect.**—When the models are completed according to the drawings, the architect is notified; and if it is not convenient for him to call at the works and inspect the models, photographs are taken, a rule being laid alongside of each model to show the size and scale, and these photographs sent to the architect for inspection and approval. When this method is followed, two copies of the photograph of each model are usually sent to the architect, who indicates the suggested corrections and changes on each copy, returning one copy to the manufacturer and retaining the other copy for



the purpose of comparison with a later photograph which is sent him after his suggestions have been incorporated in the model. If the later photograph indicates that the model is satisfactory, he notifies the manufacturer accordingly.

If the architect can visit the plant to inspect the models for the terra cotta, it will prove more satisfactory than to attempt to judge and approve the models from photographs, as he can better appreciate the form, size, and details of his design by seeing them executed at full size in clay. He can also suggest changes that he may wish to make and have these incorporated in the clay and thus secure the desired effect. This done, he can approve the model and work can progress without further delay.

**42. Cutting Up the Model.**—After the model has been approved, it is cut into pieces of the right size from which to make the molds. The manufacturer usually determines the form and size of blocks that he considers best adapted to the design and to secure the best results in the burning. The jointing is indicated on the model or on the photograph that is submitted to the architect for his approval. Thus, an ornamental panel that may be 8 or 10 feet in diameter and in a single piece when inspected by the architect, might afterwards be cut into pieces not greater than 18 by 24 inches in size. The finished terra cotta comprising this panel will be cast in small blocks and combined to form the completed panel, all joints being filled with mortar.

If the joints are to be inconspicuous, the fact should be made known to the manufacturer before the model is cut into pieces, so that the joints may be cut around the ornaments, or that other steps may be taken to prevent the joints from showing when the different panels are built up.

### MOLDS

**43. Plaster Molds.**—To reproduce in terra cotta the design that has been formed in the model, it is necessary to make a plaster-of-Paris mold of the model and use it as a mold into which the plastic clay is placed.

The plaster-of-Paris mold requires to be strongly constructed to withstand the pressure of the moist clay. It is usually reinforced with  $\frac{1}{4}$ -inch square steel rods and the sides are bound with steel strap irons.

After the clay block has been formed, it is allowed to remain in the mold a sufficient length of time to dry properly before being removed. When it is removed it has the same contour and ornament as the original clay or plaster model.

---

## MANUFACTURE OF TERRA COTTA

---

### MATERIALS

**44.** Architectural terra cotta is made in somewhat the same manner as hollow tile or brick; that is, it is a material molded in clay and afterwards burned in a kiln. The manufacture of architectural terra cotta, however, requires a much more refined process than the manufacture of brick or hollow tile, the method is also more complicated, and the product must be worked with a larger amount of skilled labor.

**45. Clay.**—Clay used for architectural terra cotta must be of a higher grade than that used for brick. Terra cotta that is to be glazed requires clay free from impurities that tend to fuse in the kiln, as this action will cause the glaze to pop, making unsightly stains, crazing, or fractures.

**46. Shale.**—Shale is very largely used for the manufacture of terra cotta. Clay and shale from different parts of the country acquire different colors when burnt in the kiln, some coming out with a light yellowish tint, some a deeper shade of

salmon, others light or dark buff, while some are a strong brick red.

As terra cotta is a material that may be artificially glazed, the finished color does not depend upon the natural color of the body that is secured by the burning.

**47. Location of Plant.**—A plant for the manufacture of terra cotta is rarely located close to the source of supply of the required clay, for usually it is more desirable to keep the factory near the supply of labor and ship the clay such distance as is necessary. Furthermore, the bank of clay sometimes runs out, or the clay changes in character to such an extent that it is not suitable for the quality of terra cotta desired.

**48. Treatment of the Clay.**—The clay is received at the factory and is allowed to weather, which causes it to crumble and pulverize. It is then mixed with about 30 per cent. of burned clay that has been ground fine. The mixture is then pulverized by special machinery, and afterwards mixed with water and treated in a pug mill until it becomes a smooth soft mass of material capable of being molded or cast. It can be kept in that state until required for use.

**49. Manufacture of Blocks.**—The prepared clay is taken to the pressing room, where it is pressed into the plaster-of-Paris molds and then artificially dried with hot air, a process that usually requires from 2 to 3 hours. By this time the material has dried and stiffened sufficiently so that the blocks can be taken from the molds and handled without injury.

The raw blocks are then finished; that is, the seams are removed and the ornament is cleaned out.

If the blocks are to be finished with a smooth glazed surface, they are troweled smooth, and in this process the pores of the clay become closed and the finished surfaces of the material are made smooth and firm to receive the glaze.

Next, the blocks are placed in dryers, where they are subjected to hot air. This expels all moisture from the blocks, gradually making them bone dry. This drying takes about 48 hours.

The blocks then go to the glazers, where the exterior, or visible, surfaces are coated with a color or glaze as desired. They are then ready for burning and are taken to the kiln and subjected to a heat of from 2,000 to 2,300 degrees F. The burning process usually lasts from 12 to 14 days.

All terra-cotta blocks are made hollow, and the outside shell, which is usually 1 inch thick, is stiffened with webs, which are also about 1 inch thick. The number, size, and thickness of the webs and the thickness of the shell are determined by the size of the blocks, large blocks requiring a thicker shell and more webs than small ones. The voids are placed about 6 inches on centers.

Webs and shells of blocks have holes cast in them to facilitate anchoring them to the wall or structure. These holes also facilitate the handling of the blocks, as it is possible to pass the fingers through the holes when carrying the blocks. At the same time holes make the blocks lighter in weight and furnish a better bond for the mortar, which can flow into them and form a key.

---

#### FINISHES AND COLORS

**50.** Owing to the fact that terra cotta is formed of plastic clay, any finish or texture of the surface may be obtained by treating the block when it is being formed. Like pottery and faience, the clay may also be tinted, and any color, combination or blend of colors may be secured when it is burned in a kiln.

**51. Texture.**—The texture of the material is obtained in three ways: (1) By reproducing the sample of the surface to be matched, by modeling it in clay in the face of the plaster model before it is molded. This method is used to reproduce picked, stippled, crandaled and bush-hammered surfaces; (2) tooled surfaces are cut in the mold by special tools; (3) smooth-, light-, and rough-drag surfaces are obtained with finishing tools after the blocks have been removed from the mold. These textures may imitate rough, smooth, tooled, or polished stonework. To produce imitation granite, limestone, or sandstone, the manufacturer uses for his model a block of

real stone and can produce an accurate imitation, either of polished or dull finish or of the texture given to the stone by means of tools or hand modeling.

**52. Coating or Spotting of Terra Cotta.**—In terra cotta the original mixture of clay has little influence on the final color, which is obtained by tints applied in the form of slips, or glazes. These glazes produce the plain colors such as are seen in polychrome terra cotta. The mottled finishes are obtained by spotting the surface or the slip with various colors to produce effects such as the mottled colors of granite or other stones of a spotted nature. Thus, by combining spotting and texture, endless variations are possible.

**53. Glazing.**—The final process of treating terra cotta before it is burned is known as *slipping* or *spraying*.

Terra-cotta plants usually maintain a laboratory where the various clays, colors, and glazes are experimented with. Mineral colors are used in coloring and glazing and these materials do not look the same after they are baked as when they are applied to the unburned block. The burning produces a chemical change in the colors. Hence when seeking new shades of color the chemist applies the coloring material to a small briquette of terra cotta, burns it, and notes the results. The formulas for all mixtures of color and glaze are carefully preserved, so that given colors can be reproduced at any time. When it is decided to use a certain color or glaze, the coloring materials are carefully weighed and mixed together in exact proportions with the greatest care according to the formula for that color. The colors are mixed with water and applied to the blocks before burning, by means of a spray from an air brush. With some glazes or where a full gloss is desired on the surface, it is sometimes necessary to put on an *under glaze* as a first coat, and apply the final glaze over this.

**54.** These glazes are used to furnish the colors required by the design and at the same time they make the surface of the terra cotta more or less impervious to water. There are four finishes that are usually specified by architects. These are

the *standard*, or *unglazed*, which is not wholly impervious to moisture; the *vitreous*, which is impervious to moisture; the *mat-glazed*, or *mat-enameled*, which is glazed, has a dull finish, and is impervious; and *full-glazed*, or *enameled*, which is impervious and has a glossy finish.

In addition to these standard finishes, terra cotta, as has been stated, can be treated in any desired shade or color, to form polychrome terra cotta. Different parts of the block may be treated with different colors. If not otherwise specified, most manufacturers base their estimates on the *standard color*, which is that of light Indiana limestone, and is unglazed.

**55.** In **standard** finish, the terra-cotta blocks, after drying and before burning, are covered with a coating of clay *slip*, applied with an air brush. This produces a dull finish which is not "glassy" and the terra cotta so treated is not impervious to moisture, but has about the texture of good hard burned face brick.

In the **vitreous** finish, the glaze, or slip, is prepared with more of a glass-like quality by the addition of suitable minerals. This is also put on with an air brush, and two coats may be necessary to obtain the color desired, the first coat being a slip of one color to fill the pores of the blocks and the second coat a glaze of the same or another tint, depending upon the effect desired.

The glaze used in the vitreous finish vitrifies when burned; consequently, terra cotta with this finish is impervious to moisture. This glaze is, however, very thin.

**Mat-glazed**, or **mat-enameled**, finish, as its name suggests, is a dull glazed finish in which the glaze employed is of a glass-like nature but the finished blocks are not glossy. The glaze is heavier than that used on semiglazed terra cotta. The surface of mat-glazed terra-cotta blocks is impervious, hence they are excellent for outside work where the weathering qualities of the blocks must be considered. Mat-glazed finish can be washed down as readily as full-glazed.

**Full-glazed** terra-cotta blocks, as their name implies, are coated with what is practically liquid glass, which when burn-

ing fuses and leaves a glossy finish excellent for its weathering qualities and because it can so readily be washed clean. This finish is, however, expensive and not frequently used.

---

#### FITTING AND NUMBERING THE BLOCKS

**56. Fitting the Blocks.**—After the terra-cotta blocks have been burned they are allowed to remain in the kiln until they cool. They are then taken to the storage shed and the pieces are laid out on a floor in the order in which they will appear in the finished building. The pieces are carefully fitted together to see that they are the exact size and shape called for by the shop drawings. Any pieces that are imperfect are sorted out and new pieces made to take their places.

When the blocks are laid out, every block in a string-course or cornice, lintel, or jamb is carefully placed to see that the length of the course is just right as shown on the plans. Thus, a cornice composed of many blocks of terra cotta is like one composed of cut stone, each piece of which must be carefully made from the architect's drawings so that when they are placed together and the proper allowance made for the mortar joints, the total length will meet the requirements of the drawings.

Some of the blocks may require to be cut down slightly, and to accomplish this result the lugs on either end, which are provided for this purpose, are cut with a chisel; or if the excess is very slight, as is usually the case, one or both ends of the blocks are rubbed down by machinery.

It is the usual practice to rub or cut down all adjoining edges of blocks whether any great excess of length has to be removed or not, as this treatment secures a true and square edge at the joints, consequently the lugs are formed sufficiently long to permit of this rubbing without cutting into the shell of the block.

To insure the proper inspection and jointing of the blocks by the manufacturer at the plant, however, the architect should incorporate in his specifications definite requirements regarding this work. This is desirable in order that imperfect pieces may

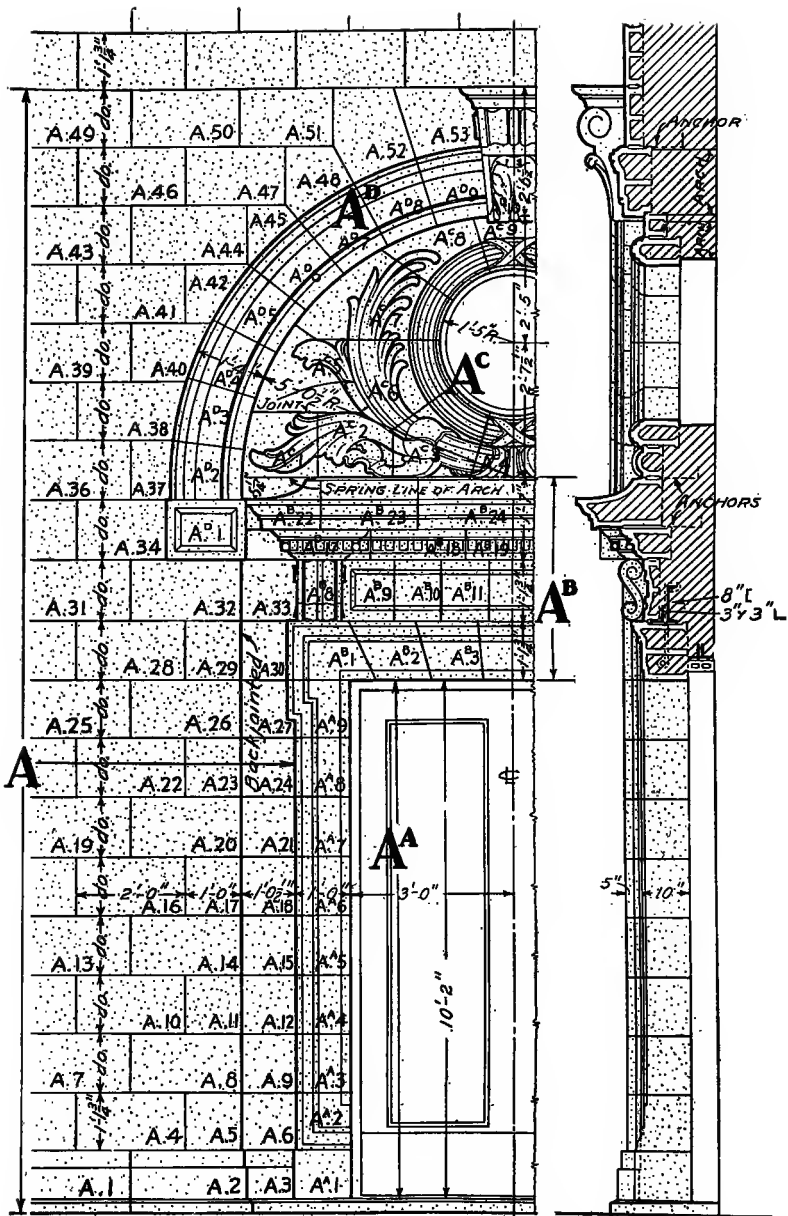

FIG. 13



be replaced as soon as possible instead of waiting for errors to be discovered at the building, when the work will be delayed while new pieces are being made.

**57. Numbering the Blocks.**—After the blocks have been fitted together at the factory, each piece is marked on the back with black paint. A diagram is then made which shows each block of terra cotta, and this is marked with letters and numbers to correspond with those placed on the blocks. This diagram is sent with the shipment of terra cotta to the building, so that the workmen can readily assemble the blocks in precisely the same order in which they were fitted at the factory.

This assembling diagram, sometimes called the *setting plan*, usually consists of a blueprint of the manufacturer's scale drawing on which is shown every block and all the joints. Fig. 13 is an illustration of such a plan for the terra-cotta entrance shown in Fig. 11. The terra cotta of each story is usually indicated by a large capital letter, *A* representing the first story and *B* the second story, etc. Each special feature is represented by a smaller capital letter, that, in connection with the larger capital letter and a number, is used in marking each block.

Thus, the plain wall facing for the first-story wall is labeled *A*, as indicated in Fig. 13, and each block has a special number. The arch over the entrance is marked *A<sup>D</sup>*. All the pieces of terra cotta forming this arch are marked *A<sup>D</sup>* and a special number, as *A<sup>D</sup>.1*, *A<sup>D</sup>.2*, etc. This system of marking absolutely identifies each block and, having the setting plan and the number on each block, the contractor should have no uncertainty in picking out the blocks.

**58.** Another system of marking the setting plan and the blocks is illustrated in Fig. 14 which has some advantages in the way of simplicity. The different features of the building are lettered *A*, *B*, etc., but by this method all similar blocks have the same number. Thus, all the wall blocks are marked *A* and all the blocks shown marked *A 5* are of the same size and pattern, and all marked *A 4* are of the same size and pattern.



Any block marked *A 4* can be taken from the pile and placed in any position marked *A 4* in the setting plan. In the system shown in Fig. 13 blocks *A 4*, *A 10*, *A 16*, *A 22*, etc. are all of the same pattern and are interchangeable, but they must be carefully sought and laid in the rotation indicated on the plan. Thus the mechanic must look after fifty or more numbers instead of eight or ten.

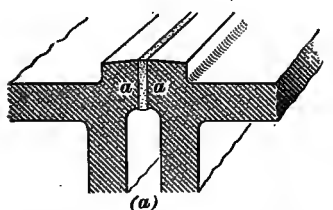

(a)

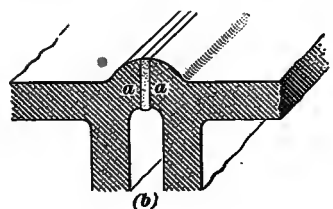

(b)

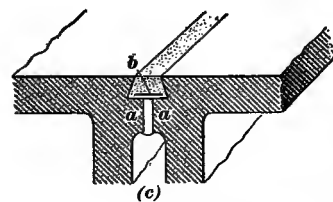

(c)

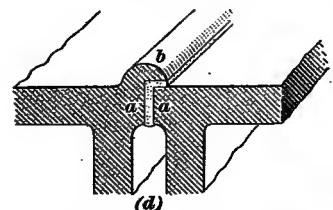

(d)

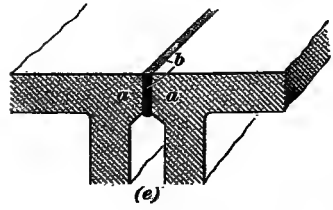

(e)

FIG. 15

the block has not shrunk to the degree calculated upon or is so

#### DETAILS OF CONSTRUCTION

**59.** The process of designing terra cotta, of making the various drawings required, of modeling, and of the manufacture of the blocks having been described, some of the details of construction, which are peculiar to this material, will next be considered.

**60. Forms of Joints.** The joints considered in this article are the abutting or connecting surfaces of the various blocks, and not the spaces filled with mortar between the blocks. The character of these joints is peculiar to terra cotta. The straight joint is illustrated in Fig. 12. These joints must be made so as to allow of grinding or chiseling off the joints when

warped that trimming of the joints is necessary to make the face of the block true. As it would be difficult and expensive to grind the entire surface of the block, the joints are designed to be formed by the edges of the block, which are slightly raised so that any fitting that may be required may be done on the narrow surfaces *a*, *b*. The depressed spaces behind these narrow edges are filled with mortar.

**61.** Another characteristic form of joint is that required on the top surfaces of cornices, copings, string-courses, window

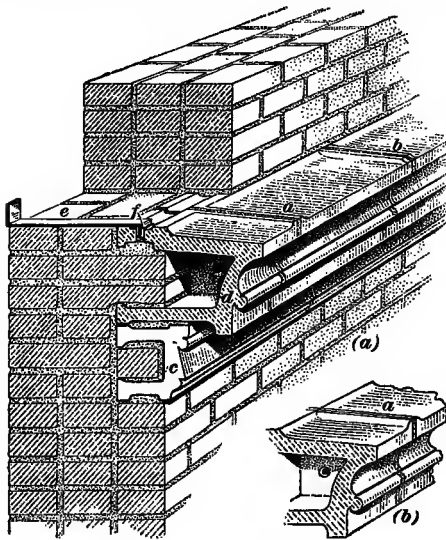

FIG. 16

sills, or any other surface upon which rain or snow may fall. These joints are illustrated in Fig. 15 (*a*), (*b*), (*c*), (*d*), and (*e*), which show five customary forms of such joints.

In (*a*) is a *rectangular raised joint* and in (*b*) a *segmental raised joint*. The raised portions prevent water flowing into the joint. Both these forms are extensively used, and, where the opening

between the blocks is well filled with mortar, prove very satisfactory.

In (*c*) is shown a *recessed, or dovetailed, form of joint*. A piece of sheet metal *b* is usually inserted to form a base on which the mortar may rest and to prevent the mortar passing through the smaller opening below. The mortar of these joints is finished flush with the surface of the block.

In (*d*) is shown the *roll joint, or covered joint*. This form of joint affords better protection to the mortar joint between

the blocks than any of the other forms described. The roll *b* is, however, often broken or injured in handling or shipping, or is forced off by the action of frost which necessitates repairs that always prove unsightly. The use of this style of joint is therefore not to be recommended.

In (*e*) is shown a *butt joint*, such as used in stone and marble work and is highly recommended for use in terra-cotta con-

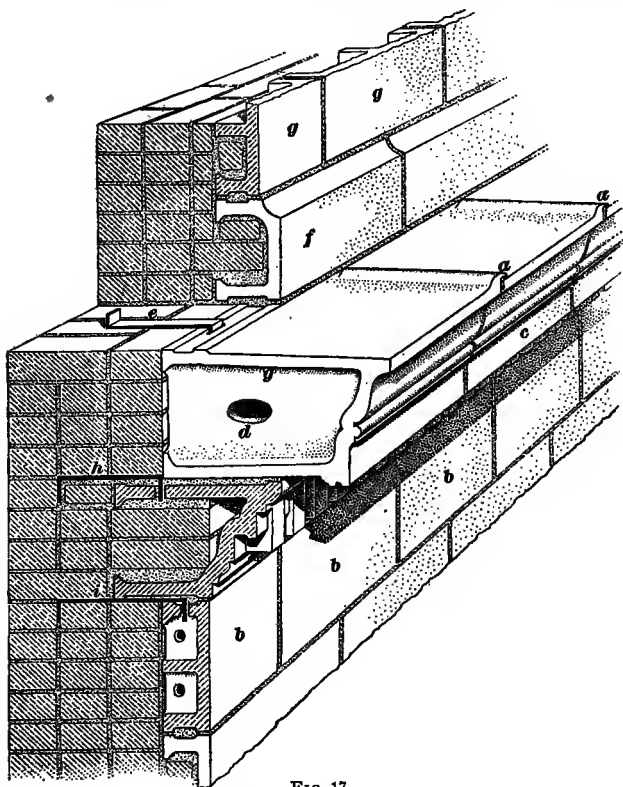

FIG. 17

struction. The edges of this joint are not easily marred by handling and the joint can be calked with mastic *b*, without necessarily breaking the edges. This style of joint is to be preferred to the others, as it presents no thin projecting parts that can be easily broken off.

**62. Examples of Joints.**—In Fig. 16 (*a*) is shown a terra-cotta belt-course that is built into a brick wall. The upper part of this course has blocks that are formed with joints of the raised rectangular shape. At *a* is shown one of these joints finished straight with the edge of the block, while at *b* the joint at the edge is finished with a *cove*. By means of this form the

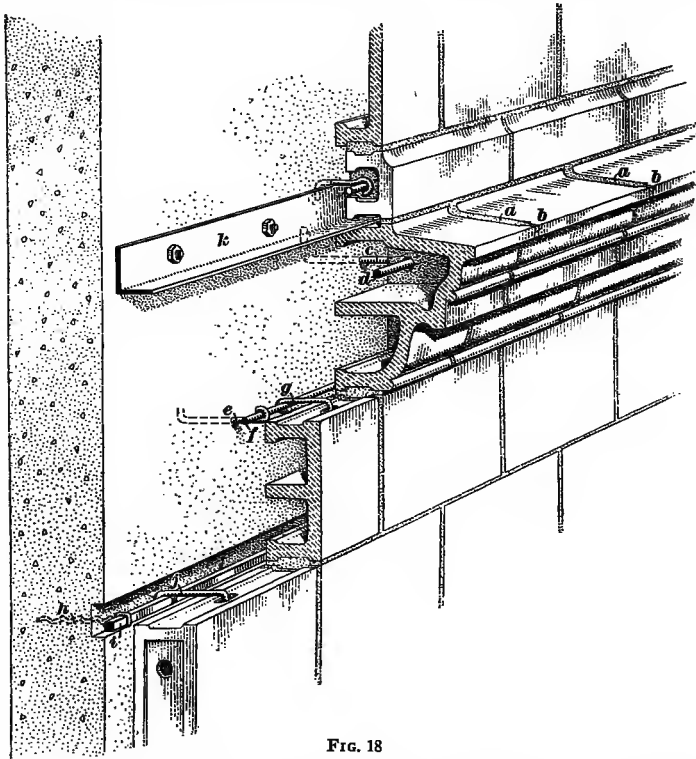

FIG. 18

joint projecting above the block is not apparent from below. At *a* in (*b*) is shown a segmental raised joint.

In Fig. 17 is shown a wall faced with terra cotta, and a projecting course also formed of the same material. The blocks of the projecting course have a roll, or covered, joint *a*. These joints, as well as the segmental raised joints, may terminate at the edge of the course with a cove as previously described.

In Fig. 18 are shown joints *a* of the dovetailed form. In this illustration it will be noted that at the front edge of the block, as shown at *b*, the joint is contracted to the same width as the regular vertical joint below.

**63. Concealed Joints.**—As the sizes of the blocks used in terra-cotta work are necessarily small, there will be a considerable number of joints. It is therefore desirable to conceal these joints when it is possible. This can often be done with vertical joints, which can be concealed at panel moldings, pilasters, window and door trims, etc. In concealing these joints, one block is rabbetted out so as to project in front of another piece, thus concealing the joint. These joints are considered as concealed as they are not visible to a person looking at the building casually.

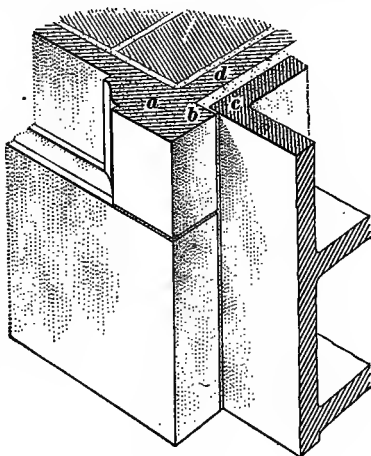

FIG. 19

In Fig. 19 is shown a concealed vertical joint between the blocks which form a paneled pilaster and the wall of a building. The block *a* is recessed on the back at *b* and the end of the block *c* is placed in this recess and thus made to fit closely. This method of treating joints is sometimes called *back-jointing*.

Additional illustrations of concealed vertical joints appear later on in this Section in connection with the description of Columns and Pilasters.

**64. Reglets.**—Where a wall or a wall facing of terra cotta adjoins a roof construction, it is often necessary to place flashing and cap flashing against the terra cotta. The exact position of the roof should be shown on the plans and if it is found that the horizontal joints between the terra-cotta blocks will not serve to receive the upper edge of the cap flashing,

grooves, called *reglets*, should be formed in the terra-cotta blocks for this purpose.

In Fig. 20 is shown a parapet wall formed of the terra-cotta blocks *a* and coped with the blocks *b*. At *c* is shown a *reglet* that has been formed in the blocks adjoining the roof, and at *d*, is shown the edge of the cap flashing *e* placed in this reglet. After the cap flashing has been set into the reglet it is usually

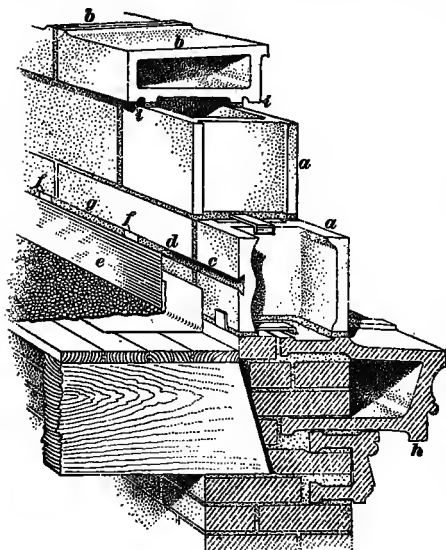

FIG. 20

secured by means of lead wedges *f* placed at intervals, and the remaining part of the reglet is filled with roofer's cement, as at *g*, to insure a waterproof joint.

### 65. D r i p s .

Terra-cotta sills, string-courses, cornices and copings that project beyond the face of the wall below should have a member formed on the lower part, called a *drip*, that will cause the water to fall free from the wall and not run

directly down the wall. In Fig. 20 is shown a projecting cornice with a drip at *h*, and a coping with drips at *i*.

**66. Securing Terra Cotta to the Structure.**—Since terra cotta is generally a veneer, it must be fastened to and supported by the general structure in some way. There are two methods of fastening terra cotta to the supporting structure: First, by bonding the blocks into the wall; and second, by fastening it to the structure by means of steel work in the form of ties, anchors, channels, angles, etc. The forms of steel used in this work are shown in connection with the various details or forms of terra-cotta work next to be considered.



**67. Wall Facings.**—In buildings of brick or stone masonry faced with terra cotta, the facing blocks are laid up like brick or stone, each course being embedded in mortar on the course below. Each piece is anchored with galvanized or painted iron wall ties embedded in the main wall or anchored to the steel frame to hold the terra cotta securely in place. Fig. 17 illustrates the application of a terra-cotta veneer to a brick wall, and shows the anchor *i* that holds one of the blocks in position against the wall. Most of the blocks are fastened to the wall in the same manner. The backs of the blocks are filled in solid with brickwork in cement mortar.

**68. Wall Facings on Concrete Walls.**—Fig. 18 shows the method of securing a terra-cotta facing to a solid concrete wall. In this construction the concrete wall is built first, and the anchor hooks, bolts, etc. are located and placed in the wooden forms in which the concrete is cast. In this system of veneering, the blocks are held in place entirely by the anchoring. It is therefore very necessary that the anchors be installed with great care.

**69.** Three systems of anchoring are shown in Fig. 18. In one system the hooked rod *c* is located so that it will come between the end shells of two adjoining blocks which are formed to fit accurately a horizontal round bar, as shown at *d*. This bar is sufficiently long to extend through the shells of both of the blocks and through the eye of the hooked bar. In this system, the hooked bars must be very carefully located so that they will come at these joints, otherwise they are not serviceable. In the second system of anchorage, the hooked bar *e* is turned around the horizontal bar *f*. This latter bar is located back of the blocks and the blocks are anchored at the top by pieces of iron as shown at *g*. As the bar *f* is continuous, anchors may be placed at any desired location horizontally. The vertical location of this rod must be accurately determined to insure proper connections being formed. The third system is illustrated in the lower part of the figure. At *h* is shown a heavy wire which is left projecting from the wall surface. By means of this wire, the rod *i* is attached to the wall and fits

into the recess that has been formed in the wall for this purpose. The method of anchoring the blocks to the rod *i* is shown at *j*.

**70.** When terra cotta is used as a veneer and cannot be filled with masonry, special precautions must be taken to avoid overloading the blocks and thus causing them to be crushed or the edges to be chipped. Where the space between the wall and the blocks permits of the pouring of concrete, this space and the blocks may be filled with a cement grout, but this work should be done as the work progresses and not after the wall has been completed to a story height.

Terra-cotta facings of the character mentioned are sometimes supported at intervals by means of angles such as shown at *k*, Fig. 18, called *shelf angles*. These are secured to the concrete structure by means of bolts which are placed in the concrete forms at the required locations before the concrete is poured, and after the forms have been removed the angles are attached to the wall by means of these bolts.

These angles must be accurately located and the lower flange should line with the horizontal joint in the terra cotta so that one course of blocks may have a direct bearing on the angle. The blocks resting on the angle should also be anchored to the angle, which is set away from the face of the building by means of washers. This permits of running wire behind the angle and securing the terra-cotta blocks in place, or of the use of bent rods such as shown in Fig. 18.

**71. String-Courses.**—String-courses are usually built into the wall as shown in Fig. 16. This example consists of two courses of terra cotta. The lower member *c* extends into the wall as far as the width of one brick and, since it has to support the weight of the construction above, it is filled in solid with brick and mortar. The upper course, shown at *d*, has a greater projection and also extends into the wall. Both these courses are filled with brickwork as far as the line of the wall face. The projecting part of the upper block is not so filled. Metal anchors of the form shown at *e* are used to tie the pro-

jecting blocks to the wall. The blocks have holes formed in the upper shell, as shown at *f*, to receive the anchors.

**72. Cornices, Medium Size.**—A medium-sized cornice is shown in Fig. 17. The wall supporting this cornice is faced with plain terra-cotta blocks *b*, equal in thickness to one thickness of brick. The cornice consists of two rows of blocks. The lower blocks are richly molded and have a considerable projection in front of the face of the wall. This course must provide a certain amount of support to the upper course and therefore must be filled with masonry and anchored to the backing by anchors such as shown at *h*. The blocks of the upper course *d* extend back into the wall so that they may have good bearings, or supports, and may be covered by the masonry above. This masonry resting upon the backs of the blocks prevents them from tipping outward. These blocks also support a considerable load of masonry, consequently must be filled with brickwork as far as the face of the wall. The projecting portion of this cornice is not filled with masonry, as it is desirable that this part be as light as possible so that it will have no tendency to drop or tip. The blocks in this course should be carefully anchored to the brick wall as shown at *e*. The course *f* projects in front of the face of the wall. Above this course the wall is faced with the blocks *g*.

**73. Large Cornices.**—Large projecting cornices of terra cotta usually require to be supported by the structural-steel frame or by the solid masonry walls of the building. Cornices that are designed for buildings having a steel frame usually have an interior framework of steel shapes, and this frame is connected with the frame of the building in such a manner that the entire cornice is supported by the steel work of the building. This form of construction is very complicated and the structural engineer who designs the frame of the building usually designs it so as to support the cornice properly. The terra-cotta manufacturer will then design the secondary steel members that are required for his work.

**74. Cornices for solid masonry walls,** such as those illustrated in Fig. 21, are usually so designed that the lower

members of the cornice will project somewhat to form a bracket or corbel on which the succeeding members, which have a greater projection, may rest. These lower members are filled with masonry and also anchored to the walls in the usual manner. The upper courses are provided with structural-steel forms *h* which are also anchored and secured to the wall. In this form of construction it is customary to extend the wall of

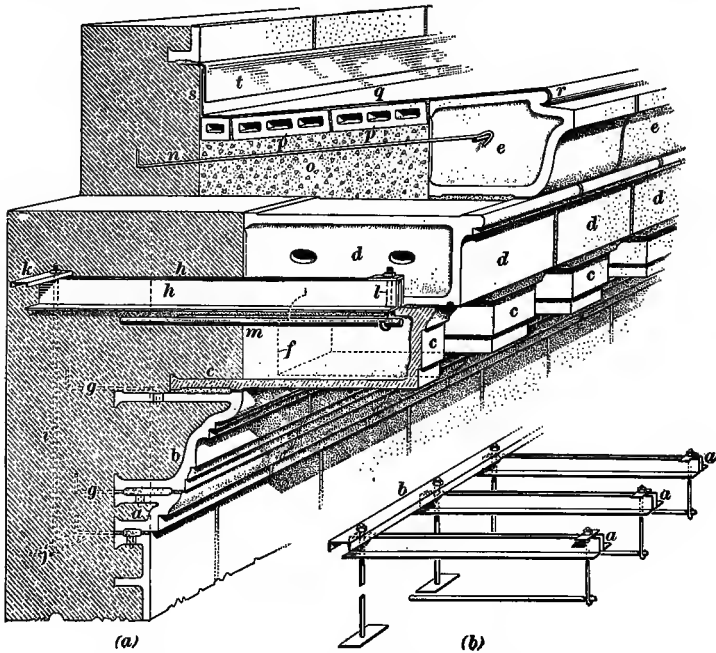

FIG. 21

the building to a sufficient height above the cornice to form a mass of material that will more than balance the weight of the projecting portions of the cornice.

**75.** The blocks that form this cornice are indicated at *a*, *b*, *c*, *d*, and *e* in (a). The outline of an additional block is indicated by the dotted line at *f*. This block cannot be shown in the view given, but occurs above the blocks *b* and fills the space between the brackets *c*.

The blocks *a* and *b* are filled with masonry and are also anchored by means of the tie-rods *g*. These blocks project beyond the wall surface and help to carry the brackets *c* and the wall blocks indicated at *f* between the brackets. The projection of the brackets *c* is so great, however, that the anchors and back filling are not sufficient to hold them in place. Steel angles *h* are therefore installed above each bracket to form a cantilever support. The angles are separated slightly to allow the rods to be placed between them for anchoring into the wall and for the suspension of the blocks. Wall anchors, one of which is shown at *i*, are provided to hold these angles in place and are usually several feet in length. Each anchor has a plate at the lower end, as shown at *j*, to anchor the rod to the wall. The upper ends of the anchors are fastened to the continuous channel *k* which runs parallel with the wall. By means of these anchors and fastenings, the steel angles are prevented from being pulled out of the wall by the weight of the cornice.

The bracket blocks *c* are supported and kept in place by a length of iron pipe *m* which is placed inside the bracket. One end rests on the brick wall and the other end is suspended from the channels by means of a rod *l*. This rod has a thread and nut on the upper portion. By turning the nut the bar *m* is raised until it comes in contact with the upper shell of the bracket and holds the bracket firmly in place. The blocks *d* are formed to fit over the angles *h* and rest on the brackets and the wall blocks between the brackets. The top members of the terra-cotta cornice, shown at *e*, rest on the blocks *d* and are anchored to the wall by rods, one of which is shown at *n*.

In (*b*) is shown a perspective of the steel work used in this system of supports with the various members assembled. The series of cantilever angles are shown at *a*, the continuous channel at *b*, and the anchorage and suspension rods as just described.

**76. Lintels.**—In Fig. 22 is shown an entrance to a building which has walls faced with terra cotta. The jambs and lintel of the opening are also formed of the same material. Since the terra cotta is only a veneer for the brickwork, it is necessary

that steel supports be provided to carry the terra cotta as well as the brickwork over the opening.

Fig. 23 (*a*) represents a section taken through the center of the lintel over the entrance shown in Fig. 22. The steel sup-

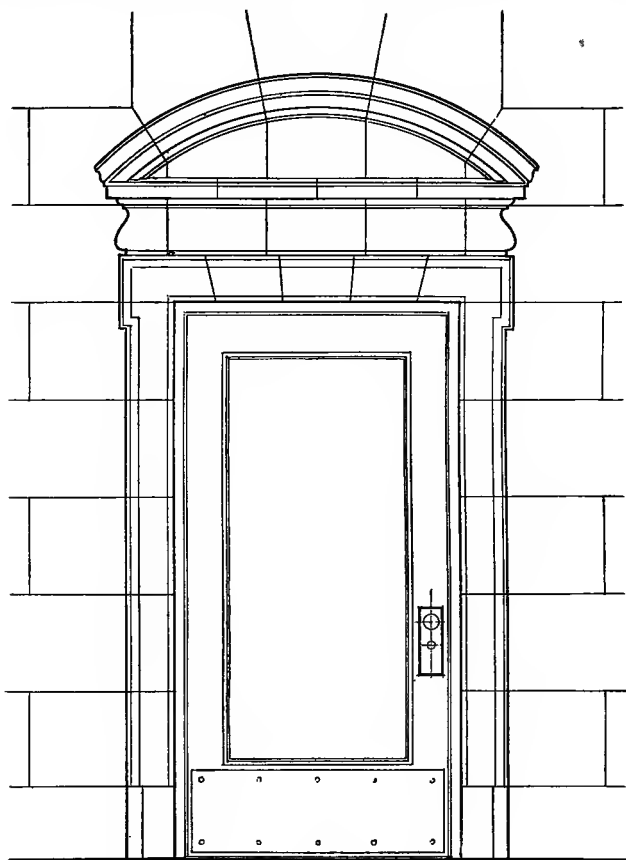

FIG. 22

ports that carry the masonry and terra cotta consist of three angles, as shown at *a*, *b*, and *c*, and one channel *d*. The angles *a* and *b* carry part of the brick wall, and the angle *c* and channel *d* carry the remaining part of the wall and the terra-cotta lintel. The steel member *d* supports the terra-cotta lintel

course *e*, which is suspended from the steel by means of rods *f* and anchored by the anchors *g* so that it is perfectly strong and rigid.

In this figure, sections are shown through the blocks which form the courses *e*, *h*, and *i* to illustrate how the blocks are

formed to fit around the steel work and to show the rods and anchors that secure them in place. In (b) is shown a view of the steel supports *a*, *b*, *c*, and *d* that hold up the lintel. At *e* is shown one of the rods that carry the lower course of terra cotta. These rods are placed between the blocks of the lower course of the lintel, the upper ends of the rods are secured to the steel channel by means of clips *f*, and the lower end is bent around the short bar *g*, which extends through the end shells of two adjoining blocks. At *h* is shown a rod which is formed around the bar *g* and also over the horizontal flange of the angle *a*. This rod prevents the block from tilting when the succeeding course of terra cotta is put in place on top of it. At *i* and *j* are shown the galvanized iron bars that are used to anchor the terra-cotta blocks *h* and *i* in (a) to the steel lintels.

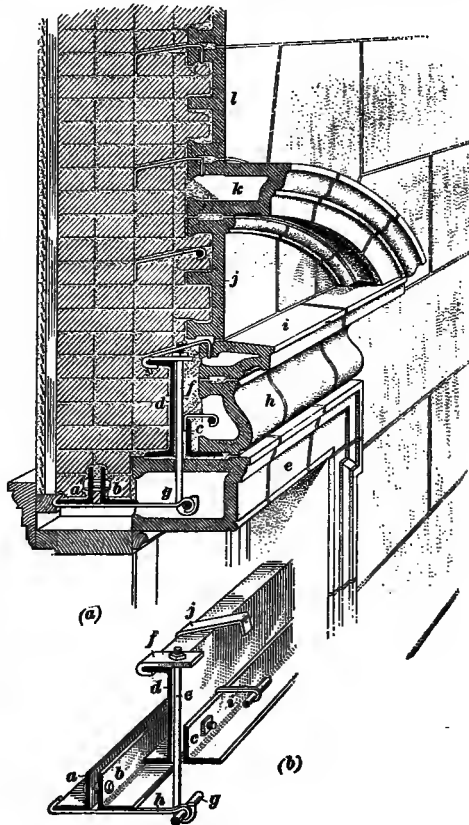

FIG. 23

The terra-cotta blocks *j*, *k*, and *l* in (a) are bonded with the brick wall and also anchored by bars as in the regular form of construction.

The terra-cotta lintels of the entrances shown in Figs. 2, 3, and 5 are all formed of courses of blocks and carried by steel members that are concealed in the masonry, thus permitting the exposed under side of the lintel, called the *soffit*, to be finished to correspond with the jambs, as is shown in Fig. 5. The principle involved in the construction of these lintels is the same as that shown in Fig. 23, the form of the

blocks and the steel work being adapted to meet the requirements of the different designs.

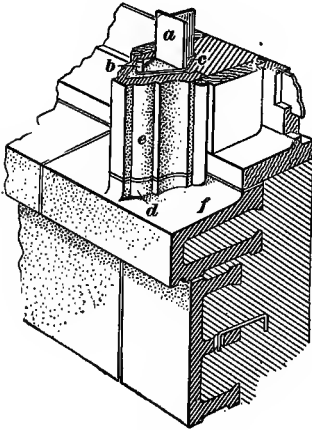

FIG. 24

### 77. Window Mullions.

Window mullions or slender piers that are formed of terra cotta or have a facing of that material, should be provided with steel posts formed of T's, angles, or gas pipe, to which the terra cotta may be anchored, and which will give stiffness to the piers.

In Fig. 24 is shown a mullion that has a terra-cotta facing. A steel T bar *a* is used to reinforce the mullion. A short iron bar *b* is placed in an opening in the top of the terra-cotta block and this is anchored to the T bar by means of a heavy wire. The bar *b* extends into the bottom shell of the succeeding block. Round or square bars of iron are sometimes used as anchors, one end being formed to turn down into the opening in the top of the block and the other end being formed to fit around the T. This method, however, does not anchor the bottom end of the succeeding block.

In this illustration it will be noted that the lower part *d* of the mullion is formed on the terra-cotta sill-course. This is done to secure a level bearing for the block *e*, as the sill is formed with a slope, as shown at *f*.



Examples of mullions which have steel reinforcement are

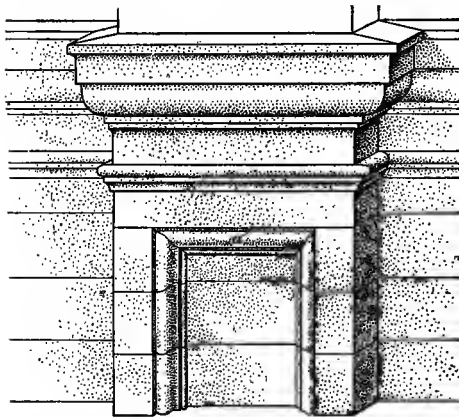

shown between the windows over the front entrance of the bank building illustrated in Fig. 3, between all windows of the residence shown in Fig. 7, and between the windows of the apartment building shown in Fig. 8. This reinforcement is absolutely necessary for the mullions shown in Fig. 7, as the mullion is too small to permit of sufficient masonry backing to give any strength to the terra cotta or to permit of anchoring the various mullions. The transom blocks which form the bars shown in this illustration are also reinforced with steel.

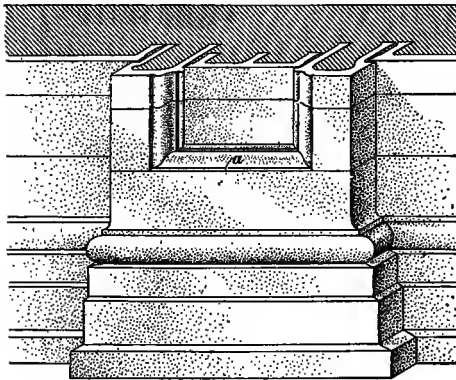

(a)

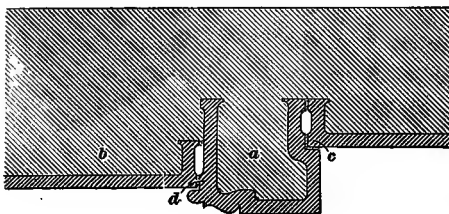

(b)

FIG. 25

### 78. Pilasters.

In designing pilasters, the forms of the blocks and manner of jointing them where they intersect with wall blocks require particular consideration in order that the

vertical joints may be concealed or, at least, not easily seen.

The pilaster shown in Fig. 25 has a paneled face and each course in the width of the pilaster is formed of three pieces. The panel is formed of one piece and the side members of the other pieces. At *a* in (*b*) is shown a plan of one side piece, and at *b* a portion of the panel. At *c* and *d* the manner in which the block is formed to conceal the vertical joints is shown. The moldings at the top and bottom of the panel, as

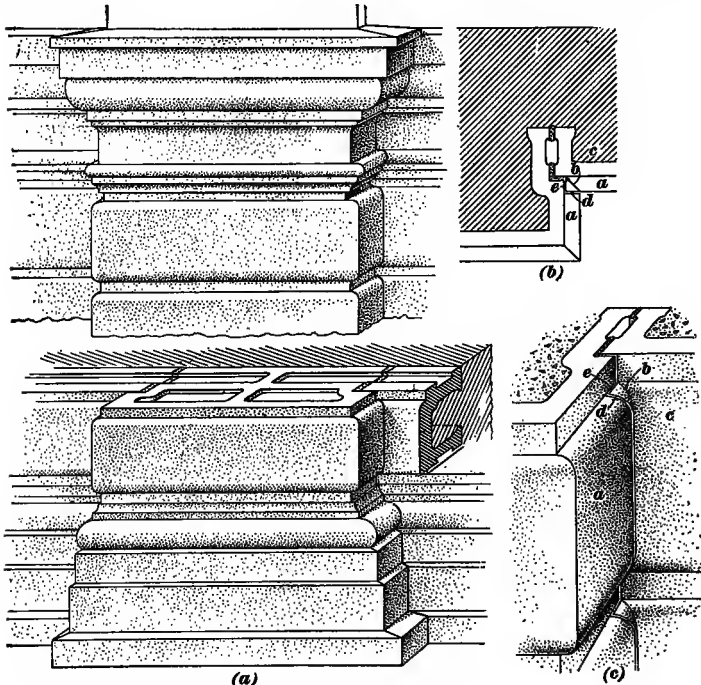

FIG. 26

shown at *a, a* in (*a*), are formed on the same blocks as the top and bottom sections of the panel.

The pilaster shown in Fig. 26 has horizontal joints known as *rusticated joints*. This is a very practical design for large blocks, as a slight warping of the blocks in the burning is less apparent than in the plain smooth-faced pilasters. In the rusticated design, the horizontal joints between the blocks are not conspicuous; as they are located at the tops of the recessed

surfaces between the projecting parts of the blocks. This design requires a somewhat different form of joint, however, at the intersection of the pilaster with the wall, as one part of the block projects beyond the other portions. In (*b*), at *a*, are shown these projecting parts, and at *b* is shown the return which is formed on the wall block *c*. In (*c*) is a view of this joint, showing the projecting part of the wall block *c* extending behind the similar portion of the pilaster block. The portions *d* and *e* of the joint will appear as shown. These joints should be made as thin as possible so that they will not be easily seen. This form of block allows of a square joint between the two intersecting blocks instead of a miter joint, and any cutting of the blocks that is necessary to make them fit properly may be easily done without disfiguring the joint.

**79. Columns.**—Columns of terra cotta are built up in sections from 10 to 16 inches in height, called *drums*, from their cylindrical drum-like shape. For columns not exceeding 14 inches in diameter these drums can be made in single pieces.

In the case of columns of large diameter, it is not practical to make the drums in one piece, as slight inequalities of shrinkage are likely to occur. The best practice is to use a sufficient number of vertical joints to make the drum of four or more pieces, depending upon the diameter of the column. The vertical joints should be continuous for the whole length of the shaft wherever practicable. The heights of the courses should not exceed 16 inches.

If the terra-cotta column is to enclose a structural-steel column, the drums must be made in pieces so that they can be placed around the steel column.

**80.** In Fig. 27 (*a*) is shown a terra-cotta column of small size, in which the drums can be made in one piece if desired. The drums are shown at *a*, *b*, *c*, etc. The drum *b* is in one piece, and *a* and *c* are each in five sections. A plan of the drum *b* is shown in (*c*) and a plan of the drums *a* and *c* in (*b*). The plan (*b*) shows the outer shell upon which the flutes are cast, also the radiating webs and the vertical joints between the sections. The right-hand side of the plan shows

the top of the block with anchors *d* holding the blocks together, also the raised parts of the bed joints *e*, which are ground

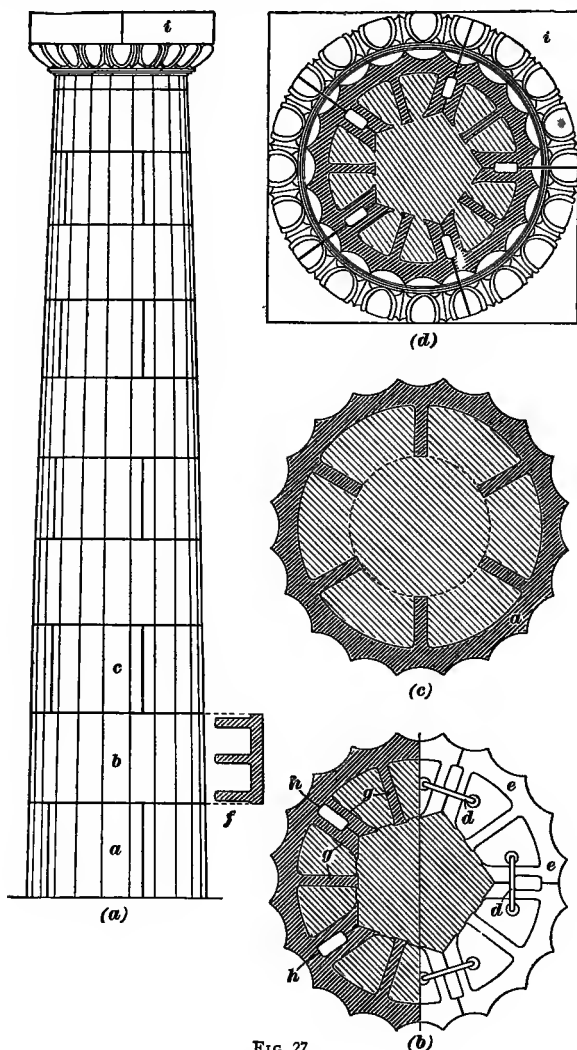

FIG. 27

when necessary to make the blocks fit together.' At *f* in (a) is a vertical section through a block, showing the horizontal ribs

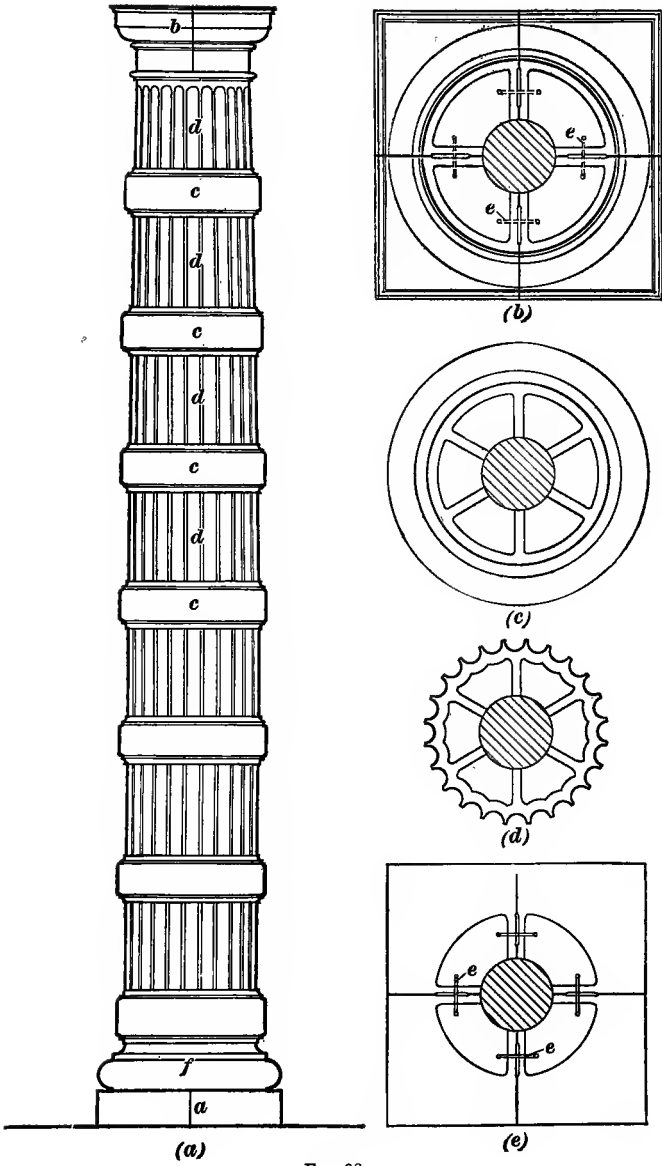

FIG. 28

and the raised joints that are shown in plan at *e* in (*b*). The left-hand side of the plan (*b*) shows the radiating webs *g* and the joints *h*. The capital is generally made in sections. A plan of the capital of the column, in which the observer is looking upwards, is shown in (*d*). The ornamental portion of the capital is divided into five parts and the square abacus *i* into four parts.

**81.** When the column is built, the center of the column as well as the hollow spaces in the block are filled with masonry. Concrete is the cheapest and best material to use for this purpose. A column such as the one just described is not strong and should not be expected to support a great load. When there is a considerable load to be supported a steel column should be placed inside the terra cotta one in the manner that will be described later in connection with Fig. 29.

**82.** A design of column known as a *banded column* is shown in Fig. 28 (*a*). With the exception of the base *a f* and the capital *b*, the sections that form this column are all of the drum shape, made without vertical joints. The advantage of this design, for terra-cotta construction, is that the plain sections *c*, being located between the fluted sections *d*, conceal irregularities in the flutes that may be caused by the burning and which would be apparent were these fluted sections placed together. The forms of the shell and the interior webs of this column are similar to those of the column shown in Fig. 27.

A plan of the base block *a* in (*a*) is shown in (*e*). A plan of the cap viewed from the under side is shown in (*b*). Both base and cap are formed of four pieces which are clamped together as shown at *e* in both these figures. The clamps are shown in dotted lines, as they occur on the upper side of the capital and could not be seen in the view given. A plan of the circular portion *f* of the base is shown in (*c*), and the plan (*d*) represents the fluted drums *d* in (*a*).

**83.** Columns that are required to support a weight in excess of the load the terra cotta will safely carry should be provided with a structural-steel column in the center. If the terra-cotta column is small and the sections are in single drums,

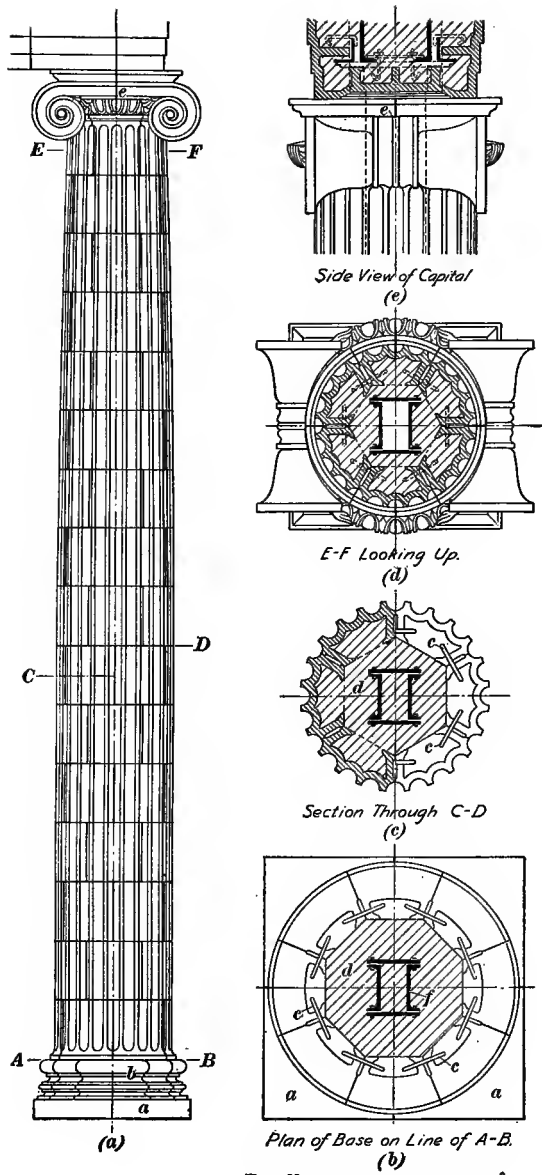

FIG. 29

it will be necessary to erect the steel column first and lower the terra-cotta drums down from the top over the steel column.

Columns of large dimension cannot be economically or successfully formed in single drums, but must be built up of segments. Columns of this character usually contain structural-steel supports, and the terra-cotta segments must be designed to fit around the steel work which has been previously erected.

To conceal the vertical joints as much as possible in the completed column, frequently flutes and beads are employed in the design and the vertical joints are located in these members. Segments that form the columns should be anchored together by means of iron clamps hooked down into holes cast in the shell or webs of the units and the hollow spaces in the blocks should be filled with brickwork or concrete.

**84.** In Fig. 29 (*a*) is shown a fluted column having a molded base and an ornamental capital. This terra-cotta column encloses a steel structural column and is of a large diameter. The base, shaft, and cap are formed of several units and the joints between them are indicated in the illustration by heavy lines.

In (*a*) is shown the complete column. The base block *a* is formed of four parts, as in the square part of the base shown in Fig. 28. The molded base *b*, Fig. 29 (*a*), is shown in plan in (*b*) and is formed of eight segments which are bonded together by means of iron clamps *c*. A section through the fluted shaft of the column, taken on the line *CD* in (*a*), is shown in (*c*), six segments being used to form the drum. These are also anchored together by means of clamps *c*.

The right-hand part of this section is taken through the joint and therefore the clamps *c* can be seen. The left-hand side of the section is taken through the middle of the block and shows the concrete or cement filling at *d*. A plan of the under side of the cap, taken at *EF*, the observer looking up, is shown in (*d*); the heavy lines indicate the jointing of the four parts that form the cap. Joints on one side of the cap are shown at *e* in (*a*) and those of the other side of the cap are shown at *e* in (*e*).



The steel column around which the terra-cotta column is formed is shown at *f* in (*b*), and the space that is filled with concrete or brickwork is shown at *d*.

An example of cylindrical columns formed of plain blocks of terra cotta is shown in Fig. 3. In Fig. 2 are shown columns that have structural-steel members in the cores. These columns are designed so that the vertical joints between the blocks occur

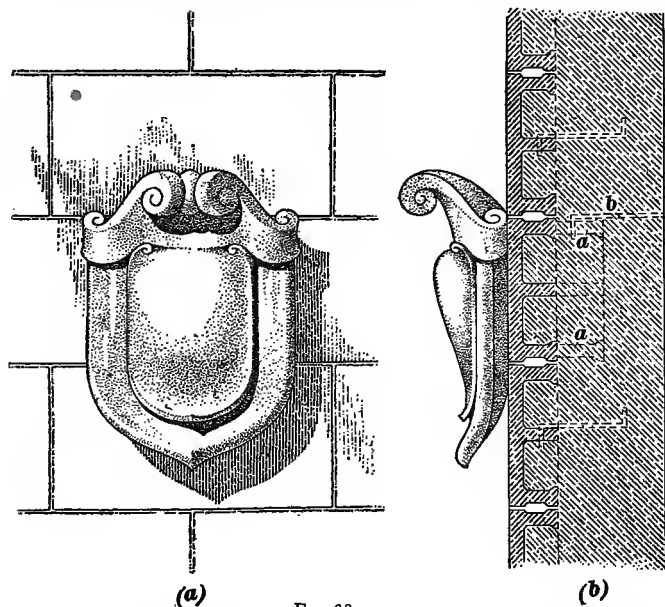

FIG. 30

at the angles of the columns and are thus partly concealed by an ornamental beaded treatment.

**85. Cartouches.**—A cartouche is a form of ornament consisting generally of a panel in the shape of a shield, oval, or rectangle, which is surrounded by ornaments consisting of ribbons, scrolls, foliage, etc. The central panel may be decorated with a coat of arms, a motto or some similar motif, or left plain. Cartouches are used frequently as a means of decoration and their ornamental character makes them expensive to execute in stone. They are, however, comparatively inexpen-

sive when made of terra cotta. A small cartouche is shown in Fig. 30. An elevation is shown in (*a*) and a side view in (*b*). The method of securing the cartouche to the wall is shown in (*b*), in which the block, of which the cartouche is a part, extends back into the wall as shown at *a*, and an anchor *b* firmly secures the cartouche to the wall.

**86.** Cartouches are often quite large and made up of several blocks. The joints in such cases are carefully designed so



FIG. 31

as not to cross the principal parts of the cartouche. An example of a large cartouche is shown in Fig. 31. Joints are shown on each side of the helmet and in corresponding positions in the lower part of the cartouche. The shield containing the eagle is in one piece, as a joint through this part of the cartouche would be unsightly.

**87.** A very conspicuous example of the use of terra-cotta cartouches in the design of the building is shown in Fig. 8. In this design cartouches form the central parts of ornamented panels, as in the panel immediately over the entrance to the building; in other places they are used as inserts in the wall.

**88. Balustrades.**—Vertical members of terra cotta, such as balusters, urns, finials, etc., are usually formed of small pieces and held together by round iron rods extending up

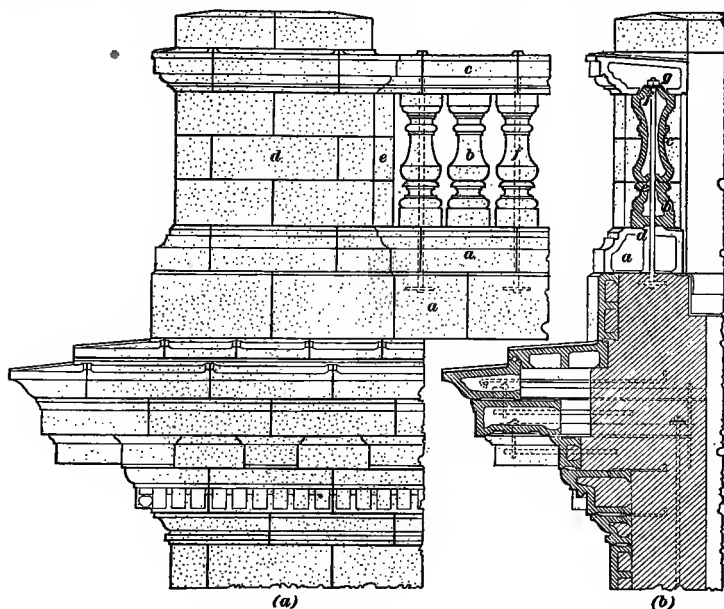

FIG. 32

through hollow cores in the centers. On each end of these rods is a nut and washer, and when the top nuts are tightened the different pieces of terra cotta that compose the baluster or finial are drawn closely together.

When balusters are short, each can be cast in a single piece having a hollow core to receive the rod and to permit of proper shrinkage in the burning. Long balusters can be molded in halves, which, after drying, are placed together and the joints smoothed off and finished so they will not show. The com-

pleted baluster is then placed in the kiln and burned. When a long baluster consists of a base, shaft, and cap, however, joints are formed in the baluster so that it may be cast in three pieces, each of which is small. The twisting and warping due to burning is thus reduced to a minimum.

Balustrades are formed of a series of balusters which rest on a terra-cotta base and are covered at the top by a terra-cotta cap, or railing, and the balusters are anchored to this base and cap to make a strong and rigid construction.

**89.** A portion of a balustrade of this description is shown in Fig. 32 (*a*) and a section through the balustrade and one of the balusters is shown in (*b*). In (*a*) an elevation of the base on which the baluster rests is shown at *a*, the baluster at *b*, and the cap, or railing, at *c*. The balustrade terminates at the end of the building in a pier as shown at *d*. This pier is faced with regular-shaped terra-cotta blocks and is constructed in the same manner as terra-cotta faced walls. At *e* is a plain pilaster adjoining the pier.

The dotted lines at *f* indicate a rod that extends from the base, through the baluster, and into the cap. In this illustration the rods are inserted in every other baluster instead of in each one. In (*b*) is shown a section through the balustrade in which the baluster is shown to be formed of two parts, *b* and *c*. Dowels are formed on the base *a* and also on the members of the baluster which fit into corresponding recessed parts as are shown at *d*, *e*, and *f*. At *g* is shown a flat bar that extends the entire length of the balustrade and through which the rods pass and are secured. This portion of the balustrade requires to be completed before the cap members are set in place.

**90. Domes.**—Architectural terra cotta has come into wide use as a facing material for the interior and exterior surfaces of domes. It is particularly adapted to this use because the material is light in weight and permits of extensive color effects, and is impervious to the weather.

The terra-cotta facing is supported on a frame made of rolled-steel sections of light weight, or, more generally, on a light concrete dome which may or may not be supported on

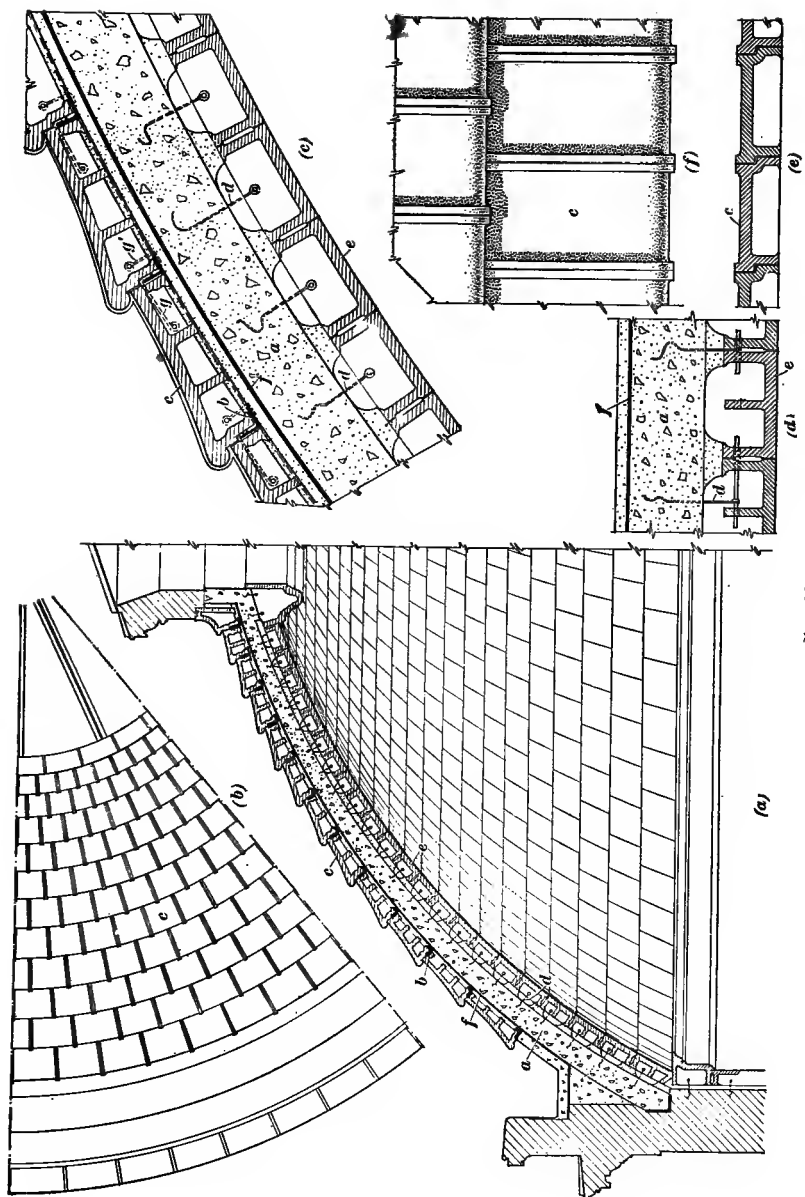

FIG. 33

steel shapes. Fig. 33 shows the construction of a dome made of concrete which is faced both on the outside and on the inside with terra-cotta blocks. In (*a*) is a cross-section through one half of the dome and in (*b*) is a plan of part of the outside terra cotta. The reinforced concrete which forms the structural base on which the terra cotta rests is shown at *a* in (*a*). The steel angles to which the outside terra-cotta work is attached are shown at *b*; the exterior terra-cotta blocks *c* rest on the angles as well as on the concrete and are also wired to the angles.

The blocks used on the outside of the dome have lips that project over the next row of blocks below. The vertical joints between these blocks are rectangular raised joints, as shown in (*e*) and (*f*). A dome constructed in this manner should have a waterproof coating of felt and tar above the concrete and under the terra cotta to prevent water from working its way through the dome from any leaks that may occur in the raised joints of the outside terra-cotta covering. This waterproofing is indicated at *f* in views (*a*), (*c*), and (*d*). All the outside joints should be filled with roofer's elastic cement to insure their permanence and waterproofing value.

A section through the individual blocks is shown at *c* in (*c*). The steel angles *b* support the blocks which rest against them, and, in addition, the blocks are wired to the angles as shown at *g, g'*. These wires extend between the joints of the blocks and are secured to pins that pass into holes in the adjacent blocks. A section through the raised joints is shown in (*e*). The wire just referred to is placed in the joints between the blocks. The joint is rabbetted, which tends to make it waterproof, but should nevertheless be filled with good elastic cement. The tiles themselves are also set in elastic cement.

The inside lining of the dome, as shown in Fig. 33 (*a*), is formed of blocks *e* secured to the concrete dome by means of stout wires *d* that are set in the concrete when it is cast. These wires, shown more clearly in (*c*) and (*d*), extend below the lower surface of the concrete and their lower ends are fastened to short rods that extend through holes that occur in all the blocks and thus the blocks are held securely in place.

### SHIPPING AND HANDLING TERRA COTTA

**91. Packing.**—Terra cotta is usually shipped from the factory in box cars, as they afford better protection for the blocks than open cars do.

The blocks should be carefully packed with plenty of hay or straw surrounding them. They should be laid in courses in the car and be so placed that no finished edges or faces come in contact with the car or adjoining pieces. All blocks should be so braced or wedged with the straw or hay that they cannot move about in the car.

The courses, or layers, in the car should consist of blocks having consecutive numbers, so that when the blocks are removed from the car upon its arrival at its destination they may be stacked in corresponding layers, or courses. This method will facilitate finding the blocks in their proper order when they are to be placed in the wall.

**92. Receiving and Checking.**—When shipping the terra cotta, the manufacturer always sends to the contractor who is to erect the material a list of the pieces included in the shipment.

When the blocks are received at the building they should be checked with the list, and if any listed pieces are missing, the factory should be notified immediately so that the pieces needed may be shipped without delay.

**93. Assorting and Stacking the Blocks.**—As there is danger of the terra cotta being chipped by frequent and careless handling, it should be assorted as it is received at the building and stacked in such a manner that it will not need further handling until it is required to be placed in the walls of the building. For this reason it is customary to form separate stacks of the blocks that form each part of the design, and to place the blocks that are required first at the top of the stack.

In stacking the blocks, care should be taken to prevent all edges and finished faces from coming in contact with hard substances or with one another. The best method is to pile the pieces in layers with strips of boards between the layers.

If blocks are not to be used immediately, they should be stored in a shed or be covered with boards and waterproof paper to prevent their being injured. If a block is broken it will take from six to eight weeks to send to the factory and duplicate it.

**94. Handling the Blocks.**—In conveying the blocks from the stacks to the scaffold, the pieces should be carried singly, if possible, one block of ordinary size being a good load for one man. If it is necessary to use a wheelbarrow, the block should be placed on straw with the face up and only one block should be carried at a time, unless the blocks are very small. In that case several small blocks may be placed in the wheelbarrow, provided that straw is carefully packed around them.

---

#### SETTING THE TERRA COTTA

**95. Backing-Up the Blocks.**—Terra cotta is backed up with masonry in much the same manner as cut stone or face-brick work. When terra cotta is used as a veneer for a masonry wall, the hollow spaces in the blocks are generally filled with masonry. When the terra cotta projects beyond the face of the wall, the masonry filling of the blocks usually does not extend very much beyond the face of the wall, consequently steel anchors, such as have already been described, are used to tie the terra cotta to the masonry. These anchors if not embedded in masonry should in all cases be covered with cement grout as a protection against rust. It is dangerous to omit this protection.

Terra-cotta facings for concrete walls frequently do not permit of filling the back of the blocks with masonry, but grout may be poured back of the blocks to fill the voids, if the circumstances require it.

**96. Fitting.**—While terra-cotta blocks are usually fitted together and the edges jointed at the factory, occasions arise when it is necessary to cut the blocks at the building before they can be set in place. This may be due to errors in measurements or to irregularities in the structural parts of the building.



The shells and webs of the blocks sometimes require to be cut to fit structural-steel members or to provide additional openings into which anchors may be placed. This cutting should be done only by skilled workmen and every precaution should be taken not to injure the block either on the exposed face or in the parts that are essential to its strength and anchorage. It is, however, not often necessary to fit the terra cotta at the building.

**97. Anchoring.**—The method of anchoring terra-cotta blocks will depend upon the form of the blocks and the structure to which they are to be attached and must be adapted to meet the peculiar requirements of each case.

The most essential feature of the anchor, next to its strength, is that it shall form a rigid connection between the block and the backing to which it is fastened. The manner in which it is made rigid will depend upon whether the anchor is of a form that can be adjusted or one that is of a fixed form.

Horizontal anchors that connect with the blocks and extend back into the masonry do not require to be adjustable. They are set into the holes of the blocks and masonry is built around the opposite ends so that when the mortar becomes hard the anchors cannot be moved.

Anchors that fit over a structural-steel member back of the block are sometimes formed by bending one end to fit into the block. The anchor is then placed in position and by means of a hammer, the opposite end is bent so that it will accurately fit over the steel. This method is possible only where the anchors are formed of small bars or straps that can be bent without endangering the terra-cotta blocks.

When heavy anchors are used to fit over structural-steel members, they may be formed with turned-down ends and of such lengths that they can be easily driven into position. They may be made slightly longer than required, and when set in place may be wedged at either end by means of small pieces of broken terra-cotta blocks until they are rigid, after which mortar should be slushed around the anchor connection at the block to make sure that the anchor will remain in place.

For overhanging blocks that are carried by suspension rods, an adjustable form of hanger is used. The lower end of the rod is formed with a hook through which a bar extends horizontally into adjacent blocks. The upper end of the suspension rod is provided with a screw thread and nut. The horizontal bars afford a bearing for the terra cotta and the suspension rods are brought to a rigid condition by screwing down the nuts on the upper ends. In this manner the entire weight of the block is carried by the rod.

**98. Bedding in Mortar.**—All terra-cotta blocks should be well bedded in mortar and pressed down so that each piece will have a uniform bearing throughout the length of the block. Mortar joints for the top surfaces of all sills, projecting courses, cornices, and copings should be carefully formed so that no openings will be left through which water may enter the joints.

In setting heavy pieces of terra cotta, wooden wedges of uniform thickness are sometimes placed in the mortar bed to secure joints of uniform sizes, as the weight of the block would otherwise cause the mortar to be pushed out of the joint before the mortar becomes hard.

The mortar joints at the face of the wall frequently are finished as the blocks are laid, instead of being pointed later. When this is to be done, a rough mortar joint is formed with the trowel when the block is put in place and in the course of several hours, when the mortar has become sufficiently hard, it is smoothed with a tool to secure the form of joint desired.

**99. Filling.**—For large projecting cornices, such as shown in Fig. 21, concrete is sometimes used as a filler, as shown at *o*, instead of terra cotta.

On this filler is placed a row of regular building tiles *p* to form a surface on which the sheet-metal covering *q* may be laid. This covering extends over the front member of the cornice and returns into a groove, or reglet, that has been formed in the face of the blocks, as shown at *r*. It is secured in place by means of wedges of lead and the intermediate spaces are filled with roofer's elastic cement. At the wall, the

sheet metal turns up as shown at *s*, and is cap-flashed in the usual manner, as shown at *t*.

**100. Mortar.**—Mortar for setting of terra cotta is usually formed of cement and sand, with a small amount of thoroughly slaked lime added to make the mortar more plastic and thus facilitate its spreading. Mortar for this purpose should be composed of one part Portland cement and two parts of clean sand and  $\frac{1}{10}$  part of hydrated lime.

Lime mortar is not suitable for this form of construction, as it sets slowly and therefore prevents rapid progress with the work, for the weight of the terra cotta would squeeze the mortar out of the joints before it had time to become hard. Lime mortar will, moreover, disintegrate in time and leave open joints.

When the joints in the terra cotta are to be pointed after the work has been completed, the mortar in the joints should be raked out to a depth of from  $\frac{1}{2}$  inch to 1 inch as soon as the blocks have been set. Also, loose particles of mortar on the face of the blocks should be removed to facilitate cleaning the blocks later on.

**101. Protecting the Terra Cotta.**—All projecting members of terra-cotta courses should be temporarily protected after the blocks are laid, so that they will not be broken by falling bricks or other building material. Planks or boards are used for this purpose and it is usually specified in the carpenter's, mason's, or the terra-cotta contract, that the contractor shall protect all terra-cotta work until completion of the building. A board slightly wider than the projection should be laid along all projecting members and fastened securely in place by crosspieces tacked to window frames, floor joists, or wherever it is possible to make a fastening. Ornamental panels or other ornamental terra-cotta work should be entirely covered to make sure that they will not be injured during the process of building.

**102. Terra-Cotta Foreman.**—For a large or complicated job of terra cotta, a terra-cotta foreman, who is an expert



FIG. 35



FIG. 36

in this work, is sometimes employed, at the owner's expense, to supervise the terra-cotta work.

It is the duty of this foreman to see that the material arrives on the building site at the proper time and in sufficient quantities so that there will be no delay in erecting the building. He also checks off the blocks to see that they are all at hand and causes them to be piled in such order that they can be taken as wanted without unnecessary delay or lost labor.

He is responsible for the proper stacking of the blocks to keep them from injury and for seeing that they are covered up and protected with planks or boards. The supervision of the actual setting of the blocks is also part of the duties of the terra-cotta foreman.

**103. Washing and Pointing the Terra Cotta.**—As a general rule, terra-cotta blocks are laid up without the joints being pointed, the rough mortar of the joint being raked out slightly before it becomes hard. Just before the completion of the building, the face of the terra-cotta work is washed and the joints pointed. This work can be done by the masons who set the terra cotta or by another contractor who is a specialist in this line of work. The latter is the usual practice for cleaning buildings composed of brick or stone walls and terra-cotta trimmings, and one contractor is then responsible for the cleaning and pointing of the face of the entire building.

Unglazed terra cotta should be washed with a weak solution of muriatic acid such as is used in cleaning brickwork, a 3-per-cent. solution being sufficiently strong for this work. This may be applied with a coarse brush and the surface of the terra cotta scrubbed until all cement stains and lumps have been removed. Steel brushes, such as are used in cleaning stone and brickwork are not suited for cleaning terra cotta, however, as the steel bristles may injure the glaze of the material. Steel or iron tools, pails, etc., should never be used in connection with acid in cleaning the fronts of buildings. Glazed terra cotta never requires acid. The best cleaning material to use is an abrasive soap or washing powder. Lumps of mortar should be soaked with water and removed with a wooden stick.



*Courtesy of the Atlantic Terra Cotta Company*

FIG. 34



FIG. 35





FIG. 36



FIG. 37

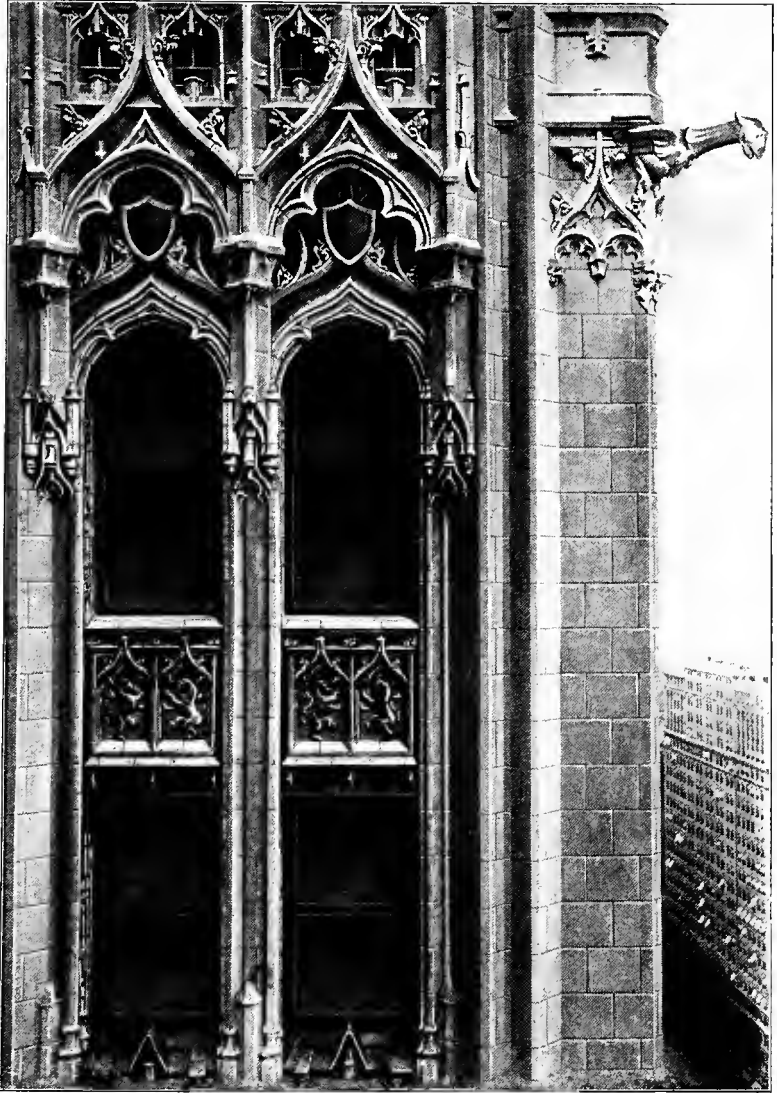

FIG. 38

The pointing materials may be ordinary cement-and-sand mortar, white-cement mortar, or colored cement mortar, as may be desired. For white enameled terra cotta, white mortar is generally used to make the joints as near the color of the terra cotta as possible. Pointing mortar may be colored any desired shade to match any color of terra cotta, but mineral colors only should be used, as coloring matter composed of vegetable colors will fade.

Joints in terra cotta are usually close, and the pointing is done with a tool about an eighth of an inch in thickness. This tool makes a joint that is slightly depressed at the center and the mortar is pushed firmly against the edges of the blocks.

---

#### EXAMPLES OF TERRA-COTTA WORK

**104.** One of the most noteworthy examples of terra cotta applied to the exterior of a building is shown in Fig. 34, which is a view of the Woolworth building in New York City. The general color of this building is a light cream, while the panels between the windows are finished in various colors such as golden yellow, green, sienna, and blue. The style of architecture employed is Gothic. The terra cotta, which is mat-glaze finish, was set in mortar composed of cement, white sand, and a waterproofing compound. The building was washed down with Gold Dust washing powder and sand grit, no acid being used in cleaning.

**105.** Notwithstanding the lightness and delicacy that characterize the appearance of this building, the details when seen at close range are very large in actual size, as shown in Fig. 35. In this illustration is shown the figure of a man which gives an idea of the relative size of the ornament. Other examples of the details used in this building are shown in Figs. 36 and 37. In Fig. 38 is shown a detail of two windows in one of the upper stories of the building. At the sills of the lower windows is shown the method of protecting portions of the ornamental work by means of boarding.

# HOLLOW TILE

---

## ADVANTAGES AND NATURE OF HOLLOW TILE

**1. Introduction.**—Hollow terra-cotta blocks have been used for many years as a means of protecting the steel constructional parts of tall buildings from fire, as well as for constructing fireproof partitions, furring, etc. The employment of hollow terra-cotta blocks for the outside walls of buildings, particularly of residences, is more recent. Their use for this purpose is, however, quite extensive, and hollow-tile construction for walls of buildings has become thoroughly standardized. This style of construction is being used with increasing frequency where low-priced fireproof buildings are in demand.

**2. Advantages of Hollow-Tile Construction.** There are several advantages claimed for hollow-tile construction. Compared with wooden construction, it has the advantages that any masonry construction has over wooden construction; namely, greater stability, durability, and fire-resisting qualities, as well as a lower cost of maintenance. No matter how carefully a frame building is built and regardless of the excellence of the materials used and the high quality of the labor employed, its life is comparatively short. It must be kept in repair, and there is an increasing necessity for repairing as time goes on. Hollow-tile buildings, of course, also will need repairs, but the repairs necessary to keep a tile building in good condition are very much less than for a frame building. Hence, although the first cost of a building of hollow-tile con-

struction is greater than one of wooden construction, the ultimate cost, including cost of maintenance, when extended over a period of years, is less for the tile construction.

**3.** In the United States, where wood has been very plentiful and comparatively cheap, frame construction has flourished, but the enormous loss by fire in frame buildings is gradually leading to the erection of fireproof buildings of masonry.

Since tile is made of clay and has been thoroughly burned, it has fire-resisting qualities similar to those of brick, and buildings made of it can obtain low insurance rates.

For garages, hollow tile is one of the best materials that can be used, since it is not only economical and durable but possesses the most important requisite of any well-designed garage, that it shall be fireproof. It is not necessary to plaster the tile on the inside of a garage, as the wall can be made attractive by selecting tile with one face smooth or glazed and carefully pointing up the joints.

**4.** Another claim that is made for hollow tile is that it is sanitary and vermin proof, which makes it particularly adaptable for use in residences.

**5.** A further advantage of hollow-tile construction is that it is generally less expensive than any other form of masonry construction. This is an important consideration in the minds of architects and their clients. This economy in first cost is brought about partly by the nature of the hollow tile. Each tile is much larger than a brick and can be laid much more quickly than an equal volume of brickwork. A workman can, consequently, lay more cubic feet of wall with tile than he can with brick in a working day. The tiles are easily manipulated and can be broken and trimmed to fit peculiar conditions that are found when building walls.

Hollow-tile walls are strong and light in weight, which makes the load on the footings less than that of a solid brick wall. This saving in weight means an economy in the size and cost of the footings.

**6.** Another advantage claimed for hollow-tile construction is that the walls and floors are hollow. Each block of hollow tile consists of a sort of clay box divided by interior webs or partitions so that a wall built of hollow tile is honeycombed with holes. These holes, or cells, are excellent in many ways. For instance, the dead air contained within these cells provides excellent insulation against temperature changes, so that a hollow-tile wall is usually warmer in winter and cooler in summer than a wall of solid masonry. These cells also prevent the penetration of water through the walls.

**7.** "It is claimed that interior plastering can be safely applied directly to the hollow-tile blocks, thus saving the cost of furring and lathing. It is not considered good practice to plaster directly upon the inner surface of a solid brick or stone wall, as dampness often works its way through and is apt to stain the surface of the plaster and to destroy decorations or papers that may be applied to the plaster.

**8.** Walls of hollow tile are easily arranged to contain heating and plumbing pipes as well as electric wires and conduits, either by building chases in the wall in advance of the installation of the pipes or by placing the pipes first and building the blocks around them. A common method, when the cells are set vertically, is to break slots or chases in the completed wall when it is time to run the pipes. This is easily accomplished, as the webs are quite thin and can be broken by sharp blows of a hammer and chisel. Care must be exercised, of course, in breaking into the finished wall to avoid damaging it too much.

**9. Manufacture of Terra-Cotta Tile.**—The manufacture of terra-cotta hollow tile is a comparatively simple process and consists, briefly, of kneading clay until it is of the proper consistency for molding, after which it is shaped into blocks and then baked in kilns.

**10. Density of Terra-Cotta Tile.**—Hollow terra-cotta tile is made in various densities, and three classes of the material are commonly recognized; namely, *dense*, *semiporous*,

and *porous*. These terms, however, are somewhat indefinite. For instance, when a kiln of tile is burned, the material closest to the fire is burned the hardest and consequently is dense, while the remainder of the tile in the same kiln might be classified as semiporous. Porous tile is of a different composition, and when burned is filled with numerous air spaces which make this material light and porous.

Most of the tile now manufactured is of the semiporous class because semiporous tile has been found by experience to be the most satisfactory ware.

A frequent requirement of building codes regarding the density of tile is as follows: "Tile used for bearing walls shall not have more than 12 per cent. absorption." That is, the tile when immersed in water shall not absorb more than 12 per cent. of its weight of water.

**11. Dense Tile.**—Dense tile, being burned the most, is therefore hardest and strongest, and is used where heavy loads are to be supported. It is used where walls are to be veneered with brick or where the tile is exposed to the weather. Unless the surface is scored, or grooved, plastering will not adhere to the surface of dense tile.

**12. Semiporous Tile.**—Semiporous tile is the kind most used in houses and small buildings. Tile of this class is sufficiently hard burned to be fairly impervious to moisture and to make good substantial walls, but not too dense to prevent plaster adhering to it strongly. The tiles are, nevertheless, generally scored or grooved so as to afford a good bond for plaster or mortar.

**13. Porous Tile.**—Porous tile is rarely used and should never be employed for any purpose except for building inside walls, or partitions.

**14. Glazed Tile.**—Tile for certain purposes is sometimes glazed. Glazing is done by introducing a quantity of common salt into the kiln when the material is nearly burned and this produces a glass-like film over the entire exposed surface of



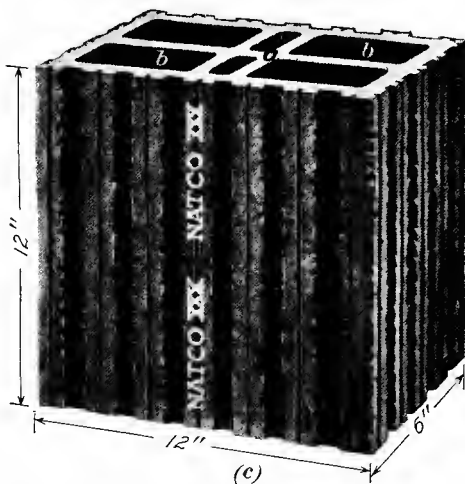
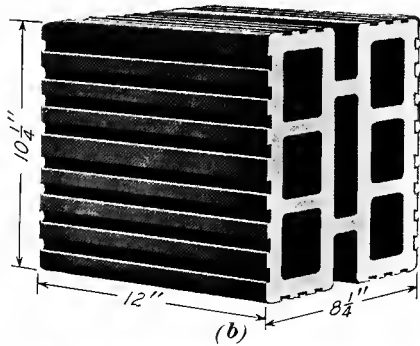
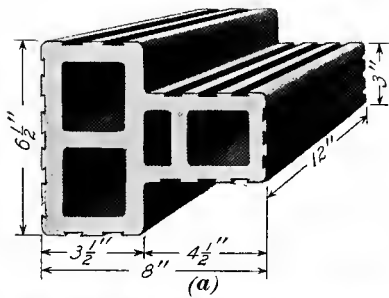



the tile. This tile must be grooved if it is to be plastered, as plaster or mortar will not adhere strongly to a glazed surface.

**15. Vitrified terra cotta** is generally made of fireclay or shale and is burned at a high temperature so that the material begins to fuse and is extremely hard throughout. This form of terra cotta is the densest kind, and is used for silos and other buildings in which the surface of the tile is exposed directly to the weather.

---

### SHAPES AND KINDS OF HOLLOW TILE

**16. Forms of Hollow Tile.**—Hollow tiles used for the erection of the walls of buildings are made in three different general forms. These forms are shown in Fig. 1. In (a) is a T-shaped tile, known as an *interlocking tile*; in (b) an H-shaped tile, known as a *load-bearing tile*; and in (c) a regular, or box-shaped, tile. All these forms consist of units of burnt clay having outer shells and thin partitions, or *webs*, which divide the blocks into *cells*. These webs are shown at *a*, and the cells at *b* in (c). The shells are about  $\frac{3}{4}$  inch and the webs about  $\frac{5}{8}$  inch in thickness.

---

### REGULAR, OR BOX-SHAPED, TILE

**17. Description of Regular Tile.**—In Fig. 2 are shown illustrations of some of the forms in which regular tiles are made. The blocks shown at (a) and (b) are used for closers and face blocks, as will be shown later on. Those at (c) and (d) are for building straight walls of different thicknesses. The blocks shown at (e), (f), (g), and (h) are modified forms of these regular blocks and are manufactured by the National Fire Proofing Company. They are known by the name of *Natco* hollow tile. Fig. 1 (c) is an illustration of a standard *Natco* block, showing in detail the arrangement of webs and the dovetailed scorings which are designed to afford a good grip for mortar and stucco.

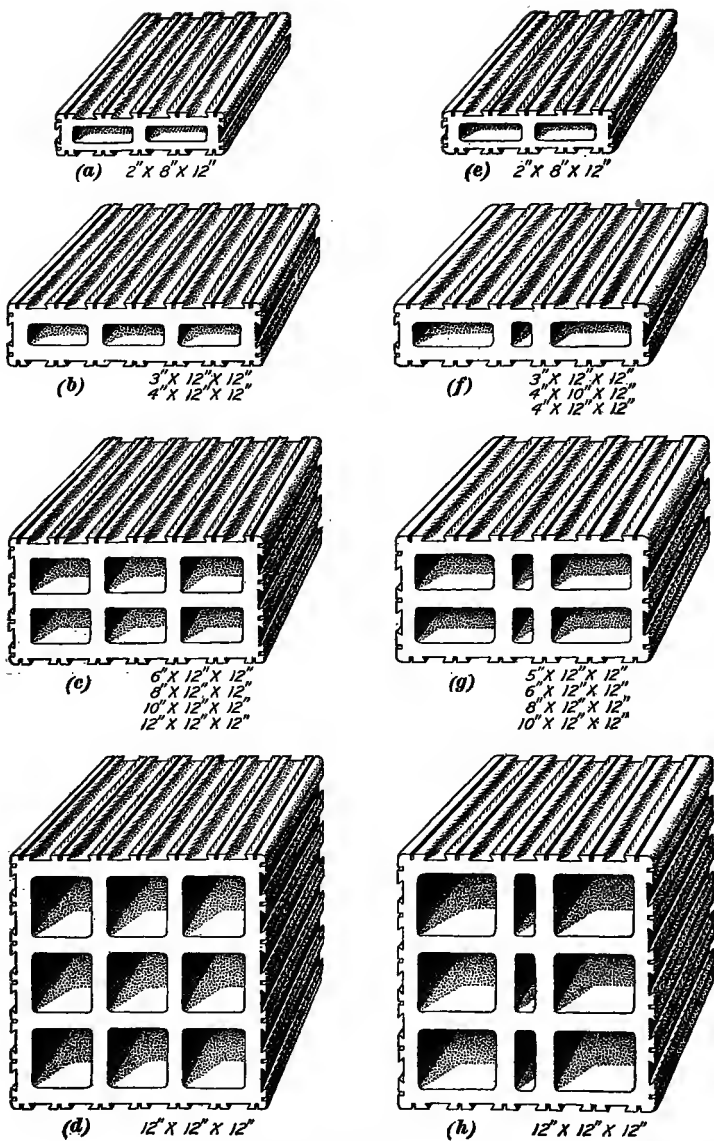

FIG. 2

By special arrangement of the webs and cells which is shown in Fig. 1 (c) and in Fig. 2 (g) and (h), the webs of the block above always rest directly upon the webs of the block beneath

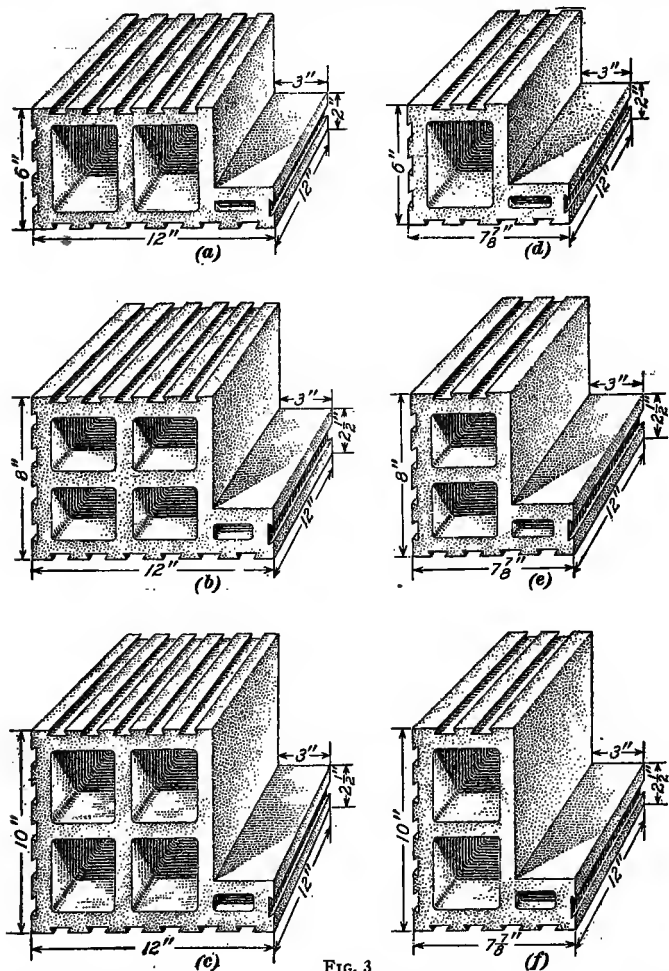

FIG. 3

when the joints are broken. The load on the tile is thus carried down to the ground by continuous webs of solid terra cotta. This also brings the cells into a continuous line from the top to the bottom of the wall so that they are available as pipe chases.

In Figs. 3 and 4 are shown jamb blocks and half jamb blocks, which are used for the jambs or sides of window openings when box window frames are used. In Fig. 3 are those that are used in connection with the regular blocks, and in Fig. 4

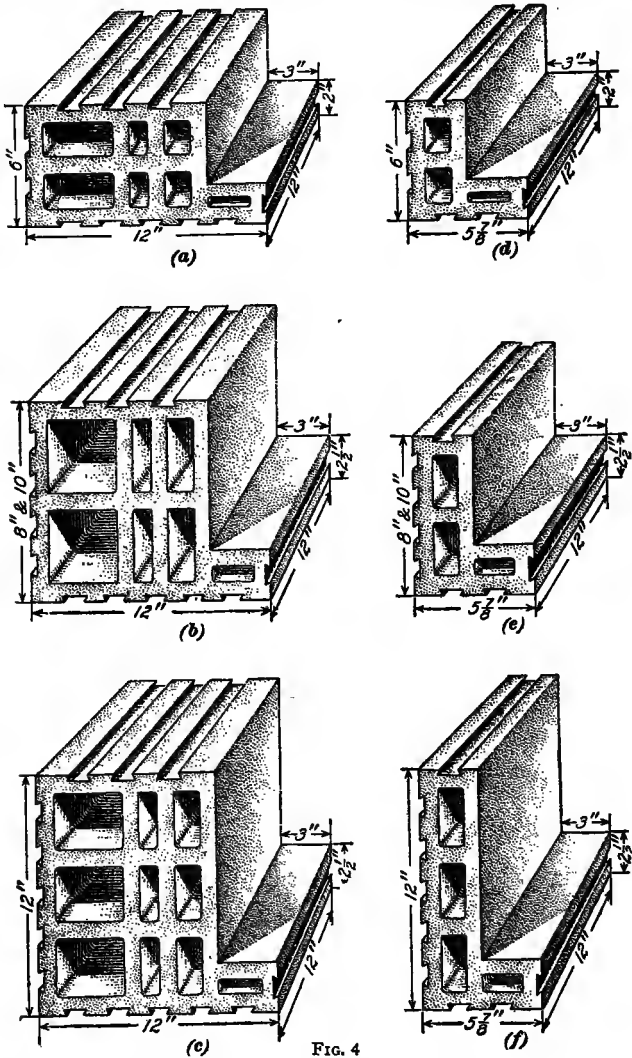

FIG. 4

ings when box window frames are used. In Fig. 3 are those that are used in connection with the regular blocks, and in Fig. 4

are similar blocks that are used in connection with the Natco blocks.

18. In Fig. 5 are shown box-shaped hollow tiles, made by the National Fire Proofing Company, which possess features that differ from those of the blocks already mentioned. For instance, these blocks are 5 inches in height instead of 12 inches and have double shells on the outer and inner faces

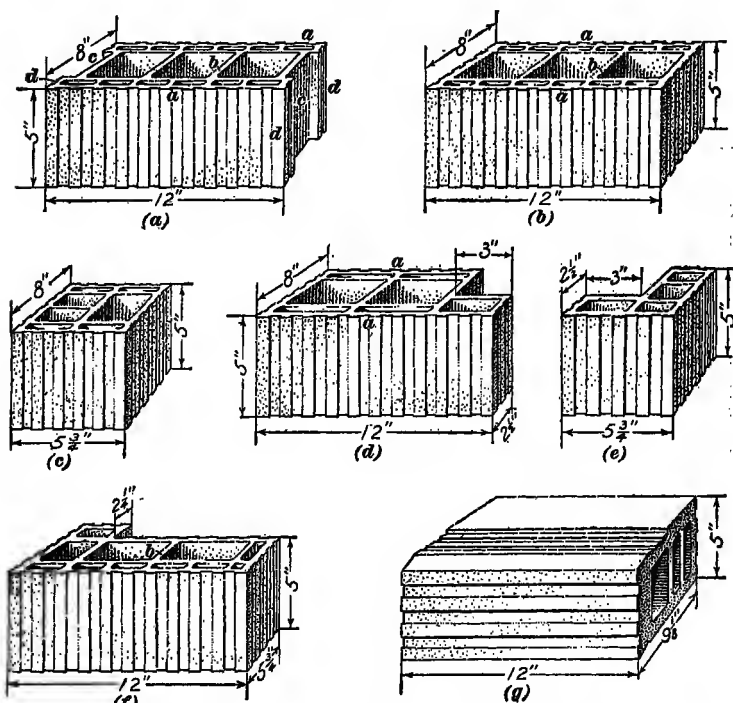

FIG. 5

of the principal blocks as shown at *a* in the different views in the figure. The cross webs *b* serve to tie the two faces *a*, *a* together, as shown in (*a*), rather than to support loads. Another feature that is different is the formation of the ends of the wall blocks (*a*). They are made with a hollow space *c* at each end so that the mortar joint does not extend through the wall but is placed on the surfaces *d* only. When the blocks

are set in place together this hollow space breaks the continuity of the mortar joint.

In Fig. 5 (a) is shown a standard wall block, in (b) and (c) *closure* tiles, or *closers*, for closing the ends of the cells in the tile at the end of a wall or at a door jamb. Jamb tiles and half jamb tiles are illustrated in (d) and (e), a corner block is shown in (f), and a sill block in (g).

Fig. 6 (a) shows a section taken vertically through several of these wall blocks, in which the double shells are at *b, b* and the webs at *a, a*. The mortar *c* is placed between the double shells only, and not between the webs at *d*. This breaks the continuity of these mortar

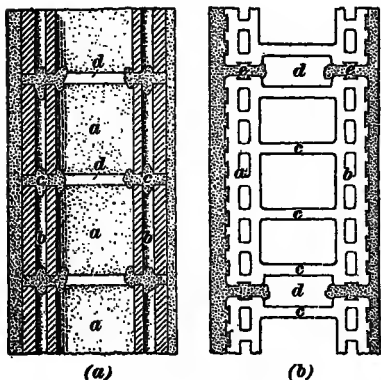

FIG. 6

joints. In (b) is a plan, in which the double shells are shown at *a* and *b* and the vertical webs at *c*. The air spaces between the ends of the blocks are at *d, d*, and the mortar joints between the ends of the tiles are at *e, e*.

**19.** The bulk of the wall, when regular tile is used, is composed of standard units, each consisting of a cellular

block of tile,  $8'' \times 12'' \times 12''$  tile being used for an 8-inch wall,  $10'' \times 12'' \times 12''$  for a 10-inch wall, and  $12'' \times 12'' \times 12''$  for a 12-inch wall.

Units of different thicknesses are often used in the same structure, since it is often desirable to make the wall in one portion of a building thinner than in some other portion, the upper walls of a building often being made thinner than the lower ones.

**20. Method of Setting.**—The regular, or box-shaped, forms of tile are generally set with the webs and cells in a vertical position so that the edges of the blocks are over each other on the outside and inside faces of the wall. The blocks



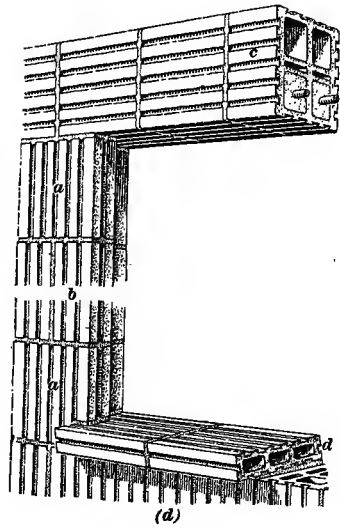
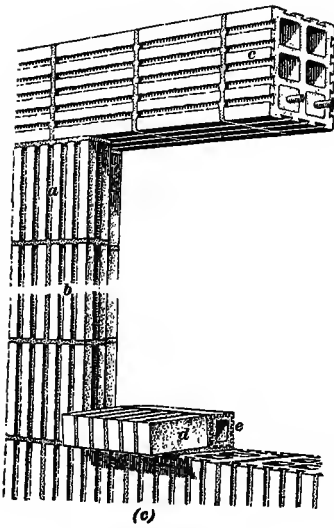
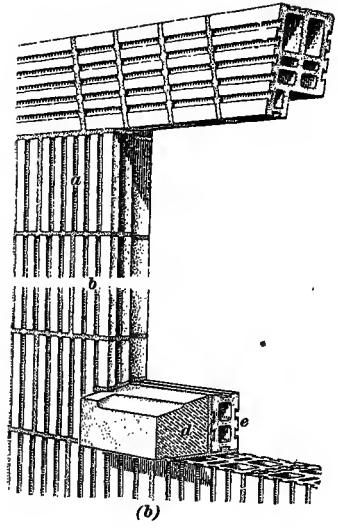
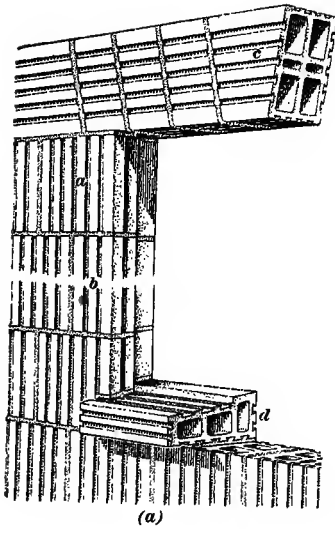

FIG. 7

are staggered over those below; that is, the vertical joint between two blocks is over the middle of the block below.

These tiles, set with the cells vertical, yield the maximum amount of strength. They are, however, sometimes set with the cells in a horizontal position, and for the ordinary loads that occur in dwellings, small factories, and other minor structures they are sufficiently strong when set that way.

**21.** The method of setting blocks with the cells vertical affords an easy means of forming chases for pipes and also allows of forming concrete piers beneath concentrated loads

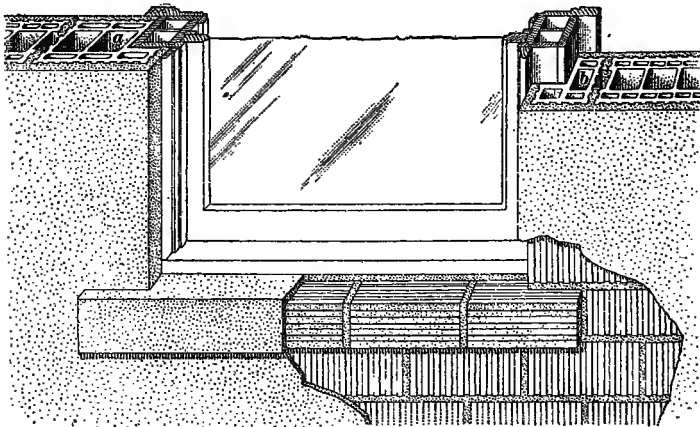

FIG. 8

that may occur in the structure. These concrete piers can be formed by simply filling a number of the cells below the special load with concrete, which sets and forms a strong vertical support, or pier.

Where the blocks are set with the cells in a horizontal position, it is difficult to cut chases and impossible to form special piers with concrete as just described. In such a case the chases must be formed as the wall is built, as will be described later.

**22. Special Shapes.**—There are several special shapes in hollow-tile blocks that are used in connection with the regu-

lar tile; some of these shapes are *jamb blocks*, *lintel blocks*, *sill blocks*, and *solid slabs*.

**23. Jamb Blocks.**—Jamb blocks, shown in Fig. 3, are used where box window frames are installed in a building. These blocks contain a rabbet into which the window frame is set. The use of jamb blocks and half jamb blocks is illustrated in Fig. 7, where at *a* are shown jamb blocks and at *b* half

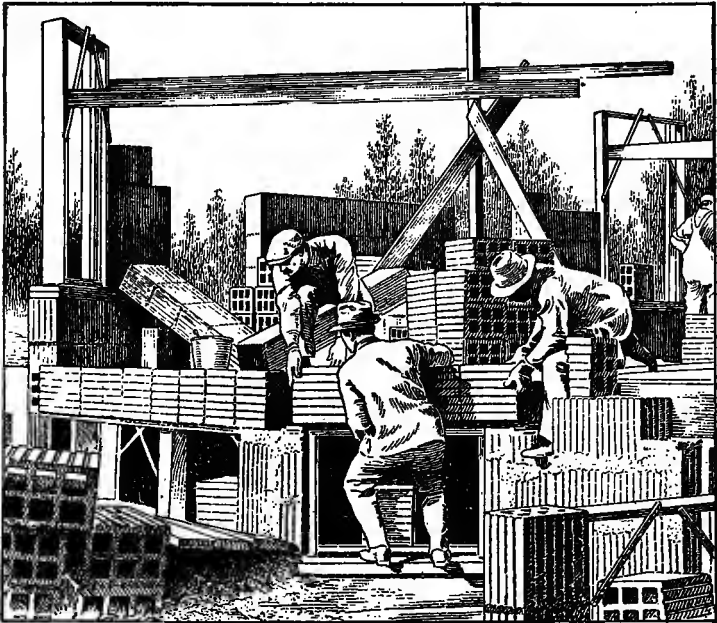

FIG. 9

jamb blocks, which are used alternately in the height of the wall in order that the wall blocks may break joints and also bond in strongly with the window jambs. Jamb blocks *a* and half jamb blocks *b*, for use in connection with the blocks shown in Fig. 5, are shown in Fig. 8.

**24. Lintel Blocks.**—Lintel blocks are used to form lintels over door and window openings that are not over 5 feet in width. One type of lintel block is made in the shape of a

vousoir, or arch stone, so as to form a flat arch as shown in Fig. 7 (a). Another form of block, shown in (b), also

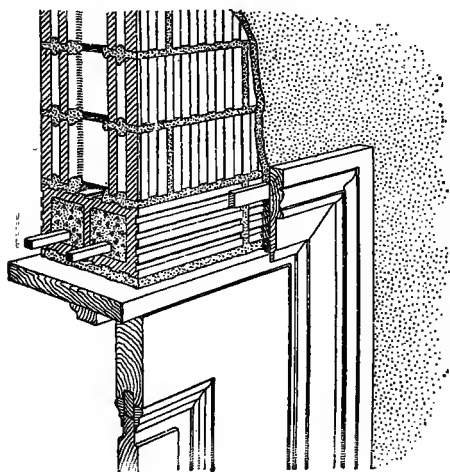

FIG. 10

forms a flat arch and has a rabbet *c* which is designed to receive the top of the window frame. The lintels most frequently used in practice are shown in (c) and (d), and consist of several standard blocks placed together as illustrated. These blocks are piled up on end, steel rods are placed in the cells that are to be the bottom ones when the lintel is in place, and these cells

are filled with concrete or strong mortar. The rods extend throughout the entire lintel and provide tensile strength for the bottom of the lintel. When the concrete or mortar has thoroughly set, the lintel may be lifted and set in place in the same manner as a stone lintel, as illustrated in Fig. 9.

A form of lintel used with the blocks shown in Fig. 5 is illustrated in Fig. 10.

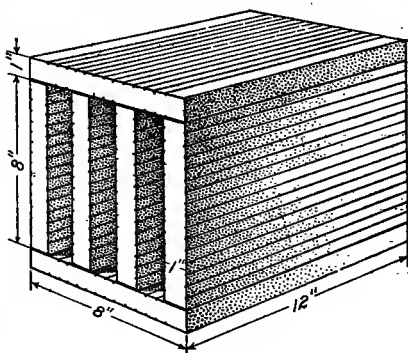

FIG. 11

## 25. Sill Blocks. —

Tile for window sills can be obtained in the form shown at *d* in Fig. 7 (a). This sill is made with a suitable wash and rabbet, and is grooved to hold a stucco coating. Another form of sill is shown at *d* in (d) and con-

sists of standard tiles 2 inches or 3 inches thick and laid either flat or with a slight slope. This sill is also designed to receive a coating of stucco. Other sills are used in connection with hollow-tile construction, such as the stone sill shown at *d* in (*b*) and the brick sill *d* in (*c*). The sill in (*c*) may be constructed of hollow terra-cotta tile of brick size, or of ordinary brick and covered with stucco; or it may be formed of face brick and show the brick surface on the finished sill. Stone or brick sills are sometimes backed with terra-cotta blocks, as shown at *e* in (*b*) and (*c*).

**26. Solid Slabs.**—Solid slabs, 1 inch in thickness, are made for use under beams. They are laid over the cells on top of the regular wall blocks to form a continuous bearing for floorbeams, as shown later. These slabs are delivered at the building in the form of boxes resembling the regular box tile, as shown in Fig. 11. When tapped on the corner, these blocks fall apart into 6 flat slabs. The sizes in which these slabs are made are 1 in.  $\times$  8 in.  $\times$  10 in.; 1 in.  $\times$  6 in.  $\times$  12 in.; and 1 in.  $\times$  8 in.  $\times$  12 in.

---

### T-SHAPED TILE

**27. Form and Use.**—As indicated by the name, T-shaped tiles have a shape similar to that of the capital letter **T**, as is shown in Fig. 1 (*a*) and also in Fig. 12. This type of tile is laid with the cells in a horizontal position.

The particular advantages claimed for the T-shaped tile are, first, that the shape of the tile breaks the direct mortar joint between the outside and inside surfaces of the wall. This will be seen in Fig. 12, where in (*a*) is shown an 8-inch wall, in (*b*) a 12-inch wall, and in (*c*) a 16-inch wall. In all these walls it will be seen that the mortar joints *a* are interrupted by the air spaces *b*, so that moisture cannot penetrate through the wall by way of the mortar joints.

The second advantage claimed is that no air space in one course of tile communicates with air spaces in the next course above or below, hence there is less circulation of air than when the cells are placed vertically.

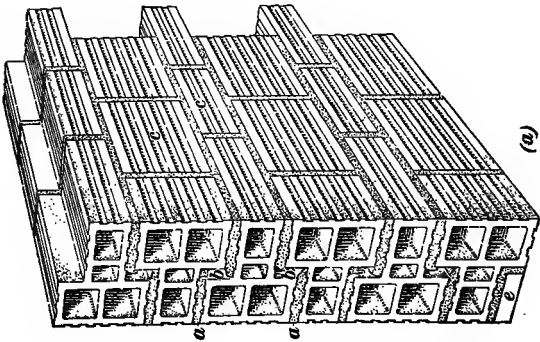
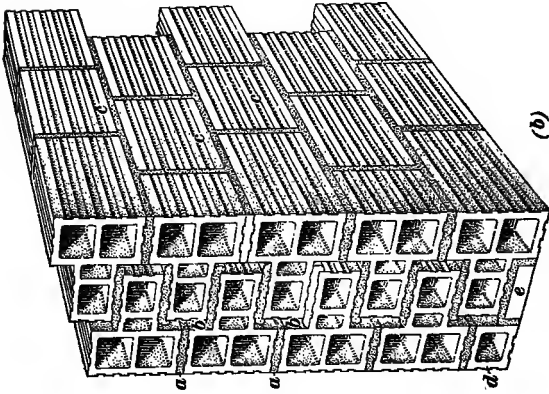
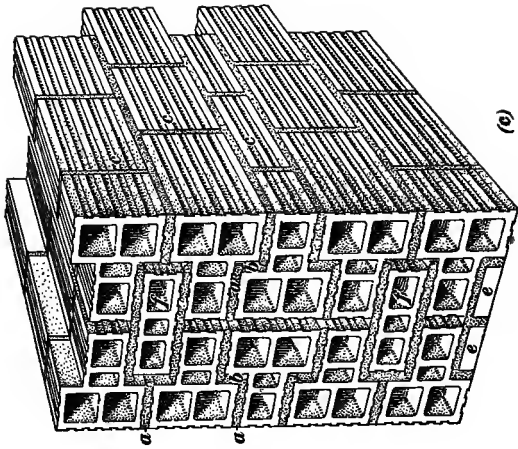

FIG. 12

As in the regular tile, the webs come directly over each other, thus forming continuous webs that carry down the loads supported by the wall to the footings under the wall.

In laying these blocks, the joints are staggered or broken, as shown at *c*, as is done in laying the regular blocks. In Fig. 1

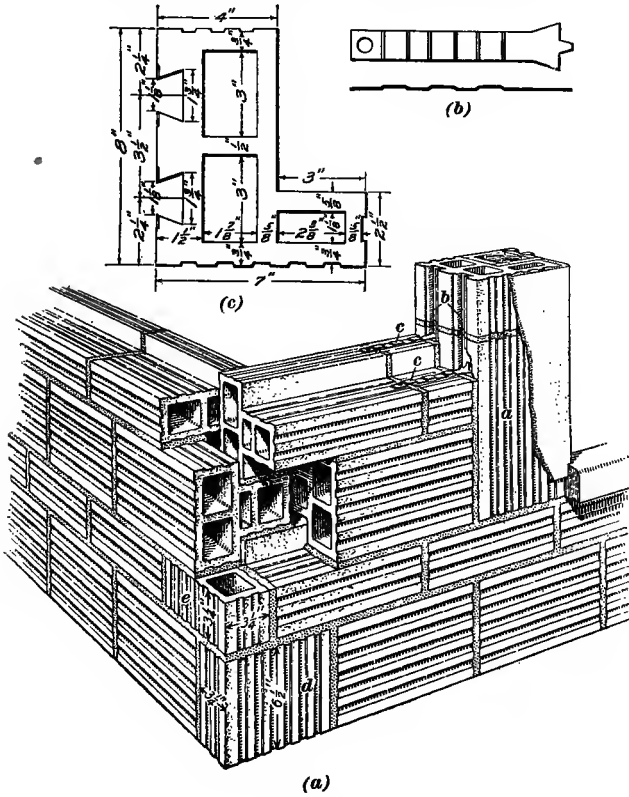

FIG. 13

(a) is shown a T tile with the standard dimensions. The standard tile is 12 inches in length, but some of the blocks are scored or indented so that they can be easily broken into 4-inch and 8-inch lengths when desired. This does away with the necessity of purchasing extra shapes for places in the wall where these shorter lengths are required.

**28. Special Shapes.**—As in the case of the regular tile, special forms or shapes are required when using T-shaped tile for the jambs of windows, where box frames are used, as well as for sills, lintels, corners, starting blocks, etc.

**29. Jamb Tile.**—The form of tile used for jambs in connection with T tile is shown at *a* in Fig. 13 (*a*). The large dovetail grooves *b* in the wall side of this tile are for the reception of steel anchors *c* which fit into the grooves as shown in

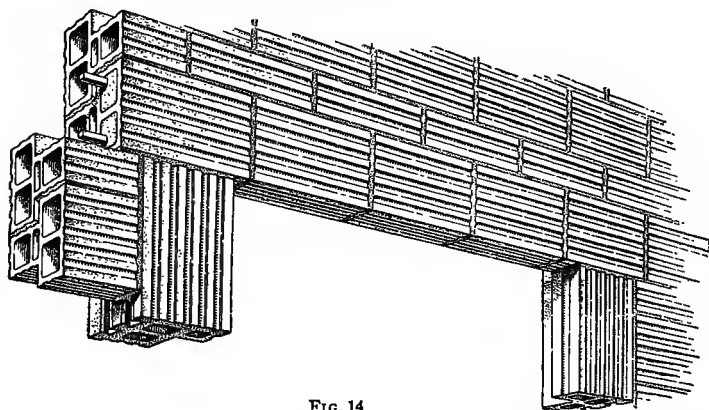

FIG. 14

the figure and tie the jamb blocks firmly to the wall. In (*b*) is shown a plan of one of these anchors. A plan of the jamb block is shown in (*c*).

**30. Lintels.**—Lintels are formed by piling the required number of wall tiles on end and filling the cells with concrete, steel bars first being placed in the cells that are to be the upper and the lower cells when the lintel is in place. When the concrete has set, these lintels are set in place in the same manner as stone lintels. It is not safe to use a lintel of this type for an opening more than 5 feet in width. An illustration of a lintel formed of T-shaped tile is given in Fig. 14.

**31. Chases.**—In walls, vertical chases for the accommodation of soil and steam pipes, etc. are made in the form shown



in Fig. 15, by using the standard T tile as far as possible and filling in with pieces of tile obtained by cutting the standard tile or with bricks. In (a) is shown a chase in an 8-inch wall, and in (b) a chase in a 12-inch wall. These chases are covered with wire lath as shown in (b), and the plastering is continued across the chase opening.

### 32. Corner Tile.

In building a wall of standard T tile there will always be certain spaces left at the corners of the wall that will require special-shaped tiles to fill them out properly. In Fig. 13 (a) is an 8-inch wall which shows the spaces left to be filled with special corner tiles after the regular T blocks have been used as far as possible. The blocks *d* and *e* in (a) represent the corner blocks required for this purpose. The smaller block *e* is merely one-half of a block such as *d*. The blocks *d* are  $6\frac{1}{2}$  inches high and are scored or

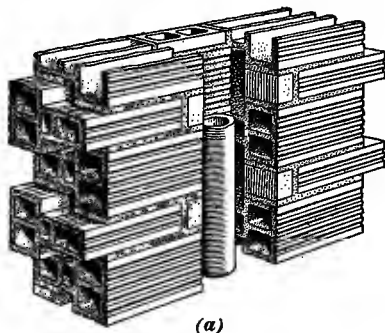

(a)

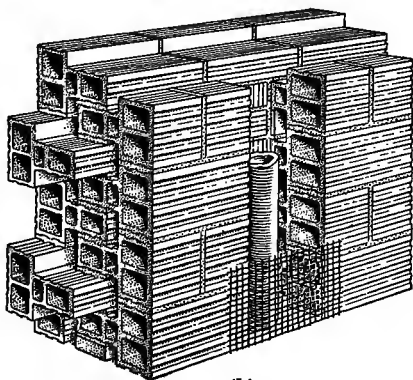

(b)

FIG. 15

marked so as to be broken easily into two  $3\frac{1}{4}$ -inch blocks when required. For 12-inch walls the same corner block as at *d* is used, as shown in Fig. 16 at *a* and *b*. These blocks are  $6\frac{1}{2}$  inches in height and are used in both positions.

**33. Starting Blocks.**—It is necessary in starting a T-tile wall upon a level surface to use starting blocks as shown at *d*

and *e* in Fig. 12. The block *d* is a one-celled block while *e* is a solid piece of terra cotta or brick.

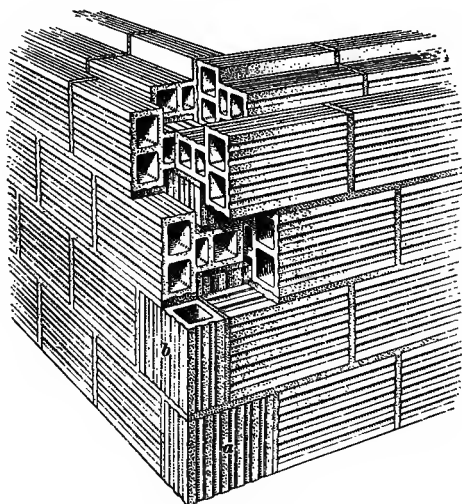

FIG. 16

**34. Bonding Tile.**—A special tile, shown at *f* in Fig. 12 (*c*), is required for walls 16 inches or more in thickness to complete the bond properly.

### H-SHAPED TILE

**35. Form and Use.**—H-shaped tiles are also usually laid with the cells in a horizontal position, and the same advantages are claimed for them as for T-shaped tile. The H-shaped tile is illustrated in Fig. 17. At *a* in (*a*) is shown an  $8\frac{1}{4}'' \times 10\frac{1}{4}'' \times 12''$  block. The height of this block,  $10\frac{1}{4}$  inches, is the same as that of four bricks and three mortar joints; the block shown in (*b*) is  $7\frac{5}{8}$  inches, or three bricks and two mortar joints, in height; that shown in (*d*) is  $8\frac{1}{4}$  in.  $\times 5\frac{1}{8}$  in.  $\times 12$  in., or two bricks and one mortar joint in height. The block shown in (*c*) is about the size of a common brick but 12 inches in length.

The slots in the tops and bottoms of these blocks serve to break the mortar joint so that it will not be continuous through the wall. This is shown in (a) and (b).

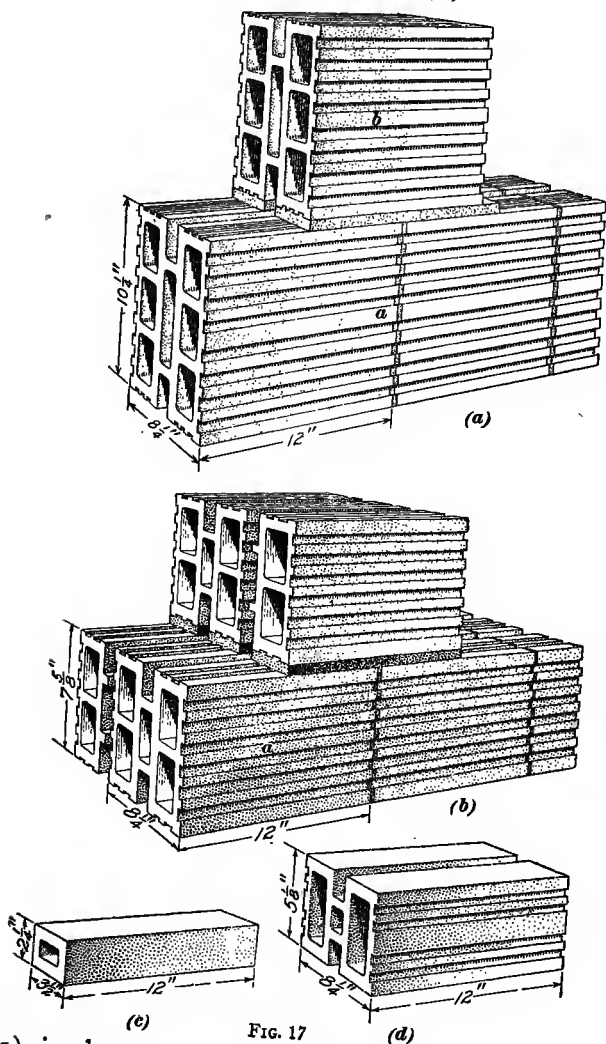

FIG. 17

In (a) is shown the method of laying the blocks in an 8 1/4-inch wall and in (b) in a 13-inch wall.

**H** blocks have four heavy vertical webs which come above each other in the successive layers of blocks and thus form continuous webs from the foundation to the top of the wall. The surfaces of these blocks are finished with deep grooved scoring, scratched scoring, or smooth.

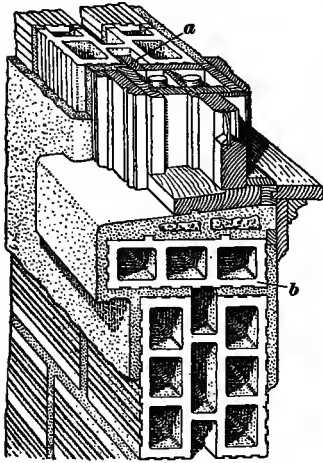

FIG. 18

**36. Jamb Tile.**—Jamb tiles may be formed by standing the regular **H** tiles with the cells vertical. A strip of wood is secured to the window frame and extends into the groove in the tile as shown at *a* in Fig. 18. This strip acts as a wind stop and also prevents the frame from falling out of the wall.

A special jamb block is made with full-size blocks as shown at *a*, Fig. 19, and half blocks *b*

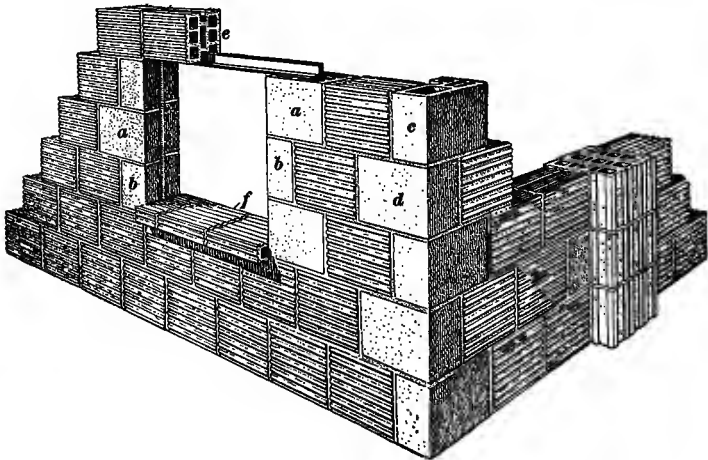

FIG. 19

which are used alternately in the height of the jamb. This block is also shown in plan in Fig. 20 (*a*).

A third kind of jamb block is formed by cutting away a portion of the regular block so as to form a rabbet, as shown in (b), Fig. 20.

**37. Sill Tile.**—For sills a three-celled block made by cutting a standard H block in two, is used as shown in Fig. 18 at b and in Fig. 19 at f. Brick or stone may also be used as with the regular tile.

**38. Corner Blocks.**—A special corner block shown at c, Fig. 19, is used to complete the corners of walls laid up with H tile. The application of this corner block is shown at e and d.

### 39. Lintels.

Lintels may be made with H tile in exactly the same manner as those in the regular block by piling up a sufficient number of blocks on end, inserting steel rods in the cells that will be at the bottom of the lintel when it is in place, and filling these with concrete. Lintels are also formed as shown in Fig. 19 at e by placing two steel angles back to back and setting standard tile on top of them.

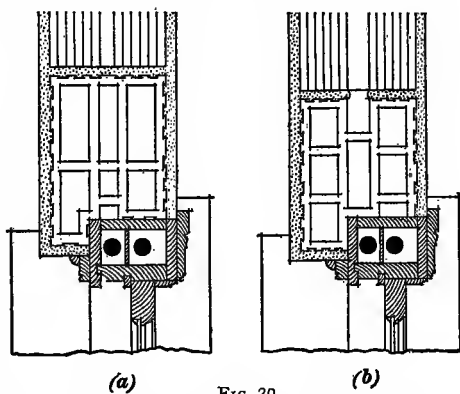

FIG. 20

## SPECIAL TILE

**40. Backup Tile.**—A special type of hollow tile, called *backup* tile, is manufactured for use in backing up brick veneering. By its use a lighter wall can be built than would result if common brick were used for that purpose and one that is sufficiently strong to support the loads that are met with in moderate-sized buildings. Backup tiles are made 5 inches, or two courses of brick, in height, and are either 4 in.  $\times$  12 in.

or 8 in.  $\times$  12 in. in horizontal dimensions, so as to form either a 9-inch or a 13-inch wall with the brick veneering. The use of this form of tile is discussed later on in this Section and is illustrated in Fig. 38.

**41. Silo Blocks.**—Special hollow-tile blocks manufactured for the purpose of building silos are illustrated in Fig. 21.

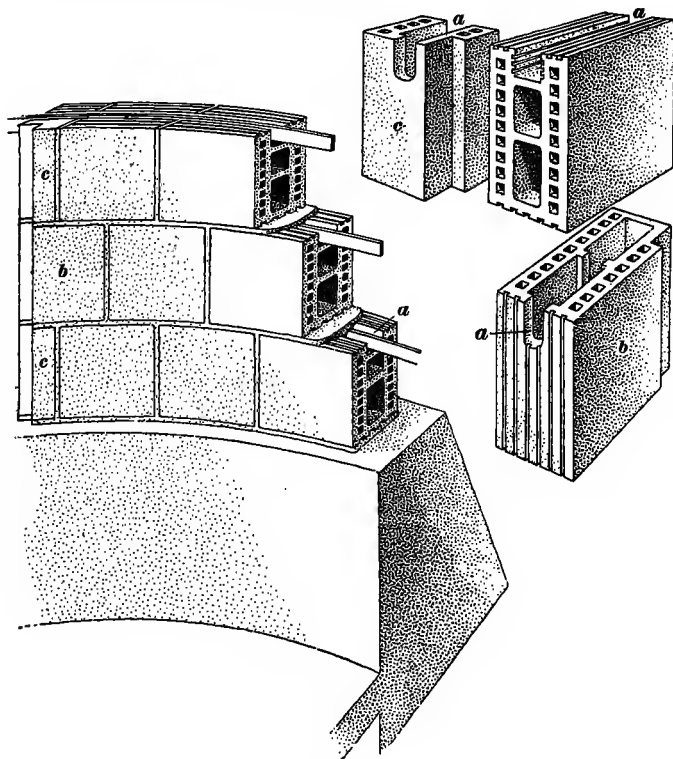
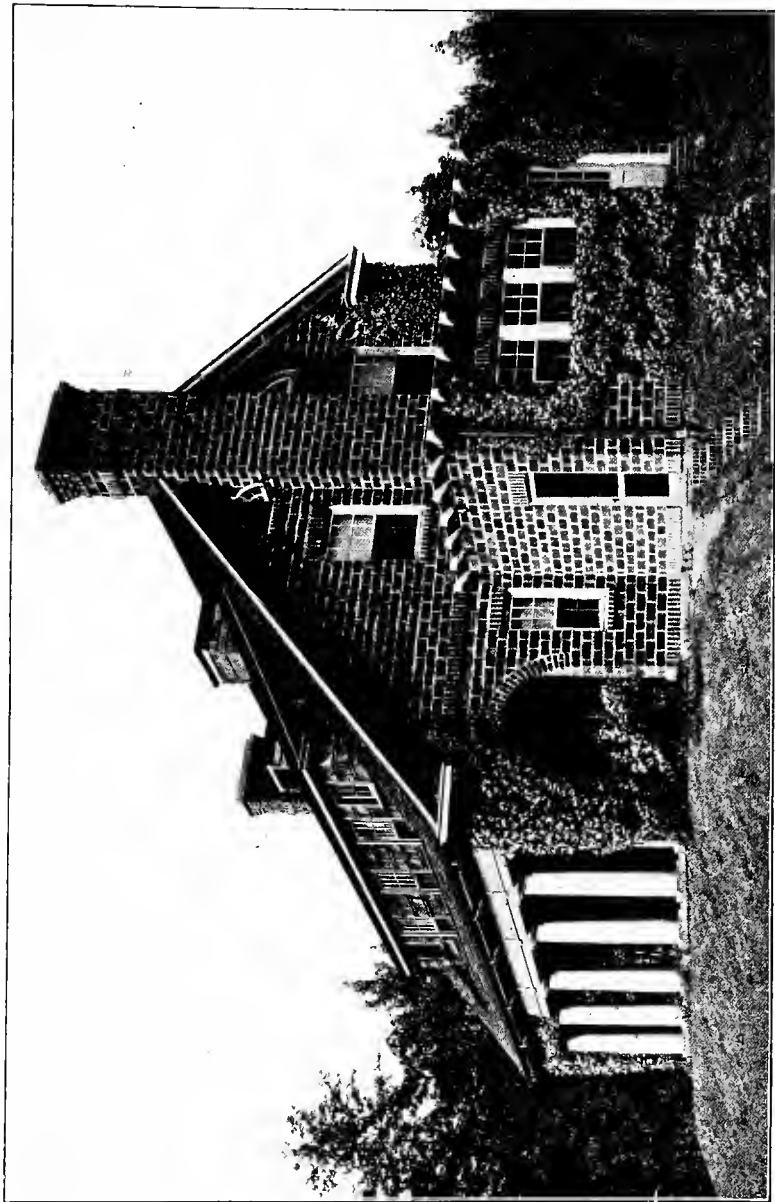

FIG. 21

The blocks are molded to a radius according to the diameter of the silo, and grooves *a* are formed in their upper edges into which iron or steel bands are set. The grooves are then filled with mortar. The purpose of the bands is to prevent the bursting of the silo which might be caused by the pressure of its



*Courtesy of National Fire Proofing Co., Pittsburgh, Pa.*

FIG. 22

contents. Hollow-tile blocks with which certain standard sizes of silos can be built are kept in stock by manufacturers, and promptness in delivery of the material can be obtained by ordering silos of such sizes.

The blocks are made of vitrified clay, which is fireclay or shale that has been burned until it has become vitrified. They are therefore very durable and are not porous. The size of the regular silo block is 6 inches thick and 12 in.  $\times$  12 in. on the outer face. Where the doors to the silo occur, special jamb tiles *b* and the half jamb tiles *c* are used.

**42. Textile.**—*Textile* is a form of hollow tile that combines the features of the hollow-tile blocks with those of face brick. The Textile block is a hollow-tile block in which the exposed faces are finished like a rough face brick. A wall built of these blocks has the advantage of being hollow and of having the color and texture of rough face brick where exposed on the outside. The exterior effect of this wall is distinctive, as the faces of the Textile blocks showing in the face of the wall are about three times the size of a standard brick, or about 12 in.  $\times$  5 in. The wall has the appearance of having been built of very large bricks, which gives it a peculiar attractiveness. Fig. 22 shows a charming house, built of Natco Textile blocks, which illustrates the effect of this unit. In contrast with the Textile blocks, the string-course, lintels, sills, and the arch, are built of standard-sized brick, which emphasize the size of the Textile block.

Fig. 23 shows a few of the standard Textile blocks. They are used in practically the same manner as other hollow-tile blocks. In (*a*) is a regular block for use in the body of the wall. The face *a* is finished like the surface of a face brick. The back of the block *b* is grooved to afford a firm grip for plaster. These blocks are placed with the cells in a vertical position. In (*b*) is shown a lintel block made by placing two, three, or more special blocks together end to end, inserting rods *b*, and filling the middle cells *a* with concrete. When the concrete has set, a lintel is formed similar to those made for regular tile and is set in place in a similar manner.



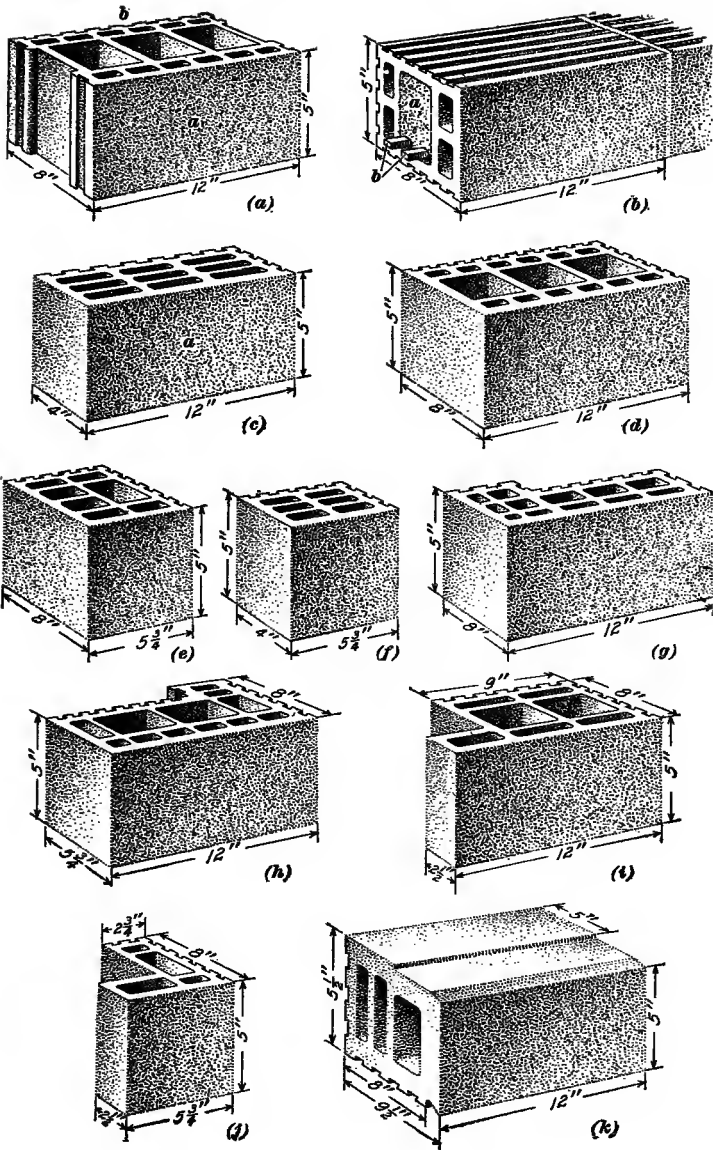

FIG. 23

In (c), (d), (e), and (f) are shown closures used in finishing jambs or sides of other openings in the tile wall that do not require to be rabbeted. Corner blocks are shown at (g) and (h), and jamb tiles at (i) and (j). A sill block is illustrated at (k). These various blocks are used in a similar manner to those already shown in the standard T-shaped and H-shaped tile. A study of the building shown in Fig. 22 will give a good idea of the method of using Textile blocks.

The shapes of these blocks are similar to those shown in Fig. 5, the difference being in the treatment of the outer face.

### SURFACES OF TILE

**43. Surface Treatment.**—In addition to variations in shape or form, and in density, tile vary in the treatment given to their surfaces. These surfaces are formed according to the purpose for which the tile is to be used.

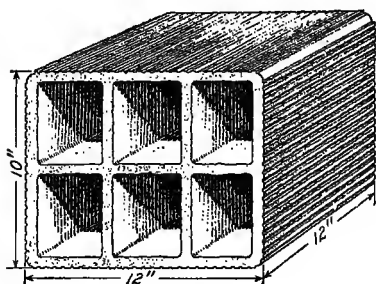

FIG. 24

The principal surfaces made on hollow tile blocks are *smooth*, *scratched*, *scored*, and *special* surfaces.

**44. Smooth Surfaces.** Smooth-surfaced tile is, as the term indicates, entirely smooth, and is used most

often in building factories or warehouses where the tile is to be left in its natural state, uncovered by other materials such as stucco or face brick. Tiles are frequently made so as to present a smooth surface on one side only and are scratched or scored on the remaining surfaces. The smooth surface in this case is exposed.

**45. Scratched Surface.**—Scratched-surface tile is tile having its surface scratched as shown in Fig. 24 so that plaster and stucco will adhere to it more strongly. This surface is used also in walls that are to be faced with brick. Scratched-

surface tile is now so universally manufactured that it has become a standard type.

**46. Scored Surface.**—The scored surface is an exaggeration of the scratched surface and was designed primarily for walls that were to be plastered, the deep grooves providing an effective mechanical bond between the tile and the plaster. This style of surface is illustrated in Fig. 1. The scorings sometimes are plain rectangular depressions in the surface of the tile, and in other cases are dovetailed. The scored surface has also become a standard one, as it costs little or no more to manufacture than the scratched surface and forms an excellent bond not only for the stucco and plaster but for the mortar joints.

**47. Special Surfaces.**—Tiles are made with special finishes on the outside and inside for use where they are exposed on the finished surface of buildings and where ordinary smooth tile is not sufficiently attractive in appearance. These finishes are similar to those used on the surfaces of fine face bricks, and are used on the Textile blocks already described.

---

### STRENGTH OF TILE

**48.** The strength of tile that is of interest to those using it in building is the compressive strength, or strength to resist crushing. This naturally varies with the hardness of the tile. The tile ordinarily used for wall blocks of any shape has a strength of about 5,000 pounds per square inch. This is the ultimate compressive or crushing strength. In practice only a fraction of this strength is estimated upon or employed, generally not more than one-sixth or one-eighth.

**49.** The building laws of Chicago require that the tile be “hard-burned terra-cotta tile of uniform quality, free from shrinkage cracks, with true beds, and having an ultimate compressive strength of not less than 4,000 pounds per square inch.” The strength allowed in actual use is 500 pounds per square inch, or  $\frac{1}{8}$  the ultimate compressive strength. These

figures refer to the actual terra-cotta material under compression, without regard to the cells.

**50.** The New York City building code estimates the compressive strength of tile blocks for the total area of the block, including shell, webs, and cell spaces.

Thus, a block 10 in.  $\times$  12 in. in horizontal section is considered as having a section of 120 square inches, and when tested must show an ultimate crushing strength of not less than 1,200 pounds per square inch when the cells are placed vertically and 300 pounds per square inch when the cells are placed horizontally. Hence the block just mentioned should show an ultimate strength of  $120 \times 1,200 = 144,000$  pounds for the entire block, with cells vertical; or  $120 \times 300 = 36,000$  pounds with cells horizontal.

The safe carrying capacity allowed by this code is 100 pounds per square inch with cells vertical, and 50 pounds per square inch with cells horizontal.

---

## USES OF HOLLOW TERRA-COTTA TILE

**51. Various Uses of Hollow Tile.**—Hollow tile in its various forms is used for erecting walls, partitions, piers, columns, floors, and roofs, especially when a fireproof construction is desired. The form of hollow tile here under consideration is that which is designed for building exterior walls to support floors and roofs. Tiles for this purpose are designed with strong vertical webs for supporting such loads, and may be used in conjunction with fireproof floors of terra cotta or used in connection with floors of wooden construction such as those in frame houses.

**52. Choice of Tile.**—As in the case of other building materials, architects and contractors have their preferences for certain kinds of tile or tile construction, and it is well to be familiar with all the best kinds of tile and their uses so as to be able to choose intelligently among them. Excellent buildings have been erected by using each of the different kinds of tile on the market and by following the methods recommended

by tile manufacturers. The selection depends upon the tile that can be delivered most promptly or which is the best or the cheapest.

### FOUNDATIONS OF HOLLOW TILE

**53.** In many buildings hollow tile is used for the foundation walls. When used for this purpose the tile should be vitrified or glazed, as ordinary hollow tile such as is used for walls above ground will disintegrate in time if placed underground. In this respect it is like common brick, which is not

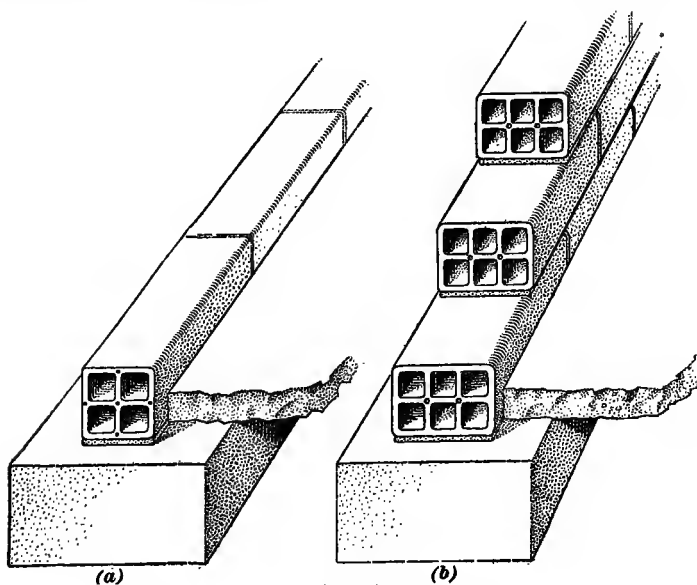

FIG. 25

the best material to use below the surface of the ground unless very hard burned or vitrified.

**54. Dense-Tile Foundations.**—Dense tile is used for foundations, but when so used it is advisable to protect it from dampness by coating the exterior of the wall with some waterproofing compound such as asphaltum or coal-tar pitch. Another way of protecting this kind of tile is to give the outer

surface of the walls a good coat of Portland cement stucco or plaster as is done in the case of brick foundations. The plaster should be composed of a mixture of 1 part Portland cement and 1 part sand, with not more than  $\frac{1}{10}$  of a part of hydrated lime added.

#### **55. Telephone-Conduit Tile for Foundations.**

When it is desired to use foundations of hollow tile, ordinary telephone-conduit tile will be found to be very satisfactory both as to endurance and economy. This kind of tile is used for underground conduits by the telephone companies. The tiles are 9 in.  $\times$  9 in. and 9 in.  $\times$  13 in. in cross dimensions, and 18 inches to 36 inches in length. They are illustrated in Fig. 25. The 9"  $\times$  9" tiles laid flat form a wall 9 inches in thickness as shown in (a), and the 9"  $\times$  13" tiles form a 13-inch wall, shown in (b). The larger units contain 6 cells and the smaller units 4 cells. This material will be found strong enough to sustain the ordinary loads of a dwelling house or other small building. Conduit tile is glazed, presenting the same texture as ordinary glazed sewer pipe, and will last for an indefinite length of time underground.

**56.** Telephone-conduit seconds are conduit tile with slight imperfections in finish, such as blisters or broken edges, and are often slightly warped. They are not satisfactory for the purposes of telephone conduits, but are perfectly useful for building foundation walls below grade. They are also much cheaper than perfect conduits, thus making them economical to use as foundation material.

**57. Laying Conduit Foundations.**—Telephone-conduit tile should be laid in full beds of cement mortar, and any corners that are broken should be patched with mortar. At the corners of the wall where the openings of the cells appear on the face of the wall, the ends of the cells should be closed up with brickbats and mortar.

**58. Building-Code Restrictions.**—The building laws of some cities make restrictions as to the use of terra-cotta hollow tile for foundations. Thus, the building code of New

York City specifies that hollow blocks may be used for foundation walls only when the upper walls are of frame or hollow building-block construction; also that the hollow spaces in the blocks shall be filled, as the construction progresses, with concrete consisting of not less than 1 part of cement to 9 parts of aggregate. Other cities require that buildings erected with hollow terra-cotta tile walls shall not be over four stories in height.

#### **59. Other Foundations Used With Hollow Tile.**

In many sections of the country, cement concrete, concrete blocks, and stone are of no greater expense than hollow tile and are consequently used for foundations instead of hollow tile, even though the upper walls are to be built of tile.

In a house or small building, where the exterior walls above grade are to be 12 inches in thickness, a 12-inch foundation of concrete blocks or of solid concrete is usually sufficient.

Where the upper exterior walls are of 8-inch tile, a 12-inch foundation wall should be used. These thicknesses are for cellar walls that extend 6 or 8 feet into the ground.

---

### **EXTERIOR WALLS OF HOLLOW TILE**

---

#### **WALLS OF REGULAR, OR BOX-SHAPED, TILE**

**60. Wall Construction.**—Illustrations of the individual tiles of box shape used in building walls have been shown in Figs. 1 (*c*), 2, 5, etc. Walls can be built of these blocks in various thicknesses, such as 6 inches, 8 inches, 10 inches, and 12 inches, by making the walls one block in thickness, as illustrated in Fig. 26 (*a*), (*b*), and (*c*). Thicker walls, which, however, are rarely called for, can be formed by combining these units in different ways so as to provide a sufficient bond, as shown in Fig. 26 (*d*). These blocks have a uniform height of 12 inches, but blocks of different sizes can be supplied by the manufacturers if necessary, as where the heights of the different stories of the building do not work out evenly by the use of

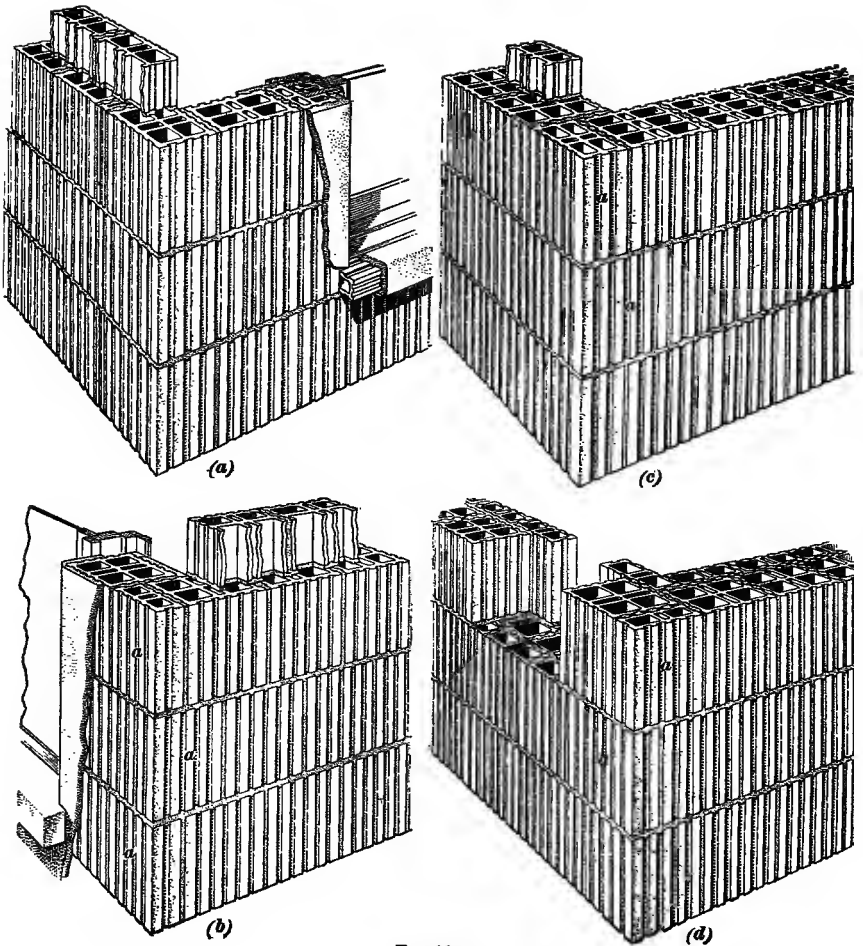

FIG. 26



blocks 12 inches high. It is an excellent plan when ordering hollow tile to send a set of plans to the manufacturer, who will then be able to ship exactly the right assortment of sizes of blocks.

As a wall is rarely required to have the same thickness for its whole height, the wall in the different stories can be made of different thicknesses. Thus, the cellar wall may be made 12 inches in thickness by using 12-inch blocks, and the first-story walls 8 inches thick by using 8-inch blocks. The second-story walls can be made 6 inches in thickness by using 6-inch blocks. •

The New York building code requires that where the walls are reduced in thickness, the blocks on the top course of the

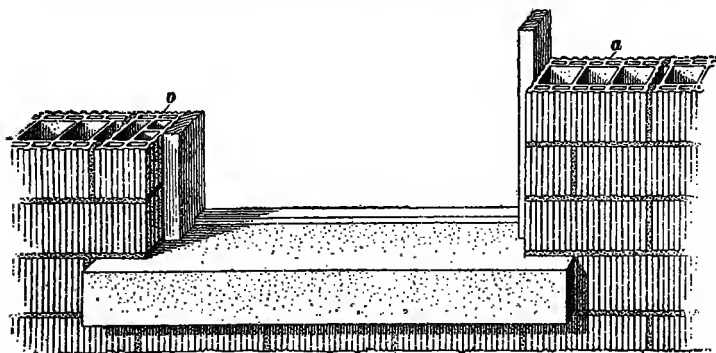

FIG. 27

thicker wall shall be filled solidly with concrete or covered with slabs of hard-burned terra cotta or concrete at least 1 inch in thickness.

**61.** Blocks of the kind shown in Fig. 5 are placed in a wall in the manner shown in Fig. 27, in which can be seen the construction around a door opening, a closure block being shown at *a* and a half closure block at *b*. A window opening is shown in Fig. 8 with a jamb tile at *a* and a half jamb tile at *b*; the construction of the sills is also shown. In Fig. 10 is shown a treatment for a lintel over a window opening.

**62. Bedding in Mortar.**—The bedding of tile, that is, the way in which tile blocks are set into the mortar, is a very

important feature of hollow-tile construction. Although different manufacturers claim that their particular forms of hollow tile offer advantages in bedding, bedding is really a matter of good workmanship. Any of the various patterns of tile that have already been described may be well laid if the workman understands the method and desires to do a good job. A good bed of mortar should always be placed beneath the

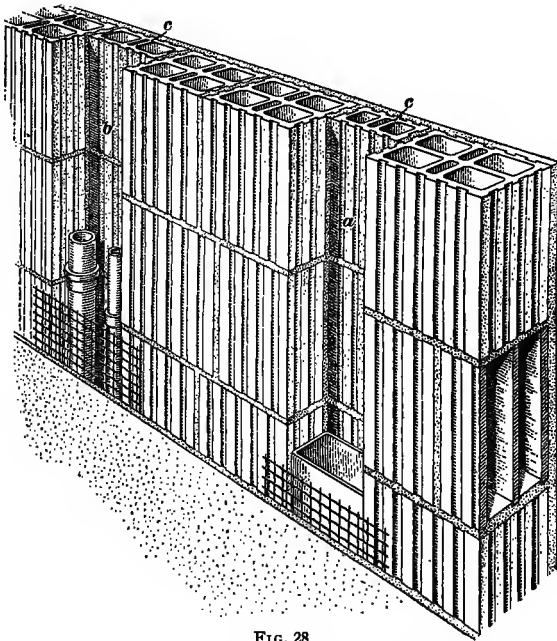
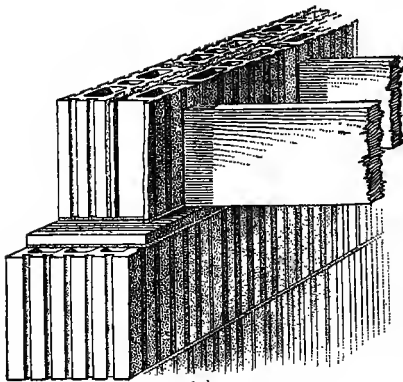

FIG. 28

bearing surfaces and in the vertical joints at both faces, but it is also desirable that the mortar joints should not be continuous through the thickness of the wall.

**63. Mortar.**—The best mortar to use in bedding hollow tile is a mortar made of 1 part Portland cement and 3 parts of clean sand to which  $\frac{1}{10}$  part hydrated lime may be added. The mortar should be made stiff enough to adhere readily to the thin edges of the tile.



(a)

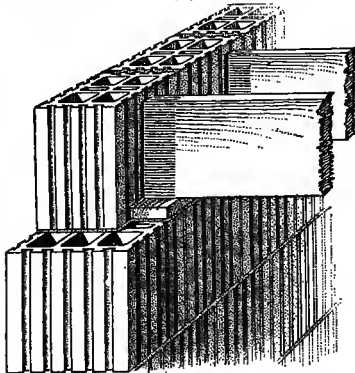

(b)

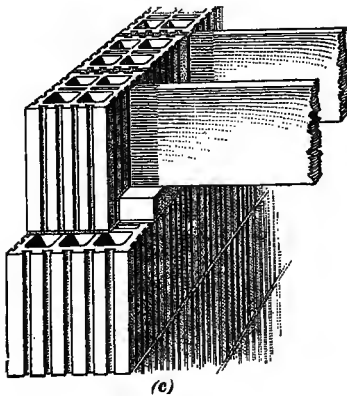

(c)

FIG. 29

#### 64. Cutting Tile.

Terra-cotta tile can easily be broken with a mason's trowel or a hammer in the same manner as brick is broken. It can, therefore, be cut to fit special positions where there are no stock tiles of the proper size and shape on hand.

**65. Chases.** — It is generally necessary to accommodate pipes, such as plumbing, heating, and gas pipes, as well as electric-wire conduits, within the thickness of the wall. Chases, or vertical recesses, must therefore be formed either by building recesses in the wall or cutting them in the wall after it is built. One of the advantages claimed for the regular tile is that chases can be cut wherever necessary after the wall is completed. It is not advisable, however, to allow the plumber, the gas-fitter, the heating contractor, and the electrician to hammer out chases in the wall wherever they may choose, hence it is better to build chases into the wall at properly designed points so as to accommodate all

the necessary pipes. Fig. 28 illustrates the method of building chases so that it will not be necessary to ruin the wall with a hammer. The wall at *a* and *b* is made thinner by using thinner blocks *c*, these blocks extending the full width of the chases. Over the chases, strips of wire lath are secured which close the chases entirely and afford a base to receive the plastering. Chase *a* accommodates a heating flue, and chase *b* a soil and a waste pipe.

**66. Corner Blocks.**—With the regular tile the problem of finishing the corners of a wall is easily solved by the use of regular stock blocks such as shown at *a* in Fig. 26 (*b*), (*c*), and (*d*), and the manufacturers generally send a sufficient quantity of these corner blocks to complete the wall. It is a great advantage to send a set of plans to the manufacturer when ordering, as he will then supply all the special pieces that may be needed to complete the job.

**67. Supports for Wooden Floorbeams on Regular Tile.**—Where wooden floorbeams are used, they naturally rest on the wall at each end, and the wall should be built so as to provide a suitable bearing for them. As a rule, the wall diminishes in thickness at the level of the floorbeams so that a shelf is formed by the projection of the lower wall beyond the upper wall, and upon this the floorbeams generally rest, as shown in Fig. 29. Where the difference in the thickness of these walls is 4 inches, a sufficient bearing is afforded for the average wooden joist, and flat tiles as in (*a*) and (*b*) or a row of bricks as in (*c*) is laid on top of the 4-inch projection. Upon these tiles or bricks the ends of the joists are placed.

Where there is a difference of only 2 inches in the thickness of the walls or where the walls of both stories are carried up at the same thickness, it becomes necessary to extend the ends of the joists into the upper-story walls so as to obtain at least a 4-inch bearing. This condition calls for a special arrangement of the tiles at the level of the joists, as illustrated in Fig. 30.

In this figure the joists are shown bearing upon a 1-inch flat slab *a* that is carried entirely through the wall. This affords a

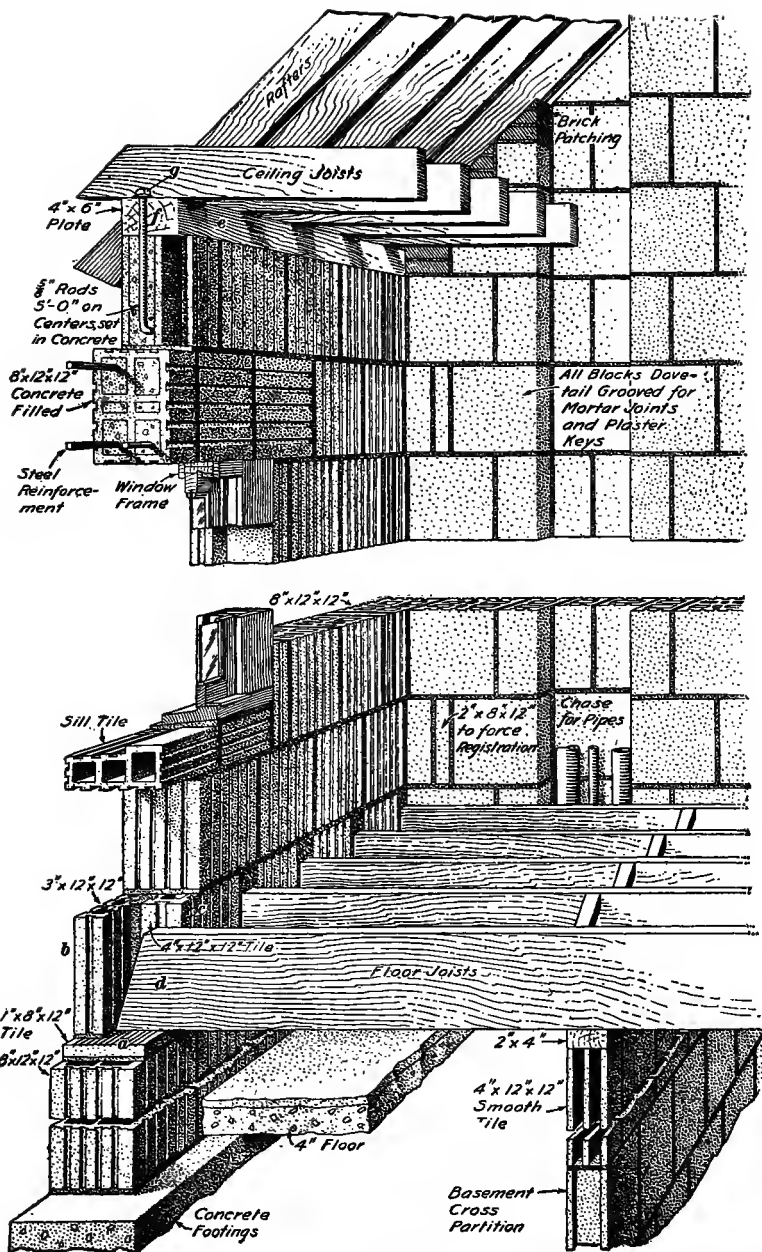

FIG. 30

flat bearing for the ends of the joists. Between the ends of the joists and the outside of the wall a row of thinner wall tiles *b* is placed and a second row of tiles *c* is placed between the beams. These two rows together form a base upon which the wall above rests.

**68.** A method that is sometimes used for supporting<sup>\*</sup> wooden floor joists is shown in Fig. 31 in which the joists are suspended by means of steel joist hangers *a*, which are in turn supported upon flat 1-inch slabs *b*. An advantage in this method is that the trouble of fitting the tile around the ends of the joists is avoided.

**69. Anchoring Wooden Floor Joists.**—The ends of joists when projecting into a tile wall should be cut with a *fire cut*, as shown at *d*, Fig. 30.

This cut is so called because it permits the beam to fall out without injuring the wall if the timber should be burned off.

Every fourth joist should be anchored to the wall by means of a wrought-iron rod, strap, or *dog*, driven into the top of the joists and built into the masonry. The purpose of these anchors is to tie the floors to the walls, and thus give greater stability to the building. Walls parallel to floor joists should be anchored by metal straps nailed to three or four joists and turned up into the wall.

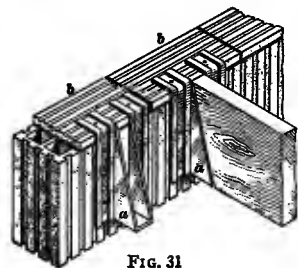

FIG. 31

The purpose of these anchors is to tie the floors to the walls, and thus give greater stability to the building. Walls parallel to floor joists should be anchored by metal straps nailed to three or four joists and turned up into the wall.

**70. Supporting Fireproof Floors on Regular Tile.** The several forms of fireproof flooring used in connection with hollow-tile construction will be described and illustrated later, but the provision that must be made in the walls to receive the floors will be described at this point.

The floor systems mostly used in connection with hollow-tile construction are the flat concrete slab, the combination floor of hollow tile and reinforced concrete, the Johnson system, and the New York wire-truss system; and they all require that the

bearing walls supporting them have a flat tile placed over the ends of the cells to receive the floors. These floors extend to within 4 inches of the outside of the tile wall and a 3-inch facing tile is placed as shown at *a* in Fig. 32. At *b* is shown the flat bearing tile on which rests the floor system *c*, the weight of which is thus transferred to the bearing wall *d*. The upper-story wall *e* is started directly on the floor construction, as shown in the figure. In Fig. 33 the floor construction is shown resting on the lintel over an opening.

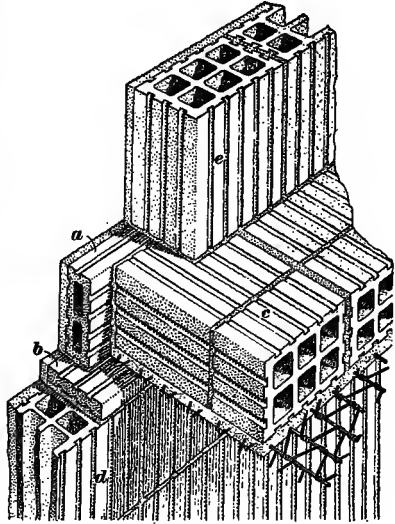

FIG. 32

### 71. Concentrated Supports.—In the floor

systems that have been mentioned the load is distributed over the bearing walls quite uniformly and does not necessarily

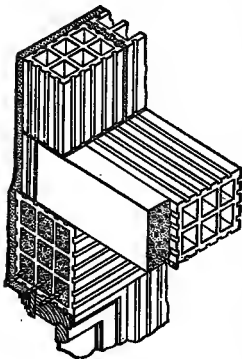

FIG. 33

bring any concentrated load on any particular point in the wall. Where steel girders are used, concentrated loads occur at the bearings of these girders, and the wall must be especially strengthened at these points. This is done by filling the cells of the tile with concrete for two or three courses below the bearing of the beam, or even down to the footings, to form a solid masonry pier under the load. Where the cells of the tile are in a horizontal position, a brick pier is sometimes built extending down

for several tile courses and spreading out toward its lower part. This distributes the load over a large area of wall below.

**72. Supporting Non-Fireproof Roofs on Regular Tile.**—Flat non-fireproof roofs are supported in the same manner as non-fireproof floors; that is, the rafters, being flat, are supported in the same manner as floor joists. Where the roof pitches, the lower ends of the rafters are supported, as shown in Fig. 30, on a plate *e* which is anchored to the wall so that it will not be pushed off by the thrust of the rafters,

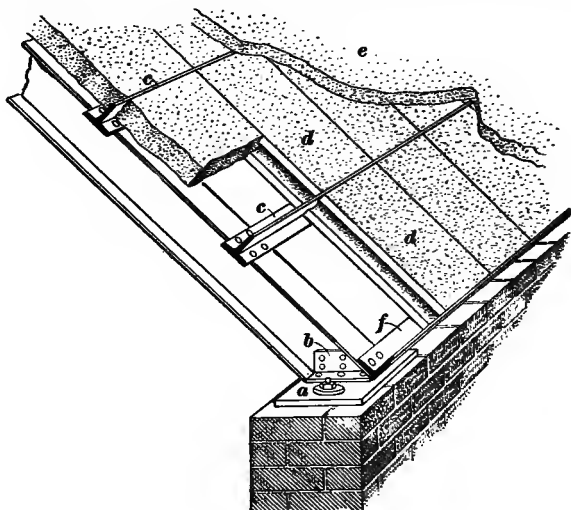

FIG. 34

although as an additional safeguard the lower ends of the rafters are generally tied together by means of the attic-floor construction. The anchors *f* consist of bolts which extend down into the wall, either through the blocks or between them, and also extend above the plate so that nuts and washers *g* can be used to hold the plate in position.

**73. Supporting Fireproof Roofs on Regular Tile.** As a matter of fact, it is unusual to build fireproof roofs on dwellings. Generally the houses are built fireproof up to and including the attic floor, a timber construction is used for the roof, and this is covered with a fireproof covering or roofing, such as slate, tile, or asbestos shingles, so that the roof itself will not catch fire from without.



As in the case of the non-fireproof construction, flat roofs of fireproof construction are similar to the floors in their design.

For pitched roofs of fireproof construction the same principles are used as in non-fireproof construction. As shown in Fig. 34, a metal plate *a* is anchored to the wall by bolts built into the wall and extending up through the plate so that a nut may be screwed on the top of the bolt to hold the plate in position. The rafters, which are generally I beams, are anchored to the plate as shown at *b*, and T irons *c* and an angle iron *f* are secured to the rafters at such a distance apart as to take the

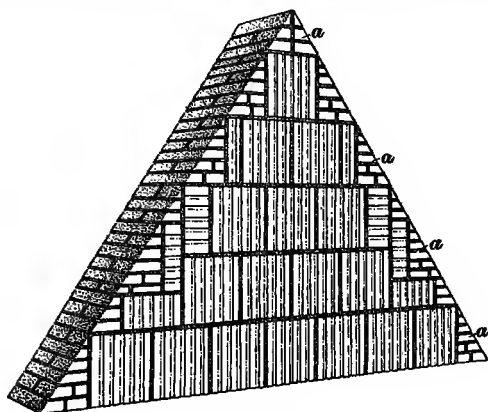

FIG. 35

tile *d* called book tile. A layer of cinder concrete *e* is then placed over the book tile and the roofing is nailed to it.

**74.** Pitched roofs may be made of the combination construction used for floors, which is described later on. This construction is exactly the same as a floor set on a slope. It is an expensive construction and is used only on elaborate work.

**75. Finishing Gables.**—In building gable walls of hollow tile it will be found wasteful to cut the blocks to a triangular shape to fill in the spaces *a*, Fig. 35. These triangles are therefore generally filled with brickwork as shown in the figure.

## WALLS OF H TILE

**76.** The shapes of H tile have already been shown. The sizes are 12 in.  $\times$  8 $\frac{1}{4}$  in. horizontally, and 5 $\frac{1}{8}$  in., 7 $\frac{3}{8}$  in., and 10 $\frac{1}{4}$  in. vertically. The vertical heights, plus the thickness of one mortar joint, correspond to two, three, and four courses of common brick with the necessary mortar joints. A single block makes a wall 8 $\frac{1}{4}$  inches thick. When a 13-inch wall is required, the thickness is made of one 8 $\frac{1}{4}$ -inch tile and a half tile. These half tiles are made and carried in stock but may also be obtained by simply splitting the whole tile. The half tiles in such a wall are placed on the outside and the inside of the wall in alternate

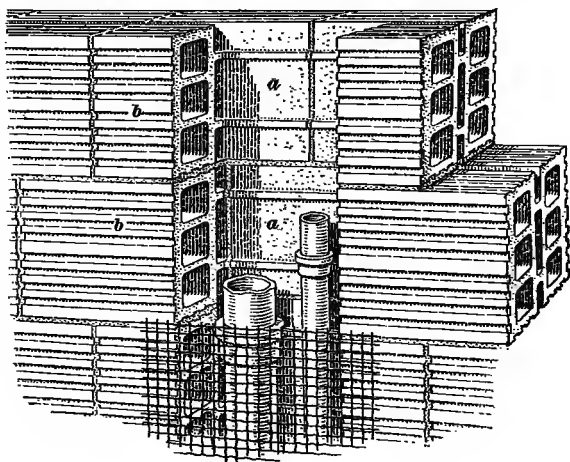

FIG. 36

courses as shown in (b) in Fig. 17. It will be noticed in this figure that the horizontal bed of mortar is broken into 3 parts so that it is not continuous through the wall.

**77. Supporting Floors on H Tile.**—Floor joists of wood are supported directly upon the upper surface of the blocks. The joists extend into the wall so as to bear upon two lines of vertical webs. The spaces between the ends of the joists are filled with 4 $\frac{1}{8}$ -inch tiles, which are the standard blocks split in two. Fireproof floors are supported in the

same manner, but such floors must be carried to within about 4 inches of the outer face of the wall so as to have as large a bearing as possible.

**78. Supporting Plates.**—The plates for supporting the lower ends of roof rafters on H-tile walls are secured in the same manner as on brick walls or walls of regular tile. Bolts are built into the wall so as to extend down about 16 or 18 inches and also to project through the top of the plate and receive a nut.

**79. Finishing Gable Walls.**—The triangular spaces in gable walls are finished in the same manner as for regular tile, as shown in Fig. 35 at *a*.

**80. Chases.**—Chases may be formed by the use of blocks of half thickness, as at *a*, Fig. 36, and bonding them into the full-thickness blocks *b*.

---

#### WALLS OF T-SHAPED TILE

**81. T-shaped tiles** are laid up in the wall as shown in Figs. 12, 13, 14, 15, and 16. In the 16-inch wall in Fig. 12 (*c*), a special tile *f* is required to complete the bond properly. Walls of other customary thicknesses, however, can be built with the regular T-shaped tile. A solid block of special shape is required to start the wall at the bottom, as shown at *e*, Fig. 12 (*a*), (*b*), and (*c*).

Jamb blocks are placed on end at each side of the opening, and must be securely anchored to the wall as shown in Fig. 13. Corner blocks of two different heights, as shown in Fig. 13 at *d* and *e*, are required to finish the corners properly. Chases are built as shown in Fig. 15.

Floors and roof plates are supported in the same general way as is done in H-tile walls.

---

#### VENEERED WALLS

**82.** By veneering the outer surface of a hollow-tile wall with brick, the advantages in appearance due to the brick facing, and of the air spaces and lightness due to the hollow-tile construction, are both secured.

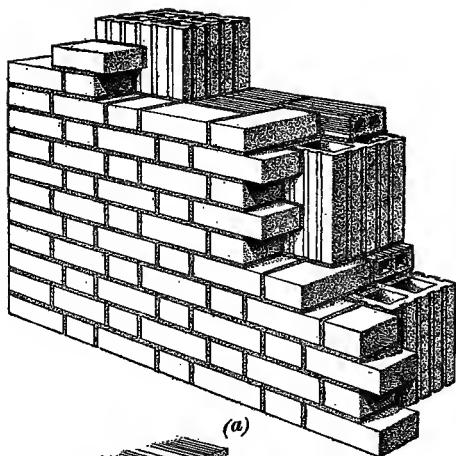

(a)

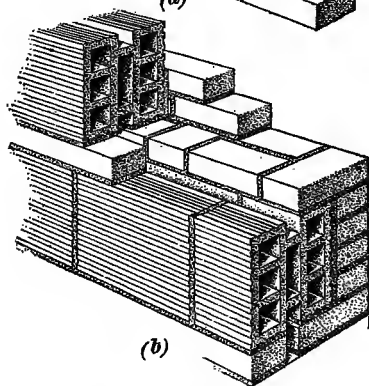

(b)

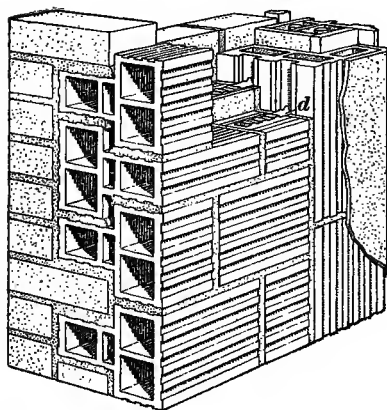

(c)

FIG. 37

The principal problem in constructing a brick-veneered wall is the bonding of the brick face securely to the tile backing. The various types of tile mentioned are designed so that this bonding may be readily accomplished. In Fig. 37 are shown the methods of tying or bonding the brickwork to the tile work

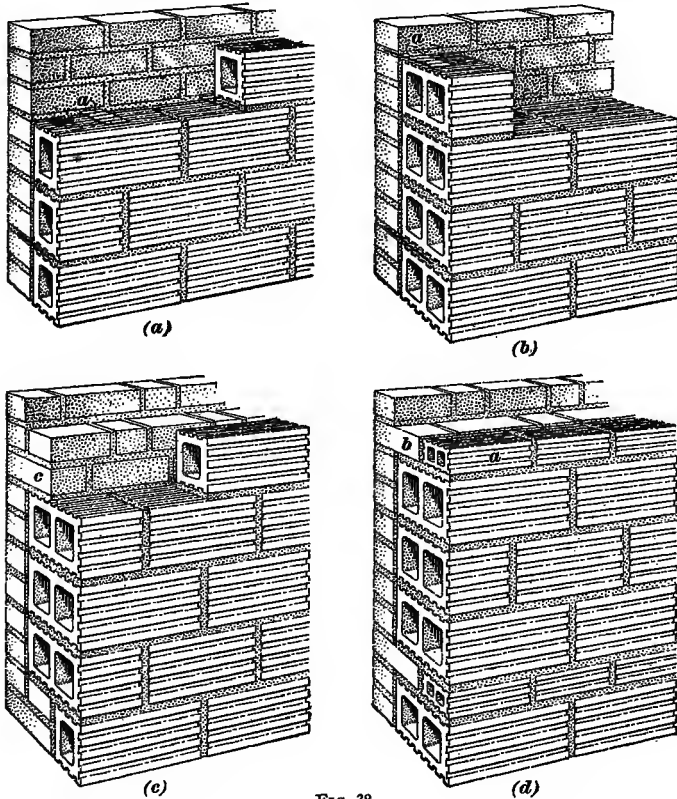

FIG. 38

of the three types already described. In (a) is shown the method used with the regular tile; in (b) and (c), with **H** tile and **T** tile. When it is desired to show no headers in the brick facing it is necessary to tie it to the tile with metal ties, in the manner shown at *a* in Fig. 38 (a) and (b). When brick-veneered walls are used, it is a frequent custom to use solid

stone sills and lintels for the window openings as well as stone string-courses, as is done in a brick building with solid walls.

**83. Backup Tile.**—A special type of hollow tile, called *backup* tile, is manufactured for use in backing up brick veneering. By using this tile a very light and economical wall can be built. The *backup* tiles are made with one face smooth for use in places where it is not desired to plaster the interior face of the wall. These tile are sometimes called "*Jumbo*" brick.

Where the brickwork shows only stretchers on the face, the bond to the backing is made by using metal wall ties as shown



FIG. 39

at *a* in (*a*) and (*b*), Fig. 38. Where, however, heading courses of brick are used, headers can extend into the wall as shown in (*c*) and (*d*). By using hollow-tile brick, as shown at *a* in (*d*), only one course of face brick is needed in forming the bond instead of two courses as shown in (*c*).

Fig. 39 illustrates a method of laying up a wall consisting of a brick-veneered face, backup-tile backing, and metal ties.

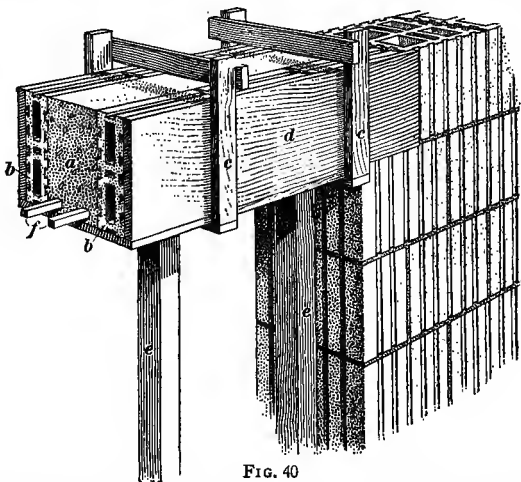

FIG. 40

Two of these ties are shown projecting from the back of the face-brick veneering between the hands of the two men.

#### OPENINGS IN WALLS

**84. Openings.**—Openings in walls are generally for doors and windows. The blocks that are used around such openings, such as lintels, jambs, and sills, have been illustrated.

The lintels are the only blocks that vary with the width of the opening. Lintels have been shown for spans of not over 5 feet. For lintels of a greater span than 5 feet, reinforced concrete or steel must be depended upon.

In Fig. 40 is shown a lintel which consists of a reinforced-concrete beam *a* faced with hollow tile *b*. The concrete beam is designed to carry all the load coming from the wall above the opening as well as from floor-beams that may rest on this wall.

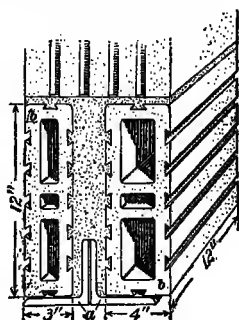

FIG. 41

The lintel is faced with thin blocks of hollow tile, which afford a better surface for stucco and plaster than the concrete surface would. These tiles adhere strongly to the concrete lintel, as the concrete flows into the dovetail grooves when the lintel is cast.

A lintel of this type is generally cast in position. The lintel shown in this figure is made in a wooden form, as shown at *d*. This form must be strongly supported by the struts *e*, and its sides must be braced as shown at *c*, so that they will not spread apart when the concrete is cast in place. The tiles *b* are first placed in position and the rods *f* are set so that they will be about 1 inch above the bottom of the lintel. The concrete is then poured into the space *a* and allowed to set for a few days until it has attained considerable strength, when the forms may be removed.

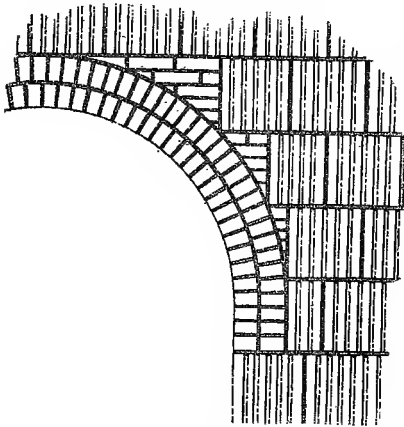

FIG. 42

A lintel that requires no forms and that will be ready to bear the load within a day or so is shown in Fig. 41. This lintel is virtually a steel lintel formed of two angles *a*, upon which terra-cotta blocks *b* are set, and concrete or cement mortar is filled in between them. The strength of this lintel is that of the two steel angles.

**85. Arched Openings.**—Arched openings in hollow-tile walls are made by using either plain bricks in the form of row-lock arches as shown in Fig. 42, or by using hollow-tile blocks as voussoirs, or arch blocks, as shown in Figs. 43 and 44.

In the arch shown in Fig. 42 the rectangular tile blocks are not cut to fit the triangular spaces, as brickwork is used to fill up these spaces, as shown.



## COLUMNS AND PIERS

**86. Columns.**—Many designs for hollow-tile houses require round columns in such places as the front entrance or

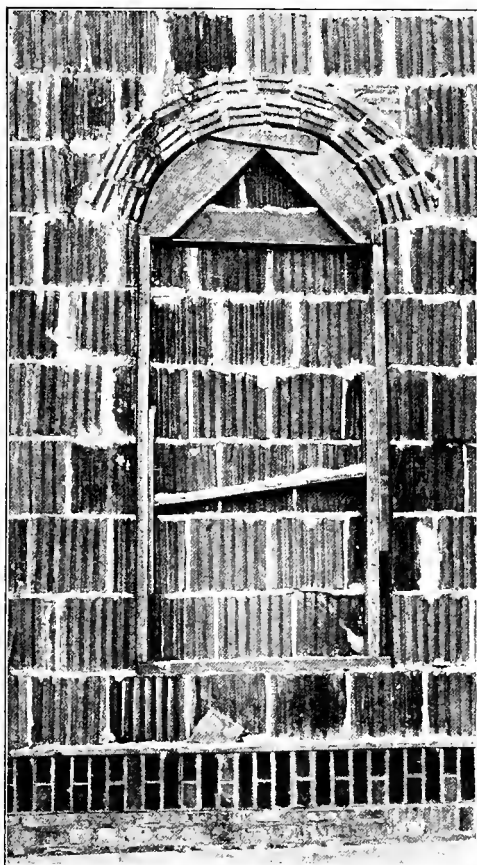

FIG. 43

on porches. Manufacturers make a *radius tile*, or tile molded with a curved surface, such as shown at *a* in Fig. 45, which can be laid up to form cylindrical columns of different diam-

eters. When these columns are expected to support an extra-heavy weight the interior of the cylinder is filled in solidly with concrete *b*, which is sometimes reinforced with rods or bars *c*.

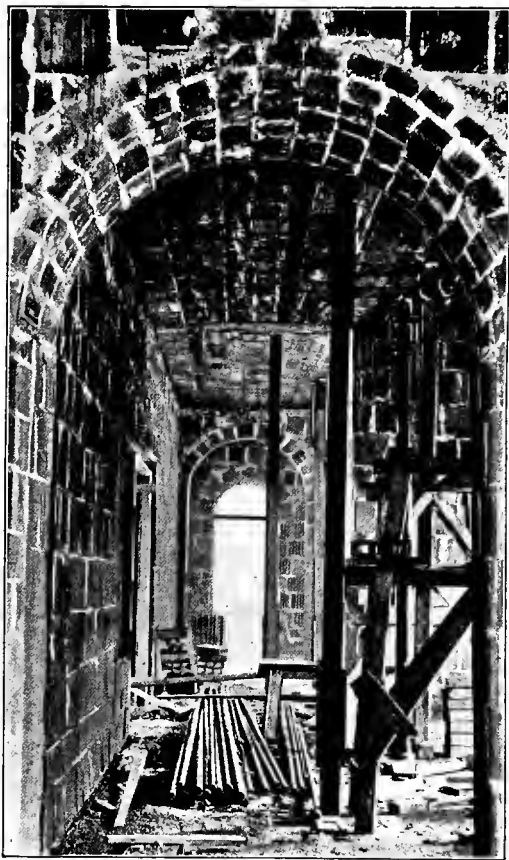

FIG. 44

Columns of this description are practically reinforced-concrete columns and will support loads in proportion to the diameters of the concrete cores. The enclosing tile is generally scored on the outside so as to hold a finishing coat of stucco.

**87. Piers.**—Piers, as shown in Fig. 46, can be built of stock-size blocks, which must be set up so as to break joints in

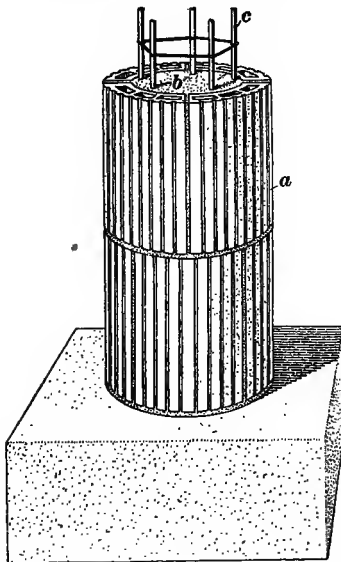

FIG. 45

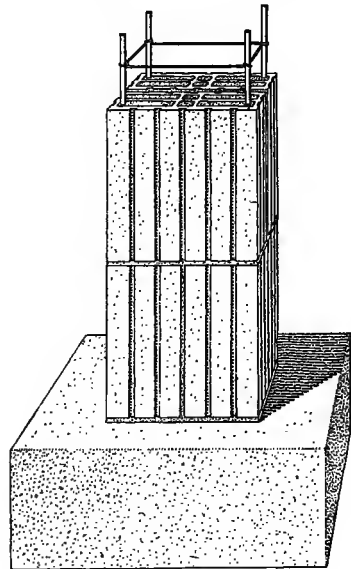

FIG. 46

alternate courses. These piers should be filled with concrete when supporting heavy loads. Reinforcing rods may be added as shown where greater strength is required.

#### ATTACHING FURRING, TRIM, ETC. TO WALLS

**88. Use of Wooden Laths.**—Many architects prefer to fur the interiors of all external walls of hollow-tile construction, as this provides space between the tiles and the plaster for gas and water pipes and electric conduits. It also affords a means of preventing cold striking through the walls to the plaster and causing moisture to condense on the face of the plaster. When the use of furring is contemplated, wooden laths are often built into the horizontal joints between the tiles at proper distances apart to afford nailing for the furring strips. This is illustrated in Fig. 47 at *a*.

**89. Metal Wall Plugs.**—Another good method of providing nailing for wooden furring is to use metal wall plugs, shown at *b* in Fig. 47. These plugs are small bent corrugated plates of metal that are set in the mortar joints while the wall is being built, and receive and hold nails driven into them through the furring strips as shown in the illustration.

**90. Self-Clinching Nails.**—Self-clinching nails may also be used for fastening wood to tile. These nails, shown in Fig. 47 at *c*, are driven through the furring strips and also

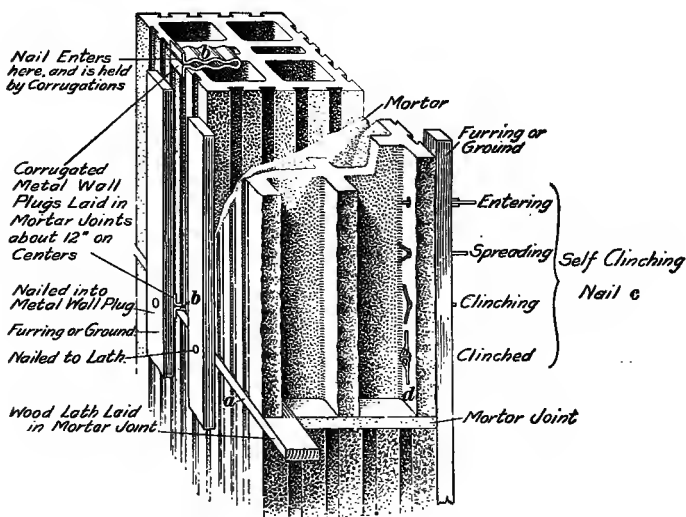

FIG. 47

through the shell of the tile, in which holes have previously been punched. The last blows of the hammer cause the nails to spread and clinch on the back of the shell as shown at *d*. An enlarged view of a self-clinching nail is shown in Fig. 48. In (*a*) the nail is shown closed and ready to drive, in (*b*) the nail is shown driven through the furring and tile and clinched.

**91. Toggle-bolts** are shown in Fig. 49. These bolts have heads *a* that are hinged to the bolts. A hole is made in the tile of sufficient size to allow the head to enter as shown

in (b). When the head has passed through the hole the head is turned on the hinge so that it stands at right angles to the hole. The threaded shank of the bolt extends through a hole bored through the furring and is fitted with a nut which is screwed up and holds the furring firmly in place. In (c) is a view of a toggle-bolt in position.

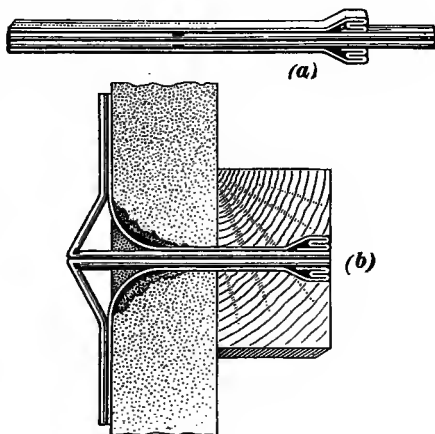

FIG. 48

**92. Ankyra Ankor Bolts.**—A useful form of expansion bolt for use in securing furring, grounds, etc., to hollow-tile walls is known as the Ankyra Ankor bolt and is illustrated in Fig. 50. In (a) is shown the bolt, which consists

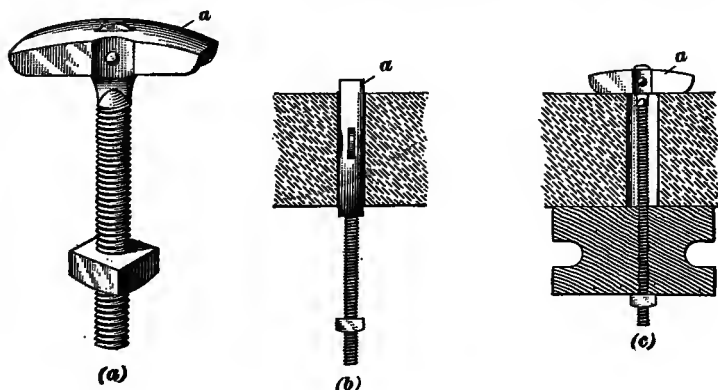

FIG. 49

of a divided shell *a*, a collar *b* with a projecting portion or lug *c*, and a collar *d* which is threaded to receive an ordinary wood screw such as *e*. In (b) the bolt is shown drawn up so that the shell *a* expands in three directions. In (c) the bolt is

shown under various conditions. At *a* is a hole that is punched through the terra-cotta tile *b* into which the shell of the bolt *c*

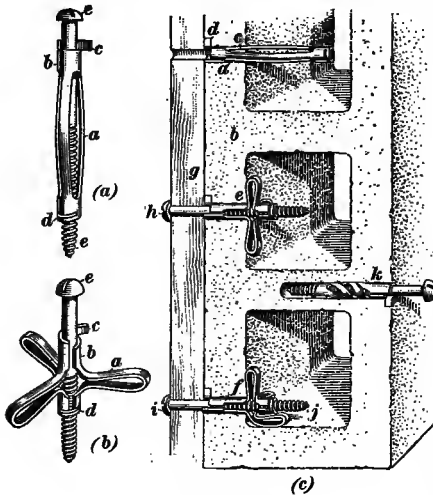

FIG. 50

has been driven. A slight tap of the hammer will drive the lug *d* into the tile and the lug will keep the shell of the bolt from revolving or slipping into the hole. The shell is then pulled together as shown at *e* and *f* by means of a device inserted into it. This establishes the shell firmly in place and it is ready to receive the screw that is to hold the furring in place as shown at *h* and *i*. The tighter the screw is turned the firmer the hold this bolt will take. The position that a bolt will take in a corner is shown at *j* and the method of holding in solid terra cotta is illustrated at *k*.

**93. Grounds** to which trim, base, wainscoting, picture moldings; etc. can be nailed can be secured to the tile walls in the same way as furring strips.

### PARTITIONS OF HOLLOW TILE

**94. Partitions.**—Interior partitions of hollow tile are usually made thinner than outside walls, because they do not have to resist the weather and frequently they carry only light loads. Interior partitions in ordinary houses are built of 3-inch, 4-inch, or 6-inch blocks. In a fireproof house, where the weight of fireproof floors must be taken into account, the main bearing partitions are sometimes made of 8-inch blocks.

It is necessary that tile partitions be rigidly supported. They must therefore rest upon solid walls or partitions beneath or upon steel beams. When fireproof floors are used, partitions in the upper stories may be set on these floors slightly to one side of the partitions below, or, in other words, need not be set directly above them.

The blocks used for partitions are those used in fireproofing and are described in the Section entitled *Fireproofing of Buildings*.

---

### FLOOR SYSTEMS

**95.** The floor systems used in connection with hollow-tile walls are not peculiar to them. In fact any of the flooring systems used in other buildings can be used equally well in buildings having hollow-tile walls. As these floor systems are described elsewhere, it would be repetition to describe them extensively here, consequently a merely superficial description will be given.

**96. Non-fireproof floors,** such as are used in ordinary frame structures, are most frequently used in tile buildings, but are not to be recommended, on account of their inflammable nature.

**97. Hollow-Tile Fireproof Floors.**—While any type of fireproof floor can be used in connection with hollow-tile walls, the most natural fireproof floor to use is one that is composed of the same material as the wall; that is, hollow terra-cotta tile.

Two systems that make use of plain hollow-tile blocks as an essential part of their structure are the *combination floor system* and the *Johnson system*. These types of floors are the ones most used in dwellings. In larger buildings the flat-arch floor systems, the segmental-arch system, and the wire-truss system are employed. As these last-mentioned systems are described in the Section entitled *Fireproofing of Buildings*, they will not be described here.

**98. The Combination Floor.**—What is generally known as the *combination floor* is frequently employed for

ordinary spans. This floor consists of what may be described as reinforced-concrete beams with hollow tile held between them.

In building such a floor, planks are first erected as a form or temporary support for the entire floor. Upon this form or platform, sometimes called *centering*, the tiles are laid in rows about 16 inches on centers with the cells lying in the direction of the rows. After the tiles are all laid, reinforcing rods are placed at the bottoms of the spaces between the rows and

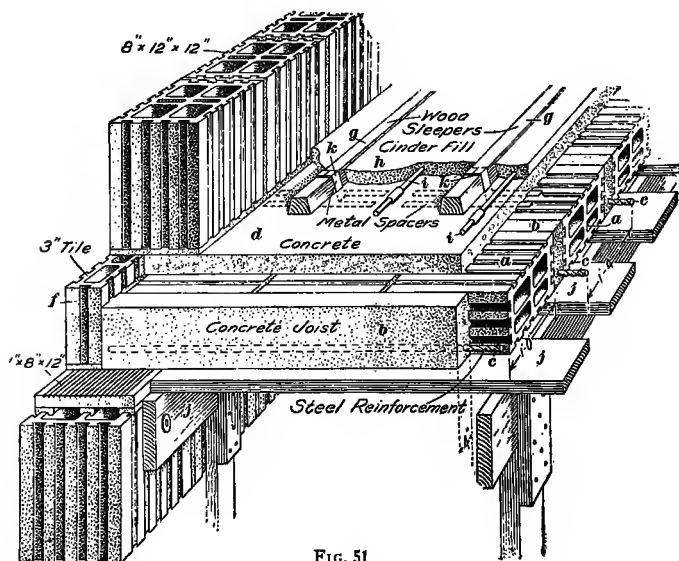

FIG. 51

concrete is poured into the spaces and over the top of the entire construction to a thickness of about 2 inches, as shown in Fig. 51. This figure shows the hollow tile of the floor at *a*, the reinforced beams at *b*, the reinforcing rods at *c*, and the 2-inch layer of concrete over the top of the tile at *d*. The rods *c* are kept up above the centering about  $\frac{3}{4}$  inch; so as to be entirely embedded in concrete and thus protected from rusting and fire. The entire construction rests upon 1-inch flat tile slabs set on the wall, and is faced on the outside of the wall



with 3-inch facing tile *f*. The upper wall rests directly upon this floor construction.

On top of the floor construction, wooden cleats, or sleepers, *g* are laid about 12 inches on centers to afford nailing for the wooden floors. These sleepers are made from 2"×4" stuff and are beveled on both sides. They are secured in place by the use of sheet-metal spacers *k*, that are held down by the weight of the concrete that is placed upon them, and are nailed to the sleepers. It is customary to fill in between these sleepers with cinder concrete *h*. After this fill has become thoroughly

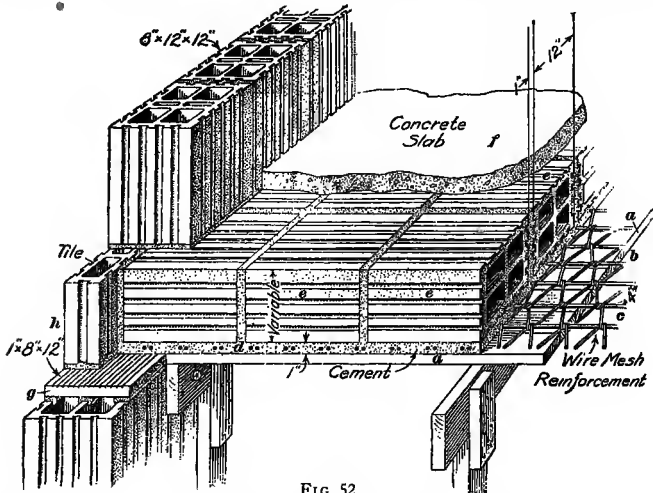

FIG. 52

set, a layer of heavy building paper is placed on top and the finished floor is nailed to the sleepers. Before the cinder concrete is placed between the sleepers, gas and water pipes and electric-wire conduits, as at *i*, are put in place.

The floor is supported on the wooden forms *j* until it has thoroughly set, when the forms may be removed.

**99. The Johnson Floor.**—Another type of fireproof floor that is frequently used in dwellings and other small buildings is known as the Johnson system, and is formed largely of hollow-tile blocks. The Johnson-system floor is sometimes more economical for wide spans than the combination floor.

In erecting the Johnson floor, a centering *a*, Fig. 52, consisting of a floor made of matched boarding is built, and on this platform a network of steel reinforcement *b* is laid, usually consisting of a heavy metal fabric reinforced by steel reinforcing bars *c*, placed at intervals of 5 or 6 inches. This metal is then embedded in a layer of cement mortar about 1 inch thick. On top of this layer, tile blocks *e* are laid in rows as in combination floors, but about 1 inch apart. The size of the tile varies according to the span and the load.

Concrete is poured into the spaces between the rows of blocks and, where the loads are ordinary, filling these spaces is sufficient. When the loads are heavy a concrete slab *f*,

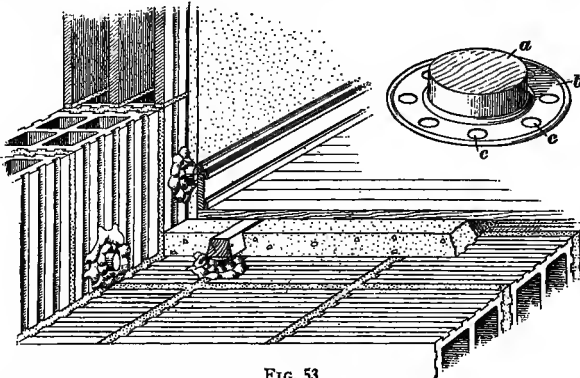

FIG. 53

about 2 inches in thickness, is poured over the tops of the blocks at the same time. As in the case of the combination floor, this floor rests on a flat slab *g* on the wall and is faced on the outside of the wall with a 3-inch facing tile *h*. The details of placing sleepers, pipes, and the finished floors are the same as in the combination floor.

**100. Securing Sleepers, or Cleats, to the Floor Construction.**—To secure wooden floor sleepers, or cleats, to which the floor is nailed, there are several appliances. One of these consists of small galvanized-iron hooks each of which has a flat end that is embedded in the cinder concrete and a sharp end that is driven into the cleat when the cleat is in its

proper position. These hooks are spaced about 12 inches on centers and hold the cleats firmly in position. Other methods consist of metal strips that are embedded in the cinder concrete and have projecting ends that can be bent over the cleats and nailed to them as shown at *k* in Fig. 51.

A very efficient and ingenious method of attaching furring, sleepers, and grounds to hollow tile is by the use of what are known as *spot grounds*, illustrated in Fig. 53. These grounds consist of a disk of wood *a*, firmly attached to a circular flange of sheet metal *b*, which is perforated with holes *c*. The grounds are secured to the terra-cotta surface by the use of plaster of Paris or Portland cement. Before the plaster has set, the grounds are brought to the correct level so that the furring or sleepers when nailed to the grounds will be straight and level. When the plaster or cement has hardened they afford firm spots into which nails may be driven.

---

## ROOF CONSTRUCTION

**101.** As has been stated, fireproof roofs are not generally placed on hollow-tile buildings. When, however, they are used they are similar in construction to floors or fireproof roof constructions that are described elsewhere.

## STUCCO FINISH

**102. Need of Finish on Tile.**—The natural appearance of a tile wall is not very attractive or artistic unless the tile is made with special surfaces, as in the case of Textile blocks. Tile walls are, therefore, generally covered with a stucco, or plaster, which is applied so as to produce artistic effects.

---

### COMPOSITION OF STUCCO

**103. Stucco.**—What is known as *stucco* is in reality a cement plaster formed of Portland cement, sand, lime, and water, and applied in the same manner as ordinary wall plaster.

**104. Ingredients of Stucco.**—The Portland cement may be of any of the standard brands such as the Atlas, Alpha, Lehigh, Universal, or Vulcanite. These cements are generally of a gray or mouse color and may be used in the first coats of stucco and in the finishing coat when this gray tint is satisfactory.

Portland cement is also made of a pure white color. Such cement is used when it is desired to produce a pure white color in the finishing coat; also when light tints of various colors are required. The white cement merely lightens the tint of any coloring material that may be added to the stucco without destroying the quality of the color. When delicate tints or tones of pink, yellow, or brown are sought, white Portland cement should be used.

**105.** The **sand** should be clean, free from loam, salt, and other impurities. It should consist of coarse and fine particles mixed together rather than of uniform-sized grains. Ordinary sand possesses a yellowish or reddish color which affects the color of the stucco. When used with a gray Portland cement it results in a gray or mouse-colored stucco. The colors of

the gray cement and the sand greatly modify the effect of mortar colors that are used in coloring stucco and make it impossible to obtain light tints such as buffs, pinks, yellows, etc.

In order to obtain delicate light colors in the stucco, white cement should be used and also *white sand*. Instead of white sand, pulverized marble is sometimes used. This is called *marble dust*. By the use of white cement and white sand or marble dust, light pure tints can be obtained by using small quantities of mortar colors.

With the use of white cement and sand as a base, delicate and desirable tints can be produced by adding **crushed stone** of various colors to the stucco. The stones used for this purpose are marbles, granites, and other crystalline rocks, as well as pebbles that possess high colors. These colored particles of stone should show in the face of the stucco in order to produce a color effect in the wall.

**106.** The best form of **lime** to use is hydrated lime, which is a carefully and scientifically slaked lime and is in the form of a fine white powder. It can be mixed dry with cement and sand, and when all these ingredients are thoroughly mixed the water can be added.

Lump lime is sometimes used instead of hydrated lime, but must be carefully slaked, strained, and allowed to stand for a week or ten days before using.

**107.** The **water** used in mixing the stucco should be free from alkalies, acids, and vegetable matter, as these materials may interfere with the setting of the cement.

**108. Mortar Colors.**—The coloring materials used in tinting stucco are known as *mortar colors*, and are the same as are generally used in coloring mortar used in brick and stone masonry. The best of these mortar colors are sold in pulp form so that they will mix readily with the mortar or stucco. When mixing different batches of colored mortar for the same job, great care should be taken that the same fixed amount of colors is used for a given amount of mortar or stucco. If this is not done the different batches of mortar will show different

tints on the surface of the wall. Only the best and most permanent colors should be used or else the colors will fade or disappear in time.

#### APPLICATION OF STUCCO

**109. The First, or Scratch, Coat.**—When the hollow-tile walls of the building have been finished and the roof is in place, the building is ready to be *stuccoed*. As with any plastering, the weather conditions should be suitable; that is, neither too hot nor too cold.

Scaffolds should be erected entirely around the building, after which the mechanics can put on the first coat of stucco,



FIG. 54

which should be pushed firmly against the tile so that it will flow into the grooves and make a secure bond. Deep-grooved tile is best for use in work that is to be stuccoed, as the grooves provide a good mechanical bond between the stucco and the tile. When glazed tile is used, the dovetail scorings on the tile are the only means of holding the plaster to the tile, as the

glazed surface affords no bond whatever. In semiporous tile the slight absorptive power of the surface of the tile affords a grip for the stucco.

When the first coat has hardened slightly it should be *scratched*. This is usually done with a piece of board that has its edge notched, as shown in Fig. 54. This scratching gives a rough surface to which the second coat will adhere. The first coat should thoroughly fill all the grooves in the face of the tile and cover the tile with a thickness of about  $\frac{1}{4}$  inch.

**110. The Second Coat.**—The second coat is applied when the first coat has set but before it has dried. It is when putting on this coat that the surface of the plastering is made true and smooth. This is done by using long straightedges at the corners of the building and around the openings and working the stucco to an even surface between them, all hollow spaces being filled in and projecting ones cut down. All this straightening is done while putting on this second coat.

**111. The Third Coat.**—After the second coat has set, but before it has dried, the third, or *finishing*, coat is put on. This third coat is the one that is visible to the eye and gives character to the appearance of the building. This character or effect is caused by the color and the texture of the finished surface. By the use of various materials and processes a large variety both of color and texture can be obtained.

---

## FINISHES

**112. Color.**—As has just been stated, the appearance of the stucco depends upon the manner in which it is finished with regard to color and texture. The matter of obtaining various colors has been considered under the head of the Composition of Stucco. When mortar stains are used, the mass of the stucco is colored uniformly. When, however, the color depends upon the color of the sand or broken stone which is mixed with the stucco, it is generally found necessary to clean away a film of cement which naturally covers these colored aggregates,

so that they may show in the surface of the wall. This is done by scrubbing the wall with brushes and clean water when the stucco is fresh, or by using dilute muriatic acid and brushes if the stucco is several days old. This treatment removes the film of cement and exposes the aggregates in their natural color and brilliancy and the color effect of the wall is determined by the color of these aggregates.

**113. Texture.**—The texture, or degree of roughness, of the surface of the stucco, has a great effect upon its appearance. A perfectly smooth and even surface can be obtained by using fine materials and working them to a perfectly uniform and smooth surface. It is found, however, that such a treatment is likely to prove flat and uninteresting in its effect. A rough surface is generally more interesting, due to the play of light and shade upon it caused by the projecting particles of mortar.

This texture is obtained by using coarse sand, grit, and pebbles in mixing the stucco, as well as by the method of applying the stucco. The wall surface may be finished smooth by using a steel trowel or it may be made rough by using a cork or wooden float or by placing a piece of carpet over the float. The surface may be roughened by stippling it before it has hardened and a rough but uniform effect obtained. The stucco is often thrown against the second coat and a rough surface produced. The stucco may be mixed with grit or small pebbles and thrown against the second coat and a very rough surface obtained.

Thus it will be seen that there are numerous devices used to obtain what are considered as desirable effects in the finishing coat.

**114. Sand Finish.**—A *sand-finished* or *sand-floated* surface is obtained by using coarse sand in the final coat. This coat is put on in the usual manner. When it has hardened slightly it is rubbed with a wooden float, using a circular motion which brings the sand to the surface of the stucco and gives a pleasing roughness or texture to the wall.



**115. Rough Cast.**—When the finishing coat is brought to an even surface, a mixture of cement and sand is thrown against the face of the wall by means of a small wooden paddle or a whisk broom so as to roughen it more or less uniformly.

**116. Pebble Dash.**—The finishing coat is brought to an even surface and pebbles varying in size from  $\frac{1}{4}$  inch to  $\frac{1}{2}$  inch are thrown against the soft stucco surface so as to be distributed as evenly as possible. The pebbles should be wet and should be thrown against the surface with sufficient force to make them adhere, or they may be pressed into the stucco with a clean board.

**117. Water Necessary.**—The stucco should be kept moist at all times until it has been completed. It should be frequently sprayed or should be covered with wet burlap so that it will not dry out too soon.

---

## EXAMPLES OF BUILDINGS OF HOLLOW TILE

**118. Dwellings.**—Hollow tile is used for dwellings of all kinds, such as bungalows, cottages, and mansions. Illustrations of a dwelling built of Denison load-bearing, or **H**-tile, blocks are given in Figs. 55 and 56. Fig. 55 shows the building ready for plastering and Fig. 56 shows the plaster or stucco coat in place. The stucco surface has been finished in rough cast and presents a coarse and vigorous texture. Figs. 57 and 58 are two dwellings built of **H** tile and ready to receive the stucco coating. These illustrations show quite clearly the methods used in building with hollow-tile blocks.

**119. Apartment Houses.**—Apartment houses are frequently built with walls of hollow tile, such tile being used for outside and inside walls up to the roof; and sometimes fire-proof floors are used.

Examples of apartment houses built of tile are shown in Figs. 59 to 64, inclusive. Fig. 59 shows an apartment building built of interlocking tile, or **T**-shaped tile. This illustration



*Courtesy of the Demson Fire-Proofing Co., Mason City, Iowa*

FIG. 55

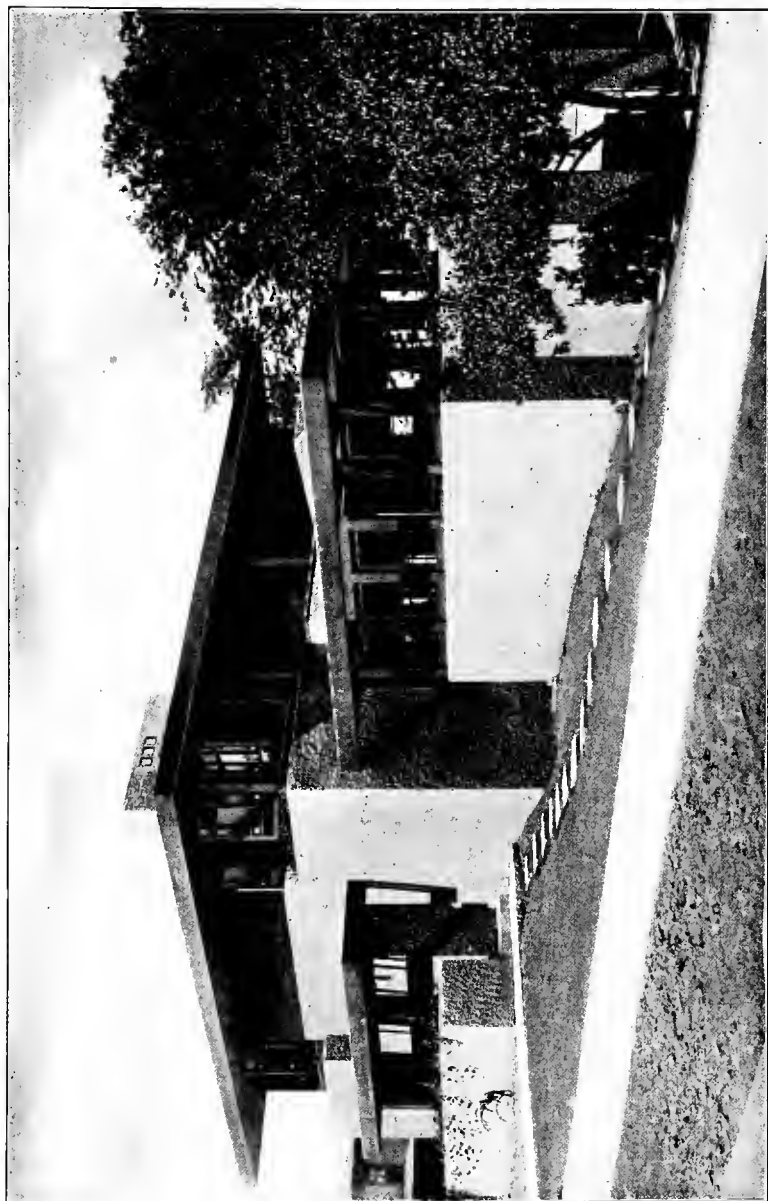

*Courtesy of the Denison Fire-Proofing Co., Mason City, Iowa*

FIG. 56

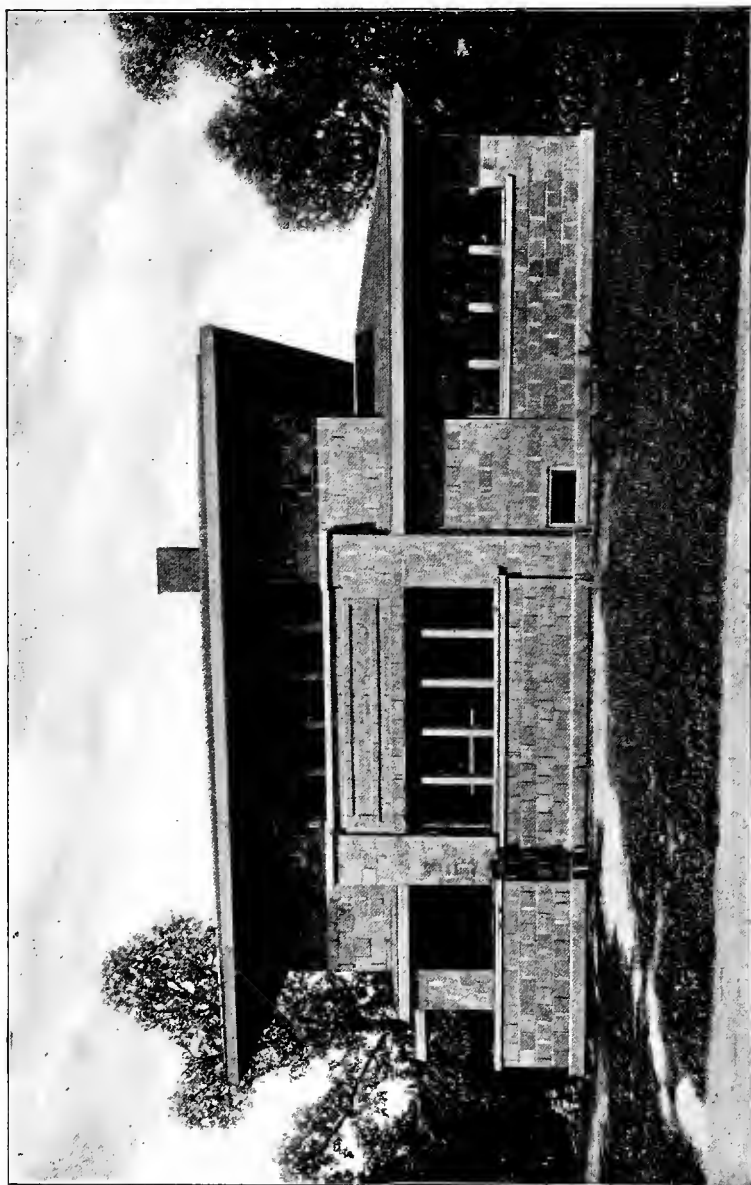

*Courtesy of the Denison Fire-Proofing Co., Mason City, Iowa*

FIG. 57



*Courtesy of the Denison Fire-Proofing Co., Mason City, Iowa*

FIG. 58

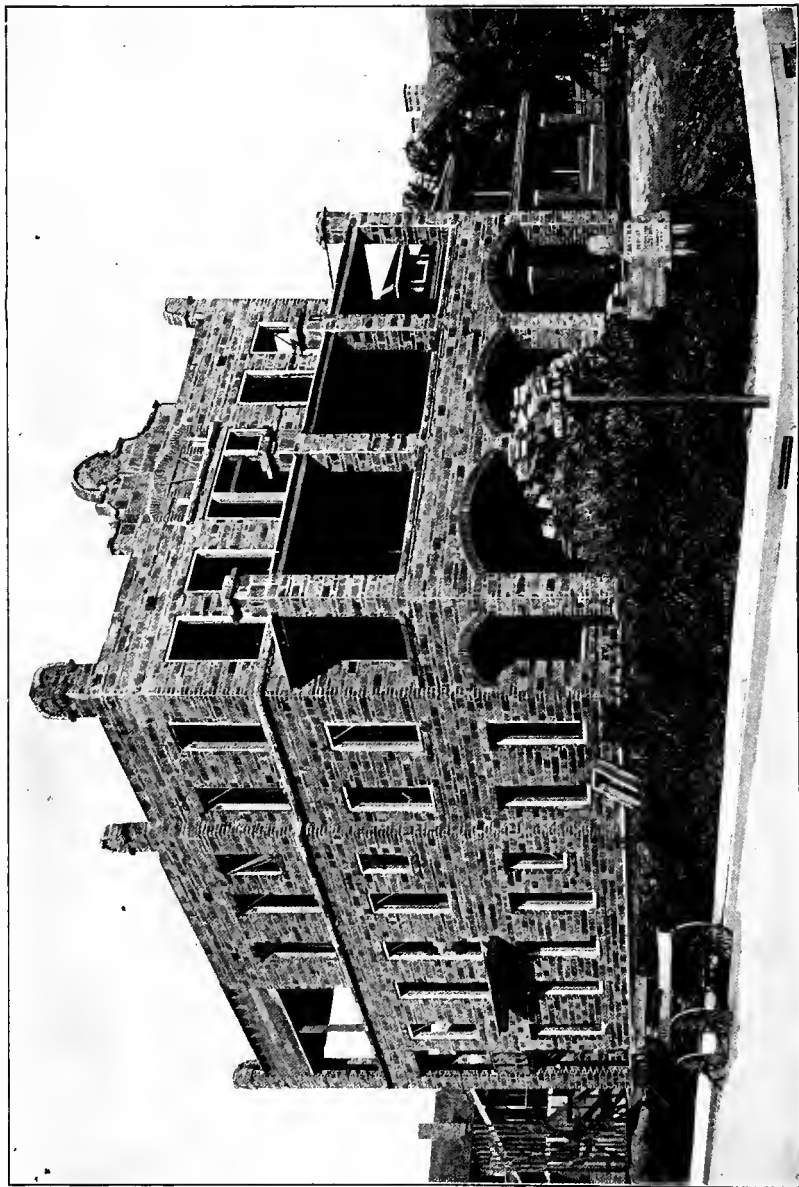

*Courtesy of the Denison Interlocking Tile Corporation, Cleveland, Ohio*  
FIG. 59

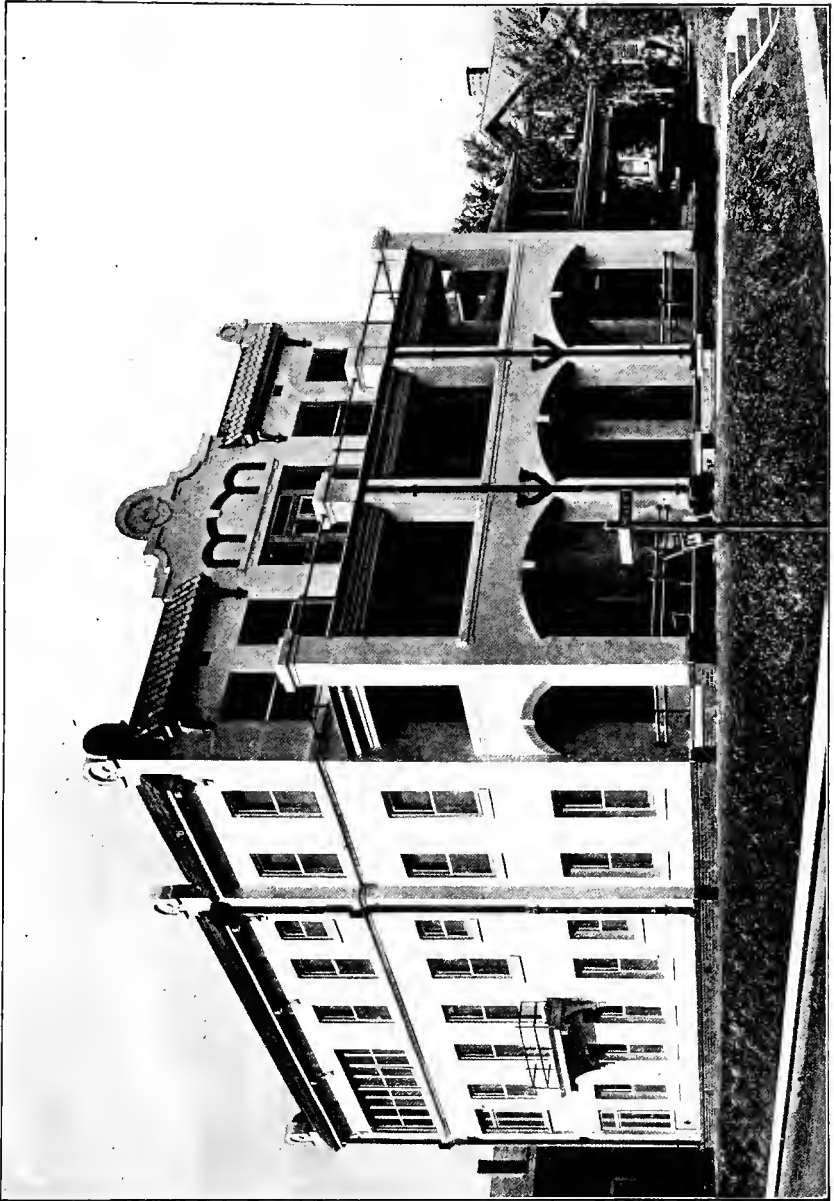

*Courtesy of the Denison Interlocking Tile Corporation, Cleveland, Ohio*  
**FIG. 60**

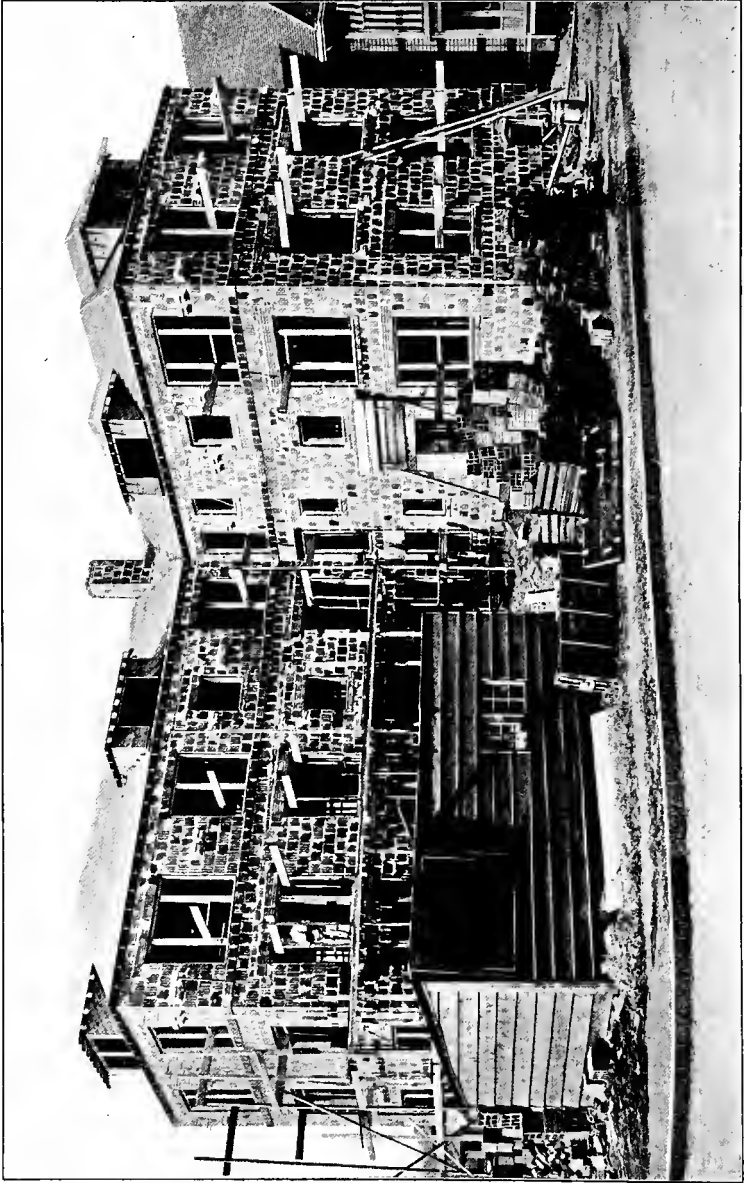

*Courtesy of National Fire Proofing Co., Pittsburgh, Pa.*

FIG. 51



shows the characteristics of hollow-tile construction. The lintels and sills are made of tiles. In some cases corner blocks and jamb blocks have not been used. The cell openings show at the window jambs and corners but will be closed up with cement mortar and will present a satisfactory surface to receive the stucco. Segmental arches are shown on the front porch and are formed of face brick, as shown in the finished building, Fig. 60.

**120.** Fig. 61 shows an interesting example of hollow-tile construction built of Natco hollow tile. The sills and lintels are of file as is also the sill course under the third-story windows. The chimney is also built of tile. Corbels of stone to receive the cornice brackets and the balconies are also shown in place. Fig. 62 shows this building finished with stucco rough cast, making a very attractive and interesting structure.

**121.** A very large apartment house is shown in Figs. 63 and 64. Fig. 63 shows the exterior walls built of Natco, or standard-shaped, tile. In this case the doorways, string-courses, and the trim of some of the windows are of stone and are built into the terra-cotta wall. The wall is shown with its stucco coating in Fig. 64. It will be noticed that the stucco in the first story has been treated to represent stone having rusticated joints. Quoins have been formed of stucco in the upper stories at the corners. The effect of this building is dignified and substantial.

**122. Factories and Warehouses.**—In factories where very heavy loads do not occur, the same form of construction can be employed as for apartments and dwellings. Instead of interior tile partitions, however, steel columns and girders may be used. The outside walls can be made of hollow tile stuccoed, left with a smooth finish of the block showing, or veneered with brick.

Many of the latest types of factories and warehouses are built with a framework of reinforced concrete, consisting of posts, girders, and slab floors. After this framework is completed the spaces between the posts and girders on the outside walls are filled in with hollow tile as shown in Fig. 65. In this

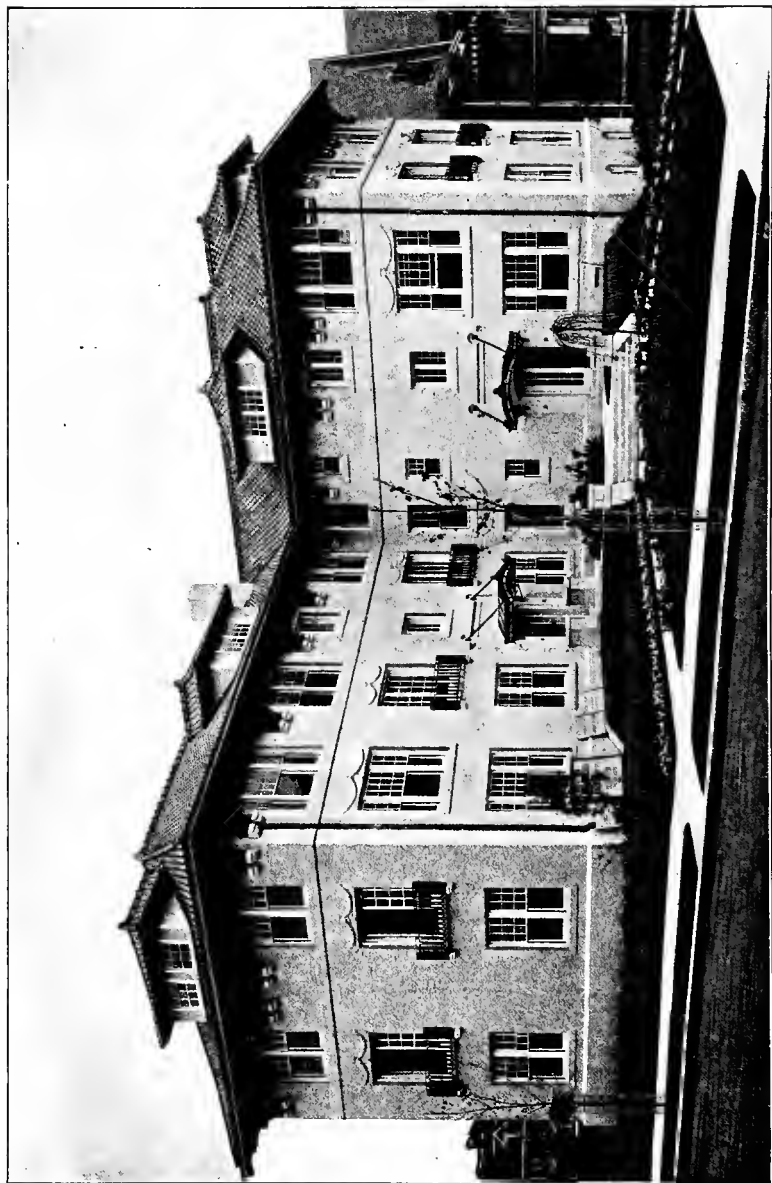

*Courtesy of National Fire Proofing Co., Pittsburgh, Pa.*

FIG. 62

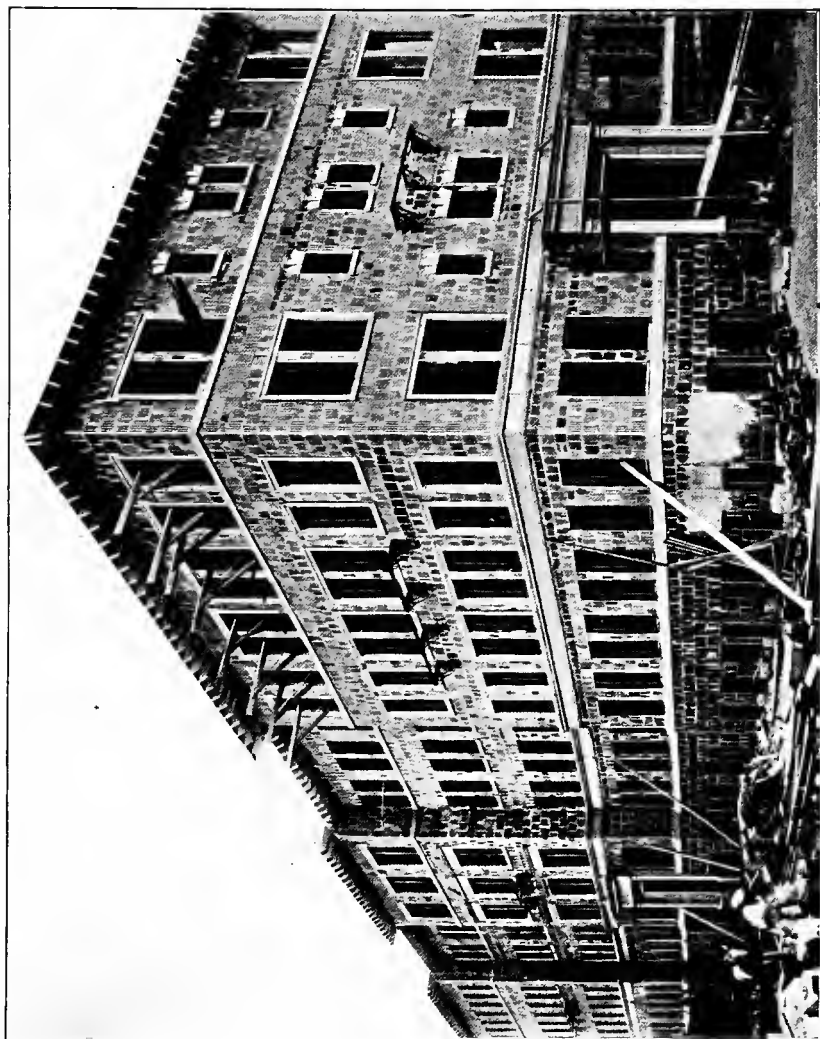

*Courtesy of National Fire Proofing Co., Pittsburgh, Pa.*  
FIG. 63

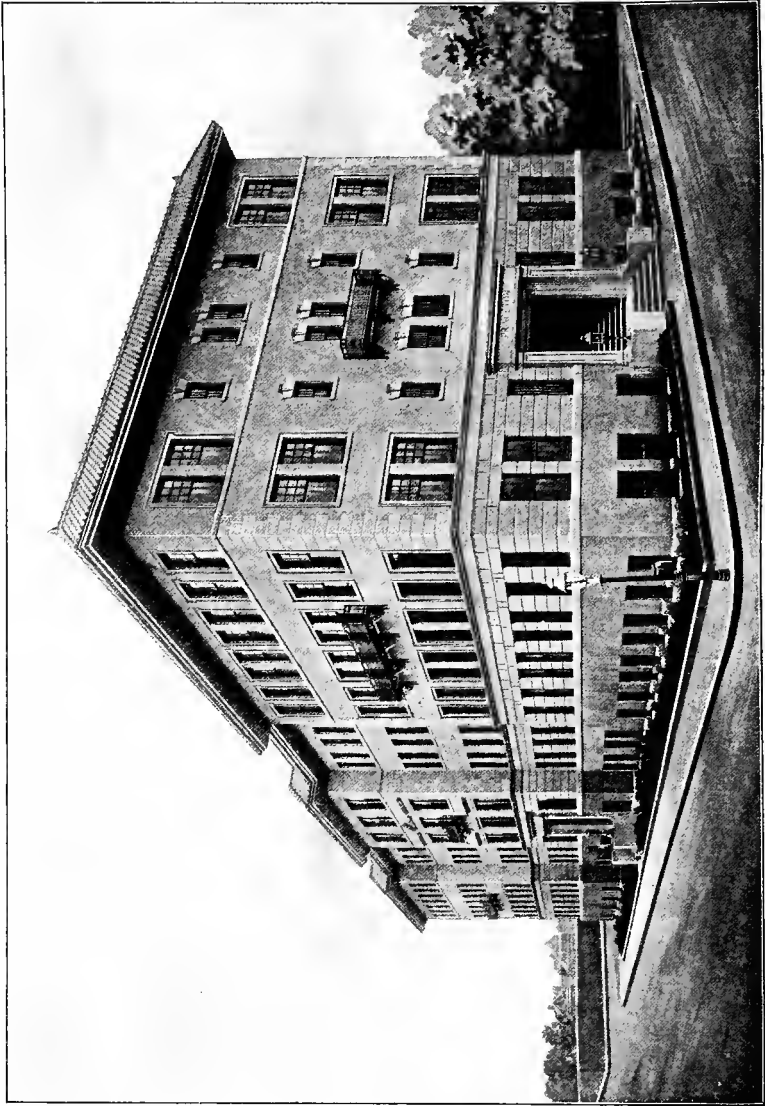

*Courtesy of National Fire Proofing Co., Pittsburgh, Pa.*

FIG. 64

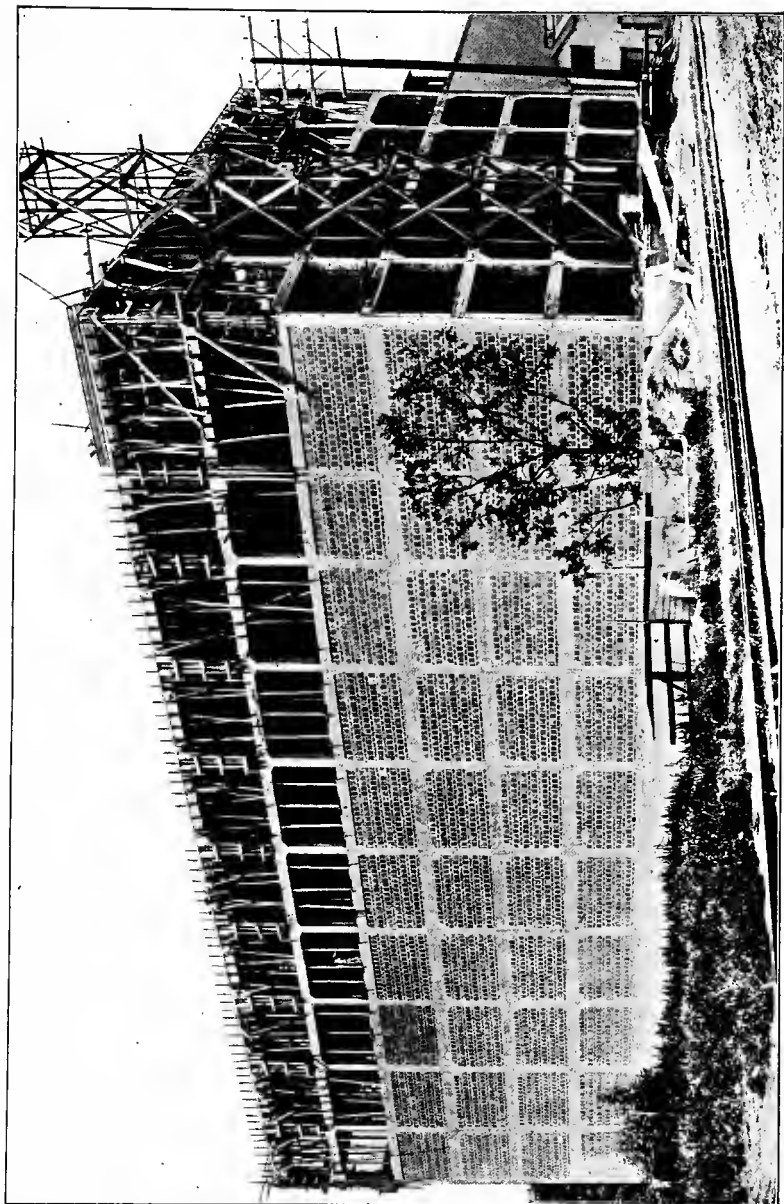

*Courtesy of the Denison Interlocking Tile Corporation, Cleveland, Ohio*

FIG. 65



*Courtesy of the Demson Fire-Proofing Co., Mason City, Iowa*

FIG. 66



*Courtesy of the Denson Fire-Proofing Co., Mason City, Iowa*

FIG. 67

case **T**-shaped, or Denison Interlocking, tile has been used. This filling-in is much lighter than brickwork and consequently does not require such heavy posts and girders to support it.

**123. Office Buildings.**—In tall office buildings, the framework is usually of steel, although in smaller buildings a reinforced framework is sometimes used. A considerable saving in weight and in the size and cost of the frame can be made by using hollow terra-cotta tile for filling in the walls between the columns and girders. These walls can, if desired, be veneered, or faced, with 4 inches of brickwork.

**124. Railroad Stations.**—An example of a railroad station built of Denison **H** tile is shown in Figs. 66 and 67. In Fig. 66 a stone base course and string-course are shown with a band of face brick between them. Above this is a hollow-tile wall. The windows are trimmed with face brick. The corners have a finish of face brick. Stone brackets and wooden brackets are built into the walls and the wall is ready for plastering. The finished building is shown in Fig. 67 and illustrates the possibilities of the use of hollow tile.



# BUILDING STONE

---

## VARIETIES AND QUALITIES OF STONE

---

### INTRODUCTION

**1. Rock** is the name given to the mass of minerals that constitute the crust of the earth. Small pieces of this rock such as are used in building construction or for other purposes are generally referred to as **stone**.

In order to decide which stone is best for use under given conditions, a knowledge of the different varieties employed in building construction, as well as the kinds available in any particular locality, is very essential. It is not necessary for an architect or builder to determine the exact composition of a stone, but his knowledge should be sufficient to aid him in selecting or specifying the kinds of stone best adapted to the purposes for which they are intended. This Section will give a general classification of the common building stones of the United States, with their composition and structure, and the qualities which fit them for use in buildings.

**2.** Stone suitable for building purposes is composed of a great number of minerals, although about 95 per cent. of the stone commonly used is composed of one or more of the following minerals: *Quartz, feldspar, mica, amphibole, pyroxene, chlorite, olivine, talc, calcite, dolomite, magnetite, hematite, limonite, and pyrite.*

**3. Formation of Rock.**—Rock has been formed in three principal ways: First, by the solidification of melted material

which formed rock such as granite and trap. Rock formed in this manner is termed *unstratified*, or *igneous*; second, by the mechanical destruction of other rock, the particles of which, together with the fossil remains of animal life, were deposited in layers in the depths of the ocean and pressed into stone by the weight of the succeeding layers of similar materials, as in the case of limestone and sandstone. Rock formed in this manner is known as *stratified*, or *sedimentary*; third, by the combined heat, pressure, and chemical action on rock already formed, resulting in the formation of such rock as marble and quartzite. Rocks formed in this manner are known as *metamorphic rocks*.

**Metamorphic rock** may consist largely of igneous rock, as quartzite; it may be composed almost entirely of the remains of animal life, as marble, or it may be a mixture of the two in any proportion. Metamorphic rock is nearly always stratified, or in layers.

4. Rock may be *crystalline*, in which the particles or grains are more or less regular in shape and arrangement, like lump sugar or rock salt. This crystallization is found in igneous rock, as in granite, as well as in most metamorphic rock, as in marble. The rock may be *amorphous*, in which the fine particles are of no regular size, shape, or arrangement, as in limestone and sandstone.

These processes of rock formation having been repeated many times in the earth's history, there is a wide variety of rocks from which stones for structural purposes may be obtained. For building purposes, however, rock may be classed as *unstratified*, or *igneous*, and *stratified*, or *sedimentary*.

---

### UNSTRATIFIED, OR IGNEOUS, ROCK

5. **Unstratified, or igneous, rock** can be distinguished by the absence of true stratification or lamination, by the absence of fossils, and by a crystalline or glassy texture in place of an earthy texture, all of which characteristics are due to conditions in which they were formed. Igneous rock has

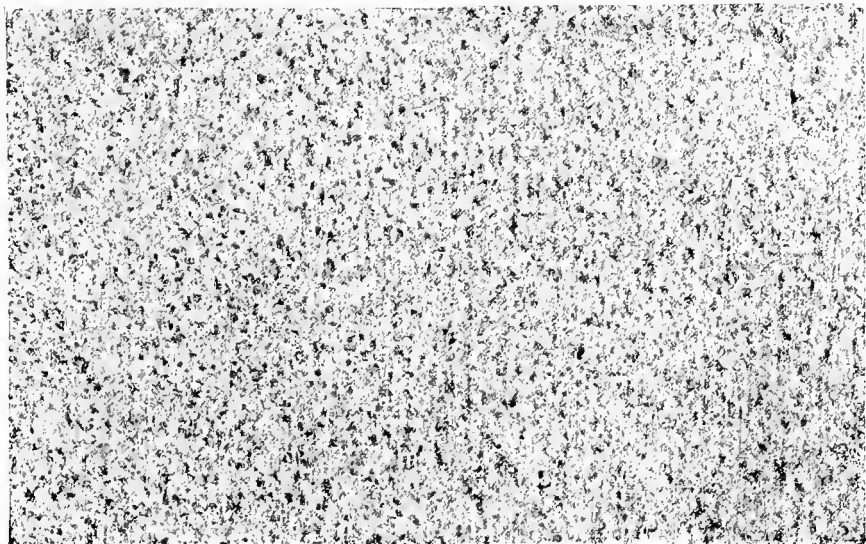

(a)

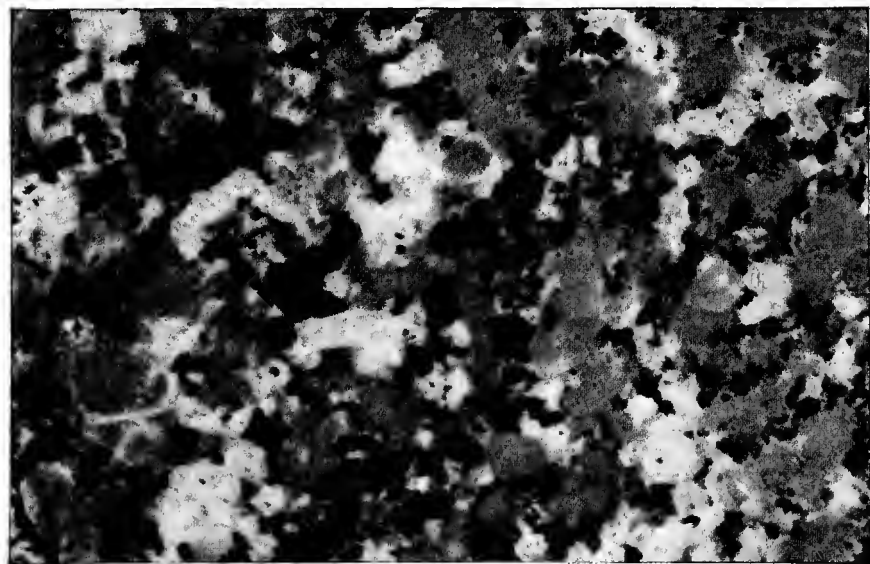

(b)

ILT 31F § 37

FIG. 1

*Courtesy of National Building Granite Quarries Association.*



consolidated from a state of fusion or semi-fusion instead of having been deposited as sediment. Its original fused or melted condition is shown by the crystallization or glassy texture. The kinds of igneous rock commonly used for building purposes are *granite*, *syenite*, *trap*, and *gneiss*.

**6.** **Granite** consists of an aggregation of feldspar and quartz crystals together with small quantities of other minerals such as mica and hornblende, and is never found in layers or strata. The color of granite is determined by the colors of the component parts, the general tones being white, gray, yellow, and red. The quality varies also with the proportions of the component parts, the hardest stone containing more quartz and less feldspar and mica than the softer varieties. The general appearance of typical samples of polished granite may be seen in Fig. 1 (*a*) and (*b*). In (*a*) is shown a granite known as Victoria White Granite, quarried at Fitzwilliam, New Hampshire, by the Milford Pink-Victoria Granite Company. In (*b*) is shown a granite known as Moose-a-bec Red Granite, quarried at Jonesport, Maine, by the Rockport Granite Company.

**7.** Granite may be quarried easily, as it cleaves or splits with regularity, and can be obtained usually in any desired size. Great difficulty is experienced, however, in working the stone, owing to its hardness and toughness. These qualities make granite very expensive to cut and undesirable when much cutting or carving is to be done. Nevertheless, it can be given a high and durable polish. The facility with which granite can be split is indicated in Fig. 2, which shows a block of granite approximately 5 feet square. The holes made by tools with which the block was split may be seen plainly at *a* and *b*.

**8.** Granite is probably the best stone for foundations, and is used extensively in other work where great strength is required. It is also put to such minor uses as flagging, thresholds, and water tables, where durability is essential.

**9.** All kinds of granite are damaged considerably by the action of fire, which causes them to crack badly. The rock disintegrates at temperatures ranging from 900° to 1,000° F.

**10.** Granite is found in the eastern and western parts of the United States and in Canada, the gray variety occurring principally in the New England states and Virginia, while the red variety, which usually is harder, is found near the Bay of Fundy, on the islands of the St. Lawrence River, in Maine, in Virginia, near Lake Superior, and in many parts of the Rocky Mountains.



FIG. 2

**11.** **Syenite** is similar to granite, but contains no quartz, which is the distinctive element in granite. Syenite consists of hornblende and orthoclase, with sometimes mica, augite, and pyrites. It has a granular texture resembling granite, is hard, tough, and somewhat coarse-grained, but will not take a polish.

**12.** **Trap** is a rock consisting of hornblende and feldspar. It breaks into blocks with ease, but has no apparent granular

structure. Owing to the difficulty of quarrying this rock in large pieces, it is seldom used as a building stone, although it makes an excellent aggregate for concrete.

**13.** **Gneiss** is very much like granite in composition, but is distinguished from it by the absence of quartz. The particles are arranged in somewhat parallel layers, and, owing to this peculiarity, the rock splits into slabs having approximately parallel surfaces, thus making it valuable for walls, street paving, and work of a similar nature. Gneiss is called *stratified*, or *bastard, granite* by quarrymen.

---

#### STRATIFIED, OR SEDIMENTARY, ROCK

**14.** Probably 90 per cent. of the rock occurring in the surface of the earth is of the stratified, or sedimentary, class. The principal rocks of this class are the *limestones* and the *sandstones*.

---

#### LIMESTONES

**15.** The **limestones** used in building construction consist of lime in combination with one or more of the following constituents: silica, clay, talc, hornblende, mica, carbonate of magnesia, and iron. Fossil remains, such as shells and coral, usually in a more or less pulverized condition, are found frequently in limestones. The term limestone is very general, and includes many varieties that differ from one another in characteristics and qualities. As not all of the limestones are suitable for building purposes, care and experience are necessary to make the proper selection.

**16.** The principal limestones used for building purposes are the *common* and *magnesian limestones*, and *dolomites*. **Common limestones** are composed chiefly of carbonate of lime, and most of them contain pulverized shells and marine fossils. Limestones containing 10 per cent. or more of magnesia are called **magnesian**, and those having over 45 per cent. of that substance are termed **dolomites**. Dolomites

are crystalline and granular in structure and usually are nearly white or of a yellowish tinge.

**17.** In color, limestones are generally light gray, blue, or buff. Good examples are obtained from Bedford, Indiana, and Bowling Green, Kentucky. Both of these limestones are very durable, and may be classed among the best building stones. Limestones, although durable, are easily stained by smoke, are easy to work, and are easily destroyed by fire.

**18.** **Marble** is a crystallized limestone, and one of the most beautiful building materials. It is used for ornamental purposes only. It is perhaps the best known metamorphic rock, having been formed from limestone by the action of heat and pressure. Marble is generally more or less translucent, and can be obtained in many varieties, the predominating colors being white, gray, red, blue, green, and black. Most marbles show a graduation in color tone, some varieties being of several tints or colors. Nearly all varieties of marble are beautifully veined with lines or streaks of variegated colors, as shown in Fig. 3. At (*a*) is shown pavonazzo marble; at (*b*), red Numidian marble; at (*c*), dark sienna marble; and at (*d*), Alps green marble. Practically all marble will take a high polish, which brings out the colors and veinings, and enhances its value. One of the most important characteristics of marble is that it is easy to carve; the closer the grain of the stone, the more suited it is to this purpose. The white fine-grained varieties are especially prized for sculpture.

**19.** Some of the best varieties of white American marble are found at Lee, Massachusetts, and in the vicinity of Rutland, Vermont. The dark-blue marble from the Vermont quarries is very durable and has a fine close grain. A handsome black marble is quarried at Glens Falls, New York. Colored marbles, including gray, light and dark pink, buff, and chocolate, are found in Tennessee, Georgia, and many other places.

Holes and cracks are found very frequently in nearly all marbles, and these defects cannot be avoided, but are overcome by filling the holes and cracks with wax colored to match the







(a)



(b)



(c)



(d)



marble. The surface of the wax will correspond to the polished surface of the marble, thus concealing the defects.

**20. Serpentine** is a rock consisting largely of magnesia, but it also contains quantities of other materials which give it a variegated appearance. One variety of serpentine, on account of its dark color and greenish veining, is known as *verdantique marble*. The prevailing color of serpentine is green, and the tone is generally dark and somber. Because of its veinings, the stone can seldom be obtained in large pieces or cut in thin slabs. It is used for its decorative value, alone or in connection with other stone.

---

#### SANDSTONES

**21. Sandstones** are composed of grains of sand, usually quartz, cemented together by silica, oxide of iron, or carbonate of lime. These grains are sometimes formed into rock by fusion, or under great pressure, and such stone is nearly as hard as quartz. This variety is known as *quartzite*, and is very strong and durable.

**22.** When the cementing material is silica, the stone usually has a light gray color; but if the grains are cemented by oxide of iron, the stone is either red or brown and is much softer. With carbonate of lime as a cement, the result is a light-colored or gray stone, which is soft and easy to work, but which does not, as a rule, weather well.

**23.** Sandstones include some of the finest and most durable stones for outside construction. The ease of working them and their wide distribution cause them to be very extensively used. Sandstone is found in a great variety of colors, such as gray, brown, buff, pink, red, drab, and blue. The color depends largely on the quantity of iron oxides contained in the stone. The presence of these oxides is not injurious, but no sandstone containing iron pyrites should be used for exterior work, as it is almost sure to become stained by rust, because of the decomposition of the pyrites.

**24.** Sandstones vary in texture from those in which the grains are almost imperceptible to those in which the particles are several inches in diameter. The finer-grained stones can be worked more easily than the coarser varieties.

**25.** Quarried sandstones usually hold much water, and this renders them soft and easy to work; but nearly all become harder as the water evaporates, and the stone should not be subjected to heavy loads until the water has dried out. Cutting and carving should be done before the quarry water has evaporated.

**26.** **Blue shale**, or **bluestone**, is a variety of argillaceous, or clayey, sandstone with a bluish color and is found



FIG. 4

in large quantities along the Hudson River, in the vicinity of Kingston, New York. It is very hard and dense, and makes an excellent material for foundations, sills, and flagging, as it splits readily into slabs of uniform thickness. Fig. 4 shows a pile of bluestone slabs. The stone is first blocked out to the desired size by means of the drill holes *a*, after which the block is split into slabs of the required thickness. Large slabs are broken up into smaller ones by first marking them deeply with a chisel, as at *b*, after which a few heavy blows along this line will cause the slab to break.

**27.** **Slate** is a silicious clay rock, containing mica, quartz, and feldspar in small fragments. The rock has been subjected

to such action as to form it into thin layers, or laminations. This formation permits the slate to be split into thin sheets, which are used for building purposes, such as roofing. Slate is also sawn into slabs of the desired shapes, which are rubbed down to a smooth surface, and used for mantels, floor tiles, steps, flagging, school slates and blackboards, and for plumbing and electrical work.

---

### QUALITIES OF GOOD STONE

**28.** „No part of masonwork, from an architectural standpoint, is of greater importance than the selection of stone for structural purposes. The qualities of stone, such as its strength and durability when exposed to variations of temperature and action of the weather, and its permanence of color, are points that should be studied with care. These qualities are best determined by actual experience. The appearance of stone after it has been exposed for several years in the quarry will give a good idea of the effect of weather upon it. Buildings, in which stone from a certain quarry has been used, will in a few years demonstrate the qualities of the stone.

**29. Weight of Stone.**—Different kinds of stone show variations in weight. In general, sandstones are lighter than limestones, and granites are heavier than either. The weight depends on the compactness, as well as on the composition, of the stone, and may vary in different parts of the same quarry. Table I shows the average weights of stones from various parts of the United States.

**30. Strength.**—Whenever a stone is to be used for foundations, piers, or bearing blocks, its strength is a matter of importance. If the stone appears to be first class, its strength may be assumed to be the average strength of stone of that kind.

**31.** The strength of stone is generally given in terms of the weight or force required to crush it. To determine this strength 2-inch cubes of the stone are placed in a machine which is capable of exerting a great pressure. This pressure is

**TABLE I**  
**WEIGHT AND STRENGTH OF BUILDING STONES**

Materials		Average Weight Pounds per Cubic Foot	Compressive Strength Pounds per Square Inch	
Granite,	Colorado .....	166	15,000	
	Connecticut .....	166	14,000	
	Massachusetts .....	165	16,000	
	Maine .....	165	15,000	
	Minnesota .....	166	25,000	
	New York .....	166	16,000	
	New Hampshire .....	166	12,000	
	Limestone, New York .....	{ Kingston ....	168	12,000
{ Garrison Sta- tion .....		164	18,000	
Indiana, Bedford, oolitic .....		146	8,000	
Michigan, Marquette .....		146	8,000	
Pennsylvania, Conshohocken ...			15,000	
Marble,	Pennsylvania, Montgomery County .....		11,000	
	Massachusetts, Lee, dolomite ...		22,800	
	New York, Pleasantville, dolo- mite .....		22,000	
	Italian .....	168	12,000	
	Vermont .....	167	10,000	
	Sandstone, bluestone .....	Connecticut, Middletown .....	148	7,000
Massachusetts ...		{ Longmeadow, brown .....	142	10,000
		{ Longmeadow, red .....	149	12,000
New York .....		{ Hudson River Little Falls, brown .....		12,000
		Ohio .....	139	10,000
Pennsylvania, Hummelstown, brown .....			8,000	
Slate .....		160-180	12,000	
			10,000	



indicated on a dial that is connected with the machine, and the pressure is noted when the stone begins to crack. The amount of pressure required to crack the 2-inch cube is then divided by 4, which is the area in square inches of a horizontal section of the stone. This gives the pressure per square inch of horizontal section. Several tests are made before the average result is determined. The result is the *resistance*, or *crushing strength*, of the stone. When this crushing strength is determined, it is multiplied by the horizontal section in square inches of any other similar stone, to determine the total crushing strength of the stone.

**32.** In discussing the crushing, or compressive, strength of stone, it is assumed that the stone has parallel horizontal beds and vertical sides, that the bottom is firmly bedded or supported, and that the load is applied uniformly over the entire upper surface. The crushing strength of such stone varies in proportion to the size of the upper surface. For example, a stone whose upper and lower horizontal beds are 2 ft.×2 ft. in size, would require four times the load to crush it that would be required to crush a stone having beds 1 ft.×1 ft. in size. The thickness of the stone is not generally considered in figuring its crushing strength, provided the thickness is not too small or too great. For instance, a block of stone subjected to a crushing force is rarely made less than 5 inches thick and, on the other hand, should not be more than ten times the least horizontal dimension in height.

In Table I are given the crushing, or compressive, strengths per square inch of various well-known building stones.

**33.** Cap and bond stones for piers carrying iron columns, and the bearing blocks under the ends of girders, should be very hard and strong stones such as granite, bluestone, or hard Vermont marble. For use in such situations, the *safe bearing strength* should not be greater than one-tenth of the crushing strength. For example, if the crushing strength of Minnesota granite as shown in Table I is 25,000 pounds per square inch, in construction the stone should be designed so as to support only 2,500 pounds per square inch. In this case, the factor

of safety used is 10, or, in other words, only one-tenth of the crushing strength is used as the safe working strength.

The stones in piers for warehouses and office buildings are often subjected to loads of from 420 to 500 pounds per square inch. Stone having a crushing strength of 4,200 or 5,000 pounds per square inch should be used for this work. By inspecting Table I it will be seen that any of the stones named therein will be satisfactory. The Chicago Department of Buildings permits a maximum loading of 600 pounds to the square

**TABLE II**  
**DURABILITY OF BUILDING STONE**

Variety of Stone	Years
Granite .....	75 to 200
Gneiss .....	50 to 200
Limestone, Ohio, best silicious .....	100 to 200
Limestone, coarse fossiliferous .....	20 to 40
Limestone, oolitic .....	30 to 40
Marble, coarse dolomite .....	40 to 50
Marble, fine dolomite .....	50 to 100
Brownstone, coarse .....	5 to 15
Brownstone, fine laminated .....	20 to 50
Brownstone, compact .....	100 to 200
Bluestone (blue shale) .....	100 to 200
Sandstone, Nova Scotia .....	50 to 100

inch, or 86,400 pounds per square foot, on first-class granite masonry laid in Portland cement mortar. Such granite masonry would possess a crushing strength of 6,000 pounds per square inch.

**34. Color.**—In places where little or no soft coal is consumed, light-colored stones may be used without any danger of becoming dirty or stained, while in very smoky cities they will get very dark in a short time. In such cases, the red or brown silicious, or flinty, sandstones are the most desirable; and next in value are the granites. The stone that retains its

natural, or native, color best is the most desirable to use; but, in localities where all classes of stone change, the one to be preferred is that in which there is the least and most uniform alteration.

Stone may be light-colored when quarried, and discolor or darken on exposure to air, while some stone becomes lighter in color on exposure to the air. Sedimentary rocks are light gray, blue, brown, buff, red, and black, while igneous rocks are usually composite in color, the general tones being white, gray, red, and sometimes green.

**35. Durability.**—The durability, or permanence, of stonework is of prime importance, as on this quality depends the life of a structure. It is desirable, therefore, that buildings should be constructed of the most durable stone that can be economically obtained.

Table II, taken from a United States census, gives the length of time that the several varieties of stone named have lasted in New York City without material deterioration.

**36.** Variations in temperature test building stone severely. Stone consists of particles cohering more or less closely. An increase in temperature expands the particles, with the result that portions of the stone are apt to separate or flake off. A lowering of the temperature contracts the particles, in which case there is a tendency for parts of the stone to separate or pull apart from the rest, forming checks or cracks. Such changes are among the most important causes of disintegration of building stone.

**37.** Frost has an injurious effect on stones saturated with moisture, as water in freezing expands with considerable force and dislodges particles of the stone. Repeated freezing and thawing will in time disintegrate the surface of the stone. Granite is the least porous of stones, and for this reason is best adapted for use in wet places which are exposed to frost.

**38.** Pure water and the dry gases of the air have but very little effect on building stone. Rain, however, often contains

traces of nitric, sulphuric, and other acids, absorbed from smoke, and other impurities in the air. These acids, when brought in contact with stone, affect its durability, through oxidation and solution of some of the mineral constituents of the stone. Where iron is present in the stone in the form of pyrites, it combines with moisture and oxygen, in the air and produces the discoloration known as *rust*.

**39.** Carbonates of lime and magnesia are present in all marbles and limestones, and are easily acted upon by atmospheric gases, the portions of stone containing these materials being dissolved out. Sandstones containing these substances suffer also from the same cause, while granites, having practically no substances affected by acids, are least affected.

**40.** Heavy pounding or hammering has a tendency to destroy the cohesion of the grains of the stone and thus render it more susceptible to climatic influences. Only granite and the hardest sandstone should be peen- or bush-hammered. The most durable finish for granite is rock-faced, as the crystalline facets, being little disturbed in the dressing, shed moisture readily. For other stone, however, a smooth surface is usually the best in localities where climatic changes are frequent. Quarrying by explosives often causes cracks that are so small as to be unseen until the application of a load makes them large enough to be visible. The fracture of stones in buildings is due more often to the method of quarrying, the treatment during the cutting, and to imperfect setting, than to any lack of strength in the texture of the stone.

**41.** For steps, door sills, and paving, the hardness of a stone is of importance, and for these purposes granite and other hard stones are most suitable.

**42.** Stones of a stratified nature should be laid on their natural beds whenever possible. In other words, the stones should be laid in the wall with the layers or stratifications in a horizontal position, as they were in the quarry. If placed so that the layers are vertical, water gets in between them much more easily, and, in freezing, very quickly splits the stone.

Stones used in sill- and belt-courses that are so placed that rain washes over them, will deteriorate much more rapidly than the rest of the masonry, and on this account should always be of the most durable kind.

Stones forming the top member of a cornice as in Fig. 5 (*b*) at *l* offer a large top surface which is almost level and affords a place for ice and snow to collect. Unless covered by some waterproof covering, such as sheet copper, as shown in Fig. 5, the stone would tend to disintegrate.

**43.** In selecting building stone, it is often important to obtain a kind that possesses good fire-resisting properties. It should be remembered that fine-grained, compact sandstones withstand fire the best, while the exposed surfaces of limestones and marbles are converted into lime by intense heat. Granites are more affected than sandstones, and less than limestones.

**44. Seasoning of Stone.**—Most sandstones and limestones, as they lie in the quarry, are saturated with water which is called *quarry water*. In order to evaporate this quarry water the quarried stones should be exposed to the air from four to six months before being used. This is called *seasoning* and makes the stone harder and more durable under the action of frost. It is supposed that the quarry water contains in solution considerable cementing material and that this is deposited when the water evaporates, firmly binding the particles together. It can be seen readily that all necessary cutting of the stone or carving on stone of these kinds can be done to advantage as soon as possible after quarrying, while the stone is still soft before the quarry water evaporates. After the quarry water has evaporated, the surface seems to have a film of very hard stone, which, if removed, renders the interior more liable to disintegration by weathering agencies.

**45.** Some contractors refuse to accept sandstone which has been exposed to freezing before seasoning. Quarries are sometimes flooded during the winter months to prevent damage from frost on quarried stone or on stone exposed in the face of the quarry.

### INSPECTION AND TESTS

**46.** A close inspection should be made of all stone before it is used, to see that the specified quality is being delivered. When large quantities are to be used, it is even advisable to visit the quarry in order to note the quality of the stone and to determine how it is affected by weather conditions.

**47.** Laboratory tests may be made on samples of the stone secured from the quarry, to determine their qualities. These tests may be *chemical*, *microscopical*, or *physical*. **Chemical tests** determine the composition of the stone. **Microscopic examination** of thin slabs of the stone will show the mineralogical composition and the state of aggregation, the presence of impurities, amount of cementing material, and the presence of cracks. **Physical tests** determine the crushing strength of the stone. Tests of this kind are sometimes made to determine the durability of the stone under various conditions, as well as to determine the specific gravity, porosity, weight, effect of heat, effect of alternate freezing and thawing, and the action of various agencies, such as carbonic and sulphurous acids. To assist in determining the qualities of stone with reference to durability and general fitness for building purposes, the tests generally made are for *absorption*, *solubility*, and *compactness*, or *hardness*.

**48. Absorption.**—The tendency of a stone to absorb water should be considered with regard to the effect on the appearance of the building. While a dense non-absorbent stone is restored to its original color by a heavy rain, one of open texture will quickly absorb the water, which carries dust and soot into the pores of the stone and soils it in a short time.

Generally, the most durable stones are those that absorb the least water. In order to test the absorptive qualities of a stone, a good average specimen should be thoroughly dried, carefully weighed, and immersed in water for 24 hours. When taken out, the surface moisture should be dried off and the piece again weighed; from the gain in weight, a good idea of the value of the stone may be obtained. One that increases

10 per cent. in weight in 24 hours should be rejected, unless it can be proved that such stone has endured successfully the tests of time and weather, as described previously. One absorbing even 5 per cent. of water and containing a large proportion of clay is undesirable from the standpoint of permanence.

**49. Solubility.**—To determine whether a stone contains much matter that is earthy and easily soluble, a sample of the stone should be crushed finely and placed in a glass of water and the particles allowed to remain undisturbed for about half an hour. At the end of this time, stir thoroughly the contents of the glass. If the stone contains much earthy matter, the water will assume a turbid or cloudy appearance, and if it has only a small quantity, the water will remain clear.

**50. Compactness, or Hardness.**—The densest and strongest stones are generally the most durable. An idea of the compactness may be obtained by examining, through a good magnifying glass, the faces of freshly fractured stones. These should be clear and bright, and the particles well cemented together. A dull, earthy-looking fracture indicates liability to quick deterioration, and if the stone gives forth a clear metallic sound when struck with a hammer, it is conclusive proof of its compactness.

**51.** As already stated, the air in industrial communities is very likely to contain traces of various acids that attack the stone when it is washed by the rain. To determine the probable effect of acids on a particular kind of stone, soak a sample of it in a dish of water which contains a drop or two of muriatic or sulphuric acid. If there is a very noticeable bubbling, it will be wise to test the stone chemically and compare the result of the analysis with the analysis of similar well-known stones. This work should be done by a chemist or mineralogist.

Any undesirable variation in the color or texture of the stones can generally be seen by a careful inspection of the stones. Stones that are objectionable in color or too coarse in texture can be rejected and removed from the site.

## STONE CUTTING AND FINISHING

**52.** The art of stone cutting consists of making templates or patterns from which any stone can be cut and of cutting the stones to match these templates. These templates or patterns will be described later. Stones having carefully made joints and beds and which are accurately fitted into walls or other masonry construction, constitute what is known as **cut-stone work**. The stones themselves are called **cut stone**.

Cut-stone work is, as a rule, confined to the facing of walls which are backed by a cheaper material, and when the stone is so used it is referred to as **ashlar**. The methods used to produce such stonework are briefly described in the following pages.

---

### DRAWINGS

**53. Architect's Drawings.**—In designing the façade, or front, of a building that is to be finished in ashlar, the architect generally lays out all the stones on his drawings with considerable care. The stones should have a pleasing shape, and be neither too large nor too small. The drawings of some details, such as moldings, cornices, and carvings, are usually made full size, so that the intention of the architect may be clearly understood, and as little as possible be left to the judgment of the stonecutter.

**54.** Fig. 5 (*a*) illustrates a portion of an architect's drawing of a building front finished in cut-stone work. The joints, as well as the moldings and ornamentation which are cut on the different stones *a*, *b*, *c*, *d*, and *e*, are all shown. The stone *f* is cut to receive the arch stone *g*. At *h* is shown a section through the stone jamb, indicating the form of the molding which is to be cut on the jambs of that window.

**55.** In (*b*) is shown a section through the front of the building on the line *x-x*, Fig. 5 (*a*). This line cuts the key-



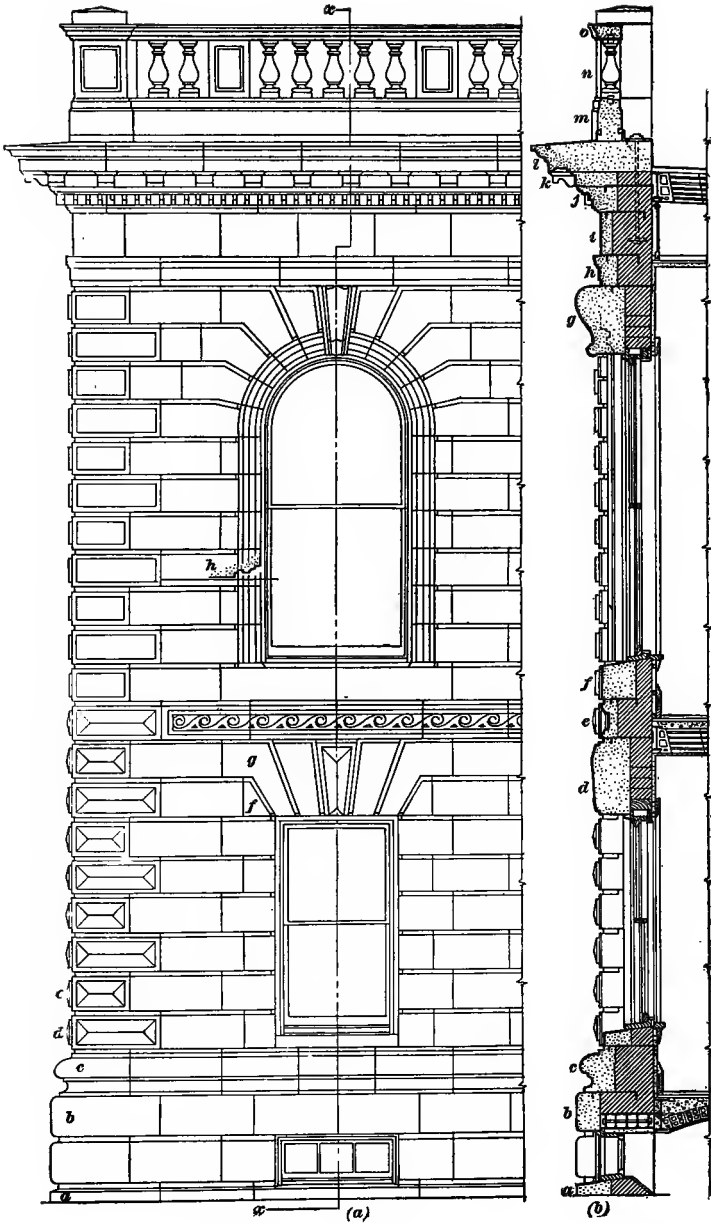

stones of the arches in the first and second stories, and also the lintel over the basement window. A section through the basement sill is shown at *a*, and through the basement lintel at *b*. At *c* the section line cuts the string-course below the first-story window sills. A section through the keystone of the arch over the first-story window is shown at *d*, while *e* shows a section through the string-course below the second-story sill *f*. A section of the keystone of the arch over the second-story window is shown at *g*; and it will be noted that the outline of the jamb is shown in dotted lines at this point,

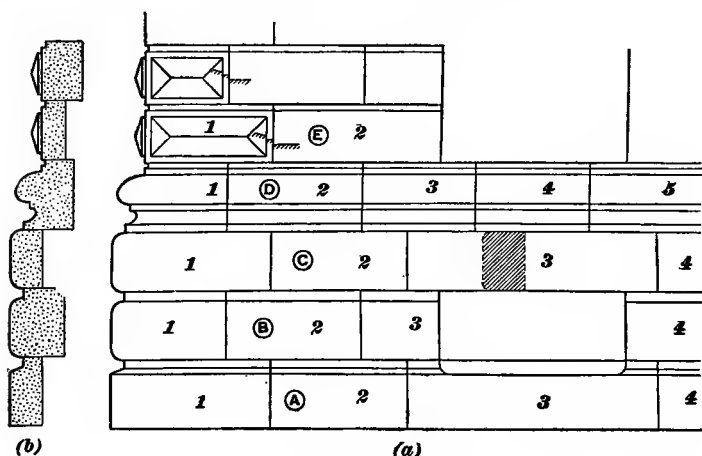

FIG. 6

as the circular jamb fits against the keystone. A section of the entablature is shown at *h*, *i*, *j*, *k*, and *l* and above this is a section through the balustrade at *m*, *n*, and *o*.

**56. Stonecutter's Drawings.**—From the architect's drawing, Fig. 5, the stonecutter makes a drawing, a portion of which is shown in Fig. 6, from which the stone is cut and also from which the stone is set in the building. In this drawing, in (*a*), each course is given a letter, beginning with *A* at the bottom course. The stones in each course are numbered from left to right, each being given a specific number as shown in the figure. This number, and the letter showing the course

are painted on the back of the stone for identification. When several of the stones are identical in shape and finish, the marking is sometimes repeated for each of them, so as to avoid the use of high numbers, and to avoid the necessity of looking for a stone having a particular number when there may be many others of the same size and finish available. A section through the cut-stone work is shown in (b).

**57. Templets.**—A *templet*, or *pattern*, is made for each different design of stone, and consists of a form cut out of sheet metal, cardboard, or heavy paper, showing the profile of any moldings or recesses in the stone. In Fig. 7 is illustrated a templet such as would be used for the stone course *A* in Fig. 6. This templet shows the profile of the exposed cut surface of all similar stones in this course. In laying out a stone, the top and bottom surfaces *a* and *b* are made parallel and straight, and the shape of the templet is



FIG. 7



FIG. 8

marked on the end of the stone. The stone is then put into the planing machine, which will be described later, and is cut to this profile throughout its entire length. A similar templet is shown in Fig. 8 for the stone in the course *D* in Fig. 6. Special templets are made for the stones with special shapes, such as the keystone in the second-story window. The shapes or profiles of all these special stones are obtained from the full-size drawings, which are made in the architect's office and sent to the stonecutter for his guidance.

### CUTTING STONE BY MACHINE

**58.** Most of the cutting of stonework for buildings is done in stone yards by machines. These machines are arranged generally in one of two different ways. In one case they are arranged in a rough circle around a central derrick, as shown in Fig. 9. In this figure the arrangement of the yard is roughly indicated, with the various machines located at *a*, *b*, *c*, *d*, and *e*, and piles of stone at *f*, *g*, etc. All of these are readily reached

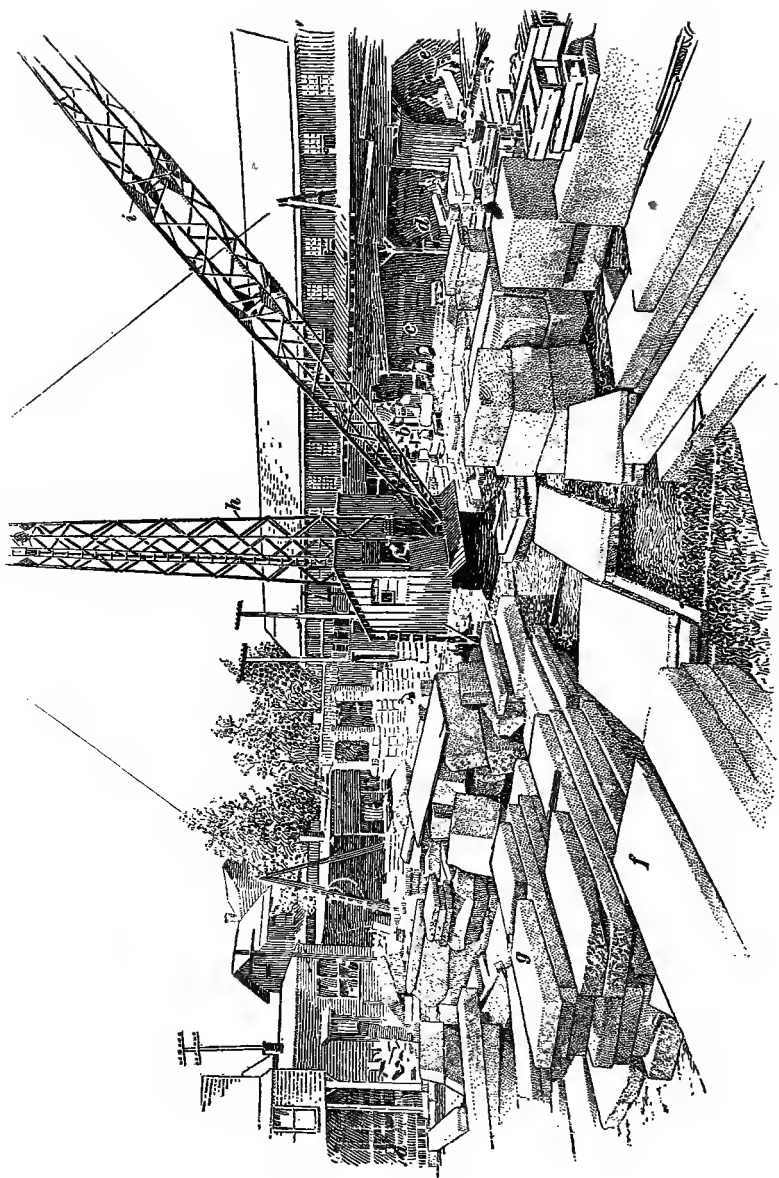

FIG. 9

by the derrick *h*, which, by means of the boom *i*, lifts the stone from the piles at *f* and *g* and deposits it on the beds of the various machines and also removes the finished work from the machines and deposits it on the wagons to be shipped away, or in other positions where further cutting may, if necessary, be done upon it. Another type of stone yard or shed is that in which there is a traveling crane which moves back and forth along the length of the yard or building. In this case, the machines may be placed at any convenient point in the building and still be properly served by the crane. The principal machines used in stone cutting are *saws*, *planers*, *lathes*, *grinders*, *polishers*, and *pneumatic tools*.

#### SAWS

**59. Gang Saws.**—The gang saw illustrated in Fig. 10 is one generally used to cut rough stone into small portions and is used particularly on hard stone like granite. These machines

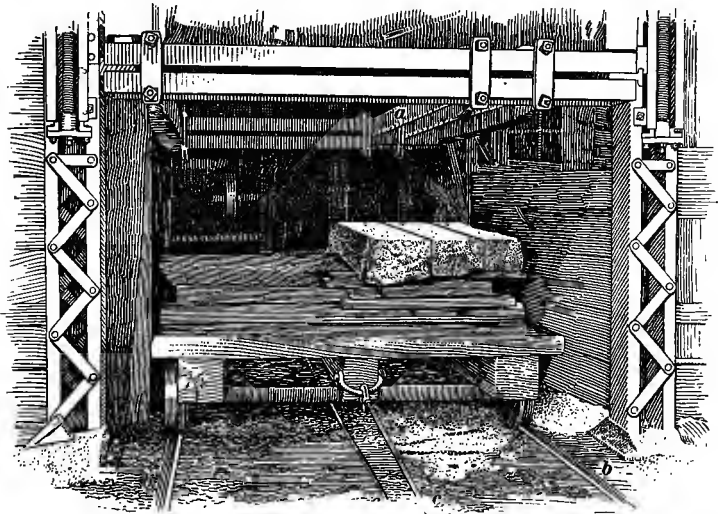

FIG. 10

consist of saws *a*, which are long bands of steel with their edges cut to form rectangular teeth. These saws are drawn back and forth through the stone in the same manner as a

carpenter's hand saw, the work, however, being done by power. The stone is firmly supported by wooden blocks upon a bed, or truck, which runs on tracks *b*, and is pulled back and forth by means of ropes *c*, attached to the platform. When the stones have been cut as shown in the figure the saws are raised, the truck is pulled out from under the saw, and the pieces removed from the platform by means of the derrick. While the saws are working in the cuts in the stone, hardened steel shot is introduced in these cuts, and assists in cutting the stone. Water is poured continually into the cuts to absorb the heat

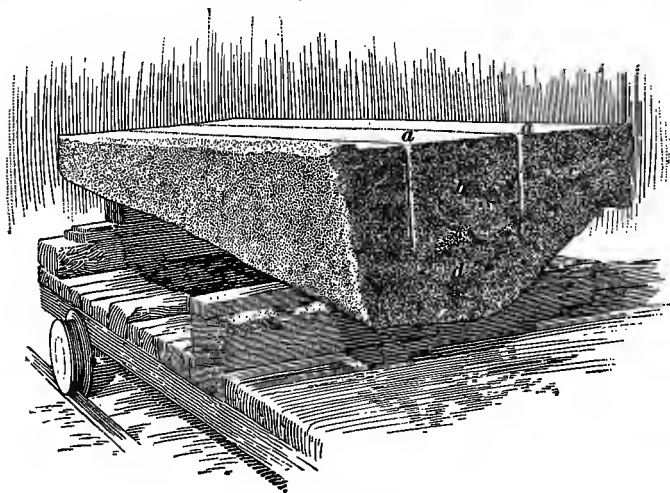

FIG. 11

generated by friction and also to remove the stone dust from the cuts. Fig. 11 shows the other end of the stone shown in Fig. 10, after it has been machine-sawed and withdrawn from underneath the saw. The saw cuts *a* are deep enough to furnish the stones *b* and *c*, of the required size, and to permit the stonecutter to split the block along the line of the saw cuts. The material below the saw cuts, as at *d*, is superfluous material which will be discarded when finishing the stones to size.

**60. Diamond Saws.**—Diamond saws are circular blades of steel, in the edges of which are placed diamonds of a black-

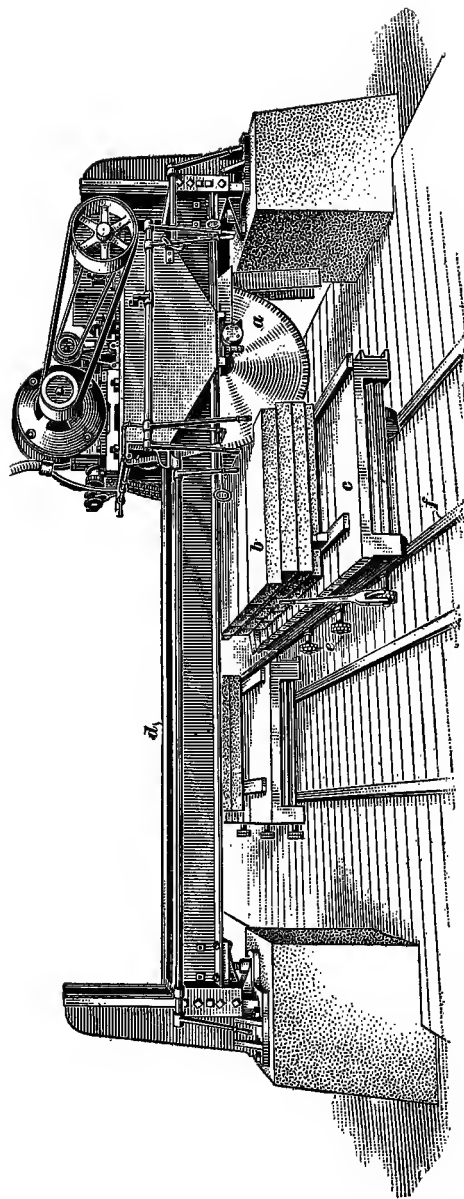

Fig. 12

ish color. These diamonds take the place of the teeth of the ordinary saw and, when the saw is revolved rapidly, the stone is cut with great facility and speed. Such a saw is shown at *a* in Fig. 12. Four slabs of stone *b*, on a truck *c*, are being cut at one operation. The saw is arranged to travel across the frame *d* of the machine, and the truck may be locked by the brake *e* to the rails *f* at any desired point.

In another style of machine, Fig. 13, the stone *a* is fastened to a bed *b*, which travels past the saws *c*. The saws may be moved to any point on the supporting member *d*, which may

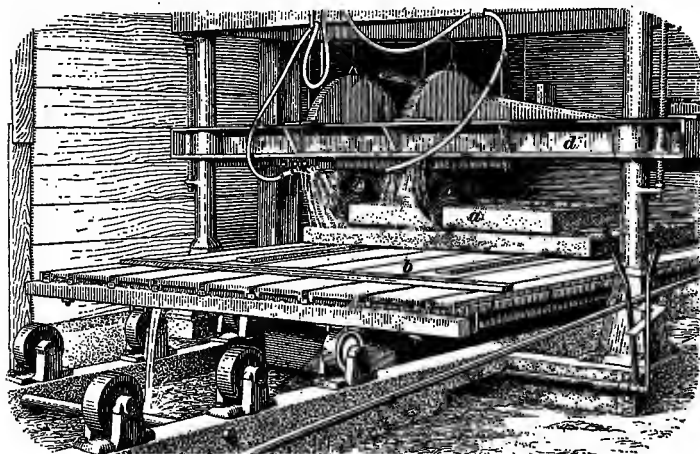

FIG. 13

be raised or lowered as desired. Streams of water directed against the sides and edges of the saws keep them cool.

**61. Carborundum Saws.**—Carborundum saws are circular saws of steel which have teeth made of carborundum instead of being fitted with diamonds. These saws are very effective and are used in the same manner as diamond saws.

**62. Band Saws.**—Band saws are similar to the band saws which are used for woodwork, the cutting edge running downwards in a vertical direction. The cutting is done by the aid of sand or carborundum, and water, that are introduced into the cut during the sawing process.



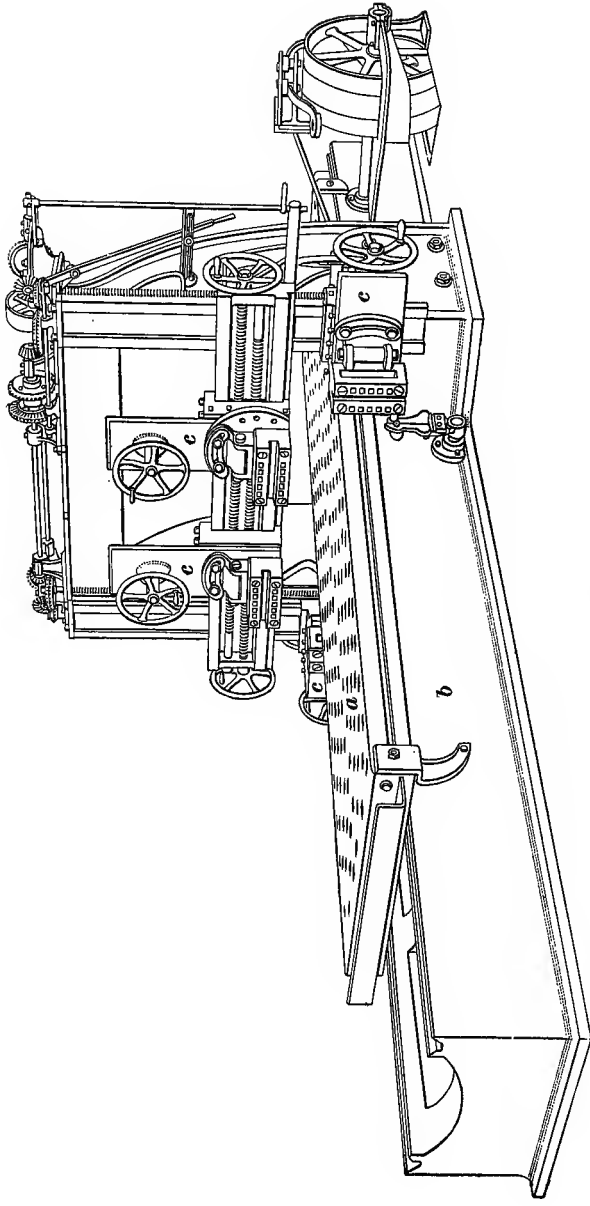

Fig. 14

## PLANERS

**63.** A planer consists essentially of a heavy sliding bed of steel *a*, in Fig. 14, on a foundation *b*. To the bed *a*, the stone to be planed or molded is securely fastened by blocks which are inserted in holes in the plate. Tools suitable for cutting the molding required are firmly held in the heads *c*, and the plate *a* is set in motion, forcing the stone against the edges of these tools, thus scraping off the surfaces of the stone to the desired shape. These tools can be moved up or down or side-wise as may be desired. Planers are used generally where

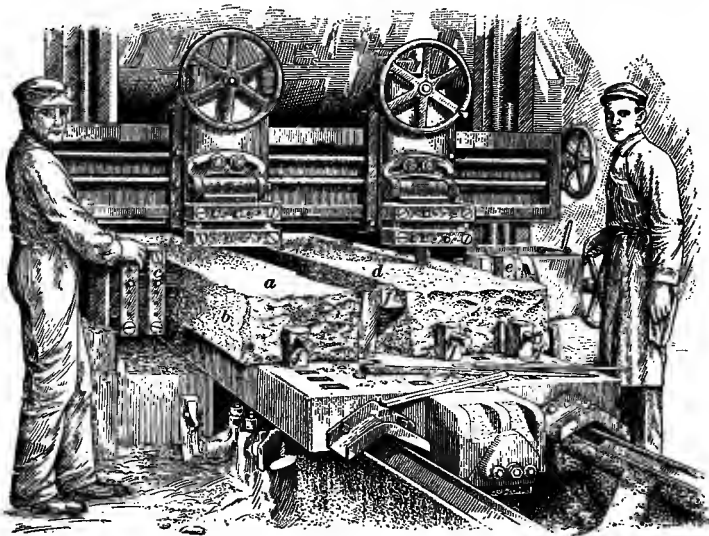

FIG. 15

the moldings or surfaces are perfectly straight, but where moldings are to be run on a curved surface the work may be done on a somewhat similar machine arranged to do that kind of work. In Fig. 15 two pieces of stone are being planed at one time, on a machine similar to that shown in Fig. 14. The stone *a* has the top surface finished and the side *b* is being finished by the tool *c*. The stone *d* has the tool *e* dressing the side, while a similar tool is finishing the face or top. The stones are held in place by the blocking at *f*.

## LATHES

64. One style of lathe, shown in Fig. 16, may be used for turning columns, balusters, and similar work. The stone, held between the centers of the headstock *a* and the tailstock *b*, and revolved against the cutting tool *c*, inserted in the toolpost *d*, is pared down to the required size. Lathes are made in various sizes, the one shown being capable of turning columns 66 inches in diameter and 24 feet long. Attachments are provided for fluting when desired.

FIG. 16

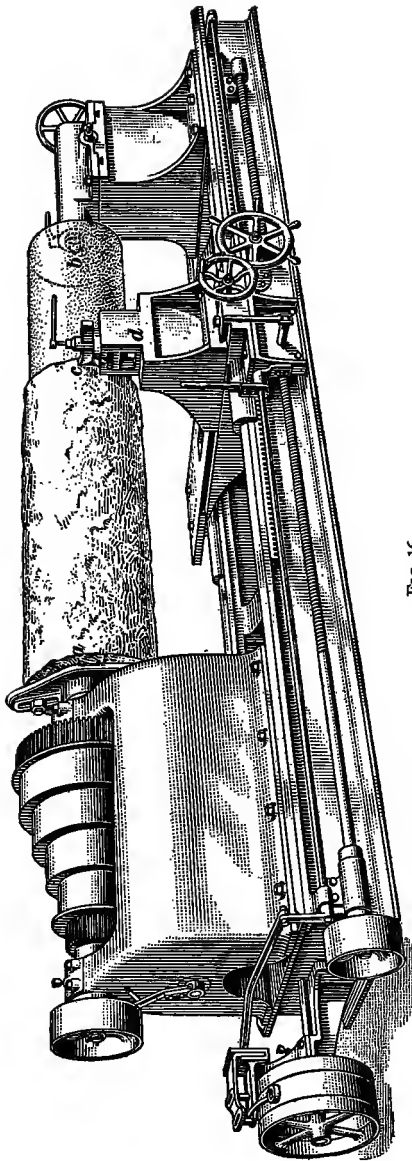

## POLISHERS

65. One form of polisher, or polishing machine, is illustrated in Fig. 17. This machine consists of a pedestal *a* and a horizontal arm *b*. On the lower extremity of this arm is a disk *c*, which is fitted with carborundum blocks. This disk is revolved rapidly by means of belts worked on the

pulleys *d*. The belts are omitted from this figure for the sake of clearness. The rapidly revolving disk is applied to the surface of the stone *e*, as shown, and can be moved to any part of the stone by means of the handle *f*, thus polishing the entire surface of the stone.

Another type of polishing machine consists of a fixed bed similar to that used in a planer, to which the stone to be pol-

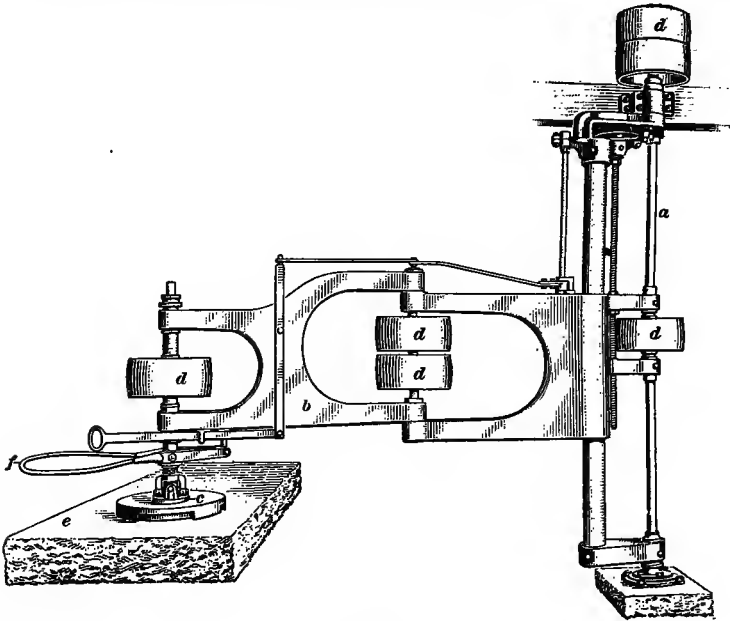

FIG. 17

ished is secured by blocks and wedges. Circular disks having carborundum surfaces are revolved rapidly over the surface of the stone, producing the desired polished or rubbed effect. Machines of this type are used principally for polishing granite and marble.

#### PNEUMATIC TOOLS

**66.** Pneumatic tools, shown in Figs. 18, 19, 20, and 21, are used to a large extent in modern stone yards, especially for cutting granite, marble, and bluestone. Pneumatic tools, as

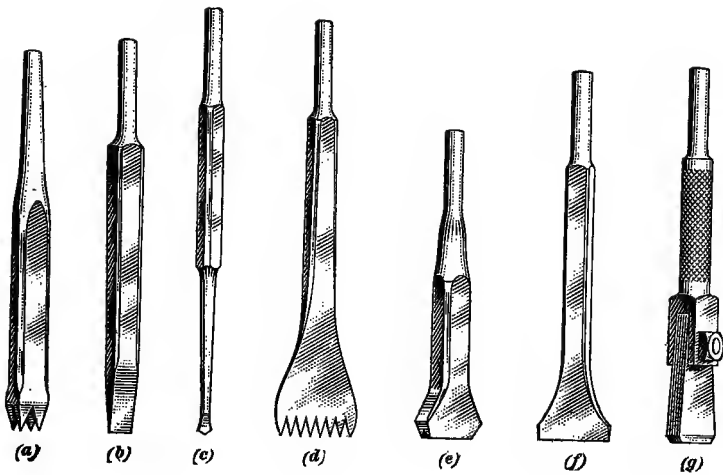

FIG. 18

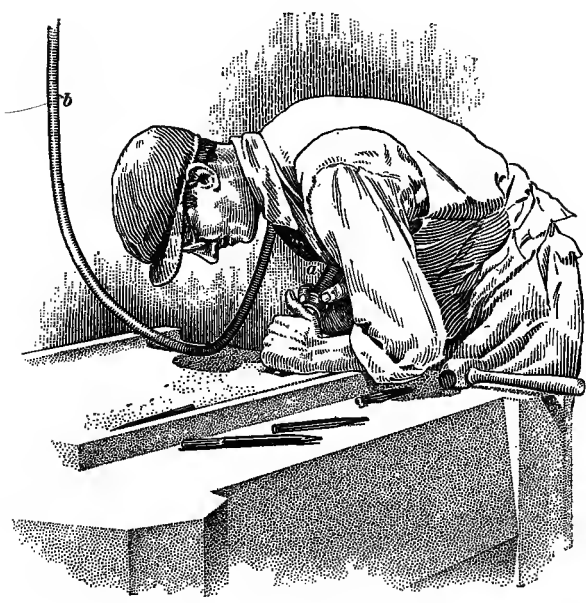

FIG. 19

shown in Figs. 19 and 20, consist of steel cylinders *a*, with movable pistons or hammers worked by air pressure, connected with air-compressing engines by means of a stout hose *b*, through which the compressed air is conveyed. Tools of various types are shown in Fig. 18, and these tools can be placed in the opening in the cylinder and driven by a succession of extremely rapid blows which cut the stone much more rapidly than it can possibly be done by hand.

In (*a*), Fig. 18, is shown a *tooth chisel*; in (*b*), a *plain chisel*; in (*c*), a *carver's drill*; in (*d*), a *marble tooth chisel*; in (*e*),



FIG. 20

a *double-bladed chisel*; in (*f*), a *cleaning-up chisel*; and in (*g*), a *bush chisel*. The general method of using these tools may be seen in Figs. 19 and 20.

**67.** A heavier type of pneumatic tool or stone dresser mounted on a pedestal is shown in Fig. 21. The tool holder *a* may be moved to any part of the hinged arm *b*, which may be raised or lowered on the pedestal *c*. This form of mounting takes the weight of the device from the operator and allows him to give his whole attention to directing the edge of the cutting chisel *d* to any part of the stone to be dressed.

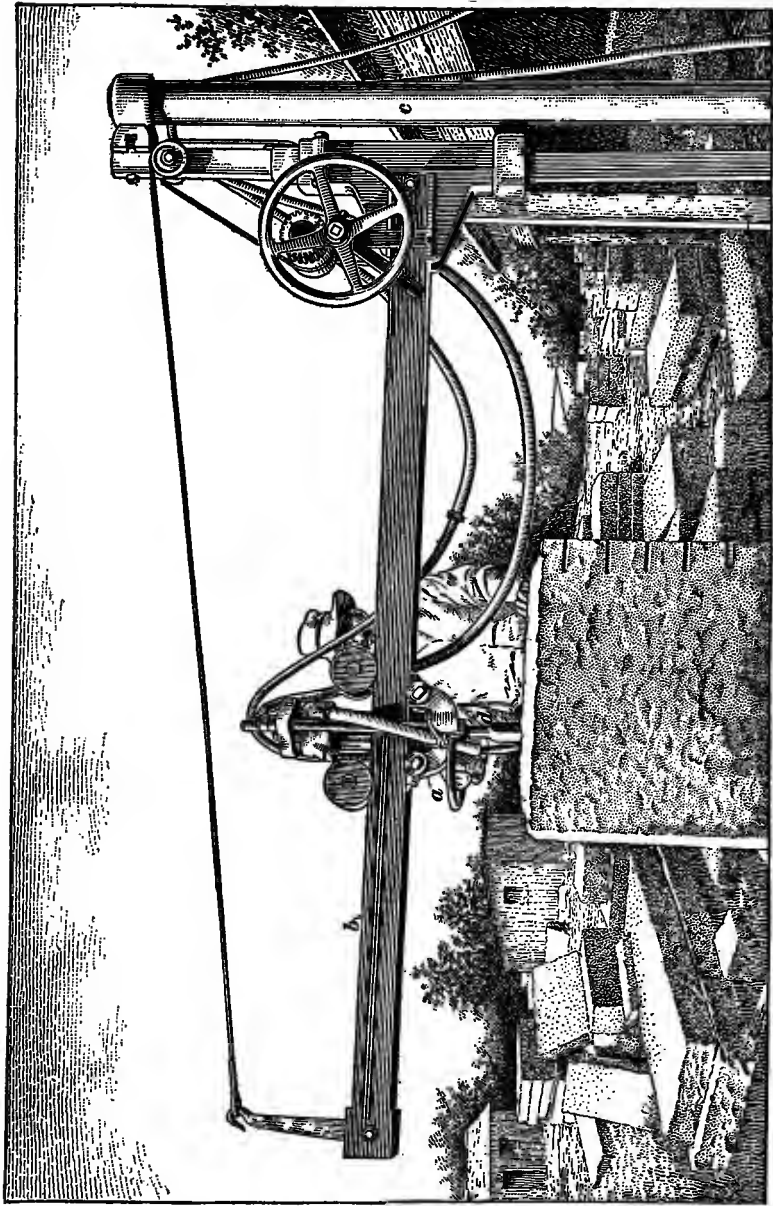

FIG. 21

**68.** Pneumatic tools, while suitable for granite, marble, and bluestone, are not considered satisfactory for use on limestone or other soft stone, as their action is rather severe for these softer stones. They are used sometimes, however, for roughing out such stones.

---

#### CUTTING STONE BY HAND

**69.** As far as possible, the stone is cut by machinery. There are, however, cases where it is necessary to do considerable cutting by hand. Round or curved work in limestone is generally cut with hand tools. Hand tools are also used in fitting stones as they are about to be placed in the building after having been delivered from the stone yard. On a good-sized building one or two stone masons are kept busy constantly, cutting and fitting stones for the masons to set when they are erecting the stonework on the building. This is necessary, particularly on a building having a steel framework, where the backs of the stones must be cut out to fit in against the steelwork. A brief description of some of the hand tools that are used for cutting stones at the building and in the stone yard is given in the following pages.

---

#### HAND CUTTING TOOLS

**70. Hammers and Mallets.**—Masons' hammers are made of steel and are used for breaking and roughly shaping the stones as they come from the quarry. The **double-faced hammer** is shown in Fig. 22 (*a*) and weighs from 20 to 30 pounds. The **face hammer**, shown in (*b*), is a lighter tool than the double-faced hammer, weighing from 12 to 16 pounds, and is used for the same purposes as the double-faced hammer when less weight is required. It has one blunt and one cutting end, the latter being used for dressing the stones roughly preparatory to using the finer tools.

The **stone pick** shown in (*c*) is used for dressing the softer stones coarsely; its length is from 15 to 24 inches, and the thickness at the eye is about 2 inches.



The **peen hammer** shown in (d) is about 10 inches long, and has two cutting edges about 4 inches in length; it is used for making *drafts*, or margin lines, around the edges of stones, and for dressing the faces.

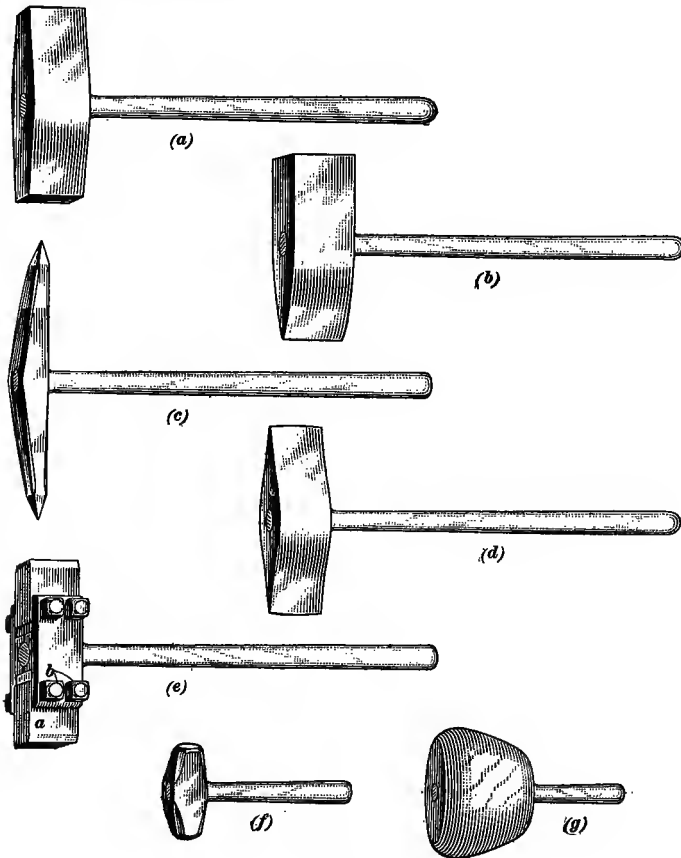

FIG. 22

The **bush hammer** shown in (e) is made of from four to ten thin blades of steel *a*, which are ground to an edge and held together by bolts *b*, so as to form a single tool. This hammer is used for finishing granite or hard limestone. The number of blades to the inch determines the fineness of the cut, which is specified as four-, six-, eight-, or ten-cut.

In (f) is shown a **mason's hand hammer**, which weighs from 2 to 5 pounds and has a short handle. It is used with

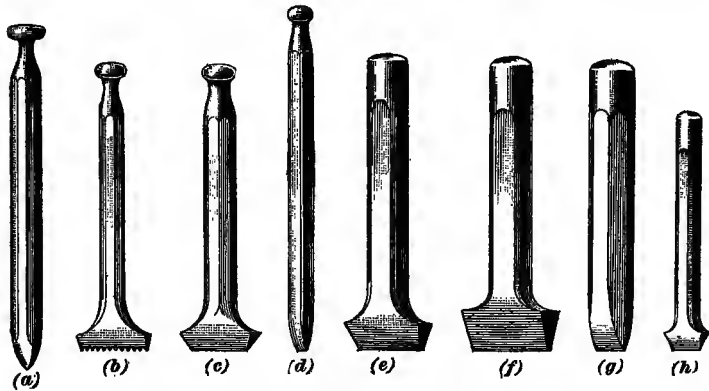

FIG. 23

various tools for drilling holes, and for pointing, pitching, and chiseling the harder stones.

The **mallet** shown in (g) is used in cutting soft stones. It is made of hickory wood, the head being about 7 or 8 inches in diameter and 5 or 6 inches in height.

**71.** In Fig. 23 (a) is shown a **point**, which is a tool made of round or octagonal steel, 8 to 12 inches long, with one end pointed. The point is used in chipping off the rough faces of the stone and reducing them to approximately plane surfaces.

The **tooth chisel** shown in (b) is used on marble and sandstone to reduce the surfaces that have been partially leveled by the point.

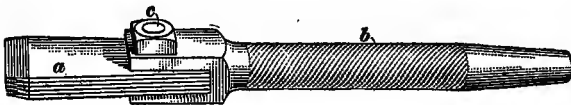

FIG. 24

In (c) is shown a **pitching tool**, made of steel,  $\frac{3}{4}$  to  $1\frac{1}{4}$  inches in thickness. It is used to form straight edges on stones.

In (d) is shown an ordinary **chisel**. Chisels are used in smoothing off the rough surfaces of stone and are made with cutting edges that are from  $\frac{3}{4}$  to  $1\frac{1}{2}$  inches in width.

The tools shown in (a), (b), (c), and (d) have *mallet heads* and are driven by means of the mallet. Other forms of chisels with plain heads are shown in (e), (f), (g), and (h) and are driven with steel hammers.

The **hand bush chisel** shown in Fig. 24 has a number of blades *a* held in the shank *b* by means of the bolt *c*, and is used in places that cannot be reached with the bush hammer.

### FINISH OF STONEMWORK

**72.** In the architect's drawings the stones and the joints between them are shown. The stonemason makes a detail of each stone and cuts it to fit exactly against the adjacent stones. The finish of the exposed surfaces of the stones is specified by the architect. A few of the more common finishes that are specified will be described in the following pages.

**73. Rock-Faced Work.**—In Fig. 25 is shown **rock-faced**, or **pitch-faced**, work, and the method of using the pitching chisel. The face of the stone is left rough, just as it comes from the quarry, and the joints, or edges, are pitched off to a line, as shown at *a*. As very little work is required for this finish, rock-faced dressing is cheaper

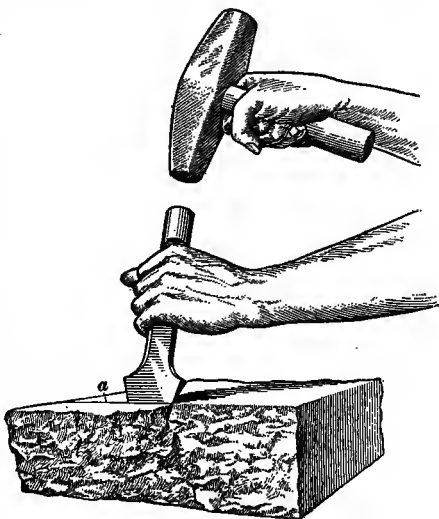

FIG. 25

than any other kind, especially when granite, bluestone, or hard limestone is used. Care must be taken, however, that no tool marks show on the finished surface of the stone. An example of rock-faced bluestone is shown in Fig. 26. The methods of laying up this work are treated in another Section.

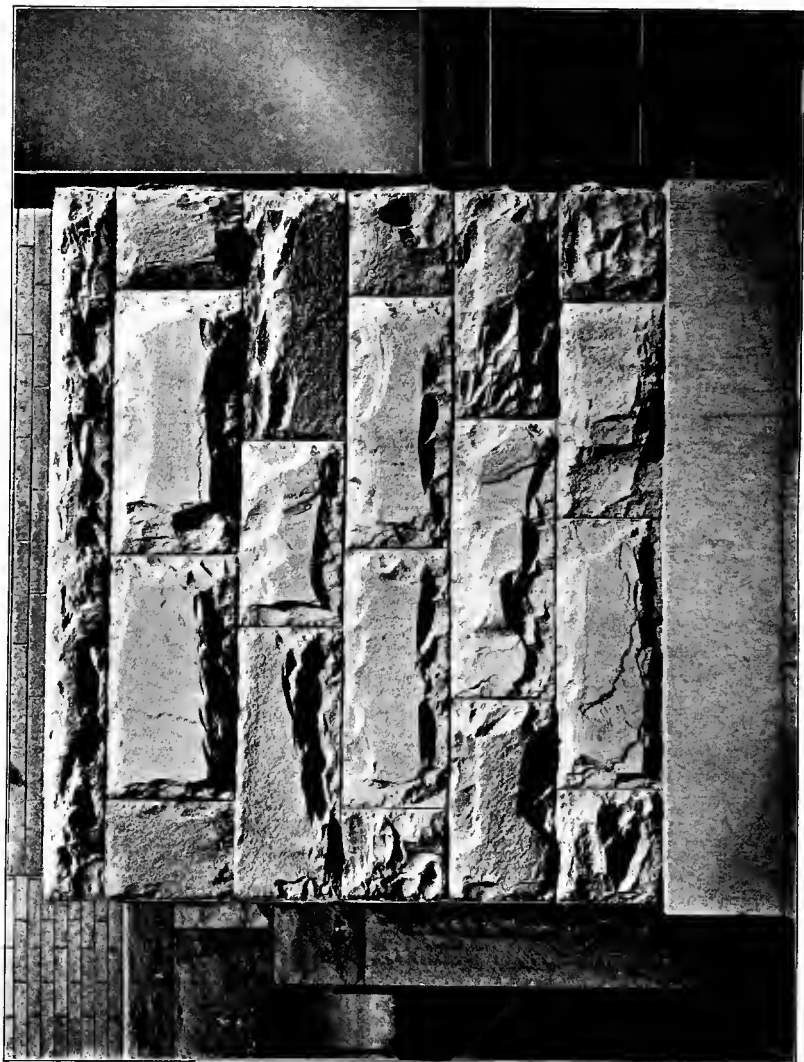

FIG. 26

**74. Pointed Work.**—An example of **pointed work** is shown in Fig. 27. This effect is produced by taking off the

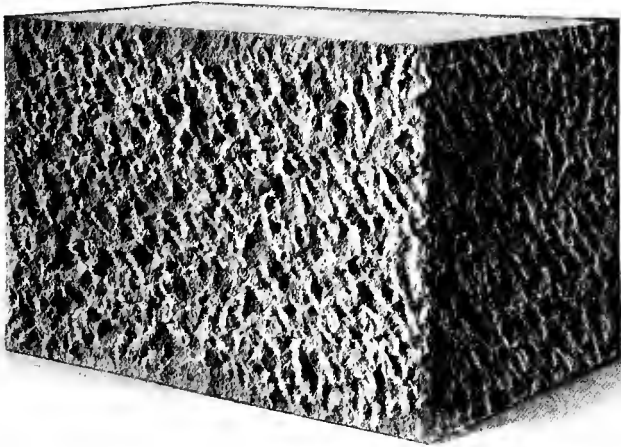

FIG. 27

projections of the stone by the use of the point. After the stone is worked over a few times it will present a rough sur-

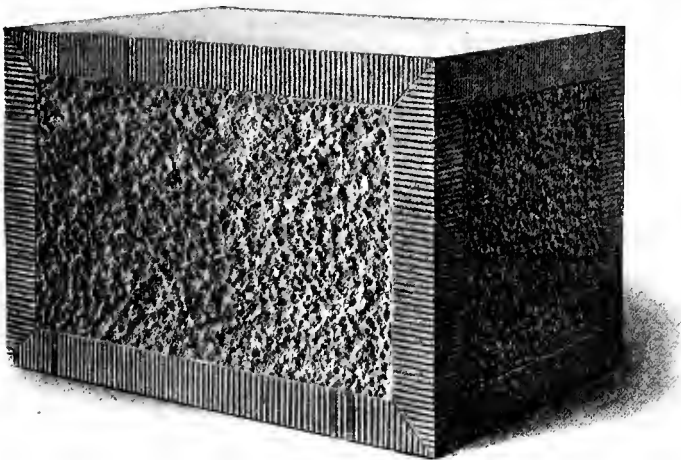

FIG. 28

face, as shown in this figure. This work is called **rough-pointed**. If, however, the work is gone over several times

more with the point, a finer effect is produced, such as shown in Fig. 28, which is known as **fine-pointed work**.

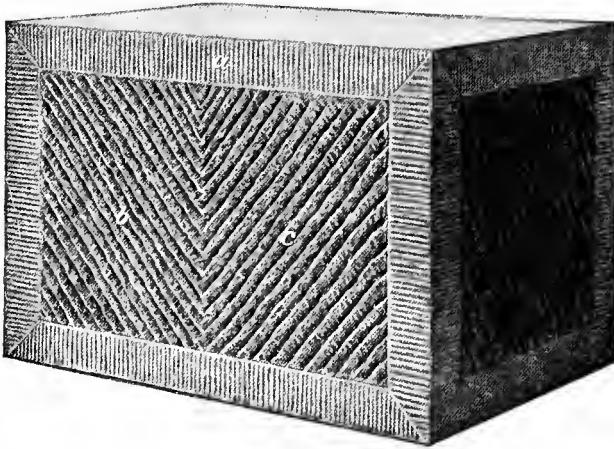

FIG. 29

**75. Margins.**—Building stones are sometimes faced an inch or more from their edges as shown in Fig. 28, and at *a*

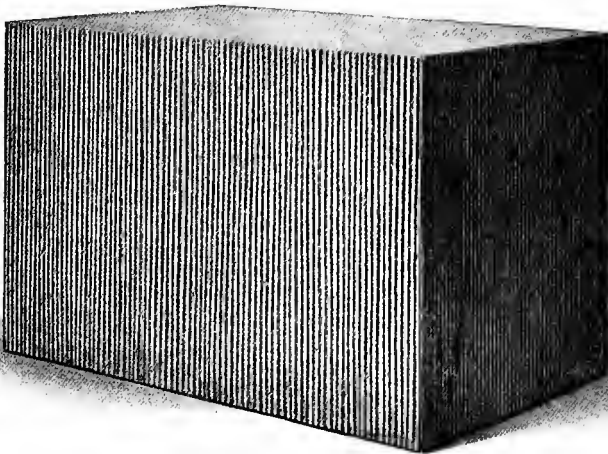

FIG. 30

in Fig. 29. This facing is known as a **margin**, or **draft**. On soft stone, this margin is cut with a chisel, but on very hard

stone, such as granite, it is cut usually with an ax, or peen hammer, in which case the surface would be plainer than the chiseled work and without the well-defined parallel channeling.

**76. Broached Work.**—Fig. 29 illustrates what is sometimes called broached work. In this kind of work the stone is dressed with a point, so as to leave continuous grooves over the surface. At *a* is shown the margin, and at *b* and *c* the broached center, which is cut in opposite directions in order to illustrate right- and left-hand broaching, respectively.

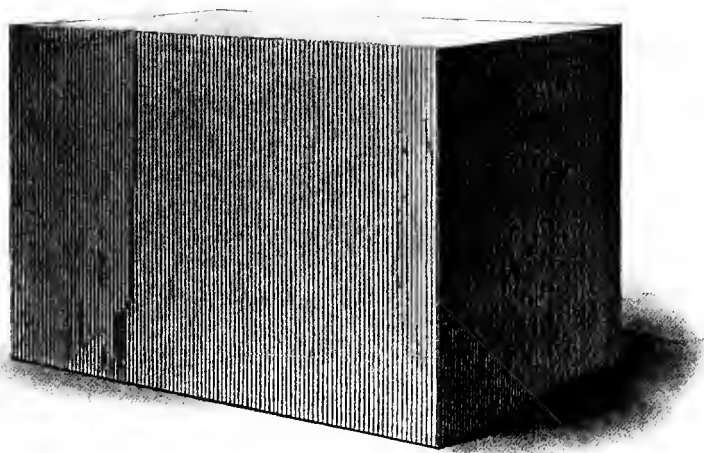

FIG. 31

**77. Tooled, or Drove, Work.**—Tooled, or drove, work is illustrated in Figs. 30 and 31. This class of work is generally done by machine and shows a regular and even appearance, as in Fig. 31. It may also be done by hand, in which case it has a somewhat more irregular and possibly more pleasing effect, as shown in Fig. 30. Drove work is described as six-cut, eight-cut, and ten-cut, according to the number of grooves to the inch.

**78. Rubbed Work.**—Sandstones and most of the limestones are often finished by rubbing their surfaces until they

are perfectly smooth. By continuing the rubbing long enough, granite and marble can be given beautiful polishes. Rubbed work is finished either by hand, using a piece of soft stone with water and sand, or by a machine which performs the same operation. If the rubbing is done soon after the stones are sawed into slabs and are still soft, it is cheaply and easily performed, as the sawing makes the face of the stone comparatively smooth. This kind of finish is shown in the plain surfaces around the carved panels in Figs. 39, 40, and 41.

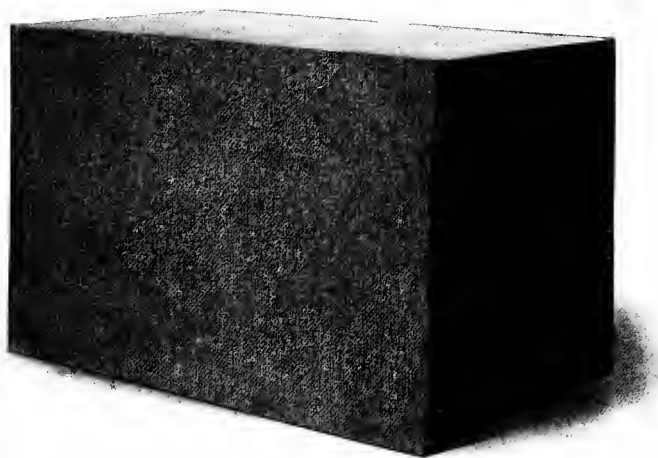

FIG. 32

**79. Bush-Hammered Work.**—A stone finished by a bush hammer or pneumatic bush chisel, which is generally used on granite and hard limestone, is shown in Fig. 32. The stone is first dressed to a fairly smooth surface and then finished with the bush hammer. The degree of fineness in the finish is determined by the thinness of blades in the hammer, the usual number being eight or ten to the inch.

**80. Vermiculated Work.**—In Fig. 33 is shown a stone having a somewhat elaborate finish, which is known as vermiculated, from its worm-eaten appearance. Stones so cut are used principally as quoins and in base courses. Owing to the



cost, this dressing is not often used in the United States, except for very expensive work.

**81. Rusticated Work.**—Two examples of rusticated work are illustrated in Figs. 34 and 35, the former showing



FIG. 33

the stones with sharp edges and the latter the stones with rounded edges. The joint should always be at the upper edge of the rustication as shown at *a* in each illustration, as it is better protected from the weather when in this position. If the joint were placed at the lower edge of the rustication,

rainwater would lie on the lower horizontal surface and be liable to work its way back into the joint. The projection above the joint throws a heavy shadow at this point and strongly emphasizes the courses. The use of rustication is further illustrated in Fig. 5.

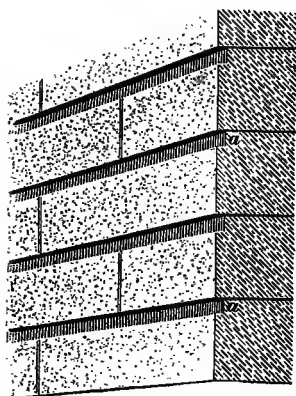

FIG. 34

Fig. 35, the depth should be equal to the height. The rustication is sometimes obtained by V joints, wherein the edges of the stone are chamfered or splayed. Rusticated masonry is sometimes laid with close vertical joints, as in Fig. 34, but is more frequently laid with the vertical, as well as the horizontal, joints rusticated, as in Fig. 35. The latter method gives the better effect when the stones are of good length.

Rusticated work is used in massive buildings, usually for the first story, forming a heavy base treatment strong in shadowed joints, on which is placed the lighter and more ornate upper stories, where the joints are close or, if rusticated, very much smaller than those below. The surface of rusticated stonework is usually dressed in such a way as to give a rough appearance; this may be done either in rough-pointed, fine-pointed, or vermiculated work, as shown in Figs. 27, 28, and 33, respectively. These surfaces form a

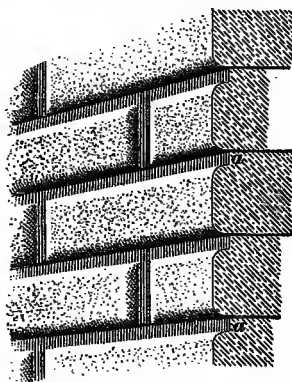

FIG. 35

pleasing contrast with the plainer surfaces of the stones above. Good examples of rusticated masonry are to be seen in the Italian palaces of the Renaissance period.

---

### CARVED WORK

**82.** The preparation or cutting of stone surfaces has been taken up, and thus far rough rock faces and dressed faces, such as fine- and rough-pointed, bush-hammered, vermiculated, etc., have been considered. The final step in the elaboration of stone is **carved work**. This requires more skill than common surface finishing, and in fact is an art requiring the skill of the sculptor. A close relation exists between stone dressing, as already described, and stone carving, to be described. The same tools are used, but, in general, less attention is paid in carving to securing an even surface than to the artistic effect of each line or surface.

**83.** The object of stone carving is to embellish the building, to bring out the color and the attractiveness of the stone, and to give the building individuality from the nature of the decoration. Carving, therefore, as distinct from stone dressing, is employed for individual stones or masses of stones.

**84.** Carving was originally applied to that ornament which was cut by hand. As machines now do the work, or assist in the work which was formerly done by hand, the former distinction will no longer apply. In general, therefore, the term carving is applied to the individual decoration by cutting of various stones.

**85.** Carving may be done on the solid block, on surfaces dressed by the methods described, or on moldings which have been cut by the machines mentioned. The carving may be done in the shop, on the site of the building, or on the façade after the exterior of the building is otherwise complete.

**86.** Work which can be carved in small pieces, so as to be readily handled and set without danger of breakage, is

usually done in the shop, where tools and material provide every facility in the way of cutting and handling.

**87.** Some stones are carved on the ground near the building when there is sufficient space and the nature of the building will permit the setting of the stone as the work progresses. This method of cutting overcomes the risk incident to transportation.

**88.** Elaborate carving on large blocks, such as groups of figures or statuary, sustains too great a risk of breakage to be done by either of the methods mentioned. In such cases, the rough block of stone, or the stone roughly dressed to the approximate shape of the finished ornamentation, is set in place, and the carving done from a scaffold after the danger of damage is past. This refers particularly to large carvings with considerable projection near the base of high buildings, where quantities of materials will be hoisted past them, or where materials are apt to fall on the finished work and damage it beyond repair.

**89.** The softer stones, such as the limestones and marbles, being more easily worked, are more generally used for carving, as the expense is much less than when the granites and hard sandstones are employed. Care must be taken also to employ for carving, stones having a uniform texture and hardness throughout, as well as those which will stand the weather well. Great quantities of Indiana limestone are used for carving in the United States.

**90.** The scale and the minuteness with which carving should be executed depends on its height from the point or points from which it will be seen. Work that will be close to the eye of the observer should be carved out in great detail and fineness if the texture of the stone will permit it, while work at some height from the eye to be effective should be bold and coarse in treatment. The latter point is often overlooked, and minute carving, beautiful in itself when viewed at close range, loses its effectiveness when placed at such a height that much of its detail is lost.

**91.** In general, the same tools already described for stone dressing are used for stone carving. For some stones the tools may be adapted to particular uses, and, especially for marble, smaller and finer-edged tools are required for more delicate carvings.

**92.** Carving is usually done from full-size drawings prepared in the architect's office, or from models prepared for the approval of the architect or owner of the building.

**93.** Instead of making templets of all the work, the stonemason often resorts to expedients which will shorten the labor

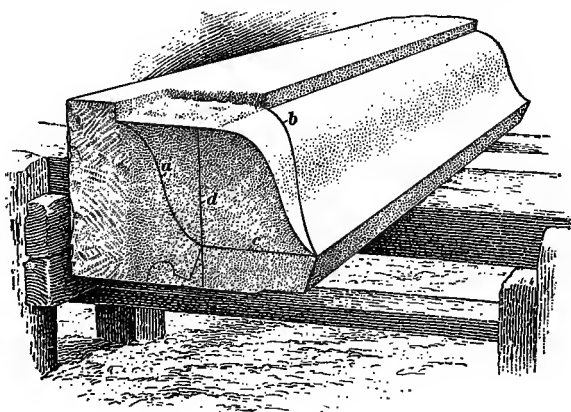

FIG. 36

of preparing the stone for cutting. When the detail is a simple one and the drawing has been made full size by the architect, the detail is sometimes drawn on the end or face of the stone. An instance of this character is shown in Fig. 36. The pencil lines *a*, *b*, and *c* may be seen where they have been drawn ready for the stonemason to cut the internal angle. The line *d* is used in laying out the profile of the molding *a*. A similar stone, cut to the lines marked, and ready to set in the building, is shown in Fig. 37.

**94.** Where the detail is a little more elaborate, the lines of the architect's full-size drawing are sometimes pricked through

the paper with a fine needle at close intervals. The drawing is then laid on the stone and fine charcoal or graphite is sprinkled over the drawing. Sufficient of the material sifts through the holes to locate the lines so that they can be drawn in pencil on the stone. Care in laying out the design is essential to a satisfactory carving.

**95.** Models in clay are frequently prepared, in order that the architect, the owner, and others may judge of the appearance of the finished work. Plaster casts are made from these models and are used by the stonemason in place of drawings. The plaster cast is used in preference to the model, as it is

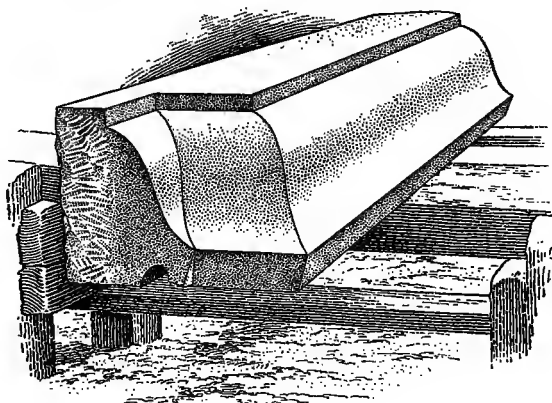

FIG. 37

lighter in weight, and if damaged can be replaced. The expert carver can successfully reproduce the plaster model in stone. Definite rules cannot be laid down for measuring or laying out this class of work, the eye of the carver being trusted usually to reproduce faithfully the lines of the model from which he works.

**96.** The ornament is roughly blocked out by means of the point (*a*), Fig. 23, followed by chisels or other tools that will bring the work to the proper outline with the least number of cuts. A variety of surface and background textures are possible by the use of the various tools already mentioned.

**97.** A large portion of the cornice of a building is sometimes made in one piece, as in Fig. 38, which shows a workman cutting or carving by hand the sides of the dentils in the course *a*, which cannot be made on the planer. The finishing of this course is all the handwork required on this cornice.

**98.** When carved work is set in the building before the completion of the building, it should be boxed or covered with boards to protect it from any possible damage.

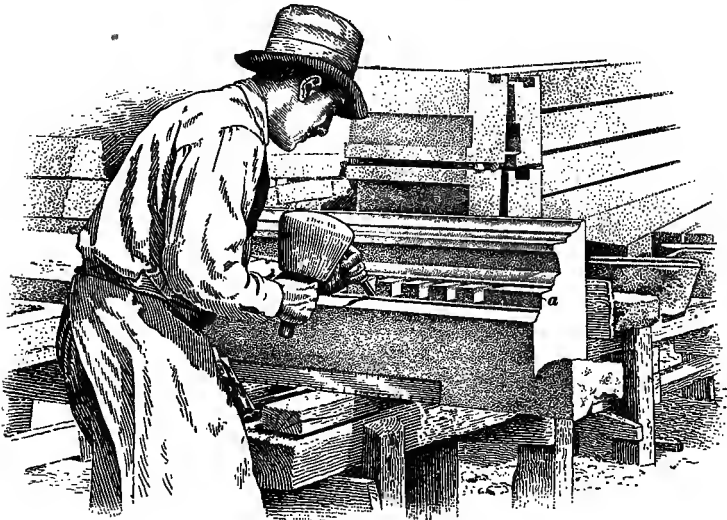

FIG. 38

**99.** Besides figure work, carved ornament is utilized for the decoration of plain or molded band-courses, capitals and bases of columns, pilasters, balustrades, friezes, panels, etc. Conventional or naturalistic plant and animal forms, as well as geometrical forms, are used as motifs for these ornaments. Figs. 39, 40, and 41 illustrate specimens of work executed on the City Hall of Philadelphia, Pennsylvania.

**100.** In Fig. 39 is shown an example of naturalistic carving in *alto-* or high-relief, and in *bas-*, or low-relief. The forms used are plant and bird life. The two plants represented are



FIG. 39







FIG. 41



FIG. 42



FIG. 43



FIG. 44

the *Nuphar advena*, or water lily, and the *Typha latifolia*, or common cattail. Both of these motifs are copied closely from nature, and the detail is minutely carved, as the work is placed only a slight distance above the eye. The carving near the bottom of the panel is in alto-relief and that in the upper portion is in bas-relief. The stone here used is marble, and the broad expanse of plain surfaces about the carving sets it off and frames it well. Coarse-grained stone, owing to its rough texture and the size of the particles, would not be suitable for such delicate carving.

**101.** In Fig. 40 is illustrated a similar panel in which the natural forms copied are the foliage and fruit of the oak and the mistletoe, with squirrels perched on the limbs. This is a most beautiful piece of work and is very realistic. The distribution of the different treatments of relief is the same as in the previous example.

**102.** In Fig. 41 is shown a conventional scroll design that fills the entire panel in alto-relief and consists of a highly conventionalized acanthus, carved with great spirit.

**103.** In Figs. 42 and 43 are illustrated two of the clustered columns in the Cincinnati Chamber of Commerce, designed by the late H. H. Richardson. The capitals of these columns are Romanesque, and are beautiful in design and execution. As will be observed, the carving is not very deep; this is due to the fact that the stone, which is granite, is exceedingly hard.

**104.** The entrance to the Cable Building, New York City, designed by McKim, Meade, and White, shown in Fig. 44, is an example of stonework where sculpture, the sister art to stone carving, is used in connection with the conventionalized plant motifs, geometrical motifs, etc. already described and illustrated. The two draped figures in this example are quite close to the eye, and are therefore carved with considerable exactness and detail. It is probable that these figures were carved from scaffolds at the building, after plaster models of the figures had been previously approved by the architects.



# PLASTERING

---

## INTRODUCTION

**1. Plastering** is the process of applying a plastic material known as *plaster* to the surfaces of walls and ceilings so as to produce a neat, smooth, and satisfactory finish. This process is applicable to both the exterior and the interior of the structure. Plaster applied on the exterior of the building is called *stucco*. When applied on the interior of the building it is called *plastering* or *interior plastering*.

**Plain plastering** consists of covering surfaces with a plain coating of plaster of a uniform finish.

**Ornamental plastering** is the art of forming plaster ornament in relief upon plain surfaces. This relief is in the form of moldings, ornaments, pilasters, cornices, panels, and other architectural or decorative features which add beauty and dignity to the interior walls and ceilings.

---

## PREPARATION OF THE BASE

---

### SURFACES TO BE PLASTERED

**2. Plaster** is merely a coating and must be properly supported. It is, therefore, necessary that a suitable foundation, or *base*, be provided to which the plaster can be applied. Such a base exists in the rough surfaces of brick, stone, terra cotta, and other masonry walls. As a rule, however, a base is formed on these walls by means of furring and lathing, to which plaster is applied. In wooden buildings, the base consists of lathing that is applied directly to the frame work of the building.

**3. Masonry Walls.**—Walls of common brick offer a good surface to which plaster will adhere, especially when the bricks have rough surfaces, and the joints in the brickwork are not entirely filled with mortar. Hollow brick, hollow tile, and gypsum blocks are usually grooved so as to provide a good grip, or base, for the plaster. The surface of stone is not as good as that of brick, but if the stone is rough and the joints are more or less open the plaster will hold to the stonework in a satisfactory manner.

Plaster is generally applied directly to the outside of masonry walls. It is, however, rarely applied to the inside, since water is apt to work its way through a solid wall, and injure the interior plaster.

**4. Condensation.**—Another objection to plastering directly on the inner surface of a solid masonry wall is that in cold weather the wall becomes cold throughout, including the interior plaster work. When the warm air of the room comes in contact with the cold plaster surface, the moisture in the air is condensed on this surface. This moisture may prove to be very injurious to wall paper, painting, or other decorations that may have been applied to the plaster.

---

## FURRING

**5.** Methods have been devised to keep condensed moisture from forming on walls, by constructing the walls with hollow spaces in their thickness, or using hollow terra-cotta tiles or hollow bricks. These devices, however, cannot always be depended upon. Consequently, it has become a general practice to fasten wooden or metal strips, known as *furring*, to the inside of masonry walls, to form an air space between the wall and the inside plastering. Furring serves three purposes. It prevents water from working its way through the inside plaster; it prevents condensation of moisture on the inner surfaces of the plaster; and it provides a space back of the lath in which the plaster can form a key.



**6. Wooden Furring Strips.**—Wooden furring strips, or furring, are shown at *a* in Fig. 1. These strips are usually 1 inch thick by 2 inches wide and are nailed to the wall

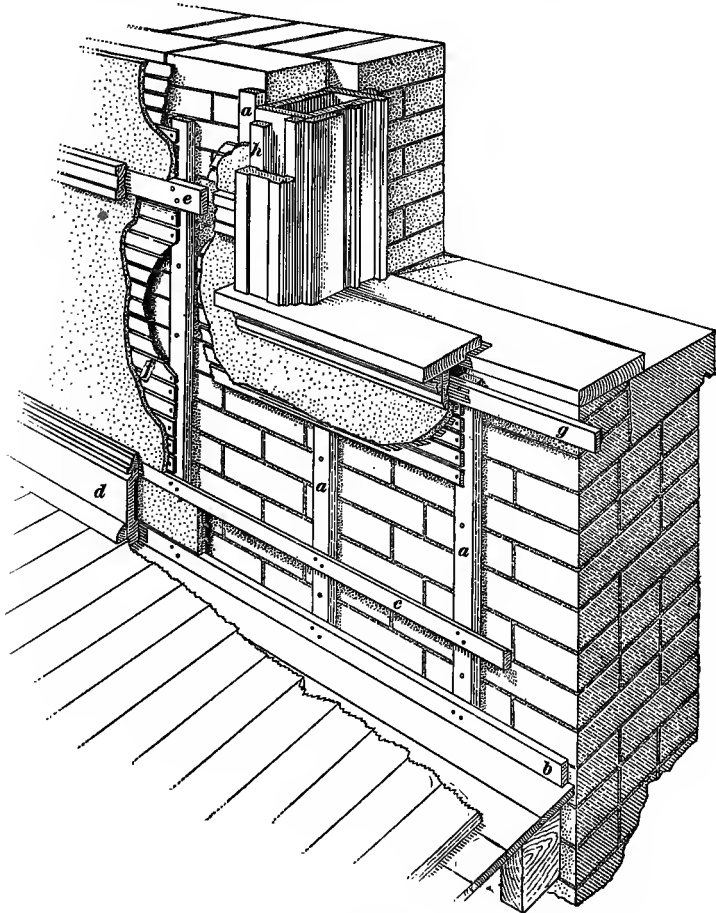

FIG. 1

vertically by a carpenter. These strips are placed either 12-inches or 16-inches on centers.

**7. Metal Furring.**—Metal furring consists of strips of metal which are attached to the surface of the wall, and to

which lath is applied. Metal furring may be of various standard structural forms, such as small-sized channels,

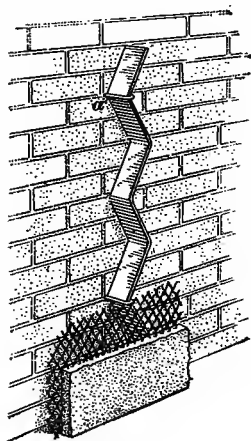

FIG. 2

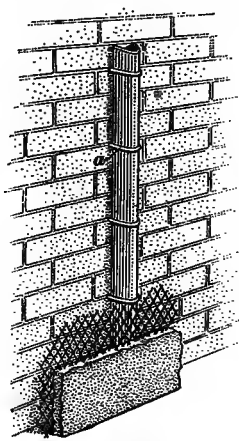

FIG. 3

angles, I beams, or T's, or it may be of forms especially designed for the purpose. In Fig. 2 is shown a simple form of metal furring made by bending a flat strip of metal, which is attached to the wall by means of staples *a*. In Fig. 3 is shown a strip bent into a U-shape, secured to the wall by means of the staples *a*.

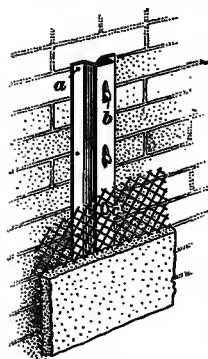

FIG. 4

In Fig. 4 is shown a sheet-steel furring strip which is nailed to the wall through the holes *a* on the sides. The furring holds the metal lath by means of the prongs *b*, which are bent over the lath to hold it in place, as at *c*.

**8. Combined Furring and Lathing.**—Metal lath, Fig. 5, with raised V-shaped portions, or ribs, is frequently used as the base for plaster on masonry walls. These ribs act as furring, and the separate furring strips are omitted because the sheet part of the lath is separated from the wall sufficiently to form an

air space after the plaster has been applied to the lath. The use of this form of lath and furring is seen in Fig. 6, the fur-

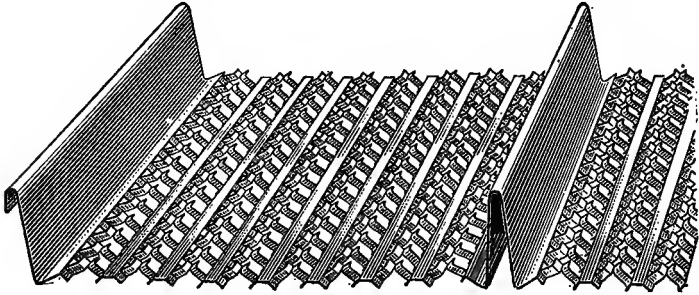

FIG. 5

rings or ribs *a*, being stapled to the brick walls, while the lath surface *b*, is held away from the wall. This form of lath may be applied directly to the exterior sheathing of frame buildings

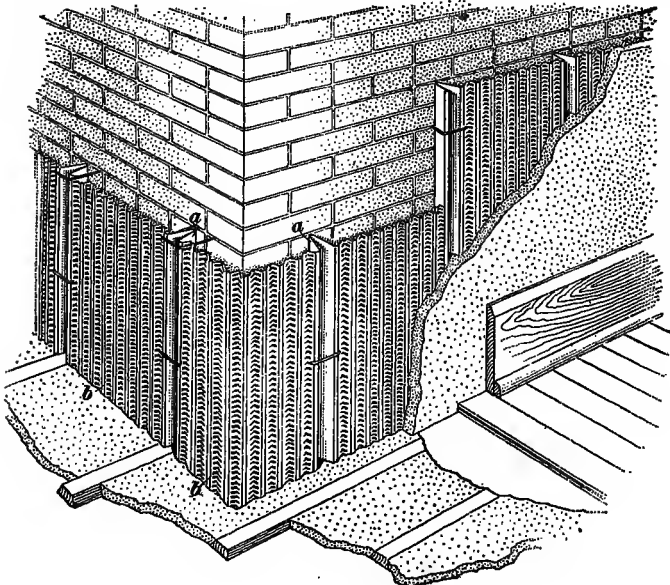

FIG. 6

for the purpose of receiving stucco. This lathing is used also as a support for solid plaster partitions as will be described later.

9. **Cross-Furring.**—Wooden furring strips *a*, Fig. 7, are sometimes nailed to the under sides of floor joists *b*, in order to make the ceiling level. This process is called *cross-furring*. The under surfaces of the floor joists are not always in the same plane, some being higher than others.

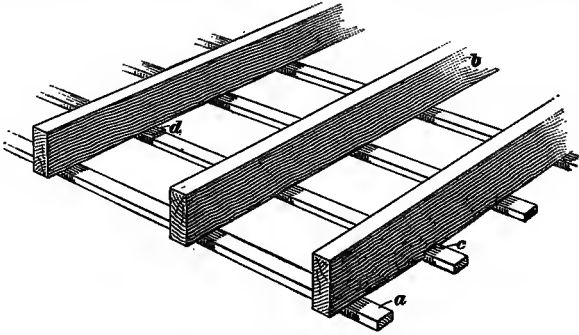

FIG. 7

When this occurs the furring is notched as at *c* when the joists are low, and is wedged down as at *d*, when the bottoms of the floor joists are high. The under surface of the cross-furring is thus made level and ready to receive the lathing and the plastering.

### GROUNDINGS

10. *Grounds* are strips of wood which are applied to walls as guides in plastering and to furnish nailing for the interior trim. Grounds are illustrated in Fig. 1 at *b*, *c*, *e*, *g*, and *h*; also in Fig. 8 at *a*, *b*, *c*, *d*, *e*, and *f*. These grounds must be secured to the wall so that the finished plaster surface will be even with the surfaces of the grounds, and the finished surfaces of the plaster will be even, plumb, and true.

When plaster is applied directly to masonry walls, grounds are applied directly to the masonry. The interior surfaces of such walls are generally uneven and to take up this unevenness the plaster must be made thicker in some places than in others. Grounds applied to such walls must also be varied in thickness. In some places they must be made  $\frac{1}{2}$  inch and in

other places an inch or more thick. These thicknesses must be adjusted so that the finished surfaces of the grounds on a wall will be in the same plane and the plaster surface will be even, plumb and true.

As a rule, masonry walls are furred and the grounds are applied on top of the furring as illustrated in Fig. 1. In such cases the thickness of the grounds is determined by the required thickness of the plaster coat, or, more exactly, the distance between the face of the furring and the face of the plaster.

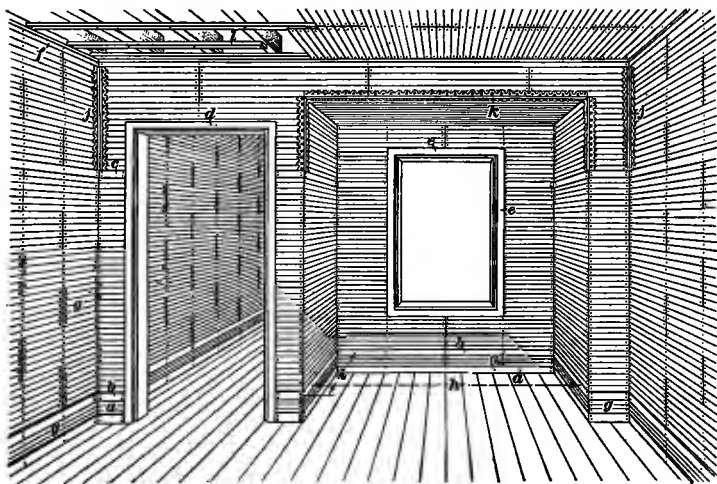

FIG. 8

This, in turn, depends upon the kind of lath used, the kind of plaster applied and the number of layers or coatings of plaster.

**11. Thickness of Grounds.**—The thickness of the plaster depends upon the nature of the base which supports the plaster or the surface to which the plaster is applied. Thus, for three coats of plaster, which are commonly used, the grounds should be of the following thicknesses: On gypsum block  $\frac{1}{2}$  inch; on brick walls  $\frac{1}{2}$  inch to  $\frac{3}{4}$  inch; on clay tile  $\frac{1}{2}$  to  $\frac{3}{4}$  inch; on wood or metal lath  $\frac{3}{4}$  inch; and on plaster board  $\frac{3}{4}$  to  $\frac{7}{8}$  inch.

When grounds are used in frame buildings, they are applied directly to the studding and are made from  $\frac{5}{8}$  to  $\frac{7}{8}$  inch thick.

**12. Application of Grounds.**—In Fig. 1 is shown a method of applying grounds to a furred wall. In Figs. 9 and 10 grounds are shown applied to stud walls or partitions. It will be seen that the grounds define the limits of the plaster as regards its thickness. At the same time, the grounds are placed so as to afford nailing for the trim.

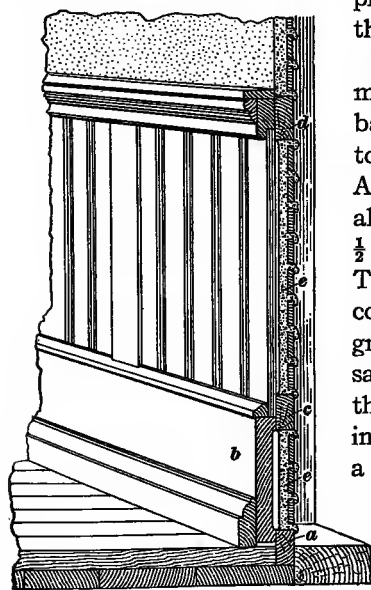

FIG. 9

In Fig. 1 is shown an arrangement of grounds to support a base board. A ground *b* is nailed to the furring *a* at the floor line. A second ground *c* is placed parallel to this strip so as to be about  $\frac{1}{2}$  inch below the top of the base *d*. The mold on the base will then cover the joint between the ground *c* and plaster. At the same time, the base board and the top molding can be nailed into this ground. A ground for a chair rail is shown at *e* and is made narrower than the chair rail so that the chair rail will cover the joints between the plaster and the ground.

Grounds applied to hold a wainscot in place are shown at *a*, *c*, and *d* in Fig. 9. The grounds *a* and *c* provide nailing for the base *b*, the ground *c* holding the lower ends of the matched boarding, and the ground *d* holding the upper ends of the boarding as well as the cap of the wainscot.

At *a* in Fig. 10 is a ground for a picture molding and at *b* are grounds that support a wooden cornice. The plastering inside such a cornice need not have the finished coat as it will not be seen.

On stud walls, the lath and one or two coats of plaster should always be carried down to the floor, back of bases, and wainscots, and behind wooden cornices. This, as illustrated in Fig. 9 at *e*, forms a protection against fire and vermin and prevents contact of the wood with the plaster. In Fig. 8 at *g*, lath is shown back of a wainscot and base.

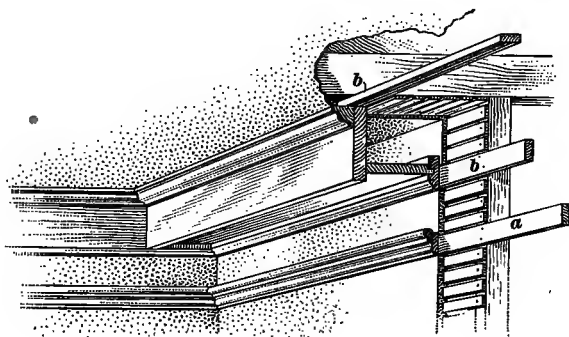

FIG. 10

**13. Measuring to Grounds.**—When wainscots, paneling, mantels, or other finished woodwork is to be installed in a room, measurements from which to execute such work can be taken as soon as the grounds are in place. The measurements between grounds will be the same as between plaster surfaces. Thus, in Fig. 8, measurements for paneling or wainscoting in the bay, such as at *h* or *i*, can be taken from the grounds. The wainscoting can then be manufactured or *gotten out* while the plastering is being applied.

#### CORNER BEADS

**14. Metal Corner Beads.**—When plastered corners are not chamfered or rounded, the angles of plastered walls and piers should be protected by metal *corner beads*, as shown in Figs. 11 to 17 inclusive. These beads furnish grounds for the plaster to finish against, as at *j* and *k* in Fig. 8, and form corners that will not be easily injured.

One form of metal corner bead, applied to a wood lath base, is shown at *a* in Fig. 11. The sides *b* of the bead are

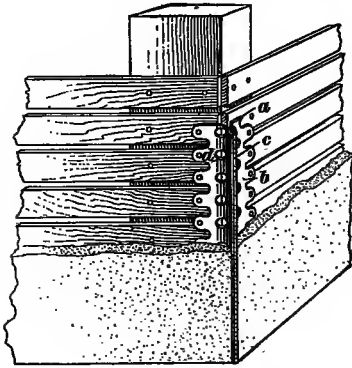

FIG. 11



FIG. 12

bent to fit over the corner, and are punched with holes to receive nails by which the bead is attached to its support. The edge *c* of the bead is formed into a shape that will be rigid and will retain a straight edge during the process of plastering, thus forming a true, straight corner. Openings *d* in the sides of the bead permit the plaster to form a key, which prevents the plaster from breaking away from the metal. Another type is shown in Fig. 12, in which the wings are expanded to a form that is securely held by the plaster.

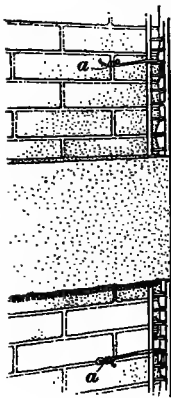

FIG. 13

In Fig. 13 is shown a bead attached to a brick corner, when the plaster is applied directly to the brick. The bead is held in place by wires secured to nails *a* driven firmly into the joints of the brickwork.

The bead shown in Fig. 14 is attached by wires *a* to a construction of metal furring and lath. The holes *b* may be used for nailing when this style of bead is used on a corner of wooden construction.

**15. Bull-Nose Corner Beads.**—For exposed corners in public buildings, hospitals, and other places subject to hard



knocks, a *bull-nose corner bead*, Fig. 15, is often used. By presenting a rounded metal corner, a bead of this style prevents injury to plaster from shocks or blows which might damage the ordinary metal bead.

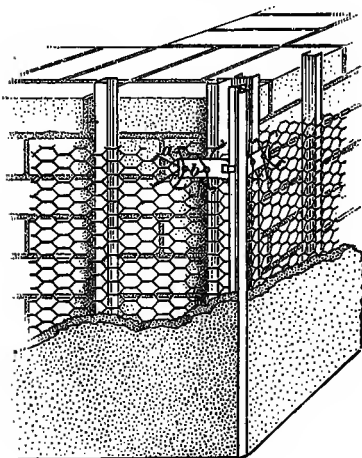

FIG. 14

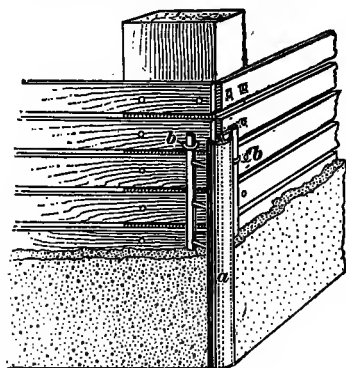

FIG. 15

The nose *a* is usually about  $\frac{7}{8}$  inch wide and is curved to a radius of about  $\frac{9}{16}$  inch. Bull-nose beads are made in a number of styles which are attached to a wood base by means of staples *b*, or by wires to metal lath.

Metal corner beads for inside angles, as in Figs. 16 and 17, are designed to form a ground against which the plaster may finish, and also to prevent cracks which sometimes occur at inside angles between walls, or between walls and ceilings. Holes *a* in the sides of the bead shown in Fig. 16 permit nailing to wood construction, or wiring to metal lath. The mesh of the sides of the bead shown in Fig. 17 permits fastening by means of wire. Frequently, however, 12-inch strips of metal lath are used in interior angles for reinforcement, as at *a* in Fig. 18, in which case inside beads are not needed. This

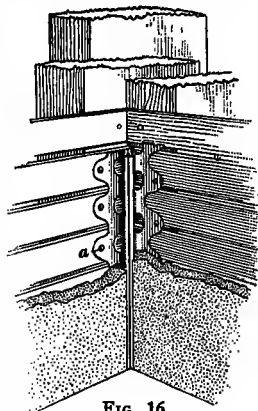

FIG. 16

treatment resists the tendency to crack which occurs at these corners.

Most of the styles of metal corner beads are made in 5-, 6-, 7-, 8-, 9-, and 10-foot lengths. The beads should be set carefully to plumb and straight lines, corresponding to the grounds, and be secured to the supports before the plaster is applied. They should extend in one piece for the whole length of the corner, unless the height is greater than the length in which the bead is made.

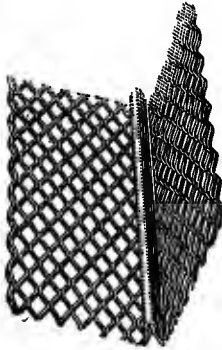

FIG. 17

**16. Metal Base Screeds.**—*Metal base screeds*, shown in Figs. 19 and 20, are sheet metal shapes used in place of wood grounds, at such places as between cement bases and plastered walls. They make neat joints at the union of the two materials, and assist in bringing each surface to true lines and levels. When the thickness of the cement base is greater than the thickness of the plaster, the cement is brought to the line of the edge *a* in Fig. 19, while

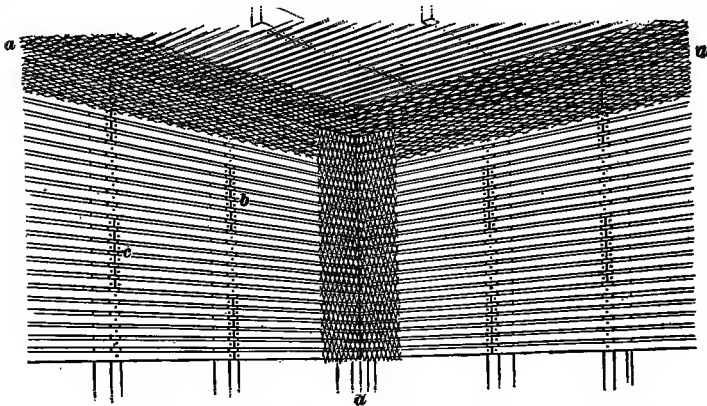

FIG. 18

the plaster is brought to the line *b*. Metal base screeds of the style shown in Fig. 20 are used when the cement base is the

same thickness as the plastering, both surfaces being brought out to the edge of the bead. Metal base screeds of the styles

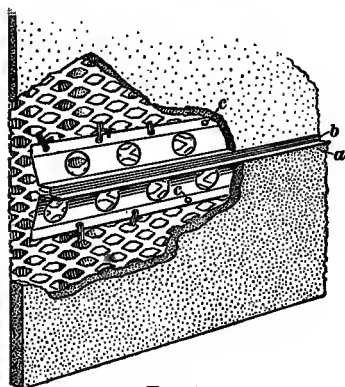

FIG. 19

shown in Fig. 19 are attached to wood by means of nails through the holes *c*. On metal lath, wires through these holes will hold the screed

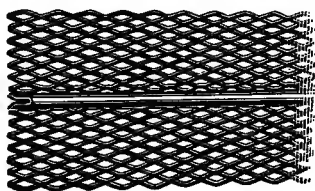

FIG. 20

in place, as shown in the figure. In the style shown in Fig. 20, the screed may be attached through the mesh of the sides.

---

## LATH

17. *Lath*, or *Lathing*, is a base which is fastened to walls or ceilings, and is designed to provide a grip, or bond, to which the plaster will hold firmly. Lathing is made of wood strips or of metal in various forms.

---

### WOODEN LATH

18. **Common Lath.**—Common wooden lath is made of white pine, fir, spruce, red cedar, hemlock, and yellow pine. The wood is sawed into strips  $1\frac{1}{2}$  in.  $\times$   $\frac{1}{4}$  in.  $\times$  32 in. or 48 in. The 32-inch length is designed for application to furring strips, joists, and studs that are set to the standard spacing of 16 inches on centers. The 48-inch lath, which is the more commonly used, may be used with 12-inch spacing, as well as with 16-inch spacing. Lath 1 inch wide and  $\frac{1}{2}$  inch thick are recommended by some manufacturers as a base for stucco,

Lath  $\frac{3}{8}$  inch thick may be obtained in some localities, and these can be used either for plaster or stucco.

All lath should be straight-grained to prevent their warping, due to the absorption of moisture from the plaster. They should be free from rot or decay to insure durability, clear of shakes, large or loose knots that will reduce their strength, and free from bark and resin pockets which may cause subsequent discoloration of the plaster.

Lath which are half-green, or only partially seasoned, are considered best for gypsum and cement plasters. Those used with lime plaster should preferably be well seasoned.

Common lath are sold by the thousand, one thousand lath 48 inches long being estimated to cover from 60 to 75 square yards of surface, depending upon the width of the spaces between the lath, and the number and size of the openings in the walls.

**19. Application.**—Common lath are nailed to the supports in parallel rows, as shown in Fig. 8, spaces being left between the sides and ends of the lath through which the plaster may be pressed to form a key which will hold the plaster firmly in place. When lime plaster is used, the lath applied to the ceiling joists should be spaced  $\frac{3}{8}$  inch apart, and on the side walls, the lath should be spaced  $\frac{1}{4}$  inch apart. For gypsum plaster, many of the manufacturers recommend spacing the lath not over  $\frac{3}{8}$  inch apart, especially on ceilings, while some suggest that the lath should not be over  $\frac{3}{16}$  inch apart on side walls. Some magnesite stuccos hold best when the lath are spaced only  $\frac{1}{8}$  inch apart. Care must be taken to space the lath evenly.

The ends of the lath should not lap over one another, but should be placed end to end and about  $\frac{1}{4}$  inch apart. Continuous joints between the ends of the lath should not occur on one support, but the lathed surface should be divided into panels about 15 to 18 inches in height, as shown at *b* in Fig. 18. The vertical joints of these panels should break on alternate supports, as at *b* and *c*, or else continuous cracks in the plaster will be liable to form in front of these joints. Lath are

usually attached to joists and studs with cut or wire nails about  $1\frac{1}{8}$  inches long, which have large flat heads, and one nail is used at each support.

**20. Lath on Wide Surfaces.**—Where joists, studs, or girders are over 2 inches in width, strips of lath, as shown at *a* in Fig. 21, should be attached to the surfaces to allow space for the plaster to form a key. Cross-furring may be applied to

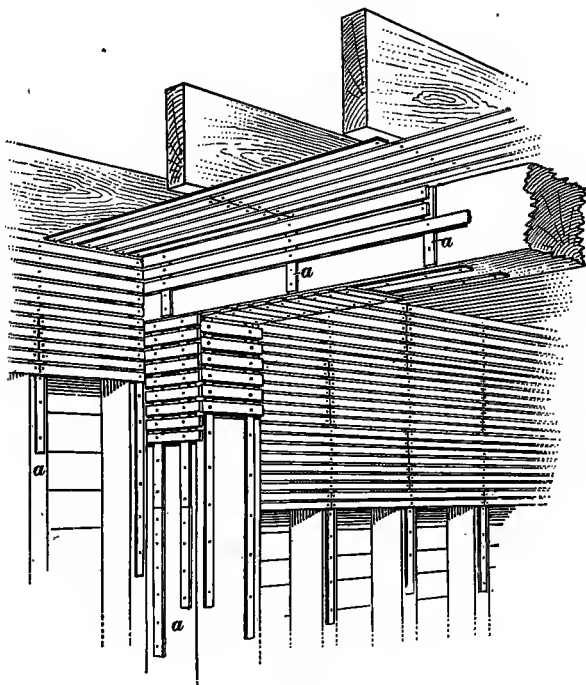

FIG. 21

thick joists, as at *l* in Fig. 8. Nails are sometimes studded thickly over wide surfaces of wood, such as beams, in order that the plaster may form a clinch around the heads of the nails. This is done instead of stripping.

**21. Lathing for Back-Plastering.**—The outside walls of frame houses are sometimes *back plastered* to help keep out the cold. *Back-plastering* consists of installing a lath base

between the studs, and coating this base with plaster. This form of construction is shown in Fig. 22. The vertical furring strips *a* are attached to the studding *b*, and the lath *c* are attached to these strips. The lath are separated from the outside boarding, or sheathing *d*, by means of these strips *a*, and a suitable space is provided in which the plaster may form a key, as shown at *e*. The air space between the sheathing *d* and the back-plastering acts as insulation to prevent the passage of heat and cold.

**22. Sheathing Lath.**—A combined sheathing and lath, known as *Byrkit lath*, is shown at *f* in Fig. 22. This lath

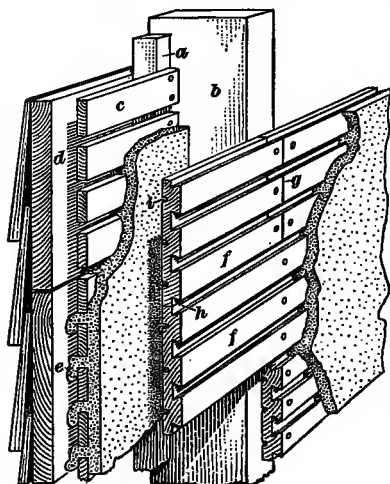

FIG. 22

consists of boards  $\frac{3}{4}$  inch in thickness, containing grooves *h*, and is made in widths of  $3\frac{1}{2}$  and  $5\frac{1}{2}$  inches. The lath is made in lengths of 4 feet and upwards. Plaster is bonded to Byrkit lath by filling the dovetail-shaped grooves *h*. The back of the lath is also grooved, as shown at *i*, to prevent the lath from warping and splitting. The end joints of this lath are made on the support, as at *g*.

The use of this form of lath adds great stiffness to the frame of the building, especially when long lengths are used. Sheathing may be omitted when this lath is used. Thin partitions may be made by using this lath on both sides of 2-inch studs. The lath is also useful for plastering sliding-door partitions, since no lining of the pockets is required. Nails can be driven anywhere in the lath without loosening the plaster.

**23. Assembled Wooden Lath.**—A form of lath known as *Bishopric Board* is shown in Fig. 23. This lath consists

of a waterproof fiber board *a* covered on one side with a waterproof coating *b* known as *asphalt mastic*. Creosoted wooden lath having beveled edges, as shown at *c*, are applied and the whole subjected to pressure, which causes the lath to adhere firmly to the board *a*. The asphalt coating makes the board both water- and air-tight. The dovetail spaces between the laths provide excellent keys for the plaster.

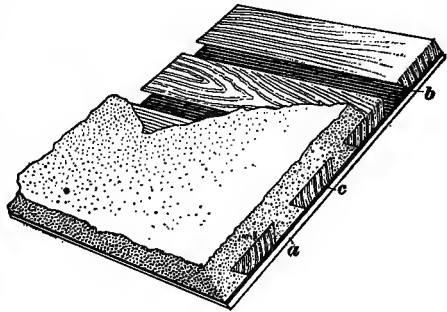

FIG. 23

Bishopric board is shipped in rolls, each roll containing one sheet 4 feet wide and 25 feet long.

### METAL LATH

**24. Forms of Metal Lath.**—Steel and iron sheets and wire are worked into forms that may be used as bases for plastering. When made from sheets, the product is known either as *expanded-metal-lath*, as shown in Fig. 24, or as *sheet-metal lath*, as shown in Fig. 25. When made of wire, the product is called *wire lath*, or *metal fabric*, and is shown in Fig. 26.

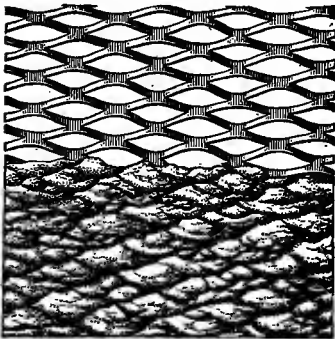
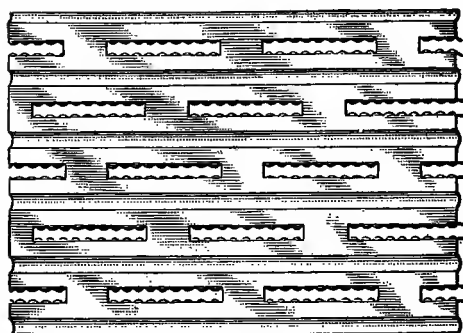
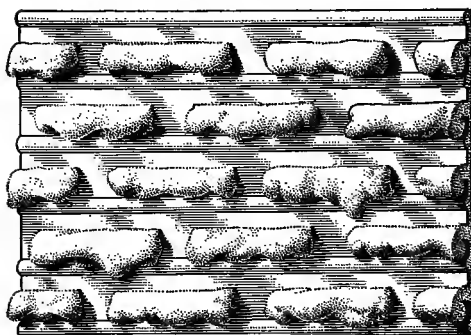

FIG. 24

**25.** In Fig. 24 is shown the back of a panel of expanded-metal lath, showing the key after plaster has been applied to the lath. In Fig. 26 is shown a panel of wire lath similarly treated. In Fig. 25 (*a*) is shown a panel of sheet-metal lath, and in (*b*) the reverse side of the same lath after plaster has been applied to it.



(a)



(b)

FIG. 25

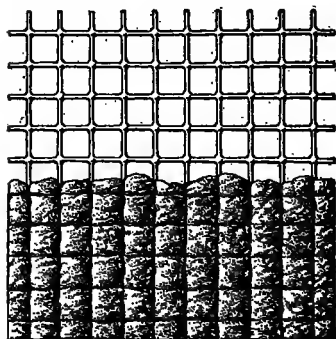

FIG. 26

**26. Protecting Metal Lath.**—Steel is subject to corrosion on exposure to moisture. No metal lath, manufactured from steel, is now sold unless protected by a preservative paint covering, or by being galvanized. When steel is fully embedded in plaster there is little danger of corrosion except in positions where the plaster itself is not suitable, as in damp situations. In such positions Portland cement plaster should be used, and it should fully embed the lath. Metal lath is also made of rust-resisting

metal such as pure iron or copper-bearing steel.

#### EXPANDED-METAL LATH

**27. Expanded-metal lath** derives its name from the process of manufacture. Sheets of metal are first slit and then expanded so that a mesh is formed, through which the plaster may pass and form a key. Expanded metal is made in



sheets from 16 to 24 inches in width, and usually 96 inches in length.

28. Plain expanded-metal lath is shown in Fig. 27. As in (a) it is called the *diamond mesh*; in (b), the *oblong mesh*;

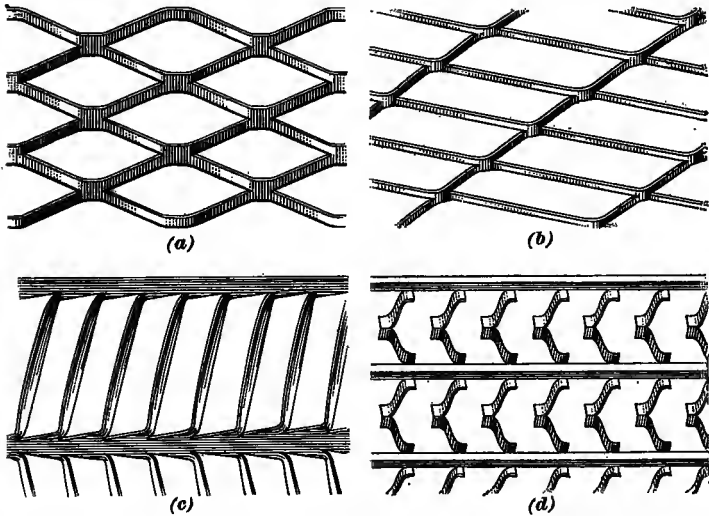

FIG. 27

in (c), the *herringbone lath*, and in (d), the *hy-rib lath*. There are many styles of expanded-metal lath, made in several

**TABLE I**  
**MINIMUM WEIGHTS OF METAL LATH PER SQUARE YARD**

Interior Work			
Expanded metal	Walls and partitions	Studs 12 in. on centers	2.20 lb.
Expanded metal	Walls and partitions	Studs 16 in. on centers	2.50 lb.
Expanded metal	Ceilings	Joists 16 in. on centers	3.00 lb.
Exterior Work			
Expanded metal	Any position	Supports 16 in. on centers	3.40 lb.
$\frac{3}{8}$ in. rib lath	Any position	Supports 24 in. on centers	3.00 lb.
$\frac{3}{8}$ in. rib lath	Any position	Supports 30 in. on centers	3.50 lb.
$\frac{3}{8}$ in. rib lath	Any position	Supports 36 in. on centers	4.00 lb.

weights of metal. Table I gives the weights adopted as standard by the Associated Metal Lath Manufacturers.

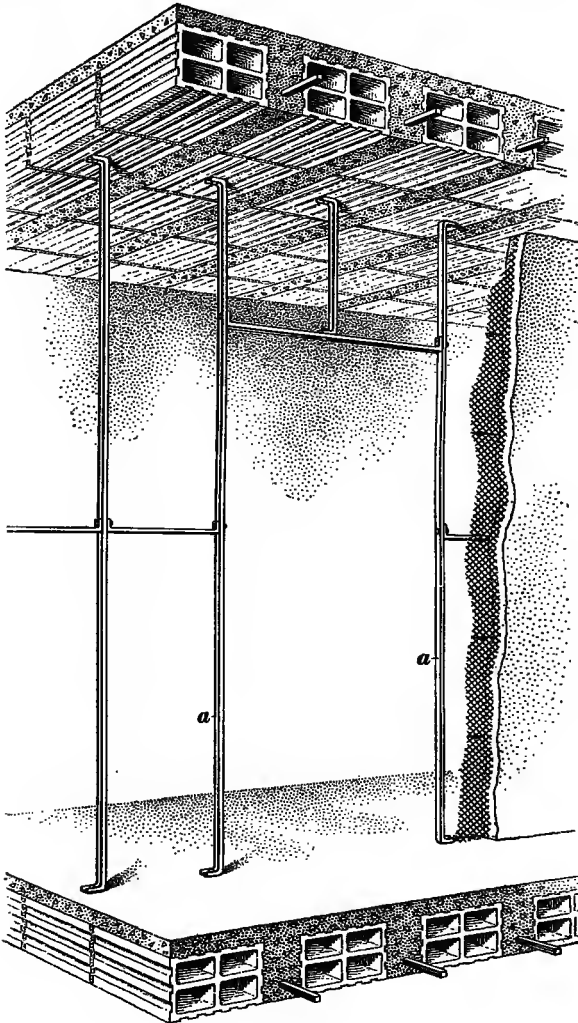

FIG. 28

**29. Application of Plain Expanded-Metal Lath.** Studding for the support of plain expanded-metal lath may

be of wood, of rolled structural shapes, such as channels or angles, as shown at *a* in Fig. 28, or of sheet-metal shapes, as at *a* and *b* in Fig. 29. The lath is attached to wood supports by  $1\frac{1}{4}$  inch galvanized staples which are driven through the meshes of the lath at about 6-inch intervals at every support.

When applied to metal supports, the lath is wired to the supports or fastened with clips. Three styles of clips are shown in Figs. 30, 31, and 32. The prongs *a* in Figs. 30 and 31 are intended to fit over the flange of an I beam, while the prongs *b* extend through the lath and are bent so as to hold the lath securely. The prongs *a* and *b* in Fig. 32 may all extend through the lath and be bent around the support, or two of the prongs, as the prongs *a* may be used to go around the support, while the other two may be bent back to go through the lath and hold it in place.

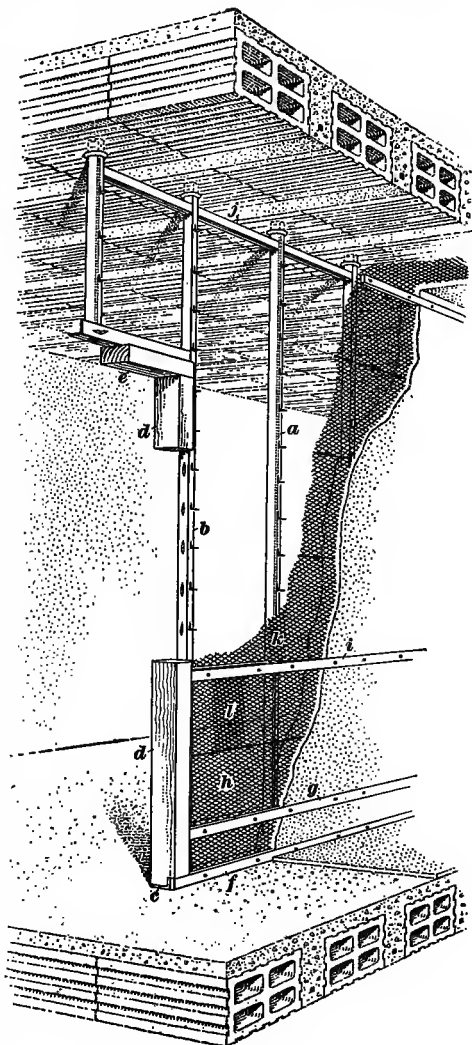

FIG. 29

The sheets of lath are placed horizontally on the studding, the horizontal edges being lapped 1 inch or less. The edges are tied together with wire

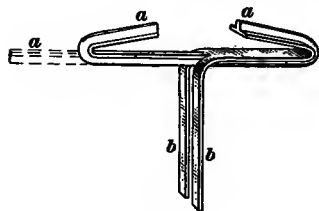

FIG. 30

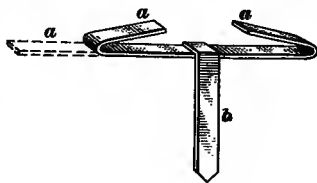

FIG. 31

and the lath is fastened to every stud. Where the ends of the sheets meet over a stud, as at *k* in Fig. 29, they are lapped about 2 inches and wired together and to the studs. Where the ends meet between the studs, as at *l*, they are lapped 8 inches and wired together.



FIG. 32

#### SHEET-METAL LATH

**30.** Metal lath, made of steel sheets which are punched out, or expanded in some parts in order to form a good key for the plaster, is classed as *sheet-metal lath*. The lath is made in plain flat sheets for ordinary lathing.

**31. Forms of Sheet-Metal Lath.**—A form of plain perforated sheet-metal lath is shown in Fig. 33. This lath, known as the *Sykes lath*, has ridges *a* about 2 inches apart. Portions *b* are punched out to form openings and loops *c*. Another form of sheet-metal lath is shown in Fig. 25. The *Bostwick*, or *Truss-Loop* lath has truss-like loops.

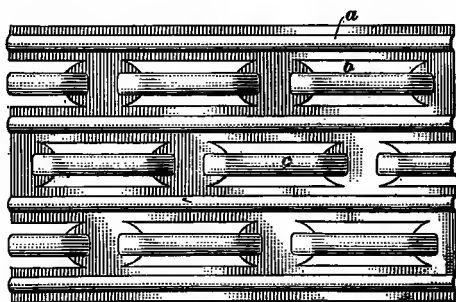

FIG. 33

**32. Characteristics of Sheet-Metal Lath.**—Sheet-metal lath is very rigid, and forms a stiff base on which to apply plaster. The openings in the sheet being smaller in proportion to the solid surface, less plaster is forced through the lath than with either wire or expanded-metal lath. The back cannot be covered with plaster and is therefore exposed to corrosion.

**33. Application of Sheet-Metal Lath.**—In general, the application of sheet-metal lath is similar to that for expanded-metal lath, except that nails are generally used in place of staples. The lath may be attached to wood supports, such as furring, joists, or studs, or to metal supports.

#### WIRE LATH

**34. Plain Wire Lath.**—Plain wire lath, sometimes called *metal fabric*, consists of wires that are woven together to form square or rectangular meshes. The wires are usually spaced  $\frac{4}{16}$  inch on centers, leaving spaces about  $\frac{3}{8}$  inch square, and producing what is technically termed *two-and-one-half mesh to the inch* (five wires to 2 inches). The wire is No. 20 gauge, the diameter of the finished material being .035 inch. Another spacing is two mesh to the inch ( $\frac{1}{2}$  inch on centers), the lath being made of No. 18 gauge wire, which is .047 inch in diameter.

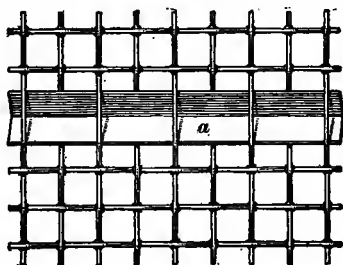

FIG. 34

**35. Stiffened Wire Lath.** Wire lath is better when stiffened so that it will not yield when the plaster is applied. Stiffeners are therefore woven into the lath at intervals of  $7\frac{1}{2}$  to 8 inches. These stiffeners are in the form of round rods, or of V-shaped strips as illustrated at *a* in Figs. 34 and 35. This stiffening is part of the lath and does not take the place of furring.

In Fig. 34 is shown a panel of V-stiffened lath before the plaster has been applied, and in Fig. 35 is shown a back view

after the plaster has been applied. The metal is entirely embedded in the plaster, and is thus protected from rusting.

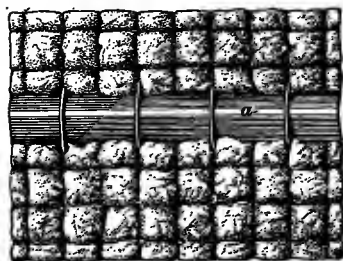

FIG. 35

Wire lath, both the plain and the stiffened, is furnished usually in rolls 150 feet in length, the stock width of the lath being 36 inches. When plain lath is to be used, the supports to which it is applied should be spaced not over 12 inches on centers, while if the stiffened lath is used the supports may be 16 inches on centers.

**36. Application of Wire Lath.**—In applying plain wire lath to wooden supports,  $\frac{3}{4}$ -inch round-top staples, as shown in (a), Fig. 36, are used generally, and fastenings are made at 6-inch intervals. The stiffened lath should be secured at each stiffener by means of  $1\frac{1}{4}$ -inch staples of the form shown in b. These staples will span the stiffeners. Lath that is applied to metal supports should be tied with No. 18 gauge galvanized annealed wire, plain lath being secured at 6-inch intervals, and stiffened lath secured at each stiffener. The lath should be lapped about 6 inches around corners and angles to minimize the cracking of plaster at such places.

**37. Characteristics of Metal Lath in General.** Metal lath is extensively used in fireproofing, and is valuable also in wood frame construction from the fact that plaster applied to metal lath is not liable to be injured by the usual shrinkage of the framing timbers. Plaster becomes firmly attached to all forms of metal lath, and ordinary accidents will not cause it to break away or become loosened. Metal lath is peculiarly adaptable to suspended ceilings, lending itself readily to bending into shapes to conform to the various moldings, panelings, etc., of an ornamental ceiling.

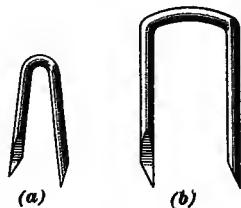
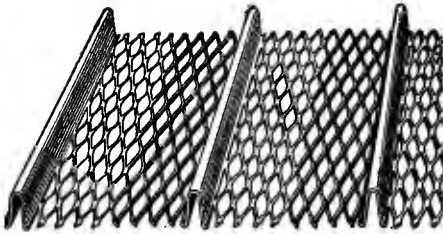

FIG. 36

In frame construction, metal lath gives to the plastered wall and ceiling two vital qualities, namely: permanence, or resistance to cracks, and resistance to fire. There are certain portions of buildings, notably dwellings, that are more vulnerable than others, and metal lath can be used in these places or parts at very little extra expense. Thus, metal lath may be used to prevent cracks in the plaster on the ceilings of prominent rooms, and it may be bent around and lapped 6 inches on either side of wall and partition angles, and around door bucks. It may be placed back of wainscots and tile mantels, across ducts for plumbing and heating plants, or as a foundation for stucco.

For use as fire-stops, or to prevent the spread of fire, metal lath may be used on all bearing partitions, and on all exterior walls. The bases of such partitions and walls may have metal-lath baskets for holding incombustible materials. Metal lath may be used for ceilings under much used rooms, and especially when the ceilings are over heating plants and coal bins. At chimney breasts and flues, and back of kitchen ranges, metal lath tends to prevent fire or heat from reaching the woodwork. Stair walls and soffits may be covered with metal lath. The use of metal lath for exterior walls will aid in preventing fire from reaching the woodwork of the building from the outside.

Wire lath and expanded-metal lath, as will be seen by reference to Figs. 24, 25, and 26, require more plaster than wooden lath or sheet-metal lath. This, however, is an advantage, for the plaster, which is a fireproofing material, nearly or completely encloses the lath, protecting it both on the face and on the back from exposure to fire and moisture. Metal lath entirely embedded in plaster will protect woodwork from fire for a considerable time. For this reason it should be placed back of ranges and stoves and their pipes, and should be separated by metal furring at least  $\frac{3}{4}$  inch from the woodwork it is to protect. The Underwriters Laboratories, representing the fire insurance companies of the United States, consider that metal lath and plaster will protect woodwork from fire for a period of at least one hour.



(a)

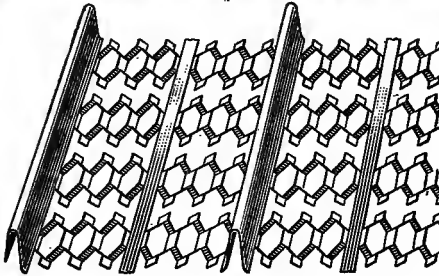

(b)

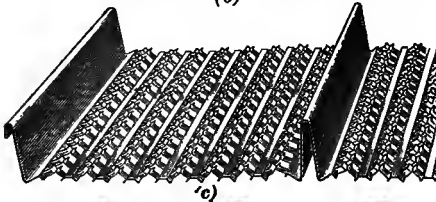

(c)

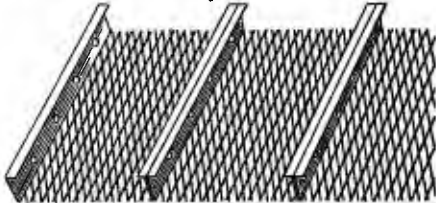

(d)

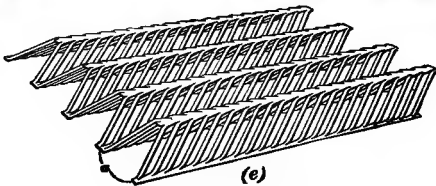

(e)

FIG. 37

### REINFORCED OR RIBBED METAL LATH

38. Most of the forms of metal lath already shown are also manufactured with ribs or projections which are designed to act as furring or even as studs. This material, while here classified as metal lath, is better described as combination furring and lath and combination studding and lathing.

39. **Reinforced Expanded Metal.** In Fig. 37 are shown several examples of expanded metal having ribs of various designs. When the ribs are small, as in (a) and (b), they act as furring strips. The use of this material as combination furring and lath is illustrated in Fig. 6. Its use as combination lathing and studding is shown in Fig. 38. In this case the metal is entirely embedded in the plaster, which is 2 or more inches thick.



The styles of reinforced expanded metal lath shown in (a), (b), and (c) in Fig. 37 have V-shaped ribs of different heights. A material known as *Chanelath* is shown at (d). This has T-shaped ribs spaced at intervals of 4 to 8 inches.

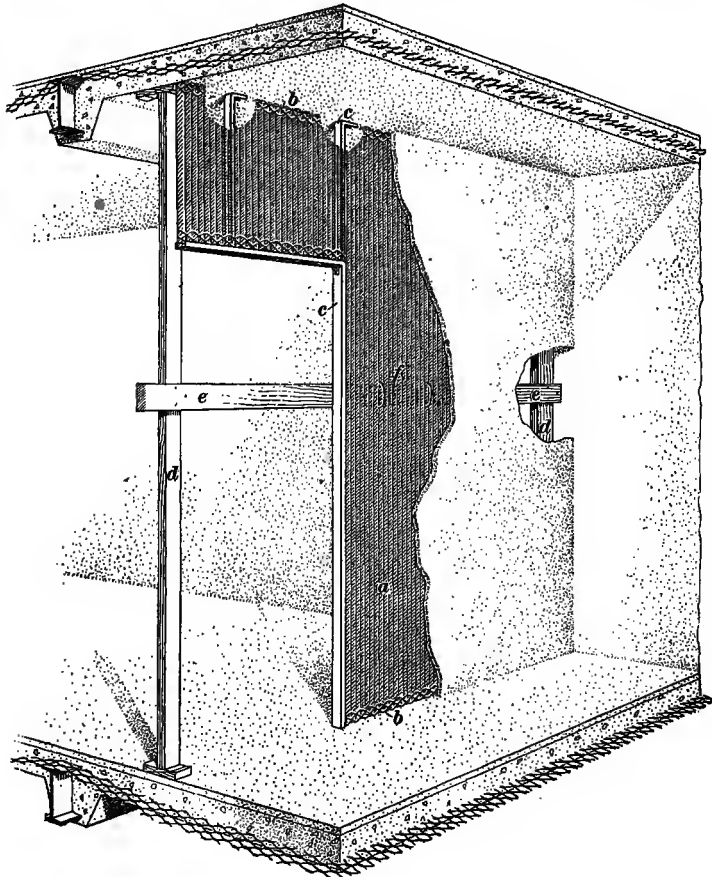

FIG. 38

*Trussit* (e) is a herringbone lath bent so as to be quite stiff. It is adapted to forming partitions and is embedded in solid plaster from 2 to 3½ inches thick.

Fig. 38 illustrates the application of trussit to a solid partition. The trussit, a, is fastened to the floor and ceiling by the

metal forms *b*. Metal studding *c* must be used around door or other openings. Temporary bracing *d* and *e* is wired to the lath as at *f* to hold the partition until the plaster is in place.

The forms of reinforced lath shown in (*a*), (*b*), (*c*), and (*d*), Fig. 37, are used as furring and lathing. The ribs are usually spaced from 4 to 8 inches apart and are from  $\frac{5}{16}$  to  $1\frac{1}{2}$  inches high.

**40. Reinforced or Ribbed Sheet-Metal Lath.**—Most forms of sheet-metal lath are also made with deep ribs, usually spaced 4 or 8 inches on centers, similar in character and purpose to those described for expanded-metal lath. These ribs

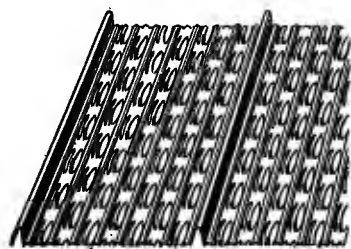

FIG. 39

take the place of furring on masonry walls. One form of ribbed sheet-metal lath is shown in Fig. 39.

As the ribbed sheet-metal lath is made usually with a rib at each edge, the sheets are lapped only the width of the rib. Staples should be used over the ribs, the length of the staple being about 1 inch more than the height of the rib.

Wire lath is not made with ribs as is done with expanded-metal or sheet-metal lath, and so it must be supported on furring or studding of metal or wood.

**41. Application of Ribbed Metal Lath.**—Joints between sheets of ribbed lath are formed by lapping the edge of one sheet over that of the sheet previously applied. The edges are then wired together and secured to the supports. In the case of Chanelath, shown in Fig. 37 (*d*), the edges of the sheets are butted together and wired. Where the ends of the sheets occur over supports, the lap is usually made 2 inches, otherwise a lap of 8 inches should be made, and the sheets wired together.

Ribbed forms of expanded-metal lath are adapted for use as a combined furring and lathing on masonry walls, as shown in Fig. 6. When used as bases for plaster to protect woodwork

against injury by fire, the ribs are fastened to the wooden supports, the remaining part of the lath being separated from the wood surface.

**42. Lath for Solid Partitions.**—To economize space, partitions between rooms or offices are sometimes made as thin as possible. In Fig. 28 the studs *a* are  $\frac{3}{4}$  in. hot- or cold-rolled channels. In Fig. 29 at *a* is a U-stud, and at *b* an angle stud which forms the jamb of the door. A similar angle forms the head of the door. These studs are fastened to the floor by means of a socket strip *c* and the tops are let into the ceiling. Wooden bucks *d* and *e* are secured to the angle studs by means of screws or bolts. Metal lath is stretched over the studs, the strips being placed horizontally. Grounds to which the base board may be fastened are shown at *f* and *g*. These grounds are placed on both sides of the metal lath *h*, and are nailed through into each other. The grounds *i* and *j* provide nailing places for a chair rail and for a picture molding. Upon this base the plastering is applied on both sides, and brought to the faces of the grounds.

---

### PLASTER BOARDS AND WALL BOARDS

**43.** Plaster boards are made of alternate layers of gypsum plaster, containing fiber, and strong fibrous felt, and are used as a substitute for lathing and the first coat of plaster. They are sometimes made with an interior core of gypsum mixed with fiber and with felt on the outside. This material is made in sheets generally 32 by 36 inches in size and from  $\frac{1}{4}$  to  $\frac{1}{2}$  inch in thickness. The board used for plastering should not be less than  $\frac{3}{8}$  inch thick. The outer surfaces of felt form a perfect bond with the plastering mortar. These boards can be readily sawed and nailed and are fastened directly to the studs, furring, or joists. The nails to be used are flat-headed nails  $1\frac{1}{4}$  inches in length which are coated to prevent rust. These boards should be set about  $\frac{1}{4}$  inch apart at the edges and should break joint horizontally. They should be nailed every 6 inches along the edges.

44. The advantages of using plaster boards are that they are non-conductors of heat and cold, and are fire-resisting. They save the expense of the lathing and the first coat of

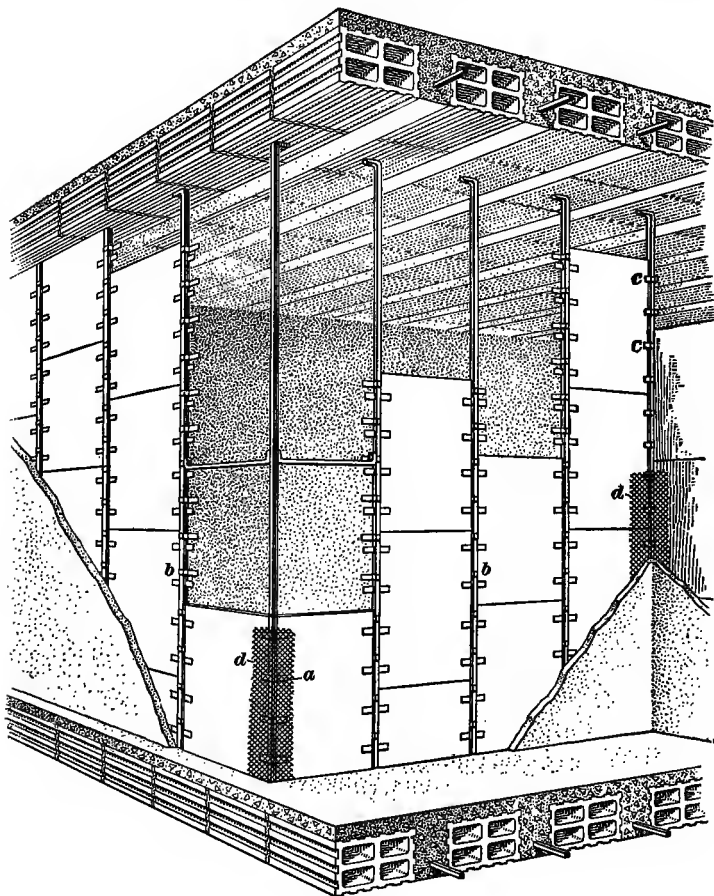

FIG. 40

plaster and avoid the moisture due to this coat of plaster. The time required for the first coat of plaster to dry is saved.

Wall boards are similar to plaster boards but are not plastered. They should be put on the studding, or furring,

so as to produce a paneled effect. The joints may be covered with wooden strips or else filled with a gypsum plaster and the entire surface papered. Wall boards are made 32 inches and 48 inches wide, and from 7 to 10 feet in length so that there will be as few joints as possible.

**45. Solid Partitions.**—Solid partitions may be made by fastening the plaster boards to channel supports, as shown in Fig. 40. The sheets commonly used for this purpose are 32 inches wide and 36 inches high. Clips, as shown in Fig. 41,

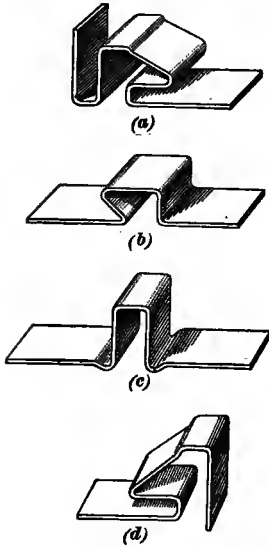

FIG. 41

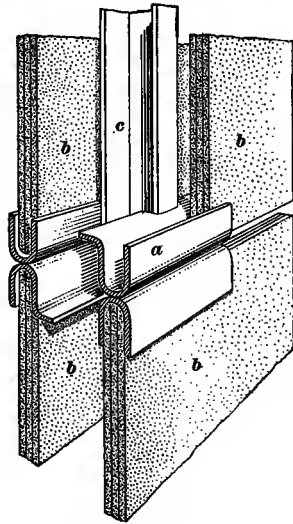

FIG. 42

are used to fasten the boards firmly to the supporting channels. The clip (a) is a corner clip, used in places as at a in Fig. 40. The clips (b) and (c), in Fig. 41, are used together in the plain surface, as at b in Fig. 40. Clip (d), Fig. 41, is used against walls, as at c in Fig. 40. These clips are spaced about 6 to 8 inches apart. To minimize shrinkage at corners, metal lath may be bent into angles or over corners, as at d, Fig. 40.

**46. Hollow Partitions.**—Hollow partitions may be built by nailing plaster boards to both sides of wooden

studding. When the studs are of metal, the boards may be held in place by clips. Fig 42 shows a portion of such a partition, the clip *a* holding the boards *b* to the channel stud, *c*.

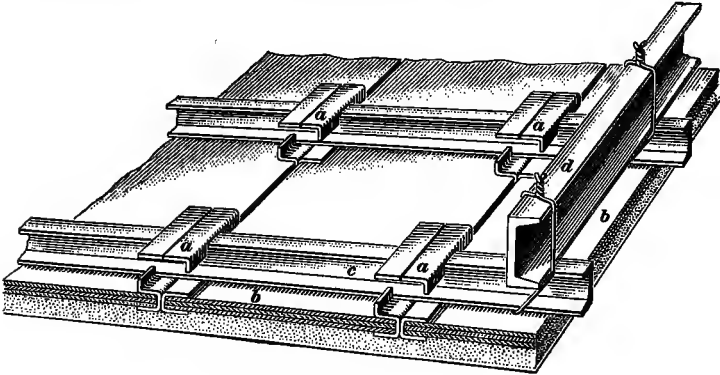

FIG. 43

**47. Suspended Ceilings.**—Plaster boards may be used for suspended ceilings by the use of clips *a*, in Fig. 43, which hold the boards *b*, the clips being attached to channels *c*, suspended at 16-inch centers from the carrying channels *d*.

---

## INTERIOR PLASTERING

---

### PLAIN PLASTERING

**48. Preparation for Plastering.**—The carpenters' specifications require, usually, that all surfaces shall be properly prepared for lath and plaster, and that suitable plaster grounds, such as are shown in Figs. 1 and 8, and at *a* in Fig. 44, shall be affixed to the masonry, or framework. Before plastering, the plasterer should test the alinement of the walls and ceilings, to see if there are concave surfaces which will require the application of an excessive thickness of plaster to bring the plaster to a plane surface. Also, to find out if there are places where the lath come too close to the finished surface, so that only a very thin coat of plaster can be applied. Where these irregularities occur, the lathing

should be removed, and the surfaces brought to true planes by blocking out, or cutting back, the furring strips under the lath.

Metal lath should be examined carefully to see that it is rigid, so that it will not buckle when the plaster is applied. The joints should be inspected to see that they are all properly fastened. The lath should be laid so as to afford a secure hold for the plaster, and the weight and finish of the lath should be checked to see that they are in accordance with the architects' specifications.

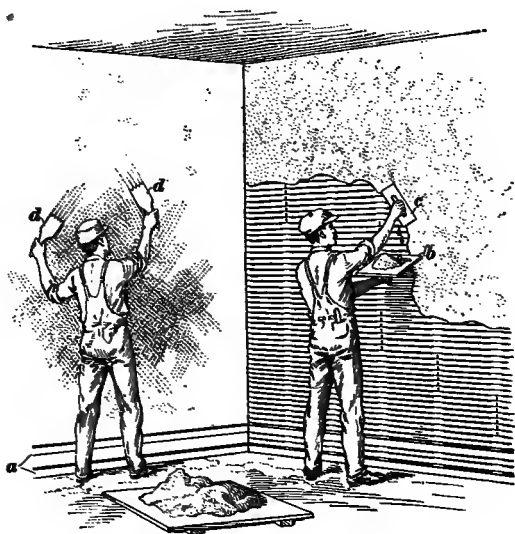

FIG. 44

Walls of masonry, hollow tile, or gypsum blocks should be plumb and true, especially if the plastering is to be applied directly to them. Walls that do not come out to their true planes may be made to do so by means of Portland cement mortar or gypsum plaster.

Plastering on wooden lathing should be begun as soon as possible after the lathing is completed. When such lathing stands too long, it is apt to dry out, making it necessary to wet the lath before plastering can be done.

When gypsum or cement plaster is to be applied to wooden lath, the lath, unless they are green, should be well watered, not merely sprinkled, a few hours before plastering, so that the lath will swell before the plaster has begun to set. When the lath are too dry, they will absorb moisture from the plaster, and swell after the plaster has begun to set, causing the plaster to crack and check.

Masonry surfaces, such as brick, concrete, tile, or gypsum blocks, upon which plastering is to be applied, should be brushed to remove all traces of dust, dirt, or loose particles, and sprinkled with water before applying the plaster. Too much moisture will prevent the proper adhesion of the plaster while, if too little is used, the walls will absorb too much water from the plaster, which then will dry out too fast. A good rule is to have the masonry as wet as it can be and leave no water standing on the surface. Whenever possible, in old work, the mortar joints of the masonry should be raked out to form a key for the plaster. In new work, it is necessary only to leave the joints roughened with the trowel but not struck.

**49. Protection from Weather.**—After it is on the wall, it is sometimes necessary to give the plaster protection from the weather, if the permanent sash are not in place. In hot, dry, and windy weather, plaster should be protected from air currents by closing the windows with muslin screens. With some quick-setting plasters, the surface should be sprinkled with water to prevent the plastering from drying out too much before it has set. In freezing weather, plaster must be protected from frost until it has set, or become hard. Usually, unless the regular sash are in place, it is the duty of the carpenter to close temporarily all of the openings in the outside walls with old sash, cloth screens, or other suitable materials. Temporary heat is also an advantage in cold weather. This can be easily provided if the heating apparatus of the building is installed. After the plastering has set, the doors and windows should be kept open, if the weather is not too cold, so that the plastering will thoroughly dry out.



## PLASTERERS' TOOLS

**50.** The implements used by the plasterer are simple and inexpensive, the principal ones being shown in Fig. 45.

In (a) is shown an ordinary *screen*, which is used for separating the coarser particles of sand and gravel from the finer ones. In (b) is shown a screen through which slaked lime is passed to free it from grit and unslaked particles.

**51.** The *hoe* and the *shovel*, shown in (c) and (d) respectively, are used for mixing the materials.

**52.** The *hawk*, shown in (e), is a piece of board about 10 inches square, provided with a short handle. It is used to hold small quantities of plaster, ready for applying with a trowel.

**53.** The ordinary *laying trowel*, shown in (f), is used for applying plaster to the walls. It is a thin plate of polished steel, about 10 inches long and  $4\frac{1}{2}$  inches wide, having a wooden handle. Various other forms of trowels, for gauging, pointing, etc., varying in length from 3 to 7 inches are shown in (g), (h), and (i).

**54.** *Floats* are used for smoothing, or *floating*, the surface of the second coat. In (j) is shown the *hand float*, which is merely a piece of board with a handle on the back. It is made usually of pine, but for producing the finished surface of very fine work, a cork face is sometimes used. For rough finish, the face of the float is covered sometimes with burlap, felt, or carpet. A *two-handled float*, called a *derby*, is shown in (k); this is a straightedged piece of wood, usually from 3 to 6 feet long, used for floating larger surfaces than can be worked readily with a one-handled float.

**55.** The *straightedge*, shown in (l), is a long piece of smooth board, having its under edge planed straight and true. It is used to test the walls and ceilings, in order to obtain plane surfaces.

**56.** The *square*, shown in (m), is used for testing the trueness of angles.

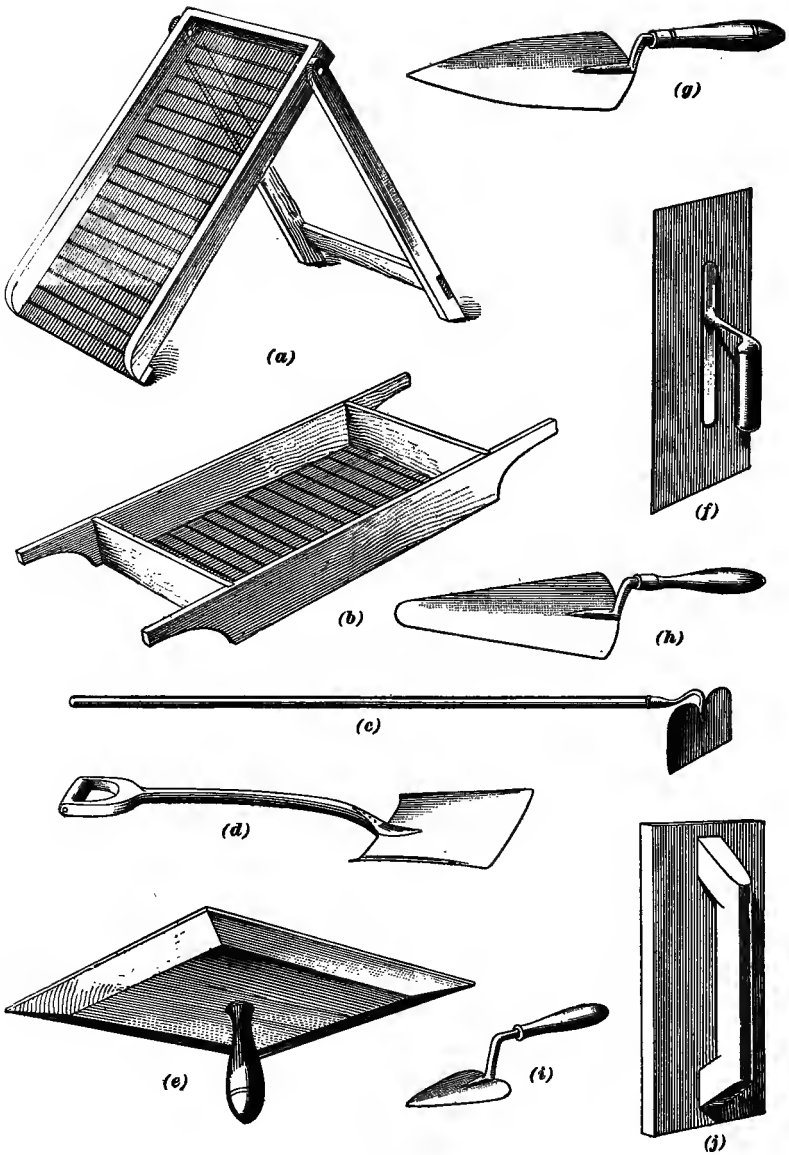

FIG. 45

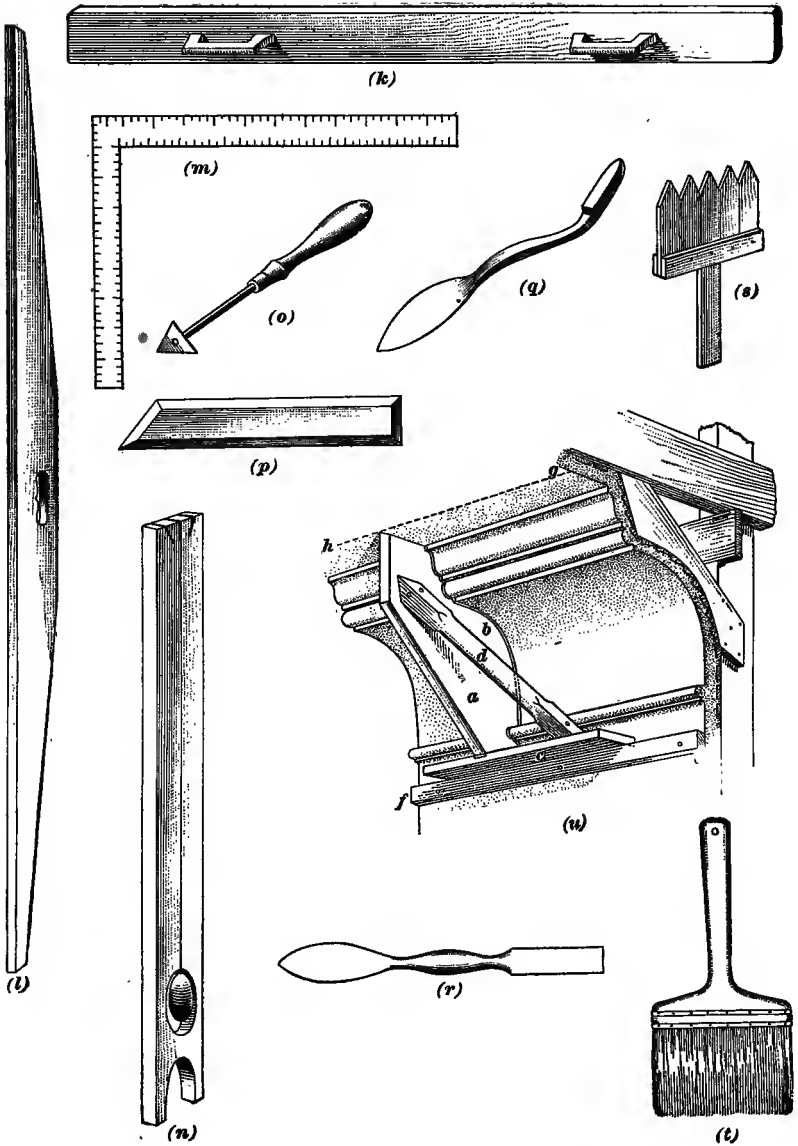

FIG. 45

57. The *plumb*, shown in (*n*), is used to determine whether or not the plastered surfaces are plumb by applying one of its straight sides to the surface. If the plumb-line, hanging freely, lies along a shallow groove cut in the face, parallel to the sides, the surfaces are true.

58. *Jointing and mitering tools*, shown in (*o*), (*p*), (*q*), and (*r*), are used for picking out and finishing angles and miters in moldings, etc.

59. The *comb*, shown in (*s*), is used for scratching the surfaces of the first and second coats of plaster, to form a good key for the ensuing coat. It consists merely of pieces of lath nailed together, and having one end sharpened, as shown.

60. *Brushes* of various kinds are used by the plasterer. That shown in (*t*) is used for dampening the surface of the plaster while it is being worked smooth.

61. *Templets* of various kinds are used for forming cornices and moldings. The templets are made of wood or sheet metal cut to the required outline, and are backed by wood. In (*u*) is shown one form of templet, which consists of a board *a*, to the beveled inner edge of which is attached a thin zinc or steel plate cut to the outline of the cornice, as at *b*. The strip *c* and the handle *d* brace the board *a* firmly and keep it square with the wall; *ef* represents a guide strip on which the strip *c* slides, and *gh*, a line drawn on the ceiling, flush with the outer edge of the board *a*, which is kept along this line. The frame of this templet, consisting of the pieces *a*, *c*, and *d*, is known sometimes as a *horse*. Templets are made either right-hand, as shown, to be pushed from right to left with the right hand, or left-hand, to be pushed from left to right with the left hand.

---

#### LIME PLASTER

62. **Definition.**—*Lime plaster* is a form of plaster the principal ingredient of which is lime. The lime is mixed with sand, hair, and water to form a plaster which is applied to the wall, or to the lathing. The finishing coat of plaster consists of lime, plaster of Paris, and sometimes marble dust.

**63. Characteristics.**—Lime plaster hardens gradually as the lime in the plaster absorbs carbon-dioxide gas from the air. Lime plaster requires considerable time to become thoroughly hardened. This, however, has certain advantages, as it gives the plasterer more time to true up his work, and the mortar can be retempered without destroying its efficiency. When properly made with good lime, lime plaster forms a serviceable wall, and is sometimes preferred to gypsum plasters.

**64. Lime.**—There are many kinds of lime on the market and care should be exercised in selecting the one to be used. Lime is generally slaked at the building, which requires time and space. It should be thoroughly slaked so that there will be no unslaked particles of lime in the plaster. If unslaked particles occur in the plaster they are apt to slake after the plaster has been placed on the wall and force pieces of plaster off the wall. This is known as *popping*, or *pitting*.

When the lime is slaked it is generally in the form of a paste, called *lime paste*.

**65. Hydrated Lime.**—In place of lump lime, hydrated lime may be used. Hydrated lime is lime that has been slaked by machinery. Hydrated lime is used extensively in the preparation of the first and second coats of lime plaster, and some especially prepared brands are used in the mixture for the finishing coats of plaster, and in ornamental work. Wherever lump lime can be used in the various plaster mixtures described in the succeeding articles, hydrated lime may be used, and the time and space required for slaking the lime can be saved.

**66. Coarse Stuff.**—Coarse stuff is used for the first coats of plaster, and is made by mixing the proper quantities of sand and well beaten hair with lime paste.

**67. Fine Stuff.**—Fine stuff is used in the preparation of the finishing coat of plaster. It consists of lime paste that has been diluted with water until it is as thin as cream. The substance is then allowed to settle. When the surplus water

appears clean and the lime held in suspension has settled, the water is drained off. The moisture in the mass is then allowed to evaporate until the paste becomes sufficiently stiff for use.

**68. Plasterers' Putty.**—Plasterers' putty, or lime putty, is practically fine stuff except that the creamy fluid has been strained through a fine sieve. This makes the paste much more velvety than fine stuff.

**69. Gauged Stuff.**—Gauged stuff for the finished coating of walls and ceilings consists of about three-fourths fine stuff or plasterers' putty, and about one-fourth plaster of Paris. The plaster of Paris causes the mixture to set quickly, and the mixture must be used immediately. No more should be prepared than can be applied in 20 or 30 minutes.

**70. Hair and Fiber.**—Hair and fiber are used in plaster for the reason that plaster does not possess sufficient cohesive power to bind it together firmly until it has hardened or set. Hair is used largely for this purpose. Cattle hides are the chief source from which plastering hair is obtained. After being cleansed of all grease, the hair is washed and dried, and packed into bags that hold a bushel, measured loose, and weigh from 6 to 8 pounds.

Manila fiber is probably the best, but it is somewhat expensive. Sisal, obtained from a species of cactus, is an excellent fiber and is frequently used. Cottonwood and coconut fiber are also used, although much bulkier than hair. Gypsum plasters usually contain either Manila, jute, wood, or asbestos fiber as a binding material.

**71. Water.**—Water used in the preparation of plaster should be clean and free from oil, acid, strong alkalis, or vegetable matter. Such substances affect the strength of the plaster as well as the rate of setting.

**72. Sand.**—Sand for plastering should be angular, of medium fineness, and clean, but above all it should be graded from fine to coarse in size of particles. Before using, all sand should be screened to remove the too coarse particles,

and, if wanted for use in the finishing coat of plaster, it should be passed through a fine sieve. The best plaster is made from screened, washed, and dried sand. White sand is used sometimes to give a firm, white surface to the finishing coat of plaster, and marble dust is used for the same purpose.

**73. Quantities of Materials Required.**—The scratch and brown coats of lime plaster together, when laid on wood lath having  $\frac{3}{4}$ -inch grounds, will require about 600 pounds of lime, 3,600 pounds of sand, and 24 pounds of hair, or 16 pounds of hair and 8 pounds of fiber for 100 square yards of surface. Metal lath will require about 700 pounds of lime, 4,200 pounds of sand, and 28 pounds of hair for the two coats for the same area. The quantities given are approximate only, as lime and sand vary in different sections of the country.

---

#### GYPSUM PLASTER

**74. Definition.**—*Gypsum plaster* is a form of plaster, the principal ingredient of which is gypsum. It is a quick-setting, hard, plaster which is delivered at the building in a dry state and is made ready for use by the addition of water, or sand and water.

Gypsum plasters are also known as *cement plasters*, *patent plasters*, *prepared hard plasters*, and *hard wall plasters*.

**75. Manufacture.**—Gypsum plasters are made of gypsum rock which is found in many parts of the world. This rock is ground and calcined, or burned, and some of the water in its composition is driven off. The product is then mixed with a binder and a retarder. The binder consists of hair or fiber to give tenacity to the plaster while setting. The retarder is a material that is added to prevent the plaster from setting or getting hard too quickly. These materials are weighed and thoroughly mixed together by machinery, thus assuring a uniform product.

Gypsum plaster is put up in jute bags containing 100 and 125 lb., in paper bags containing 80 lb. and in barrels containing from 250 to 300 lb.

After the plaster has been used, the jute bags, if in good condition, can be returned to the manufacturer and a credit obtained for them.

**76. Characteristics.**—The product is uniform in quality and when mixed and applied according to the directions given by the manufacturers, produces dependable results. Gypsum plasters, like Portland cement, set quickly, whereas lime plastering hardens gradually by contact with the air. The quick setting of hard plasters permits the application of succeeding coats in a very short time, thus permitting a saving in time. Walls made of these plasters are very hard and strong compared with walls covered with lime plasters, and are fire resisting. In large buildings the dry materials may be distributed about the building, the adding of water and the mixing being done near the place where the plaster is to be applied.

**77. Forms of Hard Plasters.**—Gypsum plasters are made and sold in various forms, such as *neat*, or unsanded; *prepared*, or *sanded*; *wood fiber plasters*, and *bond plasters*.

Neat, or unsanded, plaster contains no sand and both sand and water must be added in the proper proportions to make it ready for use. When good sand is found in the neighborhood of the building that is being plastered, neat cement can be ordered to advantage and sand added at the building. This form of gypsum plaster is most generally used. Care should be taken not to add too much sand to the plaster as it is delivered in the package. The manufacturers usually stipulate the amount of sand that should be added.

Prepared, or sanded, plaster is neat plaster to which a proper amount of sand has been added by the manufacturer. Only water is added in preparing it for use. The manufacturer usually has facilities for obtaining sand of a suitable quality and can screen, wash, dry, and mix it with the plaster by machinery. In neighborhoods where good sand cannot be obtained, it is advisable to use the prepared plaster. The cost of sanded plaster is increased by the freight charges when it must be delivered a great distance from the factory.



Wood fiber plasters contain finely shredded wood fiber in place of the sand used in prepared plasters. The wood fiber gives to the plaster elasticity, toughness, lightness and strength. It also makes the plaster easier to apply. It is generally used without the addition of sand, but in some makes of wood-fiber plaster, sand may be added, using one part plaster to one part sand.

**78. Bond Plaster.**—Bond plasters, known as *concrete plasters*, are gypsum plasters manufactured especially for the first, or scratch, coat of plaster on concrete surfaces. These plasters adhere strongly to the relatively smooth surfaces to which ordinary plaster will not hold. They furnish bases to which the regular gypsum plaster will adhere. Bond plasters are sold neat or mixed with sand.

**79. Plaster of Paris.**—While not a wall plaster, plaster of Paris is used in connection with the finishing of plastered walls and is a gypsum product. It is used particularly in the finishing coat of walls and in ornamental plastering. It is mixed with a certain proportion of lime paste and sand, in forming cornices, moldings, and enrichments as well as for plain surfaces.

Plaster of Paris is unsuited for exterior work, as it is slightly soluble in water. It is mixed with lime paste and with finishing plaster to cause them to set more quickly.

**80. Mixing Gypsum Plasters.**—Plaster is mixed in a shallow box, one end of which is raised about 4 to 6 in., and the dry materials placed in the high end. Water is placed in the low end of the box, and the plaster hoed down into it, plaster being added until the mass is thoroughly mixed and of the proper consistency. When unsanded plaster is used, sand is added to the plaster and the whole mixed thoroughly while dry. Small quantities should be mixed with water at one time. No more should be mixed than can be used handily in about 1 hour.

**81. Proportions.**—For ordinary work with unsanded plaster, two parts of sand are mixed with one part of gypsum

for the scratch coat on wood or metal lath, or on plaster boards. Three parts of sand and one part of gypsum are mixed for the first coat on brick, tile, or gypsum blocks, and for the second coat on all walls.

---

#### APPLICATION OF LIME PLASTER

**82. Names of Coats.**—Lime and gypsum plasters are applied usually in three coats, the first being called the *scratch* coat; the second, the *brown, straightening, or floated*, coat; and the third, the *skim, white, or finishing*, coat. In some cases two coats only are used, the first coat being straightened and smoothed carefully to receive the finishing coat. On masonry, the separate scratch coat is usually omitted, but when applied is called the *rendering* coat. When combined with the brown coat on masonry, the first coat is called a *scratch-and-brown* coat.

**83. Scratch Coat.**—The method of applying the scratch coat of lime plaster to wood lath is illustrated in Fig. 44. The plaster, mixed to the proper degree of firmness in the mixing box, is carried to mortar boards, shown on the floor. A quantity of the plaster is placed on the wooden hand board, or hawk *b*, by means of the trowel *c*. The plasterer then takes small quantities of the mixed mortar on his trowel and spreads them firmly and evenly over the surface of the lathing. The plaster should hold together well, and yet be soft enough to be pressed in between the laths, so that it will bulge out behind the laths sufficiently to form a clinch or key. The thickness of the layer should be fully  $\frac{1}{4}$  inch in front of the lath so that when it is set it will furnish a rigid surface upon which to apply the succeeding coats. After the first coat has somewhat hardened, it is scratched with comb-like blades *d*, in Fig. 44. From this operation, the first coat is called the scratch coat. The scratches or grooves form a key for the plaster of the next coat.

When a scratch coat is applied to a masonry wall, the plaster should be forced into all the joints and crevices, which serve the same purpose as the openings in the lathing.

**84. Brown Coat.**—The second, or brown, coat of lime plaster consists of coarse stuff to which a larger proportion of sand and somewhat less hair has been added than was used for the scratch coat. It should be about  $\frac{1}{4}$  inch thick, and should be compacted firmly by rubbing with the float *g*, Fig. 46. Should the coat become dry during the process, it is moistened by applying water with the wide brush shown in *t*, Fig. 45.

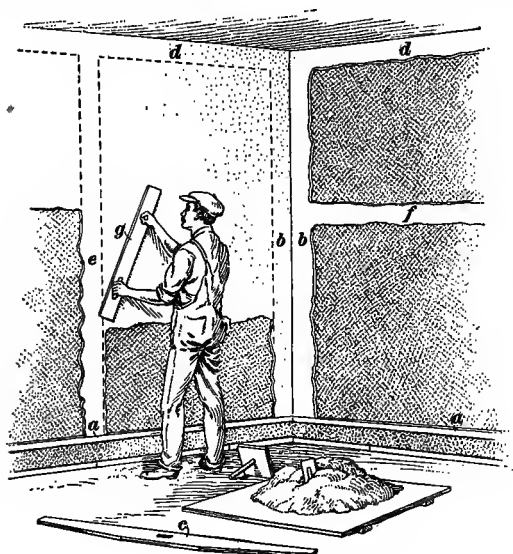

FIG. 46

On masonry walls, the brown coat is built out to the desired plane ready for the finishing coat, with as little rubbing as possible.

**85. Green Work, or Laid-off Work.**—Sometimes the brown coat is put on immediately after the scratch coat, without allowing time for the latter to dry out. This is known as *green work*, or *laid-off work*. In such cases, the first coat is made very rich in lime, while the brown coat contains a larger proportion of sand. The brown coat is worked into the scratch coat so as to form practically one coat.

Laid-off work is a less expensive form of three-coat work because of the fact that the same scaffolding can be used for the first two coats. The second, or brown, coat can be applied while the first, or scratch, coat is yet fresh.

**86. Screeds.**—In order to obtain true walls and ceilings, especially in large surfaces, where the grounds are far apart, the process known as *screeding* is employed. *Screeds* are plaster bands made of brown coat material formed on the scratch coat. They are 5 or 6 inches wide, and are shown at *b*, *d*, *e*, and *f* in Fig. 46. The screeds *b* are built up on the scratch coat at the angles, and are plumbed carefully from the grounds *a* by means of the straightedge *c*. They are kept back, however, about  $\frac{1}{8}$  inch from the finished face of the grounds, to allow for the finishing coat. The horizontal screeds *d*, are formed at the ceiling angles. Intermediate vertical and horizontal screeds are also made as at *e* and *f*. Screeds are placed usually 4 to 8 feet apart, and form a true plane. The spaces between the screeds are filled in, flush with the screeds, and rubbed down with the two-handed float, or derby *g*.

Ceilings are treated in a manner similar to that used on the side walls, the screeds being leveled carefully.

When the scratch and brown coats are applied as one coat, as already mentioned, the screeds are built out before the panels are filled, the general method being the same as just described.

The space between the plaster grounds *a*, for the baseboards, and the floor, is finished, usually, only with a scratch and a brown coat of plaster.

**87. Finishing Coat.**—The finishing coat is the one that is visible, and it is made, generally, so as to give a pleasing finish to the wall, and to provide a good surface upon which to apply paint, papering, or other decorations. There are several kinds of finishing coats, known as *skim coat*, *sand finish*, and *hard-finished white coat*. In all cases the material is applied to the surface in the form of a stiff paste by means of the trowel *a*, shown in Fig. 47, and is spread uniformly over the surface of the brown coat to a thickness of about

$\frac{1}{8}$  inch, bringing the finished surface of the plastering out to the lines of the grounds. These finishes should be applied after the brown coat is dry.

88. **Skim-coat finish** consists of lime putty and very fine, white, sand. Usually, a little plaster of Paris is added to hasten the set and to form a harder surface. When the plaster is added, the sand is usually omitted. This mixture is polished to a glazed surface with a steel trowel *b*, the surface being kept moist by water applied with the brush *c*. For

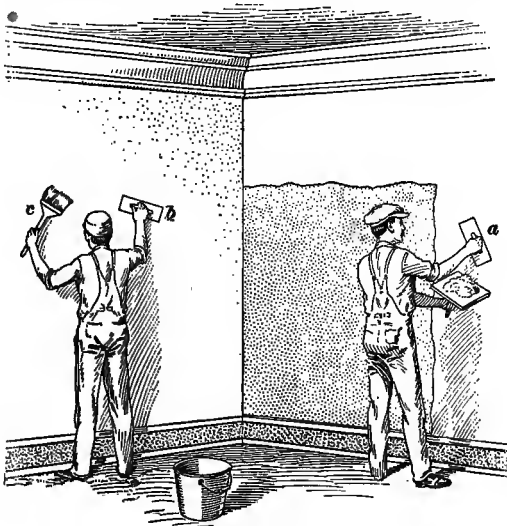

FIG. 47

100 square yards of surface, there will be required about 200 pounds of lump lime or 300 pounds of hydrated lime, 50 to 100 pounds of plaster of Paris, and 50 to 100 pounds of white sand.

89. **Sand finish** consists of gauged lime putty and sand, and is usually finished with a wood- or cork-faced trowel. Sand finishes may be fine or coarse as desired, the finish of the surface being determined by the sand that is used. This surface is sometimes obtained by covering the hand float *j*,

Fig. 45, with a piece of carpet, burlap, or felt, which will cause the sand to rise to the surface and present the characteristic sandpaper finish. About 200 pounds of lump lime, 50 to 100 pounds of plaster of Paris, and 400 to 500 pounds of sand, will be required for 100 square yards of surface.

**90. Hard-finished white coat** consists of 3 to 5 parts of lime putty gauged with 1 part of plaster of Paris, and to which marble dust or fine white sand has been added. This coating is smoothed and polished with the steel trowel. Marble dust gives a surface susceptible to a high polish. About 200 pounds of lump lime, 75 to 100 pounds of plaster of Paris, and 50 to 75 pounds of marble dust or sand will be required for 100 square yards of surface.

Sometimes the finishing coat is omitted in cheap work, the brown coat being brought to the line of the grounds and made as smooth as possible. This treatment saves the expense of applying the finishing coat of white plaster.

---

#### APPLICATION OF GYPSUM PLASTERS

**91.** The general processes used in applying lime plaster are also used in the application of gypsum plasters. Lime plaster hardens and dries somewhat slowly by contact with the air. It hardens by absorbing and combining with carbon dioxide in the air, and does not become thoroughly hardened for several months.

Gypsum plaster, on the other hand, sets in the same manner as Portland cement, and, although it may still be wet or moist, it may be thoroughly set and hard. The time required for gypsum plaster to set can be regulated by the addition of different substances. The manufacturers arrange the time of setting so that their product will set in a fixed time which will yield the best results. Hence, with gypsum plaster, the second, or brown, coat can be applied over the scratch coat within 2 or 3 hours after the first coat has been applied, even though the first coat is still wet. However, the first coat should be set and hard. The first coat should be scratched before the material has set.

If the first coat is allowed to stand until it is too dry, it should be sprinkled with water before applying the second coat.

The second, or brown, coat, also called the *float*ed coat and the *straightening coat*, is about  $\frac{1}{4}$  inch thick. The same methods are used in screeding and straightening this coat as have just been described for lime plastering.

Solid partitions are formed by applying a scratch coat and a brown coat to the studding and lathing shown in Fig. 29. The plaster is brought out to within  $\frac{1}{8}$  inch of the faces of the grounds, to allow for the finishing coat.

The finishing coats described for lime plastering may be applied to gypsum brown coats. Manufacturers supply ready-mixed finishes for use with their plasters. They also give directions for their proper use, and for finding the quantities of materials required.

---

#### KEENE'S CEMENT

**92.** Keene's cement is made by recalcining plaster of Paris which has been saturated with a solution of alum. When properly applied, the material becomes very hard and takes a high polish. Its hardness makes it a satisfactory material to use for finishing the lower portions of walls where the surface is liable to injury, as in kitchens and bathrooms. In such cases, the surfaces of the plaster are marked off with lines to imitate the joints of tile work.

**93.** Keene's cement is made in four grades, as follows: *Regular*, for general plastering purposes; *fine*, for wainscots, columns, extra white finish, and for backing artificial marble; *superfine*, for facing artificial marble; and *quickset*, for castings and moldings. The regular grade is commonly used for plastering the plane surfaces which occur in ordinary work.

**94. Application.**—Keene's cement may be applied on brick, stone, concrete, hollow tile, or gypsum blocks, or to wood or metal lath. The general methods and the tools used for lime or gypsum plastering are employed in applying Keene's cement plaster.

The first, or scratch, coat of Keene's cement plaster is mixed in the proportions of 1 cubic foot of Keene's cement, 1 cubic foot of dry hydrated lime, 5 cubic feet of sand, and about  $\frac{3}{4}$  bushel of hair. The first coat should be well scratched and allowed to harden before the second is applied.

The proportions for the second, or brown, coat are: 1 part of Keene's cement, 1 part dry hydrated lime, and 7 parts sand. This coat should be allowed to dry before the final, or finishing, coat is applied.

**95. Finishes.**—The finishing coat of Keene's cement may be one of three, known as *smooth* finish, *sand-float* finish, and *smooth-hard* finish. Any one of these three may be applied to gypsum plaster or lime plaster brown coats, to a Portland cement base, or to the second coat of Keene's cement.

To secure the smooth finish, the finishing coat is composed of 4 parts Keene's cement, to which is added 1 part of dry hydrated lime. When nearly set, the coat is troweled to a smooth polished surface.

The sand-float finish is obtained by mixing 1 part of Keene's cement with 1 part of dry hydrated lime, and not more than 7 parts sand. The surface is brought to the desired finish with a wood or cork float. The texture and color of the sand used will appear in the finished surface.

For the smooth hard finish, Keene's cement is used neat, that is, without the addition of either lime or sand. The finish coat is troweled to the desired finish.

All the above are mixed with suitable quantities of clean water.

---

#### PORTLAND CEMENT PLASTER

**96.** Portland cement plaster is used mainly on account of its hardness, and for its fireproofing and water proofing qualities. This plaster requires only a few hours to set, and in setting it combines with the water used in mixing. One or two days' interval between the application of the coats is all that is required.



**97. Materials.**—The materials used in making Portland cement plaster are Portland cement, sand, hydrated lime, and water. In some cases a special waterproofing material is added. The hydrated lime has a waterproofing value, and it is used also to give the mixture smoother working qualities.

**98. Proportions.**—The usual proportions for Portland cement plaster are 1 part Portland cement  $\frac{1}{10}$  part hydrated lime, and  $2\frac{1}{2}$  parts sand.

**99. Application.**—Portland cement plaster is applied usually in two or three coats, each coat being applied in thin layers and built up to the full thickness. No more plaster should be mixed than can be applied in 20 or 30 minutes, as the plaster should not be applied after it has begun to set. Each coat should be scratched and allowed to set, but not to dry, before the next coat is applied.

**100. Finishes.**—Either of two finishes, known as *smooth-troweled* and *stippled*, may be given to the final coat of Portland cement plaster.

The smooth-troweled finish is secured by allowing the cement to harden partly, but not to acquire its initial set. The surface is then troweled smooth with as little rubbing as possible. Too much rubbing is apt to bring the water and cement to the surface, resulting in an unsatisfactory finish.

A stippled finish may be given the surface by first troweling as is done for a smooth-troweled finish. While the surface is still moist, it is patted lightly with the end of a brush of broom straw.

---

#### CAEN STONE CEMENT

**101.** Natural Caen stone, found in France, possesses a texture and color that is very pleasing and satisfactory for interior decoration. It is crushed and mixed with special cements and chemicals and applied in the form of plaster to the interior surfaces of walls. It is generally used to imitate the stone from which it is made. After it has been applied to walls, imitation joints are cut in the surface and are filled with Keene's cement. This treatment results in a fine creamy

limestone effect that is extremely attractive. Moldings are run in the same manner as is done with plaster. The surface is sometimes scratched to represent 8- or 10-cut limestone work, or it may have a rubbed finish. The Caen stone cement is applied over a base of Keene's cement plaster and is about  $\frac{1}{4}$  inch thick. It is brought to a true surface in the same manner as standard plaster. After the joints have been finished, the whole surface is rubbed smooth with sandpaper. The work of applying and finishing Caen stone requires high-class workmanship and experience.

---

## ORNAMENTAL PLASTERING

---

### MATERIALS AND PREPARATION

**102. Definition.**—As already defined, ornamental plastering is the art of forming ornament in plaster on plain surfaces. This ornament is in the form of moldings, cornices, paneling, pilasters, and other architectural and decorative features which add to the interior of a building.

**103. Materials.**—The principal materials used for ornamental plaster work are plaster of Paris, lime paste, and some of the finer kinds of gypsum plasters. The tools used for forming the ornament have already been described.

**104. Cornices and moldings** are run by the plasterer as will be described later. Ornaments, columns, pilasters, and sometimes moldings are cast at the shop and brought to the building ready to be set in place. Other ornaments are manufactured and kept in stock and are ordered from catalogs or samples. These also are brought to the building and set in place by the plasterer.

**105. Preparation for Moldings and Cornices.**—Cornices and moldings are made, or run, in place, usually before the finishing coat is applied. Where the extreme projection of the molding or cornice is less than 2 inches from the finished wall, or ceiling, the core is formed of coarse stuff, or of brown

coat. The finished surface of the cornice is formed by running a thin coating of finishing material over this core.

**106.** When the projection of the cornice is several inches, a base of wood blocking is formed to which lath is attached, and this base is coated with the scratch and brown coats. This rough plastering is brought within  $\frac{1}{4}$  inch of the finished surface and upon this base the finishing coat is run so as to produce the desired cornice.

**107.** In Fig. 48 is shown a cornice of small projection, which is run against the brown coat of the wall *a* and ceiling *b*. A core *c* is run with a muffled trowel, described later, and

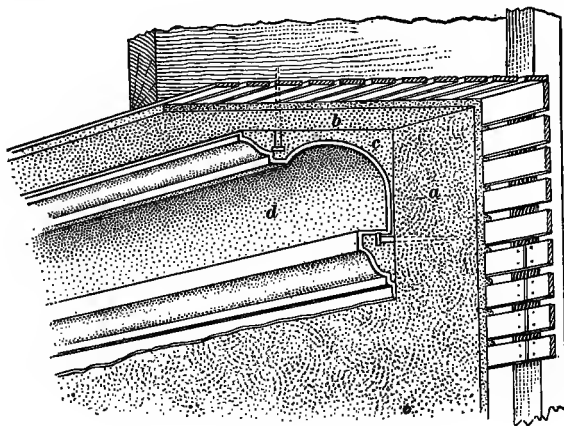

FIG. 48

may be made of coarse stuff or of a mixture of plaster of Paris and lime paste of which the finished cornice is to be made. If coarse stuff is used, it will be gauged, or mixed with plaster of Paris, so as to set rapidly. When this core is set, the cornice *d* will be run in finishing plaster and plaster of Paris and will form a true, clean, cornice.

**108.** The cornice in Fig. 49 can be run directly on the brown coat *a*, the thicker part *b* being formed of the finishing plaster of which the cornice is made. The picture molding *c* is placed so that it forms part of the cornice.

109 In Fig. 50, the base of the cornice is formed by nailing a strip of metal lath in the angle of the wall and ceiling

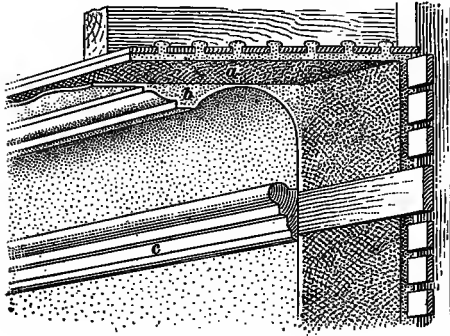

FIG. 49

so as to form a core. This lathing is applied before the plastering is started and is plastered with the first two coats when the remainder of the wall is plastered. The strip *a* is nailed on the ceilings to form a base for the projection *b* of the cornice.

The cornice is shown in section at *c* and is run directly on the brown coat *d*. At *e* and *f* are shown the guides that are used in directing the movement of the templet used in forming the cornice.

110. In Fig. 51 is shown a cornice with a considerable projection. It is *blocked out* with blocks *a* nailed to each joist above, or about 16 inches on centers. To this blocking the lathing is nailed and the entire lathed surface is coated with scratch and brown coat as shown at *b*. Upon this surface the finished cornice *c* is run.

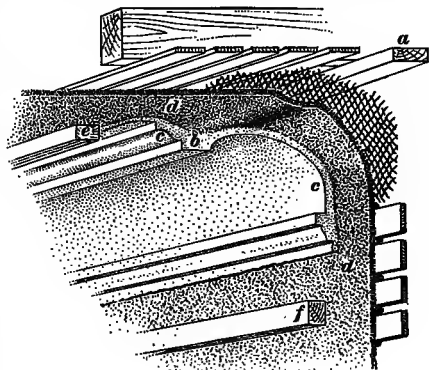

FIG. 50

111. **Preparation for Curved Ceilings.** Curved ceilings often require an intricate framing of light iron or steel in order to support properly the metal lath on

which the plaster and ornamental work is applied. Fig. 52 shows the furring necessary to form the large sweep of the

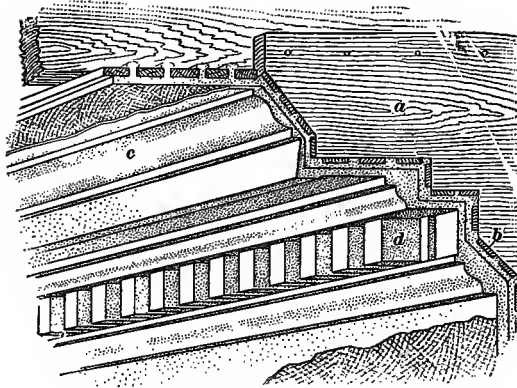

FIG. 51

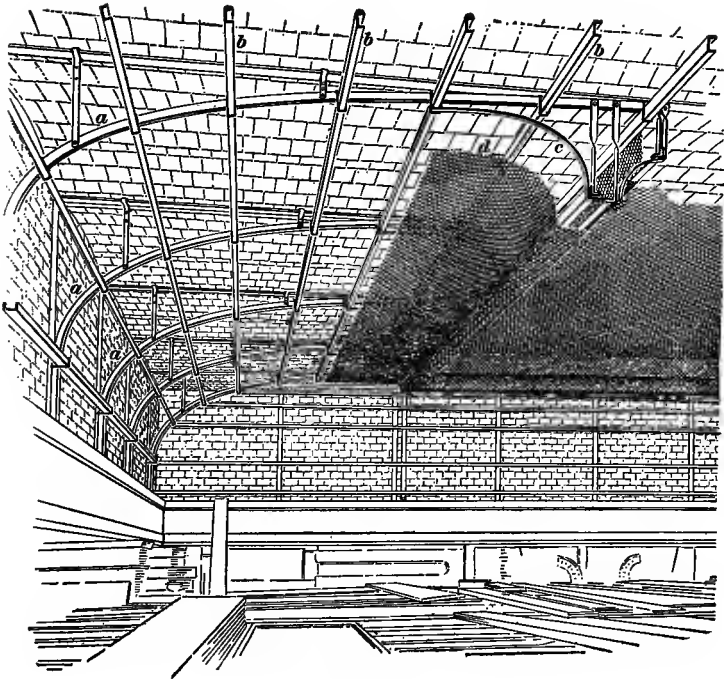

FIG. 52

coved ceiling and the ornamental cornices and beams. The curved bars *a* support the channels *b* and *c*, to which the metal lath *d* is attached. When this lathing is all applied, the plastering is carried on in the usual manner. In a ceiling such as the one shown, considerable ornamental plasterwork would be supported on the wire lath.

**112.** Curved surfaces may be formed in ribbed-metal lath when the construction requires a stiffer surface than will be furnished by the plain lath alone.

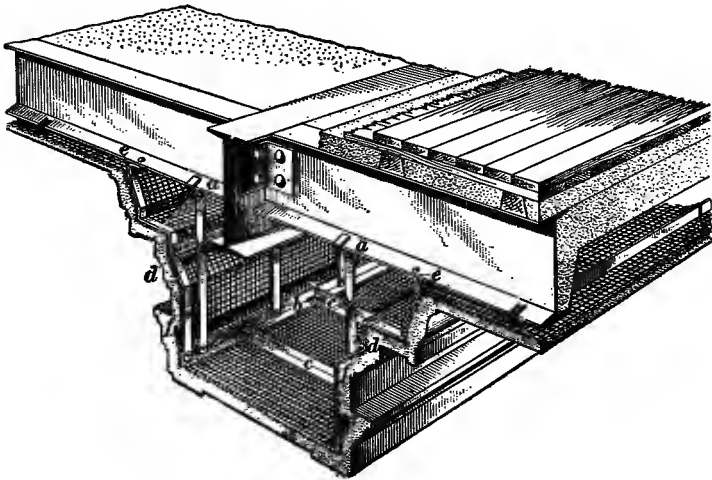

FIG. 53

**113. Preparation for False Beams.**—An elaborate beam construction is shown in Fig. 53. This is typical of work in fireproof buildings, where the use of wood must be reduced to a minimum. In this construction the hangers *a* are connected to horizontal angle bars *b*. This angle and a similar one on the other side of the beam are connected and braced by means of the cross-piece *c*. Other angle bars are shown at *d* and *e*. At *f* are shown flat bars that are formed to the approximate outline of the cornice, and which are supported by the horizontal angles. The angle bars *e* are

attached directly to the structural beams of the ceiling. This entire construction is enclosed by wire lath to which the ornamental plastering, as shown, is attached.

#### APPLICATION OF THE PLASTER

**114. Running Cornices.**—Upon bases formed as just described, plaster cornices are run. Cornices are run before the finishing coat is put on. Longitudinal strips are attached to the wall, as shown at *e* and *f* in Fig. 50, or at *b*, Fig. 54, on which a templet *a* is run. Sometimes a strip is attached also to the ceiling, but more often the ceiling guide is merely a line.

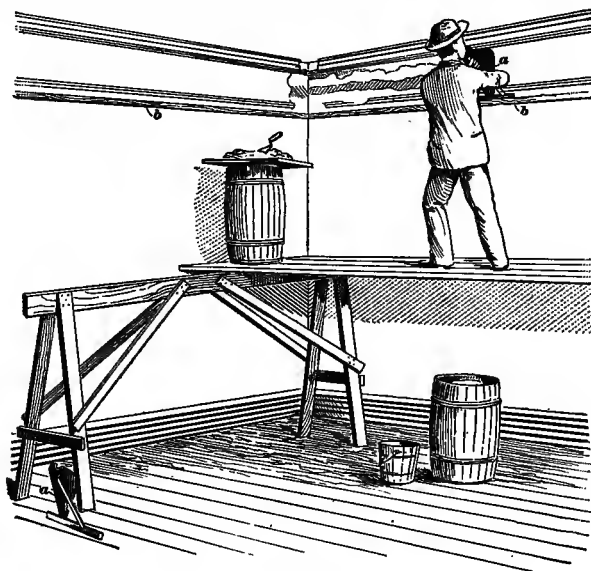

FIG. 54

If coarse stuff is required, it is made to conform to the approximate profile with a muffled templet, that is, by forming a layer of plaster of Paris about  $\frac{1}{8}$  inch in thickness along the edge of the templet; or an extended profile can be cut out of zinc and attached temporarily to the correct templet. The templet is placed in position and is pushed along the angle of

the wall. When the coarse stuff has had time to dry, the surface is coated with gauged stuff and worked over carefully with the correct templet until an exact and perfect finish is obtained.

**115.** Corners and intersections, which cannot be run on the wall, are molded and mitered by hand on the wall, using the tools shown at *o*, *p*, *q*, and *r* in Fig. 45. The plasterer extends the surfaces until they meet at a neat angle. Another way in which the cornice is formed is to run sections of the cornice on a bench, and attach them to the wall by means of a thin mixture of plaster of Paris and water. The internal and external miters are cut on certain sections and set in place.

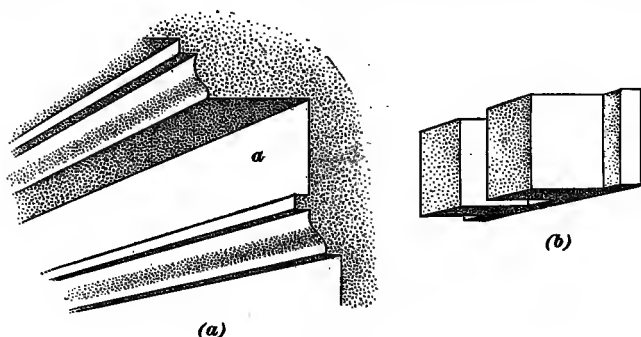

FIG. 55

The joints are then touched up by the plasterer. When this method is followed, the corner is put up first, and the remaining cornice is run to it.

A cornice such as shown in Fig. 51 cannot be run complete on account of the dentil course shown at *d*. The cornice is run without the dentils and the dentils must be cast separately and placed in a recess as shown at *a*, Fig. 55 (*a*). The dentils are cast in lengths (*b*), and stuck in place by means of thin plaster of Paris.

**116. Centerpieces.**—Circular centerpieces consisting of plain moldings are formed in the same manner as run cornices, except that the mold, or templet, is so fastened as to swing around the center of the ornament. Decorated centerpieces



are usually cast in a mold and are stuck on the ceiling with thin liquid plaster of Paris.

**117. Ornamental Ceilings.**—Nearly all kinds of ornamental plastering on ceilings, such as moldings, bas-relief, imitations of foliage, etc., may be formed of plaster of Paris. In paneled ceilings, the ceiling is first marked to show the location of the moldings which are to form the design. The moldings are then cast, or run, and cut by a saw into the required lengths with mitered ends for the points of intersection. All the intersections should be carefully pointed with plaster of Paris, and smoothed with a tool to secure perfect joints in all parts of the work.

In Fig. 56 is shown a portion of an ornamental plaster ceiling in which the design is made up mainly of molded members and leaf-like finials. Very shallow and delicate forms of cast-plaster ornaments are made by pouring the plaster of Paris into a mold, and while the plaster is still soft, pressing a canvas backing into it. This canvas with the plaster ornamentation attached is then applied to the plastered surface, joints being formed at such places as can be easily pointed and concealed.

The liquid plaster which is used to attach cast-plaster ornaments to the ceiling is usually a sufficient fastening for small moldings and ornaments. For large moldings and ornaments, however, it is customary to apply wooden grounds to the ceiling framing before the plastering is done, and the plaster moldings are nailed to these grounds.

**118. Applied Ornamentation.**—A great variety of plaster ornaments, such as corbels, brackets, sculptured panels, ceiling ornaments, friezes, bands, rosettes, and center-pieces, may be obtained from companies making a specialty of such work. For some designs, these ornaments may be made of plaster of Paris, while in other designs the material may be of a special composition made of ground chalk, paper pulp, wood fiber, glue, and other substances. Ornaments of this composition are tougher and lighter than those cast in plaster, and they can be obtained in sizes and shapes which

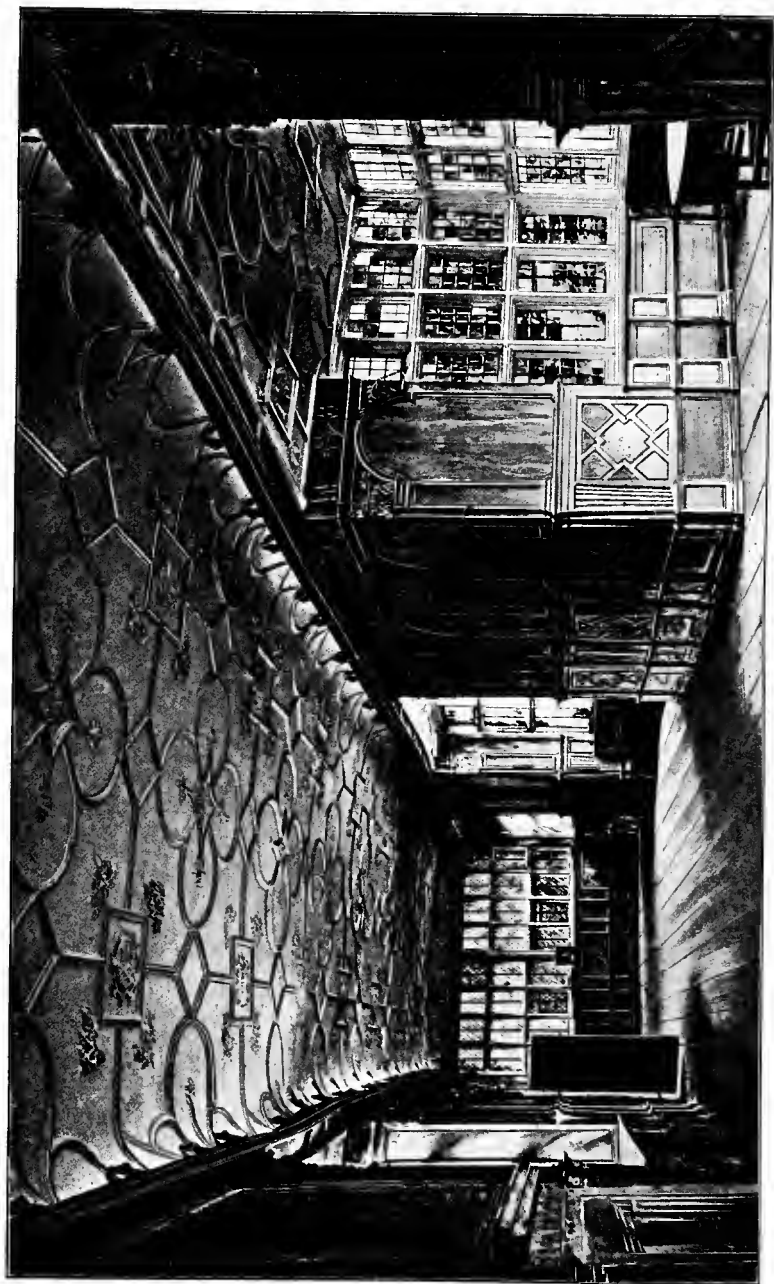
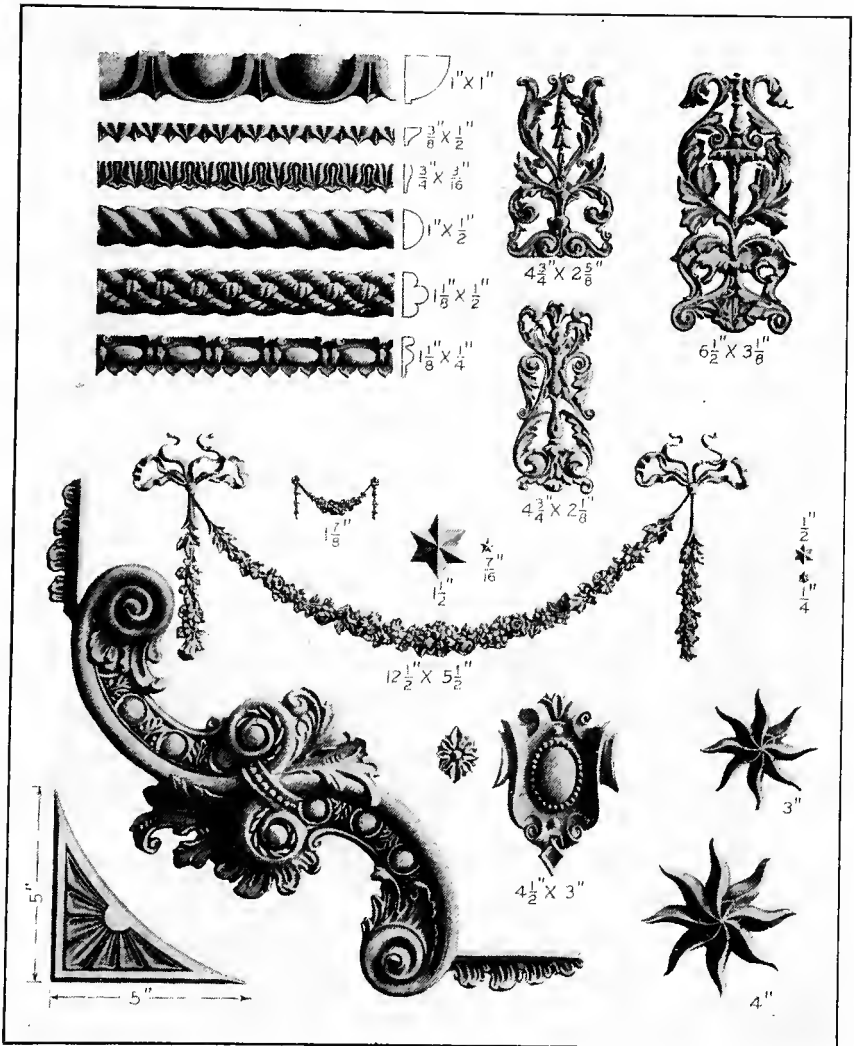

FIG. 56



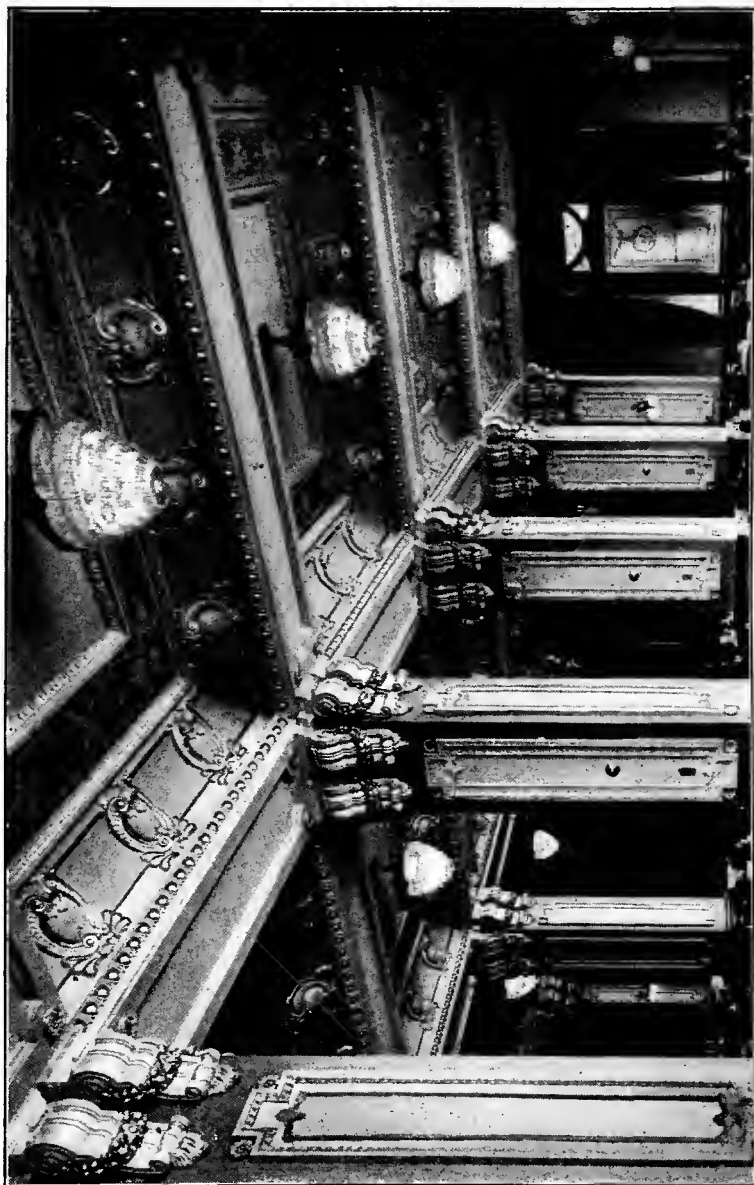

FIG. 58

can be built into practically any design. Fig. 57 shows a number of such ornaments as they are furnished by the manufacturer. The size is marked beside each.

**119.** In Fig. 58 is shown the application of ornamental plastering to a dining-room in a modern hotel. In this work the piers were plastered square on gypsum blocks, while the beams were plastered on metal lath furred out to the required shape. The ornamentation, in the form of panels, rosettes, consoles, moldings, and cartouches were fixed in place with plaster of Paris. This figure illustrates the use of ornamental plastering to represent solid architectural forms, such as columns, piers, brackets, etc. Elaborate architectural effects can thus be produced by the use of ornamental plaster, at a smaller cost than if made of stone or expensive hard woods.

---

## EXTERIOR PLASTERING

---

### STUCCO

---

#### KINDS AND ADVANTAGES

**120. General.**—As has been stated, the term *stucco* is applied to plaster used on the exterior surfaces of walls. Stucco should be composed of materials that will stand exposure to heat, cold, and water, and thus form a durable outer covering for the building.

**121.** Three kinds of stucco are distinguished by the different materials that enter into their composition. *Lime stucco* consists principally of lime, sand, and aggregates. *Portland cement stucco* consists of Portland cement, sand, lime, and aggregates. *Magnesite stucco* consists of magnesium carbonate, or magnesite, mixed with a liquid chemical, and when applied to wall it forms a hard, weather-proof stucco.

**122. Advantages of Stucco.**—Stucco can be applied upon masonry walls and wooden walls in the same manner as

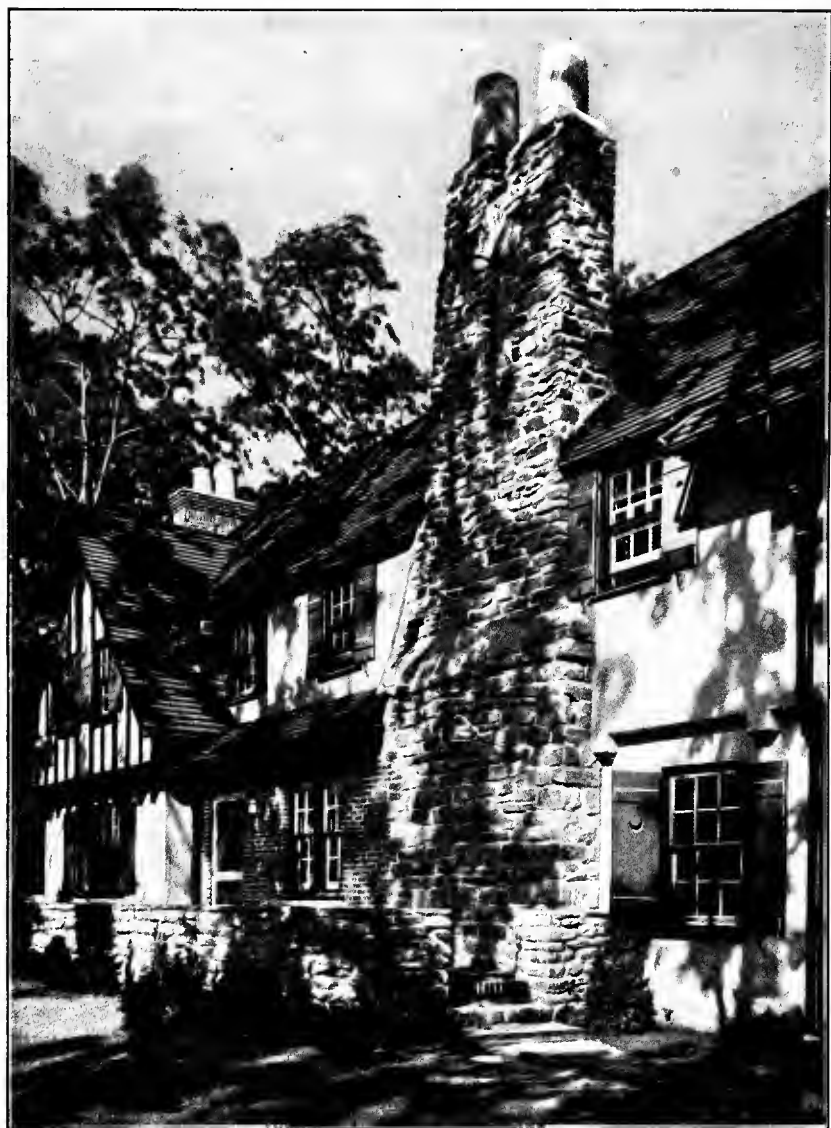

FIG. 59

interior plastering. It is strong, weatherproof, and fire-resisting to a large degree. The surfaces can be treated to imitate solid stone masonry and permit the execution of architectural effects which, if obtained by the use of stone, would be very expensive. Stucco can be finished as a plain coating or in tints and surface textures as desired.

The walls of an entire building may be coated, or the stucco may be applied to portions of the wall while other parts may be of brick, stone, or wood, as shown in Fig. 59. A stucco coating can be applied to old wooden or masonry buildings, renovating the building and greatly improving its appearance.

#### PREPARATORY WORK FOR STUCCO

**123. General Requirements.**—Before any stucco is applied all roof gutters should be set, and conductors, hangers, and all other fixed supports and fasteners should be in place, so that there will be no break made in the surface of the stucco after it is once completed. All of the outside finished trim should be placed at the correct distance from the studding, or furring, to show its proper projection in relation to the finished surface of the stucco. Wall copings, balustrade rails, chimney caps, cornices, and similar work, whether made of wood, stone, or stucco, should be designed with ample drips, grooves, or lips, as at *a* in Fig. 60, or at *a* in Fig. 61, to keep water from running down on the face of the stucco.

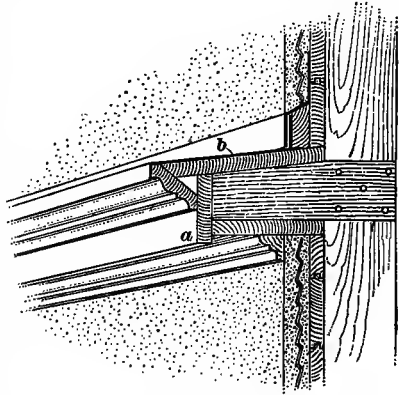

FIG. 60

**124. Flashings.**—Suitable flashings should be provided over all door and window openings, or wherever any projecting wood trim occurs, as at *b* in Fig. 60, and at *a* in Fig. 62, to

prevent water from entering the joints between the wood and the stucco. With copings of stone, cast cement, or brick, with mortar joints, continuous flashing should extend across the wall under the coping, and should project beyond to form an inconspicuous lip over the edge of the stucco. Similar continuous flashing should be so installed as to insure absolute protection against leakage back of the stucco.

Special attention should be given to the design of gutters and conductors at the returns of porch roofs, where it is possible that an overflow would produce unsightly discolorations of the stucco.

At the intersections of sloping roof with stuccoed wall surfaces, the roof courses should first be flashed separately, and an additional strip of flashing placed over the roof flashing, extending 4 inches up on the wall surface. The stucco surface should then extend down to within 2 inches of the roof surface. Care should be taken to see that the water is in all cases led away from the stucco surfaces.

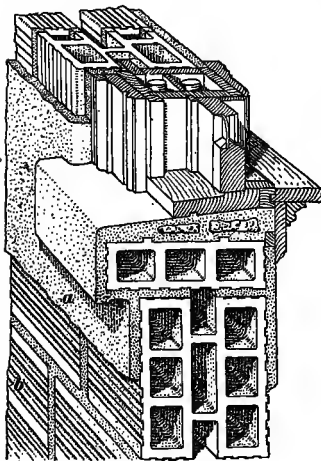

Fig. 61

### 125. New Masonry Surfaces.—

New surfaces of stone, brick, hollow building-tile, or concrete, should have ample roughness to assure a strong bond and key between the stucco and the surface. When the walls are of brick, the joints should be not less than  $\frac{1}{4}$  inch thick. The joints in new walls must be left rough, and not struck smooth. Hollow building-tile used for walls usually are scored, or grooved, to furnish a key for the stucco, as shown at *b* in Fig. 61.

**126. Existing Masonry Surfaces.**—When a masonry wall that is to be stuccoed has been in place for some time, as in the case of old buildings, the exposed surfaces should have all dirt, dust, or other foreign matter removed by



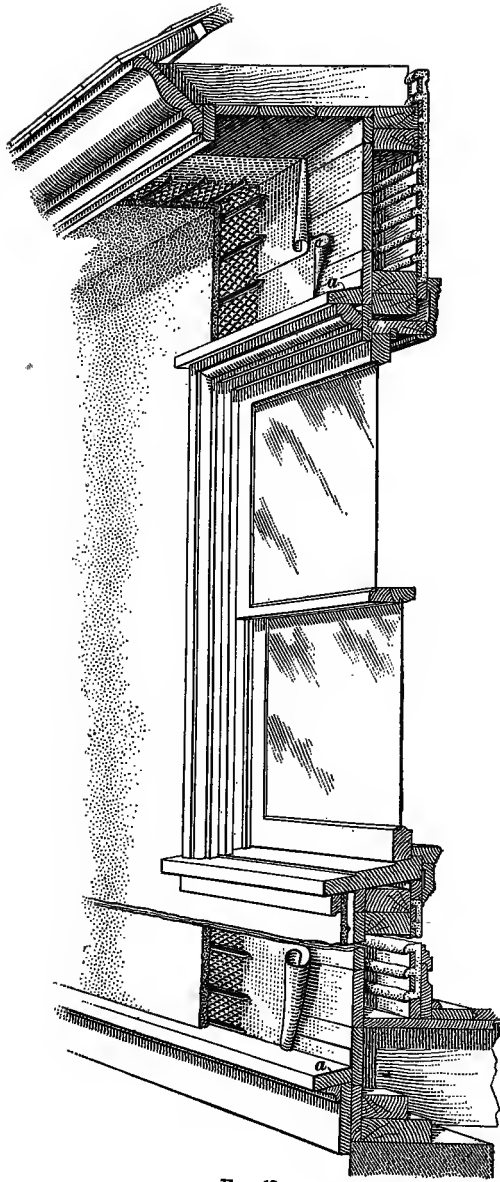

FIG. 62

means of a wire brush, or broom. All traces of moss or other vegetable growth must be removed, so as to present a clean, absorptive, surface. All loose, friable, or soft, mortar should be removed from the joints, to a depth of not less than  $\frac{1}{2}$  inch. In case the surface has been painted, it will be necessary to remove the paint by means of a lye solution, or by a sharp tool which will hack away the surface. When the surface cannot be brought to such a condition that stucco will adhere firmly, furring and lathing must be applied.

**127. Furring on Masonry Walls.**—When it is necessary to furr existing walls for stucco, wood or metal furring-strips should be placed vertically at 12 inch centers. Wooden plugs may be driven into the joints of the wall, to which the furring is nailed. When the furring forms part of the lath to be used, separate furring is unnecessary.

**128. Sheathed Surfaces.**—The frame of a wooden building should be rigidly constructed and well braced, so as to prevent cracking of the stucco from vibration, such as would occur during a violent windstorm. At least one course of horizontal bridging, or bracing, should be placed between the studs in each story height.

Sheathing boards should be not less than 6 inches nor more than 8 inches wide, dressed on both sides to a uniform thickness and nailed to each stud. Sheathing boards placed diagonally on the studding have been assumed to add greatly to the strength and rigidity of the building. Sheathing boards, however, laid horizontally across the wall studs, and fastened with at least two eight-penny nails at each stud, have been shown by tests at the United States Bureau of Standards, to produce satisfactory results with respect to the stucco itself.

**129. Sheathing Paper.**—Sheathing paper should be laid over the sheathing boards in horizontal layers, beginning at the bottom. Each strip should lap over the one below at least 2 inches.

**130. Application of Wooden Lath Over Sheathing.** When stucco is to be applied to a frame building, the studs

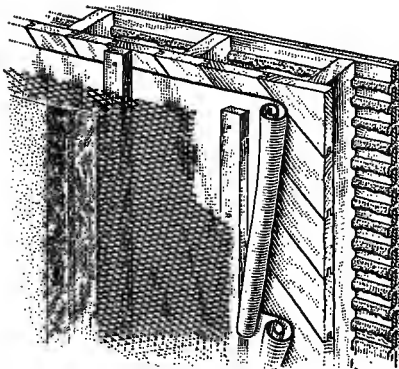

(a)

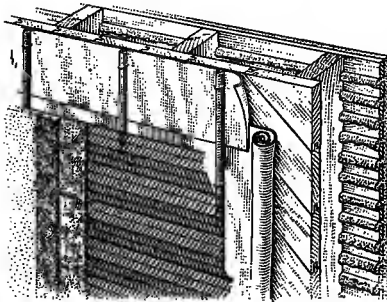

(b)

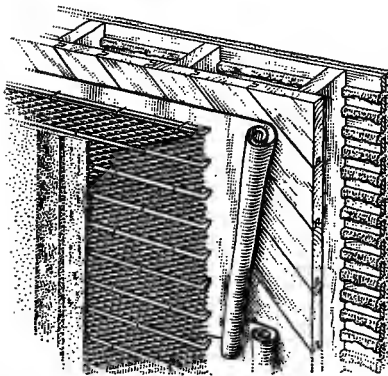

(c)

FIG. 63

are sheathed and papered as just described. Over the paper, furring strips should be nailed about 12 inches on centers. The furring strips are placed vertically and the lath applied horizontally as for interior plastering. The lath should be separated sufficiently to provide a good key, and the joints broken as in interior lathing. Strips of metal lath should be bent around the corners and openings, which will tend to prevent cracks that might occur at these positions.

**131. Application of Metal Lath Over Sheathing.**—Metal lath may be applied over sheathing in any of three ways. The first is upon wood furring placed vertically 12 inches on centers and nailed securely to the sheathing, as in Fig. 63 (a). The second is upon metal furring as in (b), applied to the sheathing with staples. A third way is to use a combined lath and furring as in (c). The ribs should be stapled to the sheathing so that there will be a space for a key back of the lath.

**132.** Plaster boards are sometimes used as a base for stucco. They are applied directly over the sheathing, to which they are nailed. The paper is omitted in this case. A type of board should be used to which the stucco will adhere readily and which will not deteriorate under the weather. The usual size of such boards is 32 by 36 inches. Twelve broad-headed nails should be used for each sheet of this size. The vertical joints should be broken in every course.

---

#### MATERIALS FOR STUCCO MORTAR

**133. Essential Materials.**—The basic material comprising stucco may be either lime, Portland cement, or magnesite cement. What is known as *lime stucco* may or may not have a small amount of Portland cement added to it, and what is known as Portland cement stucco may or may not have a small amount of lime added to it. Magnesite cement cannot be mixed with either lime or Portland cement. The other ingredients, in the case of either lime stucco or Portland cement stucco, are fine aggregate, water, colored aggregate, mortar colors, and hair, or fiber, for the purpose of improving the quality of the stucco, or giving it a more pleasing texture or color. To vary the finish, colored aggregates may be added to magnesite stucco.

**134. Portland Cement.**—Any standard brand of Portland cement may be used for stucco. If a gray, or mouse-colored, stucco is desired, the ordinary gray Portland cement is used. If, however, a white stucco is desired, white Portland cements that are in the market can be used with white sand or marble dust.

If cement is used to harden lime in stucco, the amount of cement used should be about 20 per cent. of the amount of lime in weight.

**135. Fine Aggregate.**—Fine aggregate for stucco may consist of sand, or screenings from crushed stone or gravel. It should be well graded from fine to coarse particles, passing through, when dry, a screen having eight meshes to the linear

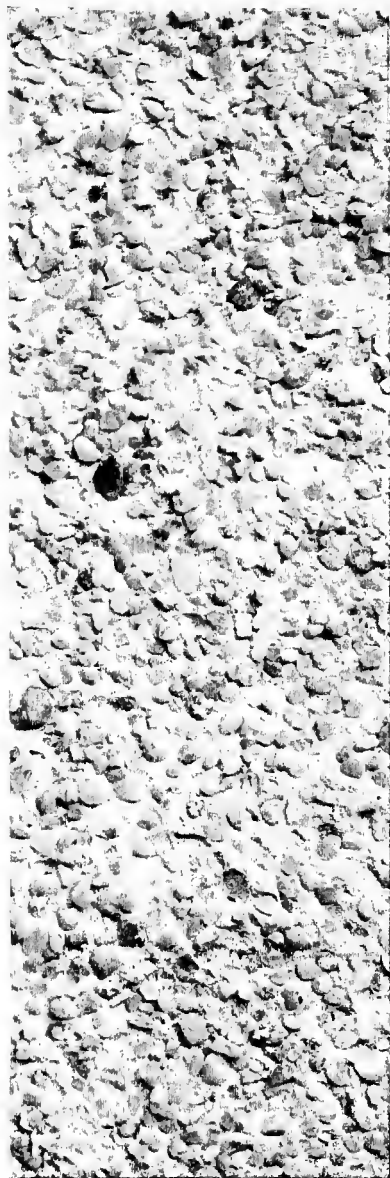

FIG. 64



ILL. T. 31F § 38 FIG. 65



inch. Fine aggregate should not contain organic matter, nor more than 7 per cent., by volume, of clay or loam.

**136. Water.**—The water used for stucco should be clean and free from oil, acid, strong alkalis, or vegetable matter, as such substances affect the strength of the stucco, as well as the rate of setting.

**137. Lime.**—Freshly burned quicklime may be used for lime stucco. The lime must be slaked properly, and, preferably, should be run through a fine sieve in order to remove any unslaked particles. Hydrated lime also may be used for lime stucco, and should be used whenever a good quality of freshly burned quicklime cannot be obtained.

**138. Hydrated Lime.**—For the purpose of making cement stucco more waterproof, a small amount of hydrated lime may be added to Portland cement stucco. This material gives the stucco a lighter color when it is used in the finishing coat, and causes the stucco to work smoother. The volume of the hydrated lime should not exceed 20 per cent. of the volume of the Portland cement used in the mixture.

**139. Colored Aggregates.**—The principal materials used for giving the finishing coat of stucco a more pleasing color or texture are sand, colored pebbles, crushed granite, marble, sandstone, quartz, and gravel. These materials occur in a variety of pleasing colors, and a mixture of two or more of them is used to give a variegated appearance, as indicated in Figs. 64 and 65.

**140. Mortar Colors.**—Commercial preparations for coloring stucco mortar may be mixed in the finishing coat of stucco to give practically any desired color, or tone. These preparations are known as *pigments*, or *mortar colors*. As there is a possibility of reducing the quality of the stucco by the addition of too much coloring matter, the best authorities limit the amount to not more than 10 per cent. of the weight of the basis material. Only mineral colors should be used, and preference should be given to strong colors, of which

only small quantities need be used, rather than to the weaker colors, of which a larger amount is required to give the desired tone.

**141. Hair or Fiber.**—Hair or fiber is sometimes added to the first coat of stucco on wood or metal lath to assist in holding the stucco together until it has set. It is not necessary when the stucco is applied to masonry surfaces.

---

#### PREPARATION OF STUCCO MORTAR

**142. Measuring.**—The materials used for stucco mortar should be carefully measured, in order that uniform proportions may be secured. Uniformity in proportions is necessary for uniformity of quality and appearance in the finished stucco. This is particularly true when mortar colors are used for tinted effects.

A sack of Portland cement contains 94 pounds, and is assumed to occupy 1 cubic foot of space, while 1 cubic foot of hydrated lime weighs 40 pounds. The weight of a cubic foot of sand will vary from 80 to 120 pounds, according to whether it is fine, or coarse, or well graded. Lime paste is measured by the cubic foot, after being thoroughly slaked.

---

#### PROPORTIONS OF MATERIALS

**143. Lime Stucco.**—It is considered desirable with lime stucco to have the scratch coat the richest, and each succeeding coat leaner. An average of the quantities to use, based on hydrated lime, would be 10 cubic feet of lime to 27 cubic feet of sand for the scratch coat on masonry, 11 to 27 for the scratch coat on wood lath, and 12 to 27 for the scratch coat on metal lath. For second coats, 1 cubic foot less of lime should be used on each 27 cubic feet of sand. Where cement is to be used for accelerating the hardening, 1 cubic foot makes a good quantity to add to each of the above measurements.

**144. Cement Stucco.**—Each of the coats of Portland cement stucco should be mixed in the proportions of about



1 part, by volume, of Portland cement to 3 parts of sand, or fine aggregate, the exact proportion depending upon the nature of the sand, and whether two-coat, or three-coat work is being applied. It is well to increase the amount of the sand by about  $\frac{1}{2}$  part for each successive coat. Hydrated lime may be added to the mixture, but not to exceed 20 per cent., by volume, of the cement. The proportions of the finishing coat will vary somewhat when special finishes are desired. When mortar colors or special waterproofing compounds are added, it is usually advisable to omit the hydrated lime.

---

#### MIXING

**145. Lime Stucco.**—The ingredients of the mortar should be mixed with the minimum amount of water to obtain the required consistency. When cement is added, the mixing should continue until the lime and the cement are evenly distributed, and the mass is uniform in color.

**146. Cement Stucco.**—The ingredients of the cement stucco should be mixed dry until a uniform color is obtained. Sufficient water should be added to produce, after thorough mixing, a mortar that is sufficiently plastic to spread evenly under the trowel, and yet be stiff enough to hold its keys on the wall or to bond to the under coats.

Mixing by machine is desirable on all work and particularly on large jobs. A batch mixer should be used, and the mixing continued for at least two minutes after all the materials, including water, are in the mixer drum. No fresh material should be introduced into the mixer until all the preceding batch has been discharged. When hand mixing is employed, the mixing should be done in a watertight box, and sufficient turnings should be given the materials, both when dry and when wet, to secure uniform color and consistency.

**147. Retempering.**—Mortar that has partially hardened should not be retempered, that is, remixed with additional dry materials or water. If this is done, the strength of the stucco will be greatly impaired, the color will vary from that

of the rest of the work, and the stucco is apt to be soft and porous.

No more Portland cement stucco should be mixed at one time than can be used within 1 hour after water has been added to the dry materials. With lime stucco the time may be extended, if no cement has been added. Any mortar which has begun to harden should be discarded.

---

#### APPLYING THE STUCCO

**148. Spraying.**—Immediately before applying the first coat of stucco, the base, if of brick or porous masonry, should be sprayed, or wet down, but not completely saturated with water. This is more necessary in hot weather than on cool, damp days. This prevents too much water from being taken away from the lime stucco, and also prevents cement stucco from setting too quickly. The masonry surface should, however, absorb a small amount of moisture from the stucco, which is the reason that the background should not be saturated.

Wood lath should be sprayed, but not thoroughly soaked, just before applying lime stucco. Before applying cement stucco the lath should be thoroughly wetted. Metal lath, stucco boards, sheathing lath, and similar preparations need no spraying before applying the stucco.

**149. Names of Coats.**—Stucco usually is applied in three coats on wood, or metal, lath, and in two coats on masonry backgrounds. The finish will often constitute a separate application which is not usually considered as a coat. The first is known as a *scratch coat*, or when applied to masonry, as the *rendering coat*. The second is known as the *intermediate*, or *brown coat*. In two-coat work this coat may also become the finishing coat if it is only floated and not given any of the surfaces later described. The third coat, when applied, is known as the *finishing*, or *final*, coat.

**150.** Without allowing the plaster to dry out on the edge, the application of the stucco should be carried on continuously

in one general direction. This applies particularly to the quick-setting stuccos. When it is impossible to work the full width of the wall at one time, the joint should be at some natural division of the surface, such as a door or window, at a belt course, or behind a rain conductor.

**151. Scratch Coat.**—The first, or scratch, coat of stucco should cover the base on which it is applied, and should be troweled well to insure a good bond with the base. On masonry walls, this coat should be sufficiently thick to fill all crevices, and cover the wall with a thickness of at least  $\frac{1}{4}$  inch. On wood lath, the minimum thickness of the plaster over the lath should be  $\frac{3}{8}$  inch, while on metal lath, a thickness of  $\frac{1}{4}$  inch is sufficient. Before the scratch coat has set, it should be heavily cross-scratched with a saw-toothed metal comb, or other suitable device, to furnish a good mechanical key for the intermediate coat.

**152. Intermediate Coat.**—The intermediate, or brown, coat should be applied, in the case of lime stucco, after the first coat has thoroughly hardened, and when cement stucco is used, on the day following the application of the scratch coat. Screeds should be formed in the brown coat at 5-foot intervals to assist in bringing the surface to a true and level plane.

When the intermediate coat has sufficiently hardened, it should be floated with a wood float and firmly and evenly cross-scratched, or scored, to form a key for the finishing coat. On the following day and until the finishing coat is applied, the surface of cement stucco should be sprayed at frequent intervals, to keep it from drying out. This is not necessary with lime stucco, and is more necessary with cement stucco in warm weather than in cool weather.

**153. Finishing Coat.**—The third, or finishing, coat, in the case of lime stucco is applied after the intermediate coat is hard and dry; in the case of cement stucco, it is applied a week or more after the intermediate coat. This interval is necessary to allow the intermediate coat to obtain its initial shrinkage and to approach its final condition of strength and

hardness before being covered with the finishing coat. The finishing coat will vary from  $\frac{1}{8}$  inch to  $\frac{3}{8}$  inch in thickness, depending on the finish desired.

**154. Thickness of the Stucco.**—On masonry walls the total thickness of the stucco for two-coat work, should not be less than  $\frac{5}{8}$  inch, and for three-coat work not less than  $\frac{7}{8}$  inch. On stucco boards, the thickness should be from  $\frac{7}{8}$  to 1 inch. On wood lath, the finishing coat should bring the stucco at least  $\frac{3}{4}$  inch over the lath, and on metal lath, to at least 1 inch outside the furring strips which support the lath. These thicknesses are determined by the thicknesses of the grounds. A variation in the total thickness of the stucco will occur on different parts of the wall, owing to surface irregularities which are brought to true planes by screeding.

On masonry walls, and on stucco-boards, the scratch coat and the intermediate coat are often applied in close succession, practically at one operation, but this is not desirable when the total thickness of the coat exceeds  $\frac{1}{2}$  inch, as coats of that thickness have a tendency to bag or slip, producing an uneven and weak body for the finishing coat.

**155. Drying Out.**—The finishing coat should not be allowed to dry out rapidly. The surface of cement stucco, therefore, should be sprinkled frequently. Wet burlap, or similar materials, may be hung over the surface of cement stucco to keep it moist until it has set properly. Sprinkling is not necessary with lime stucco.

**156. Freezing.**—Neither lime nor Portland cement should be applied when the temperature is below the freezing point, or when it is apt to go below the freezing point within a few hours.

**157. Back-Plastered Stucco Walls.**—Stucco is sometimes applied to metal lath on studding without sheathing or papering. In this method, a coating of stucco is applied to the back of the lath as well as to the face, from which fact the method is called *back-plastering*. A section of a back-plastered wall is shown in Fig. 66. As the sheathing is

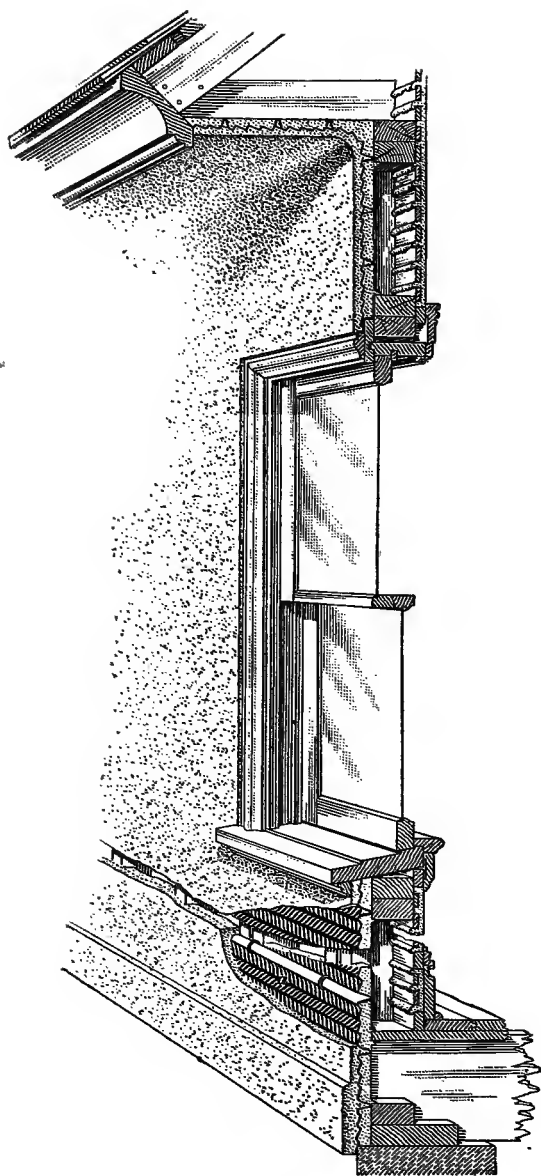

FIG. 66

omitted, the wooden framing of the structure must be particularly well braced.

**158. Lathing for Back-Plastered Walls.**—The lathing used for back-plastering is a combination lath and furring and the furring is applied across the studs. This assures an even thickness of plaster in front of the studs, as well as between them. Separate metal furring is sometimes used with plain metal lath stapled over it and into the wooden studs.

---

#### STUCCO FINISHES

**159.** The appearance of a stuccoed building depends largely on the finish of the stucco surface. Stucco finishes depend on texture and color, or on both in combination. Texture effects are due to the form of the surface, while color effects depend on the colors of the various ingredients used. As the color of the ingredients will be apparent in the various texture finishes, desired effects are generally obtained by a combination of texture and color.

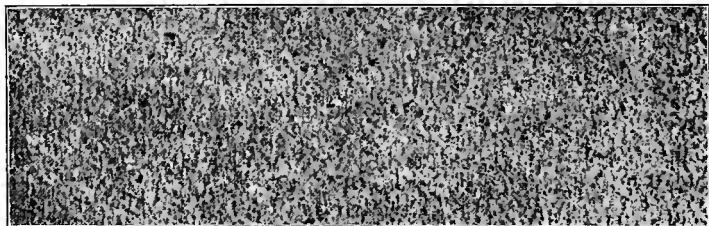

FIG. 67

**160. Texture Effects.**—The principal surface finishes which depend on texture for their effect are *smooth-troweled*, *stippled*, *sand-floated*, *sand-sprayed*, *rough-cast*, or *spatter-dash*, and *pebble-dash*. These finishes are shown in Figs. 67 to 72, inclusive, which are made from photographs furnished by the Atlas Portland Cement Company.

**161. Smooth - Troweled Finish.**—In the smooth-troweled finish, Fig. 67, the finishing coat is troweled smooth with a metal trowel. The surface should be rubbed as little

as possible, as continued rubbing or troweling is apt to bring an excess of cement to the surface. Excessive rubbing results also in fine hair cracks, which are readily discernible and are

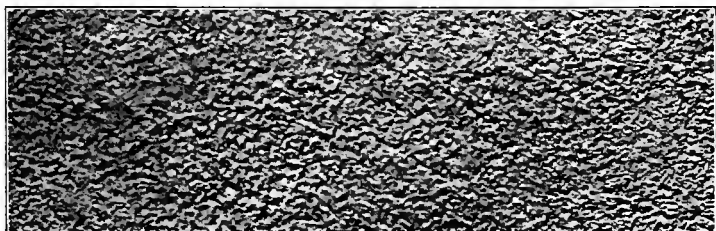

FIG. 68

objectionable in appearance. This finish is used sometimes in small panels, but is not satisfactory for large areas. In Fig. 59 are shown wall surfaces having smooth-troweled finishes.

**162. Stippled Finish.**—After the finishing coat has been brought to a smooth surface by troweling, it may be lightly patted with a brush of broom straw, to give an even, stippled, surface. This must be done before the cement has attained its initial set. A panel in this finish is shown in Fig. 68.

**163. Sand-Floated Finish.**—After the finishing coat has been brought to a smooth, even, surface, a little sand is sprinkled over the surface, and the surface rubbed with a

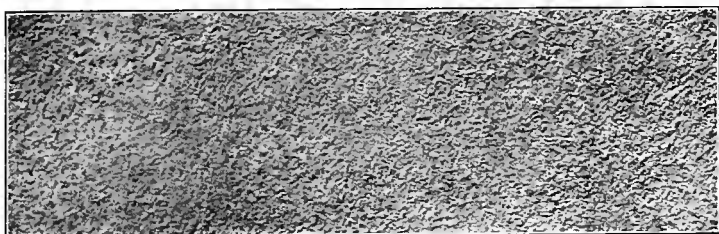

FIG. 69

wooden float, the float being worked with a circular motion. This floating should be done when the mortar has partially hardened. A panel with this finish is shown in Fig. 69.

**164. Sand-Sprayed Finish.**—When the finishing coat has been brought to an even surface, as in the smooth-troweled finish, it may be sprayed by dashing a creamy mixture of

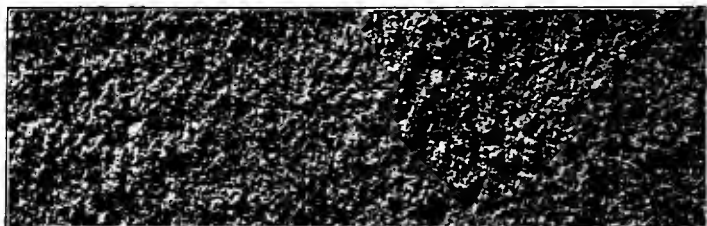

FIG. 70

equal parts of Portland cement and sand against the surface by means of a wide, long-fibered brush, similar to a whisk-broom. The coating should be thrown forcibly against the surface to be finished, and should be applied while the finishing coat is still moist, before it has obtained its early hardening, that is, within 3 to 5 hours after the application of the finishing coat. The mixture should be made up fresh every 30 minutes and kept well stirred. A panel in this finish is shown in Fig. 70.

**165. Rough-Cast, or Spatter-Dash, Finish.**—To produce the rough-cast, or spatter-dash, finish, shown in Fig. 71, the finishing coat is first brought to a smooth, even

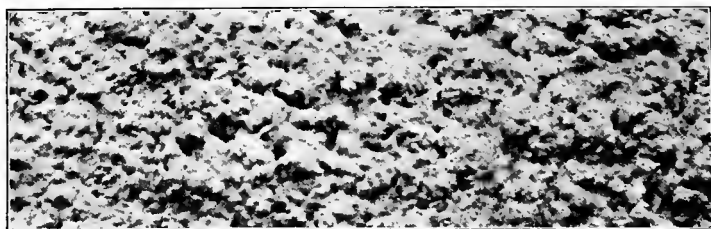

FIG. 71

surface by means of a wooden float. Before the surface has finally hardened, it is coated uniformly with a mixture in the proportions of 1 sack of Portland cement to 3 cubic feet of



sand or finely crushed stone, with enough water to make a stiff mixture. This is thrown forcibly against the surface so as to produce a rough surface that will appear to be of uniform texture. Special care must be taken with this finish to prevent too rapid drying out. To prevent this, it is necessary to wet the stucco at intervals after it has hardened sufficiently to prevent its being injured by the application of water.

**166. Pebble-Dash Finish.**—To produce the pebble-dash finish, shown in Fig. 72, the finishing coat is brought to a

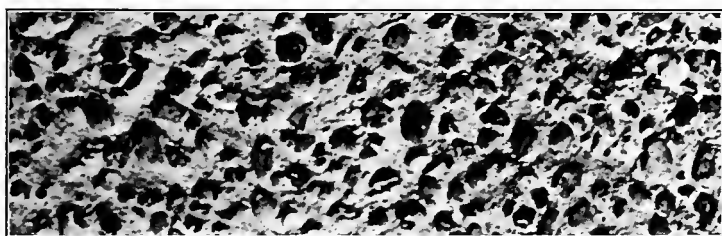

FIG. 72

smooth surface, as in the finishes just mentioned. Before the stucco begins to harden, clean, round pebbles, or such material as may be selected,  $\frac{1}{4}$  inch or larger, and previously wetted, are thrown forcibly against the wall so as to embed them in the soft mortar. The pebbles should be evenly distributed over the surface of the finishing coat, and they may be pressed back into the stucco by means of a clean, wooden trowel, but the surface should not be rubbed after the pebbles are embedded. This finish is sometimes known as the *applied-aggregate* finish.

---

#### COLOR EFFECTS

**167.** Color effects in stucco may be secured by a selection of the ingredients of the finishing coat of stucco, or by the application of surface coatings. Aggregates may be obtained in a great variety of colors, and these colors may be produced in the surface of the stucco by exposing the aggregates in the surface of the walls.

Ordinary lime stucco will give a pleasing whitish-gray or light-buff color, depending on the color of the sand. Stucco composed of ordinary Portland cement and common sand will have a grayish, or mouse color, different brands of cement causing a slight variation in the color of the finish. Sand occurs in various colors, such as white, yellow, red, and brown, which produce corresponding effects on the color of the stucco. Where a pure white effect is desired, it can be obtained by the use of lime, or of white cement and white sand. Hydrated lime in cement stucco will give the stucco a lighter tone. The color of the stucco may be varied further by adding pigments, or mortar colors, to the finishing coat of stucco. Should the finished surface not have the desired color, it may be coated with a wash, or paint, to obtain a more satisfactory tone.

**168. Exposed-Aggregate Finish.**—There are two methods of producing the exposed-aggregate finish. In the first, known as the *integral* method, the aggregate is mixed with the mortar of the finishing coat. In the second, known as the *cast-on* method, the aggregate, which may be pebbles, crushed stone, or gravel, is applied to the surface of the finishing coat in the same manner as already described for pebble-dash finish.

In the integral method, the finishing coat, consisting of Portland cement, sand, and the desired aggregate, is brought to a smooth surface by means of a wooden float. When the cement stucco has hardened sufficiently, but before it has obtained its final hardness, the surface is scrubbed with a stiff brush and water, to remove the thin film of cement which covers the aggregate. When the cement cannot be removed by this scrubbing, a solution of 1 part of hydrochloric acid in 4 parts of water may be used. After the aggregate particles are uniformly exposed by scrubbing, all traces of the acid may be removed by spraying with water from a hose.

In Fig. 64 is shown a panel in which the color effect was produced by the use of a finishing coat composed of 1 part white Portland cement, 2 parts white sand and  $\frac{1}{10}$  part hydrated lime. When the surface had been made smooth,

yellow gravel was thrown on the surface and lightly pressed in. In Fig. 65, a finishing coat consisting of 1 part white Portland cement and 2 parts white sand was used, but the aggregate consisted of 1 part yellow gravel,  $\frac{1}{10}$  part green marble, and  $\frac{1}{10}$  part black marble.

As a great variety of materials are available for use by these methods, the architect can secure practically any surface effects. An advantage of the exposed aggregate finish is that the colors, being those of the natural stone, are reasonably sure to be permanent. The advantage, obtained in the case of colors and stones, is obtained with natural sands.

**169. Pigments and Mortar Colors.**—When it is desired that any of the finishes mentioned be made with colored mortar, certain mineral mortar colors, or pigments, may be added to the finishing coat of stucco. When using these materials, it is advisable to use white cement and white sand, or, otherwise, the color of the pigments would be affected by the gray of the cement and by the color of the sand.

**170. Coatings on Stucco Surfaces.**—Coatings for new stucco surfaces are used for the purpose of securing a suitable color, a uniform appearance, and a more impervious surface. The surface to which the coating is to be applied should be free from dust, dirt, and loose particles, in order that the coating may adhere well. The coating may consist of a thin mixture of equal parts of Portland cement and sand, to which may be added hydrated lime, or other materials to produce the desired color.

**171.** Coatings containing various colored pigments may be obtained for covering the finished stucco surface. After application to the surface, the liquids either evaporate or are absorbed by the stucco, leaving the pigment attached to the surface. These coatings are applied by means of a brush, or with a hose having a spray nozzle, at any time after the finishing coat has hardened. These coatings may be used to change the color of the stucco after it has been in place for a time, and as they close the pores of the stucco, they have a certain amount of waterproofing value.

## WATERPROOFING OF STUCCO

**172. Need and Methods.**—Stucco must be impervious to moisture, which would cause disintegration through rusting of the metal lath or nails, and through the action of frost, should the stucco become saturated. Should the moisture reach the wood frame, there is a possibility of swelling as well as decay. When the moisture extends through to the interior of the wall, the dampness makes an unsanitary dwelling. A stucco wall that absorbs moisture becomes discolored and apt to show efflorescence.

**173.** Moisture will not readily penetrate a dense wall, and one of the best methods of making a stucco wall impervious to moisture is to grade and mix the material in such a way that the voids and pores in the stucco are reduced to a minimum. Where the nature of the materials is such that an impervious wall cannot be formed in this manner, the stucco may be waterproofed by either of two methods, one known as the *integral method*, and the other known as the *applied-coating method*.

**174. Integral Method.**—One method of integral waterproofing is to add 1 pound of tallow to each bushel of lime in the slaking bed before it is slaked. This is an effective integral method of waterproofing for lime stucco. The heat generated during the slaking melts the tallow. The tallow turns to soap and melts, making with the lime an insoluble material which is impervious to water. In the case of cement stucco a small percentage of hydrated lime added to mortar is an effective integral method of waterproofing. The lime, or compounds, fill the voids in the stucco, and form chemical combinations with the Portland cement, the result being that absorption of water is prevented.

Other integral methods for waterproofing for both lime and cement stucco are being offered by manufacturers, sometimes being combined as a coloring and waterproofing material, although practically colorless waterproofing may be obtained.

**175. Applied Method.**—In the applied coating method, the waterproofing preparations, known as exterior waterproof-

ings, brick and cement coatings, damp-proofings, etc., are applied by means of a brush to the surface of the finished stucco, two or more coats being required usually to insure good results.

#### MAGNESITE STUCCO

**176. Magnesite stucco** contains the mineral magnesite as the principal ingredient. When mixed with a liquid such as chloride of magnesium, magnesite forms a dense, hard, rock-like, substance. Before adding the liquid, sand, asbestos, fine aggregate, and mineral colors are added to the magnesite. The liquid is then added to form a plastic material for use as stucco which may be used wherever lime or Portland cement stucco can be used.

Some of the well-known brands of magnesite stucco are *Elastica*, *Kellastone*, *Kragstone*, *Magnesite*, and *Rocbond*. The exact proportions of materials in these stuccos are not stated by the manufacturers, who supply the materials ready to mix and apply.

**177. Advantages.**—An important feature of magnesite stucco is that the materials will not freeze at any temperature as low as 20° below zero, and so the stucco may be applied at practically any time of the year. The materials have a very high resistance to fire, and they insulate the building against heat and cold. When properly applied, a hard, dense, surface is obtained, making the building durable and dampproof.

**178.** Practically any of the finishes described for lime or Portland cement stucco may be obtained with magnesite stucco. In some cases the manufacturer is prepared to furnish the material of any color desired. At other times, the plasterer must mix in the color when the stucco is applied.

Magnesite stucco may be applied to surfaces of brick, hollow tile, cement blocks, concrete, or to wood, or metal, lath, stucco board, or similar bases.

**179. Preparation of Surfaces.**—The same care necessary in preparing the base for Portland cement stucco should

be followed when magnesite stucco is to be applied. When wood lath is used, the joints between the lath should be kept thin, about  $\frac{1}{8}$  inch being recommended. At all corners and openings, metal lath should be applied to aid in preventing cracks.

**180.** When masonry walls are to be covered<sup>d</sup> with magnesite stucco, care must be taken to insure a clean roughened surface. When a satisfactory surface cannot be obtained, as may occur with an old brick wall which has been painted, or disfigured by oil or smoke, the wall should be covered with coarse-mesh, metal lath, securely attached to the wall. In some cases, it may be advisable to drive large flat-headed nails into the mortar joints at frequent intervals, leaving the heads projecting. The stucco hardens around these nail heads and is anchored to the brickwork.

**181.** Masonry walls must be dry and free from frost when magnesite stucco is applied. While the materials in the stucco will not readily freeze, any moisture or frost in the walls will prevent the stucco from adhering firmly.

**182. Application of the Stucco.**—Magnesite stucco usually is shipped ready to mix with the liquid furnished. In some cases, sand or other fine aggregate may be added. The materials should be mixed only as required, as retempering is not possible after the materials begin to set.

**183.** Magnesite stucco usually is applied in two coats; the first, or *scratch coat*, and the second, or *finish coat*. When an additional finish of crushed aggregate is added, this sometimes is called a *dash coat*.

**184. First Coat.**—Before any stucco is applied, it is advisable, usually, to brush masonry surfaces with the mixing liquid. The first, or scratch, coat usually contains, besides the magnesite and mixing liquid, certain qualities of washed and graded sand. There may be also added long-fibered asbestos to serve as a binder, and granulated cork for insulation and filler. This coat is generally  $\frac{1}{4}$  to  $\frac{3}{8}$  inch thick.

**185. Second Coat.**—The second, or finish, coat is composed of practically the same materials as the first coat, with the exception that shorter-fibered asbestos may be used, and mineral colors added to give the desired tone to the stucco. The surface of the first coat may be brushed with the mixing liquid before applying the second coat, as this will tend to cause a firmer bond between the two coats. The second coat generally is  $\frac{1}{4}$  to  $\frac{3}{8}$  inch thick, and any irregularities in the wall surface must be taken up in this coat. The total thickness of the stucco should never be less than  $\frac{1}{2}$  inch in the thinnest part, and a thickness of  $\frac{3}{4}$  to 1 inch is preferable.

**186. Surface Effects.**—Surface effects in texture and color similar to those described for Portland cement stucco may be obtained with magnesite stucco by using similar methods.

---

## MISCELLANEOUS

---

### WHITEWASHING

**187. Whitewash,** a lime preparation used for coating masonry, concrete, and wood surfaces, either on exteriors, or in basements, cellars, and underground rooms, and passages, is useful for preventing decay in wood, and valuable as a sanitary material. The whitewashing often is included in the plasterers' work.

**188. Common whitewash** is made by slaking lump lime, and adding sufficient water to make a thin paste. By using 4 pounds of sulphate of zinc and 2 pounds of salt to each bushel of lime, the whitewash will be rendered much harder and will be prevented from cracking readily. The durability of whitewash, especially for outside work, may be increased by mixing 1 pint of linseed oil with each 2 gallons of whitewash, immediately after the lime is slaked. Whitewash may be tinted by the use of yellow ocher, Indian red, raw umber, indigo, bluing, or lampblack, the bleaching power of lime destroying most other coloring materials.

**189.** Whitewash may be applied to clean surfaces by means of a brush. When large surfaces are to be coated, it is economical to use a pump and hose which has a spray attachment. Rough and porous surfaces will take whitewash better than smooth and impervious surfaces. For new work, two coats should be applied, the first coat being allowed to dry before applying the second.

---

#### OVERCOATING

**190. Overcoating** is the process of covering the frame or exterior of an old building with stucco. The term is more generally used in connection with frame buildings, but the process is equally applicable to masonry buildings, in which case the previous directions as to stuccoing on existing masonry walls should be observed. Either lime stucco, Portland cement stucco, or magnesite stucco, may be used for overcoating.

**191. Advantages of Overcoating.**—When the exterior of a building becomes unsatisfactory in appearance, and fails to protect the building against the elements, the process of overcoating may be employed to improve the appearance of the building, and to render it less subject to weather conditions.

**192. Precautions to be Observed.**—Before commencing the overcoating, the building should be carefully inspected to determine whether it is in satisfactory shape to receive the work, and whether the expense will be justified. The frame of the building must be sound, the doors and windows made true, and the walls plumbed, before the work proceeds. While this is not the work of the plasterer, he must see that it is all in proper condition before he can hope to do satisfactory work.

**193.** Particular attention should be paid to the roof and to the drainage system. A tight roof is essential, and such repairing must be done as will insure against any leakage that might get in back of the finished stucco. Especial attention must be paid to the details of flashings and drips. A careful



design of the building at these points will prevent discolorations and disintegration due to water finding its way back of the stucco.

**194. Masonry Buildings.**—Stucco can be applied directly to the surface of masonry walls, provided that thorough cleanliness, a good mechanical bond, and proper absorption may be obtained. It is most important that masonry walls be clean before the stucco is applied. When the masonry surface cannot be brought to the condition of a base that will hold the stucco firmly, the surface should be furred out and lathed as is done for new work.

**195. Frame Buildings.**—When frame buildings are to be overcoated, they should be made structurally sound in every respect. If the old siding is in poor condition, so that the furring and lath cannot be held firmly, the siding should be removed, the walls covered with waterproof paper, and then furred and lathed, in the same manner as described for new work.

When it is necessary to remove the sheathing as well as the siding, the studs should be braced, and furring and lathing applied as described for back-plastered walls.

**196.** Where overcoating it to be done over beveled siding, flush, or novelty siding, clapboards, or shingles, the furring and lathing will cause the face of the stucco to be some distance out from the original surface, usually so far that the cornice, sills, and trim, will not show properly. It will be necessary to fur out for the new positions of cornice members, and to reinforce the outside edge of window sills to conform to the new outside surface of the walls. A face molding of suitable size will be required around the edges of window, and door, casings, and other trim must be built out as required. All the trim should be placed in such a manner that it will show its proper projection in relation to the finished stucco surface.

A typical method of adapting overcoating to a building having beveled siding is shown in Fig. 73. A new molding is placed at *a*, against which the stucco finishes. The trim of the window is built out by means of a new cap *b*, the lower mold-

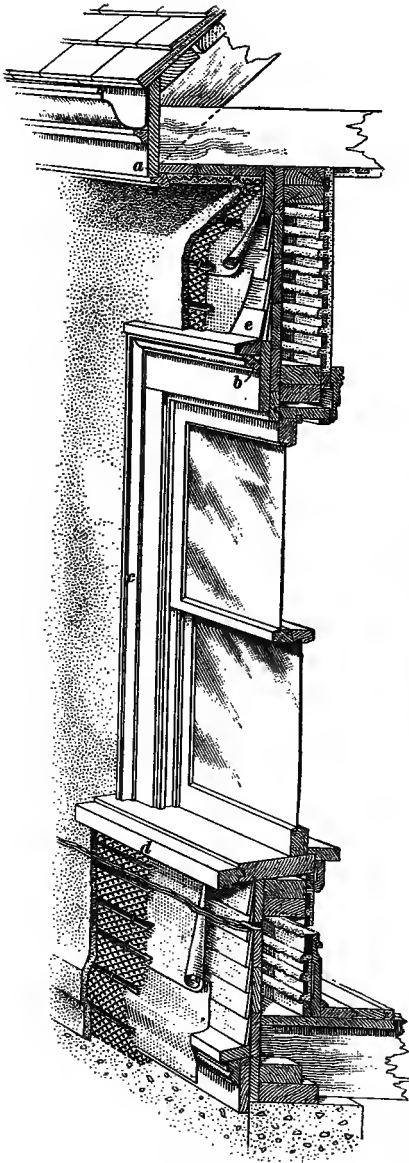

FIG. 73

ing of which extends down the jambs at *c*, to an extension sill *d*. The backs of moldings *a* and *c* are beveled, so as to cover the joint between the molding and the stucco, and to hold the stucco firmly in place. Flashing *e* is built in over the head of the window to prevent any water from getting back of the woodwork at that point. Ribbed furring lath is then placed on the siding, or furring may be used to support plain lath.

Ordinary wood lath is sometimes used for furring, but it is not as desirable as furring  $\frac{5}{8}$  inch thick, as there is less space for plaster behind the lath.

It is always desirable, when overcoating over sheathing or siding, to cover the surface with waterproof paper before applying the furring, as this will keep the moisture of the stucco from being absorbed by the siding. It will also make a warmer house in winter.

















