



11/23

LIBRARY  
OF THE  
UNIVERSITY OF CALIFORNIA.

567  
V-97  
*Class*













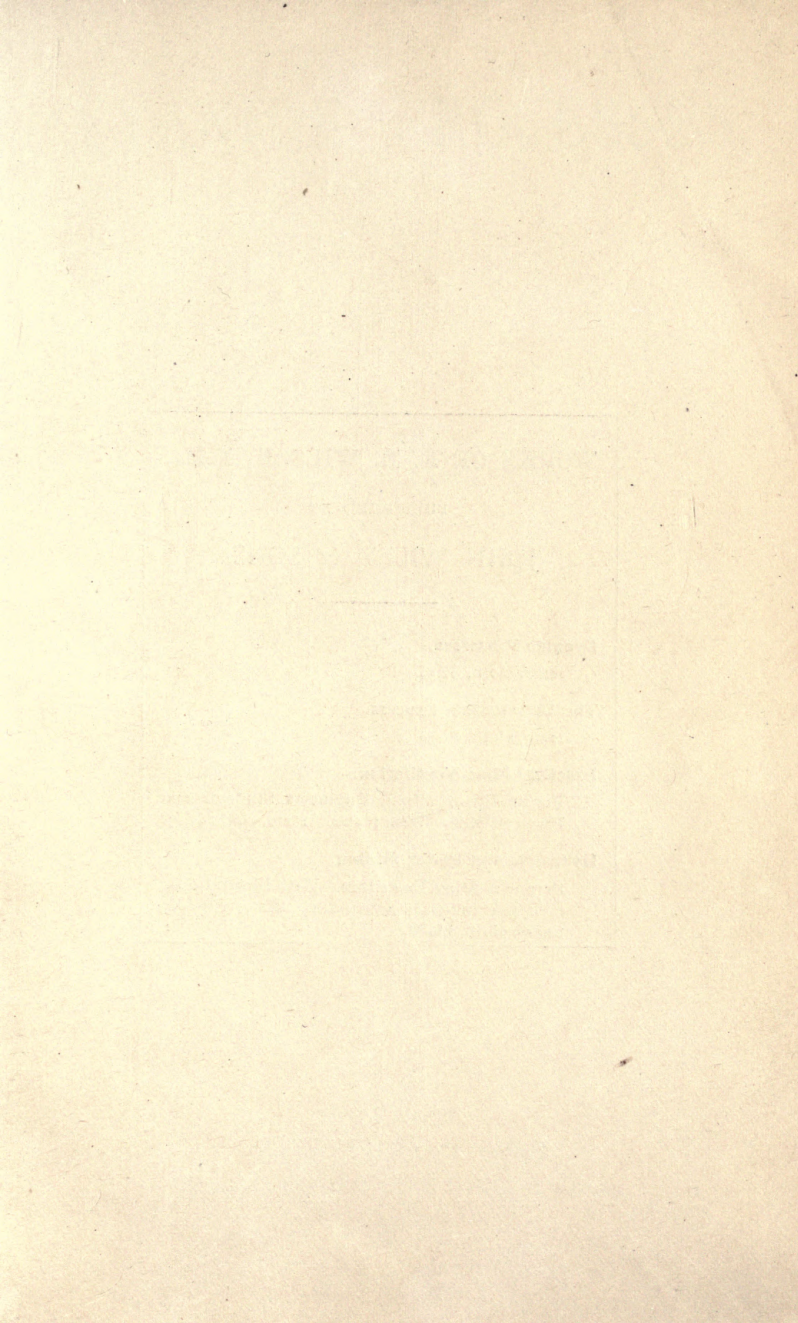



**WORKS OF E. B. WILSON, E.M.,**

PUBLISHED BY

**JOHN WILEY & SONS.**

---

**Cyanide Processes.**

12mo, cloth, \$1.50.

**The Chlorination Process.**

12mo, cloth, \$1.50.

**Practical Mine Ventilation.**

For the Use of Mining Engineers, Students, and  
Practical Men. With plates. 16mo, cloth, \$1.25.

**Hydraulic and Placer Mining.**

Second Edition, Rewritten. With illustrations,  
including full-page half-tones. 12mo, vi+355  
pages, cloth, \$2.50.

# CYANIDE PROCESSES.

BY  
E. B. WILSON, E.M.



*FOURTH EDITION, REVISED AND ENLARGED.*

FIRST THOUSAND.

NEW YORK:  
JOHN WILEY & SONS.  
LONDON: CHAPMAN & HALL, LIMITED.  
1908.

TN767

W7  
1908

GENERAL

Copyright, 1895, 1902, 1908,  
BY  
E. B. WILSON.

The Scientific Press  
Robert Drummond and Company  
New York



## PREFACE.

---

OWING to the recent improvements in cyanide practice, especially in the treatment of slime, the author adds a chapter giving the latest treatment, thus bringing the fourth edition up to date.

Since the first edition, the volume of literature on the subject of cyaniding has increased twelve-fold (one fold for each year), and while many theories have been proved and disproved, there remains much to learn, although the process is an established metallurgical one. Cyaniding has continually widened in scope to an extent that ores are now successfully treated which were once considered beyond the capabilities of the process; however, it has not reached a stage where it can be universally applied to the extraction of gold and silver. This is due to impurities in ores which make the cost of preliminary treatment so high that when added to the cost of cyaniding no profit remains. Metallurgists find that ores vary to such an extent at different mines, the process must be changed to meet conditions, and at times it can not be employed. This is mentioned here because many think cyaniding is applicable to any ore, and that anyone can run a

cyanide plant. Were the mass of facts, fancies, and details that have been advanced concerning cyaniding incorporated in this book, the reader would be more confused than enlightened, therefore the author takes up the first principles, and discusses those matters which have an actual bearing on the subject. With the main facts, as outlined in this book, thoroughly digested, the metallurgist need not work haphazard, or the reader be mystified, and any investor can readily understand that practical work must be an element of success in this as in any other undertaking.

The details of plant construction are purposely omitted, since they vary at each mill and must be worked out by the engineer and performed by masons, carpenters, and millwrights. The detailed construction of machinery and apparatus is likewise omitted, as they are purchased from mill supply houses ready made and from designs that have been tested. By dealing with the subject in this manner a large mass of generalities is eliminated from the text, to the advantage of those seeking facts about the process rather than mechanical details. Experimental work that has a practical bearing on the subject is furnished, but history and padding is omitted in order to appeal to those who wish to benefit from a study of the subject.

E. B. WILSON.

June 12, 1908.

# CONTENTS.

---

	PAGE
PREFACE .....	iii
CHAPTER I.	
ORES SUITABLE FOR CYANIDE PROCESSES.....	I
CHAPTER II.	
POTASSIUM CYANIDE AND OXYGEN.....	14
CHAPTER III.	
CHEMISTRY OF THE PROCESS.....	25
CHAPTER IV.	
LABORATORY TESTS.....	38
CHAPTER V.	
PLANTS FOR CYANIDING.....	55
CHAPTER VI.	
LEACHING THE ORE .....	74
CHAPTER VII.	
PRECIPITATING GOLD FROM CYANIDE SOLUTIONS .....	86



## CHAPTER VIII.

	PAGE
TREATMENT OF BULLION.....	118

## CHAPTER IX.

TREATMENT OF CONCENTRATES AND SLIMES.....	125
---	-----

## CHAPTER X.

ELECTRICITY APPLIED TO CYANIDING.....	135
---------------------------------------	-----

## CHAPTER XI.

ELECTRODES.....	151
-----------------	-----

## CHAPTER XII.

THE CURRENT.....	160
------------------	-----

## CHAPTER XIII.

ANODES.....	165
-------------	-----

## CHAPTER XIV.

CATHODES.....	170
---------------	-----

## CHAPTER XV.

SIEMENS-HALSKE AND PELATAN-CLERICI PROCESSES.....	175
---	-----

## CHAPTER XVI.

CYANIDING SLIMES.....	187
-----------------------	-----

## CHAPTER XVII.

GENERAL INFORMATION.....	225
--------------------------	-----

APPENDIX.

	PAGE
INSTRUCTIONS HOW TO PROCEED WITH THE TREATMENT OF A CASE OF CYANIDE POISONING IN THE ABSENCE OF MEDICAL TREATMENT.....	233
INDEX.....	239







# CYANIDE PROCESSES.

---

## CHAPTER I.

### ORES SUITABLE FOR THE CYANIDE PROCESS.

**Definitions.**—Any mineral that it will pay to work is an ore. There are two classes of ores which contain gold, termed free-milling and refractory, and as they both enter into this discussion their character should be understood.

**Free-milling Ores** are those which have their gold particles in such a condition that when liberated from enclosing rock they are free to alloy with mercury.

Gold in free-milling ores is not entirely dissolved by mercury, in fact 60 per cent is a high recovery by amalgamation.

When treating such ores the usual procedure is to stamp them wet, and amalgamate as much of the gold as possible in the mortar and on the plates outside the mortar. The plates are either of copper coated

with quicksilver, or else are copper plates silver-plated and then coated with quicksilver. They are given a fairly good slope to allow the pulp to flow over and from their surfaces freely. The gold not caught in the mortar or on the plates will be lost if the tailings are allowed to waste, therefore at well-regulated mills they are impounded in settling-dams or other contrivances which will allow them to settle from the water holding them in suspension; or they are led direct to the cyanide vats; or still another process, that of concentration, may be practised.

Some of the reasons advanced to account for the comparatively small recovery of gold from free-milling ores are: (*a*) that the particles are so small and light that they float away; (*b*) that the particles are covered with a film of clay, grease, or sulphur; (*c*) that the gold is rusty, tarnished, or covered with a film of oxide. Whatever the cause at any particular mill, those portions of the gold which are not recovered are virtually refractory as far as amalgamation is concerned.

**Refractory Ores.**—Those ores which are not free-milling, and whose gold refuses to alloy with mercury in the mortar or on the plates, are refractory. Many ores which are free-milling at the surface become refractory as soon as water-level is reached and the atmospheric agencies cannot readily affect or, as it is called, oxidize them. Such ores may sometimes be

effectually treated by cyaniding after preliminary treatment. Ores containing sulphides, tellurides, arsenides, bismuth, selenium, and possibly some other metalloids are in the refractory class.

The usual method of treatment for such ores if they are to be lixiviated is to crush in a rock-breaker, dry in a furnace, pulverize by rolls or stamps, roast to drive off the volatile substances and oxidize the base metals, and then leach in tanks.

**Concentrates.**—Those portions of ores which have been treated in the stamp-mill and proved refractory may contain sulphides which enclose gold. The sulphides, being of greater specific gravity than the gangue, can be separated from it and the valuable portion of the ore thus reduced in bulk. Concentration of this description depends upon the difference in weight between the valuable and worthless minerals, and is accomplished by gigs, hydraulic classifiers, and bumping-tables.

Sulphides may be concentrated direct from ores without preliminary treatment, and such is the usual practice with refractory ores. The operation of concentrating sulphides will not differ from that for tailings.

**Tailings.**—That portion of ore remaining after amalgamation is termed the tailings. At some operations these may be worked profitably by the cyanide process.



In South Africa the ore treated by cyaniding belongs to this class. Tailings which contain \$3 in gold can sometimes be worked at a profit by this process, since as high as 90 per cent of the gold can sometimes be extracted. Since ore must be stamped for amalgamation, the treatment of tailings can be accomplished for simply the cost of handling and chemicals. There is often considerable gold in tailings half amalgamated that is covered with mercury but not alloyed; such gold is not attacked by cyanide and will not be recovered until the mercury is removed. Fortunately the quantity of gold in such a state is not large. Amalgam is sometimes scoured from the plates and gets into the tailings; this also is sometimes a loss, for cyanide will not attack the amalgam readily.

**Slimes.**—Considerable ore becomes impalpable during crushing, and this mixed with water floats away as *slime*, which at times carries a large portion of the gold; hence it is important that the water containing such fine material should be led to settling-tanks or ponds. When settling-tanks are employed the stuff would not settle for days unless some artificial means were adopted to hasten the operation. It has been found that the addition of a little lime, soap, or alum will precipitate the slimes in a short time. Too much lime should not be added; but this is a matter to be determined by experiment, and not one for which a

rule can be formulated. Fine slimes are unavoidable, and in the case of clayey or oxidized ores may be in such quantities as to prevent percolation unless washed off and treated separately.

Some idea of the quantity of fine ore which is made in stamping may be obtained from an examination of the following data, which are the results of stamping through 30-, 40-, and 60-mesh screens.

Stamping to 30-mesh screen:

20 per cent remained on a 90-mesh screen.

18 " " " " 60 " "

13 " " " " 40 " "

Stamping to 40-mesh screen:

22 per cent remained on a 90-mesh screen.

12 " " " " 60 " "

Stamping to 60-mesh screen:

18 per cent remained on a 90-mesh screen; the remainder of the pulp passed through.

When it is considered that there are 8100 holes in a square inch of 90-mesh screen, and that only 18 per cent of the product would remain on the screen when stamping to a 60-mesh screen, some idea of the fineness of the material which passes through may be obtained.

Mr. E. G. Banks experimented to ascertain the relative values of the different finenesses of ore crushed to pass a 30-mesh screen:

	Per Ton.
2.16% remained on 40-mesh screen.	Value \$19.70
9.29%       "       " 60   "       "	" \$17.80
25.72%       "       " 80   "       "	" \$22.50
63.83% passed through 80   "       "	" \$26.75

(Sulphide ores are brittle and should not be pulverized fine when it can be avoided.) Such ores are readily converted into slimes by crushing with rolls.

(Dry stamping and crushing cause more slimes than wet stamping.)

The stamps falling on the ore drive the crushed particles up against the screens and, there being no water present to carry them through, they fall back into the mortar and possibly again go under the stamp, to be further pulverized. Dry stamping can be carried on almost as expeditiously as wet stamping. However the results are as described, and the system is not practised where it can be avoided.

When crushing with rolls the ore is first dried as in the case of crushing dry with stamps, but there is this redeeming feature, there are not so many slimes made.

**Gold and Silver** are each dissolved by potassic cyanide under certain conditions. The action upon coarse gold is slow, therefore in such cases amalgamation should precede cyaniding.

Silver in the form of chloride is readily attacked by



potassium cyanide solutions, while other silver ores with the exception of subsulphide  $\text{Ag}_2\text{S}$  are not.

**Degree of Fineness.**—In every class of metallurgical work uniformity in the size of product is desirable, but as this seems an impossibility, owing to the fine ore made during crushing operations, cyaniding is sometimes impracticable. However it may be taken for granted that the best results will be obtained when the product is uniform.

The degree of fineness required will depend upon the ore, that is, upon the manner in which the metal is encased in the ore. Porous ores will not need the same degree of fineness as hard compact ores, for in the former case the solutions can penetrate the ore and get to the metal, while they cannot in the latter.

An open porous ore might not need finer crushing than  $\frac{1}{2}$  inch, while a compact ore might require pulverizing to pass a 60-mesh screen.

Besides the avoidance of slimes when coarse crushing can be practised, there are other features which commend it, such as time saved in crushing, increased product from the stamps, decrease in the quantity of water required, and time saved in subsequent drainage. On the other hand, coarse crushing requires that the solutions be left longer in contact with the ore.

(Whenever ores must be crushed fine, the water drains slowly from them and they pack.) This is par-

ticularly the case with clayey or slimy ores. When drainage will not exceed  $\frac{1}{2}$  inch per hour, treatment by lixiviation is impracticable. The average speed of drainage should be at least 12 inches per hour independent of mechanical arrangements. If drainage does not come up to or exceed these figures, the slimes must be washed from the ore. In some cases it may be found advantageous to mix sand with the ore to increase percolation.)

(**Acid Ores.**—Certain ores which have been partially oxidized, such as sulphides, will, when placed in water, permit metallic salts to be dissolved from them. These metallic salts, if acid, will destroy cyanide and increase the cost of that chemical for the operation, besides lessening the recovery of gold. Such ores may sometimes be freed of acidity by a preliminary wash of water, or be neutralized by the addition of an alkali, such as calcium oxide or sodium hydrate.)

**Base-metal Ores.**—The base-metal ores are those containing antimony, iron, copper, lead, manganese, and zinc. Cyanide of potassium dissolves metals more or less, generally forming double salts. (The affinity of cyanogen for gold rather than the other base metals, with the exception possibly of copper, is such that the weaker the solution of cyanide is, the less likely are the base metals to be attacked.) Copper compounds physically hard are not acted upon, but when soft and

porous copper ores are in the solution they interfere with the process.

Copper carbonate ores have so marked a reaction upon cyanide solutions that it is necessary before treatment to subject them to either a calcining roast or to sulphuric acid treatment.

Dr. Scheidel found that 8 grams of a copper carbonate ore reduced the cyanide from 2.73 per cent to .05 per cent in fifteen minutes. Where such strong solutions are employed in tests, it is found that the gold is extracted quickly. In the case just cited 70 per cent of the gold was extracted, bearing out the former statement that weak solutions attack gold in preference to base metals. It is during the treatment of cupriferous ores that the selective action of weak cyanide solutions for gold becomes most apparent. An ore containing sufficient copper to decompose a 1 per cent cyanide solution would have a very much less effect upon a solution containing 0.25 per cent.

Antimony ores are under some conditions affected by potassic cyanide. This is true of stibnite or sulphide of antimony, which forms sulphide of potassium and sulphocyanogen. Such ores are very compact and require very fine crushing to avoid an excessive use of potassic cyanide.

Bismuth is said to act in the same manner as copper and antimony.



**Sulphide Ores.**—Clean, fresh pyrites are not acted upon by weak cyanide solutions, although it has been noted that the decomposition products of this mineral, such as iron sulphates, have a destructive effect. Copper pyrites are oxidized to a soluble sulphate at low temperatures, and this salt requires a greater heat to decompose it than iron sulphate.

**Galena**, or sulphide of lead, is slowly attacked by cyanides, but all its sulphur combines with cyanogen to form sulphocyanogen, while the lead comes into the solution as a hydrate.

**Zinc-blende**, or sulphide of zinc, is scarcely effected by cyanide more than pyrite,  $\text{FeS}_2$ . Zinc carbonate will act like any other base metal oxide and must be calcined.

**Alkaline Sulphides**, when formed in any manner during cyaniding, will cause a loss of gold, by precipitating it and coating it with a film of sulphur, thus preventing the solution from redissolving. If the chemist can invent some method of making the sulphur, forming antimony and copper sulphides unite with the cyanogen rather than the potassium, and thus prevent the formation of alkaline sulphides which precipitate and hold back the gold from solution, such ores could be treated as readily as the other sulphides. As it is, there seems to be some peculiarity in the sulphur of antimony and copper sulphides which allows them to

be attacked readily by potassic cyanide, forming the objectionable salt potassic sulphide,  $K_2S$ . It is presumed that, owing to the readily oxidizable nature of these two metallic sulphides, they are converted into sulphates and as such act upon the cyanide.

**Tellurium.**—Ores containing tellurium, such as petzite and calverite, do not seem to have a bad effect upon potassic cyanide solutions, while tellurium oxide is stated to be insoluble in cyanides. Tellurium ores are compact and require fine crushing; even then the action of the solution is slow.

It is customary to roast Cripple Creek, Colorado, ores in order to make them more porous and thus increase the rate of percolation, and at the same time leaching can be effected sooner. Experiments show that tellurium is soluble in the presence of sodium dioxide.

**Arsenical Ores**, such as those at Mercur, Utah, do not seem to greatly interfere with the cyanide operations at that place, since the largest plants in the United States are erected there. The ore is porous and readily permits the solutions to percolate, so that pieces  $\frac{1}{2}$  inch in diameter are successfully leached. Carbonaceous shales and sulphur seem to be the only materials that give trouble at Mercur. Cinnabar is quite abundant, but nothing is given out concerning its being injurious to the process, while its presence is

considered to be a good indication of gold. Cyanide seems to attack cinnabar, for when roasting the gold precipitates the men become salivated by the fumes unless careful.

**Manganese** does not seem to have much effect upon cyanide solutions, while

**Cobalt and Nickel** have a decided effect upon the consumption of cyanide, acting similarly to copper.

**Roasting Ores.**—In all probability if a dead roast is to be given to oxidize base-metal salts, the chlorination process will prove as economical in operation as cyaniding, provided no lime or magnesium is in the ore. There are, however, ores which do not need an oxidizing roast but merely a dehydrating roast to make them porous. Such roasting or calcining should not exceed a temperature of 300° F., otherwise they might sinter, especially if lime or magnesia were present. Leaching would possibly in such cases be retarded by the formation of hydraulic cement. Ores which are to be crushed dry must be given a dehydrating roast, otherwise they will clog the screens and not be sized properly; if, therefore, they are made more porous at the same time that they are being dehydrated, so much the better for the process. Dehydrating roast will not answer for chlorination; that process requires a thorough oxidizing and chloridizing roast. Some sulphides will not interfere with the cyanide process, but



it is possible that the heat for dehydrating may convert sulphides with the aid of moisture present into sulphates. This is especially important in the case of copper pyrite, since it seems to be the result of heat and moisture that converts them into the peculiar sulphates described.

The scope of the cyanide process can only be determined by experiment, for in one case the percentage of extraction will be high, while in another, with conditions almost similar, it will be low. To ascertain the fitness of an ore for the process, leaching tests should be made first in the laboratory and then on a larger scale.

## CHAPTER II.

### POTASSIUM CYANIDE AND OXYGEN.

**Elsner's Equation.**—That gold was soluble in cyanide of potassium solutions was known to Hagen in 1806. L. Elsner stated in 1844 that gold and silver could be dissolved in potassium cyanide without decomposition of water. He further stated that the dissolution of the metals was the consequence of the action of oxygen, which, absorbed from the air, decomposed part of the cyanide, thus forming a double salt, auro-potassic cyanide, which has later been stated in the following equation, known as "Elsner's Equation":

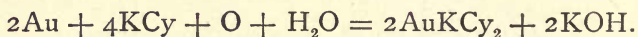

The first scientific literature on the subject is by Prince Bagration in 1843. He concluded his paper with the remark that in the future cyanide of potassium must be enumerated among the solvents of gold. Faraday made use of a cyanide solution to produce thin films of gold in 1857. Ten years later J. H. Rae took out the first patent for applying cyanide to obtain

gold from the ores direct. He was followed by Faucett in 1881; he in turn by Sanders in 1881; then by J. W. Simpson in 1885; finally by MacArthur and Forrest in 1889.

**Patents.**—An examination of the patents granted for cyanide processes and improvements shows that it is an easy matter to obtain a patent, but a difficult matter to retain it if some one else wants to make use of anything claimed in the patent. The inventions for this process have been many, but the improvements few.

The MacArthur-Forrest patents are not valid except in so far as they apply to the precipitation of gold from cyanide solutions by zinc filaments.

The zinc-fume precipitation process has been decided against the owner of the patent.

The precipitation of gold from solutions by charcoal was in use long before Johnson's patent.

What is now termed the pneumatic cyanide process was not considered worth patenting by the author, although it was undoubtedly originated in this country as soon as in New Zealand.

**Oxygen and Cyanide.**—Elsner's equation at one time caused much comment, but it has now been satisfactorily settled that oxygen plays an important rôle in the process. A pure solution of potassic cyanide will not dissolve gold to any great extent when the latter



is immersed in it, but dissolves it readily when oxygen is present. For example, if gold-leaf is placed on the surface of a cyanide solution, it will dissolve in a few minutes, and the stronger the solution the quicker it dissolves; however, if submerged in the solution it dissolves but slowly, the strength of the solution affecting its rate of dissolution but slightly.

MacLaurin of New Zealand in his experiments used gold-leaf of uniform thickness, and his deduction was that oxygen was necessary for the solution if cyanide was to dissolve gold with any rapidity. A piece of gold-leaf placed in a stoppered bottle lost 0.18 per cent of its weight in ninety-two hours.

Another piece placed in an open bottle lost 9.1 per cent of its weight in sixty-two hours. Still another piece placed in a bottle with oxygen lost 24.2 per cent of its weight in ninety-six hours. The strength of the solutions was identical in every instance.

Experiments were made by the State Mining Bureau of California with dilute cyanide solutions upon metallic gold.

With a 1 per cent solution it was found possible to dissolve such gold-leaf as is used by sign-painters in one hour. When dentists' foil was used, about six times thicker than painters' foil, it required forty-eight hours to dissolve.

Mr. J. B. Hanney verified Elsner's equation and

MacLaurin's experiments in a practical way. His theory was that dilute cyanide solutions acted more rapidly on gold. He attributed this to the cyanide displacing oxygen by dissolving in the water, and that therefore gold could not dissolve until oxygen had been absorbed from the air. To carry out this theory he treated ores with dilute and then with strong solution.

He found that the rate of dissolution of gold increased with the strength of the solution, provided oxygen of the air could come in contact with the gold.

Mr. Hanney invented an electro-chemical apparatus which he used in his experiments. In direct opposition to this Mr. Miller has patented an apparatus to keep the air away from the solution.

From MacLaurin's experiments the following is deduced:

1. That oxygen is necessary for dissolving gold in a cyanide solution, and that it combines with the potassium of the potassium cyanide in the proportion required by Elsner's equation.

2. The rate at which gold is dissolved in a solution of potassium cyanide passes through its maximum in passing from dilute to concentrated solution, due to the fact that the solubility of oxygen in a cyanide solution decreases with the concentration.

Various ideas have been advanced in order to hasten the solution of gold in cyanide solutions, most of them depending upon increasing the quantity of oxygen. Agitation has been employed with this end in view, but, owing to an excessive increase in the quantity of cyanide, it has not been widely adopted, except for slimes.

Several forms of agitators, such as paddles to stir up the ore and solution, drawing off the solution and rushing it back in again from the bottom of the vat, circulating the pulp by centrifugal pumps, and pneumatic agitation, have been employed with more or less success.

There is no question but that agitation quickens the leaching process, but it may be surmised from its slow introduction that the added cost necessary for power is a drawback.

Agitation may in some cases be economical in practice, and there are no doubt many instances where by agitation triple the quantity of ore can be leached in a given time at the same total cost.

One item in favor of agitation is the speed with which tanks can be discharged where proper arrangements have been perfected for the purpose.

Agitation at present finds its greatest employment in treating slimes and ore which cannot be percolated in regular cyaniding.



**Chemicals for Oxidation.**—For the purpose of hastening the leaching operation several inventors have worked along the lines of furnishing oxidizing agents of a chemical nature to replace the oxygen of the air.

Several chemicals are capable of liberating nascent cyanogen in a cyanide solution, particularly potassic chlorate, nitrate, permanganate, bichromate, and the peroxides of barium, manganese, lead, and sodium. Besides these the haloids iodine and bromine act in a vigorous manner. All of these compounds act as oxidizing agents when added to a potassium cyanide solution, and increase the solubility of gold, some by adding oxygen and others by taking the place of oxygen. Among the most convenient is peroxide of sodium and peroxide of hydrogen. In 1893 J. C. Montgomerie obtained patents for the use of sodium peroxide, sodium oxide, and sodium hydrate as oxidizing agents, although experiments were made by Prof. Christy in 1892-3 with the same oxidizing agents.

**Cyanogen Bromide.**—Experiments made by Prof. Christy in 1894 showed that if cyanogen bromide was added to a solution of potassium cyanide, potassium bromide was formed and cyanogen liberated as follows:

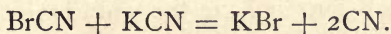

In the presence of metallic gold and in an excess of

potassium cyanide the double salt auro-potassic cyanide was formed, and potassium bromide as well:

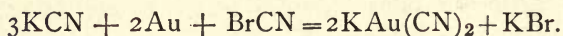

Messrs. Sulman and Teed claim to have made the first discovery of this reagent, and in fact received an English patent in 1895. A. W. Warwick, E. A. Schneider, and yet another make the same claims about the same time, but probably? Prof. Christy's experiments antedate them all.

A simpler process, such as the use of bromine-water, was next tried. The reactions were analyzed as follows:

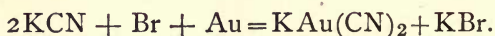

To use bromine in either case requires experience and skill, otherwise a great loss of cyanogen will occur and poor results follow. The reason given for this is that free cyanogen has a tendency to oxidize into certain impure compounds; consequently if cyanogen is set free faster than the gold can reach it, a loss of cyanogen occurs. Strong solutions of bromine and cyanide of potassium should be avoided, for if there is no contact with gold when cyanogen is set free there will be a decided loss. It not being possible in ordinary lixiviation to have the gold in intimate contact with cyanogen continually, there must inevitably be a loss of cyanogen which will mitigate against the

use of bromine, although the combined use of KCN and Br will dissolve four times as much gold in a given time. A further drawback to the use of the mixture is the increased cost of the solution and the loss of chemicals.

**Chlorine-water.**—Chlorine-water may be used instead of bromine-water.

This might suggest itself, as chlorine is one of the haloid salts.

According to theoretical deductions,

1	ounce	of	bromine	should	dissolve	2.45	ounces	of	gold
1	"	"	chlorine	"	"	5.52	"	"	"
1	"	"	oxygen	"	"	24.5	"	"	"

The bromine process has been in practical operation, performing the leaching operation in fifteen hours, with a consumption of 4 ounces KCN and 1.75 ounces BrCN. The percentage of extraction is said to be about 90.

Considerable criticism of this process has been indulged in by people interested in other processes, but it may in the future demonstrate its usefulness.

**Iodine.**—The reaction which occurs in case iodine is employed in a potassic cyanide solution to hasten the solution of gold may be stated as follows:

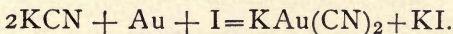

The results and deductions obtained are somewhat



similar to those mentioned above and need not be repeated.

On the whole the extra cost of treatment and the loss of cyanogen have been such that atmospheric oxygen is employed wherever possible.

From what has been said it is evident that without oxygen or an oxidizing agent potassium cyanide has absolutely no action upon gold, and that if sufficient oxygen is not present it must be supplied artificially. In some instances the entire solution is drawn off that the air may follow the solution down through the ore, but it will not be policy to aerate the cyanide solutions unless in contact with the ore, on account of a loss of cyanogen which will result.

There is danger in using too much oxidizer, as secondary reactions will probably occur, especially if the ores contain sulphides, arsenides, antimonides, and lead; for if free cyanogen is liberated faster than it can come in contact with the gold, it will run down into oxidized products without doing any good.

This is one reason why without care and expert supervision the cyanide process is not as successful as it should be with low-grade ores.

It seems to be the free cyanogen only that attacks gold, and if potassic cyanide is in excess, paracyanogen is formed which absorbs oxygen and prevents cyanogen from attacking the gold. This is better illustrated by

stating that while the time occupied by extraction will be less for a strong solution, the consumption of cyanide will be more than if a weak solution were used.

Yet this does not always hold good, as the following experiments will show:

- (1) KCN solution before experiment 1.0809 per cent  
 KCN " after " 0.5145 "  
 Loss of KCN . . . . . 0.5664 per cent  
 Extraction in 15 hours; Au, 0.5 mg.; Ag, 72.45 mg.
- (2) KCN solution before experiment 0.5404 per cent  
 KCN " after " 0.0837 "  
 Loss of KCN . . . . . 0.4567 per cent  
 Extraction in 15 hours; Au, 2.3 mg.; Ag, 138.4 mg.
- (3) KCN solution before experiment 0.1081 per cent  
 KCN " after " 0.0042 "  
 Loss of KCN . . . . . 0.1039 per cent  
 Extraction in 15 hours; Au, 2.2 mg.; Ag, 103.3 mg.

It will be noted that with the weaker solutions the percentage of gold and silver extracted was more than with the strong solution; it is advisable, therefore, to test ores to ascertain the weakest cyanide solution that will extract the most gold from a given ore with the least loss of cyanide.

Experiments made with sodium peroxide and hydrogen peroxide in potassium cyanide solutions, and

with potassium cyanide clear, may be interesting at this time, as illustrative of their various capacities for dissolving gold and silver. The experiments were made on Cripple Creek telluride ores. Time of leaching, 40 hours.

0.5 per cent KCN solution dissolved .36 mg. Au from 0.76 mg. Au.

0.5 per cent KCN + 1.16 gm.  $N_2O_2$  dissolved .66 mg. Au from .76 mg. Au.

0.5 per cent KCN + 10 c.c.  $H_2O_2$  dissolved .51 mg. Au from .76 mg. Au.

10 c.c.  $H_2O_2$  = 1.16 gm.  $N_2O_2$  = 0.238 available oxygen.

Further experiments made with such oxidizing agents as potassic permanganate and bleaching-powder were not successful.

## CHAPTER III.

### CHEMISTRY OF THE OPERATION.

**Chemical Processes.**—Cyanide lixiviation has but one competitor, chlorination, but both processes are not always adapted to the same ores, so that in many cases they have distinctive fields for exploiting. It was formerly thought that a rough laboratory test upon a few pounds of ore would be sufficient to determine whether an ore could be successfully treated by cyaniding. This test is not now considered sufficient, but should be supplemented by a five-ton test at least, for several ores which have given excellent extraction by laboratory tests have failed utterly when larger quantities were treated. This was not due to the chemist, but to the ores, which probably were picked samples. It is a fairly well-known fact that an interested party cannot sample his ore properly, neither can he send proper samples to a testing-mill, it would seem, for nine times out of ten he will send picked or average samples when he should send run-of-mine ore, as it is usually in the latter that the trouble will be found. Tail-



ings are of course not included in the above remarks. The scope of a chemical process for gold treatment is limited, and while it may answer admirably so long as certain minerals are absent, it may not work at all if they be present; for which reason it is advisable to have all the minerals in the ore likely to be encountered in ordinary mill working, rather than have extra quantities of gold in the samples. If, under such conditions, the chemist's deductions are favorable, one can depend upon the success of the cyanide treatment from his tests. After the ore has been established as fit for the process, there is little danger of its proving unsatisfactory, unless the ore changes materially.

The value of any process depends upon the profits obtained—another matter which should be considered thoroughly before the process is adopted.

The writer is more conservative at this time than when he first wrote on the subject, for he has noticed that Mr. Paul's statement is not to be relied upon in all cases, viz., "that if laboratory tests were satisfactory on 50 pounds of ore, he would not hesitate to build a mill on that test, so uniform are the results obtained."

The chemical reaction of the cyanide process is such that after the chemist has determined the proportions of chemicals to be used in the treatment of any particular ore that has proved to be susceptible of

cyaniding, the work becomes practically mechanical. This statement has been criticised, nevertheless there are men working the cyanide process successfully who know little of its chemistry and no other chemistry at all.

**Elsner's Equation.**—The chemical reaction expressed by Elsner's equation for gold is

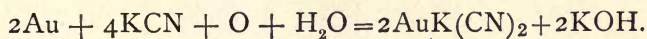

For silver it is

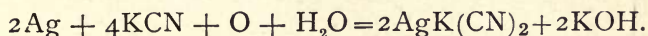

The equations show that double salts are formed: the gold salt termed aurio-potassic cyanide, the silver salt argentic-potassic cyanide, and also another product of the reaction, termed potassic hydrate or caustic potash. The double salts are quite stable, that is, are not easily decomposed; in fact, it is hardly possible to accomplish their dissolution without using a highly electro-positive metal or its equivalent. For that reason zinc in some form or an electric current seems best adapted to the purpose.

In case the salts are broken up the cyanogen will immediately unite with the potassium of the potassic hydrate if a molecule is near and potassium cyanide be regenerated, otherwise the liberated cyanogen will form zinc-potassic cyanide or some paracyanogen and a loss occur.

**Cyanicides.**—The term cyanicides includes all those agents which are destructive to cyanogen so far as they interfere with the extraction of gold, and also those agents which unite with the potassium and prevent the regeneration of potassium cyanide.

The cyanicides are usually base-metal salts forming mineral acids, but there are other factors, such as decomposition due to carbon dioxide, or to those portions of the ore soluble in cyanide solutions.

**Acid Ores.**—Ores containing partially oxidized sulphides are destructive to cyanide, for which reason they must be entirely oxidized by roasting or have their mineral acids removed by washing if possible. If this is not feasible, the salts must be neutralized by some alkali.

It has been stated that clean iron pyrite is not injurious to KCN, but it is to be understood that sulphide ores or concentrates exposed to the weather will oxidize quickly and become sulphates. When such ores come in contact with cyanide, taking pyrite, FeS<sub>2</sub>, as an illustration, the following reactions undoubtedly occur:

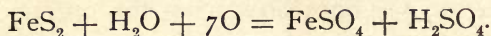

The acid formed must be washed from the ore whenever it occurs free, otherwise free hydrocyanic acid will be liberated and probably lost. Thus:

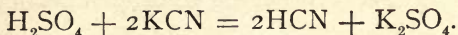

In case the acid is not washed out there is a possi-

bility that the free hydrocyanic acid may attack the gold and assist the leaching. Undoubtedly this would be the case if there were plenty of gold and nothing else attractive to prussic acid, but gold particles in ore are few and far between, and the chances are very much against their being dissolved by the acid. There are instances where the mineral acids are actually a great help to the process; for instance, where the fine gold is covered with an oxide which prevents its absorption by cyanide.

In such cases the mineral acid will free the gold and form metallic salts which would act as a cyanicide if not neutralized or washed away. Take for illustration

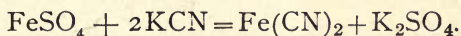

Were lime added to neutralize the acid salt before the potassium cyanide was admitted to the ore the following reaction would occur and render the salt harmless, thus:

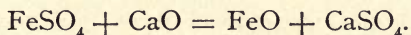

Ferrous oxide is a powerful base and would neutralize acid; on the other hand it also absorbs oxygen readily and might pass into ferric oxide, thus:

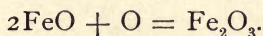

This is a feeble base and would have little effect; besides in all probability it would be carried off in the water used to wash away the calcium sulphate.



If the ferric oxide is not carried off, it will combine with the cyanide to a greater or less extent, but seems to have no very serious action.

While ferrous salts, soluble or insoluble, exist in the ore, lime or soda will combine with the acid to deposit ferric oxide. Ferrous sulphate could also form an insoluble basic sulphate.

Berzelius gives the reaction between ferrous sulphate and oxygen as follows:

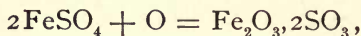

thus forming an insoluble basic sulphate.

The reactions of the sulphates of alumina and magnesia are practically the same as ferrous sulphate with cyanide, the free prussic acid being a loss in most instances.

**Ferro and Ferri Cyanides.**—The reaction of ferrous salts with potassic cyanide is given as follows:

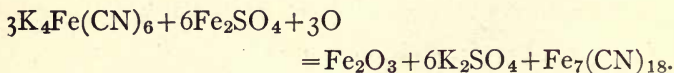
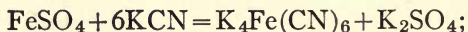

The potassium ferro-cyanide of the first reaction is converted into ferri-ferro cyanide or Prussian blue. This is the case only when the ferric salt is in excess; when there is a similar mixture with the ferrous salt in excess Turnbull's blue is formed, thus:

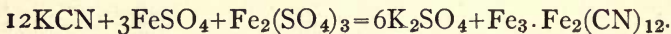

The reactions between the iron compounds and potassium cyanide are very complicated, and besides they are not fully understood, yet it is known that the reactions above take place and that a considerable cyanide loss occurs through them. If metallic iron be present in solutions of cyanide with gold, there will be no loss of cyanide due to its presence, a matter which permits of the use of iron tanks; but the tank iron will be more or less corroded and for that reason should be well coated with preservative, like paraffine paint. As an illustration take the following possible equation:

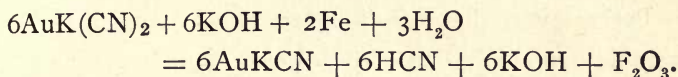

In this equation the free prussic acid would combine at once with the free alkali to form potassium cyanide:

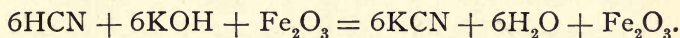

The first reaction shows that it is possible, if a metal is present, to regenerate potassium cyanide, and this actually occurs in zinc precipitation.

**Carbon Dioxide.**—The reaction of carbon dioxide on potassium cyanide is as follows:

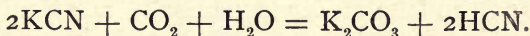

The sources from which carbon dioxide may come to affect the solution are the atmosphere, carbonate ores, charcoal, or other organic matter. The prussic acid

set free according to the reaction would unite with whatever cyanide was adjacent to its molecules.

**Charcoal.**—It has been long known that charcoal would precipitate gold from cyanide solutions, but the reaction is somewhat doubtful if it be not due to the carbon dioxide in the charcoal.

Charcoal, after some hours' contact, causes a loss of cyanogen by setting free prussic acid, possibly according to the following reaction:

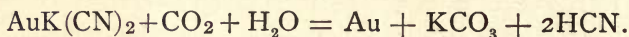

Parks found that very long contact was required for complete precipitation of gold from cyanide solutions. In New Zealand, where the ore was kiln-dried, considerable loss of cyanide occurred from charcoal getting into the ore and hence into the solutions.

**Consumption of Cyanide.**—According to Elsner's equation 1 pound of potassium cyanide should dissolve about 1.5 pounds of gold, but this is not approached in practice, the rule being that it takes between thirty and forty times that quantity. The loss is due to cyanicides, and is dependent chiefly upon the character of the ore and its associate minerals, but there is a certain quantity lost in the zinc-boxes and wash-water, also some is left in the tailings due to capillarity. It is presumed that fine ore will retain more cyanide solution than coarse ore, but this may be questioned,

for coarse ore in most cases requires a longer time for the solution to enter its pores, and it will require a longer time for it to come out. Again, capillarity and the weight of the liquor assists in forcing the solution into the ore, but does not assist in bringing it out; in fact in very small interstices there is nothing which will bring out the solution except heat. Where the ore is porous the extraction is greater, and the loss of cyanide less than where the ore is tight with very small subcapillary openings. In all probability the loss of cyanide is in a very great measure due to the condition of the ore, rather than to cyanicides; at least it would appear so from laboratory tests on small quantities of ore where cyanicides can be readily determined and due allowances made to overcome them.

During washing there is a dilution of the cyanide solutions, a large portion of which cannot be used to make up fresh solutions. The consumption in modern practice is from  $\frac{1}{2}$  to  $1\frac{1}{2}$  pounds KCN per ton of ore.

**Determination of Cyanide Consumption.**—Should the consumption of cyanide be high, due to cyanicides, the cause may be determined by an analysis of the solution. For example, 1 part by weight of iron consumes 7 parts by weight of potassium cyanide, according to the former equation:

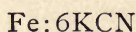
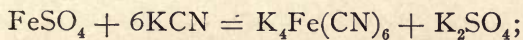

$$56 : 390 = 1 : 7.$$



In the case of zinc sulphate:

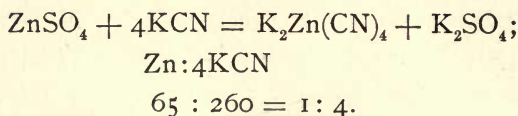

In the case of copper sulphate:

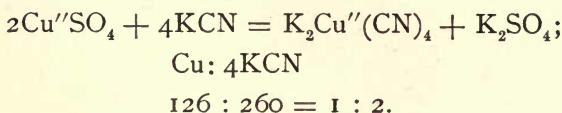

There are many reactions which occur in the cyanide process not yet understood, for which reason the scope of the process is still narrow. Probably the widest field for cyanide extraction is yet to be developed, but at present its distinctive field lies in the treatment of tailings.

Salts of aluminium and magnesium act in a different manner with potassium cyanide, their hydrates being formed with the liberation of hydrocyanic acid, thus:

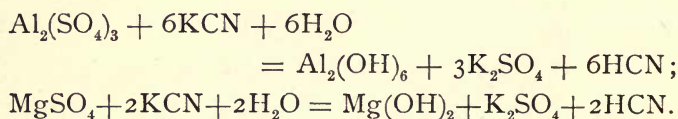

A preliminary alkaline treatment overcomes this objectionable feature, their hydrates being precipitated, which are then inert towards potassium cyanide, thus:



insoluble magnesium hydrate and insoluble calcium sulphate being formed.

Soluble sulphides, formed by the action of potassium

cyanide on some metallic sulphides, again react to some extent on the cyanide, with the formation of sulphocyanide of potassium, thus:

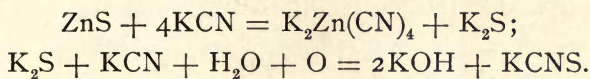

To determine the cause of the consumption of cyanide place 100 grams of the pulp in a wide-mouthed bottle, add 200 c.c. of the cyanide solution and agitate for fifteen hours. Filter, take 20 c.c. of the filtrate (equivalent to 10 grams of ore) and evaporate almost to dryness in a porcelain dish. Add some strong sulphuric acid, evaporate almost to dryness, and cool. Dilute with water, add some hydrochloric acid, and heat to effect solution if necessary. The metal in solution may now be determined by the usual methods.

The strong sulphuric acid at a high temperature decomposes the metallic cyanides, thus:

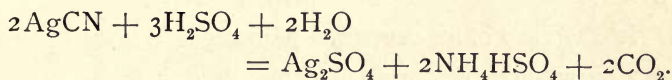

Strong nitric acid may be used in place of strong sulphuric; but hydrochloric cannot be used, as it leaves the metal in the form of a double cyanide salt, which is soluble.

The reactions with nitric and hydrochloric acids are:

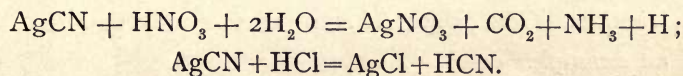

**Determination of the Cause of Non-extraction.**—Should the above tests show a low percentage of extraction, the next step is to determine the cause of this non-extraction. It may be due to numerous causes, such as total destruction of potassium cyanide by certain salts of the base metals present in a form readily attacked by the potassium cyanide. The gold may be in a very coarse state, in which case the solvent action of the potassium cyanide will be too slow for the practical application of the process. The gold may be combined or alloyed with tellurium, antimony, bismuth, etc., in which case the cyanide is inoperative until the combination is broken up. There may be present soluble sulphides in solution. Gangue, such as kaolin or talc, may be present in such quantities as to effectually prevent percolation. To overcome these difficulties the following methods may be tried:

In the case of an ore which consumes a large quantity of cyanide, if a preliminary wash with water, weak acid, or alkali is ineffective, such ore may be classed as one not adapted to the process.

The coarse-gold difficulty may be overcome by amalgamation, either before or after treatment with cyanide, which generally results in an excellent extraction. The South African practice may be cited as an example.

The difficulty due to the presence of bismuth, antimony, etc., in combination or as an alloy with the gold, may sometimes be overcome by fine grinding and long contact with the cyanide solution; but the usual method is to treat the ore to a preliminary roast, which converts the gold into a condition in which it is readily attacked by cyanide.

The difficulty due to the presence of soluble sulphides can be overcome by the addition of a soluble lead salt or the addition of an oxidizing agent.



## CHAPTER IV.

### LABORATORY TESTS.

**Determination of Acidity in Ores.**—Should an ore be acid, the result will be decomposition of potassium cyanide unless this acidity is destroyed before the cyanide solution is added.

*Soluble Acidity.*—Agitate 10 grams of the pulp for 10 minutes with 50 c.c. of water; filter, and test the filtrate with litmus paper for acidity. Should acidity be shown, wash the ore until the washings no longer give an acid reaction when tested with litmus paper. Now titrate the total filtrate with deci-normal caustic soda solution, until the neutral point is obtained, using litmus as an indicator.

*Latent Acidity.*—Transfer the washed ore to a small porcelain evaporating-dish; cover with water; add a measured excess of deci-normal caustic soda solution; stir and titrate the excess of soda with deci-normal acid solution. This gives the latent acidity.

*Total Acidity.*—The sum of the above tests gives the total acidity, but, as this is frequently all that is

required, it may be determined as follows: Introduce 10 grams of the pulp into a stoppered bottle with some water; add a measured excess of the caustic soda solution, agitate for 20 minutes and then titrate back with deci-normal acid solution.

The soluble acidity is due to salts with an acid reaction, such as ferrous sulphate, zinc sulphate, copper sulphate, etc., or to free sulphuric acid from the decomposition of pyrite, to tellurous acid, etc. It may be overcome by giving the ore a preliminary wash with water. This washing is followed by treatment with a weak solution of caustic soda or caustic lime, which neutralizes the latent acidity due to basic salts. The amount of alkali necessary is determined from the quantity of deci-normal soda solution used in the above experiments. Unless the ore contains a large amount of free acid, the preliminary washing with water may be omitted, the total acidity being determined and reported in terms of lime.

**Test for the Consumption of Cyanide.**—The original strength of the stock solution being known, it is only necessary to determine its strength after it has been used on a lot of ore to arrive at the consumption. Introduce 20 grams of ore into a glass-stoppered bottle, and, after treating for acidity if necessary, add 40 c.c. of the regular cyanide leaching solution; next agitate for thirty minutes and filter; measure off 20 c.c.

of the filtrate and determine the amount of undecomposed cyanide remaining in the solution. The difference between the amount of potassium cyanide in 20 c.c. of the regular leaching solution and the quantity found gives the amount consumed by the 20 grams of ore. If the consumption of cyanide is not excessive, or say not over .002 part by weight of the ore, the extraction tests can be continued; if more than this amount, the ore must be rich, in order to stand the expense of the heavy consumption.

**Tests for the Percentage of Extraction.**—Two series of tests are to be made in this case, one by agitation and one by percolation.

*Agitation Test.*—Take four wide-mouthed glass-stoppered bottles, and place 1 assay ton (29.166 grams) in each, then add 60 c.c. of the following cyanide solutions:

To No. 1,	0.1	per cent KCN solution.				
“ “	2,	0.3	“	“	“	“
“ “	3,	0.5	“	“	“	“
“ “	4,	0.75	“	“	“	“

The bottles should not be too large, say 5-ounce bottles, and before the solution is added the correction for acidity should be made as explained. Allow the bottle to stand forty-eight hours, with occasional shaking, and then filter off the solution; wash with

water up to original bulk; test an aliquot portion of the solution for loss of cyanide; dry the tailings; crush them to 100-mesh, and assay. From the assay of the original pulp and the assay of the tailings the percentage of extraction can be calculated.

Another method preferred by some is to assay the tailings and also assay the solution; then

$$\text{Percentage of Extraction} = \frac{\text{Assay of Solution} \times 100}{\text{Assay of Solution} + \text{Assay of Tailings}}$$

For quick results, the bottles are placed in an agitator which is revolved for twenty-four hours.

Several agitation tests can be carried out in this manner, varying the strength of the cyanide solutions and using 10-, 20-, 30-, and 40-mesh ores.

*Percolation Tests.*—For these tests a glass percolating-jar provided with a false bottom covered with a double filter-paper will be found convenient. Such an apparatus is shown in Fig. 1. Place 1 pound, or more, of the pulp (with the proper quantity of the neutralizer thoroughly mixed with it) on the filter, and add to the charge 230 c.c. of the regular leaching solution for each pound of ore taken. Allow the solution to remain in contact with the ore for twelve hours, and then percolate for forty hours, by pouring the solution back in the percolating-jar from time to time.



Wash with water until the filtrate reaches the original bulk.

Test the solution for the loss of cyanide; assay a portion of the solution and the tailings, and thus deter-

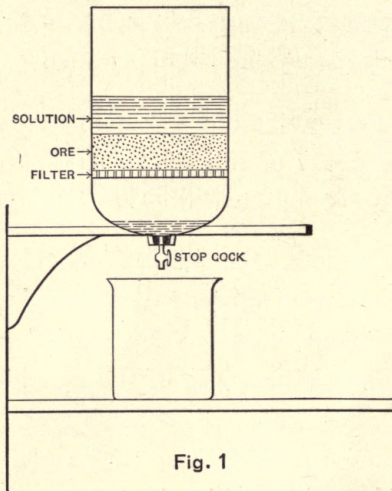

Fig. 1

mine the percentage of extraction. The tailings must be assayed in the dry way.

Carry out a series of tests in this manner, varying the strength of the cyanide solution, the fineness of the ore, and the time of contact from twelve to seventy-two hours.

The results of these experiments will prove whether the ore is suitable for the process, and, if so, the strength of the solution and size of the screen which

will furnish the best extraction in the shortest time with the least consumption of cyanide.

The following formula is given by Furman\* for convenience in calculating the percentage of extraction:

$$d = 6.43016 \frac{b}{ac}.$$

$a$  = the assay value of the ore in ounces troy per ton  
of 2000 pounds avoirdupois;

$b$  = milligrams of gold found in filtrate;

$c$  = pounds avoirdupois of ore taken for the test;

$d$  = percentage of extraction.

**To Make up Cyanide Solutions.**—The working solution, called the stock solution, is made up by placing solid cyanide of potassium in water. This solution in passing through the leaching-vats loses a percentage of its strength, which, however, is made up by the addition of cyanide of potassium.

Commercial cyanide is seldom pure, and it is therefore necessary to use a greater quantity than if it were.

Suppose the KCN is 85 per cent pure; then  $\frac{100}{85} = 1.176$  pounds of the KCN is required to bring the standard up to 100 per cent pure.

One pound of pure KCN dissolved in 100 pounds of

---

\* Furman's "Manual of Assaying." John Wiley & Sons.

water makes a 1 per cent solution; consequently if the KCN is but 85 per cent pure it will require 1.176 pounds to make a 1 per cent solution.

If a vat contain 100 cubic feet of water, and it be desired to make up a solution to 0.5 per cent from KCN 85 per cent pure, the quantity required can be found as follows:

$$100 \text{ cu. ft.} \times 62.5 \text{ lbs.} = 6250 \text{ lbs. water.}$$

If 100 pounds water require 0.5 pound pure KCN, then it will require  $1.176 \times 0.5 = .5880$  pound of 85 per cent pure KCN, and by proportion

$$100 : 6250 = .588 : 36.75 \text{ lbs. KCN.}$$

Suppose the solution to have passed through the leaching and precipitating processes and had run down from .5 per cent to .2 per cent, how much additional KCN must be added to regenerate the solution?

$$100 : 6250 = 0.3 : 18.75 \text{ lbs. pure KCN}$$

and

$$18.75 \times 1.176 = 22.05 \text{ lbs. 85 per cent KCN}$$

would be required.

**Stock Cyanide Solutions.**—To make up stock solutions the quantity of water in the tank must be known, and this is found in tons as follows:

Radius of tank in feet squared  $\times 3.1416 \times$  depth in feet = cubic feet; cubic feet of water  $\times 62.5$  lbs.  $\div 2000$  lbs. = tons of water. Suppose the solution contained .3 per cent KCN; then pounds of water  $\times .3 \div 100 =$  pounds KCN. Suppose .15 per cent KCN was left after leaching; then pounds of water  $\times .15 \div 100 =$  KCN left, and the difference between the .3 per cent and .15 per cent calculations will give the fresh KCN to add.

**Strong Solutions** may contain from .3 per cent to .7 per cent KCN. Suppose it is desired to make 20 tons of .5 per cent KCN solution from a sump solution containing .35 per cent KCN, and the liquor in the stock tank used for strengthening contains 20 per cent KCN. The quantity of liquor required from the stock tank may be found as follows:

$$\frac{20(.5 - .35)}{20 - .5} = .16 \text{ tons or } 320 \text{ pounds.}$$

**Determination of the Free Potassium Cyanide in a Solution.**—Several methods have been suggested for this purpose which give good results.

A rapid and accurate determination may be made by titrating a measured quantity of the solution to be tested with a standard solution of silver nitrate. Silver cyanide is formed and immediately redissolves in the



excess of potassium cyanide. The reaction is as follows:

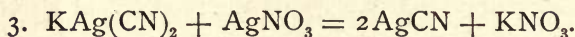
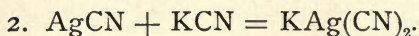
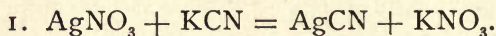

The end reaction is reached when a permanent white precipitate of silver cyanide is produced. When silver nitrate is first added to a solution of potassium cyanide a precipitate of silver cyanide is formed which dissolves in the presence of any free potassium cyanide. The silver nitrate is added until all of the potassium cyanide has united with the silver cyanide to form a double salt of potassium silver cyanide. If more silver nitrate is added than is required to form the double salt, a permanent precipitate is formed of silver cyanide, which shows sufficient silver nitrate has been added for the reaction.

The end reaction is more distinct when two or three drops of a 5 per cent solution of potassium iodide is added to the cyanide solution before titration. After all the cyanide is converted into the double salt any excess of silver nitrate will unite with the potassium iodide to form a precipitate of silver iodide.

**Standard Silver Nitrate Solution.**—A convenient standard solution is one that contains such an amount of silver *nitrate* in each cubic centimeter that when it

is added to 10 c.c. of a cyanide solution before a permanent precipitate is produced it represents 0.1 per cent of potassium cyanide.

**Preparation of the Standard Silver Nitrate Solution.—**

Take 13.06 grams of silver nitrate and dissolve it in 1 litre (1000 c.c.) of distilled water.

**Titration.—**1. Fill the burette with the standard silver nitrate solution.

2. Fill another burette with the cyanide solution to be tested.

3. Run into a beaker 10 c.c. of the cyanide solution and add 25 c.c. of distilled water; add from the silver nitrate burette cautiously silver nitrate solution until a permanent opalescent precipitate remains after thoroughly agitating the solution; two or three drops of a solution of potassium iodide added to the beaker when the cyanide solution is added will assist in determining the end reaction.

4. Read the number of c.c. of standard silver nitrate used and divide by 10; the result is the available potassium cyanide in the solution in per cent.

To illustrate:

If 10 c.c. of the cyanide solution were used and it took 6 c.c. of standard silver nitrate, then  $\frac{6}{10} = 0.6$  per cent KCy.

If a strong cyanide solution is being tested, 3 or 4 c.c. can be used for the titration with silver nitrate.

If 4 c.c. required 6 c.c. of silver nitrate, then 10 c.c. of cyanide would require 15 c.c. of standard silver nitrate; and 15 divided by 10 = 1.5 per cent potassium cyanide.

In testing the strength of the strong solution in the dissolving-tank, take 10 c.c. of the strong solution and dilute with water to 100 c.c. Take 10 c.c. of this solution and titrate with silver nitrate as described above. The number of c.c. of silver nitrate solution required will be the per cent of potassium cyanide in the strong solution, for the 10 c.c. of the dilute solution only contained a tenth of the original cyanide solution, hence there is no need of dividing by 10.

**Determination of the Free Hydrocyanic Acid in Solution.**—To 10 c.c. of the mill solution add 10 c.c. of a solution of potassium bicarbonate (containing 15 grams of  $\text{KHCO}_3$  to the liter), dilute to 65 or 70 c.c. and titrate without the use of potassium iodide as an indicator. Upon the addition of the bicarbonate the following reaction takes place:

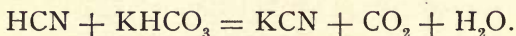

The titration gives the HCN in terms of KCN, and  $\text{KCN} \times 0.415 = \text{HCN}$ . As this titration gives the potassium cyanide and the hydrocyanic acid, the difference between this result and that obtained, multiplied by 0.415, gives the hydrocyanic acid.

For each c.c. of mill solution taken 1 c.c. of the potassium bicarbonate solution is used. This will be sufficient for solutions containing as much as 0.4 per cent of HCN, which is much higher than mill solutions usually run, but the excess does no harm.

The addition of the bicarbonate solution usually causes a distinct turbidity, which should disappear when the solution is diluted, giving a clear liquid for titration. If, as rarely happens, a faint turbidity remains, a duplicate of the solution to be titrated is prepared, the end point being shown by the increased cloudiness in the titrated solution as compared with the blank solution.

**Determination of the Total Simple Cyanides in Solution.**—To 10 c.c. of the mill solution add 10 c.c. of half-normal sodium hydrate solution (20 grams of NaOH per liter), dilute to 65 or 70 c.c.; add a few drops of the potassium iodide solution, and titrate to pale yellow opalescence. The result is the total KCN, HCN, and  $K_2Zn(CN)_4$ , in terms of KCN. The amount of sodium hydrate to be added depends principally on the percentage of  $K_2Zn(CN)_4$  present, as a large excess should be avoided. The amount given will be sufficient for solutions containing 0.7 per cent zinc and 0.4 per cent hydrocyanic acid, and will answer in all ordinary cases likely to be encountered in mill practice. The addition of the





sodium hydrate produces a permanent precipitate, but the use of potassium iodide as an indicator prevents any doubt as to the end reaction.

**Determination of the Ferro-, the Ferri-, and the Sulpho-cyanides in Solution.**—The ferrocyanides and the sulphocyanides, if desired, may be determined by titration with a standard solution of potassium permanganate in an acid solution, the reactions being as follows:

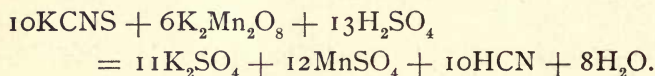
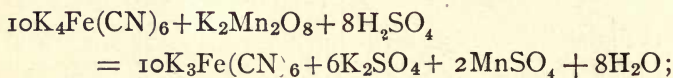

One portion, acidified with sulphuric acid, is titrated, the result representing both of the above compound cyanides. To a second portion, acidified with sulphuric acid, a solution of ferric chloride is added. The resulting Prussian blue is filtered off and the filtrate is titrated with the standard permanganate solution. This second titration gives the potassium sulphocyanide.

The permanganate solution should be quite dilute, containing not more than from 0.3 to 0.5 grams of potassium permanganate to the liter. It may be standardized by any of the approved methods, and its value

may be calculated for the compound cyanides according to the above equations.

Ferricyanide, if present, may be determined by reducing it to ferrocyanide, and then by titration with standard potassium permanganate as above.

Should sulphides be present, the shaking up of the solution with moist lead carbonate will produce a black precipitate of lead sulphide. When present, they must be thus removed, by agitation with lead carbonate and filtering off the resulting lead sulphide, before the compound cyanides can be determined.

**Assay of Cyanide Solutions for Gold and Silver.**—(1) Evaporate 29.2 c.c. of the solution to dryness in a lead tray. Roll up the lead and cupel, weighing resulting button. Alloy the bead with silver if necessary, and part the gold with nitric acid in a porcelain capsule.

Should the solution contain over 0.2 ounce of gold per ton, the lead should be scorified together with a little borax glass prior to cupellation. The lead tray is made of pure lead-foil. It is about 3 inches long, 2 inches wide, and  $\frac{1}{2}$  inch deep, and should weigh about 20 grams. The tray or boat is placed on an asbestos cardboard, that rests on a tripod and has a Bunsen burner underneath.

(2) Evaporate  $\frac{1}{2}$  pint of solution to small bulk; add 40 grams litharge and evaporate to dryness; transfer

to clay crucible and add 14 grams pulverized glass, 7 grams soda, and 3 grams argol. Cover with borax, fuse, pour, and cool. Cupel lead button; weigh and part for gold with  $\text{HNO}_3$ ; weigh.

(3) *Crosse's Method*.—Add nitrate of silver to  $\frac{1}{2}$  pint KCN until precipitate ceases to form. Decant off the clear solution; filter and dry precipitate. Mix with 4 grams litharge, 7 grams powdered glass, 7 grams soda, and 3 grams argol. Fuse in crucible; pour and cupel lead button. Flatten button and part without weighing. Weigh resulting gold. This method will not give silver, but is accurate for gold.

**To Test the Strength of Cyanide Solutions by Iodine Solutions.**—(1) This method depends on the fact that when a solution of iodine is added to one of potassium cyanide, the iodine loses its color so long as any undecomposed cyanide remains.

(2) *To Make up Standard Iodine Solution*.—Use the reaction  $2\text{I} + \text{KCN} = \text{KI} + \text{ICN}$ . 254 saturates 65, and  $25.4 = 6.5$  in a decinormal solution.

Therefore, to make a standard solution, weigh out 25.4 grams of iodine, place in a beaker with 200 c.c. of water, and add sufficient potassium iodine to completely dissolve the iodine with frequent shaking. When the iodine is dissolved make up to 1000 c.c. with pure water, and place in a stoppered bottle. Then 1 c.c. = .0065 gm. KCN.

(3) *The Actual Determination.*—(a) Fill a burette with standard iodine.

(b) From another burette measure off 6.5 c.c. of cyanide solution to be tested, and to this add carbonic acid (20 c.c. of ordinary soda-water will do) to convert the caustic and mono-carbonate alkalies, contained in all commercial cyanide, into bi-carbonates.

(c) Now run in standard iodine, cautiously and slowly, until a slight but permanent yellow color is produced.

(d) Read off the number of c.c. of standard employed, divide by 10, and the result will be the percentage of KCN required.

*Remarks.*—This method does not give reliable results in the presence of sulphides or when the cyanide solution is muddy or discolored.

**To Test the Strength of Cyanide Solutions by Silver Nitrate Solutions.**—The reaction is as follows:

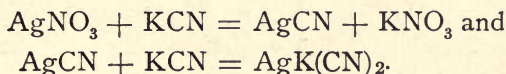

Making up the standard solution from the molecular weights, it will be found that 17 grams  $\text{AgNO}_3$  will saturate 13 grams KCN; thus

$$\text{Molecular weight of AgNO}_3 = 170 = 17.$$

$$\text{Molecular weight of 2KCN} = 130 = 13.$$

If, therefore, 17 grams  $\text{AgNO}_3$  be dissolved in 1000



c.c. or 1 liter of pure water, 1 c.c. will be equal to .013 gram KCN.

This is a decinormal solution, and to avoid mistakes in calculations dissolve 13.07 grams of silver nitrate in 1000 c.c. of pure water, because  $17 : 13 = 13.07 : 10$ .

To test a cyanide solution take 10 c.c. and titrate with silver nitrate, then divide by 10, and the result will be the percentage of potassium cyanide in the solution.

For example, if 10 c.c. required 8 c.c. of silver nitrate,  $8 \div 10 = 0.8$  KCN in the solution being tested.

## CHAPTER V.

### THE PLANT FOR CYANIDING.

**The Process.**—Briefly the cyanide process consists in treating suitable raw ores, roasted ores, concentrates, slimes, or tailings in vats by solutions of potassic cyanide. The ore previous to treatment must be crushed, sometimes very fine and sometimes to not more than half-inch pieces, depending upon its porosity.

Tailings or concentrates have been previously crushed, and need only be conveyed to the vats for treatment.

Slimes are the result of crushing, and are not sought in the process; nevertheless when rich they are to be saved and subjected to special treatment.

If amalgamation is practised, the tailings may be conveyed directly to the leaching-vats; but as from three to five gallons of water per minute are used in stamp-milling, they had better be conveyed to a settler and the battery-water drained off. This will also remove a portion of the slimes.

After the ore is placed in vats it is subjected to pre-

liminary treatment if necessary, and if not, the cyanide solution is turned into the vat, when leaching commences at once. After the cyanide has dissolved the gold from the ore, the solution is drained from the vat and allowed to circulate by gravity, at least in most instances, through the MacArthur-Forrest zinc-precipitating boxes, where the gold is precipitated on the zinc and from which it is recovered to be refined. The solution of cyanide by the time it leaves the zinc-precipitation boxes has become impoverished, for which reason it is drawn off into sump-tanks, and there pumped into storage-tanks, where it is strengthened as desired by the addition of potassic cyanide. Not more than 50 cents' worth of gold should remain in the solution after it leaves the zinc-boxes.

**Location for a Plant.**—Wherever possible, the plant should be so arranged that advantage may be taken of gravity, as this will do away with elevating machinery and much pumping. However, in some instances this is not possible and the plant is built on comparatively level ground. Some of the largest plants are arranged in the latter way from necessity.

A simple arrangement is shown in Fig. 2, in which *a* are the leaching-vats; *b*, the zinc-boxes for precipitating the gold, with the boiler- and pump-house under the same roof; *c*, the sump-tank for the exhausted solution and which, on account of the smallness of the plant,

is also the storage and regenerating tank; *d* is the trestle passing over the leaching-tank, and from which the ore is charged from tram-cars into the tank; *e* is the tailings-track, for cars into which the exhausted tailings are loaded and trammed to the dump. The dotted lines represent the pipe-lines from the leaching-vat to the zinc-boxes and then to the sump-tank. The dotted line from the bottom of the

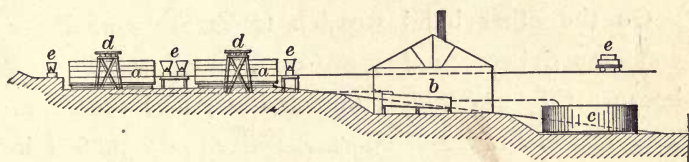

Fig. 2

sump-tank is the tail-pipe of the pump which draws liquor from that tank and pumps it up to the leaching-tank.

**The Leaching-vat.**—These vats are made of pine or spruce, steel or iron California, redwood or Louisiana cypress. Vats should be painted with asphalt or some other non-metallic and water-proof paint. This is not absolutely necessary in the case of wood, but is for steel and iron if they are to be preserved. In some instances vats have been made of masonry with an inside coating of cement. Masonry vats are not, however, generally approved, on account of the inability to detect leaks and their extra expense over wooden



vats. The Pelatan-Clerici vat is made of wood, lined inside with cement. It may be possible in case cement linings are used to set up chemical action, especially with acid ores and faulty cement. Wooden tanks lined with cement would leak in case the cement became cracked or injured, because of the impossibility of keeping wooden tanks tight when not swelled by water.

On the other hand wooden tanks are sometimes condemned because they are constructed poorly, and because they are said to absorb the gold in solution. The vats are made of enormous size up to 50 feet in diameter, and must therefore be placed on strong masonry, for such vats will hold many tons of ore and water.

Rectangular tanks are sometimes used, but there is difficulty in maintaining tight joints with such tanks; nevertheless the largest cyanide plant in the United States has rectangular tanks  $25 \times 50 \times 5$  feet. Owing to the difficulty in keeping rectangular wooden tanks from leaking, round wooden tanks have been generally adopted. These are kept water-tight by numerous round iron bands, provided with lugs at each end through which a bolt is passed and tightened with a nut, as shown in Fig. 3. It will be found cheaper in every instance to purchase tanks direct from the makers, in knock-down form for transportation, than

to build them, and consequently it is not thought necessary to go into details of tank construction. The writer has had considerable experience with home-made and manufactured wooden tanks, for which reason he recommends the latter to prospective tank users. It stands to reason that one who is engaged in the manufacture of tanks as a business is equipped for the purpose with machines which make each part

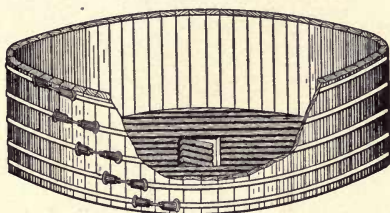

Fig. 3

as nearly true as possible, something the carpenter cannot accomplish but can approximate. In regard to the manufacture of iron tanks the same applies, and hence the details of construction are omitted.

**Filter or False Bottoms.**—Filter-frames are shown in the bottom of the tank in Fig. 3, the side being cut away for that purpose. The old gravel-bed filter has been entirely discarded in modern leaching practice for such frames, which are built in sections for large vats. In such vats the floor slopes gently towards the center in order to facilitate drainage, and wooden frames are placed as shown at *a*, Fig. 4. The floor-slats are

notched at intervals to permit the solution to circulate freely. Upon these slats strong canvas, cocoa-matting, or burlap is stretched and fastened in, by leaving a space for the purpose between the frame and the inside periphery of the tank. The canvas having been

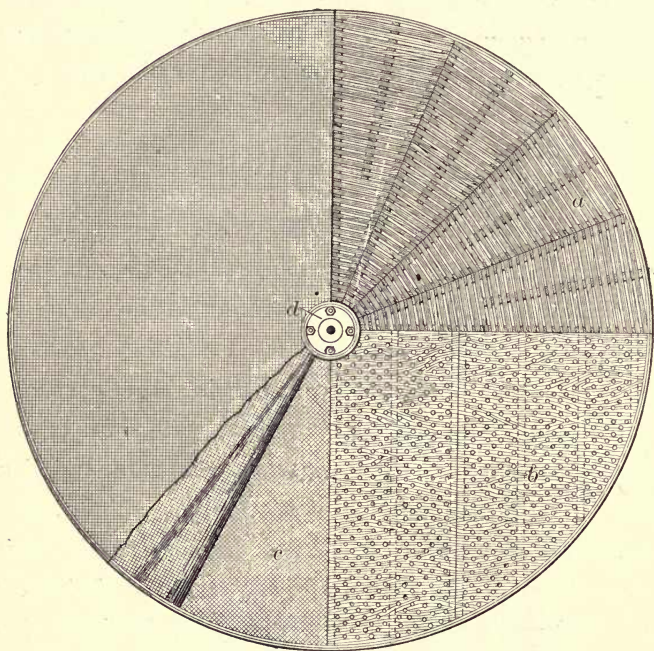

Fig. 4

stretched, a rope is driven into the space mentioned, which holds the cloth taut and prevents the ore running into the bottom of the tank. In large or deep tanks there would be too much strain on the

canvas, for which reason the perforated boards shown at *b* are placed over the slats *a*, and upon these the canvas *c* is laid. The flange *d* is either for a bottom discharge-valve worked from the top of the tank, and through which the tailings are run off, or for a vacuum filter-pump which assists drainage.

**Ore Discharging.**—Wherever possible and there is plenty of water it is economical to sluice the tailings out of the vat through doors in the side or in the bottom. In case there is to be

side discharge, the door shown in Fig. 5 is a fairly good pattern. The door-frame is fastened to the tank by bolts and nuts, but between it and the side of the tank sheet-rubber

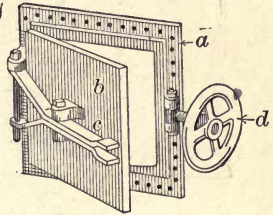

Fig. 5

gaskets are placed, thus obtaining a water-tight joint. The door *b* is provided with a yoke *c*, that engages when it is closed with the latch *d*. The latch is provided with a thread upon which the large hand-wheel nut works to complete the fastening. There are other side-discharge gates, but the one illustrated is as simple and serviceable as any. Where such gates are used there should be at least two to the tank.

In Fig. 6 is shown the butterfly valve, for bottom discharge. Where water is scarce or the tailings are



shovelled out of the tank several such valves will be required. The valve shown is known as Butters' valve. When in place it extends up through the vat floor and through the filter, so that it in no way interferes with

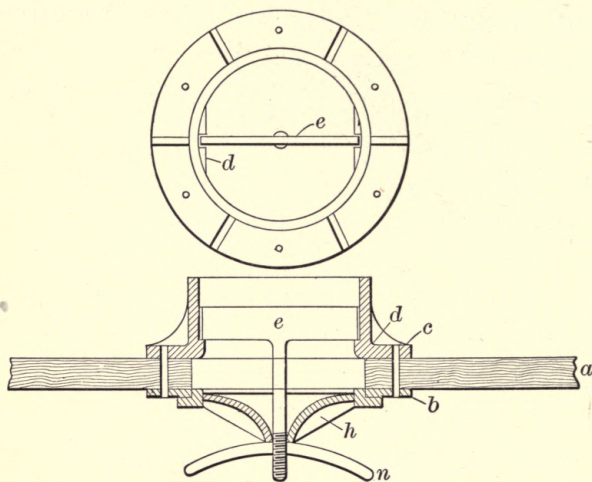

Fig. 6

percolation. In the cut *a* is the tank bottom, *b* a plain iron flange which is bolted to a cast-iron nipple *c*, having a flange to correspond with *b*, and a shoulder *d* on the inner side upon which the hanger *e* rests. This hanger is provided with a screw-thread and a nut *n* for tightening the cover *h*. The nipple or cylinder is about 2 feet in diameter, thus affording ample room for the discharge of tailings.

In some instances the tailings are shovelled over the

sides of the vats into tram-cars; in others, for instance at the Langlaagte Cyanide Works, near Johannesburg, South Africa, the car-bodies are raised from their trucks by cranes and lowered into the tanks, loaded and raised out to the trucks by the same contrivances. In other instances the tailings are kept sufficiently wet to permit of their being drawn out through the tail-pipe of a centrifugal pump.

The different arrangements are mentioned here because the locations of cyanide plants must necessarily vary. Where water is plentiful and there is sufficient fall to the tailings-dump, sluicing is to be preferred, but even in this case drainage after the dump is reached must be considered, for prussic acid in very small quantities is not at all healthy for animals or individuals.

At several cyanide works in New Zealand where there is a percentage of coarse gold the tailings are slowly sluiced over amalgamated plates in order to save as much gold as possible. The plates are said to be quite expensive, and the recovery seems to warrant their continuance.

**Vat-filling.**—The methods employed for filling vats with ore are as numerous as the methods of discharging. In some instances where the ore is dry it is conveyed to the tanks by belts or trough conveyors, the latter sometimes of the screw type, sometimes of the

flight type, and again of the bucket type. These belt- and scraper-lines can be applied with economy and advantage in many cases, so long as the pulp is not too wet, although they have not been generally adopted, probably from the fact that they do not distribute the pulp over the vat. The idea of pulp distribution originally was obtained from chlorination practice, where, if it was not loosely and evenly sifted into the vat, the gas could not work up through it; but in cyanide practice a liquid is being used and there is not the necessity for such nicety of distribution, especially when the solutions are admitted either from above or below but are drained from below. It would appear, then, that vats could be filled with conveyors equally as well as from cars, and could assist in the distribution in large tanks to a greater extent than tram-cars. At some works, to avoid dust, the ore is dampened or soaked outside the leaching-vat, and at others it is washed of acids and neutralized in tanks before being charged into leaching-vats; again at other plants it is soaked with cyanide solutions before being placed in the percolating-vats. This modern practice changes the entire complexion of affairs so far as vat-charging is concerned, and opens up a field for economy by the use of conveyors for the purpose.

Where tailings from stamp-mills are to be charged into vats, they are generally settled and the slimes

washed off. The sands are then washed into the leaching-vats and the excess water drained off into launders. In such cases the slimes are settled and, if valuable, treated separately. This method is practised largely in South Africa, where amalgamation precedes cyaniding and the ore is stamped wet.

In what is termed intermediate filling the tailings are run direct into tanks, where the sands settle and the slimes float away. From these settling-vats the tailings are distributed to the leaching-vats. When the slope of the ground permits they are run into the leaching-vat from a hole in the bottom of the settling-tanks.

Messrs. Butters and Mein devised a simple reaction-wheel, on the principle of the lawn-sprinkler, which is effective in evenly distributing the pulp and besides, on account of the commotion it causes, keeps the slimes floating until they are washed over the sides of a tank into a launder. The pulp running out of a series of arms causes the wheel to revolve in the opposite direction from which the pulp discharges. The overflow of slimes is continued until the vat is full, and clear water is still supplied until they have all been removed.

**Water Required for Leaching.**—The arrangement of a 75-ton cyanide mill is shown in plan in Fig. 7 and in elevation in Fig. 8. By reference to the figures it will be seen that there are storage-tanks, gold-solution



tanks, sump-tanks, settling-tank, and acid-tank. In some instances there are stock-tanks where strong cyanide solutions are kept to strengthen the standard solution as they are pumped from the sump-tank to the storage-tanks.

It will be noticed that the solution-tanks are of less size than the leaching-vats, the reason being that the latter must contain ore as well as solution. Fine-crushed ore will occupy about 28 cubic feet of space to the ton, while a ton of water will occupy 32 cubic feet. Easy-flowing siliceous pulp will require 80 gallons of water per ton of ore; heavy concentrates, about 120 gallons per ton of ore; the wash-water required is about 140 gallons per ton of ore. In lixiviating 80 gallons per ton of ore should be counted on for solutions, and 140 gallons per ton of ore for wash-water.

Slimes will retain 240 gallons of water; tailings, 30 gallons per ton. The loss from evaporation and all sources will be about 25 per cent of the water used when care is taken to save it for future use.

**Vat Foundations.**—The foundations for vats must be strong, preferably of masonry, but in case that is not feasible strong bents must be used and these must be level and, if possible, placed upon masonry, or at least concrete. Wooden vats when charged with ore and solution are heavy, and if not placed on solid and level foundations will rack and leak. This is due in a

measure to the chimes in the staves necessary to keep the wooden bottoms in place and make tight joints. Large leaching-vats are now made about 5 feet deep.

**Precipitating-boxes.**—The box shown in Fig. 9 is the most common in use. It consists of nine compartments about  $12 \times 18$  inches inside and 20 inches deep, made of 2-inch plank outside and  $1\frac{1}{4}$ -inch plank for compartments. The box is held together by bolts and is coated inside and out with paraffine-paint. The boxes are given a slight slope to assist the movement of the gold solution which enters the first compartment at *a*, then up and over the partition *b*, into the second compartment at *c*, and so on up and down to the final discharge at *d*. In the last compartment zinc shavings are shown resting on a screen: these shavings are in all the compartments through which the solution circulates. The pipes shown in the bottom of each compartment are for the purpose of drawing off the precipitates and the liquor left in the box when it is desired to clean up. Another arrangement for the same purpose is to have a launder on the side, covered and locked so that the precipitates cannot well be stolen. Boxes are sometimes made small and arranged in series, but there is little advantage to be derived from this, while they are more expensive to install and offer more opportunity for leakage. About 50 pounds

of zinc shavings are required to fill a box of the size shown in the figure.

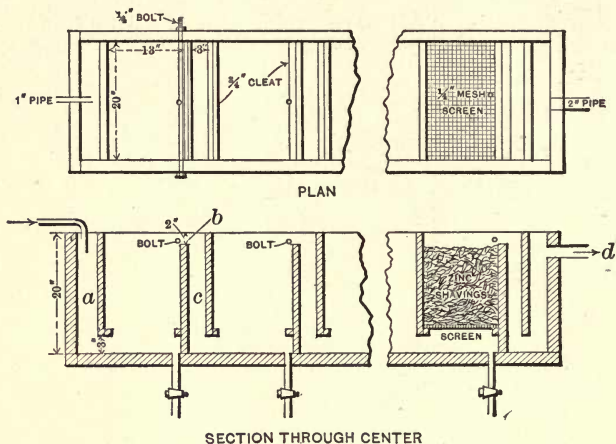

Fig. 9

The settling- and acid-tanks are used for treating the gold slimes, and will not be more than mentioned here.

**Vacuum-filter.**—The rate of drainage is very slow, ranging with some ores from  $\frac{1}{2}$  to 1 inch per hour. A vat 4 feet deep would require at this rate from 96 to 48 hours to discharge. For this reason the treatment of slimes and clayey ores is impracticable in the process now being described. Percolation may be hastened by creating a vacuum under the filter by means of an air-pump or an injector, and these machines are generally used. There is an objection to the injector, although it does its work fairly well;

nevertheless it weakens the solution by the amount of steam condensed in working, since all steam passes into the solution.

**Pipes.**—The solutions are pumped and drained through wrought-iron pipes. The pipes for charging the vats with solutions vary from  $2\frac{1}{2}$  inches for a 20-foot-diameter vat to 4 inches for a 40-foot-diameter vat.

These pipes have three valves, so that they may receive strong or weak solutions, and be drained by a third valve when that is necessary. The drainage-pipe has a short nipple to which is attached a piece of rubber hose in order to drain off weak solutions and keep them separate from the strong solutions and *vice versa*. This is done by having double launders passing in front of each tank, one compartment of which leads to the strong gold-solution tank and the other to the weak gold-solution tank. There are usually two lines of pipe leading to the leaching-vats from the solution-tanks, one for weak and the other for strong solutions. There are also weak and strong solution sump-tanks, the object being to pass the strong gold solutions through a series of tanks, filter-boxes, and sumps back to the strong solution storage-tank, and also follow the same method with the weak solutions. In case of the vacuum-discharge the nipple and hose are not used; the vacuum-pump drains the strong or weak gold



solutions from the vats and discharges them into their respective tanks.

A centrifugal pump lifts the solutions from the sump-tanks and discharges them into the storage-tanks. A special launder is used for conveying the gold slimes from the filter-boxes to the acid-tank, where they receive special treatment before refining. This launder is sometimes made movable, and connects with the clean-up launder, previously mentioned, on one side of the zinc-box.

**Plan of 75-ton Cyanide Plant.**—Fig. 7 shows the plan of a 75-ton cyanide plant, and Fig. 8 an elevation of the same plant.

There are two storage-tanks, *a*, 12 feet in diameter and 10 or 12 feet deep; four leaching-vats, *b*, 25 feet in diameter and  $4\frac{1}{2}$  feet deep; two gold-solution tanks, *c*, 12 feet in diameter and 6 feet deep; two sump-tanks, *d*, 12 feet in diameter and 6 feet deep; five zinc-boxes, *e*, three for the strong solutions and two for the weak solutions; each box has nine compartments  $24'' \times 18'' \times 15''$ . The pipes can be traced to their different destinations and therefore do not need explanation. The launder *f* has a double compartment; the launders *g* have a single compartment, as do the launders *h* and *i*. The vacuum-pump is at *s*, the centrifugal pump at *w*; the power for running these pumps is situated at *p*. The laboratory is at *l*, and



solutions from the vats and discharges them into their respective tanks.

A centrifugal pump lifts the solutions from the pump tank... special launders... from the filter-box... to the acid-tank... here they receive special treatment... before returning to the filter-box... is sometimes made movable, and comes into contact with the clean-up launders previously mentioned... on the side of the zinc-box.

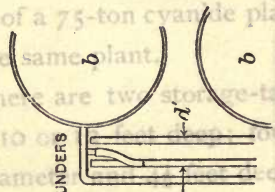
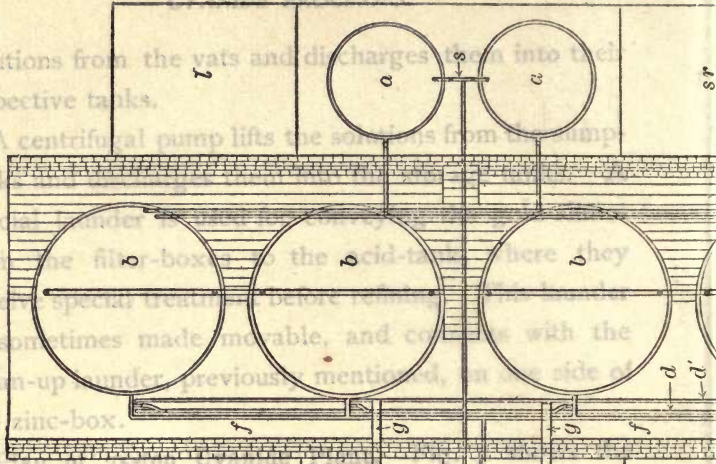

plan of a 75-ton cyanide plant, and 1/2 elevation of the same plant.

There are two storage re-tanks... and 10... in diameter... 4, 12 feet in diameter and... d, 12 feet in diameter and... e, three... for the strong... solutions; each box has 18" x 15". The pipes... destinations and therefore... The launder f has a... launders g have a single... launders h and i. The... centrifugal pump at w; the... pumps is situated at p.

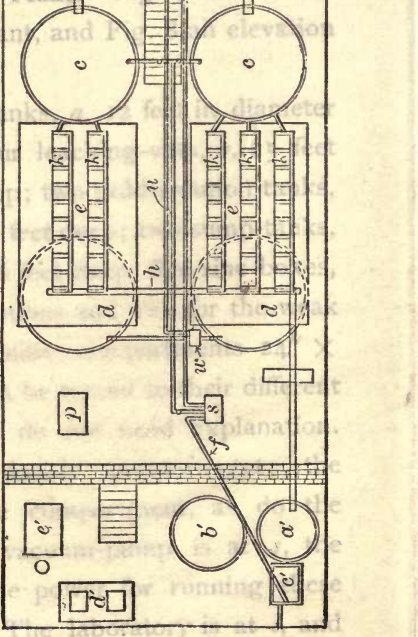

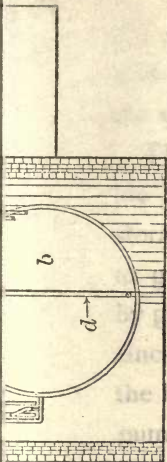

Fig. 7

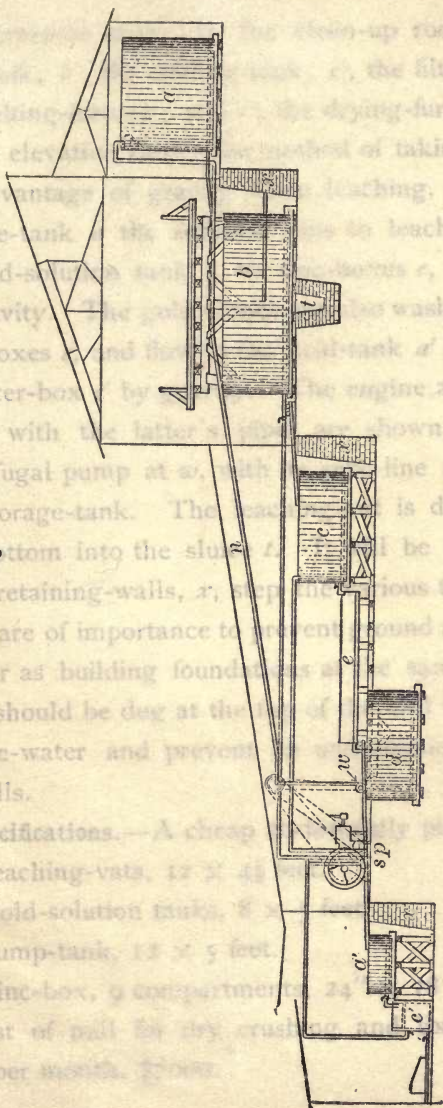

Fig. 8

[To face page 70.]

the elevating apparatus of taking a pump advantage of the water in the leaching. From the large-tank the solution goes to leaching-tank A, by gravity. The solution is then washed from the zinc-boxes and flows into leaching-tank A' and then to the filter-box by the engine and vacuum-pump with the latter's discharge shown at *sp*, the centrifugal pump at *w*, with the discharge line *n* leading to the storage-tank. The solution is discharged at the bottom into the slurry tank. It is to be noticed that good retaining-walls, *x*, step into the faces, and these are of importance to prevent ground run-ways, and answer as building foundations at the same time. A ditch should be dug at the surface of the ground to prevent surface-water and prevent the water from running or walls.

Specifications.—A cheap  
 4 leaching-vats, 12' x 4'  
 2 gold-solution tanks, 8' x 4'  
 1 sump-tank, 12' x 5 feet  
 1 zinc-box, 9 compartments, 24' x 15' x 15"  
 Cost of mill for dry crushing and leaching 600 tons per month, \$2000.



[The views are of the]

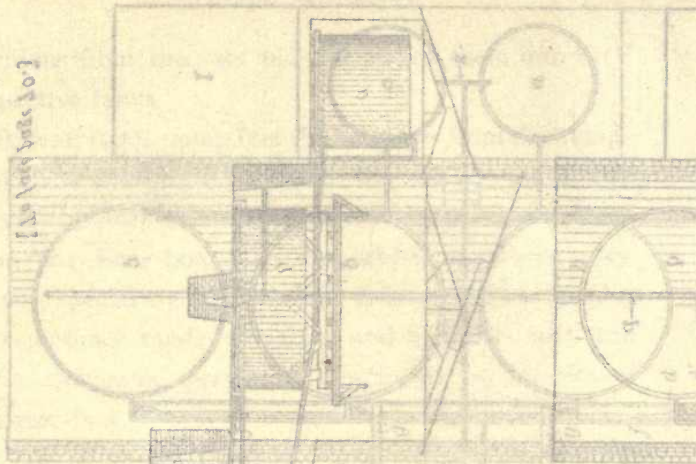
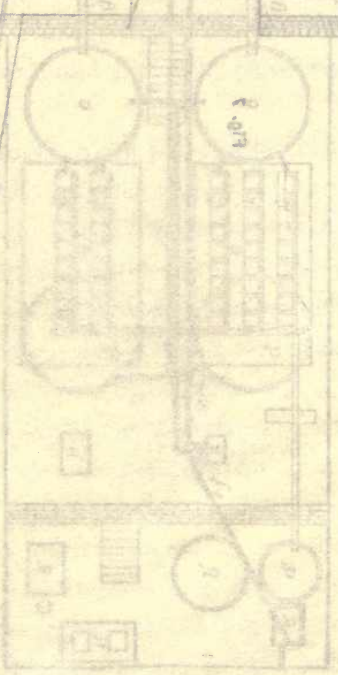

Fig. 8



the storeroom at *sr*. In the clean-up room *a'* is the acid-tank; *b'*, the settling-tank; *c'*, the filter-box; *d'*, the melting-furnace; and *e'*, the drying-furnace.

The elevation shows the method of taking all possible advantage of gravity when leaching. From the storage-tank *a* the solution runs to leaching-tank *b*, to gold-solution tank *c*, to zinc-boxes *e*, to sump *d*, by gravity. The gold slimes are also washed from the zinc-boxes *e*, and flow to the acid-tank *a'* and then to the filter-box *c'* by gravity. The engine and vacuum-pump with the latter's pipes are shown at *sp*, the centrifugal pump at *w*, with its pipe-line *n* leading to the storage-tank. The leaching-vat is discharged at the bottom into the sluice *t*. It will be noticed that good retaining-walls, *x*, step the various terraces, and these are of importance to prevent ground running, and answer as building foundations at the same time. A ditch should be dug at the top of the mill to lead away surface-water and prevent its undermining the tanks or walls.

**Specifications.**—A cheap 20-ton daily plant requires:

4 leaching-vats,  $12 \times 4\frac{1}{2}$  feet.

2 gold-solution tanks,  $8 \times 5$  feet.

1 sump-tank,  $12 \times 5$  feet.

1 zinc-box, 9 compartments,  $24'' \times 18'' \times 15''$ .

Cost of mill for dry crushing and lixiviating 600 tons per month, \$7000.

Cost of mill for treatment of 600 tons tailings per month, \$3000.

A 50-ton-capacity plant, or 1500 tons monthly, requires:

2 storage-tanks, 12 × 8 feet.

4 leaching-vats, 20 × 4½ feet.

2 gold-solution tanks, 10 × 5 feet.

2 sump-tanks, 10 × 5 feet.

4 zinc-boxes, 2 for strong solutions and 2 for weak solutions, each having 9 compartments, 24'' × 18'' × 15''.

Approximate cost of dry-crushing mill, \$10,000.

Mill of same capacity for treating tailings, \$5000.

A 75-ton daily or 2250 tons monthly capacity mill requires:

2 storage-tanks, 12 × 10 feet.

4 leaching-vats, 25 × 4½ feet.

2 gold-solution tanks, 12 × 5 feet.

2 sump-tanks, 12 × 5 feet.

5 zinc-boxes, 3 for strong solutions and 2 for weak solutions, 9 compartments each, 24'' × 18'' × 15''.

Cost for mill of this capacity when dry-crushing the ore, \$15,000. When treating tailings, \$8000.

Specifications for 200-ton daily plant or 6000 tons per month:

2 storage-tanks, 16 × 12 feet.

6 leaching-vats, 35 × 4½ feet.

2 gold-solution tanks, 16 × 5 feet.

2 sumps, each 16 × 5 feet.

7 zinc-boxes, 9 compartments each, 24" × 18" × 15": 3 zinc-boxes for weak and 4 for strong solutions.

Approximate cost of dry-crushing mill of this capacity, \$40,000. For tailings, lixiviation only, \$20,000.



## CHAPTER VI.

### LEACHING THE ORE.

**Agitation.**—The term ore includes any mineral that may be worked at a profit; hence gold ores would include slimes and tailings at times. The original ideas of MacArthur-Forrest were to agitate the ore in the cyanide solution. They suggested no form of vessel or mechanical contrivance, but simply stated that if the pulp were kept in motion by any convenient mechanical stirrer the operation would be hastened.

Nearly every electrical cyanide process is conducted on the lines of agitation. It is conceded that agitation lessens the time of extraction and expedites the process. It allows the oxygen of the atmosphere to act on potassium cyanide in such a way as to unite it with gold and form the double salt auro-potassic-cyanide; it is also probable that by agitation the cyanide can come in contact with the metals more readily; thus the so-called rusty gold, or that encased in a film of oxide or sulphide, upon receiving the slightest scratch that breaks the film will permit the



cyanide to attack it, and so dissolve it in quicker time. Where ores are coarse and porous, agitation would assist the operation, but its great practical use will be found with hard and fine ores. When very low-grade tailings are treated, or fuel is expensive, or where very large vats and ore charges are used, mechanical agitation may prove more expensive than simple percolation.

Ores containing tellurides, arsenides, and sulphides will give better results if agitated than can be obtained by percolation alone. Barrels with arms, similar in construction to chlorinating-barrels, also shafts with radiating arms, have been used for the purpose of agitation. The size of ore-charges treated by agitation is limited to the capacity of the barrels or size of the vats and motive power.

If time be an element of importance, stronger solutions of cyanide may be employed with agitation; but as the loss is proportionally greater, it is the customary practice to use weaker solutions and economize on chemicals. With agitation-barrels it is necessary to introduce chemical oxidizing agents, otherwise no time will be gained, as has been illustrated by MacLaurin's experiments.

The pneumatic process is also one of agitation.

**Leaching with Cyanide Solutions.**—The percolating process is extensively employed for ores, concentrates,

and tailings. The process consists in soaking the ores to be treated with cyanide of potassium solutions. After soaking or leaching, as it is called, the solution is drawn off and another stronger solution is sometimes run on.

The time required for running off or draining these various leaching solutions from the ores depends upon the degree of fineness of the ore and its character for packing tight, which of course would hinder the rapidity of drainage.

Here it can be seen that uniformity of crushing is advantageous, and that the coarser the ore the quicker will be the drainage. The liquor is run into the vat through the bottom by a pipe connected with a vat holding the solutions of various strengths. The solution rises slowly upwards through the ore until it has covered the entire charge of ore in the vat. The object of this upward percolation against gravity is that by this means the solution permeates the mass evenly. The solution is run in slowly to avoid making channels in the ore, which would be disadvantageous to good downward percolation when drainage takes place. The idea is to make the whole quantity of liquor rise and fall through the ore evenly, and not up or down through channels.

When tailings, especially tailings containing clay, are charged into percolating vats, they are apt to

remain lumpy. Cyanide solutions will not thoroughly soak into or penetrate such masses, and as channels will be formed the liquor will naturally go the easiest way through the ore. A mixture of clean sand with the ore will assist percolation in such cases, and this proceeding may be necessary with clean concentrates and slimes, which would pack, unless broken up in this manner, to such an extent that percolation could not occur.

**Preliminary Washing.**—With ores containing sulphates a preliminary washing is necessary, as a partial oxidation of iron pyrites produces soluble sulphates and free sulphuric acid, both of which are sometimes destructive to potassium cyanide. These are washed away by water as much as possible, and the remaining acids and salts neutralized by caustic soda or quicklime. If the ore does not require more than 3 pounds of caustic soda or lime per ton, the preliminary washing may be omitted, for this quantity of alkali will not effect subsequent precipitation when it enters the zinc-boxes with the potassic-cyanide solution which follows the neutralizing process. The sulphate of lime is less soluble than sulphate of soda and hence affects precipitation less; however, it is not readily washed away by water, but may form sufficient potassium sulphide or sulphate to slightly injure the solution or precipitate the gold in solution.



**First Step.**—This may be either the standard leaching solution or a weak solution, depending upon the judgment of the millman. If much potassium cyanide is going to be lost, the solution may be a weak one of such a strength that all cyanicides will be exhausted, and the solution as well, since then it may be run to waste. Percolation experiments have shown that in most cases the solutions will permeate the ore quicker when introduced from below rather than from the top of the vat. In case the strong solution is the one first employed for leaching, the following method is advisable:

**Second Step.** — After preliminary operations have been completed, the ore is soaked with a strong solution, varying, according to experiments made, from .6 to .25 per cent KCN. This allows the solution to penetrate all parts of the tank and establish a uniform density. The solution is now allowed to percolate upwards until the pulp is quite thin, when percolation downwards is commenced, until the solution being used shows, on going out, a loss of two or three points. The ore is then allowed to soak in this standard solution for a length of time which has been determined by laboratory experiments to be suited to the ore.

The strong solution, now the strong-gold solution, is drained off into the gold-solution tanks, and at the same time a weak solution is run on and percolation

continued until the outgoing solution and the weak solution in the tank have the same strength. The solution is allowed to cover the ore in the vat several inches, and after several hours is drawn below the surface of the ore, then allowed to stand this way for one hour, when more solution is added to cover the ore in the vat. There may be a succession of changes of this description, the object being to bring air in contact with the ore and thereby hasten the solution of gold. The time of percolation with the strong solution is usually about twenty-four hours, when it is drained and, as stated, a weak solution run on.

**Third Step.**—As soon as all the strong-gold solution has been drained off, the weak solution, varying in strength from .1 to .3 per cent, is allowed to remain in contact with the ore, after which percolation is commenced and continued until a distinct loss of cyanide in the solution is noticed.

Drainage to the weak-gold-solution tank is now commenced; at the same time the third solution is run on. When the solution leaving the vat shows the same strength as the one entering, drainage is discontinued. In some instances a third leaching solution is not considered necessary, in which case the weak solution is displaced with water until it shows, upon testing, not more than .03 per cent KCN, and the water wasted or used for a preliminary wash. In some cases the ore

is not more than barely covered by the solutions, the object being in such cases to prevent packing by a head of water above the ore; it is, however, advisable to cover the ore at least 2 inches with the solutions.

The strength of the weak solution should not be more than one third that of the strong solution.

**Fourth Step.**—The third solution is also weak, and generally the solution that has passed through the process as the second solution in a previous operation. It will contain not more than 0.1 per cent KCN. This is allowed to percolate the same as the previous solutions and after standing in contact with the ore for several hours is drained off. At the same time it is draining wash-water is turned on until the solution leaving the vat shows no more than .03 per cent KCN.

This solution can be run through the precipitation-boxes, or be kept for use and strengthened to answer as the second or weak solution in the next leaching, the second solution in this case answering as the third solution. That there is any advantage in this interchange of weak solutions is questionable; however, it is claimed by some that where gold is in a solution the extraction is better, and as very little gold is in the third solution, but more than in the second which has gone through the zinc-boxes, the practice may be advantageous.

**Fifth Step.**—In case the wash-water is drained off

from the ore it can be saved to use as the preliminary wash on the next charge. This practice may have the advantage of destroying some cyanicides which would otherwise attack the strong solution. When used as indicated it is run to waste, and in case it is not so used it is wasted; otherwise there would be too much increase in the bulk of solutions. As little water should be used for this purpose as possible, in order to prevent an increase in bulk of solutions.

**Sixth Step** is the precipitation of the gold from solution, but as this is a process by itself it will be treated separately.

The discharge of tailings has been previously mentioned under Ore Discharging.

**Time of Leaching.**—The rate at which the solution percolates through the ore is a question of some importance. If the ore is such that percolation cannot take place at a rate above  $\frac{1}{2}$  inch per hour, the slimes, or whatever it is that packs, must be considered. In the case of clayey ores sand must be added to make a porous bed. In the case of sulphides a similar mixture may be needed, for sulphides may arrange their particles in such order that liquor can barely pass through them. In case slimes are the cause of poor drainage they must be washed from the ore, and run off if poor, or if rich be saved and treated separately.

In some cases, such as clayey ores, it may prove



advantageous to roast them, provided hydraulic cement is not formed.

It is possible that with clayey ores values can only be recovered by the agitation processes.

To prevent packing, the ores are placed in shallow leaching-vats and the solutions are barely allowed to cover them. The time of leaching must necessarily vary with the condition of the ore, and may be hastened by increasing the strength of the strong solution and lessening the number of weak solutions.

In this practice one at the outset meets the fact that with increased strength of solutions there is an increased loss in cyanide. This may be shown by the following experiments, made upon the same ore and exposed to the solutions the same length of time, namely, fifteen hours:

	Experiment No. 1.	No. 2.	No. 3.
Per cent KCN solution before.....	1.0809	0.5404	0.1081
“ “ “ after.....	0.5145	0.0837	0.0042
Consumption KCN by difference.....	0.5664	0.4567	0.1009
Extraction of gold, milligrams.....	0.5	2.3	2.2
“ “ silver, milligrams.....	72.45	138.4	103.3
Percentage of extraction of total gold and silver.....	73.0	86.7	79.0

It is evident that the proper strength of the solution for this particular ore would be between that of experiment No. 2 and that of No. 3, since in the latter case nearly all the cyanide was consumed and the amount was shown to be too small for a maximum extraction.

It will be noticed that the consumption of cyanide by cyanicides did not influence the extraction in this case, where in No. 1 experiment it did.

The rate of percolation with weak solutions is not of so vital importance as it is sometimes made to appear, for it is essential that the solution should remain in contact with the ore until it has dissolved the gold. This of course applies only to fine gold, as with coarse gold unlimited time would be required, for which reason in some instances the tailings are washed slowly from the tanks over amalgamated-copper plates; in another instance cyanide was fed to the stamp-battery in order to commence early on the dissolution of coarse gold.

**Roasting Ores to Assist Leaching.**—In case the ore is to be dry-crushed a dehydrating roast should be given it, but not an oxidating roast, for that would produce sulphates with all their attendant evils. A dehydrating roast leaves ores in a porous condition and greatly aids cyaniding.

Such calcining must not exceed 300° F. in temperature; otherwise lime-magnesia ores will produce hydraulic cement and prevent percolation.

The theory of the dehydrating roast is that, the water of crystallization being driven off, the subcapillary pores in the mineral particles are in a condition to absorb the solutions, in fact are opened and do not close.

In case an oxidizing roast is given the ore, it must be thorough, otherwise the oxides will have more or less effect upon the solution. Mactear states "that the action of KCN on freshly precipitated oxides of iron, zinc, copper, and lead is greater than on gold, and that carbonates of the above metals are more readily soluble than gold."

With a partial oxidation the sulphates formed complicate the process, consequently the roast must be thorough or, as it is termed, "dead," thereby leaving no oxides or sulphates in the ore.

The action of alkali solutions upon oxidized ores produces hydrated oxides or carbonates which decompose KCN.

There is no doubt but that many ores will be benefited by a dehydrating roast, and still others by a dead roast, but this is a matter which can only be determined by actual experiment. It is well known that the character of an ore changes with depth, and that this change may be sufficient to warrant roasting before cyaniding.

**Silver Extraction—Roasting.**—It is claimed by some that roasting hinders the extraction of silver; upon what ground this statement is made, and it has reference to a dehydrating roast, is not recorded, but it would appear feasible in case of an oxidizing roast or

a chloridizing roast, otherwise the statement needs more explanation.

The treatment of silver by cyaniding does not differ much from that of gold; in fact they may be both leached with the same solution and at the same time. Chloride of silver is much more soluble in KCN solutions than gold, and this fact has led to a patent in which it is proposed to chloridize silver ores previous to cyaniding.

Silver seems to be more susceptible to the electrical than to the straight cyaniding treatment, and agitation also seems to increase its solubility.

As a rule very rich silver ores are not treated by cyaniding, and such silver as is met with in ores is mostly sulphide which is difficultly soluble in KCN solutions, with the exception of the subsulphide. With strong solutions silver is recovered in somewhat greater proportions than with weak solutions, yet the increased cost of the chemicals will, except in extraordinary cases, prohibit this practice.



## CHAPTER VII.

### PRECIPITATION OF GOLD FROM CYANIDE SOLUTIONS.

**Historical.**—Having obtained the gold in solution, the next step is its recovery in metallic form. MacArthur's first patent suggests the evaporation of the solution to dryness, and fusing the resulting saline residue. Any one acquainted with evaporation on a small plan knows how tedious such methods are; but when the danger from the poisonous fumes are also taken into account, it appears at once that this method is impracticable.

MacArthur next considered the feasibility of precipitating the gold with sodium amalgam, but this also proved unsatisfactory, as the mercury would oxidize quickly and refuse to unite with the gold.

The crudeness of these methods led to careful experiments, which finally settled upon fine filiform threads of zinc as the precipitant. This we believe is the only patent the MacArthur-Forrest people possess

which is valid, although much is said of the MacArthur-Forrest patents.

There have been numerous patents to replace zinc precipitation, which undoubtedly has faults, but none have been universally adopted.

Mr. Malloy suggested sodium or potassium amalgam, formed electrolytically from a solution of carbonate in contact with a bath of mercury. The alkali metal was to combine with the cyanogen of the gold, forming an alkali salt of cyanogen, while the gold was to be instantly amalgamated. The potassium cyanide was to be regenerated, but for some reason the patent has never been adopted.

Dr. Johnson used charcoal as a precipitant and obtained a patent for the process. The solution was run in through a central tube and then came up through a filter-bed of charcoal. The gold being precipitated by the charcoal, the solution flowed away clear. By one filter he recovered 25 per cent of gold, and by a series of filters 95 per cent of the gold. Prof. Christy made some elaborate experiments with this process under more favorable conditions than would occur in actual practice, and his deductions were that Dr. Johnson's claims could not be verified. He says: "It would seem that a given amount of a certain charcoal has a definite capacity of precipitation; that within this limit it acts completely and promptly;

beyond this limit it acts less completely and quickly; and that finally it ceases to act at all." "The presence of free KCN seems to lower its capacity, and perhaps at a certain point stops it altogether; acidification seems to increase its capacity." It was well known that charcoal would precipitate gold from solutions, as it had long before been used for precipitating gold from chlorine solutions, and the great difficulty in the way of its general adoption came from trouble experienced in recovering the gold from the charcoal. It is not at all probable that this method of precipitation as it now stands will come into general use, because of the large quantity of charcoal it requires and the difficulty of recovering the gold from the charcoal ashes.

Fremy states "that aurocyanide is precipitated by mercuric chloride according to the reaction

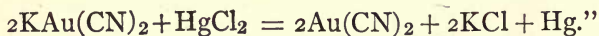

Prof. Christy tried this reaction, and found that heating the solution greatly assisted the precipitation. "This method adds so many complications and so much expense to the leaching process that it is robbed of whatever advantages it may possess; besides in the presence of free potassium cyanide precipitation does not take place."

**Precipitation of Gold by Cuprous Salts.** (Christy.)—

“It must be evident to those who have followed the progressive development of the cyanide process that, as the method is better understood, the constant tendency is towards the use of more and more dilute cyanide solutions. While in the beginning a solution of 1 per cent was used, this was first reduced to one half, then to one quarter, and finally to one tenth and even one twentieth of 1 per cent. As the action of the so-called ‘cyanicides’ contained in the ore is better understood and prevented, it seems not unlikely that the strength of the solution in potassium cyanide may be reduced to one one-hundredth of 1 per cent or even lower. It should be remembered that much of the material treated by this process does not assay over \$3 per ton, or only half of one one-thousandth of 1 per cent gold. So that a ton of solution of 0.01 per cent potassium cyanide solution contains thirty times as much cyanide as is needed to dissolve \$3 worth of gold in a ton of ore.

“The present methods of precipitation, the electrical and the zinc-shavings method, both find in these dilute solutions their great difficulty. In the electrical process the resistance of such solutions is something enormous.\* In the case of the zinc shavings it is practically impossible to precipitate the gold from such a solution unless it contains one or two tenths per cent

---

\* See Electrical Precipitation.



free cyanide of potassium. This fact alone prevents the cyanide from being utilized to the best advantage.

“In order that the cyanide should be utilized to the full, we should form the maximum of  $\text{KAu}(\text{CN})_2$  and leave a minimum of free  $\text{KCN}$  in the solution. This, as has been pointed out, is fatal to the precipitation by zinc shavings. But it is just here that the cuprous method of precipitation comes into play most efficiently.

“In the treatment of such solutions with a bare excess of potassium cyanide there is no method of precipitation yet invented that can compete with it. In such a case there is not enough cyanide of potassium in the solution to bother about saving it.

“The method of procedure would then be as follows: The solution would be made slightly acid by sulphuric or sulphurous acid, as might be most convenient. Then there would be added a copper sulphate solution with common salt, which had been saturated with sulphurous acid. This solution should be added until the filtered solution gives a red precipitate with potassium ferrocyanide. The whole solution should be thoroughly stirred before this end point is determined. A neat way to determine the end point is to place a few drops of the stirred mixture on a double layer of fine filter-paper. On removing the upper layer, a drop of ferrocyanide of potassium will give a red precipitate of cuprous ferrocyanide on the

wetted spot of the lower layer when the end point is reached. This method avoids the delay of filtering the solution in the ordinary way. It would, of course, be best to determine the end point beforehand with a liter of solution, and then add the copper salt to the mass of solution, after a preliminary calculation as to how much is required.

“The solution should be allowed to stand for at least twelve hours, when it should be filtered. The filtrate should stand another twelve hours to see if any further precipitate forms; or it may be filtered first through  $\text{CuS}$ , to remove any suspended or dissolved gold, and then through old scrap-iron to throw down any copper contents.

“For the recovery of the gold from the cuprous aurocyanide, Prof. de Wilde suggests three methods as follows:

“First method: Roasting in a reverberatory furnace. One obtains thus a residue of gold and of oxide of copper ( $\text{CuO}$ ). This latter is then dissolved in sulphuric acid diluted to  $20^\circ$  Baumé (or in dilute nitric or hydrochloric acid), and the gold remains in the residue as pure gold.

“At the same time the sulphate of copper is regenerated, which will serve to precipitate the gold in subsequent operations,\* and the same quantity of

---

\* “The sulphate of copper thus regenerated should be crystallized

copper may continue to serve. Owing to the sharpness of the reactions, the loss of copper will be insignificant.

“ ‘Second method: Solution of the cuprous cyanide in dilute chlorhydric or nitric acid; there remains a residue of aurous cyanide which, after washing and drying, is decomposed by heat, and pure gold is left behind.

“ ‘Third method: The precipitate is heated with 60° Baumé sulphuric acid in a porcelain or iron pot; it is entirely decomposed, leaving a residue of pure spongy gold. After cooling water is added, the precious metal is washed by decantation, dried, and melted. The copper has been transformed into sulphate.

“ ‘The first method appears to me the most rational, the roasting being attempted once or twice a month only. It is an inexpensive operation, and the sulphate of copper is thus regenerated.’

“ ‘In this matter I agree with Prof. de Wilde. After being carefully dried the conversion of the cyanide takes place very quietly at a low red heat, and the

---

by cooling the solution, and the crystals drained from the adherent acid mother-liquor. A solution of sulphate of copper containing a notable quantity of sulphuric acid is not adapted to the precipitation of gold. The mother-liquors, after being strengthened by the addition of sulphuric acid, serve very well for the attack of the mixture of oxide of copper and gold.’

spongy, porous, black residue readily dissolves in the sulphuric acid, leaving the gold very clean. Care should be taken not to alloy the gold and copper by a reducing atmosphere and too much heat.

✓ “A fourth method would be to dissolve both gold and copper cyanide in a strong KCN solution, and precipitate pure gold by the dynamo. With less than 2.5 volts and a strong solution of KCN this is possible, the copper remaining in solution. This I have verified. All the objections to electrolysis apply, except that the bulk of the solution would be small and it would be concentrated.

“In many cases it would probably prove more advantageous for the reduction-works to ship this precipitate without attempting to reduce it, as the technical skill to do this occasional work is hard to get in mining camps.

“The methods here outlined will certainly fail in the hands of those without chemical knowledge and engineering skill, and many unforeseen difficulties will probably have to be overcome before they can be utilized in practice. Nevertheless I feel very confident that in some of the methods here outlined for the precipitation of gold by means of cuprous salts will be found the missing link in the chain of operations necessary to utilize the extremely dilute solutions of cyanide of potassium, which have been found effective



in extracting gold from low-grade ores. If this should prove to be the case, and the usefulness of the method should be extended, particularly in California, my native State, I shall feel amply repaid for this long labor."

**Zinc Precipitation.**—Gold may be precipitated by zinc in three ways: first by the use of zinc shavings; second by zinc fume, known as blue powder; third by zinc amalgam. The action in each case seems to be electrolytic, as very small interchange of metals occurs; this statement is further substantiated because of the hydrogen formed in the precipitation-boxes at the cathode of zinc shavings. There is an exchange of metals in the electrolyte according to the equation

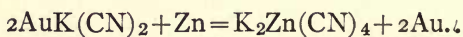

According to the substitution reaction 1 ounce of zinc should precipitate 6.2 ounces of gold, but as a practical matter it requires about 12 ounces of zinc to precipitate 1 ounce of gold. This has induced chemists to look for the discrepancy between theory and practice.

According to the above equation auro-potassic cyanide splits up into KCN, Au, and CN, but there is also a tendency to split up into K and AuCN<sub>2</sub>, the latter acting as an acid radical. If this takes place in the presence of zinc and water, the water will be

attacked by the potassium, forming caustic potash (KOH) and hydrogen, and the  $\text{Au}(\text{CN})_2$  will be attacked by the zinc, forming cyanide of zinc and liberating metallic gold. This reaction may occur according to the following equation:

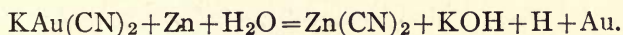

If this reaction occurs, it accounts for the hydrogen, and for the fact that zinc shavings with rough edges will precipitate gold, while smooth zinc or thicker zinc will not. When the reaction sets in above there is a further reaction between the caustic potash and zinc cyanide, and potassium zincate is formed. Some chemists have stated that at this point a loss occurs according to the equation

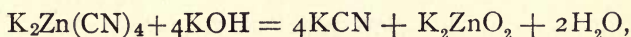

but it can be demonstrated by experiment that any oxide of zinc and potassium combines with KCN to form potassic-zinc-cyanide and caustic potash; for example,

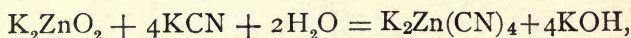

which indicates that zinc oxide takes up the cyanide although the silver nitrate test would not show it. Alfred James considers this a drawback to zinc precipitation, but sulphides in the ore and in the solu-

tions will moderate the accumulation of zinc, and if it does not, treatment with sodium sulphate and lead salt will act as a remedy.

The above deductions are made upon the grounds that free potassium cyanide is in the solution, and this is not to be doubted, hence the equation advanced by some noted chemists is not possible, viz.,

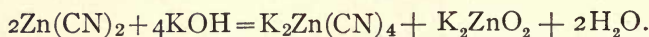

Prof. Christy advances the reaction which takes place to be something like this:

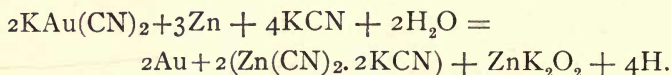

However, he does not consider his probable reaction demonstrated, and merely advances it to account for the extraordinary loss of zinc. There is no absence of free potassium cyanide in the zinc-box and hence the reaction is void; but if there were no free potassium cyanide and caustic potash, 1 ounce of zinc would theoretically precipitate 3.1 ounces of gold.

**Influences Governing Zinc Precipitation.**—*Zinc shavings* must be made very thin, in fact they are made  $\frac{1}{1260}$  inch thick by  $\frac{1}{32}$  inch wide in some cases, and when of this description 1 pound of zinc will furnish 1630 square feet of surface, and the consumption will be about 5 ounces per ounce of gold. In Fig. 10 is

shown a lathe for turning the zinc shavings. In the illustration *a* is a mandril between the sides of which thin discs of as pure zinc as it is possible to obtain are placed and clamped tight by the nut *b*. The lathe has three speeds, as shown by the pulley-wheels *e*. The

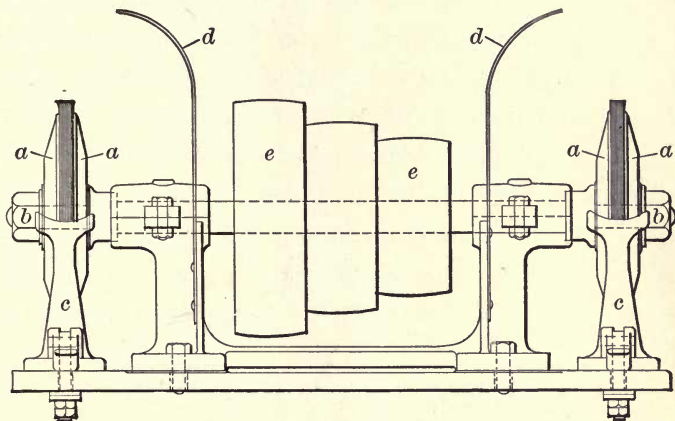

Fig. 10

tool-rest is shown at *c*, and the guards to prevent the shavings flying over the belts at *d*. Zinc discs can be bought ready for turning, at mill-supply depots.

The solution passing into the zinc-boxes which are newly filled has very little effect upon the zinc, but when once the action is started it is quite rapid.

The author has had numerous letters of inquiry from students and others stating that they could not precipitate their gold with zinc. His answer was invariably that either the zinc was too thick or the solution too



weak, and advised that the solution be allowed to stand in contact with the zinc some time and then strengthened by the addition of potassium cyanide. This has always proved efficacious except where the zinc has been too thick, precipitation commencing almost immediately after the KCN was added.

The physical condition of zinc has much to do with precipitation, for which reason old zinc is better than new. The usual practice is to add fresh zinc to the last box of the series, and as the zinc in the first box is dissolved, move that from the second to the first, and from the third to the second, and so on. By this means old zinc in an active state meets the solution coming from the gold-solution tanks and precipitates it quickly.

Complete precipitation of the gold by zinc has not been attained as yet, but as high as 96 per cent is obtained. The gold, however, is not lost, and is useful in the next solution, for after cyanide solutions have taken up a certain amount of gold they seem to be quickened and in a condition to dissolve the gold in the leaching-yats more rapidly. A. K. Huntington seems to think that this shows there is real utility in using solutions over and over again without extracting all the gold from them.

**Different Strengths of Solutions.**—Strong solutions act more quickly on zinc than weak, and consequently

there is more cyanide lost, as well as zinc. There can be little economy in this practice from the fact that a loss of cyanide occurs all along the line from the leaching- to the solution-tanks. Leaching should be done with the weakest solutions possible, with a high extraction, and precipitation should be of secondary consideration. In case the solutions are so weak that the gold cannot be precipitated (and they must be very weak indeed, as .007 per cent. solutions have gold precipitated from them), free potassium cyanide can be added to the solution as it enters the zinc-box and so bring up its strength to the precipitation point.

**Impurities in the Gold Solution.**—The solution as it comes to the zinc-boxes contains, besides chemical impurities, sediment which is deposited sometimes on the zinc and again falls to the bottom of the boxes as slime, mixing with the gold and zinc which also fall there. It is impossible to remove this sediment entirely, even when slimes are washed from the ore, but other than in a mechanical way it does not influence the precipitation or the power of the solution for dissolving when strengthened for the next leaching. By using the solutions over and over again they become very foul and have to be abandoned or settled.

**Rate of Flow.**—As noted when the construction of zinc-boxes was discussed, the flow into and out of them is made continuous. The solution should travel at

such a speed that about all the gold will be precipitated, and not faster or slower. There is not much danger of the gold being precipitated outside the box unless it should occur in the next leaching, which, while possible, is not probable.

**Chemical Effects.**—In some cases aluminous substances are thrown down both in the gold-tanks and in the precipitation-boxes, and these seem to hinder precipitation. Caustic alkalies will in a measure hinder precipitation, particularly soda, for which reason, if it cannot be thoroughly washed from the ore in preliminary treatment, quicklime is preferable as a neutralizer.

Acidity of the solution has little effect upon precipitation, in fact should prevent the precipitation of some base-metal salts if they are present. The presence of calcium carbonate and zinc oxide in appreciable quantities would hinder precipitation by coating the zinc, and preventing the solution acting properly. Zinc for precipitation must not contain arsenic, antimony, or much lead, although a small percentage of the latter is not injurious. In some cases zinc is placed in a solution of acetate of lead of, say, 10 per cent strength in order to cover it with a porous coating of lead. This is termed "pickling the zinc" and is practised to precipitate the gold from weak solutions especially in the presence of copper, which sometimes prevents gold from precipitating. According to Mr. T. L. Carter, after cutting

the zinc in the lathe it is taken to a trough which contains a 10 per cent solution of acetate of lead, where it is submerged and stirred until it becomes of a dark hue.

Dissolved copper deposits more rapidly from weak cyanide solutions than strong ones, and soon covers the zinc with a bright metallic coating, beginning at the lower boxes and gradually working up towards the upper ones.

When the zinc becomes coated with copper the precipitation is very slow. The remedy in such cases is to strengthen the solution by the addition of cyanide, but here an excessive use of cyanide occurs, and the copper goes into the stock and sump solutions, eventually rendering them worthless.

Lead-coated zinc will effect the perfect precipitation of gold and leave the copper even in the weakest solutions, but the resulting bullion becomes impure from the lead.

**Objections to the Use of Zinc.**—The objections to the use of zinc as a precipitant are such as to create considerable comment. It is considered too expensive by some, because of the loss of cyanide in the zinc-precipitating boxes and because it requires so much zinc. Others consider it from a different standpoint, namely, that the recovery of bullion from its use is too coarse, and the recovery by refining too complicated, together



with a certain loss of gold and silver due to refining those metals with zinc. The numerous methods suggested do not seem, however, to have driven the zinc-precipitating process to the wall, although it may in time.

“Examination of precipitants from a cyanide mill, consisting of gold, silver, copper, calcium carbonate, and fine shreds of zinc, showed that copper was not in a metallic state, because it dissolved with effervescence in dilute HCl.” Mr. Eichbaum observed that zinc does not precipitate copper from a solution made with potassium cyanide of 98 per cent purity; but on adding iron a brisk evolution of gas took place, but no copper was precipitated. If an impure cyanide solution is used, copper is soon deposited upon the zinc, which is no doubt due to caustic or carbonate in the solution.

The solution, after gold has been deposited, contains zinc, yet the solution, after being used for months, does not cause inconvenience. By the addition of water the zinc could not saturate the solution, and the same is true of alkali carbonate, which, in the absence of lime, is continually forming. The white precipitant is the result of alkali on zinc, and of the zinc potassic oxide on the double cyanide of zinc and potassium, as shown by the formula, and which is insoluble. This double cyanide of zinc and potassium, being used over

again in the percolating-vats, forms, with the iron salts in the ore, ferrocyanide of zinc.

Buckland considers this the reason for constant removal of zinc from the solution with the residues.

This double cyanide of zinc and potassium formed during precipitation of gold is not available for dissolving gold in new operations, but it does not appear to be detrimental to the process when new cyanide solution is added to it. It does not precipitate gold dissolved by a new solution of cyanide.

Auro-potassic cyanide seems to be a very stable compound, and not readily decomposed, as is evident since, when once deposited on zinc, the gold does not become redissolved so long as zinc is present.

Francis L. Bosqui, in the Transactions of the American Institute of Mining Engineers, champions the use of zinc as follows:

“ 1. *The great consumption of zinc compared with the amount of gold precipitated.*

“ The record of zinc used at Bodie in the treatment of 52,665 tons of tailings indicates a consumption of 0.22 pound per ton, at a cost of about 3 cents per ton; assuming the price of sheet zinc laid down in Bodie to be 9.3 cents per pound, and the cost of cutting it about 4 cents per pound. To be more pertinent, there is a consumption of 1.39 pounds of zinc, at a cost of 18.4 cents, per ounce of gold recovered. Theoretically

this consumption is enormous, for it should require only about 1 pound of zinc to precipitate 6 pounds of gold; but economically it is very small, since it means a cost of only 3 cents to the ton of tailings.

“2. *The great destruction of potassium cyanide to no useful purpose.*

“It has been often contended that zinc-precipitation calls for the use of stronger solutions than might otherwise be resorted to. Prof. Christy stoutly claims for his and for the electrolytic method the one paramount advantage that they admit of the use of very dilute solutions of potassium cyanide. At Bodie exhaustive experimental tests were made by Mr. C. W. Merrill to determine the proper strength for a cyanide solution, i.e., with respect to its extracting power on Bodie tailings; and the conclusion was reached that a solution containing less than 0.1 per cent cyanide was not so available as a stronger one. The fact, then, that solutions containing less than 0.2 per cent cyanide were found unavailable for the best extraction in Bodie would nullify the chief advantage claimed for both the newer methods of precipitation, at least so far as this particular camp is concerned.

“We know that, theoretically, there is a consumption of cyanide during precipitation, that is, during the flow of solution through the zinc-boxes. Some writers have laid particular stress upon this, as being one great

source of cyanide consumption. I have often tried to determine just what this consumption is, by making comparative titration tests on a solution flowing into, and a solution flowing from, the same zinc-box. I have made these tests very frequently and carefully, but have never found the slightest difference in quantity between the cyanide present in an ingoing solution and that present in an outgoing solution, from the same zinc-box; the two samples being taken at the proper interval of time. I am aware that the reliability of the silver-nitrate test, as a delicate method of determining the amount of cyanide present in a given solution, has been called into question. But even assuming that the presence of zinc in the solution does vitiate the test to a certain extent, it is hardly probable that the amount of zinc accumulated during a single flow through a zinc-box would be sufficient to destroy the validity of a comparative test. In fact the quantity of zinc present in 80 tons of strong solution, determined quantitatively at the end of one of our first season's runs, was so infinitesimal as to preclude any such conclusion.

“ There is still another reason for supposing a comparative silver-nitrate test on ingoing and outgoing solutions to be reliable, namely, the remarkable coincidence that in each case the well-known precipitate came down at precisely the same point in the two test-



tubes. In other words, the density of the precipitate was exactly the same in the two tubes, when a common point was reached on the burette. This would hardly occur with such invariable precision if the test on outgoing solution were really vitiated by the presence of zinc accumulated during a single flow through a box.

“ The silver-nitrate test is a very simple and serviceable one, and, so far as I know, has been generally retained in practice. Even if it be, in the long run, somewhat vitiated by the presence of zinc in the solutions, it still indicates what might be called a ‘dissolving strength,’ and is, therefore, for all practical purposes, efficient.

“ The amount of cyanide present in our strong-solution sumps averages from 0.14 to 0.16 per cent. As there is no perceptible consumption of cyanide in the zinc-boxes, it is safe to assume that this deterioration of strong solution is due to the action of ‘cyanicides’ during leaching, and to its dilution by the original moisture in the tailings and by the final wash-water.

“ All solutions containing more than 0.1 per cent of KCN are run directly into a ‘strong-gold solution-tank’; those containing less, into a ‘weak-gold solution-tank.’ The excess of this weaker solution over and above what is used in the preliminary leaching is run through a series of ‘waste zinc-boxes’ and then to waste. This waste

solution averages in strength about 0.05 per cent KCN. There are approximately 14 tons of it run to waste in twenty-four hours. This may look like an enormous consumption of cyanide, but the system, on close examination, will be seen to have one great advantage. It prevents an excessive and unwieldy accumulation of strong solution, while the amount of cyanide in the waste is really small, in comparison with what would be required to raise it all to standard strength. This accumulation of weak solution is unavoidable where there is an abundance of water available for wash-water, and where practically all the cyanide solution in a vat of tailings is displaced before sluicing.

“ The consumption of cyanide at Bodie on a total run of 52,665 tons of tailings was 0.41 pound per ton; on the first 41,730 tons it was 0.38 pound per ton. The latter figures represent a treatment of 78 tons per day for 535 days. From these data we might indicate approximately just what the consumption of cyanide is in each stage of the process. On a daily treatment of 78 tons the consumption was 30 pounds. The loss of cyanide in spent solution (assuming that 14 tons per day go to waste, containing 0.05 per cent of KCN) is about 14 pounds. This leaves 16 pounds per day still to be accounted for. It was ascertained by tests made in percolators on average samples of tailings treated that the loss of cyanide in actual leaching is about 0.2

pound per ton, or 15.6 pounds per day. This leaves a balance of 0.4 pound per day or 0.005 pound per ton, which we may assume as the loss of cyanide during precipitation, a very insignificant amount.

“ These results are summarized as follows:

	Per day, lbs.	Per ton, lbs.
Consumption of KCN in spent solution	14.0	0.179
Consumption during actual leaching. .	15.6	0.2
Probable consumption in zinc-boxes. .	0.4	0.005
Total consumption of KCN. . . . .	30.0	0.384

“ Of our success in precipitating gold from weak solutions I shall speak in its proper place.

“ 3. *The great difficulty of removing zinc and cyanogen residues from the gold, thus causing loss in melting, and the production of an unclean bullion.*

“ I will admit that this was a great difficulty with us at first, and one which, for a time, seemed insurmountable. It was necessary to devise some means of separating the zinc-sulphate residues from the gold-slimes, after the regular treatment with sulphuric acid. Various forms of filter were tried. A perforated false bottom of wood, packed with sand, was discarded after several trials, on account of the impermeability of the layer of slimes which formed on top of the sand. A filter of asbestos cloth was resorted to, but was likewise

discarded. It not only proved to be an imperfect filter, but was found completely disintegrated after the subsidence of the action of the acid, a result probably due to the mechanical untwisting of its fibers during the reduction of the zinc. We were obliged at this time to use a succession of washes, in order to dilute and gradually eliminate the zinc sulphate—allowing the slimes to settle completely each time. This method, however, was slow and laborious. A Johnson filter-press was next introduced. It seemed to act fairly well on the slimes before acid treatment, but after the destruction of the zinc the gold precipitate apparently became too finely divided to admit of filtration. A film of not more than  $\frac{1}{8}$  inch in thickness on the canvas discs of the press seemed to offer a very complete obstacle to the passage of the clear liquid. The pressure against the discs would run up to over 100 pounds; the press would then have to be opened and the discs scraped. This method was found too tedious, and was finally abandoned.

“After many discouraging failures, the following *modus operandi* was adopted, and has since been followed with perfect success:

“The slimes and fine zinc are discharged directly from the zinc-boxes into a redwood vat, 6 feet in diameter and 2 feet deep. This vat is protected on the inside by several coats of paraffine paint, has a



slight bottom incline for drainage, and is provided with a 2-inch discharge-valve. Here the slimes are treated with sulphuric acid. After the destruction of the zinc, the zinc sulphate and the slight excess of acid present are diluted by filling the vat with warm water. Within an hour the bulk of the precipitate will have settled to the bottom. The supernatant liquor, to the amount of about 400 gallons, which still contains a small amount of gold-slimes in suspension, is then siphoned off into a 10-ton settling-vat.

“The gold-slimes are treated with a succession of these washes, the supernatant liquor being each time drawn off into the settling-vat until the amount of zinc sulphate remaining in the slimes is insignificant. The liquor siphoned off into the settling-vat, which contains only a very small quantity of slimes in proportion to the total quantity obtained, is left to settle between clean-ups. The clear liquor is drawn off just before a succeeding clean-up, and at long intervals the precipitate is gathered from the bottom and melted.

“The bulk of the slimes is finally discharged from the acid-vat into a filter-box. This box is provided, about a foot from the top, with a perforated partition, which is closely covered with two thicknesses of ordinary mill-blanketing. From the compartment beneath this filter the air is withdrawn by means of a steam-ejector, and the water is thus removed from the

slimes by suction. At the bottom of the box is a 1-inch discharge-valve for drawing off the accumulated clear liquid. By occasionally scraping the filter-blankets the passage of water through them is greatly facilitated. These blankets are removed and washed after each clean-up, and clean ones are substituted. The partially dried slimes from the blankets are then completely dried over a furnace and melted in crucibles. The zinc residues being thus pretty thoroughly removed from the slimes, the difficulties in melting are reduced to a minimum.

“ Prof. Christy lays some stress upon the losses in melting. There is sure to be some loss from ‘dusting,’ especially where there is a high draft in the furnace-flues, and where the pots are carelessly charged with the dried slimes.

“ For some time a considerable value went into the slag, which had to be shipped to the smelting-works; but after a good deal of experimentation a very suitable flux has been found, which reduces the slag value to almost nothing. A dust-chamber has been constructed in connection with the melting-furnace, and an effective damper introduced in the course of the flue. The latter is closed at each charging of the crucible, and ‘dusting’ is thus almost entirely avoided.

“ Our loss in melting has never been more than barely appreciable; and now, since the introduction of

a dust-chamber and damper, is wholly insignificant. The wonderfully close correspondence between our actual bullion-yield and the extraction indicated by careful assays of charged and discharged tailings would in itself weaken the supposition of any considerable loss in melting. To be sure, our bullion is low-grade, but we suffer no inconvenience from this except the small increase in cost of transportation and refining in proportion to the value of the bars.

“4. *The failure, in certain cases, to precipitate the gold.*”

“Prof. Christy probably alludes here, more particularly, to the difficulty in precipitating gold from a weak cyanide solution. He says that ‘in the case of zinc shavings it is practically impossible to precipitate the gold from such a solution unless it contains one or two tenths per cent free cyanide of potassium.’”

“In Bodie practice it has been found perfectly practicable to precipitate gold completely from solutions containing as little as 0.05 per cent of cyanide. Our weak solutions are run through a series of zinc-boxes, of ten compartments each, before going to waste. Each compartments has a capacity of about 8 pounds of zinc shavings. The solution, after passing through about 160 pounds of zinc shavings, is found to be practically free from gold; repeated assays indicating merely a trace.

“ At the Victor plant, of 50 tons per day capacity, considerable difficulty was experienced in precipitating gold from weak solutions; but by the addition of a third box, making an aggregate of thirty compartments, the trouble was corrected and most satisfactory precipitation was obtained.

“ The following table of assays made at random on solution samples from various zinc-boxes at different intervals in the season’s run indicates a high percentage of precipitation in both strong- and weak-solution boxes. These results were obtained by evaporating 250 c.c. (about 8 assay tons) of the solution in each case, and assaying the residues.

	Strong or Weak.	Value of the Ingoing Solution per Ton.			Value of the Outgoing Solution per Ton.		
		Au.	Ag.	Total	Au.	Ag.	Total
1	Strong (0.14 to 0.16 per cent.)	\$4.24	\$.45	\$4.69	\$.05	\$.02	\$.07
2	“ “ “ “	4.39	.43	4.82	.10	.03	.13
3	“ “ “ “	4.03	.44	4.47	Trace	.....	.....
4	“ “ “ “	4.13	.46	4.59	Trace	.....	.....
5	“ “ “ “	3.32	.38	3.70	.10	.06	.16
6	“ “ “ “	3.05	.39	3.44	.26	.07	.33
7	Weak (0.04 to 0.07 per cent.)	1.24	.14	1.38	Trace	.....	.....
8	“ “ “ “	2.90	.45	3.35	.07	.07	.14
*9	“ “ “ “	3.82	.57	4.39	.25	.07	.32
*10	“ “ “ “	4.13	.64	4.77	.21	.08	.29
*11	“ “ “ “	1.14	.16	1.30	Trace	.....	.....
*12	“ “ “ “	.52	.15	.67	Trace	.....	.....

\* We have occasionally been puzzled by the appearance in our zinc-boxes of a yellow, aluminous (?) precipitate, which seems to be thrown down in the gold-tanks as soon as the solution leaves the vats. Whenever this accumulates to any extent it interferes somewhat with precipitation. Assays Nos. 9 and 10 were made on solutions taken from a box containing a considerable amount of this aluminous slime. The slightly lower percentage of precipitation is apparent. The two following assays (Nos. 11 and 12) were made on a low-grade solution flowing through the same box, after a complete elimination of the aluminous material, and indicate a normal precipitation.



**Precipitation with Zinc Fume.**—This process is adopted at Delamar, Idaho, and Mercur, Utah. The action of zinc fume is almost instantaneous, but when used for precipitating, the cyanide solution is agitated by compressed air, for the purpose of stirring up any residues remaining in the bottom of the precipitation-tank from former operations. The zinc fume, which is the volatile zinc from smelting operations that has been condensed and caught in the flues, contains about 90 per cent zinc. For the purpose of gold precipitation it is sifted into the tanks at intervals during agitation. Five pounds of zinc fume, or blue powder as it is called, will precipitate the gold from 30 tons of cyanide solution at Mercur; the quantity of gold in the solution, however, is not stated. From other sources it is claimed that from 6 to 19 ounces of zinc fume will precipitate 1 ounce of gold.

A case of considerable interest regarding the use of zinc dust or fume as a precipitant of gold and silver from cyanide solutions was recently decided by the United States District Court for Idaho. The court decided against the plaintiff and held that the patent was anticipated by prior publications and patents. Those wishing to use the process may be interested to know what are the claims of the patent in question, as well as something of what was known regarding this use of zinc dust prior to the application for the patent.

UNITED STATES PATENT NO. 607,719 FILED  
MARCH 9, 1896.

“Claim 1. The process of extracting precious metals from cyanide solutions, which consists in treating said solutions with zinc dust, to wit, the herein-described material composed of zinc and zinc oxide, in a state of agitation, substantially as described.

“Claim 2. In the process of extracting precious metals from cyanide solutions the use as a precipitating reagent of a definite quantity of zinc dust in a state of agitation, the quantity of said zinc dust being supplied in only a sufficient quantity to thoroughly precipitate the contained metals, substantially as described.

“Claim 3. The process of extracting and recovering precious metals from their ores and which consists essentially of the following steps: First, subjecting the ore in a powdered state to the action of an aqueous solution of a cyanide; second, supplying to the solution charged with the precious metals that quantity of zinc dust determined to be exactly sufficient to precipitate said metals; third, agitating said solution and said zinc dust until said metals are precipitated and said zinc dust is absorbed; fourth, recovering the precious metals from the valuable precipitate of the preceding steps by filtration or other process, substantially as described.”

In a paper read by Mr. H. L. Sulman before the Institution of Mining and Metallurgy (London) on February 20, 1895, he says that all the conditions are fulfilled "by the product known as zinc fume. . . . It is a commercial by-product, . . . being condensed metallic zinc vapor in a state of extreme division." "It is an impalpable powder more or less coated with oxide, which somewhat retards the precipitating action unless treated with dilute ammonia or some similar solvent to clean the zinc." "A small portion of this preparation agitated with a very dilute solution of auro-potassic cyanide permeates the whole volume of liquor, rendering it slightly and uniformly cloudy . . . and almost immediately determines the precipitation of the gold." "I have treated gold solutions of varying strengths of cyanide and with an expenditure of zinc fume never exceeding 0.5 pound per ton of ore, and have obtained precipitates which seldom contained below 97 to 98 per cent of the gold originally present in the liquor." "When the solutions are rich in metal (or over 0.3 ounce per ton) the addition of zinc fume of from three to four times the weight of gold present has been sufficient to completely precipitate the latter. Very dilute solutions, strangely enough, require rather more than this."

It will be seen from the quotations given that every claim of the Waldstein patent is anticipated by Sul-

man. The only difference between the two is in Sulman's treatment of the zinc dust with an ammoniacal solution to remove the oxide. His United States Patent No. 576,173, filed February 25, 1895, also clearly shows that he did not consider it possible to patent the use of zinc dust alone as a precipitant, for all he attempts to cover in his patent is the process for removing the zinc oxide so as to make the zinc more active, and a special form of apparatus in which to make the precipitation. The price of zinc dust is from 6 to 7 cents per pound.



## CHAPTER VIII.

### TREATMENT OF BULLION.

**Melting Gold Precipitates.**—Having deposited the gold upon zinc, the next process is to recover it in the form of bullion. The gold is deposited as a black slimy mass, and the zinc with the gold adhering is shaken in water, when the gold and some of the zinc fall off. The water is next drained off through a filter, and the fibrous particles of zinc collected in a sieve and shaken again to remove gold. The last sifting removes the coarse zinc from the precipitates, which now contain gold, silver, and zinc, and, if the residues in the filter-boxes are added, other metals and impurities. This precipitate is thoroughly dried and roasted slowly, care being taken that the flame does not come in contact with the mass. After being thoroughly dried it may be refined by the “calcining and roasting process” or recovered by the “acid process.”

The roasting process is used where oxidation of base metals has not been complete. At Johannesburg, South Africa, the acid treatment is not employed, as it

involves washing and filtration of the slimes, with loss of gold by formation of regulus in melting, if sulphates remain in the slimes by fault of imperfect washing. The practice is to dry the slimes to dust nearly; then to thoroughly mix them with powdered niter, the amount varying from 3 to 33 per cent of their weight, and this mass is gently heated on a wrought-iron tray. The flames must not come in contact with the slimes, and the gases should be conducted up a flue away from the operator. By the use of niter everything connected with the precipitate is refined. After this oxidation the roasted mass is placed in plumbago crucibles with the proper fluxes.

When metallic oxides are present, the flux is composed of six parts roasted niter slimes, four parts borax, two parts soda, one part sand. When only a small amount of metallic oxide is present the charge may be three parts slimes, one part borax, two parts soda, one part sand. The function of the sand is to form a fusible slag with soda, and protect the pots from metallic oxides and potash formed by the reduction of the niter. The slag resulting from the melting of these slimes usually contains more or less gold; it is therefore crushed and sent to the smelters. At some mills these slags are crushed and panned for gold, and the tailings sent to the smelter. Fluxes which give clean fluid slag are preferable in this as in any other refining.



The crucible previously annealed is placed on a flat fire-clay tile resting on the bars of the refining-furnace. A charge of precipitates is then put in the crucible, and as they subside fresh precipitates are added. When the crucible is two thirds full, the slag is skimmed off and fresh portions of precipitates added until it is three fourths full of molten bullion.

The crucible is then removed from the furnace, and the contents poured into ingot-molds which have been previously heated and oiled. All excess of oil should be wiped out of the mold before pouring the metal. It is sometimes advisable to smelt the bullion a second time if much zinc is present with the gold, and as zinc and gold form a very poor alloy it should be carried on at a low heat.

**Sulphuric Acid Treatment.**—This method of treating gold precipitates is practiced chiefly in the United States, but is being adopted in South Africa and New Zealand. For the sulphuric acid treatment wooden tubs are sufficient; after the precipitates have been thoroughly washed with water they are run into the acid-tank shown in Fig. 7, *A*. The precipitate is very slimy, in fact the freer it is from zinc the more slimy it is. The quantity of dilute sulphuric acid used to dissolve the zinc will depend upon the quantity of zinc in the slimes. The acid should not be too strong; possibly one part acid and ten parts water will be

sufficient, as it has been found that this strength will create an action sufficient to produce heat enough to make the operation speedy and satisfactory without the aid of outside heat. After the zinc has dissolved no more hydrogen gas will be evolved, but before decanting the mixture should be stirred, to make sure that all zinc has been dissolved. The last traces of metal zinc having been removed, the solid precipitates are allowed to settle, the liquor then being decanted off, and the residues washed into the filter, where they are thoroughly rinsed. The bullion is then partially dried on the vacuum-filter.

Should any zinc remain, its presence in melting the bullion will cause a mechanical loss of gold, as the zinc will volatilize in the crucible-furnace.

For this reason some treat the slimes first with a weak acid solution and then with a stronger acid solution.

The mass, after partially drying in the filter, is dried at a low heat in a small muffle-furnace, and when the moisture is driven off the heat is increased to a dark red.

Oxidation of the base metals which have escaped removal by acid treatment should be complete after one hour's roasting, the mass presenting a gray brown appearance. The roasted bullion is transferred to a wrought-iron box to be cooled, after which it is



pulverized. Borax glass and soda are added to make a clear slag. The roasted precipitates are then charged into a plumbago crucible previously primed with borax. As the mixture sinks in the crucible more roasted precipitates are added from time to time. The melting usually takes place rapidly. The temperature is kept high for some time, to give the small bullion globules time to collect. The contents of the crucible are then poured into a heated mould and allowed to cool. It is claimed that this acid treatment has advantages over the calcining treatment, being simpler and allowing the plumbago crucibles to be repeatedly used; also the bullion is finer and by care recovered without chemical loss.

**Removing Zinc Sulphate.**—After the zinc in the gold-slimes has been converted into sulphate of zinc by the sulphuric acid treatment, the solution is allowed to stand a few hours, and is then diluted with hot water and stirred. The sulphate of zinc, which is soluble in hot water, is gotten in solution and is siphoned off into the settling-tank as soon as the undissolved precipitates have settled. The precipitates in the acid-tank are thoroughly washed several times to remove traces of zinc sulphate, after which they are drawn into the filter-tank, and washed and dried by suction. The precipitates from the settling-tank are also drawn into the filter-box and washed there with hot water.

In some works the solutions used are passed directly to filter-presses, and the slimes obtained at once.

**Filter-tank.**—Where large quantities of precipitates are to be dealt with, the slime settling and decanting are too slow, for which reason the vacuum-filter or the filter-press is adopted, and the separation of slimes from the acid and the wash-water hastened. A vacuum slime-filter is shown in Fig. 11. It consists of an iron tank divided into two compartments, *a* and *b*, by a filter bottom, *c*, of wood which rests upon a central

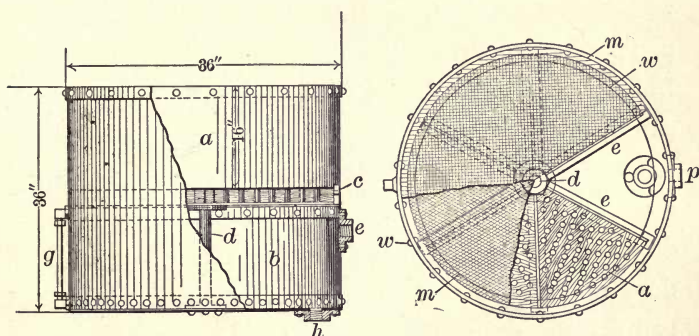

Fig. 11

post, *d*, and a ledge in the tank. Upon the wooden filter bottom heavy duck is placed, and upon it the slimes to be washed and treated.

As shown in Fig. 8, the filter is connected at *e* with an exhaust-pipe leading to the vacuum-pump, and is also provided with a discharge-pipe connection, *h*, and a water-gauge, *g*. The object of the gauge is to indi-

cate the height of the water in the lower chamber, *b*, as the water must be discharged before it reaches the height of the exhaust-pipe *e*.

**Bullion Produced.**—The bullion produced by the cyanide process must necessarily vary according to the grade of ore treated, and care taken for its recovery and refining. While one will recover bullion 950 fine, another can obtain only 750 fine or less. This case is important, since it may be more expensive in the end, as purchasers of bullion pay for its assay value, and refiners' charges are more for base bullion than fine; under such conditions it may be profitable to use care. Bullion precipitated by zinc has objections which can be overcome to some extent by close application to details, although at times they are in a measure unavoidable. The loss of bullion from smelting is one of the most objectionable features; the loss of zinc does not amount to much; the loss of cyanide is a bad feature, but unavoidable.

## CHAPTER IX.

### TREATMENT OF CONCENTRATES AND SLIMES.

**Auriferous Sulphurets.**—Under this heading are to be classed clean pyrites produced by concentration. When such pyrites are free from acid salts they can be treated satisfactorily in some cases, in others not, especially when copper is present. It is always advisable to keep concentrates of this description away from the air, for they will oxidize quickly, for which reason in South Africa they are kept under water. In the treatment of such ores it may be well to percolate with a weak solution first, and by this means obtain a larger extraction with less loss of cyanide from the strong solution following. The poor results sometimes obtained in the treatment of concentrates may be from not allowing sufficient time for the solutions to act upon them or not crushing fine enough.

In crushing sulphurets fine there is great danger of their sliming, they are much more brittle, and more easily pulverized than the remainder of the ore. When very fine they are also more difficult to size and concentrate.



It is possible to treat these concentrates by cyanide, but, being generally richer in metal, their treatment requires longer time for the best results. As their quantity is limited, the size of the plant need not be as extensive as where the whole mass of tailings is to be treated. Agitation will hasten the cyaniding of concentrates. Percolation with concentrates requires twenty days, because of the difficulty the solution encounters in passing through the coarse particles of ore. "Difficulty sometimes arises owing to the crystalline form of iron pyrites and galena. These minerals crystallize in cubes, and in fluids arrange themselves face to face, so that a section of such a mass deposited from fluid would resemble a brick wall in structure." Dr. A. Scheidel suggested mixing coarse sand with the cubes to overcome the difficulty.

The results of the experiments made upon tailings containing sulphurets by the California State Bureau of Mining are here given. A 1 per cent solution of potassium cyanide was used for the experiments.

The experiments illustrate the effect of time and strength of the solution, while they also illustrate that the solution is not impaired in its action when sulphides only are present, both of which are important items in considering the scope of the process.

Treatment lasting 2 hrs. :	tailings retained	35.29%	gold.
3 "	" "	31.37%	" "
4 "	" "	30.37%	" "
6 "	" "	25.49%	" "
8 "	" "	21.56%	" "

Another portion from the same lot of sulphurets ground and passed through a 100-mesh screen (the former having been passed through a 60-mesh screen) were then treated six hours. There was left in the tailings after this latter treatment 17.64 per cent of gold, showing that fineness of the ore in this case materially aided digestion.

To ascertain whether dilute cyanide would extract all the gold in these sulphurets the ore was ground in an agate mortar to impalpable powder, and digested for forty-eight hours with three different solutions of 1 per cent cyanide, after which treatment the tailings were found to contain 9.8 per cent of gold.

Another lot of sulphurets from which free gold had been removed with great care was subjected to a 1 per cent solution after passing a 120-mesh screen.

Treatment lasting 2 hrs. :	tailings retained	31.2%	gold.
3 "	" "	28.5%	" "
4 "	" "	15.6%	" "
5 "	" "	15.5%	" "
8 "	" "	10.4%	" "

The deductions to be made by comparison with the 60-mesh screen experiments are that double the fineness lessens the time by one half in the treatment of ore by cyanide solutions of the same strength.

**Treatment of Slimes.**—During the process of wet stamping a large portion of the ore is converted into impalpable powder, which is difficult to settle and difficult to treat with the sands. In one instance when stamping to a 30-mesh screen 74.28 per cent of the total was so fine that it passed through an 80-mesh screen or 6400 holes to the square inch, and carrying with it about 75 per cent of the gold.

In another case when crushing dry with rolls from  $\frac{1}{2}$  to  $\frac{1}{4}$  inch, 47.8 per cent went through a 20-mesh screen, and when crushing below  $\frac{1}{4}$  inch 77 per cent went through a 20-mesh screen. The latter was pyritic ore, which in a measure accounts for the increased quantities of fine particles. This is not unusual, and if dry crushing be practiced in a stamp-mill, a further percentage of the ore will be reduced to slimes.

Millmen understanding these features crush their ore as coarse as is consistent with good extraction by leaching.

As stated, the conditions that govern coarse crushing are porosity and roasting, so that from ores of the above description the best results are obtained. Ores

which are crushed fine or coarse as to that matter are but imperfectly leached unless sized, the solutions in such cases circulating in channels or between the larger particles rather than through the fine ore. If during the process of drainage much fine ore is present, it will prevent the operation, even when a vacuum filter-pump is attached to the vat.

In the latter case there are three methods of dealing with the problem, namely, separation of the slimes from the ore and treating each separately; agitation, by which means slimes and ore are treated together; and finally filter-press treatment, in which slimes only are treated.

**Decantation Treatment of Slimes.**—In this method of treatment the slimes are washed from the ore delivered to the tanks by the automatic ore-distributor mentioned in Chapter V. The water carrying the slimes is conducted to the settling-boxes, which are usually large pointed boxes arranged in series, the first box say 20'  $\times$  20' by 10' deep, the second 30'  $\times$  30'  $\times$  10' deep, and the third 40'  $\times$  40'  $\times$  10' deep. The heaviest slimes settle in the first box, the next heaviest in the second, and the lightest in the last. Slime settling may be hastened in some cases by the addition of lime-water, in others by alum.

The settled slimes are drawn off from the bottom and pumped into the first two of eight treatment-tanks,



about 90 per cent of the water from which they were settled having been separated.

The treatment-vats have a conical bottom, and more water having been separated from the slimes by allowing them to settle, they are sluiced into a pump by a jet of cyanide solution and transferred to a second series of vats containing 0.01 KCN solution.

About 80 per cent of the gold is dissolved in the passage through the pumps, but agitation is continued for about two hours by withdrawing the solution at the bottom and discharging it in oblique jets at the top and through the sides. The slimes are then allowed to settle, and the clear solution drawn off through side valves in the tank or by a siphon, and passed to the precipitation-boxes.

The residual slimes are then pumped in succession to the third and fourth series of two vats, where they are further agitated with very dilute solutions of cyanide and allowed to settle. These solutions do not pass to the precipitation-boxes, but are transferred to the preceding series of vats.

A somewhat similar method is practised in South Africa. The cost of pumping the solution for the purpose of agitation is about 10 cents per ton, with the total labor cost less than 25 cents.

The settlement of the slimes and the decantation of the water, which may be returned at once to the mill,

will lessen the consumption of water one half, if that is any object.

**Slimes and Water.**—Slimes will retain considerable more water than ore, and without recourse to a filter-press cannot be relieved of it. The space required for a mixture of slime and solution that weighs one ton is:

1	part	slime	to	1	part	solution	22.40	cu.	ft.
1	"	"	"	1½	"	"	24.32	"	"
1	"	"	"	2	"	"	25.66	"	"
1	"	"	"	2½	"	"	26.43	"	"
1	"	"	"	3	"	"	27.20	"	"
1	"	"	"	3½	"	"	27.28	"	"

**Filter-press Slime Treatment.**—The slimes are separated from ore by means of the automatic charging device and are settled in V-shaped boxes. The settled slimes are drawn off and agitated in mixing-vats for a time sufficiently long to dissolve the gold. The slimes are then run into a tank and forced by compressed air through the filter-presses. By this means 70 per cent of the solution is clear enough for immediate precipitation.

The slimes may also be washed in the press and the water immediately used if necessary for the next agitation.

It is claimed that dissolution of the gold will take place in the presses, but the proper treatment seems

to be to dissolve the gold by solution before it enters the presses.

**Agitation Processes.**—These processes are suited to clayey ores, and to them belong the Pelatan-Clerici, Gilmour-Young, and the Pneumatic processes.

*The Pelatan-Clerici* process is electrochemical and will be described in another chapter.

*The Gilmour-Young* process consists in grinding ore previously crushed to pass 30-mesh screen, in Boss amalgamating-pans.

The dry-crushed ore is charged into a pan in 2-ton lots, with 100 gallons of water, to form a very thick pulp. From two to six bottles of mercury are added until the globules can be seen circulating through the pulp, and then the required amount of cyanide is added. After grinding this for about two hours, 10 pounds of mixed zinc and copper amalgam are added, and the grinding continued four hours longer. By this time the precipitation of the gold from solution is very complete. The pulp and solution are then discharged into a settler, and the mercury recovered as in the ordinary pan process, that is, by the use of water and revolving stirrers.

It was found that while one hour was sufficient to reduce the gold in the slimes, the sands required a longer treatment. They are therefore separated from the slimy pulp and given a 4 days' percolation treat-

ment. The extraction obtained is said to be 90 per cent gold and 80 per cent silver, with a consumption of  $1\frac{3}{4}$  pounds of cyanide. The process has many disadvantages, among which may be placed cost of chemicals, impure bullion, and the power required. The latter amounts to about 2 horse-power per ton of ore treated daily.

The advantages are that the amalgam is retorted, and tests can be readily made in a pan at any time.

There is considerable loss of mercury in pan amalgamation, and it is not probable that less loss will occur in this treatment; this loss must be added to the cost of treatment. The process is practiced at the Santa Francisca mine, Nicaragua, and may eventually develop into an extremely useful method of extracting gold from certain ores.

From its description and the list of chemicals, which are cyanide, caustic, copper sulphate, cast-iron turnings, zinc, and mercury, it seems to be an Arrastra-Patio-Boss-Freiberg-Cyanide process, and under such conditions the extraction should be high, if costly.

*Pneumatic Cyanide Process.*—Agitation by means of compressed air is one of the oldest methods of washing phosphate rock. As a means of supplying oxygen to solutions of cyanide and ore it has been patented, but this patent does not seem valid to the writer, who at one time before the present patents



were granted went into the subject of this process thoroughly. Any one has the right to agitate ore by compressed air, and that it supplies oxygen during agitation follows naturally. In order to patent compressed air as a means of supplying oxygen one must go behind the returns and prevent agitation. Nevertheless there is a patented pneumatic cyanide process, and while it has not superseded the other processes it is as good as, and in some cases better than, they are.

The process as outlined consists of steel vats, connected near the bottom by pipes, and by means of a tee with a pipe running over the vats. From the pipe running over the vat two pipes extend down into the tanks, in such a way that air will be forced into the pulp and, bubbling up, will agitate the mass. It is claimed that this arrangement will do in seven hours the leaching that formerly required from two to six days.

## CHAPTER X.

### ELECTRICITY APPLIED TO CYANIDING.

**Introduction.**—Mr. MacArthur said that “when cyanide is used in combination with the electric current not only is there a larger expenditure of chemicals, but the base metals are dissolved to a large extent along with the gold and silver, and for subsequent separation involve extra expense, which is saved by our process.”

Mr. Hanny, a countryman of his, says that “when the electric current is used the cyanide solution may be weaker, as its action is increased by the current.” He further states that “only gold and silver salts are attacked by the solution, and that copper and iron pyrites may be stripped of their gold and not be attacked otherwise.”

According to Berzelius, “Chemical union of any two substances is an electrical act; that during contact previous to union the one substance is relatively positive, the other relative negative, and the act of union is a consequence of the attraction existing between the

substances in these two states; also that in the act of uniting the two electrical conditions neutralize each other and produce heat.”

As MacArthur and Forrest were the parties to introduce the practical application of cyanide to extraction of gold from ores, Siemens-Halske may be considered the first to introduce electricity into the process to assist its application. Neither of them designed or produced anything new, but, having faith in their experiments, they applied their capital to obtain useful results.

When Dr. Siemens took the matter up, he found that electrical precipitation was equally effective with either strong or weak cyanide solutions. This was one step in the right direction, namely, a saving in chemicals.

Julian Rae of Syracuse, N. Y., patented an apparatus as early as 1867 for the electrical precipitation of gold from ores, but the patent, like Simpson's of 1885, seems to have been left on the shelf to mould. Mr. Rae did, however, make one practical test, at the Douglas mill, Nevada, which was not entirely satisfactory. His failure to obtain uniform results was due to his using an alternating current. Electrolysis with such currents must necessarily be very slow, and the slower the reversal of the current the better the results, for if the current alternates quickly there will not be

given time enough for the solution to deposit its metal compound before it is repelled by a reversal of the current.

Wm. Crookes (patent No. 462,535, 1891) says: "In carrying out my combined process I take the gold ore, tailings, etc., and mix with them a solution of nitrate or cyanide of mercury, and pass a rapidly alternating current of electricity through the mass, either when at rest or agitated in any manner."

"The bulk of the mass is not a good conductor of electricity, while the fine particles of gold are excellent conductors." "Iron or carbon can be used as electrodes, and each electrode is alternately anode and cathode." "Assuming that sulphate of mercury is the mercurial salt, the current liberates sulphuric acid at one pole and mercury at the other." "The action now being reversed, the mercury liberated previously has a molecule of acid to unite with it, so that at each pole the mercurial salt is decomposed only to unite again." "Since the gold in the wet mass is a better conductor than the surrounding mass, the equipotential lines of force will converge toward them, so that more of the current passes through them than the rest of the mass, and the two sides of each particle of gold act as anode and cathode. On one side sulphuric acid is liberated, on the other mercury, but the affinity of gold for mercury is so great that they instantly amalgamate



on one side, finally on the other side. Thus the size of the particles is not essential, as the finest flour and float gold will be amalgamated. Nor does it matter to what degree of coarseness the ore is crushed so long as the mercurial salt penetrates to one part of the piece of gold locked up in the ore, for the action will then take place and the metal become amalgamated."

"The advantage incidental to the use of an alternating current is that the sudden and violent decompositions and recompositions cause the mass to become hot, and so greatly facilitate amalgamation."

"The efficient action is dependent upon several variable factors, viz., current density, area of electrodes, rate of alternation per second, and electric conductivity of the crushed ore and liquid."

There is no record that this process has had practical application, but there is a record made by Mr. Rae, who used an alternating current and mercury cathode, which indicates strongly that it will not be a success. It is mentioned here because of its connection with electrical cyaniding operations.

**Electrolysis.**—If a metal is in solution as a chemical compound, it may be separated and deposited as a pure metal by passing an electric current in such a manner that the solution acts as a conductor of electricity. The essential conditions necessary for electrolysis are that the substance be a liquid, a definite

chemical compound, and a conductor of electricity. When aurio-potassic cyanide delivers up its gold to zinc as explained, it would be converted into caustic potash, did it not have a definite chemical composition of its own that could unite quickly with the zinc liberated. But the interchange of gold for zinc is the result of electrolysis, and the formation of zinc-potassic cyanide is a secondary product of electrolysis. In passing a current through a solution (which is termed an electrolyte) it is customary to partly submerge two metals in the solution. That metal by which the current enters the electrolyte is the anode, and is more or less dissolved during the operation, oxygen being liberated at this pole.

That metal by which the current leaves the electrolyte is the cathode, and is not so badly eroded as the anode, although metal from the solution is deposited upon it and hydrogen is liberated at this pole.

At the anode, also called the positive electrode, the solution is broken up into what are termed ions, and as they are charged with positive electricity they are repelled and move towards the negative electrode which attracts them. Such ions are termed anions.

Anions when they reach the negative electrode are broken up and deposit their metal, while the chemical portion of the anion receives negative electricity and is

repelled by the cathode. This ion is termed a cation. The anions move directly towards the cathode, and the cations towards the anode, thus forming an electric circuit, for the transmission of the current. It is known that an electrical current will pass through an electrolyte when it is so feeble as not to cause electrolysis; consequently, in order to deposit a metal, there must be a definite amount of electricity passed. Not only precise quantities of current, but definite amounts of electrical energy, are required to separate definite weights of substances, and this amount of electrical energy depends upon the strength of the chemical union of the compound, upon the chemical equivalent or valence of the element to be separated, and upon the amount of the conduction resistance of the electrolyte. It is not misdirected currents of electricity, however great, that separate reducible elements, since from a weak solution of a potassium salt even the strongest current will not deposit the metal; but by using a cathode of mercury of small surface the metal has been deposited by the aid of a feeble current. It thus becomes evident that the energy must be intelligently directed. If there is an impure anode of copper submerged in sulphuric acid containing copper sulphate, the anode will be dissolved and the copper deposited pure, while the impurities from the anode will fall to the bottom of the tank or be dissolved by

the electrolyte. It is not necessary that the anode be copper; any other metal will act in a similar manner, and be deposited, provided the solution contains sufficient metal salt and not too much free sulphuric acid.

The anode of copper will be dissolved and in time weaken the solution unless more copper sulphate is supplied before that point is reached. Other metals than copper can be deposited from suitable solutions by an electric current; in fact several metals may be in solution and but one deposited, that being the most electro-negative; but in all cases the quantity of metal deposited will be proportional to the quantity of current multiplied by the time it has been flowing.

A relation exists between the amount of metal deposited by a current in a given time and the atomic weights of the element. This is proportional to the atomic weight of the metal divided by its valence. For example, from a solution of silver cyanide in potassium cyanide there will be deposited 108 grams of silver by the same current which would liberate 1 gram of hydrogen in a given time, or

$$\frac{\text{atomic weight}}{\text{valence}} = \frac{108}{1} = 108.$$

Or, in the case of cyanide of gold in a solution of potassium cyanide (the valence of gold being 3),



$\frac{196.7}{3} = 65.56$  grams of gold will be deposited in the same period and with the same current that would liberate 1 gram of hydrogen.

**Current Strength.**—When one practical unit quantity of electricity is flowing through a conductor every second, the strength of the current is one ampere. It makes no difference in the number of amperes whether the current flows for a long time or only a fraction of a second; if the quantity of electricity that would flow in 1 second is the same in both cases, then the strength of the current in amperes is the same.

A current of electricity in passing through water will decompose it into its two elements: hydrogen will be liberated at the cathode and oxygen at the anode. The quantity of water decomposed is proportional to the strength of the current flowing, and also to the time during which it flows. This fact has been adopted as the basis for a unit strength of current, that is, one that will decompose a certain quantity of water in a stated time, say 1 second.

By universal agreement 1 ampere is that strength of current which will decompose .00009324 gram or .0014388 grain of water in 1 second. If a current of one ampere flows continuously for one hour, it is termed an ampere-hour; if 2 or more amperes flow continuously, there are said to be 2 or more ampere-

hours. The number of grams of silver that would be liberated in an ampere-hour may be found as follows:

$$\frac{.00009324 \times 3600}{9} \times \frac{107.66}{1} = 4.0264 \text{ grams.}$$

The number of grams of gold that will be deposited in an ampere-hour may be found in a similar manner, the  $\frac{1}{3}$  representing the proportional part of hydrogen in water according to the molecular weight theory, thus:

$$\frac{.00009324 \times 3600}{9} \times \frac{196.7}{3} = 2.4519.$$

**Voltage.**—In all electrical problems there are two properties of the current to be considered: the number of amperes of flow, and the volts or pressure. There is a definite amount of voltage for every element, and no current will pass through an electrolyte until this voltage has been reached.

This pressure is intimately connected with the heat of combination or chemical affinity, and must be determined for any electrolyte by experiments in the laboratory.

In voltaic cells each metal of the couple is corroded and evolves heat; but the highest electromotive force is obtained by coupling two elements widest apart in the voltaic-tension series; that is, other things being equal, the most easily corroded metal, coupled with

the one least easily corroded, yields the most intense current.

The volt is the practical unit of electromotive force, and may be further defined as that electromotive force (E.M.F.) which will cause a current ( $C$ ) to flow against a resistance ( $R$ ) of 1 ohm. To measure the amperes and volts, ampere-meters and volt-meters are necessary.

**The Ohm.**—The resistance which the electromotive force must overcome to produce a current sufficient to flow through an electrolyte is measured in *ohms*, or the practical unit of electrical resistance. The ohm has several values, but the legal ohm is the resistance offered by a column of mercury 41.7323 inches high, having a cross-section of .00155 square inch, at a temperature of 32° F. Ohm's law is expressed as follows:

$$\text{Strength of current } (C) = \frac{\text{electromotive force } (E)}{\text{resistance } (R)}.$$

When the values of any two of these quantities are known the others may be found by transposing, thus:

$$C = \frac{E}{R}; \quad E = CR; \quad \text{and} \quad R = \frac{E}{C}.$$

**The Watt.**—Horse-power expressed mechanically is 33,000 foot-pounds per minute or 550 foot-pounds per second. The watt is equivalent to .7373 foot-pound

per second, or  $\frac{550}{.7373} = 746$  watts as an electrical horse-power. The watt is also the product of amperes by volts, that is,  $W = EC$ , and hence  $W = \frac{EC}{746} =$  electrical horse-power.

With the elements of the electrical actions and units understood, the reader will be able to follow the reactions which must occur in electrolysis.

**The Electro-cyanide Process.**—The ideal electro-cyanide process should conform to the following propositions:

(a) The precious metals are to be extracted direct from the ores, and be precipitated in such form that they can be readily recovered and refined into fairly pure bullion.

There must be economy in the use of potassium cyanide, and it is known that under certain conditions there is a nearer approach to theory in the consumption of cyanide by the combined action of electricity and potassium cyanide than by cyanide and zinc precipitation.

(b) The process should dissolve and precipitate the precious metals, so that the bullion may be recovered the same day, thereby effecting a saving in time, but the cost of so doing must not exceed that of ordinary leaching.



(c) The process must treat slimes, discharge the vat, and allow the solution to run practically free from gold out of the vat; in other words, the exhausted solution should contain less than 50 cents of gold in one ton.

**Electricity and Oxygen.**—Electricity in the leaching-vat should hasten the dissolution of gold in a cyanide solution, since oxygen, the much-needed element, is given off at the anode. In case agitation is applied in conjunction with electricity there will be two sources of oxygen. There seems to be some question as to the manner in which the cyanide solution is increased in dissolving power by becoming an electrolyte, but it must be evident to the reader that such is the case, although somewhat surrounded by reactions not definitely understood.

Text-books on electrolysis state that the chemical changes directly produced do not take place in the mass or body of the electrolyte but at the electrodes, and are strictly limited to thin layers of metal and liquid in immediate contact with each other. The ions formed at the anode move in the direction of the cathode and serve as carriers of the cyanide of gold molecule, never being in a free state until they reach the cathode. In the Siemens-Halske precipitation process the solution is comparatively free from solid matter, and at the same time the anodes and cathodes are close to each other.

The solution is allowed to pass slowly by these electrodes, and consequently the anions are attracted and the gold liberated from solution. In the Pelatan-Clerici process the ore and solution are in contact with the electrodes, which are a considerable distance apart, and in this process the ions cannot travel in one direction on account of the disturbance caused by the agitator.

It is probable that the potassium cyanide and gold form the double salt  $2\text{AuK}(\text{CN})_2$ , independent of the electrodes, and that on coming in contact with the anode the potassium is liberated, the ion being  $\text{Au}(\text{CN})_2$ , which, charged with positive electricity, goes to the cathode only as agitation permits. Whenever one of these cyanide-of-gold molecules comes in contact with the cathode it is immediately broken up and the gold deposited, while the chemical, cyanogen, is liberated.

As the cyanogen will always find hydrogen at the cathode it will be converted into hydrocyanic acid, which cannot remain inactive, and will combine with the potassium hydrate to form potassium cyanide.

It is difficult to account for the reactions which occur in the Pelatan-Clerici process except upon the grounds given. The reactions may be formulated as follows:

In the solution

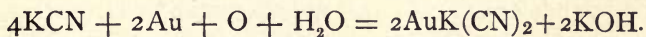

At the anode oxygen is given off in the presence of water, hence

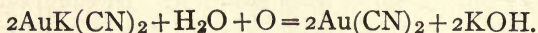

At the cathode hydrogen is liberated in the presence of cyanogen, therefore

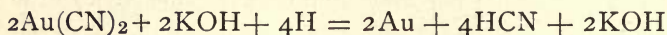

and, the gold being deposited,

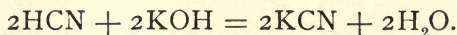

This is the regular reaction independent of the part the electric current plays in hastening the process. If the latter acts as stated, it must be by furnishing oxygen for the process and then immediately converting the aurio-potassic cyanide into cyanide of gold. Pelatan and Clerici use for an electrolyte sodium chloride in order to have a freer passage for the current, and thereby counteract the resistance which would, it is claimed, take place with such a poor electrolyte as potassium cyanide alone. This they claim is to form a definite chemical compound, but, as stated, potassium cyanide also forms a definite chemical compound, besides is divisible into a great many molecules and still be potassium cyanide and a definite chemical compound, capable of transmitting an electric current more readily than water.

The conductivity of a solution depends upon the number of free ions in it; in other words, on the extent of dissociation; and it is known that it is a difficult matter to deposit potassium electrolytically except on a cathode of mercury of small surface. It may be argued, therefore, that while a weak current could precipitate potassium from the solution, it will not do so as long as gold is present in the solution, as the chief amount of conduction resistance is in the electrolyte, and not in the electrodes, and since by a rise of temperature the resistance of the liquid is decreased the effect is to facilitate electrolysis. At the same time this rise in temperature should increase the solubility of the solution.

The amount of energy required to separate gold from auro-potassic cyanide depends upon the voltaic tension between potassium and gold, which is considerable; hence the energy required is not great. The amount of energy required to separate gold and cyanogen is more on account of their nearness in the voltaic-tension series, but it also depends upon the solubility of the anode, for which reason an easily soluble anode must be chosen.

The datum which must be known for the successful practice of electro-cyaniding is the percentage of gold to be dissolved. The amount of cyanide must be based upon this quantity of gold, and then the neces-



sary current calculated for precipitating the gold in a given time.

Every electrolyte must be electrolyzed at a particular rate in order to continuously obtain from it the desired quantity of metal. This latter datum can be obtained from a few experiments, and then tables computed to fit every possible case, care being taken to use only sufficient current to accomplish the work; otherwise there will be a waste of power, injury to the electrolyte, and a deposit of impure metal.

## CHAPTER XI.

### ELECTRODES.

**Electro-gilding** has been in use over half a century. Dr. Wright of Birmingham, England, used gold cyanide solutions for electro-gilding in 1840.

The principle is that of depositing gold from solution upon a cathode of metal to be plated.

The current or circuit is made so that electrical action must take place between the electrodes through an electrolyte. The current decomposes the liquid at the cathode, liberating the metal from its chemical combination.

Elsner's equation has with electrical action the same features that it possessed where potassium cyanide and zinc precipitation was employed. The oxygen decomposes the potassium of the auro-potassic cyanide salt as before, except more briskly.

In this instance agitation is not as important for generating oxygen as it is for moving the ore and liquid so that the electrolyte can come in contact with the electrodes, in one instance receiving life for dis-

solving, in the other delivering up its metal and becoming regenerated, and sent on its way to dissolve more gold.

With electrical action the potassium cyanide can be greatly reduced in the solution. As stated theoretically, 1 part of cyanide should dissolve 1.5 parts of gold, but practically it requires from forty to sixty times that quantity.

By the aid of electricity in connection with cyanide the amount of the latter needed has been reduced to 16 parts cyanide to 1 part of gold dissolved, and there are good grounds for belief that it will approach nearer the theoretical limit.

As the solvent action takes place very much quicker, and as there is not the same loss of cyanide as in percolation and zinc precipitation, a very great saving in time and expense should be recorded.

The liquid remaining after leaching will not contain impurities injurious to future leaching when electro-cyaniding is practiced.

Agitation with an electric current passing is not as important as in the former practice, nor would it be as far as oxidation and precipitation go, but there are other considerations which make it desirable that the sludge be kept in motion.

The solution is very weak, and in order to hasten its action mechanical power should be used. While it

is possible that the liberation of gases and the action of gravity due to different densities in the electrolyte, either with or without gold in suspension, would create circulation, still the fact is that the sludge would settle around and on one or more of the cathodes, thus hindering, if not entirely stopping, the deposition of the metals on the cathode. Were the liquid clear or filtered from the sludge, this would not be the case, but by filtering time is lost and the cyanide cannot do the work as readily as it is accomplished by agitation.

The chief objects in the use of electricity are to save time, cyanide, and zinc; to do away with several tedious filterings or percolations, as they are called; to do what leaching is required with one solution at one time; and precipitate the gold at the same time that the operation is carried on in the vat. To accomplish this the apparatus must with the solution satisfy the following condition: First there must be a metal anode not easily corroded or dissolved by the solution. The proper position of this anode is above the cathode; but it can be parallel to it if both are perpendicular. When horizontal and in courses, the oxides from the anode fall away, and being deposited on the cathode will interfere with its action, especially if they can unite chemically with it. Secondly, the cathode must allow the gold to adhere to it, and after the process is completed allow the metal to be easily recovered.

When the gold must be dissolved from the cathode by acid, such sheets of thin metal as can be readily removed from the vat should be used; the thin gold can then be removed by scraping the plates. These plates should also be arranged so as to be easily lifted out and returned to the vat, or if mercury is used it must be arranged to run off readily so that it can be strained and returned to the vat. Each inventor has the best mode of accomplishing these results, or at least did have until some one else overtopped him.

As power must be used for agitation, it must be sufficient and applied in such a manner as to stir up the whole mass and keep it in motion. The anode being the dissolving-point and the cathode the receiving-point, if the power be applied to either one, that is, the mechanical power for agitation, it should be applied to the anode. If this power can be applied to either electrode, matters have been simplified one step more by lessening mechanical complications.

The best way to recover the precious metals is in the form of amalgam, if it can be accomplished.

When considering electrodes the position in the voltaic-tension series is important, for if a readily dissoluble anode is used with a cathode not easily effected by the current and solution, the ideal voltaic couple is approached; but in this case such anodes are not



highly desirable, as they are expensive and foul the solution.

It becomes necessary also to consider the cathode, for in some cases the metal will not adhere, in others it will adhere too firmly, and again it will be in such a powdery condition as to fall away from the cathode and become mixed with the sediments in the bottom of the tank.

The electrodes are then matters of no little importance in the electro-cyanide process. The current strength has much to do with the life of electrodes, for if more current is used than is necessary they will be wasted. In copper refining the electrodes are given the same superficial area as nearly as possible, the object being to afford as much dissolving as depositing surface, that the deposit may be uniform. In electro-cyaniding this is possible only where the electrodes are stationary, but where the movement of one of the electrodes occur this may not be practicable. Again, it is stated on the results of experiments that where mercury is the cathode, it should be sometimes quite small. The reduction in the size of either electrode is similar to adding resistance to the passage of the current, and, as von Gernet says, "a better effect is produced by doubling the surface of electrodes than by increasing the current tenfold."

In using an iron anode and a lead cathode for the

purpose of depositing gold from a cyanide solution, it was found that a 5-H.P. engine yielded  $3\frac{1}{2}$  H.P. electrical energy at 4 volts pressure. This is equivalent to  $W = EC$ , or

$$C = \frac{W}{E} = \frac{746 \text{ watts} \times 3\frac{1}{2} \text{ H.P.}}{4 \text{ volts}} = 652.75 \text{ amperes.}$$

It requires a definite amount of current to oxidize a definite amount of iron, and in this instance 1080 pounds were oxidized in a month; the gold precipitated in that time was 335,935 grains in 700 hours, or 4709 grains per hour. According to the gold ampere-hour of 38.1 grains it requires 8817 ampere-hours to deposit this amount, but 210,000 ampere-hours were expended or 201,283 more ampere-hours than were required. The current necessary to deposit this amount of gold was 12.6 amperes, hence the efficiency of the current was  $\frac{12.6}{300} = 4.2$  per cent,

because 300 amperes were actually used. The remainder of the current was wasted energy, and was expended upon the iron, which diluted the electrolyte by forming Prussian blue, as well as being dissolved.

There must be a certain amount of energy, but not too much. The amount should be determined for the work to be performed. If to-day a two-ounce gold ore is to be treated in ten hours, more amperes will be

required than if a one-ounce ore were to be treated to-morrow in the same time, and the oxidation of the anode will not be more, since surplus energy has not been expended upon it.

As stated, the electrodes should be as nearly of a size as possible when uniform results are to be obtained. They should be, especially the anode, of a metal or substance not easily acted on by the solution; iron seems to be suitable to fulfil the conditions of the anode, as it is not readily acted upon by the solution, and when oxidized it is due in great measure to having the current too energetic for the work in hand.

The question of the size of anodes and cathodes, that is, the surface exposed where agitation is used, especially iron and mercury, is purely theoretical. The anode in some cases is not more than one third the surface of the cathode, and yet the iron anode is not very materially oxidized. This may be due to the movement of the anode, which rotates horizontally over the cathode of mercury, but at some distance from it. However, it does not seem possible that this rotation has much to do with it, since the current is continuous, and the voltmeters and ampere-meters do not show any variation of importance. One would suppose that energy would be expended more upon this small anode, but practice shows it is not.

The electrolyte seems to be a good conductor of the

current, and not being often in a state of a metallic ion on account of gold being so widely distributed, nevertheless it conducts the current, when proportioned rightly for the work, to the anode and cathode, fairly well. While the heat arising from conduction resistance throughout the electrolyte naturally reduces the resistance, it is small, and that leads one again to presume that potassium cyanide with pulp is a fairly good conductor. The quantity of energy lost by the corrosion of the cathode is very small.

The electrolyte must be a liquid, a definite chemical compound, and a conductor of electricity. It is considered in electrolysis that an electrolyte must have a constant composition, whereby the proper working conditions may be constantly maintained; in other words, to make gold deposition by electricity practicable, there should be a soluble gold anode. This point is not well taken, for the process has been worked satisfactorily day after day with a weak gold solution and an iron anode.

It is true the electrolyte is changed chemically by the passage of the current, but in any case the potassium and cyanide remain in some form in the solution. It is true that the electrolyte may offer a high specific resistance; but it is more than likely that impurities in the liquor assist in a measure the passage of the current, or they may be introduced artificially to assist

it, as, for instance, in the Pelatan-Clerici process, about 1 per cent of common salt (NaCl) is placed in the bath, for no other purpose than to give the electrolyte a sufficient and practically constant conductivity during the whole operation. If other impurities in the liquor assist the passage of the current, so much the better; if they retard it, their effect is not noticeable.

With such a feeble current as is generated in the zinc-boxes the strength of the cyanide solutions is of considerable moment, but when electricity is applied to weak cyanide solutions the strength of the solution is of very little moment.

The potassium cyanide is separated into an acid and a base by the current, the electromotive force necessary to produce decomposition being much less than that to set free the alkali metal.\* If the theory advanced be correct, and it evidently is from a scientific standpoint, there is KCN regenerated as soon as the gold is deposited, and this has the effect of keeping the electrolyte in good condition for the passage of the current irrespective of the addition of salt. Again, instead of a soluble anode of gold there is gold in the solution being dissolved, and this in a measure takes the place of a gold anode, especially when broken up from the aurio-potassic cyanide salt to aurio cyanogen.

---

\* Journal Chem. Soc. 1882, vol. xliii. pp. 260, 283.



## CHAPTER XII.

### THE CURRENT.

PROFESSOR BUNSEN stated "that electrolysis in all operations marked a great advance on chemical action pure and simple," but he should have added that the value of any metallurgical process depends upon the size of the dividends.

The cost of the current has much to do with the installation of an electro-cyanide plant. In some instances where water-power is available the cost will be merely nominal, but where fuel is high for generating steam the cost will be an item of importance.

The quantity and energy of current required for the electro-cyanide process are variously stated, in one case a current of 0.05 amperes per square foot of cathode surface being sufficient with 7 volts, or the equivalent of 5.7 H.P. for a cathode surface of 12,000 feet. This should deposit 1471.14 grams per hour. In another case 0.35 ampere per square foot was sufficient with 5 volts pressure to carry on the operation with 60 feet of cathode surface. This is equivalent to  $\frac{1}{7}$  H.P., and should deposit 51.49 grams per hour.

It is only possible to obtain the amperage and voltage necessary for a given electrolyte by experiment, but after a series of experiments a table may be calculated based upon the quantity of gold to be dissolved in a given time. Suppose there are 32 grams of gold per ton of ore and 64 grams of silver per ton of ore in a charge of 10 tons, and it is desired to precipitate this in ten hours, it will require

$$\frac{320}{2.4519 \times 10} = 13 \text{ amperes for gold}$$

and

$$\frac{640}{4.0264 \times 10} = 15 \text{ amperes for silver.}$$

Adding the two together gives the number of amperes per hour required theoretically; in practice, however, it is well to double this number. It is also well to verify this in order to find out that the amperes are not too high for the anode, as the number of amperes should not exceed 3 for each square foot of anode surface; should it be more, it would be better to lengthen the time of precipitation or use a smaller quantity of pulp.

**Voltage.**—The voltage in any case should not be less than three, but the exact number can only be found by experiment. It is a good plan to examine the connections often, at least once a week, testing the resistance of the wires, cathodes, and anodes.

It is also a good plan to have a dynamo which can give 2 or 3 volts more than the number calculated, for probably there will be a loss of potential equal to that number.

**Calculation of the Wires.**—The formula is derived from Ohm's law and is

$$s = \frac{cla}{v};$$

in which  $s$  represents the cross-section of the wire;  $l$ , the total length in meters;  $a$ , the number of amperes;  $v$ , the loss of potential (2 volts);  $c$ , the coefficient of resistance, which for copper is .00018. The section  $s$  is in square millimeters.

The quantity and the energy of current required for the electro-cyanide process of dissolving gold and silver from their ores are variously stated.

If in a fixed time a given electric current will deposit a certain quantity of metal, it will be in direct proportion to their electro-chemical equivalents. "This law holds good only for solutions strong in metal; but with the dilute solutions used in the cyanide process the current does not find sufficient of the metallic compound present at the electrodes, and consequently decomposition of the water takes place. For the purpose of making the efficiency of the precipitation as great as possible constant diffusion of the solution is requisite." (Von Gernet.)

**Cost of Electric Cyaniding.**—To decompose gold salts and deposit gold requires theoretically 0.4 of a volt, but owing to various resistances to be overcome assume that it is 7 volts when a gold anode is not used.

A current of 7 volts and 500 amperes represents about 4.6 H.P., costing, say, \$1.84 per day of twenty-four hours. This current, in a solution for gilding purposes, where the whole of the amperage is used to precipitate the gold, would deposit  $2.4519 \times 500 = 1225.95$  grams per hour, which, reduced to pennyweights, gives practically a deposit of \$780 in gold per hour, or \$18,720 per day. The cost of electricity consumed would therefore not be more than  $\frac{1}{18000}$  of the value of the gold. If, in order to precipitate gold, zinc is used, there will be a consumption of 1.39 pounds per ounce of gold recovered, costing, according to Bosqui, 18.4 cents. To precipitate with electricity 780 pennyweights of gold as in the above case for comparison, the cost would be \$71.76.

In the Siemens-Halske process the consumption of lead amounts to 3 cents per ton of tailings containing 8 pennyweights of gold, or about 8 cents per ounce of gold deposited, or \$23.40 in comparison with \$71.76 for zinc. The total cost of precipitation by the Siemens-Halske method would be  $\$23.40 + \$1.84 = \$25.24$ , irrespective of the reduction in cost of refining the bullion. With the Pelatan-Clerici process the cost

would be more marked, because the cost of depositing includes a reduction in cost of leaching and precipitation; in other words, when considering \$1.84 as the cost of precipitation, the cost of agitation is included, as practically none of the cathode is lost when the work is properly conducted.

The cost of anodes in the above instance has not been included, but it is less than 1 cent per ounce of gold recovered.

**Objections to Electro-cyaniding.**—Naturally there are objectionable points to electro-cyaniding, some of which are well taken, while others are more imaginary than real. Among the objections is the formation of ferrocyanhydric acid, which might assimilate with aurocyanhydric acid. One of the essential characteristics of ferrocyanides is that by adding to them a salt of another metal the iron is not displaced and no cyanide of iron is separated; hence it matters little about aurocyanhydric acid, as it will not be assimilated by ferrocyanhydric acid and can be gotten rid of by using a sufficiently strong current.

The case is different with the double salt of cyanide of gold and potassium, and for aurocyanhydric acid, since chloride of mercury separates the gold; silver nitrate precipitates the gold entirely, and mercury, lead, and zinc act partially in the same manner, namely, by substitution.



## CHAPTER XIII.

### ANODES.

**Platinum Anodes.**—Julio H. Rae patented the use of a platinum anode in 1867. This metal offers great resistance to the passage of an electric current, consequently is objectionable on account of the electromotive force required and also its great cost. Owing to the fact that decomposition must take place at the anode of the electrolyte, energy is expended not on the work, but in setting free oxygen that will probably decompose the electrolyte, particularly if it is potassium cyanide. The amount of platinum which should be liberated in an ampere-hour is

$$\frac{196.7}{4} \times \frac{.00009324}{9} \times 3600 = 1.835 \text{ grams,}$$

or about three fourths as much as gold. Other inventors do not coincide with Mr. Rae in suggesting this metal as an anode, due more probably to its cost, which would be exceedingly great in a plant of any size.

**Carbon Anodes.**—In the Siemens-Halske process carbon was experimented with for anodes, but since it

could not withstand the action of the current it was abandoned.

Carbon is suggested by Malloy's process, patented in 1884 and 1886. In this case, as with platinum, oxygen escapes. The carbon is, however, practically unacted upon chemically, but the current or the oxygen mechanically disintegrates the carbon, and the stronger the current the more rapid the disintegration becomes.

It is further objectionable because of loss in current, energy, and possibly the active energy of the electrolyte.

Eissler in speaking of the Siemens-Halske process says: "Carbon could be used as an anode, but will not stand the action of the current, and soon crumbles into a fine powder which decomposes cyanide." "This finely divided carbon is in suspension, and cannot be removed from the solution by filtration." On the other hand, Mr. Weightman used arc-light carbons for six months, and they were at the end of that time in good condition. Mr. Weightman's observations do not agree with Mr. Eissler's, but that is not due to error on either side. One undoubtedly had reference to porous carbons while the other had reference to dense compact carbons coated with copper. The copper coating was of very great assistance even to the compact carbon in counteracting disintegration

by the current. The great objection to carbon is its lack of conductivity; if silver be 100, then carbon as graphite is .069, and as gas-coke .038. A disadvantage in its use is its small power of dissolution, which is but 1.74 ampere-hours; hence it could cause little deposition without great electrical energy.

H. R. Cassel used carbon rods as anodes, as did Fischer and Weber (patents 1883, 1885, and 1887). J. B. Hanney used a mixture of plumbago and resin as anode, and, as he claims, with very good effect. As a rule, the anodes in the various processes have been varied but little, but in some patents they have been differently arranged, so as not to conflict.

**Zinc Anodes.**—The rate of dissolution of zinc by an electric current is  $\frac{65}{1} \times \frac{.00009324}{9} \times 3600 = 2.424$  grams per ampere-hour, or about the same as gold, and, being quite electropositive, would make an exceptionally good anode from an electrical standpoint but an exceedingly bad one from an electrometallurgical view.

Zinc as an anode has serious defects, in fact as numerous as when used as a cathode. It forms a precipitate of cyanide of zinc in the solution; also zinc oxide on its surface, which offers resistance to the electromotive force, making it expensive. Should it precipitate on the cathode, it will also cause future

annoyance. One of the advantages claimed for electrolysis is that it does away with zinc impurities, should zinc be considered at all in connection with electrolysis, the process will have gone backward instead of forward.

Zinc will cause the solution and deposition of 18.95 grains in one ampere-hour; hence it is only slightly better than iron as a conductor, while very much inferior as far as by-products from the operation are concerned.

**Iron Anodes.**—The rate of dissolution of iron by an electric current is  $\frac{56}{4} \times \frac{.00009324}{9} \times \frac{3600}{1} = .596736$  grams per ampere-hour. Wrought iron and steel anodes when not high in carbon are more readily oxidized than cast iron, and form Prussian and Turnbull's blue in a bath of potassium cyanide.

Iron has, however, been adopted as an anode because of its cheapness, and because of its being little acted upon by cyanide of potassium solutions. While iron might be improved upon if cost were not an item, it is a difficult matter to find a substitute which may be handled and obtained so economically at present.

It would be of very great assistance in a discussion of this kind if data similar to that of copper refining by electrolysis were available, but there are no such data. In the Pelatan-Clerici process the anode is

steel boiler-plate, about one third the size of the cathode, which is 60 square feet. Because of the revolving motion of the anode a larger size is not deemed necessary. In the Siemens-Halske process the anodes have one seventh larger surface area than the cathode and are of cast iron.

The anodes in the Pelatan-Clerici process are from 4 to  $4\frac{1}{2}$  inches away from the cathodes; in the Siemens-Halske process there are  $1\frac{1}{2}$  inches between the anode and the cathode.

In the Moebius process of electrolytic silver-refining the anode and the cathode are not over  $1\frac{1}{2}$  inches apart, and precipitation is rapid.

That the Pelatan-Clerici anode is too small would be the natural conclusion were it not that under the management of Mr. Clerici the percentage of recovery, with favorable conditions, was as great as that of the Siemens-Halske process.



## CHAPTER XIV.

### CATHODES.

CATHODES for the electro-cyanide process are as important as anodes, as upon them the metal from the solution is to be deposited.

The cathode must be plated with metal in such a manner that recovery from it will not be difficult. Some cathodes will not allow the gold to adhere; some will convert it into amorphous powder; others will cause it to curl up and fall away; consequently the choice should be one which will permit the metal to adhere.

The cathode must be a good conductor of electricity and not easily corroded by the solution, although as a rule coatings are less frequent on the cathode than the anode; still there is apt to be some, and that, with the hydrogen which adheres to it, will diminish the current.

The density of the current will regulate the deposition of the metals, also the form in which they are

deposited. With compound substances the cathode should be of such a nature as not to unite readily with the secondary products of electrolysis. From an impure solution the least electro-positive metal should be deposited upon the cathode first; consequently with a solution containing gold and potassium cyanide, silver and potassium cyanide, as double salts of cyanide, the order of deposition would be silver, gold, potassium; but it is doubtful under these conditions whether it is necessary to use a current more than sufficient to liberate the gold and silver, allowing the KCN to remain in solution undisturbed. If this can be accomplished, there will be considerable voltage saved as well as cyanogen.

It is known that an electrical current will pass through an electrolyte when it is so feeble as not to cause electrolysis, and that aqueous solutions of the zinc and copper cyanides will dissolve and deposit equally on passage of suitable current. So one is led to infer from these phenomena, since the electromotive forces of zinc and copper are equal, that the least abundant metal will deposit least; but if equally solvent in the solution, the least electropositive will deposit first, and this latter has been proven in the case of silver salt in copper solution, and is the case in potassium cyanide solutions containing gold and silver. The size of the cathode should be larger than the

anode if its conductivity is less, but may be smaller if its conductivity is greater. It should be of sufficient size, however, to be able to absorb or receive as much metal as is offered for deposition.

**Copper-plate Cathodes.**—Copper plates as cathodes for gold are not a success, because gold either adheres too firmly and is difficult to remove, or it does not adhere at all. These conditions depend upon the strength of the current. Sheets of copper coated with mercury have been used, but, owing to the action of the current, the mercury penetrates the copper, forming a dry amalgam which does not adhere to the plate. This latter objection may be overcome by using considerable mercury and recovering the amalgam after each operation.

Should an amalgamated copper plate be placed in a vat with the amalgam dry on it, the chance of its being scraped off by abrasion or grinding of the ore is possible, especially if the mercury be small in amount and the pulp circulating strongly. The electrical current, together with the adhesion of the mercury to the copper plate, keeps the gold in contact with the plate. If too much mercury be used, it will be forced into a free state, but if enough is used to keep the amalgam plastic and no more, it will not be rubbed off. However, to avoid such chances as these mercury in large quantities is poured into the vat to act as a cathode.

The action of the liquid in circulating may give this liquid mercury a movement, but as it is denser than the liquid it only partially assumes motion. Still it is sufficient, where horizontal circular motion is employed, to move the mercury, so as at times to uncover the bottom of the vat in places. Just at this point mercury cathodes fail, for the molecule in the act of depositing its atom of gold may hit a bare spot and the next moment be lifted away. To overcome this difficulty a copper amalgamated plate can be used in connection with the mercury, then if the liquid mercury is disturbed the atom of gold may be deposited on the copper plate. Other cathodes besides mercury and lead have been tried, such as carbon.

The vat of the Pelatan-Clerici process contains 60 square feet of copper cathode, on which is poured 500 pounds of mercury. The mercury should amalgamate the coarse gold, and also the deposited gold from the electrolyte. The current from the anode seems to focus, like the heat-rays from a lens, upon that portion of cathode directly under the pendent stirrer-shaft.

In this case the copper is penetrated, and, while not a decided objection, requires more time to recover the gold, and also demands renewal of the copper plates from time to time.

It has been ascertained from experiment that 12

square feet of cathode surface is sufficient for the deposition of 1 gram of gold in one hour.

**Lead Cathodes.**—The cathode of lead that is used in the Siemens-Halske process is of thin sheet metal, and is as light and thin as can be handled. It is in fact lead-foil stretched on iron wires, fastened to a wooden frame to keep it taut and offer an even, smooth surface for the deposit of gold. The advantages of this lead-foil are cheapness, light weight, hence cheap handling, and the recovery of gold, for in the latter case the lead and gold are smelted together, and the gold is recovered by cupellation.

Siemens and Halske have made two great improvements over the old leaching process in that they have reduced the cost and obtained purer bullion.



## CHAPTER XV.

### SIEMENS-HALSKE AND PELATAN-CLERICI PROCESSES.

#### THE SIEMENS-HALSKE PROCESS.

THE distinguishing features of this process are the dilute solutions used for gold extraction, and the precipitation of the gold from these solutions. The strong solution is 0.1 per cent and the weak solution 0.01 per cent. In the treatment of slimes 0.008 per cent solutions are used at the Crown Reef South Africa works as the strongest, and zinc would not precipitate gold from such solutions satisfactorily.

The plant and operations for this process are the same as for the regular cyanide process until the precipitation part of the operation is reached. The process has been used with success at a number of plants in South Africa. On account of the small quantity of gold in solution, constant diffusion of the solution is required, and this is accomplished by having a small but steady flow of the liquor through the precipitation-boxes. The electrodes must have a large

surface, since their action is more efficient when this is the case than are small surfaces with increased current.

The advantage claimed for this process is that a weak solution, say .03 per cent cyanide, will dissolve gold as effectively as a solution containing 0.3 per cent, thus saving in cyanide, but this will require a longer time and zinc precipitation would not be as effective as where electrical precipitation is practiced. Again, precipitation acts independently of the quantity of cyanide or caustic alkali in the solution, the limit of dilute cyanide solutions being such that they will dissolve gold.

Another feature is that precipitation will be as effective with acid, alkali, or neutral solutions, and no complications arise from the formation of lime, alumina, or iron hydrates.

With copper in the ore the extraction of gold will be the same, but on account of the weak solutions the loss of cyanide will be less.

**The Precipitation-boxes.**—There are four precipitation-boxes, constructed of wood, each 18 feet long, 7 feet wide, and 3 feet deep. Each box contains eighty-nine iron-plate anodes, 7 feet by 3 feet by  $\frac{1}{8}$  inch thick, encased in canvas to retain the Prussian and Trumbull blues produced; and eighty-eight cathodes of lead-foil, stretched on iron wires fixed on a wooden frame. Each frame contains three strips 3 feet by

2 feet, so that, counting the double surface of each lead sheet and the number of boxes, there are 12,000 square feet of cathode surface and 14,000 square feet of anode surface. Copper wires are fixed along the top of the sides of the boxes to convey the current from the dynamos to the electrodes.

In order to assist the circulation of the solutions, some of the iron sheets extend down to the bottom of the box, while the next are raised an inch or two above, thus forming a series of compartments similar to those shown in the zinc-boxes, where the solution passed in at the bottom of one box and over the top into the next.

The boxes are opened once a month for a general clean-up. The frames carrying the lead cathodes are removed one at a time, and the lead sheet, which contains from 2 to 12 per cent of gold, taken from the frame. A fresh sheet of lead is placed on the frame and it is returned to the box, the whole operation requiring but a few minutes, during which time the process of precipitation continues on the lead sheets remaining in the box.

The details of the process, as far as lixiviation is concerned, do not differ much from regular cyanide plants, except as stated, in using much weaker solutions.

In speaking of this electrolytic cyanide process Mr. A. von Gernet stated before the South African

Metallurgical Society that the output from them was larger in profanity than in gold; since then changes in conditions have increased the output of profanity against South African gold more than fool electrolytic cyanide processes.

#### THE PELATAN-CLERICI PROCESS.

**The Tank.**—The bath is a common wooden tank 9 feet wide and 4 feet high of from  $2\frac{1}{2}$  to 3 tons capacity. A copper plate lies in the bottom of it and is connected with the staves by a rim so as to prevent any leakage of quicksilver. The copper plate is amalgamated and covered with a thin layer of quicksilver, and is connected with the negative wire of a dynamo.

The pulp in the tank is kept in motion by a four-armed agitator suspended by two collars and driven at the top by bevel-gearing. Several brackets break the vortex produced by the agitator, pushing the pulp to the centre so that the pulp has an equal density in all the parts of the tank. The anode plates are suspended underneath the arms of the agitator and are connected with the shaft by a strong spider; the surfaces of contact are very large and there is practically no resistance in the connection. The anode arms are from 3 to 6 inches above the quicksilver level, accord-

ing to the kind of treatment followed and which depends upon the character of the ore. The shaft of the agitator carrying the current to the anode is connected with the positive pole of a dynamo by means of a collar slightly pressed against the shaft by a spring.

**Working of a Pelatan-Clerici Tank.**—Treatment by the Pelatan-Clerici process consists of a single operation. The tank is filled with crushed ore, then a dilute solution of cyanide of potassium, common salt, and, if required, some other accessory chemical is added, the proportion of each one being calculated according to the quality of the ore treated. The agitator is next set in motion so as to mix the ore with the solution and to make a liquid sludge through which the current is allowed to pass freely.

When the ore has remained sufficiently long in the vat under the combined influence of the agitator and current, so that the gold and silver have been deposited as amalgam, the solution and the tailings are removed through an opening at the bottom. The tank is then ready to receive another charge of ore. Where water is scarce the pulp is allowed to settle in a tank below the vat, the liquid drained off and pumped up into the treatment-tanks. Even if the liquid is not clear and but contains very fine material in suspension that does not detract from its further



use, because the process works even better with very fine slimes than with coarser stuff.

The time required for working out a charge varies from eight to twelve hours.

The cost of labor is small, as nearly all the hand work is reduced to opening and shutting a few valves; but a very close supervision is necessary. There are no parts which are specially liable to rapid wear and tear.

**Dissolution.**—The tank is divided into two parts by the anode plates. In the lower part the precipitation takes place when the dissolution is completed in the upper part. This division is not very correct; according to the theory that all the liquid between the anode and the cathode is electrolyzed, it is not possible for dissolution to take place in the lower part; but according to the theory that only the liquid in contact with the anode and cathode is decomposed, it is possible to have some dissolution in the lower part.

The current decomposes the potassium cyanide first into free cyanhydric acid and metallic potassium; the free cyanhydric acid is diffused as *statu nascendi* in the bath, but it cannot reunite with gold and silver in the lower part of the bath, because the current passing through does not allow the chemical combination, so that both gold and silver combine with free cyanhydric

acid only in the upper part of the tank. At the same time a small amount of both gold and silver is dissolved in the cyanide of potassium. Free oxygen in the bath, liberated by the current, helps the dissolution of gold and silver in the cyanide of potassium, as is proven by the Kendall process which uses peroxide of sodium for the purpose.

But, notwithstanding this, the largest amount of gold and silver is dissolved by the free cyanhydric acid, for the latter, especially at *statu nascendi*, is a stronger solvent than the potassium cyanide, as is proven by the fact that in the Pelatan-Clerici process the dissolution of all the gold takes place in four or five hours, while it never takes less than twenty-four hours in the common cyanide process.

The current after a short time begins to decompose the double cyanide of potassium and gold and the cyanides of gold, silver, and potassium, and when the cyanhydric acid produced is ready to dissolve more gold and silver, the gold begins to be deposited.

Gold and silver which are sometimes in a coarse condition, would require a long time to be dissolved, but the Pelatan-Clerici process acting in such cases as a common amalgamation-pan, by holding the pulp suspended in the liquid solution permits the coarse grains of gold and silver to gradually sink to the bottom of the vat, where they are amalgamated.

Advantage is taken of the cyanhydric acid liberated at the anode, so that the solving of the gold continues and aids in keeping the electrolyte constant for a certain time.

**Precipitation.**—The Pelatan-Clerici process is sometimes misunderstood, because it is compared with electroplating and some other electrical processes. It is true that there is electrolytic precipitation, as in the other processes and electroplating, but the precipitation is obtained in such a different way that a simile is not possible.

In the Siemens-Halske process diffusion is necessary; in this process and in electroplating the current density must be calculated so that the deposit is regular and neither crystalline nor pulverulent. The exhaustion of the salts near the cathode is also a cause of imperfect deposits in electroplating.

The nature of the deposit does not interfere in the Pelatan-Clerici process, because the variations of density and intensity of the current do not change the physical conditions of the molecules, but the actions of the molecular force. The setting free of hydrogen, notwithstanding the increased number of amperes required, is a great advantage, the hydrogen keeping the quicksilver clean.

The conditions of precipitation do not require soluble anodes of deposited metal, concentrated solu-

tions, nor yet an electrolyte of constant composition, and it is more than likely that some of the impurities in the liquid assist or retard the action of the current, but the effects of these compounds may be prevented.

With purely chemical reactions it makes considerable difference to the ordinary cyanide process whether the solution is strong or weak; and as far as the deposition of metal is concerned it is possible to use so weak a solution of cyanide that the finest zinc shavings will not deposit the gold, while an electrical current of determined intensity and density readily deposits it.

It is frequently stated to be impossible to exhaust the solution by electrolytic deposition, and that is true; but when it is possible, as in the Pelatan-Clerici process, to have the solutions carry fractions of grams after eleven hours' run (usually less than  $\frac{1}{4}$  gram per ton of ore) one may say the solutions are practically exhausted.

The chief factors for perfect deposition are strength of the counter E.M.F. to be overcome, the chemical equivalent of the substances to be separated, the conduction-resistance of the electrolyte, and the selective electrolytic action of the current.

The action at the anode regulates the deposition of the metals, as stated by Becquerel's law, and the salts are decomposed in the order stated by Tom-

masi's law; that is to say, the order of decomposition of the salt is regulated by the amount of E.M.F. required. To this last law may be added that the order of the decomposition of salts is regulated by the degree of weakness of the solution.

Thus the salt which opposes the less counter E.M.F. is decomposed first, and the salt which is next in order of amount of E.M.F. required begins to be decomposed when the solution of the first salt has reached a determined degree of weakness, etc.; and the same for the following salts.

In this way there may be several salts decomposed at the same time, but the degree of exhaustion of the solution of each salt will be indirectly proportional to the required E.M.F.

In a fixed time a given current will deposit a certain quantity of metal, but in a dilute solution the current does not find sufficient metal present to decompose it, therefore decomposes water.

This latter decomposition raises the temperature, and in so doing assists in solving gold, in keeping warm the quicksilver, increasing its absorption capacity without increasing the temperature, sufficiently to cause either extra appreciable resistance to the current or an appreciable destruction of cyanide.

The highest specific resistance, which robs the electrolytical deposition processes of their cheapness,



scientifically taken advantage of as in the Pelatan-Clerici process, aids in simplifying the process.

The theory of Prof. Christy is that in the electrolytical precipitation the  $\text{AuCN}_2$  goes to the anode, and the metallic potassium to the cathode, or under ordinary conditions gold is deposited upon an iron anode. If the salt of gold and potassium is decomposed, the gold must be found on the cathode; it is much more probable that the  $\text{KCN}_2$  goes to the anode and gold to the cathode, because gold is less positive than potassium.

Electrical precipitation, especially when the theory is not well understood and imperfectly applied, is not perfect, but electrical precipitation is embodied in the process with evident success.

In the cut shown of the Pelatan-Clerici vat the anode is seen to be a four-bladed propeller fastened to a shaft depending from a gear-wheel. In the anodes are seen a number of wooden teeth which extend to within  $1\frac{1}{2}$  inches of the cathode. These teeth are for the purpose of keeping the sands from settling on the mercury. In one instance on record they were placed so low that the amalgam and mercury had to be collected in the creek bed, scarcely any remaining in the vat. The current is seen to enter the shaft by a wire, and leave the vat by a wire attached to the cathode.

In practice there are two of these vats, one slightly above the other, the ore having a preliminary treatment in the first vat, and being cyanided in the

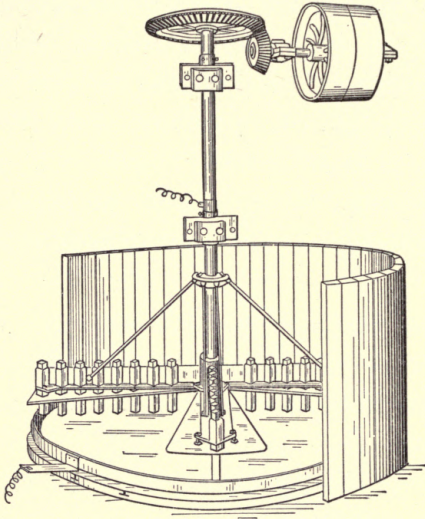

Fig. 12

second. The method of moving the stirrer in the vat is so plainly shown that it needs no further explanation.

## CHAPTER XVI.

### CYANIDING SLIMES.

DURING the operation of crushing ore a certain quantity of powdered material is produced that remains suspended in water, and can only be settled in standing water.

This fine suspended matter, or colloidal hydrate, termed slime, increases in quantity according to the fineness with which an ore is crushed. Some talcy and soft ores slime more readily than hard quartz ores, while other kinds of ore float when their particles are not extremely fine, owing to minute air bubbles furnishing the buoyancy. It may be presumed therefore that slime is not altogether a matter of extreme fineness, since aeration in the process of crushing greatly increases the floating power of particles. While the cyanide process is efficient in leaching fine free gold from sands, nevertheless mixtures of sand and slime furnish very unsatisfactory results, owing to slow percolation and the quantity of gold retained in the tailing. When the rate of percolation is less than one inch per hour, it becomes

economical to separate sand from slime and treat each separately, thereby increasing the percentage of gold recovery and decreasing the cost of extraction.

In addition to slime preventing percolation, it retains its own weight in moisture, and if the moisture be gold-bearing cyanide solution, there is a retention of gold. In the Transvaal, where decantation was practiced prior to the introduction of filter pressing, forty per cent of the gold in solution was retained in the slime, and could not be recovered.

The first step in the recovery of gold and silver from slime, is to separate the sand and slime. For this purpose the Butter's distributor is generally used in connection with the Blaisdell improvements, particularly at large mills. The original distributor was supported by a swinging crane, and had to be moved from tank to tank by manual labor; the improved Blaisdell distributor, shown in Fig. 13, is moved by machinery. Where sand-collecting vats are used the value of the Blaisdell movable bridge is not so apparent as when the sands are leached in the tanks wherein they are collected. When using the distributor the pulp is delivered to the hopper of the distributor at the center of the bridge and flows through the radial projecting pipes that terminate in nozzles which discharge in a direction opposite to that in which the machine revolves. (See p. 65.) Owing to the varying lengths of the distributing pipes the sand



is evenly deposited in the vat, while the water and slime flow through the discharge gate in the side of the vat, or through a perforated pipe gate in the center of the vat.

Until recently the vats were filled with water, before the distributor was set in motion, and the overflow was caught in a launder that encircled the vat. This

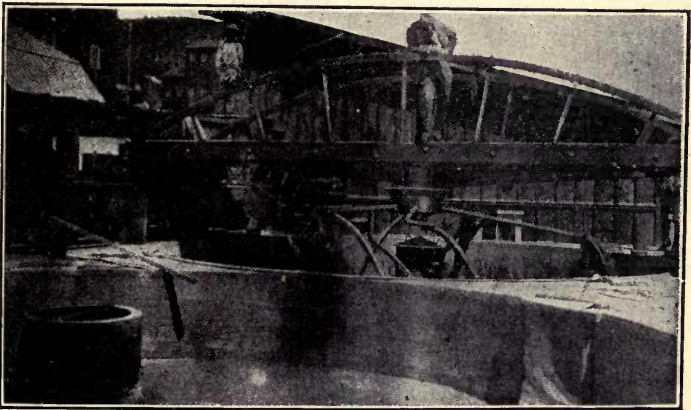

**Fig. 13.—Blaisdell Class W Wet Pulp Distributor.**

EL ORO MINING AND RAILWAY CO., LTD., EL ORO, MEXICO.

practice is objectionable, owing to the increased quantity of water that must be separated from the slime. The slime discharge gates, as shown in the side of vat, are fitted with canvas curtains fastened to the bottom of the gates on rollers, and as the sand accumulates, they are unrolled upwards to cover the gates sufficiently



to retain the sand while permitting the slime and water to flow out over them.

Butter's wet pulp distributor is made to revolve by the reaction induced by the pulp as it is discharged from the nozzles; in other words, it is a reaction wheel.

Another system equally as effective in separating slimes from sands consists in running the pulp from the crushers to a log washer, where the sands settle and the slimes held in suspension float away. The clean sands are worked out of the washer by the blades and can be run directly to the vat in which they are to be cyanided without extra handling, while the slimes float to the tanks where they are dewatered. As a usual thing, too much water is associated with slime for economical work, for which reason the surplus must be separated before cyaniding. This operation is called dewatering, and may be accomplished by allowing the slime to settle in dams or in large cone-shaped tanks; by the use of filter presses or pressure filters, or by the Nichols apparatus. To avoid the use of excessive quantities of solution slimes are diluted with from  $2\frac{1}{2}$  to  $3\frac{1}{2}$  times their own bulk, if less than this the slimes are difficult to treat, owing to their being too stiff. (See p. 131.)

**Slime Agitators.**—Since the introduction of filter-presses and vacuum filters the time required to treat a slime charge has been greatly reduced by slime-agi-

tating machinery. In some cases it has been found profitable to slime all ore in tube mills; in other cases, it has been found advantageous to stamp the ore in cyanide solutions, thus doing away with excessive quantities of water; in every case, however, it is probably better to use some form of agitator to hasten the solution of the gold and silver.

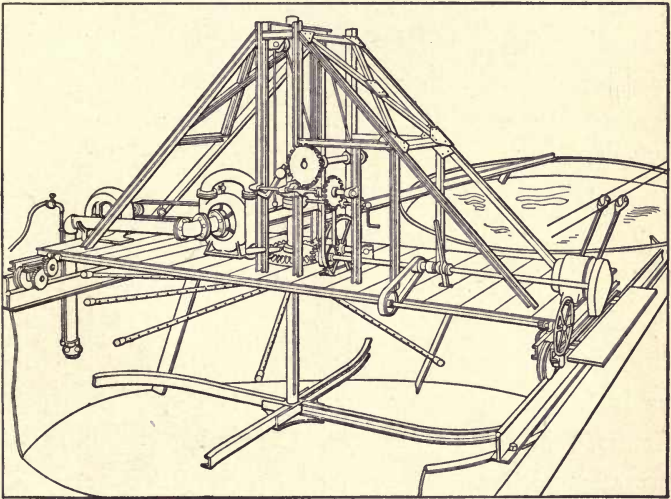

Fig. 14

The Blaisdell agitator is supported on a travelling bridge, as shown in Fig. 14. A central shaft, having four radiating arms is so arranged as to be raised, lowered, and revolved by gearing. In the agitator illustrated the pulp is whirled about the vat by the arms and as it

meets the inclined planks arranged near the periphery it receives an upward movement.

A centrifugal pump is mounted with its motor on the bridge, and this lifts the pulp through its tail pipe and discharges it back in the tank through a series of radiating pipes. In another kind of Blaisdell agitator no pump is used, but a compressor forces air through the hollow main-shaft and through holes in the stirrer arms. The air agitates and aerates the solution in the latter contrivance, while the arms agitate and the pump and spray pipes aerate the slime pulp in the former agitator. Either machine, and indeed the pump with the spray pipes, is an effective agitator and aerator. The Hendryx agitator is liked through the western United States. This machine, shown in Fig. 15, consists of a cylindrical tank with a conical bottom. In the center is a circular well suitably braced and supported, which extends to the top and nearly to the bottom of the tank. Centered in the well is a shaft carrying a number of propeller blades. These propeller blades are rotated by a driving pulley near the top of the shaft, and as they revolve, lift the pulp from the bottom of the vat up through the well to a circular apron. The apron slopes gradually toward the circumference of the vat, and is supplied with suitable orifices to permit the pulp to flow back to the vat as it is spread over its surface by the propeller blades, thus aerating the solution.

Slime Decantation Process.\*—Mr. J. R. Williams introduced the decantation system of treating slimes

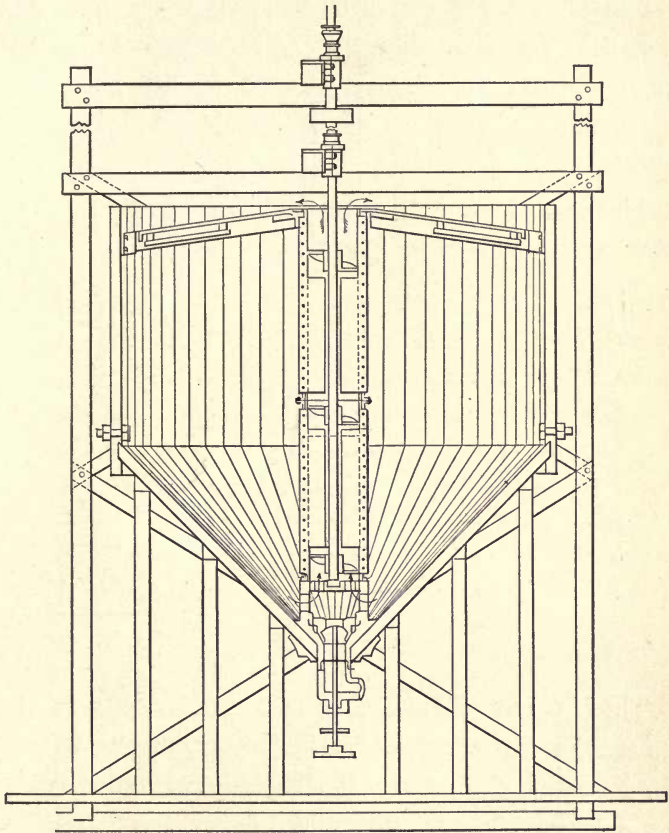

Fig. 15

in 1896. In his process the slimes were taken from a settling dam and agitated with cyanide solutions.

\* See p. 129.

Potassium cyanide will not readily dissolve with slimes unless they are greatly diluted with water, for which reason the cyanide should be in solution and the solution used for slime diluting. After agitation with cyanide solution the slime is allowed to settle, and the liquor above it siphoned off and conducted to the gold solution tank.

The cost of decantation in South Africa under favorable conditions was as follows:

Filling and discharging vats .....	\$0.21266
Cost of potassium cyanide .....	.10594
Cost of zinc for precipitation .....	.01840
Cost of lime for settling, etc. ....	.07074
Supplies .....	.06628
Power .....	.04312
Maintenance .....	.10146
Water .....	.01554
Assaying .....	.03404
	\$0.66818

The high cost of lime, seven cents per ton, was due to its use for correcting acidity in the ore, and to its use for hastening the settling of slime so decantation could be quickened. Some slimes settle very slowly and to hasten the process, lime, caustic-alkalies or alum is added to the solution. Mr. E. W. Hamilton\* states

---

\* Mining and Scientific Press.



that in the case of the Comstock slime "lime added to the pulp causes it to gelatinize and the slime loses to a large extent its power to gravitate." In such cases decantation cannot be practiced, but recourse may be had to one of the various filter-press processes. (See p. 131.)

**Filter-press Process.**—The filter-press was introduced as an adjunct to treating slimes in 1898 by the Lake View Mining Company in Kalgoorlie, Western Australia.

Dr. Diehl claims to have originated the filter-press method in 1896, while Mr. Sutherland is credited with its successful introduction on a commercial scale in 1898. The filter-press process was successful from the start on the peculiar Kalgoorlie telluride ore, and has since been modified and introduced in most places where cyaniding is practiced.

The first filter-presses installed were Johnson's, these, however, were soon replaced by Dehne's, a German press. The accompanying illustrations are of the Sweetland press, manufactured in Los Angeles, California. A side elevation, Fig. 16, of this press, with a section removed, shows that it is made up of a series of cast-iron frames, *a* and *b*, arranged alternately side by side and supported by side arms *c*. The side arms terminate with threads that work through the heads *d* in such a way as to hold the frames like a vise. Each frame is

machine planed on both sides, and on one side a piece of rubber is cemented, so that when placed in position and pressure brought to bear on them, they form water-tight joints, with a hopper-shaped tank *e* at the bottom.

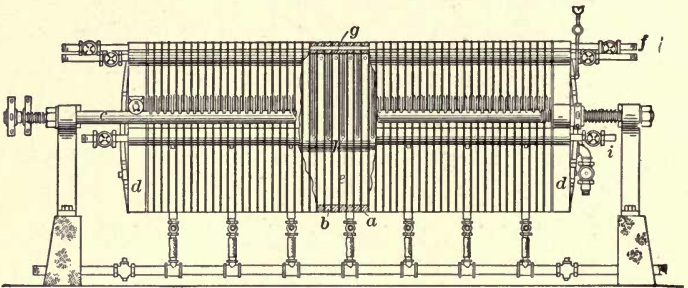

Fig. 16

The slime pulp comes through pipe *f*, and being under pressure, enters the space *g* between two filter-mats, then finds an exit through pipe *h* to the conduit *i*, and so to the gold solution tank. The filter-mats in frame *b* are composed of two layers of cocoa matting covered with an envelop of 15-ounce duck, Fig. 17. When slimes are being forced by air pressure against this filter, the liquor passes through the canvas and finds an outlet through pipe *a* to the conduit *b* made by the holes in the filter frames. There is a pet cock *c* in connection with the pipe *a* in each filter-mat, for the purpose of detecting any break that may occur in the filter. The slime solution comes through hole *d*, the air through hole *e*, the wash water through hole *f*; while the hole *g*

is for connection with the interior of the next filter-mat in the series which has an arrangement similar to *a*, *b*, and *c*.

Chambers are formed by the filter frame, shown in Fig. 18, being placed between two mat frames. If

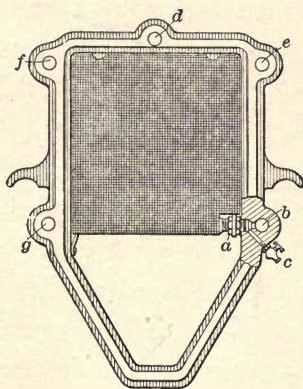

Fig. 17

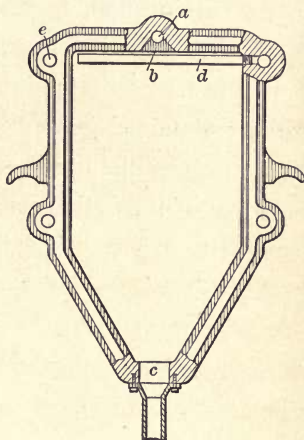

Fig. 18

compressed air is used to force the liquid from the slime through the filter-mat a montejus or pressure tank is required, and probably such a tank would be advisable where pressure pumps were employed. When the press is in use the slime pulp enters through the conduit *a* and inlets *b* to the chambers, where the air pressure in the montejus forces the liquid from the pulp through the filter-mat. The air pressure is varied between 30 and 60 lbs. per sq. in. to comport with the kind of slime under treatment, and the thickness of the cake.

As the filtrate passes through the mat the solid slime accumulates on the outside; when, however, a cake has formed 2 in. in thickness, the slime pulp supply is turned off, and that remaining in the press is discharged through drain pipe *c*, to the slime pulp sump. To prevent the cake on the filter-mat falling off a 10-in. vacuum is set up on the interior of the filter, or air pressure is maintained in the press.

To displace the gold solution in the filter cake, a weak cyanide solution is run into the press, forced through the filter and out in the same manner as the filtrate. To displace the weak cyanide solution in the filter cake wash water is used, after the weak solution has been drained from the press.

The last displacement having occurred the wash water is turned off, and compressed air or water admitted to the interior of the filter to loosen the cake and cause it to fall to the hopper as mud. While the sludge is being discharged through drain pipe *c*, water enters the interior of the filter from *e*, and at the same time water sprayed from pipe *d* washes the exterior of the filter. If during filtering operations the filtrate should become muddy, it indicates that a filter has broken. By means of the try-cocks the broken filter can be located, removed, and replaced in 15 minutes. The time consumed in a cycle of operations, in actual practice at Kalgoorlie, is as follows.



Filling press from receiver .....	15	minutes
Washing cakes in press. ....	19	“
Discharging and closing press. ....	16	“
Total .....	<u>50</u>	“

Previous to sending the slime to the press it is agitated with cyanide solution, and pumped to the montejus. At the Lake View Mine in Kalgoorlie, the slime is washed from the sands by a distributor, and is conducted to V-shaped boxes, which also act as classifiers and retain any sand that escaped from the vats. The slime leaving the V boxes flows to settling-tanks from which the excess of muddy water is drawn off and pumped to one of two filter-presses. The sediment in the water is held by the filters, and when it has accumulated as a cake, it is treated the same as the other slime cakes. If there is a scarcity of water, that passing the dewatering presses can be returned to the crushers. Heavy slime that accumulates in the settling-tank is drawn off through valves attached to the bottom, into a montejus, from which it is forced by compressed air into a third filter-press. At the Lake View mine the slime is leached with cyanide solutions after it has formed on the filter-mat, but this practice is not satisfactorily performed unless the free gold is very fine. At this mine all ore is slimed owing to its talcy nature and the small quantity of sand made in comparison to the slime.



The advantages of the filter-press process, when compared with the disadvantages of the decantation process, are about as follows:

(1) Saving in time to the extent that a five-ton filter-press will treat as much as a 1000-ton vat in the same time.

(2) The initial cost of the filter-press plant is less than a slime-decantation plant.

(3) There is an economy in space, and the filter-press is portable.

(4) There is a saving in labor, chemicals, and water brought about by the use of machinery, compactness of the plant, and the lessened quantity of cyanide solution needed. In decantation from 6 to 8 tons of water and solution are required, per ton of slime, or about six times that needed in filter pressing.

(5) Slime pumps, settling-dams, and filter-beds, which not only occupy space but require considerable attention, are discarded when filter-presses are installed. Filter-beds are required in decantation to clarify the gold solutions before they are sent to the zinc boxes, and even then a certain amount of suspended matter will go into the zinc boxes and increase the bulk of gold slime.

(6) The recovery of gold is at least fifty per cent better with filter-presses.

The cost of this process at Lake View mines was as follows:

	s.	d.	\$
Labor .....	I	4.337	0.33674
Trucking .....		7.491	0.14982
Engine-driving .....		1.978	0.03956
Compressed air .....		3.773	0.07546
Smelting .....		0.559	0.01118
Repairs .....		4.094	0.08188
KCN .....	I	6.497	0.37994
Lime .....		2.041	0.04082
Zinc .....		0.538	0.01176
Fuel .....		5.881	0.11762
Filter cloth .....		0.861	0.01722
Turning zinc .....		0.223	0.00446
Sundries .....		1.697	0.03394
Condensed water .....		3.217	0.06434
Removal of slimes from settling dam to press ..		7.976	0.15952
Salt water .....		1.512	0.03024
Assays .....		2.301	0.04602
		<hr/>	<hr/>
	6s.	7.347d.	1.64694

This slime carried about \$8.10 per ton in gold, and the high price of \$1.647 could readily be paid for treatment. The cost of materials, fuel, and supplies is high in comparison with their cost in the United States. A filter-press plant of this description capable of treating 150 tons of slime per day would cost between \$15,000 and \$25,000, and require three 6-ton presses.

**The Vacuum Filter.**—Mr. George Moore's introduction of the movable vacuum filter in 1903 marked an epoch in the treatment of gold slimes by cyanide of potassium. Not only did this process decrease the cost, but it stimulated inventors to work out improve-

ments applicable to the process. Moore's process requires a series of suitable filter-mats, arranged on frames, to be joined and submerged in slime pulp whose liquor contains the gold and silver in solution. To draw the gold solution from the slime pulp through the filter and to the gold solution tank, a series of pipes are connected with the interior of the filter and with a vacuum pump.

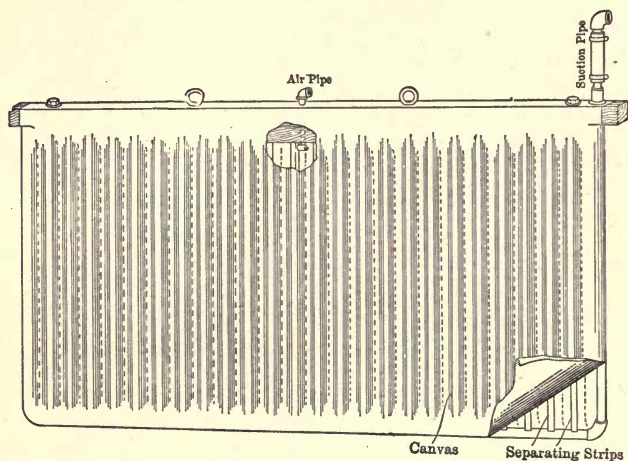

Fig. 19

The filter, shown in Fig. 19, consists of an iron pipe frame terminating on one side in a projecting suction-pipe. The lower pipe of the frame is cut to form a trough, and in this trough at regular distances upright wooden strips are placed as stiffeners. Over the strips cocoa matting is laid, and the whole frame covered with

15-ounce duck. The canvas is stitched between the stiffeners. When several such frames are bolted together they form a *basket* that permits the quick withdrawal of frames from the solutions. In large plants a number of small frames are joined in one basket, or a small number of large frames; for example, at the Liberty Bell mine in Colorado there are five baskets each containing 66 frames; while at Virginia City,

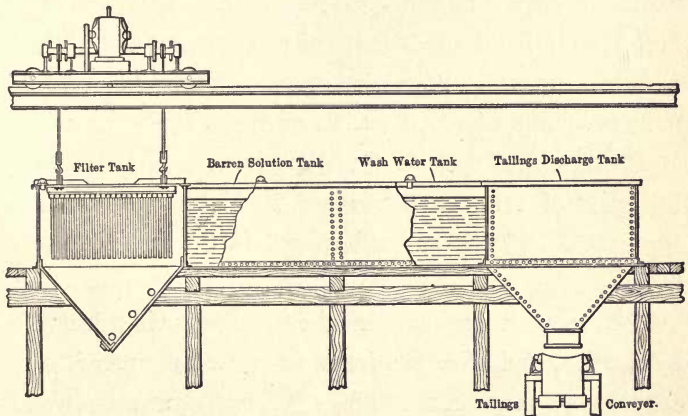

Fig. 20

Nevada, and Millers, Nevada, the baskets are made up of 4 frames, each about 10 by 5 feet.

Vacuum filters are of two types, stationary and movable, the latter arrangement is shown in Fig. 20, and is known as Moore's Slime Process. In the illustration a basket is suspended from a movable electric crane, and submerged in a filter-tank. The slime pulp is usually

mixed with cyanide solution previous to its entering the filter-tank, and to prevent its settling, agitation is produced by jets of compressed air flowing from pipes. As the pulp solution is decreased in quantity by drawing the liquor through the filters it is replenished by additional slime pulp, and any overflow coming from the leaching-vat is returned to the slime-vat. The pulp should contain as much solid matter as is consistent with proper work, or have a specific gravity between 1.3 and 1.4. Since 32 cu. ft. of water is equal to 1 ton, a slime diluted with  $3\frac{1}{2}$  times its bulk of water weighing 1 ton will have a volume of 2.778 cu. ft. and a specific gravity of about 1.38. As soon as the slime has accumulated to a thickness of 1 in. on the frame, the basket is removed from the filter-tank and submerged in the wash-solution tank.

The vacuum is kept on the frame during transfer by a valve, and after the frame is again submerged, it is coupled to the vacuum pump which now draws the weak solution through the filter cake, and displaces the gold solution. When this is accomplished the vacuum valve is turned, the vacuum still being maintained on the filter, and the basket is lifted, transferred to and submerged in the wash-water tank. This tank contains clear water, and washes the cake and filter free from the weak solution. The basket is again raised after the washing operation and transferred to the discharge



tank. The vacuum is now released for the first time since the operation commenced, and water under slight pressure is admitted through the vacuum pipe to the interior of the filter. This water softens and pushes the slime cake from the canvas and at the same time washes the interior of the filter, while another arrangement washes the filter canvas on the outside, prior to its being returned to the slime-pulp vat. When the filter has been thoroughly cleaned the slime sludge is washed from the discharge tank-hopper to the belt conveyor and carried to the waste dump.

In the decantation process the total time required to leach and wash is 15 days, while the time required to leach, wash, and filter a similar bulk of slime by the vacuum process would probably not exceed 1 day. The time required for forming a cake will vary from 40 to 120 minutes; displacing the gold solution with weak solution, 25 minutes; washing the cake, discharging, washing and returning the filter to slime tank, 15 minutes.

**The Stationary Vacuum Filter.**—Butter's stationary method of slime filtration is so similar to the Moore stationary-vacuum process that both use Fig. 21 to illustrate the operations. After the pulp is dewatered, it is agitated in tank *A*, with cyanide solution, and is known as stock pulp. The filter-tank *E* is connected with *A* by suitable valves, and the pipes *V* and *U* also by suitable valves with the centrifugal pump *Q*. The

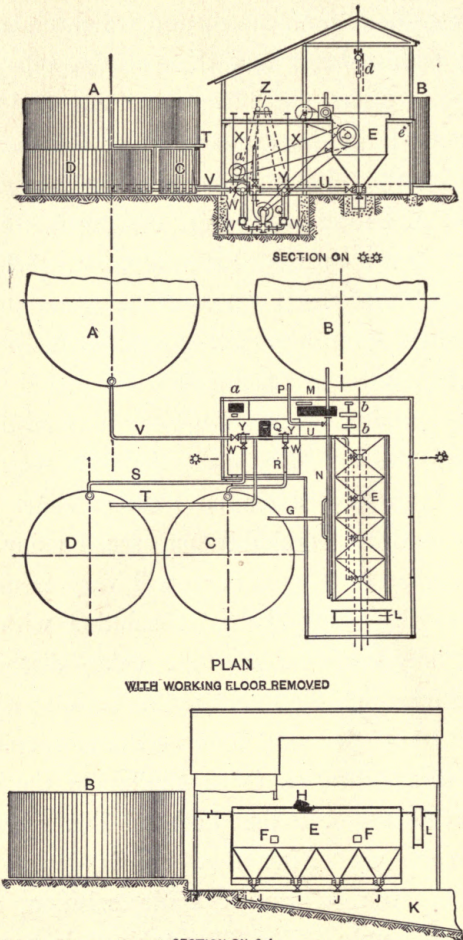

Fig. 21

filter frames rest on shelves in tank *E*, and after the tank is filled with stock pulp, the vacuum pump *M* draws the filtrate through pipe *N* and discharges it in gold-solution tank *B*. The stock pulp is drawn from the filter-tank *E* and returned to tank *A* as soon as a slime cake of suitable thickness has formed, and then the filter-tank is filled with wash cyanide solution from tank *D*. As soon as the wash solution has replaced the gold solution in the slime cake, that which remains is withdrawn from the filter-tank and pumped to tank *D*, after which operation clean wash water is run into the filter-tank through pipe *R*, valve *Y* and pipe *U*.

The wash water is first used to displace the wash solution in the slime cake; next a part of it is returned through pipe *G* to tank *C*, and the remainder is used to collect and flush the sludge from the hopper in the filter-tank. Water or air is next forced through the filters to dislodge the slime cake, after which the filters are washed down on the outside by sprays from pipe *H* and a hose. The valves *J* are opened, and the sludge in the hoppers flushed into sewer *K* and to waste. Where lime is required to neutralize acid ore, the canvas becomes coated in time, and to remove the lime an acid bath in tank *L* is used. To clean the filters they are raised from tank *E* by the pulley *d*, transferred to *L*, and after cleaning are returned in the same manner.

The time required for a cycle of operations at the Virginia City plant is as follows:\*

Filling and making $\frac{3}{4}$ -in. cake .....	45 m.
Changing solutions .....	25 m.
Filtering wash solution . . . . .	1 hr. 15 m.
Replacing solutions, washing, and discharging sludge .....	35 m.
<hr/>	
Total time of operation.....	3 hr. 0 m.

The cost of the operation is given as follows:

Labor per ton of slime .....	\$0.06
Power per ton.....	.03
Repairs per ton .....	.002
Acid treatment per ton .....	.015
<hr/>	
Total cost per ton .....	\$0.107

Tailing from the vacuum process is said to contain less than 5 cents per ton in soluble gold and silver, while the operating cost compared with the decantation process and with filter-press work is materially reduced.

The time required to draw off and pump the solutions in the Butter's process exceeds the time required for transferring the filter frames from tank to tank in the Moore process, however, the first cost of plant is materially reduced in the stationary process.

---

\* Hamilton, E. M., Mining and Scientific Press, June, 1907.



**The Blaisdell Pressure Filter.**—The operation of the Blaisdell filter, consists in forcing the liquor from slime pulp through filter leaves, thereby depositing a slime cake on the outside of the filter. The filter consists

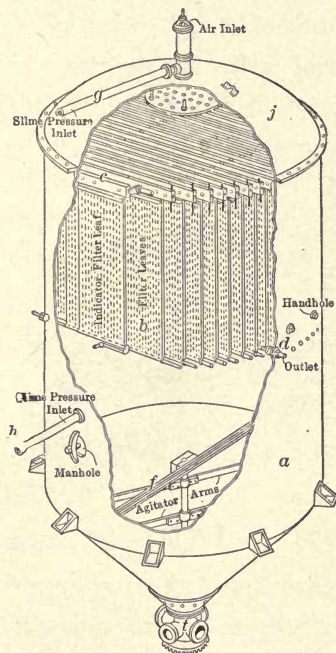

Fig. 22

of a pressure tank or montejus *a*, Fig. 22; filter leaves *b*, resting on brackets *c*; filtrate pipes *d*, passing through snell; agitator arms *f*; and slime inlets *g* and *h* which, with the sludge outlet *i*, have quick-acting gate-valves



attached when the cylinder is set up. The cover *j* is bolted to the cylinder so that it may be removed whenever the leaves are to be repaired. Each filter leaf, the details of which are shown in Fig. 23, consists of a series of grooved separating strips, standing upright on a pipe, in which a number of  $\frac{3}{16}$ -inch holes are drilled in line. Both the pipes and strips are covered with canvas that is carefully stitched to guard against collapse or tears.

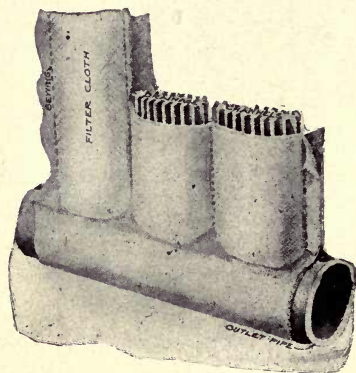

Fig. 23

The peculiar construction and arrangement of the strips is to prevent the collapse of the canvas and furnish a passage for the filtrate to the outlet pipe.

The process of extracting the gold-silver cyanide solution from the slime pulp is as follows:

The slime is dewatered, and agitated with cyanide solution in agitation vats until all gold is in solution. It is then drained from the agitation-vat, and flows by

gravity to a sump-tank. A pressure pump raises the pulp from the sump-tank to the pressure-filter tank, and maintains a pressure of from 25 to 50 lbs. per sq. in. on the liquid in the pressure cylinder, until an alarm bell indicates that the slime cake on the filter has attained the desired thickness—about  $1\frac{1}{2}$  inches. The liquor which passes through the filter is conducted to a gold-solution tank by an arrangement of suitable pipes and valves. So soon as the slime cake has been formed the pressure pump is stopped, and a vacuum pump is connected with the filter-discharge pipe in order to hold the cake on the filter while the slime pulp in the pressure cylinder is being discharged to the slime pulp sump. The pressure cylinder is then filled with weak cyanide solution by a pressure pump, the vacuum removed, and the gold solution in the cake displaced. The weak solution is drawn from the pressure cylinder and pumped to the cyanide wash-tank, the vacuum pump in the meantime holding the cake on the filter leaves. Following this, wash water displaces the weak solution, and finally the cake is washed from the filter and out at the bottom of the tank as sludge. With an average slime a cycle of operations is said to require about two hours.

To assist in forming a cake of even thickness on the filters, the slime pulp is circulated among the leaves by allowing a portion to flow from the top of the pressure cylinder through a regulating pipe and back to the slime-

pulp tank. It will be noticed that there are two slime-pulp inlets *h* and *g* in Fig. 22. These can be connected at will with the pressure pump so that the flow may be from *h* to *g* or from *g* to *h*, and the pressure in the tank maintained by regulating valves.

When it is difficult to make slime settle, the Blaisdell pressure filter will be found extremely useful as a dewatering apparatus; or if water is scarce it may be used to quickly separate water from slime. The objectionable feature is opening the tank to remove the filter leaves for cleaning or repairs.

**The Kelly Pressure Filter.**—In construction and in method of operation the Kelly filter differs materially from the Blaisdell filter, and both from the filter press. As shown in Fig. 24 and Fig. 25, the Kelly pressure filter consists of a pressure tank, horizontally mounted on channel beams suitably supported; of a carrier mounted on a four-wheeled truck, having a supporting frame at the rear, and carrying the head of the pressure tank at the front; of a series of filter frames arranged vertically and supplied with pipes communicating with the interior of the filter leaves and projecting through the head of the tank to a manifold. Inside the tank there are two tracks, placed at suitable heights and fastened to the tank, on which the back wheels of the carrier run, while the tank-supporting beams afford an inclined track for the carrier wheels fastened to the



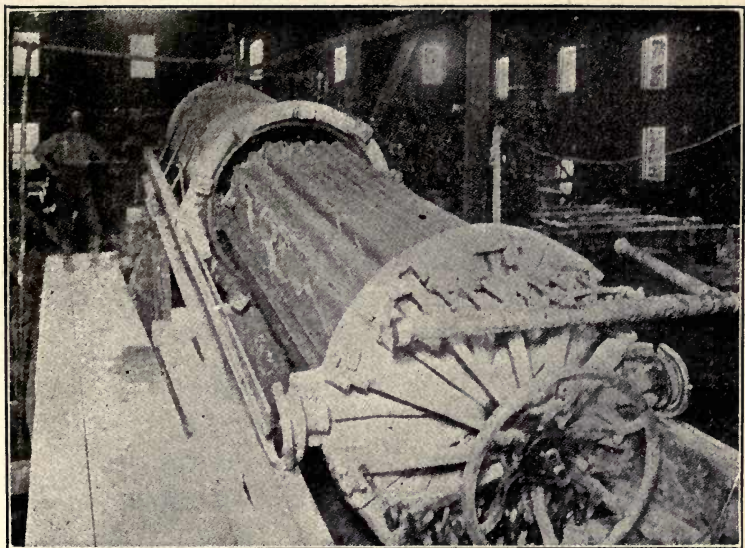

Fig. 24

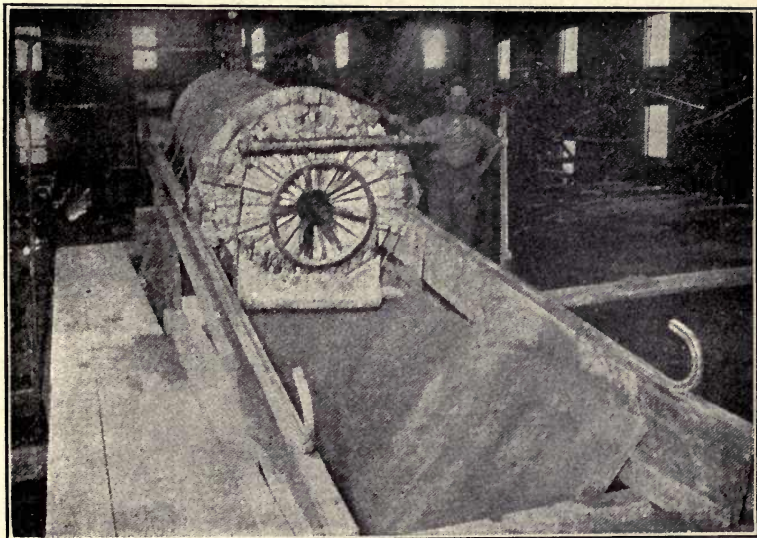

Fig. 25

head. This arrangement permits the carrier and filter frames to be readily moved in and out of the tank, since the mass of the accumulated slime cake on the filters is heavier than the counterweights, and when the cake is washed off the frames the counterweights assist in returning the carrier inside the tank. The head is locked to the tank by a number of radial levers, or spider legs, which engage with projecting lugs bolted to the cast-iron flanges attached to the tank. The inner ends of the levers are pivoted to a movable collar which is controlled by a central hand wheel on the head. By turning the hand wheel in the proper direction, the head can be clamped or unclamped to the tank, as it lengthens or shortens the spider legs.

The joint between the tank and head is made water-tight by a suitable gasket, and just before slime is charged the head is clamped and pipe connections for the slime and filtrate are made.

Slime pulp of proper consistency is now introduced, and when slime appears at an overflow pipe the tank is full. The overflow is now closed and the pressure is maintained at about 100 lbs. in the tank by means of a centrifugal pump, thus forcing the filtrate through the filter leaves, and out through the discharge pipes to the gold-solution tanks. The slime collects on the filter, and when it reaches the proper thickness,  $1\frac{1}{2}$  inches, the slime-pulp supply is cut off. The proper thickness



of a slime cake is determined by the pressure gauge and rate of outflow of the filtered solution. The excess of slime pulp is now forced from the tank through a suitable valve by compressed air, which at the same time serves to hold the slime cake on the filter. A weak cyanide wash solution follows next, and this being discharged, a water-wash is given to displace the weak solution in the slime cake.

The excess wash water having been returned to the water-supply tank the head is unclamped, the service pipes disconnected, and the carrier run out of the tank. By admitting low-pressure steam through the filtrate pipes to the interior of the filter leaves, the slime cakes are broken up and fall by gravity to the hopper underneath them. Water could be used with equally good results, but air is objectionable as the canvas is not braced to withstand internal pressure. The leaves are next washed, after which the carrier is returned to the tank for the next cycle of operations.

Under uniform conditions of consistency of slime pulp, and working pressure, the thickness of the cake will be quite even over the filters. If cakes exhibit any tendency to slough from the filters when pressure is cut off, suction may be applied to the pipe header communicating with the interior of the filters, and this will hold the cakes in place while the carrier runs out to the discharge hopper.

For simplicity of mechanical design, accessibility of all parts, and ease of operation, the Kelly pressure-filter must appeal to the metallurgist.

The time estimated for a cycle of operations is as follows:

	Minutes.
Filling tank with slime pulp.....	5
Filtering.....	15
Returning excess solution.....	5
Filling tank with wash solution.....	5
Filtering.....	15
Returning excess solution.....	5
Filling tank with wash water.....	5
Displacing wash solution.....	10
Returning excess water.....	5
Discharging cakes.....	15
	—
Total.....	85

One pressure filter 10×4 feet with 650 square feet filter area will handle 50 tons slime daily. The total weight of a machine of this capacity is about 6 tons, consequently is much lighter than the filter press of equal capacity. It also requires less space for operation than the vacuum filter.

**The Adair-Usher Slime Process.**—The Adair-Usher Process was introduced in South Africa during the early part of 1907. Since its introduction it has been adopted by some of the largest mines on the Rand, and is now

being introduced in the United States. The following advantages are claimed for this process:

1. The use of heavy or cumbersome filter-press machinery and parts is avoided.
2. The usual mechanical methods of agitation, circulation, and aeration are rendered unnecessary.
3. Plant construction is simplified and working costs reduced.
4. Repairs are reduced to a minimum.

The process is one of displacement and decantation, with none of the bad features of the old decantation process. When a cyanide solution is gradually and uniformly admitted beneath a mass of slime pulp, the liquid portion of the pulp will be displaced without the two liquids mixing except at the zone of contact; and if the feed of the cyanide solution is so regulated that it rises in the containing vessel slower than the rate of fall under free settling conditions of the solid particles, clear liquid may be drawn from the surface.

It is upon this principle that the Adair-Usher Process depends, and when the liquids are admitted uniformly there will be a clearly defined horizontal plane of demarkation between the water and solution.

A diagram of the apparatus and the arrangement of a plant is shown in Fig. 26.

It consists of a central vertical pipe from the lower end of which radiate perforated distributing pipes.

The lower end of the central pipe is connected with a distributing chamber, to which perforated pipes are screwed, so that they radiate from the center to the sides of the vat.

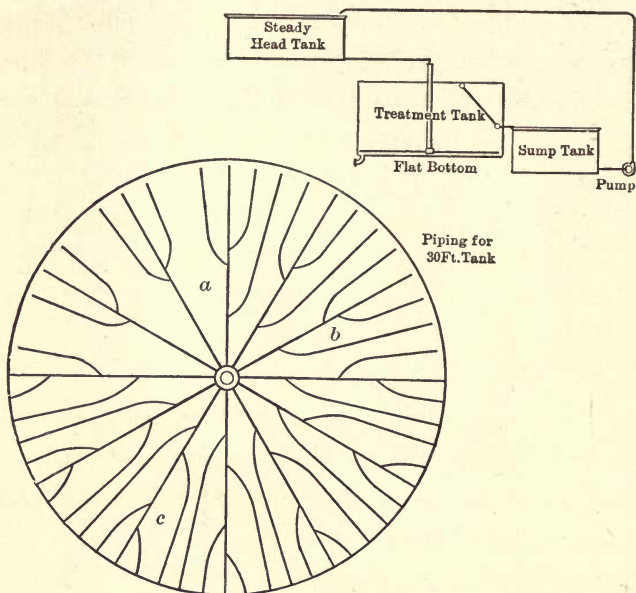

Fig. 26

Each pipe has a series of  $\frac{3}{16}$ -inch holes, drilled at regular spaced intervals in a perfectly straight line, and is fixed about 2.5 inches above the bottom of the tank. The number of radiating pipes is varied according to the diameter of the vat, and is regulated so that the distance between pipes at the periphery of the vat does not exceed 2 feet.

The arrangement of the pipes for 20, 30 and 40 foot vats is shown in the circular diagram, Fig. 26, *a*, *b*, and *c*. All the drill holes in the pipes are pointed at an angle of  $30^{\circ}$  toward the bottom of the vat, the object being to stir the slime from the bottom and not to cause ascending and descending currents as would occur if they were directed upward. Starting from the center of the vat the drill holes are spaced in the pipes as follows:

1 to 3 feet inclusive	.....	2 holes per foot.
4 to 7 " "	.....	3 " " "
8 to 15 " "	.....	4 " " "
16 to 17 " "	.....	5 " " "
18 to 25 " "	.....	6 " " "

If 8 feet from the center a triple branch occurs the number of holes on each pipe should be halved; or if the branching occurs at 18 feet the number of holes should be halved from there.

Agitation of slime is essential in cyanide treatment in order to continually present solution in fresh contact to each particle of slime, and this is accomplished in the Adair-Usher Process by particles of slime and solution continually passing each other.

Aeration of a charge of slime is accomplished by delivering the solution to the central column through a launder in such a way that air is trapped by the in-flowing liquid.



This air is distributed to the slime pulp through the holes in the pipes, and in rising through the slime in a multitude of minute bubbles it furnishes sufficient oxygen for the operation.

The operation of the process is about as follows:

1. The slime is collected in the settling vats.
2. The slime is transferred with cyanide solution to the treatment vats. Here the charge is aerated, circulated, and lixiviated until the gold is dissolved. The solution is admitted to the central pipe, so that there will always be a steady head.
3. When the treatment has continued a sufficient time to insure the gold being dissolved the circulation ceases, and the slime is allowed to settle from 3 to 6 inches.

Washing and decantation then commence, the rate being determined by the settlement of the slime. Washing is done with a weak solution from which gold has been precipitated, and is carried out until the solution is gold-free well above the precipitated solution. The rate of decantation and consequent washing depends upon the rate at which the slime settles, since only clear liquid is to be decanted.

4. Washing and decantation being completed, the slime is allowed to settle and the solution drawn from the tank goes to the next transfer of slime in the second operation.

It has been found that six times the quantity of solution to one of slimes is sufficient to displace the total of the gold-bearing solution.

If the time of treatment has been determined to be 72 hours, i.e., 48 hours washing and 24 hours final settlement and discharge, it will be necessary to decant from the charge a quantity of solution equal to 3.5 tons for every ton of dry slime contained in the charge.

If 100 tons of dry slime is to be treated, it will be necessary to displace 350 tons of solution in 48 hours, or from 7 to 8 tons per hour. Should at any time the quantity of clear solution exceed 6 to 7 inches, the operator can increase the quantity of solution used for washing.

The cost of the Usher apparatus is \$550 per tank 35 feet in diameter, and \$720 per tank for 55 feet in diameter on the Rand, a considerable reduction in cost should be made in the United States, and particularly if installed by the management of the mill.

**Nichols Slime Settling Process.\***—As far as the author knows no name has been suggested by Mr. H. G. Nichols for this double process of slime settling and cyaniding. The method is said to possess the following advantages: (1) Absence of pumps, carrying machinery, and com-

---

\* Trans. I. M. & M., Jan. 1908; Mining Science, April, 1908; Mining and Scientific Press, May, 1908; Electro-Chemical Industry, April, 1908.

plicated appliances; (2) the separation of sands from slime is not called for, and thus disadvantages attendant on dealing with such classes of material as depend upon close classification are obviated; (3) it is possible to wash to the best advantage and thus reduce the loss by residual moisture; (4) the degree of fineness or uniformity is immaterial; (5) the initial cost is very low, and niceties of adjustment are not requisite; (6) the only limit to the thickness of a charge is the point at which it will not run, and best results are obtained from charges with high percentages of solids; (7) the process may be continuous.

“One of the principal causes which retards the settlement of slime or finely divided material is held to be, in greater measure than has heretofore been appreciated, the accumulation of the slime itself in the process of settling.”

An increase of suspended matter causes a decrease in the rate of subsidence, and if the solid contents of the pulp is removed it furnishes an opportunity for the colloid hydrates to settle and without so great retardation. This experiment may be tried by taking a test-tube and dissolving a little ferric oxide in dilute hydrochloric acid, adding water to the solution, and precipitating ferric hydrate with ammonia. The brown flocculent precipitate settles readily if little iron is present, but very slowly if much iron is present.

“The principle of the process consists in removing the solid matter as fast as it reaches the bottom of a V-shaped tank in which it is settling.

The tank or separator is of inverted pyramidal shape, 4 ft.  $\times$  5 ft., and connects at the bottom through an 8-inch square aperture with a closed box in which a 10-inch belt is made to travel slowly. The method may be applied in practice in either of two ways: First, as an intermittent process in which the belt discharge of solids would be delivered into a second similar tank where a weak solution or wash-water could be sprayed on to the belt to loosen and disintegrate the slime, or a mixer may effect this purpose. After removal of the required proportion of solids the solution would be withdrawn to the original level and a second charge introduced. Secondly, the introduction of a suction-pipe near to the surface of the liquid in the separator permits of a continuous process being carried on. The percentage of moisture in the discharge is inversely as the proportion of solids in the separator charge, and the first portions of a discharge from any given separator charge are always better than succeeding portions; hence, if the density of the separator charge is maintained at its initial figure, the moisture in the discharge would be kept at a minimum and the rate of discharge increased. By an automatic periodical cutting off of the suction and application of small back pressure the filter-screen over the suction-pipe is kept

clear from caked slime and clear liquid is continually drawn from a pulp of specific gravity 1.4. The belt and suction must be so correlated that the solids discharged are proportionate to the liquid sucked out, and the discharge from a pulp of the density stated will uniformly contain about 22.5 per cent of moisture. If there be two suction-pipes with screens they are kept clear by back pressure being applied alternately to each. The continued use of screen suction would not be possible unless the solids were being extracted by the conveyor belt. The procedure in the wash settlers is practically the same. The solids are washed off the belt by precipitated solution and water, and the suctions withdraw an equal amount of liquid, which is passed through the extractor boxes and returned from the sump. In other processes completeness of washing is dependent on time and capacity of plant, as each installment of slime is taken separately and washed solution passed through it as long as economically possible, when it must be removed, whether well washed or not, to make room for the next installment; but in this method continuity is unimpeded and slimes may be washed out with any reasonable quantity of weak solution without affecting the time of treatment—the only factor affected being the capacity of the extractor boxes.



## CHAPTER XVII.

### GENERAL INFORMATION ON CYANIDING.

IN all mill work uniformity of product is desirable, but particularly is this the case in metallurgical work, to obtain the most satisfactory results. Of the two methods of crushing or stamping in use, namely, the wet and the dry, the wet has given the better results both in regard to uniformity of the grains and speed of crushing.

When wet crushing is practiced water is allowed to flow into the mortar of the stamp-mill and flow out through a screen. The size mesh used on these screens varies from sixty to one hundred for amalgamation, but for the cyanide process it has been in many instances possible to use 30-mesh screens and even very much coarser.

The size of the mesh of the screen determines the degree of fineness to which crushing is to be carried, as all fine particles which can pass the mesh are carried through by water, while all that cannot pass through remain in the mortar to be reduced in size until they can.

One of the obstacles to wet stamping is the quantity of water necessary to do the work of uniform crushing. This water has been in some instances returned from settling-tanks back into the mortar to be used again and again. While there are no objections to the use of this water, there are to pumping it. It is understood that with wet crushing water enough must be used to allow the sludge to flow through the screens. It is often to the advantage of the cyanide process that coarse crushing is allowable, both in regard to water used and time saved in crushing; still even this time advantage is sometimes more than counterbalanced by time lost in leaching with the cyanide solution when coarse crushing is practiced. For where time is saved in crushing, and subsequent drainage of water, the cyanide solution in some instances must remain longer in contact with ore being treated.

On the other hand, when fine crushing is practiced the water drains slowly from the settling-tanks, leaving the fine ore sometimes so firmly packed, if clayey or slimy, as to allow of almost no filtration, even when suction and other devices are employed to assist gravity. The average speed of drainage is about 12 inches per hour, which can be increased mechanically by means of vacuum-pumps. To assist drainage percolation vats are made of large diameter rather than deep, and are sloped from the outer circumference

towards the centre, although this slope is not very important if filter bottoms are properly constructed to allow the solutions to circulate freely under them.

The character of the ore will determine the degree of fineness in crushing. An open porous ore might be crushed to the size of a pea, while a compact ore with metal disseminated through it in grains may need to pass a 60-mesh or finer screen. If the metal is in porous or loose ore in the form of seams or streaks, coarse crushing will answer.

It is often necessary with refractory ores to use a preliminary treatment of lime to neutralize the acid salts which usually are found in partially oxidized pyritous ores, that are more or less dissoluble in water. Attempts have been made to neutralize these ores in the process of stamping by adding lime to the stamp-water. The objection to this proceeding is that a great degree of uncertainty must prevail as to the amount of lime required; and moreover, as the lime must be leached out of the ore by water later on, not much is to be gained, but considerable annoyance will be caused if too much lime finds its way into the ore.

Mr. A. B. Paul used a cyanide solution in the stamp-battery, the object being to take up gold as it was liberated from the ore, thus hastening the operation and lessening the amount of water waste.

There are several objections to this practice which make it unadvisable.

A loss of cyanide takes place with such practice, and as cyanide cannot dissolve the coarse gold, nothing is to be gained. Cyanide will act on mercury, but not on gold covered with mercury, hence its use in the mortar might have a tendency to prevent the mercury from keeping up to its work. According to one authority mercury is not dissolved or acted upon by potassium cyanide, but practice has proven otherwise, for at Mercur, where there is cinnabar in the ore, mercury is found in the slimes from the precipitation-box. Mercury has also been found in the slimes where tailings from amalgamation have been cyanided, as at the Waihi Mine, New Zealand.\* The ore in this latter instance is said to be practically free of base-metal sulphides.

**Conclusions for all Methods.**—It is not claimed by any one, probably, that all ores can be treated successfully by cyaniding, for such is not the case; but the process can treat any ore where as much care is taken with oxidation as in other processes and with equally good results.

There may be given as one reason why better results have not been obtained in the treatment of tail-

---

\* A. Wilson.

ings that amalgam on the surface of gold protects it to an enormous extent from the solvent action of potassium cyanide.

Another reason for bad results may be given, that not enough oxygen from the air was allowed to come in direct contact with the ore and solution.

The poor results obtained in the treatment of concentrates may be obviated by allowing more time for the cyanide solution to act upon them, or by finer pulverization. In both cases the action of the cyanide solution can be hastened by agitation.

**Advantages of Cyaniding.**—1. The plant required is comparatively inexpensive.

2. The extraction is arrived at without any previous ore treatment, except ordinary crushing, which must take place for every treatment.

3. The extraction is simple and quite complete; tailings can be treated successfully when failure has attended other processes.

4. The precious metals can be precipitated from the solution in various ways to suit the ideas of the operator, but the simplest way is by the electrical current with mercury cathode.

5. The simple cyanide process extracts only the fine gold, thus necessitating previous amalgamation with free milling, and longer contact with the solution, and very fine crushing with refractory ore. The electrical



method with mercury requires no previous amalgamation.

6. The cost of treatment is not so high as to deter the use of either process, and at times is quite reasonable, depending upon circumstances.

7. The factor time enters into competition with machinery on the one hand, while machinery enters into competition with time on the other. An important factor in favor of agitation is that the tanks can be cleared more readily for another operation; with percolation they must be shoveled or sluiced out.

8. Talcose and clayey ores, such as make leaching difficult even when mixed with sand, are readily treated by agitation and the electric process.

9. Failure to obtain satisfactory results has occurred from neglect on the part of the operator to properly neutralize the ore before applying the cyanide solution.

Failure has occurred in other instances because sufficient knowledge of the process was not possessed by the operator. Early experiments proved very unsatisfactory, especially in the South Atlantic States, where this process seems to have been tested before it had attained its present state of perfection, or rather before the intelligence now possessed upon the subject had been acquired by experiment.

**Cyanide of Potassium.**—The cost of cyanide 98 per cent pure is fifty cents per pound in New York City.

1 gram weighs 15.432 grains.

1 grain weighs .0648 gram.

Area of circle is the diameter squared, and this multiplied by the depth taken in the same multiple will give the cubic contents of a tank. If taken in inches, the answer will be in cubic inches; if taken in feet, the answer will be in cubic feet.

Circumference of a circle is the diameter multiplied by 3.1416.

Each cyanide vat should contain one day's ore. If the operation requires six days, there should be six vats. If each vat contains 50 tons of ore, it is a 50-ton daily plant.



## APPENDIX.

---

### INSTRUCTIONS HOW TO PROCEED WITH THE TREATMENT OF A CASE OF CYANIDE POISONING IN THE ABSENCE OF MEDICAL ASSISTANCE.

By J. C. JENKINS.

EVERYTHING depends on prompt action, for the chance of recovery is extremely small after the lapse of a very few minutes if a fatal dose has been taken. One person should be despatched for the nearest medical assistance that is available, but no delay in treatment should be permitted to occur on this account. The first care must be to neutralize the rapid poison by the antidote, and then to empty and wash out the stomach as soon and as completely as possible.

The antidote consists of two solutions sealed up in bottles and a sealed powder. The two solutions are to be first mixed together in the tin vessel in which they are packed, by breaking off the sealed ends of the bottles.

The tube containing the powder is also to be broken, the powder added to the mixture, and the dose is to be administered as soon as can possibly be done. If the patient is still conscious, he must drink the antidote at once without waiting for the insertion of the stomach tube; but if not conscious or not responsible, then a small gag must be firmly inserted between his teeth, so as to prevent the stomach tube from being bitten off, and the tube is then to be passed down his throat and into his stomach. The antidote is to be poured down the tube, and is then to be followed by some water.

In any case, either before or after the antidote has been taken, the stomach tube (found in the set) is to be inserted, and about half a pint of water is to be poured down it, the patient being placed in a reclining position, a little raised from the ground. The insertion of the tube may produce vomiting; this, however, is entirely favorable to the course of the treatment. When the last of the water is placed in the funnel, and before it has all descended into the tube, the funnel end of the latter is to be lowered so as to cause the tube to act as a syphon, and the stomach emptied as much as possible of its contents. Fresh water is to be poured down the tube, and the stomach again emptied, and this is to be repeated several times so as to thoroughly wash out the stomach. When this has been done the tube can be withdrawn.

If the tube be not at hand, every endeavor must be



made to induce vomiting after the administration of the antidote, while an equal endeavor must be made to cause the patient to swallow more of the antidote between the intervals of vomiting, if the administration be not already and completely made.

Vomiting may be induced by an emetic, like mustard, or by tickling the back of the throat with a clean feather, or a piece of clean india rubber tube, or the finger. An ample quantity of warm water should be swallowed and vomited, so as to wash out the stomach as in the previous case. Should warm water be not at hand, cold water may be employed in its place.

As soon as the stomach has been satisfactorily emptied and washed and the stomach tube withdrawn, steps should be taken to bring about artificial respiration should the patient appear to be in a state of collapse and his breathing have ceased to be noticeable. The application of smelling salts or of ammonia to his nostrils may itself induce breathing again; but if this be not immediately successful the patient should be treated as is done in cases of partial drowning or suffocation by Dr. Sylvester's method.

*Note.*—Dr. Sylvester's method for the recovery of the partially drowned or asphyxiated is as follows:

The patient is to be placed flat upon his back in the open air, with his chest and arms bare, and all tight clothing opened or removed. A pad, such as a coat rolled

up, is to be placed under his shoulders so as to cause the head to be thrown somewhat backwards. His tongue must be brought forward and as gently as possible, and either held back by an elastic band to his chin or tied with a clean string, so that it does not fall backwards to the back of the mouth and so close the passage to the windpipe. The operator, standing at the head of and looking at the patient, is then to take the arms of the patient by the wrists, one in each hand, and pull them straight out beyond his head, so as to expand the chest as much as possible, and count 1, 2, 3. The arms of the patient by this treatment have been, owing to the pad beneath his shoulders, pulled into the same attitude as though he had himself stretched out his arms straight above his head to the fullest extent and so expanded his chest. By now doubling the elbows of the patient against his chest, the operator must bring the arms back again, so as to expel the air from the lungs, counting 1, 2, 3. The operation is then to be repeated at the same rate as the operator is himself breathing, namely, about fifteen times a minute, so that the patient's lungs are filled and then emptied of air at the same rate as that at which he would breathe. Usually two operators should be at hand, the one to relieve the other, and in the interval of rest the second operator can attend to the tongue and see that it does not slip back. The artificial respiration so induced must be patiently continued for a long

time, even as long as an hour; but generally, in a short time the patient, if still alive, will commence to make slight convulsive efforts to himself get his breath, then the utmost care must be taken not to hinder him. The operators cease their effort as soon as the patient is trying to get his breath, and would only recommence if it were found that he again ceased breathing.

Medical assistance should by this time have arrived; indeed, if the patient be conscious, there is not great hope that the worst effects of the poison will have passed off, particularly if the details of the treatment have been all carried out, for cyanide poisoning is usually fatal within twenty minutes.

**Apparatus for the above First-aid Treatment.**—The package for treatment should consist of a tin vessel with lid, in which are packed

(a) A hermetically-sealed bottle, containing  $7\frac{1}{2}$  gm. ferrous sulphate dissolved in 30 cc. water; and

(b) A hermetically-sealed bottle, containing  $1\frac{1}{2}$  gm. of caustic soda dissolved in 300 cc. water; and

(c) A tube containing 2 gm. of magnesia.

There should be also a gag for the purpose of opening the clenched mouth of an unconscious person, and a stomach tube, that can be passed through the gag and down into the œsophagus into the patient's stomach. This is very easy to effect, but several persons in charge of the plant should receive instructions from the nearest

medical man as to how to insert a stomach tube, so that they know how to use it should occasion at any time arise.

The apparatus should never be allowed to be removed from its place, but always kept complete and ready for an emergency. It is advisable to keep it in duplicate, in prominently marked positions in the works.



# INDEX.

---

	PAGE
Acid, cyanhydric.....	28
Acid ores.....	8, 28
Acid, sulphuric. treatment of slimes.....	115
Acidity in ores.....	38
Adair-Usher process.....	216
Agitation.....	18, 74
“    processes.....	132
“    of slimes.....	132
“    tests.....	40, 72
Agitator, Blaisdell's.....	191
“    Hendryx's.....	192
Agitators, slime.....	191
Alkaline sulphides.....	10
Alternating currents.....	136
Aluminum.....	98
Amalgamation.....	1
Ampere.....	142
Ampere-hours.....	143
Anions.....	139
Anodes, 139; platinum, 165; carbon, 165; iron, 168; zinc.....	167
Antimony.....	9, 36
Arsenical ores.....	11
Assay, Crosse's method.....	52
Assay of solution for gold and silver.....	51
Auriferous sulphurets.....	125
Base-metal ores.....	8
“    salts.....	12, 28
Battery plates.....	2
Bismuth.....	37



	PAGE
Blaisdell agitator .....	191
" distributor .....	189
" pressure filter .....	209
Bottom discharge-valve .....	62
Bosqui, F. L. ....	103
Bromide .....	19
Bullion from cyaniding .....	119
Butters' pulp-distributor .....	65, 189
" vacuum filter .....	205
Calculation of wires .....	162
Carbonate of copper .....	9
Carbon anodes .....	165
" dioxide .....	31
Cathode .....	170
Cause of non-extraction .....	36
Caustic lime .....	77
" potash .....	27, 98
" soda .....	77
Charcoal .....	32
" precipitation .....	87
Charging vats .....	63
Chemical deductions .....	25
" effects .....	100
" processes .....	26
Chemicals for oxidation .....	19
Chemistry of the operation .....	25
Chloride of silver .....	6, 85
Chlorination process .....	12
Chlorine water .....	21
Christy's experiments .....	20
Coarse crushing .....	6
Cobalt .....	12
Commercial cyanide .....	43
Concentrates .....	3, 55, 126
Conductivity of solutions .....	158
Copper-plate cathodes .....	172

	PAGE
Copper ores.....	9, 10
" sulphate.....	34
" in zinc-boxes.....	101
Cost of electrocyaniding.....	163
" " cyanide plant.....	71
Crookes, Wm.....	137
Crosse's gold assay for gold.....	52
Crushing, dry.....	6
Cuprous salt precipitation.....	89
Current and molecular weight.....	141
Current.....	160
Current strength.....	142
Cyanicides.....	28
Cyanide consumption.....	32, 39
" " tests for.....	39, 52
" " determination.....	33, 39, 52, 53
" extraction.....	40
" plant.....	55
" poisoning, treatment for.....	233
" process, scope of.....	34, 53
Cyaniding slime.....	187
Cyanogen and oxygen.....	22
Cyanogen bromide.....	19
Cyanide solutions, assay of.....	51
" " making up.....	43
" " stock.....	44
" " strong.....	45
" " tests.....	52
Decantation of slimes.....	129
" process.....	129, 193
Dehydrating roast.....	12
Determination of acidity.....	38
" " consumption.....	33
" " cyanide.....	49
" " ferri cyanide.....	50
" " ferro- ".....	50
" " free potassium cyanide.....	45
" " free hydrocyanic acid.....	48
" " non-extraction.....	36

	PAGE
Dilute solutions .....	16, 78
Discharge-valves .....	61
Distributor, Blaisdell's .....	189
Drainage.....	7
Dry crushing.....	6, 71, 128
Electrical horse-power.....	144
"    precipitation.....	141
Electricity and oxygen.....	146
Electrocyaniding.....	135, 145
"    cost of.....	163
"    objections to.....	164
Electrodes.....	151
Electrolysis.....	138
Electrolyte.....	146
Elsner's equation .....	14, 27
Energy of current.....	141
Evaporation .....	28
Extraction.....	17, 23, 40
"    determination of.....	36-40
Ferri-cyanide.....	30
"    tests for.....	50
Ferri oxide.....	30
Ferro-cyanide.....	30, 50
"    test for.....	50
Ferrous oxide .....	29
Ferrous sulphate.....	29, 33
Filling vats .....	63
Filter-press, slime treatment .....	131, 195
Fine ore.....	7, 37
"    "    values in.....	4
Filter bottoms.....	60
"    press.....	131
"    press, slime treatment.....	131
"    tanks.....	123
"    vacuum.....	70, 123
Fitness of ores for cyaniding.....	7
Float gold.....	4
Flow of electricity.....	142

	PAGE
Flow through electric precipitation-boxes.....	176
" through zinc           "           " .....	99
Flux for gold precipitates.....	119
Free hydrocyanic acid test.....	48
Free-milling ores.....	I
Galena.....	10
Gas coke.....	166
Gilmour-Young process.....	132
Gold, coarse.....	6, 36
" float.....	4
" flux.....	119
" free-milling.....	I
" precipitates.....	118
Gold, refractory.....	2
" slime treatment.....	108, 111, 115, 119
" solution.....	99
Graphite.....	133
Haney's experiments.....	16, 135
Hendryx agitator.....	192
Hydrogen peroxide.....	19
Impurities in solutions.....	4, 99
Injectors.....	68
Intermediate filling.....	65
Iodine.....	21
Iodide of silver.....	52
Ions.....	139
Iron anodes.....	168
" sulphate.....	28, 33
" sulphides.....	28
" tanks.....	31
Kelly pressure filter.....	212
Laboratory samples.....	40
" tests.....	38
Lathe for cutting zinc shavings.....	97
Leaching.....	74, 76
" vats.....	57

	PAGE
Lead acetate.....	100
" cathodes.....	174
" in zinc.....	100
Launders.....	69
Lime.....	75
Location of plants.....	56
MacArthur Forrester patents.....	15
Magnesia.....	12
Making up solutions.....	41
Manganese.....	12
McLauren's experiments.....	16
Melting precipitates.....	118
Moore's vacuum filter.....	202
Neutralizers.....	28, 53, 75
Nickel.....	12
Nichol's slime process.....	216
Objections to zinc precipitation.....	101
Ohm.....	144
Ores, acid.....	8
" antimony.....	9, 36
" arsenic.....	11
" base metal.....	8
" concentrates, copper.....	9, 10
" discharging.....	61
" fineness of.....	7
" free-milling.....	1
" lead.....	12
" Manganese.....	12
" porous.....	7
" refractory.....	2
" roasting.....	12
" screening.....	5
" slimes.....	4
" suitable for process.....	1, 13
" sulphides.....	10, 28
" sulphurets.....	125
" refractory.....	2
" roasting.....	12, 83



	PAGE
Ores, tailings.....	3
"  tellurium.....	II, 23
"  zinc.....	10
Oxygen and cyanide.....	15
Oxidation, chemicals for.....	19
Paracyanogen.....	22
Patents.....	15
Pelatan-Clerici cathode.....	183
"  "  process.....	175
Percentage of extraction.....	40
Percolation tests.....	41
Peroxide, barium.....	19
"  hydrogen.....	19
"  lead.....	19
"  manganese.....	19
"  sodium.....	19
Pickling zinc.....	100
Pipes.....	69
Plant.....	55, 70
Platinum anodes.....	165
Pneumatic cyanide process.....	133
Poisoning, treatment for cyanide.....	233
Porous ores.....	/
Potassium amalgam.....	87
"  bichromate.....	19
"  chlorate.....	19
"  cyanide.....	41
"  hydrate.....	27
"  nitrate.....	19
"  sulphate.....	75
"  sulphide.....	II, 75
"  zinc cyanide.....	49, 95
Preliminary washing.....	75
Precipitating-boxes, electrical.....	176
"  "  zinc.....	68
Precipitating by charcoal.....	87
"  by copper salts.....	89
"  by electricity.....	176, 183
"  gold.....	86, 114

	PAGE
Precipitating potassium amalgam.....	87
"    by sodium amalgam.....	86
"    zinc.....	94, 96
"    zinc fume.....	114
Process described.....	53
"    electro-cyanide.....	145
"    Gilmour-Young.....	132
"    Hanney's.....	16
"    MacArthur-Forrest.....	15
"    Nichols'.....	216
"    Pelatan-Clerici.....	178
"    Siemens-Halske.....	175
"    Rae's.....	77
"    vacuum filter.....	201
Preliminary treatment.....	77
"    washing.....	36, 77
Pyrites.....	28
Reaction pulp-distributor.....	65
Recovery of gold.....	152
Refractory ores.....	2
Roast, calcining.....	12
"    chloridizing.....	12
"    dead.....	84
"    dehydrating.....	12, 83
"    oxidizing.....	12, 84
Roasting precipitates.....	117
"    ores.....	12, 83
"    silver.....	84
"    tellurides.....	11
Roll crushing.....	6
Scope of process.....	13, 26
Schiedel, A.....	126
Screening.....	5
Settling-boxes.....	129
Settling-tanks.....	4
Side discharge-valves.....	61
Siemens-Halske process.....	175

	PAGE
Silver chloride .....	6
" deposition .....	85
" extraction.....	84
" iodide test.....	52
" nitrate solutions.....	47, 53
Size of anodes .....	161
" " cathodes .....	161, 173, 176
" " leaching-vats .....	57
Sizing .....	5
Slimes .....	4
" decantation of.....	129
Slime treatment.....	110, 128, 131
" values.....	4
" water for. ....	131
Sluicing tailings.....	70
Specifications for plant.....	71
Soaking ore.....	64, 76
Sodium amalgam.....	86
" chloride .....	159, 179
" hydrate.....	49
" peroxide.....	19
Solutions, KCN.....	44
Solutions for leaching.....	43
" weak.....	45
Stamping, dry .....	6
Standardizing solutions.....	44, 52
Standardizing silver nitrate solutions.....	46, 53
Standard solutions.....	44
Stock solutions.....	44
Strong solutions .....	44
Storage tanks.....	44, 70
Sulphate of zinc.....	122
Sulphides .....	22, 125
Sulphurets.....	125
Sulphuric acid.....	28, 35, 90
" " treatment of gold slimes.....	120
Suluman, H. L .....	116
Sweetland filter-press .....	196
Tailings .....	3, 55
" treatment .....	121

	PAGE
Tank, Pelatan-Clerici.....	178
Tanks, gold solution.....	70
" vacuum filter.....	68, 123
Tellurides.....	II, 23
Test for alkalis.....	77
" " cyanide.....	52, 53
" " free acid.....	48
" " gold.....	51
" " silver.....	51
Testing with silver nitrate.....	53
Time factor.....	81
Time of drainage.....	82
" " leaching.....	81
Titration.....	47, 53
Treatment of bullion.....	113
Vacuum filter.....	68
" filter process.....	201
" pump.....	69, 123
Vats.....	59
Vat capacity.....	58
" construction.....	56
" filling.....	63
Vat foundations.....	66
" steel.....	31
" wooden.....	59
Voltage.....	143, 161
Washing ore.....	77
Water, decomposition.....	142
" for leaching.....	65
" " slimes.....	66
Watt.....	144
Wires, calculation of.....	162
Zinc.....	103
" amalgam.....	94
" and lead.....	100
" anodes.....	167
" and strong solutions.....	94

INDEX.

247

	PAGE
Zinc blende.....	10
“ box.....	68, 108
“ box slimes.....	67
“ consumption.....	101
“ cost of.....	105
“ fume precipitation.....	114
“ lathe.....	97
“ objections to . . . . .	99
“ oxide . . . . .	100
zinc-potassic cyanide.....	27
“ precipitation.....	65, 94
“ “ advantages . . . . .	101
“ “ hindrances to.....	100
“ “ objections to.....	101
“ shavings.....	96
“ sulphate.....	34, 122







# SHORT-TITLE CATALOGUE

OF THE

PUBLICATIONS

OF

JOHN WILEY & SONS,

NEW YORK.

LONDON: CHAPMAN & HALL, LIMITED.

ARRANGED UNDER SUBJECTS.

Descriptive circulars sent on application. Books marked with an asterisk (\*) are sold at *net* prices only. All books are bound in cloth unless otherwise stated.

## AGRICULTURE—HORTICULTURE—FORESTRY.

Armsby's Manual of Cattle-feeding. . . . .	12mo,	\$1 75
Principles of Animal Nutrition. . . . .	8vo,	4 00
Budd and Hansen's American Horticultural Manual:		
Part I. Propagation, Culture, and Improvement. . . . .	12mo,	1 50
Part II. Systematic Pomology. . . . .	12mo,	1 50
Elliott's Engineering for Land Drainage. . . . .	12mo,	1 50
Practical Farm Drainage. . . . .	12mo,	1 00
Graves's Forest Mensuration. . . . .	8vo,	4 00
Green's Principles of American Forestry. . . . .	12mo,	1 50
Grotenfelt's Principles of Modern Dairy Practice. (Woll.) . . . . .	12mo,	2 00
* Herrick's Denatured or Industrial Alcohol. . . . .	8vo,	4 00
Kemp and Waugh's Landscape Gardening. (New Edition, Rewritten. In Preparation).		
* McKay and Larsen's Principles and Practice of Butter-making . . . . .	8vo,	1 50
Maynard's Landscape Gardening as Applied to Home Decoration. . . . .	12mo,	1 50
Quaintance and Scott's Insects and Diseases of Fruits. (In Preparation).		
Sanderson's Insects Injurious to Staple Crops. . . . .	12mo,	1 50
* Schwarz's Longleaf Pine in Virgin Forests. . . . .	12mo,	1 25
Stockbridge's Rocks and Soils. . . . .	8vo,	2 50
Winton's Microscopy of Vegetable Foods. . . . .	8vo,	7 50
Woll's Handbook for Farmers and Dairyemen. . . . .	16mo,	1 50

## ARCHITECTURE.

Baldwin's Steam Heating for Buildings. . . . .	12mo,	2 50
Berg's Buildings and Structures of American Railroads. . . . .	4to,	5 00
Birkmire's Architectural Iron and Steel. . . . .	8vo,	3 50
Compound Riveted Girders as Applied in Buildings. . . . .	8vo,	2 00
Planning and Construction of American Theatres. . . . .	8vo,	3 00
Planning and Construction of High Office Buildings. . . . .	8vo,	3 50
Skeleton Construction in Buildings. . . . .	8vo,	3 00
Briggs's Modern American School Buildings. . . . .	8vo,	4 00
Byrne's Inspection of Material and Workmanship Employed in Construction.		
	16mo,	3 00
Carpenter's Heating and Ventilating of Buildings. . . . .	8vo,	4 00

* Corthell's Allowable Pressure on Deep Foundations. . . . .	12mo,	1 25
Freitag's Architectural Engineering. . . . .	8vo	3 50
Fireproofing of Steel Buildings. . . . .	8vo,	2 50
French and Ives's Stereotomy. . . . .	8vo,	2 50
Gerhard's Guide to Sanitary House-Inspection. . . . .	16mo,	1 00
* Modern Baths and Bath Houses. . . . .	8vo,	3 00
Sanitation of Public Buildings. . . . .	12mo,	1 50
Theatre Fires and Panics. . . . .	12mo,	1 50
Holley and Ladd's Analysis of Mixed Paints, Color Pigments, and Varnishes		
Large 12mo,		2 50
Johnson's Statics by Algebraic and Graphic Methods. . . . .	8vo,	2 00
Kellaway's How to Lay Out Suburban Home Grounds. . . . .	8vo,	2 00
Kidder's Architects' and Builders' Pocket-book. . . . .	16mo, mor.,	5 00
Maire's Modern Pigments and their Vehicles. . . . .	12mo,	2 00
Merrill's Non-metallic Minerals: Their Occurrence and Uses. . . . .	8vo,	4 00
Stones for Building and Decoration. . . . .	8vo,	5 00
Monckton's Stair-building. . . . .	4to,	4 00
Patton's Practical Treatise on Foundations. . . . .	8vo,	5 00
Peabody's Naval Architecture. . . . .	8vo,	7 50
Rice's Concrete-block Manufacture. . . . .	8vo,	2 00
Richey's Handbook for Superintendents of Construction. . . . .	16mo, mor.,	4 00
* Building Mechanics' Ready Reference Book:		
* Building Foreman's Pocket Book and Ready Reference. (In		
Preparation).		
* Carpenters' and Woodworkers' Edition. . . . .	16mo, mor.	1 50
* Cement Workers and Plasterer's Edition. . . . .	16mo, mor.	1 50
* Plumbers', Steam-Filters', and Tanners' Edition. . . . .	16mo, mor.	1 50
* Stone- and Brick-masons' Edition. . . . .	16mo, mor.	1 50
Sabin's Industrial and Artistic Technology of Paints and Varnish. . . . .	8vo,	3 00
Siebert and Biggin's Modern Stone-cutting and Masonry. . . . .	8vo,	1 50
Snow's Principal Species of Wood. . . . .	8vo,	3 50
Towne's Locks and Builders' Hardware. . . . .	18mo, mor.	3 00
Wait's Engineering and Architectural Jurisprudence. . . . .	8vo,	6 00
Sheep,		6 50
Law of Contracts. . . . .	8vo,	3 00
Law of Operations Preliminary to Construction in Engineering and Archi-		
tecture. . . . .	8vo,	5 00
Sheep,		5 50
Wilson's Air Conditioning. . . . .	12mo,	1 50
Worcester and Atkinson's Small Hospitals, Establishment and Maintenance,		
Suggestions for Hospital Architecture, with Plans for a Small Hospital.		
12mo,		1 25

## ARMY AND NAVY.

Bernadou's Smokeless Powder, Nitro-cellulose, and the Theory of the Cellulose		
Molecule. . . . .	12mo,	2 50
Chase's Art of Pattern Making. . . . .	12mo,	2 50
Screw Propellers and Marine Propulsion. . . . .	8vo,	3 00
Cloke's Gunner's Examiner. . . . .	8vo,	1 50
Craig's Azimuth. . . . .	4to,	3 50
Crehore and Squier's Polarizing Photo-chronograph. . . . .	8vo,	3 00
* Davis's Elements of Law. . . . .	8vo,	2 50
* Treatise on the Military Law of United States. . . . .	8vo,	7 00
Sheep,		7 50
De Brack's Cavalry Outpost Duties. (Carr.) . . . . .	24mo, mor.	2 00
* Dudley's Military Law and the Procedure of Courts-martial. . . . .	Large 12mo,	2 50
Durand's Resistance and Propulsion of Ships. . . . .	8vo,	5 00



* Dyer's Handbook of Light Artillery. . . . .	12mo,	3 00
Eissler's Modern High Explosives. . . . .	8vo,	4 00
* Fiebeger's Text-book on Field Fortification. . . . .	Large 12mo,	2 00
Hamilton and Bond's The Gunner's Catechism . . . . .	18mo,	1 00
* Hoff's Elementary Naval Tactics. . . . .	8vo,	1 50
Ingalls's Handbook of Problems in Direct Fire. . . . .	8vo,	4 00
* Lissak's Ordnance and Gunnery. . . . .	8vo,	6 00
* Ludlow's Logarithmic and Trigonometric Tables . . . . .	8vo,	1 00
* Lyons's Treatise on Electromagnetic Phenomena. Vols. I. and II. . . . .	8vo, each,	6 00
* Mahan's Permanent Fortifications. (Mercur.) . . . . .	8vo, half mor.	7 50
Manual for Courts-martial. . . . .	16mo, mor.	1 50
* Mercur's Attack of Fortified Places. . . . .	12mo,	2 00
* Elements of the Art of War. . . . .	8vo,	4 00
Metcalf's Cost of Manufactures—And the Administration of Workshops. . . . .	8vo,	5 00
* Ordnance and Gunnery. 2 vols. . . . .	Text 12mo, Plates atlas form	5 00
Nixon's Adjutants' Manual. . . . .	24mo,	1 00
Peabody's Naval Architecture. . . . .	8vo,	7 50
* Phelps's Practical Marine Surveying. . . . .	8vo,	2 50
Powell's Army Officer's Examiner. . . . .	12mo,	4 00
Sharpe's Art of Subsisting Armies in War. . . . .	18mo, mor.	1 50
* Tupes and Poole's Manual of Bayonet Exercises and Musketry Fencing. . . . .	24mo, leather,	5 00
* Weaver's Military Explosives. . . . .	8vo,	3 00
Woodhull's Notes on Military Hygiene. . . . .	16mo,	1 50

## ASSAYING.

Betts's Lead Refining by Electrolysis. . . . .	8vo,	4 00
Fletcher's Practical Instructions in Quantitative Assaying with the Blowpipe. . . . .	16mo, mor.	1 50
Furman's Manual of Practical Assaying. . . . .	8vo,	3 00
Lodge's Notes on Assaying and Metallurgical Laboratory Experiments. . . . .	8vo,	3 00
Low's Technical Methods of Ore Analysis. . . . .	8vo,	3 00
Miller's Cyanide Process. . . . .	12mo,	1 00
Manual of Assaying. . . . .	12mo,	1 00
Minet's Production of Aluminum and its Industrial Use. (Waldo.) . . . . .	12mo,	2 50
O'Driscoll's Notes on the Treatment of Gold Ores. . . . .	8vo,	2 00
Ricketts and Miller's Notes on Assaying. . . . .	8vo,	3 00
Robine and Lenglen's Cyanide Industry. (Le Clerc.) . . . . .	8vo,	4 00
Ulke's Modern Electrolytic Copper Refining. . . . .	8vo,	3 00
Wilson's Chlorination Process. . . . .	12mo,	1 50
Cyanide Processes. . . . .	12mo,	1 50

## ASTRONOMY.

Comstock's Field Astronomy for Engineers. . . . .	8vo,	2 50
Craig's Azimuth. . . . .	4to,	3 50
Crandall's Text-book on Geodesy and Least Squares. . . . .	8vo,	3 00
Doolittle's Treatise on Practical Astronomy. . . . .	8vo,	4 00
Gore's Elements of Geodesy. . . . .	8vo,	2 50
Hayford's Text-book of Geodetic Astronomy. . . . .	8vo,	3 00
Merriman's Elements of Precise Surveying and Geodesy. . . . .	8vo,	2 50
* Michie and Harlow's Practical Astronomy. . . . .	8vo,	3 00
Rust's Ex-meridian Altitude, Azimuth and Star-Finding Tables. (In Press.) . . . . .		
* White's Elements of Theoretical and Descriptive Astronomy . . . . .	12mo,	2 00

## CHEMISTRY.

<b>Abderhalden's Physiological Chemistry in Thirty Lectures.</b> (Hall and Defren). (In Press.)		
* <b>Abegg's Theory of Electrolytic Dissociation.</b> (von Ende.)	12mo,	1 25
<b>Adriance's Laboratory Calculations and Specific Gravity Tables.</b>	12mo,	1 25
<b>Alexeyeff's General Principles of Organic Syntheses.</b> (Matthews.)	8vo,	3 00
<b>Allen's Tables for Iron Analysis.</b>	8vo,	3 00
<b>Arnold's Compendium of Chemistry.</b> (Mandel.)	Large 12mo,	3 50
<b>Association of State and National Food and Dairy Departments, Hartford Meeting, 1906.</b>	8vo,	3 00
<b>Jamestown Meeting, 1907.</b>	8vo,	3 00
<b>Austen's Notes for Chemical Students</b>	12mo,	1 50
<b>Baskerville's Chemical Elements.</b> (In Preparation).		
<b>Bernadou's Smokeless Powder.—Nitro-cellulose, and Theory of the Cellulose Molecule.</b>	12mo,	2 50
* <b>Blanchard's Synthetic Inorganic Chemistry.</b>	12mo,	1 00
* <b>Browning's Introduction to the Rarer Elements.</b>	8vo,	1 50
<b>Brush and Penfield's Manual of Determinative Mineralogy.</b>	8vo,	4 00
* <b>Claassen's Beet-sugar Manufacture.</b> (Hall and Rolfe.)	8vo,	3 00
<b>Classen's Quantitative Chemical Analysis by Electrolysis.</b> (Boltwood.)	8vo,	3 00
<b>Cohn's Indicators and Test-papers.</b>	12mo,	2 00
<b>Tests and Reagents.</b>	8vo,	3 00
* <b>Danneel's Electrochemistry.</b> (Merriam.)	12mo,	1 25
<b>Duhem's Thermodynamics and Chemistry.</b> (Burgess.)	8vo,	4 00
<b>Eakle's Mineral Tables for the Determination of Minerals by their Physical Properties</b>	8vo,	1 25
<b>Eissler's Modern High Explosives.</b>	8vo,	4 00
<b>Effront's Enzymes and their Applications.</b> (Prescott.)	8vo,	3 00
<b>Erdmann's Introduction to Chemical Preparations.</b> (Dunlap.)	12mo,	1 25
* <b>Fletcher's Physiology of Alimentation.</b>	Large 12mo,	2 00
<b>Fletcher's Practical Instructions in Quantitative Assaying with the Blowpipe.</b>	12mo, mor.	1 50
<b>Fowler's Sewage Works Analyses.</b>	12mo,	2 00
<b>Fresenius's Manual of Qualitative Chemical Analysis.</b> (Wells.)	8vo,	5 00
<b>Manual of Qualitative Chemical Analysis. Part I. Descriptive.</b> (Wells.)	8vo,	3 00
<b>Quantitative Chemical Analysis.</b> (Cohn.) 2 vols.	8vo,	12 50
<b>When Sold Separately, Vol. I, \$6. Vol. II, \$8.</b>		
<b>Fuertes's Water and Public Health.</b>	12mo,	1 50
<b>Furman's Manual of Practical Assaying.</b>	8vo,	3 00
* <b>Getman's Exercises in Physical Chemistry.</b>	12mo,	2 00
<b>Gill's Gas and Fuel Analysis for Engineers.</b>	12mo,	1 25
* <b>Gooch and Browning's Outlines of Qualitative Chemical Analysis.</b>	Large 12mo,	1 25
<b>Grotenfelt's Principles of Modern Dairy Practice.</b> (Woll.)	12mo,	2 00
<b>Groth's Introduction to Chemical Crystallography</b> (Marshall)	12mo,	1 25
<b>Hammarsten's Text-book of Physiological Chemistry.</b> (Mandel.)	8vo,	4 00
<b>Hanausek's Microscopy of Technical Products.</b> (Winton.)	8vo,	5 00
* <b>Haskins and Macleod's Organic Chemistry</b>	12mo,	2 00
<b>Helm's Principles of Mathematical Chemistry.</b> (Morgan.)	12mo,	1 50
<b>Hering's Ready Reference Tables (Conversion Factors).</b>	16mo, mor.	2 50
* <b>Herrick's Denatured or Industrial Alcohol.</b>	8vo,	4 00
<b>Hinds's Inorganic Chemistry.</b>	8vo,	3 00
* <b>Laboratory Manual for Students</b>	12mo,	1 00
* <b>Holleman's Laboratory Manual of Organic Chemistry for Beginners.</b> (Walker.)	12mo,	1 00
<b>Text-book of Inorganic Chemistry.</b> (Cooper.)	8vo,	2 50
<b>Text-book of Organic Chemistry.</b> (Walker and Mott.)	8vo,	2 50
<b>Holley and Ladd's Analysis of Mixed Paints, Color Pigments, and Varnishes.</b>	Large 12mo	2 50



Hopkins's Oil-chemists' Handbook.....	8vo,	3 00
Iddings's Rock Minerals .....	8vo,	5 00
Jackson's Directions for Laboratory Work in Physiological Chemistry.	8vo,	1 25
Johannsen's Determination of Rock-forming Minerals in Thin Sections...	8vo,	4 00
Keep's Cast Iron. ....	8vo,	2 50
Ladd's Manual of Quantitative Chemical Analysis.....	12mo,	1 00
Landauer's Spectrum Analysis. (Tingle.).....	8vo,	3 00
* Langworthy and Austen's Occurrence of Aluminium in Vegetable Products, Animal Products, and Natural Waters.....	8vo,	2 00
Lassar-Cohn's Application of Some General Reactions to Investigations in Organic Chemistry. (Tingle.).....	12mo,	1 00
Leach's Inspection and Analysis of Food with Special Reference to State Control. ....	8vo,	7 50
Löb's Electrochemistry of Organic Compounds. (Lorenz.).....	8vo,	3 00
Lodge's Notes on Assaying and Metallurgical Laboratory Experiments...	8vo,	3 00
Low's Technical Method of Ore Analysis.....	8vo,	3 00
Lunge's Techno-chemical Analysis. (Cohn.).....	12mo	1 00
* McKay and Larsen's Principles and Practice of Butter-making .....	8vo,	1 50
Maire's Modern Pigments and their Vehicles.....	12mo,	2 00
Mandel's Handbook for Bio-chemical Laboratory .....	12mo,	1 50
* Martin's Laboratory Guide to Qualitative Analysis with the Blowpipe ..	12mo,	60
Mason's Examination of Water. (Chemical and Bacteriological.)...	12mo,	1 25
Water-supply. (Considered Principally from a Sanitary Standpoint.)	8vo,	4 00
Matthews's The Textile Fibres. 2d Edition, Rewritten.....	8vo,	4 00
Meyer's Determination of Radicles in Carbon Compounds. (Tingle.) ..	12mo,	1 00
Miller's Cyanide Process.....	12mo,	1 00
Manual of Assaying.....	12mo,	1 00
Minet's Production of Aluminum and its Industrial Use. (Waldo.)...	12mo,	2 50
Mixer's Elementary Text-book of Chemistry. ....	12mo,	1 50
Morgan's Elements of Physical Chemistry.....	12mo,	3 00
Outline of the Theory of Solutions and its Results.....	12mo,	1 00
* Physical Chemistry for Electrical Engineers.....	12mo,	1 50
Morse's Calculations used in Cane-sugar Factories.....	16mo, mor.	1 50
* Muir's History of Chemical Theories and Laws .....	8vo,	4 00
Mullikøn's General Method for the Identification of Pure Organic Compounds.		
Vol. I.....	Large 8vo,	5 00
O'Driscoll's Notes on the Treatment of Gold Ores. ....	8vo,	2 00
Ostwald's Conversations on Chemistry. Part One. (Ramsey.).....	12mo,	1 50
" " " " Part Two. (Turnbull.).....	12mo,	2 00
* Palmer's Practical Test Book of Chemistry .....	12mo,	1 00
* Pauli's Physical Chemistry in the Service of Medicine. (Fischer.)...	12mo,	1 25
* Penfield's Notes on Determinative Mineralogy and Record of Mineral Tests.	8vo, paper,	50
Tables of Minerals, Including the Use of Minerals and Statistics of Domestic Production.....	8vo,	1 00
Pictet's Alkaloids and their Chemical Constitution. (Biddle.).....	8vo,	5 00
Poole's Calorific Power of Fuels.....	8vo,	3 00
Prescott and Winslow's Elements of Water Bacteriology, with Special Reference to Sanitary Water Analysis.....	12mo,	1 50
* Reisig's Guide to Piece-dyeing. ....	8vo,	25 00
Richards and Woodman's Air, Water, and Food from a Sanitary Standpoint.	8vo,	2 00
Ricketts and Miller's Notes on Assaying. ....	8vo,	3 00
Rideal's Disinfection and the Preservation of Food.....	8vo,	4 00
Sewage and the Bacterial Purification of Sewage. ....	8vo,	4 00
Riggs's Elementary Manual for the Chemical Laboratory.....	8vo,	1 25
Robine and Lenglen's Cyanide Industry. (Le Clerc.).....	8vo,	4 00
Ruddiman's Incompatibilities in Prescriptions. ....	8vo,	2 00
Whys in Pharmacy .....	12mo,	1 00



* Ives's Adjustments of the Engineer's Transit and Level. . . . .	16mo, Bds.	25
Ives and Hilts's Problems in Surveying . . . . .	16mo, mor.	1 50
Johnson's (J. B.) Theory and Practice of Surveying. . . . .	Small 8vo,	4 00
Johnson's (L. J.) Statics by Algebraic and Graphic Methods. . . . .	8vo,	2 00
Kinnicutt, Winslow and Pratt's Purification of Sewage. (In Preparation).		
Laplace's Philosophical Essay on Probabilities. (Truscott and Emory.)	12mo,	2 00
Mahan's Descriptive Geometry. . . . .	8vo,	1 50
Treatise on Civil Engineering. (1873.) (Wood.) . . . . .	8vo,	5 00
Merriman's Elements of Precise Surveying and Geodesy. . . . .	8vo,	2 50
Merriman and Brooks's Handbook for Surveyors. . . . .	16mo, mor.	2 00
Morrison's Elements of Highway Engineering. (In Press.)		
Nugent's Plane Surveying. . . . .	8vo,	3 50
Ogden's Sewer Design. . . . .	12mo,	2 00
Parsons's Disposal of Municipal Refuse. . . . .	8vo,	2 00
Patton's Treatise on Civil Engineering. . . . .	8vo, half leather,	7 50
Reed's Topographical Drawing and Sketching . . . . .	4to,	5 00
Rideal's Sewage and the Bacterial Purification of Sewage. . . . .	8vo,	4 00
Riemer's Shaft-sinking under Difficult Conditions. (Corning and Peele.) .8vo,		3 00
Siebert and Biggin's Modern Stone-cutting and Masonry. . . . .	8vo,	1 50
Smith's Manual of Topographical Drawing. (McMillan.) . . . . .	8vo,	2 50
Soper's Air and Ventilation of Subways. (In Press.)		
Tracy's Plane Surveying . . . . .	16mo, mor.	3 00
* Trautwine's Civil Engineer's Pocket-book. . . . .	16mo, mor.	5 00
Venable's Garbage Crematories in America. . . . .	8vo,	2 00
Methods and Devices for Bacterial Treatment of Sewage. . . . .	8vo,	3 00
Wait's Engineering and Architectural Jurisprudence. . . . .	8vo,	6 00
Law of Contracts. . . . .	8vo,	3 00
Law of Operations Preliminary to Construction in Engineering and Archi- tecture. . . . .	8vo,	5 00
Sheep, . . . . .		5 50
Warren's Stereotomy—Problems in Stone-cutting. . . . .	8vo,	2 50
* Waterbury's Vest-Pocket Hand-book of Mathematics for Engineers.	2 $\frac{7}{8}$ $\times$ 5 $\frac{3}{8}$ inches, mor.	1 00
Webb's Problems in the Use and Adjustment of Engineering Instruments.	16mo, mor.	1 25
Wilson's Topographic Surveying. . . . .	8vo,	3 50

## BRIDGES AND ROOFS.

Boller's Practical Treatise on the Construction of Iron Highway Bridges. .8vo,		2 00
Burr and Falk's Design and Construction of Metallic Bridges . . . . .	8vo,	5 00
Influence Lines for Bridge and Roof Computations. . . . .	8vo,	3 00
Du Bois's Mechanics of Engineering. Vol. II. . . . .	Small 4to,	10 00
Foster's Treatise on Wooden Trestle Bridges. . . . .	4to,	5 00
Fowler's Ordinary Foundations . . . . .	8vo,	3 50
French and Ives's Stereotomy. . . . .	8vo,	2 50
Greene's Arches in Wood, Iron, and Stone. . . . .	8vo,	2 50
Bridge Trusses. . . . .	8vo,	2 50
Roof Trusses. . . . .	8vo,	1 25
Grimm's Secondary Stresses in Bridge Trusses. . . . .	8vo,	2 50
Heller's Stresses in Structures and the Accompanyin Deformations. . . . .	8vo,	
Howe's Design of Simple Roof-trusses in Wood and Steel. . . . .	8vo,	2 00
Symmetrical Masonry Arches. . . . .	8vo,	2 50
Treatise on Arches. . . . .	8vo,	4 00
Johnson, Bryan, and Turneure's Theory and Practice in the Designing of Modern Framed Structures. . . . .	Small 4to,	10 00



Merriman and Jacoby's Text-book on Roofs and Bridges:

Part I. Stresses in Simple Trusses.....	.8vo,	2 50
Part II. Graphic Statics.....	.8vo,	2 50
Part III. Bridge Design.....	.8vo,	2 50
Part IV. Higher Structures.....	.8vo,	2 50
Morison's Memphis Bridge.....	Oblong 4to,	10 00
Sondericker's Graphic Statics, with Applications to Trusses, Beams, and Arches.		
	.8vo,	2 00
Waddell's De Pontibus, Pocket-book for Bridge Engineers.....	16mo, mor,	2 00
* Specifications for Steel Bridges.....	12mo,	50
Waddell and Harrington's Bridge Engineering. (In Preparation.)		
Wright's Designing of Draw-spans. Two parts in one volume.....	.8vo,	3 50

HYDRAULICS.

Barnes's Ice Formation.....	.8vo,	3 00
Bazin's Experiments upon the Contraction of the Liquid Vein Issuing from an Orifice. (Trautwine.).....	.8vo,	2 00
Bovey's Treatise on Hydraulics.....	.8vo,	5 00
Church's Diagrams of Mean Velocity of Water in Open Channels.		
	Oblong 4to, paper,	1 50
Hydraulic Motors.....	.8vo,	2 00
Mechanics of Engineering.....	.8vo,	6 00
Coffin's Graphical Solution of Hydraulic Problems.....	16mo, morocco,	2 50
Fletcher's Dynamometers, and the Measurement of Power.....	12mo,	3 00
Folwell's Water-supply Engineering.....	.8vo,	4 00
Frizell's Water-power.....	.8vo,	5 00
Fuertes's Water and Public Health.....	12mo,	1 50
Water-filtration Works.....	12mo,	2 50
Ganguillet and Kutter's General Formula for the Uniform Flow of Water in Rivers and Other Channels. (Hering and Trautwine.).....	.8vo,	4 00
Hazen's Clean Water and How to Get It.....	Large 12mo,	1 50
Filtration of Public Water-supplies.....	.8vo,	3 00
Hazlehurst's Towers and Tanks for Water-works.....	.8vo,	2 50
Herschel's 115 Experiments on the Carrying Capacity of Large, Riveted, Metal Conduits.....	.8vo,	2 00
Hoyt and Grover's River Discharge.....	.8vo,	2 00
Hubbard and Kiersted's Water-works Management and Maintenance....	.8vo,	4 00
* Lyndon's Development and Electrical Distribution of Water Power....	.8vo,	3 00
Mason's Water-supply. (Considered Principally from a Sanitary Standpoint.)		
	.8vo,	4 00
Merriman's Treatise on Hydraulics.....	.8vo,	5 00
* Michie's Elements of Analytical Mechanics.....	.8vo,	4 00
Molitor's Hydraulics of Rivers, Weirs and Sluices. (In Press.)		
Schuyler's Reservoirs for Irrigation, Water-power, and Domestic Water-supply.....	Large 8vo,	5 00
* Thoma and Watt's Improvement of Rivers.....	4to,	6 00
Turneure and Russell's Public Water-supplies.....	.8vo,	5 00
Wegmann's Design and Construction of Dams. 5th Ed., enlarged.....	4to,	6 00
Water-supply of the City of New York from 1658 to 1895.....	4to,	10 00
Whipple's Value of Pure Water.....	Large 12mo,	1 00
Williams and Hazen's Hydraulic Tables.....	.8vo,	1 50
Wilson's Irrigation Engineering.....	Small 8vo,	4 00
Wolff's Windmill as a Prime Mover.....	.8vo,	3 00
Wood's Elements of Analytical Mechanics.....	.8vo,	3 00
Turbines.....	.8vo,	2 50

## MATERIALS OF ENGINEERING.

Baker's Roads and Pavements. . . . .	8vo,	5 00
Treatise on Masonry Construction. . . . .	8vo,	5 00
Birkmire's Architectural Iron and Steel. . . . .	8vo,	3 50
Compound Riveted Girders as Applied in Buildings. . . . .	8vo,	2 00
Black's United States Public Works . . . . .	Oblong 4to,	5 00
Bleining'er's Manufacture of Hydraulic Cement. (In Preparation.)		
* Bovey's Strength of Materials and Theory of Structures. . . . .	8vo,	7 50
Burr's Elasticity and Resistance of the Materials of Engineering. . . . .	8vo,	7 50
Byrne's Highway Construction. . . . .	8vo,	5 00
Inspection of the Materials and Workmanship Employed in Construction.	16mo,	3 00
Church's Mechanics of Engineering. . . . .	8vo,	6 00
Du Bois's Mechanics of Engineering.		
Vol. I. Kinematics, Statics, Kinetics. . . . .	Small 4to,	7 50
Vol. II. The Stresses in Framed Structures, Strength of Materials and Theory of Flexures. . . . .	Small 4to,	10 00
*Eckel's Cements, Limes, and Plasters. . . . .	8vo,	6 00
Stone and Clay Products used in Engineering. (In Preparation.)		
Fowler's Ordinary Foundations. . . . .	8vo,	3 50
Graves's Forest Mensuration. . . . .	8vo,	4 00
Green's Principles of American Forestry. . . . .	12mo,	1 50
* Greene's Structural Mechanics. . . . .	8vo,	2 50
Holly and Ladd's Analysis of Mixed Paints, Color Pigments and Varnishes	Large 12mo,	2 50
Johnson's Materials of Construction. . . . .	Large 8vo,	6 00
Keep's Cast Iron. . . . .	8vo,	2 50
Kidder's Architects and Builders' Pocket-book. . . . .	16mo,	5 00
Lanza's Applied Mechanics. . . . .	8vo,	7 50
Maire's Modern Pigments and their Vehicles . . . . .	12mo,	2 00
Martens's Handbook on Testing Materials. (Henning.) 2 vols. . . . .	8vo,	7 50
Maurer's Technical Mechanics. . . . .	8vo,	4 00
Merrill's Stones for Building and Decoration. . . . .	8vo,	5 00
Merriman's Mechanics of Materials. . . . .	8vo,	5 00
* Strength of Materials . . . . .	12mo,	1 00
Metcalf's Steel. A Manual for Steel-users. . . . .	12mo,	2 00
Patton's Practical Treatise on Foundations. . . . .	8vo,	5 00
Rice's Concrete Block Manufacture . . . . .	8vo,	2 00
Richardson's Modern Asphalt Pavements. . . . .	8vo,	3 00
Richey's Handbook for Superintendents of Construction. . . . .	16mo, mor.,	4 00
* Ries's Clays: Their Occurrence, Properties, and Uses. . . . .	8vo,	5 00
Sabin's Industrial and Artistic Technology of Paints and Varnish. . . . .	8vo,	3 00
* Schwarz's Longleaf Pine in Virgin Forest. . . . .	12mo,	1 25
Snow's Principal Species of Wood. . . . .	8vo,	3 50
Spalding's Hydraulic Cement. . . . .	12mo,	2 00
Text-book on Roads and Pavements. . . . .	12mo,	2 00
Taylor and Thompson's Treatise on Concrete, Plain and Reinforced. . . . .	8vo,	5 00
Thurston's Materials of Engineering. In Three Parts. . . . .	8vo,	8 00
Part I. Non-metallic Materials of Engineering and Metallurgy. . . . .	8vo,	2 00
Part II. Iron and Steel. . . . .	8vo,	3 50
Part III. A Treatise on Brasses, Bronzes, and Other Alloys and their Constituents. . . . .	8vo,	2 50
Tillson's Street Pavements and Paving Materials. . . . .	8vo,	4 00
Turneure and Maurer's Principles of Reinforced Concrete Construction. . . . .	8vo,	3 00
Wood's (De V.) Treatise on the Resistance of Materials, and an Appendix on the Preservation of Timber. . . . .	8vo,	2 00
Wood's (M. P.) Rustless Coatings: Corrosion and Electrolysis of Iron and Steel. . . . .	8vo,	4 00



## RAILWAY ENGINEERING.

Andrews's Handbook for Street Railway Engineers.....	3x5 inches, mor.	1 25
Berg's Buildings and Structures of American Railroads.....	4to,	5 00
Brooks's Handbook of Street Railroad Location.....	16mo, mor.	1 50
Butt's Civil Engineer's Field-book.....	16mo, mor.	2 50
Crandall's Railway and Other Earthwork Tables.....	8vo,	1 50
Transition Curve.....	16mo, mor.	1 50
* Crockett's Methods for Earthwork Computations.....	8vo,	1 50
Dawson's "Engineering" and Electric Traction Pocket-book.....	16mo, mor.	5 00
Dredge's History of the Pennsylvania Railroad: (1879).....	Paper,	5 00
Fisher's Table of Cubic Yards.....	Cardboard,	25
Godwin's Railroad Engineers' Field-book and Explorers' Guide... ..	16mo, mor.	2 50
Hudson's Tables for Calculating the Cubic Contents of Excavations and Embankments.....	8vo,	1 00
Ives and Hilts's Problems in Surveying, Railroad Surveying and Geodesy.....	16mo, mor.	1 50
Molitor and Beard's Manual for Resident Engineers.....	16mo,	1 00
Nagle's Field Manual for Railroad Engineers.....	16mo, mor.	3 00
Philbrick's Field Manual for Engineers.....	16mo, mor.	3 00
Raymond's Railroad Engineering. 3 volumes.		
Vol. I. Railroad Field Geometry. (In Preparation.)		
Vol. II. Elements of Railroad Engineering.....	8vo,	3 50
Vol III. Railroad Engineer's Field Book. (In Preparation.)		
Searles's Field Engineering.....	16mo, mor.	3 00
Railroad Spiral.....	16mo, mor.	1 50
Taylor's Prismatical Formulæ and Earthwork.....	8vo,	1 50
* Trautwine's Field Practice of Laying Out Circular Curves for Railroads.....	12mo, mor,	2 50
* Method of Calculating the Cubic Contents of Excavations and Embankments by the Aid of Diagrams.....	8vo,	2 00
Webb's Economics of Railroad Construction.....	Large 12mo,	2 50
Railroad Construction.....	16mo, mor.	5 00
Wellington's Economic Theory of the Location of Railways.....	Small 8vo,	5 00

## DRAWING.

Barr's Kinematics of Machinery.....	8vo,	2 50
* Bartlett's Mechanical Drawing.....	8vo,	3 00
* " " " " Abridged Ed.....	8vo,	1 50
Coolidge's Manual of Drawing.....	8vo, paper,	1 00
Coolidge and Freeman's Elements of General Drafting for Mechanical Engineers.....	Oblong 4to,	2 50
Durley's Kinematics of Machines.....	8vo,	4 00
Emch's Introduction to Projective Geometry and its Applications.....	8vo,	2 50
Hill's Text-book on Shades and Shadows, and Perspective.....	8vo,	2 00
Jamison's Advanced Mechanical Drawing.....	8vo,	2 00
Elements of Mechanical Drawing.....	8vo,	2 50
Jones's Machine Design:		
Part I. Kinematics of Machinery.....	8vo,	1 50
Part II. Form, Strength, and Proportions of Parts.....	8vo,	3 00
MacCord's Elements of Descriptive Geometry.....	8vo,	3 00
Kinematics; or, Practical Mechanism.....	8vo,	5 00
Mechanical Drawing.....	4to,	4 00
Velocity Diagrams.....	8vo,	1 50
McLeod's Descriptive Geometry.....	Large 12mo,	1 50
* Mahan's Descriptive Geometry and Stone-cutting.....	8vo,	1 50
Industrial Drawing. (Thompson.).....	8vo,	3 50

Moyer's Descriptive Geometry.....	8vo,	2 00
Reed's Topographical Drawing and Sketching.....	4to,	5 00
Reid's Course in Mechanical Drawing.....	8vo,	2 00
Text-book of Mechanical Drawing and Elementary Machine Design.....	8vo,	3 00
Robinson's Principles of Mechanism.....	8vo,	3 00
Schwamb and Merrill's Elements of Mechanism.....	8vo,	3 00
Smith's (R. S.) Manual of Topographical Drawing. (McMillan.).....	8vo,	2 50
Smith (A. W.) and Marx's Machine Design.....	8vo,	3 00
* Titsworth's Elements of Mechanical Drawing.....	Oblong 8vo,	1 25
* Warren's Drafting Instruments and Operations.....	12mo,	1 25
Elements of Descriptive Geometry, Shadows, and Perspective.....	8vo,	3 50
Elements of Machine Construction and Drawing.....	8vo,	7 50
Elements of Plane and Solid Free-hand Geometrical Drawing.....	1 2mo,	1 00
General Problems of Shades and Shadows.....	8vo,	3 00
Manual of Elementary Problems in the Linear Perspective of Form and Shadow.....	12mo,	1 00
Manual of Elementary Projection Drawing.....	12mo,	1 50
Plane Problems in Elementary Geometry.....	12mo,	1 25
Problems, Theorems, and Examples in Descriptive Geometry.....	8vo,	2 50
Weisbach's Kinematics and Power of Transmission. (Hermann and Klein.).....	8vo,	5 00
Wilson's (H. M.) Topographic Surveying.....	8vo,	3 50
Wilson's (V. T.) Free-hand Lettering.....	8vo,	1 00
Free-hand Perspective.....	8vo,	2 50
Woolf's Elementary Course in Descriptive Geometry.....	Large 8vo,	3 00

## ELECTRICITY AND PHYSICS.

* Abegg's Theory of Electrolytic Dissociation. (von Ende.).....	12mo,	1 25
Andrews's Hand-Book for Street Railway Engineering.....	3×5 inches, mor.,	1 25
Anthony and Brackett's Text-book of Physics. (Magie.).....	Large 12mo,	3 00
Anthony's Lecture-notes on the Theory of Electrical Measurements.....	12mo,	1 00
Benjamin's History of Electricity.....	8vo,	3 00
Voltaic Cell.....	8vo,	3 00
Betts's Lead Refining and Electrolysis.....	8vo,	4 00
Classen's Quantitative Chemical Analysis by Electrolysis. (Boltwood.).....	8vo,	3 00
* Collins's Manual of Wireless Telegraphy.....	12mo,	1 50
	Mor.	2 00
Crehore and Squier's Polarizing Photo-chronograph.....	8vo,	3 00
* Danneel's Electrochemistry. (Merriam.).....	12mo,	1 25
Dawson's "Engineering" and Electric Traction Pocket-book.....	16mo, mor	5 00
Dolezalek's Theory of the Lead Accumulator (Storage Battery). (von Ende.).....	12mo,	2 50
Duhem's Thermodynamics and Chemistry. (Burgess.).....	8vo,	4 00
Flather's Dynamometers, and the Measurement of Power.....	12mo,	3 00
Gilbert's De Magnete. (Mottelay.).....	8vo,	2 50
* Hanchett's Alternating Currents.....	12mo,	1 00
Hering's Ready Reference Tables (Conversion Factors).....	16mo, mor.	2 50
Hobart and Ellis's High-speed Dynamo Electric Machinery. (In Press.).....		
Holman's Precision of Measurements.....	8vo,	2 00
Telescopic Mirror-scale Method, Adjustments, and Tests.....	Large 8vo,	75
* Karapetoff's Experimental Electrical Engineering.....	8vo,	6 00
Kinzbrunner's Testing of Continuous-current Machines.....	8vo,	2 00
Landauer's Spectrum Analysis. (Tingle.).....	8vo,	3 00
Le Chatelier's High-temperature Measurements. (Boudouard—Burgess.).....	12mo,	3 00
Löb's Electrochemistry of Organic Compounds. (Lorenz.).....	8vo,	3 00
* Lyndon's Development and Electrical Distribution of Water Power.....	8vo,	3 00
* Lyons's Treatise on Electromagnetic Phenomena. Vols. I. and II. 8vo, each.....		6 00
* Michie's Elements of Wave Motion Relating to Sound and Light.....	8vo,	4 00

Morgan's Outline of the Theory of Solution and its Results.....	12mo,	1 00
* Physical Chemistry for Electrical Engineers.....	12mo,	1 50
Niaudet's Elementary Treatise on Electric Batteries. (Fishback)....	12mo.	2 50
* Norris's Introduction to the Study of Electrical Engineering.....	8vo,	2 50
* Parshall and Hobart's Electric Machine Design.....	4to, half morocco,	12 50
Reagan's Locomotives: Simple, Compound, and Electric. New Edition.		
	Large 12mo,	3 50
* Rosenberg's Electrical Engineering. (Haldane Gee—Kinzbrunner.)..	8vo,	2 00
Ryan, Norris, and Hoxie's Electrical Machinery. Vol. I.....	8vo,	2 50
Schapper's Laboratory Guide for Students in Physical Chemistry.....	12mo,	1 00
Thurston's Stationary Steam-engines.....	8vo,	2 50
* Tillman's Elementary Lessons in Heat.....	8vo,	1 50
Tory and Pitcher's Manual of Laboratory Physics.....	Large 12mo,	2 00
Ulke's Modern Electrolytic Copper Refining.....	8vo,	3 00

## LAW.

* Davis's Elements of Law.....	8vo,	2 50
* Treatise on the Military Law of United States.....	8vo,	7 00
*	Sheep,	7 50
* Dudley's Military Law and the Procedure of Courts-martial....	Large 12mo,	2 50
Manual for Courts-martial.....	16mo, mor.	1 50
Wait's Engineering and Architectural Jurisprudence.....	8vo,	6 00
	Sheep,	6 50
Law of Contracts.....	8vo,	3 00
Law of Operations Preliminary to Construction in Engineering and Architecture.....	8vo	5 00
	Sheep,	5 50

## MATHEMATICS.

Baker's Elliptic Functions.....	8vo,	1 50
Briggs's Elements of Plane Analytic Geometry. (Bôcher).....	12mo,	1 00
* Buchanan's Plane and Spherical Trigonometry.....	8vo,	1 00
Byerley's Harmonic Functions.....	8vo,	1 00
Chandler's Elements of the Infinitesimal Calculus.....	12mo,	2 00
Compton's Manual of Logarithmic Computations.....	12mo,	1 50
Davis's Introduction to the Logic of Algebra.....	8vo,	1 50
* Dickson's College Algebra.....	Large 12mo,	1 50
* Introduction to the Theory of Algebraic Equations.....	Large 12mo,	1 25
Emch's Introduction to Projective Geometry and its Applications.....	8vo,	2 50
Fiske's Functions of a Complex Variable.....	8vo,	1 00
Halsted's Elementary Synthetic Geometry.....	8vo,	1 50
Elements of Geometry.....	8vo,	1 75
* Rational Geometry.....	12mo,	1 50
Hyde's Grassmann's Space Analysis.....	8vo,	1 00
* Jonnson's (J. B.) Three-place Logarithmic Tables: Vest-pocket size, paper,		15
	100 copies,	5 00
*	Mounted on heavy cardboard, 8×10 inches,	25
	10 copies,	2 00
Johnson's (W. W.) Abridged Editions of Differential and Integral Calculus		
	Large 12mo, 1 vol.	2 50
Curve Tracing in Cartesian Co-ordinates.....	12mo,	1 00
Differential Equations.....	8vo,	1 00
Elementary Treatise on Differential Calculus. (In Press.)		
Elementary Treatise on the Integral Calculus.....	Large 12mo,	1 50
* Theoretical Mechanics.....	12mo,	3 00
Theory of Errors and the Method of Least Squares.....	12mo,	1 50
Treatise on Differential Calculus.....	Large 12mo,	3 00
Treatise on the Integral Calculus.....	Large 12mo,	3 00
Treatise on Ordinary and Partial Differential Equations..	Large 12mo,	3 50



Laplace's Philosophical Essay on Probabilities. (Truscott and Emory).	12mo,	2 00
* Ludlow and Bass's Elements of Trigonometry and Logarithmic and Other Tables . . . . .	8vo,	3 00
Trigonometry and Tables published separately . . . . .	Each,	2 00
* Ludlow's Logarithmic and Trigonometric Tables . . . . .	8vo,	1 00
Macfarlane's Vector Analysis and Quaternions . . . . .	8vo,	1 00
McMahon's Hyperbolic Functions . . . . .	8vo,	1 00
Manning's Irrational Numbers and their Representation by Sequences and Series	12mo,	1 25
Mathematical Monographs. Edited by Mansfield Merriman and Robert S. Woodward. . . . .	Octavo, each	1 00
No. 1. History of Modern Mathematics, by David Eugene Smith.		
No. 2. Synthetic Projective Geometry, by George Bruce Halsted.		
No. 3. Determinants, by Laenas Gifford Weld. No. 4. Hyperbolic Functions, by James McMahon. No. 5. Harmonic Functions, by William E. Byerly. No. 6. Grassmann's Space Analysis, by Edward W. Hyde. No. 7. Probability and Theory of Errors, by Robert S. Woodward. No. 8. Vector Analysis and Quaternions, by Alexander Macfarlane. No. 9. Differential Equations, by William Woolsey Johnson. No. 10. The Solution of Equations, by Mansfield Merriman. No. 11. Functions of a Complex Variable, by Thomas S. Fiske.		
Maurer's Technical Mechanics. . . . .	8vo,	4 00
Merriman's Method of Least Squares. . . . .	8vo,	2 00
Solution of Equations . . . . .	8vo,	1 00
Rice and Johnson's Differential and Integral Calculus. 2 vols. in one.		
Large 12mo,	1 50	
Elementary Treatise on the Differential Calculus. . . . .	Large 12mo,	3 00
Smith's History of Modern Mathematics . . . . .	8vo,	1 00
* Veblen and Lennes's Introduction to the Real Infinitesimal Analysis of One Variable . . . . .	8vo,	2 00
* Waterbury's Vest Pocket Hand-Book of Mathematics for Engineers.		
2 $\frac{1}{8}$ $\times$ 5 $\frac{3}{8}$ inches, mor.,	1 00	
Weld's Determinations. . . . .	8vo,	1 00
Wood's Elements of Co-ordinate Geometry. . . . .	8vo,	2 00
Woodward's Probability and Theory of Errors. . . . .	8vo,	1 00

## MECHANICAL ENGINEERING.

### MATERIALS OF ENGINEERING, STEAM-ENGINES AND BOILERS.

Bacon's Forge Practice. . . . .	12mo,	1 50
Baldwin's Steam Heating for Buildings. . . . .	12mo,	2 50
Bair's Kinematics of Machinery. . . . .	8vo,	2 50
* Bartlett's Mechanical Drawing. . . . .	8vo,	3 00
* " " " Abridged Ed. . . . .	8vo,	1 50
Benjamin's Wrinkles and Recipes. . . . .	12mo,	2 00
* Burr's Ancient and Modern Engineering and the Isthmian Canal. . . . .	8vo,	3 50
Carpenter's Experimental Engineering. . . . .	8vo,	6 00
Heating and Ventilating Buildings. . . . .	8vo,	4 00
Clerk's Gas and Oil Engine. . . . .	Large 12mo,	4 00
Compton's First Lessons in Metal Working . . . . .	12mo,	1 50
Compton and De Groodt's Speed Lathe. . . . .	12mo,	1 50
Coolidge's Manual of Drawing. . . . .	8vo, paper,	1 00
Coolidge and Freeman's Elements of General Drafting for Mechanical Engineers. . . . .	Oblong 4to,	2 50
Cromwell's Treatise on Belts and Pulleys. . . . .	12mo,	1 50
Treatise on Toothed Gearing. . . . .	12mo,	1 50
Durley's Kinematics of Machines. . . . .	8vo,	4 00

Flather's Dynamometers and the Measurement of Power. . . . .	12mo,	3 00
Rope Driving. . . . .	12mo,	2 00
Gill's Gas and Fuel Analysis for Engineers. . . . .	12mo,	1 25
Goss's Locomotive Sparks. . . . .	8vo,	2 00
Hall's Car Lubrication. . . . .	12mo,	1 00
Hering's Ready Reference Tables (Conversion Factors). . . . .	16mo, mor.,	2 50
Hobart and Elis's High Speed Dynamo Electric Machinery. (In Press.)		
Hutton's Gas Engine. . . . .	8vo,	5 00
Jamison's Advanced Mechanical Drawing. . . . .	8vo,	2 00
Elements of Mechanical Drawing. . . . .	8vo,	2 50
Jones's Machine Design:		
Part I. Kinematics of Machinery. . . . .	8vo,	1 50
Part II. Form, Strength, and Proportions of Parts. . . . .	8vo,	3 00
Kent's Mechanical Engineers' Pocket-book. . . . .	16mo, mor,	5 00
Kerr's Power and Power Transmission. . . . .	8vo,	2 00
Leonard's Machine Shop Tools and Methods . . . . .	8vo,	4 00
* Lorenz's Modern Refrigerating Machinery. (Pope, Haven, and Dean.) . . . .	8vo,	4 00
MacCord's Kinematics; or, Practical Mechanism. . . . .	8vo,	5 00
Mechanical Drawing. . . . .	4to,	4 00
Velocity Diagrams. . . . .	8vo,	1 50
MacFarland's Standard Reduction Factors for Gases. . . . .	8vo,	1 50
Mahan's Industrial Drawing. (Thompson.) . . . . .	8vo,	3 50
* Parshall and Hobart's Electric Machine Design. . . . .	Small 4to, half leather,	12 50
Peele's Compressed Air Plant for Mines. (In Press.)		
Poole's Calorific Power of Fuels. . . . .	8vo,	3 00
* Porter's Engineering Reminiscences, 1855 to 1882. . . . .	8vo,	3 00
Reid's Course in Mechanical Drawing. . . . .	8vo,	2 00
Text-book of Mechanical Drawing and Elementary Machine Design. . . . .	8vo,	3 00
Richard's Compressed Air . . . . .	12mo,	1 50
Robinson's Principles of Mechanism. . . . .	8vo,	3 00
Schwamb and Merrill's Elements of Mechanism. . . . .	8vo,	3 00
Smith's (O.) Press-working of Metals. . . . .	8vo,	3 00
Smith (A. W.) and Marx's Machine Design. . . . .	8vo,	3 00
Sorel's Carbureting and Combustion in Alcohol Engines. (Woodward and Preston).	Large 12mo,	3 00
Thurston's Animal as a Machine and Prime Motor, and the Laws of Energetics.	12mo,	1 00
Treatise on Friction and Lost Work in Machinery and Mill Work. . . . .	8vo,	3 00
Tillson's Complete Automobile Instructor . . . . .	16mo,	1 50
	mor.,	2 00
* Titsworth's Elements of Mechanical Drawing. . . . .	Oblong 8vo,	1 25
Warren's Elements of Machine Construction and Drawing. . . . .	8vo,	7 50
* Waterbury's Vest Pocket Hand Book of Mathematics for Engineers.	2 $\frac{7}{8}$ $\times$ 5 $\frac{1}{2}$ inches, mor.,	1 00
Weisbach's Kinematics and the Power of Transmission. (Herrmann—Klein.) . . . . .	8vo,	5 00
Machinery of Transmission and Governors. (Herrmann—Klein.) . . . . .	8vo,	5 00
Wolff's Windmill as a Prime Mover. . . . .	8vo,	3 00
Wood's Turbines. . . . .	8vo,	2 50

## MATERIALS OF ENGINEERING.

* Bovey's Strength of Materials and Theory of Structures. . . . .	8vo,	7 50
Burr's Elasticity and Resistance of the Materials of Engineering. . . . .	8vo,	7 50
Church's Mechanics of Engineering. . . . .	8vo,	6 00
* Greene's Structural Mechanics . . . . .	8vo,	2 50
Holley and Ladd's Analysis of Mixed Paints, Color Pigments, and Varnishes.	Large 12mo,	2 50
Johnson's Materials of Construction. . . . .	8vo,	6 00
Keep's Cast Iron. . . . .	8vo,	2 50
Lanza's Applied Mechanics. . . . .	8vo,	7 50



Maire's Modern Pigments and their Vehicles.....	12mo,	2 00
Martens's Handbook on Testing Materials. (Henning.).....	8vo,	7 50
Maurer's Technical Mechanics. ....	8vo,	4 00
Merriman's Mechanics of Materials.....	8vo,	5 00
* Strength of Materials.....	12mo,	1 00
Metcalf's Steel. A Manual for Steel-users.....	12mo,	2 00
Sabin's Industrial and Artistic Technology of Paints and Varnish.....	8vo,	3 00
Smith's Materials of Machines.....	12mo,	1 00
Thurston's Materials of Engineering.....	3 vols.,	8vo, 8 00
Part I. Non-metallic Materials of Engineering, see Civil Engineering, page 9.		
Part II. Iron and Steel.....	8vo,	3 50
Part III. A Treatise on Brasses, Bronzes, and Other Alloys and their Constituents.....	8vo,	2 50
Wood's (De V.) Elements of Analytical Mechanics.....	8vo,	3 00
Treatise on the Resistance of Materials and an Appendix on the Preservation of Timber.....	8vo,	2 00
Wood's (M. P.) Rustless Coatings: Corrosion and Electrolysis of Iron and Steel.....	8vo,	4 00

## STEAM-ENGINES AND BOILERS.

Berry's Temperature-entropy Diagram.....	12mo,	1 25
Carnot's Reflections on the Motive Power of Heat. (Thurston.).....	12mo,	1 50
Chase's Art of Pattern Making.....	12mo,	2 50
Creighton's Steam-engine and other Heat-motors.....	8vo,	5 00
Dawson's "Engineering" and Electric Traction Pocket-book.....	16mo, mor.,	5 00
Ford's Boiler Making for Boiler Makers.....	18mo,	1 00
Goss's Locomotive Performance.....	8vo,	5 00
Hemenway's Indicator Practice and Steam-engine Economy.....	12mo,	2 00
Hutton's Heat and Heat-engines.....	8vo,	5 00
Mechanical Engineering of Power Plants.....	8vo,	5 00
Kent's Steam boiler Economy.....	8vo,	4 00
Kneass's Practice and Theory of the Injector.....	8vo,	1 50
MacCord's Slide-valves.....	8vo,	2 00
Meyer's Modern Locomotive Construction.....	4to,	10 00
Moyer's Steam Turbines. (In Press.)		
Peabody's Manual of the Steam-engine Indicator.....	12mo,	1 50
Tables of the Properties of Saturated Steam and Other Vapors.....	8vo,	1 00
Thermodynamics of the Steam-engine and Other Heat-engines.....	8vo,	5 00
Valve-gears for Steam-engines.....	8vo,	2 50
Peabody and Miller's Steam-boilers.....	8vo,	4 00
Pray's Twenty Years with the Indicator.....	Large 8vo,	2 50
Pupin's Thermodynamics of Reversible Cycles in Gases and Saturated Vapors. (Osterberg.).....	12mo,	1 25
Reagan's Locomotives: Simple, Compound, and Electric. New Edition. Large	12mo,	3 50
Sinclair's Locomotive Engine Running and Management.....	12mo,	2 00
Smart's Handbook of Engineering Laboratory Practice.....	12mo,	2 50
Snow's Steam-boiler Practice.....	8vo,	3 00
Spangler's Notes on Thermodynamics.....	12mo,	1 00
Valve-gears.....	8vo,	2 50
Spangler, Greene, and Marshall's Elements of Steam-engineering.....	8vo,	3 00
Thomas's Steam-turbines.....	8vo,	4 00
Thurston's Handbook of Engine and Boiler Trials, and the Use of the Indi- cator and the Prony Brake.....	8vo,	5 00
Handy Tables.....	8vo,	1 50
Manual of Steam-boilers, their Designs, Construction, and Operation.....	8vo,	5 00

Thurston's Manual of the Steam-engine.....	2 vols., 8vo,	10 00
Part I. History, Structure, and Theory.....	8vo,	6 00
Part II. Design, Construction, and Operation.....	8vo,	6 00
Stationary Steam-engines.....	8vo,	2 50
Steam-boiler Explosions in Theory and in Practice.....	12mo,	1 50
Wehrenfenning's Analysis and Softening of Boiler Feed-water (Patterson)	8vo,	4 00
Weisbach's Heat, Steam, and Steam-engines. (Du Bois.).....	8vo,	5 00
Whitham's Steam-engine Design.....	8vo,	5 00
Wood's Thermodynamics, Heat Motors, and Refrigerating Machines.....	8vo,	4 00

## MECHANICS PURE AND APPLIED.

Church's Mechanics of Engineering.....	8vo,	6 00
Notes and Examples in Mechanics.....	8vo,	2 00
Dana's Text-book of Elementary Mechanics for Colleges and Schools.....	12mo,	1 50
Du Bois's Elementary Principles of Mechanics:		
Vol. I. Kinematics.....	8vo,	3 50
Vol. II. Statics.....	8vo,	4 00
Mechanics of Engineering. Vol. I.....	Small 4to,	7 50
Vol. II.....	Small 4to,	10 00
* Greene's Structural Mechanics.....	8vo,	2 50
James's Kinematics of a Point and the Rational Mechanics of a Particle.....	Large 12mo,	2 00
* Johnson's (W. W.) Theoretical Mechanics.....	12mo,	3 00
Lanza's Applied Mechanics.....	8vo,	7 50
* Martin's Text Book on Mechanics, Vol. I, Statics.....	12mo,	1 25
* Vol. 2, Kinematics and Kinetics.....	12mo,	1 50
Maurer's Technical Mechanics.....	8vo,	4 00
* Merriman's Elements of Mechanics.....	12mo,	1 00
Mechanics of Materials.....	8vo,	5 00
* Michie's Elements of Analytical Mechanics.....	8vo,	4 00
Robinson's Principles of Mechanism.....	8vo,	3 00
Sanborn's Mechanics Problems.....	Large 12mo,	1 50
Schwamb and Merrill's Elements of Mechanism.....	8vo,	3 00
Wood's Elements of Analytical Mechanics.....	8vo,	3 00
Principles of Elementary Mechanics.....	12mo,	1 25

## MEDICAL.

Abderhalden's Physiological Chemistry in Thirty Lectures. (Hall and Defren). (In Press).		
von Behring's Suppression of Tuberculosis. (Bolduan.).....	12mo,	1 00
* Bolduan's Immune Sera.....	12mo,	1 50
Davenport's Statistical Methods with Special Reference to Biological Variations.....	16mo, mor.,	1 50
Ehrlich's Collected Studies on Immunity. (Bolduan.).....	8vo,	6 00
* Fischer's Physiology of Alimentation.....	Large 12mo, cloth,	2 00
de Fursac's Manual of Psychiatry. (Rosanoff and Collins.).....	Large 12mo,	2 50
Hammarsten's Text-book on Physiological Chemistry. (Mandel.).....	8vo,	4 00
Jackson's Directions for Laboratory Work in Physiological Chemistry.....	8vo,	1 25
Lassar-Cohn's Practical Urinary Analysis. (Lorenz.).....	12mo,	1 00
Mandel's Hand Book for the Bio-Chemical Laboratory.....	12mo,	1 50
* Pauli's Physical Chemistry in the Service of Medicine. (Fischer.).....	12mo,	1 25
* Pozzi-Escot's Toxins and Venoms and their Antibodies. (Cohn.).....	12mo,	1 00
Rostoski's Serum Diagnosis. (Bolduan.).....	12mo,	1 00
Ruddiman's Incompatibilities in Prescriptions.....	8vo,	2 00
Whys in Pharmacy.....	12mo,	1 00
Salkowski's Physiological and Pathological Chemistry. (Orndorff.).....	8vo,	2 50
* Satterlee's Outlines of Human Embryology.....	12mo,	1 25
Smith's Lecture Notes on Chemistry for Dental Students.....	8vo,	2 50

Steel's Treatise on the Diseases of the Dog. ....	8vo,	3 50
* Whipple's Typhoid Fever. ....	Large 12mo,	3 00
Woodhull's Notes on Military Hygiene. ....	16mo,	1 50
* Personal Hygiene. ....	12mo,	1 00
Worcester and Atkinson's Small Hospitals Establishment and Maintenance, and Suggestions for Hospital Architecture, with Plans for a Small Hospital. ....	12mo,	1 25

## METALLURGY.

Betts's Lead Refining by Electrolysis. ....	8vo.	4 00
Bolland's Encyclopedia of Founding and Dictionary of Foundry Terms Used in the Practice of Moulding. ....	12mo,	3 00
Iron Founder. ....	12mo.	2 50
"    "    Supplement. ....	12mo,	2 50
Douglas's Untechnical Addresses on Technical Subjects. ....	12mo,	1 00
Goesel's Minerals and Metals: A Reference Book. ....	16mo, mor.	3 00
* Iles's Lead-smelting. ....	12mo,	2 50
Keep's Cast Iron. ....	8vo,	2 50
Le Chatelier's High-temperature Measurements. (Boudouard—Burgess.)	12mo,	3 00
Metcalf's Steel. A Manual for Steel-users. ....	12mo,	2 00
Miller's Cyanide Process. ....	12mo	1 00
Minet's Production of Aluminum and its Industrial Use. (Waldo.)	12mo,	2 50
Robine and Lenglen's Cyanide Industry. (Le Clerc.)	8vo,	4 00
Ruer's Elements of Metallurgy. (Mathewson). (In Press.)		
Smith's Materials of Machines. ....	12mo,	1 00
Thurston's Materials of Engineering. In Three Parts. ....	8vo,	8 00
part I. Non-metallic Materials of Engineering, see Civil Engineering, page 9.		
Part II. Iron and Steel. ....	8vo,	3 50
Part III. A Treatise on Brasses, Bronzes, and Other Alloys and their Constituents. ....	8vo,	2 50
Ulke's Modern Electrolytic Copper Refining. ....	8vo,	3 00
West's American Foundry Practice. ....	12mo,	2 50
Moulders Text Book. ....	12mo,	2 50
Wilson's Chlorination Process. ....	12mo,	1 50
Cyanide Processes. ....	12mo,	1 50

## MINERALOGY.

Barringer's Description of Minerals of Commercial Value. Oblong, morocco,	2 50
Boyd's Resources of Southwest Virginia. ....	8vo 3 00
Boyd's Map of Southwest Virginia. ....	Pocket-book form. 2 00
* Browning's Introduction to the Rarer Elements. ....	8vo, 1 50
Brush's Manual of Determinative Mineralogy. (Penfield.)	8vo, 4 00
Butler's Pocket Hand-Book of Minerals. ....	16mo, mor. 3 00
Chester's Catalogue of Minerals. ....	8vo, paper, 1 00
	Cloth, 1 25
Crane's Gold and Silver. (In Press.)	
Dana's First Appendix to Dana's New "System of Mineralogy."	Large 8vo, 1 00
Manual of Mineralogy and Petrography. ....	12mo 2 00
Minerals and How to Study Them. ....	12mo, 1 50
System of Mineralogy. ....	Large 8vo, half leather, 12 50
Text-book of Mineralogy. ....	8vo, 4 00
Douglas's Untechnical Addresses on Technical Subjects. ....	12mo, 1 00
Eakle's Mineral Tables. ....	8vo, 1 25
Stone and Clay Products Used in Engineering. (In Preparation).	
Egleston's Catalogue of Minerals and Synonyms. ....	8vo, 2 50
Goesel's Minerals and Metals: A Reference Book. ....	16mo, mor. 3 00
Groth's Introduction to Chemical Crystallography (Marshall)	12mo, 1 25



* Iddings's Rock Minerals.....	8vo,	5 00
Johannsen's Determination of Rock-forming Minerals in Thin Sections....	8vo,	4 00
* Martin's Laboratory Guide to Qualitative Analysis with the Blowpipe.....	12mo,	60
Merrill's Non-metallic Minerals: Their Occurrence and Uses.....	8vo,	4 00
Stones for Building and Decoration.....	8vo,	5 00
* Penfield's Notes on Determinative Mineralogy and Record of Mineral Tests.	8vo, paper,	50
Tables of Minerals, Including the Use of Minerals and Statistics of Domestic Production.....	8vo,	1 00
Pirsson's Rocks and Rock Minerals. (In Press.)		
* Richards's Synopsis of Mineral Characters.....	12mo, mor.	1 25
* Ries's Clays: Their Occurrence, Properties, and Uses.....	8vo,	5 00
* Tillman's Text-book of Important Minerals and Rocks.....	8vo,	2 00

## MINING.

* Beard's Mine Gases and Explosions.....	Large 12mo,	3 00
Boyd's Map of Southwest Virginia.....	Pocket-book form,	2 00
Resources of Southwest Virginia.....	8vo,	3 00
Crane's Gold and Silver. (In Press.)		
Douglas's Untechnical Addresses on Technical Subjects.....	12mo,	1 00
Eissler's Modern High Explosives.....	8vo,	4 00
Goessel's Minerals and Metals: A Reference Book.....	16mo, mor.	3 00
Ihlseng's Manual of Mining.....	8vo,	5 00
* Iles's Lead-smelting.....	12mo,	2 50
Miller's Cyanide Process.....	12mo,	1 00
O'Driscoll's Notes on the Treatment of Gold Ores.....	8vo,	2 00
Peele's Compressed Air Plant for Mines. (In Press.)		
Riemer's Shaft Sinking Under Difficult Conditions. (Corning and Peele)...	8vo,	3 00
Robine and Lenglen's Cyanide Industry. (Le Clerc.).....	8vo,	4 00
* Weaver's Military Explosives.....	8vo,	3 00
Wilson's Chlorination Process.....	12mo,	1 50
Cyanide Processes.....	12mo,	1 50
Hydraulic and Placer Mining. 2d edition, rewritten.....	12mo,	2 50
Treatise on Practical and Theoretical Mine Ventilation.....	12mo,	1 25

## SANITARY SCIENCE.

Association of State and National Food and Dairy Departments, Hartford Meeting, 1906.....	8vo,	3 00
Jamestown Meeting, 1907.....	8vo,	3 00
* Bashore's Outlines of Practical Sanitation.....	12mo,	1 25
Sanitation of a Country House.....	12mo,	1 00
Sanitation of Recreation Camps and Parks.....	12mo,	1 00
Folwell's Sewerage. (Designing, Construction, and Maintenance.)....	8vo,	3 00
Water-supply Engineering.....	8vo,	4 00
Fowler's Sewage Works Analyses.....	12mo,	2 00
Fuertes's Water-filtration Works.....	12mo,	2 50
Water and Public Health.....	12mo,	1 50
Gerhard's Guide to Sanitary House-inspection.....	16mo,	1 00
* Modern Baths and Bath Houses.....	8vo,	3 00
Sanitation of Public Buildings.....	12mo,	1 50
Hazen's Clean Water and How to Get It.....	Large 12mo,	1 50
Filtration of Public Water-supplies.....	8vo,	3 00
Kinnicut, Winslow and Pratt's Purification of Sewage. (In Press.)		
Leach's Inspection and Analysis of Food with Special Reference to State Control.....	8vo,	7 00
Mason's Examination of Water. (Chemical and Bacteriological)....	12mo,	1 25
Water-supply. (Considered principally from a Sanitary Standpoint)....	8vo,	4 00



* Merriman's Elements of Sanitary Engineering.....	8vo,	2 00
Ogden's Sewer Design.....	12mo,	2 00
Parsons's Disposal of Municipal Refuse.....	8vo,	2 00
Prescott and Winslow's Elements of Water Bacteriology, with Special Reference to Sanitary Water Analysis.....	12mo,	1 50
* Price's Handbook on Sanitation.....	12mo,	1 50
Richards's Cost of Food. A Study in Dietaries.....	12mo,	1 00
Cost of Living as Modified by Sanitary Science.....	12mo,	1 00
Cost of Shelter.....	12mo,	1 00
* Richards and Williams's Dietary Computer.....	8vo,	1 50
Richards and Woodman's Air, Water, and Food from a Sanitary Standpoint.....	8vo,	2 00
Rideal's Disinfection and the Preservation of Food.....	8vo,	4 00
Sewage and Bacterial Purification of Sewage.....	8vo,	4 00
Soper's Air and Ventilation of Subways. (In Press.)		
Turneure and Russell's Public Water-supplies.....	8vo,	5 00
Venable's Garbage Crematories in America.....	8vo,	2 00
Method and Devices for Bacterial Treatment of Sewage.....	8vo,	3 00
Ward and Whipple's Freshwater Biology. (In Press.)		
Whipple's Microscopy of Drinking-water.....	8vo,	3 50
* Typhoid Fever.....	Large 12mo,	3 00
Value of Pure Water.....	Large 12mo,	1 00
Winton's Microscopy of Vegetable Foods.....	8vo,	7 50

### MISCELLANEOUS.

Emmons's Geological Guide-book of the Rocky Mountain Excursion of the International Congress of Geologists.....	Large 8vo,	1 50
Ferrel's Popular Treatise on the Winds.....	8vo,	4 00
Fitzgerald's Boston Machinist.....	18mo,	1 00
Gannett's Statistical Abstract of the World.....	24mo,	75
Haines's American Railway Management.....	12mo,	2 50
* Hanusek's The Microscopy of Technical Products. (Winton).....	8vo,	5 00
Ricketts's History of Rensselaer Polytechnic Institute 1824-1894.....	Large 12mo,	3 00
Rotherham's Emphasized New Testament.....	Large 8vo,	2 00
Standage's Decoration of Wood, Glass, Metal, etc.....	12mo,	2 00
Thome's Structural and Physiological Botany. (Bennett).....	16mo,	2 25
Westermaier's Compendium of General Botany. (Schneider).....	8vo,	2 00
Winslow's Elements of Applied Microscopy.....	12mo,	1 50

### HEBREW AND CHALDEE TEXT-BOOKS.

Green's Elementary Hebrew Grammar.....	12mo,	1 25
Gesenius's Hebrew and Chaldee Lexicon to the Old Testament Scriptures. (Tregelles).....	Small 4to, half morocco,	5 00



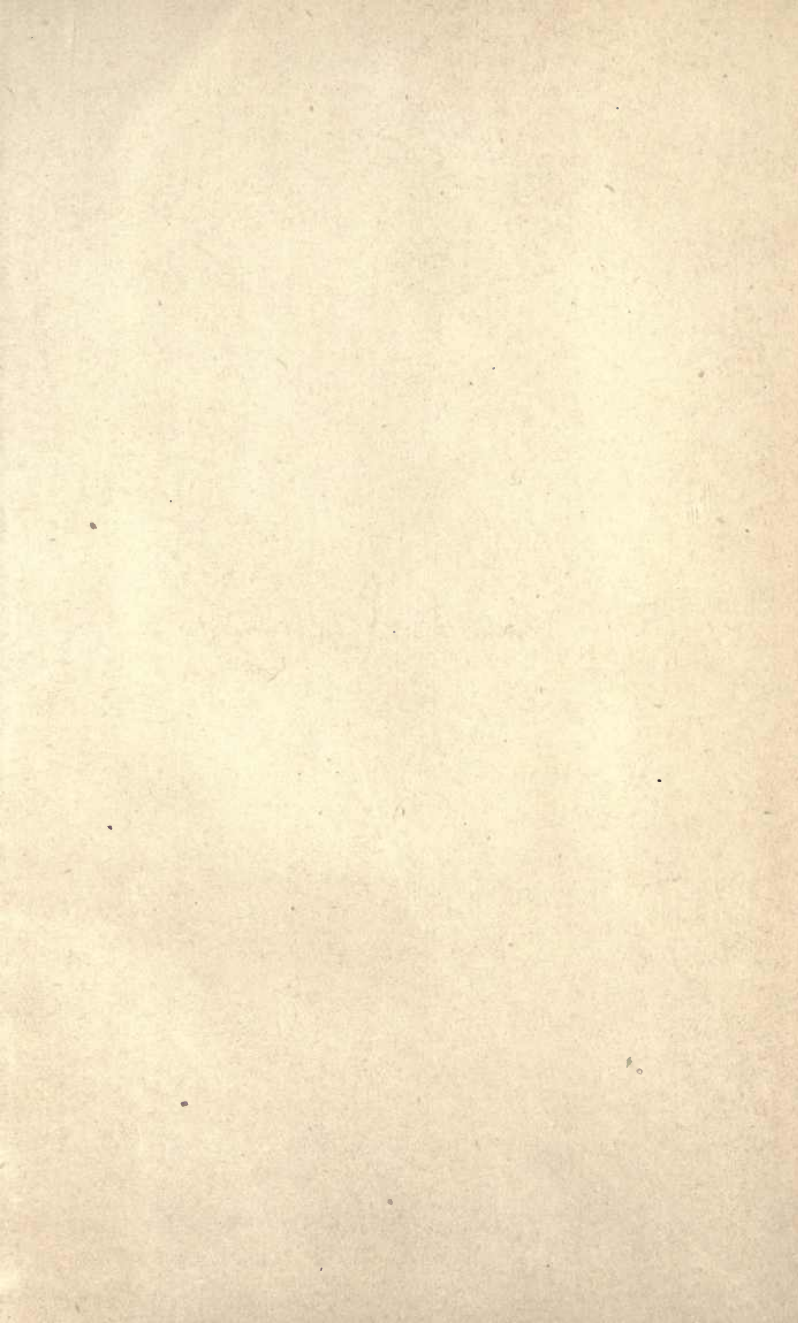







ura  
pes S

UNIVERSITY OF CALIFORNIA LIBRARY,  
BERKELEY

**THIS BOOK IS DUE ON THE LAST DATE  
STAMPED BELOW**

Books not returned on time are subject to a fine of 50c per volume after the third day overdue, increasing to \$1.00 per volume after the sixth day. Books not in demand may be renewed if application is made before expiration of loan period.

MAR 18 1921

20m-11,'20

YB 38407

TN767  
W 7  
1908  
Wilson

177754



