

UC-NRLF



B 3 057 428

★★

LIBRARY

OF THE

University of California.

No.

1169<sup>a</sup>

Division

Range

Shelf

Received January 1875



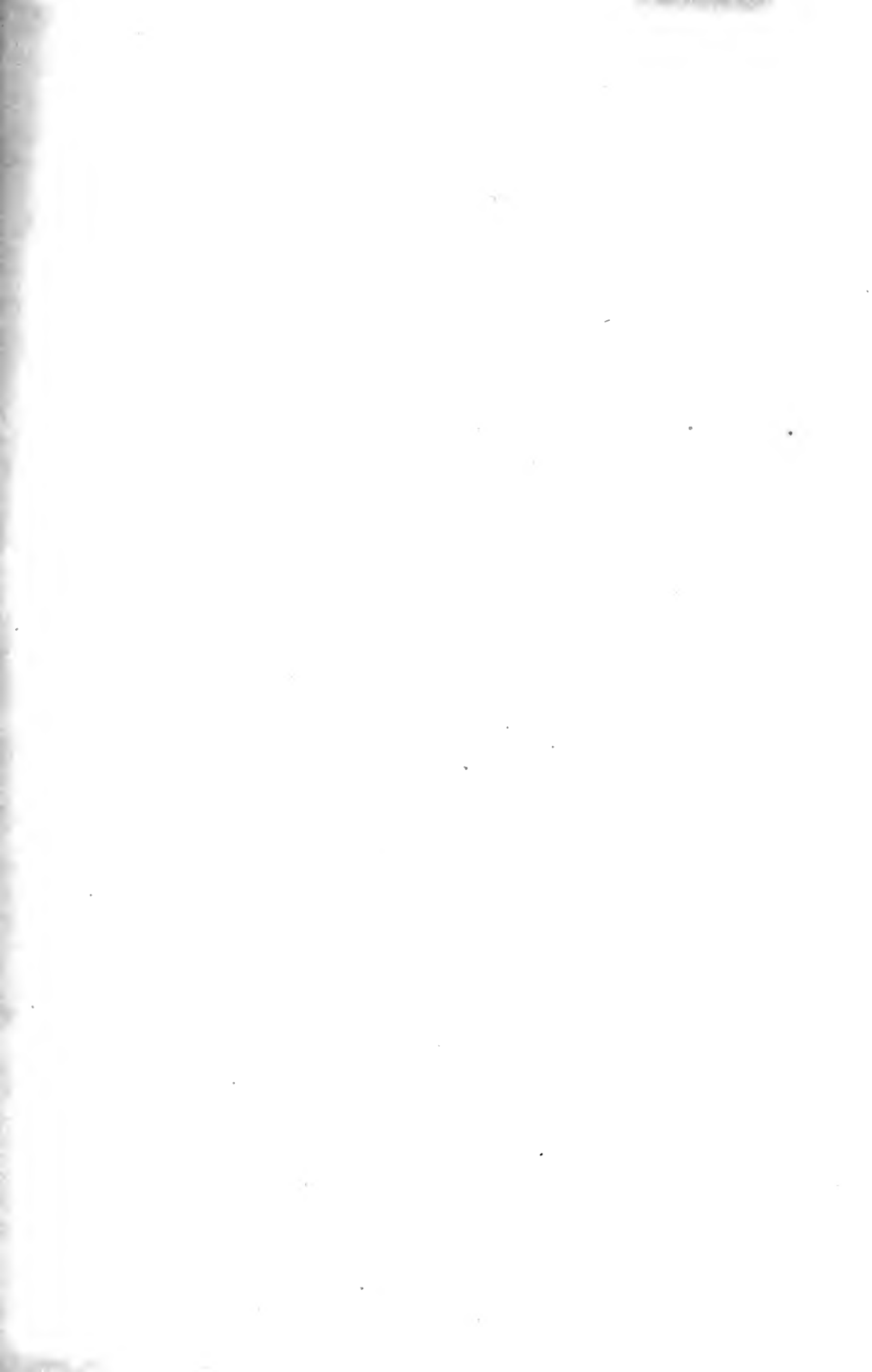

THE  
AMERICAN CYCLOPÆDIA.

---

VOL. VI.  
DEMPSTER—EVERETT.



T H E

# AMERICAN CYCLOPÆDIA:

A

*Popular Dictionary*

OF

## GENERAL KNOWLEDGE.

EDITED BY

GEORGE RIPLEY AND CHARLES A. DANA.

VOLUME VI.

DEMPSTER—EVERETT.

NEW YORK:

D. APPLETON AND COMPANY,

549 AND 551 BROADWAY.

LONDON: 16 LITTLE BRITAIN.

1874.

7 E 5  
A 5  
1873  
V. 5

ENTERED, according to Act of Congress, in the year 1859, by D. APPLETON AND COMPANY, in the Clerk's Office of the District Court of the United States for the Southern District of New York.

ENTERED, according to Act of Congress, in the year 1874, by D. APPLETON AND COMPANY, in the Office of the Librarian of Congress, at Washington.

11698



*Among the Contributors of New Articles to the Sixth Volume of the Revised Edition are the following :*

- Prof. CLEVELAND ABBÉ, Washington, D. C.  
DEV.  
EARTHQUAKE.  
ECHO.  
ELASTICITY.
- Prof. C. W. BENNETT, D. D., Syracuse University.  
DEMPSTER, JOHN.  
DICKINS, JOHN.  
DURBIN, JOHN PRICE, D. D.  
EMERY, JOHN and ROBERT.
- FRANCIS C. BOWMAN.  
DUSSEK, JOHN LOUIS,  
ERNST, HEINRICH WILHELM,  
and other musical articles.
- W. T. BRIGHAM, Esq., Boston.  
EUCALYPTUS,  
EUPHORBIA,  
and other botanical articles.
- EDWARD L. BURLINGAME, Ph. D.  
DOUGLAS, FAMILY OF,  
DRESDEN,  
EPAMINONDAS,  
and other articles in biography and geography.
- ROBERT CARTER.  
DIPPEL, JOHANN KONRAD,  
DISRAELI, BENJAMIN and ISAAC,  
DOUGLAS, STEPHEN ARNOLD,  
EASTER ISLAND,  
EGYPT,  
and other articles in biography and geography.
- JOHN D. CHAMPLIN, Jr.  
DIANA,  
DONATI,  
DREAM,  
DRUSUS,  
ENGRAVING,  
ERCKMANN-CHATRIAN,  
and articles in biography and geography.
- Prof. E. H. CLARKE, M. D., Harvard University.  
DIAPHORETICS,  
ELATERIUM,  
ETHER,  
and other articles of materia medica.
- Hon. T. M. COOLEY, LL. D., Ann Arbor, Mich.  
DIVORCE,  
DOMAIN,  
DOMICILE,  
DOWER,  
EASEMENT,  
and other legal articles.
- Prof. J. C. DALTON, M. D.  
ELLIOT, GEORGE THOMSON,  
and medical and physiological articles.
- EATON S. DRONE.  
EDUCATION,  
EMIGRATION,  
and various articles in American geography.
- Col. H. A. DU PONT, U. S. A.  
DU PONT, SAMUEL FRANCIS.  
DU PONT DE NEMOURS, PIERRE SAMUEL.
- ROBERT T. EDES, M. D., Harvard University.  
Articles in materia medica.
- W. M. FERRISS.  
ELLET, CHARLES, Jr.
- A. K. FISKE.  
DERBY, Eng.  
DERBY, EARLS OF.
- Prof. AUSTIN FLINT, M. D.  
DENGUE.  
DIPHTHERIA.  
DROPSY.
- J. W. HAWES.  
DETROIT,  
DISTRICT OF COLUMBIA,  
DULUTH,  
EVANSVILLE,  
and other articles in American geography.
- CHARLES L. HOGEBOOM, M. D.  
DEXTRINE.  
DIAL.  
DIASTASE.  
DIATHERMANCY.  
DOCK.  
ELECTRICITY.  
ETHER, COSMIC.
- Prof. T. STERRY HUNT, LL. D., Mass. Inst. of Technology, Boston.  
DILUVIUM.
- ROSSITER JOINSON.  
DE WITT, JAN.  
DICKENS, CHARLES,  
and other articles in biography.
- Prof. C. A. JOY, Ph. D., Columbia College, New York.  
DIALYSIS,  
DISSOCIATION,  
ERBBIUM,  
and other chemical articles.
- Prof. S. KNEELAND, M. D., Mass. Inst. of Technology, Boston.  
DENTALIUM,  
ECHINODERMS,  
ECHINUS,  
ELASMOSAURIANS,  
Eozoön,  
and other articles in natural history.
- Rev. FRANKLIN NOBLE.  
DISSENTERS.  
EPIHESUS.  
EVANGELICAL ALLIANCE.
- Rev. BERNARD O'REILLY, D. D.  
DIOCESE.  
DONATISTS.  
DUPANLOUP, FÉLIX ANTOINE PHILIPPE.  
EUGENIUS, popes.  
EUSEBIUS.
- Count L. F. DE POURTALÈS, U. S. Coast Survey.  
DREDGING (Deep-Sea).
- RICHARD A. PROCTOR, A. M., London.  
DOG STAR.  
EARTH.  
ECLIPSE.  
ECLIPTIC.
- Prof. A. J. SCHEM.  
EPIHESIANS, EPISTLE TO THE.
- J. G. SHEA, LL. D.  
ERIES.  
ETECHEMINS,  
and other articles on American Indians.
- Prof. J. A. SPENCER, D. D., College of the City of New York.  
DIX, MORGAN, D. D.  
DONALDSON, JOHN WILLIAM.  
DUFORT, JAMES.  
DYCE, ALEXANDER.
- EMERICH SZABAD.  
DENMARK.
- Prof. G. A. F. VAN RHYN, Ph. D.  
EDDA,  
EGYPT, LANGUAGE AND LITERATURE OF,  
ETHIOPIA,  
ETHIOPIA, LANGUAGES AND LITERATURE OF,  
ETHNOLOGY,  
ETRURIA,  
and other philological, archæological, and oriental articles.
- I. DE VEITELLE.  
DURANGO,  
ECUADOR,  
ENTRE RIOS,  
ESPIRITO SANTO,  
and other Spanish-American articles.
- Gen. JAMES GRANT WILSON.  
DRAKE, JOSEPH RODMAN.



THE  
AMERICAN CYCLOPÆDIA.

---

DEMPSTER

**D**EMPSTER, John, an American clergyman, born in Florida, Fulton co., N. Y., Jan. 2, 1794, died at Evanston, Ill., Nov. 28, 1863. His father, the Rev. James Dempster, though educated at the university of Edinburgh and bred a Presbyterian, was a colaborer with John Wesley, and was sent by him as a missionary to America, and died while his son was a child. Becoming a peddler of tinware, young Dempster manifested no marked characteristics till his conversion in his 18th year, when he set about repairing the defects of his earlier education by most persistent study. In 1816 he was admitted into the Methodist general conference, and till 1825 was stationed at various places in Canada and New York. In 1835 he was sent as missionary to Buenos Ayres. Returning in 1842, for three years he had charge of churches in New York city. Meanwhile he had decided on Newbury, Vt., as a favorable site for a theological seminary, which soon after was removed to Concord, N. H. Here in 1847 was inaugurated the Biblical institute, which now constitutes the school of theology of Boston university. After seven years' labor in this institute, Dr. Dempster departed for the west, to seek a favorable location for the second in the chain of theological seminaries that he proposed to establish between the Atlantic and Pacific coasts. A property for the adequate endowment of a Biblical institute in or near Chicago was obtained, and he was appointed senior professor in 1856. The steps he had taken for planting like institutions at Omaha, and next in California, failed, chiefly from the financial revulsion which the entire country suffered in 1857. Preparatory to a contemplated journey to the Pacific coast to further his favorite plan, he submitted to a surgical operation that proved fatal. He left very extensive manuscripts, only one volume of which has been published, "Lectures and Addresses" (Cincinnati, 1864).

**D**EMPSTER, Thomas, a Scottish professor and author, born at Muiresk, Aberdeenshire, Aug. 23, 1579, died near Bologna, Sept. 6, 1625. He was the 24th in a family of 29 children by the same mother, and at the age of three mastered the alphabet in one hour. He went in his 10th year to the university of Cambridge, and studied for some time at Pembroke hall, whence he passed over to France. For several years he wandered from one university to another, and in 1596 he received the degree of D. C. L., and was appointed regent of the college of Navarre in Paris. His violent and quarrelsome temper often involved him in serious broils with his fellow students and professors. He was subsequently engaged as professor for brief periods at Toulouse and Nîmes, and early in the 17th century went to Scotland to recover a portion of the paternal property. Returning to Paris, he was for seven years connected with various colleges of the university, and while acting as temporary principal of the collège de Beauvais he preserved the most rigid discipline in that institution. He afterward went to England, and was appointed by James I. historiographer royal. In 1615 he received from the king a handsome present in money, but his hopes of preferment being defeated by the opposition of the clergy on account of his being a Roman Catholic, he betook himself in 1616 to Pisa, where for several years he lectured on the civil law. A personal difficulty induced him to go to Bologna, where, after engaging in a number of disputes, he rose to eminence as professor of humanity; was knighted and pensioned by the pope, and loaded with distinctions. In the midst of this prosperity his wife eloped with a student, and the mental and physical suffering which he experienced in an attempt to overtake the fugitives put an end to his life. Dempster's works are exceedingly numerous, and embrace a variety of subjects. He wrote

and spoke Greek and Latin with great facility, and was thoroughly versed in philosophy, civil law, and history. His elaborate works, *Antiquitatum Romanarum Corpus Absolutissimum* and *De Etruria Regali*, evince remarkable industry and erudition. His *Historia Ecclesiastica Gentis Scotorum* is a biographical dictionary of Scottish worthies, in which fable and fact are mingled. Many names of authors who never were in Scotland are claimed as Scottish, and the history of many others who never existed is given with minute particularity. He was as remarkable for personal courage and skill in the use of weapons as for scholarship.

**DEMURRAGE** (Lat. *demoror*, to delay), in maritime law, the detention of a vessel beyond the time allowed by the charter party (or by custom if there is no special contract) for loading or unloading or sailing; also the compensation paid or damages claimed for such detention. It is usually stipulated in the contract between the owner of the ship and the freighter that the ship shall not be detained beyond a certain time for the loading or delivery of goods, or for sailing. If there is no such stipulation, the time is fixed by usage, and called lay days. The claim for demurrage is reciprocal, by the owner against the freighter, and by the freighter against the owner; the latter case being, however, only for delay in sailing. Demurrage is allowed only for voluntary detention, and not for any accidental delay; as, if a vessel is detained for a cargo over the stipulated time, and after sailing is driven back by a storm, which would have been avoided if she had started at the time appointed, no damages are allowed for the incidental delay. Yet it would perhaps be otherwise if by the detention a further delay is caused by anything which could be foreseen, as a periodical wind, or the freezing up of a harbor, or the like. In inland transportation, where the latter cause of delay most frequently occurs, as upon rivers or canals, the rule is that the carrier is not responsible for the delay when there has been no fault on his part, but is entitled to deliver the cargo after the breaking up of winter, and earn the entire freight; or if the freighter elect to take the goods at the place of detention, he must pay *pro rata itineris*. But if there has been voluntary delay by either party, in consequence of which the vessel is frozen up by the coming on of winter, he is responsible for damages; but the measure of such damages would not be according to the rule of demurrage in respect to sea vessels.

**DEMURRER**, in law, an exception by a party to a suit to the sufficiency of the pleading of the opposite party. In the common law courts a demurrer may be general or special; the former specifying no particular ground of objection, and therefore raising only the question of the sufficiency in substance of the pleading demurred to; the latter being a specification of certain objections to the form of the plead-

ing. It may be interposed by either party to the last pleading of his opponent, but on the argument the sufficiency of any prior pleading may be inquired into, and judgment will be given against the party committing the first substantial error. In equity the demurrer is only applicable to the complainant's bill. A demurrer always raises a question of law to be determined by the court; but if the pleading demurred to is held bad, liberty to amend is usually given, unless the case is such that amendment can be of no avail.

**DENAIN**, a town of France, in the department of Le Nord, on the left bank of the Scheldt, which is here navigable, and on the Northern railway, 6 m. W. S. W. of Valenciennes, and 14 m. E. S. E. of Douai. Owing to the successful working of the neighboring coal and iron mines, the population increased from 900 in 1826 to 11,022 in 1866. The town has manufactories of iron and of beet sugar. Denain was the scene of a brilliant victory achieved in 1712 by the French under Villars over an army of the allies commanded by the earl of Albemarle.

**DENARIUS**, a Roman silver coin, containing at first 10, and afterward 16 ases, first coined in 269 B. C. The average weight of a large number of denarii shows them to have con-

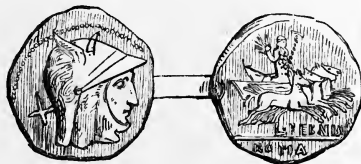

Roman Denarius (exact size).

tained about as much silver as three half dimes of our currency. The *denarius aureus* was a gold coin, the average value and weight of which it is difficult to determine. The specimens in the British museum differ much in these respects. The gold denarius does not seem to have been in common use in Rome.

**DENBIGH**, a municipal and parliamentary borough, market and county town of Denbighshire, North Wales, built on an eminence near the centre of the vale of Clwyd, 22 m. W. of Chester, and 180 m. N. W. of London; pop. of the borough in 1871, 6,322. The principal edifices are three Anglican churches, one Catholic and four dissenting chapels, a town hall, grammar-school, lunatic asylum, and a spacious market hall. The shoe and leather trade is the main support of the town, but Denbigh is best known as a pleasant spot for retirement. Denbigh castle, a magnificent edifice, parts of which are well preserved, is supposed to have been built by Henry Lacy, earl of Lincoln, who received the lordship of this place from Edward I. Edward IV. was besieged in it by the army of Henry VI., and Charles I. took refuge here after the battle of Rowton Heath in 1645. At the close of the civil war it was garrisoned by royalists, but after a siege of two months

surrendered to the parliamentarians by order of the king. A great part of its defences was blown up after the restoration.

**DENBIGHSHIRE**, a maritime county of North Wales, bounded N. by the Irish sea, and bordering on England; area, 603 sq. m.; pop. in 1871, 104,266. Its surface is much diversified; there are some level tracts in the north, but along the E. and W. borders extend mountain ridges. The principal rivers are the Conway, Dee, and Clwyd, none of which are navigable within its borders. The valleys and level tracts are remarkably fertile, producing grain, beans, and peas; the uplands yield some crops of barley, oats, and potatoes, but are mostly occupied by pastures; cattle, sheep, and goats are reared in great numbers, and excellent cheese is made. Among the minerals are coal and iron, both very valuable, lead, slate, freestone, and millstone. Immense quantities of limestone, used for fluxing ironstone, are exported into Staffordshire, and the yield of one quarry, near Llan-gollen, is said to be sometimes between 70,000 and 100,000 tons in a single year. The county has no seaport, and its chief channel of transportation is the Chester and Holyhead railway, which crosses it near the coast. The Chester and Shrewsbury railway runs S. about 14 m., just within its E. boundary. A branch of the Ellesmere canal traverses the vale of Llan-gollen. The chief towns are Denbigh, Ruthin, and Wrexham.—Before the Roman conquest

Denbighshire was the territory of the Ordovices, and it was annexed to the empire only after long struggles. It contains several interesting Roman remains. It was the scene of many fierce contests under the Saxons and the Normans, in the wars of the Roses, and in the revolution of the 17th century.

**DENDERAH** (anc. *Tentyra*), a ruined town of Upper Egypt, near the left bank of the Nile, in lat. 26° 10' N., lon. 32° 37' E., 40 m. E. S. E. of Girgeh. Its antiquities are among the most interesting and complete in Egypt. The principal building is a magnificent temple, enclosed with some other edifices, in a space 1,000 ft. square, by a wall of sun-dried brick, 15 ft. thick and 35 ft. high. It was dedicated to the goddess Athor or Aphrodite, or, as some believe, to Isis. A richly sculptured gateway faces it in the enclosing wall, on which the emperors Domitian and Trajan, whose names occur in accompanying inscriptions, are represented in the act of worship. The portico of the temple

is 135 ft. wide, and has 24 columns arranged four deep, each 32 ft. high and nearly 22 ft. in circumference. The capitals have a full face of the presiding divinity on each of their four sides; the architrave is covered like the portal with sculptures representing a religious procession, and the projecting fillet of the cornice bears an inscription in Greek setting forth that the portico was added to the temple in the reign of Tiberius Cæsar, in honor of the goddess Aphrodite. On the ceiling of the portico is the famous basso-relievo, at first supposed to represent the signs of the zodiac and to be of very remote antiquity, discovered in 1799 by the French savants under Bonaparte; and on the ceiling of one of the inner chambers was a small and somewhat similar planisphere, which was removed to Paris in 1821. But the supposed zodiac lacks the sign of Cancer, and all scholars are now agreed that it is not older



Ruins at Denderah.

than the Ptolemies, and that a zodiac was not used under the Pharaohs. In the portico or on the front of the temple may be distinguished the names of Augustus, Caligula, Claudius, Nero, Ptolemy Cæsarion, and his mother Cleopatra. The last two are also represented by rude portraits. The interior consists of three large halls, an isolated sanctuary, and several small chambers. Rows of columns stand in some of the rooms, displaying on their capitals the budding lotus, and all the apartments but two are profusely sculptured. The roof is flat and formed of oblong masses of stone. Small holes cut in the ceiling or sides admitted the light, and some of the rooms on the ground floor were lighted only by the few rays which found their way through apertures communicating with the rooms above. There are two smaller temples of Roman date near that of Athor, one dedicated to Isis.

**DENDERMONDE**, or **Termonde**, a town of Belgium, in the province of East Flanders, at the

junction of the Scheldt and Dender rivers, 16 m. N. W. of Brussels; pop. in 1867, 8,300. It contains nine places of worship, many charitable and educational institutions, an academy of design and architecture, and several fine private collections of art. In the church of Notre Dame are two pictures by Vandyke and other works of art. The surrounding country is fertile, and produces the finest flax in Flanders. An active trade is carried on in this article, in grain, linseed, hemp, and oil, and in various manufactures, the most important of which are woollen cloths, cotton yarn, and lace. The town is supposed to date from the 8th century. Many Roman antiquities have been found in the neighborhood. In 1667 it resisted a siege of Louis XIV. by opening the sluices. In 1706 it was taken by Marlborough only after a long drought, and in 1745 by the French. The present fortifications date from 1822, and the bridge over the Scheldt from 1825.

**DENDROBIUM**, a genus of epiphytes or parasitical plants, found chiefly in the damp tropical parts of Asia, and belonging to an order remarkable for the grotesqueness as well as beauty of its flowers. The species number more than 200, and vary from a very small plant to a very tall one. In some instances they affect dry and open places on the bark of trees in Australia, and even on bare rocks exposed to the sun. Dr. Royle found *D. alpestre* on the Himalaya mountains, at an elevation of 7,500 ft. The flowers of most species are of some shade of purple; some are of a rich yellow, and a few are green. They possess a high fragrance. In cultivation they thrive best when planted in pots filled with earth, but require an artificially elevated temperature to insure success.

**DENGUE**, a term of uncertain derivation, used to denote an epidemic disease popularly known in this country as the breakbone fever. It prevailed extensively in the West India islands in 1827 and 1828, and at the same time in many parts of the southern states of the Union. It was at that time described by Prof. Dickson, then a resident of Charleston, S. C., and the same author subsequently published several papers relating to it. It prevailed in Philadelphia in 1780, and was described by Dr. Rush. It is supposed to be identical with epidemics variously designated which have occurred at different periods in other parts of the world. The disease is an essential fever which has a short career, the average duration being about 36 hours. Sometimes it commences abruptly, and sometimes the development occupies several days. The usual symptoms of fever are present, namely, frequency of the pulse, increase of temperature, loss of appetite, chilly sensations, thirst, lassitude, &c. The disease, however, is characterized by excruciating pains in the head and eyes, and in the muscles of the neck, loins, and extremities; hence the name breakbone fever. An eruption frequently occurs, but its character differs in different cases.

It resembles sometimes the eruption of scarlatina; hence the name *scarlatina rheumatica* has been applied to an epidemic supposed to be identical with this by Cooke and Copland. The eruption in some cases resembles that of measles, and in other cases it is like lichen or urticaria. Vesicles like those of sudamina and varicella have been observed. Erysipelas and purpura may occur, the latter being sometimes accompanied by hæmorrhage from the nose, mouth, bowels, or uterus. Convalescence is apt to be tedious, and relapses are not uncommon. Rheumatism, abscesses, boils, and carbuncles are occasional sequels. This epidemic rarely occurs except in warm climates, and it prevails especially in cities and large towns. The number of persons affected is sometimes remarkable. Dr. Wragg computed the number of cases at one time in Charleston, S. C., at 10,000, and during the epidemic seven or eight tenths of the population were affected. It attacks persons of either sex and of all ages. The epidemics have a brief duration, rarely extending beyond six or eight weeks. The causes are unknown. Prof. Dickson regarded the disease as contagious, but this view is not generally held, and it is opposed by facts which render it untenable. Although the intensity of the fever is great, the disease is rarely if ever fatal. This is explained by its short duration, and the absence of any important complications. The treatment consists chiefly in the use of opium in some form to alleviate the pains, and in other palliative measures. The convalescence is hastened by tonic remedies, together with a restorative diet.

**DENHAM, Dixon**, an English traveller, born in London, Jan. 1, 1786, died in Free Town, Sierra Leone, June 9, 1828. He entered the British army in 1811, and served with credit through the Peninsular war and in all the subsequent campaigns against Napoleon. In 1815 he travelled through France and Italy, and on returning to England devoted himself to military studies. In 1821 he joined the government expedition to Africa, under Oudney and Clapperton, with the rank of major. Setting out from Tripoli, the expedition arrived at Moorzook, in Fezzan, April 8, 1822. Here its progress was stopped by the refusal of the sultan of Fezzan to furnish an escort across the desert. After considerable trouble Denham started for England to lay the matter before the government, but was recalled from Marseilles, where he was detained in quarantine, the expedition having received an escort and permission to proceed, mainly in consequence of his activity and firmness. They crossed the desert to Lake Tchad, which they reached in February, 1823. Leaving his companions at Kuka to recruit their health, Denham explored the region around the lake, and afterward joined an expedition of the Arab escort against the natives to the southward. In a disastrous fight Denham was wounded and separated from the company, and found his way back to Kuka through great

perils and suffering. He afterward continued his explorations of the interior, and returned to England with Clapperton in 1825. In 1826 he published in London his "Narrative of Travels and Discoveries in Northern and Central Africa, in the years 1822, 1823, and 1824." In the same year he was promoted to the rank of lieutenant colonel and appointed superintendent of the liberated African department of Sierra Leone, and in 1828 governor of the colony.

**DENHAM**, Sir John, an English poet, born in Dublin in 1615, died in London, March 19, 1668. In 1641 he published "The Sophy," a tragedy, which was praised by Waller, and had an immediate success; and in 1643 appeared his poem "Cooper's Hill," on which his fame rests. The following two famous lines occur in the apostrophe to the Thames in that poem:

Though deep, yet clear; though gentle, yet not dull;  
Strong without rage, without o'erflowing full.

During the imprisonment of Charles I. Denham performed many secret services for him, and being detected fled to France. On the restoration he was appointed surveyor general of the royal buildings.

**DENINA**, Giacomo Maria Carlo, an Italian historian, born at Revello, Piedmont, Feb. 28, 1731, died in Paris, Dec. 5, 1813. He took holy orders, acted as professor at Pinerolo and Turin, and was subjected to persecutions on the part of the Jesuits. About 1782 he went to Berlin, in compliance with an invitation of Frederick the Great, and wrote there his *Rivoluzioni della Germania* (8 vols., Florence, 1804), several works on North German literature (in French), and an effusion in praise of Peter the Great (*La Russiade*, Berlin, 1790). While at Mentz in 1804 he was introduced to Napoleon, to whom he dedicated his *Clef des langues* (Berlin, 1804), and who shortly afterward appointed him imperial librarian at Paris. Denina wrote many other literary, critical, and historical works; but his literary fame rests chiefly upon his *Istoria delle rivoluzioni d'Italia* (3 vols., Turin, 1769-'70; best edition, Milan, 1820; translated into several European languages), which contains a general history of that country from the time of the Etruscans. He left in manuscript three volumes of a history of Piedmont, which have not been published in Italian, but have appeared in German.

**DEMIS**, or **Denys** (Lat. DIONYSIUS), Saint, apostle and first bishop of Paris in the 3d century. He was one of a company of missionaries who were sent from Rome, about 250, to revive the drooping church in Gaul; and after preaching in various parts of that country and suffering much at the hands of the pagans, he arrived at Lutetia (Paris), where he made many converts. He built a church there, and made it the seat of his bishopric. During the persecution under Aurelian he was condemned to death by the Roman governor Pescennius, and with a priest named Rusticus, and a deacon Eleutherus, was beheaded in 272. The bodies

were thrown into the Seine, but were recovered by a Christian woman, Catulla, who caused them to be interred near the scene of the execution. A chapel was built over the spot, and after it had fallen to ruin was replaced by St. Genevieve with a church in 469, which was afterward united to the famous abbey of St. Denis, founded by Dagobert about 636. St. Denis became the patron of the kingdom, and his name served as a war cry to the French, who used to rally in battle at the words *Montjoye Saint Denis*. His festival is kept Oct. 9. The popular belief that after his decapitation he walked about with his head in his hands may have originated in the ancient paintings, which represented him so engaged, as an emblem of the manner of his death.

**DENIZEN**, in English law, an alien born who has received by letters patent from the king certain privileges belonging to natural born subjects. Thus he may take lands by purchase or devise, but not by descent. In American law there is no middle class of this kind between aliens and citizens, unless we may designate as such those who have declared an intention to become citizens, but have not become fully naturalized. In some of the states, by statute, such persons are allowed to take and convey real estate, the difference between them and aliens being that, although the latter can take real estate and hold it until some proceeding is taken by public authority to divest the title, commonly called office-found (*i. e.*, an inquest by official action), yet upon such proceeding being had, the land would escheat to the state although the alien should have conveyed to another. Another signification is sometimes attached to the term, in a more popular sense, though it is also to be found in some law writers, viz., a resident. This meaning is not wholly inconsistent with the other, as it may at an early period, when the doctrine of citizenship was not well settled, have been understood of the children of aliens born in England. By the present law of that country such children are recognized as subjects, except in certain cases, as the children of persons representing or in the service of foreign governments who are temporarily in England. The same rule is recognized in the United States, and as a consequence it was thought necessary to provide by law that the children of Americans born abroad should be held to be American citizens.

**DENIZLI**, a town of Asia Minor, on the main road between Smyrna and Isbarta, 110 m. S. E. of the former and 70 m. W. of the latter place; lat. 37° 50' N., lon. 29° 15' E.; pop. about 7,000. The town, which is situated not far from the base of the Baba Dagh (the ancient Mount Cadmus, on the confines of Caria and Phrygia), in a well wooded country, has been called the Damascus of Anatolia on account of the beauty of its surroundings. There are many villas in its environs, and the hills are covered with vineyards. Within the town

are two khans, a bazaar, and numerous tanneries. The chief manufactures are red and yellow leather and morocco, made from sheep and goat skins, raisins, and a kind of grape sirup which is used instead of sugar. Denizli is the capital of a sanjak in the vilayet of Aidin. In 1715 it was destroyed by an earthquake, in which 12,000 people perished. About 5 m. N. is the town of Eski Hisar, with the ruins of ancient Laodicea.

**DENMAN, Thomas**, lord chief justice of England, born in London, Feb. 23, 1779, died at Stoke Albany, Northamptonshire, Sept. 22, 1854. The only son of Thomas Denman, M. D., author of a well known work on midwifery, he graduated in 1800 at St. John's college, Cambridge, was called to the bar in 1806, returned to parliament for Wareham at the general election of 1818, and in 1820 for Nottingham, representing that town from this time till 1826, and again in 1830-'31. In 1820 he took a distinguished part as solicitor in the trial of Queen Caroline. In 1822 he was appointed common serjeant of the city of London; from 1830 to 1832 he was attorney general; and from 1832 till 1850, he was chief justice of the king's bench. He was raised to the peerage in 1834. His "Life," by Sir Joseph Arnould, was published in 1873.

**DENMARK** (Dan. *Danmark*, Ger. *Dänemark*, Fr. *Danemark*, "the land or mark of the Dane;" called also the *Danske Stat*, "state of Denmark"), a kingdom in the north of Europe, situated between lat. 54° 30' and 57° 45' N., and lon. 8° 5' and 12° 45' E.; the small island of Bornholm, in the Baltic, lies in lon. 15° E. It is bounded N. E. by the Skager Rack, N. E. and E. by the Cattegat, the Sound, and the Baltic, S. by Femern strait, the Little Belt, and Schleswig, and W. by the North sea. It consists of the peninsula of Jutland and the islands of Seeland, Fünen, Laaland, Falster, Langeland, Møen, Samsø, Läsö, Arrö, Bornholm, and many smaller ones; besides which it possesses the Faroe islands, Iceland, and Greenland, and the islands of Santa Cruz, St. Thomas, and St. John, in the West Indies. The following table shows the area and population of Denmark and its colonies in 1870:

MAIN DIVISIONS.	Area in sq. m.	Population.
Seeland, Møen, and Samsø.....	2,884	637,711
Bornholm.....	225	31,894
Fünen, Langeland, and Arrö.....	1,815	236,311
Laaland, Falster, &c.....	640	90,706
Jutland.....	9,738	788,119
	14,752	1,784,741
COLONIES.		
Faroe islands.....	510	9,992
Iceland.....	39,758	69,763
Greenland (region free from ice).....	46,774	9,825
West India Islands.....	119	37,821
Total.....	87,161	127,401

The Danish colonies in the East Indies and Africa were acquired by Great Britain in 1846.

The duchies of Schleswig, Holstein, and Lauenburg, which formed more than one third of the kingdom, were lost by the Danish crown in 1864.—The seacoast of Denmark, along the North sea, the Skager Rack, the Cattegat, the Sound, the Baltic, and the Little Belt, is more than 900 m. long, and generally low, flat, and sandy. Next to Copenhagen the principal seaports are Elsinore, Odense, Aarhus, Aalborg, and Frederikshavn. The fiords or arms of the sea which indent the coasts are among the most remarkable natural features of the kingdom. The Liim or Lym fiord entirely insulates the N. part of Jutland; it was formerly separated from the North sea by a narrow strip of land, through which in 1825 the sea broke in two places. The Ringkiöbing fiord in W. Jutland and the Ise fiords in Seeland are also notable for their size. The lakes are numerous, but small, and some contain excellent fish. Since the loss of the duchies, the only rivers deserving mention are the Varde, flowing into the North sea, and the Guden, 80 m. long, flowing into the Cattegat. The broad passage called the Great Belt lies between the islands of Seeland and Fünen, and the Little Belt separates Fünen from Jutland and Schleswig. The surface of the kingdom is an almost unbroken plain, in most places but a few feet above the ocean, and in others below the level of the sea. The N. W. part of the peninsula is a desolate region, over which tempests and drifting sands sweep with destructive fury. To consolidate the soil and break the force of the winds, various kinds of trees and shrubs, of which the improvidence of former generations had nearly stripped the country, are now planted here, and their destruction is forbidden under severe penalties. From the promontory of Skagen, at the extreme north, a low barren ridge runs through Jutland, attaining an elevation of upward of 500 ft. The island of Fünen contains a range culminating at the height of 400 ft., called the Fünen Alps, and Seeland has eminences of about the same height. All the rocks belong to the tertiary and upper secondary formations, and, with hardly an exception, are disposed in regular strata. Several species of chalk are found, above which is an extensive boulder formation traversed by seams of lignite, and above this again beds of clay and marl are spread over a large part of the country. The soil is almost wholly alluvial, and in the E. part of Jutland is covered with rich vegetable mould. The N. and W. parts of Jutland, however, are sandy wastes, and for 200 m. along the coast there is an almost continuous line of sterile flats called *Klitter*. The larger islands are fertile and characterized by a rich marshy loam, interspersed with occasional tracts of moor. The climate, owing to the low and almost entirely insulated position of the country, is temperate and humid, the cold being greatest in Jutland. The winters are seldom severe for that high latitude, and rather milder than



in the northern parts of Germany, though in January and February the thermometer sometimes falls to 22° below zero. The extreme heat is about 85°. The shortest day is 6½ hours, and the longest 17½. The weather is very variable, but thunder storms seldom occur. Violent winds, rains, and fogs frequently occur, and drought is rare. The mineral products are of little value, and are confined principally to fullers' earth, potters' and porcelain clays, freestone, and salt. Coal mines were formerly worked in the island of Bornholm, but are now abandoned; peat is abundant, and amber is collected on the shore of the North sea. The fine forests which once adorned Denmark have decayed or been cut down, and of the scant woods which remain, chiefly on the coast of Jutland and in the island of Fünen, one fourth is the property of the crown. Pine, beech, oak, and birch are the principal varieties of timber. The crops are wheat, rye, oats, barley, buckwheat, peas and beans, potatoes, other common vegetables, and fruits. A great portion of the land is devoted to pasturage, and the rearing of horses and cattle forms a considerable source of national wealth. Cattle are valued chiefly in connection with the dairy, from which is drawn the principal revenue of the farm. The breeds of horses are excellent for cavalry or for draught; sheep are kept more for their milk (of which butter is made) and their flesh than for their wool; there are three species of swine, and poultry of all kinds abounds. In 1866 there were 352,603 horses, 1,193,861 horned cattle, 1,875,052 sheep, and 381,512 swine. The rivers and fiords furnish valuable fish, among which are the herring, cod, mackerel, and salmon.—More than half the population are engaged in agriculture, which is conducted with great industry; but from the subdivision of land into small farms it is seldom carried on with appliances requiring much outlay. The art of husbandry, however, is steadily progressing. Manufactures are also making progress. They comprise silk, linen, woollen, and cotton goods, leather, lace, gloves, straw hats, sail cloth, thread, paper, soap, glass, earthenware, plated ware, iron ware, saltpetre, gunpowder, arms, refined sugar, tobacco, soda, potash, brandy, and malt liquors. The peasantry make most of their wearing apparel and domestic utensils with their own hands.—Lying between two seas, in easy communication with all the maritime nations of Europe, commanding the entrance to the Baltic, abounding in good harbors, and possessing a large body of hardy and excellent seamen, Denmark enjoys unrivalled facilities for commerce, and besides its own import and export traffic conducts a large carrying trade for other countries. The principal articles of export are grain, butter, cheese, brandy, smoked and salted meats, horned cattle, horses, skins, hides, whale and train oils, fish, eider down, woollens, tallow, and bristles. Among the imports are wines, salt, drugs, silk, wool, cotton, cotton fabrics, timber, coal, iron,

colonial produce, spirits, glass, flax, hemp, coffee, rice, tobacco, and whalebone. During the five years 1868–72 the average annual imports from Germany and England were respectively £2,000,000 and £1,500,000, and the exports to those countries £3,500,000 and £2,300,000. The trade with Sweden and Russia is also extensive. In 1871 the entrances were 41,411 vessels of all descriptions, of 1,064,582 tons, and the clearances 41,705 vessels, of 644,052 tons; for the foreign trade alone, entered 18,457 vessels, of 745,264 tons; cleared 18,298 vessels, of 347,478 tons. The merchant marine consisted of 2,727 sailing vessels over 4 tons each, of 176,093 tons, 88 steamships of 12,007 tons, 11 tugs of 642 tons, and 10,610 boats under 4 tons. Until about the close of the 18th century the commerce of Denmark was oppressed by legislative enactments which tended more to the immediate emolument of the crown than to the general prosperity and wealth of the kingdom. Imported manufactures had to be sold at auction by the revenue officers, and the importer received the proceeds after the duties had been deducted. These duties were excessively high; monopolies were often granted to rich companies for trading even with the colonies; and heavy taxes were also laid on the domestic traffic between different provinces. But at the close of the 18th century a more liberal policy began to prevail; the customs regulations assumed the form of a more permanent tariff; many of the most burdensome restrictions were taken off, and commercial treaties have since been made on a basis of reciprocity with the United States and other nations. Connected with the commercial regulations was the question of the Sound dues, which a few years ago acquired considerable prominence. The Sound is a strait leading from the Cattegat into the Baltic, between Seeland and Sweden, its width at the narrowest part being about 3 m. Both coasts were once owned by Denmark, which has consequently from a forgotten period claimed the right of imposing tolls on all vessels navigating this passage. This exaction was from time to time resisted by various nations, and several obtained exemption either by payment of an annual commutation or by treaty. In 1848 the United States government declared its purpose not to submit any longer to the old usage. The Danish government offered to renounce its claim for a sum the interest of which would equal the annual revenue derived from the tolls; and the result of this offer was the assembling of a conference of the European powers at Copenhagen in the first months of 1856, at which Denmark agreed to accept as compensation for the removal of the tolls the sum of 35,000,000 rix dollars (\$19,145,000), payment of which was to be apportioned among the various states interested in the trade of the Baltic. The proposal was accepted by the United States as well as other powers, and a convention between the former and Denmark was signed in Washington, April 11,

1857. Great Britain paid 28·90 per cent. of the indemnity, Russia 27·80 per cent., Prussia 12·60 per cent., and the United States 2·03 per cent. or \$393,011.—The domestic shipping trade of Denmark is very large, and as no inland point is much more than 40 m. from the sea, most of the internal communication is carried on by water. The Daneskiold canal is in the island of Seeland, and that of Odense connects the capital of Fünen with the sea. The principal railroad line runs from Copenhagen via Røskilde to Korsør on the Great Belt; another line goes through the island of Fünen, and there are several lines in Jutland running from Aalborg to the frontier of Schleswig with branches. The total length of railroads at the beginning of 1872 was 530 m. In 1870 there were 1,225 m. of telegraph, with 3,160 m. of wire and 150 stations. The high roads, which are wide, macadamized, and well kept, are under the care of a corps of royal engineers.—The inhabitants of Denmark are almost entirely Scandinavians. The business language is everywhere Danish, even in the West India islands. In Iceland, and less purely in the Faroe islands, the old Norwegian or Icelandic is spoken. The Danes are an industrious, patient, and contented people, and make good soldiers and seamen. They have regular features, blue eyes, and light hair. The religion of Denmark is Lutheran, but all creeds are tolerated. The national church is governed by seven bishops nominated by the crown. It embraces almost the whole population, and has at Copenhagen a missionary college founded in 1777, and a seminary for approved candidates in divinity. According to the census of 1870, the Lutherans numbered 1,769,583; Jews, 4,290; Baptists, 3,223; Mormons, 2,128; Roman Catholics, 1,857; Reformed, 1,433; free congregations, 1,211; other sects, 811; and 205 were without any creed. The Baptists have about doubled their number during the last ten years. Some progress was also made by the Catholics, who are under the administration of a vicar apostolic. In 1873 this office was filled by the Prussian bishop of Osnabrück. Great attention is paid by government to education, and there is in the ministry a department of public worship and instruction, under which are superintendents for the several divisions of the kingdom. The ministers appoint teachers and regulate the course of studies in the public schools, of which some are free. Every village has at least one school, and there are more-over 22 gymnasia and 7 normal seminaries. There are asylums for the deaf and dumb, and literary and scientific institutions of various kinds are established throughout the country. Every child between the ages of 7 and 14 is obliged by law to attend some school, and it is rare to meet a Danish peasant, however poor, who cannot read and write. The university of Copenhagen, which dates from 1478, has 40 professors and upward of 1,100 students, and

there are colleges in all the large towns, besides 2,940 public schools. The number of periodicals is large in proportion to the population.—The government of Denmark is a hereditary constitutional monarchy. By the constitution of June 5, 1849 (which was modified in some important respects in 1855 and 1863, but was restored, with various alterations, by a statute which received the royal sanction July 28, 1866), the king must confess the Evangelical Lutheran religion, and give his oath to the privy council of state that he will maintain the fundamental laws. He attains his majority at the age of 18. All his ordinances must be countersigned by the minister of state, who is appointed by him, and is responsible to the king or diet before the supreme court of the state. The king appoints officers, declares war, and concludes treaties of peace, alliance, and trade; but he cannot alienate the territory or essentially modify the political relations of the state without the consent of the diet. By the organic law of 1866 the Danish diet or *Rigsdag* consists of two chambers, the *Folkething* or lower house, and the *Lands-thing* or upper house, which assemble every year on the first Monday in October. The proportion of representation in the lower house is one deputy for 16,000 inhabitants, the deputies being elected for three years. The upper house numbers 66 members, of whom 12 are nominated for life by the king, the rest holding their office only for eight years. The diet proposes laws, which are not valid till sanctioned by the king; and taxes cannot be imposed without its consent. The supreme court of the kingdom consists of 15 members, 5 of whom are chosen from the diet, and 10 from the high courts of the country. Personal freedom, freedom of the press, religious freedom, the inviolability of private residences, and the right of public assembly are secured. The highest court of the kingdom is the privy council of state, presided over by the king. The administration of the government is carried on by eight responsible ministries: of foreign affairs, of interior affairs, of justice, of public worship and instruction, of war, of naval affairs, of public works, and of the finances. The budget of 1873-'4 estimates the net receipts at 23,736,161 rix dollars, and the expenditures at 22,989,633. (The rix dollar is about 60 cents.) The chief source of revenue is from indirect taxes, which bring nearly 10,000,000, while the greatest expenditure is for the payment of the interest on the debt, which with the sinking fund demands upward of 7,000,000. The national debt, March 31, 1872, was 114,660,781 rix dollars.—Every able-bodied male inhabitant of the age of 22 is bound to enter the army, the term of service being four years in the line and four years in the reserve; and every person who has served his time is also liable to be enrolled under the second call. The infantry numbers 20 battalions of the line and 10 of the reserve, besides a battalion of royal guards; the cavalry consists of 5 regi-

ments; the artillery of 2, forming 12 batteries, and 2 battalions of sappers and engineers. The numerical strength of the army on a peace footing is 36,782 rank and file, with 1,058 officers; on a war footing, 47,925 rank and file. The navy in September, 1872, comprised 25 screw steamers (6 ironclads, 12 unarmored vessels, and 7 gunboats) and 6 paddle steamers. The commercial navy in 1871 numbered 2,735 vessels (exclusive of those of less than 4 tons) with an aggregate tonnage of 181,494. The principal arsenal for both army and navy is at Copenhagen, the capital and principal town.—There is no authentic account of the early settlement of Denmark, but the Cimbric seem to have occupied the continental part of it toward the end of the 2d century B. C. Some three centuries later the country was occupied by the Goths, whose chief Skiold, according to the legends the son of Odin, is mentioned as the first monarch of Denmark. During the 8th and 9th centuries the Danes, then the foremost among the Northmen (see NORTHMEN), began to acquire renown by their maritime expeditions, in which they invaded England and Scotland and conquered Normandy. In the 9th century the different states of Denmark became united under one monarch, and in 1000 and 1014 Norway and the greater part of England were added to the kingdom. In 1017 Canute, under whom Denmark became Christian, completed the conquest of England, where his race continued to rule till 1042. The feudal system was introduced into Denmark in the 12th century, and contests took place here between the sovereign and the barons similar to those which convulsed England during the same period. In 1387 Margaret, styled the northern Semiramis, widow and successor of Haco, king of Norway, and daughter of Waldemar III., a descendant of Canute, mounted the thrones of Denmark and Norway, and, claiming the Swedish crown also in right of her husband, vanquished a competitor in that country, and united the three powers by the compact of Calmar in 1397. But the Swedes always resisted this union, and after a series of contests, in which they were finally led by Gustavus Vasa, seceded from it in 1523. During this period the population dwindled, the seas swarmed with pirates, commerce fell away, and incessant quarrels between the king and his nobles or the latter and the clergy added to the disasters of the kingdom. On the deposition of Eric, Margaret's successor, in 1439, the states elected Christopher of Bavaria, and in 1448 Christian, count of Oldenburg, king, from whose grandson, Christian II. (since whose time all the kings have been alternately named Frederick and Christian), the crown passed in 1523 to Frederick I., duke of Schleswig and Holstein. Frederick's son, Christian III., united these two duchies to the crown 11 years later, and divided the greater part of them between his brothers, a measure which caused a long series of disturbances. In his reign a code of laws

called the "Recess of Kolding" was promulgated. In the 17th century Christian IV. sided with the Protestants in the great religious war, but was worsted by Wallenstein in 1626-'7, and compelled to sue for peace. Toward the end of his reign he waged several wars with Sweden, which lasted till 1645, and cost Denmark some of its provinces. A few years later the Swedes under Charles Gustavus overran Holstein, crossed the frozen Belt into Fünen, took Odense, and invested Copenhagen, but were successfully opposed by Frederick III. In 1658 they again besieged Copenhagen, and continued their operations until the death of Charles Gustavus in 1660, when Denmark secured a peace by the sacrifice of territory. The same year was marked by the restriction of the power of the nobility and the extension of the royal prerogative. The succession, too, which had formerly been to some extent elective, was by the commons, who sided with the king in his struggle with the nobles, acknowledged hereditary in the family of Frederick. A new war with Sweden terminated in 1679, and another was occasioned in 1699 by an attempt of Frederick IV. to invade the dominions of the duke of Holstein, an ally of Sweden. Copenhagen again became the seat of war, when the Danes, terrified by the energy of the young Charles XII. of Sweden, bought peace by the payment of a sum of money, and remained neutral until the disasters of the Swedes in the Ukraine tempted them to renew hostilities. The war lasted until the death of Charles XII. in 1718, after which Sweden began to decline and Denmark to pursue the wise policy of peace. The latter half of the 18th century, embracing most of the reigns of Frederick V. and Christian VII., was the period of great reforms, under the lead of the two Bernstorffs and the unfortunate Struensee. But by a defensive alliance with Russia, Prussia, and Sweden in 1801, Denmark involved herself in a quarrel with England, suffered severely in the naval battle off Copenhagen, and lost her colonies in the East and West Indies, which were restored to her, however, by the treaty of peace which followed. In 1807, when England suspected Denmark of entering into an alliance with Napoleon, an English fleet was sent to the Baltic to compel the surrender of the entire Danish navy. The British landed near the capital, and soon forced the government to give up its fleet. A war of exasperation naturally followed. Hostilities were carried on by sea, partly at the entrance to the Baltic, partly off the Norwegian coast, the Danes fighting with spirit, and sometimes with success, and both parties suffering severely in their commerce. After the reorganization of Europe by the treaties of 1814 and 1815, Denmark was obliged to cede Norway to Sweden, as an equivalent for Pomerania, which province Denmark had received from Sweden, and which in 1815 she made over to Prussia, in exchange for the duchy of

Lauenburg and a large sum of money. Serious complications, caused in part by the fact that Denmark by the possession of Holstein and Lauenburg became a member of the German confederation, now arose between the crown and the duchies. The population of Holstein especially sympathized more with Germany than with Denmark, and an antipathy of races sprung up, which various political measures deepened into an alarming disaffection. A prominent subject of complaint was the royal succession. The expected extinction of the male line in the reigning family afforded a prospect of rendering the duchies, in which the Salic law of succession prevailed, independent of the Danish crown, and the project of annexing Schleswig to the German confederation was openly advocated in the provincial assembly. In this state of affairs Christian VIII. in 1846 issued letters patent, proclaiming that with the exception of certain parts of Holstein the laws of succession should be uniform in all parts of his dominions, the effect of which was to add greatly to the popular discontent; and when Frederick VII. mounted the throne in 1848, the duchies, emboldened by the revolutionary outbreaks of the time, resorted to arms, and appealed to their German brethren for assistance. Frederick William IV. of Prussia, then forced to yield to the current of revolution, sent a large force into Schleswig under Gen. Wrangel, which drove out the Danes, who had found little difficulty in putting down the insurgents there, and followed up its success by an invasion of Jutland. Meanwhile England and Russia interfered; an armistice was signed at Malmö, Aug. 26, on terms highly displeasing to the duchies; and although Prussia undertook a second campaign in the spring and summer of 1849, Schleswig and Holstein thenceforth relied mainly on their own resources. They placed their army under Gen. Willisen, and maintained a spirited resistance, until signally defeated at Idstedt, July 25, 1850. Prussia had now definitely withdrawn from the contest, and with Austria gave her influence on the side of Denmark. The Holstein army was disbanded, the duchies were forced to submit, and the question of succession was referred to a convention of the plenipotentiaries of the principal powers of N. and W. Europe. By a treaty signed by these representatives at London, May 8, 1852, the succession was settled upon Prince Christian of the Sonderburg-Glücksburg line and his male heirs; an arrangement which gave great dissatisfaction both to Denmark and to Schleswig and Holstein, as in the event of the extinction of this family Russia reserved the ancient right of succeeding to a portion of the duchies. The new order was announced to the diet in October, 1852, and was at once rejected. It met the same fate before a new assembly in February, 1853; but the king, guided by his new prime minister Oersted, feeling himself pledged to the foreign powers, resolved upon a second

dissolution, and the measure was finally adopted by a third parliament, June 24. The settlement of the succession, however, failed to produce a real state of peace. Holstein continued to protest against the acts of the Danish government, and the agitation was communicated to Schleswig, where the German population were a small minority, and which never formed part of the German empire. Holstein carried its complaints before the German diet, which willingly exercised its right of interference and decreed a "procedure of execution," that is, compelled the Danish government to make concessions. In the midst of these troubles King Frederick VII. died (Nov. 15, 1863), and was succeeded, according to the treaty of 1852, by Prince Christian of Glücksburg, who was crowned as Christian IX.; but Holstein refused to acknowledge the new sovereign, one party supporting the pretensions of the Augustenburg family, another asking the independent union of Holstein and Schleswig, and a third desiring a union with Prussia. An Austro-Prussian army, under the command of the Prussian general Wrangel, entered Holstein early in 1864, crossed the Eider, took Eckernförde, compelled the evacuation of the Dannevirke (Feb. 5), marched through Schleswig and Jutland as far as the Lym fiord, and captured Düppel, a strong position opposite the island of Alsens, fortified with four different lines of trenches, after a two months' siege (April 18). Soon afterward the fortress of Fridericia surrendered to the Austrians. After protracted negotiations, peace was concluded at Vienna, Oct. 30, 1864, by the terms of which Denmark ceded her rights over Schleswig, Holstein, and Lauenburg to Austria and Prussia. By the convention of Gastein (August, 1865), between Austria and Prussia, the temporary management of affairs in Holstein was assumed by Austria and in Schleswig by Prussia, while Lauenburg was sold by Austria to Prussia for 2,500,000 rix dollars; Prussia besides receiving the right to occupy the port of Kiel and Rendsburg, the use of two roads through Holstein, and the right to make a canal through that country. In the treaty of Prague between Austria and Prussia, in 1866, was inserted an article providing for the retrocession of northern Schleswig, if the people by a vote should declare their wish to return to Denmark; but no vote has yet been taken. Denmark was dreadfully exhausted by the war, but has since been gradually recovering from its prostrate condition. The marriage of the Danish crown prince to the only daughter and heir of the king of Sweden in 1869 revived the idea, long cherished by many on both sides of the Sound, of a reunion of the three Scandinavian kingdoms.

**DENMARK, Language and Literature of.** The Danish language (*danske Sprog*) belongs to the Gothic family of languages, which early separated into two branches: the Norsk, or Scandinavian, and the Germanic. The former, which was called by the ancient Danes the

*norræna mal*, northern tongue, or *dönsk tunga*, Danish tongue, was spoken with little dialectic variation over the whole of Scandinavia, and was carried to Iceland by Norwegians in the latter part of the 9th century. The *norræna mal* developed into three distinct languages, Icelandic, Swedish, and Danish. While Icelandic retains the mother tongue almost unaltered, Danish has lost nearly all its distinctive features. Foreign elements were introduced into it principally in two ways: Anglo-Saxon, by the Danish invasions of England in the 11th century; German, in consequence of the warlike expeditions of the Waldemars (first, 1157-'82; second, 1202-'41; third, 1340-'75, &c.) and other Danish kings, of the wars and commerce with the Hansa, and in consequence of the rule of German dynasties (Eric VII. of Pomerania, Christopher of Bavaria, Christian I. of Oldenburg, 1448, and his successors). Its development was retarded by the use of German as the court language and of Latin as the language of literature, and in the 17th century by the inroads of French taste and phrases. In the 18th century it was again affected by the predominance of German culture, but the subsequent revival of ancient Norse studies and of a national literature developed the Danish into one of the richest and most refined European tongues. It is now not only the language of Denmark proper, but also of Norway, and of the northern part of Schleswig. It is also used in the churches among the Esquimaux in Greenland, and as a business language in the islands of Santa Cruz, St. Thomas, and St. John, in the former Danish factories in Guinea, and by well educated Icelanders. The Norwegians pronounce it a little harder than the Danes, dropping principally the soft *d*, but their literary language is entirely the same. The main difference between Danish and Swedish is that the latter has retained more of the ancient Scandinavian elements and embodied more French. Danish is also related to English and Dutch. Considering the smallness of the land in which it is spoken, it has given birth to a large number of dialects. The principal ones are: 1, the dialect of Seeland (*sjællandske*), which comprises the dialects of North Seeland (*nordsjællandske*), Copenhagen (*kjøbenhavnske*), which is the normal dialect and basis of the literary language, and the dialect of South Seeland, which includes again those of Laaland and Falster; 2, that of Fünen (*fyenske*), which is spoken in Fünen, Langeland, and several small islands; 3, that of Jutland (*jydske*), which is verbally and grammatically the most peculiar of all, and comprises the dialects of West Jutland (*vesterjydske*) and of East Jutland (*østerjydske*); 4, that of South Jutland (*sonderjydske*), also called the dialect of Schleswig (*slesvigske*), which makes use of many Anglo-Saxon and Low German words; 5, that of Bornholm (*bornholmske*), which has many affinities with Swedish; and 6, that of Schonen (*skaanske*), which is a mixture of

Swedish and the dialect of Seeland.—The alphabet numbers 28 letters, which are represented either in German or Latin characters. There are 9 vowels: *a, aa, e, i, o, u, y, æ, and ø*. *A, e, i, o, u* are pronounced as in German and Italian; *y* is sounded like the French *u*, and *ø* like the French *eu* in *peu*; *aa*, which is also a simple vowel, though written with two letters, has the sound of *ou* in brought; and *æ* corresponds to the German *ä*. They are generally long at the end of syllables and before liquids and labials, and otherwise short; *e* is, however, nearly always short at the end of a word, and becomes mute at the end of a syllable when preceded by a vowel; *ee* has the sound of *a* in late. *De*, the pronoun used in addressing a person, and corresponding to our *you*, is pronounced as if it were written *di*, in order to distinguish it from *de*, they. The consonants are the same as in English, with the exception of *w*, and are as a rule pronounced with a peculiar softness which a foreigner finds it difficult to imitate. When *d* is preceded by a vowel and stands in the middle of a word, it receives a pronunciation somewhat similar to *th* in *bathe*; it becomes mute when preceded in the same syllable by *l* or *n*, or by *r* after a long vowel, or when followed by *sk, st, t, or s* (if it is not the sign of the genitive); and it assimilates with the consonant that precedes it when it is placed between *l* and *e* or *n* and *e*, and frequently also when preceded by *ds*. When *g* stands between two vowels it is generally almost mute, and at the end of words it is sometimes as soft as an aspirate, and sometimes as hard as a *k*; *eg* is sometimes pronounced like the English *i* in *lie*, and *og* like *oy* in *toy*. In the middle of a word, before *j* and *v*, and after *t*, the letter *h* is not sounded; it serves to lengthen the vowel that precedes. In the combinations *gj, kj, and skj*, when followed by *e, æ, or ø*, the *j* is frequently silent. *N* is nasal before *g* and *k*; in *ps* the *p* is mute in words derived from Greek, and the sound of *v* is lost at the end of a word when preceded by *l* or *r*. Diphthongs are: *ai, ei, oi, ui, øi, au, eu, and ou*. The first two are pronounced like *i* in *lie*; *oi* like the English *oy*; *ui* like the English *e*; *øi* very nearly like *oy*; *au* like *ou* in *house*; *eu* like the French *eu*, with a final sound of a *v*; *ou* as in *brought*. The accent rests mostly on the root syllable, except when the word begins with *gjen, mis, sam, u, und, or ran*, or ends in *eri, inde, agtig, or ere*.—Two genders are distinguished: *fælleskjøn*, common, and *intetkjøn*, neuter; only the personal pronoun of the third person and a few suffixes have separate forms for the masculine and feminine genders; four fifths of the nouns in the language are common, and only the names of countries, cities, metals, letters, languages, clothing material, and a few others, are *intetkjøn*. The definite article of a noun preceded by an adjective is *den* in *fælleskjøn*, *det* in *intetkjøn*, and *de* in the plural of both genders; thus: *det skønne Land*, the fine country; *den*

*gamle Stol*, the old chair; plural, *de gamle Stole*. When there is no adjective it is suffixed to the noun, after dropping the *d*; thus: *Land-et*, *Stol-en*, the country, the chair; but it is *ne* or *ene* in the plural, as *Lande-ne*. The indefinite article, derived from *eet*, *een*, a, one, is *et*, *n*, *en*; e. g.: *et Land*, a country, *en Stol*, a chair. The nominative, dative, and accusative cases cause no change in the noun; there is only the suffix *s*, *es* for the genitive of both numbers. The plural is formed in three ways, viz.: by suffixing *e*, as *Land-e*; or by *er*, as *Sag*, thing, *Sag-er*, things; or by leaving it unchanged with the exception of the radical *a* and *o*, which assume the forms of *æ* and *ø* in many nouns of the three declensions, as *Barn*, child, *Børn*, children; *Bog*, book, *Bøger*, books. Adjectives not preceded by the article or preceded by the indefinite article remain unchanged in *fælleskøn*, and receive *t* in *intetkøn*, singular, and *e* in the plural of both genders; but when they are preceded by the definite article they receive *e* in both genders and numbers; thus: *god Dreng*, good boy, *en god Dreng*, a good boy, *gode Dreng*, good boys, *den gode Dreng*, the good boy, *de gode Dreng*, the good boys; *stor*, large, *stort Bord*, a large table, *store Borde*, large tables. The comparative degree is formed by adding *re* or *ere*; the superlative by *ste* or *este*; e. g.: *et lærdere Fruentimmer*, a more learned woman; *den hvideste Farve*, the whitest color. Some of the irregulars are: *ung*, *ynge*, *yngst*, young, younger, youngest; *lille*, *mindre*, *mindst*, little, lesser, least; *megen*, *mere*, *meest*, much, more, most; *mange*, *flere*, *fleest*, many, more, most; *god*, *bedre*, *bedst*, good, &c.; *ond* or *slem*, *værre*, *værst*, evil or bad, worse, worst; *gammel*, *ældre*, *ældst*, old, &c.; *nær*, *nærmere*, *nærmest*, near, nearer, next; *ydre*, *yderst*, utter, utmost, &c. The numerals are: *eet*, *een*, 1; *to*, 2; *tre*, 3; *fjre*, 4; *fem*, 5; *sex*, 6; *syr*, 7; *otte*, 8; *ni*, 9; *ti*, 10; *elleve*, *tolv*, *tretten*, *fjorten*, &c.; *tyve*, 20; *een og tyve*, 21; *to og tyve*, 22; *trediv*, 30; *fyrgetyve*, 40; but the following four decades are peculiar: *halvtreds* or *halvtredsindstyve* (half 60 and 20) for 50; *treds* or *tredsindstyve* (3 times 20), 60; *halvfjreds* or *halvfjredsindstyve* (half 80 and 20, only equal to 60), used for 70: *fjirs* or *fjirsindstyve* (4 times 20), 80; *halvfems* or *halvfemsindstyve*, 90; *hundrede*, 100; *tusende*, 1,000. *Treds*, *fjirs*, and *fems* being taken for 60, 80, 100, supposing them to be doubled, the *halvtreds*, *halvfjreds*, and *halvfems* are taken for 50, 70, and 90, as the decades half way toward 60, 80, 100. The ordinals are: *det*, *den første*, the first; *det andet*, *den anden*, the other; or second; *den tredje*, the third; *den fjerde*, the fourth; *den sjette*, the sixth; the rest are formed by suffixing *ende*, or *nde* when the number ends in *e*, or *de* when it ends in *en*. Time (French *fois*) is *Gang*, as *anden Gang*, the second time, *ni Gange*, nine times, &c. The personal pronouns are: *jeg*, I; *mig*, me; *du*, thou; *dig*, thee; *han*, he; *hun*, she; *hans*, his; *hendes*, (of) her; *ham*, him; *hende*, her;

*vi*, we; *vores*, ours; *os*, us; *I*, you; *eders* (*jer*), yours; *eder* (*jer*), you; *Dem*, yourself; *sig*, himself, herself, themselves. The demonstratives *de*, *deres*, *dem*, are used for they, their, them. *Selv*, self, selves; but *hanselv*, himself, means also master of the house, *husselv*, herself, the house-lady, &c. The possessives are: *mit*, *min*, plural *mine*, my, mine; *dit*, *din*, *dine*, thy, thine; *sit*, *sin*, *sine*, its, his, her, their; *vort*, *vor*, *vore*, our, ours; *jert*, *jer*, *jere*, your, yours. The demonstratives are: *det*, *den*, genit. *dets*, *dens*; plural *de*, *dem*, genit. *deres* (also used in conversation with one or more persons, like the German *Sie*, *Ihnen*, *Ihr*, you, your); *dette*, *denne*, *disse*, this, these; *hiint*, *hiin*, *hine*, that, those; *suadant*, *saadan*, *saadanne*, and *sligt*, *slig*, *slige*, such. The relatives are: *der*, who; *som*, who, whom, that; and the interrogatives: *hvo*, who? *hvad*, what? *hvilket*, &c., which? Indefinite pronouns: *der*, it, there, also with passive verbs; *man* (also German, the French *on*), one, some one; *noget*, *nogen*, plural *nogle*, some, any; *somme*, some people; *intet*, *ingen*, nobody; *alt*, *al*, plural *alle*, all; *hvert*, *hver*, *enhver*; *ethvert*, every; *hinanden*, each other; *hverandre*, one another. The theme of the verb is the imperative; the conjugation comprehends two orders subdivided into three classes each, according to the form of the past tense.

#### I.—SIMPLE ORDER (present and past indicative, and participle past).

- 1st conj. { 1. *Klager*, complain, *klagede*, *klaget*.  
2. *Brænder*, burn, *brændte*, *brændt*.  
3. *Følger*, follow, *fulgte*, *fulgt*.

#### II.—COMPLEX ORDER.

- 2d conj. { 1. *Beder*, beg, *pry*, *bød*, *bedet* or *bedt*.  
2. *Faar*, receive, *fik*, *faaet*.  
3. *Lader*, load, *lød*, *laadet*.  
3d conj. { 1. *Slipper*, escape, *slip*, *slap* (plur. *sluppe*), *sluppet* or *sluppen*.  
2. *River*, tear, *rip*, *rev* (plur. *reve*), *revet* or *reven*.  
3. *Byder*, offer, *bød* (plur. *bude*), *budet* or *budt*.

Person and number are distinguished by pronouns or other words; the numbers of verbs are often alike, and are confounded in common speech, though distinguished in writing. The passive voice admits of no distinction of numbers or persons in the form of the verb, but merely of tenses and modes. The present and past tenses are formed by means of the suffix *s* or *es*; thus: *Jeg elsker*, I am loved; *jeg elskedes*, I was loved (from *jeg elsker*, I love; *jeg elskede*, I loved or have loved). The infinitive is sometimes denoted by *at*, to; thus: *at elske*, to love; the participle present by *nde* final. There are also deponent verbs, analogous to those of the Latin. The auxiliary or periphrastic verbs are: *skal*, plural *skulle*, shall; *skulde*, should, &c.; *vil*, plural *vill*, will; *vilde*, participle *villet*, would; *har* (from *haver*), have; passive *haves*, be possessed by; *er*, am; *var*, was; *vær*, be; *faaer*, get; *maa*, may, must; *kan*, can, may; *tor*, dare, need; *lader*, let, cause to, &c. *Bliiver*, become, forms the passive sense; e. g.: *bliiver fundet*, is found. *Har* and *faaer* with an infinitive also

express duty: *Jeg har at sige Dem*, I have to say (to) you. The Danish has more varieties of circumlocution than the English, and its auxiliaries are less irregular. The syntax resembles that of the English. The definite article may be omitted, but it is sometimes used where the English omits it; thus: *Natur-en*, nature; *Liv-et*, life, &c. The noun which governs a genitive precedes the nominative, and usually without the article; e. g.: *Verdens Alder*, the age of the world; *et Legemes (body) Tyngde*, the gravity of a body; *mange Vandets Lyd*, of the sound of many waters. The preposition *af* is omitted with quantities, as *en Mængde Mennesker*, a crowd of people; unless the thing measured be definite, as *en Skieppe af den ny Hvede*, a bushel of the new wheat. Adjectives follow only surnames, as *Knud den Store*, Canute the Great. *De*, they, when used to address a single person, takes the singular of the verb, as *Gaaer De paa Komædie?* Do you go to the theatre? The active participle in *nde* final is never used as a gerund, but mostly as an adjective, and the English participle in *ing* must often be rendered by the infinitive; thus: *det er neppe værd at see*, it is scarcely worth (to see) seeing. Prepositions sometimes must be translated by other words; thus: *i*, in; *i Gaar Aftes* (in yester eve's), last evening; *i Morges*, this morning; *i Aar*, this year; *i Morgen*, to-morrow, &c. They are also written as adverbs: *igaar*, yesterday, *igaaer-aftes*, last night, &c. *Paa*, on, upon: *paa Søndag*, next Sunday. *Ad*, to, up, of: *ad Aare*, next year. *Om*, for, about: *5 Rigsbankdaler om Maanedens*, \$5 a month, &c. We sub-join a specimen of Danish construction:

En Ulv,	den	dummeste	af	sin	Slægt,	traf
A wolf,	the	silliest	of	his	kind,	met
engang	en	Hund	udenfor	Skoven.	Ulven	
one time	a	dog	outside	wood.	Wolf	
vilde	til	at	slæbe	denne	bort,	da
would	about	to	carry	this	one	away,
forestillede	ham	at	den	var	altfor	mager.
presented	to	him	to	he	be	too
					lean.	

For a thorough study of the Danish language the following works may be consulted: Peder Syv, *Simbriske Sprog* (1663), the Cimbric being the basis of the Danish orthography; E. Pontoppidan, *Grammatica Danica* (1668); Otho Sperling, *De Danicæ Lingvæ Antiqua Gloria* (1694); J. Baden, *Roma Danica, sive Harmonia Lingvæ Danicæ cum Latina* (1699); J. H. Schlegel on the advantages and defects of the Danish language (in Danish, 1763); Rask's grammar for Englishmen (1830 and 1846); Fradersdorff's "Practical Introduction to Danish" (London, 1860). Dictionaries: H. van Alphen, "Royal Dictionary" (in Danish, 1764-72), and *Dictionnaire français-danois et danois-français* (3 vols., 1772-36); *Dansk Ordbog* ("Danish Wordbook"), under the direction of the society of sciences, by Möller, Viborg, Thorlachus, Müller, &c. (5 vols., 1793-1825); Björn Halderson's lexicon, Icelandic,

Latin, and Danish, edited by Rask in 1814, and Danish-English, by Ferral, in 1845-'54; Hornbeck's "Danish-English and English-Danish Dictionary" (2 vols., Copenhagen, 1863).—The literature of Denmark is for the most part of recent growth. Mediæval Danish writings belong to the general literature of Scandinavia. The most important of them are the codes of the ancient kings, which belong to the 12th century, and the songs and ballads, partly derived from the Scandinavian sagas, which have been preserved by being sung by the people. The Faroe islanders still sing them, and dance to their accompaniment. The historian Saxo Grammaticus (died about 1204) wrote in Latin. He was one of the first scholars of his time, and his *Historia Danica* has been thought worthy of a modern translation into Danish and of much scholarly comment. During the union of Denmark, Sweden, and Norway under one government, from 1397 to 1523, there was not much literary progress. Learning was confined to the clergy, who wrote mostly in Latin and on scholastic themes. Even the poems and dramas of the time were scholastic or mystical allegories. The general revival of letters, however, at the time of the reformation was felt in Denmark. Pedersen's translation of the New Testament and the Psalms was incorporated into the official translation of the whole Bible made in 1550, and its influence upon the national language and literature can hardly be overestimated. Pedersen also wrote some popular histories which were widely read. Unhappily the majority of writers in the 16th and 17th centuries were confined to dogmatic and ecclesiastical discussions, and the government, having adopted the Lutheran faith, persecuted any deviation from it; yet the eminent names of Tycho Brahe, the great astronomer, and Thomas Bartholin, the first anatomist of his day, with a number of others, including Christian Longomontanus and Ole Römer, placed Denmark in the first rank of scientific progress. In this period there were also several students of earlier Scandinavian history, Arent Berndtsen (died in 1680) being the most eminent of them, whose writings are of great value to the modern student; while the collection of the early popular songs, especially the work of A. S. Vedel (1591), gave a strong impulse to national poetry. It is said that Sophia, queen of Frederick II., when on a visit to Tycho Brahe, was detained several days by stormy weather; the astronomer beguiled the time by reading to her from Vedel's collection, and the queen was so delighted with the work that she provided for its publication. Vedel was followed a century later, and his collection enlarged, by Peder Syv. The 17th century also produced some original poets, three of whom should be named: Anders Arreboe (1587-1637), whose *Hexameron* describes the six days of creation; Anders Bording (1619-1677), who by royal privilege edited the "Danish Mercury," a political sheet published

monthly, and written throughout in verse; and Thomas Kingo (1634-1723), the author of many excellent hymns. Arreboe is called the father of Danish poetry. The poets and prose writers of the 16th and 17th centuries are enumerated by Thura in his *Idea Historiæ Literariæ Danorum* (1732). The classic mythology never pervaded the literature of Denmark, as it did that of other European countries; and hence the modern development of Danish poetry has a strongly Scandinavian character, the poets drawing their inspirations less from Greece and Rome than from the Scandinavian sagas, brought out by the labors of Vedel and his successors. The chief Danish writer of the 18th century is Ludvig Holberg (1684-1754), dramatic poet, writer of fiction, and popular philosopher, whose fertile imagination and genial humor manifest themselves with a strong bracing realism. He was most at home in comedy. He founded the theatre at Copenhagen, and wrote for it within three years 20 plays, several of which still continue to be favorites. The most popular are: "The Pewter Statesman," a political satire; "The Arabian Powder," a satire upon the alchemists; "Ulysses," a parody of the heroic German drama; and "The Brothers Antipodes," representing two brothers, one superstitious and the other skeptical, both undergoing a spiritual cure. Holberg has been called the Molière of the North. His most heroic epic, "Peder Paars," in which the hero is a country grocer, shipwrecked while crossing to Jutland to meet his lady love, is full of humor and genial philosophy. He wrote a prose satirical romance entitled "Niels Klim's Subterranean Journey," of supposed skeptical tendencies, which from fear of the orthodoxy of King Christian VI. was first published in Latin (1741), but was subsequently translated into almost every European tongue. His "History of Denmark to the year 1670," also written in Latin, is a standard work. Christian Falster was a contemporary of Holberg, and wrote some satirical poems of reputation, but of unequal merit. The next poet of the first order is Johannes Ewald (died 1781). His tragedies of "Baldur's Death" and "Rolf Krage" have long been favorites, as well as his comedy "The Harlequin Patriot," while he is the author of the Danish national song "King Christian at the high mast stands." Ewald holds toward Holberg somewhat the same relation as Schiller to Goethe, and both their names are representative of the early, enthusiastic, and successful effort to establish a national literature free from foreign corruption. They were followed by Christian Pram, a poet of considerable merit, whose romantic epic *Størkodder* appeared in 1785; and Ole Johan Samsøe (died 1796), and Levin Christian Sander (died 1819), writers of excellent tragedies, who coöperated in the development of a purely national literature; while the Danish histories of Peder F. Suhm and Erik Pontoppidan stand

prominent toward the close of the century. Jens Baggesen (1764-1826) was the favorite lyricist of the nation. His tales, lyrics, and comic epics are full of grace and humor. He was an admirer of the German poets, and wrote and published a number of pieces in German. He may perhaps be considered as marking that inclination toward German associations which comes out more conspicuously in Adam Oehlenschläger (1779-1850), the greatest Danish poet of the present century. Oehlenschläger found his favorite subjects in the mythology of Scandinavia, and his "Baldur the Good" and "Gods of the North" bring the gods of the Edda and the old Norse heroes upon the modern stage. His "Correggio" is an exquisite picture of the representatives of different schools of painting, and became a favorite of the European stage. The "Death of Socrates" and "Queen Margaret" show rich fancy, tender pathos, and noble diction. His "Hamlet" gives not the Shakespearian but the historic character as handed down by Saxo Grammaticus; its first representation in Copenhagen (1846) excited the greatest enthusiasm. Oehlenschläger translated his own works into German, and is as well known in Germany as in Denmark. Peder Andreas Heiberg (1758-1841) was a dramatic writer of great originality. His son Johan Ludvig Heiberg (1791-1860) confined himself to comedy and vaudeville, but ranks among the first of recent dramatists. He was also a philosophical and archæological writer of great merit, and his novels, published anonymously, are little if at all inferior to those of Hans Christian Andersen. Bernhard Severin Ingemann (1789-1862) was a poet and dramatist known outside of Denmark. His epics *Waldemar de Store* and *Holger Danske* deserve great praise. He is the author also of the national song *Danebrog*. Hendrik Hertz (1798-1870) is also known outside of his native land, and some of his lyrics and dramatic poems have been translated into English. Fr. Paludan-Müller (born 1809) is also eminent; his *Adam Homo*, which may be classed with epic, didactic, or satiric poetry, is perhaps the most remarkable production of modern Danish literature. Nicolai Frederik Severin Grundtvig (1783-1872) is in many respects one of the first Danish authors of recent times. As a popular writer of hymns he is unequalled; in lyrical and historical poetry he equals Oehlenschläger, his *Kong Harald og Ansgar* and *Optrin af Kämpelivets Undergang i Nord* being beautiful delineations of the old Danish life and character; while his archæological writings and his translations of the works of Snorro and Saxo are of great value. His son Svend Grundtvig (born 1824) has published investigations of the literary monuments of Iceland. Christian Molbech (1783-1857) gained great distinction in Danish literary history. In 1826 he edited Harpestræng's "Book of Medicine," supposed to have been written in the 13th century. His son Chr. Karl Frederik Molbech



(born 1821), besides being well known as a student of Norse and Danish literary history, is a distinguished lyric poet. Rasmus Christian Rask (1787-1832) is one of the greatest philologists of the present century. He also wrote on the antiquities of Iceland and on the age and antiquity of the Zendavesta, besides publishing an edition of the Edda. Among scientific writers who have contributed to the world's progress, mention should be made of Heinrich Christian Schumacher, the astronomer (1780-1850), and J. F. Schouw, the physicist and geographer (died 1852). Hans Christian Oersted (1777-1851) has a world-wide reputation as the discoverer of electro-magnetism. His best known work, *Aanden i Naturen* ("The Soul in Nature"), has been translated into all European languages. His brother, Anders Sandøe Oersted (1778-1830), is known as a writer on jurisprudence and diplomacy.—In Denmark, as in other lands, the novel takes a foremost place in the literature of the present day. The most celebrated Danish novelist of our time is Hans Christian Andersen (born 1805). His best works, however, are his short fairy tales. His imagination and humor place these among the most charming of writings, and they are translated into all European tongues. His novels are less successful, though not without merit. He has also written lyrical pieces and dramas. Other modern novelists are Steen Steensen Blicher (died 1848), who describes the customs and characteristics of the Jutland people with much beauty; Waldeemar Adolf Thisted, better known under the pseudonyme of Emanuel St. Hermidad (born 1815); and Wilhelm Bergsøe (born 1835), whose *Fra Piazza del Popolo*, published in 1866, has given him a high reputation, and whose works are promptly reproduced in other languages.—The principal works not already mentioned on the history of Danish literature are Kraft and Nyerup's *Almindeligt Literatur-Lexicon* (3 vols., 1774-84); Erslew's *Almindeligt Forfatter Lexicon* (5 vols., 1841-60); Overskov's *Den Danske Skueplads i dens Historie* (4 vols., 1859-62); and *Bibliotheca Danica*, a systematic catalogue of Danish literature from 1482, the date of the first printed book, to 1830, including Icelandic and Norwegian books (Copenhagen, 1870).

**DENNER**, Balthasar, a German portrait painter, born in Hamburg in 1685, died there, April 14, 1747. He was employed by Frederick the Great and other German princes, and was invited by George I. to England, where he met with little encouragement. His chief merit consists in the mechanical finish of his pictures, some of which require to be examined with a magnifying glass in order that the labors of the artist may be appreciated. In his head of an old woman in the gallery of Vienna the down on the cheeks and the pores of the skin are represented with scrupulous exactness. This picture was purchased by the emperor Charles VI. for 4,700 imperial florins, and the

artist was commissioned to furnish a companion piece of an old man, which is not less carefully finished. His pictures were in great request in his day and brought very high prices.

**DENNIE**, Joseph, an American author and journalist, born in Boston, Aug. 30, 1768, died in Philadelphia, Jan. 7, 1812. He graduated at Harvard college in 1790, and studied law at Charlestown, N. H., where he was admitted to the bar. He read the Episcopal service to members of that communion at Claremont, and was urged to enter holy orders, with the promise of a settlement. In 1795, having acquired some reputation by literary contributions to various newspapers, under the title of "The Farrago," he became connected with a weekly journal published in Boston, called the "Tablet." This publication survived but three months, and in the summer of 1795 Dennie removed to Walpole, N. H., and became editor of the "Farmer's Weekly Museum," which attained extensive popularity under his management. His most notable contributions were a series of essays entitled "The Lay Preacher." The articles were discursive and lively, were widely copied by the newspapers of the Union, and gave their author a high reputation as a graceful and humorous essayist. The publisher became bankrupt in 1798, and Dennie was induced to become a candidate for congress, but was defeated. In 1799 he went to Philadelphia to fill the position of confidential secretary to Timothy Pickering, then secretary of state. He remained in this office but a few months, and after editing for a short time the "United States Gazette," on Jan. 1, 1801, he commenced, in conjunction with Asbury Dickins, the publication in Philadelphia of the "Port Folio," originally a weekly, but subsequently a monthly journal, in which he adopted the editorial cognomen of "Oliver Old-school." The "Port Folio" was the vehicle of frequent communications from John Quincy Adams (whose letters from Silesia were originally published in it), Horace Binney, Judge Hopkinson, Robert Walsh, Charles Brockden Brown, and other literary men, and maintained for many years a high reputation. He continued to be connected with the "Port Folio" until his death, and was highly esteemed for his social qualities as well as for his literary abilities. He was the originator of the "Tuesday Club."

**DENNIS**, a town of Barnstable co., Mass., on Cape Cod, about 65 m. S. E. of Boston; pop. in 1870, 3,269. It extends entirely across the peninsula, here 8 m. wide, and is separated from Yarmouth by Bass river. It contains a number of churches and schools. Most of the inhabitants are engaged in commerce, ship building, and fishing. About 50 vessels are annually employed in cod and mackerel fishing, and 80 or 90 in the coasting trade. The Cape Cod railroad passes through the town.

**DENNIS**, John, an English writer, born in London in 1657, died Jan. 6, 1734. He was the

son of a saddler, but was sent to Harrow school and Cambridge university, where he remained eight years, taking his degree of A. M. in 1683. After travelling some time on the continent he returned, a whig in politics, and mingled with the politicians and literary men of London. Among his friends were Dryden, Halifax, Wycherley, and Congreve. By his expensive habits he soon dissipated a small fortune which had been left him, and the duke of Marlborough obtained for him an appointment in the customs worth £120 a year; but he was compelled to sell this to satisfy pressing demands, only reserving a small annuity for a term of years. Having outlived this term, he was reduced to great poverty, became blind, and was compelled in the latter part of his life to depend upon the charity of literary friends, many of whom he had grossly calumniated. He wrote some verses of little merit, and several plays which obtained a transient popularity, especially the one entitled "Liberty Asserted," in which the French, with whom the English were then at war, were roughly handled. Of his essays the best are "The Grounds of Criticism" and those on Addison's "Cato" and Pope's "Rape of the Lock," though the two latter are characterized by the bitterness with which he usually spoke of his contemporaries. He attacked Swift, Pope, Addison, Steele, and nearly all the prominent writers of the day, thereby making enemies of those best able to castigate him. This was done most effectually by Swift and Pope, the latter devoting to him some of the sharpest hits in the "Dunciad." He had a most exaggerated idea of his own importance, and desired to have a clause in the treaty of Utrecht protecting him from the wrath of the French king, which he imagined had been aroused by his play, "Liberty Asserted." He had invented a new way of imitating thunder for his play of "Appius and Virginia," which was brought out and failed in 1708. Shortly afterward, during the performance of "Macbeth," hearing the thunder produced by his apparatus, he rose in the pit and denounced the managers for stealing his thunder. His fame is due mainly to the abuse which he received from those he had assailed.

**DENON, Dominique Vivant**, baron, a French archaeologist, born at Châlons-sur-Saône, Jan. 4, 1747, died in Paris, April 27, 1825. He was sent to Paris to study law, but devoted his time chiefly to art and literature. He gained favor at the court of Louis XV., was employed on several embassies, and after the death of that king was for a time minister to Switzerland. Going subsequently to Naples in the suite of the ambassador, he spent several years in Italy, studying the monuments of ancient art, forming collections of remarkable specimens, and making copies of others. Here also he studied etching and mezzotint engraving. He engaged with the abbé de Saint-Non to superintend the preparation of a *Voyage pittoresque de Naples et Sicile*; but

having a dispute with him, he brought out the work independently. The portion relating to continental Italy appeared in the notes to a French translation of the journey of Swinburne, and that relating to Sicily and Malta in a separate volume. Having returned to Paris during the revolution (after a second stay in Italy), he met Bonaparte at the house of Mme. de Beauharnais, and was chosen by him to accompany the expedition to Egypt in the capacity both of a savant and artist. In 1802 appeared his *Voyage dans la basse et la haute Égypte*, profusely illustrated by his own hand. It was first published in two large folio volumes, but there are several editions of smaller size. He also took the chief part in the preparation of the *Description de l'Égypte*, under the auspices of the Egyptian institute, of which he was a member. Bonaparte made him inspector general of the museums of France, and he accompanied the army in the various campaigns of the emperor, selecting the works of art which were gathered to enrich the galleries of the Louvre. On the second restoration he retired to private life, and spent some years in collecting and arranging the material for a history of art, which was finished by Amaury Duval (*Monuments des arts du dessin chez les peuples tant anciens que modernes*, 4 vols. fol., 1829). Denon's own etchings number more than 300.

**DENT**, a S. E. county of Missouri; area, about 750 sq. m.; pop. in 1870, 6,357, of whom 31 were colored. The soil is fertile and the surface much diversified. Current river and several smaller streams have their sources here. The chief productions in 1870 were 55,024 bushels of wheat, 215,693 of Indian corn, 53,042 of oats, 16,539 of potatoes, 988 tons of hay, 58,588 lbs. of butter, and 26,770 of tobacco. There were 1,241 horses, 1,547 milch cows, 3,426 other cattle, 6,861 sheep, and 11,230 swine. Capital, Salem.

**DENTALIUM**, or **Tooth Shell**, a gasteropod mollusk, usually placed near the limpets. The shell is tubular, symmetrical, curved like a long slender tooth, open at each end, attenuated posteriorly; the surface is either smooth or longitudinally striated; aperture circular. The animal is attached to the shell near the posterior anal surface; head rudimentary, without eyes, with teeth in mouth at the base of a long, conical foot; there are two symmetrical branchiæ; sexes believed to be united. In the early stages they have wing-like expansions at the anterior part of the body, and many tentacles around the head. They are animal feeders, devouring minute bivalves and foraminifera; they are all marine, living in almost all seas, on sandy and muddy bottoms, in which they often bury themselves; they are found in from 10 to 100 fathoms. There are about 50 living and 125 fossil species, ranging from the Devonian forward. They were classed by the early zoölogists with the worms, and even Cuvier placed them near

*serpula* among the annelids, noticing, however, certain characters recalling the molluscan structure. This shell has recently been brought into notice by Prof. E. S. Morse, who

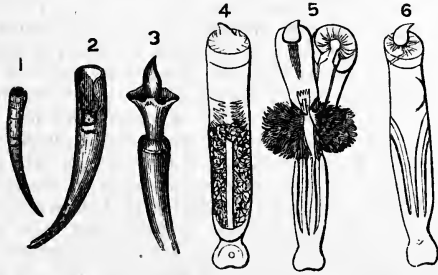

1. Shell of *Dentalium entalis*. 2. Shell magnified and fractured, showing animal contracted. 3. Animal at the moment of advancing from the shell. 4. Animal magnified, abdominal aspect. 5. Animal magnified and cut open, showing internal formation. 6. Animal magnified, dorsal aspect.

has found in it many different characters interesting from a Darwinian point of view, and suggesting the development of the branch of mollusks from dentalium or some animal resembling it, which had been derived from some annelid form. *Dentalium*, according to him, points to the acephala in the absence of a head, to the gasteropods by the lingual teeth, to the pteropods by the wing-like expansions, and to the cephalopods by the many tentacles of the embryo. Whether these indicate derivation or not, the union of annelid peculiarities with those of all the classes of mollusks is certainly unusual and interesting. The common species of the Atlantic, the *D. entalis* (Linn.), is about  $1\frac{1}{2}$  inch long and  $\frac{1}{4}$  inch in diameter at the anterior end, tapering to a dull point.

**DENTATUS, Manius (or Marcus) Curius**, a Roman consul, flourished in the first half of the 3d century B. C. In 290 he became consul and defeated the Samnites; in 275, during his second consulship, he vanquished Pyrrhus in two great battles; in 274 he was elected consul a third time, and was victorious over the Samnites, Lucanians, and Bruttians. On the conclusion of his third consulship he retired to a small farm in the Sabine territory, and cultivated it with his own hands. While he was thus engaged, the Samnites sent an embassy to him with costly presents. They found him sitting at the hearth cooking vegetables for his dinner. He rejected their gifts, telling them he would rather rule over those who possessed wealth than possess it himself. In 272 he was made censor, in which capacity he constructed an aqueduct from the Anio (Teverone) into the city, and by a canal he carried off the water of the lake Velinus (Velino) to the Nar (Nera), and thus gave to the Reateans a large tract of excellent land. He is said to have been born with teeth; hence his surname of Dentatus.

**DENTISTRY** (Lat. *dens*, tooth), the surgical treatment of the teeth, and the manufacture and fitting of artificial teeth. Although it is

only within less than a century that dentistry has taken the rank of a distinct profession, attention was directed from the earliest periods to the means of preserving and improving the beauty of the teeth. In the time of Herodotus dentistry appears to have been practised in Egypt as a distinct branch of surgery, as was also the treatment of the diseases of the eye and of the ear. Little, however, is known of the attainments of these early practitioners. In the ancient tombs of this people artificial teeth of ivory or wood were found by Belzoni and others, some of which were fastened upon gold plates. It is also stated that teeth of the mummies have been found filled with gold. Thus it would seem that the ancient Egyptians understood processes of the art which are commonly regarded only as inventions of modern times. Artificial teeth are alluded to by several of the Greek and Latin poets, as Ovid, Martial, and Horace. The works of Galen, written in the 2d century, contain the earliest treatises upon this subject, and they continued to be the best until the works of Fallopius, Eustachius, and Ambroise Paré appeared in the 16th century. During the 18th century the attention of many medical men in France and England was directed to the subject, and a number of elaborate works were published devoted exclusively to the art of dentistry. These, and prominently among them the treatise of John Hunter (1771-'8), laid the foundation of the English school of dentistry. The subject, however, was treated anatomically and philosophically rather than practically; and the same may be said of the writings of the eminent French surgeon of this period, Bichat. Neither of these was a practical dentist, and the subsequent publications of Dr. Blake in 1798, and of Fox in 1803 and 1806, as of others at later dates, served rather to elucidate the physiology of the teeth and the nature of the diseases to which they are subject than the method of treating them. From advertisements in the newspapers of 1803 the practice of making teeth and cleaning them appears to have been in the hands of silversmiths or jewellers. In 1826 the "Principles of Dental Surgery," by Leonard Koecker, M. D., who had practised dentistry from 1807 to 1822 in Baltimore and Philadelphia, appeared in London, and fully established the claims of the art to take rank as a distinct branch of science. From that time new treatises have continued frequently to appear. The progress of the French school was very rapid in the early part of the present century. Prof. Baumes's treatise on first dentition and the diseases that accompany it appeared in 1805, and about the same time a work on the theory and practice of the art by Laforgue. A number of works were published by Delabarre between 1815 and 1826 on different subjects relating to the teeth and their treatment. Among them is a treatise on "Mechanical Dentistry," published in 1820, and illustrated with 42 plates.

It was during this period, when publications upon dentistry were frequently appearing in France, that the manufacture of artificial teeth of porcelain was introduced; and in 1821 a work upon this subject was published by Audibran, entitled *Essai historique et pratique sur les dents artificielles incorruptibles*. By this it appears that Fauchard in 1728 proposed their manufacture; and that in 1776 Duchateau, a chemist of St. Germain-en-Laye, attempted to produce them, and finally succeeded with the aid of Dubois, a dentist of note in Paris. The latter imitated the colors of the natural teeth and gums by the use of mineral oxides, and obtained royal letters patent for the invention. Dentistry was introduced into the United States by Le Mair, of the French forces which joined our army during the revolutionary war. An Englishman named Whitlock also commenced the practice soon after the arrival of Le Mair. About 1788 John Greenwood established himself in New York, the first American of this profession. In 1790, and again in 1795, he carved in ivory an entire set of teeth for Gen. Washington. They were secured by spiral springs, and the neatness and ingenuity of the work was considered equal to any executed at that period abroad. Other dentists soon appeared in New York, Philadelphia, and Baltimore. Their work included the extracting of teeth, filing and cleaning them, and replacing the natural teeth when lost with artificial ones, commonly made of ivory. Dr. Hudson, formerly of Dublin, who had settled in Philadelphia, first directed his attention particularly to the cure of the diseases of the teeth, and to arresting the progress of dental caries. In 1820 the number of practitioners in the United States was probably little more than 100. Ten years afterward there were about 300, of whom probably not more than one sixth were well instructed. But the increase in their numbers was afterward very rapid. In 1842 they were believed to number about 1,400, and in 1872 about 5,000. An important event in the history of dental surgery in this country was the establishment of the "American Journal and Library of Dental Science" in Baltimore, in 1839. The society of dental surgeons was soon after formed, and at its second annual meeting the "Journal" was made the property and organ of the association. Maryland founded by its legislature, a few months previous to the organization of the society above named, a college of dental surgery, with four professorships, designed for instruction in the principles and mechanical practice of the art. Two years afterward another society of dentists, like that of Baltimore, was organized at Richmond, Va., and in August, 1844, a third was formed at Cincinnati, Ohio, styled the "Mississippi Valley Association of Dental Surgeons." A college of dentistry has also been established in Philadelphia and another in Cincinnati, and state and local dental societies in various parts of

the country. In August, 1855, the national convention of dentists was organized through the active exertions of Dr. Elisha Townsend of Philadelphia, and its first annual meeting was held in that city. Dr. John B. Rich of New York was its first president. Besides the reports of these societies, which have disseminated a knowledge of the discoveries and improvements made in the science, many very valuable works of a practical nature have been published by American authors.—The means of preventing the diseases to which the teeth are subject, is a branch of dental science quite as important as that relating to the arrest and cure of these diseases. These means consist, first, in giving what assistance nature requires to bring the teeth of second dentition into a regular arrangement; and secondly, in the care of the individual himself in preserving the teeth uniformly clean. As the temporary or first set of teeth drop out, which as a general rule they should be allowed to do, by their roots being absorbed, the second set already formed succeed and take their places. Of the temporary teeth there are but 20, and these are of small size. The teeth of the second dentition are 32 in number, with one or two exceptions are of larger size than their predecessors, and consequently occupy a greater space. Yet these, appearing one by one, take their places, and should occupy in the harmonious process of the growth of all the parts the same room apparently that was filled by the 20 deciduous teeth. This is accomplished by the elongation forward of the jaw, the arch gradually assuming the form of a semi-ellipse in place of that of a semi-circle. Teeth irregularly arranged, interfering with each other, or as in some cases with the lips, or pointing inward so as to be removed from the healthy action of mastication, or twisted in their sockets, are not only disfiguring, but are particularly liable to disease and decay. From their first appearance to the age of 16 of the individual, they may be treated by various mechanical applications attached to the other teeth and bearing suitably upon those to be brought into place, so that without violence the work of nature is gently assisted, and a perfect set is gradually formed. It is the opinion of dentists that when the teeth are kept perfectly clean they will not be affected by caries. As the secretions of the mouth are, however, liable to be vitiated by constitutional disorders, the keeping them clean requires great vigilance. When caries occurs it should be immediately removed by the use of the file. The surface of the bone from which the enamel is removed should be left smooth and polished, and if proper care be afterward taken in keeping it clean, the disease may not return. If the decay has extended into the bony substance of the tooth, the filing is then only preparatory to the complete removal of the diseased portion by excavating with suitable instruments, and filling the cavity with some proper material. Much

attention was formerly given to shaping the cavity, in order that by its contracted aperture the filling should be held in as by dovetailing; but by the use of gold foil and sponge gold specially prepared for this purpose, it is now found practicable to apply the metal in successive portions, and build up a solid block of any shape by incorporating each portion with that which preceded it. This is done by carefully packing it with suitable instruments, and the gold may be thus rendered so compact, it is affirmed, that its specific gravity shall equal that of the cast metal. In wide-mouthed cavities the filling is secured by being built upon plugging carefully introduced into the cavities of the roots, and also by lateral pins of the gold filling made to enter from this into little holes or grooves drilled for the purpose into the walls of the tooth. It has been generally considered impracticable to preserve a tooth when the decay has reached into the internal or pulp cavity. In this condition inflammation often takes place at the root, and matter collects, forming an ulcer between the periosteum of the tooth and the bone. If the discharge of this be stopped by filling the cavity, the matter will find its way through the gum, causing a gum boil near the root; or it produces inflammation of the face, often attended with great suffering, which is relieved only by the removal of the tooth. The modern treatment is to perforate the sac at the root by a fine drill passed through the cavity; and if the pulp be sensitive, it is cut out and removed by a delicate steel wire furnished with a hook at the end, so small that it can pass freely into the nerve cavity. A solution of creosote or carbolic acid is then injected into the cavity, and as soon as a healthy action has taken place the tooth may be safely filled, with the liability of further trouble from the same cause greatly reduced.—The only unobjectionable material for filling teeth is gold foil or the sponge gold specially prepared for this purpose. The latter material is produced by dissolving gold free from copper in nitro-hydrochloric acid, placing the solution in a flat-bottomed vessel, and heating and precipitating by strong solution of oxalic acid. In a few hours the gold is wholly deposited, and the supernatant liquid may be decanted off, taking care not to disturb the gold at the bottom. The vessel is then several times filled with boiling water and decanted, until the last washings contain no more oxalic acid. The gold is now carefully slipped upon a piece of filtering paper, and by means of a spatula gently pressed into the form of the desired cake, but a little thicker. It is then removed to a porcelain crucible, and heated for a short time, somewhat below a red heat, when it shrinks and becomes coherent. Tin foil may be used, and its malleability and cheapness well adapt it for large and badly shaped cavities and for temporary fillings in sensitive teeth; but it is liable to oxidize and produce discoloration. Temporary fillings, for the

purpose of protecting the cavity while it is being prepared for gold filling, are often made of gutta percha. A preparation of it known as Hill's stopping, made by incorporating with it a powder made of quicklime, quartz, and feldspar, is highly recommended. When this composition is used a condensing instrument large enough to cover the filling should be held upon it until the nerve becomes cool. A mixture of chloride and oxide of zinc, called oxychloride of zinc; or *os artificiel*, has lately been much used as a temporary filling, and also for pulp cavities. Exposed nerves have also been covered with it, and gold used to complete the filling. The operations for filling teeth are varied and complicated. Many ingenious machines have been lately introduced for preparing cavities and condensing the filling. Drills worked by treadles, and also by galvanism as a motor force, and automatic mallets have been successfully applied.—The extraction of the teeth is an important branch of dental practice; safe and easy with good instruments in skilful hands, but, as practised by the unprofessional operator, not a little hazardous. The improved instruments of modern times, however, have greatly lessened this risk, and pain is avoided by the use of anæsthetic agents.—The last department of dentistry to be noticed is the construction and application of artificial teeth. These were formerly carved from ivory of the tusk of the elephant or the tooth of the hippopotamus. They were obtained also by altering the shape of the teeth of some of the inferior animals; and the crowns of human teeth were often conveniently engrafted upon the roots of the original front teeth. All these materials are objectionable from their susceptibility to the action of the fluids of the mouth; ivory soon becomes offensive from being saturated with these fluids; and all of them are liable to decay, inducing at the same time disease in the sound teeth remaining. Porcelain teeth perfectly resist the corrosive action of the fluids of the mouth, and imitate so perfectly in color and animated appearance the natural teeth, that they are often not easily distinguished from them. Various methods of securing artificial teeth in their places have been in use. So long ago as 400 years B. C. they were fastened by ligatures of flax or silk, and with wire of gold or silver, to the natural teeth that remained. In modern times metallic clasps, spiral springs, and fastenings of gutta percha and of caoutchouc have been used for this purpose; but the most perfect method is to secure the teeth, either in whole or partial sets, to a plate of gold or other metal, which is so accurately fitted to the gums that it is firmly retained by atmospheric pressure. In making an artificial set of teeth, the first object is to obtain in some hard metal an exact model of the mouth in which the plate is to be fitted. For this purpose, yellow or white wax, free from mixture of grease, and softened by warm water, is placed in a shal-

low vessel, which may be introduced into the mouth. Plaster of Paris made into paste may be substituted for the wax. The contents of the cup are firmly pressed around the gums, and, if for the upper jaw, are made to cover the roof of the mouth as well. An experienced operator thus obtains in a few minutes an exact mould of the parts to which the material is applied. The teeth, if any are present, leave their forms faithfully impressed in their true positions, and the cavities between are represented by corresponding projections in the wax or hardened plaster. The impression removed from the mouth serves to furnish a model of the jaw, which may be taken in plaster of Paris also. This is used as a pattern in moulding sand, and a cast is then obtained in any metal, as for instance zinc; and by pouring melted lead upon the zinc, which is turned over upon its face and surrounded with a brass or iron collar for retaining the lead, a mould in this metal is obtained precisely like the original one in wax. By means of the zinc cast and lead mould, the exact shape of the parts is transferred to the sheet of gold or other metal, this being placed between the two, and made, by hammering and swaging, to assume all their irregularities of surface. The fit is the more readily made if the teeth have been cut off from the plaster model before making the metallic casts. A duplicate plaster cast serves to give the position of those teeth to which the plate is to be finally fitted.—A variety of materials have been experimented upon, in which to securely imbed the bases of the teeth. Gutta percha has been used to contain them; but its texture and strength were in a short time destroyed by the action of the fluids of the mouth. It was then applied vulcanized or mixed with sulphur; and caoutchouc is employed in the same way. These prove to be important auxiliaries in mechanical dentistry, especially for temporary sets of teeth. They do not, however, readily take the colors which may be applied to more suitable substances. In 1851 the process called continuous gum was invented by Dr. John Allen, professor in the Ohio college of dental surgery. In this a silicious compound, similar in composition to that of which the teeth are made, but more fusible, is applied in the form of a paste over the fastenings at the back of the teeth, and also in the front, so as entirely to bury the ends of the teeth, as the natural ones are buried in the gums. To withstand the high degree of heat requisite for baking this upon the plate, platinum is substituted for gold. Platinum has besides the advantage of forming at a high heat a close union with the silicious compound, which is spread over the lingual side of the plate as well as over the bases of the teeth. When thoroughly dry, the work is baked at a white heat in the muffle of an assaying furnace. A new application of the paste is then made to fill all the crevices caused by shrinking, and upon this coating are made numerous ridges

and depressions with the spatula, which, when afterward covered with the coloring enamel, cause this to assume different shades of the color, and present the appearance of the natural gums. The baking is repeated, and after this the coating of coloring matter, called the gum enamel, is applied, when a third baking completes the process, by which a proper degree of hardness and a natural color are produced. The compositions used are empirical mixtures of pure silica and feldspar, with a suitable flux to produce a fusible compound, possessing sufficient strength, hardness, and permanency of character. The work can easily be repaired when broken, or alterations made when required by changes in the mouth, by building upon it more of the paste and again baking; in this way even the length of the artificial teeth can be increased and new ones introduced. In the same way the artificial processes called cheek restorers were applied by Dr. Allen, which are projecting portions built upon the artificial gums far back in the mouth, and serve to distend the cheeks when these are fallen in. The mechanical operations connected with the work have led to increased knowledge in the use of plastic compounds, and introduced improved methods of treating the metals employed.

**DENTITION.** In all the higher animals the teeth are developed directly from the mucous membrane, and are therefore, like hair, nails, feathers, &c., appendages of the skin, and form no part of the true osseous system. As early as the fifth week of fetal life, according to the observations of Prof. Goodsir, a deep, narrow groove between the lip and the rudimentary palate in the upper jaw indicates the future situation of the teeth. Within the next three weeks papillæ developed at the bottom of the groove become the germs of the future milk or temporary teeth. In the progress of development the papillæ are enveloped in open follicles, and these again are converted into shut sacs; contemporaneously with these changes, the edges of the dental groove are themselves growing, so that by the 14th week they meet, enclosing the tooth sacs. Within the sacs the papillary pulp is gradually converted into dentine, of which the body of the tooth is composed, while the enamel is probably formed by calcification of the epithelium abundantly produced from the inner surface of the sacs. As teeth are required before the jaws have attained their growth, and yet from their structure are incapable of enlarging *pari passu* with the bones in which they are placed, provision is made for a temporary set, which when they have served their purpose are replaced by the permanent teeth. As early as the 14th week minute crescentic depressions of mucous membrane may be discovered above and at the inner part of the opercula of the milk teeth; these depressions soon become converted into minute compressed sacs, which gradually sink behind and below the sacs of the milk teeth, and

in these sacs are developed the first ten permanent teeth of each jaw; the other six are developed in sacs placed posterior to those of the last milk teeth, which are formed in a manner precisely similar to those of the milk teeth themselves. The ossification of the permanent teeth commences a little before birth with that of the first molar, and proceeds during the first three years of infancy successively in the incisors, the canines, and the bicuspid. The approach of the time for the eruption of the temporary teeth is announced by an increased secretion of saliva. In the earlier months of infancy the mouth is comparatively dry, but as the teeth shoot into the gums the mouth becomes moist and the child begins to drivle. The progress of dentition is not apparently continuous, but after the eruption of each successive pair a pause of one or two months generally follows. The central incisors commonly pierce the gum in the course of the 7th month after birth, those of the lower jaw preceding the upper ones by a short interval; between the 7th and 10th months the lateral incisors make their appearance; from the 12th to the 14th month the anterior molars, and between the 14th and 20th the canines are cut; and the first dentition is completed between the 18th and 36th months by the protrusion of the posterior molars. Both the time and the order of appearance of the first set of teeth admit of a good deal of variation, their progress being hastened or delayed sometimes six or seven months by a lateral incisor, or even a molar or canine tooth, cutting the gum before the appearance of the central incisors. The period of primary dentition is attended with increased risk to the life of the infant. During its continuance the proportionate mortality becomes much increased, and in the bills of mortality numerous deaths are ascribed to teething alone. It must be remembered, however, that at this time all the functions of the young being are in a state of great activity, and that teething is but one in a series of changes by which the infant is prepared to substitute for the milk provided by its mother, food suitable to the conditions of its future existence. In a healthy infant dentition in itself is attended with little inconvenience and no danger; when the teeth come to distend and stretch the mucous membrane lining the gums, there is probably a little tenderness and pain, some fretfulness, and perhaps slight febrile excitement; but in the absence of other causes of disease, this soon passes over. If, however, the nervous system is unduly excitable, dentition may seriously complicate other maladies. When the process of dentition is advancing normally, it should never be interfered with; when the gum is red, swollen, and painful, scarification may be resorted to with advantage, and may be repeated if necessary, the trifling loss of blood affording relief to the inflamed gum. When the tooth is evidently about to pierce the gum, if the child appears to suffer, it may be freed by cutting down to it

with the gum lancet. In cases where convulsions supervene suddenly without an evident cause, if dentition is proceeding actively and the gums are tense and swollen, the gum lancet may be resorted to. Occasionally dentition is attended with much fever and derangement of the digestive organs, while a sloughy unhealthy ulceration makes its appearance on the gum over the teeth just about to protrude, or at the edge of the gum of those which have recently been cut. In these cases the gum lancet does positive harm, while they readily yield to a properly regulated diet, and to the use of the chlorate of potash in solution, in doses of one or two grains repeated every four hours. During the earlier period of childhood a bony plate or partition separates the permanent from the fangs of the temporary teeth; as the period approaches in which the former are to replace the latter, this partition disappears, and the crown of the enlarged permanent tooth makes its way into the cavity of the temporary fang. As the permanent tooth advances, the fang of the milk tooth is absorbed, not however from any pressure exercised by the one upon the other, the two never coming in contact; and as the crown of the milk tooth falls off, the permanent tooth is ready to replace it. The first anterior or true molar usually appears at about 6½ years; about the same time or a few months later the central permanent incisors appear; the lateral ones are developed at 8, the anterior and posterior bicuspid at 9 and 10, the canines from 11 to 12, the second true molars from 12 to 13, and the wisdom teeth from 17 to 19. From the investigations of Mr. Edwin Saunders ("The Teeth a Test of Age, considered with reference to the Factory Children"), it would appear that the second dentition furnishes the best physical evidence of the age of children within our reach; in the majority of instances he found its indications coincided closely with the real age of the children, and when they failed the extreme deviation was but a year.

**DENTON**, a N. E. county of Texas, drained by two forks of Trinity river, and occupied partly by prairies and partly by vast forests called the Cross Timbers; area 900 sq. m.; pop. in 1870, 7,251, of whom 500 were colored. The chief productions in 1870 were 18,216 bushels of wheat, 173,510 of Indian corn, 41,060 of oats, 11,826 of sweet potatoes, and 674 bales of cotton. There were 6,195 horses, 2,863 milch cows, 35,220 other cattle, 5,331 sheep, and 10,200 swine. Capital, Denton.

**DENVER**, a city of Arapahoe county, Colorado, the capital of the county and of the territory, situated on the right bank of the South Platte, at the junction of Cherry creek, 15 m. from the E. base of the Rocky mountains, and about 500 m. W. of the Missouri river, 5,267 ft. above the sea; pop. in 1870, 4,759; at the beginning of 1873 estimated by the secretary of the board of trade at

15,000. It occupies a series of plateaus rising by gentle ascents from the river, and faces the mountains, commanding a grand and beautiful view. It is built principally of brick, manufactured in the vicinity. Five railroads meet at this point, viz.: the Kansas Pacific, the Denver Pacific, the Colorado Central, the Boulder Valley, and the Denver and Rio Grande. Denver is the commercial centre of Colorado and the adjacent country, and its trade is important. The receipts of freight for 11 months ending Nov. 30, 1871, over the Denver Pacific and Kansas Pacific railroads, amounted to 62,551,690 lbs. For the same period of 1872 they were 88,539,710 lbs., of which 27,390,560 were agricultural, 5,091,640 animal, 5,138,550 forest, and 1,759,710 mining products, 8,456,060 manufactures, and 22,630,760 miscellaneous. The amount of freight shipped over these lines for the same period in 1871 was 7,031,842 lbs.; in 1872, 17,833,620 lbs., of which the principal items were as follows: grain, 1,220,560 lbs.; flour and meal, 284,720; cattle, 8,532,200; beef and pork, 232,790; hides and wool, 1,669,120; coal, 605,600; ore, 3,111,270 lbs. The arrivals of passengers in 1872 were 11,250; departures, 6,794. The shipments of coin and bullion by express during the year amounted to \$1,295,411, viz.: gold bullion, \$1,212,934; silver bullion, \$19,760; gold coin, \$62,717. The sales of merchandise in 1872 were in the aggregate \$13,039,000. The value of manufactures was \$1,394,000. The most important establishments are 6 breweries, 1 woollen mill, 3 flour mills, 1 iron foundry, 2 planing mills, 1 terra cotta foundry, several carriage factories, and a turning shop. The Denver smelting and refining works, in process of construction, will occupy a brick building 55 ft. wide by 200 ft. long, with capacity for 40 tons of ore a day. There are three national banks with an aggregate capital of \$400,000, and deposits, Dec. 27, 1872, amounting to \$1,215,570 65, and a savings bank. The branch of the United States mint is employed in the melting and assaying of bullion, which is returned to depositors in the form of bars with the weight and fineness stamped upon them. The aggregate deposits of domestic gold to June 30, 1873, were \$6,357,275 49 of which \$5,761,487 29 were from Colorado; the product was \$6,451,213 08 in gold bars, and \$19,879 43 in silver bars. The number of deposits of gold and silver in 1872 was 1,741, valued at \$1,007,529 45. The city is divided into four wards, and governed by a mayor and eight aldermen. It is supplied with water through 8 m. of pipe, and is lighted with gas. The value of taxable property in 1871 was \$6,772,908; at the close of 1872 it exceeded \$8,500,000. There are 31 hotels and a theatre. The following are the statistics of the public schools for the year ending Sept. 30, 1871: number of persons of school age (5 to 21), 1,162; number of schools, 3; teachers, 14; pupils en-

rolled, 982; average attendance, 413. There were 6 private schools, with an average attendance of 250. A public school building has recently been erected, at a cost of about \$70,000, which will accommodate 500 pupils. The territorial library contains more than 2,500 volumes. The newspapers and periodicals published here are 4 daily, 1 semi-weekly, 4 weekly, and 2 monthly. There are 8 churches, viz.: 1 Baptist, 1 Congregational, 1 Episcopal, 2 Methodist (1 colored), 2 Presbyterian, and 1 Roman Catholic.—The first cabin was erected on the site of Denver in 1858.

**DEODAND** (Lat. *Deo dandum*, a thing to be given to God). A superstitious practice prevailed in England from the earliest time until very recently, whereby a chattel which had been the immediate instrument or cause of death to a human being was forfeited to the king, to be applied by him to pious uses. *Omnia quæ movent ad mortem sunt Deo danda* (all things which are the moving cause of death are to be offered to God), is the rule stated by Bracton. It is supposed by Blackstone that the origin of this practice was the religious doctrine of making expiation for the souls of such as were carried off by sudden death. A singular distinction was made between an infant and an adult, viz.: that an infant falling from a cart or horse not in motion, there was no forfeiture; whereas in the case of an adult the horse or cart was a deodand. Yet if a horse or other animal should of his own motion kill either an infant or adult, or if a cart should run over him, in either case the animal or cart was forfeited as a deodand. Another rule equally inexplicable was, that when a thing not in motion was the occasion of a man's death, only that part which was the immediate cause was forfeited; but if the thing was in motion, then the whole was forfeited; as, if a man was run over by a cart wheel, the whole cart was a deodand. It made no difference although the owner of the chattel was not in fault. The law of deodand was not applied in cases of felonious homicides, and it is now abolished by statute 9 and 10 Victoria, c. 62.

**D'ÉON, Chevalier.** See ÉON.

**DE PEYSTER. I. Johannes**, one of the early settlers of New Amsterdam (now New York), born in Haarlem, Holland, in the beginning of the 17th century, died in New York about 1685. He was of a French Huguenot family, filled several offices under the Dutch government in New Amsterdam, and was one of the last to take the oath of allegiance to the British crown. He was subsequently at different times alderman, deputy mayor, and mayor. At his death he was one of the richest citizens in the colony. **II. Abraham**, eldest son of the preceding, born in New York (then New Amsterdam), July 8, 1658, died there, Aug. 10, 1728. He was a merchant, and amassed considerable wealth. Between 1691 and 1695 he was mayor of New York, and subsequently became chief justice of the



province, and president of the king's council, in which latter capacity in 1701 he acted as colonial governor. He was also colonel of the forces of the city and county of New York, and treasurer of the provinces of New York and New Jersey. He was the intimate friend of William Penn, and of the colonial governor, the earl of Bellamont. The mansion erected by him in Pearl street in 1695, which was at one time the headquarters of General Washington, remained standing till 1856. **III. Arent Schuyler**, a loyalist officer, grandson of the preceding, born in New York, June 27, 1736, died at Dumfries, Scotland, in November, 1832. He entered the 8th or king's regiment of foot in 1755, served in various parts of North America under his uncle, Col. Peter Schuyler, and commanded at Detroit, Michilimackinac, and various places in Upper Canada, during the American revolutionary war. It was through his efforts that the Indians were allied with the British during the war. Having risen to the rank of colonel, and commanded his regiment for many years, he retired to Dumfries. He was on terms of friendship with Burns, who addressed to him one of his fugitive pieces, and with whom he once carried on a poetical controversy in the columns of the "Dumfries Journal." At his death he had held the king's commission upward of 77 years, and was probably at the time the oldest officer in the service. **IV. John Watts**, an American military and historical writer, born in New York, March 9, 1821. He was commissioned as brevet major general by the New York legislature, and has published "Life of Gen. Torstensen" (1855), "The Dutch at the North Pole and the Dutch in Maine" (1857), "Early Settlement of Acadia by the Dutch" (1858), "The Dutch Battle of the Baltic" (1858), "History of Carausius" (1858), "The Ancient, Mediæval, and Modern Netherlanders" (1859), "Winter Campaigns the Test of Generalship" (1862), "Practical Strategy" (1863), "Secession in Switzerland and the United States compared" (1864), and "Decisive Conflicts of the late Civil War" (1868).

**DEPOSITION**, in law, the testimony of a witness reduced to writing in due form of law, taken by virtue of a commission or other authority of a competent tribunal. When taken by commission, depositions are usually in answer to questions upon the examination in chief, and upon cross-examination, prepared and submitted to the court from which the commission issues. In other cases they are taken by consent of counsel or in due course of law, the privilege of cross-examination being always preserved, except in some cases where depositions of matters within the knowledge of persons of great age are allowed to be taken for the purpose of perpetuating their testimony, and in cases where immediate death by violence is expected. This must, when possible, be sworn to and signed by the witness. In the United States, compulsory process is usually allowed to procure this evidence.—In ecclesiastical

law, deposition is the act of depriving a clergyman by a competent tribunal of his clerical orders, in punishment of some offence, and to prevent his acting in his clerical character.

**DEPPING, Georges Bernard**, a miscellaneous writer, born at Münster in Westphalia, May 11, 1784, died in Paris, Sept. 5, 1853. He went to Paris in 1803, and during the rest of his life was engaged in writing books on a variety of subjects and preparing articles for various periodicals and cyclopædias. Among his works were two juvenile books which obtained great popularity, and were translated into several languages: *Les soirées d'hiver, ou entretiens d'un père avec ses enfants sur le génie, les mœurs et l'industrie des divers peuples de la terre* (2 vols., 3d ed., 1832), and *Merveilles et beautés de la nature en France* (2 vols., 1835). He assisted Malte-Brun in his geographical works, and wrote descriptive sketches of Switzerland, Greece, England, and other countries. His most important historical works are: *Histoire générale de l'Espagne* (2 vols., 1811); *Histoire des expéditions maritimes des Normands et de leur établissement en France au dixième siècle* (1826); *Histoire du commerce entre le Levant et l'Europe, depuis les croisades jusqu'à la fondation des colonies d'Amérique* (2 vols., 1832); *Les Juifs dans le moyen âge* (1834); and *Histoire de la Normandie sous le règne de Guillaume le Conquérant et de ses successeurs* (2 vols., 1835). Several of these have been translated into other languages. He also wrote several books of travel, made various translations, edited the *Romancero castellano* and other works, contributed to the *Biographie universelle* and the *Encyclopédie portative*, and published an autobiography in German entitled *Erinnerungen aus dem Leben eines Deutschen in Paris*. An account of his life and works, by Alfred Maury, was published in Paris in 1854.

**DEPTFORD**, a town and naval arsenal in Kent and Surrey, England, on the right bank of the Thames, at the mouth of the Ravensbourne, on the Croydon and Greenwich railways, and at the junction of the Croydon and Surrey canals, 3 m. S. E. of London bridge, and contiguous to Greenwich; pop. about 40,000. It contains a royal naval school incorporated in 1840, and two ancient hospitals for decayed pilots and shipmasters or their widows. Its principal feature was formerly the dockyard, established by Henry VIII., enclosing an area of 31 acres, with three slips for ships of the line on the river front, two for smaller vessels opening into a basin 260 by 220 ft., and two dry docks, one communicating with the basin, and the other, a double dock, with the Thames. This famous yard, in which Peter the Great worked as a shipwright, and near which Queen Elizabeth visited Sir Francis Drake on board the Pelican, was closed in 1869. The victualling yard for the royal navy, which adjoins it, is still open, and contains sheep and cattle pens, slaughter houses, salting

establishments, an extensive mill, bakeries, an immense brewery, and cooper shops. There are several private dockyards in the town, and manufactories of some extent, including large engine and boiler works. The retail trade is considerable, and the market gardens are famous. The workhouse stands on the site of Sayes court, the mansion of John Evelyn, in which Peter the Great resided, and the once beautiful grounds are covered in part by the victualling yard.

**DE QUINCEY, Thomas**, an English author, known as the "English Opium Eater," born at Greenhay, a suburb of Manchester, Aug. 15, 1786; died in Edinburgh, Dec. 8, 1859. He was the fifth child of a merchant who at his death in 1793 left to his family a fortune of £1,600 a year. His childhood was chiefly passed in rural seclusion, with three sisters for playmates. He was sent to various schools, and early distinguished himself by proficiency in Greek. After vainly entreating his guardian to send him to the university, he ran away from school in 1802, and wandered about the country until he reached London, where he suffered terribly from exposure and hunger. Long afterward he wrote sketches of his life at this period; how much of these is true, how much fiction, it is impossible to say. According to his own account, he had in vain resorted to a Jew for an advance of money on the strength of his expectations, when at length an opening was made for reconciliation with his friends; and he attended school and visited in different parts of England and Ireland till he went to Oxford in December, 1803, where he remained till 1808. He first resorted to opium on a visit to London in the autumn of 1804, to dull the pains of rheumatism, and afterward took it habitually. He says that for ten years he "lived on the earth the life of a demiurgus, and kept the keys of paradise." It was his custom at this time to drink laudanum either on a Tuesday or Saturday night once in three weeks. On Tuesday night he went to the opera, where in the elaborate harmony and scenic display he saw unfolded the whole of his past life, with its passions exalted, spiritualized, and sublimed; not as if recalled by an act of memory, but as if present and incarnated in the music. On Saturday night he used to wander through the markets of London, and listen to the consultations of family parties on their ways and means, making himself familiar with their wishes, difficulties, and opinions. In 1809 he took the cottage at Gasmere which Wordsworth had occupied before him, and lived there constantly till 1819. Among his associates were Wordsworth and Coleridge at Gasmere, Southey at Keswick, Charles Lloyd at Brathay, and Wilson at Elleray. He afterward passed much of his time in London, Bath, and Edinburgh; his most intimate friend in London being for many years the celebrated peripatetic known as "Walking Stewart." He was occupied especially with the study of German literature

and philosophy, made translations from Lessing and Richter, and was among the first in England to interpret Kant, Fichte, and Schelling. In 1813 an irritation of the stomach, the consequence of his early sufferings, returned with a violence which yielded to no remedies but opium. From this time he became a regular and confirmed opium eater, taking sometimes as much as 320 grains a day. It had been the aim of his whole life to construct one single work, to which he proposed giving the title of an unfinished work of Spinoza, *De Emendatione Humani Intellectus*. The studies of many years had laid the foundation, but he could not command the efforts to rear the superstructure. In what he terms his state of imbecility he turned his attention for amusement to political economy. He welcomed the treatise of Ricardo as the first profound work on the subject, and it roused him to an activity which enabled him to draw up his "Prolegomena to all Future Systems of Political Economy." Yet opium paralyzed his efforts to complete even that short work. He failed to accomplish the preface; the arrangements for its publication were countermanded, and it first appeared in the "London Magazine," in 1824, under the title of "Templars' Dialogues." It is one of the most thorough as well as briefest exhibitions of the Ricardian theory of value. After two unsuccessful trials, he overcame his besetting habit, though it cost him a long and terrible struggle. In 1821 he went to London, and, as collaborator in the "London Magazine," became at once associated with Charles Lamb, Hazlitt, Allan Cunningham, Hood, Cary, and other writers. His "Confessions of an English Opium Eater" appeared in that periodical in 1821, and in a volume in 1822, and immediately obtained for him a high reputation. He contributed frequently to British periodicals, chiefly to "Blackwood's Magazine," "Tait's Edinburgh Magazine," and the "North British Review," furnishing autobiographical sketches, literary reminiscences, miscellaneous essays, and historical, philosophical, and critical discussions. He also furnished several articles to the "Encyclopædia Britannica," including the memoirs of Shakespeare and Pope. All his works show a wide range of learning and speculation, a delicate and subtle critical faculty, and a felicitous selection of words. He divides them into three classes: 1, papers whose chief purpose is to interest and amuse; 2, speculative, critical, and philosophical essays; 3, prose-poetry. His highest and most peculiar merit is in this third class, the best examples of which are his "Confessions" and "Suspiria de Profundis." In 1843 he removed to Lasswade, a village about 12 miles from Edinburgh. Here he returned to some of his earlier studies, and produced a volume entitled "The Logic of Political Economy." The first collective edition of his works was issued in Boston (21 vols., 1851-'9); it probably included a few things not written by him.

A selection from this American edition, with notes by the author, was commenced in Great Britain, of which nine volumes had appeared at the time of his death.

**DERA GHAZEE KHAN**, a large town of the Punjab, British India, 4 m. from the right bank of the Indus, and 40 m. W. by S. of Mooltan; pop. about 25,000, half Hindoos and half Mohammedans. It has 125 Hindoo temples and 160 mosques, and a bazaar with 1,600 shops; also manufactories of silk, cotton, and mixed fabrics, and coarse cutlery. Being at the intersection of two great routes of travel, it has considerable trade.

**DERAYEH**, or **Derbidjeh**, a town of Arabia, in Nedjed, lat.  $24^{\circ} 30' N.$ , lon.  $46^{\circ} 38' E.$ , 385 m. E. of Medina. It lies in a fertile and well watered valley at the foot of Mount Khur, and in the earlier part of this century was famous as the capital and stronghold of the Wahabees. It was then strongly fortified in the oriental style, and contained 40,000 inhabitants, 30 mosques, and 30 schools. In 1819 it was taken and destroyed by Ibrahim Pasha in the war for the suppression of the Wahabees. Although that sect is again dominant in Nedjed, Dera-yeh remains a mass of ruins and its environs are uncultivated, as it is considered unlucky to rebuild or reinstate a city so completely overthrown; and their seat of government is now Riad, about 10 m. S. E.

**DERBEND**, or **Derbent**, a fortified town of Russia in Daghestan, on the W. shore of the Caspian

sea, lat.  $42^{\circ} 3' N.$ , lon.  $48^{\circ} 15' E.$ ; pop. in 1867, 15,739, consisting of Mohammedans, Armenians, and Jews. The city rises from the harbor on the side of a wooded mountain, in the form of a quadrangle, and the summit is crowned by a citadel. The inhabitants manufacture silk, woollen, and cotton stuffs, and cultivate the vine and saffron. It is partly covered by walls, now dilapidated, but which were formerly of great strength, and also enclosed the defile known to the ancients as Albanian gates. From the iron gates of these walls it has its name, signifying "closed gates." Near Derbend commences the famous wall which extends westward for nearly 120 m. through Tabasseran, and formerly served as a defence to Persia against the northern barbarians. Its builder is unknown, some having attributed it to Alexander, others to Chosroes I. In 728 Derbend was taken from the Khazars by the Arabs, and in 1220 by the Mongols. In 1589 the Turks captured part of the town, but were again expelled. It was captured by Russia in 1722, restored to Persia in 1735, and taken again in 1795 by the Russians, who have kept it since.

**DERBY**, a town of New Haven co., Conn., on the Housatonic river, at its junction with the Naugatuck, 9 m. W. of New Haven; pop. in 1870, 8,020. The Housatonic and the New Haven and Derby railroads intersect here. The town has a fine landing on the E. side of the Housatonic, just below the junction of the Naugatuck, admitting vessels drawing 10 ft. of water, and was formerly extensively engaged in the West India trade and in ship building. It contains the villages of Ansonia and Birmingham. (See ANSONIA and BIRMINGHAM.)

**DERBY**, a parliamentary borough and the county town of Derbyshire, England, on the Derwent, and on the Midland railway, at its junction with several branch lines, 127 m. by rail N. N. W. of London; pop. in 1871, 49,793. It is the principal depot of the Midland railway company, with a station 1,050 ft. long. The town hall is a fine building with carvings in relief and a high clock tower. The church of All Saints is a splendid edifice, built in the reign of Henry VII. in rich Gothic style. St. Alkmund's church has a Gothic spire 205 ft. high. St. Peter's is the oldest and St. Andrew's the newest of the churches. There are 44 places of worship, of which 17 belong to the established church. There is a philosophical society founded by Dr. Erasmus Darwin, with a well stocked museum, a mechanics' institute, an atheneum, an infirmary, a county asylum, and a county prison. The free grammar school is one of the oldest in England. A fine arboretum of 16 acres, laid out in 1840 by Loudon, and presented to the city by Joseph Strutt, is a popular resort. There is also a new park of six acres, the gift of another citizen. Manufactures are carried on to a considerable extent, including silk, hosiery, lace, iron and brass work, carriages, harness, shot, and porcelain. The first

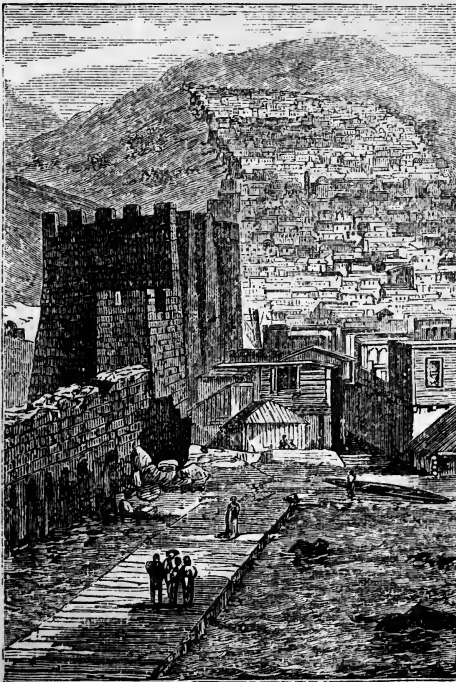

Derbend.

silk mill in England was built here in 1718, and there are now 25 establishments of the kind. The marbles and spars found in the vicinity are wrought into ornaments. Derby gives the title of earl to the Stanley family.

**DERBY. I. Edward Geoffrey Smith-Stanley**, 14th earl of, and Baron Stanley, a British statesman, born at Knowsley Park, Lancashire, March 29, 1799, died there, Oct. 23, 1869. He was educated at Eton and at Christchurch, Oxford, and was distinguished at the university for his classical attainments, gaining the prize for Latin verse in 1819. In 1821 he entered parliament as member for Stockbridge, and soon took rank among the ablest debaters and most prominent leaders of the whig opposition to the ministry of the earl of Liverpool. He was elected member for Preston, Lancashire, in 1826, and on March 11, 1827, took office as under secretary for the colonies in Canning's administration, which office he continued to hold in the Goderich cabinet until its dissolution in January, 1828. During the three years of the Wellington government he figured among the prominent orators and statesmen in the house of commons. On the formation of the reform cabinet of Lord Grey in 1830, he was appointed chief secretary for Ireland, with a seat in the cabinet. He failed of reelection from Preston, and represented the borough of Windsor from 1830 to 1832, when he was returned by one of the divisions of Lancashire. In the great struggle of 1832-'3, which resulted in the passage of the reform bill, the church temporalities bill, and the bill to establish national education in Ireland, Mr. Stanley took a brilliant and effective part, and was the strongest antagonist of O'Connell in his agitation for a repeal of the union. In 1833 he exchanged the office of chief secretary for Ireland for that of secretary of state for the colonies, being nominated to this post with the special object of carrying the abolition of slavery in the West Indies, which was effected under his auspices. In the following year, on the succession of his father to the earldom, he became known by the courtesy title of Lord Stanley, and in the same year retired from the cabinet in consequence of his non-concurrence with the ministerial proposition to appropriate the surplus funds of the Irish church establishment for secular education. In the brief administration of Sir Robert Peel (December, 1834, to April, 1835), Lord Stanley refused to take office, and long before the close of Lord Melbourne's administration he and his followers were found voting steadily with the conservative opposition, as avowed members of that party. In 1841 the whigs went out of office, and Sir Robert Peel formed a cabinet in which Lord Stanley occupied a seat as colonial secretary. In 1844, while his father was still living, he was summoned by writ to the house of lords as Baron Stanley of Bickerstaffe, and assumed the leadership of the conservative party in that body.

When Sir Robert Peel resolved in 1845 to adopt a free-trade policy, and remove prohibitive duties on foreign grain and breadstuffs, Lord Stanley left the cabinet and became the leader of the protectionist opposition. When, in December, 1845, Sir Robert tendered his resignation to the queen, Lord Stanley was invited by her majesty, at the instance of Lord John Russell, to form a protectionist cabinet, but he declined. During the six years of Lord John Russell's tenure of the premiership, Lord Stanley added to his already high fame as an orator and a statesman by his course as leader of the opposition in the house of lords. His speech on the Irish poor laws in 1849, that on the affairs of Greece in 1850, and his explanation of the reasons why he declined the premiership in February, 1851, when Lord John Russell's ministry were defeated in the house of commons on Mr. Locke King's motion for an extension of the franchise, are among the most remarkable of his forensic efforts. On the death of his father, June 30, 1851, he succeeded to the earldom and the vast ancestral estates of his family in England and Ireland. On Feb. 20, 1852, Lord John Russell having sustained another defeat on the militia bill, Lord Derby was again called to construct a cabinet, and succeeded in performing the task; but failing to obtain the support of parliament for his financial measures, he resigned in December of the same year. On the fall of the coalition ministry of Lord Aberdeen in 1855, he refused an invitation to form a new cabinet; but on the resignation of Lord Palmerston in 1858, he took the seals once more as first lord of the treasury. Being defeated on a measure of parliamentary reform, he dissolved parliament; but the new house of commons passed a vote of want of confidence in June, 1859, and he was consequently forced to resign. For seven years he remained out of office, and during that period devoted much time to the study of the classics. His translation of Homer's Iliad in blank verse, published in 1864, is one of the best versions of the great epic. He became prime minister a third time on the fall of the liberal ministry of Lord Russell in June, 1866, and under his administration the reform bill of 1867, establishing household suffrage, was passed. The new parliament, chosen on the issue of the disestablishment of the church in Ireland, was found to be strongly opposed to the government, and in February, 1868, Lord Derby resigned. A statue in his honor was erected at Preston in 1873.

**II. Edward Henry Smith-Stanley**, 15th earl, son of the preceding, born at Knowsley Park, July 21, 1826. He was educated at Rugby, and at Trinity college, Cambridge, where he took a first class in classics in 1848. Having been unsuccessful as a candidate for parliament from Lancashire in March, 1848, he set out on a tour of the United States, Canada, and the West Indies, and during his absence was returned from Lynn Regis, which he continued to represent

until he succeeded to the peerage. After his return in 1850 he made an able speech in the house of commons on the condition and administration of the sugar colonies. He next made a visit to the East, and while in India, in March, 1852, was appointed under secretary for foreign affairs in his father's first administration. In 1853 he submitted a plan for the reform of the administration of India, more thorough than that contemplated by the existing ministry, and foreshadowing that adopted in 1858. Though he was a conspicuous member of the conservative party, Lord Palmerston offered him a place in the cabinet in 1855, which he declined. He became secretary for the colonies in the second Derby cabinet in 1858, and on the resignation of Lord Ellenborough in May became president of the board of control, with the title of her majesty's commissioner for the affairs of India. The transfer of the management of Indian affairs from the East India company to the officers of the crown was effected under his direction, and he became the first secretary of state for India. In the third administration of Lord Derby, in 1866, he became secretary of state for foreign affairs, and conducted with marked success the negotiations for the settlement of the Luxemburg difficulty. He went out of office on the accession of Mr. Gladstone in December, 1868, and on April 1, 1869, was installed lord rector of the university of Glasgow. On the death of his father in October, 1869, he took his seat in the house of lords, of which he became one of the most influential members. In 1870 he married the dowager marchioness of Salisbury, and on Feb. 20, 1874, resumed the direction of foreign affairs as a member of Mr. Disraeli's cabinet.

**DERBYSHIRE**, a central county of England, bordering on Yorkshire, Nottinghamshire, Leicestershire, Staffordshire, and Cheshire; length 56 m., greatest breadth 34 m.; area, 1,030 sq. m.; pop. in 1871, 380,558. Capital, Derby. The county is level or moderately hilly, abounding in fine scenery, fertile, well cultivated, and rich in minerals. It is watered by the Derwent, Trent, Dove, Wye, Erewash, and Rother. The S. and E. parts produce wheat, barley, and other kinds of grain; the N. part, where the surface is more hilly and the climate colder, is occupied chiefly by oat fields and pastures. The elevated region called the High Peak or Derbyshire highlands, consisting of a succession of bleak hills, some of which rise nearly 2,000 ft. above the sea, interspersed with narrow valleys, is famous for its romantic scenery. The climate is rather cold and moist, thick fogs and even hoar frost not being uncommon in summer. Dairy husbandry is carried on in nearly all parts of the county, and among the hills small sheep and a breed of light, slender horses are reared. Among the minerals are coal, iron, lead, zinc, copper, gypsum, black and variegated marble, fluor spar, small crystals called Derbyshire diamonds, chalcedony, jasper, and a few onyxes. The

coal field covers a large area, and belongs to the same great field which extends over part of the West Riding of Yorkshire and part of Nottinghamshire. Mining is an important interest, and there are extensive founderies and forges in the large towns. The lead mines have been worked on lease from time immemorial, and are the subjects of several very ancient and peculiar laws. The county is traversed by a large number of canals and railways. The manufactures are important, and comprise cotton, silk, calico, cambric, fustian, muslin, tape, candle wicks, machinery, agricultural implements, leather, hats, paper, and porcelain. The first cotton mill was built by Richard Arkwright at Cromford in 1771, and the county was also the cradle of the silk and woollen manufactures of the kingdom. In the mountain district are numerous tepid mineral springs, which are resorted to by invalids, especially those of Buxton and Matlock. There are in the county numerous remains of the circles and cromlechs of the druids, various relics of the Roman domination, such as roads and baths, and ruins of many mediæval castles, abbeys, and monasteries.

**DERBYSHIRE SPAR**, a variety of fluor spar found in Derbyshire, England, which is distinguished by its fine shades of purple, blue, red, and yellow. These, together with the soundness of the stone, render it well adapted for ornamental purposes. The manufacture of cups, tables, vases, inkstands, and other objects, is extensively carried on in several towns of the county, as at Derby, Buxton, Castleton, and Bakewell. The stone takes a high polish for one so soft; but the property which renders it easy to be worked makes it liable to be soon defaced by scratches. It is found near Castleton in fissures in the limestone rocks.

**DERFLINGER**, *Georg von* (originally *Dörrfling*), a German soldier, born in Bohemia in March, 1606, died Feb. 4, 1695. At the age of 14 he fought in the Protestant army at the battle of Prague, and some ten years later entered the Swedish army as an officer under Gustavus Adolphus. His conduct in the Swedish victory at Leipsic, 1642, gained him the rank of major general. Afterward he entered the service of the elector of Brandenburg as lieutenant general, and distinguished himself against the Poles, Swedes, and French. In 1670 he became field marshal, and in 1674 baron of the German empire; routed the Swedes near Rathenau, June 15, 1675, and at Febrbellin three days afterward, and secured the greater portion of Pomerania for the elector. In 1678 he was made military governor of lower Pomerania; and in the winter campaign of 1678-'9 he caused 9,000 soldiers and 30 guns to cross the ice on sleds as far as Tilsit, and routed the Swedes near the latter city.

**DERG**, *Lough* (red lake), a lake in the county Donegal, Ireland, about 7 m. E. S. E. of Donegal, 3 m. long, and 2½ m. wide at the broadest part. It is enclosed on all sides except the

south by steep, barren hills from 700 to 1,200 ft. high. It lies 467 ft. above the level of the sea, and is 75 ft. deep. A multitude of islands dot its surface, one of which, called Station island, about an acre in extent, contains a cave known as St. Patrick's Purgatory, to which from 10,000 to 15,000 pilgrims from all parts of Ireland resort annually between June 1 and Aug. 15. They remain on the island, which contains two chapels, a house for the priests, and a few cabins, from three to nine days, their only food during that time being bread and water. Saint's isle, which was the original seat of St. Patrick's Purgatory, contains the remains of a priory founded in the 7th century.—There is another Lough Derg, forming an expansion of the river Shannon between Tipperary and Galway, about 24 m. long and from 2 to 6 m. wide.

**DERHAM, William**, an English divine and natural philosopher, born at Stoughton, near Worcester, in November, 1657, died at Upminster, near London, April 5, 1735. He became rector of Upminster in 1689, and canon of Windsor in 1716. He contributed largely to periodical literature, and edited some of the works of Ray the botanist and Hook the natural philosopher. As a member of the royal society he contributed valuable scientific papers to its "Transactions." The most important of his published works are: "The Artificial Clockmaker" (4th ed., 1734); "Physico-Theology" (16 discourses preached at Boyle's lecture, 1713), and "Astro-Theology" (1714), designed to prove the existence and attributes of God from an examination of the works of creation; and "Christo-Theology" (1730), a sermon to prove the divine origin of Christianity.

**DERMESTES**, the scientific name of the larder beetle (*D. lardarius*, Fabr.), one of the largest and most destructive of museum pests. It is about half an inch long, oblong-oval, with short legs, and black, the base of the wing covers with a grayish buff broad band. Slow in its movements, it seeks some crevice or feigns death when disturbed. The larvæ are hairy,

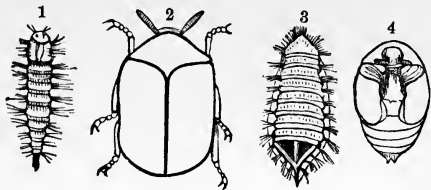

1. Larva of *Dermestes lardarius*. 2. *Anthrenus*. 3. Larva of *Anthrenus*. 4. Pupa of *Anthrenus*.

the body ending in a pencil of hairs. The genus *anthrenus*, of the same family of skin beetles, not more than one eighth of an inch long, generally less, is covered with transverse wavy bands of irregular spots; the larva is short and thick, with long bristles. Both these beetles commit their depredations in the larva

condition during the summer or latter part of spring; they attack and often completely destroy natural history specimens of every kind, where any animal matter remains. The constant evaporation of benzine, camphor, creosote, and turpentine in the museum cases will usually keep them out; specimens thoroughly impregnated with carbolic acid, arsenic, or corrosive sublimate are safe from their attacks. Their presence may be detected by the dust which they make falling beneath the specimens. The last is the *A. musæorum* (Fabr.).

**DERMODY, Thomas**, an Irish poet, born at Ennis in 1775, died at Sydenham, near London, in 1802. His father was a schoolmaster, and is said to have employed him while only in his ninth year as his assistant in teaching Latin and Greek. He afterward ran away to Dublin, enlisted in the army, and served in the expedition to Holland under the earl of Moira, who promoted him to a second lieutenantcy; but by his intemperate habits he lost the favor of his patron, and afterward lived some time in London, and died in extreme poverty. A small volume of poems written by him in his 13th year appeared in 1792. In 1793 he published a pamphlet on the French revolution, to which was appended a poem entitled "The Reform." During his residence in London he published two volumes of poems, in 1800 and 1802, and a separate poem, "The Battle of the Bards." His life, by J. G. Raymond, was published in 1805, and his works, under the title of "The Harp of Erin," in 1807, each in 2 vols.

**DERRICK.** See CRANE.

**DERRY.** See LONDONDERRY.

**DERVISH**, or *Dervise*, a Persian word equivalent to the Arabic *fakir*, signifying poor, used in Mohammedan countries to designate a religious class corresponding in some respects to the monks of Christendom. There are many orders of dervishes, distinguished by peculiarities of faith, ceremony, and costume. They are gathered usually into communities, each in charge of a sheikh, and live together in monasteries, but many dwell in villages with their families. Their discipline professes to be very strict, its chief requirements being poverty, chastity, and humility. Mendicity is forbidden, except in the order of the Bektashis, and their monastic rules require them to support themselves by the labor of their hands, though they are usually supplied by donations. With the exception of the order of the Mevlevis, all are allowed to marry and have dwellings outside of the convents, but must pass at least two nights of each week with their associates. Their religious rites consist of mortifications of the flesh, prayers, and dancing. Besides the fast of the Ramadan, they observe one weekly fast from morning till night, and they hold religious meetings on Tuesdays and Fridays. They are frequently to be seen in the streets haranguing the multitude and making a display of their wisdom and piety, but their

actual practices are often far from consistent with their professed standard. Some of them lead a vagrant life, and traverse all the countries of the East from the Mediterranean to the Ganges, being lodged and fed in the convents of their order; and they are occasionally met in European cities, playing the part of jugglers, sorcerers, and mountebanks. They wear coarse robes and go bare-legged and with the breast uncovered, and the use of intoxicating liquors and of opium is said to be common among them. The most numerous sect are the Mevlevis, or whirling dervishes, whose principal monastery is at Konieh in Anatolia. Their ceremonies consist chiefly of fantastic dances, in which they whirl around with great rapidity to the sound of a flute, stopping suddenly when the music ceases, or continuing until they drop from exhaustion. They do this in memory of their founder, Mevlevi Jelal



Turkish Dervishes.

ed-Din el-Rumi, the Persian poet, who died about 1262. He is said to have turned miraculously around for four days without food or nourishment, while his companion Hamza played the flute. The Rufais, or howling dervishes, sway their bodies backward and forward until they foam at the mouth and fall to the ground, vociferously ejaculating meanwhile the name of Allah and incoherent phrases. They are distinguished also for self-mortification. Their founder was Sheikh Ahmed Rufai, and they date from 1182. The Calenders are noticeable for their peculiar dress, which is sometimes parti-colored, and sometimes consists of only a sheepskin about the loins, while the upper part of the body is painted fantastically. There are older orders, but none of equal importance, and some that have various peculiarities of doctrine. The Munasihis believe in the transmigration of souls; the Esh-

rakis are given to a kind of poetical mysticism, seeing divinity in forms, colors, and sounds; and the Hairetis hold opinions almost equivalent to those of the ancient Epicureans.

—Religious orders similar to the dervishes are traced in the East beyond the Christian era, and tradition assigns many of the existing brotherhoods to the earliest days of Islam, the foundation of some being attributed to the caliphs Abubekr and Ali; but it is doubtful if any of them are older than the 9th century. The Marabouts among the Mohammedans of the Barbary states are similar to the dervishes.

**DERWENT**, the name of several rivers of England. **I.** A river of Cumberland, 32 m. long, rising in the district of Borrowdale, and flowing N. and then S. W. into the Irish sea, which it enters near Workington. It forms the cataract of Lodore near its head waters, and the lake of Derwentwater near Keswick, where it is joined by the Greta; expands into Bassenthwaite water at the town of that name, and receives the river Cocker at Cockermouth. Its banks abound in rich and varied scenery.

**II.** A river of Derbyshire, rising in a place called "the trough," in the mountains which extend along the N. boundary of the county, and uniting with the Trent on the borders of Leicestershire, after a course of about 50 m. Its general course is S. E. It passes Chatsworth house and the towns of Matlock, Belper, and Derby. Its scenery, particularly in the upper part, is beautifully diversified. **III.** A river of Yorkshire, East Riding, rising near Harwood dale, flowing nearly S. with many windings, and falling into the Ouse at Barmby, after a course of about 60 m. It is navigable to Malton, 27 m. above its mouth.

**DERWENT**, a river of Tasmania, rising near the centre of the island in Lake St. Claire, flowing S. E. into the district of Norfolk, and entering the S. Pacific ocean through an estuary which separates the districts of Hobart Town and Richmond. The estuary is about 4 m. broad at its entrance, and retains this width for a distance of 6 or 8 m. inland. On Iron Pot island at its mouth is a lighthouse with a fixed light 70 ft. above the sea.

**DERWENTWATER**, James Raddiffe, third earl of, a leader in the English rebellion of 1715, born in 1689, beheaded Feb. 24, 1716. He belonged to an ancient Catholic family in Northumberland, was educated at St. Germain, and succeeded to the earldom in 1705. He joined with other noblemen of the north and west of England, toward the end of 1714, in a plot for the restoration of the Stuarts. The matter coming to the knowledge of the government of George I., the *habeas corpus* act was suspended and warrants were issued against the suspected. The standard of rebellion having been raised in Scotland, Lord Derwentwater commenced the movement in England, Oct. 6, 1715. Mr. Forster, a Protestant member of parliament for Cumberland, was chosen leader, but recruits came in slowly, and the plans of the leaders

were ill formed and ineffective. After marching into Scotland, and returning without accomplishing anything, and skirmishing about in Cumberland and Lancashire, they encountered the British troops under Gen. Wills at Preston, and, after an action in which Derwentwater displayed great bravery, surrendered on a promise that their lives should be spared. Lord Derwentwater was impeached and brought to trial in January, 1716. He pleaded guilty, and threw himself on the mercy of the crown, alleging his youth and inexperience as an excuse; but he was condemned to death as a traitor, and notwithstanding great efforts to obtain his pardon was beheaded on Tower hill. He died protesting his loyalty to James III., and asserting that "dishonorable terms had been proposed to him as the price of his life, which he had refused to accept." His life was written by Sydney Gibson.

**DERZHAVIN, Gavriil Romanovitch**, a Russian lyrical poet, born in Kazan in July, 1743, died in July, 1816. He was admitted to the gymnasium of Kazan in 1758, and attracted the attention of the principal, who took him to St. Petersburg. He entered the cavalry, where he distinguished himself, and subsequently the civil service, and was successively governor of Olonetz and Tambov. In 1791 Catharine II. appointed him secretary of state, and a few years later president of the college of commerce. On Paul's accession to the throne he was placed at the head of the council of state. In 1800 he was imperial treasurer, and in 1802 minister of justice. His principal poems are the odes on the birth of the emperor Alexander, against irreligion, on the new year 1781, to God, and on God's majesty. Many of them abound with beautiful moral sentiments and expressions, especially his ode to God, which was not only translated into several European languages, but also into Chinese and Japanese. It is said to have been hung up in the palace of the emperor of China, printed in gold letters on white satin; and, according to Golovnin's account, it was placed in the same manner in the temple of Yedo. His complete works are in 5 vols. 8vo (St. Petersburg, 1810-'15).

**DESAGUADERO** (Span., drain). **I.** A navigable river of Bolivia, the outlet of Lake Titicaca, flowing 180 m. S. S. E. through the plain named from it, with a descent of about 490 ft., into Lake Aullagas, which has no outlet. Its width varies from 25 to 60 yards, and it is quite deep. The current is very slow. Near Lake Titicaca it is crossed by a bridge built by the fifth inca of Peru for the passage of his army. **II.** An immense inter-alpine plain comprised between the Cordilleras Oriental and Occidental of the Bolivian Andes, about one third in Peru, and the remainder in Bolivia, 400 m. long and from 30 to 80 m. wide. Save in the towns, the population is mainly made up of the Quichuas or Incas, and the Aymaras. From its elevation, which averages 13,340 ft. above

the level of the sea, its extent, and the number and height of the snow-capped peaks by which it is surrounded, it has been called the Thibet of South America. The main element in the formation of the more elevated portions is trachytic conglomerates in various stages of decomposition, especially in the northern parts, which are intersected by isolated hills and low mountain ranges. Corocoro to the north was long celebrated for its rich silver mines; and both silver and gold have been found in various localities, more particularly in the region contiguous to the Nevada de Illimani, from the base of which a large block of native gold was detached by lightning. The mass was afterward sold at an enormous price, and deposited in the museum of natural history at Madrid. The tin mines of Oruro are among the richest in the world; copper is said to be as plentiful in the mountain country as silver has been in the Cerro de Potosí; and many other minerals are likewise abundant; but, owing to the difficulty of transportation, these sources of wealth still lie unexplored. Of several thermal springs, those named Urimiri and Mochacamarcá are the best known. Notwithstanding the intertropical situation of the valley, its elevation gives it a mild and salubrious climate. The year is divided into two seasons: summer, from November to April; and winter, from May to October. During the former, which is the wet season, almost every day brings rain, and the nights are often chilly, with occasional frost; but during the winter snow and rain are never seen, except at the commencement and end. Not a tree is to be seen. The lower districts are clothed with a beautiful green turf, and in the valleys grows a coarse grass affording excellent pasture. Although the plain is well watered by the great Lake Titicaca, Lake Aullagas, the river Desaguadero connecting these lakes, another smaller lake, and many minor streams, the cereals do not attain maturity. Potatoes are plenty and grow wild; and the quinoa (*chenopodium quinoa*), often used as a substitute for the potato, is sedulously cultivated. The banks of Lake Titicaca have a luxuriant growth of rushes useful to the Indians for making huts, mats, boats, and other commodities. Remarkable among the fauna of the plain are the guanaco and the allied genera of alpacas, llamas, and vicuñas, all of which roam in numbers in every direction, yielding abundant fleeces of precious wool. Numerous herds of cattle graze along the banks of the rivers; horses, asses, and mules are very plentiful; and there are two rodents, a species of hare, and the bizcocha, whose burrowings render travel on horseback dangerous in many localities. Some delicious fish are taken in the lakes and rivers. Of the towns, which are few and small, Oruro is the most important.

**DESAIX DE VEYGOUX, Louis Charles Antoine**, a French general, born at St. Hilaire d'Ayat in Auvergne, Aug. 17, 1768, killed at Marengo,



June 14, 1800. He was educated at the military school of Effiat, where he remained seven years, leaving at the age of 15 to enter the regiment of Brittany under the name of the chevalier de Veygoux. He continued to be a diligent student in the garrisons of Briançon and Huningue. At the breaking out of the revolution he became the aide-de-camp of Prince Victor de Broglie in the army of the Rhine. He favored the principles of the revolutionists, but deprecated their violent acts, and having signed a protest against the decree of Aug. 10, 1792, by which the legislative assembly suspended the authority of the king, he was cashiered and imprisoned for two months, but was reinstated by Carnot. All through the reign of terror his head was in peril on account of his aristocratic connections. His mother and sister were sent to prison by the committee of public safety, but he escaped with a second brief suspension from the service. He was restored at the intercession of Pichegru, under whom he served with distinction, and of Saint-Just, and was employed in 1796 in defending the Alsatian frontier against the Austrians. When Moreau took command of the army of the Rhine, Desaix became his lieutenant as commander of a division, and took an important part in the campaign in Bavaria and the famous retreat with which it closed. On the return of the army to the Rhine, Desaix defended the fort of Kehl; and notwithstanding its dilapidated condition, he held it two months against the repeated efforts of the archduke Charles, and finally concluded a highly honorable capitulation. The next year he again led the army across the Rhine, an operation in which he showed consummate skill. After passing some months at Strasburg, recovering from a severe wound, he was sent at his own request on a mission to Bonaparte in Italy. On the formation of the army for the invasion of England he was made chief of staff to Bonaparte, who was to be its commander. In the expedition to Egypt he received the command of a division, and after the storming of Alexandria marched to Cairo with the vanguard. He took part in the battle of the pyramids, and being ordered to pursue Murad Bey, defeated him in several encounters, drove him into Nubia, and conquered the whole of Upper Egypt in eight months. Here he established a regular government, and inspired the Egyptians with such esteem that they called him "the just sultan." When Bonaparte embarked from Egypt, he sent Desaix a sword with the inscription, *Conquête de la haute Égypte*, and ordered him to return home in the following November. He arrived at Toulon May 3, 1800, and hastened to join Bonaparte in Italy, where he arrived June 11, and was put in command of a division, with orders to prevent the army which had just taken Genoa from joining that under Melas at Alessandria. He was at some distance from the main army on the morning of June 14, but on hearing the artillery hastily returned,

and arrived in time to change the nearly lost battle of Marengo to a complete victory. He was shot through the heart as he was entering the action. Bonaparte had a medal struck in his honor, and decreed that a statue should be erected to his memory in the *place des victoires* at Paris, and that his grave should be placed on the summit of the Alps, under the care of the monks of St. Bernard.

**DÉSAUGIERS, Marc Antoine Madeleine**, a French song writer and dramatist, born at Fréjus, Nov. 17, 1772, died in Paris, Aug. 9, 1827. At the age of 17 he produced a successful one-act comedy in verse. During the revolution he went to Santo Domingo, where his sister had married a planter; and when the insurrection of the blacks broke out, he barely escaped with his life to the United States, where he earned a living by teaching music. He returned to France in 1797, and wrote songs and light comedies. Some of his plays, such as *Les petites Danaïdes*, *La chatte merveilleuse*, and *M. Vautour*, had an unprecedented success; while his songs were more popular than those of any other writer except Béranger.

**DESAULT, Pierre Joseph**, a French surgeon, born at Magny-Vernais, a village of Franche-Comté, in 1744, died in Paris, June 1, 1795. He commenced his education for the church in a Jesuit school, but exhibiting a strong inclination for surgery, he was permitted to acquire the rudiments of the art from the barber-surgeon of his native village. He was then sent to the military hospital at Belfort, where he remained three years, giving special attention to gunshot and sword wounds. While here he translated Borelli's treatise *De Motu Animalium*, adding notes and illustrations. In 1764 he went to Paris, and availed himself of the facilities for dissection with such success that he soon opened a very popular school of anatomy. In 1776 he became a member of the college of surgery. Thereafter he made rapid progress, becoming successively chief surgeon to the hospital of the college, consulting surgeon to that of St. Sulpice, chief surgeon to La Charité, and finally to the Hôtel-Dieu, with the reputation of being the most skilful operator in France. In connection with the Hôtel-Dieu he instituted a clinical class which attracted many students. The most important cases that came before the class were reported in a serial, entitled *Journal de Chirurgie*, edited by the pupils. In the revolution he was arrested while lecturing, May 28, 1793, and carried to the Luxembourg, from which he was liberated at the end of three days. On the establishment of the school of health he was appointed clinical professor for external diseases. While attending the dauphin, then a prisoner in the Temple, he was seized with illness, which almost immediately terminated in delirium and death. The rumor of the time asserted that he was poisoned because he refused to lend himself to the murder of his patient. An autopsy showing no trace of poison, his death was set

down to ataxic fever. The republic pensioned his widow. He introduced numerous improvements in surgical instruments and their use, especially for the treatment of fractures and ligation of arteries. In conjunction with his friend Chopart, he wrote the *Traité des maladies chirurgicales* (2 vols. 8vo, 1780), which has been translated into English by Trumbull. His *Œuvres chirurgicales* were published by Bichat (3 vols. 8vo, 1798-'9).

**DES BARRES, Joseph Frederick Wallet**, an English soldier and hydrographer, born in 1722, died in Halifax, N. S., Oct. 24, 1824. He was descended from a French family which emigrated to England after the revocation of the edict of Nantes. Graduating from the royal military college at Woolwich, he embarked in March, 1756, as lieutenant in the 60th regiment of foot, for America. Having raised more than 300 recruits in Pennsylvania and Maryland, he formed them into a corps of field artillery, which he commanded until the arrival of one of the battalions of the royal train from England. In 1757 he commanded a detachment of volunteers against the Indians, who had committed depredations in the neighborhood of Schenectady and other frontier towns, and not only defeated them, but won them over to the assistance of the English. In 1758 he was engaged in the expedition against Louisburg, where he did good service; and after the capitulation he drew up a chart of the St. Lawrence, which was useful in the campaign of the next year. At the siege of Quebec he was aide-de-camp to Gen. Wolfe, and was making his report when that hero received his mortal wound, and fell dying in his arms. In 1760 and subsequently he conducted the operations for the defence of Quebec and the other places acquired by the British, as well as those for the reduction of Fort Jacques Cartier and others that still held out, thus completing the conquest of Canada. He was afterward ordered to Nova Scotia to assist Gen. Bastide in tracing designs and making estimates of the expense for fortifying the harbor of Halifax, and securing its dockyard. In 1762 he served as directing engineer and quartermaster general in the expedition for retaking Newfoundland, and received public thanks for his service in the recovery of that island. After making surveys of some of its principal harbors, he was ordered to New York, to proceed on reconnoitring excursions and report observations on the expediency of establishing a chain of military posts throughout the British colonies. In 1763 Lord Colville received instructions to employ him on the survey of the coast of Nova Scotia, in which he was engaged till 1773. The want of correct charts of the coast of North America for the fleet engaged in carrying on the American revolutionary war being severely felt, he was selected to adapt the surveys of Holland, De Brahm, and others to nautical purposes. These he published in 1777 under the title of "The Atlantic Neptune," in two

large folio volumes. In 1784 he was appointed governor of the island of Cape Breton, and military commander of that and of Prince Edward island; and soon afterward he commenced building the town of Sydney, and opened and worked the valuable coal fields at the entrance of the river. In 1804 he was appointed lieutenant governor and commander-in-chief of Prince Edward island, being then in his 82d year. In person he was short, and at the age of 95 lithe and active. He was Capt. Cook's teacher in navigation.

**DESCARTES, René** (Lat. RENATUS CARTESIUS), a French philosopher, born at La Haye, Touraine, March 31, 1596, died in Stockholm, Feb. 11, 1650. He was the youngest son of a councillor of the parliament of Rennes, of an ancient and noble family, and early in life evinced such a disposition to inquire into the nature and causes of things, that he was called the young philosopher. His education was conducted in the Jesuit college of La Flèche, where he made rapid progress in the Greek and Latin classics, and the other ordinary studies of such an institution. He contracted also while there a friendship with Mersenne, which lasted until the end of his life; and though Mersenne became a monk, it was chiefly through him that Descartes communicated, from his profound scholastic retirement, with the outside learned world. After leaving college, in his 16th year, he occupied himself in preparing for the military life to which he was destined by the wishes of his family and the spirit of the times. But his health being delicate, he was sent to Paris with a tutor, to pass two years in the further prosecution of his studies. In 1616 he joined the army of Maurice of Nassau, and while in garrison at Breda composed his *Compendium Musica*, which seemed a prelude to the research for harmony which he was soon about to carry into all the realms of knowledge. He was driven to it, doubtless, by the painful uncertainty and chaotic confusion which reigned in nearly all the departments of human inquiry. He was troubled by the doubts of his epoch, but he shared also in its grand hopes. In 1619 he left the Dutch army, and entered as a volunteer the service of Maximilian of Bavaria, the head of the Catholic league; he was present at the battle of Prague in 1620, and made with the imperialists the campaign of Hungary in 1621. The atrocities which he witnessed in this war are said to have been the occasion of his resigning his commission. After visiting the greater part of the north of Europe, he returned to France, sold his estates, and speedily resumed his journeys. He spent some time in Switzerland and Italy, being present at Rome during the jubilee of 1625; and wherever he went observing the phenomena of nature, and perfecting himself in the acquisition of knowledge. At Neuburg, on the Danube, where he passed the winter, the plan of devoting the remainder of his days to the reconstruction of the principles of hu-

man knowledge, which had long been maturing in his mind, took a definite shape. While he wandered from the Baltic to the Mediterranean, he was digesting the outlines of the great discoveries in geometry and method, destined soon to change the intellectual currents of the world. Going first to Paris, where he moved about from one obscure house to another to escape the intrusion of friends, he next settled in the neighboring country, and finally fixed his retreat in Holland. Emancipated from all social ties and relations, his life became that of an ascetic. In 1633 he made a brief visit to England, and the following year to Amsterdam; and he constantly, through the mediation of Mersenne, maintained an active correspondence with the learned men who sought his instruction or his friendship. In 1637 he began a more open career by the publication of a volume entitled *Discours de la méthode*, which contained treatises on method, on dioptrics, on meteors, and on geometry. The first of these, besides an admirable picture of his life and of the progress of his studies, furnished a clear outline of a new science of metaphysics, only expanded in his later and larger works. In 1641 he published in Latin *Meditationes de Prima Philosophia*, which carried his speculations into abstruse questions as to the existence of God and the immortality of the soul. He invited criticisms of these, which in later editions are arranged and replied to under seven heads, wherein he considers all the objections raised to his original system. These works filled Europe with his name, and at the close of 1641 he was invited to France by Louis XIII., but he refused to quit his retirement. In 1644 appeared *Principia Philosophiæ*, which three years later was translated into French by Claude Picot. He then went to France, where a pension of 3,000 livres a year was conferred upon him; but as Queen Christina of Sweden invited him to Stockholm, at the same time appointing him director of an academy which she proposed to establish, at a salary of 3,000 crowns a year, he was induced once more to abandon his native country. The rigors of the climate, combined with the early hours exacted by the queen, in an eccentric wish to take lessons from him, led to his death in less than two years. He was buried at Stockholm; but 16 years afterward Louis XIV. caused his remains to be disinterred and carried to France, where he was entombed in the church of Ste. Geneviève du Mont.—Descartes created an epoch in the history of the human mind, and should be classed with men like Plato, Aristotle, Bacon, Newton, and Kant. With Bacon, he was one of the founders of modern philosophy, but he pushed his inquiries further than Bacon in many respects, and in a somewhat different sphere. What the latter accomplished for natural science, Descartes accomplished for moral and metaphysical. As a metaphysician, he was the fountain head of the speculation of a whole subsequent century, while he added to

his glory in that sphere the scarcely inferior distinction of a great discoverer in mathematics, and of an earnest laborer in nearly all the domains of physical science then known. Not wholly exempt from the errors of his day, he was yet immeasurably in advance of his day; while he enjoys this singular eminence among philosophers, that his expression is as clear and beautiful as his thought is great. French style appears nowhere more simple and direct than in the varied dissertations of Descartes, even when he treats of subjects the most recondite and difficult. It was owing to this admirable clearness, perhaps, as much as to the more essential merits of his system, that it was said at the time of Descartes's death that everybody in England and France, who thought at all, thought Cartesianism. The fundamental principles of the philosophy of Descartes relate to his method, which takes its point of departure in universal doubt, and places the criterion of all certitude in evidence, or in other words, in reason, as the sovereign judge of the true and the false; to the erection of the individual consciousness into the fundamental and source of all correct philosophy (*Cogito, ergo sum*); to the radical distinction which is drawn between the soul and the body, the essential attribute of the former being thought, and that of the latter extension; to the demonstration of the existence of God from the very idea of the infinite; to the division of ideas into those which are innate, those which are factitious, or created by us, and those which are adventitious, or come from without by means of the senses; to the definition of substance, as that which so exists as to need nothing else for its existence, and which is applicable in the highest sense only to God, who has his ground in himself, but only relatively to the thinking and corporeal substances, which need the coöperation of God to their existence; and to the affirmation that the universe depends upon the productive power, not only for its first existence, but for its continued being and operation, or in other words, that conservation is perpetual creation. Other points in this philosophy are important, and other aspects of it are to be regarded by the student; but for the popular reader these chiefly deserve attention, because these were characteristic and creative, and furnished the themes for the greater part of the agitated discussions of later years. From his theory of doubt, except upon evidence, for instance, the philosophy of the 17th century, and the whole of modern philosophy in fact, derived that disdain for the authority which formerly fettered the free movements of the mind, and that reliance upon reason, which Arnauld, Malebranche, Pascal, Bossuet, Fénelon, and others appealed to so effectively. The vivid determination of the consciousness, or the Me, as the proper object of metaphysical investigation, was the starting point of those great systems of thought, both Scotch and German, which are such remarkable phenomena in the history

of intellectual development. It is also easy to trace to his doctrine of substance the pantheistic speculations of Spinoza, Fichte, and Hegel. In short, the schemes of Geulinx, Leibnitz, Wolf, Kant, and perhaps of Swedenborg, are all more or less directly affiliated to the great leading ideas of the French thinker. As a whole, therefore, it is not surprising that his system produced an instant and vivid sensation. The scholastics were astonished by an assault at once so radical and so vital; the skeptics saw a skepticism more searching than theirs rising into the most solid religious faith; while the independent men of science, who had long been struggling against the methods of the old dialectics, received with joy a doctrine which seemed to place their researches on an immovable foundation, and to promise to crown them with the richest fruits of progress. For a while Descartes threatened to succeed to the place of absolute dictation and mastery which had been so long assigned to Aristotle. His influence passed from the cloister and the study to popular literature; all the great writers of the age of Louis XIV. were tinctured by it; but just as it appeared to have attained a universal acceptance, it began as rapidly to fade and shrink. The reasons of this decline are to be found partly in the growth of Locke's sensational philosophy; partly in the demonstrated impotence of Descartes's principles to resolve many of the higher problems to which he aspired; but chiefly in the discoveries of Newton and the progress of physics, which discredited his physical theories, and therefore brought his metaphysical conclusions into distrust. The theory of vortices, by which he endeavored to explain the movements of the heavenly bodies, gave place to the simpler theory of Newton as to a law of universal gravitation; but science has not ceased to confess its obligations to Descartes for his important discoveries as to the application of algebra to geometry, his contributions to dioptrics, to mechanics, and to hydrostatics, and for that fearless spirit of investigation which, if it led him into mistakes, enabled him also to anticipate many truths ascribed to a later period.—After the death of Descartes, in addition to the works already mentioned, were published *Le monde de Descartes, ou le traité de la lumière* (12mo, Paris, 1664); *Le traité de l'homme et de la formation du fœtus* (4to, Paris, 1664); and *Les lettres de René Descartes* (3 vols. 4to, 1657-'67). The principal complete editions of his writings are: *Opera Omnia* (8 vols., Amsterdam, 1670-'83); *Œuvres complètes de Descartes* (9 vols., Paris, 1724); *Œuvres complètes de Descartes*, by Victor Cousin (11 vols., 1824-'6), which is perhaps the most perfect edition; and *Œuvres philosophiques de Descartes* (1835), by Garnier, who added a life and a thorough analysis of all his writings. The dissertations on his philosophy are almost without number, but the few most useful or curious are comprised

in the following list: *Recueil de pièces curieuses concernant la philosophie de Descartes*, published by Bayle (Amsterdam, 1684); *Mémoires pour servir à l'histoire du Cartésianisme*, by Huet (Paris, 1693); *Mémoires sur la persécution du Cartésianisme*, by Cousin (Paris, 1838); *Histoire et critique de la révolution cartésienne*, by M. Francisque Bouillier (2 vols., Paris, 1842); and *Le Cartésianisme, ou la véritable rénovation des sciences*, by Bordau-Demoulin (2 vols., Paris, 1843). Of late years the study of Descartes has revived among the French philosophers. See Damiron's *Essai sur l'histoire de la philosophie en France au XIX<sup>e</sup> siècle* (1828) and *Essai sur l'histoire de la philosophie au XVI<sup>e</sup> siècle* (1846); Bouillier's *Histoire de la philosophie cartésienne* (2 vols., 1854; 2d ed., 1867); and Millet's *Descartes, sa vie, &c.* (1867).

**DESCENT**, in law, the transmission of an estate in lands by operation of law, upon the decease of a proprietor, without any disposition thereof having been made by him. The term is derived from a principle existing until very recently in the English law, that an inheritance could never lineally ascend, yet upon failure of lineal descendants it could ascend collaterally. Thus the father could not be the heir of his son, but the uncle could inherit from the nephew. There was therefore an inaptness in the expression even as used in the common law doctrine of inheritance, and still greater incongruity in American law, which allows a lineal ascent from the son to the father. Succession is the more appropriate phrase in the Roman law, and from that adopted in the French and other modern systems. Gibbon has well remarked that the Roman law of hereditary succession "deviated less from the equality of nature than the Jewish, Athenian, or English institutions." The oldest son of a Hebrew inherited a double portion. By the Athenian law the sons inherited jointly, but the daughters were wholly dependent upon what provision their brothers might choose to give them by way of marriage portion. The English law of primogeniture gives, not a larger portion, but the whole, to the eldest son; and in various other respects which will be presently referred to, the natural order of equity is singularly disregarded in the law of descent. On the other hand, by the Roman law, when a man died intestate, all his children, both sons and daughters, inherited alike; and in case of the decease of either, the descendants of the decedent would take such share as would have belonged to him or her. The distinction of agnates and cognates was indeed introduced at an early period, whereby the descendants of females, who were called cognates, were excluded; but by imperial constitutions they were restored to the right of succession, with a diminution of a third in favor of the agnates, that is, descendants of males, and even this discrimination was abrogated by Justinian. On failure of lineal de-

scendants, the father and mother or other lineal ascendants were admitted. Such was the rule as to lineal succession. In respect to collateral inheritance, by the law of the twelve tables, agnates, whether male or female, were admitted alike, but by the latter law all females of collateral kindred were excluded; the hardship of the rule was in some measure relieved by the prætor, who gave to females thus excluded a share of the personal estate. Justinian restored the right of succession as it had originally existed. Descendants of females of the collateral kindred were still, however, left unprovided for. Thus, though a sister could inherit from her brother, yet her children could not; but the reverse of the rule did not hold, for there was no corresponding disability in the brother to inherit from the children of his sister. The rule of collateral succession was that the nearest agnate (or all the agnates of the same degree) took the whole estate. The mode of estimating the degree of consanguinity by the Roman law was to take the entire number of intermediate persons in the ascending and descending scale between the parties whose relationship was in question; thus, first cousins would be related in the fourth degree, being each two removes from the common ancestor. But by the canon law, which has been taken as the basis of the English rule of descent, the consanguinity is measured by the number of degrees between the more remote of the two persons and the common ancestor, which in the case of cousins would be two degrees; and it would be the same between uncle and nephew. The rules of descent by the common law of England are exceedingly artificial, being derived chiefly from the old feudal system, and by usage become fixed, though the reasons that first gave rise to them have long ceased to exist. The principal of these rules are as follows: 1. The estate descends lineally to the oldest son, to the exclusion of all others; or if he is deceased, then to his descendants, male or female, following the same rule of preference in all respects as prescribed in this and the following rules. 2. In case of the decease of the oldest son without issue, then to the next oldest and his descendants, and so to the last of the males. 3. In case of failure of male issue, then to the daughters, who, contrary to the order prescribed in the preceding rules, do not take successively, but become seized jointly of a peculiar estate called coparceny, each coparcener having an absolute undivided interest, which she may convey, or which on her decease will descend to her heirs. 4. Failing all lineal descendants, the estate does not ascend lineally (that is to say, to the father or grandfather, who by the common law are incapacitated to take directly from the son or grandson, though they may indirectly through collateral heirs), but to the nearest collateral kindred, still following the preference of males to females, and, of the males of the same degree, the oldest having the ex-

clusive right. Thus the oldest brother and his descendants will take; failing whom, the next brother and his descendants; or in default of brothers, then all the sisters in coparceny; but if there be no brothers or sisters, then the kindred of next degree will succeed, subject to the same rules of preference. 5. In respect to collateral succession, several other rules apply. (a.) The heir must be not only the nearest of kin of the person last seized, but must be of the whole blood, that is to say, must be descended from the same two ancestors, male and female; as, if A and B are brothers having the same father but not the same mother, if an estate descends to A from the father and he dies, B shall not inherit from him, although if A had died before the father B would have been the heir of the father. So far was this exclusion carried by the common law, that a sister of the whole blood would take in preference to a brother of the half blood, and the estate would even escheat rather than it should descend to the latter; and the same rule prevailed in respect to more remote collateral relatives. (b.) It is also necessary, in order to inherit collaterally, to be of the blood of the first purchaser, that is to say, of the person who first acquired the estate; as, if A purchase land and it descends through several generations to B, who dies without issue, no collateral relative of B can take the estate unless he is also of the blood of A, from whom it originally came. (c.) Kindred on the side of male ancestors, however remote, are preferred to kindred descended from females, however near, unless the estate descended from a female, in which case the kindred of such female can alone inherit. Thus the relatives on the father's side are preferred to the mother's, and on the grandfather's to the grandmother's, and so in all the degrees of ancestry. (d.) In computing degrees of consanguinity, the rule of the canon law is adopted as before mentioned, whereby the relationship to the common ancestor is alone considered. According to this rule, brothers are related in the first degree, cousins in the second; but as this would often make a different degree of relationship between the same parties, according as it was computed from one or the other to the common ancestor, it was found necessary to adopt a further rule, that the consanguinity of each to the other was to be determined by that of the most remote from the common ancestor. Again, there might sometimes be different sets of kindred in the same degree of relationship by referring to different ancestors, as a nephew is in the same degree as an uncle, the common ancestor of the one being the father, of the other the grandfather; in such a case, another rule intervenes, viz.: that the relative representing the nearest ancestor shall take priority, according to which the nephew would inherit before the uncle. Several important changes have been made in the law of descent by statute 3 and 4 William IV., c. 106 (1833), the principal of which are: 1. That a lineal ancestor is permitted to inherit,

and takes precedence of a collateral heir; thus the father is preferred to the brother or sister.

2. Relatives of the half blood are relieved from disability to inherit, and succeed next after relatives of the same degree of the whole blood.

3. Several provisions are made for the determination of the question who was the purchaser from whom by the rules of common law the descent was to be traced. The person last entitled is to be deemed a purchaser, unless it be shown that he took by inheritance, and so of any preceding ancestor. In the case of a devise by a man to his heir, such heir shall be deemed to have taken by the devise and not by descent, and is to be regarded as a purchaser. When land is purchased under a limitation to the heirs of a particular ancestor, such ancestor is deemed the purchaser. From this summary of the English law of descent, which gives only the general rules without noticing certain exceptions which are said to exist by ancient usage in some places, it is apparent that the basis of the system was a condition of society no longer existing. The theory of seeking for a single male heir to the exclusion of all others belongs to the turbulent period when a military head of a family was needed, and all the other members of the family found shelter in a common mansion, under the protection of an organized domestic force. The perpetuation of the rule, in a period of private immunity from violence, can serve no other purpose than to keep together the estates of great land proprietors. This may be essential for maintaining the respectability of the titles of nobility, but is inapplicable to all other proprietors; and moreover, personal property, which was comparatively unnoticed by the feudal law, but which has become a large portion of the wealth of the kingdom, is distributed by another rule, conforming to the equitable principle of the civil law. The retention of this part of the old feudal law is therefore mainly attributable to the prejudice in favor of ancient usage which has always been characteristic of the English.—The law of descent in the United States is based upon the English statute (22 and 23 Charles II.) for the distribution of the personal estates of intestates, which statute is substantially in conformity with the civil law. In most of the states real and personal estate descend by the same rule, with the exception only of the interest of the husband and wife respectively, the former of whom may have an estate by curtesy, and the latter in dower. (See CURTESY, and DOWER.) The rule of descent in the state of New York, which may be taken as the law of most of the other states, is: 1. Of the lineal descendants of the intestate, an equal portion to all who are of equal degree of consanguinity, whether male or female; but in the case of the decease of any one of them, then his or her descendants take the portion that would have belonged to such deceased party if living; thus, should the intestate leave two children and three grand-

children, descendants of a deceased child, the estate will be divided into three parts, the three grandchildren taking the one third which would have belonged to the parent whom they represent. 2. Upon the failure of lineal descendants, the father of the intestate will inherit, unless the estate came by descent on the part of the mother. 3. If the father is not living, or cannot for the reason above mentioned take the estate, the mother will be entitled to hold it for life, the reversion to belong to the brothers and sisters. 4. If no lineal descendants or father or mother, then the estate will descend to the nearest collateral relatives of equal degree; and the same rule applies as in the case of lineal descendants, that the descendants of a deceased party take the same share that such ancestor would have been entitled to if living. The rules as to collateral succession are as follows: (a.) Brothers and sisters, or the children of deceased brothers and sisters, are first entitled; but in case no brother or sister is living, but there are descendants of several, then such descendants take equally *per capita*, and not *per stirpes* or representation, as would be the case if one of the brothers or sisters were living. (b.) If no brothers or sisters of the intestate nor descendants of deceased brothers or sisters, the next heirs are uncles and aunts, who take equally unless the estate came by descent on the part of one parent, in which case the relatives of that parent have the preference. Lineal and collateral relatives of the half blood take equally with those of the whole blood. In some of the states the brothers and sisters take to the exclusion of the parents, while in others the rules are still more liberal toward the parents than as above stated.—The rules of succession by the French civil code are nearly the same as those prevailing in this country. The variations are principally these: 1. If there are father and mother (or either of them) and brothers and sisters, the estate is divided into two parts, one of which belongs to the father and mother in equal proportion, the other to the brothers and sisters or descendants of a deceased brother and sister, such descendants taking by representation the share that the child whom they represent would have taken; if either father or mother is deceased, his or her share vests in the brothers and sisters. 2. If there is a father or mother, but no brothers or sisters, the collateral relatives take a half. 3. If there are children of different father or mother, the estate is divided into two parts, the paternal line taking one part and the maternal the other; children of the whole blood take a share in each moiety.

**DESERTER**, in military affairs, an officer, soldier, or sailor who abandons the public service in the army or navy, without leave. In England the punishment for desertion is, with certain limitations, left to the discretion of courts martial, death being the extreme penalty. By the articles for the government of the navy of the United States (art. 12), it is enacted that

"if any person in the navy shall desert to an enemy or rebel, he shall suffer death," and (art. 13) "if any person in the navy shall desert in time of war, he shall suffer death, or such other punishment as a court martial shall adjudge." The rules and articles for the government of the land forces of the United States authorize the infliction of corporal punishment not exceeding 50 lashes for desertion in time of peace, by sentence of a general court martial; and the laws do not permit punishment by stripes and lashes for any other crime in the land service. In time of war a court martial may sentence a deserter to suffer death, or otherwise punish at its discretion.

**DESFONTAINES, René Louiche**, a French botanist, born at Tremblay, Brittany, about 1752, died in Paris, Nov. 16, 1833. After studying at the college of Rennes, he went to Paris to prepare for the medical profession, but devoted himself chiefly to botany. In 1782 he received his degree as doctor, and in the next year wrote a paper on the organs of fructification in plants, which procured his admission into the academy of sciences. He then, at the expense of the academy, set out for the Barbary states, and during two years explored the natural history, especially the flora, of the north of Africa. He published the result in the *Flora Atlantica* (2 vols., Paris, 1798), which described 1,600 species of plants, 300 of which were new. After his return to Paris in 1785 he was appointed by Buffon to succeed Lemonnier as professor in the *jardin des plantes*, and from this time was employed in the duties of that office. His lectures treated of the physiology and anatomical structure of plants, rather than of their nomenclature. He was the first to indicate the difference in growth and structure between the monocotyledonous and the dicotyledonous plants. He made a botanical catalogue of the *jardin des plantes* (1804; 3d ed. in Latin, 1829), continued the *Collection des velins du muséum d'histoire naturelle*, which had been begun for Gaston of Orleans, published works on arboriculture and the artificial fecundation of plants, and wrote numerous memoirs.

**DESFUL**, or **Dizful**, a city of Persia, in the province of Khuzistan, on the E. bank of a river of the same name, 25 m. W. N. W. of Shuster; pop. estimated at 15,000. It is the principal mart of the province, and has a fine bridge of 22 arches, said to have been built by command of the celebrated Sapor. Indigo, oranges, and lemons are raised in the neighborhood. About 10 m. S. W. of the city are mounds of ruins, the foundations of which are of stone, and the upper portions of brick, which cover the site of the ancient city of Susa, and beds of large canals, supposed to be of Sassanian origin.

**DESHA**, a S. E. county of Arkansas, separated from Mississippi by the Mississippi river, and intersected by Arkansas and White rivers; area, about 600 sq. m.; pop. in 1870, 6,125, of whom 3,934 were colored. The area has recently been

diminished by the taking of a portion for Lincoln county. The surface is low, level, and subject to inundation. The chief productions in 1870 were 94,797 bushels of Indian corn, 11,387 of sweet potatoes, 7,041 of Irish potatoes, and 8,166 bales of cotton. There were 804 horses, 1,018 mules and asses, 1,397 milch cows, 2,811 other cattle, and 7,042 swine. Capital, Napoleon.

**DESHOULIÈRES, Antoinette (DU LIGIER DE LA GARDE)**, a French authoress, born in Paris about 1634, died there, Feb. 17, 1694. She was the daughter of a *maître d'hôtel* of Maria de' Medici and Anne of Austria, and was early noted for beauty and wit. She began to write verses when very young. In 1651 she was married to Guillaume de la Fon de Boisguérin, seigneur des Houlières, who in the troubles of the Fronde embraced the party of the prince of Condé, and was exiled. She subsequently joined her husband at the court of Brussels, where she became an object of suspicion, and was imprisoned in 1657 in the castle of Vilvoorden, where she read the Scriptures and fathers of the church. She was rescued by her husband after eight months, and on her return to France after the amnesty became a favorite at the court of Anne of Austria. She wrote poems in almost all styles, from madrigal to tragedy; but her idyls, especially those entitled *Les moutons* and *Les fleurs*, were most admired, and gained her the appellation of the tenth muse and the French Calliope. The subsequent ill success of her tragedies caused this advice to be given her, *Retournez à vos moutons*. She became a member of the academy of the Ricovrati of Padua in 1684, and of the academy of Arles in 1689. Like Mme. de Sévigné, she belonged to the literary clique hostile to Racine. Voltaire said that of all French ladies who had cultivated poetry, Mme. Deshoulières had succeeded best, since more of her verses than those of any other were known by heart. The principal editions of her works are those of 1747 and 1799, each in 2 vols.

**DESMAN**, an insectivorous mammal of the shrew family, *mygale (galemys) Muscovitica* (Desm.). It is 7 in. long, with a tail of 8 in.; it is brown above and white below, the fur being very soft and long; the feet are webbed, and the flattened tail is covered with scales, and is a powerful rudder; the nose is lengthened into a flexible proboscis. It is found in the Volga and adjacent streams and lakes in S. E. Russia, making burrows in the banks, beginning under water, and ascending above the level of the highest floods. The food consists of small fishes, frogs, leeches, and larvæ of aquatic insects. It is itself devoured by pikes and other voracious fishes, to whose flesh it communicates a strong musky odor, from the penetrating secretions of glands near the tail. It is rarely seen on dry land; it is an excellent diver and swimmer, and, from its aquatic habits and the rodent look of the in-

cisor teeth, was formerly classed near the beaver; the teeth, however, are like those of the shrews, differing in having two very small ones between the two great incisors of the

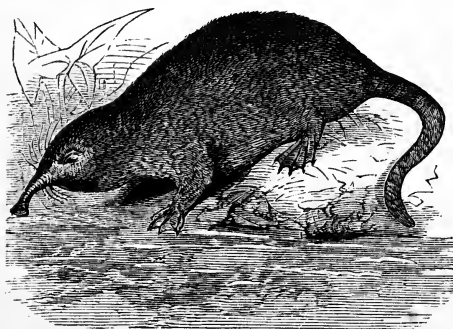

Desman (*Mygale Pyrenaica*).

lower jaw, and in the two upper triangular and flattened incisors. The *M. (G.) Pyrenaica* is not much more than half the size of the Russian species; it is found in southern France, in the district of the Pyrenees.

**DESMARRES, Louis Auguste**, a French oculist, born in Evreux in 1810. He studied at the Sorbonne, and devoted himself entirely to the treatment of diseases of the eye, and soon acquired a great reputation. He has contributed largely to a better understanding of the pathology and anatomy of the eye, and invented an ophthalmoscope which is now in general use among practitioners. His *Mémoire sur une nouvelle méthode d'employer le nitrate d'argent dans quelques ophthalmies* (1842) and *Emploi de la belladonne dans les perforations de la cornée*, excited special attention; but his most important work is his *Traité théorique et pratique des maladies des yeux* (1847), which he considerably enlarged in subsequent editions, and which is considered a standard authority on the subject.

**DESMIDIEÆ**, minute algæ, or protophytes, which grow in fresh water, and whose forms present singularly beautiful appearances under the microscope. For a long time claimed both as animals and plants, they seem to stand on the limits of either kingdom. The controversy as to their true place has enlisted a great number of observers, who have submitted every fact to the most rigorous examination. Ehrenberg claimed them as animalcules; Dalrymple gave extended observations upon a single genus (*closterium*), which appeared to him to indicate animality; and Prof. Bailey and C. Eckhard arrive at the same conclusion. The latter derives his argument for their being animals partly from their motion, partly from their organization. Ehrenberg has not only given systematic descriptions of these questionable animals or plants, but his own observations, coupled with those of his predecessors, upon the nature of these bodies, will be found copiously detailed by him. It is, however, apparent

that all the facts known upon the subject are interpreted as if these creations were undoubtedly animals, while the same facts would bear a very different signification if we proceeded upon the supposition that they are plants. Meyen contended for the vegetable character of the desmidieæ, and was the first to detect starch in the cells; and the accuracy of his remarks was fully confirmed by Ralfs, Jenner, and other recent algologists. It is said that no starch is to be detected in the young cell, while upon the growth of the sporangium, or spore capsule, it appears and increases rapidly, as in the seeds of the higher plants, in which it generally abounds. Of all the circumstances which indicate the vegetable nature of the desmidieæ, this is the most important, since it can be so easily submitted to experiment. In certain cavities in *closterium* Dalrymple noticed a peculiar motion of molecules on which he laid some stress. This motion has been termed swarming, on account of the commotion which arises within the cell; as the disturbance increases, the cell opens, when the molecules, or rather germinative cells, dart about in every direction, until at length they settle down into repose. The presence and functions of these cells in plants of entirely differing families and groups, render their occurrence in those under consideration no evidence of their being animals. The desmidieæ resist decomposition, exhale oxygen on exposure to the sun, preserve the purity of the water containing them, and when burned do not emit the peculiar odor usually so characteristic of animal combustion. Berkeley, in his "Introduction to Cryptogamic Botany," remarks that if in some points there be anomalies, as in *closterium*, their whole history is so evidently vegetable, their mode of increase, growth, &c., that if we refuse them the title of vegetables, we may as well dispute that of the whole tribe of protophytes. The fact that under the influence of light they give out oxygen, added to the other characteristics, is quite convincing.—Considering the desmidieæ as vegetable productions, we find them peculiar for their beauty, variety of forms, and external markings and appendages. They are mostly of an herbaceous green color, and contain a green internal matter. The frond divides into two valves or segments, by a sort of voluntary action; a mode of growth in the bisection of cells that Meyen and others have proved to be frequent if not universal in the more simple algæ. In the desmidieæ the multiplication of the cells by repeated division is full of interest. The compressed and deeply constricted cells of *euastrum* offer most favorable opportunities for ascertaining the manner of this division; for although the frond is really a single cell, yet this cell in all its stages appears like two, the segments being always distinct. As the connecting portion is so small, and necessarily produces the new segments, which cannot arise from a broader base than its opening, these are at first very minute,



though they rapidly increase in size. The segments are separated by the elongation of the connecting tube, which is converted into two roundish hyaline lobules. These lobules increase in size, acquire color, and gradually put on the appearance of the older portions. Of course, as they increase, the original segments are pushed further asunder, and at length are disconnected, each taking with it a new segment to supply the place of that from which it has separated. All the desmidiæ are gelatinous. In some the mucus is condensed into a distinct and well defined hyaline sheath or covering; in others it is more attenuated, and the fact that it forms a covering is discerned only from its preventing the contact of the colored cells. In general, its quantity is merely sufficient to hold the fronds together in a kind

third generation acquire their regular form, which they may continue to propagate for years, without ever producing a true spore.—Very little is known respecting the uses of the desmidiæ. The food of bivalve mollusks belonging to fresh waters seems to be made up of them. They are found principally where there is some admixture of peat, and in clear pools rather than in running streams. They abound in open places, and are rarely seen in shady woods or in deep ditches. So numerous are the species and so diversified their shapes and characters, that they have been divided into distinct genera as natural series present themselves in turn. In the first of these series we discover the plant an elongated, jointed filament, which may be cylindrical, sub-cylindrical, triangular or quadrangular, plane with the margins even and smooth, or with the margins incised and sinuated. In *hyalotheca* we have the mucous envelope alluded to above, within which are numerous joints, which are usually broader than long; and as each has a shallow groove passing round it, it resembles a small pulley wheel. The minuteness of the plant may be estimated from the length of these joints, which vary from  $\frac{1}{1000}$  to  $\frac{1}{100}$  of an inch. *H. dissiliens* (Bréb.) is found in North America as well as in Europe. In *desmidium* the joints are bidentate at the angles; the filament is fragile and of a pale green color; the length of the joint is from  $\frac{1}{2000}$  to  $\frac{1}{1000}$  of an inch. *D. Swartzii* (Ag.) is common throughout the United States. In *micrasterias* we have a simple, lenticular frond, deeply divided into two-lobed segments, each lobe incised-dentate and generally radiate. Many species of this beautiful plant are common in this country. The compressed bipartite and bivalved frond of the *xanthidium* is represented in the fossils by one that is globose and entire. The constriction about the middle of the frond is lost in *closterium*, which also differs in shape, it being crescent-like or arcuate. The species of this are common and numerous. The fronds of *ankistrodesmus* are aggregated into faggot-like bundles. *Pediastrum tetras*, occurring from Maine to Virginia, has an extremely minute frond composed of four cells, which make a star-like figure; while *P. biradiatum*, found in New Jersey as well as in Germany, has many more cells, yet still arranged in a stello-radiate manner.—In collecting the desmidiæ, the student must seek in proper situations the sediment observable in the form of a dirty cloud or greenish scum upon the stems and leaves of filiform aquatic plants. This is to be carefully transferred to a bottle of pure water, and thus he will secure many beautiful species for his microscope. If the bottle be exposed to the light, the little plants will continue in good condition, and thrive for several months.

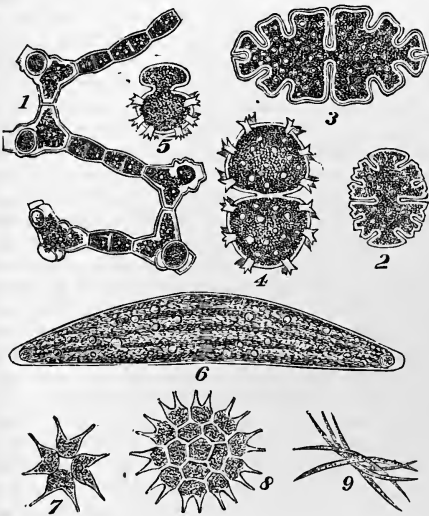

1. *Didymoprium Borreri*, with the cells uniting to form the green matter. 2. *Micrasterias crenata*. 3. *Euastrium oblongum*. 4. *Xanthidium armatum*. 5. The same with a frond acquiring a new segment by division. 6. *Closterium lunula*. 7. *Pediastrum tetras*. 8. *Pediastrum biradiatum*. 9. *Ankistrodesmus falcatus*.

of filmy cloud, which is dispersed by the slightest touch. When they are left exposed by the evaporation of the water, this mucus becomes denser, and is apparently secreted in larger quantities to protect them from the effects of drought. Their normal mode of propagation seems to be by the production of single large spores or sporangia, which derive their existence from the union of the green coloring matter (endochromes) of two contiguous plants. This process is seen in the sketch of one of the species of *didymoprium*, in fig. 1 of the cut. These spores are mostly globular, although they exhibit a great variety of forms with reference to their external surfaces. Sometimes they bear no resemblance to the parent plant. But once formed, they are propagated by division, in the same manner as the ordinary cells, and in the

**DES MOINES**, a S. E. county of Iowa, bordering on Illinois, washed by the Mississippi on the E., bounded S. by Skunk river, and

drained by Flint creek; area, 408 sq. m.; pop. in 1870, 27,256. Limestone and anthracite are the principal mineral productions. The surface is occupied by prairies and tracts of timber. The soil is fertile and well cultivated. The Burlington and Missouri River, the Burlington, Cedar Rapids, and Minnesota, and the Burlington and Southwestern railroads traverse it. The chief productions in 1870 were 211,234 bushels of wheat, 887,138 of Indian corn, 208,833 of oats, 98,269 of potatoes, 24,457 tons of hay, 478,878 lbs. of butter, and 69,859 of wool. There were 8,350 horses, 6,558 milch cows, 10,931 other cattle, and 15,426 sheep; 2 flour mills, 4 planing mills, 3 breweries, 3 manufactories of agricultural implements, 15 of carriages and wagons, 1 of cars, 3 of machinery, 2 of marble and stone work, 1 of linseed oil, 1 of sashes, doors, and blinds, 1 of tobacco and snuff, 4 of cigars, and 2 of woollen goods. Capital, Burlington.

**DES MOINES**, a city and the capital of Iowa and county seat of Polk county, situated at the head of steam navigation on Des Moines river, at its junction with the Raccoon, about 300 m. W. of Chicago; pop. in 1850, 502; in 1860, 3,965; in 1870, 12,035; in 1873, 15,061. The city is laid out in quadrilateral form, extending 4 m. E. and W. and 2 m. N. and S. The Des Moines, flowing from the north, divides it a little E. of the centre, and the portion W. of this river, commonly called the "West Side," is again divided S. of its centre by the Raccoon. From the confluence of the rivers, on either side, the ground rises gradually toward the city limits to a height of about 160 ft. Enclosed by the rivers on the south and east is a plateau about 1 m. long and  $\frac{1}{2}$  m. wide, with an average elevation of 15 ft. above high water, where are situated the post office, court house, and city offices, the principal depots and hotels, and the greater portion of the business houses. On the higher ground beyond are some of the finest private residences. E. of Des Moines river is another business locality. The portion of the West Side S. of Raccoon river is known as "South Park." Capital square, E. of the river, contains 10 acres, on an elevated site, commanding a fine view. The old capitol was erected by the city in 1856, at a cost of \$60,000. Provision was made by the legislature in 1869 for the erection of a new capitol, to cost \$1,500,000, of which the foundation has been laid. The post office, which accommodates also the United States courts, the land office, and other federal offices, was built in 1870, at a cost of over \$200,000. The driving park association possesses grounds, about 100 acres in extent, situated in a bend of Raccoon river, which are provided with suitable buildings for holding the state and county fairs, &c. A public park in the N. W. part of the city, containing 40 acres of native forest, has recently been set apart. The rivers are spanned by six bridges. The Chicago, Rock Island, and Pacific, and the Des Moines

Valley railroads intersect here. A branch of the former is in operation to Indianola and Winterset, and several other roads are in progress. Wood is abundant in the vicinity. There are also extensive coal mines, and deposits of fire clay, potters' clay, lime, &c. The city contains a woollen factory, several plough factories, scale works, an oil mill, founderies, flour mills, two national banks with a capital of \$200,000, and one life and two fire insurance companies. Gas works were constructed in 1865. Water works have been erected by a private corporation, with city aid; the water is obtained from Raccoon river, and is distributed through 10 m. of mains. Des Moines is divided into seven wards. There are five public school houses; the number of separate schools in 1872 was 22 (including a high school), having 24 teachers, and an average attendance of 1,018 pupils. The Baptists have a college, occupying a four-story brick building, 80 by 250 ft., situated on an eminence affording a fine view of the city and the valleys of the rivers. The state library contains about 15,000 volumes, and there is a public library with about 3,000 volumes. Three daily newspapers, six weekly, and six monthly periodicals are published here. There are 15 churches, viz.: Baptist, Christian, Congregational, Episcopal, Lutheran, Methodist (3), Presbyterian (3), Roman Catholic, and Universalist. The Spiritualists also have a society.—Des Moines was laid out in 1846, and incorporated as the town of Fort Des Moines in 1851. A city charter, giving it its present name, was granted in 1857, and the same year it became the capital of the state.

**DES MOINES RIVER**, the largest river in Iowa, formed by the junction of two branches, known as the E. and W. forks, which rise in a chain of small lakes in S. W. Minnesota, and flowing S. E. unite in Humboldt co., Iowa. From the junction it flows S. E. through the middle of the state, and joins the Mississippi at the S. E. corner, about 4 m. below Keokuk, having for a short distance formed the boundary between Iowa on the N. E. and Missouri on the S. W. In its course of 300 m. the Des Moines drains 10,000 sq. m. in Iowa, passing through an undulating, fertile region, interspersed with tracts of prairie, rich in coal, and abounding in timber. There are many excellent mill sites along its banks. The fall from Fort Dodge, Webster co., to Ottumwa, Wapello co., is 2 ft. 4 in. per mile, and from Ottumwa to its mouth, 1 ft. 11 in. per mile. Many towns have sprung up along its banks, among which is Des Moines, the state capital. The principal tributaries from the west are the Raccoon, or Coon river, and North, Middle, and South rivers; the largest E. branch is the Boone, which rises in Kossuth and Hancock counties. Raccoon river rises in Buena Vista co., receives several tributaries, and empties into the Des Moines at the city of the same name. An appropriation of lands to improve the naviga-

tion of the Des Moines was made by congress, but it was afterward diverted to the construction of the Des Moines Valley railroad. Before the diversion, however, a number of dams had been built in the lower part of the stream, which afford good water power.

**DESMOND, Earls of**, an ancient family of great influence in S. W. Ireland, between 1329 and 1583. The line numbered 15 earls. The title and family are now extinct. Before the English gained a footing in Ireland, the kingdom of Cork was a separate sovereignty, embracing much of the present province of Munster. It was divided into Desmond or South Munster, Muskerry or West Munster, and Carbery in the southwest. In 1172 Dermot MacCarthy, king of Cork, swore fealty to Henry II., but soon afterward broke his plight and attacked his liege's forces. He was overpowered, and Henry in 1177 bestowed the kingdom on Robert Fitz Stephen and Milo de Cogan. Cogan's share, falling ultimately to co-heiresses, was divided between Robert Carew, Patrick Courcay, and Maurice Fitz Thomas. The last was created by the English monarch earl of Desmond in 1329. By aggressions on the lands of Courcay and Carew, and by other acquisitions, the estates of the Desmonds so increased that the 8th earl was possessor of almost the whole of the former kingdom of Cork. He exercised rights of sovereignty with such a high hand that he was attainted of treason, and beheaded at Drogheda, Feb. 15, 1467. His estates, being suffered to remain in his family, continued to augment until Gerald, the last earl, owned a territory extending 150 miles through the counties of Waterford, Cork, Kerry, and Limerick, and comprising 500,000 acres. These earls never yielded more than a nominal allegiance to the English crown. The country of the Desmonds was Irish in language, habits, and religion. Hence it was deemed a favorable locality by Philip II. of Spain, in his war with Queen Elizabeth, to attempt the conquest of Ireland. Accordingly, on July 1, 1578, a body of Italian troops, under the command of James Fitz Maurice, brother of the earl of Desmond, and accompanied by Saunders, the pope's legate, landed in the Desmond country, where they were immediately joined by Sir John of Desmond and James Fitzgerald, other brothers of the earl. At first Earl Desmond made some show of resistance, but subsided at length into neutrality. On this, Lord Justice Pelham summoned him to surrender his castles to the queen. Desmond refused, whereon he and all of his name were proclaimed traitors, Nov. 1, 1579. Desmond now summoned his people to support the Catholic cause, and his dependants responded to the call. He seized on the town of Youghal, and until November, 1583, maintained a determined warfare. Being by that time driven from his strongholds, one after another, he wandered over the country for months, and was at last killed in a cabin where he had

taken shelter. His estates were divided among the captains of Elizabeth's army. Sir Walter Raleigh received 20,000 acres, which he sold cheaply to Richard Boyle, afterward earl of Cork.—**JEANNE FITZGERALD**, wife of James, 14th earl, is said to have lived to an age exceeding 140 years. Her husband presented her at the court of Edward IV., where she danced with the duke of Gloucester, afterward Richard III.; she was widowed during the reign of Edward IV., and died in the reign of James I., some time after 1603. At the age of 140 she travelled from her home at Inchiquin, Ireland, by the way of Bristol, to London, to urge some claim against the government. At that time she was quite vivacious and in possession of all her faculties. Sir Walter Raleigh says, "I myself knew her." ("History of the World," book 1, ch. 5.) Bacon mentions that the old countess of Desmond had thrice renewed her teeth. Recent investigators, however, have thrown much doubt on her alleged great age.

**DESMOULINS, Benoît Camille**, a French revolutionist, born at Guise in Picardy in 1762, guillotined in Paris, April 5, 1794. He studied law in Paris, but never practised. On the eve of the revolution he published two republican pamphlets, *La philosophie au peuple français* (1788), and *La France libre* (1789); and when the revolution broke out he ardently adopted its principles, and became one of the favorite orators of the crowd which gathered at the Palais Royal to hear the news of the day. On July 12, 1789, the day after the dismissal of Necker, he mounted a table in the garden of the palais and called the people to the defence of their threatened liberty; he declared that he would not be deterred from speaking by fear of the police, and with a loaded pistol in each hand swore that he would not be taken alive. He advised the patriots to wear a green badge, and as there was not a sufficient quantity of ribbon, he gave them the green leaves of the trees in the garden. The cry "To arms!" was raised; the crowd seized upon all the arms they could find at the gunsmiths', and forming in procession carried through the streets the bust of the dismissed minister with that of the then popular duke of Orleans. The next day the muskets and cannon at the Invalides fell into the hands of the people, and on the 14th the Bastille was taken. Camille, who had given impulse to this insurrection, figured among the combatants, and at once gained popularity. This was enhanced by a pamphlet, *La lanterne aux Parisiens*, in which he styled himself the "attorney general of the lamp post." Its success encouraged him to commence, under the title of *Les révolutions de France et de Brabant*, a newspaper which exercised great influence by its vigor of thought, sparkling wit, and lively style. Such was its importance that Mirabeau sought to conciliate its editor. Camille had been a schoolmate of Robespierre, and lived on

intimate terms with the future dictator of the revolution. He was also acquainted with Marat. But his bosom friend was Danton, who largely controlled the young and brilliant writer. Their destinies were closely connected from the establishment of the club of the Cordeliers. Camille was instrumental in the insurrection of Aug. 10, 1792, and was appointed secretary to the ministry of justice when Danton received that office from the legislative assembly. In the massacre of September he used his influence to preserve the lives of several intended victims. With Danton he was elected to the national convention. In the contest between the Girondists and the Montagnards, he contributed to bring the former into contempt by his *Histoire des Brissotins*, a pamphlet in which ridicule was skilfully blended with serious charges. He was satisfied with the fall of the party, and would have saved the individuals of whom it was composed, but this was beyond his power. Both he and Danton now tried to bring the convention to a milder policy, and toward the end of January, 1794, Camille established a journal, *Le vieux Cordelier*, in which he advocated conciliatory measures. Denouncing the system of proscription, he demanded the establishment of a committee of clemency as a preliminary step to clearing the prisons of the suspected. This was answered by accusations brought against him in the club of the Jacobins. Robespierre defended his old friend on two occasions; he represented Camille as a wayward child, whose person it was not necessary to injure, but demanded that his writings should be burned. "To burn is not to answer," exclaimed the headlong journalist; and from that day his fate was sealed. He was arrested on the same night with Danton (March 30), arraigned with him before the revolutionary tribunal, and, without a hearing, was sentenced to death. When asked his age, he replied, *Trente-trois ans, l'âge du sans-culotte Jésus, l'âge funeste aux révolutionnaires*. On their way to the scaffold, while Danton stood composed and immovable, Camille became almost frantic, struggling with his bonds, and appealing to the people. His friend vainly motioned him to keep quiet; he continued to address the crowd, and recalled to their memory all that he had done in their service. "Behold," he cried in despair, "behold the recompense reserved to the first apostle of the revolution!" His young and beautiful wife, who had vainly implored his pardon from the old friendship of Robespierre, tried to raise a riot to save him, but she was arrested, and suffered death a few days later. Camille Desmoulins holds high rank as a pamphleteer. His *Vieux Cordelier* was reprinted in 1833.

**DESNA**, a river of Russia, which rises in the government of Smolensk, flows through those of Orel and Tchernigov, and falls into the Dnieper a few miles above Kiev. It is a fine stream, abounding in fish, and navigable

for the greater part of its course of about 500 miles.

**DESNOYERS, Auguste Gaspard Louis Boucher**, baron, a French engraver, born in Paris, Dec. 20, 1779, died there, Feb. 15, 1857. At the age of 20 he received a prize of 2,000 francs for an engraving of Venus disarming Cupid, and in 1801 established his reputation by the reproduction of Raphael's "Beautiful Gardener," in the gallery of the Luxembourg. His most admired productions are copies of Raphael's works, and prominent among them is an engraving of the "Transfiguration." He was elected a member of the institute in 1816, appointed chief engraver to the king in 1825, created baron in 1828, and officer of the legion of honor in 1835.

**DESOR, Edward**, a Swiss geologist and naturalist, born at Friedrichsdorf, Hesse-Homburg, Feb. 11, 1811. He studied law at Giessen and Heidelberg, was compromised in the republican movements of 1832-'3, and escaped to Paris. Here his attention was drawn to geology; he made excursions with Élie de Beaumont, and in 1837 met Agassiz at a meeting of naturalists in Neuchâtel, and with Gressli and Vogt became his active collaborator, contributing the essays for vol. iii. of his *Monographie d'échinodermes vivants et fossiles* (Neuchâtel, 1842). He also published *Excursions et séjours dans les glaciers et les hautes régions des Alpes de M. Agassiz et de ses compagnons de voyage* (Neuchâtel, 1844). After spending a few years in the north of Europe, especially in Scandinavia, investigating the erratic phenomena peculiar to that region, he accompanied Agassiz in 1847 to the United States, found employment in the coast survey, and made with Whitney, Foster, and Rogers a geological survey of the mineral district of Lake Superior. Returning to Neuchâtel in 1852, he investigated with Gressli the orography of the Jura for industrial purposes, and was appointed professor of geology. He published subsequently *Geologische Beschreibung der neuchâtelers Jura* (with Gressli); *Synopsis des échinides fossiles* (Paris, 1857-'9); and *De l'orographie des Alpes dans ses rapports avec la géologie* (Neuchâtel, 1862). Having been made a citizen of the community of Ponts, he was elected a member of the grand federal council, of which he became president. In the winter of 1863 he visited Algeria and the Sahara, and published *Aus Sahara und Atlas* (Leipsic, 1865). The discovery of the lake dwellings induced him to pursue the study of archæology, and the results of his researches are given in *Les palafittes, ou constructions lacustres du lac de Neuchâtel* (Paris, 1865; German, Leipsic, 1866). The most important of his recent publications is *Échinologie helvétique* (Paris, 1869-'71), prepared in conjunction with Lorient.

**DE SOTO, I. A. N. W.** county of Mississippi, bordering on Tennessee, and bounded N. W. by the Mississippi river; area, 960 sq. m.; pop.

in 1870, 32,021, of whom 17,745 were colored. The surface is generally level, and occupied chiefly by cotton plantations. There are extensive swamps in the W. part. The Mississippi and Tennessee railroad crosses it. The chief productions in 1870 were 25,048 bushels of wheat, 741,363 of Indian corn, 72,977 of sweet potatoes, 191,543 lbs. of butter, and 24,118 bales of cotton. There were 4,359 horses, 4,468 mules and asses, 6,648 milch cows, 10,334 other cattle, 4,760 sheep, and 36,315 swine. Capital, Hernando. II. A N. W. parish of Louisiana, bordering on Texas, drained by Red and Sabine rivers; area, 910 sq. m.; pop. in 1870, 14,962, of whom 9,851 were colored. By means of the Red river it has steamboat communication with New Orleans. The chief productions in 1870 were 321,365 bushels of Indian corn, and 15,809 bales of cotton. There were 1,334 horses, 1,618 mules and asses, 3,110 milch cows, 8,221 other cattle, 4,906 sheep, and 8,620 swine; 7 saw mills and 4 manufactories of carriages and wagons. Capital, Mansfield.

**DE SOTO, Fernando**, a Spanish explorer, born at Xeres de los Caballeros, in Estremadura, about 1496, died on the banks of the Mississippi in 1542. Of a noble but reduced family, he was enabled by the favor of Pedrarias Davila to spend several years at one of the universities, and distinguished himself in literary studies, and especially in athletic accomplishments. In 1519 he accompanied his patron on his second expedition to America as governor of Darien, and was the most intrepid opponent of the oppressive administration of that officer. He supported Hernandez in Nicaragua in 1527, who perished by the hand of Davila in consequence of not heeding his advice. Withdrawing from the service of Davila, he explored in 1528 the coast of Guatemala and Yucatan for 700 m., in search of the strait which was supposed to connect the two oceans. In 1532 De Soto joined Pizarro in his enterprise for conquering Peru. Being sent in 1533, with 50 horsemen and a few targeteers, to explore the highlands of Peru, he penetrated through a pass in the mountains, and discovered the great national road which led to the Peruvian capital, and was soon after selected by Pizarro to visit the inca Atahualpa as ambassador. After the capture of the inca, and when the latter had paid an immense sum for ransom, De Soto in vain expostulated with Pizarro for treacherously refusing to release the Peruvian monarch. He was prominent in the engagements which completed the conquest of Peru, and was the hero of the battle which resulted in the capture of Cuzco, the metropolis. He soon after returned to Spain with a fortune of \$500,000, met a flattering reception from the emperor Charles V., made a splendid display at court, and married the daughter of Davila, to whom he had been long attached. In 1536 the belief was entertained that in the vast region then called Florida was a new El

Dorado, richer than any that had been discovered. De Soto proposed to the emperor to undertake the conquest of Florida at his own expense; and the privilege being conceded to him, many Spanish and Portuguese cavaliers enrolled themselves among his followers. With 600 men, 24 ecclesiastics, and 20 officers, he sailed from San Lucar early in April, 1538. After stopping at Santiago de Cuba, and then at Havana, where it was decided that the ladies attached to the expedition should remain till after the conquest of Florida, he crossed the gulf of Mexico, and anchored in the bay of Espiritu Santo (Tampa bay), May 25, 1539. His route was through a country already made hostile by the violence of the Spanish invader Narvaez, and he was constantly deluded by the Indians, whose policy it was to send their unwelcome visitors as far away as possible by telling them of gold regions at remote points. A Spaniard, Juan Ortiz, who had been in slavery here from the time of Narvaez, served as his interpreter. In July, 1539, he sent back all his ships to Havana. He passed the first winter in the country of the Appalachians, E. of the Flint river. Directed then to the north-east, he reached in April, 1540, the Ogeechee; thence proceeding S., he reached the Coosa, and on Oct. 18 the village of Mavilla or Mobile, on the Alabama. In an engagement with the natives here the loss of the Spaniards was 80 men and 42 horses; that of the Indians was reported at 2,500 men. He passed the second winter in the country of the Chickasaws, who in the spring burned his camp and their own village, when he attempted to force them to carry his baggage; 40 Spaniards perished in the flames and in the night attack. Soon after beginning his march to the northwest a pestilential fever carried off nearly a score of his men. He reached the Mississippi after journeying seven days through forests and marshes, was nearly a month in constructing eight barges to transport his army, and having crossed the river went N. to Pacaha, where he remained from June 19 to July 29. Thence he marched successively S. W. and N. W. till he reached the highlands of the White river. This was the western limit of his expedition. He then proceeded S. by the hot springs of Arkansas, and made his third winter station at Autiamque on the Washita river. In March and April, 1542, he continued S. along the Washita to the Mississippi, and while attempting to descend the banks of the latter river he was attacked with fever and died, after appointing Luis de Moscoso his successor. The day of his death is variously given as May 21 and June 5 and 25. To conceal his death, his body was wrapped in a mantle and sunk at midnight in the middle of the stream. His followers, reduced more than one half in number, venturing east, were driven backward to the river, where they passed the next winter. In the spring of 1543 they embarked in seven boats, and after nearly three months the survivors reached the Mexi-

can town of Panuco, where they dispersed. De Soto's wife expired at Havana on the third day after learning his fate.

**DESPARD, Edward Marcus**, an Irish soldier, born about 1755, beheaded in London, Feb. 21, 1803. He was a native of Queen's county, Ireland, served in the army with credit, and reached the rank of lieutenant colonel. He was superintendent of the English colony in Honduras, and in consequence of complaints against him was recalled in 1790, but could never procure an examination into his administration. This made him disaffected, and he was arrested for seditious conduct; but after his liberation he was only the more inflamed. In conjunction with some privates of the guards and a number of workmen he formed a plan to seize the tower and the bank, and to assassinate the king on his way to open parliament. The conspirators were tried by special commission at Southwark, Feb. 5, 1803, and Despard and nine of his associates suffered death.

**DES PLAINES**, or **Aux Plaines** (Indian appellation, *She-shik-mah-o*), a river of Illinois, rising in the S. E. part of Wisconsin, flowing S. and S. W., and uniting with the Kankakee at Dresden, Grundy co., to form the Illinois. It is about 150 m. long, and derives its name from a species of maple called by the French *plaine*.

**DESSAIX, Joseph Marie**, a French general, born in Thonon, Savoy, Sept. 24, 1764, died Oct. 26, 1834. He studied medicine at Turin and commenced practice in Paris, but returned to Savoy in 1791, organized an association to propagate democratic principles, and was made captain of a corps of volunteers formed by this association. He served at the siege of Toulon, and in Italy under Bonaparte; was elected in 1798 to the council of 500, where he opposed the *coup d'état* of the 18th Brumaire; made a brigadier general by Bonaparte in 1803, and, in the campaign of 1809 against Austria, a general of division, receiving from the emperor the surname of *l'Intrepide* and the title of count of the empire. Being wounded during the expedition to Russia, he was put in command of the city of Berlin, and in 1813 was intrusted with the defence of France on the line of the Alps. In 1814 he was kindly treated by the Bourbons, notwithstanding which he joined the standard of Napoleon after his landing at Cannes, and was imprisoned six months in 1816. After the revolution of 1830 he was elected commander of the national guard at Lyons.

**DESSALINES, Jean Jacques**, emperor of Hayti, born in W. Africa about 1760, killed Oct. 17, 1806. He was brought to Hayti as a slave, and adopted the name of his master. The repeal, Sept. 24, 1791, of the rights of citizenship conferred on people of color by the French national assembly, was followed by a contest between the mulattoes and the planters. During this conflict Dessalines served under Jean François on the side of the mulattoes. The commissioners of the French convention having in August, 1793, proclaimed universal freedom, Toussaint

*l'Ouverture* went over to their side. Dessalines followed his fortunes, was made successively colonel and brigadier general, and played an important part in the expulsion of the English from the island. Gen. Leclerc having been sent by Napoleon to Hayti to reestablish slavery, the negroes on his arrival in 1802 took up arms, and Dessalines was made general of division and placed in command of the department of the west. One of his most remarkable feats during the campaign which followed was the defence of the town of St. Marc against Gen. Boudet. When unable to hold out any longer he burned the town, setting fire with his own hand to a palace which he had just constructed for himself. Though obliged to retreat, he kept up the fight for a considerable time, but was finally forced to surrender. A truce was concluded, May 1, 1802, and while it was still in force Toussaint *l'Ouverture* was seized and carried to France. The negroes thereupon renewed the conflict, and Dessalines was made commander-in-chief. The French army was attacked by the yellow fever; Leclerc died; and the French were compelled to evacuate the island. Hayti proclaimed its independence, Jan. 1, 1804, and Dessalines was appointed governor general for life. He issued a proclamation in which he rehearsed the grievances Hayti had suffered from the French, and undertook to exterminate the whites who still remained upon the island. On Oct. 8, 1804, he had himself crowned as emperor of Hayti, assuming the title of Jean Jacques I. A constitution was adopted, and he seemed for a time anxious to promote the welfare of his people, and put forth several schemes for the encouragement of immigration of negroes from the United States and Jamaica. But he soon relapsed into cruelty; a conspiracy was formed against him, and he fell into an ambuscade and was killed. He had great courage and considerable military ability, but in other respects was little more than an ignorant savage, and proved himself one of the most brutal and bloodthirsty monsters that ever wielded power over their fellows.

**DESSAU**, a city of Germany, capital of the duchy of Anhalt, on the river Mulde, 2 m. from its junction with the Elbe, and 67 m. S. W. of Berlin; pop. in 1871, 17,464. It is the ducal residence, and has a fine park and a picture gallery. The theatre, the palace of the hereditary prince, the council house, the castle church, the government building, the gymnasium, St. Mary's church with some pictures by Lucas Cranach the younger, and the fine cemetery, are the most attractive features of the town. There are many scientific, artistic, religious, and industrial institutions and societies, a commercial school, a high school for girls, a ducal library containing about 25,000 volumes, an orthopaedic institution, and a bank with a capital of about \$2,000,000. The manufactures embrace woollen, linen, and cotton fabrics, musical instruments, hats, leather, and tobacco.

An important wool market is held here, and a flourishing trade in grain and other produce is carried on. Its environs are adorned with beautiful gardens, which have been reclaimed from sandy wastes.—Dessau was noted as early as 1213, and in 1313 had a school independent of the church. It was destroyed by fire in 1467. In the German revolution of 1848 it was one of the most democratic cities of Germany.

**DESSOLLES**, or **Dessolle**, **Jean Joseph Paul Augustin**, marquis, a French soldier and statesman, born at Auch, Oct. 3, 1767, died near Paris, Nov. 4, 1828. He early entered the army, was captain in the mountain legion in 1792, provisional adjutant on the staff of the army of the western Pyrenees in June, 1793, and chief of staff in October, and served in the Italian campaign under Bonaparte. He was appointed brigadier general May 31, 1797, commanded successfully against the Austrians in the Valtellina in 1799, and was promoted April 13 to the rank of division general. He took part in the battles of Novi, Möskirch, Biberach, Neuburg, and Hohenlinden. After the peace of Lunéville in 1801 he was made councillor of state and became provisional commander of the army of Hanover. In 1805 he was made governor of the château of Versailles. He became commander of a division of the army in Spain in 1808, occupied Cordova in January, 1810, and was made military governor of the city. On April 2, 1814, he received from the provisional government the command of the national guard of Paris, and contributed largely to the decision of the allies in favor of the Bourbons. On the arrival of the count d'Artois at Paris Dessolles was made a member of the provisional council of state, and upon the organization of the government he was appointed minister of state and major general of the national guards, and a peer of France. Upon the return of Napoleon he took the most energetic measures against him. During the hundred days he remained in retirement, and upon the return of the Bourbons resumed command of the national guards, but soon resigned. He was afterward minister of foreign affairs, and was elected president of the council of ministers Dec. 28, 1818. At the same time he was made a marquis. He opposed in the council the proposed change in the law of elections in 1819, and in November resigned, with the two ministers who shared his views.

**DESTERRO**, **Nossa Senhora do Desterro**, or **Santa Catharina**, a city of Brazil, capital of the province of Santa Catharina, on the W. coast of the island of that name, in lat. 27° 30' S., lon. 48° 30' W., 465 m. S. S. W. of Rio de Janeiro; pop. about 8,000. The city is on a tongue of land projecting into the bay, and is defended by two forts. It has many well built residences, but the streets are very irregular and badly paved. The public buildings are nearly all ill constructed and unsightly. Next to that of Rio de Janeiro, the harbor is the best on the coast; but its situation on an island is a serious disadvan-

tage. A thunder storm and water spout in 1838 destroyed a considerable portion of the town.

**DESTOUCHES**, **Philippe Nérieault**, a French dramatist, born in Tours in 1680, died July 4, 1754. After leading an adventurous life with a company of strolling players, he was entertained at Lausanne by M. de Puisieux, the French envoy to Switzerland. His first comedy, *Le curieux impertinent*, was performed there with great applause in 1710, and was scarcely less successful when it appeared at Paris. Some other plays of his, among them *L'Irrésolu*, attracted the attention of the regent duke of Orleans, who employed him in several foreign missions. After his return from London in 1723, on the death of the regent, he retired to his country seat near Melun, where he wrote a number of comedies, the best of which are *Le philosophe marié* and *Le glorieux*, performed with great success in 1727 and 1732. In his later years he devoted himself to theology, and published several essays against infidelity. His collected works were published in 1750, in 4 vols. 4to.

**DESTUTT DE TRACY**. **I. Antoine Louis Claude**, count de Tracy, a French philosopher, born at Paray-le-Frésil, near Moulins, Bourbonnais, July 20, 1754, died at Auteuil, March 9, 1836. At the desire of his father, who was a general, he entered the army, and was a colonel at the outbreak of the revolution. He was a member of the provincial assembly of Bourbonnais, and was elected as delegate of the nobility to the states general, Jan. 24, 1789. Here he was a leader in reform measures, attacking the monarchy and the privileges of the nobility. Upon the dissolution of the assembly he retired to his estate at Auteuil; but in 1792 he was appointed *maréchal de camp* and joined the army under Lafayette, with whose moderate views he fully sympathized. After the events of Aug. 10 he followed him beyond the frontier, but soon returned privately to France, where he was arrested Nov. 2, 1793, and imprisoned till some time after the death of Robespierre. During this time he developed a taste for metaphysics, and became known as a philosopher. He was a member of the national institute from its formation, and as secretary of the committee of public instruction helped reorganize the public schools. After the 18th Brumaire he was made one of the first senators. In 1814 he voted for the fall of the empire, and entered the royalist chamber of peers; he protested against the reactionary measures of 1815. The departure of the national policy from his views, together with bereavement and personal sickness, brought upon him in old age a profound melancholy, and he became almost blind. He was a disciple of Condillac, and with clear and earnest convictions carried his materialism to its last extreme. His *Grammaire générale* (Paris, 1803) applies his philosophy to the analysis of language; his *Logique* (1805) applies it to the rules of reasoning, and has been considered a masterpiece;

and his *Traité de la volonté* (1815) applies it to the motives and results of our actions. These different parts of his system he afterward united under the title *Éléments d'idéologie* (4 vols. 8vo, 1817-'18). His *Commentaire sur l'Esprit des lois* he sent (before its publication in 1819) to President Jefferson, who translated it for a college text book (published in Philadelphia, 1811). Among his other works are *Quels sont les moyens de fonder la morale chez un peuple?* (Paris, 1798), and *Observations sur le système actuel de l'instruction publique* (1801). **II. Alexandre César Victor Charles**, marquis de Tracy, son of the preceding, born in Paris, Sept. 9, 1781, died at Paray-le-Frésil, Allier, March 13, 1864. He served in Napoleon's campaigns, became colonel in 1814, and retired in 1820. He was afterward for many years member of the chamber of deputies, distinguishing himself as an earnest liberal, and was minister of marine under Louis Napoleon from December, 1848, to October, 1849, when he joined the opposition. He protested against the *coup d'état* of Dec. 2, 1851, and retired to his estate at Paray. He was the author of *Lettres sur la vie rurale* (1861; previously published as *Lettres sur l'agriculture*, 1857). **III. Sarah Newton**, marchioness de Tracy, wife of the preceding, born at Stockport, England, Nov. 30, 1789, died at Paray-le-Frésil, Oct. 26, 1850. She was great-grand-niece of Sir Isaac Newton, and was brought to France in 1790. At the time of her marriage with the marquis de Tracy (1816) she was the widow of Gen. Letort. Wishing to settle her religious convictions, she acquired a knowledge of patristic Latin, and left writings which were published after her death, under the title of *Essais divers, lettres et pensées de Mme. de Tracy* (3 vols., 1852-'5), only 150 copies being printed.

**DETMOLD**, a city of Germany, capital of the principality of Lippe-Detmold, on the right bank of the river Werre, 46 m. S. W. of Hanover; pop. in 1871, 6,469. The old portion of the town is very poorly built; the new is regularly laid out and well built. It is surrounded by a wall pierced by three gates, and contains a fine palace of ancient date. It has a gymnasium, a normal school, a female high school, a large public library, and one of the best poorhouses in Germany. The manufactures are chiefly of leather, woollens, linen, and beer; and there are marble and gypsum quarries. Near the town was fought the battle in which Arminius destroyed the Roman army under Varus, A. D. 9; and also a battle between Charlemagne and the Saxons in 783. The former is commemorated by a copper statue 45 ft. high on a pedestal of solid sandstone 90 ft. high, erected by the German princes in 1838.

**DETROIT** (Fr. *détroit*, the narrows), a port of entry and the chief city of Michigan, capital of Wayne co., situated on the N. W. side of Detroit river, about 7 m. from Lake St. Clair, and 18 m. from Lake Érie, 80 m. E. S. E. of

Lansing, 225 m. W. by S. of Buffalo, and 250 m. E. by N. of Chicago; lat. 42° 20' N., lon. 82° 58' W. The city extends along the bank of the river about 7 m., and is built up for about 2½ m. from the water. For at least 6 m. the river front is lined with mills, dry docks, ship yards, founderies, grain elevators, railway depots, and warehouses. The ground on which the principal part of the city is built rises gradually from the river to the height of from 20 to 30 ft., at a distance of 15 to 30 rods from the shore; it then sinks slightly, and again rises gradually to the height of 40 to 50 ft. above the river. The river here is about ¼ m. wide, and has an average depth of about 32 ft., and a velocity of about 2 m. an hour. It gives to the city the best harbor on the great lakes. Fort Wayne, about a mile below, commands the channel. Belle Isle, at the head of the river, is a favorite resort for picnics. Grosse Pointe, projecting into Lake St. Clair a few miles above the city, is noted for its cherry orchards, and is the terminus of a beautiful drive. Grosse Isle, near Lake Érie, contains many fine residences. Put-in-Bay island, in the lake, near the mouth of the river, famous as the scene of Perry's victory, Sept. 10, 1813, has become a summer resort. The population of Detroit has been as follows: in 1810, 770; 1820, 1,442; 1830, 2,222; 1840, 9,102; 1850, 21,019; 1860, 45,619; 1870, 79,577, of whom 35,381 were foreign born and 2,235 colored. Of the foreigners, 12,647 were natives of Germany, 7,724 of British America, 6,970 of Ireland, 3,284 of England, 1,637 of Scotland, and 670 of France. There were 4,969 persons, 10 years old and over, who could not write, of whom 4,117 were foreigners. There were 15,636 families and 14,688 dwellings.—Detroit is laid out upon two plans: the one, that of a circle with avenues radiating from the Grand Circus as a centre; the other, that of streets crossing each other at right angles; the result of which is a slight intricacy in certain quarters, and a number of small triangular parks. The avenues are generally 100, 120, or 200 ft. wide. The streets vary in width from 50 to 100 ft., and are for the most part abundantly shaded with trees. The principal streets are Jefferson avenue, parallel with the river; Woodward avenue, which crosses the former at right angles, and divides the city into two nearly equal parts; and Fort street, Michigan avenue, Grand River avenue, and Gratiot street, at various angles with Woodward avenue. West Fort street and Lafayette avenue are handsome streets. The Grand Circus, the principal park, is semicircular, and is divided by Woodward avenue into two quadrants, each containing a fountain. The Campus Martius, about ¼ m. from the Grand Circus, is an open space 600 ft. long and 250 ft. wide, which is crossed by Woodward and Michigan avenues, and from which radiate Monroe avenue and Fort street. Facing the Campus Martius on the west is the new city hall, a handsome structure 200 ft. long, 90 ft.



wide, 66 ft. high to the cornice, and 180 ft. to the top of the tower, completed in 1871 at a cost of \$600,000. It is built of sandstone, in the Italian style, and consists of three stories above the basement, with a Mansard roof. In the square fronting the city hall stands a monument in memory of the Michigan soldiers who fell in the civil war. Facing the Campus Martius on the north is the opera house, one of the largest and finest edifices of the kind in the country. The custom house, which also contains the post office, is a large stone building in Griswold street. The board of trade has a handsome building near the river. The Roman Catholic cathedral is the largest church edifice in the city. St. Paul's church (Episcopal) is noted for its self-sustaining roof, and the central Methodist and Fort street Presbyterian churches are fine specimens of architec-

ture. The convent of the ladies of the Sacred Heart, in Jefferson avenue, is a large and beautiful building. One of the most noteworthy structures is the Michigan Central freight depot, 1,250 ft. long and 102 ft. wide, consisting of a single room, covered by a self-sustaining roof of corrugated iron. Near it is the great wheat elevator of the company, the cupola of which commands a fine view. The principal cemeteries are Woodmere, on high ground 4 m. W. of the city; Elmwood, 2 m. E. of the centre of the city; and Mt. Elliot (Catholic), adjoining Elmwood; besides which there are a Lutheran and four Jewish cemeteries. Eight lines of railroad radiate from Detroit, viz.: the Michigan Central, extending to Chicago; the Lake Shore and Michigan Southern, to Buffalo and Chicago; the Detroit and Milwaukee, to Grand Haven; the Great Western of Canada, to



Detroit.

Niagara Falls; the Grand Trunk to Portland, Me.; the Detroit, Lansing, and Lake Michigan, to Howard City; the Detroit and Bay City, between those places; and the Canada Southern. Eight lines of street railroad, with more than 40 m. of track, intersect the city, and three lines of ferry boats ply across the river to Windsor on the Canadian side. There are seven steamboat lines, with 70 boats running to various points on the lakes.—The foreign commerce of Detroit, as shown by the report of the bureau of statistics, is exclusively with Canada, though a few vessels have loaded direct for Liverpool. For the year ending June 30, 1873, the imports amounted to \$1,900,228, the exports to \$2,818,408. There were entered and cleared 1,949 American vessels of 307,760 tons, and 1,522 foreign vessels of 489,596 tons. In the coastwise trade the entries were 1,184 steam vessels of 581,243 tons, and 2,022 sailing

vessels of 203,666 tons; clearances, 1,174 steam vessels of 568,131 tons, and 2,056 sailing vessels of 204,995 tons. There were 365 vessels of 78,546 tons belonging to the port; of which 188, of 27,828 tons, were sailing vessels; 120, of 35,849 tons, steamers; and 57, of 14,869 tons, barges; 17 vessels, of 4,180 tons, were built during the year. The imports from Canada included 33,672 bushels of barley, 40,478 of peas and beans, 629,101 lbs. of fresh fish, 53,456 dozen of eggs, and \$171,584 worth of wood. The exports consist chiefly of Indian corn, oats, wheat, lumber, railroad cars, cotton, hogs, bacon, ham, and lard. The domestic trade is important, large quantities of produce, chiefly from Michigan, passing eastward through the city. The following table exhibits the receipts, almost wholly by rail, for four years, of the principal articles of commerce, exclusive of those in transit not reshipped:

ARTICLES.	AMOUNTS.			
	1870.	1871.	1872.	1873.
Flour, bbls. ....	730,518	783,763	667,906	495,509
Wheat, bushels. . .	2,127,473	3,899,655	3,381,274	2,675,719
Corn, bushels. ....	411,093	1,152,885	1,646,732	1,758,519
Oats, bushels. ....	436,018	1,617,276	1,040,303	1,362,881
Barley, bushels. . .	378,029	364,839	363,652	398,728
Butter, lbs. ....	1,866,141	2,401,658	2,291,042	.....
Hides, lbs. ....	5,157,760	4,692,334	4,778,095	3,092,280
Dressed hogs, lbs. .	6,616,851	11,583,066	8,914,359	.....
Pork and lard, lbs. .	890,435	.....	1,054,213	.....
Lard, lbs. ....	693,266	4,803,674	4,362,555	.....
Cured meats, lbs. .	1,607,631	10,915,006	9,247,031	.....
Beef, lbs. ....	307,995	603,749	404,759	.....
Pork, bbls. ....	7,507	15,510	8,512	.....
Wool, lbs. ....	5,592,917	5,074,186	5,248,256	4,969,018
Cattle, number. ....	50,668	100,085	72,572	86,178
Hogs, number. ....	135,558	425,483	755,979	777,106
Sheep, number. ....	149,961	165,185	166,592	176,584

The amount of flour and grain in store Jan. 1, 1874, was: 4,850 bbls. of flour, 106,618 bushels of wheat, 39,718 of corn, 29,046 of oats, and 16,520 of barley. The receipts of apples in 1871 were 328,763 bbls.; in 1872, 91,334; in 1873, 84,880. The receipts of lumber in 1871 were 103,000,000 ft., of which 65,200,000 came by rail, 33,500,000 by lake, and 4,300,000 from Canada; in 1872 the receipts were 76,947,000 ft., of which 4,900,000 came from Canada. About 60,000 cattle were sold in the Detroit market during the year, valued at \$2,422,000; hogs sold, 160,000, value \$1,760,000; sheep sold, 120,000, value \$435,000; total value of live stock sold, \$4,617,000. The city contained 642 stores in 1871, and there were 27 incorporated companies, chiefly manufacturing, having an aggregate capital of \$3,391,500. The manufactures are important, and have been rapidly extended within a few years. The vicinity to the Lake Superior iron region has given especial prominence to the working of iron, which employs 31 establishments, having an aggregate capital of \$4,000,000, and an annual product of \$10,000,000. These include 3 blast furnaces, 2 steam forges, a car wheel foundry, a manufactory of iron bridges, 11 machine shops, 5 boiler shops, 2 stove foundries, a manufactory of plumbers' and gas fittings, and a safe factory; to which may be added the railroad repair shops, the two blast furnaces and extensive rolling mills at Wyandotte, belonging to Detroit capitalists, and unenumerated establishments in the city. Besides the very extensive Pullman car works, there are two railroad car factories, producing \$4,500,000 worth of cars annually; 12 saw mills, which in 1873 manufactured 44,138,000 ft. of lumber; 3 ship yards; numerous manufactories of woodwork, including several of chairs and furniture, 1 of organs, 2 of wooden ware, 1 of matches, several of boxes, of sash, doors, and blinds, &c., producing annually goods valued at about \$4,000,000. In and near the city are 22 brick yards, manufacturing about 54,000,000 bricks annually. There are 7 large flour mills, which in 1873 produced 212,000 bbls. of flour; about 60 breweries,

and distilleries, yielding 90,000 bbls. of beer annually; 16 tobacco factories, having an annual product of about \$4,500,000; a large number of cigar factories, 17 tanneries, 4 steam cracker bakeries, 4 large manufactories of boots and shoes, 1 of white lead, 2 of chemicals, 1 of hats, caps, and fur goods, and several of confectionery. The Detroit copper-smelting works annually produce over \$2,000,000 worth of ingot copper from Lake Superior ore. There are 3 national banks, with an aggregate capital of \$1,900,000; 3 state banks, capital \$350,000; and 4 savings banks, with \$390,000 capital, of which all but one do a general banking business also. The aggregate deposits, Oct. 1, 1872, were \$9,416,000. The Detroit fire and marine insurance company has a capital of \$150,000, the Michigan mutual life insurance company of \$100,000, and the Michigan health insurance and relief society of \$10,000.—The government is administered by a mayor and a board of aldermen of 22 members (two from each ward) elected by the people for a term of two years. There are a court held by the recorder, a police court, and a superior court of civil jurisdiction; and the circuit and probate courts for Wayne county, and the United States circuit and district courts for the eastern district of Michigan, are held here. Detroit has a police force consisting of about 100 men, under the control of a board of four commissioners appointed by the governor of the state. The fire department, managed by four commissioners, has seven steam fire engines, two hook and ladder companies, and a fire alarm telegraph. The water works, valued at \$1,221,752, are under the charge of five commissioners. The water is pumped from the river by three steam engines, having an aggregate capacity of 32,000,000 gallons daily, into the mains and a reservoir 1½ m. back, holding 10,000,000 gallons, and is distributed to every quarter of the city through 160 m. of pipe. The average daily consumption is 9,000,000 gallons. The city is furnished with gas by two companies, and has 1,137 street lamps. There are 40½ m. of paved street and 79½ m. of sewers. Many of the streets are paved with wood. The assessed value of property in 1872 was \$23,615,674; cash value, \$78,718,913; taxation for all purposes, \$785,248. The house of correction, with capacity for 450 prisoners, is used for the confinement of petty criminals. Directly opposite is a home for discharged female prisoners. The United States marine hospital, on the bank of the river, just above the city, commands a fine view of the Canada shore. The other principal charitable institutions are the Harper hospital, adapted for 500 patients, St. Mary's hospital (Catholic), St. Luke's hospital and church home (Episcopal), the German orphan asylum, the women's hospital and foundlings' home, the Protestant orphan asylum, St. Anthony's boys' orphan asylum (Catholic), St. Vincent de Paul's orphan asylum (Catholic), the free dispensary, the

home for the friendless, the retreat for the insane, and the Hebrew widows' and orphans' society. In the ladies' industrial school vagrant children are taught the elements of learning and industry. The public schools are under the control of a board of 22 inspectors (two from each ward), elected by the people for two years, who appoint the superintendent of schools. A school census is taken between Sept. 1 and Oct. 10 of each year. In 1871 there were 28,779 children between the ages of 5 and 20 years, of whom 13,699 did not attend school during the year, and 12,092 between 8 and 14 years of age. The schools are divided into five grades: the high school and senior grades, in each of which the course is three years, and the junior, secondary, and primary grades, in each of which the course is two years. The statistics for the year ending Dec. 31, 1871, are as follows: number of schools, 131, viz.: 1 high, 18 senior, 30 junior, 37 secondary, 43 primary, and 2 mixed; number of teachers, 170, of whom 8 were males; pupils enrolled, 11,866; average daily attendance, 7,749; value of school property, \$505,810. The receipts for the year ending April 1, 1872, were \$162,615 from the city appropriation for schools and school houses, \$13,054 from the primary school fund, and \$2,629 from other sources; total, \$178,298. The expenditures for the same period were \$192,024, of which \$76,413 were for teachers' wages, and \$61,703 for building and furnishing school houses. At the close of 1871 there were 22 school buildings, with accommodations for 8,517 pupils, and two nearly completed, which would raise the number of sittings to about 9,500. There are a German-American seminary, a German Lutheran school, and several Catholic schools. The Detroit medical college was organized in 1868, and the Detroit homœopathic college in 1871. The public library contains more than 20,000 volumes; that of the young men's society, about 12,000; the library of the mechanics' society, 4,000; and the bar library, 3,100. The newspapers and periodicals are: 8 daily (3 German), 3 tri-weekly, 14 weekly (3 German), 7 monthly, and 2 quarterly. Besides the opera house, there are the German Stadt theatre and 23 public halls. There are 64 churches, including 5 Baptist (1 French, 1 German, and 1 colored), 2 Christian, 2 Congregational, 7 Episcopal, 2 Jewish, 7 Lutheran (German), 10 Methodist (2 German and 2 colored), 1 New Jerusalem, 6 Presbyterian, 9 Roman Catholic (1 French and 2 German), and 1 Unitarian; also 1 Spiritualist and 2 Christadelphian societies. There are 12 mission Sunday schools (1 French and 1 German), having an average attendance of about 1,800, and 3 convents (1 German).—The site of Detroit was visited by the French as early as 1610; the first permanent settlement was made by a party under Antoine de la Motte Cadillac in 1701, when Fort Pontchartrain was built. In 1763 it passed into the hands of the Eng-

lish, and immediately afterward was besieged for 11 months by Pontiac in his attempt to expel the whites from that region. In 1778 it contained about 60 log houses, 300 inhabitants, and one Roman Catholic church. The same year the British erected a fort, at first called Fort Le Nault, but after the war of 1812 known as Fort Shelby, which remained till 1827. By the treaty of peace in 1783 Detroit was ceded to the United States, but the Americans did not take possession of it till 1796. It was destroyed by fire in 1805, one house only escaping. In 1807 the present city was laid out. During the war of 1812 it fell into the hands of the British by the surrender of Gen. Hull, but came again into the possession of the Americans in 1813, after the battle of Lake Erie. It was incorporated as a village in 1815, the government being vested in five trustees, and in 1824 a city charter was granted. Destructive fires occurred in 1836, 1840, 1848, and 1865. Upon the organization of the territory of Michigan in 1805, Detroit became the seat of government, and was the capital of the state from its admission into the Union (1837) till 1847.

**DETROIT RIVER**, a strait connecting Lakes St. Clair and Erie, and separating Canada from Michigan, about 22 m. long, and varying in breadth from 3 m. to less than  $\frac{1}{2}$  m. Its course from Lake St. Clair to just below Detroit is S. W., from which point it flows nearly due S. The total descent is about 2 ft. The river rises and falls with the level of the lakes it connects; the average annual variation is only about  $1\frac{1}{2}$  ft., and the extreme variation, from February, 1819, when it was the lowest, to July, 1838, when it was the highest ever known, was only about 8 ft. The principal island is Grosse Isle, near Lake Erie; there are several smaller ones, which are used as fishing stations, from which large quantities of white fish are caught. Rivière aux Canards, near Malden on the Canadian side, and the river Rouge near Detroit, small streams, are the principal affluents. As it has great depth of water and a strong and uniform current, the navigation of the Detroit is not affected by obstructions. The Canadian shore rises abruptly from the water to a height of from 20 to 25 ft., while the American shore is low, and in some places marshy.

**DEUCALION**, king of Phthia, in Thessaly, son of Prometheus and Clymene. According to tradition, being forewarned by his father of an approaching deluge, he built a ship in which he and his wife Pyrrha were saved from an inundation which destroyed all the rest of mankind. When the waters subsided, their vessel rested upon Mount Parnassus, and their first care was to consult the oracle of Themis as to how the world should be re-peopled. Being advised to throw behind their backs the bones of their mother, and interpreting mother to mean the earth, they cast stones behind them, from which sprang men and women.

**DEUEL**, an E. county of Dakota, bordering on Minnesota; area, about 650 sq. m.; pop. in 1870, 37. Its surface is broken by the Coteau des Prairies, and it is watered by several lakes and by affluents of the Big Sioux and Minnesota rivers.

**DEUTERONOMY** (Gr. *Δευτερονόμιον*, the repetition of the law, from *δευτερος*, second, and *νόμος*, law), the 5th book of the Pentateuch, containing the history of what passed in the wilderness during about five weeks (from the beginning of the 11th month to the 7th day of the 12th month), in the 40th year after the departure of the Israelites from Egypt. It recites to the people the events which had taken place in their history, and explains again the law which had been received at Sinai. According to the old traditional view, this book, like the four preceding books of the Pentateuch, was written by Moses, with the exception of ch. xxxiv. (the last), which gives an account of the death of Moses, and is supposed to have been written by the author of the book of Joshua, to serve as a point of transition to the latter book. Among the recent defenders of the authorship of Moses are Hengstenberg, Hävernicks, Delitzsch, Keil, and Moses Stuart. According to Ewald and Riehm, the book was written under Manasseh; according to Bunsen, under Hezekiah; according to De Wette and Lengerke, under Josiah. Ewald is of opinion that it was written by a Jew living in Egypt; according to Gesenius and Bohlen, it was the work of the prophet Jeremiah.

**DEUTZ** (Lat. *Tuitium*), an old town and fortress of Prussia, in the province of the Rhine, on the right bank of the Rhine, opposite Cologne, with which it is connected by an iron bridge; pop. in 1871, 11,881. Among its finest buildings are the ancient church of St. Heribert, the new Protestant church, and the cavalry barracks. It has manufactories of velvet, ribbons, glass and china ware, chemicals and machines, and an iron foundry. It has a good harbor, and a new impulse has been given to the trade of the town by the Cologne and Minden railway, which begins here. The fortifications were razed after the peace of Nimeguen in 1678, but were rebuilt in 1816, and have recently been enlarged. The town dates its origin from a castle built here in the 4th century by Constantine the Great.

**DEUX PONTS.** See ZWEIFBRÜCKEN.

**DEV.** See DEMONOLOGY.

**DEVENTER**, a fortified city of Holland, in the province of Overysse, on the right bank of the Yssel, 8 m. N. of Zutphen; pop. in 1868, 18,218. It has narrow streets, spacious market places, handsome public promenades, a large town house, a court house, a prison, a weigh-house, several churches, a synagogue, and various literary, educational, and benevolent institutions. It has an excellent harbor, a prosperous trade, and extensive manufactories of Turkey carpets, stockings, iron ware, &c. It exports annually about 600,000 lbs. of butter,

and 350,000 Deventer cakes, for which it is celebrated. It was one of the Hanse towns, and in the 16th century ranked next after Amsterdam among the cities of the northern Netherlands.

**DE VERE, Maximilian Schele**, an American author, born near Weixiö, in Sweden, Nov. 1, 1820. He entered the military and afterward the diplomatic service of Prussia, but emigrated to the United States, and in 1844 was appointed professor of modern languages in the university of Virginia. Besides frequent contributions to periodicals, he has published "Outlines of Comparative Philology" (1853), "Stray Leaves from the Book of Nature" (1856), "Studies of our English" (1867), "First French Reader" (1867), "Grammar of the French Language" (1867), "The Great Empress," a novel (1869), "Wonders of the Deep" (1869), "Introduction to the Study of French" (1870), "Americanisms" (1871), and "The English of the New World" (1873). He has translated into English Spielhagen's "Problematic Characters" (1869), "Through Night to Light" (1869), and "The Hohensteins" (1870).

**DEVEREUX.** See ESSEX, EARL OF.

**DEVIL, The** (Gr. *διάβολος*, the calumniator), in Christian theology, the sovereign spirit of evil. In the very earliest ages there appears to have been no distinct conception of any single spirit who was the embodiment of the evil principle. None of the divinities of the ancient Hindoos were supposed to exert a wholly bad influence. Their power was sometimes manifested for good, and sometimes for evil. In the post-Vedic period, though Siva the destroyer was one of the three great powers of nature, the exertion of his power was not necessarily evil. Kali, Siva's wife, and the Rakshasas, who were hostile to everything good, were gods whose nature partook of evil; but no single divinity represented in himself the evil principle. There was, however, such a divinity in the religion of ancient Persia. He was called Ahriman, and his power was represented as nearly equal to that of Ormuzd, the god of good, who reigned in heaven. Ahriman created devils and archdevils to resist the spirits that ministered to Ormuzd. The principles of this religion extended in some measure to the neighboring nation of the Chaldeans. The religion of the Semitic races was in its origin monotheistic. In it good and evil were alike caused by the supreme ruler. The religion of the Hebrews originally formed no exception. Even the Satan of the books of Job and Zechariah (the latter at least of late authorship) is a dependent spirit, in the service of God. But during or after the captivity the Jews borrowed from the Chaldeans or from the Persians the notion of a spirit who was the antagonist of all that is good and the personification of evil. In the gospels, written by Jews, the devil is represented as tempting Jesus to worship him. In the Christian theology, and the literature inspired by it, the devil

was conceived as a spirit who had once been good and had fallen. During the middle ages he was represented as having a black complexion, flaming eyes, sulphurous odor, horns, tail, hooked nails, and cloven hoofs. Such names as Devil's Dam, Devil's Bridge, &c., attest the belief in his actual interposition in human affairs.—The devil, as the ideal of evil, vice, craft, cunning, and knavery, has played a prominent part in literature. The following are examples: Fabricius, *Der heilige, kluge und gelehrte Teufel* (Esslingen, 1567); Musäus, *Der melancholische Teufel* (Tham, 1572); Velez de Guevara, *El diablo coxuelo* (Barcelona, 1646); Damerval, *Le livre de la diablerie* (Paris, 1508); *Le diable bossu, Le diable femme, Le diable pendu et dépendu, Le diable d'argent, Le diable babillard* (all early in the 18th century); *Le diable confondu* (the Hague, 1740); *Le diable hermite* (Amsterdam, 1741); *Le Sage, Le diable boiteux* (Paris, 1755); Frédéric Soulié, *Mémoires du diable* (Paris, 1842); "The Parlyament of Deuylls," printed by Wynkin de Worde (1509); "The Devill of Maseon" (Oxford, 1658); Defoe, "The Political History of the Devil, as well Ancient as Modern" (London, 1726); and Beard's "Autobiography of the Devil" (London, 1872). (See DEMONOLOGY.)

**DEVIL FISH**, a cartilaginous fish of the ray family, and the genus *Cephaloptera* (Duméril). In this genus the head is truncated in front, and provided on each side with a pointed, wing-like process, separate from the pectoral fins, and capable of independent motion; these processes, however, seem sometimes to be prolongations of the pectorals, and give the name to the genus, which signifies wings upon the head. The pectorals are of great breadth, triangular, resembling wings, and making the transverse diameter of the fish greater than the longitudinal, with the tail included; the jaws are at the end of the head, the lower the more advanced; the eyes are prominent and lateral; the tail is armed with one or two serrated spines, and is long and slender; in front of the spine is a small dorsal fin with 36 rays; the teeth are small, numerous, flat, and arranged in many rows; the small nostrils are placed near the angles of the mouth, and openings (probably the auditory) are situated on the dorsal aspect of the appendages to the head, behind the eyes; the branchial openings are five on each side, large, linear, near each other, the fifth being the smallest; the ventral fins are small, rounded, near the base of the tail; the skin is rough to the touch, like that of some sharks; the skeleton is cartilaginous. The old genus *Cephaloptera* has been divided by Müller and Henle, and the genus *Ceratoptera* added. In the first the mouth is on the ventral aspect, and the pectorals are prolonged forward to a point beyond the head, resembling horns; four species are described. In the second the mouth is at the end of the snout, the upper jaw is crescentic, and the under convex; there

are no teeth in the upper jaw, and they are small and scale-like on the under; the pectorals are separated from the precephalic fins by a rayless space; this includes three species, and among them, probably, the one mentioned below as caught at Kingston, Jamaica. The devil fish mentioned by Catesby, in his "Natural History of Carolina," is probably the same as the gigantic ray described by Mitchill in vol. i. of the "Annals of the Lyceum of Natural History of New York," under the name of the "vampire of the ocean" (*C. vampyrus*, Mitch.). This specimen was taken in the Atlantic, near the entrance of Delaware bay, in 1823, and was so heavy as to require three pair of oxen, a horse, and several men to drag it on shore; it weighed about five tons, and was 17½ ft. long and 18 ft. wide; the skin on the back was blackish brown, and on the belly black and white, and very slimy; the mouth was 2¾ ft. wide, the greatest breadth of the skull 5 ft., and the distance between the eyes 4¼ ft.; the cranial appendages were 2½ ft. long and a foot wide, tapering, supported internally

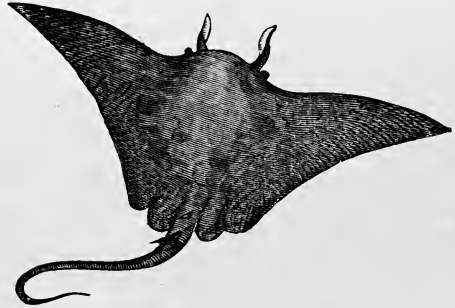

Devil Fish (*Cephaloptera vampyrus*).

by 27 parallel cartilaginous articulated rays, allowing free motion in almost all directions, and probably used as prehensile organs; the immense pectorals were attached to the scapular arch, and contained 77 articulated parallel cartilaginous rays, and were used like wings to fly through the water. The specific name of this ray was given by Mitchill from its size, representing in its family what the vampire does in the bat family. This specimen was again described by Lesueur in the "Journal of the Academy of Natural Sciences" (vol. iv., 1824), as *C. giorna* (Lacép.). Cuvier and De Kay consider the latter a distinct species, rarely exceeding the weight of 50 lbs. The devil fish is occasionally seen on the coast of the southern states in summer and autumn, and wonderful stories are told of its strength and ferocity, its extraordinary shape and size having transformed a powerful but inoffensive animal into a terrible monster. Other species are met with in the tropical parts of the Atlantic and Pacific, both in mid ocean and on sandy coasts, which they approach to bring forth their young. They are not uncommon in the West Indies, and Dr. Bancroft, in vol. iv. of the "Zoölogi-

cal Journal," describes one which was captured in 1828 in the harbor of Kingston, Jamaica, after a resistance of several hours, which dragged three or four boats fastened together at the rate of four miles an hour. In this specimen, which was smaller than the one described by Mitchill, the mouth was 27 in. wide, opening into a cavity  $4\frac{1}{2}$  ft. wide and 3 ft. deep, and so vaulted that it could easily contain a man. He named it *C. manta*, which is doubtless a synonyme of *C. vampyrus* (Mitch.). Anson and other writers have described a fish like a quilt, which wraps itself around a diver and squeezes him to death. The ray called devil fish undoubtedly gave rise to these stories, but it is anatomically impossible that it can so seize its prey, and it does not appear that any one has ever witnessed such an event. The pectoral fins of the devil fish are too thick at their base and anterior margin, and their cartilages are too rigid, to allow of their being so bent downward as to enfold a man or any other prey in the manner alluded to; they are composed of a great number of joints, more than 600, and must be capable of a considerable variety of motions calculated to impel the animal through the water with great strength and speed. The appendages to the head can hardly be used in locomotion. Lieut. St. John, who has watched attentively the movements of this fish, says these flaps are used in driving a large quantity of water toward the mouth when the animal is at rest, feeding; they can be bent in front of and even into the mouth, and are probably prehensile organs for various purposes; when swimming, the flexible ends are coiled up. The nature of the teeth and the narrowness of the gullet also render it improbable that this fish feeds upon anything but small fry, which it sweeps toward the mouth with its cranial flaps. The truth appears to be that the devil fish, though powerful and hideous, is a timid and harmless creature, avoiding rather than attacking man; but when attacked and defending itself, the serrated spine of the tail would prove a dangerous weapon, inflicting a deep, lacerated, and possibly fatal wound to man or fish within its range. They are gregarious, and are pursued by fishermen for the oil of the liver.—The *pieuvre* of Victor Hugo's *Travailleurs de la mer*, rendered "devil fish" in the English translation of that work, is a fictitious monster, the description of which applies to no species of the devil fish.—Another large and hideous fish, which is sometimes called sea devil or devil fish, is the *lophius piscatorius* (Linn.); this is described under GOOSE FISH. (See also OCTOPUS.)

**DEVILLE.** I. Charles Sainte-Claire, a French geologist, born on the island of St. Thomas in 1814. He studied at the school of mines in Paris, and wrote *Voyage géologique aux Antilles et aux îles de Ténériffe et de Fogo*, published in parts (Paris, 1856-'64). The great eruption of Vesuvius in 1855, which he wit-

nessed, called forth an interesting correspondence with Élie de Beaumont. He has long filled the chair formerly held by Beaumont at the collège de France. Among his latest publications is *Sur les variations périodiques de la température* (1866). II. Henri Étienne Sainte-Claire, a chemist, brother of the preceding, born on the island of St. Thomas, March 11, 1818. He studied in France, and devoted himself to chemical researches. After occupying for several years a chair of chemistry in the normal school, he succeeded Dumas in 1859 at the faculty of sciences in Paris. He discovered in 1849 the properties and preparation of anhydrous nitric acid, and published in 1852 an important paper on the metallic carbonates and their combinations. In 1853 he discovered a new method of mineral analysis, by means of gases and volatile reagents. About the same time he began his experiments with aluminum, and discovered a cheap method of producing it. He published his researches on the subject in his *De l'aluminium, ses propriétés, sa fabrication et ses applications* (Paris, 1859). He has since prepared several papers on a simplified general method for the production of simple metals, and on the variation of chemical affinities at different temperatures. (See DISSOCIATION.) He published in 1862 *Rapport à l'empereur sur la fusion de l'acier au four à réverbère sans emploi du creuset*, and in the following year *Métallurgie du platine et des métaux qui l'accompagnent* (3 vols. 8vo, with 3 charts).

**DEVIL'S ADVOCATE.** See ADVOCATUS DIABOLI.  
**DEVIL'S BRIDGE,** a remarkable stone bridge in the canton of Uri, Switzerland, near Ander-

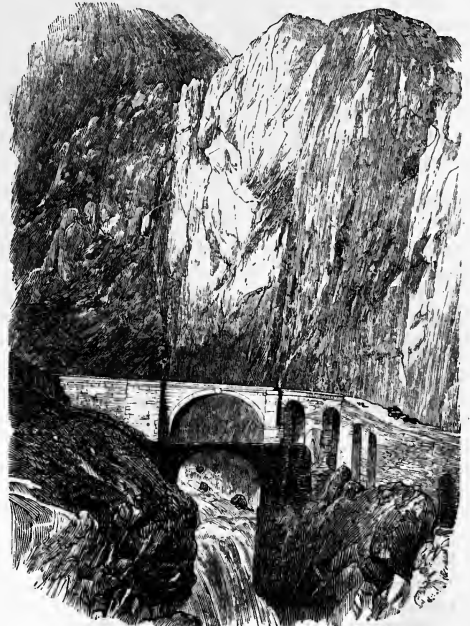

Devil's Bridge.

mat, by which the road from Switzerland to Italy by the pass of St. Gothard crosses the Reuss. The original bridge was built by Abbot Gerold of Einsiedeln in 1118, and was partly destroyed by the French, Aug. 14, 1799. It was afterward restored, but is no longer in actual use. It spans the river at a height of about 80 ft., without a parapet. The bridge now in use, completed in 1830, is about 20 ft. higher than the old one, or 100 ft. above the river, with high parapets; its arch has a span of 25 ft. Near the bridge is a tunnel 180 ft. long, through which the road passes, called the Urnerloch, or hole of Uri.

**DEVIL'S WALL**, a name given during the middle ages to the remains of some Roman fortifications designed to protect the settlements on the Rhine and the Danube against the inroads of the German tribes. These defenses originally consisted of a row of palisades, in front of which extended a deep ditch. The emperor Probus strengthened them by the erection of a wall about 300 m. long, passing over rivers and mountains, and through valleys, and protected by towers placed at intervals. Portions of this wall are still distinguishable between Abensberg in Bavaria and Cologne on the Rhine. In some places the ruins are overgrown with oaks, in others they form elevated roads or pathways through dense forests.

**DEVISE**, the disposition of lands to take effect after the death of the devisor. It is a term of Norman origin, and signified at first any division of lands, *marque de division ou partage de terres*, from the Latin *divido*. The instrument by which lands are devised is called a will. The disposition of personal estate to take effect after the death of the person making it is in legal language a testament; but the common appellation, where both real and personal estate are included, is last will and testament. The Roman *testamentum* applied equally to the disposition of real or personal estate, and the same rules were observed in either case. But the mode of executing a will has been always more formal in England than was required for the validity of a testament. (See **WILL**.)

**DEVIZES**, a parliamentary borough and market town of Wiltshire, England, on the Great Western railway and on the Kennet canal, 82 m. S. W. of London; pop. in 1871, 6,840. It contains two handsome parish churches, besides other places of worship, and a fine town hall. Its manufactures are chiefly silk, crape, snuff, and malt. The grain market held here every Thursday has been famous ever since the time of Henry VIII., and is still the largest in the west of England. The town is supposed to owe its origin to a strong castle built here in the reign of Henry I. by Roger, bishop of Salisbury, and dismantled toward the close of the reign of Edward III.

**DEVONIAN**, the name of one of the geologic ages, the age of fishes, and the second of the

three ancient or palæozoic divisions of time. It followed the Silurian, or age of mollusks, which till recently was thought to contain the earliest vestiges of organic life, and preceded the carboniferous. These three ages, constituting the palæozoic era, were followed by the age of reptiles, which constitutes the mesozoic era. The Devonian age, or Devonian formation, as the rocks are called, was named from Devonshire in England by Sir R. Murchison and Prof. Sedgwick, who about the year 1837 distinguished its strata from those of the Silurian below and the carboniferous above. The transition of the Silurian to the Devonian formation is gradual and easy, and sometimes rather difficult to determine; so much so that differences of opinion exist in regard to some of the strata in certain localities; but a broad distinction in the two ages is marked by the forms of the development of life. The periods and epochs into which the Devonian age is divided, according to the system of the New York state geologists, are as follows:

## DEVONIAN AGE.

- |                           |                              |
|---------------------------|------------------------------|
| 5. Catskill period.....   | Catskill red sandstone.      |
| 4. Chemung period.....    | { 2. Chemung epoch.          |
|                           | { 1. Portage epoch.          |
|                           | { 3. Genesee epoch.          |
| 3. Hamilton period.....   | { 2. Hamilton epoch.         |
|                           | { 1. Marcellus epoch.        |
|                           | { 3. Upper Helderberg epoch. |
| 2. Corniferous period...} | { 2. Schoharie epoch.        |
|                           | { 1. Cauda galli epoch.      |
| 1. Oriskany period.....   | Oriskany red sandstone.      |

The first and second periods are often called the lower Devonian, and those above, the upper Devonian. The corniferous was the great limestone period of America. Above it shales and sandstones predominate, the limestone beds being subordinate. The Oriskany formation, named from Oriskany, Oneida co., N. Y., is about 30 ft. thick at that place, composed mainly of rough sandstones. Along the Alleghanies it extends through Pennsylvania, Maryland, and Virginia, and in these states often reaches a thickness of several hundred feet. No land plants have been found among its fossils, and the mass of evidence points to the non-existence of land vegetation during the Oriskany period. The most common species of animals are the *spirifer arenosus* and *Rensselaeria ovoides*, their large fossil shells being often crowded together, and composing a good share of the rock. The *cauda galli* epoch of the corniferous period is named from the feathery forms of a fossil, supposed to be the impressions of a seaweed. The rock is principally argillaceous sandstone, and in the Helderberg mountains, near Albany, N. Y., is from 50 to 60 ft. thick. The rocks of the Schoharie epoch are principally fine-grained, calcareous sandstones, full of fossils. In New York the beds are all in the eastern part of the state. The rocks of the upper Helderberg epoch are limestones, and are widely distributed over the interior continental basin from New York to beyond the Mississippi. In New York they

are divided into Onondaga and corniferous limestone. This latter, from which the period takes its name, is called corniferous because it contains masses of hornstone or imperfect flint. The plants of this period are seaweeds and protophytes, the *cauda galli* being among the former. The upper Helderberg epoch is the coral reef period of the palæozoic ages, abounding in corals, some of which are found standing in the position in which they grew, but they are generally more or less comminuted. This formation attains in some places a thickness of 350 ft. The corniferous period is especially remarkable for containing the earliest discovered remains of fishes, the first development of vertebrate animals. The oldest development of them has been found in the United States, in the Schharie grit. The Devonian formation contains two of the great divisions of fishes, the salachians or sharks, and the ganoids, of which the gar-pike and sturgeon are representatives. The Marcellus shale of the Hamilton period is a soft argillaceous rock, containing sufficient traces of coal to afford a flame when placed in a fire. The Hamilton beds contain shale and flagging stone, and are overlaid by the black Genesee shale. The Hamilton beds are remarkable for containing numerous ripple marks, and for having the strata intersected by regular joints; fine examples of which are found near Cayuga lake, N. Y. These beds contain fine fossils of gasteropods, cephalopods, and trilobites. The Hamilton formation extends across New York from Lake Erie east, having its greatest thickness, about 1,200 ft., east of the centre. It extends into Michigan, Illinois, and Iowa, in thinner strata. The rocks of the Portage epoch of the Chemung period have a thickness of 1,000 ft. on the Genesee river, and of 1,400 ft. near Lake Erie, but are not found in eastern New York. The Chemung group extends over the southern tier of counties in New York, attaining in places a thickness of 1,500 ft. It abounds in organic remains, both vegetable and animal, containing, besides the *cauda galli* seaweed, numerous land plants, and many species of crinoids, brachiopods, conchifers, bellerophons, and goniatites. The last period of the Devonian formation, the Catskill, is composed mainly of shales and sandstones, the latter predominating, passing into conglomerates particularly in the upper formations. There are ripple marks and other signs of wave action. The vestiges of animal life are fewer than in the earlier periods, and widely differ from them in character. No corals, crinoids, brachiopods, or trilobites have been found. There are a few conchifers and fragments of fishes, some of which were of large size, the fins being a foot in length. The beds, however, have not been fully explored. The land plants are of much the same character with those of the Chemung period. A frond of one of the characteristic ferns, found at Montrose, Pa., was more than a foot in breadth. The Catskill formation is thin in the

western part of New York, but along the Hudson river, in the Catskill mountains, it attains a thickness of 2,000 or 3,000 ft. It passes beneath the coal formation in Pennsylvania and Virginia, attaining in the Appalachian region a thickness of 5,000 or 6,000 ft.—The Devonian rocks appear at the surface in most parts of all the continents; in Great Britain they appear in Wales, Herefordshire, Devonshire, and Cornwall, and are also found in Ireland and the Isle of Man; but they are most developed in the United States.

**DEVONPORT**, a parliamentary and municipal borough and naval arsenal in Devonshire, England, on the South of Devon railway, and on the Tamar, where that river makes a bold sweep toward the east and widens into the fine estuary called the Hamoaze, just before its entrance into Plymouth sound, 190 m. S. W. of London, and  $1\frac{1}{4}$  m. W. of Plymouth; pop. of parliamentary borough in 1871, 64,684. Its



Guildhall, Public Library, and Column to commemorate the Renaming of the Town.

harbor, one of several remarkable natural havens opening into the sound, is 4 m. long,  $\frac{1}{2}$  m. wide, from 15 to 20 fathoms deep, perfectly safe, and capable of sheltering the whole British navy at once; but it is difficult of entrance. The town is bounded S. and W. by the river, and E. by a creek which separates it from Stonehouse, contiguous to Plymouth. With these two places it is so closely connected that the three may almost be said to form a single city, and it was not till 1824 that Devonport acquired separate municipal privileges, and changed its old name of Plymouth Dock for its present one. Among its schools are a naval and military free school, and an institution in which 100 girls are educated and clothed. The town has a public library, orphan asylums, and a theatre. Water is brought from Dartmoor, in a winding con-



duit nearly 30 m. long. With the exception of some breweries and soap-boiling houses, Devonport contains no factories of importance. The density of the population is greater than that of any other place in England, viz., 130,000 to the square mile. Devonport is fortified on three sides by a wall, a breastwork, and a ditch 12 to 20 ft. deep cut in the solid rock; while the entrance from the sea is commanded by several heavy batteries. These works were begun by George II. The chief feature of the town is the dock yard, which employs 2,500 men. It was commenced by William III., who built the basin and two docks. It has a river front of 3,500 ft., and a maximum breadth of 1,600 ft., the area enclosed being about 96 acres. There are two dry docks, one double and one single dock for ships of the line, one graving dock, five building slips, and vast docks or basins at Point Keyham for fitting and repairing war steamers, commenced in 1844, and embracing an area of 72 acres. The immense roofs over the docks, consisting of single arches, without buttresses or pillars, are wonders of architectural skill. A canal 70 ft. wide runs nearly through the yard, communicating with the boat pond.

**DEVONSHIRE**, a maritime county of England, bounded N. and N. W. by the Bristol channel, W. by the river Tamar and Marsland Water, which separate it from Cornwall, S. and S. E. by the English channel, and E. and N. E. by Dorsetshire and Somersetshire; area, 2,589 sq. m.; pop. in 1871, 600,814. The principal rivers of Devon are the Taw, Torridge, Tamar, Dart, Teign, Exe, and Tavy. Trout are found in great plenty in most of these; the Tamar, Tavy, and Exe furnish valuable salmon fisheries, those of the last being thought the best in England. The county has three canals: the Great Western, 35 m. long, connecting the S. E. coast with the Bristol channel, the Tamar canal, and the Tavistock canal. The Bristol and Exeter and the South of Devon railways also traverse it. Devonshire is a rich mineral country, furnishing copper and lead in considerable abundance, with smaller quantities of tin, iron, bismuth, and many other minerals, besides coal and marble. The tin mines were anciently numerous and valuable, but are now nearly abandoned, those of Cornwall being so much richer. There are several varieties of lead ore, one of which is very rich in silver. Cobalt, antimony, and native silver have been found in considerable quantities. The marbles quarried from the limestone rocks on the E. and S. coasts much resemble Italian marble in texture and appearance. Fine pipe clay, potters' clay, and slate of excellent quality are abundant. The agriculture of Devonshire is in a flourishing condition, about three fourths of the land being under cultivation. The S. and S. E. parts contain extensive wastes, including Dartmoor, covered with immense rocks and detached masses of granite. In the N. and N. W. are found large tracts of swampy

ground and many peat bogs of great depth. The vale of Exeter, containing about 200 sq. m., is one of the richest valleys in the kingdom. The district called South Hams, extending from Torbay round to Plymouth, is known as the garden of Devonshire, and is finely diversified and very productive. The pasture lands are chiefly devoted to dairy uses, though some attention is paid to raising sheep and cattle. Devonshire is celebrated for its cider and its cattle. The purest breeds are distinguished by a high red color, without white spots; they are fine in the bone and clean in the neck, thin-skinned, and silky in handling; have horns of medium length bent upward, a small tail set on very high, a light dun ring around the eye, and are noted for feeding at an early age. The cows weigh from 420 to 460 lbs., the oxen from 700 to 820 lbs. The North Devon cattle, another variety, are in great demand for the firm grain of their meat, and the superior qualities of the oxen for work. The native horses are small, but hardy, and much accustomed to the packsaddle. Landed property in Devonshire is more evenly divided than in most other counties, there being few very large freeholds. Farms average from 100 to 200 acres. The spinning of linen yarn, and manufacture of linen goods, have superseded the former woollen manufacture. In and about Tiverton great quantities of lace and lace net are made, which find a market on the continent of Europe. Ship building gives employment to numbers of men. The chief ship yard is the royal dock yard at Devonport. The county town is Exeter, where the assizes are held. Among the other principal towns are Plymouth, Dartmouth, Tavistock, Okehampton, Totness, Honiton, Axminster, Tiverton, and Barnstaple. The county gives the title of duke to the Cavendish, and of earl to the Courtenay family. There are ruins, British and Roman, in various parts of the county, among which are several abbeys and castles.

**DEVRIENT**, the name of a family of German actors, of whom the most eminent are: **I. Ludwig**, born in Berlin, Dec. 15, 1784, died Dec. 30, 1832. His father, a silk mercer, intended him for a mercantile life, but at the age of 18 he joined a company of actors, and made his debut at Gera in Schiller's "Bride of Messina." He afterward travelled with the same company through Saxony, and in 1805 accepted an engagement at the court theatre of Dessau, and attained brilliant success. Pecuniary embarrassments drove him some years later from this place. He went to Breslau, and subsequently, at the suggestion of the actor Iffland, to Berlin, where in 1815 he appeared as Franz Moor in Schiller's "Robbers." From that time until his death he stood at the head of his profession in Germany. He was equally great in comedy and tragedy. **II. Karl August**, nephew of the preceding, born in Berlin, Aug. 5, 1798. He served in a regiment of hussars in the campaign of 1815 against

France, and was present at the battle of Waterloo; was afterward engaged in mercantile pursuits, and in 1819 made his *début* on the stage at Brunswick. In 1823 he married the celebrated singer Wilhelmine Schröder, from whom he was divorced in 1828. (See *SCHRÖDER*.) He acted in all parts of Germany, but was for many years established at Hanover. He was long celebrated for his spirited personation of leading parts in genteel comedy. **III. Philipp Eduard**, brother of the preceding, born in Berlin, Aug. 11, 1801. He commenced his artistic career as a baritone singer, but afterward appeared almost exclusively in the spoken drama. He was a careful and cultivated actor, a successful writer of dramas, and an authority on all that pertains to the profession. His chief works have been collected under the title of *Dramatische und dramaturgische Schriften* (8 vols., Leipsic, 1846-'61), including several plays, miscellaneous publications relating to the stage, and a history of the drama in Germany. **IV. Gustav Emil**, brother of the preceding, born in Berlin, Sept. 4, 1803, died in Dresden, Aug. 7, 1872. Like his two brothers and his uncle, he was intended for the mercantile profession, but in 1821 went upon the stage, where he soon gained distinction, assuming with success many of the parts, both in tragedy and comedy, with which his uncle Ludwig's name is identified. His wife, Dorothea Böhler, from whom he was divorced in 1842, was an excellent comic actress, and ably seconded her husband for many years. On Nov. 10, 1857, the 98th anniversary of Schiller's birthday, three members of the Devrient family, Gustav Emil, Karl August, and Karl's son, appeared together at Hanover, in the play of "Don Carlos." Gustav retired from the stage in 1867, having accumulated a large fortune; after which he wrote a history of the German stage, and an autobiography which was to be published after his death.

**DEW**, the humidity of the air, deposited on cool surfaces with which it comes in contact. It is commonly formed at night upon the leaves of grass and trees and other objects, especially when the sky is clear so as to permit sufficient radiation of heat from them to cool their surfaces, and consequently the layer of air next them, below the point of saturation, or dew point. The moisture which collects upon the surface of a cold body, as a pitcher of ice water, standing in a warm room, and that which collects on a window pane when it is breathed upon, are strictly examples of the deposition of dew, and also the frosted figures which form on windows and stone flaggings of courtyards and walks. In the latter case the solid surfaces have a temperature below the freezing point of water, and therefore the particles of moisture assume a crystalline form during the act of passing from their invisible vapory condition. The figures thus formed owe their variety to the varying degrees of temperature and moisture, and rapidity of deposition, and also to the nature of the surface of

the body and its thermal inequalities, which necessarily exist in curves. The different causes of the formation of dew were never clearly understood until the early part of the present century. The ancients connected its appearance with the intervention of supernatural powers. As it mysteriously appeared when the air was clear and apparently dry, and gathered upon the herbage in sparkling beads, while it avoided the barren and rocky surfaces, they might well look upon it as a special blessing, possessed of wonderful virtues. Hence it came to be prescribed for restoring the charms of youth, and to be used by the alchemists as a solvent of subtle and mysterious powers. The ancients generally entertained the idea that the moon and stars not only poured down cold upon the earth, but also, in some mysterious way, distilled dew. Aristotle was the first to approach a rational explanation, although, from a want of knowledge only obtained by the use of modern philosophical instruments, his explanations contained errors. He believed aqueous vapor to be a mixture of water and heat; and as it rarely appeared on mountain heights, he supposed it was abandoned by the heat, and left to precipitate itself upon the earth. He rejected the idea of lunar or astral influence, and maintained that the sun was the prime cause, "since his heat raises the vapor from which the dew is formed as soon as that heat is no longer present to sustain the vapor." In the middle ages philosophers revived the notion that the moon and stars were the cause of dew. Battista Porta showed the erroneousness of these views by instancing several facts, but he discarded the correct part of Aristotle's theory, that dew was condensed vapor separated from the atmosphere, and advanced the idea that it was condensed air itself. Musschenbroek observed that it was deposited more readily on some substances than on others, and therefore correctly inferred that the object itself had an important influence in its formation. This led to a reconsideration of Aristotle's theory, and its adoption, with the modification that instead of its being discharged from the mass of the air it was only removed from the stratum in contact with the object upon which it was deposited. The experiment of placing a cold body in a warm moist atmosphere proved the correctness of this theory. But it was not till a series of experiments were made by Dr. William Charles Wells (a London physician, though a native of Charleston, S. C.), and published in August, 1814, that a comprehensive theory of the formation of dew was publicly promulgated. His experiments were made in a garden in Surrey, near Blackfriars bridge, and will for ever remain as admirable examples of ingenious philosophical investigation. He exposed little pieces of dry wool of equal weights and sizes during the night, their increased weight in the morning showing the amount of dew which had been deposited. The quantity thus collected

was found to be greater on clear than on cloudy nights, but there was much difference in the amount deposited on different clear nights. He discovered that the quantity was less, not only when the air was drier, but also when the wool was covered by any kind of a screen, whether this was a board, a piece of cloth, a tree, or a cloud. Supporting a board a few inches above the ground and placing one piece of wool under and another upon it, each weighing 10 grains, he found that the upper piece gained 14 grains, while the under one gained only 4. He discovered, moreover, that when he used thermometers, the greatest deposition of dew always accompanied the lowest temperature; thus, he often found the temperature  $9^{\circ}$  or  $10^{\circ}$  lower above the board than under it, and on one occasion the thermometer fell  $14^{\circ}$  lower when freely exposed upon the grass than when suspended four feet above it. A piece of cotton in the vicinity of the latter place gained only 11 grains, while a piece of equal weight and size gained 20 grains lying upon the grass. The passing of clouds would cause the thermometer to rise and fall as they screened the locality or left it exposed to the clear sky. In consequence of the different capacities which bodies have of radiating heat, they attain different temperatures, and upon those which radiate and therefore cool the most rapidly, the greatest quantity of dew is deposited. Dr. Wells found that grass and wood were covered with it, while plates of metal, stones, and gravel walks were free from it. A glass thermometer placed upon a metal plate and exposed to the clear sky was, after a time, moist with dew, while the plate was dry. To ascertain whether this was caused by difference in position or external circumstances, he placed another thermometer having a gilt bulb beside the glass one, when the latter showed a temperature  $9^{\circ}$  lower than the other. This was because glass is a better radiator than metal, and therefore cools more rapidly.—The following synopsis of the attendant phenomena of dew is compiled from all the recorded observations.

1. The dew falls most abundantly during calm nights.
2. The drops deposited by fogs resemble dew, but differ in that fog wets all bodies indifferently, while dew attaches itself to some in preference to others.
3. Fogs may exist during winds; dew generally disappears if the wind rises.
4. Dew is deposited in preference on surfaces not protected by shelter from exposure to the clear sky.
5. Other things being equal, the quantity of dew deposited in a given time diminishes in proportion as the exposure to the sky is cut off by screens, whether they be above or on one side of the bedewed body.
6. The nature of a body, and especially the smoothness or roughness of its surface, affects the quantity of dew deposited on it. Thus, leaves of plants receive more than the earth, sand more than compact soil, glass more than metals; and in general substances that are poor conductors of heat, and

yet cool rapidly by radiation, such as glass, cotton, flax, hair, down, &c., are most heavily bedewed.

7. Dew is deposited during the entire night, beginning by or before sunset, and continuing until after sunrise; it forms most rapidly about sunrise.
8. A slight movement of the air is very favorable to the production of dew; but moderate or strong winds are not so, though they do not cause it to disappear entirely.
9. Fogs, haze, clouds, smoke, &c., act as do solid screens to diminish the deposition of dew; very low clouds accompanied by strong winds altogether prevent the dew.
10. The most abundant dews are observed on the shores of the oceans, lakes, rivers, &c.; the least abundant in the interior of dry continental plains, and on islands and ships in mid ocean. Ships approaching a coast soon begin to receive a deposit of dew. The clear cool nights of the western coasts of America and Palestine are peculiarly favorable to the formation of dew.
11. The accurate measurements of Wells show that as much as 20 grains of dew may be deposited in a single night on a surface two inches in diameter. Dr. Dalton estimates the entire amount of annual precipitation in England to equal five inches of rain.
12. The dew is heaviest in the first clear still night after long continued rain, and in general increases with the dampness of the air.
13. A very great difference of temperature between the air next to the ground and that a few feet above accompanies the formation of dew, especially when heavy.
14. The electrical condition of a body has no influence on its capacity for receiving dew.
15. Objects a few inches above the surface of the soil collect more dew than those lying on the ground itself. From all the preceding observations, Wells arrived at an understanding of the origin and the laws regulating the formation of dew; his conclusions are now, with slight modifications, very generally accepted. According to this view, the radiation of heat from the earth's surface into space, which is counterbalanced during the day by the reception of heat from the sun, takes place with most freedom through a clear, dry air, and is counteracted by screens, clouds, and fogs. The surface of a body exposed to unobstructed radiation into space loses its heat entirely, except in so far as this is supplied by conduction from the interior of its mass, or by convection through the action of sufficiently rapid currents of air. Thus it happens that the air in contact with the exposed surface of a bad conductor, but a good radiator, is cooled to the temperature of its dew point, and begins to deposit its moisture on the cold surface. If the air be absolutely motionless, only a slight deposit will be formed, and that very slowly; but by reason of the increasing density of the increasingly colder air the latter sinks, and is replaced by warmer air having the same humidity. Thus a continual supply of moist air is maintained, and this is favored by a very slight general movement of the air; while, on

the other hand, a strong wind conveys too much heat to allow of the cooling of the bedewed body. The hygrometric tables of Glai-scher, Regnault, and others, allow of an accurate prediction as to the quantity of dew that may be deposited, and even enable one to determine whether frost or dew will prevail. It will thus be seen that the true origin and nature of dew was quite misunderstood until early in the 19th century.—The DEW POINT is the temperature at which the vapor contained in the atmosphere condenses into water. It depends upon the amount contained within a given space; the greater this is, the higher will be the degree of heat necessary to retain it in a vaporous condition. When the air is saturated with vapor it is of course at its dew point, and any reduction of its temperature will cause the separation of a portion of moisture. As this process continues the dew point becomes gradually lowered, and although the proportion of moisture held in solution by the air diminishes, the degree of humidity remains the same; for this term is used not to denote the actual proportion of vapor, but the power of sensibly manifesting itself upon any given reduction of temperature. It is often called relative humidity, and is expressed in parts of 100, or the amount which would saturate the air at the particular temperature when the observation is taken. Thus, at Philadelphia the average humidity of the air is 73, meaning 73 per cent. of the quantity necessary for saturation; at St. Helena it is 88; at Madrid, 62; in parts of India it is sometimes as low as 10; and on the Andes it is often still lower. Air which is heated much above its dew point is regarded as dry, although it may contain a greater proportion of vapor than that which is called humid. In California the dew point is sometimes 78° below the temperature of the air, and among the Andes the difference is often greater. It has been found as much as 45° at Philadelphia, but the usual range is from 10° to 25°. The following table shows the mean relative humidity of the atmosphere in New York from several observations made each day at the Cooper institute, for the Smithsonian institution, by Prof. Morris:

Date, 1873.	Relative Humidity.	Temperature, Fahrenheit.	Date, 1873.	Relative Humidity.	Temperature, Fahrenheit.
Jan. 1	67-68	26°	June 1	59-13	76°
" 2	53-43	27-66	" 2	36-66	72-66
" 3	93-3	41-83	" 3	45-90	61-33
" 4	60-8	35-23	" 4	50-93	66-9
" 5	87-36	30	" 5	54	77-33
" 6	46-50	33-6	" 6	51-20	73-83
" 7	52-6	25	" 7	45-26	68-16
" 8	83-13	30-16	" 8	61-43	68-33
" 9	54-73	31-06	" 9	47-00	70-5
" 10	38-46	22-96	" 10	50-03	76-33
" 11	54-43	11-73	" 11	59-16	76-66
" 12	43-7	21	" 12	46-86	69-83
" 13	75	36	" 13	49-1	66-33

The difference between the dew point and the temperature of the air is called the complement of the dew point. From numerous observa-

tions which have been made with Daniell's and Bache's hygrometers, and with the wet-bulb thermometer, a method has been deduced for determining the dew point with sufficient accuracy, by observations made with the latter instrument. The ratio of the complement varies with the temperature of the air: thus, when it is 53° the difference between the dry and wet bulb is one half the complement; at 32° it is one third, and at 26° only one sixth. Tables have been constructed for readily determining the dew point, which may be found in the various works on meteorology. Thus, in the above table it is stated that the relative humidity of the air at New York, June 1, 1873, was 53-13, while the temperature was 76° F. By referring to the table of relative humidity in the article HYGROMETRY, it will be seen that the complement of the dew point was about 18°; that is, the dew point was about 18° lower than the temperature of the air, or about 58°. (See EVAPORATION, HEAT, and HYGROMETRY.)

**DEW, Thomas Roderick**, an American publicist, born in Virginia, Dec. 5, 1802, died in Paris, Aug. 6, 1846. He graduated at William and Mary college, and afterward travelled for two years in Europe. In 1827 he was chosen professor of moral science in William and Mary college, of which he became president in 1836. In 1829 he published "Lectures on the Restrictive System," and in 1833 an elaborate essay on "Slavery," which is said to have prevented emancipation in Virginia at that time. He died suddenly while on a visit to Europe with his bride. His most elaborate work is "A Digest of the Laws, Customs, Manners, and Institutions of Modern Nations," which appeared in 1853.

**DEWBERRY.** See BRAMBLE.

**DEWEES, William Potts**, an American physician, born at Pottsgrove, Pa., May 5, 1768, died in Philadelphia, May 18, 1841. He attended several courses of lectures at the university of Pennsylvania, and, without having taken any degree, in 1789 commenced the practice of medicine at Abington, Pa. The degree of M. D. was subsequently conferred on him by the university. The yellow fever having in the summer and autumn of 1793 thinned the ranks of the physicians in Philadelphia, in December of that year Dr. Dewees removed thither, selecting obstetrics for his specialty, and achieved a high reputation in that department. In 1812, being threatened with a pulmonary affection, he relinquished practice, and for five years devoted himself to agriculture. In 1817 he returned to Philadelphia. In 1826 he was elected adjunct professor, and in 1834 professor of obstetrics and diseases of women and children in the university of Pennsylvania. In the latter year he was attacked by paralysis, and at the commencement of the following year he was obliged to resign his professorship. He settled in Mobile, but resumed his residence in Philadelphia about a year

before his death. He published "Inaugural Essays," "Medical Essays," "System of Midwifery," "A Treatise on the Physical and Medical Treatment of Children," and "A Treatise on Diseases of Females." His last systematic work was his "Practice of Medicine," published in 1830.

**D'EWES, Sir Symonds**, an English antiquary, born in Coxden, Dorsetshire, Dec. 18, 1602, died April 18, 1650. He graduated at Cambridge, and was admitted to the bar, but never practised, and lived on his property at Stow Hall in Suffolk. He was high sheriff of Suffolk in 1639, was elected to parliament for Sudbury in 1640, and was one of the Puritan members expelled from the house of commons by "Pride's purge." He commenced collecting materials for a history of England at the age of 18, and though the fruits of his research were not published by him, they were of great use to Selden and other writers. After his death his "Journals of all the Parliaments during the Reign of Queen Elizabeth" (folio, London, 1682) was published by his nephew. His "Autobiography and Correspondence," edited by J. O. Halliwell (4 vols. 8vo, London, 1845), contains some interesting pictures of his times and contemporaries, intermixed with much that is useless and with a comical display of vanity.

**DE WETTE, Wilhelm Martin Leberecht**, a German theologian, born at Ulla, near Weimar, Jan. 14, 1780, died in Basel, June 16, 1849. Having studied at Weimar and Jena, he was appointed professor of philosophy, and subsequently of theology, at Heidelberg, and received in 1810 a professorship at the university of Berlin, where he rapidly acquired great reputation both as a teacher and as a writer. This situation he lost in 1819, in consequence of a letter of consolation written to the mother of Sand, the murderer of Kotzebue, which was regarded by the government as extenuating that political murder. He was afterward elected professor of theology in the university of Basel. His works are among the most remarkable productions of German theological science and criticism. The most important of them are: *Beiträge zur Einleitung in das Alte Testament* (2 vols., 1806-'7); *Commentar über die Psalmen* (1811); *Lehrbuch der hebräisch-jüdischen Archäologie* (1814); *Ueber Religion und Theologie* (1815); *Lehrbuch der christlichen Dogmatik* (2 vols., 1813-'16); "Critical and Historical Introduction to the Old and New Testaments" (2 vols., 1817-'26); the Introduction to the Old Testament was translated and enlarged by Theodore Parker, Boston, 1843, and that to the New by Frederick Frothingham, Boston, 1858); *Christliche Sittenlehre* (3 vols., 1819-'21); "Theodore, or the Sceptic's Conversion" (1822; translated by James F. Clarke, Boston, 1841); "Lectures on Practical Ethics" (1823; translated by Samuel Osgood, Boston, 1842); *Opuscula Theologica* (1830); *Das Wesen des christlichen Glau-*

*bens* (1846); a new translation of the Bible, executed together with Augusti, in 6 vols. (1809-'14); and an edition of Luther's works.

**DEWEY, Chester, D. D.**, an American clergyman, born at Sheffield, Mass., Oct. 25, 1784, died in Rochester, N. Y., Dec. 15, 1867. He graduated at Williams college in 1806, was licensed to preach in 1808, and during the latter half of that year officiated in Tyringham, Mass. The same year he accepted a tutorship in Williams college, and in 1810 was appointed to the chair of mathematics and natural philosophy, and occupied it 17 years. From 1827 to 1836 he was principal of the gymnasium at Pittsfield, Mass., and was also professor of chemistry in the medical colleges there and at Woodstock, Vt. In 1836 he became principal of the collegiate institute at Rochester, N. Y., and in 1850, on the establishment of the university of Rochester, he was elected professor of chemistry and natural history, from which position he retired in 1860. He was active in efforts for the advancement of public schools, and was for a time president of the teachers' institute. He made the study of grasses a specialty, and discovered and described several new species. In the class of *carices* he was a recognized authority, and his writings on this subject make an elaborate monograph, patiently prosecuted for more than 40 years. He was an extensive contributor to the "American Journal of Science and Arts," and wrote numerous papers on botany, and a "History of the Herbaceous Plants of Massachusetts," which was published by the state. His latest publications were two review articles, "The true Place of Man in Zoölogy," and "An Examination of some Reasonings against the Unity of Mankind." For nearly 50 years of his active life Prof. Dewey delivered an average of 70 sermons a year, though he was never a pastor.

**DEWEY, Orville, D. D.**, an American clergyman, born at Sheffield, Mass., March 28, 1794. He graduated at Williams college in 1814, studied divinity at Andover from 1816 to 1819, was for eight months agent for the American education society, and declined an immediate and permanent settlement on account of unfixed opinions in theology, but accepted a temporary call at Gloucester, Cape Ann, with a candid explanation of his unsettled views, and here became a Unitarian. He was soon after appointed assistant of Dr. Channing, preached two years in his pulpit, and formed with him an intimacy that lasted during Channing's life. In 1823 he accepted the pastorate of the Unitarian church in New Bedford, where he remained ten years, until, broken in health, he sought restoration in a voyage to Europe, June, 1833. "The Old World and the New" (2 vols., 1836) contains the history of his two years' absence. In 1835 he was called to the second Unitarian church in New York, which during his ministry built the "church of the Messiah," and became a very large and prosperous society. In

1842, his health again failing, he went abroad for two years, returned in 1844, and was compelled by continued ill health to dissolve his connection with his church in 1848, and retire to his farm in Sheffield, where he prepared a course of lectures for the Lowell institute at Boston, on the "Problem of Human Life and Destiny," which was repeated twice in New York, and delivered in many other places. This course was followed in 1855 by another Lowell course on the "Education of the Human Race," which was almost as widely repeated. Meanwhile he filled a Unitarian pulpit in Albany one winter, and in Washington two. In 1858 he was settled as pastor over the Unitarian society in Church Green, Boston, known as the "New South," from which after four years' service he returned to his home in Sheffield. The first book he published was a little work, which attracted much attention, entitled "Letters on Revivals." During his ministry at New Bedford he contributed to the "Christian Examiner" and the "North American Review." On leaving New Bedford he published a volume of sermons. His subsequent works have been collected and published in three volumes (New York, 1847); they consist of "Discourses on Human Nature," "Discourses on Human Life," "Discourses on the Nature of Religion," "Discourses on Commerce and Business," "Miscellaneous and Occasional Discourses," "The Unitarian Belief," and "Discourses and Reviews."

**DEWITT. I.** A S. county of Texas, drained by the Guadalupe river; area, 898 sq. m.; pop. in 1870, 6,443, of whom 1,757 were colored. It abounds in fine scenery, and has a hilly or rolling surface. The soil, particularly in the valley of the Guadalupe, is fertile. There are several medicinal springs, mostly sulphurous. The chief productions in 1870 were 107,896 bushels of Indian corn, 13,583 of sweet potatoes, 55,523 lbs. of butter, 21,275 of wool, and 541 bales of cotton. There were 5,520 horses, 5,547 milch cows, 53,832 other cattle, 17,232 sheep, and 7,226 swine. Capital, Clinton. **II.** A central county of Illinois, intersected by Salt creek; area, 675 sq. m.; pop. in 1870, 14,768. It is mostly level, and comprises forests of valuable timber and fertile prairies, remarkably easy of cultivation. Bituminous coal is the chief mineral product. The N. division of the Illinois Central railroad crosses it, and the Indianapolis, Bloomington, and Western railroad intersects the S. E. corner. The chief productions in 1870 were 118,185 bushels of wheat, 1,311,635 of Indian corn, 216,756 of oats, 88,120 of potatoes, 20,289 tons of hay, 341,456 lbs. of butter, and 96,916 of wool. There were 7,873 horses, 4,351 milch cows, 7,706 other cattle, 21,799 sheep, and 20,322 swine; 12 carriage factories, 1 flour mill, and 2 manufactories of saddlery and harness. Capital, Clinton.

**DE WITT, Jan,** a Dutch statesman, born in Dort in 1625, murdered at the Hague, Aug.

20, 1672. From his father, who had been a member of the states and a conspicuous opponent of the house of Orange, he inherited strong republican tendencies. The imprisonment of his father in 1650 intensified his hatred of the stadtholders; and the death of William II, in October of that year gave a favorable turn to the fortunes of De Witt. In 1652 he was one of the deputation sent to Zealand to dissuade that province from adopting the Orange policy, and the eloquence he then displayed gave him considerable popularity. In the following year he became grand pensionary of Holland; and his new power was at once exerted to the utmost to put an end to the plurality of offices which had rendered the stadtholders almost despotic. He so far succeeded that the office of stadtholder was abolished; and in negotiating the treaty of Westminster with Cromwell (1654), he procured the insertion of a secret article by which the house of Orange was to be forever excluded from the highest offices. When Charles II. was restored, De Witt sought to form an alliance with France; and England thereupon declared war against Holland. After hostilities had continued two years, the advantage was with Holland; De Ruyter's fleet was in the Thames and had burned the British shipping in the Medway, and the peace of Breda was concluded, July, 1667. Though De Witt managed the affairs of his office with great skill and wisdom during this war, his popularity sensibly declined, and the Orange party continually gained strength. When France assumed a hostile attitude toward Holland, he made such haste to form an alliance with Sweden and England that he had the treaty ratified at once by the states general, when it should have been referred to the council of each province. However this action may have been justified by the emergency, it was easy to make it a cause of popular clamor and distrust. Yet the grand pensionary did not abate his hostility to the house of Orange, or cease his efforts for regulating the finances and otherwise strengthening the internal condition of the government. Louis XIV. having succeeded in detaching England from the Dutch interest and forming a counter alliance, and his armies having invaded Holland in 1672, De Witt lost all hold on the confidence of the people, and was obliged to resign his office. William III. of Orange was made commander-in-chief of the Dutch forces, and was nominated stadtholder. De Witt's brother Cornelius, two years older than himself, had served with distinction in the navy for several years during his youth, was afterward appointed inspector of war vessels, and was again conspicuous under De Ruyter when the fleet entered the Thames. He was more celebrated, however, as a magistrate, and had risen to the office of deputy in the states general. The popular clamor excited against his brother was turned upon him also, and he was accused of plotting against the life of the prince

of Orange, and thrown into prison and tortured. On his release, Jan was waiting for him at the gate, when both were seized by a mob and murdered. The states general demanded an investigation of the affair; but the stadtholder neglected to do anything about it, and was therefore believed to have countenanced the assassination. The brothers, by their ability, courage, and integrity, had commanded the respect and admiration even of their political opponents. Jan was the author of several works of political interest.

**DEWSBURY**, a manufacturing town and parish of England, in the West Riding of Yorkshire, situated on the left bank of the Calder, and on the London and Northwestern railway, 28 m. S. W. of York; pop. in 1871, 24,773 (in 1851, 5,031). It is at the head of what is called the shoddy trade of England, vast quantities of refuse woollen rags, called "devil's dust," being collected from all parts of the kingdom and made into cloth, blankets, and carpets. About 3,000 persons are employed in these manufactures. There are collieries and iron works in the immediate neighborhood.

**DEXTER, Samuel**, an American statesman and jurist, born in Boston, May 14, 1761, died at Athens, N. Y., May 4, 1816. He graduated at Harvard college in 1781, and was admitted to the bar in 1784. After practising at various places in Massachusetts, he took up his residence in Boston. He was elected to the legislature of Massachusetts several times, and became a member of congress in 1793. In 1798 he was elected senator of the United States. He was appointed secretary of war by John Adams in 1800, and in 1801 secretary of the treasury, but returned to practice in 1802. He was a member of the federal party, but did not sympathize with it in regard to the war of 1812. In 1814 he was nominated by the republican party for the office of governor, on account of his opposition to the Hartford convention, but was defeated. He was the first president of the first temperance society in Massachusetts.

**DEXTRINE** (Lat. *dexter*, right; called also British gum, Alsace gum, starch gum, and torrefied starch), an isomeric condition of starch, having the composition  $C_6H_{10}O_5$  or  $C_{12}H_{20}O_{10}$ . It is also isomeric with gum arabic, which it much resembles in appearance and in many properties, but differs in the remarkable one, from which it derives its name, of turning the plane of polarization to the right when polarized light is passed through a solution of it, instead of to the left, which is the case when a solution of gum arabic is used. Starch will also turn the plane of polarization to the right, but in a much less marked degree than dextrine; the latter having an optical rotary power of  $138.68^\circ$ . Dextrine is an intermediate stage between starch and grape sugar, passing into the latter by combining with  $H_2O$ , but differing from starch in physical qualities only. Another intermediate modification between

starch and dextrine exists, according to Maschke and others, called soluble starch, which possesses a higher degree of right-hand polarizing power than dextrine and is turned blue by iodine. (See STARCH.) Dextrine may be produced by several processes. 1. By carefully roasting starch in shallow pans or revolving cylinders, heated between  $300^\circ$  and  $310^\circ$  F. When the starch presents a light brown color, and emits the odor of strongly baked bread, the transformation is effected. 2. By subjecting starch to the action of nitric acid. Payen's method was to mix 1,000 parts of dry starch with 2 parts of nitric acid of  $36^\circ$  Baumé, diluted with 300 parts of water, and place the mixture in layers about an inch thick on brass drawers in an oven heated to about  $240^\circ$  F. The transformation is effected in an hour and a half or two hours. 3. By boiling starch with dilute sulphuric acid, about 11 parts of water, 4 of starch, and 1 of sulphuric acid being used. The starch is stirred in part of the water, and the acid diluted with the remainder. Both portions are then raised to about  $194^\circ$  F. and gradually mingled; the temperature being maintained until as great a quantity as possible of dextrine is obtained, when the liquid is boiled to arrest the production of grape sugar, which is always formed in the process. The dextrine can only be obtained pure by repeatedly dissolving it in water and precipitating with alcohol. 4. By the action of diastase on starch. If 8 or 10 parts of malt are stirred in about 400 parts of water at  $80^\circ$  F., and the mixture is raised to about  $140^\circ$ , and then 100 parts of starch are stirred in, the temperature being again raised to  $158^\circ$ – $167^\circ$ , and there maintained for about half an hour, the starch will be converted into dextrine; but unless the temperature is changed the latter will pass into grape sugar. By raising the mixture to the boiling point, however, the transformation is arrested.—Dextrine, when pure, is solid, translucent, and uncrystallizable. It is ordinarily a brownish-colored powder, nearly tasteless, soluble in hot or cold water and in dilute alcohol, but insoluble in absolute alcohol. It is not colored blue, but red, by the action of iodine. When boiled with dilute acids and caustic alkalies, it is converted into glucose or grape sugar. If a small quantity of caustic potash is mixed with a solution of dextrine, and a dilute solution of sulphate of copper added drop by drop, the liquid will acquire a deep blue color, and will not yield a deposit while cold; but if heated to  $185^\circ$  F., it will be decomposed, with precipitation of oxide of copper. This test (Trommer's) distinguishes it from gum arabic. It has been found that the presence of dextrine prevents the blueing of starch by iodine, and will even discolor iodide of starch. Dextrine is used for stiffening cotton goods to prepare them for printing, and for sizing paper. It is a superior substitute for gum arabic, to give an adhesive layer to postage stamps and the

edges of envelopes; also to labels, particularly those for glass bottles, causing them to adhere more permanently than any other suitable substance. Confectioners employ it in the manufacture of lozenges. It is often employed with great advantage in the preparation of bandages to keep broken bones in perfect relative position. For this purpose it is generally used as crudely prepared by the action of sulphuric acid. Potato starch is generally used in the manufacture of dextrine, on account of its cheapness and greater purity.

**DEY**, throughout the 17th century the title of the commander of the armies of Algiers, subject to a pasha appointed by the Porte. At the beginning of the 18th century the dignity of pasha was united with that of dey, and the dey was the highest officer of Algiers from that time till the conquest of the country by the French in 1830. The deys were appointed and deposed by a council or divan, and the deposition of a dey was generally followed by his death. His nomination was announced to the Porte at Constantinople, which always confirmed it by a firman. The dey, who was also the commander-in-chief of the army and navy, exercised with his ministers all the executive authority; and the later deys took away the power of the divan.

**DEYRA DOON**, or **Dehra Doon**, a valley of British India, between the S. W. base of the lowest and outermost ridge of the Himalaya and the N. E. slope of the Sivalik mountains, the former having an elevation of 7,000 or 8,000 ft., and the latter of about 3,000; between lat. 30° and 30° 32' N., and lon. 77° 43' and 78° 24' E. It is bounded S. E. by the Ganges and N. by the Jumna, is drained by their tributaries, and with the hilly region called Jounsar Bawur forms a district under the lieutenant-governorship of the Northwest Provinces. The productions are rice, maize, grain, cotton, sugar, opium, indigo, plantain, and hemp. Every English plant is said to thrive luxuriantly, and considerable success has attended the cultivation of tea. The valley is watered by numerous streams, and abounds in game. The climate during part of the year is very unhealthy. The district was formerly included in the dominions of the rajah of Gurhwal, was overrun by the Gorkhas in 1803, and in 1815, during the Nepal war, was invaded by the British, who suffered great loss here, and who, after the expulsion of the Gorkhas, kept possession of the territory.—**DEYRA**, the principal town of the district, is situated in dense mango groves, at the intersection of two routes of trade, 2,369 ft. above the sea, and 125 m. N. N. E. of Delhi.

**DEZFUL**. See **DESFUL**.

**DHARWAR**. See **DARWAR**.

**DHAWALAGIRI**. See **HIMALAYA**.

**DHOLE**. See **DOG**.

**DIABETES**, *Glucosura*, *Diabetes Mellitus*, or *Glucosæmia* (Gr. *διαβαίνω*, to pass through), a disease characterized by an excessive secretion of

saccharine urine. Though disease marked by diuresis and attended with wasting of the body was frequently spoken of by earlier authors, Willis (1659) was the first who noted the distinctive character of the complaint, the presence of sugar in that fluid. Since his time diabetes, which is not very rare, has been frequently made a subject of study, yet still much obscurity envelops its causes, its essential character, and its treatment. The invasion of diabetes is commonly insidious. The attention of the patient is perhaps first attracted by the quantity of urine he passes and by the frequent calls to void it, or he notices that while his appetite is greatly increased he is growing weaker and thinner. The urine is not only greatly increased in quantity, but somewhat changed in appearance; it is paler, transparent when first passed, and assumes on standing an opalescent tint like the whey of milk or a solution of honey in water. It has no odor, or a somewhat aromatic one, compared by some to that of new-made hay, by Dr. Watson to that of a room in which apples have been kept. If kept for a few days at a moderately elevated temperature, instead of acquiring an ammoniacal odor, like ordinary urine, it has a sharp, vinous smell, and will be found to be acid rather than alkaline. The urine has commonly a decidedly sweet taste; drops of it upon the patient's linen or clothes stiffen them like starch, and sometimes leave on evaporation a powdery efflorescence. The specific gravity of the urine is greatly augmented; instead of being on the average about 1.024, as is commonly the case, it ranges from 1.025 to 1.050; M. Bouchardat reports it even as high as 1.074. Two or three simple tests are sufficient to render the presence of sugar certain. In Trommer's test, a drop or two of solution of sulphate of copper is added to a little of the urine in a test tube; a solution of caustic potash is now added in excess, and the mixture gently boiled over a spirit lamp for a few minutes; if sugar is present, a precipitate of a reddish or yellowish brown color (suboxide of copper) will be thrown down, otherwise the precipitate will be black (common oxide). In Moore's test, a little of the urine is mixed in a test tube with about half its volume of liquor potassæ, and the mixture boiled five minutes; if sugar be present, the fluid will acquire a brown hue, otherwise it remains unchanged. A third test is founded on the fact that diabetic urine rapidly undergoes fermentation when mixed with a little yeast and kept in a warm place. The sugar to which diabetic urine owes its peculiar properties exists in the form of glucose or grape sugar. This is present in all proportions, from a mere trace to 30, 50, and even 134 parts in 1,000. The quantity of solid matter thus drained from the system is very great; Watson estimates it on the average at 1½ lb. a day, but it sometimes amounts to many times this quantity; and it is this drain of solid matter, together with the large amount of urine passed, which gives rise



to the constant thirst and enormous appetite. Early in the disease the symptoms are not well marked; when the complaint is established, and the large excretion of urine begins to attract attention, the patient complains that despite his excessive appetite he grows thinner and weaker; the mouth is pasty, the skin dry and hard, the bowels constipated. The digestive functions, at first normal, become deranged; the patient is troubled with heartburn, with a feeling of weight and pain in the epigastrium, and sometimes with vomiting. The strength declines, he becomes emaciated, the generative functions are impaired or lost; vision often becomes dim, the gums are spongy, there is tenderness and swelling about the orifice of the urethra, the memory and intellect fail, and the temper becomes irritable. In the course of the disease pulmonary consumption is very apt to supervene and carry off the patient. Toward the last diarrhœa, fetid breath, effusion into the great cavities, and œdema of the extremities precede death. Diabetes is essentially a chronic disease, lasting often many years; it is also obstinate and intractable, although most of the cases seem benefited by treatment, and sometimes it appears to be completely cured.—In the beginning of the present century Dr. Rollo found that the amount of urine in diabetic patients as well as its sweetness was very much diminished by confining them to an animal diet. When the ready conversion of starch into grape sugar became known, this was assumed to be the origin of the sugar, and the benefit derived from an exclusively animal diet was thus explained. But few patients have the resolution to restrict themselves for any length of time to such a diet, and even when persevered in it is found to be merely palliative. C. Bernard has ascertained that sugar is a normal production of the liver in all classes of animals, carnivorous as well as herbivorous; that it takes place in the liver of the fœtus as well as in that of the adult; that irritating the origin of the pneumogastric nerves in the fourth ventricle increases the secretion of sugar, producing an artificial diabetes. In a state of health the normal secretion of sugar poured into the circulation by the hepatic veins is rapidly decomposed and excreted by the lungs; when the amount is increased by disease, the excess passes off by the kidneys. Under the influence of diastase, sugar is likewise formed from the starch of the food in the process of digestion, as a necessary preliminary to its absorption. When diabetic patients are placed upon an animal diet, this source of supply is cut off, and the amount of sugar in the urine is diminished, but it is still present, since the liver keeps up a supply. M. Mialhe, believing that sugar in the course of the circulation is decomposed under the influence of the alkalinity of the blood, and that in diabetes the blood is deficient in alkalinity either positively or relatively to the amount of sugar contained in it, recommends the use of bicarbon-

ate of soda in large doses. He recommends half a drachm to be taken three times a day, morning, noon, and night; this is gradually increased until from 180 to 270 grains are taken in the course of the day. In addition, the patient is directed to take Vichy water with his meals, and is recommended to drink two or three pints of lime water daily. He is allowed the ordinary variety in his diet, but the quantity of farinaceous food is reduced one half, or at least one third. Flannel is ordered to be worn next the skin; the vapor bath is administered two or three times a week. By these means Mialhe reports a number of cases to have been cured. Dr. A. Clark (New York "Medical and Surgical Journal," January, 1859) reports several cases of diabetes either cured or greatly benefited by the use of bicarbonate of soda and of blisters to the nape of the neck. He administered the soda in doses of 11 grains, to be taken as frequently as could be borne until the urine was rendered alkaline or the stomach was nauseated. Besides the alkaline treatment, the means principally relied on have been, restricting the quantity of farinaceous matter in the patient's diet as far as possible, indulging him in watery vegetables (spinach, turnips, cabbage, &c.) rather than in bread or potatoes, and the use of opium. This last remedy allays the nervous irritability of the patient, and diminishes the thirst and the urinary secretion.—*Diabetes insipidus* is a disease characterized like the above by the daily discharge of an unnatural quantity of urine; but in this case it is of less specific gravity than natural, and contains no sugar. It consists in fact of the discharge of an excessive quantity of water by the kidneys, the natural ingredients of the urine being simply diluted by the increased volume of the fluid. The daily quantity of urine discharged in this disease may amount to several gallons, while its specific gravity is as low as 1.005. It is accompanied by a corresponding thirst, the patient drinking water enough to supply that discharged by the kidneys. Diabetes insipidus often lasts a long time without serious injury to the health.

**DIAGORAS OF MELOS**, surnamed the Atheist, a Greek philosopher, lived in the time of Socrates and Aristophanes, but neither the date of his birth nor that of his death is known. He must have removed from his native island to Athens before the performance of the "Clouds" of Aristophanes (423 B. C.), for he is alluded to in that piece as one well known to the Athenians. He was a disciple of Democritus of Abdera. He ridiculed the popular religion, and attacked especially the Eleusinian mysteries. He was accused of impiety (411), but the real grievance was his politics. Fearing the result of a trial, he made his escape from the city. He was condemned to death by the court, and a price set upon his head; yet he lived for a time at Pallene, and finally died at peace in Corinth. His works are all lost.

**DIAL**, an instrument for ascertaining the hour of the day by means of rays of light coming from the heavenly bodies. There are therefore solar, lunar, and astral dials. The sun dial only will be considered in this article. It is one of the oldest of human inventions, but its origin cannot be traced. The earliest historical mention of it is in the Old Testament, where we are told of the miracle wrought with the dial of Ahaz, king of Judah, at the instance of the prophet Isaiah, for a sign to Hezekiah, the son of Ahaz. The instrument used by the Chaldean historian and astronomer Berossus, early in the 3d century B. C., is the most ancient of whose form we have any precise account. It was a hollow hemisphere, with its convexity turned toward the earth, and a button or small globe held in the spherical centre, which, by casting a shadow in the concavity, marked the succeeding hours from one rim to the opposite. It gave place to dials which required more mathematical knowledge for their construction; but a hemisphere properly adjusted will answer the purpose of a dial very well, and was used by several nations long after the commencement of our era. Four have been discovered in modern times in Italy. One found at Tivoli in 1746 is supposed to have belonged to Cicero. Another was found in 1762 at Pompeii, and as it was adapted to the latitude of Memphis, it has been ascribed to the Egyptians, although no sun dial has ever been discovered among the ruins of Egypt, nor have any representations of it been found among their sculptures. It is believed, however, that they used some form of sun dial, notwithstanding the care they bestowed upon clepsydras, and their probable use of the pendulum. Perhaps the obelisks erected in honor of the sun were used as gnomons, and it has been suggested that the famous circle of Osymandyas might have been used to determine the azimuths of the heavenly bodies, and therefore the hours of the day. The tower of the winds at Athens, which from its architecture is judged to be of a somewhat later date than the time of Pericles, is an octagonal structure, and bears eight sun dials for the cardinal and intermediate points of the compass. They are described in Stuart's "Antiquities of Athens." Four others, known as the dials of Phædrus, also found at Athens, are now in the British museum, and are described in Delambre's *Histoire de l'Astronomie ancienne*. Their construction shows that the Greeks used geometrical methods for vertical and also for declining dials. The first sun dial said to have been erected in Rome was by L. Papius Cursor, who had taken it from the Samnites. About 30 years after another was placed near it by M. Valerius Messala, who brought it from Sicily in the second year of the first Punic war. It was made for the latitude of Catania,  $41\frac{1}{2}^\circ$  south of Rome. The first dial constructed at Rome, and adapted to its latitude, is said to have been by the order of Q. Marcius Philip-

pius, in 164 B. C.—The sun dial may have many forms, depending upon its position in regard to the sun, and upon the latitude in which it is used. The most common form at the present day is the horizontal dial. It consists of a horizontal plate upon which the hours are marked, and which supports a style or gnomon for casting the sun's shadow, having its edge parallel with the axis of the earth. Another form is that called the equinoctial dial, consisting of a staff or gnomon placed parallel with the axis of the earth, and passing perpendicularly through the centre of a circle divided into equal parts for marking the hours. The slight deviation of the sun's apparent from the true time is not taken into account in the construction of dials, the correction being made after the observation is taken. Let fig. 1 rep-

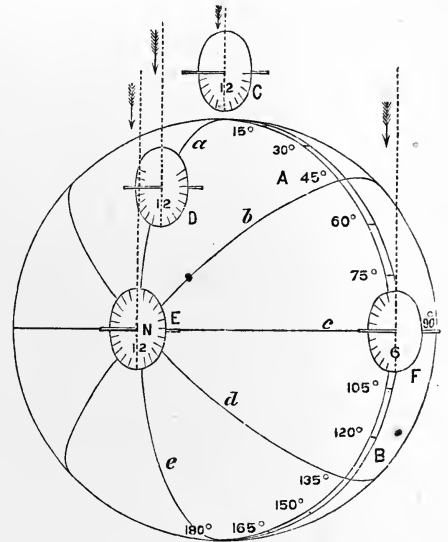

Fig. 1.

resent the earth, N the north pole, A B the equator, and *a, b, c, d, e*, meridian lines; *a, c*, and *e* marking the quadrants. As the earth revolves on its axis with uniform motion once in 24 hours, each point moves through  $15^\circ$  every hour; therefore, if it is noon on the meridian *a*, in three hours after it will be noon on the meridian *b*,  $45^\circ$  from *a*, and in six hours the meridian *c*, marked  $90^\circ$ , will be brought vertically beneath the sun. All the rays of the sun which strike the earth are apparently parallel, because of his immense distance, which is about 12,000 times the earth's diameter. It will therefore be 6 o'clock in the morning on the meridian *c* when it is noon on the meridian *a*. Suppose a circle to be placed at the pole, in the plane of the horizon, and divided into degrees corresponding with those on the equator, and a staff which shall represent an extension of the earth's axis to pass through its centre; it follows that when the sun's path is



faces, for the reason that the shadow of the sun can never fall upon the south face before 6 in the morning or after 6 in the evening; but when he rises before 6 in the morning his beams will fall upon the north face. This, being the counterpart of the south face, will show the hour. A horizontal dial and the south face of a vertical one are represented in fig. 3. Neither of these forms can be used with much accuracy in less than  $20^\circ$  of latitude, because as we approach the equator the gnomon becomes more and more parallel with the horizon, so that if its length remains the same the upper end will cast but a very small shadow during the hours near midday. For instance, during the first hour before or after noon the sun in passing through  $15^\circ$  will cast a shadow on the horizontal plane but little more than one fourth the height of the gnomon. If this be 6 in., the edge of the shadow will be only  $1\frac{1}{2}$  in. from the perpendicular. As the height of the upper end of the gnomon above the dial is to its length as the sine of an angle is to the radius, it follows that in lat.  $30^\circ$  the edge of the gnomon would require to be 12 in. in order to give it an elevation of 6 in. To retain this elevation in lat.  $10^\circ$ , the gnomon would have to be about  $3\frac{1}{2}$  ft. long, and in lat.  $5^\circ$  about 7 ft.; which, for various reasons (one of which is that the oblique shadows would be too dim to be plainly discernible), makes its use impracticable. The nearer we approach the pole the more does the gnomon approach a perpendicular position, until at the pole it becomes an extension of the earth's axis; the hour angles, as marked upon the horizontal plane, becoming equal, as shown at E in fig. 1.

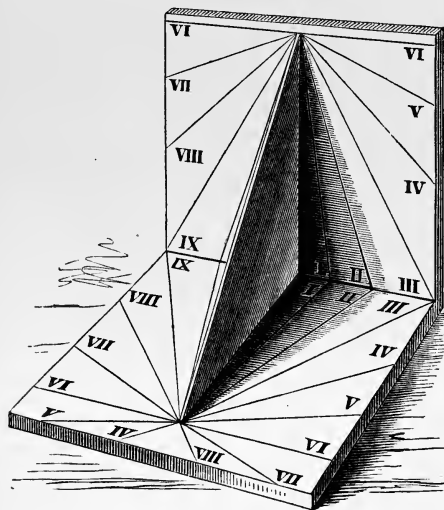

Fig. 3.

—A glass cylinder having a rod for an axis and its surface marked with 24 equidistant lines, parallel with the axis, was used by Ferguson in the construction of dials, and is itself a form

of equinoctial dial which may be used in any latitude by placing its axis parallel with the axis of the earth. It would thus be a modification of the dial of Berosus, if the hour lines

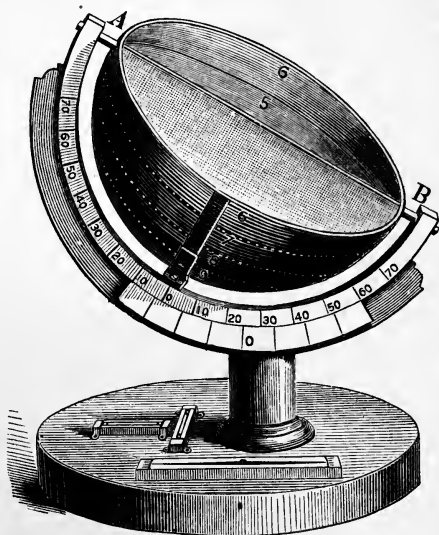

Fig. 4.

were marked upon the latter as meridians, the shadow of the axis falling upon the parallel lines of the cylinder precisely as they would upon the meridians of the hemispheres. Fig. 4 represents the hemisphere of Berosus suspended in a graduated arc, by means of which its gnomon may be adjusted to the latitude of the place. It may also be turned upon its axis and held at any degree of inclination to the east or west, so that when the days are more than 12 hours long it will indicate the time before 6 in the morning and after 6 in the evening. The lines 5, 6, 7, 8, &c., are intended to represent meridians, and should meet at the poles A B. A magnetic needle and a pair of spirit levels facilitate its adjustment. Burt's solar compass (see COMPASS, SOLAR) contains a sun dial which is an elaboration of this plan. An hour arc is held in a plane having an inclination corresponding to the latitude of the place. Over this arc an arm, attached to what is called the declination arc, is made to move until the sun's rays coincide with the axis of the arm, when the number of degrees traversed by the hour arc will indicate the sun's apparent time. This is the most correct sun dial that can be constructed.

**DIALYSIS** (Gr. *διάλυσις*, a separating), or **Analysis by Diffusion**, names given by Prof. Thomas Graham to a method proposed by him for effecting certain separations, usually of compound substances one from another, by means of the different rates at which substances diffuse through moist gelatine-like films or other septa, or upward through water or viscid

masses. (See ENDOSMOSE, and GAS, vol. vii., p. 634.) An example will illustrate the nature of the processes and results. A sheet of thin paper being thoroughly moistened, and depressed at the middle to form a sort of cup, a solution containing 5 per cent. each of cane sugar and gum arabic is poured into it; and the paper cup is then placed upon the surface of water in a deep basin narrow enough to keep its edges elevated, and left for 24 hours. The cup being removed at the end of the time, the quantity of liquid it contains is found increased by endosmose; but while a little of the liquid in the vessel below, tested with acetate of lead, shows a mere trace of gum, upon evaporation of the remainder the sugar crystallizes from it, in quantity equal to three fourths of that placed within the paper cup. The sugar, therefore, has rapidly made its way through the septum used, while the passage of the gum has been almost perfectly resisted. The paper can be replaced by moist animal membrane, or by a thin layer or film of any substance having the character of a jelly, as hydrated gelatine, albumen, mucus, or gelatinous starch; but the most useful septum is parchment paper in thin sheets and without sensible flaw or porosity. It is found that, through moist films or partitions such as those here named, through masses of different substances in the gelatinous state, or through liquids, very many and perhaps all substances capable of crystallization in definite forms make their way by diffusion at rates which, though differing for the different substances, are rapid in comparison with those at which any substance having itself the gelatinous or jelly-like condition can traverse or diffuse in the same media. These facts led Prof. Graham to divide the great body of chemical substances (especially compounds) into two classes, which are readily characterized by the tendency of the former to crystallize definitely, either alone or in combination with water, and to dissolve rapidly and generally in solutions free from viscosity; while the latter when dry incline to the vitreous structure, having little tendency to crystallize, dissolve slowly or only soften, and as a rule assume the viscid or gelatinous state. To these classes, respectively, he gives the names of "crystalloids" and "colloids" (the latter from the Gr. *κόλλη*, glue). In experiments such as those already referred to, the paper sized with starch, or other film or membrane containing a jelly or viscid material of any sort, is a colloidal partition or body; and the colloid gum has very slight power to penetrate it. This is found true also of such substances as hydrated silicic acid, a number of hydrated metallic peroxides, starch, vegetable gums, dextrine, caramel, tannin, albumen, and vegetable and animal extractive matters, all of which are colloids. The crystalloids, however, as cane sugar, and a large number of chlorides, sulphates; &c., of metallic bases, readily penetrate the colloidal

partitions or media; and the explanation given is, not that either class of substance is afforded or denied passage through any effect of capillary attraction as ordinarily understood, but that, the affinity of any colloid for water being of the feeblest character, one colloid cannot with any rapidity abstract molecule for molecule the water from another, by which process it could be conveyed through it; while the crystalloids brought in contact with a moist colloid, having a high affinity for water, can displace the colloid from solution particle by particle, and thus make their way through its mass. These results are beautifully shown by placing at the bottom of two glass jars respectively, in a little starch jelly and then surmounted with several inches depth of the same jelly, a colored crystalloid, as bichromate of potash, and a colored colloid, as caramel; the gradual elevation of the former through the mass can be daily observed, while at the end of eight days the caramel has scarcely begun to discolor the jelly above its first position. The different rates of diffusion through such septa allow of the employment of the method thus discovered for separating, in degree or partially, one from among two or more crystalloids existing in mixture, but more readily and satisfactorily a crystalloid from a colloid. To this peculiar mode of separation Graham gives the name dialysis. It is conveniently effected with a "hoop dialyser," a sheet of parchment paper stretched beneath a hoop, and secured about it in the manner of a sieve. The sheet being moistened, and receiving in it a very thin layer of the solution from which some substance is to be separated (the separation being more rapid as the layer is thinner), is floated on a sufficient body of water in a larger vessel. To separate in degree two or more crystalloids, the simpler method of "jar diffusion" often suffices. The mixed solution of crystalloids is conveyed by use of a pipette, so quietly as to leave the superincumbent liquid quite undisturbed, to the bottom of a jar of water or alcohol, and left at rest; the most diffusible substance rises most rapidly, and is more entirely separated from the others as the time is greater, and the height to which it ascends through the column increases. By carefully drawing off with a siphon, at the end of the experiment, successive strata of the liquid into separate vessels, and quantitatively analyzing their contents, the quantities of the "diffusates" in the strata from below upward, and so the diffusibilities of the substances, are determined. Thus, with 10 per cent. solutions in pure water, introduced to the bottom of separate vessels, beneath 4.38 in. of pure water, 1 per cent. of common salt in solution had at the end of 14 days reached the uppermost of 16 strata of equal depth in the column; while in the same time sugar had barely appeared (.005 gramme) in the uppermost stratum, gum had diffused itself to the tenth stratum, and tannin to the ninth, from the bottom. By such means, with

proper care and noting of conditions, the absolute and comparative diffusibilities of substances can be determined. Hydrochloric acid and the allied hydracids are found to be the most diffusible substances known; the solid chlorides are high in the scale, and of these apparently chloride of sodium highest. As an illustration of the results of series of experiments, the approximate times of equal diffusion of the following substances were found as here given: hydrochloric acid, 1; chloride of sodium, 2.33; sugar, and sulphate of magnesia, 7; albumen, 49; caramel, 98. When two or more diffusible substances are mixed, the difference in their rates of diffusion is increased, and effective analysis by diffusion is thus favored. The rate of diffusion is much accelerated by elevation of temperature of the liquid or mass, so that separations may be effected in less time at high temperatures; but the degree of separation is less, since at the same time the less diffusible substances gain in the higher ratio. The rate of diffusion of all substances is less in alcohol, and probably in most other liquids, than in water, or in semi-fluid masses rendered such by water. The name "diffusate" has been given to any substance as diffused, or separated by dialysis.—The relations and applications of the new facts, and the principle which is their basis, are numerous, and some of them of high importance. The dialyser affords an advantageous method for completely purifying soluble colloids without risk of decomposition, by the readiness with which all crystalloid substances pass from them into water; and Prof. Graham in his paper ("Philosophical Transactions," 1861, part i., p. 183) gives directions for the preparation and purification of many substances of this class. Besides the distinctions already referred to, it will be observed that crystalloid bodies tend to aggregate in plane films and with angular outlines, and are hard and solid; while the more usual condition of the colloid is that showing rounded outlines, a homogeneous mass, with more or less softness and toughness of texture. The water of crystallization in the former is represented by water of gelatination in the latter. The colloids are usually insipid; the crystalloids more commonly have a marked taste. Chemically, the former are the inert bodies; the latter, usually active, or energetic. But as observed in their most usual conditions, the rigid crystalloids are almost wholly unsusceptible to external impressions; while the soft colloids have a wide sensibility to external agencies, and thus great mutability of condition. Even the simply mineral colloids cannot long be kept without change—pure hydrated silicic acid, or soluble silica, sealed up tightly, undergoing change within a few days or weeks; and the existence of many of them is only in and during a continued metamorphosis. This is especially true of albumen, gelatine, mucus, and related substances, as existing in the fluids and living

tissues of the animal body. These colloids are plastic or nutritive, and apparently in good part because they are mutable or capable of those successive metamorphoses during which the conditions of vitality can be secured, and in turn vital force and action evolved and manifested. Thus, these elements stand physiologically in relations the reverse of those they show chemically; and Prof. Graham accordingly terms the crystalloid a statical, and the colloid a dynamical condition of matter. He suggests that the colloidal condition of matter may be looked upon as "the probable primary source of the force appearing in the phenomena of vitality;" while "to the gradual manner in which colloidal changes take place (for they always demand time as an element) may the characteristic protraction of chemicorganic changes also be referred;" in these intending to include, of course, the time required for application of the power of the will, for exertion of muscular force, and the physical changes that underlie the phenomena of sensation and thought. The facts observed in connection with diffusion appear to lead to a new understanding of endosmosis, as effected, in part at least, by the circumstances that a colloid cannot abstract water from (or dehydrate) another colloid or a crystalloid, while a crystalloid can readily dehydrate a colloid, and in so doing effect its own movement through the latter.—The method of dialysis can be employed for the extraction of arsenic, tartar emetic, corrosive sublimate, strychnine, morphine, and other crystalline poisons in the stomach, blood, milk, or any organic mixture. The crystalloid poisons will pass through the septum into the outer vessel, where their presence can be shown by the usual tests. By it soluble albumen may be obtained in a state of purity, by addition of acetic acid, and use of a colloidal septum. Nitrate of silver, from photographer's waste, when put into the dialyser readily separates from the albumen and other organic impurities, and can thus be saved. As early as 1864 Mr. Whitelaw took out a patent in England for the removal of chloride of sodium and nitre from the brine of corned and salted meats by means of dialysis. Liebig has shown that the brine contains a large proportion of the nutritious constituents of the meat; and if we could remove the salts and evaporate the residue, we should have all of the properties of a good soup. This process is successfully accomplished by Mr. Whitelaw's apparatus, as the savory and valuable constituents of the meat are colloids, and will not therefore pass through a membrane. A further technical application of the doctrine of dialysis is in the extraction of sugar from the beet; and it has been proposed to apply the same method to the extraction of sugar from the cane. The contrivances employed by sugar refiners are called osmogenes, and they are now much used in Germany and France. Graham applied the principle of dialysis to the concentration of the

oxygen of the air. When air is passed through shavings of India rubber, the rubber retains a portion of the nitrogen, and the proportion of oxygen can be increased to 41 per cent. The proposition has also been made to separate substances which fuse at different temperatures by passing them through porous walls made of refractory material. This is called dialysis in the dry way.

**DIAMAGNETISM** (Gr. *διά*, through, and *μαγνήτης*, magnetic). In the native magnet (an ore of iron) resides a peculiar force, which, if a mass of this body be suspended freely, turns or directs it into a line nearly parallel with a meridian on the earth's surface, the same end of the magnet being always directed toward the north. Certain bodies, especially iron, brought near to a magnet, have the magnetic condition induced in them, the extremity nearer either magnetic pole becoming a pole of the opposite name, that more remote a pole of the same name. Small magnetizable particles, as iron filings, dusted upon a surface on which a magnet rests, or agitated near it, become arranged in lines which, between unlike poles that are presented to each other, run across in straight lines, while about those on either side they form curves, making larger and larger sweeps into space. The lines thus indicated have been named magnetic curves, or lines of force. Until recently the number of magnetic bodies was supposed to be very small. Becquerel in 1827 found that a needle of wood playing freely on a pivot took a direction across, not in, the magnetic curves; and in 1829 Le Bailly also observed that bismuth repelled the magnetic needle. But the significance of these facts was not understood until Faraday in 1845, in the course of his experiments on magnetic rotary polarization, observed that a bar of so-called "heavy glass," suspended between the poles of an electro-magnet, moved, as soon as by the passage of the electrical current magnetism was induced in the latter, into a position crossing the lines of force, or at right angles to the line joining the poles. Terming the position assumed by a soft iron bar, which is lengthwise between the two poles, or from one to the other, axial, Faraday gave to the new direction assumed by the glass the name of equatorial. The glass was not merely thus directed, it was repelled by either pole; and if, reduced to the form of a small mass or cube, it was thrown out of the lines joining the poles to one side or the other, it moved into the position of weakest magnetic action. He also sealed up various liquids in long tubes of thin glass, and suspended them between the poles; some arranged themselves axially, others equatorially. This new-found property of certain bodies Faraday termed diamagnetism; and in contrast with this he denominated the familiar form of magnetic action paramagnetism. His experiments warrant the conclusion that, with a sufficiently powerful electro-magnet, all substances whatever can be shown to

exhibit one or other of these properties. (See **MAGNETISM**.)

**DIAMANTINA**, a city of Brazil, in the province of Minas Geraes, capital of the ancient district of Tijuco, which was also formerly the name of the city, 270 m. N. of Rio de Janeiro; lat. 18° 28' S., lon. 43° 50' W.; pop. about 7,000. The city is built in amphitheatre on a steep acclivity, 5,648 feet above sea level. The streets are irregular, and the pavement indifferent; a few of the houses are fine, and the whitewashed walls of the others contrast prettily with the brilliant green foliage and golden fruit of the rows of orange and banana trees which surround almost every dwelling. Of the numerous churches some are handsome, especially the negro church dedicated to Nossa Senhora do Rozario, remarkable for a statue of a black Virgin surmounting the altar. Save in the public edifices, which are of stone, the building materials are mostly either mud or wood. There are three hospitals, barracks, a primary school, and a good market. Flowers, vegetables, and European fruits are cultivated in the gardens, of which one is attached to each house; and excellent water is supplied from crystalline springs. The inhabitants are mainly occupied in washing for gold and diamonds, both of which abound in the surrounding country. (See **DIAMOND DISTRICT**.)

**DIAMOND** (a contraction of adamant, from Gr. *α* privative, *δαμῆν*, to subdue), a gem so named on account of its extreme hardness, for which, and its brilliancy and beautiful play of prismatic colors, it excels all others. The diamond is pure crystallized carbon, and has a specific gravity slightly varying, according to the different qualities, as follows: Brazilian, colorless, 3.444; Brazilian, yellow, 3.519; oriental, colorless, 3.521; oriental, green, 3.524; oriental, blue, 3.525. Its hardness, according to an artificial standard scale, is 10, greater than that of any other known substance, that of corundum being 9, and that of quartz 7. The primitive form of the crystal, and that into which the secondary forms may be converted by cleavage, is the regular octahedron. The faces of the crystals are often convex, and the edges curved. The cleavage planes greatly facilitate its cutting, and also present the most brilliant natural surfaces. The gem is not acted upon by acids or alkalis, and when air is excluded may be heated to whiteness without injury. When exposed to the heat of a powerful galvanic battery, it fuses and is converted into a mass resembling coke, its specific gravity being sometimes reduced to 2.68. Its combustion may be effected in the open air or in oxygen gas, but it requires a very intense heat, which is scarcely estimable from the difficulty of using apparatus. Its combustibility was first proved by the Florentine academicians in 1694, by subjecting it to the solar rays concentrated in the focus of the large parabolic reflector made for Cosmo de' Medici, when it burned with a blue, lambent flame.—The diamond is found in alluvial de-

posits which are worked for gold, sometimes attached to loose pieces of brown hematite, and sometimes in a conglomerate of quartz and chalcedony, cemented by ferruginous clay; but it is not certain in what geological formation it originated. Generally in regions where the diamond is found there also occurs a laminated granular quartz rock, called itacolumite, of talcose formation, and which in thin plates is more or less flexible. According to M. Denis, it is found in Minas Geraes, Brazil, in two different deposits: one, called *gargulho*, which is composed of pieces of broken quartz, covered by a thin bed of earth; and the other, called *cascalho*, composed of quartz pebbles, united by ferruginous clay, and usually resting on talcose clays, the whole being débris from talcose rocks. The first is said to yield the finest diamonds, and both contain gold, platinum, and magnetic iron. The diamond mines of India have the same character as those of Brazil, the alluvial earth being a conglomerate of more or less tenacity, which requires to be broken up. The diamond was long known in Asia, in Hindostan, Borneo, Sumatra, and in the Ural mountains, before it was discovered elsewhere; the district from Cape Comorin to the bay of Bengal, including the famous mines of Golconda, furnishing the world until 1728, when the Brazilian mines were discovered. (See DIAMOND DISTRICT.) The South African diamond fields were discovered through some children finding a diamond of  $21\frac{1}{4}$  carats on the banks of the Orange river, in 1868. In 1869 the "Star of South Africa," of  $83\frac{1}{4}$  carats, was found by a Griqua shepherd; and on the borders of the Vaal river several small stones were found early in 1870. Since then the search has increased, until now there are said to be more than 4,000 persons, over an extent of nearly 1,500 sq. m., chiefly in the valleys of the Orange and Vaal rivers and at their junction, between lat.  $26^{\circ}$  and  $28^{\circ}$  S., and lon.  $24^{\circ}$  and  $26^{\circ}$  E. The diamonds are found, from the surface to a depth of 70 ft., in an alluvial calcareous earth, with rolled pebbles of quartz, chalcedony, jasper, and garnets, and decomposed feldspathic and micaceous rocks, resting on carbonaceous shale. The peculiarity of the African diamond is the great number of stones of 80 carats and upward, with a preponderance of 90 per cent. of yellow-tinted. The commercial effect of such a quantity of yellow diamonds coming at once on the market has been to depreciate their value in an extraordinary degree, large yellow stones being now but one fourth the price they were five years since; small stones are not quite one half their previous value. The whole of the South African diamond region, about 17,000 sq. m., was annexed in 1871 as a colony of Great Britain, under the title of Griqualand. Recently the Brazilian fields have ceased to be profitable, and many of the mines are abandoned, few retaining the full number of workmen; and even

the South African fields are said to be declining. In the United States, diamonds have been discovered in Rutherford co., N. C., and in Hall co., Ga.; also at Paris mine, Franklin co., N. C.; and at the village of Manchester, opposite Richmond, Va.; in California, at Cherokee ravine, in Butte co.; at Forest hill, El Dorado co., one of  $1\frac{1}{2}$  carat, and at French Corral one of  $1\frac{1}{4}$  carat, have been found. In Australia, they have been met with in the valley of the Turon, in the bed of the Macquarie river, at Victoria, and at Fremantle in Western Australia.—Diamonds are found of various colors, as well as colorless and perfectly transparent. The latter are most esteemed, and are distinguished as diamonds of the first water from their semblance to a drop of clear spring water. When of a rose tint and of clear water, they are also highly valued. A yellow shade is objectionable, as is a cinnamon color, a stone having these rarely being clear and sound. Next to the rose, a green color is the least objectionable; many very fine diamonds have this tint; and some are found of a bluish color, and some black. For the valuation of diamonds an arbitrary rule has been given, which is, however, little regarded in actual sales of the most costly of these gems. Purchasers for such being few, the only real rule adopted, as in the sale of many other commodities, is to demand the highest price there is the least probability that one may be induced to pay. The mere statement of the rule is sufficient to show its indefiniteness. It is to multiply the square of the weight in carats by a sum varying according to the state and quality of the stone. If clear and of good shape, this sum was £2; if perfect and well cut, £6 or £8 for the brilliant or rose, but a lower figure for the table. The rate is now \$50 in place of the £2 above, and a specimen brilliant is worth \$200. For diamonds of moderate size the rates vary as little as those of exchange between countries. They follow from the natural proportions in which diamonds are found. Diamonds weighing over 10 carats have a higher proportional theoretical value than the smaller sizes; yet the latter can commonly be sold at higher proportional rates, on account of the few purchasers for those of large size. In the great sale of jewels in London in 1837, on the distribution of the Deccan booty obtained by the army of the marquis of Hastings, the splendid Nassuck diamond, weighing  $357\frac{1}{2}$  grains, and of the purest water, brought only £7,200. In December, 1858, £33,000 was paid for a stone weighing 61 carats, and £15,000 for a pair of drop-shaped diamonds for earrings. The finest gems of commerce are now in great part supplied by the old jewels of Portuguese, Spanish, French, and English families, the proportions from each nation being in the order named; and the best market for them is now the United States.—The origin of the art of cutting diamonds in a scientific manner is ascribed to Louis Berquen in 1456, who established a



guild of diamond cutters at Bruges about the year 1470. Three large rough stones were intrusted to him by Charles the Bold, duke of Burgundy, for the cutting of which he received 3,000 ducats. Diamond cutting was for a long time a monopoly in Holland, and the business is at the present day mostly confined to Amsterdam. The process, which consists of grinding down the surfaces as well as cutting, is slow and tedious, and being done by hand, occupies for a single stone the continual labor of months. The Pitt diamond required two years for the completion of the process. Two diamonds are employed, each cemented into the end of a stick or handle. The stones are then rubbed together with a strong pressure, being held over a metal box having a double bottom, the upper one perforated with small holes, through which diamond dust falls. This is afterward carefully collected, mixed with vegetable oil, and used for polishing the gem upon a revolving cast-iron disk. When a large piece is to be removed from the stone, it is sometimes cut off by means of a steel wire covered with diamond powder, and sometimes by the use of a chisel and hammer, though in this way there is danger of destroying the stone. The workmen should understand perfectly the position of the cleavage planes, as it is only upon them that pieces can be removed by the chisel. The forms usually adopted in cutting the diamond are the brilliant, the rose, and the table. The first shows the gem to the best advantage. It is composed of a principal face called the table, surrounded by a number of facets which are cut upon that part of the stone which shows above the setting, and which is called the bezil. The greatest circumference forms the girdle, and below this is the pavilion, which should have a depth equal to one half the diameter of the gem at the girdle. The pavilion is terminated by a small facet, called the culet, which may be either square or octagonal. As the brilliant is the most economical of material, and shows the stone most advantageously, it is usually preferred to any other. The rose, which is very brilliant, is flat below and cut into facets entirely over the upper surface. The table is least beautiful, and is used mostly in India for thin stones with a large surface, which are ornamented by being cut into facets at the edges.—Among the most celebrated diamonds known, that obtained by Mr. Pitt, governor of Madras, is perhaps one of the finest and most perfect. It is known as the regent. Its weight before cutting was 410 carats, and by this process, which occupied two years, it was reduced to 136 carats, and was purchased by the regent duke of Orleans in 1718 for \$675,000. Its present value is estimated at \$1,000,000. It was placed by Napoleon in the hilt of the sword of state, and was captured by the Prussians at Waterloo. A splendid diamond found in Brazil some years ago, and carried to France, is called the "Star of the South." It weighs in its rough state 254½ carats. Its general form

is a rhomboidal dodecahedron, and upon its faces are impressions which appear to have been made by other diamonds, so that the whole was probably a group of diamond crystals. The famous diamond in possession of the king of Portugal is also from Brazil. If genuine, of which there is some doubt, its value, according to the rule of computation, should be \$28,000,000, weighing as it does in the rough 1,680 grains. The famous Koh-i-noor or "Mountain of Light" is now in possession of the queen of England. This stone, interesting alike for its historical associations and for its intrinsic beauty, was, according to Indian tradition, obtained before the Christian era from one of the mines of Golconda. From the rajah of Oojein, who seems to have possessed it at the beginning of the Christian era, it passed to successive sovereigns of central India, and in the early part of the 14th century was added to the treasures of Delhi by the Patan monarch Aladdin. It remained in possession of the ruling families of the empire until the irruption of the Persian conqueror Nadir Shah, who saw it glittering in the turban of the vanquished Mohammed Shah, and proposing an exchange of head dress as a mark of friendship, bore it away with him, and gave it the name by which it is still known. After the assassination of Nadir it passed through the hands of Ahmed Shah of Cabool to Shah Shujah, who paid it as the price of his liberty to his conqueror Runjeet Singh, the "lion of the Punjab," in 1813. On the annexation of the Punjab to the East India company's territory in 1849, it was stipulated that the Koh-i-noor should be surrendered to the queen of England, to whom it was accordingly delivered by the company, July 3, 1850. At this period its weight was 186 carats. It was exhibited at the crystal palace in London in 1851, where it attracted universal attention; but its display of colors was inferior to that of its glass model, and it was necessary to surround it with a number of vivid lights to develop its colored refractions. An examination was made by scientific gentlemen, among them Sir David Brewster, with reference to the propriety of recutting the gem. After obtaining the opinions of skillful cutters at Amsterdam, it was decided that the attempt should be made, and it was given in charge of Mr. Coster of that city, who afterward cut the Star of the South. The diamond so long in possession of the sultan of Matan, of the island of Borneo, is remarkable for its size and purity. It weighs 367 carats, and should be worth at least \$3,500,000. It is shaped like an egg with an indented hollow in the smaller end. It was discovered at Landak. The Orloff diamond, purchased for the empress Catharine II. of Russia, is about the size of a pigeon's egg, and weighs 195 carats. It is said to have formed the eye of a famous idol in a temple of Brahma at Pondicherry. A French deserter robbed the pagoda of this valuable stone. After passing through the hands of various purchasers, it came into the possession

of a Greek merchant, who received for it from the empress \$450,000, an annuity of \$20,000, and a title of nobility. The Austrian diamond is of a beautiful lemon color, and cut in rose; its weight is 139 carats. Its value is less than it would be but for its color and the form in which it is cut, ranking as worth \$500,000 instead of \$750,000. The most valuable diamond found in the United States was picked up by a workman at Manchester, on the banks of the James river, opposite Richmond, in 1856. The locality is in the tertiary formation, and the diamond originally belonged, no doubt, to the gold region up the river. It is of curvilinear octahedral form, specific gravity 3.503, and weighs 23.7 carats. It is lightly chatoyant, and would probably cut white; but an original flaw was increased by the rough treatment it received from those into whose hands it fell, so that its value was greatly deteriorated.—The process of collecting diamonds is similar to that of collecting gold in the alluvial deposits. The coarse gravel and rolled pebbles derived from the primary and metamorphic rocks form the lowest stratum among the sands and clays of the alluvium. This stratum, resting upon the surface of the rock, is the repository alike of gold and of diamonds. It is laid bare in the beds of the streams, when these cease to flow in the dry season, or are drawn off by sluices made for the purpose. From these beds, as well as from excavations in the bottom, the gravelly conglomerate or *cascalho* is removed, to be washed when convenient. This in Brazil is usually in the rainy season, and the work is done in a long shed, through which a stream of water is conveyed, and admitted into boxes in which the *cascalho* is washed. A negro works at each box, and inspectors are placed to watch the work, and to prevent the laborers from secreting the diamonds. It is the custom to liberate the negro who finds a diamond weighing  $17\frac{1}{2}$  carats. Dr. Beke, in a paper read at a meeting of the British association, relates that a slave in Brazil seeking for diamonds in the bed of a river broke with his iron bar through a crust of silicious materials, cemented together by oxide of iron, in which he discovered a bed of diamonds, which were afterward sold for \$1,500,000. This immense quantity, being carried to England, so overstocked the market that few of the English houses were able to stand up against it.—Besides their use as ornaments, diamonds are applied to several practical purposes. An impure diamond, but very hard, and colored black, known under the name of *bort*, is used for arming the bits of the diamond drill (see BORING), and is also crushed to fine powder in a steel mortar, and used for coating the metallic disks employed by lapidaries for producing flat surfaces on precious stones of great hardness. The fine splinters are made into drills, for piercing small holes through rubies and other hard stones. The property possessed by the diamond of cutting glass is due not merely

to its extreme hardness, but to the peculiarity of its crystallization in rounded faces and curvilinear edges. The natural crystal only is suitable for this purpose.—The diamond exhibiting the physical properties of matter in their highest state of perfection, and proving after all to be of the simplest chemical composition, it has been a matter of no little scientific interest to study the peculiarities of its construction, and to determine if possible the secret processes by which nature has elaborated the most perfect gem from so homely a substance as charcoal. Its high value has stimulated these researches, in the hope of individual profit by its artificial production. But though more complicated forms of matter have been successfully reproduced, carbon has not yet been made to attain the simple perfection of the diamond, unless it be in crystals invisible to the naked eye; nor have we yet learned from what department of nature's works the material has been taken, that has been so beautifully perfected. The vegetable kingdom may have furnished it, after itself receiving it from the atmosphere, or it may have been unlocked from those repositories of carbon shut up from remote geological periods in the carbonic acid of the calcareous rocks, or from such collections of fossilized plants as are now seen in various stages of change to mineral substance. But if the direct object of these researches has not been attained, the forces which have acted upon it to give to it some of its peculiarities have been partially determined, as also a previous condition in which it must have existed. Sir David Brewster, from the exhibition of polarized light around the minute and irregular cavities in diamonds, has concluded that the substance has once been in a soft state, and compressed in these parts by the expansive action of a gas or fluid contained in the cavities; and as various circumstances indicate that this softness was not the effect of either solvents or heat, he is of opinion that, like amber, the diamond is a vegetable substance, slowly consolidated into a crystalline form. The nearest approach to its reproduction has been in the experiments of M. Despretz. By long continued voltaic action, carbon free from every trace of mineral substance, prepared from crystallized sugar candy, was made to deposit microscopic crystals in black octahedrons, in colorless translucent plates, the whole of which had the hardness of the powder of the diamond, and which disappeared in combustion without leaving any perceptible residue. Being, however, only in powder, it was impossible to isolate and weigh these crystals, or to determine their index of refraction and angles of polarization. It is said that a similar result has been obtained by decomposing a mixture of chloride of carbon and alcohol by galvanic currents continued for six months.—The principal English works on the subject are D. Jeffrey's "Treatise on Diamonds and Pearls" (8vo, London, 1750); J. Mawe's "Treatise on Dia-

monds and Precious Stones" (8vo, London, 1826); and "Diamonds and Precious Stones" by Harry Emanuel (12mo, London, 1867; New York, 1873).

**DIAMOND DISTRICT** (Port. *Distrito Diamantino*), a district in Brazil, so called from the diamond grounds for which it has long been celebrated, situated in the Serra do Frio, in the province of Minas Geraes. It extends from E. to W. between lat. 17° and 19° S., and is watered by the Jequitinhonha and several tributary streams of the Rio São Francisco. In 1725 Sebastião Leme do Prado discovered the Manso, a small affluent of the Jequitinhonha, and found some white stones which were sent as specimens to the court of Portugal, where, however, they at first attracted little attention. After an interval of three or four years, Bernardo da Fonseca Lobo penetrated into the hitherto unexplored serras, and discovered similar stones, one among which was of extraordinary size; but as no one knew the value of the gems, they were frequently used as counters at play. A certain *ouvidor* of the province, who had been in India, perceiving that they were diamonds, purchased a large number at a merely nominal price, and returned to Portugal, about the same time when Almeida, first governor of Minas Geraes, informed the court of the real nature of the stones. Adventurers hastened to profit by the discovery; but discord soon sprang up among them, and quarrels ensued which often ended in bloodshed. By letters patent, issued in February, 1730, the diamonds were declared crown property; but the liberty to continue the search for gems was purchasable at the rate of 20 milreis (\$10) for each negro engaged for the purpose. This impost was soon after increased to 40, and finally to 50 milreis. The crown profited little by these contracts; and in 1771 the government placed the management of the mining under the surveillance of officers specially appointed for the charge, employing at the same time 5,000 negroes at the works. A decree was issued prohibiting the search for gold within the limits of the diamond region, all the approaches to which were guarded by soldiers; while stringent laws were passed to provide for the registering of the inhabitants, the admission of settlers, the erection of inns and shops, and the punishment of infringements of the government monopoly. In pursuance of a law passed in 1873, the diamond mines now belong exclusively to private individuals. A singular uniformity has been observed respecting the diamond grounds of this district. The same cubic mass will yield in washing pretty nearly the same number of carats, whether of large or small diamonds. Though very large gems do not abound in Brazil, some of considerable dimensions have at times been found.—For the product of these diamond mines, see BRAZIL, vol. iii., p. 221; and for the mode of working them, see DIAMOND.

**DIANA**, an ancient Italian divinity, corresponding in most of her attributes with the Greek Artemis. Artemis was the daughter of Zeus and Leto or Latona, and the twin sister of Apollo, and the island of Delos is generally assigned as her birthplace. She represented as a female divinity the same idea that Apollo did as a male divinity, and like her brother sent plague and death among men and animals; but as Apollo was also the alleviator as well as the author of suffering, so she too was a preserving goddess, watching over the sick and aiding the unfortunate. As sister of the sun god, she was goddess of the moon; hence her identification in later times with Selene or Luna, and her Latin names Lucina and Phœbe. Unlike Apollo, she had nothing to do with music or poetry. She was the guardian of young girls and of women in childbirth, but was herself a virgin, and the ministers of her worship were vowed to chastity. As the goddess of the moon she wore a long robe and veil, with the crescent moon above her forehead. In Arcadia she was the patron of hunting and of sylvan sports, and as such she was represented with a bow, quiver, and arrows. She loved to dwell in groves and in the vicinity of wells, and to dance with her nymphs in the forest; and nearly all her surnames and epithets are derived from mountains, rivers, or lakes, indicating that she was the representative of some power of nature. In Tauris she was worshipped with human sacrifices, and in Sparta boys were scourged at her altar till it was sprinkled with their blood, a ceremony said to have been introduced by Lyeurgus as a substitute for immolation. The Ephesian Artemis was the personification of the fructifying powers of nature, and was represented in her magnificent temple at Ephesus as a goddess with many breasts. The worship of the Roman Diana is said to have been introduced by the Sabines and Latins. A temple was erected to her on the Aventine by Servius Tullius, and the day of its dedication was celebrated every year by slaves of both sexes, and was called the day of the slaves. From this it is inferred that Diana was an inferior deity in Rome in the early days, and that her worship was not recognized by the ruling patricians; but whatever was her original character, she afterward became identified with the Greek divinity.

**DIANA OF POITIERS**, duchess of Valentinois, mistress of Henry II. of France, born Sept. 3, 1499, died at Anet, in Orléanais, April 22, 1566. At the age of 13 she became the wife of Louis de Brézé, count de Maulevrier, and grand seneschal of Normandy, by whom she had two daughters. She was attached to the court of Queen Claude, and when her father, the seigneur de St. Vallier, had been condemned to death for favoring the escape of the constable de Bourbon, she so touched the heart of Francis I. by her tears and beauty, that the punishment was commuted. In 1531

her husband died, and Diana, putting on widow's weeds, expressed a resolve to wear them till her death; but this did not prevent her when nearly 40 years old from becoming the mistress of the dauphin (her junior by nearly 20 years), afterward Henry II. The duchess d'Étampes then possessed the affections of Francis I., and the two favorites divided the court until the accession of the dauphin in 1547, when Diana became almost mistress of the kingdom, and her rival was sent into exile. The beauty and accomplishments of the young queen, Catharine de' Medici, could not prevail against her influence. The king delighted in giving public tokens of his infatuation, admitted her to his councils, and in 1548 created her duchess of Valentinois. She retained her ascendancy until Henry's death in 1559, when she retired to the palace built for her by her royal lover at Anet; but in 1561 she was recalled by Catharine de' Medici to exert her influence in detaching the constable de Montmorency from the Châtillons. From that time until her death she remained in retirement. Her power over the king, even when she had reached the age of 60, was due no less to her beauty than to her intellect. She spent large sums in charity.

**DIAPHORETICS** (Gr. *διαφορεω*, to carry through), medicines or agents which promote perspiration. (See PERSPIRATION.) The skin is one of the channels for the discharge of saline substances, and therefore these, particularly the salts of the alkalies, are promoters of the sudoriferous action of the skin. To facilitate their action, the skin should be kept warm and the body in a recumbent position. Bathing with tepid water, as tending to produce exosmosis through the glandular membrane, is also favorable. Among the most important diaphoretic saline medicines are tartar emetic, or the double tartrate of antimony and potash, the carbonates of soda, potash, and ammonia, and sulphate of potash, which is one of the constituents of Dover's powder. The tartar emetic is one of the most powerful, and may be used to assist the action of other diaphoretics by producing relaxation, and narcotics may be used for the same purpose. Among vegetable diaphoretics may be mentioned ipecacuanha, another constituent of Dover's powder, guaiacum, and camphor. It must not be forgotten that water, forming as it does nearly the whole of the perspiration, is perhaps the most powerful as well as safest of all diaphoretics, aided as it may be by warmth, exercise, and friction, and that it should nearly always form an important adjunct to the administration of medicinal diaphoretics.

**DIAPHRAGM**, the transverse muscle which separates the thoracic from the abdominal cavity in mammalian vertebrates. It is flattened, nearly circular, fleshy at the edges, tendinous in the centre, elongated, and ends in a point behind. In front it is attached to the ensiform cartilage of the breast bone, on the

sides to the internal surface of the last six ribs, behind to the transverse process of the first lumbar vertebra and to the bodies of the first three vertebrae of the loins by tendinous slips; the fleshy fibres of the last form the pillars of the diaphragm, and their fasciculi cross each other in such a way as to leave two openings, one superior and anterior, giving passage to the œsophagus and par vagum nerve, the other inferior, for the passage of the aorta, thoracic duct, and vena azygos; the tendinous centre has been compared in shape to a leaf of clover. Between the middle and right portion of the tendinous centre is the opening for the passage of the inferior vena cava. The diaphragm is in relation, above, with the pericardium in the middle, and with the pleuræ, base of the lungs, and walls of the chest on the sides; below, with the aorta in the middle, the kidneys, renal capsules, pancreas, and duodenum; on the right side with the liver, and on the left with the stomach and spleen. The direction of the posterior fibres is nearly vertical; all the others converge toward the tendinous centre. The diaphragm is the great muscle of respiration; when it contracts, its central ten-

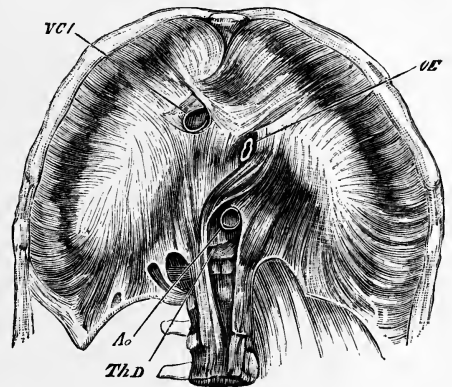

The Diaphragm viewed from the Lower or Abdominal Side. *V. C. I.*, the vena cava inferior; *œ*, the œsophagus; *A.*, the aorta; *Th. D.*, the thoracic duct, cut where they pass through the diaphragm, the broad white tendinous middle of which is easily distinguished from the radiating muscular fibres which pass down to the ribs and into the pillars in front of the vertebrae.

dinous portion is drawn downward, the cavity of the chest is enlarged, and air rushes in to expand the lungs during the act of inspiration; when forcibly contracted, it may act as an assistant to the abdominal expiratory muscles by diminishing the size of the base of the chest; by its action on the abdominal viscera it aids in the expulsion of fæces and urine; in ordinarily tranquil breathing the diaphragm is sufficient for the performance of the function. In animals the extent and position of the diaphragm vary according to the number of the ribs; in those whose ribs extend nearly to the pelvis, as in the horse, the thoracic convexity of the diaphragm is much greater than in man.

This important muscle is liable to malformations, wounds, and morbid conditions; its total absence is incompatible with any other than intra-uterine life, as aerial respiration would be impossible; its partial absence, like dilatation of its natural openings, or laceration of its fibres, is accompanied by the passage of more or less of the abdominal viscera into the chest, impeding the action of the heart, lungs, and digestive organs; in such cases, the liver, stomach, omentum, ileum, cæcum, and part of the colon, have been found above the diaphragm. This partition is also liable to penetrating wounds, and to rupture from external violence, the latter being the most dangerous; in either case, nature alone can remedy the evil. It is sometimes inflamed, and in the rheumatic diathesis is the seat of the most acute pain, increased by every respiratory act, and forcing the patient to breathe almost entirely by means of the abdominal muscles. Spasmodic contractions are familiarly known by the phenomenon of hiccough; this is sometimes merely a nervous affection, and at others is a symptom of peritonitis, strangulated hernia, and other abdominal diseases.

**DIARBEKIR**, or *Diarbekir*, also called *Diarbek-Amid*, and *Kara-Amid* (anc. *Amida*), a town of Turkey in Asia, capital of a vilayet of the same name (Turkish Kurdistan), on a rocky eminence a short distance from the right bank of the Tigris, in lat. 37° 55' 30" N., lon. 39° 52' E., 155 m. S. S. W. of Erzerum. A fertile and well cultivated plain surrounds the city, which is encompassed by walls pierced by four gates, and surmounted by many towers. In the N. E. portion are the ruins of the citadel, formerly the residence of the pasha. It was once a very flourishing place, and contained, it is said, 400,000 inhabitants in 1750; but owing to the predatory disposition of the Kurds, who have rendered unsafe the intercourse with Bagdad and Aleppo, its prosperity has declined, and it now contains only about 35,000, chiefly Mohammedans and Armenians. It is the seat of an Armenian archbishop and three Catholic bishops (united Armenian, Chaldean, and united Syrian). Some trade is carried on with Aleppo, and the manufacture of cotton and silk goods, though much diminished, is still continued. The streets are narrow and dirty, and most of the houses are of rough stone covered with a plaster of mud and straw. It contains many mosques, an Armenian cathedral and other Christian churches, numerous baths, caravansaries, and bazaars, and is well supplied with water, which is introduced by a fine aqueduct, and distributed through the city in numerous stone fountains. The walls are built of a dark-colored basalt, quarried in the neighborhood, and many of the principal buildings are of the same material.—*Diarbekir*, then called *Amida*, was enlarged and fortified by Constantine. On the invasion of Mesopotamia by the Saracens it fell into their hands. At the end of the 14th

century it was pillaged by the Mongols under Tamerlane, and in 1515 it was captured by Sultan Selim I.

**DIARRHŒA** (Gr. *διάρρῆν*, to flow through), a disease characterized by frequent loose alvine discharges. In a proper system of nosology diarrhœa would scarce find a place; it is a symptom rather than a disease, and is produced by a number of different pathological conditions. It is present in the course of typhoid fever, is a frequent accompaniment of phthisis, and is sometimes an attendant upon albuminuria and other forms of blood poisoning; it is caused by inflammation and ulceration of the bowels. Those slighter forms of the complaint only will be noticed here which are independent of constitutional causes, and which are produced by a temporary irritation or sub-inflammation of the intestinal mucous membrane. Diarrhœa is often caused by the use of crude and indigestible food, or even by food ordinarily wholesome taken in too great quantity or variety. Fruit, particularly when acid and unripe, uncooked vegetables, as cucumbers and salads, food in a state of incipient decomposition, the flesh of immature animals, as young veal, &c., are all liable to act upon the bowels. Certain articles, as mushrooms, shellfish, the richer varieties of ordinary fish, as salmon, from peculiarity of habit disagree with particular individuals and produce diarrhœa. The same is true of a total change of diet; food perfectly wholesome to those accustomed to it, and the water used habitually in certain districts of country, often cause bowel complaints in the stranger. Emotions of the mind, particularly grief and anger, in some persons promptly occasion an attack of diarrhœa; others are affected in the same way by sudden changes of temperature, wet feet, or exposure to cold. Where diarrhœa is caused by the ingestion of food rendered irritating by its quantity or quality, the purging itself soon removes the cause of irritation and the diarrhœa ceases; if this should not be the case, a moderate opiate or an anodyne combined with an astringent are all that is necessary. When diarrhœa is dependent on exposure to cold, a bland, unirritating diet, the warm bath, and the use of opium or of opium and ipecacuanha in small doses, may be had recourse to; in such cases the patient is generally benefited by wearing a flannel bandage around the abdomen.—Infants at the breast sometimes suffer from bowel complaint; here it is commonly caused by over-feeding. Ordinarily nature provides against this by the facility with which the infant vomits; the stomach frees itself from the excess of food, and no mischief is done; but when the infant does not vomit, diarrhœa is caused, and undigested curd is present in large quantity in the evacuations. The obvious remedy is the prolongation of the intervals at which the child is suckled. During dentition in infants, from the large quantity of blood sent to the digestive organs, and the rapid evolution which they are

undergoing, the bowels are irritable, and diarrhoea often supervenes; this is best guarded against by care in the diet and a proper observance of hygienic regulations.—A popular remedy for diarrhoea, especially in cases which precede an attack of cholera, is a mixture of equal parts of laudanum, tincture of rhubarb, spirits of camphor, tincture of capsicum, and essence of peppermint, taken in doses of 20 to 30 drops in a little water at frequent intervals until relief is afforded. (See CHOLERA.)

**DIAS, A. Gonçalves**, a Brazilian poet, born in Caxias, Aug. 10, 1823, died at sea in 1864. He was educated in Portugal, and returning to his native country published a volume of poems entitled *Primeiros cantos* (Rio de Janeiro, 1846), which was followed by his drama of *Leonor de Mendonça*, *Segundos cantos*, and *Ultimos cantos*. In 1848 he was chosen professor of national history in the college of Dom Pedro II. In 1855 he was sent by the government to study the scientific institutions of France and Germany. Returning to Brazil in 1858, he was appointed historian and ethnographer to the expedition sent by the government to explore the provinces bordering on the Amazon. In consequence of his arduous labors in this expedition he visited Europe in 1862 to restore his health. In September, 1864, he embarked for Brazil, and died near the coast. Dias published the first four cantos of an American epic, *Os Tymbiras* (Leipsic, 1857), and a *Diccionario da lingua Tupy, chamada lingua brasileira* (Leipsic, 1858). A collection of his poems, under the title *Cantos*, was published at Leipsic (4th ed., 1865). His poetry is popular in Brazil.

**DIAS, Bartholomeu**, a Portuguese navigator, born about the middle of the 15th century, lost at sea, May 29, 1500, while on his way from Brazil to India. In 1486 he sailed on an expedition to explore the W. coast of Africa, and without knowing it was carried around the southern point of the continent and landed at the mouth of Great Fish river, where he discovered that he was on the E. coast. The stormy cape, which he doubled on his return in 1487, he called *Cabo Tormentoso*, a name which the king of Portugal changed into *Cabo de Boa Esperança* or Cape of Good Hope. He subsequently sailed on another African expedition under Vasco da Gama; and he commanded one of the vessels in the fleet with which Cabral discovered Brazil. It was on this expedition that he perished.

**DIASTASE** (Gr. *διασσειν*, to separate), a peculiar principle which is formed during the germination of seeds. It is most abundantly produced in the cereals, particularly in barley. It is formed at the base of the sprout, by a change which takes place in the albumen within and about the germ by the action of the vitalizing principle which has been awakened within it by heat and moisture. For the mode of producing diastase, see BREWING. It may be extracted from malt by steeping in water at

about 80° F., when it will be dissolved together with an albuminous body. A pasty mixture is produced, which is pressed, and the liquor filtered and heated to about 170°, to coagulate the albuminous body, and again filtered. This filtrate contains the diastase, and may be used for obtaining the peculiar effects of that body; but to obtain it in a pure state it is precipitated from the solution by the action of absolute alcohol. It is a white, amorphous, flocculent substance, soluble in water and dilute alcohol, but insoluble in absolute alcohol, tasteless, and easily decomposed. Moistened starch, when subjected to the action of only a minute quantity of it (one part in 2,000, according to Payen and Persoz), at 150° F., soon becomes disorganized and converted into soluble starch, dextrine, and grape sugar. Diastase in solution changes so readily that it soon becomes acid and loses its power of transforming starch. It is destroyed by boiling its solution; an important fact, which is taken advantage of in the manufacture of dextrine, to arrest the transformation when the production of that substance has reached the greatest practicable amount, and also in the brewing of beer, for the purpose of preventing fermentation during the cooling of the wort. It has never been obtained in such a condition as to afford a satisfactory analysis. According to the above authorities, the amount of nitrogen varies, being less when the substance has been carefully prepared. From this fact, and from the convertibility of starch into glucose by several other substances, it has been suggested that instead of being a principle of definite composition, it is probably an albuminous compound, passing through a change or series of changes. This view is strengthened by the discovery, by Dubrunfaut, of another substance in malt, similar in its effects, which he has called maltine, and finds to be even more active than diastase; an equal quantity being capable of effecting ten times as much transformation. He also obtained a third but less active substance than diastase, and believes the latter and the other two substances to be the same body undergoing decomposition. The action of alcohol when used to precipitate the diastase destroys the so-called modifications.

**DIATHERMANCY** (Gr. *διά*, through, and *θερμα*, heat), permeability to the rays of heat. Diathermanous bodies have the same relation to calorific rays that transparent ones have to rays of light; and those bodies which are impermeable to rays of heat, or bear the same relation to it that opaque ones do to light, are called athermanous. It was long known that rays of heat from an intense source were capable of passing through certain transparent substances, like glass, in lines subject to the same laws of refraction as those of light; but it was not supposed that such transmission was possible through bodies which are opaque to light. Pictet of Geneva was the first to show that radiant heat, from obscure as well as from

luminous sources, would pass through plates of different transparent substances. But it was even then believed by many that the heat was communicated by being absorbed and subse-

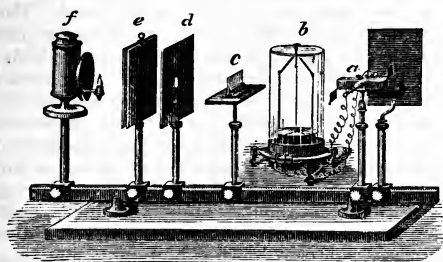

Melloni's Apparatus.

quently radiated by the transmitting body, until Prévost of Geneva proved the fallacy of this idea by passing rays of heat through ice, of sufficient power to ignite combustible substances. The investigations of Melloni, however, placed the subject in a clearer light, and to him we owe much of the facts that other distinguished investigators (among whom are Bunsen, Kirchhoff, Tyndall, and Balfour Stewart) have elucidated by numerous brilliant experiments, which have given the subjects of radiant heat and light so much interest at the present time. The apparatus used by Melloni in his experiments on the diathermancy of various bodies is represented in the engraving. Nobili's thermo-electric pile, made of alternate layers of bismuth and antimony, represented at *a*, connected by copper wires with a delicate galvanometer *b*, constituted the thermometer employed by Melloni to measure the radiant heat transmitted through the substances experimented upon, and which he termed his thermo-multiplier. The transmitted rays were received upon one of the faces of the pile, and generated galvanic electricity in proportion to their quantity, which was indicated by the galvanometer. The body whose diathermancy was the subject of experiment was placed upon an adjustable stand at *c*, while two screens, *d* and *e*, one for excluding the rays of heat until the test should commence, and the other for limiting the pencil of rays, were placed between *c* and the source of heat, *f*, which might be a Locatelli lamp, a coil of incandescent platinum wire, a heated metallic ball, a can of boiling water, or any other body heated to the desired degree. During his investigations he made an important discovery, which has since been used to great practical advantage by Tyndall in many brilliant experiments upon the transmission of heat through gases and vapors, viz.: that rock salt is almost perfectly diathermanous to radiant heat from all sources, whether luminous or obscure. Indeed, he supposed it to be perfectly diathermanous, attributing the nearly constant loss of 7.7 per cent. of the heat falling upon it to reflection from the surface. In testing the diathermancy of liquids, Melloni

placed them in narrow troughs of thin glass, and measured their transmitting capacity by the difference in the amount of heat which passed through them when empty and when filled with the liquid. The following table shows the percentage of heat transmitted by several of the substances with which Melloni experimented, using four different sources of heat. The experiments were made by ascertaining the deflection of the needle of the thermo-multiplier when the rays from each source were passed through air, and, calling this amount 100, passing the rays from each source through the various substances, and noticing the deflection produced.

DIATHERMANCY OF SOLIDS.

SUBSTANCES, ¾ of an inch thick.	Locatelli Lamp.	Incan- descent platinum.	Copper at 752° F.	Copper at 212° F.
Rock salt.....	92.3	92.3	92.3	92.3
Sicilian sulphur.....	74	77	60	54
Fluor spar.....	72	69	42	38
Beryl.....	54	23	13	0
Iceland spar.....	39	23	6	0
Glass.....	39	24	6	0
Rock crystal, clear.....	38	23	6	3
Smoky quartz.....	37	23	6	3
Chromate of potash.....	34	28	15	0
Carbonate of lead.....	32	23	4	0
Sulphate of baryta.....	24	18	3	0
Feldspar.....	23	19	6	0
Borate of soda.....	13	12	8	0
Selenite.....	14	5	0	0
Tartrate of potash.....	11	3	0	0
Alum.....	9	2	0	0
Sugar candy.....	8	1	0	0
Ice.....	6	0.5	0	0

These results show that transparency to rays of light and permeability to those of heat, or diathermancy, although they accompany each other to a certain extent, do not do so proportionately. Rock salt, it is seen, is equally diathermanous to all the sources named in the table. It is found, however, to be not perfectly diathermanous to rays of extremely low refrangibility, as will be noticed further on. The difference exhibited by glass in transmitting heat from the different sources is very marked. Thus, while transmitting 39 per cent. of the rays from a Locatelli lamp, and 28 from incandescent platinum, it permits the passage of only 6 per cent. of those which are emitted from copper heated to 752° F., and is completely opaque to those issuing from copper at 212°. Again, clear rock crystal transmitted only 1 per cent. more heat from the Locatelli lamp than did smoky quartz, and no more from the other sources; a fact which shows how little heat is contained in the highly luminous rays of the spectrum. The low diathermancy of ice is here also shown; a property which adapts it, as well as the other forms of water, which share it in a like degree, to the various relations it sustains with organized life. The following table, also from Melloni, shows the amount of transmission by various liquids, the source of heat being an argand lamp with a glass chimney, and the liquids ¾ of an inch in thickness, held in glass cells:

## DIATHERMANCY OF LIQUIDS.

LIQUIDS, $\frac{1}{8}$ of an inch thick.	Percentage of transmission.
Bisulphide of carbon.....	63
Bichloride of sulphur.....	63
Protochloride of phosphorus.....	62
Oil of turpentine.....	31
Olive oil.....	30
Naphtha.....	25
Oil of lavender.....	26
Sulphuric ether.....	21
Alcohol.....	15
Acetic acid.....	12
Concentrated solution of sugar.....	12
Distilled water.....	11

A remarkable fact in relation to the diathermancy of bodies is that rays of heat which have once been transmitted by a substance will readily pass through a second plate of the same material with little or no loss; that is, glass is nearly diathermanous to heat which has already passed through glass, and ice is nearly diathermanous to heat which has passed through water or ice, or a considerable depth of watery vapor. Another very important fact, intimately connected with the subject of molecular physics, is that all bodies, solids, liquids, and gases, are nearly athermanous to heat which is radiated by the same body. Thus, rock salt, which is nearly diathermanous to all sources of heat, absorbs most of the rays that are radiated by heated rock salt. Balfour Stewart found that a moderately thick plate of cold rock salt would stop three fourths of the heat radiated from a plate of rock salt. This fact is accounted for on the wave theory, by supposing that the rays of very low refrangibility, which are the ones radiated by this substance, have the power of exciting vibrations of the same wave length in the same material, and are therefore accepted or absorbed; whereas the rays of higher refrangibility, and consequently of shorter wave length, which most other bodies emit, are allowed to pass through rock salt because they have not the power, by reason of non-accordance, to set its particles into vibration. From the fact that this substance only radiates heat of low refrangibility, it would be concluded that when heated it would require a long time to cool, and also that it would accept radiant heat slowly, although it is readily warmed by conduction; and this conclusion is borne out by experiment. The absorbing and radiating powers of bodies are reciprocal and equal, as has been shown by the experiments of Sir John Leslie, Ritchie, and others. The diathermancy of a body may therefore be stated as inversely proportional to its power of radiation. Athermanous bodies, or those which are only slightly diathermanous, are more permeable to rays of high than to those of low refrangibility; consequently, if the luminousness of a flame is increased, although it may contain no more heat, it will radiate more through partially diathermanous media, as for instance moist air, glass, and alum. Again,

if its luminousness is decreased, these media will be more opaque to its rays; and if heat of still lower refrangibility is substituted for the flame, their opacity will be the more increased. The investigations of Tyndall on the heat-absorbing powers of various liquids and gases, or in other words their relative diathermancy, have also thrown much light on the subject of the molecular constitution of matter. He has shown that elementary bodies are generally much more diathermanous than compounds. This has been used as a remarkable evidence in favor of the wave theory of light, because by adopting it the phenomena of transmission and absorption are perfectly accounted for, and in no other way. Placing a solution of iodine in bisulphide of carbon in a rock salt prism, he found that it transmitted 99 per cent. of all the rays emitted by a body heated below luminousness. Converging the rays which were transmitted through the solution, he found them as effectual in producing combustion as if the transmission had not been made. Iodine is therefore diathermanous to rays of obscure heat. The elementary gases and their mechanical mixtures he found to be almost perfectly diathermanous, while compound gases and vapors are partially so, many of them transmitting only rays of high refrangibility, or those belonging to the luminous spectrum. The diathermancy of dry atmospheric air was found to be more than 250 times that of nitrous oxide gas, a chemical compound of the constituents of the air in the same proportion; and this he regards as one of the strongest proofs that the atmosphere is a mechanical mixture, and not a chemical compound. In experimenting upon the conductivity of different substances, Tyndall found that this property in a body was generally commensurate with its diathermancy, with one exception, which was that slightly diathermanous rock crystal was a better conductor than almost perfectly diathermanous rock salt. The latter substance has, however, a high conducting power; and it was found that rock salt, glass, calcareous spar, selenite, and alum maintained the same order of conductivity that they did of diathermancy in the experiments of Melloni. Some of the experiments made by Tyndall will be more particularly described in the article on HEAT. The object he had in view made it necessary to employ apparatus which would allow of the transmission of the rays of lowest refrangibility, because it is these that are especially interfered with by vapors and compound gases. His sources of heat were often metal surfaces heated with boiling water, or to a temperature far below redness, and the rays were passed through a tube whose ends were closed with plates of transparent rock salt. This tube could be exhausted before the gas or vapor was admitted, and the latter could be introduced through apparatus which excluded all moisture; so that many errors which have often affected the value of



previous experiments were avoided. The following table shows the relative absorption of radiant heat of several different elementary and compound gases, and the vast difference in the degree of diathermancy which they possess; the transmission was made through each of the gases at the common pressure of the atmosphere:

DIATHERMANCY OF GASES.

GASES.	Relative absorption.
Air.....	1
Oxygen.....	1
Nitrogen.....	1
Hydrogen.....	1
Chlorine.....	39
Hydrochloric acid.....	62
Carbonic oxide.....	90
Carbonic acid.....	90
Nitrous oxide.....	355
Sulphuretted hydrogen.....	390
Marsh gas.....	403
Sulphurous acid.....	710
Olefant gas.....	970
Ammonia.....	1195

Although these gases are perfectly permeable to all the rays of the luminous spectrum, to those of the obscure heat which was employed in these experiments they exhibit a great difference of absorbing power, nitrous oxide gas absorbing 355 times and ammonia 1,195 times as much as dry air. If the tube had been closed with partially athermanous glass instead of diathermanous rock salt, no such results could have been obtained, as the glass would have sifted out nearly all the rays of low refrangibility before they fell upon the gases whose powers of absorption were the subject of experiment.—The investigations which have been made upon the subject of diathermancy have been of great advantage in arriving at theoretical conclusions in regard to the molecular constitution of matter. In undertaking to explain why radiant heat of low refrangibility passes so much more readily through elementary than through compound gases, the mind is obliged to form conceptions of the different conditions in which the atoms are arranged in these two classes of matter. In the elementary gas they must be so disposed as to allow the waves of heat to vibrate freely without accepting their vibrations, while in the compound gas they must be so arranged as to receive or unite with them, or, in common language, to absorb them. In one case, therefore, the mind conceives of the atoms as swinging in the ether singly, receiving but little motion from its vibrations; while in the other they are grouped together in compound masses or molecules, which offer more obstruction to the ethereal waves, and therefore transfer to themselves a corresponding degree of energy. Tyndall found the body ozone to be highly athermanous, a quality which greatly distinguishes it from common oxygen. It has been held that ozone is a compound of oxygen and hydrogen. Now, heat destroys ozone, leaving oxygen; but if it also

contains hydrogen, some aqueous vapor must also result from the disorganization of the ozone. This vapor remaining in the oxygen would impair its diathermancy. But the gas obtained by heating ozone is as diathermanous as oxygen obtained in the ordinary way; therefore it contains no aqueous vapor, and the ozone from which it was derived must be simply oxygen, with its atoms grouped together somewhat after the manner of a compound gas. The diathermancy of iodine to the obscure, and its opacity to the luminous rays, allows the visible to be divided from the invisible spectrum which lies beyond the red rays, by passing the light of an incandescent body through a hollow prism of rock salt containing a solution of iodine in bisulphide of carbon. The conclusion to be arrived at from a consideration of this fact is, in the opinion of Tyndall, that the luminous waves which are intercepted by the iodine are in accord with its dissolved atoms, and therefore can transfer their motion or energy to them. Transparency and diathermancy he therefore considers as synonymous with discord, and opacity and athermancy as synonymous with accord, between the waves of ether and those of the molecules of the body on which they fall, or through which they pass. The blackness of lamplack he ascribes to the accord between the vibrations of its atoms and the waves embraced within the luminous portion of the spectrum; and the luminous rays which it absorbs are the ones which it radiates when raised to a sufficient temperature. But lamplack is also diathermanous to the very extreme obscure rays of the spectrum; a fact which was shown by Melloni. Aqueous vapor, although perfectly transparent to the luminous rays of the spectrum, was found by Tyndall to be quite opaque to those of the dark spectrum. This is one of the most interesting facts connected with the whole subject of heat, and of the greatest importance, not only in a strictly scientific sense, but in its practical bearing upon questions of meteorology, and therefore upon the business of every-day life. The formation of clouds by the radiation and consequent loss of heat from vapor through the drier atmosphere above, as well as by the condensation produced by currents of cool air, and the formation of dew from the same cause, the equalness of moist climates and the cold of high mountains, could never have been well understood unless the subject of the comparative diathermancy of dry and moist gases, particularly of the atmosphere in its various hygrometric conditions, had been carefully investigated.

**DIATOMACEÆ**, minute plants growing in moist situations, in collections of fresh water or in the sea, consisting of frustules of various forms, the walls of which contain a large quantity of silex, and are often beautifully diversified and marbled by striae or by dots. Notwithstanding the general resemblance of these curious vegetations to the species of desmidiæ, they

are clearly made distinct by the flinty fronds, singular striation, and absence of green coloring matter. Agardh asserts that many of these organisms have as much affinity with the mineral kingdom as with the vegetable, being in fact vegetable crystals, bounded by right lines and collected into a crystalliform body, and having no other difference from minerals than that the individuals have the power of again separating from each other. As in the case of the desmidiæ, there are solitary species, and others grouped so as to form lines and membranes. In some, the production of new plants from spores presents the same dissimilarity between the young and the adult forms. There are also numerous genera which can be accurately distinguished not only by the difference of form or outline, but by their own peculiar striations, markings, and dots. In both the single and the associated species there is a distinct pellucid peduncle or footstalk. This is sometimes considerably dilated above, or else forked, sometimes repeatedly. In this case each frustule remains attached, the base dilating as may be required. This arrangement gives a fan-like appearance of great beauty.

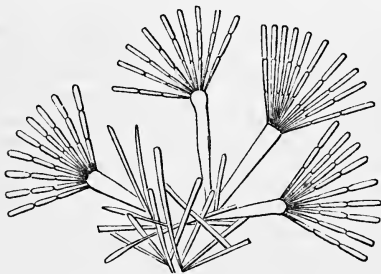

*Echinella flabellata*, a fan-like marine diatom.

But in the thread-like species it is only the corners that remain attached; as no stem or footstalk is visible here, it has been conjectured that it exists only in those plants which have grown from spores or in the seedling forms. Certain channels or apertures are so arranged as to convey the water to the inner cellular membranes, and thus to afford nutriment. The same curious conjugation to be seen in other algæ has been detected in the diatomaceæ by Thwaites, and has been confirmed by Berkeley and Broome. It is computed that vast areas of solid earthy matter are due to the growth, presence, and decay of these minute organisms. Many of the most beautiful are found in the guano of commerce, doubtless swallowed in the food of birds, and still remaining in perfect preservation. In the United States, masses of several inches in thickness are found on the bottoms of ponds, composed of myriads of these organisms, which on being exposed to desiccation become as white and friable as chalk. Even peat bogs and meadows abound with them. The polishing powders sold under the name of tripoli are composed of these natural silicious frag-

ments. The soundings on the shores of Victoria Barrier, Australia, in water whose average depth is 1,800 ft., were found by Dr. Hooker to be invariably charged with diatomaceous remains. These fossil species are often so identical with recent ones, that it would be scarcely too extravagant to admit the assertion of Ehrenberg, that species are to be found in a living state in situations where they have been propagated from times far anterior to the existence of man. The United States are rich in the diatomaceæ, both fossil and living. In the tertiary infusorial stratum of Richmond, Va., Ehrenberg detected 20 genera and 46 species, of which all were also European excepting two. This group of American forms is of peculiar interest, because the strata at Richmond are decidedly of marine origin, and consequently give at once a general view of these marine microscopic forms along the North American coast. Of the perfectly free diatoms we have many species of *naviculaceæ* remarkable for beauty, symmetry, or delicacy, or else for their striations. The largest, most common, and most easily distinguished is *navicula viridis*, of an oblong outline, found in every ditch and pond. It can be detected in great abundance in the ashes of peat, and in the deposits of infusorial earths. Its length is about  $\frac{1}{16}$  of a line. Several of a sigmoid outline are very remarkable for the delicacy of their striae, of which may be mentioned *pleurosigma Baltica*, *P. hippocampus*, but more particularly *P. angulata*. The lines of striation upon *Nitzschia sigmoidea* are about  $\frac{1}{100000}$  of an inch apart. In *fragilaria* we have long threads of frustules adhering with considerable firmness at their commissures; but in *diatoma* they adhere only at a single point, so as to form curious chains of divided or separated joints. Prof. Bailey describes *bacillaria paradoxa* as a very interesting species, presenting by its curious motions and its paradoxical appearance an object well calculated to astonish all who behold it. At one moment the needle-shaped frustules lie side by side, forming a rectangular plate; suddenly one of the frustules slides forward a little way, the next slides a little also, and so on through the whole number, each, however, retaining a contact through part of its length with the adjoining ones. By this united motion the parallelogram is changed into a long line; then some of the frustules slide together again, so that the form is then much like a banner. Similar motions are constantly going on, and with such rapidity that the eye can scarcely follow them. The cause of this motion is wholly unknown, but it is probably mechanical and not vital. Mr. Smith, in his work on the diatomaceæ, estimates this motion as being  $\frac{1}{2000}$  inch per second. In *meridion vernale* we have one of the most beautiful of the freshwater diatoms. It consists of spiral or helicoidal chains, to perceive which the specimens must be tilted on edge. It occurs in immense quantities in mountain brooks, covering every sub-

merged stone, or twig, or spear of grass, in the early days of spring. Among the groups with vittate or ribbon-like fronds, we may notice *striatella arcuata*, occurring in vast quantities on

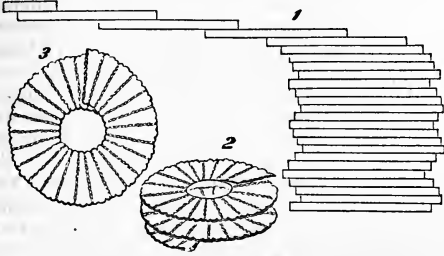

1. *Bacillaria paradoxa*. 2, 3. *Meridion vernale*.

the filiform marine algae, and covering them so much oftentimes as to make them glitter in the sunbeams as if invested with crystals. In still another natural group, where the striæ are no longer visible in the frustules or fronds, we find a multitude of microscopic objects, furnishing sources for fresh admiration whenever they are examined. In some of these the fronds, which are disciform, are marked with radiating lines, of which *coscinodiscus*, very common in a fossil state in the Richmond earth and elsewhere, is most beautiful. In *C. lineatus* the cellules of the frond form parallel lines in whatever direction they may be viewed, and *C. oculus iridis* gives curious colored rings. When perfect, the disk of *coscinodiscus* is covered with circular spots in rows corresponding with the radii. In consequence of this arrangement they also form beautiful spiral rows in other directions, so that the curves present no inconsiderable resemblance to patterns produced by engine-turning; at other times the spots are found to form three sets of lines, making angles of 60° and 120° with each other; and on others the spots are disposed without much apparent regularity, frequently having a star-like figure in the centre. The spots are so small on some of the disks as to be almost invisible even by the highest magnifying powers; on others they are quite large and hexagonal. In *podiscus Rogerii* (Bailey), the whole surface is so beautifully punctate that no engraving could do it justice. The most complicated markings on the *coscinodiscus* scarcely rival the elaborate ornaments of this truly elegant organism. It has proved very common in Virginia and Maryland in a fossil condition. The beauty of *isthmia obliquata*, detected in the mud of Boston harbor, can only be appreciated by ocular examination. The diatomaceæ enter largely into the food of the mollusca. Dr. Hooker found *dictyocha aculeata* in the stomachs of salpæ taken off Victoria Land, and remains of diatomaceæ occurred in the same ascidiuans examined between the latitudes of the N. tropic and 80° S. The medusæ are also in particular often filled with these forms.—See Bailey in “American Journal of Science and Arts,” vols. xli, xlvi.;

“Proceedings of the Essex Institute,” vol. i., pp. 33–48, and vol. ii., pp. 70, 71; Kützing’s *Species Algarum* (Leipzig, 1849); Smith’s “British Diatomaceæ” (2 vols. 8vo, London, 1853–’6); and Berkeley’s “Introduction to Cryptogamic Botany” (London, 1857).

**DIAZ, Miguel**, an Aragonese explorer, born after the middle of the 15th century, died about 1514. He took part in the second expedition of Columbus, and having arrived in Hayti in 1495, he became involved in a duel which forced him to flee to the southern part of the island, where he married the female ruler of an Indian tribe. From information given by her, and with the coöperation of Bartholomew Columbus, who was governor of the colony, he discovered the gold mines of St. Christopher, and afterward took a conspicuous part in the foundation of Nueva Isabella (afterward Santo Domingo) in the vicinity of the gold districts. He faithfully adhered to Columbus until his death.

**DIAZ DEL CASTILLO, Bernal**, a Spanish adventurer and chronicler, born in Medina del Campo, Old Castile, near the close of the 15th century. He went to seek his fortune in the new world in 1514, and joined the expeditions which sailed from Cuba to Yucatan under Fernandez de Cordova in 1517, and under Grijalva in 1518. He afterward attached himself to the fortunes of Cortes. In 1568 he was regidor of the city of Guatemala. When Gomara’s “Chronicle of New Spain” appeared, Diaz began his *Historia verdadera de la conquista de la Nueva España*, the object of which was to correct the many misstatements of his rival, and to claim for himself and his comrades a share of the glory which Gomara gave almost wholly to Cortes. The work was finished in 1558, and was first published at Madrid in 1632. An English translation by Lockhart appeared in 1844.

**DIAZ DE SOLIS, Juan.** See SOLIS.

**DIBDIN, I. Charles**, an English song writer and composer, born in Southampton in 1745, died July 25, 1814. He was the 18th child of his parents, who intended him for the church; but he studied music, and at the age of 16 went to London, where he at first supported himself by composing ballads for the music sellers and by tuning pianos. In 1763–4 the opera of “The Shepherd’s Artifice,” written and composed by him, was produced at Covent Garden theatre, after which he appeared for several years as actor and composer. Among his most popular works were “The Padlock,” “The Deserter,” “The Waterman,” and “The Quaker,” produced at Drury Lane under the management of Garrick. Having quarrelled with the latter, he was for several years engaged in various theatrical speculations, and in 1789 instituted a species of musical entertainment, in which he was the sole author, composer, and performer. He called it “The Whim of the Moment.” So successful did the enterprise prove, that in 1796 he erected a small theatre

in Leicester fields, called Sans-Souci, in which he performed till 1805, when he retired from professional life. A pension of £200 was procured for him, of which in 1806 he was deprived by the whig ministry of Lord Grenville. The tory administration, which came into power the succeeding year, restored his name to the pension list, but his improvidence kept him in poverty until his death. His theatrical compositions, 47 of which are enumerated in the "Biographia Dramatica," amount to about 100. But his reputation rests mainly upon his songs, of which he wrote 900, or as some say 1,200. His nautical songs and ballads are among the finest in the language; and some of them, like "Poor Tom Bowling," written on the death of his brother Thomas, a sea captain, and "Poor Jack," are established favorites. They were set to simple and expressive melodies, and were exceedingly popular at the beginning of the present century. He published "A Complete History of the Stage" (5 vols. 8vo, 1795), an autobiography prefixed to a collection of his songs (4 vols. 8vo, 1803), and some miscellaneous works of no great value. A new edition of his songs, with a memoir by his son Thomas, illustrated by George Cruikshank, was published in London in 1850. **II. Thomas**, son of the preceding, born in London in 1771, died there, Sept. 16, 1841. He adopted the profession of his father, and for many years appeared before the public as actor, author, and composer. His songs and dramatic pieces are probably as numerous as those of his father, but are now comparatively forgotten. He published a "Metrical History of England" (2 vols. 8vo, 1813), and "Reminiscences" (2 vols., 1828). He died in poverty, while employed in compiling an edition of his father's sea songs, for which he received an allowance from the lords of the admiralty. **III. Thomas Froggall**, an English bibliographer, nephew of Charles Dibdin, born in Calcutta in 1776, died Nov. 18, 1847. He was educated at Oxford and studied law, but afterward took orders, and received the degree of doctor of divinity. In 1807 he became editor of a weekly journal called "The Director," and in 1809 published in the form of a dialogue his "Bibliomania," reprinted with great enlargements in 1811 (new ed., enlarged, 2 vols. royal 8vo, 1842). In 1818 he travelled abroad, and in 1824 was appointed rector of St. Mary's, Bryanstone square, which post he held until his death. In 1814-'15 he published, under the title of "Bibliotheca Spenceriana," an account of the rare books in Earl Spencer's library, to which he afterward added a description of the earl's seat at Althorp, and an account of the Cassano library purchased by him, the whole in 7 vols. 8vo. His principal works besides those above mentioned are: "Introduction to a Knowledge of rare and valuable Editions of the Greek and Roman Classics" (1802; 4th ed., entirely rewritten, 2 vols. 8vo, 1827); "Typographical Antiquities of Great Britain" (4 vols., 1810-

19); "Bibliographical Decameron" (3 vols., 1817); "Bibliographical, Antiquarian, and Picturesque Tour in France and Germany" (3 vols., 1821); "Reminiscences of a Literary Life" (2 vols., 1836); "Bibliographical, Antiquarian, and Picturesque Tour in the Northern Counties of England and Scotland" (3 vols., 1838).

**DIBRANCHIATES**, a division of cephalopod mollusks, having two gills or branchiae, an ink gland, and, with few exceptions, a rudimentary internal shell. The division includes the argonaut, cuttle fish, octopus, squid, and spirula, of living forms, and the extinct belemnites. All are naked-skinned except the argonaut or paper nautilus, the female of which has a single-chambered shell for the protection of her eggs, not connected with the body.

**DICE** (plural of die), small cubes of ivory, bone, stone, or wood, used in gaming. Each of their six faces is marked with a different number of points, from 1 to 6, in such a way that the numbers upon any two opposite sides together count 7. They are shaken and thrown from a box upon a table, and the game depends upon the number of points presented by the upper faces. This is one of the most ancient of games. Plutarch makes it an early invention of the Egyptians. Dice have been discovered in Thebes, made of bone or ivory, and similar to those in use at present. Herodotus ascribes the invention of this, as of all other games of chance, to the Lydians. It is alluded to by Æschylus and Sophocles. The chief distinction between the ancient and the modern game is, that in the former three dice were employed, and in the latter ordinarily but two are used. The Greeks gave to the various throws that were possible the names of their divinities and heroes, the best throw being called Aphrodite. This game was adopted by the Romans, and the example of some of the emperors, especially of Nero, gave it a dangerous popularity. Wealthy Romans during the declining period of the empire frequently staked their entire fortunes upon a single chance. It was introduced into France in the reign of Philip Augustus, and has continued a favorite game.

**DICE** (Gr. *Δίκη*), in Greek mythology, the goddess of justice, daughter of Zeus and Themis and sister of Eunomia (good rule) and Irene (peace). She appears as one of the Horæ, and as an attendant of the father of the gods, and in the tragedians also as an avenging and rewarding divinity. Her office was not only to punish injustice, but to reward virtue.

**DICENTRA** (Borkh.), the generic name of some showy herbaceous perennials, of which several species are found wild in the United States. Of these latter, a very delicate and singularly flowered one is *D. cucullaria* (De Candolle), called Dutchman's breeches, the form of the corolla, with its spurs, resembling that article of apparel suspended in an inverted position. These blossoms are cream-colored

tipped with white, and hang in a simple raceme upon a slender drooping scape, rising from the bosom of a set of tender, deeply cut, long-stalked leaves. Both flowers and leaves soon fade away on the approach of summer, and leave, often on the surface of the ground, clusters of little grain-shaped tubers, arranged in the form of scaly bulbs. A second species, called squirrel corn (*D. Canadensis*, De C.), has scattered, round, flattened tubers, as large as grains of Indian corn, to the resemblance to which it owes its name. Its flowers are greenish white, tinged with red, and possess the fragrance of hyacinths. It is found in rich woodlands. *D. eximia* (De C.), found in western New York and among the Alleghanies of Virginia, is larger than the others, with reddish-purple flowers on a compound, clustered raceme, and with the lobes of the leaves broadly oblong. *D. chrysantha* (Hooker and Arnott), a native of California, has large, showy, golden-yellow flowers, leaves

ed out, will flower in August and September; but for early forcing it is better to put them into pots, and suffer them to ripen away the foliage that has been produced in this condi-



*Dicentra spectabilis*.



*Dicentra cucullaria*.

2 and 3 pinnately divided, glaucous, with linear, acute segments, and a stem 2 or 3 ft. high, leafy branching. But the most beautiful of all was introduced from Japan in 1846. From thick, brittle, fleshy roots rise early in the spring numerous stout hollow stems about 3 ft. high, bearing large, spreading, deeply divided, compoundly ternate leaves of a glaucous hue, like the tree paeonias, from the axils of which issue strong flower stalks, branching into axillary and smaller racemes, loaded with large, rosy blossoms, each flower being about an inch long. In the early stage of the inflorescence the buds have a deeper tint. Several weeks elapse from the commencement of the expansion of the first blossoms until the period of blossoming is over; but sometimes a few smaller racemes will appear again toward the end of the summer. This is *D. spectabilis*, popularly called "bleeding heart." Side shoots or cuttings taken off early in spring, and plant-

tion, in preparation for another season, taking due care lest they strike their freely growing root fibres through the bottom of the pots. On the approach of severe frost, the pots should be placed under shelter, or put into the cellar, whence they are to be removed into a warmer atmosphere as they are needed for flowering. For early blossoming parlor plants there are few so easily prepared, or so sure of successful management, or which will so well reward any attention. The *D. spectabilis* thrives in any good soil, but that which is light, rich, and deep suits it best. By a curious error many writers call the plant *dielytra*.

**DICK, Thomas**, a Scottish author, born near Dundee, Nov. 24, 1774, died at Broughty Ferry, July 29, 1857. He was educated for the ministry, and was settled at Stirling; but he relinquished his profession, and for ten years was engaged as a teacher at Perth. While there he wrote "The Christian Philosopher" (1823), which brought him considerable reputation. From this time he devoted himself to the writing of popular scientific works, which were not a source of much pecuniary profit to their author. He also delivered many popular lectures on scientific subjects. His works having had a large sale in the United States, a subscription was taken up for his benefit in this country some years before his death, and by this means, and the aid of a small pension from the British government, he was enabled to pass his latter years in comfort. Among his works are: "Philosophy of Religion" (1825), "Improvement of Society by the Diffusion of Knowledge," "Philosophy of a Future State" (1828), "Mental Illumination of Mankind" (1835), "Celestial Scenery" (1838), "Sidereal Heavens" (1840), and "Telescope and Microscope" (1851).

**DICKENS, Charles**, an English novelist, born at Landport, a suburb of Portsmouth, Feb. 7, 1812, died at Gadshill, near Rochester, June 9, 1870. He was baptized as Charles John Huffham, and occasionally subscribed that name. His father, John Dickens, was a clerk in the navy pay office, stationed at Portsmouth dockyard, and Charles was the second of eight children. When he was four years old his parents removed to Chatham, where his education began, and where at the age of nine he produced a tragedy called "Misnar, the Sultan of India," founded on one of the "Tales of the Genii," which, with "Don Quixote," "Gil Blas," "Robinson Crusoe," and the novels of Fielding and Smollett, he had found in the house and eagerly devoured. The next year his father became bankrupt and was imprisoned, and the family moved to Bayham street, one of the poorest quarters of London, whence Charles was sent to work in a blacking manufactory. But the father, having received a small legacy, retrieved himself somewhat, became a reporter for the "Morning Chronicle," and placed his son, after two years of schooling, in an attorney's office. The drudgery of this place was not agreeable to the boy, who continued to give all his spare time to the reading of novels, and visited the theatre whenever he could command the means. In the course of a year or two he determined to become a parliamentary reporter, and set himself diligently to the study of shorthand. In this capacity, at the age of 19, he was employed by the "True Sun," and at 23 by the "Morning Chronicle." In the "Old Monthly Magazine" for January, 1834, appeared his first published sketch, "Mrs. Joseph Porter over the Way." Similar sketches appeared in the succeeding numbers of the year, under the signature "Boz;" and they were then discontinued because their author demanded pay, which the publisher was indisposed to give. The signature "Boz" was a kind of mispronunciation of the name Moses, which was in the family given to a younger brother of Dickens, from a fancied resemblance to the Moses in Goldsmith's "Vicar of Wakefield." These sketches were continued for a year in the evening edition of the "Chronicle," and attracted considerable attention. Dickens received for them two guineas a week in addition to his regular salary of five guineas. In 1836 they were collected and published in two volumes, illustrated by Cruikshank. In April of this year he married Catharine, eldest daughter of George Hogarth, a writer for the "Chronicle;" and about the same time the first number of "The Posthumous Papers of the Pickwick Club" was announced. The firm of Chapman and Hall had proposed to Dickens a work of fiction in monthly numbers, of which he should furnish the letterpress, and Mr. Seymour, a comic artist of some celebrity, the illustrations. Seymour died by his own hand just before the second number appeared, and Hablot K. Browne (under the pseudonyme of

"Phiz") took his place. The first two or three numbers were not remarkably successful; but after that, especially when Sam Weller appeared in the fifth number, the work gained rapidly, until at its completion Dickens was the most popular writer in the language. "The Pickwick Papers" were published collectively in 1837. Meanwhile he had begun "Oliver Twist" in "Bentley's Miscellany," the first numbers of which were appearing simultaneously with the last of "Pickwick;" it was published in book form in 1838. In January of that year he assumed the editorship of "Bentley's Miscellany," but soon relinquished it. The "Memoirs of Joseph Grimaldi" appeared in 1838, with the name of Dickens as editor; but he really contributed nothing to the book but the preface. "Nicholas Nickleby" was published in monthly numbers from April, 1838, to October, 1839. In 1838 he published anonymously a small volume of sketches entitled "Young Gentlemen," and soon afterward another entitled "Young Couples." Under the general title of "Master Humphrey's Clock," "The Old Curiosity Shop" and "Barnaby Rudge" appeared in monthly numbers during 1840 and 1841, but subsequently were published as distinct stories. In the latter year he travelled in the highlands of Scotland, taking his work with him and writing at it regularly. On his return he wrote many political squibs, some of them in verse, directed against the Tories. In January, 1842, Dickens and his wife sailed for America, landing at Boston on the 22d. Of that visit neither Mr. Dickens nor the American people had reason to be proud. On their part he was received and feted with an admiration which degenerated into snobbishness; and on his part the liberal but often ridiculous hospitality was repaid in the "American Notes" and "Martin Chuzzlewit" with sneers and caricature. He returned to England in June, and published "American Notes for General Circulation" toward the close of the year. In 1843 he wrote "The Christmas Carol," the first of a series of short stories for the holidays, in which benevolence, generosity, and kindly sympathy are inculcated. These stories have met with a popular appreciation not surpassed by his novels, and several of them have been dramatized. The titles and dates of the others are as follows: "The Chimes" (1844); "The Cricket on the Hearth" (1845); "The Battle of Life" (1846); "The Haunted Man and the Ghost's Bargain" (1848); "Dr. Marigold's Prescriptions" (1865), of which 250,000 copies were sold in England in one week; "Mugby Junction" (1866); and "No Thoroughfare" (1867). The last two were written in collaboration with others. "Martin Chuzzlewit" was published in 1844, and in July of that year Dickens went to Italy, where he resided about a year. On Jan. 1, 1846, he became editor of the "Daily News," a newly established morning journal of liberal politics, and in this his "Pictures from Italy" were first published. As a politi-

cal editor he was not successful, and at the end of four months his connection with the "News" was terminated. "Dealings with the Firm of Dombey and Son" was published serially in 1847-'8, and "David Copperfield" in 1849-'50. In 1850 Dickens started "Household Words," a weekly periodical, in which appeared his "Child's History of England" (1852) and "Hard Times" (1854). It is said to have attained a circulation of 90,000 in Great Britain. "Bleak House" appeared serially in 1852-'3, and "Little Dorrit" in 1856-'7. In 1858 Dickens and his wife arranged an amicable separation for reasons which have never been fully given to the public. In 1859, incidental to this separation, he had a disagreement with the publishers of "Household Words," which ended in his buying out their interest and suspending the publication. He then started "All the Year Round," a similar periodical, and in this appeared "A Tale of Two Cities" (1860), "Great Expectations" (1861), and "The Uncommercial Traveller." "Our Mutual Friend" was published in monthly numbers in 1864-'5. In this form also he commenced publishing in April, 1870, "The Mystery of Edwin Drood," which was uncompleted at the time of his death. Besides the works already enumerated, he produced a number of short stories, no complete collection of which has yet been made. Among them are "Chops the Dwarf," "The Holly Tree Inn," "Mrs. Lirriper's Lodgings," "Mrs. Lirriper's Legacy," and "A Child's Dream of a Star."—Dickens's works began a new era in fictitious literature. No predecessor had made so many studies from actual and ordinary life, from the scenes and characters nearest at hand, or had been so imaginative in their delineation; and no novels had appealed so powerfully to the universal sympathies and best impulses of mankind. They are full of faults in plot, in style, and in character, and there is scarcely one of them that could not be improved by cutting out extraneous matter; but their great excellences override everything, and captivate every reader who has the slightest interest in the common virtues and foibles, or sympathy with the common joys and sorrows of humanity. Most of them are written with a purpose, more or less obvious, beyond the mere production of a story. Thus "Oliver Twist" exposes the abuses of the poorhouse system and the training of boys to crime; "Nicholas Nickleby" was aimed at the horrors of cheap boarding schools; "Hard Times" delineates the sufferings of the manufacturing population, "Bleak House" the delays of the court of chancery; while "Our Mutual Friend" has for its theme the idea that prosperity only expands natural goodness and intensifies natural meanness. Almost all of them, however, attack some form of vice, or social wrong, or abuse of power. None of them deal with the past, except "Barnaby Rudge" and "A Tale of Two Cities." They have all gone through numberless editions in

England and America; but they have not borne very well the test of translation, and are not so popular in foreign languages as in English, for the obvious reason that much of their charm depends on a kind of humor peculiar to the Anglo-Saxon race, and is often conveyed in idioms that are not translatable.—Dickens always had a love for the drama, and was a frequent performer in private theatricals. He wrote an opera and a few farces and light comedies, one of which was afterward transformed into his burlesque story of "The Lamplighter." In 1851 he organized, with other authors and artists, a company of amateur actors, under the name of "Guild of Literature and Art," intended for the special benefit of authors, artists, and actors; and considerable charitable funds were raised by their performances, notably that for the relief of the family of Douglas Jerrold. Having often given readings of his shorter stories for benevolent objects, in April, 1858, Dickens first appeared in London as a public reader for his own benefit; and from that time he read frequently in the chief cities of Great Britain and Ireland, giving a course also in Paris. In November, 1867, he visited the United States for the same purpose, and gave his first reading in Boston, Dec. 2, his last in New York, April 20, 1868. His tour comprised the chief cities of the eastern and middle states, but extended no further west than Buffalo. The success of these performances on both sides of the Atlantic was probably beyond his own expectations. Artistically they were almost perfect, for Dickens was an excellent actor, and gave long and hard study to the minutest details. Financially they were more profitable than all his publications had been. He gave his last reading in England on March 15, 1870.—Few literary men have ever maintained so large an interest as Dickens in whatever was going on around them; and scarcely one has so well exhibited his ability for taking care of his own business affairs. His share in the profits of his first two or three books was comparatively small; but thereafter he always dictated the terms to his publishers, and looked sharply after his own interests. It had been his dream when a boy to own Gadshill house, which he frequently passed by and admired; and in 1857 he purchased it and made it his home. His first visitor there was Hans Christian Andersen, and for 13 years it was the scene of a generous hospitality. Dickens had few of the hobbies and superstitions that are generally supposed to be inseparable from genius; one, however, is noticeable: having been out of London when the first number of "Pickwick" appeared, he invariably left town just before the publication of the initial numbers of his subsequent stories.—On June 8, 1870, as he sat down to dinner, it was observed that he appeared unwell, but he declared that he was only suffering from a toothache, and declined to have a physician called. At the same time he requested that

the window should be closed, and immediately sank into a stupor, from which he never rallied. With no returning gleam of consciousness, he died the next evening. The cause of his death was apoplexy, brought on by overwork. He left five sons and two daughters, and bequeathed to them the greater portion of his estate. He had refused a baronetcy offered him by the queen, and in his will he wrote: "I emphatically direct that I be buried in an inexpensive, unostentatious, and strictly private manner; that no public announcement be made of the time or place of my burial. . . . I direct that my name be inscribed in plain English letters on my tomb, without the addition of 'Mr.' or 'Esquire.' I conjure my friends on no account to make me the subject of any monument, memorial, or testimonial whatever. I rest my claims to the remembrance of my country upon my published works, and to the remembrance of my friends upon their experience of me. In addition thereto I commit my soul to the mercy of God, through our Lord and Saviour Jesus Christ, and I exhort my dear children humbly to try to guide themselves by the teachings of the New Testament in its broad spirit, and to put no faith in any man's narrow construction of its letter here or there." Dickens was buried privately in the poets' corner of Westminster abbey. He never furnished any materials for a biography; but it is supposed that "David Copperfield," which is very generally considered his best novel, is largely autobiographical in fact, as it is in form. John Forster, his intimate friend and one of his executors, has written his biography in three volumes (London, 1872-'4; reprinted in Philadelphia). See also "Life of Charles Dickens," by R. Shelton Mackenzie (Philadelphia, 1870); "The Dickens Dictionary," by Gilbert A. Pierce (Boston, 1872); and "The Cyclopædia of Dickens," by F. G. de Fontaine (New York, 1873).

**DICKINS, John**, an American clergyman, born in London, Aug. 24, 1747, died in Philadelphia, Sept. 27, 1798. He studied at Eton, emigrated to America before the revolution, and was one of the prominent founders of the Methodist Episcopal church in America, suggesting the name which was adopted. From 1776 to 1782 he preached in Virginia and North Carolina. As early as 1780 he suggested to Bishop Asbury the plan of Cokesbury college, at N. Abingdon, Md., the first Methodist academic institution in America. In 1783 he took charge of the John street church, New York, and was the first American preacher to receive Thomas Coke and approve his scheme for organizing the denomination. In 1789 he was stationed in Philadelphia, and there established the "Methodist Book Concern" (afterward removed to New York), commencing it with \$600 lent by himself to the church, and continuing in charge of it till his death.—His son, **ASBURY DICKINS**, born July 29, 1780, was in 1801 associated with Joseph Dennie in found-

ing the "Port Folio" at Philadelphia. He was first clerk in the United States treasury department from 1816 to 1833, and in the state department from 1833 to 1836, when he was elected secretary of the United States senate, which office he held till July 16, 1861. While in the treasury and state departments he was often acting secretary, and wrote many important state papers. He died in Washington, Oct. 23, 1861.

**DICKINSON. I.** A N. W. county of Iowa, bordering on Minnesota; area, 430 sq. m.; pop. in 1870, 1,389. It contains a number of small lakes, the principal of which is Spirit lake. The largest river is the Okoboji, an affluent of the Little Sioux. The chief productions in 1870 were 21,871 bushels of wheat, 20,541 of oats, 5,267 of Indian corn, and 3,267 tons of hay. The total value of live stock was \$81,470. Capital, Spirit Lake. **II.** A N. W. central county of Kansas, intersected by the Kansas river, and watered by its affluents; area, 846 sq. m.; pop. in 1870, 3,043. The surface is mostly prairie, but somewhat diversified. The soil is fertile. The Kansas Pacific railroad traverses it. The chief productions in 1870 were 55,312 bushels of wheat, 97,615 of Indian corn, 21,628 of oats, 10,349 of potatoes, 11,115 tons of hay, and 41,161 lbs. of butter. There were 1,153 horses, 1,494 milch cows, and 5,157 other cattle. Capital, Abilene.

**DICKINSON, Anna Elizabeth**, an American lecturer and author, born in Philadelphia, Oct. 28, 1842. She was the youngest of five children, whose father died when she was two years old, leaving his family in poverty. She received her early education in the free schools of the society of Friends, to which her parents belonged. At the age of 14 she made her first appearance in print, with an article on slavery in the "Liberator." At 17 she left school, and during the next two years taught at New Brighton and in Bucks co., Pa. Her first speech was made in a meeting of the association of Progressive Friends in Philadelphia, in January, 1860, the subject being "Woman's Rights and Wrongs;" and from this time she began to speak frequently in such assemblies, chiefly on temperance and slavery. Meanwhile she obtained employment in the United States mint at Philadelphia. But in November, 1861, in a speech alluding to the action at Ball's Bluff, she said, "This battle was lost, not through ignorance and incompetence, but through the treason of the commanding general;" for which she was dismissed from the mint. Thereupon she made lecturing her profession, speaking chiefly on political topics. Early in 1863 she accepted an invitation from the republican state committee of New Hampshire to enter the canvass for the March election. Afterward she accepted an invitation to make a similar tour in Connecticut; and in the autumn of the same year she was engaged by the republican committee of Pennsylvania to speak in the mining and agricultural dis-



tricts of that state. She opposed the reelection of President Lincoln in 1864, and advocated the election of Horace Greeley to the presidency in 1872. For several years she has held a place among the regular lyceum lecturers, and has spoken in almost every part of the country. She has published a novel entitled "What Answer?" (Boston, 1868).

**DICKINSON, John**, an American statesman, born in Maryland, Nov. 13, 1732, died in Wilmington, Delaware, Feb. 14, 1808. He studied law in Philadelphia, and subsequently at the Temple, London, and on returning to America practised with considerable success. Being elected to the Pennsylvania house of assembly in 1764, he evinced unusual capacities, and was a ready and energetic debater. At the same time he became known by his publications upon the attempts of the mother country to infringe the liberties of the colonies. In 1765 he was elected a deputy from Pennsylvania to the first colonial congress, and drafted the resolutions passed by that body. In 1768 he published his "Farmer's Letters to the Inhabitants of the British Colonies," which were republished in London with a preface by Benjamin Franklin, and subsequently in French in Paris. He was a member of the first continental congress in 1774, and of the state papers put forth by that body some of the most important, including the "Declaration to the Armies," the two petitions to the king, and the "Address to the States," were the production of his pen. He, however, opposed the adoption of the declaration of independence, believing that the movement was premature, and that compromise was still practicable, and was one of the few members of congress who did not sign it. So unpopular did he become with his constituents for his course on this occasion, that for several years he was absent from the public councils, although in the interim he signified his devotion to the American cause by serving as a private soldier in Delaware. In 1779 he returned to congress as a member from Delaware, and wrote the "Address to the States" of May 26. He was subsequently president of the states of Delaware and Pennsylvania successively, and a member of the federal convention for framing a constitution. In 1788 appeared his "Fabius" letters, advocating the adoption of the new constitution. Another series over the same signature, on the relations of the United States with France, published in 1797, was his last work. His political writings were published in 2 vols. in 1801.

**DICKINSON COLLEGE**, the name of a college of the Methodist Episcopal church, situated at Carlisle, Pa. It was founded in 1783 as a Presbyterian institution, and named after John Dickinson, president of Pennsylvania, in consideration of his valuable gifts for its establishment, and his great personal interest in it. It remained Presbyterian till 1833, when, in consequence of the embarrassments caused by the division of that church, it was transferred to

the Methodist Episcopal church. The Presbyterian presidents of the institution were Charles Nisbet (elected in 1784), Robert Davidson (1804), Jeremiah Atwater (1809), John M. Mason (1821), William Neill (1824), and Samuel M. How (1830); the Methodist presidents, John P. Durbin (1833), Robert Emory (1845), Jesse T. Peck (1848), Charles Collins (1852), Herman M. Johnson (1860), Robert L. Dashiell (1868), and James A. McCauley (1872). The list of graduates contains the names of President Buchanan, Chief Justice Taney, and Postmaster General Creswell. During the year of the centenary of American Methodism (1866) its endowment fund was increased to \$100,000. A scientific and a law department have recently been established; also a Biblical course for students preparing for the ministry. In 1873 there were 7 professors, 2 tutors, and 87 students. The college consists of three buildings; it has a valuable scientific apparatus and libraries containing about 30,000 volumes. In the junior and senior years divergences from the classical course are allowed, either in favor of the Hebrew language for those studying for the ministry, or in favor of the natural sciences. A complete catalogue, containing names of the presidents, professors, trustees, and graduates from the foundation, was issued in 1864.

**DICKSON**, a N. county of Tennessee, bounded N. E. by Cumberland river, and drained by several of its affluents; area, about 650 sq. m.; pop. in 1870, 9,340, of whom 1,677 were colored. It has a rolling surface and a tolerably fertile soil. The Cumberland river, along its border, is navigable by steamboats, and it is intersected by the Nashville and Northwestern railroad. The chief productions in 1870 were 36,130 bushels of wheat, 319,085 of Indian corn, 58,810 of oats, 98,798 lbs. of butter, and 462,130 of tobacco. There were 1,622 horses, 1,917 milch cows, 3,698 other cattle, 6,925 sheep, and 11,557 swine; 4 flour mills, 4 saw mills, and 2 manufactories of pig iron. Capital, Charlotte.

**DICKSON, Samuel Heury**, an American physician, born in Charleston, S. C., in September, 1798, died in Philadelphia, March 31, 1872. He graduated at Yale college in 1814, and afterward studied medicine in Charleston and at the university of Pennsylvania. He was instrumental in the establishment of a medical college in Charleston, and on its organization in 1824 became professor of the institutes and practice of medicine. In 1832 he retired, but in the following year, on the reorganization of the institution as the medical college of the state of South Carolina, he was reelected. In 1847 he was called to the professorship of the practice of medicine in the university of New York, which he filled till 1850, when he resumed his professorship in the medical college of South Carolina. In 1858 he became professor of the practice of medicine in the Jefferson medical college at Philadelphia. He contributed many papers to various medical jour-

nals, and published a work on "Dengue" (Philadelphia, 1826); "Manual of Pathology and Practice of Medicine;" "Essays on Pathology and Therapeutics" (2 vols. 8vo, New York, 1845); "Essays on Life, Sleep, Pain, &c." (12mo, Philadelphia, 1852); and "Elements of Medicine" (8vo, Philadelphia, 1855). He was also the author of a pamphlet on slavery, in which he asserted the essential inferiority of the negro race.

**DICQUEMARE, Jacques François**, a French naturalist and astronomer, born in Havre, March 7, 1733, died March 29, 1789. He was a priest, and became professor of experimental physics at Havre, and member of the academy of Rouen and of the royal marine academy. He invented several useful instruments in connection with astronomy and navigation, but is better known by his researches into the natural history of zoöphytes, infusoria, and mollusks, and particularly by his discoveries relative to sea anemones, on which he published an essay in French and English (4to, London, 1774). He designed an instrument called the cosmoplane, by means of which he solved problems in nautical astronomy. Besides numerous papers in the *Journal de Physique*, he published an *Index géographique* (1769), *Idée générale de l'astronomie* (1769), and *Connaissance de l'astronomie* (1771).

**DICTATOR**, the chief magistrate in the cities of the ancient Latin confederacy, in Alba, Tusculum, &c. The Romans adopted the word from their Latin neighbors, and applied it in the earliest period of the republic to exceptional magistrates appointed in times of danger, with nearly absolute power over life and property, from which there was no appeal to law or people. The dictator was usually nominated by the senate, and appointed by one of the consuls for six months, during which time the consuls and other regular magistrates continued in their office, though subject to his dictates, and deprived temporarily of their badges of dignity. The power of the dictator was mostly limited to one object, and particularly to foreign affairs. Being elected, he appointed his lieutenant or master of the horse (*magister equitum*) and surrounded himself with his 24 lictors (twice as many as attended the consuls), armed with fasces and axes. He was limited only in regard to the use of the public money, and responsible only after the expiration of his term; he was not allowed to leave Italy, or to appear on horseback within the precincts of the city. Officers bearing the same title were also sometimes appointed for certain civil or religious purposes. This office was quite harmless, but in later periods dictators were appointed *reipublicæ constituendæ causa* (to form a new constitution), such as Sulla and Cæsar, whose arbitrary power destroyed the republic. The first Roman dictator, Lartius, was appointed within ten years after the establishment of the republic (about 500 B. C.), to save the state from the threatening allies of Tarquin,

the expelled king, and the more dangerous disturbances within the walls. The public lands were in the grasp of the patricians, and the plebeians were poor and degraded. The danger from the supporters of Tarquin was imminent. The senate commanded new levies, but the people refused to obey, declaring that they had nothing to defend, and that no foreign yoke could bring upon them greater hardships than those they endured. In their disobedience they were protected by the law recently passed through the efforts of Valerius Poplicola, which permitted every citizen condemned to any severe punishment to appeal to the people. To evade the force of this popular law, the senate agreed upon the extraordinary measure of electing a single magistrate with more than regal power. The people confirmed the decree, and the success and honesty of Lartius proved worthy of the new dignity. About two years later another dictator, Aulus Posthumus, destroyed the last hopes of the banished king, in a battle fought near Lake Regillus. Not less remarkable were the services of the dictator L. Quintius Cincinnatus, who, having accomplished the object of his appointment by routing the Æqui and saving the surrounded consular army, resigned his dignity within 17 days. C. M. Rutilus (356) was the first plebeian appointed to the dictatorship, and M. J. Perà (216) was the last dictator in the original sense of the word; for the same dignity, as bestowed on Sulla (82), and three times on Cæsar (47, 45, and 44), meant only unlimited, despotic sway. Mark Antony abolished it altogether.

**DICTIONARY** (Lat. *dictio*, a word), in its ordinary acceptation, a book containing the words of a language, in alphabetical order, with a definition annexed to each. The title of dictionary is also sometimes given to alphabetically arranged cyclopædias; as dictionaries of law, of medicine, of the arts, of sciences, of commerce, &c. (See CYCLOPÆDIA.) A complete dictionary would fulfil the same office with respect to language that a universal cyclopædia fulfils with respect to arts, sciences, and literature, giving an account of the origin and applications of the verbal symbols of ideas and facts, as the latter gives an account of the ideas and facts themselves. It would, therefore, state the etymology of words, and note their variations in meaning through the successive periods of a literature. A glossary is a dictionary of obsolete, provincial, or technical words; and the term lexicon, though hardly distinguished by usage from dictionary, is more frequently applied to vocabularies of the ancient and learned languages, with the definitions and explanations in some modern language. The earliest dictionary known is probably the series of clay tablets covered with cuneiform inscriptions which were found in the ruins of a palace of Nineveh, and which are ascribed to the time of the Assyrian king Asshur-bani-pal, whose seal is impressed on them. They are divided into

two, and occasionally into three and even four vertical columns, in which complicated ideographic or monographic signs are explained in the more simple and phonetic syllabary of the time. Dictionaries, though not approaching the modern arrangement so closely as do these Assyrian tablets, were also in use in very ancient times among the Chinese and Japanese. The Greeks and Romans appear not to have employed dictionaries in learning foreign languages, but uniformly to have availed themselves of conversation with foreigners. Nor have any early attempts at Greek lexicography been preserved. The oldest extant Greek dictionary is by Apollonius of Alexandria, a contemporary of Augustus, whose "Homeric Lexicon" (*Λέξεις Ὀμηρικαί*), though much interpolated, has been of value in modern times in interpreting the idioms of the *Iliad* and *Odyssey*. Erotianus, a Greek writer in the reign of Nero, made a glossary of all the learned words found in Hippocrates. Subsequent Greek dictionaries were the *Onomasticon* of Julius Pollux (about A. D. 177), containing explanations of the most important words relating to various prominent subjects, the arrangement being topical instead of alphabetical; the dictionary (*Ἑκλογία*) of Attic words and phrases, by Phrynichus, an Arabian or Bithynian, who lived under Marcus Aurelius; the dictionary of the words that occur in Plato, by Timæus the sophist, probably of the 3d century, which, though brief, contains the best explanations of terms that have come down from the ancient grammarians; a lost universal lexicon by Diogenianus of Heraclea, which is often quoted by Hesychius and Suidas, and which was abridged from an elaborate work by Pamphilus, also lost; the dictionary to the works of ten Attic orators, by Valerius Harporation, of unknown date, compiled from works now lost, and of the highest importance for its explanations of legal and political terms, and its accounts of persons and things mentioned in the Attic orations; the comprehensive Greek dictionary of Hesychius, an Alexandrian grammarian of the 4th century, which, though much disfigured and interpolated in its present form, is a vast accumulation of most heterogeneous materials, and has been a principal source of our knowledge of the Greek language and of many ancient customs; the lexicon (*Λεξέων Συναγωγή*) attributed to Photius, patriarch of Constantinople (died about 890); and the Greek lexicon ascribed to Suidas, of unknown date, first quoted in the 12th century, containing both common and proper names alphabetically arranged, and valuable for the literary history of antiquity, and for its citations from ancient authors, as well as for its explanation of words.—The first Roman writer on lexicography was M. Terentius Varro, the friend of Cicero; but his work, *De Lingua Latina*, is rather a voluminous treatise on the etymology and peculiar uses of words than a dictionary; only fragments have been preserved.

The elaborate work of Verrius Flaccus, in the earlier part of the 1st century, entitled *De Significatu Verborum*, is lost; but it was the basis of a valuable compilation by Pompeius Festus, in the 3d or 4th century, entitled *De Significatione Verborum*, which was abridged by Paulus Diaconus in the 8th century. Only one imperfect copy of the work of Festus is preserved. The words are classified alphabetically according to the initial letter of each, but the order of the subsequent letters is not observed. The information which it contains has been of great importance on many obscure points connected with antiquities, mythology, and grammar. Near the middle of the 11th century Papias of Lombardy compiled a Latin dictionary from the glossaries of the 6th and 7th centuries. An indication of progressive learning in Italy in the 13th century was the *Catholicon* of Giovanni Balbi, a Genoese monk, consisting of a Latin grammar followed by a copious dictionary. The work is in Latin, forms a volume of great bulk, was written about 1286, and is now celebrated as a rare typographical curiosity, its first edition having been printed by Gutenberg in 1460. The *Cornuopia* of Perotti, bishop of Siponto, printed in 1489, was a copious commentary on Martial, followed by an alphabetical index of words, and was of much service to subsequent compilers. The first edition of Calepino's Latin dictionary appeared at Reggio in 1502. At first only a Latin lexicon, additions of the corresponding Italian, Greek, German, &c., words were successively made, till it was extended (Basel, 1590-1627) to eleven languages. The French give the name *calepin* to any voluminous compilation. An epoch in Latin lexicography was made by the publication of Robert Stephens's *Thesaurus Lingue Latine* (1532; 3d enlarged ed., 1543), which attempted to exhibit the proper use of words, not only in all the anomalies of idiom, but in every minute variation of sense. The most noted of subsequent Latin dictionaries is the *Lexicon totius Latinitatis* of Facciolati and Forcellini (Padua, 1771; 3d ed., 1831), in which every word is accompanied by its Italian and its Greek correlative, and which illustrates every meaning by examples from the classical authors. An English edition, edited by James Bailey, was published in London in 1828. Sir Thomas Elyot was the author of the first Latin-English dictionary (London, 1538), beyond the mere vocabularies of school boys. He was a distinguished scholar, and a friend of Sir Thomas More; his work reached the third edition in 1545. The largest similar work that had preceded it was the *Orbis Vocabulorum*, printed by Wynkin de Worde in 1500 (5th ed., 1518), which by successive improvements became the popular Latin-English dictionary of Ainsworth (1736, and many subsequent editions, of which the latest is the London quarto edition edited by John Carey, LL. D.; abridgment by Thomas Morell, D. D., Philadelphia, 1863). The most eminent Latin lexicographers since Forcellini

are the German scholars Scheller, Freund, and Georges. The work of Forcellini was the basis of the Latin-English dictionary of F. P. Leverett (Boston, 1836); and that of Freund, of the Latin-English lexicon of E. A. Andrews (New York, 1856). Many smaller lexicons have also been prepared for educational purposes, but nearly all are entirely formed from the material of the larger works.—The first modern Greek-Latin dictionary was that of Giovanni Crastoni of Piacenza (Milan, 1480; printed also by Aldus, 1497), which was for many years the only lexicographic aid for the student of Greek. Robert Constantine published at Basel, in 1562, a thesaurus of the Greek language, in which he had the assistance of Gesner, Turnebus, Camerarius, and other learned contemporaries. It was superseded by the *Thesaurus Græcæ Linguae* of Henry Stephens (Paris, 1572), the result of 12 years' labor, which has hardly been surpassed in the comprehensive and copious interpretation of words. Its arrangement is not in the alphabetical order of words but of roots, the derivatives and compounds being collected after each root. It was the basis of the works of Scapula and Schrevelius. The most thorough subsequent Greek lexicons are the German works of Schneider, Passow, Seiler, Rost, and Pape. The work of Passow was the basis of the Greek-English lexicon of Liddell and Scott (Oxford, 1845; New York, edited by Henry Drisler, 1848; large 4to ed., London, 1870). The Greek language was long studied through the medium of the Latin, and no Greek-English lexicon was projected until the present century. The first of these that was announced was that of John Pickering (Boston, 1826, much enlarged in 1829, and subsequently in 1846), which was partially executed in 1814. It was preceded in publication only by the similar English work of John Jones (1823); that of Donnegan, an abridged translation from the German of Schneider, appeared in 1827.—The first standard dictionaries of modern languages were produced under the patronage of learned academies. The oldest was the Italian *Vocabulario della Crusca*, first published in 1612, which was avowedly founded on Tuscan principles, made the 14th century the Augustan period of the language, and slighted the great writers of the 16th; an enlarged edition of this work (Florence, 1729-'38) still forms the highest authority for the Italian language. In Spain the lexicon of Lebrixa (1492) and the *Tesoro* of Covarrubias (1611) were the only dictionaries of note till the new academy produced its great work (6 vols., Madrid, 1726-'39), an abridgment of which was immediately prepared (5th revised ed., 1817). Though German lexicography begins with Hrabanus Maurus, a contemporary of Charlemagne, the first noteworthy German lexicon was *Die Teutsch Sprach* of Maaler (Zürich, 1561), and the first learned and critical work of the kind was Frisch's *Deutsch-lateinisches Wörterbuch* (Berlin, 1741). All

others have been superseded successively by the work of Adelung (Leipsic, 1774-'81), and that of the brothers Grimm (Leipsic, begun in 1852.) The dictionary of the French academy was published in 1694, and adopted the alphabetical order in its 2d edition in 1718. The 6th edition was issued in 1835. A 7th edition, much improved, to be completed in 2 vols. 4to, is now (1874) in progress, and will probably be finished in 1876. M. Patin is the chief editor; MM. de Sacy, Sandeau, C. Doucet, and Mignet are associated with him. L. N. Bescherelle's excellent dictionary of the French language, in 2 vols. 4to, appeared in 1843-'6. The large and important dictionary of M. É. Littré (3 vols. 4to, 1863-'73) is remarkably full, and has taken its place among the highest authorities.—The object of the first lexicographical labors in England was to facilitate the study of the Latin language, and bilingual dictionaries had become common while those designed for merely English readers were rare and meagre productions. Probably the earliest of the latter was that of Dr. John Bullokar, entitled "The English Expositour" (London, 1616), explaining, as was announced on the title page, 5,080 of what were esteemed the "hardest words;" it passed through many editions. Subsequent works were the "Glossographia, or Dictionary of Hard Words," by Thomas Blount (London, 1656); the "New World of English Words," by Edward Phillips, the nephew and pupil of Milton (1658); and the "Universal Etymological English Dictionary," by Nathan Bailey (London, 1726), in which the first attempt was made to give a complete collection of the words of the language, and which was long in the highest repute. An interleaved copy of a folio edition of Bailey's dictionary was the repository of the articles collected by Dr. Johnson in preparing his dictionary. The work of Johnson, after eight years of arduous labor, appeared in 1755, and has exerted an influence superior to any other in fixing the external form of the language and settling the meaning of words. He first introduced into English lexicography the plan of illustrating the various significations of words by examples extracted from the best authors. It was much enlarged by Todd in the editions of 1814 and 1827, and has been the basis of many smaller works. The most important subsequent dictionaries are those of Smart, Richardson, Webster, and Worcester. Smart's dictionary, which Dr. Webster calls "most excellent," was published in 1836, at London. Richardson's "New Dictionary of the English Language" (2 vols. 4to, London, 1835-'7) is an elaborate work, especially valuable to the student of the history of the language. Its arrangement is in the alphabetical order of the primitives, beneath each of which its derivatives are grouped. Noah Webster was engaged 36 years on his "American Dictionary of the English Language," the first edition of which was

issued in 1828, in New York (2 vols. 4to), when the author was in his 70th year. A revised edition appeared in 1840 (2 vols. 8vo), with the addition of several thousand words which in the intervening 12 years had passed from technological science into common language; and a revised appendix was added in 1843. A new edition, revised and enlarged by Prof. C. A. Goodrich, was published in Springfield, Mass., in 1848 (1 vol. 4to, 1400 pages). In 1864 a still larger edition was published, with illustrations, after a revision of the work by Prof. Noah Porter of Yale college, who was aided by many able collaborators. For this edition much valuable matter has been added, such as a dictionary of noted names of fiction, names distinguished in modern biography, &c. Prof. James Hadley contributed to it a brief history of the English language, and an entire revision of the etymologies was made under the direction of Dr. C. A. F. Mahn of Berlin, Prussia. It forms a 4to volume of 1840 pages, containing about 114,000 words. Dr. J. E. Worcester's illustrated quarto dictionary, which had been preceded by two minor and preparatory works, was published in 1860, in Boston. This work, which contests with that of Webster the place of highest authority among American scholars, is the result of more than 30 years of labor, and contains about 104,000 words. The chief differences between it and Webster's dictionary are found in the spelling adopted for certain classes of words. Words like *centre*, *theatre*, &c., the last syllable of which is spelled by Worcester *tre*, and by Webster *ter*, are specimens of one of the most prominent of these classes. The participles and nouns formed from verbs ending in *el*, &c., form a still larger class; in these Worcester doubles the *l* (*traveller*, *travelling*, &c.), while Webster does not (*traveler*, *traveling*, &c.). Other differences exist, both in methods of spelling and in definition, and to some extent in pronunciation; but for the understanding of these a thorough study of the two works is necessary. (For other dictionaries, see the articles upon the different languages.)

**DICTYS OF CRETE**, the reputed author of a history of the Trojan war. The MS., written in Phœnician characters, but in the Greek language, is said to have been found in the author's tomb at Cnossus in the reign of Nero. A Latin version in six books has come down to us, but the work is commonly regarded as a forgery. Dictys is said to have followed Idomeneus, king of Crete, to the siege of Troy, and some ancient grammarians have imagined that Homer drew materials for the Iliad and Odyssey from his history. It was the chief basis of the mediæval literature relating to the siege of Troy, and was among the first books printed in the 15th century.

**DIDEROT**, Denis, a French writer and philosopher, born in Langres, Oct. 5, 1713, died in Paris, July 30, 1784. He was the son of a cutler, and was first educated for the church,

but soon gave up theology to enter an attorney's office in Paris. Law, however, did not occupy his time so much as literature and science. Failing to select a profession, he was deprived of his allowance by his father, and for a time obtained a livelihood by teaching. He married unfortunately, translated a history of Greece, wrote sermons, and furnished articles for a dictionary of medicine. In 1745 he wrote his *Essai sur le mérite et la vertu*, and in 1746 his *Pensées philosophiques*, the boldness of which was punished by a sentence of the parliament, and *Bijoux indiscrets*, a collection of obscene tales, of which he himself was ashamed. His *Lettres sur les aveugles à l'usage de ceux qui voient* (1749) procured him at once an acquaintance with Voltaire and three months' imprisonment at Vincennes, where he was often visited by Rousseau. On his liberation, in conjunction with D'Alembert, he framed the plan of the work upon which his reputation is mostly founded, the *Encyclopédie*. Its professed aim was to present in a single work the truths of science, the principles of taste, and the processes of all the arts; but it was in fact a vehicle for the diffusion of new ideas. He wrote nearly all the articles on ancient philosophy, and all those on the trades and industrial pursuits; and after the withdrawal of D'Alembert he had the supervision of the whole. Two volumes of the *Encyclopédie* appeared in 1751; but they were suppressed, and the printing of others was forbidden during 18 months, owing to its alleged hostility to Christianity. This suspension was revoked, and five new volumes had appeared in 1757, when it was again assailed with a tempest of denunciations, the result of which was a second suspension of the work. D'Alembert deserted his partner, and Voltaire subsequently advised Diderot to leave the country, and complete his work enjoying the hospitality of Catharine of Russia. He, however, struggled against all obstacles, and was finally permitted to continue the publication at Paris, without subjecting it to censorship; but on the title page Neufchâtel was to be printed instead of Paris, and the name of the editor was left blank. The ten additional volumes were thus produced with no further difficulty. While engaged on the *Encyclopédie*, Diderot wrote books of various kinds in his own name, and greatly contributed to those by his friends. Thus a large portion of Raynal's history of the Indies belongs to him, while the most eloquent pages of *De l'esprit*, by Helvétius, and of the *Système de la nature*, by D'Holbach, are attributed to his pen. The artistic part of Grimm's correspondence, known as *Les salons*, was written by him, and several letters on different subjects bear unmistakable marks of his hand. Diderot was always ready to help the needy, and his personal influence could scarcely be overrated. In 1757 and 1758 he produced two domestic dramas, *Le fils naturel* and *Le père de famille*, which paved the way

to the change afterward accomplished in the dramatic style in France. His industry brought him money, but his careless manner of spending it and his dissipated habits frequently involved him in pecuniary difficulties. In 1765 he was forced to offer his library for sale. Catharine II. of Russia purchased it for 15,000 francs, but on condition that he would be the keeper of it at a salary of 1,000 francs a year; she moreover ordered 50 years' income to be paid at once. When the *Encyclopédie* was completed, Diderot paid a visit to his protectress, and spent several months at her court, where he was treated with great respect. On his return to Paris he published two novels, *Jacques le fataliste* and *La religieuse*, and in 1779 his *Essai sur les règnes de Claude et de Néron*, which is merely an encomium of Seneca. His later years were passed in comparative quiet and comfort. He had been all his life considered an atheist, but during his last year he was frequently visited by the curate of St. Sulpice, with whom he was pleased to talk on religious subjects; and if he did not consent to any recantation of his philosophical opinions, he showed no particular enmity to Christianity. He left an only daughter, Mme. de Vandeuil, who wrote *Mémoires* of his life. His friend Nageon published an edition of his works in 15 vols. 8vo, 1798; but a more complete one, in 22 vols., appeared in 1822. To this must be added his *Mémoires et œuvres inédites*, 4 vols. 8vo, printed in 1830.—See *Diderot's Leben und Werke*, by Rosenkranz (Leipsic, 1866).

**DIDIUS SALVIUS JULIANUS**, Marcus, Roman emperor for a short time under the name of Marcus Didius Commodus Severus Julianus, born about A. D. 133, killed June 1, 193. Having filled successively the offices of quæstor, ædile, and prætor, he was appointed to the command of a legion in Germany, and afterward to the government of Belgic Gaul. Here he showed much energy in repressing an insurrection of the Chauci, and for this service he was made consul. He also distinguished himself against the Catti, was governor of Dalmatia and afterward of Lower Germany, and then took charge of the commissariat in Italy. After this he was governor of Bithynia in Asia Minor, was again consul in 179, and having filled the office of proconsul of Africa, returned to Rome, where he was made commander of the city guards. After the assassination of Pertinax, the prætorian guards offered the imperial throne to him who would pay the highest price; and after a brisk bidding against Sulpicianus, prefect of the city, Didius obtained it. The senate was obedient to the will of the unruly soldiery, and Didius was acknowledged emperor. But whenever he appeared in public he was received with cries of "Robber and parricide." Moreover, he was not recognized as emperor by Septimius Severus, who held command of three legions in Illyria, by Clodius Albinus, nor by Pescennius Niger, who held like commands in Britain and Syria respective-

ly. Severus, having been proclaimed emperor by his troops, marched upon Rome, and was recognized by the senate. Deserted by his adherents, Didius was murdered in his palace by a common soldier, having reigned a little more than two months; and Septimius Severus established himself in his place.

**DIDO**, or **Elissa**, a legendary Phœnician princess and founder of Carthage, daughter of Mutgo, Belus, or Agenor, king of Tyre. According to Justin, she was the wife of her uncle Acerbas (the Sichæus of Virgil), priest of Hercules, who was murdered for his wealth by Pygmalion, the son and successor of Mutgo. Dido dissembled her sorrow, and with a number of disaffected Tyrian nobles escaped from her native country, bearing the treasures of her murdered husband. The party first landed at the island of Cyprus, whence they carried off by force 80 maidens, and then pursuing their journey embarked on the coast of Africa, purchased as much land as might be covered with the hide of a bull, and by cutting the hide into thin strips enclosed a large tract of country, on which the city of Carthage soon began to rise. (See **CARTHAGE**.) Their prosperity excited the jealousy of a neighboring chief, Hiarbas, who demanded the hand of Dido in marriage, and threatened war in case of refusal. The queen asked three months for consideration, at the end of which time she mounted upon a funeral pile and plunged a sword into her breast. Virgil represents her as killing herself on being abandoned by Æneas.

**DIDOT**, the name of a French family of printers. The firm, now existing under the name of Firmin Didot frères, was established in 1713 by FRANÇOIS DIDOT, who made himself known by several important publications, and gained such popularity as to be appointed syndic of the booksellers' corporation. His two sons, FRANÇOIS AMBROISE (1730-1804) and PIERRE FRANÇOIS (1732-95), increased the business, and paid especial attention to the printing department. While the latter established paper mills at Essonne, near Paris, the former materially improved the casting of types, the best specimens of which ever seen in France were from his foundery; and his standard editions were admired for their correctness and beauty. The *Collection d'Artois* (64 vols. 18mo), and the *Collection des classiques français*, printed at once in 4to, 8vo, and 18mo, by order of Louis XVI., are still highly valued. Among the sons of Pierre, HENRI, a type founder, is known for the microscopical types with which he printed some little volumes which are esteemed as gems of their kind; and SAINT-LÉGER engaged in the manufacture of paper. The sons of François Ambroise, PIERRE (1760-1853) and FIRMIN (1764-1836), who succeeded their father at the beginning of the revolution, added to the good name of the firm by publishing magnificent folio editions of classic French and Latin writers, known as *éditions du Louvre*. Firmin also aimed to furnish the general reader

with cheap and correct editions. He invented, or more correctly revived the stereotype process, which he brought at once to comparative perfection. He translated Virgil's "Bucolics" and Theocritus's "Idyls." He was elected in 1827 to the chamber of deputies. His sons, AMBROISE FIRMIN, born in 1790, and HYACINTHE, born in 1794, succeeded him in the management of the firm. Among their notable publications are: *Monuments de l'Égypte et de la Nubie*, by Champollion the younger; *Voyage de Jacquemont dans l'Inde*; *Expédition scientifique des Français en Morée*; the *Thesaurus Lingue Græcæ* of Henry Stephens, with annotations and additions by the best French and German scholars; a complete *Bibliothèque des auteurs grecs*, a very cheap and correct edition of the Greek writers, with copious notes and Latin translations. Their editions of the French classics are numerous and valuable; while their extensive popular publications, such as *L'Univers pittoresque*, *L'Encyclopédie moderne*, and *La nouvelle biographie générale* (completed in 1866), are remarkable for cheapness and general accuracy. The two heads of the firm are now aided by their sons ALFRED (born in 1828) and PAUL (born in 1826).

**DIDRON, Adolphe Napoléon**, a French archaeologist, born in Hautevillers, department of Marne, March 13, 1806, died in Paris, Nov. 13, 1867. He travelled on foot through Normandy, examining all the remarkable mediæval monuments. In 1835 he was appointed by Guizot secretary of the historical committee of arts and monuments, and wrote the four volumes of elaborate reports issued by that committee. In 1838 he delivered in the royal library a course of lectures on Christian iconography, after which he made a journey to Greece to compare the art of the Greek church with that of the West, and to obtain access to mediæval manuscripts. On his return to Paris in 1840 he delivered another course of lectures, and in 1845 founded there an archaeological publishing house, and a manufactory of painted glass. He established in 1844, and edited until 1866, the *Annales archéologiques*, devoted particularly to the archaeology of the middle ages, in preparing which he was assisted by the principal archaeologists, architects, designers, and engravers of Europe. His most important publication is the *Manuel d'iconographie chrétienne grecque et latine* (1845), of which an English translation was published in 1851.

**DIDYMIUM** (Gr. *δίδυμος*, twin), a metal discovered in 1841 by Mosander in the mineral cerite, and named for its resemblance to the metal lanthanum, which occurs in the same mineral, and for the persistence with which its salts remain combined with those of this metal. The rose color of the salts of lanthanum is probably due to the presence of didymium. But neither of the two metals, nor the cerium with which they occur, possesses any special interest, and the complete quantitative separation of the metals is even yet attended with great difficulty.

**DIDYMUS**, an Alexandrian grammarian and critic, born about 64 B. C. He was noted for his industry and the copiousness of his writings, in consequence of which he received the nicknames of *Χαλκέντερος*, or brazen-bowelled, and *Βιβλιολάθας*, or forgetter of books. The number of his works is stated by Athenæus at 3,500, and by Seneca at 4,000.

**DIEBITSCH, Hans Karl Friedrich Anton**, a Russian general, born in Silesia, May 13, 1785, died near Pultusk, Poland, June 10, 1831. His father, a Prussian and afterward a Russian officer, sent him in 1797 to the house of cadets in Berlin, but made him enter the ranks of the Russian imperial guard in 1801. He fought in the battles of Austerlitz, Eylau, and Friedland, was made captain, and devoted himself to the study of military science during the five years of peace which followed the treaty of Tilsit. He served under Wittgenstein during the invasion of the French in 1812, and persuaded the Prussian general York to capitulate. As chief of Wittgenstein's staff in 1813 he distinguished himself at Lützen, and was then attached as quartermaster general to the corps of Barclay de Tolly in Silesia. At Leipsic he was made by the emperor Alexander lieutenant general on the battle field. In the campaign of 1814, when Schwarzenberg advised the retreat of the allied armies, Diebitsch decided for the march on Paris, which terminated the war. In 1815 he married a niece of Barclay de Tolly. Being made chief of the staff of the army, he accompanied Alexander through the south of Russia, and was present at his death at Taganrog in 1825. At St. Petersburg he distinguished himself during the outbreak of Dec. 25 by intrepidity, prudence, and humanity. The new emperor, Nicholas, rewarded his services with the title of baron, and afterward with that of count. In the war of 1828-'9 against Turkey he took Varna, and by marching across the Balkan forced the Porte to make the peace of Adrianople, and received the name of Zabalkanskoi (Transbalkanian, that is, crosser of the Balkan). On the outbreak of the revolution in Warsaw, Nov. 29, 1830, he was appointed commander-in-chief of the army and governor of the provinces adjoining Poland. He crossed the Polish frontier Jan. 25, 1831, but the engagements at Wisniew and Stoczek, Feb. 11, at Dobre on the 18th, at Grochów and Wawer on the 19th, and still more the battles fought about the end of March in the vicinity of Praga, proved that fortune had left his banners. Without profiting by the favorable issue of the battles of Nur, Lomza, and Ostrolenka (May 15-26), he removed his camp to Kleczewo, where he suddenly died of cholera.

**DIEDENHOFEN** (Fr. *Thionville*), a fortified town of Germany, in Lorraine, situated on the Moselle, and on the railway from Metz to Luxemburg, about 15 m. N. of Metz; pop. in 1871, 7,155. It has a gymnasium, a botanic garden, and manufactories of hosiery, woollen

cloths, candles, leather, liqueurs, and spirits. The Carolingian kings of France frequently resided here; subsequently the town belonged in succession to the counts of Luxemburg, to Burgundy, Austria, and Spain. In 1643, when it surrendered to the prince of Condé, it was annexed to France. In 1870 it suffered considerably from bombardment by the German troops, to whom the French garrison, consisting of 120 officers and 4,000 men, surrendered on Nov. 24. By the peace of May 10, 1871, it was ceded to Germany. The town is well built, and the fortifications constitute a fortress of the third class.

**DIEFENBACH, Lorenz**, a German philologist and author, born at Ostheim, Hesse-Darmstadt, July 29, 1806. He was educated at the university of Giessen, and became a clergyman, and in 1845 one of the founders of the German Catholic church in Offenbach, which city he represented in 1848 in the parliament at Frankfurt, and where in 1865 he was appointed second director of the library. He was a voluminous author, and published poems, novels, and various productions in light literature, as well as learned treatises. His principal works are: *Celtica* (3 vols., Stuttgart, 1839-'42); *Vergleichendes Wörterbuch der gothischen Sprache* (2 vols., Frankfurt, 1846-'51); *Pragmatische deutsche Sprachlehre* (Stuttgart, 1847; 2d ed., 1854); *Glossarium Latino-Germanicum Mediæ et Infimæ Ætatis* (Frankfort, 1857; 2d ed., 1867); and *Origines Europææ* (1861). The *Glossarium* is a supplement to Du Cange's.

**DIEFENBACH, Johann Friedrich**, a German surgeon, born in Königsberg, Feb. 1, 1792, died in Berlin, Nov. 11, 1847. He was the son of a professor of theology, and at first devoted himself to that study, but joined in the war against Napoleon, serving as a volunteer

in a company of Mecklenburg troops from 1813 to 1815. He afterward resumed his theological studies, which he exchanged for the pursuit of medicine. Having taken his medical degree at Würzburg in 1822, he established himself at Berlin, where in 1830 he was appointed head surgeon of one of the hospitals, two years after professor in the university, and in 1840 director of clinical surgery. He was distinguished for his dexterity in the use of the scalpel, for the success of his operations in the formation of artificial noses, cheeks, lips, &c., and for the cures which he effected in cases of squinting and stammering. He also made great improvements in surgical instruments. Among his works are: "Operative Surgery," which has been translated into several different languages; "Surgical Experiences, especially with regard to the Restoration of Portions of the Human Body which have been destroyed;" "The Cure of Stammering by a new Surgical Operation;" and "On the Cutting of the Sinews and Muscles."

**DIEPPE**, a seaport town of France, department of Seine-Inférieure (Normandy), on the English channel, at the mouth of the Arques, 52 m. E. N. E. of Havre, and 93 m. N. N. W. of Paris; pop. in 1866, 19,946. It extends a mile along the coast, has wide and regular streets, and its houses, mostly of one style, are of brick, two stories high, with balconies toward the street. The finest hotels and residences are near the harbor, on the main street, which runs parallel with the sea the whole length of the town. The most remarkable public edifices are the churches of St. Remi and St. Jacques. The latter, a large Gothic structure, commenced in the 13th century, and not completed till the 15th, is built entirely of stone brought from England. The former



Castle of Dieppe.



is in the mixed Gothic-Saracenic style. There is a commercial court, a chamber of commerce, and a school of navigation. Dieppe is well supplied with water by an aqueduct 3 m. long, cut in the solid rock, and has 68 public and numerous private fountains. The port, enclosed by two jetties, is spacious and secure, with a basin of sufficient depth for vessels of 1,200 tons, but the entrance is difficult. It has two suburbs, La Barre and Le Pollet, and is protected by an old castle and by some batteries. Its manufactories of ivory are famous; and there are also sugar refineries, rope walks, paper mills, and ship yards. The manufacture of tobacco employs 1,200 hands. Fishing, however, occupies the attention of the greater portion of the inhabitants; from two oyster beds near the town about 12,000,000 oysters are annually sent to Paris. Dieppe is connected with Rouen, Paris, and Havre by rail, and by steamer with Newhaven, near Brighton, England. Its sea baths, with its pure air and picturesque situation, have made it the chief watering place of France. The principal bathing establishment combines reception rooms, ball, concert, and billiard rooms, and literary, social, and convivial saloons. In the early part of this century it became, under the patronage of the duchess de Berry, the rendezvous during the summer of the noblest families of France. Dieppe was founded in the 10th century, and in less than four centuries it had become the rival of Rouen. It was bombarded by the English and Dutch in 1694. It was the first maritime town of France occupied by the Germans in the war of 1870.

**DIESKAU, Ludwig August**, a German soldier in the French service, born in Saxony in 1701, died near Paris, Sept. 8, 1767. He was adjutant of Marshal Saxe, in whose interest he visited St. Petersburg in 1741. He accompanied him in the campaigns against the Netherlands, and became in 1748 brigadier general of infantry, and commander of Brest. In 1755 he was sent to Canada, at the head of French troops, to assist in the campaign against the English. With 600 Indians, as many Canadians, and 200 regular troops, he ascended Lake Champlain with the design of attacking Fort Edward. On Sept. 8 he defeated a detachment under Col. Williams, which had been sent against him, and pursued them to the British camp. The savages, however, halted just without the intrenchments, the Canadians became alarmed, and the regulars perished before the fire of New England marksmen. Dieskau, thrice wounded, refused to retire from the field, and seated himself on the stump of a tree, exposed to the shower of bullets. He was severely wounded by a random shot, and was kept a prisoner till 1763, when he returned to France, receiving a pension.

**DIESTERWEG, Friedrich Adolf Wilhelm**, a German teacher and writer on education, born at Siegen, Oct. 29, 1790, died in Berlin, July 7, 1866. He studied at the academy of Herborn

and the university of Tübingen, and subsequently taught in various normal and Latin schools till 1832, when he was appointed director of the seminary for teachers of city schools in Berlin. He retired in 1850. He is the author of numerous text books on mathematics and geography, and of several manuals for teachers, which have passed through many editions. He advocated the theories of Rousseau, Pestalozzi, and modern liberalism in general, and was constantly engaged in polemics on school reform, which he published in his *Pädagogisches Jahrbuch* (Berlin, 1851-'65), and other periodicals. His biography has been written by Langenberg (3 vols., Berlin, 1867-'8).

**DIEST**, a town and fortress of Belgium, in the province of South Brabant, situated on the Demer, and on the railway from Antwerp to Liège, 32 m. N. E. of Brussels; pop. in 1866, 7,561. It has a college, several breweries, and flourishing manufactories of hosiery and woollens. Its only remarkable building is the church of St. Sulpicius. Its beer is celebrated, and large quantities are exported. Marlborough captured the town in 1705, but in the same year the French retook it and dismantled the fortifications.

**DIET** (Fr. *diète*), a term applied to several political bodies of mediæval and modern Europe, corresponding to the parliament in Great Britain, the cortes in Spain and Portugal, the states general, national assembly, and chambers in the history of France, and the congress in the United States. The derivation of the term from the Latin *dies*, day, as meaning a day fixed for the national deliberations on public affairs, is proved by the corresponding words in German (*Reichstag*), Dutch (*Rijksdag*), Swedish (*Riksdag*), and Danish (*Rigsdag*), all of which mean day of the empire; and by the similar Swiss term for the Helvetic diet (*Tagsatzung*). It is used by English and French historians of the state assemblies of the German empire and confederation, Poland, Hungary, Sweden, Switzerland, and some other countries, to which the Germans apply the distinctive appellations of *Reichstag*, *Landtag*, *Landstände*, *Bundestag*, *Tagsatzung*, &c. The diet of the German empire, which must not be confounded with the popular assemblies of the Germanic nations in the Carolingian times, or with the assembly (*Bundestag*) of the German confederation as established by the congress of Vienna, had its rise after the dissolution of the Frankish empire, and was slowly developed under the successive German houses, undergoing material changes, particularly in the reigns of the emperor Charles IV. in the 14th century, Frederick III. in the 15th, and Charles V. in the 16th, until it received its ultimate modifications by the treaty of Westphalia in 1648, and the session of Ratisbon in 1663. From this date down to the dissolution of the empire in 1806, Ratisbon became its permanent seat, while in previous times the emperor had the privilege of choosing the place of its ses-

sions. The emperor, who formerly appeared in person, was now represented by a principal commissary, and all members of the empire by plenipotentiaries or agents. The diet consisted of three divisions, the so-called colleges of electors, princes, and imperial cities. The elector of Mentz, the archchancellor of the empire, presided in the electoral college, the archbishop of Salzburg and the archduke of Austria alternately in the college of princes, and the city where the session was held in that of the cities. The electors and cities had individual votes, as well as the chief members of the college of princes, while the imperial counts and imperial prelates, who belonged to the latter, had only collective votes by benches, of which there were four of counts and two of prelates. Resolutions were passed by majority, except in religious matters and those concerning individual members of the empire alone. But the concurrence of all the three colleges and the ratification of the emperor were required to establish a decree of the empire (*Reichsschluss*). Concurrence in case of difference of opinion was obtained by reconsideration and conference. The emperor had the right of rejection of the whole or a part of the bill, but not of modification. The collection of resolutions passed and sanctioned by a diet was termed imperial recess (*Reichsabschied*). The diet framed the laws of the empire, abolished and explained them, declared war and made peace, received and sent envoys, and concluded treaties. Imperial wars were proposed by the emperor, decided upon by majority, and carried on by the contingents of both the majority and the minority. The administration of the German confederation (*Bund*), which lasted, with some modifications, from 1815 to 1866, was vested in a diet (*Bundestag* or *Bundesversammlung*), the members of which were appointed by the various governments, Austria being the leading power, though the leadership came to be disputed by Prussia. (See GERMANY.)—The Polish diet (*sejm*) dates principally from the reign of Ladislas the Short, who in 1331 assembled all the nobles of his kingdom. Its form was established by law under Casimir IV. In the last period of independent Poland it was convened regularly every two years, for a session of no more than six weeks, twice successively in Warsaw and the third time at Grodno, in Lithuania. It consisted of a senate and a chamber of deputies (*poset*, plur. *postowie*). The latter were elected in previous municipal or district assemblies (*sejmik*, little diet). After the verification of their powers, the diet elected their president or marshal (*marszałek*). The initiation of measures was a royal prerogative, the sovereign furnishing a list of subjects to be discussed during the session. In case of urgency the king could convoke an extraordinary diet to remain in session only two weeks. The most remarkable feature of the Polish diet was the so-called *liberum veto*, or the right of each

member to prevent the enactment of a law or measure by individual opposition (*nie pozwalam*, I do not allow, or *veto*). This extreme of liberty, unknown in the history of any other nation, was remedied in part by confederations formed by the majority for the execution of its designs, and by timely application of violence, which silenced treacherous or bribed opponents; but it also led to fatal distractions, scenes of bloodshed, the permanence of factions, and ultimately, with other causes, to the fall of Poland. The diet of election was preceded by a diet of convocation, the archbishop of Gnesen, the primate of the state, having announced the vacancy of the throne. Hereupon all nobles appeared personally, assembling on the plain of Wola, near Warsaw, the senate in a shed (*szopa*), the common nobles in the *kolo* (circle). A diet of coronation, and, if that of election had been stormy, another of pacification, followed.—The diet of Hungary (*diéta*, or *országgyűlés*), formerly convened at various places, was from the time of the Turkish invasion held at Presburg. It consisted of two houses, the upper, or table of magnates, and the lower, or table of deputies. In the latter, previous to the law of 1848, only the representatives of the nobles in the counties had a decisive personal vote. During the revolutionary period of 1848-'9 the diet was held successively at Pesth, Debreczin, and Szegedin. Since 1861 it has its seat in Pesth. (See HUNGARY.)

**DIETERICI.** I. Karl Friedrich Wilhelm, a German statistician, born in Berlin, Aug. 23, 1790, died there, July 29, 1859. He began his university studies in Königsberg, devoting particular attention to mathematics, and continued them in Berlin, where in 1812 he became tutor in the family of Klewitz, afterward minister of state. As engineer in the army of Blücher, he made the campaigns of 1813, 1814, and 1815; and in 1820 he was employed in the ministry of public instruction under Altenstein. In 1834 he was appointed professor of political science in the university of Berlin, and in 1844 succeeded Hoffmann in the direction of the statistical bureau. His writings relate mainly to subjects of political economy. The most important are, *Uebersicht der wichtigsten Gegenstände des Verkehrs und Verbrauchs im preussischen Staate und im deutschen Zollverbande* (1838-'53), and *Der Volkwohlstand im preussischen Staate*. He left unfinished an important work, *Handbuch der Statistik des preussischen Staats*, which was completed by his son Karl in 1861. II. Friedrich, a German orientalist, son of the preceding, born in Berlin, July 6, 1821. He studied theology at Halle and Berlin, and oriental languages at Leipsic, and afterward in the East. In 1850 he became professor of Arabic literature in the university of Berlin, having been for some time dragoman of the Prussian embassy at Constantinople. He has published *Reisebilder aus dem Morgenlande* (1853), a translation of

the Arabic grammar entitled *Alfayah* (1854), *Die propädeutischen Studien der Araber* (1851), *Chrestomathie ottomane* (1865), and other works.

**DIETETICS.** For his complete nutrition man must have in his food the albuminoid materials of which his tissues are mainly composed, the iron and the salts contained in those tissues and in the blood, and fatty matter, or some substance which can readily be converted into fat, which enters into the composition of his body, and which serves to maintain the animal heat. (See **ABSTINENCE, ALIMENT, ANIMAL HEAT, and DIGESTION.**) But food must not only contain all the principles necessary to nutrition, it must likewise be digestible and assimilable; it must be capable of being disintegrated and dissolved in the alimentary canal, so that it may be absorbed, and finally converted into blood from which the waste of the tissues may be supplied. An article may be highly nutritious, yet exceedingly indigestible; or it may be easily digestible, and afford little nutriment. While certain articles and classes of articles are in general more digestible, there is no rule of invariable application. There are differences in kind as well as in degree in the digestive powers of different individuals; and what will offend the stomach of one man, another will digest with ease. But aside from individual peculiarities, there are more general causes of difference. 1. Habit has great influence. What men have been accustomed to, they digest with greater facility. An American or Englishman visiting the continent of Europe is frequently attacked with diarrhoea, from an unaccustomed diet, which is in itself equally wholesome with his own. During the revolutionary war numbers of the troops from the southern states while on duty at the north became ill, and their health was only restored by an allowance of fat bacon. The ill-fed Irishman, on enlisting into the British army, frequently is affected with what is termed a "meat fever;" his new diet is so much superior to what he was accustomed to, that his organs do not readily adapt themselves to the change. 2. Circumstances have a great influence on the digestibility of food. A diet suited to Labrador would be oppressive and injurious in the West Indies. The season, amount of clothing, exposure, and exercise have an influence on the digestive capacity as well as on the requirements of the system. 3. The digestibility of food is much influenced by our liking for it; within certain limits, what we are fond of agrees with us, and what we dislike is not apt to digest well. The high flavor which excites the appetite of the epicure provokes nausea in a less cultivated stomach. Still, despite the various sources of diversity, some articles are for the majority of men of comparatively easy digestion, while others are assimilated with greater difficulty.—Food is commonly classed as animal or vegetable. Animal food may be

subdivided into the flesh of mammals, birds, fishes, reptiles, crustaceans, and mollusks. The flesh of the mammals, and indeed of the birds and fishes used for food, differs very little in chemical composition. The fibrine, albumen, and gelatine of which chiefly they are made up, may be considered as chemically identical, from whatever animal they may be derived. The fats differ in the relative proportions, and sometimes in the character, of the fatty acids which enter into their composition; the saline matters, varying in their proportions, are mainly of the same character; while the immense variety of flavors by which they are distinguished depend upon principles existing in exceedingly minute proportions, and for the most part soluble in water. The difference in meats arises from the varying proportions of fibrine, gelatine, and fat, and from variations in mechanical texture; and to these circumstances is due their difference in digestibility. Whatever renders the animal fibre harder, makes the meat less digestible; whatever renders it more delicate and tender, more easily separated and disintegrated, makes it more easily soluble in the juices of the stomach. Provided an animal has reached maturity, the tenderness of its meat is increased by youth, by its not having been worked, by its being in good condition, the muscular fibres interpenetrated and separated by minute proportions of fatty tissue. Keeping tends very much to improve the tenderness of meat. Few animals are fit to be eaten the day they are killed; but when kept, long before the slightest taint can be detected, a change takes place that renders the fibres more easily separated and disintegrated, more readily broken down and comminuted during mastication, and more quickly reduced and assimilated by the stomach. Of the different meats, venison that has been well kept is, in its season, perhaps the most tender and digestible. Dr. Beaumont found that in St. Martin a meal of broiled venison steak was completely digested and removed from the stomach in an hour and a half, a shorter time than was required by any other meat. Wether mutton of a proper age, that has hung for a sufficient length of time, is scarcely inferior in digestibility to venison. Beef ranks next to mutton. Lamb and veal are less digestible than mutton or beef, and veal is less readily digested than lamb. Of all the meats in ordinary use, pork is most refractory to the gastric juices; and, contrary to what holds with regard to beef and mutton, the sucking pig is more digestible than pork. The fat of meats generally, and all varieties of fatty matters, are difficult of assimilation; they are particularly offensive to weak stomachs, sometimes appearing to form an oily pellicle, which, floating on the partially chymified mass, becomes rancid and occasions distressing heartburn and nausea, or causes eructations of acrid matter which leave a peculiarly disagreeable taste upon the palate. The mode of dressing

meat has a great influence upon its digestibility; that which agrees best with the majority of stomachs is broiling. The fire should be brisk, so that the albumen on the surface of the meat may be rapidly coagulated; this preserves the juices, and it is rendered at once more savory and more tender. The same rule applies to boiling and roasting. When the meat is to be cooked, if boiled, it should be at once plunged into boiling water; while if soup is to be made, the meat should be put into cold water and the temperature slowly raised, thus extracting its nutritious fluids to the greatest possible extent. Of all methods of cooking, frying is the most objectionable; not only is the meat rendered harder than when boiled, and thus more indigestible, but it becomes imbued with boiling fat, and is thus rendered still more refractory to the gastric juice. Rich stews are objectionable on the same account. By the action of salt on muscular flesh, the juices of the meat are abstracted; in this manner not only is its nutritive value impaired, but it is rendered harder and drier and consequently more indigestible; the longer the flesh is exposed to the action of salt, the harder and drier it becomes. Perhaps all fats form an exception to the fact that meat is rendered more indigestible by salting; they have little water to lose, and their texture consequently cannot become consolidated; fat pork is even rendered more digestible by salting. St. Martin, according to Dr. Beaumont's observations, digested recently salted pork when raw or broiled in from 3 to 3½ hours; the same article fried occupied him 4½ hours for its reduction; while fresh pork, fat and lean, roasted, required 5½ hours. On the other hand, boiled fresh beef with a little salt was digested in 2½ hours, while old salted beef required 4½ hours when dressed in the same manner. All empyreumatic substances impair digestion by interfering with the action of the pepsin, which is the principal solvent agent of the gastric juice. In this manner smoking impairs the digestibility of meat; few things are more difficult of management by a feeble stomach than old and well smoked beef. St. Martin found fowls, roasted or boiled, of slower digestion than beef; ducks and geese, as might be supposed from the amount of fat they contain, are assimilated with difficulty. There is, however, so much variation in this respect in different individuals, that the absolute digestibility of an article of food can hardly be deduced from experiments on a single person. Fish furnishes an abundant and digestible variety of food. The dry, white sorts, cod, haddock, bass, &c., are the most digestible; while the richer kinds, salmon, shad, mackerel, eels, &c., are less apt to agree with the stomach. St. Martin digested boiled or fried salmon trout in 1½ hour, boiled dried cod in 2 hours, fried catfish in 3 hours 20 minutes, and boiled pickled salmon in 4 hours. Milk, the only food during the earlier months of infancy, con-

tains from 12 to 13 per cent. of solid matter, about one half of what is contained in flesh; it is poorer in nitrogenous and richer in carbonaceous food; its ash furnishes but 0.47 per cent. of iron, while those of flesh and wheat flour yield 1 per cent. It is not digested so quickly as would be supposed, and in this respect boiled has the advantage of unboiled milk; the one took St. Martin 2 hours, the other 2½, to convert into chyme. Milk disagrees with many persons; this is often connected with the readiness with which it undergoes change when exposed to the atmosphere, and this change commences long before it can be recognized by the taste. Milk just drawn from the cow agrees perfectly with some persons who are unable to take it a few hours later. When cows are kept in an impure and confined atmosphere and badly fed, it has been conclusively shown that their milk produces disturbance of the digestive organs and diarrhoea in infants who are fed upon it. The casein of milk, coagulated, generally mixed with more or less butter, and pressed so as to free it from the whey, constitutes cheese. Its richness varies with the quantity of butter it contains; some varieties, Stilton for instance, are made from milk to which an additional quantity of cream has been added. Salt is used to preserve it, and some kinds, as Dutch cheese, are very highly salted. When cheese is kept for a length of time, it undergoes a number of changes, partly dependent on the liberation of the volatile fatty acids existing in the butter, partly, in the richer varieties, on the commencement of putrefactive fermentation. The firm, close texture of cheese renders it always hard of digestion, and the rich and strong-smelling varieties are particularly to be avoided by delicate stomachs. Fresh sweet butter is, perhaps, the most wholesome and digestible of fatty matters; by heating or rancidity its digestibility is greatly impaired.—Of farinaceous articles, light well made wheaten bread, from 12 to 24 hours old, is the most generally digestible; warm bread is indigestible, because it forms a tough mass not readily penetrated by the saliva and rebellious to the gastric juices. Unleavened bread, maccaroni, and vermicelli are wholesome, and agree well with the stomach; on the other hand, flour combined with fatty matter, whether in the form of pastry, cake, or pudding, is more or less indigestible, according to its texture and richness. Next to wheat flour, rye affords the best and most wholesome bread. In various countries oatmeal, barley, and maize are used as substitutes for wheat; they form kinds of bread wholesome enough for those habituated to their use, but apt to disagree with strangers. In tropical countries rice to a great extent takes the place of the other cereals, and perhaps a larger population mainly subsist on it than on any other single article of food. It affords very little of plastic or blood-making material, and hence when taken alone is con-

sumed in enormous quantity; as an adjunct it forms an unstimulating and digestible article of food. The leguminous seeds, peas and beans, afford a nutriment rich in plastic matter, but hard of digestion and predisposing to flatulence. The popular prejudice that sugar produces caries of the teeth has no good foundation. Closely allied to sugar are the various forms of fecula, arrowroot, tapioca, sago, potato starch, &c. They consist of minute granules composed of concentric layers, and termed the starch grains. These grains must be softened and hydrated by boiling, roasting, or panification before the starch is fit for use. It then forms an unstimulating and readily digestible ingredient of the food. Vegetables constitute an important part of our diet. With few exceptions their nutritive value is low; they consist largely of water holding organic salts in solution, of starch granules, of small quantities of albuminous matter, and of cellulose and epidermis. The cellulose, though possessing a chemical constitution identical with that of starch, when at all firm, resists the action of the gastric juice, and passes unchanged through the intestinal canal. They are valuable on account of their large quantities of organic salts, of the bulk which they give to the food, and of their stimulating effect upon the peristaltic action of the intestines. These latter qualities make them disagree where the digestive organs are feeble and irritable. They are digestible in proportion to their tenderness and the readiness with which they can be broken up into a pulp. The potato is one of the most valuable of the nutritious vegetables. St. Martin found potatoes roasted and baked disposed of more readily than when boiled, the one taking  $2\frac{1}{2}$  hours to be converted into chyme, the other an hour longer. The same rule applies to fruits as to vegetables; they are digestible just in proportion to the readiness with which they can be completely reduced to a pulp. Ripe strawberries, peaches, oranges, and grapes rarely disagree, while cherries, apples, pears, &c., are more indigestible; roasting improves the digestibility of apples and of most of the more solid fruits.

**DIETZ, Fedor**, a German painter, born at Neuenstetten, Baden, in 1813, died near Dijon, in France, Dec. 18, 1870. He was president of the art academy at Carlsruhe, and was famous for his battle pieces. His most celebrated pictures are the "Death of Gustavus Adolphus and Pappenheim at Lützen," the "Storming of Belgrade by Max Emanuel," and "Queen Eleonore of Sweden at the Grave of Gustavus Adolphus." The two last named are in the Munich athenæum. He died while presiding over the German sanitary organization in France.

**DIEZ, Friedrich Christian**, a German philologist, born in Giessen, March 15, 1794. He studied philology at Giessen and Göttingen, and in 1823 became professor at Bonn. He is the author of *Altspanische Romanzen* (Berlin, 1821); *Beiträge zur Kenntniss der romani-*

*schen Poesie* (Berlin, 1825), republished in French under the title of *Essai sur les cours d'amour* (Paris, 1842); *Die Poesie der Troubadours* (1826); and *Leben und Wirken der Troubadours* (1829). Though these works were rapidly translated into French and English, he owes his reputation mainly to his *Grammatik der romanischen Sprachen* (3 vols., Bonn, 1836-'42), and *Etymologisches Wörterbuch der romanischen Sprachen* (Bonn, 1853), translated into English by T. C. Donkin (London, 1864).

**DIFFERENTIAL CALCULUS.** See CALCULUS.

**DIFFRACTION OF LIGHT.** See LIGHT.

**DIGAMMA** (double gamma; so called from its form, F, resembling two gammas, Γ), the sixth letter in the ancient alphabet of the Greeks, corresponding to the Hebrew ך and the Latin *f*; and probably equivalent in sound to the English *v*. It continued latest in the Æolic dialect, but early became obsolete in the Attic alphabet, and subsequently in the Greek language; though its original existence is indicated by the fact that the fifth letter (ε) is the numerical symbol for 5, but the next letter (ζ) for 7. It does not appear in the Homeric poems as usually published, though they were composed when it was in use; but its force remained in the metre after its form had disappeared, and its latent existence at the beginning of many words and syllables apparently commencing with a vowel made preceding short syllables, if ending with a consonant, long by position, or, if ending with a vowel, prevented a hiatus. In words of the Latin language etymologically connected with Greek words which were originally written with the digamma, it is represented by *v*, thus: *ἑσπερος* (ΕΣΠΗΡΟΣ), *vesperus*; *ὄων*, (ΩΦΩΝ), *ovum*.

**DIGBY**, a W. S. W. county of Nova Scotia, bordering on the Atlantic; area, about 1,300 sq. m.; pop. in 1871, 17,037. Long island and Digby neck, a long headland, enclose St. Mary's bay on the N. W. The surface is diversified with numerous mountains, valleys, and lakes, the last named giving rise to several rivers. Copper and silver ores are found. Capital, Digby.

**DIGBY. I.** Sir **Keelm**, an English philosopher, born at Gothurst, Buckinghamshire, in 1603, died in London, June 11, 1665. He was the son of Sir Everard Digby, who was executed in 1606 for complicity in the gunpowder plot. He was educated in the Protestant faith, and showed early tokens of talent. In 1621, having finished his education at Oxford, he visited the continent, where he travelled for about two years. After his return he was made gentleman of the bedchamber by Charles I., and held several offices. In 1628 he sailed with a squadron fitted out at his own expense, to fight the Algerines and the Venetians, with whom the English had quarrelled, and gained much credit by his courage and success. In 1636, while in France, he became a convert to Catholicism. He returned to England in 1638, sided

with the king in the dissensions of the time, and was imprisoned by order of parliament. During his confinement he wrote several treatises. He was released in 1643 at the intercession of the queen of France, and retired to that country, where he was received with great honor. From this time till 1661 he lived mostly on the continent, and especially in France, employing himself with literary and scientific labors. Having returned to England, he enjoyed the favor of Charles II., and continued his philosophical studies until his death. He married a daughter of Sir Edward Stanley, and his curious experiments to preserve her extraordinary beauty gave him quite as much celebrity as his books. His principal works are: "A Conference with a Lady about the choice of a Religion" (Paris, 1638); "Observations on Religio Medici" (London, 1643); a "Treatise on the Nature of Bodies" and "Treatise on the Soul, proving its Immortality" (Paris, 1644); a "Treatise of adhering to God" (London, 1654); "Of the Cure of Wounds by the Powder of Sympathy" (London, 1658); and "Private Memoirs of Sir Kenelm Digby, &c., written by Himself," first published in 1827.

**II. Kenelm Henry,** an English author, descended from an uncle of the preceding, born in 1800. His father, the Rev. William Digby, was dean of Clonfert, Ireland. He graduated at Trinity college, Cambridge, in 1823, embraced soon after the Roman Catholic faith, studied scholastic theology and the literature and antiquities of the middle ages, and devoted himself exclusively to the illustration of mediæval times and manners. In 1826-7 he published "The Broad Stone of Honor: on the Origin, Spirit, and Institutions of Christian Chivalry." Pursuing with unflagging industry his archæological studies in the various countries of continental Europe, the fruits of his research appeared anonymously from 1844 to 1847, under the title of "Mores Catholici, or Ages of Faith" (3 vols. royal 8vo, London). In 1851 appeared "Comptum, or the Meeting of the Ways at the Catholic Church;" in 1856, "Lover's Seat: Kathemérina" (2 vols. 12mo); in 1858, "Children's Bower, or What You Like" (2 vols. 12mo); in 1860, "Evenings on the Thames" (2 vols. 12mo; 2d ed., 1864); and in 1861, "The Chapel of St. John, or a Life of Faith," being a memorial to his deceased wife.

**DIGESTION** (Lat. *digerere*, to dissolve or con-coct), the liquefaction and preparation of the food in the alimentary canal. The organs by which this function is performed in the higher animals are the mouth, pharynx, œsophagus, stomach, and intestines, with their accessory salivary glands, pancreas, liver, and mucous follicles. The first act to which food is subjected is the mechanical division by the teeth. This process is important in order to reduce the food from a crude mass to a finely divided pasty condition, in which it is more readily and thoroughly affected by the digestive se-

cretions of the alimentary canal. While some of the nutritive matters are dissolved in and absorbed directly from the stomach, others require further preparation, and are taken up by the vessels and absorbents of the intestines; by the time that the residue arrives in the cæcum, almost all the alimentary matter has been extracted, and the insoluble portions with the excess of biliary and mucous secretions are voided at the anal termination of the canal. The digestive process can hardly be separated from absorption, which takes up the nutritive materials, and assimilation, which converts them into a fluid resembling blood, poured into the circulation near the heart. Though inorganic substances are necessary for the support of the body, the organic alone are generally considered as food and as subjects for the digestive process. Organic substances used as food may be conveniently arranged under three heads: 1, the saccharine group, embracing substances composed of oxygen, hydrogen, and carbon, resembling sugar in composition, and readily convertible into it; such are starch, gum, woody fibre, and the cellulose of plants; 2, the oleaginous group, with a great preponderance of hydrogen and carbon, small proportion of oxygen, and absence of nitrogen, including vegetable oils and animal fats; 3, the albuminous group, containing a large proportion of nitrogen, comprising animal and vegetable substances allied in chemical composition to albumen and animal tissues. The saccharine substances taken as food do not directly form part of any animal tissue, but are decomposed in their passage through the circulation, and are thus employed in some unknown way in the nourishment of the body. Starch is converted into sugar during digestion, and the sugar thus formed, as well as that taken under its own form with the food, is decomposed and appropriated as above. These substances, however, are not sufficient by themselves for the support or growth of the body, as is proved by the death from inanition of animals fed exclusively upon them. The articles of the albuminous group serve not only for nutrition, but for the maintenance of heat by their decomposition; the proportion of their four elements is the same in all, and they are all capable of reduction to a like condition by the digestive process, so that, as far as nutrition goes, the fibrine of animals, the albumen of eggs, the caseine of milk, and the gluten of wheat are equally acceptable to the organism. No one of these, however, is alone sufficient to support life. It is very remarkable, as Dr. Prout has observed, that milk, the only single article of food naturally provided for the continued growth of animals, contains albuminous caseine in its curd, a good deal of oily matter, and considerable sugar.—Supposing mastication to have been thoroughly performed, the food is first acted upon by the salivary fluid, which is secreted by the parotid, sublingual, and submaxillary glands, and the fol-

licles of the mucous membrane of the mouth. Saliva is but little heavier than water, contains minute corpuscles and epithelial scales, and in health has an alkaline reaction greatest during and after meals. It consists of about 995 parts of water in 1,000, and 5 parts of solid matters. Of the latter the most remarkable is ptyaline, to which the peculiar properties of the fluid are due; it closely resembles, but is not identical with, albumen and caseine; it acts the part of a ferment, and, according to Mialhe, 1 part is sufficient to convert 2,000 parts of starch into sugar; it also contains a compound of sulpho-cyanogen, not known to occur in any other animal product, and interesting in a medico-legal point of view. Its salts are nearly those of the blood, and its alkaline reaction seems to be due to the basic phosphate of soda. The "tartar" of the teeth and salivary concretions consist principally of earthy phosphates and animal matter. The limpid secretion of the parotid and sublingual glands saturates the food during proper mastication, while the viscid submaxillary fluid facilitates swallowing. The amount of saliva secreted daily by man will average, according to Bider and Schmidt,  $3\frac{1}{2}$  lbs., though it varies with the character and frequency of the meals. Besides its mechanical action, the saliva, by its peculiar ferment, has the power of acting chemically upon the farinaceous elements of the food, leading to the conversion of the starch into sugar; but there is reason to believe that this action does not go on in presence of the acid of the stomach. There is no satisfactory evidence that saliva exerts any other than a physical action upon nitrogenized substances. When the food reaches the stomach the digestion is continued by the gastric juice, secreted by the numerous follicles of the mucous membrane, lined with glandular epithelium. The nature of the digestive process has been the subject of much speculation. It was at first supposed that the aliments underwent a cotion similar to that which they would experience in a vessel with hot water; to this succeeded the theory of acid fermentation, then of putrefaction, of trituration, and of maceration, till the present belief in the solvent action of the gastric juice was established. The gastric juice is transparent, nearly colorless, and without viscosity. Its most characteristic feature is acidity, which is even perceptible to the taste. Many eminent chemists maintain that the real agent in the solvent process is free lactic acid, while others are in favor of free hydrochloric acid; the former opinion seems to be more fully borne out by the results of experiment. The peculiar organic ferment of the gastric juice is pepsin, which disposes albuminous matters to undergo solution by the contained acid, which they would otherwise only partially do unless exposed to a high temperature. The secretion of the empty stomach is neutral or alkaline, but it becomes acid on the introduction and during the diges-

tion of food, resuming its neutral character when this process is finished. From the experiments of Dr. Dalton, it appears that an ounce of gastric juice of the dog will dissolve a little over 30 grains of fresh lean meat; at this rate the full digestion of a pound of raw meat would require two gallons of gastric juice; and this apparently enormous quantity will not be considered incredible, if it be recollected that this fluid after it has done its work of solution is at once reabsorbed into the circulation, so that even this quantity might be secreted during the three or four hours of the digestive process, at an expense to the blood of not more than 2 or 3 oz. of fluid at any one time; the fluid does not accumulate in the stomach, but its watery portions are in continual process of secretion and reabsorption as long as any food remains undigested, within reasonable limits as to quantity ingested. Many of the most important phenomena of gastric digestion were first demonstrated about 1830 by the experiments of Dr. Beaumont on Alexis St. Martin, through an opening in whose stomach the effect of food, stimulants, and sedatives could be seen. The color of the membrane was pale pink, its appearance velvet-like, and its surface lined with a transparent viscid mucus; the stimulus of food caused the gastric follicles to enter into activity, and to pour out the acid gastric juice; small quantities of very cold water, or ice, after the primary sedative effect, caused turgidity of the membrane and copious secretion, while ice in large amount and long continued retarded the process. The amount of gastric juice secreted depends on the requirements of the system, and not on the quantity of food taken into the stomach; this is most important to be remembered, since, after the fluid secreted has dissolved all it can, any excess of food must remain undigested, pass into the intestines in a crude state, and become a source of pain and irritation until it is expelled. When the system is diseased, there is no craving for food, which if taken would not cause the secretion of the gastric juice, but would remain undigested for an indefinite time, adding its irritation to the general diseased state. The secretion of gastric juice is influenced by, though not dependent on, nervous agency; it is well known that strong mental disturbance will put a stop to the digestive process, and section of the pneumogastric nerves arrests for a time the elaboration of the gastric fluid. There can be no doubt that gastric digestion is essentially a process of chemical solution, the solvent fluid being prepared by the follicles of the stomach, and its action assisted by the peristaltic muscular movements of the organ; the experiments on St. Martin, and those subsequently performed on the lower animals, fully prove these facts, both in natural and artificial digestion.—Rapidly of digestion depends so much on the quantity and quality of the food, the state of health, the condition of the mind, and

the habits of exercise, that it is difficult to determine the relative digestibility of different articles of diet. It appears from Dr. Beaumont's researches that, other things being equal, the flesh of wild animals is more easily digested than that of the allied domesticated races; in this respect venison stands first, then turkey, then beef, mutton, and veal, in the order mentioned. A certain bulk of food is necessary for healthy digestion, as has long been practically known by uncivilized nations; soups and fluid aliment are not more readily chymified than solid substances, and cannot alone support the system in vigor. Moderate exercise before a meal facilitates digestion. A temperature of 98° to 100° F. is requisite for the perfect action of the gastric juice; hence the ingestion of cold and iced substances, if carried to such an extent as to depress the temperature of the stomach, must be very prejudicial to digestion. The most recent experiments go to show that the action of the gastric juice is confined to nitrogenized substances, and that it exerts no influence on starchy, saccharine, or oily matters. Its action on albuminous matters is to reduce them to a complete solution, alter their chemical properties, and convert them into albuminose (a kind of modified albumen), in which form they are readily assimilated. In this condition they form definite combinations with the solvent liquid, which have been called peptones. These are not mere solutions of the respective substances in acidulated fluids; for a converting power is exerted by the pepsin, the solvent power being due to the acid of the gastric juice. The process of digestion is far from being completed in the stomach, but goes on in the intestine by the continued action of the gastric juice, as well as by that of the pancreatic and intestinal juices. Of these, the intestinal juice seems to have the power of rapidly transforming starchy matters into a form of sugar, while the pancreatic juice, on coming in contact with the fatty elements of the food, converts them into a finely divided milky-looking emulsion, known as chyle. All these substances, the fluid products of digestion, are then gradually taken up by the blood vessels and lacteals of the alimentary canal, and mingled with the general mass of the circulating fluid; until in the lower part of the intestine there are left only the indigestible and refuse parts of the food, mingled with the excrementitious substances of the large intestine. (See ALIMENT, ALIMENTARY CANAL, and DIETETICS.)

**DIGGES. I. Leonard**, an English mathematician, born in the parish of Barham, Kent, died about 1574. He was educated at Oxford, possessed an ample fortune, and devoted himself to mathematical studies. He wrote "Tectonicum, briefly showing the exact Measuring and Squares Reckoning of all manner of Lands, Squares, Timber, Stones, Steeples, &c." (1556); *Pantometria*, a practical geometrical treatise (1591); and "Prognostication, Everlasting of

right good effect, or Choice Rules to judge the Weather by the Sun, Moon, and Stars" (1555).

**II. Thomas**, son of the preceding, died in 1595. He graduated at Oxford, adopted the profession of a soldier, and was appointed muster-master general of the forces sent out by Elizabeth to assist the Netherlands. He wrote several mathematical treatises and other works, among which are: *Alæ, seu Scalæ Mathematicæ* (1573); "A Letter on Parallax" (1573); and "A Perfect Description of the Celestial Orbs according to the most ancient Doctrine of the Pythagoreans" (1592).

**DIGITALIS**, a genus of exogenous plants belonging to the natural order *scrophulariaceæ*. *Digitalis purpurea* (Linn.), purple foxglove, is a small herb found wild in Europe about hedges on banks of streams, in a gravelly or sandy soil. Calyx 5-parted, unequal; corolla campanulate, the limbs obliquely 4-lobed; stamens 4; stigma simple; capsule ovate-acumi-



*Digitalis purpurea*.

nate; root of numerous long slender fibres, biennial; stem erect, 3 or 4 ft. high, commonly simple roundish with slight angles, downy; leaves dull green, alternate, ovate-lanceolate or elliptic-oblong, crenate, downy, rugged, and veiny, tapering at the base into winged footstalks, lower ones largest; raceme terminal, long, simple, of numerous large, pendulous, odorless flowers. Fuchs is regarded as the earliest botanist who mentions this plant, which he named *digitalis* (Germ. *Fingerhut*, thimble), on account of the blossoms resembling the finger of a glove. The term foxe-glove occurs in a MS. *Glossarium Ælfrica*, written before the Norman conquest, and in a MS. Saxon translation of Apuleius, both of which are among the Cotton MSS. in the British museum; but no Latin or Greek name was given to this plant previous to Fuchs in 1542.—This beautiful plant derives its chief interest from its medicinal properties, which reside in the leaves and seeds, the latter being small, round-



ish, and grayish brown. Its active principle is digitaline, a yellowish bitter, uncrystallizable powder, neither acid nor alkaline, only slightly soluble in water and ether, but very soluble in alcohol. Unfortunately for medicinal ends, it has no very well marked reactions, and in one case of criminal poisoning the evidence of its use consisted chiefly in the fact that a substance extracted from the stomach and ejecta of the person killed produced in animals, when given to them, symptoms resembling those produced by digitalis. The effect of digitalis has been tried on dogs, horses, rabbits, turkeys, domestic fowl, and frogs, and on all it has been found to act as a poison. The cerebro-spinal symptoms observed in animals are diminished muscular power, convulsive movements, tremors, and insensibility. When given in small doses to man, it is found to exercise a remarkable influence over the circulation, frequently reducing the pulse from 70 or 80 to 40 or 50 beats in the minute. According to recent views, the beats of the heart, although retarded by digitalis, are rendered more vigorous by it, and at the same time the smaller arteries are contracted, so that their tension is maintained, and in some diseases increased, in spite of the slow pulse. The therapeutic effects of digitalis, including its diuretic action, depend almost wholly upon the improved tone of the heart and blood vessels which it brings about. Small doses of it in health generally, but not always, increase the water of the urine to a slight degree, the solids undergoing but little change. When poisonous doses are approximated, the force of the heart and tension of the arteries fall, and the pulse becomes first irregular, and afterward rapid. Nausea and vomiting are early toxic symptoms. It should be borne in mind that a toxic condition may be suddenly developed during the use of digitalis as a medicine, in consequence of its accumulation in the system. Its undoubted beneficial effects in organic diseases of the heart can in most cases be best attained and preserved by keeping the dose strictly within the limits of what has just been described as the first stage of its action; that is, the stage in which the tension of the blood vessels is maintained. Digitalis is used chiefly in organic diseases of the heart, to fulfil indications suggested above. Its effect in dropsies, and possibly in some nervous affections, is secondary. The infusion, tincture, leaves in powder, and granules of digitaline are all used in medicine. Its effects may also be obtained by the application to the abdominal surface of cloths steeped in an infusion of it. The dose of the infusion is about a tablespoonful; of the powdered leaves, a grain; of the tincture, 10 to 15 drops; of digitaline,  $\frac{1}{10}$  of a grain. Large quantities of digitalis are quite inert, either from too long keeping or from having been taken from immature plants.

**DIGITIGRADES**, the tribe of the typical carnivora, so called because they walk on the

ends of the toes, as distinguished from the plantigrades, which, like the bear, place the whole foot upon the ground. This tribe includes the *mustelidæ* or weasels, the *canidæ* or dogs, and the *felidæ* or cats. All have the cheek teeth with cutting edges, the lower shutting within the upper, dividing the flesh of their prey like the blades of scissors. As their food would indicate, they have a simple stomach and a short intestine. Their carnivorous propensity may be measured by the tubercle or heel on the lower carnivorous tooth, and the number of false molars in front and of tuberculous teeth behind it; those having the simplest carnivorous teeth, and the fewest molars in front and behind, like the cats and the weasels, are the most sanguinary. The characteristic marks in the skeleton are the long metacarpus and metatarsus, the elevation of the os calcis, and the shortness of the phalanges which alone rest upon the ground; and in the cats, the retractile claws. The extremities are formed for leaping and springing; from the pelvis as the fixed point, the three portions of the limbs are movable in alternately opposite directions; by the simultaneous flexion of these joints, and their sudden extension by powerful muscles, the greatest force is given to the spring, the elevated and elongated heel affording the principal mechanical advantage in the digitigrade foot.

**DIGNE** (anc. *Dinia*), a town of Provence, France, capital of the department of Basses-Alpes, situated near the Bléone, 69 m. N. N. E. of Marseilles; pop. in 1866, 7,002. It is the seat of a Catholic bishop, a court of the first resort, a communal college, a theological seminary, and a normal school. It has a public library of about 3,000 volumes, and manufactories of leather, cloth, and hats. Its situation is picturesque, but the streets are crooked, and the houses very poor. In 1629 the plague reduced the population from 10,000 to 1,500.

**DIJON** (anc. *Divio*), a town of France, formerly capital of the duchy of Burgundy, now of the department of Côte-d'Or, situated at the confluence of the rivers Ouche and Suzon, on the railway from Paris to Lyons, 160 m. S. E. of Paris; pop. in 1866, 39,193. It is of an oval form, with several suburbs, and lies at the foot of a chain of mountains in a fertile vale. It is generally well built, has numerous handsome public places and elegant houses, is enclosed by ramparts, and its environs furnish delightful promenades. It contains many remarkable buildings, the principal of which are the cathedral, formerly the Cistercian abbey of St. Benigne, a massive edifice founded in 535 and rebuilt in the 12th century, and again in the 13th, which contains the magnificent mausoleums of Philip the Bold and of John the Fearless; the church of Notre Dame, built in the 13th and 14th centuries; the church of St. Michael, which dates from the 16th century, remarkable for its front and its castle-like solidity; an ancient castle, the work

of Louis XI., which served for a time in the 18th century as the prison of the duchess de Maine, Mirabeau, and the chevalier d'Éon; and the ancient palace of the dukes of Burgundy, subsequently the *palais des états*, now occupied partly as a town hall and partly as a museum of painting and sculpture, containing numerous relics of the middle ages, and a library of 70,000 printed volumes and 800 to 900 MSS. The tower is now used as an observatory. The hall of justice, an ancient edifice, was the parliament house of Burgundy. The theatre is one of the finest in France. Dijon is the seat of a bishop and of courts of appellate and original jurisdiction. It is well provided with benevolent and educational in-

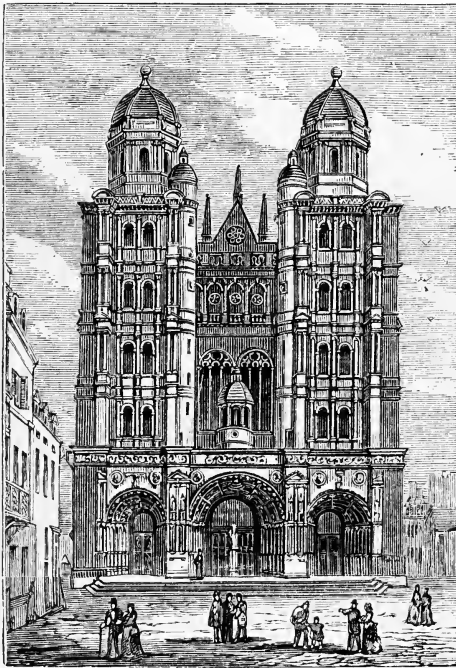

Cathedral of Dijon.

stitutions, including two hospitals, an orphan asylum, two prisons, a cabinet of natural history, a botanic garden, a university with 16 professors and faculties of law, science, and literature, eight colleges, a normal school, and schools of fine arts and medicine. It has manufactories of linens, hosiery, vinegar, and candles, distilleries, bleacheries, sugar and wax refineries, tanneries, breweries, and establishments for the manufacture of *liqueur de cassis* or black-currant wine. It is the principal market for the sale of Burgundy wines, and there is also a large trade in grain, flour, and wool.—The origin of Dijon is traced back to times preceding the Roman dominion. Under Marcus Aurelius it was surrounded by walls flanked with towers, and it was embellished

and enlarged by Aurelian. It was burned by the Saracens in the 8th century, sacked by the Normans in the 9th, and again ravaged by fire in 1127. It was for three centuries the residence of the dukes of Burgundy, by whom its present fortifications were constructed. In 1513 it was besieged by the Swiss, and saved itself only by a humiliating treaty. On Oct. 30, 1870, there was a sharp encounter between a division of the German corps of Gen. Von Werder and the advance troops of the French army of Lyons, which led on the next day to the capitulation of the town and its occupation by the Germans. On the approach of the army of Bourbaki the town was evacuated by the Germans, Dec. 27. On Jan. 21 and 23, 1871, severe fighting again took place near Dijon between the Garibaldians and portions of the second German army corps; the latter were finally compelled to retreat, leaving behind them a flag, the only one lost in the war. Dijon is the birthplace of some of the most eminent men of France, including Bossuet, Crébillon the elder, Piron, Cazotte, Guyton de Morveau, and Maret, duke of Bassano.

**DIKE** (Dutch, *dijk*, from the root of *dig*).  
**I.** Primarily a ditch, but now more commonly a wall or embankment intended to restrain the flow of water. Such earthworks were in former times a common means of defence, and were built around castles and fortresses. In Holland are the most remarkable dikes in the world, constructed to prevent the overflow of the lands reclaimed from the sea. Their importance may be appreciated from the fact that a single inundation from the sea in the year 1277 caused the destruction of 44 villages; and in 1287 80,000 persons were destroyed by another, and its present extent and shape were given to the Zuyder Zee. In the 15th century about 100,000 persons were destroyed through the imperfection of the dikes, when their construction was undertaken in the most thorough manner, and a law was enacted enforcing their being kept in order. At present this work is conducted on a systematic plan and at great cost. Embankments are made toward the sea with heavy timbers filled in with stone, and the surface is covered with bundles of flags and reeds fastened down by stakes. Piles also are driven into the sand, and protected by planking as well as by earth, turf, and stones. These artificial dikes are often 40 ft. above ordinary high water, and wide enough at top for a common roadway. Frequently the slopes are covered with wickerwork made of willow twigs, and the willow tree is extensively cultivated to furnish supplies of these, which require frequent renewal, as also to bind together by its roots the loose sands. Walls of masonry are built in some of the most exposed situations, and rows of piles outside protect the dikes from the action of the waves. The expenditure in Holland for maintaining dikes and regulating the water levels is annually from \$2,000,000 to \$2,500,000. Engineers are constantly employed,

and every provision is made of materials that may be required for immediate repairs. During the winter months watchmen patrol the dikes by day and night, and give alarm whenever the tide threatens to overflow. The people then hasten to the point, and with mats of straw and rushes and large sheets of sail cloth buried in the sand they raise a temporary bulwark, to be more securely built before the approach of the next tide.—Dikes constructed as barriers for reservoirs are built on several well established plans. The loose materials excavated for the channel or basin are piled up in a firm bank and consolidated by rolling with heavy rollers. Sometimes they are rendered more secure by building within them along their central line a puddle bank of selected clayey earth, mixed with sufficient sand to give it tenacity, so as not to crack in drying. This should be carried down to a solid foundation, and may be advantageously bedded upon a layer of concrete. It is built up a little later than the bank on each side of it, and both are rolled on the addition of every layer of six inches with a heavily ribbed roller of cast iron. The use of any material of the nature of quicksand is to be carefully avoided in any part of the embankment. Next the water it is well to face the work with a layer of broken stone that will pass through a two-inch ring, and over this should be laid a sloping wall of flat stone at an inclination of 1 base to 1 vertical, or from that to one of 3 base to 1 vertical. The broken stone within is a guard against the embankment being penetrated by any small water animals. The dike around the great reservoir of 106 acres in the Central park, New York, is made on the plan given above, which is approved by the engineers of France and England. It is 16 ft. 8 in. wide at top, with an inner and outer slope of  $1\frac{1}{2}$  base to 1 vertical. The puddle bank of clay in the middle, which reaches to within a few feet of the top, is 16 ft. thick. The depth of water around the margin is 34 ft. At the surface of the water the thickness of the embankment is 24 ft. 9 in., and at 30 ft. below it is 114 ft. 9 in. The French engineers give the preference to this mode of construction over that of a wall of masonry alone or of an embankment within a wall. Stonework by settling is liable to injury that can be repaired only at great cost, especially if the structure be concealed within an embankment. Where room is an object, as in the streets of a city, the outer sides of the dike are conveniently held up by steep walls of stone, which add neither to the strength nor to the impermeability of the work. **II.** In geology, a wall of trap or other igneous rock, which traverses other rocks, and appears to have been produced by the flowing of melted matter into a deep rent or fissure. Dikes are distinguished from veins by the greater uniformity of their contents, by the parallelism of their sides, by their not ramifying into smaller veins, and by their usually larger dimensions. The name

was given them from their frequently projecting above the surface like a wall, owing to the degradation of the softer rock around them, dike being in the north of England and in Scotland a provincial name for wall. They are from a few inches to more than a mile in thickness. In volcanic eruptions they are seen in process of formation, as deep rents open and are filled with liquid lava. In the English coal mines trap dikes are occasionally met with, forming walls across the line of the coal beds, cutting them off, and causing them at times to be thrown out of place. In the United States they occur likewise in the gold mines of North Carolina. In the Connecticut valley, in fissures of sandstone, as well as in New Jersey, the trap dike contains copper ore, indicating that the copper veins in these rocks have a common origin with the dikes, and also with the barytes which forms the gangue or matrix of the vein. Prof. Dana remarks that the triassic formations along the Atlantic appear to be a repetition of the processes which occurred in the Huronian and Potsdam periods in the Lake Superior region. The trap rocks of Lake Superior are often remarkable for the grandeur of their basaltic walls and columns.

**DILKE.** **I.** Charles Wentworth, an English journalist, born Dec. 8, 1789, died Aug. 10, 1864. He graduated at Cambridge, and early found employment in the navy pay office, where he remained 20 years. In 1830 he became editor and proprietor of the "Athenæum," which speedily rose to a high rank in English periodical literature. In 1846, having intrusted the editorship of the "Athenæum" to Mr. Thomas Kibble Hervey, Mr. Dilke undertook that of the "Daily News," from which he retired in 1849. A valuable collection of "Old English Plays," in 6 vols., was edited by him in 1814. **II.** Sir Charles Wentworth, son of the preceding, born in London, Feb. 18, 1810, died in St. Petersburg, May 10, 1869. He was educated at Westminster school and Cambridge, and from his interest in art was one of the earliest and most active promoters of the crystal palace exhibition of 1851. He declined the knighthood offered him for his services on this occasion, and also refused any pecuniary reward. He was a commissioner to the New York crystal palace exhibition in 1853, and one of the five royal commissioners of the second London exhibition in 1862, in which year he was created a baronet. He was active in the society of antiquaries and the royal geographical society. He sat in parliament for Wallingford from July, 1865, to November, 1868. **III.** Sir Charles Wentworth, an English author and politician, son of the preceding, born in Chelsea, Sept. 4, 1843. He was educated at Cambridge, where he graduated in 1866, and was called to the bar. He travelled in Canada and the United States, crossing to the Pacific coast, and sailing thence for Australia and the other British colonies in the South sea. The result of these travels he

published in "Greater Britain: a Record of Travel in English-speaking Countries during 1866-'7" (2 vols., 1868). In 1868 he was elected to parliament from Chelsea, by a majority of two to one over Dr. W. H. Russell. On the death of his father he became editor of the "Athenæum." In politics he is a republican, and has attracted much attention by his attacks on the monarchical system.

**DILL**, the common name of the *anethum graveolens* (Linn.), an annual plant of the natural order *umbellifera*, a native of Spain, but naturalized in the south of France and Germany, and cultivated in gardens in the United States. It has an upright smooth stem, much dissected leaves, yellow flowers, and small oblong seeds, with sharp, filiform dorsal ridges. The seeds and oil distilled from them are aromatic, but have no properties to distinguish

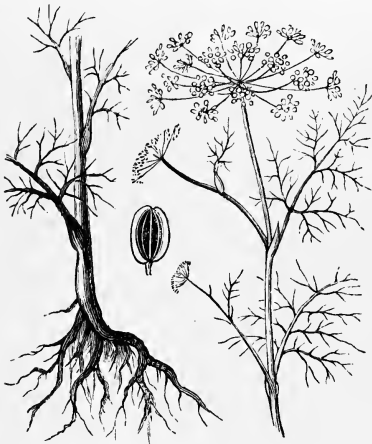

Dill (*Anethum graveolens*).

them from many other members of the same class of substances. The seeds are imported in large quantities from the south of France into England, where they are employed in the manufacture of British gin. In Germany they are used in pickling cucumbers and in the flavoring of sour crout.

**DILLENIUS, Johann Jakob**, a German botanist, born in Darmstadt in 1687, died in Oxford, April 2, 1747. His grandfather was called Dill and his father Dillen, which the son Latinized into Dillenius. He studied at the university of Giessen, and was received into the society of "Inquirers into Nature," under whose auspices he published a "Dissertation upon the Plants of America naturalized in Europe;" a "Treatise upon Coffee," with an account of the substances which might displace it, giving the preference to burnt rice; and a volume of "Observations upon the Mode of Development of Ferns and Mosses," in which he confirmed the theory of different sexes in plants. He first obtained a reputation among naturalists by his *Catalogus Plantarum circa Gissam nascentium*,

published in 1719. William Sherard, a scientific English traveller, persuaded Dillenius to leave Germany for England. He arrived in London in 1721, and had a fine garden at Eltham placed at his disposition by James Sherard, a brother of William. He edited an enlarged edition of Ray's "Synopsis of British Plants," with engravings of his own. In 1728 William Sherard died, and founded by his will a chair of botany at Oxford, to which Dillenius was appointed, who in 1732 published his *Hortus Elthamensis*, containing not only descriptions of plants arranged in alphabetical order, but also 324 plates engraved by himself. This work was enthusiastically received by his contemporaries, among others by Linnaeus, then commencing his labors. In 1741 he published his *Historia Muscorum*, which places him in the first rank of the botanists of the last century. He was more than 20 years in collecting the materials of this work. The plates (numbering 85) and the descriptions were all by his own hand. He published no subsequent work, but many of his drawings and collections are preserved in the Sherardian museum at Oxford. Linnaeus dedicated to him a magnificent genus of plants of tropical India, which is the type of the family of the *Dilleniaceæ*.

**DILLINGEN**, a town of Bavaria, in the circle of Swabia, on the Danube, 22 m. N. W. of Augsburg; pop. about 5,500. The university, founded in 1549, and from 1564 to 1773 under the management of the Jesuits, was abolished in 1804. There is now a lyceum with a library of 75,000 volumes. Other conspicuous buildings are the Jesuit college, the palace of the bishops of Augsburg, and a royal castle. It has an asylum for the deaf and dumb. A new bridge has recently been thrown over the Danube, and a canal to Lauingen has been constructed to avoid the windings of the river between the two places. The town belonged to the bishop of Augsburg till 1803, when he was deprived of his secular estates.

**DILLMANN, Christian Friedrich August**, a German orientalist, born at Illingen, Württemberg, April 25, 1823. He studied at Tübingen, and after a visit to the oriental museums of Paris and London resided for several years at the university as a private teacher. In 1854 he became professor of oriental languages at Kiel, and in 1864 professor of Old Testament exegesis at Giessen. In 1869 he succeeded Hengstenberg at the university of Berlin. His fame rests mainly on his great labors in behalf of the Ethiopic language. His principal works are: *Grammatik der äthiopischen Sprache* (Leipsic, 1857); *Lexicon Linguae Æthiopicæ* (1862-'6); and *Chrestomathia Æthiopicæ, edita et Glossario explanata* (1866).

**DILLON, Peter**, a British navigator, born about 1755, died in 1847. He early entered the merchant service, and barely escaped being murdered by the Feejee islanders while lieutenant of an East Indian ship. In 1826 he met three of his former companions on an

island in the South sea, where they had been left 13 years before. One of these men had learned that two vessels had been lost on one of the Vanikoro islands, and had discovered some of the articles found on the wrecks. Dillon recognized these as having belonged to the expedition of La Pérouse, and returning to Pondicherry was put in command of a vessel, which in July, 1827, reached Whannon, an island of the Vanikoro group, where were found additional traces of the expedition of La Pérouse. Dillon reached France on his return in February, 1829, and received from Charles X. a gift of 10,000 francs and a pension of 4,000. He wrote a narrative of his expedition, under the title of *Voyage aux îles de la mer du Sud, 1827 et 1828, et relation de la découverte du sort de La Pérouse.*

**DILMAN**, a town of Persia, in the province of Azerbaijan, 75 m. W. by N. of Tabriz, on a stream flowing E. into the N. end of Lake Urumiah, 10 m. distant; pop. about 15,000. It is a modern town, situated in an extensive and fertile valley, and surrounded by gardens, with more cleanly streets than those of older Persian towns. About 4 m. W. is a decayed ancient town of the same name.

**DILUVIUM**, or *Drift*, the superficial deposits of clay, sand, gravel, and boulders which in both hemispheres are spread more or less uniformly over the land of the polar regions and the adjacent portions of the temperate zones. Geologically this deposit is very recent, and is found overlying strata of later tertiary or pliocene age. Inasmuch as great portions of the material of which it is composed seem to have been transported or at least accumulated in their present position by some violent action, the name of diluvium was given to it by the earlier geologists. In the northern hemisphere the drift is found alike in Europe, Asia, and America, extending from the polar regions toward the equator, and disappearing on the continent of North America about lat. 38°; while in Europe all traces of it are said to be lost in the countries bordering on the Mediterranean. In South America it is recognized from Cape Horn northward into southern Chili, and according to some observers much further. The assertion that great deposits of such material occur even in tropical Brazil is denied by the more recent observers. This drifted or diluvial material is divided into diluvium proper, or unstratified drift, and stratified or modified drift, which is the result of a rearrangement of the former by water. Unstratified drift is met with at considerable elevations over the present sea level—3,000 ft. above the Baltic, and at a height of 4,000 ft. in the Grampians of Scotland. It is everywhere characterized by loose masses of rock, more or less rounded, which in many cases have evidently been transported for considerable distances from their parent beds. As already described in the article **BOWLERS**, they are often of great dimensions, and increase in size as the deposit is traced

toward its source to the northward. In Russia they have thus been identified with ledges more than 800 m. distant toward the north. Boulders of the same kind of granite, easily recognized, traced from Moscow to St. Petersburg, vary from two or three feet in diameter at the former to as many yards at the latter point. Instances of these phenomena are everywhere to be seen in the northern United States. In southern Wisconsin pieces of native copper were often found in the superficial deposits long before the mines of this metal were discovered on the S. shore of Lake Superior, 300 m. to the north. The N. shores of Long Island are strewn with boulders of red sandstone, and of granite and other primary rocks, arranged in groups which correspond with the position of the ledges of the same rocks in Connecticut. So on the European continent, the stratified rocks of which the whole region on the S. side of the gulf of Finland is composed are covered with granitic boulders from the primary region of Scandinavia on the other side of the gulf. These boulders, or erratic blocks, are in some places the only evidences of diluvial action, and are found resting directly upon the solid rocks; but in such cases they have been left in this position by the subsequent washing away of the finer portion of the original diluvium or unstratified drift, in which they were included. This may be described as a heterogeneous mass of clay with sand and gravel in varying proportions, enclosing the transported fragments of rock, of all dimensions, partially rounded or worn into wedge-shaped forms, and generally with surfaces furrowed or scratched, the whole material looking as if it had been scraped together. Such is the unstratified diluvium, or boulder clay, as it is sometimes called; while in allusion to its supposed accumulation by the agency of ice, it is often designated glacial drift. The rocks beneath this deposit are worn smooth or polished, and more or less deeply grooved or striated in a manner which shows unmistakably that the drift has been made to move over the surface with great force, grinding, planing, and scoring the rocks beneath. Resting on this deposit are generally found accumulations of stratified clays and sands, evidently arranged by deposition from water, which are known as stratified drift, or modified drift.—The characters, relations, and distribution of these various products of diluvial action in North America have been studied with great care by Newberry and by Dawson. The latter has recently published a valuable summary under the title of "The Post-pliocene Geology of Canada." Nowhere are the phenomena of this geological period better seen than in the valley of the St. Lawrence and its tributaries. Dawson divides the deposits of this drift formation into three parts: the first, or lowest, the so-called boulder clay; the second, or leda clay, a fine deposit in deep waters; and the third, or saxicava sand, an accumulation of shallow-water sand

and gravels. These three deposits in the valley of the St. Lawrence can often be seen in actual superposition, and the order is invariable. In some places all contain marine shells; in others these are limited to the upper part of the leda clay or the lower part of the saxicava sand. In many parts of its distribution the boulder clay holds the remains of marine animals, stones with adhering barnacles and bryozoa being imbedded therein; and elsewhere, according to Dawson, it exhibits other but not less unequivocal evidences of a submarine origin. The true boulder clay is spread out over the region under consideration as a somewhat widely extended and uniform sheet; yet it may be said to fill up all small valleys and depressions, and to be thin or absent on ridges or rising grounds. The boulders which it contains are by no means uniformly dispersed. When cut through by rivers or denuded by the action of the sea, ridges of boulders are often seen to be enclosed within it. It is to be observed, according to the same writer, that although boulders with layers of stones occasionally occur in the leda clay, and the upper sands and gravels sometimes contain large boulders, such deposits are readily distinguished from the true boulder clay. Although generally resting directly on striated rock surfaces, it is sometimes overlaid by rolled gravel or by peat. It is usually destitute of stratification, but horizontal lines, indicating differences in texture and in color, can sometimes be seen, and it occasionally exhibits surfaces on which lie large boulders, striated and polished on their upper sides, forming a sort of pavement. The rocks underneath this boulder clay are very generally polished and striated in a manner similar to those seen beneath Alpine glaciers. The grooves in the region under consideration belong to two series, one evidently produced by a force moving to the southeast, and the other to the southwest. The southwest set prevails in the valley of the St. Lawrence, in western New York, and around Lakes Huron, Superior, and Michigan. Nearly at right angles is another set, directed to the southeast, found to the north of Lake Ontario, in the valleys of the Ottawa and Lake Champlain, and in the highlands of eastern Canada and New England. These, according to Hitchcock, are seen in Vermont at a height of 4,800 ft. above the sea. In some localities the two sets of striæ are found in the same region, and even intersecting one another. Resting upon the boulder clay, and apparently made up from the rearrangement of its finer portions, we find the leda clay of Dawson, so called from the abundance of the shells of *Leda truncata* which it contains. It is the Champlain clay of Dana. In many parts it also abounds in other shells, in *foraminifera*, and in some localities in the remains of fishes; its fauna being, alike in Canada and New England, of a somewhat arctic type, and identical with that of the gulf of St. Lawrence

at the present time. Resting upon this clay is found in many localities a stratified sand in which abound the shells of *saxicava rugosa*. In some cases the passage from the one into the other is gradual, while in others there seems to have been an interval marked by the denudation of the underlying clay. In some localities, however, this sand rests on the boulder clay, and where this is wanting, directly on the rock, which in this case is often striated, and was probably once covered by the boulder clay, which was afterward swept away. These stratified fossiliferous clays are found at heights of 500 and even 800 ft. above the present level of the sea in eastern North America. Ridges, terraces, and inland sea cliffs are also noticed over the region characterized by the deposits already mentioned, and are evidently closely connected with the rearrangement of the drift materials, and with the slow movement of elevation from the sea in which these stratified materials were deposited. The origin of the unstratified drift is, however, a question which has been much controverted; the point in dispute being whether this deposit has been accumulated by the action of icebergs under the sea, in the waters of which the stratified deposits were subsequently arranged, or whether it was the result of the action of land glaciers at a time prior to the depression of the region beneath the sea level. The iceberg theory was perhaps first formulated by Peter Dobson of Vernon, Conn., in a note in the "American Journal of Science and Arts" (vol. x., 1826), where he describes the scratched appearance of the boulders scattered over New England as if due to "their having been dragged over rocks and gravelly earth in one steady position," and adds: "I think we cannot account for these appearances unless we call in the aid of ice as well as water, and that they have been worn by being suspended and carried in ice over rocks and earth under water." The transportation of masses of rock by icebergs as they drift along the currents which set from the polar regions, and the distribution of their loads over the bottom of the ocean as the bergs melt away, present, in the view of many, a repetition of the process by which in remote times the surfaces of the present continents were covered with the drift materials. Lyell supposes that the lands, with their present irregularities of surface already defined, were slowly submerged, while islands of floating ice passed along in the polar currents, grounding on the coast and on shoals, and pushing forward the loose sand and gravel spread over the bottom. Thus abraded down to the solid rock, and the surface of this grooved and striated, the shoals, by continued subsidence, passed down to great depths, where the loose materials gathering upon them were no longer disturbed. Finally he supposes the direction of the movement to have been reversed, and the bottom of the ocean to have been again raised to form dry

land; and that during its reëmergence the arrangement of the materials which cover it was modified by exposure to the distributing and stratifying action of the waves, tides, and currents. The extent and immense number of modern icebergs seem to prove their capacity to reproduce upon the shoals and over the bottom of the Atlantic nearly all the phenomena of the drift formation. Measured as they are by miles in length, and rising at times more than 300 ft. in height, with only one fifth of their bulk then visible, they may well float off and distribute along their track the largest boulders which they have abstracted from the rocky cliffs down which they moved as glaciers into the sea. Of late years, however, the theory of Agassiz, that the phenomena of the drift are due not to the submarine action of floating ice, but to terrestrial glaciers, has found much favor. The vast accumulations of ice which have been so well studied in the Alps are seen in their slow and irresistible motion down the valleys to score and groove the surfaces of the rocks over which they pass, rending masses of rock from the cliffs, moving the fragments forward, and finally leaving them rolled in the shape of boulders, and grooved and scratched by the rubbing to which they were subjected when fixed in the ice. In the Alpine regions of Europe the effects thus produced are so remarkable, and spread over such extensive districts, that many geologists who have studied them are disposed to refer all the phenomena of the unstratified drift to the action of glaciers; and in this view they are confirmed by finding unmistakable evidence that the action of the glaciers formerly extended far beyond their present limits. But the unstratified drift is found to extend over vast regions where it is difficult to conceive that mountain glaciers could ever have found their way; and Agassiz, to account for this universal glaciation of circumpolar regions, has been led to maintain the existence of a great continental glacier, or ice cap, extending over the arctic and a great part of the temperate zone, moving downward from the polar region, and of such immense thickness as to surround and overflow the summits of our highest hills, which he supposes may have required in eastern North America a vertical thickness of two or three miles of solid ice. A similar continental glacier, according to this view, must have existed in the southern hemisphere. Prof. Dana, while adopting this notion of the origin of the glacial drift, regards the hypothesis of a central and common glacier source for each hemisphere as untenable, but supposes the existence of distinct glaciers of great magnitude. Such a one, according to him, had its origin along the watershed between the St. Lawrence and Hudson bay; but recognizing the necessity of an elevated source to give motion to the glacier, he supposes that this region, which is now not more than 1,500 ft. above the sea, was then raised many thousand feet above its present

level.—In these theories of land glaciation a great depression of the surface is supposed to have succeeded the glacial period, affecting in the one case the great mountain plateau to the northward, and submerging the glaciated region so as to permit the deposition above its surface of the stratified clays and sands which overlie the boulder clay. But, as we have seen, this in many parts of its distribution is clearly of marine origin; and a careful study of the whole of the phenomena of the drift period in eastern North America has led Dawson to regard the operation of land glaciers in this region as of very limited extent and importance, and to maintain that the widespread glacial drift is essentially submarine in its origin. This earlier view, which as set forth by Lyell has been partially explained above, endeavors to account for the phenomena in question by causes now in operation, rather than by supposing a condition of things which it is at once difficult to conceive and to explain. As expounded by Dawson, it maintains that at the beginning of the glacial time eastern North America was already under water, and was slowly rising, though with minor oscillations of level, from the ocean, the more western portion first. Along the eastern border of the rising land, over its still submerged plains, and through its valleys, then flowed the arctic current, as it now does along the coast of Labrador and the shores of Newfoundland, bearing great quantities of floating ice, by the action of which, combined with the current, the rocky strata were eroded, and the valleys and lake basins excavated. At an early period in this order of things, the great arctic stream, pursuing, in obedience to the force impressed upon it by the earth's rotation, a southwestern course, passed over the region of the great lakes and excavated their basins; while at a later time, diverted further eastward by the emergence of the Laurentides, it would pass along the present St. Lawrence valley, and thence southwestward to the Mississippi. To quote the language of Dawson: "The prominent southwestern striation, and the cutting of the upper lakes, demanded an outlet to the west for the arctic current. But both during the depression and the elevation of the land there must have been a time when this outlet was obstructed, and when the lower levels of New York, New England, and Canada were still under water. Then the valley of the Ottawa, that of the Mohawk, and the low countries between Lakes Ontario and Huron, and the valleys of Lake Champlain and the Connecticut, would be straits or arms of the sea; and the current, with its icebergs, obstructed in its direct flow, would set principally among these, and act on the rocks in north and south and northwest and southeast directions. To this portion of the process I would attribute the northwest and southeast striation." As the process of elevation proceeded, and the northern current found its passage across the east-

ern region to the sea, by channels further and further east, the conditions became such as to permit the deposition, from seas comparatively undisturbed, of the stratified clays and sands, which are seen in so many cases to rest upon the boulder clay, and are found with their characteristic fossils at elevations of 500 and even 800 ft. above the sea; while others, though so far as known without organic remains, are met with at still higher levels. Portions of floating ice, however, still dropped from time the rock masses with which they were freighted, in the midst of these stratified clays. Nor are evidences wanting in the lower St. Lawrence that a second invasion of icebergs may have given rise to new accumulations of boulder drift after the deposition of the stratified clays. The valleys among the hills, and the shores of the islands, which then rose above an icy sea, would be filled with the local glaciers, of which the traces still remain, which gave their tribute to the northern current, already charged as now with immense icebergs from the polar regions. These in great part submerged and half stranded masses, urged by current, wind, and tide, would plough and furrow the bottom, there piling up the unstratified heaps of boulder clay, to which the earth and rocks borne by the melting ice would contribute.—The formation of the diluvium or boulder drift is thus, according to either view, the result of the action of ice. But the glacial action, in the opinion of the land-glacialists, was limited to a definite period, and operated simultaneously over a vast area, which, according to one hypothesis, was not less than an entire hemisphere. Those, on the other hand, who restrict the action of land ice to local glaciers, and call in the aid of floating ice and the arctic current, maintain that the process of glaciation is limited rather by place than by time. Ever since the conditions of the earth have been such as to give rise to the formation of polar ice, the shores and the shallow seas to which the arctic current has borne it must have been subject to glacial action such as we have endeavored to describe. From the days in which the glaciation of our valleys and the deposition in them of the glacial drift took place, this process has not ceased, but has been transferred to other regions; and we may suppose that the banks of Newfoundland, if now raised above the ocean's level, would present striations and glacial drift, which, but for the presence of remains showing its formation to have been in the historic period, would be indistinguishable from the ancient boulder clays of New England and Canada.

**DIME** (Fr. *dime*, contraction of *dixième*, a tenth), a silver coin of the United States, of the value of 10 cents, or  $\frac{1}{10}$  of a dollar. It was first coined in 1796, in pursuance of the act of April 2, 1792, in which year pattern pieces were struck. Its legal standards have been as follows: by act of April 2, 1792, fineness 892.4 thousandths, weight 41.6 grains; by act of

Jan. 18, 1837, fineness 900 thousandths, weight 41.4 grains; by act of Feb. 21, 1853, fineness 900 thousandths, weight 38.4 grains. The half dime, of proportional weight and like fineness, was authorized by the same acts. These coins, which previous to Feb. 21, 1853, had been a legal tender for any amount, were by the act of that date made a legal tender only for sums not exceeding \$5. By the act of Feb. 12, 1873, the half dime was discontinued, and the weight of the dime was fixed at 38.58 grains, or one fifth that of the half dollar. The number of pieces coined to June 30, 1873, was: dimes 89,854,925, half dimes 97,547,938; total, 187,402,863; value, \$13,862,889.40.

**DIMSDALE, Thomas**, an English physician, born at Thoydon-Garnon, Essex, in 1712, died in Hertford, Dec. 30, 1800. He was noted for his zeal in promoting inoculation for the small-pox, and was invited to Russia by Catharine II. in 1768, for the purpose of inoculating herself and her son. He afterward visited Frederick II. of Prussia at Sans-Souci, and then returned to England, where in 1776 he published a treatise on inoculation, which was translated into all the European languages. In 1780 he was elected to the house of commons, and in 1781 made a second professional visit to Russia. He also published several pamphlets on inoculation.

**DINAGEPOOR**, a town of Bengal, India, capital of a district of the same name, in lat. 25° 34' N., lon. 88° 45' E., 210 m. N. of Calcutta; pop. about 30,000. The town has a large square in the centre surrounded with shops, but there are no public buildings of any consequence, although it is the seat of the British judicial and revenue courts. There are no temples and but one mosque, which is small and without architectural pretensions. The dwellings of the Europeans are large and commodious, but exhibit no taste, while those of the natives are mere huts. The trade of the place is inconsiderable.

**DINAN**, a town of Brittany, France, in the department of Côtes-du-Nord, on the Rance, 30 m. N. W. of Rennes; pop. in 1866, 8,510. It occupies a commanding and romantic site on the crown and slopes of a steep hill overlooking the narrow valley of the Rance, which flows 250 ft. below its summit. It is surrounded by a high wall, pierced by four gates, which anciently had 54 round towers, but has now but 16. The old and picturesque castle, built about 1300, is now a prison. On the outside of the walls, now overgrown with ivy, are beautiful terraces and gardens in the former moat. There are some fine specimens both of ancient and modern architecture. In one of the four open places is a statue of Du Guesclin, who successfully defended the town against the English in 1359. Its port can admit vessels of 90 tons burthen, and it has a considerable coasting trade. Its manufactures consist chiefly of linen, cotton, and woollen goods, leather, beet-root sugar, and salt. In the en-



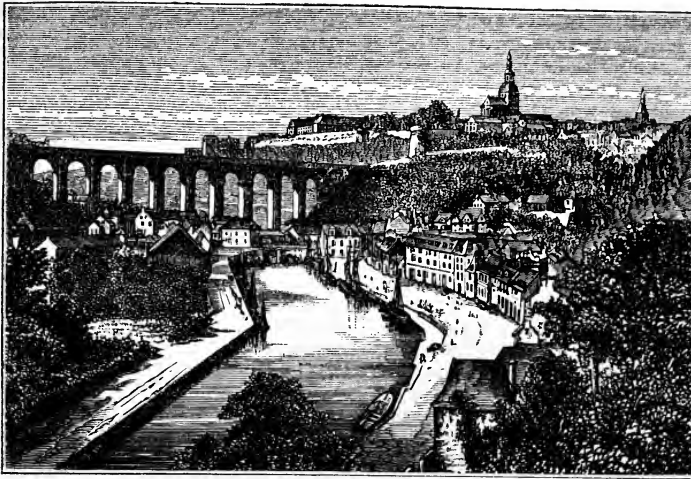

Dinant.

virons are chalybeate springs, much resorted to. It was often besieged in the middle ages.

**DINANT**, a town of Belgium, on the Meuse, 14 m. S. of Namur; pop. about 7,000. It is situated at the base of limestone cliffs, on the summit of which are a citadel and a chapel. The cliffs are accessible by winding stairs cut in the rock from terrace to terrace nearly up to the walls of the fortress. The town has only one narrow street, with a small market place. In the vicinity are quarries of black marble; and there are some manufactures. Dinant cakes, made of honey and rye flour, are famous. Brass and copper ware are called from this place *dinanderies*. Dinant was sacked in 1466 by Philip the Good of Burgundy, in his warfare against Louis XI., and again in 1554 by the duke of Nevers, who served under Henry II. against Charles V.; and it was captured by the French in 1675.

**DINAPORE**, a town of Bengal, India, on the S. bank of the Ganges, 10 m. N. W. of Patna and 300 N. W. of Calcutta; pop. about 16,000. It is an important military station, noted for its handsome and extensive cantonments, capable of containing 5,000 troops. Around the station are a great number of fine bungalows with small parks and gardens. The town, a confused assemblage of thatched huts and brick buildings seldom more than one story high, extends about a mile along the banks of the river. The native troops at Dinapore mutinied and gave much trouble in 1857.

**DINDORF, Wilhelm**, a German philologist, born in Leipsic, Jan. 21, 1802. His father was professor of oriental languages at the university in his native city, which he entered in 1817, and where he continued, when not more than 17 years old, the commentary and scholia on Aristophanes begun by Beck. He published subsequently a new edition of the Greek author (Leipsic, 1820-'28), and received in 1828

a professorship of the history of literature at Leipsic. He began his lectures in 1830, but resigned the chair in 1833 in order to devote himself entirely to classical labors. He went to Paris, and edited there, in conjunction with his brother and Hase, Stephens's *Thesaurus Græcæ Linguae* (1829-'63). He is one of the principal editors of Didot's *Bibliothèque des classiques grecs*, and of the Oxford and Teubner's (Leipsic) editions of Greek classics. — His brother

LUDWIG, born Jan. 3,

1805, is specially known as the editor of the writings of Xenophon, Diodorus Siculus, Pausanias, and of the chronography of Joannes Malalas.

**DINGELSTEDT, Franz**, a German poet and novelist, born at Halsdorf, in Hesse, June 30, 1814. Having studied theology and philology, and served as a professor at Cassel and Fulda, he became in 1850 intendant of the royal theatre at Munich, and in 1867 director of the royal opera house in Vienna. He has published collections of poems entitled *Lieder eines kosmopolitischen Nachtwächters* (1840), *Gedichte* (1845), and *Nacht und Morgen* (1851), and a number of romances, dramas, and books of travel. In 1840 he married Jenny Lutzer, a celebrated singer.

**DINGO**. See DOG.

**DINKELSBÜHL**, a town of Bavaria, on the right bank of the Wernitz, 44 m. S. W. of Nuremberg; pop. in 1871, 5,213. It has several fine churches, an orphan asylum, and two hospitals. It suffered heavily during the thirty years' war, and is still declining; but it has considerable manufactures of woollen hosiery, linen, paper, hats, and stone slabs for tables, besides dyeworks, a brewery, and several mills. It was formerly a free city, but came into the possession of Bavaria in 1802. It is on three hills, and its ancient walls are still standing.

**DINORNIS** (Gr. *δεινός*, terrible, and *ὄρνις*, bird), a gigantic extinct bird, whose bones have been found in New Zealand. The history of this genus, established by Owen, is one of the most remarkable examples of the correctness of the great laws of the correlation of parts so beautifully elaborated by Cuvier. In vol. iii. of the "Transactions of the Zoological Society of London" is the first paper by Owen on this subject. He had received from New Zealand a fragment of a femur, six inches long, with both the extremities broken; from its tex-

ture and size he concluded that it belonged to a bird of the struthious order, but heavier and more sluggish than the ostrich; the bone was not mineralized, and retained much of its animal matter, though it had evidently remained in the ground for some time; this was in 1839. In a second memoir, communicated in 1843, he gives descriptions of portions of the skeletons of six species of a struthious bird, named by him *dinornis*, which appeared to have become extinct within the historical period in the North island of New Zealand, as the dodo had in Mauritius. These specimens, 47 in number, had been sent to Dr. Buckland by the Rev. Mr. Williams, a missionary, who wrote that they were taken from the banks and bed of fresh-water rivers, buried only slightly in the mud, and probably quite recently; that the birds formerly existed in considerable numbers, and must have attained during a very long life a height of 14 or 16 ft. The bird to which

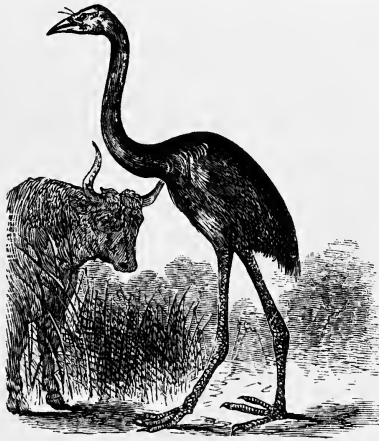

*Dinornis giganteus.*

these bones belonged was called *moa* by the natives. The names given by Owen were *dinornis giganteus*, height at least 10 ft.; *D. ingens*, 9 ft.; *D. struthioides*, 7 ft.; *D. dromioides*, 5 ft.; *D. didiformis*, 4 ft.; and *D. otidiformis*, of the size of the great bustard. From these specimens he inferred that the wings were quite rudimentary; that the large cervical vertebrae supported a powerful beak; and that its strong legs were used in scratching up the soil to obtain the nutritious roots of the ferns which are so characteristic of those islands. He draws a portrait of this gigantic bird, the highest living form in that part of the globe, with no terrestrial mammal to contest its possession of the soil before the arrival of the first Polynesian colony. In a third memoir, read in 1846, an examination of a larger number of specimens confirmed the deduction as to the rudimentary condition of the wings by the discovery of a keelless sternum; showed that the species of this essentially terrestrial genus were

heavier and more bulky in proportion to their height, more powerful scratchers, and less swift of foot than the ostrich, but in different degrees according to the species; and indicated an affinity to the dodo in the shape of the skull, with a lower cerebral development, and consequently greater stupidity. He formed a new genus, *palapteryx*, of the species *ingens* and *dromioides*, characterized by a posterior or fourth toe, the three of the *dinornis* all being anterior toes; he added the three new species, *D. crassus*, *D. casuarinus*, and *D. curtus*, all of small size. In a fourth paper, read in 1848, he establishes a new genus, *aptornis*, in which he places what he formerly called *D. otidiformis*; this has a large surface for the hind toe, a strong perforated calcaneal process, and a more posterior position of the condyle for the inner toe; it resembles the apteryx in the comparative shortness of the metatarsus. In this he describes perfect skulls and beaks of these birds, from which he concludes that the *dinornis*, though resembling the *struthionida* in the extraordinary development of the legs and the rudimentary condition of the wings, does not come very close to any existing struthious birds in its adze-like beak, crocodilian cranium, form of the pelvis, and proportions of the metatarsus. The genus *palapteryx* belongs to the *struthionida*, being in some respects intermediate between *apteryx* and *dromaius*. The law of the localization of animals, so remarkably illustrated in the recent progress of geology, receives an additional confirmation by this occurrence in the river banks of New Zealand of remains of gigantic birds allied to the small species (the *apteryx*) still existing only in the same islands. In vol. iv. of the "Transactions," in 1850, the feet and sternum are described, and two new species are alluded to, *D. rheides* and *P. robustus*; further descriptions of the skull, beak, and legs are given in the same volume. Some years before the discovery of these bones in New Zealand, attention had been drawn to remarkable impressions in the new red sandstone of the Connecticut river valley, in Massachusetts, which were believed to be footprints of birds, the largest of which must have exceeded the ostrich in size. Geologists were unwilling to admit the existence of birds at this remote epoch, or of such large ones at any time; but the subsequent discovery of *D. giganteus* demonstrated the existence of birds, at a comparatively recent period, whose tracks would have been 22 in. long and 6 wide, considerably larger than those of the Connecticut valley. The occurrence of these gigantic birds in New Zealand adds much to the evidence that similar apterous and low-organized reptilian birds existed in America during the red sandstone epoch, "the age of reptiles," when the cold-blooded and slow-breathing *ovipara* exhibited such various forms and so great a number of species. Though many of these bones are apparently recent, and though it is not impossible, in the opinion of some, that the *dinornis*,

like the apteryx, may still exist in the interior of these islands, they belong to a certain extent to the class of extinct genera. In a more recent paper in the "Proceedings of the Zoological Society," for April 8, 1856, Prof. Owen describes the *D. elephantopus*, the most extraordinary of all for the massive strength of the limbs and the general proportions of the breadth and bulk to the height; and it is the opinion of Mantell that this species existed in the Middle island with the first Maori natives. From a consideration of these species, it appears that those of the North island were distinct from those of the South.

**DINOSAURIANS**, a tribe of fossil saurians, of immense size, having many mammalian characters, such as a medullary cavity in the long bones, short, pachyderm-like feet, a sacrum of five united vertebræ, and a lateral motion of the lower jaw. They include the iguanodon, megalosaurus, &c., herbivorous and carnivorous; they are of the mesozoic age, from the middle of the Jurassic to the middle of the cretaceous epochs.

**DINOTHERIUM** (Gr. *δεινός*, terrible, and *θηρίον*, beast), an extinct pachyderm of immense size, some of whose bones have been found in the middle tertiary or miocene deposits of Europe, Asia, and Australia. A few teeth were found in France during the last century and the early part of the present. In 1829 Kaup discovered at Eppelsheim, S. of Mentz, a sufficient number of bones to lead him to form a new genus for it. In 1836 the discovery of a cranium by Klipstein seemed to settle the position of the dinotherium among the pachyderms. This head (of which casts are very generally found in cabinets) is nearly 4 ft. long, 2 ft. broad, and 1½ ft. high, its summit divided into two parts by a well marked ridge, and its occipital surface wide and oblique, with a globular occipital condyle; the nasal aperture is very large, as in the elephant and mastodon, with the large suborbital foramina indicating the possession of a proboscis. The lower jaw is remarkable for its curve downward, and its two tusks pointing in the same direction, forming a hook 3 ft. in length and describing a quarter of a circle. The primary teeth appear to have been 12, 3 on each side of each jaw, and the permanent teeth 20, 5 on each side of each jaw; the front 2 on each side, making 8, are pre-molars, and resemble those of the tapir; the upper 12 teeth, the true molars, resemble those of the mastodon in their transverse ridges, but differ from them in their square form; they are developed vertically, as in man and most mammals, while those of the elephant family are developed horizontally. If the bones of the trunk and extremities attributed to this animal really belong to it, it would have a length of 18 ft. and a height of 14, 2 ft. longer and higher than the largest mastodon discovered. The shoulder blade is like that of the mole, indicating that the fore feet were adapted for digging. It is not very easy to de-

cide whether this animal was more terrestrial or aquatic in its habits. Pictet expresses the opinion that it was a herbivorous cetacean. On the contrary, Owen, Kaup, and De Blainville

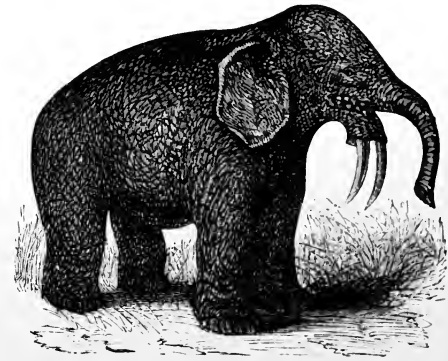

*Dinotherium giganteum.*

consider it a terrestrial proboscidian, intermediate between the mastodon and tapir. These two opinions are really not very different, since it is now generally agreed that the manati and dugong, or the herbivorous cetacea, must be removed from the order of cetaceans and placed among the pachyderms, of which last they are the embryonic type. Considering then the dinotherium to be a true pachyderm, or perhaps a connecting link between this order and the herbivorous cetaceans, its favorite element, air or water, may be a matter of question. It has no incisor teeth; its inferior tusks seem admirably adapted to drawing its heavy body out of water upon the banks of rivers, and would also serve for rooting up aquatic plants, assisted by the mole-shaped fore feet. Buckland suggests that the tusks served to anchor the animal to the shore, while it slept in the water. It cannot be far from the truth to call it an aquatic pachyderm, similar in habits to the hippopotamus. The best known species (*D. giganteum*, Kaup) was found at Eppelsheim, in clayey marl about 18 ft. below the surface, in connection with bones of other pachyderms; their remains have been found only in the miocene strata. Other smaller species are described, as the *D. Cuvieri* (Kaup), *D. minutum* (H. de Meyer), and *D. proavum* (Eichwald), in Europe; *D. Indicum* (Cautley and Falconer), from the Sivalik hills; and the *D. australe* (Owen), of Australia.

**DINWIDDIE**, a S. E. county of Virginia, bounded N. by the Appomattox river, and S. W. by the Nottoway; area, 540 sq. m.; pop. in 1870, 30,702, of whom 17,664 were colored. It has a rolling surface and a soil well adapted to grain and tobacco. The Atlantic, Mississippi, and Ohio, and the Petersburg and Weldon railroads traverse it. The chief productions in 1870 were 39,869 bushels of wheat, 170,712 of Indian corn, 57,079 of oats, 1,232 tons of hay, and 844,504 lbs. of tobacco. There

were 993 horses, 1,626 milch cows, 1,861 other cattle, and 5,127 swine; 6 flour mills, 3 saw mills, 1 distillery, 17 manufactories of tobacco, 2 of agricultural implements, 8 of carriages and wagons, 4 of cotton goods, 1 of fertilizers, 2 of iron castings, 3 of machinery, and 1 of paper. The largest town is Petersburg. Capital, Dinwiddie Court House.

**DINWIDDIE, Robert**, lieutenant governor of Virginia, born in Scotland about 1690, died at Clifton, England, Aug. 1, 1770. While acting as clerk to a collector of the customs in the British West Indies, he was instrumental in detecting frauds practised by his principal, and as a reward was soon after appointed lieutenant governor of Virginia. He arrived in the colony in 1752, and remained until January, 1758, when he returned to England. Although totally ignorant of military affairs, he discerned the capacity of Washington, whom in 1753 he appointed adjutant general of one of the four military districts of Virginia, and sent as a commissioner to expostulate with the French commander on the Ohio for his aggressions upon British territory. At the outbreak of hostilities with the French and Indians, he called upon the governors of the other provinces to make common cause against them, and convened the house of burgesses of Virginia. Entertaining peculiar notions of the royal prerogative and of his own importance, he was highly incensed at the tardiness of the latter body in voting money for the public defence, and at their refusal to put it under his absolute disposal. In 1754 he suggested to the British board of trade the propriety of taxing the colonies for the purpose of raising funds to carry on the war, and in the succeeding year he was one of the five colonial governors who memorialized the ministry to the same effect. After the defeat of Braddock he continued to busy himself with the military operations on the frontiers, displaying great incapacity, and wearying Washington, then in command of the colonial troops, by frequent exhibitions of ill temper, folly, or caprice. He enjoyed little popularity, and his arrogance brought him into collision with the legislature, while his avarice led him to exact illegal or obsolete fees. At the time of his departure he was charged with having appropriated to his own use £20,000 of public money, which he never satisfactorily accounted for.

**DIOCESE** (Gr. *διοίκησις*, administration), in ancient times, an administrative division of the Roman empire, forming a subdivision of one of the four prefectures, and comprising several provinces; in modern language, the territory governed by a bishop. As early as the time of Cicero we find mention of the *dioceses*, or districts, of Asia Minor. Subsequent to the reorganizations of the empire under Diocletian and Constantine the Great, the dioceses were the East, Egypt, Asia, Pontus, Thrace, Macedonia, Dacia, Illyria, Italy, Africa, Gaul, Spain, and Britain. The East was governed by a count,

Egypt by a prefect, some by proconsuls, and others by vicars. Each province was subdivided into cities (*civitates*), subject to a supreme magistrate residing in the chief city or *metropolis*. When the gospel began to be preached, each city among the Greeks and Latins was governed by magistrates chosen from among the citizens, and sometimes designated as *βουλή*, senate, sometimes as *ordo* or *curia*. Over this governing body presided a superior magistrate called *dictator* or *defensor* of the city. His authority, and that of his brother magistrates, extended over the adjacent territory, made up generally of a number of towns and villages. The first administration of the church was moulded on this civil division. In each *civitas*, or city, with its suburban territory, there was established a corresponding ecclesiastical magistracy, namely, a presiding officer (*episcopus*, bishop), with a senate of priests (*presbyterium*); and his spiritual jurisdiction extended as far as the civil jurisdiction of the city, its circle being called at first *παροικία*, parish, but from the beginning of the 4th century diocese. As each city of the empire had in the towns (*oppida*) of its jurisdiction magistrates subordinate to those of the city itself, so the church in each city came to have ministers subordinate to the bishop in these towns; hence the origin of parishes and parish priests. In like manner the capital city of each province came to have its ecclesiastical metropolitan, who had jurisdiction and superintendence in things spiritual over the bishops of the province. And in some respects corresponding with the office of vicar or *praefectus pratorio* in each civil diocese of the empire, there arose the dignity of patriarch or exarch in the church, whose pre-eminence extended over a number of ecclesiastical provinces. At present, in the Roman Catholic and Greek churches, the word diocese means "the territory attached to each see," whether patriarchal, primatial, metropolitan, or episcopal. Thus, the pope is bishop of the diocese of Rome; the patriarch of Lisbon, of the city of that name and its ecclesiastical territory, forming the diocese of Lisbon; the archbishop of New York, of the city of New York and that portion of the state forming together the archdiocese. In the Protestant Episcopal churches, a diocese is the district ruled by a bishop. In the Evangelical church of Germany, a diocese is a combination of parishes under the care of a superintendent.

**DIOCLETIAN** (DIOCLETIANUS VALERIUS), a Roman emperor, born near Salona in Dalmatia, A. D. 245, died in that town in 313. From his mother, who was called Doclea or Dioclea, from the village in which she lived, he derived the name Docles or Diocles, which he changed on assuming imperial authority to Diocletianus, taking at the same time the patrician name of Valerius. His parents were of the humble class; but his abilities secured his rapid promotion in the army, which he entered at an early age, and his personal pop-

ularity with the troops gave him the greatest influence. He held important positions under Probus and Aurelian, and served under Carus in the expedition against Persia, which was suddenly terminated by that emperor's death in his camp on the banks of the Tigris, in 284. When, during the retreat that followed, Numerian, the son of Carus, was assassinated, the soldiers unanimously chose Diocletian as his successor. But he was obliged to contest his position with Carinus, brother of Numerian, who was recognized as emperor in Europe. The armies of the hostile sovereigns met near Margum, not far from the Danube in Mœsia, where the battle itself was decided against Diocletian; but Carinus, eagerly following the flying enemy, was killed by one of his own officers, and his army readily acknowledged Diocletian as his successor. He was installed as emperor with great ceremony at Nicomedia. But affairs were still in the greatest confusion, and he determined to associate with himself a colleague in the supreme dominion, and fixed his choice on Maximian, his old companion in arms, a rough barbarian, whom he invested with the imperial dignity in 286, and in whom he found a useful assistant and a constant friend. The Roman empire was beset with enemies and torn by factions. The peasants of Gaul rose in arms; Mauritania was in rebellion; Egypt was disturbed by external enemies and internal convulsions; while all along the frontier, from the Euphrates to the Rhine, the barbarians were threatening to destroy the empire by their invasions. Maximian subdued the Bagaudæ or Gallic peasants, but Diocletian determined to strengthen the empire by raising two more Roman soldiers to the purple, Galerius, son of a Dacian shepherd, and Constantius, surnamed Chlorus, son of a noble Mœsian, and father of Constantine the Great. These two princes in 292 received the title of Cæsar, and having repudiated their wives, Galerius married the daughter of Diocletian, and Constantius the stepdaughter of Maximian. Britain, Gaul, and Spain were assigned to Constantius; Galerius received the Illyrian and Danubian provinces; Italy and Africa, with Sicily and the islands of the Tyrrhenian sea, were held by Maximian; while Diocletian, the head of all, retained under his own dominion Thrace, Egypt, and the provinces of Asia, and established his capital at Nicomedia. By this arrangement, on the death of either of the Augusti, as Maximian and Diocletian were styled, the Cæsar who had been associated with him was to be his successor, and another Cæsar was to be appointed. These four princes, it was thought, would hold one another in check, so that no one of them would be able to attain to uncontrolled power. The plan was for a time successful. Maximian subdued the rebellious provinces of western Africa; Diocletian reduced and secured Egypt; Galerius not only, under the superintendence of his father-in-law, compelled the Persians to make

a treaty which secured the frontiers of that part of the empire for 40 years, but also vigilantly guarded the Danubian frontier; while Constantius invaded Britain, which for several years had been detached from the rest of the empire under the rule of Carausius, and restored that island to the control of the Roman emperors. After a prosperous reign of about 21 years, Diocletian, moved by his infirm health, or, as some writers have said, by the persuasions or menaces of his son-in-law Galerius, voluntarily resigned the throne in 305, and retired to Salona in his native country, where he passed the remaining eight years of his life in retirement. Maximian, according to a previous agreement, abdicated at the same time, but was not contented in a private station, and a few years later wrote to his former colleague, proposing to him to resume the reins of government. The reply of Diocletian has become celebrated. "Would you could see," he said, "the cabbages planted by my hand at Salona; you would then never think of urging such an attempt."—Diocletian struck a severe blow at the waning influence of the senate by the removal of his court from Rome to Nicomedia, reduced the numbers and the importance of the prætorian guards, divided the provinces so as to lessen the power of the provincial governors, and increased the dignity and ceremony with which the emperor was surrounded. He is censured for permitting the persecution of the Christians; but it must be remembered that the greater part of these persecutions took place after Diocletian had resigned his authority. The history of the reign of Diocletian is exceedingly confused, and only the principal events given above can be assumed to be accurate. Authorities differ widely in their account of many of the details. The year 284, the period of Diocletian's accession, was made by the ecclesiastical writers the beginning of an era called "the era of Diocletian;" a chronological form often employed in early theological works.

**DIODATI, Domenico**, an Italian archæologist and theologian, born in Naples in 1736, died there in 1801. He wrote several works on ecclesiastical history, and one on the coins of the Italian states; but that by which he became widely known is entitled *De Christo Græcæ loquente Exercitatio* (Naples, 1767). The theory that Greek was the native language of the Jewish people in the time of Christ is advocated in this work with remarkable subtlety, nice comparison of passages, and a great variety of proofs, both external and internal. The academy della Crusca made him at once one of its associate members, and the empress of Russia sent him a gold medal for his service to the language of the sacred records.

**DIODATI, Giovanni**, a Swiss theologian, born in Geneva in 1576, died there in 1649. His parents, natives of Lucca, had taken refuge in Switzerland from the persecution directed against them on account of their Protestant-

ism. At 21 years he became, on the nomination of Beza, a professor of Hebrew. In 1608 he was made parish minister in the Reformed church, and in 1609 became professor of theology. In 1618-19 Diodati, already noted as a preacher both in France and Switzerland, attended the synod of Dort, where with Theodore Tronchin he represented the church of Geneva, and was one of the six ministers appointed to draw up the articles of faith. In this synod he showed himself a zealous Calvinist, and offended many by his bitterness against the Remonstrant party. He relinquished his office as professor in 1645, and passed the remaining years of his life in retirement. He built the villa Diodati, near Geneva, where he was visited by Milton, and in which Byron resided in 1816. He was considered by many to be the most learned Biblical scholar of his day. Among his works are an Italian version of the Bible (1603; new eds., with notes, 1607 and 1641); a free Italian translation of the New Testament (1608); *Mortis Meditatio Theologica* (1619); *De Fictitiis Pontificiorum Purgatorio* (1619); French translations of Job, Ecclesiastes, and Canticles (1638), of the Psalms (1640), and of the whole Hebrew Bible (1644); also of Fra Paolo's "History of the Council of Trent" (1621); and a great number of other theological and controversial writings.

**DIODON.** See SEA PORCUPINE.

**DIODORUS**, commonly called, from the island of his birth, **DIODORUS SICULUS**, a historian of the time of Cæsar and Augustus, born at Agyrium in Sicily; the precise dates of his birth and death are unknown. He spent 30 years in composing a universal history, and in the preparation of this work he traversed a large portion of Europe and Asia. The first 6 books treated of the times anterior to the Trojan war; the 11 following extended to the death of Alexander the Great; while in the remaining 23 the history was brought down to the time of Julius Cæsar. Of this extensive work, which was styled *Βιβλιοθήκη*, or *Βιβλιοθήκη ιστορικὴ* (library, or historical library), we have now only 15 books entire, and a few fragments of the rest. The first 5 books, containing the ancient history of the eastern nations, the Ethiopians, Egyptians, and Greeks, and the 10 from the 11th to the 20th inclusive, comprising events from the second Persian war, 480 B. C., down to 302, remain entire. Many fragments of the other books are preserved in the works of Photius, and in the *Eclogæ*, or selections, made by order of the emperor Constantine Porphyrogenitus. The *Bibliotheca* is the only authentic work of Diodorus of which we have any knowledge. It is written in the style of annals, in a confused and discordant manner; but the work is valuable as giving us, if not always information of facts, at least of the opinions of men at a period concerning which our knowledge is so exceedingly meagre that the slightest addi-

tion is of great value. The first 5 books are especially prized on this account. Most of the events treated in the other 10 are better told by Thucydides and Xenophon, who are silent, however, upon the Carthaginian wars in Sicily related by Diodorus. The best modern editions of his works are those of Dindorf (6 vols., Leipsic, 1828; 5 vols., 1867-'8), Müller (Paris, 1842-'4), and Bekker (4 vols., Leipsic, 1853-'4). That portion which relates to the successors of Alexander was translated into English by Thomas Stocker (4to, London, 1569). The whole work was translated by Thomas Cogan (fol., London, 1653), and by G. Booth (fol., London, 1700 or 1721; republished, 2 vols. royal 8vo, London, 1814).

**DIOGENES**, a Cynic philosopher, born at Sinope, in Paphlagonia, Asia Minor, about 412 B. C., died near Corinth in 323. His father was a banker, and was condemned for having adulterated the coinage; and whether his son was involved in the same condemnation or not, it is certain that he left his native country and took refuge in Athens. Here he became a disciple of Antisthenes, the founder of the Cynic school of philosophy. The latter was at first unwilling to receive him, driving him rudely from his door, and threatening him with his staff. "Strike," said Diogenes; "you cannot find a stick so hard as to compel me to go away while you speak that which I wish to hear." Diogenes soon gained a reputation superior to that of his master for rough and caustic wit. It is said that one day at Athens the citizens saw him with a lantern in his hand, although it was broad day, apparently searching for something. On being asked what he was seeking, he replied, "A man." He had found children, he said, in Sparta, and women in Athens, but men he had never seen. He used to carry a small cup, but broke it on seeing a boy drink from the hollow of his hand. He slept either under the portico of some building, or in a tub, which, according to some authors, was his ordinary dwelling, and which he carried about with him. The truth of this, however, has been much disputed by both ancient and modern critics. He taught in the streets and public places, speaking with the utmost plainness, often with rudeness, and was altogether insensible to reproaches and insults. His wit was ready and severe. Plato defined man as a two-legged animal without feathers; whereupon Diogenes, having stripped a fowl of its plumage, threw it among the pupils of the great academician, bidding them behold one of Plato's men. Being asked which is the most dangerous animal, he answered: "Of wild animals, the slanderer; of tame, the flatterer." On a voyage to the island of Ægina he was captured by pirates, and afterward sold as a slave. While in the market place, waiting for a purchaser, being asked what he could do, he answered that he knew how to govern men, and bade the crier ask, "Who wants to buy a master?" He was purchased by Xenias, a

Corinthian, who carried him home, and afterward set him at liberty, intrusting to him the education of his children. The rest of his days Diogenes divided between Athens and Corinth, and it was at the latter place that his celebrated but apocryphal interview with Alexander the Great is said to have taken place. The king of Macedon, surprised at the indifference with which he was regarded by the ragged philosopher, who was comfortably basking in the sun before his tub, said to him, "I am Alexander." "And I," was the reply, "am Diogenes." Alexander desired him to ask a favor; but all that the Cynic wished was, that Alexander would not stand between him and the sun. Struck with this extraordinary insensibility to the usual weaknesses of humanity, the Macedonian remarked, "Were I not Alexander, I would be Diogenes." Diogenes loved to display his contempt of the common courtesies of life. Plato was giving a magnificent dinner to some friends, and Diogenes entered unbidden, and stamping with his dirty feet on the carpets, exclaimed, "Thus I trample on the pride of Plato." "But with greater pride, O Diogenes," replied Plato. Surly, independent, a voluntary outcast, he lived on till his 90th year. According to some authors he wrote several works, but nothing has come down to us except some sayings preserved by Diogenes Laërtius, and it is generally believed that he wrote nothing whatever. He did not teach by lectures, but uttered his philosophy in short, pithy sentences, as occasion offered.

**DIODENES OF APOLLONIA**, a Greek philosopher, born at Apollonia in Crete, flourished in the 5th century B. C. Very little is known of his life. He was at Athens probably about 460, and became involved in some trouble there. His philosophical speculations were developed in his work *Περὶ φύσεως*, "On Nature," which was extant in the 6th century. His great object was to find the first principle of the world, and he came to the conclusion that air of various degrees of condensation formed the atmosphere, fire, water, and earth, and out of these everything else was evolved; and he endowed this first principle with a certain intelligence, presiding over the arrangement of the universe, the marks of which are visible in the order and beauty of creation. The brutes, he says, are inferior to man because they inhale an air less pure, holding their heads near the ground. The world, too, he supposed to be animated, and he imagined the stars to be its organs of respiration. The few fragments of Diogenes which have come down to us (in the works of Aristotle, Diogenes Laërtius, and Simplicius) were published by Panzerbeiter (Leipsic, 1830).

**DIODENES LAËRTIUS**, an ancient historian of philosophy, who probably lived about the beginning of the 3d century, though the dates of his birth and death are unknown, and his life has been placed as early as the time of Augustus,

and as late as that of Constantine the Great. He wrote a history of philosophy in Greek, divided into 10 books, and giving an account of the philosophers, anecdotes of their lives, and illustrations of their teachings. He considers Grecian philosophy to have been indigenous, and divides it into two schools: the Ionic, commencing with Anaximander and ending with Clitomachus, Chrysippus, and Theophrastus, and of which the Socratic school forms a part; and the Italian, whose founder is Pythagoras, and whose last master is Epicurus, and which includes Heraclitus, the Eleatics, and the Sceptics. The account of these two schools comprises the whole of the work, with the exception of the first book, which contains the history of the seven wise men of Greece. The work of Diogenes is valuable for information which we could obtain from no other source; but it is ill digested, without critical judgment, and often inaccurate. Diogenes is supposed to have written some other works, among which was a volume of epigrams, but these have been entirely lost. A good edition of his history is that of H. G. Hübner (2 vols. 8vo, Leipsic, 1828-'31). A translation into English was published in 1868 (2 vols. 8vo, London), and there is one by C. D. Yonge in Bohn's "Classical Library."

**DIOMEDES**. I. One of the most famous of the Grecian heroes at the siege of Troy, and after Achilles considered the bravest of all the Greeks. According to Homer, his father Tydeus was one of the leaders in the expedition of the seven against Thebes, and was killed before the walls of that city, while Diomedes was still a boy. Having arrived at the age of manhood, he joined the second expedition against Thebes, and avenged his father's death. With 80 ships he sailed in the great Grecian armament to the siege of Troy, where, besides many victories over heroes of less note, he put Hector and Æneas to flight, and wounded both Venus and Mars. He was also famed for his wisdom in council, and when Agamemnon proposed to abandon the siege, Diomedes declared that he with his friend Sthenelus would remain until Troy should fall. According to later legends, he carried off with Ulysses the palladium from Troy. Of his history after the fall of the city Homer gives no account, but later writers tell us that having returned to Argos and found his wife unfaithful, he abandoned his native country. Traditions differ with regard to his after life. According to some accounts, he went to Ætolia, and afterward returned and gained possession of Argos. Another relates that, in attempting to return to Argos, he was driven by a storm upon the coast of Italy, where he was kindly received by King Daunus, whom he assisted in a war against a neighboring tribe, and whose daughter Enippe he received in marriage. II. A king of the Bistones in Thrace, son of Mars and Cyrene, celebrated for his mares, which he fed upon human flesh. To obtain possession

of these mares was one of the twelve labors of Hercules. The hero slew Diomedes, whose body he gave to the mares, which became tame after eating their master's flesh.

**DION CASSIUS COCCEIANUS**, a historian of Rome, born in Nicæa, Bithynia, about A. D. 155, went to Rome about 180, where he was made senator. He was afterward appointed to many offices of trust by different emperors, and was twice consul. Having become odious to the prætorian guards, because, it is said, of his severe discipline, he obtained permission from the emperor Alexander Severus, in 229, to retire to his native city, where he spent the remainder of his days. His great work was a history of Rome written in Greek, divided into 80 books, and containing an account of the rise and progress of the state from the landing of Æneas in Italy until A. D. 229, giving only a slight sketch of events down to the time of Julius Cæsar, but dwelling with minuteness on the history of later times, and especially on that of the author's own age. Of this work, which is written with clearness, diligence, and general accuracy, but in a faulty style, 19 books (from the 36th to the 54th) remain entire. Fragments of the first 35 have been collected, and there are abridgments of the last 26, as well as of the entire work. One of the best editions is that of Sturz (9 vols. 8vo, Leipsic, 1824-'43). An English translation of Xiphilin's abridgment was published in London in 1704.

**DION CHRYSOSTOMUS** (the golden-mouthed), a Greek rhetorician, born in Prusa, Bithynia, about the middle of the 1st century, died in Rome about 117. In the practice of his art at Rome he incurred the hostility of the emperor Domitian, and in consequence of a decree of the senate he was obliged to flee from Italy. In the habit of a beggar, with Plato's "Phædon" and Demosthenes's "Oration on the Embassy" in his pocket, he wandered through Thrace and the countries bordering on the lower Danube, and on receiving intelligence of the death of Domitian (96) used his influence and his oratorical powers with the army stationed on that frontier in favor of Nerva. It is probable that he returned to Rome on the accession of this emperor, from whom as well as from his successor Trajan he received tokens of marked kindness. He was an essayist rather than an orator, and his writings are distinguished for elegance of style. Of his orations 80 are extant. There is a very good critical edition of them by Reiske (2 vols. 8vo, Leipsic, 1784).

**DION OF SYRACUSE**, a disciple of Plato, celebrated for having overthrown the power of Dionysius the Younger, tyrant of Syracuse, born in that city toward the close of the 5th century B. C., killed in 354 or 353. Under Dionysius the Elder, to whom he was doubly related by marriage, he enjoyed the favor of the court, and amassed great wealth; but when the younger Dionysius succeeded to the throne (367), Dion, whose austere manners were a constant rebuke of the royal debaucheries, fell into

disfavor, and at last was banished from Sicily. He found refuge and a friendly reception in Greece, where he lived for a while in affluence, his income being allowed to reach him. Soon, however, this was cut off, and to complete his disgrace his wife Arete was compelled to marry another man. Dion now resolved to avenge himself and his country at the same time. Having assembled about 800 troops, he sailed from Zacynthus (357), landed in Sicily, and easily obtained possession of Syracuse in the absence of Dionysius. The troops of the tyrant still held the citadel on the neighboring island of Ortygia, whence they made a sally soon after the arrival of Dion, and were repulsed only after a fierce combat, during which Dion himself displayed great courage. He was at first received by the citizens with enthusiasm, and on his entry into the city he proclaimed liberty to Syracuse. But, irritated by his harsh manners, suspecting his designs, and incited by the demagogue Heraclides, the people afterward expelled him and his troops. The Syracusans soon had reason to repent of their conduct, for the soldiers of Dionysius, aware of their dissensions, made a sally, regained part of the city, set fire to the houses, and began a fearful massacre. The banished philosopher was entreated to return, and, marching immediately, after a hard contest he obtained full control of Syracuse. He caused Heraclides to be put to death. This act greatly injured his popularity, already damaged by his repellent and austere manners; a conspiracy was formed against him, and he was assassinated.

**DIONÆA** (*D. muscipula*, Ellis), Venus's fly-trap, an insectivorous plant inhabiting the savannas around Wilmington, N. C., and only found in that district. Audubon's affirmation that he had seen it in Florida of enormous size is not confirmed. It belongs to the same natural order as the droseras, or sundews, the common species of which capture flies as effectually as dionæa, but by a different contrivance. It was discovered by the elder Bartram, sent to Collinson, and well described by Ellis in a short treatise addressed to Linnæus. The brief account given by the latter, which was generally copied till recently, was wrong in stating that the trap opens after an insect it has caught becomes quiet; it does not open until all the soft parts of the insect are extracted. To aid in this, a glairy liquid is secreted from innumerable glands which stud the face of the trap, which after maceration of the captive is reabsorbed. The plan and action of the trap may be gathered from the cut and a few words of description, partly condensed from the account of Dr. M. A. Curtis ("Journal of the Boston Society of Natural History," 1834). The trap, at the apex of the leaf, is fringed with stout bristles on each margin; it is aptly compared to two upper eyelids joined at their bases. On each side are three more delicate bristles, so directed that



an insect can hardly traverse it without touching one of them, when the two sides suddenly close upon the prey, the fringe of the opposite sides interlacing, like the fingers of the two hands clasped together. The sensitiveness resides only in these hair-like processes on the inside, as the leaf may be touched or pressed in any other part without effect. Soon the sides of the trap press down firmly upon the captive (when the fringe separates); the liquid is poured out, and finally absorbed, when the trap opens, and sometimes recovers its activity so as to capture a second insect. Ellis (and probably Bartram) noticed the glands and the fluid, but thought it was a lure for flies. Curtis showed that it appeared only after the capture. Canby lately proved that it was secreted by the leaf, and taken in again; also that bits of meat were similarly digested. Darwin had



*Dionaea muscipula.*

ascertained the same, also that this "gastric juice" had an acid reaction. He has also made the (still unpublished) discovery that either side of the trap may be paralyzed at will by a dexterous incision, indicating the existence in a plant of something corresponding to nerves. Burton Saunderson has shown that in the closing movement the same electrical currents are developed as in muscular contraction.

**DIONYSIUS**, tyrants of Syracuse. **I.** The **Elder**, born in 431 or 430 B. C., died in 367. After completing his education he became a clerk in a public office, which he appears to have left at an early age to enter the army. In the political quarrels of the citizens he took the side of Hermocrates, and was severely wounded in aiding that party leader in his attempt to gain his restoration from exile. He afterward served with merit in the war against the Carthaginians. He availed himself of the general discontent with the conduct of the war to come forward in the popular assembly as the accuser of the unsuccessful Syracusan commanders, who had suffered Agrigentum

and other important cities of Sicily to be taken. He displayed so much vigor, and the condition of Syracuse was so critical, that he obtained a decree for deposing the obnoxious generals, and for appointing others in their stead, and was himself elected among the new officers. He then brought false accusations against his associates, and the people in 405 appointed him sole general, with full powers, and allowed him a body guard. He now began those measures which made him proverbial in antiquity as a tyrant. Concerning himself no longer for the deliverance of Sicily from the Carthaginians, he aimed only to subdue his native city. He induced the Syracusans to double the pay of the soldiers, appointed officers who were in his own interest, and by marrying the daughter of Hermocrates secured the support of the partisans of that leader. As commander-in-chief of the Sicilians, who had concentrated their forces at Gela, he offered battle to the Carthaginians in a manner so unskilful as to make it probable that he did not regret the defeat in which it resulted. He withdrew the inhabitants of Gela and Camarina to Leontini, and left the whole S. W. coast to the Carthaginians. This reverse enabled his enemies to raise a revolt in Syracuse, where he was now looked upon as a manifest traitor. They gained possession of the city, but their plans being disconcerted by the sudden return of Dionysius, they were driven out, though not until his wife had fallen a victim to their cruelty. The Carthaginian generals now besieged Syracuse, but the plague having broken out in their camp, they were satisfied with the immense advantages offered them by Dionysius without storming the place. He was recognized as ruler of Syracuse, and of a district around the city, but was to resign all claim to dominion over the island. He availed himself of the peace to establish his tyranny more firmly; and having fortified the isle of Ortygia, and excluded from it all but his immediate dependants, he built upon it a citadel which might serve as an impregnable asylum. The Carthaginians lost the advantages of the peace through negligence. Syracuse had in six years recovered her strength, and Dionysius undertook the recapture of the cities he had surrendered. The immense preparations which he made form an epoch in ancient military history. His machinists invented engines for throwing missiles, and especially devised the catapult. He also constructed ships having four or five banks of rowers, instead of the old triremes. He gained at first great success, and conquered Motya, the ancient seat of the Carthaginian dominion (396). His fleet, however, was defeated by that of the Carthaginians, which ravaged the northern coast of the island, overpowered Messina and Catania, and laid siege to Syracuse (395). But the plague, or some similar malady, again breaking out in the camp of the enemy, proved the safety of the city. Nearly the whole Carthaginian army was lost

by the pestilence, and the remainder purchased from Dionysius the privilege of a free departure. In the treaty which followed, the restrictions which had been imposed by the last treaty upon the government of Syracuse were removed. Dionysius carried on also a third and fourth war with Carthage, the results of which seem to have been only to reestablish the terms of the former peace. The intervals between these wars were harassed by the revolts of his subjects, which he avenged with cruelties. The frequent attempts upon his life made him suspicious. He durst not trust even his relatives, and his body guard was formed of foreigners. His palace was surrounded by a ditch, crossed by a drawbridge, and when he harangued the people it was from the top of a lofty tower. He built the terrible prison of the *loutumia*, cut deep into the solid rock; another of his prisons was so arranged that every word spoken within it was echoed into his chamber, and he is said to have passed entire days listening to the complaints of his victims. But tradition, in making of Dionysius the type of cruelty, has doubtless transmitted many unauthenticated stories concerning him. Dionysius was long engaged in ambitious projects against the Greek cities of southern Italy. He formed an alliance with the Locrians, and after suffering some reverses besieged and conquered Rhegium (387). Italy was now open to him, and he sought by establishing colonies upon the Adriatic to secure for himself a way into Greece. Already his name was known in the Peloponnesus, where he had contracted an alliance with the Lacedæmonians. He was now the recognized master of southern Italy, interfered in the affairs of the Illyrians, sent an army into Epirus, and received an offer of friendship from the Gauls, who had burned Rome. His settlements upon the Adriatic increased his wealth and strengthened his power, but they were his last great undertakings, and henceforth he disappears from history. His reign, which lasted 38 years, became milder toward its close. He left an immense military force and a powerful empire; and though he had governed as a tyrant, the old republican forms remained. Dionysius had a passion for literature, and wrote lyrics and tragedies, none of which have been preserved.

**H. The Younger**, son and successor of the preceding, born early in the 4th century B. C. On his accession to power in 367 he was entirely unused to public affairs, and devoted to pleasure. He hastened to conclude a peace with the Carthaginians, abandoned his father's projects of foreign settlements and power, and gave himself up to luxury and sensuality. His brother-in-law Dion undertook to excite him to a noble career. He conversed with him upon the doctrines of Plato, and through his influence that philosopher was invited to revisit the court of Syracuse, at which under the elder Dionysius he had met with very unfavorable treatment. Plato proposed an amendment

to the constitution, changing the government from nominal democracy and real despotism to a limited popular authority, in which all the members of the ruling family should form a college of princes; but the monarch rejected this proposal. Soon afterward he took up his residence in Locri, and gained some advantages against the Lucanians; but the wild orgies to which he surrendered himself drew upon him the contempt both of his subjects and of foreigners. With a small band of exiles, and with two vessels laden with arms, Dion landed in Sicily in 357, and was joined by thousands as he marched toward Syracuse. Dionysius, hearing of his coming, instantly returned from Locri, but his troops were defeated, and he was obliged to retreat to the citadel; and finding it impossible to retain his power, he collected his most valuable property and fled to Italy, leaving the citadel in possession of his son and friends. He returned to Locri, where he was kindly received; but he took advantage of the good will of the people to make himself tyrant of their city, and treat them with the greatest cruelty. He held Locri thus for several years; but in 346 he availed himself of internal dissensions in Syracuse to recover his power in his old capital, and continued to reign there during the next three years. The former Syracusan empire was now, however, in fragments; and even the garrison which defended the tyrant in the citadel was rebellious. Timoleon, the Corinthian, landed in Sicily, and marched against Syracuse, and Dionysius consented to an arrangement, by which he was allowed to depart in safety to Corinth (343). He passed the remainder of his life with low associates, supporting himself, according to various traditions, as schoolmaster, actor, and mendicant priest of Cybele.

**DIONYSIUS, or Denis** (Port. DINIZ), king of Portugal, born in Lisbon, Oct. 9, 1261, died at Santarem, Jan. 7, 1325. He was the son of Alfonso III., whom he succeeded Feb. 16, 1279. He associated with himself in the government his mother Beatrix de Guzman, but soon quarrelled with her because she favored the cause of his younger brother Alfonso, who aspired to the throne. Beatrix retired to the court of her father, Alfonso X. of Castile and Leon, and Dionysius strengthened his power by marrying in 1283 Elizabeth of Aragon, afterward canonized as St. Elizabeth. He at once set about making reforms in his kingdom. He restricted the power of the clergy, reformed the administration of civil and criminal justice, restrained the arrogance of the nobles, promoted industry and commerce, and augmented the public revenues by a wise administration. He visited all the provinces that had been laid waste by the wars of his predecessors, built and fortified over 40 cities and towns, planted the forest of Leiria, which two centuries after furnished the timber for the ships which gave Portugal her maritime ascendancy, opened and worked the mines in his

kingdom, and founded the university of Lisbon (now of Coimbra, the only one in Portugal). He forbade the use of the Latin language in public documents, caused many works to be translated into Portuguese, and cultivated poetry himself with some success. So many and so patriotic were his labors that he acquired the title of father of his country. He was also known as the protector of letters, the just, the liberal, and the laborer. His latter years were embittered by the unfilial conduct of his illegitimate but much favored son Affonso, who conspired against him, and by troubles with the church. The military order of Christ was founded by Dionysius in 1319.

**DIONYSIUS OF ALEXANDRIA**, a saint and bishop of the church, born in Alexandria, Egypt, late in the 2d century, died there A. D. 265. He was of a noble and wealthy pagan family, but in the course of his early philosophical studies his attention was turned to the Christian sacred writings, especially the epistles of Paul, and he became a convert. He left the heathen schools, became a pupil of Origen, was ordained priest, and about 232 was chosen to succeed Heraclas as chief of the Alexandrian school of theology. About 247 he was raised to the office of bishop, made vacant by the death of Heraclas. Shortly after this violent persecutions broke out against the Christians. The populace of Alexandria had been stirred up against them by a heathen prophet, and the edict of Decius, which reached that city in 250, put arms in the hands of their enraged enemies. Dionysius, who had taken an active part in preparing the Christians for the coming trial, was arrested, sent to be put to death, rescued by a band of peasants, and remained concealed more than a year in the Libyan desert, sending continual messages meanwhile to his brethren in the city. In the persecution under Valerian in 257, Dionysius was again exiled from his see. After his restoration (260), brought about by an edict of Gallienus favorable to the Christians, he was more than once called to mediate on occasions of public strife. —The writings of Dionysius were numerous, but most of them have been lost. They were mainly controversial. He wrote two books refuting the theory of Nepos, of the millennial earthly reign of the Saviour. In opposition to Sabellius, who denied the distinct personality of the members of the Trinity, he wrote several books and epistles, caused the heresy to be condemned by a council, and insisted upon the distinction between the Son and the Father so strongly that it brought upon him the charge of denying the divinity of Christ, against which he defended himself. He also defended the doctrine of the divinity of the Holy Spirit. In opposition to Paul of Samosata, Dionysius maintained the consubstantial nature of the Son and the Father. The fragments of his writings were collected by Simon de Magistris (folio, Rome, 1796), and are also contained in the *Bibliotheca Patrum*, vol. iii.

**DIONYSIUS THE AREOPAGITE**, an Athenian, who was one of the council of the Areopagus when St. Paul preached to the Athenians. He is said to have studied first at Athens, and afterward at Heliopolis in Egypt. There is a legend that when he observed in Egypt the darkening of the sun during the crucifixion of Jesus Christ, he exclaimed, "Either God himself is suffering, or he is sympathizing with some one who is suffering." He was converted by the preaching of Paul, about A. D. 50, is mentioned in the Acts of the Apostles (xvii. 34), and was probably the first bishop of Athens, having been appointed to that office, it is said, by St. Paul himself. It is also believed that he suffered martyrdom, but in what year is not known. It is not certain that he ever wrote anything, but his name has been given to four theological treatises, imbued with the mystical doctrines of the Alexandrian Platonism. These works, which are first mentioned in the 6th century, contain allusions to facts and quotations from authors subsequent to the apostolic age, and were probably written by some Neo-Platonic Christian of the 4th or 5th century.

**DIONYSIUS EXIGUUS** (the Little, so named from his small stature), a Roman monk of the 6th century. He was a native of Scythia, but became abbot of a monastery in Rome, where he died about 550, during the reign of Justinian. He gave to the western church the first regular collection of ecclesiastical laws, comprising the canons of the apostles and of several councils, and the decrees of some of the popes. But his chronological labors have given him greater celebrity. He is reputed the founder of the era which for more than ten centuries has been observed by Christian nations. Before him the Christian era had been calculated from the death of Christ; he first fixed the year of the incarnation in the 754th year of Rome, and this, at least after the 8th century, was universally adopted as the commencement of the era. (See CHRONOLOGY.)

**DIONYSIUS OF HALICARNASSUS**, a Greek historian and rhetorician, born in Halicarnassus, Caria, about 70, died in Rome about 7 B. C., having removed there about 29. Of his life we know almost nothing, excepting that it was for the most part spent in literary labor. He wrote many rhetorical and critical essays, and shortly before his death published the greatest of his works, entitled *Ῥωμαϊκὴ Ἀρχαιολογία*, or "Roman Antiquities." It was in 20 books, and contained the history of Rome from the earliest mythical times to the era of the Punic wars, where the history of Polybius begins. Only the first 11 books remain, which end with the year 441. Several fragments and extracts from the last nine books have been preserved in the collections made by command of the emperor Constantine Porphyrogenitus in the 10th century. The best editions of his works are those of Hudson (Oxford, 1704) and Reiske (Leipsic, 1774-'6). Such of his rhetor-

ical compositions as have been preserved have been published separately by Gross and by Westermann. There is an English translation of the "Roman Antiquities," by Edward Spelman (4 vols. 4to, London, 1758).

**DIONYSUS.** See **BACCHUS**.

**DIOPHANTUS OF ALEXANDRIA**, the only Greek writer on algebra, first mentioned by John, patriarch of Jerusalem, in the 8th century, unless he be identical with the astronomer Diophantus, on whose work Hypatia is said by Suidas to have written a commentary. There are no more definite indications of his era. When his MSS. came to light in the 16th century, thirteen books of his *Ἀριθμητικά* were announced, only six of which have been produced. Another treatise by him, *Περὶ τῶν Ἀριθμῶν Πολυγώνων* ("On Polygonal Numbers"), is extant. These books contain a system of reasoning on numbers with the use of general symbols, and are therefore algebraical treatises, though the demonstrations are written out at length in common language. The term Diophantine was applied by some modern mathematicians to the peculiar analysis employed in investigating the theory of numbers. The similarity of the Diophantine and Hindoo algebra renders it probable that they had a common origin, or that one was derived from the other. The best edition of his works is that of Fermat, in Greek and Latin (Toulouse, 1670). They were translated into German by Schulz (Berlin, 1821). The six books of the "Arithmetic" were translated into French by Stévin and Girard (Paris, 1625).

**DIOPTRICS.** See **OPTICS**.

**DIOSCORIDES, Pedanius or Pedanius**, a medical and botanical writer of the 1st or 2d century A. D., probably a native of Anazarbus in Cilicia. He made collections of plants in Asia Minor, Greece, Italy, and Gaul, and wrote a treatise in five books on materia medica (*Περὶ Ἰατρικῆς*), a work which enjoyed the highest reputation until the 17th century. It is now chiefly valuable as illustrating the opinions of ancient physicians and giving some idea of their attainments in natural history. It has been translated into Arabic, Italian, Spanish, French, and German, and many editions of it have been published in Latin and Greek.

**DIOSCURI.** See **CASTOR AND POLLUX**.

**DIPHThERIA** (Gr. *διφθέρρα*, membrane), the name of a disease which has heretofore received a variety of appellations, such as *ulcus Egyptianum vel Syriacum*, *cynanche maligna*, *angina maligna*, *angina gangrenosa*, *morbus suffocans vel strangulatorius*, *garrottillo*, *angina suffocativa*, malignant sore throat, epidemic croup, &c. The term diphtherite was applied to it by Bretonneau in 1821, whence originated the name diphtheria which is now in common use, relating to the formation of a false membrane in the throat and in other situations, analogous to that which characterizes the disease called, among other names, diphtheritic laryngitis, or true croup. (See **CROUP**.)

Recent microscopical observations, however, appear to show points of difference between the pseudo-membranous morbid product in the two diseases. In diphtheria the false membrane, accompanying inflammation, appears almost invariably in the fauces or throat, and in many cases it is limited to this situation. It may extend more or less over the mucous surface within the mouth and nostrils. It is not infrequently produced within the windpipe, giving rise to all the symptoms of true croup, and generally proving fatal. Mucous surfaces elsewhere are in some cases the seat of this peculiar form of inflammation; namely, in the eyes, the ears, the organs of generation, &c. A similar false membrane is produced in some cases on the skin, in situations where there may be either wounds, abrasions, or sores. The local affections thus characterized cannot be said to constitute the disease, but they are to be considered as the manifestations of a morbid condition of the system, probably involving special blood changes, the essential nature of which is at present unknown. In other words, diphtheria belongs among the diseases which are distinguished nosologically as general or constitutional. The disease rarely occurs except as an epidemic. Epidemic diphtheria has occurred in all countries, but in the United States only occasional sporadic cases were observed during the first half of the present century. Since about 1856, however, there have been repeated epidemics in different parts of the country. Whether it be one of the communicable diseases, that is, diffused by contagion or infection, is an open question. Persons between 3 and 12 years of age are most apt to be affected with it, but no period of life is exempt from a liability to it. The false membranes are found frequently to contain a parasitic fungus, the spores and sporules of a cryptogamic plant; and the idea has been entertained that the disease is due to the presence of these. It seems, however, more reasonable to suppose that they are merely incidental to the local affection, the morbid products furnishing only a proper nidus or soil for their growth and reproduction. Different epidemics differ much in the rate of mortality. The disease is sometimes mild, the local manifestation being confined to the throat, and the constitutional symptoms slight. In other cases it has a degree of violence and a fatal tendency which entitles it to be classed among the malignant diseases. Death sometimes takes place within 48 hours after the attack. The degree and extent of local manifestations are in general commensurate with the severity and danger. If the larynx becomes affected, the chances of recovery are very few. Frequent vomiting, diarrhœa, hæmorrhage from the nostrils or elsewhere, frequency and feebleness of the pulse, convulsions, delirium, and coma are symptoms which denote great danger. If the larynx is affected, death may take place from suffocation. In the fatal cases in which the

larynx escapes, the immediate cause of death is exhaustion. Paralysis frequently occurs as a sequel. The muscles of the throat are those most likely to become more or less paralyzed, rendering deglutition difficult and sometimes impossible. With or without paralysis in this situation, the muscles of the lower limbs may be paralyzed, or the muscles of an upper and a lower limb on one side. Occasionally the muscles of both the upper and lower limbs are affected. Vision may be impaired by paralysis of the external rectus muscle, causing strabismus or squinting; and not infrequently far-sightedness, or more rarely near-sightedness, takes place; and amaurosis occurs in some cases. The other special senses, hearing, taste, and smell, are sometimes affected. These varied paralytic affections generally occur within a few weeks after convalescence from the diphtheria. They are as likely to follow in cases where the disease was mild as where it was severe. As a rule complete recovery takes place, showing that the paralysis does not proceed from structural changes. The disease, when paralysis does not follow, generally leaves the patient feeble and anæmic for a considerable period. Sudden death from syncope has repeatedly occurred after convalescence had been declared, as a consequence of some muscular effort; hence the importance of enjoining quietude until the strength is in some measure restored.—The treatment has been supposed to embrace, as a highly important measure, cauterizing applications to the throat and to the local affection in other situations; the objects being to destroy or modify the special character of the inflammation, to limit its extension, and prevent the absorption of septic matter. Those who consider the efficient cause of the peculiar inflammation to be the presence of cryptogamic formations, are of course led to attach importance to applications which destroy vegetable life. For the most part, however, in this country, physicians have abandoned severe topical measures, limiting themselves to antiseptic and soothing applications. Clinical experiences seem to establish the propriety of this plan. The chief objects in the treatment are to palliate symptoms, and support the powers of life by the judicious employment of tonic remedies, conjoined with alimation and alcoholic stimulants. The latter are in some cases given in large quantity without inducing their excitant effects; and there is reason to believe that they are sometimes the means of saving life. In the cases in which the larynx becomes affected, the measures are indicated which belong to the treatment of true croup, and tracheotomy is to be resorted to if necessary to avert death from suffocation. The prospect of success from this operation is extremely small; yet, as it undoubtedly sometimes rescues a patient from impending death, it is the duty of the physician not to withhold the chances of life, however small, which tracheotomy affords.

**DIPLOMATICS** (Gr. *διπλωμα*, a doubling; hence anything folded double, as a written document), the science of the knowledge of ancient documents, and especially of their age and authenticity. The charters of grants from sovereigns to individuals and corporations were formerly called diplomas, and the word is applied to all letters, documents, and pieces of writing of a public nature that have come down to us from the middle ages and the subsequent centuries. The ancient public documents of the Greeks and Romans have perished, except such as were inscribed on stone or metal. But a vast mass of manuscripts of the middle ages exists in Europe, whose dates and authenticity can only be settled by careful and skilful investigation. The quality of the parchment or paper and of the ink, and the style of the handwriting, are the means chiefly relied upon to determine the age of the document. Formerly ink was made of soot, and red ink made of vermilion was sometimes used. Those who apply themselves to the study of diplomatics can easily distinguish the ink and the parchment and paper of one epoch from those of another. The variations in handwriting are also so great that by the character alone it is possible to pronounce within 40 or 50 years when any diploma was written. In Europe the study of diplomatics has been much cultivated. The standard book of reference on the subject is the *Nouveau traité de diplomatique, par deux Bénédictins* (6 vols. 4to, Paris, 1750).

**DIPPEL, Johann Konrad**, a German mystic and rationalist, born at the castle of Frankenstein, Hesse, Aug. 10, 1673, died at Berleburg, April 25, 1734. He was the son of a clergyman, and at an early age showed a strong interest in religious matters. He studied theology at Giessen and philosophy at Wittenberg, and went subsequently to Strasburg, where he led a disorderly life, and had to leave the city, it is said, on account of being implicated in a bloody affray. He frequently appeared as a preacher, and also as a lecturer on astrology and chiromancy, and published in 1697 a pamphlet entitled *Orthodoxia Orthodoxorum*, and in 1698 another, called *Papismus Protestantium vapulans*, in which he attacked the orthodox party, rejecting the doctrines of the atonement and of the efficacy of the sacraments. He was consequently obliged to lead a wandering life to avoid prosecution. Having squandered his property in experiments in alchemy, he went to Leyden, obtained the degree of doctor of medicine, and began to practise as a physician. He published subsequently some other pamphlets, one of which, entitled *Alea Belli Muselmanici* (Amsterdam, 1711), caused his exile from Holland. He went to Denmark, where he continued to declaim against the clergy and the churches, for which he was arrested and imprisoned. After his release he went to Sweden, where he practised as a physician with considerable success; but having pub-

lished a pamphlet regarded as heretical, he was expelled from the country and soon afterward died. He acquired much scientific knowledge and made some valuable discoveries. The main point of his doctrine was that Christianity consists solely in the practice of virtue, of self-denial, and love for mankind. He published his writings under the name of Christianus Democritus (collected under the title of *Eröffneter Weg zum Frieden mit Gott und allen Creaturen*, Amsterdam, 1709; enlarged ed., Berleburg, 1743). He attracted much notice in his day in Sweden and Germany, and is frequently mentioned by Swedenborg in his "Spiritual Diary." His biography was written by Ackermann (Leipsic, 1781), and Buchner has given a memoir of him in the *Historisches Taschenbuch* for 1858.

**DIPTERA** (Gr. *δις*, twice, and *πτερόν*, wing), an order of insects, containing the fly, mosquito, &c., characterized by two wings, two knobbed threads (*halteres*, balancers or poisers) behind the wings, and a horny or fleshy proboscis. They undergo a complete transformation; the larvæ, usually called maggots,

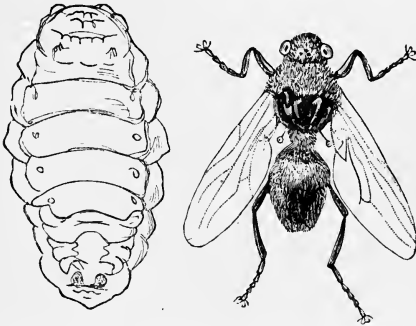

Larva and Imago of the Bot Fly of the Ox (*Hypoderma bovis*).

have no feet, and have the breathing holes generally in the posterior part of the body; the pupæ or nymphs are either incased in the dry skin of the larvæ, or naked, showing the wings and legs free and unconfined. The head is large, globular, connected with the body by a very slender neck, and is capable of a considerable pivot-like motion; the greater part, especially in the males, is occupied by the brilliant compound eyes, the single ocelli, when they exist, being on the top of the head. Under the head is the proboscis or sucker, which in some kinds can be drawn up and concealed in the mouth; it consists of a long channel, ending in two fleshy lips, and enclosing on its upper side from two to six fine bristles, sharp as needles, and making the punctures so familiarly known in the case of mosquito bites; as this apparatus takes the place of the jaws of other insects, these wounds may properly be called bites. The saliva which flows into the wounds causes the well known swelling and itching. The sheath serves to main-

tain the lancets in position, and the latter having made their punctures form a groove along which the vegetable or animal fluids rise by the suction power of the insect and by capillary attraction. In the flies which only lap their food the proboscis is large and fleshy. The antennæ in the gnats are long and many-jointed, in the flies short and thick, at the base of the proboscis. The wings are generally horizontal and delicate, with many simple veins; the posterior wings are metamorphosed into the balancers or poisers. Some entomologists, as Latreille, think the poisers do not correspond to posterior wings, but are vesicular appendages connected with the posterior respiratory tracheæ of the chest. Just behind the wing joints, and in front of the poisers, are two small convex scales, opening and shutting with the wings, and called winglets. The thorax is often the hardest part of the insect, composed principally of the mesothorax. The abdomen is not always united to the thorax by the whole of its posterior diameter, and in many females ends in a retractile jointed ovipositor. The legs, six in number, are usually long and slender, with five articulate tarsi and two claws at the end, besides two or three little cushion-like expansions, by means of which they are able to ascend the smoothest surfaces and to walk with the back downward with perfect security. According to Marcel de Serres, the dorsal vessel (the heart) in diptera is narrow and its pulsations are frequent. Respiration in the adult is carried on by vesicular and tubular tracheæ. The nervous system consists of an aggregate of cerebral ganglia, and in some of nine other ganglia, three in the thorax and six in the abdomen, connected by longitudinal simple commissures or cords; the larvæ have usually one more pair of ganglia than the adults, and have the commissures often double. The proboscis being the transformed under lip, often geniculate, the perforating bristles may be regarded as maxilla, mandibles, and tongue. In those larvæ which have a distinct head, as in the mosquito, the jaws are arranged for mastication, though some of the pieces are wanting; but in the acephalous maggots the mouth is suctional. Communicating with the gullet is a thin-walled vesicle, the sucking stomach, in which the fluids swallowed are temporarily deposited; the stomach proper is long and narrow, and makes many convolutions in the abdomen. The end of the intestine is short, muscular, and pyriform. The uriferous vessels are long, and generally four in number, opening into the lower extremity of the stomach; the ovaries consist usually of many short three- or four-chambered tubes, terminating in a short or a convoluted oviduct; the testicles are two, simple, and generally oval or pyriform, with long vasa deferentia ending in the ejaculatory duct in common with two simple accessory mucous glands, and with horny valves enveloping the projecting copulatory organ. The larvæ or maggots are

without legs, generally whitish, and vary exceedingly in form and habits. The larvæ of the mosquito are aquatic, breathing with the head downward through the tubular tail surrounded with feather-like appendages, and the pupæ tumble about in water by means of two oval fins. These larvæ, and those of most flies which have four or six bristles in the proboscis, have a distinct horny head, and cast their skins to become pupæ, which are generally brownish; many have thorns and prickles on the body by which they work their way out of their coverings; a few cover themselves with silken webs and spin cocoons. The larvæ of other flies, with a soft retractile head, living by suction, increase rapidly in size, and change their form without casting off their skins, which shorten and harden, forming a case within which the larva changes into a pupa, which comes forth a fly by forcing off one end of the case. Though this order contains the bloodthirsty mosquito, the disgusting flesh fly, and many insects depositing their eggs in the bodies of living animals, it is most useful, supplying food to insectivorous birds, and consuming decomposing animal and vegetable substances. Their life in the perfect state is short, very few surviving the rigor of winter.—Among the genera with many-jointed antennæ the following are the most interesting and best known: *Culex* (Linn.) contains the well known gnats and mosquitoes, whose larvæ and pupæ are so common in stagnant water, called wigglers and tumblers, and whose adult females pierce with their lancets and annoy by their nocturnal hum the human race from Lapland to the tropics; the best known species are the *C. pipiens* of Europe, and the *C. Americanus* of this country, which is probably distinct. The genus *cecidomyia* (Latr.) includes many species interesting to the agriculturist, as the Hessian fly (*C. destructor*, Say), the wheat fly (*C. tritici*, Kirby), and the willow-gall fly (*C. salicis*, Fitch), injurious in the larva state. The genus *tipula* (Linn.), especially *T. oleracea* (Linn.), commonly known in England by the name of Harry Long-legs, is noted for its depredations in the larva condition on the tender roots of meadow plants. In the genus *simulium* (Latr.) are the black fly and the midges of the northern parts of America. The black fly (*S. molestum*, Harris) fills the air during the month of June in Canada and the northern states; it flies in the daytime, and is so savage that every bite draws blood, sometimes accompanied by considerable irritation; it is black, with transparent wings, and about  $\frac{1}{10}$  of an inch long. After continuing through June, it is followed by another species (*S. no-civum*, Harris), called "no-see-'em" by the Indians of Maine from their minuteness; they come forth toward evening, creep under any kind of garment, and produce a sharp, fiery pain without drawing blood; they are very troublesome in July and August. Among those

with few joints in the antennæ is the genus *tabanus* (Linn.), which contains the large horse flies, as *T. bovinus* (Linn.), dark brown, an inch long, common in Europe, where there are more than 40 other species. The most common American species is *T. atratus* (Fabr.), black with a whitish bloom on the back; the eyes are very large, shining black, with two jet-black bands across them; it is about an inch long, with an expanse of wings of two inches. The orange-belted horse fly (*T. cinctus*, Fabr.) is smaller and less common, black, with the first three rings of the body orange. A smaller species is *T. lineola* (Fabr.), with a whitish line along the top of the hind body. In summer these flies are very troublesome to cattle and horses, being able to pierce through the thickest hide with their six-armed proboscis; a strong decoction of walnut leaves, applied as a wash, is said to keep them off. The golden-eyed forest flies (*chrysops*, Meig.) are known by their brilliant spotted eyes and their banded wings; smaller than horse flies, they resemble them in their habits, frequenting woods and thickets in July and August; some are wholly black, others striped with black and yellow. The bee fly (*bombylus equalis*, Fabr.) flies with great swiftness through sunny paths in the woods, hovering over flowers and sucking their honey, like humming birds; it is about three eighths of an inch long, shaped like a humble-bee, and covered with yellowish hairs; the expanse of the wings is about an inch; they are divided longitudinally into two equal parts by the colors, the outer half being dark brown and the inner colorless. Among the flies which prey on other insects, seizing them on the wing or on plants, is the genus *midas* (Latr.), of which the orange-banded species (*M. flatus*, Fabr.) is sometimes  $1\frac{1}{4}$  in. long and  $2\frac{1}{4}$  in. in expanse of wings; the general color is black; it frequents the woods in July and August, where it may be often seen flying or basking in the sun; the larva is a cylindrical maggot, growing to the length of 2 in.; the pupa measures  $1\frac{1}{2}$  in. in length, is brown, with forked tail, eight thorns on the fore part of the body, and numerous sharp teeth on the edges of the abdominal rings; it pushes itself half out of its hole when the fly is about to come forth. The genera *laphria* (Fabr.) and *asilus* (Linn.) are also predaceous in the winged state; in the former the antennæ are blunt at the end, in the latter slender-pointed; the former resemble large humblebees in their thick and heavy bodies and legs. In the larva state these asilians live in the ground, where they do much mischief to the roots of plants. The soldier flies (*stratiomydæ*) have two spines on the hinder part of the thorax; the proboscis contains only four bristles, and ends with fleshy lips adapted for sucking vegetable juices; they are fond of wet places, and their larvæ live in stagnant pools, some thrusting their breathing tube out of the water; they undergo transformation within the hardened larval skin. The

genus *stratiomys* (Geoff.) has a broad oval body, of a dark color, with yellow markings on each side, and the antennæ somewhat spindle-shaped. The genus *sargus* (Fabr.) is said to have no spines on the thorax, a slender body, of a brilliant grass-green, about half an inch long, with a bristle on the end of the antennæ. These insects delight in sunny weather, being dull and inactive in cloudy days; the larvæ are found in dung and rich mould. The *syrrhida* have also a fleshy proboscis, and live on the honey of flowers; they resemble bees, wasps, and hornets in shape and color, and sometimes lay their eggs in the nests of these insects; others drop their ova among plant lice, which the young eagerly feed upon. The larvæ of the genus *helophilus* (Meig.) were named by Réaumur rat-tailed maggots, from the great length of their tubular tails, which serve as respiratory organs; the experiments of Réaumur show that while the insect lies concealed in mud, its respiratory tube may reach five inches to the surface of the water; it seems to be composed of two portions, which slide one into the other like the joints of a telescope. Some of the larvæ of this family live in rotten wood. The family *conopidæ* resemble slender-bodied wasps; the antennæ are long and three-jointed; the proboscis is long, slender, and geniculate. The genus *conops* (Linn.) is generally black, and about half an inch long; more than 20 species are described, usually found on flowers in June and July, but not in large numbers; they deposit their eggs in the larvæ and the perfect insects of the humblebee, in whose bodies their young undergo metamorphosis. The common stable fly belongs to the genus *stomoxys* (Fabr.); the flesh fly to *sarcophaga* (Meig.); the house fly and the meat fly to *musca* (Linn.); the flower flies to *anthomyia* (Meig.); the cheese fly to *piophilæ* (Fallen.); the dung fly to *scatophaga* (Meig.); the fruit and gall flies to *ortalis* (Fallen.) and *tephritis* (Latr.). (See FLY.) The gadflies or bot flies, comprising the genera *æstrus* (Linn.) and *gasterophilus* (Leach), affect respectively the ox and the horse. (See GADFLY.) Various winged and wingless ticks infest the horse, sheep, and birds, belonging to the order of *diptera*, but forming with the spider flies the order *homaoptera* of Leach and the English entomologists; they include the genera *hippobosca* (Linn.), *melophagus* (Latr.), and *ornithomyia* (Latr.). (See TICK.) The *pulicidæ*, or fleas, are wingless diptera, with hard, compressed bodies, a sucker-like mouth, and hind legs formed for leaping; they live principally upon the bodies of other animals. (See EMIZOA.)—At the end of this order may be mentioned the genus *nycteriobia* (Latr.), the spider fly, a wingless insect resembling a spider; the small head seems a mere tubercle on the anterior and dorsal portion of the thorax; the eyes are like minute grains; the thorax is semicircular; the antennæ are extremely short, inserted close together, and immediately in front of the eyes. These

flies nestle in the hair of bats, among which they move with great rapidity; according to Col. Montagu, when they suck the blood of bats they are obliged to place themselves on their backs on account of the dorsal position of the head. This last division of the diptera is not produced from eggs deposited in the usual manner, but the larva is hatched and developed within the body of the mother, and is not born till it arrives at the state of pupa; hence these genera have been called *pupipara* by Latreille. The pupa when born is nearly as large as the parent, enclosed in a cocoon, the altered skin of the larva at first soft and white, but soon growing hard and brown; it is notched at one end, where the mature insect escapes. The genera of diptera make up for their small size by their countless swarms.

**DIPTYCHS** (Gr. *δίπτυχα*, from *δίς*, twice, and *πτύσσειν*, to fold), tablets anciently used for civil and ecclesiastical purposes. Among the Romans and Greeks, the term at the commencement of the Christian era designated two tablets united by a hinge, and used as a note book. Even when several tablets or leaves were included between the ornamented covers, they were still called diptychs. The tablets were made of ivory, wood, or metal, and sometimes of slate or papyrus, or of gold and silver. The external faces were more or less ornamented; the interiors were smooth, so as to receive a coating of wax, or to admit leaves of parchment or papyrus. They were carried suspended to the belt or wrist; served for epistolary correspondence (in which case they were sealed by the writer before being sent to their destination); were presented as gifts by consuls and other high dignitaries to the emperors and senators, and to their friends and relatives; and were even distributed by them among the people on the occasion of the public games, &c. The oldest consular diptychs known bear the date of A. D. 405, and are attributed to Stilicho.—In liturgical usage the diptychs were public lists or tables, which in the early church were read by the deacon from the ambon during the celebration of the liturgy. They contained, in so many separate columns or leaves, the names of the persons who made "the offering" that day; those of the chief personages, lay and ecclesiastical, in communion with that particular church; the names of the saints, martyrs, and confessors of the faith; and those of the faithful who had departed this life in the orthodox communion. Hence, to have the name of any person, living or dead, erased from the diptychs, was equivalent to an act of excommunication.—In art the name diptych is given to two panels united by a hinge, whose interior surface is painted. It is common to meet with such diptychs containing on one side the angel Gabriel, and on the other the Virgin Mary receiving his salutation. When there is a large central compartment, with two side panels folding over it, it is called a triptych. Such is the celebrated *Dombild* or altarpiece



of the cathedral of Cologne, having in the centre the adoration of the Magi, and on the sides the legend of St. Ursula and her companions.

**DIRCE**, in Greek mythology, daughter of Helios and wife of Lycus, king of Thebes, who had repudiated Antiope, his first wife. Dirce, jealous of the latter, had her put in chains, but Zeus aided her to escape to Mount Cithæron, where she gave birth to two sons by him, Amphion and Zethus. To revenge the injury to their mother, these two went to Thebes, slew Lycus, and tied Dirce to the horns of a bull, by which she was dragged about until dead. The punishment of Dirce is the subject of the celebrated marble group known as the Farnese bull, in the national museum at Naples. According to Pliny, it was the joint work of the Rhodian sculptors Apollonius and Tauriscus, who cut it from a single block of marble, and was sent from Rhodes to Rome. It was discovered in 1546 in the baths of Caracalla, much injured, and was restored by Bianchi under the superintendence of Michel Angelo. It was at first placed in the Farnese palace in Rome, but in 1786 was removed to Naples. It represents Amphion and Zethus restraining the struggling bull, and preparing to bind Dirce to his horns, with Antiope standing near. Several animals are represented about the base.

**DIRECTORY, Executive** (Fr. *directoire exécutif*), the name given to the executive government of the first French republic, established by the constitution of Fructidor, year III. (August, 1795). This constitution was framed by the moderate republican party, whose influence prevailed after the fall of Robespierre. The legislative power was vested by it in two assemblies, the council of 500 and the council of the ancients, the former having the exclusive right of proposing laws for the consideration of the latter. The judicial authority was committed to elective judges. The executive directory consisted of five members, and was chosen one each year by the council of the ancients from a list of candidates presented by that of 500. The directory promulgated the laws, appointed the ministers, and had the management of military and naval affairs, and the right of repelling hostilities, though not of declaring war. The directors decided questions by a majority vote, and presided by turns three months each, the presiding member having the signature and the seal. During their term of office none of them could have a personal command, or absent himself for more than five days from the place where the councils held their sessions, without their permission; and after they had left office they could hold no command for two years, nor be re-elected for five. The balance of power established by this constitution excited antagonism between the different branches of the government. The convention decreed that in the first election two thirds of the members of the two councils should be chosen from its own body. This arbitrary act led to violent agita-

tions in Paris, and finally to an insurrection of the royalist sections on the 13th Vendémiaire (Oct. 5, 1795), which was suppressed by Barras and Bonaparte. The convention having held its closing session on Oct. 26, the two councils held their first on the 28th, and on Nov. 1 elected Barras and Laréveillière-Lépeaux, Rewbell, Letourneur, and Carnot as directors. Their first proclamation promised a firm rule and inspired confidence. Carnot organized the armies, and directed their movements; Moreau received the command of the army of the Rhine, Jourdan that of the Sambre and Meuse; Hoche suppressed the insurrection in the Vendée, and Bonaparte conquered Italy. But the elections of the year V. (May, 1797) gave the royalists a preponderance in the councils, which was supported by the minority of the directory, while Barras, Laréveillière, and Rewbell sided with the minority in the legislative bodies. The movements of the royalists became more and more threatening, when the majority of the directors agreed to save the republic by an act of violence. This was executed by the aid of the army on the 18th Fructidor (Sept. 4, 1797). More than 50 members of the two councils, with Carnot, Barthélemy, who had replaced Letourneur, and a number of other influential persons, were condemned to transportation, and a persecution of both royalists and anarchists was commenced. Merlin of Douai and François of Neufchâteau were substituted for the two proscribed directors, of whom Carnot escaped to Germany. Saved by the army of the interior, the republican rule was maintained by the victories and extortions of the armies abroad. The treaty of Campo Formio was concluded; Switzerland and the Papal States were overrun and revolutionized; and Bonaparte was sent to Egypt to attack England indirectly. But the extreme revolutionary party carried the elections for the year VI. (May, 1798), a part of which were annulled by another violation of the constitution. A new coalition against France was formed. Switzerland and Italy were lost as rapidly as won. The republicans became impatient of the rule of the directory, in which Treillard had replaced François, and Sieyès was elected instead of Rewbell. Finally the councils compelled Treillard, Merlin, and Laréveillière to resign on the 30th Prairial (June 18, 1799). Barras saved his office by the desertion of his associates, and maintained himself with Sieyès and the three new directors, Gohier, Moulins, and Roger Ducos, till the 18th Brumaire (Nov. 9, 1799), when Bonaparte overthrew the directory and the constitution, and became master of France under the title of consul. The directory ruled France four years and a few days, and had altogether 13 members, of whom only Barras officiated during the whole period.

**DIRSCHAU**, a town of Prussia, in the province of West Prussia, situated on the Vistula, 19 m. S. S. E. of Dantzic, on the railway from Berlin

to Dantzie; pop. in 1871, 7,761. The Vistula is crossed here by a magnificent railway bridge about 2,700 ft. long. The town is walled, and contains a Catholic and a Protestant church. The manufactures are principally of leather. Five annual fairs are held here.

**DISCIPLES, Church of the,** a religious body, designated as "Disciples of Christ," "Christians," the "Church of Christ," &c., resulting from an effort to effect union among the Protestant denominations in western Pennsylvania. In the beginning of the present century several independent religious movements for this purpose occurred in different parts of the United States. The one which gave immediate origin and distinctive character to the body now known as "Disciples" was initiated in 1809 by Thomas Campbell, aided by his son Alexander, to whose ability and energy its successful progress is mainly attributed, and by whom it was chiefly directed. The original purpose was to heal the divisions of religious society, and to establish a common basis of Christian union. It was thought that these objects could be attained by taking the Bible alone as a guide, and its express teachings as the only authoritative standard of faith and practice, allowing meanwhile entire liberty of opinion in relation to all matters not fully revealed. Upon these principles a considerable society was formed, consisting chiefly of members from Presbyterian churches. After some time the questions of infant baptism and the use of sprinkling as baptism became matters of investigation, and it was finally decided by a large majority that there was no Scripture warrant for either practice. Becoming then a society of immersed believers, they were soon after united with the Redstone Baptist association, stipulating, however, in writing, that "no standard of doctrine or bond of church union, other than the Holy Scriptures, should be required." By means of this union with the Baptists, the principles and views of the Disciples, developed and defended by Alexander Campbell in his writings and public discussions, were widely disseminated. Meanwhile the study of the Scriptures led by degrees to the discovery and introduction of several characteristics of primitive Christianity which, as the Disciples held, had been long overlooked and neglected. Among these, a prominent one was "baptism for the remission of sins." As the apostle Peter, in reply to believing penitents who asked what they should do, said, "Repent and be baptized every one of you, in the name of Jesus Christ, for the remission of sins, and ye shall receive the gift of the Holy Spirit," it was believed that the same answer should still be given to such inquirers, and that it was the divine plan thus to impart through the institution of baptism an assurance of pardon. This became therefore a distinguishing feature of the reformation urged by the Disciples. Another characteristic was the practice of weekly communion, after the example of the primitive

church. In pressing these matters upon the acceptance of the Baptists, a spirit of opposition was at length aroused in various quarters, especially in Virginia and Kentucky, and a separation to some extent ensued, many of the Baptists remaining connected with the Disciples. At the close of 1831 their numbers were still further augmented by a union between them and a numerous body which had originated in Kentucky and some other western states, under the labors of B. W. Stone and others, who, some years prior to the movement led by Thomas and Alexander Campbell, had separated from the Presbyterian communion, and in like manner attempted to effect a union of Christians upon the Bible alone. These persons, adopting baptism for remission of sins, and the ancient order of things as practised by the Disciples, became entirely assimilated with the latter.—Although the Disciples reject creeds as bonds of fellowship, and disapprove of the technical language of popular theology, they do not materially differ from the evangelical denominations in their views of the great matters of Christianity. The following synopsis by Alexander Campbell is a fair expression of their sentiments on the points involved: "1. I believe that all Scripture given by inspiration of God is profitable for teaching, for conviction, for correction, for instruction in righteousness, that the man of God may be perfect and thoroughly accomplished for every good work. 2. I believe in one God, as manifested in the person of the Father, of the Son, and of the Holy Spirit, who are, therefore, one in nature, power, and volition. 3. I believe that every human being participates in all the consequences of the fall of Adam, and is born into the world frail and depraved in all his moral powers and capacities, so that without faith in Christ it is impossible for him, while in that state, to please God. 4. I believe that the Word, which from the beginning was with God, and which was God, became flesh and dwelt among us as Immanuel or 'God manifest in the flesh,' and did make an expiation of sin, 'by the sacrifice of himself,' which no being could have done that was not possessed of a superhuman, superangelic, and divine nature. 5. I believe in the justification of a sinner by faith without the deeds of law, and of a Christian, not by faith alone, but by the obedience of faith. 6. I believe in the operation of the Holy Spirit through the word, but not without it, in the conversion and sanctification of the sinner. 7. I believe in the right and duty of exercising our own judgment in the interpretation of the Holy Scriptures. 8. I believe in the divine institution of the evangelical ministry; the authority and perpetuity of the institution of baptism and the Lord's supper." With the Disciples the Christian faith does not consist in the belief of these or any other tenets as intellectual conceptions of religious truth, but in a simple trust or personal reliance on Christ as the Son of God and the Saviour of sinners.

They hence require of candidates for baptism no other confession of faith than this. As to government, each church is independent, but the churches cooperate with each other in sustaining Bible societies and missionaries at home and abroad. Two classes of officers are recognized, elders or bishops and deacons, who are chosen by the members of each church, and to whom the interests of the congregation are confided.—According to a denominational almanac for the year 1867, the number of members in the United States was estimated at 424,500, chiefly in the southern and western states, the largest numbers being in Virginia (15,000), Missouri (22,200), Kentucky (75,000), Ohio (52,000), Indiana (70,000), Illinois, (33,000), and Iowa (15,500). In 1872 their number was estimated at 500,000. The denomination had in that year one university, the Kentucky university, at Lexington, Ky.; colleges at Bethany, West Va.; Indianapolis, Ind.; Eureka and Abingdon, Ill.; Oskaloosa, Iowa; Wilmington, Ohio; Franklin, Tenn.; Woodland, Cal.; and Jeffersonton and Eminence, Ky.; female colleges at Columbia, Mo.; Versailles and Harrodsburg, Ky.; and Bloomington, Ill.; and 12 academies and seminaries. The periodicals of the denomination were 6 weekly, 2 semi-monthly, 16 monthly, 1 quarterly, and 1 annual. The number of Sunday schools was 2,450 with 253,290 scholars. Churches have been established in Canada, the British islands, the West Indies, and Australia; and the establishment of a mission in Germany was resolved upon in 1871.

**DISCOPHORÆ.** See JELLY FISH.

**DISCOUNT,** a sum of money deducted from a debt due at some future period, in consideration of immediate payment. In commercial transactions it is customary, when a bill is to be discounted, to pay to the holder or presenter the amount minus the simple interest calculated for the time the bill has to run. Thus a person holding a bill for \$100 payable in one year at 7 per cent. would receive \$93, which would be considered its present value. The true discount, however, of any sum for any given time, is such a sum as will in that time amount to the interest of the sum to be discounted. Thus, in the above instance, the sum to be deducted from the bill would be, not \$7, but \$6 54 and a fraction, which would amount at the end of a year to \$7. The true rule for computing discount would therefore be: As the amount of \$100 for the given rate and time is to the given sum or debt, so is \$100 to the present worth; or, so is the interest of \$100 for the given time to the discount of the given sum. Elaborate tables have been calculated on this principle, but as abatement of the simple interest is generally resorted to, they are of little practical value.—Discount on merchandise, sometimes called rebate, is a deduction from the price of goods sold on credit, when the buyer finds means to make his payment before the stipulated time.

**DISINFECTANTS,** substances used to counteract or destroy noxious odors and exhalations, or whatever may produce infection. The term is also made to embrace substances used to prevent decay of organic bodies. (See ANTISEPTICS, and EMBALMING.) In the present article disinfectants will be considered as agents for deodorizing and fumigating. As the causes of infection exist in the atmosphere, and are spread over wide districts, disinfectants properly include whatever is used to purify the air, and the term may even be applied to the means employed to prevent the formation of noxious miasmata, as to a proper system of drainage, the destruction by fire of vegetable matter exposed to decay, the thorough ventilation of buildings, the provisions for abundant supplies of pure air and light, and the free use of clear water for washing away unclean matters. No more powerful disinfectant exists than the fresh wind, which stirs up the infectious vapors, dilutes them with pure air, and sweeps them away. Violent winds, as hurricanes, are observed to arrest the progress of disease; efficient ventilation has in many hospitals mitigated it to a wonderful extent. The light and warmth of the sun have also an extraordinary influence in promoting health and vigor, and destroying some of the causes of injurious exhalations. Other agents are abundantly provided by nature which man may employ to remove infectious matters. They may be swept away by running water, or their gaseous emanations be absorbed by the earth in which they are buried. Exposure to heat may change their properties, or cause their elements to enter into new and harmless combinations; or by a freezing temperature decomposition may be arrested, and the formation of noisome gases prevented. Peat bogs present their antiseptic qualities as means of accomplishing the same end, and the astringent extracts of the bark of trees, such as are employed in tanning, possess the qualities of disinfectants.—In the selection and preparation of these agents, none is found more efficient than that which imitates the great natural disinfectant, a strong current of heated air. The method of artificially applying it to the removal of noxious effluvia from clothes and articles of merchandise has been patented in Great Britain; the articles are exposed in large chambers to rapid currents of air, heated from 200° to 250° F., the infectious matters being decomposed by the heat, or swept off in the hot blasts. Earth and porous bodies generally are employed to absorb injurious vapors; none possess this property in so remarkable a degree as charcoal. De Saussure found that a single volume of this substance, prepared from boxwood, absorbed 90 volumes of ammonia; of sulphuretted hydrogen it took up 55 times its own bulk; of carbonic acid, 35 times; of carbonic oxide, 9.42; of oxygen, 9.25; of nitrogen, 7.50; and of hydrogen, 1.75. Bodies of animals have been buried in charcoal powder,

which, while it did not prevent decay, still arrested all escape of disagreeable odors. The gases it retained indicated that it exerts an influence in causing the decomposition of the exhalations, and the combination of their elements to form new compounds with the oxygen of the air. Chlorine, which has for many years been in use in hospitals and other places exposed to noxious exhalations, acts as a powerful disinfectant by producing a chemical change in the injurious compounds, and also by arresting decay. It is generated by the decomposition of hydrochloric acid, which is effected by adding to it some black oxide of manganese. The chloride of lime, as it is commonly known, is the usual medium for distributing it, the gas being freely evolved on the exposure of the salt to the air. It is set free by the presence of any acid fumes, and as carbonic acid is evolved in the decomposition of organic matters, the noxious effluvia themselves provide one of the agents for their own disinfection. Vinegar or dilute sulphuric acid, however, added to the chlorinated lime, causes a more rapid evolution of the disinfecting gas. In consequence of the acrid nature of the vapor, it should be used for fumigating rooms only when these are not occupied by invalids; and the same may be said of the disinfecting solutions, as the hypochlorite of soda, of which chlorine is the active agent. The more powerful fumes of nitrous acid, which possess the highest disinfectant qualities, are liable to the same objection; yet so important is their application regarded that Dr. Carmichael Smyth, who first proposed their use, received therefor from the British government the sum of £5,000. The unwholesome sulphuretted hydrogen is decomposed by these fumes, as it is by chlorine, the sulphur being set free and the hydrogen uniting with the disinfectants. In combination with some of the metals, chlorine has been much used as a disinfectant, especially with zinc, in the aqueous solution of the chloride of the metal, which is known as the disinfecting fluid of Sir William Burnett. Its use is somewhat objectionable, from its poisonous qualities. The same compound is advantageously applied to arresting dry rot in timber. Chloride of manganese is an efficient salt of similar properties, and, being the refuse of chloric manufacture, may be cheaply procured. Chloride of aluminum, under the popular name of chloralum, has recently come into use. The action of iodine is similar to that of chlorine, and more powerful. Its application is simple. The solid substance, exposed to the air in a plate, will disengage at ordinary temperatures sufficient vapor to exert a chemical action on deleterious organic compounds. Nitrate of lead has been recommended for its disinfectant properties, particularly in the solution known as Ledoyen's disinfecting fluid. It corrects the fetid odors of sulphuretted hydrogen and sulphuret of ammonium by decomposing those compounds, but it has no antiseptic prop-

erties, and is objectionable on account of its cost and poisonous nature. Sulphate of iron, which is used for the cleansing of sewers, drains, and soil pipes, depends for its efficacy upon a similar action, and upon its deoxidizing power. The permanganate of potassa is, under certain circumstances, an excellent disinfectant and deodorizer, readily parting with its abundant oxygen; but it is not volatile, and cannot be brought into efficient contact with large quantities of air, so that its action in purifying the atmosphere is insignificant. For washing dirty and decomposing surfaces, and for the disinfection of fluids, as bilge water, it has been found very effective. Sulphurous acid, including the sulphites and hyposulphites, which easily disengage it, is an exceedingly active substance in several ways; it is a deoxidizer, and has besides the power of destroying life in the lower organisms. Sulphurous acid may be generated by burning sulphur in the apartment to be disinfected, care being taken to remove anything which might be bleached by its action. It has been found, however, that although  $\frac{1}{4}$  of 1 per cent. of sulphurous acid in the atmosphere is sufficient to prevent the action of yeast as a ferment, yet  $\frac{1}{4}$  to  $\frac{1}{2}$  of 1 per cent. is not enough to destroy colors. It cannot be conveniently used in inhabited rooms, on account of its irritant properties; although some physicians who have used it consider that its power of producing bronchial irritation has been exaggerated, and that patients may become well accustomed to it. The sulphites and hyposulphites may be used for the deodorization of stables and manure heaps; for this purpose they have the advantage of adding to the fertilizing value of the substances acted upon, by retaining the phosphoric acid and ammonia. These salts have been used as medicines for the purpose of destroying a hypothetical ferment in the blood. Carbolic acid and creosote are disinfectants which have been much used of late. They prevent putrefaction by killing the microscopic organisms that accompany this process. They have, however, but little power in preventing the action of emulsine on amygdaline, or diastase on saliva or starch; from which it may be inferred that the estimate of their action upon other fermentations has been somewhat exaggerated. Carbolic acid may be employed by vaporizing it from a hot plate or brick, by scattering a spray of its solution through the air and upon the walls, by placing open dishes filled with the acid or with carbolate of lime in localities to be disinfected, or by using dilute solutions to wash floors, &c. Its use in the surgical wards of hospitals has been said to diminish the mortality from infectious diseases, such as erysipelas and pyemia. Dr. Sanson has shown that in order to purify the atmosphere properly, and prevent the development of fungi, bacteria, and vibriones, and hypothetically of disease germs, it is necessary that the disinfectants should be volatile, as in the case of iodine and

sulphurous and carbolic acids. The others, however, may be used to prevent or arrest the development of injurious gases from decomposing solids and fluids, or to neutralize them when formed.

**DISLOCATION** (Lat. *dis*, apart, and *locus*, place), in surgery, that displacement in the osseous system which results from the direct application of force or other long continued cause. All the joints are liable to dislocation, but it most commonly occurs to those which possess the greatest mobility; hence the shoulder joint is the most frequent seat of this accident. The head of the humerus or bone of the upper arm, forming a ball-and-socket joint in connection with the scapula or shoulder blade, is regulated in its motions by very strong muscles, and is but slightly impeded in its free motions by the very shallow socket in which it rests. While this arrangement bestows great freedom of action upon this joint, it renders it liable to dislocation in almost every direction. The most common is that which occurs when the arm is elevated above the head, by means of which the head of the humerus is thrown into the armpit. Next in frequency is the dislocation of the hip joint, which is generally produced by a sudden blow upon the knee when the thigh is flexed toward the abdomen, whereby the head of the thigh bone is drawn backward by the action of the gluteal muscles upon the dorsum of the ileum or pelvis. The jaw bone is often thrown out of place in laughing, and much more frequently in yawning. This accident sometimes occurs while speaking under undue excitement. It may be easily remedied by placing the thumbs on the back teeth so as to press them downward while the chin is raised by the fingers slowly upward. Care should be taken, however, to remove the thumbs quickly on the restoration of the joint, or they may be painfully compressed between the teeth.—The chief difficulty in restoring a dislocation consists in the opposition offered by the muscles, rendered acutely irritable by the unnatural position of the head of the luxated bone. In some instances this is overcome by reducing the heart's action by general bleeding. The warm bath and emetics are likewise used to relax the muscles, and with the same view tobacco moistened with water is sometimes laid upon the abdomen until it induces sickness and a disposition to syncope. But the safest and most efficient means of securing complete relaxation of the muscles is probably the etherization of the patient; and in this way a dislocation may sometimes be reduced with the exertion of a comparatively slight degree of force. The surgeon in reducing a luxated joint endeavors, by a steady application of force exerted in the direction of the joint, either to fatigue the muscles, or seize some moment when they are relaxed to slip the bone into its socket. Various degrees of force and different appliances are used to effect this object. In the case of the shoulder joint

the surgeon frequently forms a lever of the arm, with the heel of his boot placed in the armpit for a fulcrum, and by pressing the arm inward over this toward the body, overcomes the resistance of the muscles, and restores the joint. In the case of the hip joint, the force required is necessarily more considerable, and pulleys are often resorted to, by which means not only a greater but a steadier traction is exerted. A recent dislocation is much more easily reduced than one of long standing; indeed, no time should be permitted to elapse between the accident and an attempt at its reduction, for every hour adds to the uncertainty of success.—In geology, the term dislocation is applied to the change in the position of rocks caused by their being torn from their original place, either by upheaval or subsidence.

**DISMAL SWAMP, Great**, a large morass in Virginia and North Carolina, extending 40 m. S. from near Norfolk in the former state, and 25 m. E. and W. The soil consists of black vegetable matter to the depth of 15 ft., saturated with water, yielding to the tread of man, and during a large part of the year covered in many places with stagnant pools. Several small streams flow through it, and in the centre is Lake Drummond, 6 m. long and 3 m. wide, the surface of which is 21 ft. above tide water. The swamp is for the most part covered with a dense growth of cypress, juniper, gum, and cedar, and upon the drier ridges that intersect it are found the beech and oak. Much of the most valuable timber, however, has been cut down, and large quantities have been obtained from beneath the surface, where the fallen trunks have been preserved by the wetness of the soil. The Seaboard and Roanoke and the Norfolk and Petersburg railroads pass through the N. border. The great channel of transportation is the Dismal Swamp canal, made by the assistance of the national government and the state of Virginia, which connects the W. branch of Elizabeth river with the Pasquotank. It is 6 ft. deep, supplied chiefly by Lake Drummond, with which it is connected by a feeder, and passes for 20 m. through the swamp, affording an outlet not only for timber but for much of the agricultural produce of the E. part of North Carolina. Steam power is used upon it, and the tolls amount to about \$20,000 a year. The Chesapeake and Albemarle canal also passes through the swamp, connecting the E. branch of Elizabeth river with Currituck sound, and admits vessels of considerable size. In 1870, 4,382 vessels of all classes passed through it, and the revenue from tolls and towage was \$58,734. This canal contains a single lock, 40 by 220 ft., and is fed by tidal action. Several minor canals connect the mainland with Lake Drummond. A stage road runs parallel to the Dismal Swamp canal from the N. border to Elizabeth City, N. C. Roads are made in the swamp by laying logs 8 or 10 ft. long side by side on the surface of the soil or "sponge." They are passable by mules and

oxen, but carrying is done mostly by hand to the creeks and ditches communicating with the canals.—The productions of the Dismal Swamp consist chiefly of ship timber, boards, shingles, staves, railroad ties, and fire wood. It is especially noted for its shingles. A large force of colored men is employed during the drier months of the year in preparing the lumber for market. Its dimensions were first accurately estimated by Col. William Byrd in 1728, while engaged in surveying the boundary of Virginia and North Carolina. An account of his passage through the swamp has been preserved in the Westover MSS.—Along the coast of North Carolina are the Little Dismal and several smaller swamps, covering in the aggregate about 2,000,000 acres. They were once noted retreats of runaway slaves. (See BOG.)

**DISPENSATION**, the act by which an exception is made to the rigor of the law in favor of some person. To make a dispensation is an attribute of sovereign power. In the United States no power exists, except in the legislature, to dispense with law, and then it is rather a change of the law than a dispensation.—In the Roman Catholic church a dispensation is an exemption from ecclesiastical law, granted by the proper authority for "just and reasonable causes." The pope alone, and the persons by him empowered, can dispense with the laws which bind the universal church. In local laws, whether national, provincial, or diocesan, the dispensing power resides in the bishops and in those deputed by them. The divine law and the law of nature, according to the church, cannot be dispensed with.

**DISRAELI, Benjamin**, an English author and statesman, eldest son of Isaac Disraeli, born in London; Dec. 21, 1805. His mother's maiden name was Basevi. He received his education at home from his father and from private tutors. An intimate friend of his father, an eminent solicitor, who had a great practice and no son of his own, wished to make Benjamin the heir of his business, and took him into his office for a time. But the young Disraeli did not like the life of a lawyer, and was not ambitious of success in that direction. He therefore abandoned the solicitor's office, with its brilliant prospect of wealth and reputation, and devoted himself to literature. His personal beauty, refined manners, and remarkable powers of conversation soon made him a favorite in society. At the age of 19 he visited Germany, and on his return to England published in 1826-'7 his famous novel "Vivian Grey," the chief characters in which were faithful pictures of himself and of persons well known in English society. The originality, vivacity, and wit of this book gave it great celebrity, and it was translated into the principal languages of Europe. It is said by several of his biographers that at this period he was made editor of a daily paper, called "The Representative;" but this is not true. In 1828 he published in one volume "The Voy-

age of Captain Popenilla," a gay and good-humored but flimsy satire, which met with little success. The next year he commenced an extended tour in Italy, Greece, Albania, Syria, Egypt, and Nubia, and returned in 1831. Shortly afterward he published his second fashionable novel, "The Young Duke;" and in the following year another novel, "Con-tarini Fleming, a Psychological Autobiography," which Heinrich Heine pronounced to be "one of the most original works ever written," and which received high praise from Goethe and from Beckford, the author of "Vathek." Its subject is the development of the poetical nature, and it contains brilliant sketches of Italy, Spain, Greece, Asia Minor, Syria, and Egypt. The author himself has said of it recently, "It would have been better if a subject so essentially psychological had been treated at a more mature period of life." At this time Disraeli made his first attempt to enter parliament. He presented himself to the electors of High Wycombe, Buckinghamshire, near his father's residence, as a tory-radical, and was defeated by the whig candidate. In December, 1834, he was again defeated in Wycombe. He next appeared in May, 1835, at Taunton, as a thorough-going conservative. It was on this occasion that, when charged by somebody in the crowd with "O'Connellism," he called the great Irish agitator a "bloody traitor;" to which Mr. O'Connell made the retort, "For aught I know, the present Disraeli is the true heir at law of the impenitent thief who died on the cross." Disraeli challenged O'Connell's son, Morgan O'Connell, who had taken up his father's quarrel; but the challenge was not accepted. In the mean while Disraeli wrote and published several books. "The Wondrous Tale of Alroy," an oriental romance of extraordinary eloquence and power, depicting the adventures of a prince of the house of David, who in the 12th century proclaimed himself the Messiah, and called the Jews of Persia to arms, appeared in 1833, accompanied by "The Rise of Iskander," a tale founded on the revolt of the famous Scanderberg against the Turks in the 15th century; a political pamphlet entitled "What is He?" in 1834, in which he tried to explain his political views; "The Revolutionary Epic" and "The Crisis Examined" in the same year, and "A Vindication of the English Constitution" in 1835. In 1836 he published a series of letters in the London "Times" under the signature of "Runnymede," which were read with great interest on account of their remarkable wit and sarcasm. Toward the close of the same year he published a love story, "Henrietta Temple;" and in the spring of 1837 appeared "Venetia," a novel, in which he portrayed the characters and appearance of Lord Byron and Percy Bysshe Shelley. At last he achieved the great object of his ambition. In the first parliament of the reign of Victoria, being then 32 years of age, he

obtained a seat as representative of the conservative borough of Maidstone. His maiden speech was a failure. The house refused to listen, and clamored him down in the rude English fashion. He closed in the following words: "I am not surprised at the reception I have experienced. I have begun several times many things, and I have often succeeded at last. I shall sit down now; but the time will come when you will hear me." In July, 1839, this prediction began to be fulfilled; he made a speech which was listened to with attention, and praised for its ability. In that year he published his five-act tragedy, "Count Alarcos," founded on an old Spanish ballad, and in the same year contracted a most fortunate marriage with the wealthy widow of Wyndham Lewis, his friend and colleague in the representation of Maidstone. The happy influence of this union upon his career he has himself acknowledged in the graceful dedication of one of his novels to a "perfect wife." In 1841 he was elected from the borough of Shrewsbury, and in 1844 published "Coningsby, or the New Generation," which achieved great success and had a wide circulation. The cause of its extraordinary popularity, apart from its great literary merit, was the fact of its principal characters being drawn from well known persons then living. It was regarded also as an exposition of the views and designs of the famous half literary, half political party then attracting public attention under the name of "Young England," of which Disraeli was one of the most conspicuous leaders. In 1845 he published "Sibyl, or the Two Nations," which depicts with much care the condition of the English people at that period, and especially the Chartist agitation. In 1847 he was returned as one of the members for Buckinghamshire, and in the same year he published "Ixion in Heaven," with other tales, and also "Tancred, or the New Crusade," in some respects the best of his novels. He himself says in the preface to his collected works (1870), that "Coningsby," "Sibyl," and "Tancred" form a trilogy, the object of which was to delineate the origin and character of English political parties. He now began to take a leading part in the house of commons. His severe attacks on Sir Robert Peel, for alleged treachery to his party in the adoption of his free-trade policy, are among the most remarkable speeches in the annals of the British legislature. They established Disraeli's reputation as one of the most powerful debaters and keen and polished satirists in that body. In 1849 he became the recognized leader of the conservative party in parliament. A biography of his father, Isaac Disraeli (1849), and a memoir of his personal and political friend Lord George Bentinck (1852), were his next literary productions. In March, 1852, in the first Derby administration, he received the appointment of chancellor of the exchequer, was made a member of the privy council, and became

leader of the ministerial party in the house of commons. He went out of office with the rest of the Derby ministry in December of the same year. In February, 1858, when Lord Derby again accepted the task of forming a new cabinet after the downfall of Lord Palmerston, Disraeli again became chancellor of the exchequer. In February, 1859, he brought forward an elaborate plan of electoral reform, a principal feature of which was the extension of the suffrage to the whole body of the educated class without regard to property. The bill was defeated in the house of commons, March 31, and parliament was dissolved April 23. The Derby administration retained its place till June 11, when the new parliament passed a vote of want of confidence, and the ministry resigned. It was succeeded by the Palmerston-Russell cabinet, and on the death of Lord Palmerston, Oct. 18, 1865, by the Russell-Gladstone ministry, which remained in power till June, 1866, when, owing to the unsatisfactory nature of the reform bill proposed by them, a vote of want of confidence was passed, and they resigned. Disraeli during this period was the leader of the opposition in the house of commons. A new ministry was formed, July 6, the earl of Derby being prime minister and Disraeli chancellor of the exchequer. He was the chief supporter of the reform bill, signed by the queen Aug. 15, 1867, which extended the right of suffrage to all householders in a borough, and to every person in a county who had a freehold of 40 shillings. The earl of Derby resigning in February, 1868, Disraeli became prime minister; but a majority in parliament was opposed to the position which the ministry took on the question of disestablishing the church of Ireland. Parliament was dissolved, but the new elections showed a strong majority for the opposition, and without waiting for its meeting Disraeli with his colleagues resigned, Dec. 2, 1868, and was succeeded as prime minister by Mr. Gladstone. In 1870 Disraeli published "Lothair," a politico-religious novel, aimed at the Fenians, the Communists, and the Jesuits. It had a great success, its circulation in the United States alone exceeding 80,000 copies. In 1868 he was offered a peerage by the queen, which he declined for himself, but accepted for his wife, who was made Viscountess Beaconsfield on Nov. 28 of that year. She died Dec. 23, 1872. In February, 1874, the parliamentary elections having resulted in a conservative majority, Mr. Gladstone resigned, and Mr. Disraeli again became prime minister.—The career of Mr. Disraeli is one of the most extraordinary in English history. By genius and energy unaided by wealth or family connections, he has made himself leader of the house of commons, minister of finance in the most commercial of countries, and twice prime minister of one of the mightiest of modern empires.

**DISRAELI, Isaac**, an English author, born near Enfield in May, 1766, died Jan. 19, 1848,

His father removed to England in 1748 from Venice, whither his Hebrew ancestors had fled in the 15th century from the inquisition in Spain. In Venice they assumed the name of Disraeli (originally written D'Israeli), "a name never borne before or since by any other family, that their race might be for ever recognized." Isaac was an only son, and was intended for the pursuits of commerce, by which his father had attained to fortune. The latter was seriously alarmed when his son during his school days produced a poem; "the loss of one of his argosies uninsured could not have filled him with more blank dismay." He was sent to a college at Amsterdam, where he studied the philosophical works in fashion at the time, and when 18 years of age returned to England a disciple of Rousseau. When informed that a place in the establishment of a great merchant was prepared for him, he replied that he had written and intended to publish a poem of considerable length against commerce, which was the corrupter of man. Pensive and sensitive, fond of solitude and the society of books, he found no literary friend and counsellor, and was sent by his parents to travel in France, with the hope that adventures and change of scene might divert him from the eccentricity of his course. He lived in Paris, associating with learned men and frequenting libraries, till 1788. On his return he published anonymously in 1789 a satire "On the Abuse of Satire," in polished verses, which was directed against Peter Pindar, then in the height of his popularity. This venture obtained for him the friendship of Mr. Pye, afterward poet laureate, through whose influence the elder Disraeli was persuaded to renounce the effort to convert a poet into a merchant, and was finally induced to furnish means sufficient to enable his son to gratify his passion for book-collecting and for tranquil study. The son now wrote some metrical pieces for the magazines, and in 1790 "A Defence of Poetry," of which he afterward burned all the copies he could obtain. In 1791 he published the first, and in 1793 the second volume of his "Curiosities of Literature," a product of curious erudition, abounding in discursive and anecdotal criticisms. A new edition of both volumes appeared in 1794. This was followed by "Miscellanies, or Literary Recreations" (1796); "Vaurien, or Sketches of the Times, a Philosophical Novel" (2 vols., 1797); "Romances," a volume of prose tales (1799); "Narrative Poems" (1803); "Flim-Flams, or the Life and Errors of my Uncle, and the Amours of my Aunt" (3 vols., 1805); and "Despotism, or the Fall of the Jesuits," a novel (2 vols., 1811). In 1812 appeared his "Calamities of Authors, including some Inquiries respecting their Moral and Literary Character;" in 1814, "Quarrels of Authors, or some Memoirs for our Literary History, including Specimens of Controversy to the Reign of Elizabeth;" and in 1816, the most finished of his compositions,

"Illustrations of the Literary Character, or the History of Men of Genius, drawn from their own Feelings and Confessions." All of these works are amusing and anecdotal, and reveal the author not only as a literary antiquary, but as a man of humor, thoughtfulness, and elegant tastes. His "Curiosities of Literature" had reached the fifth edition, when in 1817 he added a new volume, containing more elaborate essays than the preceding; and the success of the publication was such that he rapidly produced three additional volumes. He was five years in the composition of his work on the "Life and Reign of Charles I.," which appeared in 1828-'31, and gained for him the degree of D. C. L. from Oxford. He had long meditated a history of English literature, for which all his previous writings had been preparatory; but in 1839 a paralysis of the optic nerve prevented him from pursuing his researches, and a selection from his numerous manuscripts was given to the public in 1841 under the title of "Amenities of Literature." During the latter part of his life he resided on his manor of Bradenham, Buckinghamshire. "He was," says his son, "a complete literary character, a man who really passed his life in his library. Even marriage produced no change in these habits; he rose to enter the chamber where he lived alone with his books, and at night his lamp was ever lit within the same walls. In London his only amusement was to ramble among booksellers; in the country he scarcely ever left his room but to saunter in abstraction upon a terrace, muse over a chapter, or coin a sentence." A new edition of his works, edited and annotated with a memoir by his son, Benjamin Disraeli, was published in London in 1850, and republished in New York in 9 vols.

**DISSEISIN**, a term used in the English law to express the turning a man out of possession of a freehold estate in lands, that is to say, an estate in fee or for life. It is not applied to dispossession of a term of years, nor is it strictly applicable to an incorporeal estate, inasmuch as that species of estate does not admit of actual possession in a literal sense; yet constructively there may be disseisin of incorporeal rights, as an office, rent, and the like. According to the old common law, disseisin always imported a wrongful putting of another out of possession. An entry by a stranger after the death of the owner of a freehold, and before the heir or devisee had taken possession, was called an abatement; an entry after the determination of a particular estate, before the person entitled to the reversion or remainder, was an intrusion; an alienation by a tenant for life for a longer term than he was entitled to convey was a discontinuance; and different remedies were necessary for the recovery of the possession while the old forms of real actions were in use. As disseisin commenced by a wrongful act of the disseisor, the person disseized could repossess himself by an entry



upon the lands; but if the disseizor died in possession, there could be no entry against his heir, but the rightful owner was then put to an action for the recovery of the possession. This rule, however, was subject to certain exceptions, as disability of the person entitled to make the entry; and finally by statute five years' possession by the disseizor before his death was necessary in order to take away the right of entry. It was required that the entry should be peaceable, for if force was used a summary process was given by statute to restore the possession to the person thus put out, although, as before supposed, his possession was wrongful, provided he or those from whom he claimed had held the premises three years. Possession, although not conclusive evidence of the right of property, was yet deemed of such importance that it could be the subject of an action without involving the question of the real ownership of the fee. The old forms of proceeding by writ of entry, assize of novel disseisin, and the like, were possessory actions. The title to the fee could be determined only by a writ of right or other analogous proceeding. A limitation of time was prescribed for the bringing of possessory actions, which has varied at different periods; but now, by statutes 3 and 4 William IV., c. 27 (1833), no entry can be made nor action brought but within 20 years after the right of entry or action accrued; descent cast (as it was called when the disseizor died in possession) is not allowed to defeat such entry or action, and all the real actions formerly used are abolished, except actions for dower, *quare impedit* (which relates to certain incorporeal rights), and ejectment, which last is the mode by which all titles to corporeal estates are now tried. In this country, these provisions have been long since generally adopted, and even greater changes made; and the term disseisin has been little used in American law, and merely as synonymous with dispossession.

**DISSENTERS**, the general name in England for those Protestants who differ from the established church in doctrine or ceremonies. The origin of dissent was in the reign of Edward VI. John Hooper was appointed bishop of Gloucester, but refused to swear obedience to the metropolitan or wear the episcopal robes. His views were opposed by Cranmer and Ridley, and he was imprisoned for preaching them, but had many followers, who were called nonconformists. During the reign of Elizabeth several acts were passed against dissent, especially the "Act of Uniformity" (1558), which enforced severe penalties against any one conducting public service in any other manner than that prescribed by the "Book of Common Prayer." These acts were not altered under James I., and under Charles I. dissent was punished with increased severity. Upon the fall of the latter episcopacy was proscribed, and at first the Presbyterians, and afterward the Independents, had the ascendancy. Episcopacy was restored with Charles II., and a new

act of uniformity was passed in 1662. The "declarations of indulgence" of Charles II. and James II. gave temporary relief, but it was not until the revolution of 1688 that dissenters enjoyed any real toleration. After this the penal laws were gradually ameliorated. The test and corporation acts were repealed in 1828, admitting them to active citizenship; in 1836 the marriage law was modified so as to allow marriages to be solemnized in the presence of the district registrar; in 1860 an act was passed for the admission of children of parents not connected with the church of England to the endowed schools, where such connection is not expressly required by the endowment; in 1867 the former religious restrictions as to the lord chancellor of Ireland were removed, and it was made lawful for judicial or corporate officers to attend their places of worship in their official robes, and a new oath was provided in place of the former oaths of allegiance, supremacy, and abjuration; religious tests in the universities were abolished as to all lay students in 1871. The disabilities of dissenters at present are little more than such as are necessarily involved in the existence of the established church. In the 17th century the great classes of dissenters were the Presbyterians, Independents, Baptists, and Quakers. The most numerous now are the Methodists, who did not begin as avowed dissenters, and some of whom do not now avow dissent. There are several subdivisions of Methodists, and many minor bodies which may be considered as subdivisions of the leading denominations previously mentioned.—In Scotland the Presbyterian church is established by law, and before the separation of the Free church the largest class of dissenters was that generally called Seceders, originating in a separation from the established church in 1736. They were divided into Burghers, Anti-Burghers, Original Burghers, and Original Seceders. The most of the Burghers and Anti-Burghers united in 1820 under the name of the "United Associate Synod of the Secession Church;" and in 1847 this body united with the Relief church, which had seceded from the establishment in 1752, the aggregate body taking the name of the "United Presbyterian Church." In 1843 a very large secession, led by Dr. Chalmers, formed the Free church of Scotland, now much the largest body of dissenters there. These bodies differ from the church of Scotland only in regard to the relation of the church to the civil government. There are also many Congregationalists or Independents and Baptists in Scotland.—The disestablishment of the Episcopal church in Ireland in 1868 has made the term dissenters no longer applicable there.

**DISSOCIATION**, in chemistry, a term applied to the influence of heat and pressure on chemical action. The word was first employed by Henri Sainte-Claire Deville, who in November, 1837, read before the French academy of sciences a paper "On the Dissociation or Spon-

taneous Decomposition of Bodies under the Influence of Heat." He says: "By selecting a proper compound and heating it sufficiently, the distance between the molecules can be increased to such an extent that they will separate into their elementary condition. This is a spontaneous decomposition, not determined by any chemical action. I propose to call it the dissociation of compound bodies." In 1846 Grove showed that fused platinum could determine the decomposition of water into its elements. Deville repeated this experiment on a large scale by pouring fused platinum into water. He obtained an explosive mixture of hydrogen and oxygen, and believes that at the temperature of the fusion of platinum water is dissociated into its constituents. Analogous experiments can be performed on solids. Debray showed that when Iceland spar is heated in a tube from which the air has been exhausted, no decomposition takes place in mercury vapor at  $350^{\circ}\text{C}$ ., and a scarcely perceptible decomposition in sulphur vapor at  $440^{\circ}\text{C}$ .; but at  $860^{\circ}\text{C}$ . in vapor of cadmium it becomes very perceptible, and goes on till the tension of the liberated carbon dioxide becomes equivalent to 85 millimetres of mercury; on raising the temperature to  $1042^{\circ}\text{C}$ . in vapor of zinc, more carbon dioxide is evolved. If, on the other hand, the apparatus be allowed to cool, the carbon dioxide is gradually reabsorbed by the quicklime, and a vacuum is reestablished in the apparatus. Lamy has applied these results to the construction of a pyrometer for the measurement of high temperatures. The apparatus consists of a porcelain tube glazed on both sides, filled with pure carbonate of lime; one end of the tube is closed, the other connected with a manometer. By reading the volume of gas in the pressure gauge, and consulting the tables of tension, the temperature is determined. According to Deville, there is a tension of dissociation analogous to the tension of vapors, and the evaporation of a liquid or the decomposition of a carbonate is subject to the same laws. In Fownes's "Chemistry," the exceptions to the law of molecular vapor occupying twice the volume of hydrogen is explained on the principle of the dissociation of the vapors at the high temperature required for the determination of their vapor density. Several writers on geology, among them Fournet and T. Sterry Hunt, have had recourse to Deville's theory of dissociation to explain the origin of rocks and the action of forces in primeval chemistry. The force of chemical affinity appears to be suspended by great heat, so that at a high temperature, like that of the sun, we may imagine that chemical elements, such as oxygen, hydrogen, chlorine, and sodium, can exist in the gaseous state, intimately mixed, but chemically uncombined. Many of the phenomena attributed by Berzelius to catalytic action are now explained on the principle of dissociation. Since attention was called to the subject by

Deville, a large number of bodies have been investigated with reference to the tension of dissociation, and the doctrine has been pushed to the determination of the temperature of combustion, also to the better understanding of efflorescence and the phenomena of vaporization. The dissociation of carbonic acid was accomplished by Deville by heat; it has since been performed by Thénard by the electric current. Carbonic oxide, sulphurous acid, hydrochloric acid, ammonia, and hydriodic acid have been dissociated by various chemists. It is the opinion of Dumas that Deville's theory of the tension of dissociation is as important to chemistry as Dalton's law of the tension of vapors was to physics.

**DISTILLATION** (Lat. *destillare*, to drop), the conversion of a liquid or a solid into a vapor and condensing it; usually applied to liquids. If sea water is boiled, the vapor which passes off leaves behind the salts and other substances held in solution, and by condensation in the atmosphere, or against cool surfaces, is converted into drops of pure distilled water. By artificial processes of a similar nature a volatile liquid may be separated from one less so, as alcohol, acetic acid, or ether from water with which they may be mingled. The volatile principles of plants may be extracted by water or other liquids, and by distillation separated in a pure state, or dissolved in the liquid used for extraction. Solid vegetable and animal substances, by exposure to heat in vessels more or less closed, undergo a process in which the organic compounds are destroyed, and their constituents recombined, partly in the form of volatile products, which may be collected as distillates, and partly as non-volatile residuum. By subjecting wood to such a process, charcoal, tar, pyroligneous acid, and naphtha are produced; and by heating bituminous coal in close crucibles, illuminating gas, coke, coal, naphtha, and other products are separated. When solid substances, such as sulphur or camphor, are volatilized and condensed, the process, strictly speaking, is not distillation, because there is no collecting in drops; but it is called sublimation. In the chemical laboratory distillation is commonly conducted in glass retorts and receivers, the boiling taking place in the

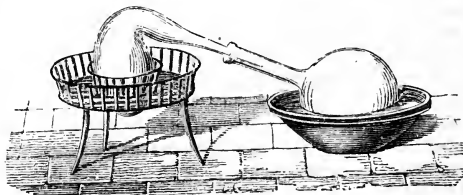

FIG. 1.—Simple Distilling Apparatus.

retort and the condensation in the receiver, which is usually cooled by the application of water or ice to the exterior. The simplest apparatus of this kind is shown in fig. 1.

When large products are required, more efficient forms of apparatus must be employed. Such are stills, in which the retort as well as the condensing portion is made of metal, generally copper or iron. Usually, instead of a receiver of the ordinary form, the neck of the retort, or a tube from the boiler, is converted into a long coil, called a worm, which, being immersed in a tub of water, causes condensation of the vapors within. A simple form of still, often used when considerable quantities of distilled water are required, and also for other pharmaceutical purposes, is represented in fig. 2. The retort is all that portion of the apparatus which sets in and upon the furnace, including the neck *e*, terminating at *d*, in the worm *d*, which passes through a cooler *e*, which is supplied with cold water by the funnel *h*, the water entering at the bottom and flowing out at the top. It will be seen that the form of this apparatus will prevent some of the less volatile portions of

ern nations in the writings of Arnoldus de Villa Nova, and his pupil, Raymond Lully of Majorea." But there are now few nations above the condition of savages who do not prepare some kind of alcoholic liquors by distillation. The fermented juices of the grape and other fruits, and the fermented infusion of grape sugar derived from malted liquors, contain the same intoxicating principle, alcohol, which it is the object of distillation to obtain in a more condensed form, and which when so obtained from liquids of different qualities retains the peculiar aroma and flavor of the plant, until by repeated distillations and rectifications the pure alcohol is at last obtained from peculiar volatile oils or flavors. All the juices of plants which can undergo vinous fermentation, and all vegetable matters which contain starch, may thus be made to produce alcoholic liquors. Some animal fluids also, which contain saccharine matters, as milk, may be made to furnish alcohol by fermentation and distillation. An intoxicating liquor from this source, called *kumiss*, is made in Tartary, both simply fermented and distilled. The fruits of each country furnish spirits of their peculiar flavors when these are obtained directly from the fermented juice; but if this is first allowed to crystallize, the sugar so obtained, on being redissolved and fermented, is found to have lost the aroma of the plant. Thus, the high flavor of the rum which is distilled from fermented fresh cane juice is not found in the distillate from fermented sugar and molasses. Sugar-growing countries produce rum, vine-growing countries brandy, and grain-growing countries whiskey and gin. The Chinese manufacture a distilled liquor from rice, and the inhabitants of Kamtchatka another from mushrooms. The processes of obtaining these liquors are essentially the same, except that the cereals require some preparatory operations before they are ready, like the saccharine juices, for fermentation, and these operations are almost identical with those employed in brewing ale; the only difference being that in preparing the wort which after fermentation is to be distilled, the action of the diastase in the malt is continued until the dextrine is transformed into grape sugar. The grain is subjected to the process of mashing, and the resulting wort to that of cooling and fermentation, after which follows the distillation.—A brief account of the manufacture of whiskey, as performed in the great distilleries of Scotland, will sufficiently explain the various operations. Barley is commonly used as the starchy material, and is more or less mixed with oats, rye, or other grains. It may be malted wholly or in part, or may be used with sugar. Barley malt is the best material, but the heavy duty imposed upon it restricts its use. According to Dr. Thomson, 40 bushels of ground barley are mixed with 20 bushels of bruised malt, in a mash tun of cast iron, together with about 750 gallons of water,

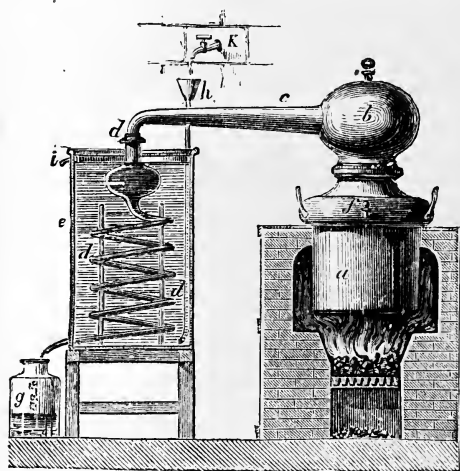

Fig. 2.—Still.

the liquid subjected to distillation from passing over, as they may with the application of much heat in the common retort in fig. 1, a considerable condensation taking place in the dome *b*. Liebig's laboratory distilling apparatus is constructed by passing the neck of a retort into a Liebig's condenser, which consists of a glass tube surrounded by a metallic one, of tin or copper, in the lower part of which water enters, flowing out at the top. The arrangement is on the same plan as the still in fig. 2, only instead of a worm there is a straight tube.—The preparation of an alcoholic liquor by separating the more volatile portions of the fermented juices of fruits and infusions of grains does not appear to have been understood by the ancients. Ure says: "It seems to have been invented by the barbarians of the north of Europe as a solace to their cold and humid climate, and was first made known to the south-

at a temperature of about 150° F. The mashing is continued one hour and a half, during which time 500 gallons more of water at 190° to 205° are introduced at intervals, to keep up the heat. The whole is then allowed to infuse two hours, during which time the grain subsides, and the liquid above it is a saccharine turbid fluid, called wort, which also still contains some starch and dextrine; but these by the action of the diastase are gradually converted into grape sugar. At the end of the two hours' infusion the greater part (usually about two thirds) of the wort is drawn off, and 500 gallons of water at 190° is added, and the infusion is renewed and continued another hour and a half. After the wort is again drawn off, a third infusion succeeds, with 800 gallons of boiling water. This being well stirred for 20 minutes, and then left about half an hour, the saccharine matters are found to be extracted. The weak wort is then drawn off and boiled down to the required strength, or it is added to the first and second worts, or is kept to be used instead of pure water for the first infusion of the next mashing. Strong worts are not desirable, the fermentation being more complete and the yield of spirits greater when they are of moderate specific gravity. By the old excise laws of Great Britain they were required to be of a certain high degree of strength, but in Scotland and Ireland they are now allowed to range from 1030 to 1080 sp. gr., water being 1000. The next process is that of cooling the worts, and in consequence of the tendency of those produced from raw grain to become acid, this must be rapidly accomplished. In some distilleries the wort is run into large shallow coolers in airy situations in the upper part of the building. In others the cooling is done by a more compact form of refrigerator, a description of which is given in the article BREWING. The temperature is usually reduced to between 70° and 75°, when the worts are transferred to the fermenting tuns, and yeast is added in the proportion of about one gallon to 100 gallons of wort. The object of fermentation is to convert all the saccharine matter, if possible, into alcohol and carbonic acid; but the presence of the alcohol as it is formed impedes the progress of this change, and a quantity often amounting to one fifth of the whole saccharine matter escapes decomposition. By the invention of Mr. Sheridan in fermenting the wash in close tuns, and causing the alcohol to evaporate by using a powerful air pump, the whole saccharine matter was converted into alcohol; but the excise restrictions prevented the adoption of the improvement. As the fermentation proceeds the liquor attains a less specific gravity, and when successfully conducted its density gets to be the same as that of water. If it is pushed too far, or goes on sluggishly or at too high a temperature, loss will result by a portion of the alcohol passing to acetic acid, the presence of which is indi-

cated by increased specific gravity, as well as by its peculiar odor and taste. The process of distillation, which, by distinguishing the preparation of ardent spirits from that of fermented liquors, gives its name to the whole operation, now succeeds the fermentation. It is conducted in stills of various sizes and forms, some of which have a capacity equal to distilling from 2,000 to 3,000 gallons of wash per hour. The origin of the first still which abolished to a great extent the use of the worm and substituted condensing vessels, which principle has been retained with modifications in nearly all subsequent inventions of the kind, is due to a Frenchman named Édouard Adam, who is said to have been a distiller, unacquainted with anything more than the routine of his trade. In 1801 he witnessed some experiments with a Woulfe apparatus at a chemical lecture in Montpellier, and was so impressed with its advantages that he soon after constructed a still upon the same prin-

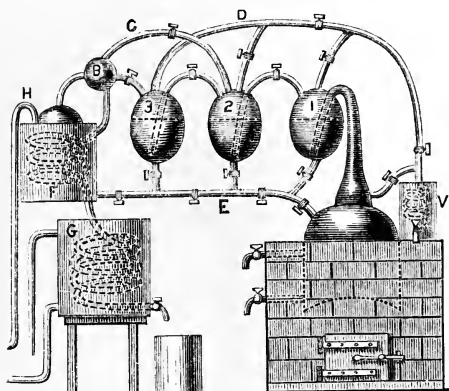

FIG. 3.—Édouard Adam's Still.

ciple. This succeeded so well that the whole process of distillation was soon completely changed. The uses of Woulfe's apparatus are described in the article on GAS, and by referring to that it will be seen that Adam's still was one of the happiest adaptations of a laboratory appliance to a manufacturing purpose. The modification of it as made by M. Adam is represented in fig. 3. A number of egg-shaped copper vessels, corresponding to the Woulfe bottles, are placed in convenient situations near each other, the terminal ones being connected on the one hand with the retort or boiler containing the fermented liquor or wine, and on the other with a worm which is immersed in a cooler. The neck of the retort passes into the first egg-shaped vessel, dipping below the surface of the liquor. It is perforated at its termination with minute holes through which vapor passes. A pipe from the first egg leads to the second, also dipping beneath the surface of the liquor, and so on, from one to the next, whatever the number may be. From the last egg a tube enters the globe B before

passing into the worm, whose use will presently be explained. From next to the last egg, or from any one of the series, an extra tube, C, also passes into the globe B, by which arrangement one or more of the eggs may be dispensed with when the distillation does not need to be carried very high. Another pipe, D, connects each egg and also the boiler with a small worm, V, which is used for testing the strength of the distillate in any one of the eggs, or from the boiler. Another pipe, E, leads from the cooler F into the boiler, and another, H, into the cooler from the storehouse where the wines are kept. The worm in the cooler F, moreover, leads into another worm in the cooler G. This still is worked in the following manner: The cocks connecting the upper tubes are closed, and those in the lower pipe, E, are opened. The wine is pumped from the storehouse through the tube H into the cooler F, whence it flows into the boiler. When this is about two thirds full the cock next it is closed, and the wine is forced up into the first egg; when this is about half filled the cock next it is closed, when the second egg is treated in the same manner; and so on through the series, except the last one, which serves as a condenser and is surrounded with cold water. The lower cocks are now closed, and the upper ones communicating between the eggs, and with the worm, are opened. Heat is applied to the boiler, and the mixture of alcoholic and watery vapor is carried into the first egg, and there condensed by the wine, quite rapidly in the beginning of the process, so that for a time no vapor passes over into the second egg. The wine in the first egg, however, gradually comes to its boiling point, which, by reason of its containing more alcohol than that in the boiler, is at a lower temperature. In consequence, the vapor which passes into the second egg has a greater percentage of alcohol than that which it received. This vapor, being condensed, will cause the liquor in the second egg to be stronger than in the first, and therefore to boil at a still lower temperature. The successive eggs, as they recede from the boiler, will thus contain stronger and stronger spirits, so that the last one may be made to receive alcoholic vapor of any desired strength. This is passed into the worm in F and condensed either in that or in the succeeding worm in the tub below, which is filled with water, kept cool by a constant flow. The upper cooler, containing the wine, is kept closed, except that a pipe leads into the globe B. This arrangement is for the purpose of preventing loss of spirit by evaporation, which would be considerable at the temperature it attains by contact with the worm. The excise laws of Great Britain prevented the introduction of this still into that country until after their modification in 1815. Adam's apparatus was in the mean time much improved in France by Isaac Bérard, Cellier-Blumenthal, and Derosne. The modification of Cellier-Blumenthal, im-

proved by Derosne, and now called Derosne's still, is represented in fig. 4. It consists of two boilers, A, A'; a first rectifier, B; a second rectifier, C; a wine heater, D, containing a dephlegmator; a condenser, F; a supply regulator, E, for controlling the flow of wine from the reservoir G, which is accomplished by means of a floating ball. The still is worked in the following manner: The boilers are about two thirds filled with wine, or the liquor to be subjected to distillation,

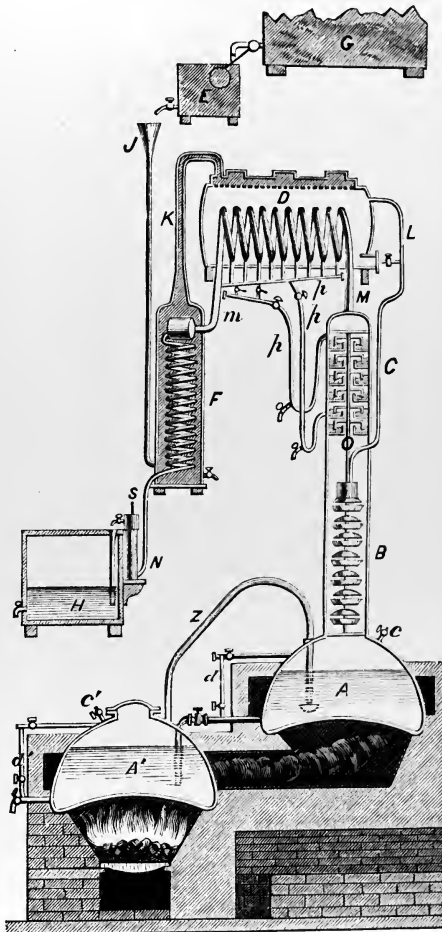

FIG. 4.—Derosne's Still.

through the cocks *c, c'*. The proper quantity is indicated by the glass gauges *d, d'*. Wine from the reservoir G is then let into the funnel J, by which the condenser F and the wine heater D are filled. On the application of heat the low-wine vapors pass from the lower into the upper boiler through the pipe Z, the extremity of which is enlarged and perforated with small holes. Here the vapors are condensed, increasing the strength of the wine in

the upper boiler, and consequently lowering its boiling point. The vapors ascend into the rectifiers B and C. The lower rectifier, B, contains a number of shallow pans perforated with holes, and a number of spherical disks, also perforated with holes, placed above them, in pairs, the convexity of each disk being upward, and receiving the drip of the shallow pan next above it. This drip is produced by warmed wine which flows from the wine heater through the pipe L. By these means the vapors ascending from the upper boiler have their more watery portions condensed, while the alcoholic vapor continues to ascend. The dripping wine also has a portion of its alcohol expelled in the form of vapor, which ascends with the vapor coming from below into the upper rectifier through the orifice O in its bottom. This upper rectifier communicates through the tube M with a worm (which is the dephlegmator) in the wine warmer D, the worm ending in the tube *m*, which again terminates in the worm contained in the condenser F through a cylindrical connection in its upper part. The worm in F terminates in a small vessel, N, which is furnished with an alcoholometer. The alcohol in N flows from its upper part into the cistern H. The upper rectifier C is divided into a number of compartments by as many horizontal partitions, each disk having an orifice in its centre, like the orifice at O. To each of these orifices on the upper side of the partition is adjusted a short open vertical tube. A short distance above each tube is placed an inverted pan, having its edges descending about three fourths of an inch below the level of the upper orifice of the tube. As the vapors ascend from the lower rectifier into the upper one, a portion of them condense and collect upon the bottom of the compartments until they rise slightly above the edges of the inverted pans and nearly to the upper orifices of the tubes. When this takes place the vapor can only pass upward by forcing its way under the edges of the pans, by which means the more watery portion is still further condensed, the more alcoholic vapor, having a higher tension, retaining its gaseous form, and passing on through the tube M into the dephlegmatory worm in the wine heater, there to be partially condensed; which process heats the wine surrounding the worm. A phlegma collects in the lower convolutions, which may be drawn off by means of the pipes *p, p, p*, and transferred at pleasure either into the tube *m* or into the upper rectifier. The purer alcoholic vapors which arise pass through the dephlegmator into the condensing worm in the condenser F, whence they flow in liquid form into the vessel N, and thence into the cistern H. The strength of the alcohol produced by this still depends upon the number of windings of the dephlegmator, and the number of partitions in the upper rectifier. Derosne's still requires but little fuel, distils rapidly, and yields a good spirit,

which may be varied in strength at pleasure; but it is rather complicated, and may with advantage, especially when spirits of only one strength are required, be replaced by a simplification of it, devised by Laugier.—The products of the distilleries of different localities are distinguished by peculiar flavors which give them a reputation; but they are not always, especially when the liquor is made from cereals, derived from the original qualities of the materials, but often from the fuel used in drying the malt. Much of the Scotch and Irish whiskey possesses the peculiar flavor of peat smoke. Brandies manufactured from wines are made to retain their peculiar flavors by conducting the distillation at a temperature sufficient to carry over the volatile oils and ethers, and also enough water to reduce the strength considerably below that of ardent spirits produced in Great Britain; but they may be given strength by the addition of pure spirit.—Common alcohol is the hydrated oxide of ethyle, or ethylic alcohol,  $C_2H_5O + H_2O = C_2H_6O$ . In the process of vinous fermentation there are formed, under conditions which are not yet clearly understood, other homologous alcohols, such as propylic, butylic, and amylic alcohols, in greater or lesser quantities. They have a higher boiling point than ethylic alcohol, and therefore do not usually appear in the first products of distillation; but in the latter stages of the operation, when the heat is raised, they pass over into the worms or condensers. These alcohols, mixed with some ethylic and small quantities of various ethers and volatile fatty acids, such as capric, caprylic, and formic, constitute an oily substance which passes under the general name of fusel oil. That of potato spirit consists almost wholly of amylic, combined with a small quantity of ethylic alcohol. This fusel oil imparts a very disagreeable taste to spirits, and to get rid of it is often a matter of importance. The process is called rectification, and may be conducted with or without redistillation. Its complete removal by distillation, even with the use of alkalis and other substances, is somewhat difficult and expensive, notwithstanding that the boiling point of absolute ethylic alcohol,  $173^\circ$ , is much lower than that of the others, amylic alcohol boiling at  $270^\circ$ . It is found, however, that an elimination can be satisfactorily effected by filtration through granulated charcoal which has been recently heated.—About three fifths of the products of distillation in the United States are what are termed high-wines or whiskey, containing about 75 per cent. of alcohol. This, as it comes from the still, contains a good deal of fusel oil. Some of it is made into cheap whiskey, and the remainder is rectified and redistilled into French spirit. When the percentage of alcohol is high it forms Cologne spirit. About one fifth of the products of distillation is alcohol, which is all used for manufacturing and mechanical purposes, about 6,000 barrels being exported from the United States monthly. The remaining

one fifth of the distilled liquors consists of whiskey and rum, distilled to about proof, and so left to ripen with age. Considerable whiskey is made from rectified spirits of about 75 per cent. alcohol, which is reduced and flavored by the addition of raw whiskey not rectified. All distilled liquors are sold by the gallon, according to the proof. Proof spirit is reckoned by the government as 100, which is 50 per cent. absolute alcohol.

**DESTRUCTIVE DISTILLATION.** When organic bodies are excluded from the air and subjected to heat, they undergo decomposition, and the constituent atoms or molecules rearrange themselves into new compounds. The causes of this are various, and depend much upon the conditions which are present. The elective affinities of atoms and molecules, when a variety of substances are mingled together, vary with the heat and with the nature of the substances with which they are surrounded. Two or more elements united in a compound, requiring a certain degree of heat to separate them, will require less when another compound is present, the amount depending upon the affinity which a constituent of one compound may have for a constituent in the other. Organic bodies, which are usually composed of several compound constituents (as woody fibre, starch, resin, oils, and water), very readily suffer a complete change in their chemical as well as their organic structure by the simple application of heat, and without the presence of a supporter of combustion. When wood is enclosed in an iron tube and subjected to heat, various new bodies are formed of an inorganic character, and of a composition and number depending upon the duration and degree of heat. Decomposition commences at about 284° F.; and between this and red heat various gases, vapors, liquids, and solids are produced. The products of the lowest temperature contain the most oxygen, as water and carbonic and acetic acids. As the temperature rises bodies containing less hydrogen are formed, such as wood spirit, acetone, and creosote. At a still higher temperature, hydrocarbons, such as toluene, xylene, eupione, and paraffine, appear; and as the temperature approaches redness, hydrogen is abundantly formed. By connecting the retort with condensing vessels, by means of good-sized exit tubes, the various volatile products may be collected, and subsequently separated by fractional distillation and otherwise. The manufacture of illuminating gas illustrates the destructive distillation of bituminous coal on a large scale. The products may be divided into three classes, viz.: 1, coke, consisting of carbon, sulphuret of iron, and ash; 2, ammoniacal liquor, containing carbonate, sulphide, chloride, cyanide, and sulphocyanide of ammonium; 3, tar, embracing a great variety of solid and fluid hydrocarbons and acids, among which are benzole, toluole, xylole, naphthaline, anthracene, and carbolic or phenic, oxyphenic, and cresylic acids, together

with creosote, a compound of homologous oxyphenic and methylic acids; also several bases, as aniline, irridoline, and rubidine; 4, illuminating gas, containing light-yielding compounds, such as acetylene,  $C_2H_2$ ; ethylene, or olefiant gas,  $C_2H_4$ ; benzole,  $C_6H_6$ ; naphthaline,  $C_{10}H_8$ ; propyle,  $C_3H_6$ ; butyle,  $C_4H_{10}$ ; mingled with hydrogen, carbonic oxide, and impurities, such as carbonic acid, ammonia, cyanogen, sulpho-cyanogen, and sulphuretted hydrogen. These processes involve highly complex reactions, the many stages of which are yet imperfectly understood. The destructive distillation of acids and the simpler bases are more easily understood, the products being often readily traced to their origin. The decomposition of the acids takes place differently according as they are separate or in the presence of bases. When distilled alone many undergo a simple elimination of carbonic acid, with the formation of a pyro-acid. Thus, gallic acid, when heated in a close vessel to 419° F., is decomposed into pyrogallic and carbonic acids, as follows:

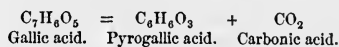

Other reactions are not quite as simple. Thus, oxalic acid yields water, carbonic acid, carbonic oxide, and formic acid, as follows:

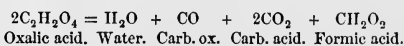

As an example of the destructive distillation of a salt, may be taken that of acetate of lime, which is converted into acetone and carbonate of lime, thus:

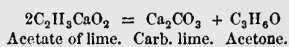

—**FRACTIONAL DISTILLATION** is the separating of different constituents which naturally exist or have been artificially produced in a mass. This is accomplished quite readily on account of the different temperatures at which the various constituents pass into vapors. The refining of petroleum is an example of fractional distillation. (See **PETROLEUM**.)

**DISTRESS** (Lat. *distringere*, to press, straighten, wring out), a term applied to the taking of property of a tenant for non-payment of rent; to the seizing of cattle for damage done by them; to a levy upon property to enforce the payment of taxes; and lastly to a proceeding to compel the appearance of a party who cannot be found. In the two cases first mentioned, the landlord or person who had been injured could make the seizure himself or by his deputy; an anomalous authority, entirely at variance with a fundamental principle of law that parties should not be permitted to redress their own injuries without judicial process. The recaption of property which has been wrongfully taken away, or wrongfully detained, or the reentry upon lands of which a man has been dispossessed, though analogous in one respect to distress for rent or *damage*

*feasant*, yet differs in another, viz.: that such recaption or reentry cannot be made with force, whereas a distress may be executed in like manner as process upon a judgment; that is to say, force may be used in case of resistance. The third case above mentioned, viz., distress to enforce the payment of taxes, is statutory, and while generally limited to the seizure and sale of the goods of the person taxed, it is sometimes, in the case of tax upon lands, permitted to extend to any personal property found thereon. The case of distress to compel an appearance was by a judicial writ called a *distringas*. In a popular sense, a distress is understood only of the taking property of a tenant or wrong doer in satisfaction of rent or damages. The term is with some incongruity applied as well to the property taken as to the act of taking. Formerly, the property distrained was deemed a mere pledge, and the distrainer had no power over it except that of detaining it till he received satisfaction of the rent or damages for which the distress was made; but for the security of the owner it was required that the property should be kept in a pound (*parcus*, which signifies any enclosure); and if the distress consisted of live animals, it was required that they should be impounded within three miles of the place where they were taken. If put into a public pound, the risk and expense of keeping the same devolved upon the owner without notice from the distrainer. By statute 11 George II., c. 19, the distrainer was authorized to make a special pound upon the premises where the distress was taken, in which case notice to the owner was required; but the liability to provide necessaries for animals belonged to the owner as in the other case. A distress of chattels which might be injured by exposure to the weather the distrainer was bound to keep in a pound covert. A distress was allowed only by daylight, except in the case of beasts *damage feasant*, which might be taken at night, lest they should escape. Formerly the landlord could distrain only such goods as were found upon the premises for which rent was due, but by statute goods which have been clandestinely removed may be followed within 30 days after the rent accrues. In making the distress the landlord is not permitted to break open the outer door of the house, but being once in, he can break an inner door; being the same rule as in levy upon execution. As to the property subject to distress, it may be said in general that anything found upon the premises may be taken, whether the property of the tenant or not; but from this are excepted things affixed to the freehold and constituting a part of it in law; perishable articles; goods of third persons upon the premises from necessity, or for the purposes of commerce or trade, as the carriage of a traveller at an inn, or the plough at a smith's for repair; goods already in the custody of the law; and goods specially exempt

by statute. The tools or implements of a man's employment are also at common law conditionally exempt; that is to say, they should not be taken if other sufficient distress can be found. If distress is made when no rent is due, the tenant has his remedy by replevin; but for an excessive distress, the only protection of the tenant is by an ancient statute (52 Henry III., c. 4), under which an action may be brought for the taking of an unreasonable or excessive amount. After the impounding of the property, by the ancient law the remedy of the distrainer ceased; but by various modern statutes, when the distress is for rent, it may be sold after the expiration of five days for payment of the rent.—In the United States a strong inclination has of late been manifested to abolish distress entirely, not only as a harsh remedy as regards the debtor, but because establishing an unjust discrimination in favor of the landlord as against other creditors. In several of the states this has already been done.

**DISTRICT OF COLUMBIA**, a territory of the United States, containing the national capital. It is about 200 m. from the ocean by the Potomac river and Chesapeake bay, and lies between lat. 38° 51' and 39° N., and lon. 76° 58' and 77° 6' W. It was named in honor of Christopher Columbus, and also with some reference to the poetical use of the term Columbia as a designation for the United States. It is bounded on the S. W. by the Potomac, and on all other sides by Maryland, and is 10 m. long from N. W. to S. E., with an area of 64 sq. m. It formerly constituted the county of Washington, that term, however, being popularly confined to the portion outside of the cities of Washington and Georgetown, forming much the larger part of the District. The following table shows the population at the several decennial enumerations:

CENSUS.	CENSUS.			Total.
	White.	Free colored.	Slave.	
1800.....	5,072	400	2,072	8,144
1810.....	10,345	1,527	8,554	15,471
1820.....	16,058	2,758	4,520	23,336
1830.....	21,152	4,604	4,505	30,261
1840.....	25,926	6,439	3,820	35,745
1850.....	37,941	10,059	3,987	51,687
1860.....	60,768	11,131	3,185	75,084
1870.....	68,278	43,404	.....	131,700

Included in the total for 1870 are 3 Chinese and 15 Indians. There were 31,622 male citizens of the United States 21 years old and upward; 115,446 were native and 16,254 foreign born; 62,192 were males and 69,508 females. Of the natives, 52,340 were born in the District, 23,596 in Virginia and West Virginia, 21,751 in Maryland, 4,597 in New York, 4,121 in Pennsylvania, 1,254 in Massachusetts, and 1,042 in Ohio. Of the foreigners, 8,218 were born in Ireland, 4,020 in Germany, and 1,422 in England. There were 15,207 persons born in the District living in other parts of the Union. Of the colored, 35,372 were blacks



and 8,032 mulattoes. There were 28,719 persons 10 years old and over unable to write, of whom 26,501 were native and 2,218 foreign; 4,876 were white and 23,843 colored; 11,418 were male and 17,301 female; 22,112 were over 21 years of age, and 6,607 between 10 and 21; of those over 21, 1,214 were white males, 2,542 white females, 7,599 colored males, and 10,757 colored females. There were 78 blind, 134 deaf and dumb, 479 insane, and 50 idiotic; 303 paupers received support during the year; and 145 persons were convicted of crimes. There were 25,276 families, averaging 5.21 persons, and 23,308 dwellings, averaging 5.65 persons to each. There were 1,365 persons over 10 years of age engaged in agriculture, 29,845 in professional and personal services, 6,126 in trade and transportation, and 11,705 in manufactures and mining.—The surface is undulating, with hills which command extensive views and afford fine sites for public edifices. Two considerable streams empty into the Potomac within the District, Rock creek and the Anacostia or Eastern branch. There are also several small brooks, to one of which the name of the Tiber was given in the 17th century, because a planter named Pope lived near it. The climate is moist and warm, and there is much local miasma. In the summer and autumn fevers prevail in some parts, especially in the low grounds near the Potomac. The mean temperature of Washington in spring is 54.2°, in summer 73.1, in autumn 53.9°, in winter 33.9; year, 53.8. The average rainfall in spring is 10.45, in summer 10.52, in autumn 10.16, in winter 11.07; year, 41.20 inches. The whole number of deaths in 1870 was 2,015, of which 826 were from general diseases, 280 from diseases of the nervous system, 80 of the circulatory, 237 of the respiratory, 356 of the digestive system, 77 from accident and injuries, and the rest from various causes. Consumption proved fatal in 442 cases, pneumonia in 123, and cholera infantum in 150. The soil is light and moderately fertile. In 1870 there were 8,266 acres of improved land. The productions were 3,782 bushels of wheat, 3,724 of rye, 28,020 of Indian corn, 8,500 of oats, 27,367 of Irish and 5,790 of sweet potatoes, 40 of peas and beans, 2,019 tons of hay, 126,077 gallons of milk sold, 900 of wine, and 4,495 lbs. of butter. There were 533 horses, 124 mules and asses, 657 milch cows, 144 other cattle, 604 sheep, and 577 swine; there were besides 5,496 horses and 1,000 cattle not on farms. The cash value of farms was \$3,800,230; of farming implements and machinery, \$39,450; wages paid during the year, including value of board, \$124,338; estimated value of farm productions, including betterments and additions to stock, \$319,517; of orchard products, \$6,781; of produce of market gardens, \$112,034; of live stock, \$114,916. There were 952 manufacturing establishments, with 54 steam engines of 789 horse power, and 15 water wheels of 1,100 horse power, em-

ploying 4,685 hands, of whom 4,333 were males above 16, 216 females above 16, and 136 youth; capital invested, \$5,021,925; wages paid during the year, \$2,007,600; value of materials, \$4,754,883; of products, \$9,292,173. The commerce, almost entirely domestic, is carried on chiefly through Georgetown. For the year ending June 30, 1872, there were entered in the coastwise trade 231 steam vessels of 109,681 tons, and 96 sailing vessels of 22,245 tons; cleared, 108 steamers of 69,308 tons, and 65 sailing vessels of 13,402 tons; registered, enrolled, and licensed, 419 vessels, with an aggregate tonnage of 26,623, of which 25, of 5,084 tons, were steam vessels; 103, of 2,987 tons, sailing vessels; 275, of 17,778 tons, canal boats; and 16, of 774 tons, barges. There were 31 vessels, of 1,352 tons, built during the year. The Chesapeake and Ohio canal passes through a portion of the District, and crossing the Potomac at Georgetown terminates at Alexandria. Branches of the Baltimore and Ohio railroad from Relay, and from Point of Rocks, Md., terminate in Washington, and a railroad connects Washington with Alexandria. The Baltimore and Potomac railroad connects Baltimore and Washington. There are 5 national banks with \$1,531,000 capital, 3 savings banks, 1 safe deposit company, 6 fire insurance companies with a capital of \$1,725,000, and 2 life insurance companies.—By the act of congress of Feb. 21, 1871, all the territory included within the limits of the District was erected into a government, by the name of the District of Columbia, which is constituted a body corporate, with the usual powers, for municipal purposes. The executive power is vested in a governor and secretary, appointed by the president, with the advice and consent of the senate, for four years; and in a comptroller, collector, auditor, treasurer, attorney, register, superintendent of assessments and taxes, water registrar, and surveyor, appointed by local authority. The board of health consists of five members, and the board of public works of four, besides the governor *ex officio*. There is a metropolitan police force for the District, under the charge of five commissioners, together with the governor *ex officio*. The commissioners and members of the boards are appointed in the same manner as the governor. A fire department has been organized by the territorial government. The legislative power is vested in an assembly, consisting of a council of 11 members, appointed by the president with the advice and consent of the senate, for a term of two years, and a house of delegates of 22 members, elected annually by the people. Two of the councilmen must be residents of and appointed from Georgetown, and two from that portion of the District outside of Georgetown and Washington. The territory is divided into districts for the appointment and election of councilmen and delegates. All male citizens 21 years of age, except convicts and those of unsound mind, who have resided one

year in the District and 30 days in the precinct where they offer to vote, have the right of suffrage. The assembly has power to divide the territory not included in Georgetown and Washington into not more than three townships, and is required to maintain a system of free public schools. The governor has a veto upon all legislative acts, which may be overcome by a two-thirds vote of each house. The supreme court of the District consists of a chief justice and four associate justices appointed by the president with the advice and consent of the senate, who hold office during good behavior, and has general original jurisdiction in law and equity, and appellate jurisdiction of judgments of justices of the peace. It is divided into a circuit court (having also the powers and jurisdiction of a circuit court of the United States) for the trial of civil causes by jury; a criminal court; a district court, with the powers and jurisdiction of a district court of the United States; and a special term for equity and probate matters; each of which is held by a single justice. The general term, held by all the justices or a majority of them, hears appeals and writes of error from determinations of a single justice. From final judgments and decrees of the supreme court a writ of error or appeal lies to the supreme court of the United States. Justices of the peace are appointed by the assembly, and have jurisdiction of minor cases. The salaries of all officers appointed by the president are paid by the United States; the other officers are paid from the local treasury. The property of a married woman, not received by gift or conveyance from her husband, is not subject to his control nor liable for his debts, and she may dispose of it in every respect as if single. The valuation of property, according to the federal censuses, has been as follows:

for the 31 months from June 1, 1871, the date of the organization of the territorial government, to Dec. 31, 1873, were as follows:

RECEIPTS.

Loans and bonds.....	\$6,427,850 00
Licenses, markets, and miscellaneous.....	1,068,949 06
Special and personal accounts.....	446,642 84
Trust funds.....	897,975 49
General taxes.....	1,006,206 21
School taxes.....	688,837 26
Police taxes.....	255,241 45
Gas taxes.....	244,500 98
Personal taxes.....	37,316 52
Total on account of District of Columbia..	\$11,088,519 71
Total on account of the late corporations of Washington, Georgetown, and the levy court.....	\$3,068,906 07
Total from all sources.....	\$14,157,425 78

EXPENDITURES.

Account of loans and bonds.....	\$6,898,416 60
Salaries of general officers, and general contingencies.....	800,959 09
Special and personal accounts.....	407,859 79
Trust funds.....	576,585 73
Salaries of local officers, and local contingencies, Salaries of officers, teachers, and contingent expenses of public schools.....	405,887 46
Salaries of officers and members, and contingent expenses of metropolitan police.....	657,195 65
Gas for street lamps.....	244,558 99
Miscellaneous.....	187,646 49
	1,002,760 85
Total on account of District of Columbia..	\$10,681,120 70
Total on account of the late corporations.....	2,682,074 41
Total on all accounts.....	\$13,363,195 11

Included in the expenditures on account of the late corporations is the sum of \$215,948 20 for the completion of public school buildings and the proportion due to colored schools, making the whole amount expended for school purposes \$873,143 85. The expenditures to Dec. 31, 1872, included \$4,833,009 30 on account of the board of public works, \$53,199 25 for the board of health, \$450,000 for an additional supply of Potomac water, \$186,330 57 for interest, and \$109,051 58 for the fire department. The tax levy for the year ending June 30, 1874, was \$2 in Washington city and Georgetown, and \$1 58 in the county of Washington, on each \$100 of taxable property, amounting to \$1,888,152 22 in all. The debt on Dec. 31, 1873, was \$9,878,039 91, of which \$5,527,850 belonged to the present District government, \$4,096,801 01 to the late corporation of Washington, \$251,689 to Georgetown, and \$1,699 90 to the levy court. The outstanding bonds issued by the present government amounted to \$8,213,850, viz.: permanent improvement bonds, \$4,790,000; funding bonds, \$2,686,000; water stock bonds, \$485,000; market stock bonds, \$140,900; Chicago relief bonds, &c., \$111,900. From 1797 to 1870 congress appropriated \$42,228,963 80 for various objects connected with the District of Columbia.—There are 22 important charitable and reformatory institutions. The following are those more or less directly connected with the territorial or national government, with the number of inmates, Dec. 1, 1872. The Wash-

YEARS.	ASSESSED VALUE.			TRUE VALUE.
	Total.	Real estate.	Personal estate.	Real and personal estate.
1850.....				\$14,018,874
1860.....	\$41,084,945	\$38,097,542	\$7,987,403	41,084,945
1870.....	74,271,693	71,437,468	2,834,225	126,873,613

At the last named date the total taxation was \$1,581,569, of which \$49,975 was county and \$1,531,594 city tax; there was a city debt of \$2,596,545, for which bonds to the amount of \$1,640,584 had been issued. The assessed value of real estate for the fiscal year ending June 30, 1873, was \$87,869,924; the valuation of Washington city was \$72,880,380; of Georgetown, \$6,366,488; of the county of Washington, \$8,623,056. The assessed valuation for the year ending June 30, 1874, was \$96,433,072. Personal property is not now assessed, but the comptroller, in his report of April 28, 1873, estimates the actual value of all property, including that of the federal government, at \$200,000,000. The receipts and expenditures

ington city asylum is supported by the District government and by the products of the farm attached, which is worked by the prisoners. It receives sick and destitute persons, and vagrants and petty criminals committed by the courts; it has from 50 to 200 inmates. The reform school for boys had 79 inmates, consisting of juvenile delinquents committed by the courts, and of destitute boys admitted on the order of the governor of the District or the trustees of the schools. Congress has recently appropriated \$100,000 for the purchase of a farm and the erection of buildings for this institution, and in August, 1872, it was removed from the vicinity of Georgetown to Mount Lincoln, 3 m. N. E. of the capitol, where 150 acres of ground have been purchased, upon which a building capable of accommodating 300 inmates has been erected. The national soldiers' and sailors' orphans' asylum, established in 1866, had 37 male and 31 female inmates; it receives only the orphans of Union soldiers and sailors, and is supported by annual appropriations by congress, and by voluntary contributions. The freedman's hospital, established in 1865, is supported by congress, which in 1872 appropriated \$74,000 for its maintenance; its inmates, who are admitted on the recommendation of the governor of the District, numbered 115 males and 110 females, all but 10 colored. The national soldiers' home, about 2 m. N. of Washington, was established in 1851 with the unexpended balance of the contributions levied by Gen. Scott during the Mexican war. It is supported mainly by a levy of 12½ cents on the monthly pay of soldiers of the regular army. Its inmates, superannuated and disabled soldiers, numbered 250. Congress also makes an annual appropriation in aid of the Columbia hospital for women and lying-in asylum, and of Providence hospital (Roman Catholic). The government hospital for the insane, situated S. of the Anacostia river, near Uniontown, was established in 1853 for the "curative treatment of the insane of the army and navy and of the District of Columbia." It contained 422 male and 139 female patients. The Columbia institution for the deaf and dumb was founded by Amos Kendall, and chartered by congress in 1857. It is supported by congressional appropriations, by the tuition fees of a few paying pupils, and by voluntary contributions. The amount appropriated by congress in 1872 was \$48,000 for the support of the institution, and \$70,000 for the purchase of additional grounds. It is designed especially for residents of the District and the children of soldiers and sailors. A collegiate department, known as the national deaf-mute college (the only such college in the world), was organized in 1864, and is designed to receive students from the deaf and dumb institutions of the various states. In 1873 it had 8 professors and 59 students, of whom 19 were semi-mutes. Including the above, the whole number of in-

structors in the institution was 11, and the whole number of pupils 108, of whom 16 were females. Columbian college (Baptist) was organized in 1822, and in 1872 had 27 professors and instructors, and 261 students. Howard university (Congregational), organized in 1866, is an outgrowth of the freedmen's bureau, designed especially for colored students, but is not restricted by its charter in respect of race or sex. (See HOWARD UNIVERSITY.) Gonzaga college (Roman Catholic), organized in 1858, had in 1872 9 professors and 107 students in the preparatory department. Wayland seminary (colored Baptist), organized in 1865, had 8 instructors and 85 students. The law school of the national university, organized in 1870 as a branch of a projected university, had 6 professors and 98 students. The national college of pharmacy has been recently organized with 3 professors and 17 students. The institutions mentioned above are in Washington. In Georgetown is Georgetown college (Roman Catholic), organized in 1789, a notice of which will be found in the article GEORGETOWN. Besides Georgetown and Washington, there are four post offices in the District, viz.: Anacostia, Brightwood, Mount Pleasant, and Tenallytown. The public schools are under the charge of four boards of trustees. One board, of 20 members, has control of the white schools of Washington city; the second, of five members, has control of the white schools of Georgetown; the third, of seven members, has charge of the schools both white and colored of the county of Washington. There is a superintendent for these schools, who, as well as the trustees, is appointed by the governor for two years. A board of three trustees, appointed by the secretary of the interior for three years, was constituted by act of congress in 1862. This board appointed a superintendent, and continued to have the management of the colored schools of Georgetown and Washington city until April 1, 1873, when the act of congress of March 3, 1873, went into effect, which created a board of nine trustees, appointed by the governor for three years (three of them retiring annually), for those schools, and provided for the appointment of a superintendent, a secretary, and a treasurer by the same authority. The public schools are entitled to "all moneys accruing from fines, penalties, and forfeitures for violation of the laws of the United States within the District of Columbia." The colored schools of Washington and Georgetown receive a proportion of all moneys devoted to school purposes in those cities, determined by the ratio which the colored children bear to the whole number of children of school age. The act of congress of June 25, 1864, requires parents and guardians, under penalty of a fine of \$20, to send their children between the ages of 6 and 14 years to some public school at least 12 weeks in each year, unless elsewhere educated. By the census of 1870 there were 31,671 children of school age (6 to

17 years inclusive), of whom 10,494 were colored, 14,971 were males, and 16,700 females. The following statements embody the statistics of the colored schools of Washington city and Georgetown for the year ending June 30, 1872, and of the other schools for the year ending Aug. 31, 1872: the number of school houses owned by the District was 42; value of school property, \$816,005; number of schools, 233, including 1 preparatory high school (colored), 16 grammar, 36 intermediate, 51 secondary, 111 primary, and 18 ungraded schools (county of Washington); number of teachers, 264, of whom 27 were males; pupils enrolled, 15,555, of whom 5,435 were colored; average attendance, 10,688, of whom 3,639 were colored. The school tax in Washington city was 60 cents on \$100, in Georgetown 25 cents, and in the county of Washington 40 cents. The receipts were \$3,398 64 from fines, &c., and \$352,241 43 from taxation; total, \$355,640 07. The total expenditures were \$479,995 94, including \$129,654 51 for teachers' wages, \$79,409 76 for incidental expenses, and \$140,577 51 for sites, buildings, &c. The separate expenditures (included in the total) of the colored schools of Washington and Georgetown were \$49,855 59 for teachers' wages, \$18,747 04 for incidental expenses, and \$60,403 68 for sites, buildings, &c.; total, \$129,006 31. The school tax for the year ending June 30, 1873, was 33 cents on \$100 in Washington city, 53 cents in Georgetown, and 50 cents in the county of Washington. According to the census of 1870, there were 87 schools not public, viz.: 1 classical academy, 2 commercial, 61 day and boarding, and 23 parochial and charity schools. The number of teachers was 256; pupils, 7,010; annual income, \$199,313. The number of private schools in 1872, as appears by the report of the United States commissioner of education, was 123 (including 31 institutions for secondary instruction), having 6,217 pupils. The census returns of 1870 include 696 libraries, containing 793,702 volumes, of which 569, with 383,766 volumes, were private. The others were classified as follows: 1 congressional, 190,000 volumes; 14 departmental (United States government), 115,185; 4 court and law, 32,348; 95 Sabbath school, 39,853; 6 church, 2,850; 7 circulating, 29,700; total libraries not private, 127, with 409,936 volumes. The number of newspapers and periodicals was 22, viz.: 3 daily, 1 tri-weekly, 12 weekly, and 6 monthly. There were 111 church organizations and 112 houses of worship; number of sittings, 63,655; value of property, \$3,393,100. The church edifices were: Baptist, 16; Christian, 1; Congregational, 1; Episcopal, 16; Evangelical Association, 1; Friends', 1; Jewish, 1; Lutheran, 10; Methodist, 36; New Jerusalem, 1; Presbyterian, 15; Reformed, 1; Roman Catholic, 11; Unitarian, 1.—After the adoption of the articles of confederation by the United States, the question of fixing upon a seat of government

for the Union called forth much sectional rivalry. During the period between the conclusion of the revolutionary war and the adoption of the present constitution, congress met at Princeton, Annapolis, Trenton, and New York. After the organization of the government under the constitution, March 4, 1789, warm discussions took place in congress on the location of the capital, which were finally settled by the passage, June 28, 1790, of an act containing the following clause: "That a district of territory on the river Potomac, at some place between the mouths of the Eastern branch and the Connogacheague, be and the same is hereby accepted for the permanent seat of the government of the United States." The same act provided that congress should hold its sessions at Philadelphia until the first Monday in November, 1800, when the government should remove to the district selected on the Potomac. The area fixed upon for the district was a square of 10 miles, or 100 square miles. It embraced 64 square miles of Maryland, constituting the county of Washington, which was ceded by that state to the United States in 1788, and 36 square miles of Virginia, constituting the county of Alexandria, ceded in 1789. The portion on the Virginia side of the Potomac was retroceded to that state in 1846. In 1814 Washington was taken by the British, who burned the capitol, presidential mansion, and congressional library. In the early part of the civil war strong fortifications were erected for the protection of the capital, which was several times threatened; but no fighting occurred within the District until July 12, 1864, when Gen. Early with a considerable force attacked Fort Stevens, an isolated work about 6 m. N. of Washington. At this time the garrison had been much weakened by the withdrawal of troops to strengthen the army before Richmond, but reinforcements arrived the same day, and the confederates were repulsed. Slavery was abolished by the act of congress of April 16, 1862, and the right of suffrage was extended to colored citizens by the act of Jan. 8, 1867. The constitution of the United States confers upon congress the exclusive legislative control over the District, but does not allow the inhabitants any vote for presidential electors. Previous to the act of 1871 the legislative power had been exercised directly by congress, in which, however, the people had no representation; but upon the establishment of a territorial form of government by that act the right of electing a delegate to congress, with the same privileges as delegates of other territories, was granted. The act repealed the charters of the cities of Washington (pop. in 1870, 109,199) and Georgetown (pop. 11,384), which had been incorporated May 3, 1802, and Dec. 25, 1789, respectively, on and after June 1, 1871; but provided that the portions of the District included within the then limits of those cities should continue to be known as the city of Washington and the

city of Georgetown respectively. At the same time the levy court of the District of Columbia ceased to exist, and the District of Columbia became the successor of the corporations of the cities and of the county of Washington. (See GEORGETOWN, and WASHINGTON.)

**DITHYRAMBUS**, in Grecian antiquity, a song sung in the vintage season in honor of Bacchus. The origin of these songs is traced to the earliest ages of Greek civilization, and the most famed of the early composers of them was Arion of Methymna. But few fragments of ancient dithyrambic poetry remain, and it is only by tradition that we know the successes of Melanippides, Pindar, and Philoxenus in this style of composition. The dithyrambus was primitively religious; it was lively, rapid, brilliant, and disordered, like the joy and intoxication of a Bacchanalian festival. In the heat of improvisation, the poets often united several words into one, from which resulted expressions so voluminous and sonorous that they wearied alike the ear and the imagination. In the age of Pericles this kind of poetry was the object of raillery.

**DITMARSH** (Germ. *Dithmarschen*, or *Ditmarsen*, *i. e.*, the German marshes), the westernmost portion of Holstein, Prussia, comprising the coast land on the North sea, between the Eider and the Elbe; area, 500 sq. m.; pop. about 75,000. The surface is a low flat, protected against inundation by strong embankments. Excepting in the marshy districts, it has a rich alluvial soil, bearing heavy crops of wheat, beans, and hay. The inhabitants are a sturdy people of the primitive Teutonic type, and during the middle ages maintained a considerable degree of autonomy and equality, bravely defending their rights against the encroachments of their various rulers, German and Danish. After severe struggles Ditmarsh became part of Holstein, under Danish rule, in 1559, but continued to be governed by its own code. In 1866 it was with the rest of Holstein annexed to Prussia.

**DITTON**, *Humphrey*, an English mathematician, born in Salisbury, May 29, 1675, died Oct. 15, 1715. He studied theology, and was for some years a dissenting clergyman, but subsequently devoted himself to mathematics. He was encouraged by Sir Isaac Newton, through whose influence he was elected professor in the newly created mathematical school of Christ's hospital, a position which he retained till his death. In 1714 he published with Whiston an advertisement of a new method of finding the longitude at sea. The plan was approved by Newton, but rejected by the board of longitude; and it is said that the chagrin caused by this disappointment, and by some obscene verses of Swift, occasioned his death. He was the author of numerous mathematical treatises, among which are the following: "Of the Tangents of Curves;" "General Laws of Nature and of Motion;" "An Institution of Fluxions;" and "The New Law of

Fluids, or a Discourse concerning the Ascent of Liquids in exact Geometrical Figures, between two nearly contiguous Surfaces."

**DIU**, a Portuguese island and town of India, separated by a narrow channel from the S. extremity of Guzerat, in lat. 20° 43' N., lon. 70° 45' E., 160 m. N. W. of Bombay; area, 12 sq. m.; pop. about 10,000. The soil is unfit for cultivation and the water is brackish, but provisions are plentifully supplied from the mainland, with which the inhabitants carry on a lively trade. The town is situated on the E. end of the island, is well fortified, and has an excellent harbor. It was renowned in ancient times for a magnificent temple of Mahadeva, which was destroyed by Shah Mahmood of Ghuzni about 1025. The island was taken in 1515 by the Portuguese, and was pillaged in 1670 by the Arabs of Muscat. It is at present one of the most flourishing of the Portuguese settlements.

**DIURETICS**, drugs used to increase the amount of the urinary excretion or of some of its constituents. They may be divided into several groups: 1, those which increase the water of the urine with but little effect on its solid constituents; 2, those which increase both the water and the solids; 3, those which increase the solid rather than the watery constituents; 4, those which alter the quality without augmenting the quantity. To the first class belong squills, juniper, taraxicum, horseradish, parsley, broom, carrot seed, spirits of nitrous ether, pure water, cantharides, and turpentine. Cantharides and turpentine may be given in such doses as to produce congestion of the kidneys and bloody urine. If their action is carried far enough, a suppression instead of an increase of the urine may result. Many salines, such as acetates, citrates, tartrates, and carbonates of soda and potassa, nitrate of potassa, and sulphate and citrate of magnesia, belong to the second class. Some of these salts may be given so as to pass off by the bowels, and exert but little effect upon the kidneys. In general, it is necessary to give this class of drugs in small doses, frequently repeated, when it is desired that they should pass through the kidneys and act as diuretics, and in one or two large doses when they are intended to act upon the bowels. Colchicum is the principal agent of the third class. According to Dr. Hammond's experiments, it has a powerful effect in augmenting the amount of solid urinary constituents, while the water is comparatively little affected. The salts formed by the alkalies with carbonic and vegetable acids render the urine alkaline when given in sufficient doses, and are consequently examples of the fourth group of diuretics. *Ura ursi* and *chimaphila umbellata* or wintergreen act as diuretics in virtue of the volatile oils and tannic acid which they contain, and which pass into the urine, imparting to it a dark color and peculiar odor. Buchu, copaiba, cubeb, and similar substances act by virtue of

their resins and volatile oil. Their therapeutic effect is due rather to the alterative action of the urine bearing these constituents on the mucous membranes by which it is excreted and over which it passes, than to any increase in its amount. Benzoic acid passes into the urine in the form of hippuric acid, and may be used when it is desirable to increase the acidity of that fluid. Digitalis, although frequently used as a diuretic, is probably only secondarily so. It increases the flow of urine by virtue of its action upon the arterial tension of the kidneys, promoting thereby a more rapid flow and even distribution of the blood through them. Digitalis is frequently combined with squill.—Diuretics are used in various stages of kidney diseases (where they should be very cautiously managed), in gout, rheumatism, dropsy, and affections of the urinary passages. Although very useful and efficient, in many cases, they cannot always be relied upon, and consequently are not regarded as among the most certain of medicines. It is well known that many wines, especially hocks and acid wines, are apt to run off by the kidneys. Ardent spirits, especially gin and whiskey, will also increase the urine, but neither wines nor ardent spirits are often prescribed as diuretics.

**DIVER** (*Colymbus*, Linn.), a bird of the order *natatores* and family *colymbidæ*, the latter containing the divers and the grebes. The bill in this genus is long, strong, straight, curved slightly at the tip, which is sharp, with compressed sides; the nostrils are in a membranous groove; the wings are moderate and pointed, the first and second quills the longest; the tail is very short and rounded; the tarsi rather short, compressed, and covered with reticulated scales; the toes long, the three anterior united by an entire web, and the inner side of the internal toe margined with membrane; the hind toe short, with a small membranous margin; the claws moderate, depressed, and broad. Only three species are well ascertained, the *C. glacialis*, *C. arcticus*, and *C. septentrionalis* (Linn.), which belong to the arctic circle, migrating to the northern temperate regions of America and Europe. The great northern diver, generally called loon in the United States (*C. glacialis*), is a large, powerful, and handsome bird; the largest males measure about 3 ft. to the end of the tail, with an extent of wings of nearly 5 ft., and a weight of from 8 to 10 lbs. The head is moderate, narrowed in front; the neck thick and long; the body elongated and depressed; the feet very far back; the plumage short and dense. The bill is black, iris deep bright red, feet grayish blue, with the webs brownish black; the head and neck are dark greenish blue, with purple reflections; on the throat there is a transverse white patch, with longitudinal dusky streaks; in the middle of the neck are two white patches, continuous behind, but separated an inch in front; the sides of the neck at the lower part are streaked longi-

tudinally black and white, there being on each feather two oblong spots of the latter hue; the upper parts are glossy black, with spots of white in regular transverse curved lines with

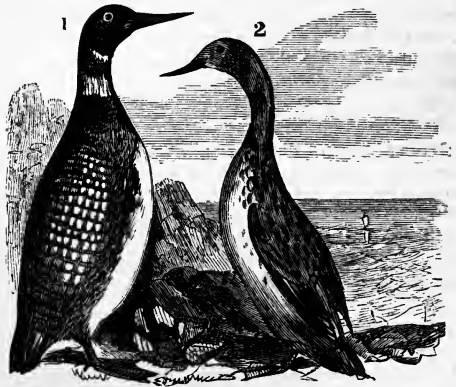

1. The Great Northern Diver (*Colymbus glacialis*). 2. The Red-throated Diver (*C. septentrionalis*).

the convexity backward, the spots being rounded and small toward the neck, sides, and tail coverts, larger and quadrangular on the middle of the back, largest on the scapulars; the lower parts are white, except on the sides under the wings, which are black with elliptical white spots, a faint dusky band across the vent, and the lower tail coverts, which are blackish, tipped with white; the tail is brownish black, with a paler tip. The female resembles the male in colors, but is smaller. The young in winter are dark grayish brown above, white underneath, with the sides dusky; toward spring the white spots begin to appear, and the plumage is that of the adult at the end of summer; they go further south than the adults. The flight is rapid, long sustained, and at a considerable elevation. The gait of the bird on land is generally slow and awkward; on the water, when at ease, it swims lightly, but when alarmed it sinks the body so deeply that not more than inch of its back can be seen. As a diver it is unsurpassed except by the darter and the ank, disappearing quickly, flying rapidly beneath the surface, remaining under water a long time, and coming up again at a great distance from the spot of its disappearance. Loons are occasionally found drowned in fishermen's nets, and are sometimes caught on hooks. The curiosity of the loon is often taken advantage of to draw them within shot, as the bird will almost always approach any bright-colored object waved by a concealed gunner; hence the phrase "stupid as a loon." Its notes are so loud and plaintive that to be "as noisy as a loon" has become a proverb. Its food consists of fish, lizards, frogs, aquatic insects, and the roots of fresh-water plants; it fishes in both salt and fresh water, and usually swallows its food beneath the surface. The flesh is tough and rank. The loon breeds

in various parts of the United States from Maine to Maryland, according to Audubon; and Dr. Richardson says it is found breeding as far N. as 70°. The nest is built near the water, in marshes, on the ground, and of rushes and grasses growing in the vicinity. The eggs are generally three, about 3½ in. long by 2¼ broad, elongated, with a narrow point; their color is dull greenish ochry, with indistinct spots of dark umber, most numerous toward the larger end. The loon is found also in Europe and northern Asia.—The black-throated diver (*C. arcticus*), next in size to the loon, is 29 in. long to the end of tail, with an extent of wings of about 40 in. The upper parts are glossy black, with a greenish tinge anteriorly and brownish behind, the head and hind neck being hoary; on the fore part of the back are two longitudinal bands of white bars, the feathers tipped with white; the scapulars and wing coverts with white spots; the quills are blackish brown, with a gray tinge externally; on the front of the neck for about six inches is a purplish black patch, ending angularly below, with a band of white spots above; the sides of the neck are blackish brown, with longitudinal white streaks; the lower parts are pure white, except a dusky band under the wings. The female is smaller than the male, but similarly colored. This species breeds in the far north, where the old birds principally remain, and whence the young wander over North America and northern and eastern Europe. Birds in full plumage are rarely obtained in the United States, and, according to Audubon, never further south than Delaware; along the eastern shores they are seen from autumn until spring. Their flight is rapid and well sustained, and performed with the neck and feet stretched out at full length.—The red-throated diver (*C. septentrionalis*) is about 26 in. long, with an extent of wing of 43 in., and a weight of 4 lbs. It resembles the preceding species except in the rich brownish red color of the anterior neck, and the lines of black and white on the hind head and neck; in the young males the foreneck is merely dotted with red. They begin to fly north to breed from early spring to the middle of May; they are found on the coast from Maryland to Maine, from autumn to spring; the younger the birds, the further south they go, and it is rare to find an old one south of Boston; they abound in the bay of Fundy. They are very shy, and always approach their nests from the water. Both sexes incubate. The full beauty of the plumage is not attained until the fourth year. They are rarely seen inland, and hardly ever out of the breeding season. Along the New England coast and in the bay of Fundy they are commonly called "cape racer" and "scapegrace."

**DIVI**, or **Divi-Divi**, the pod of a leguminous shrub, *Casalpinia coriaria*, a native of the northern parts of South America and the West India islands, used for tanning, for which purpose it is exported to Europe and other coun-

tries. The plant grows to the height of 20 or 30 ft., and the pods, which are dark brown, and curl up in drying, attain a length of 3 in. The rind has a strongly astringent and bitter taste from the tannin contained between the outer layer and the husk that encloses the seed. The leather prepared with it is very porous and acquires a deep brownish red color. Almost the only ports of shipment are Maracaibo, Rio Hacha, and Savanilla.

**DIVIDING ENGINE.** See GRADUATION.

**DIVINATION** (Lat. *divinatio*, from *divinus*, divinely or prophetically inspired), a general term for the various pretended arts of discovering secret or future things by preternatural means. These arts appear in the remotest antiquity, intimately connected with religion, furnished with rules, founded on mysterious principles, and fortified by the pretences of a science. Both as a learned doctrine and a popular faith, divination has always existed in the East, and was common in Europe throughout classical antiquity and during the middle ages. It was distinguished by the Greeks as natural or artificial; the former being a presage of future events by a sort of inspiration which was possible only to persons specially favored by the deity; the latter being founded on careful observation of certain natural phenomena which were believed to have mysterious relations with future events. Astrologers, augurs, sorcerers, fortune tellers, and second-sighted persons are eminent examples of diviners. The following are among the principal of the numerous forms of artificial divination practised in antiquity: Alectryomancy was practised by drawing a circle and dividing it into 24 equal parts, into each of which were put a letter of the alphabet and a grain of wheat; a cock was then placed in the centre, and the letters, being put together in the order that the grains were eaten by it, made a word which solved the question of the diviner. Arithmomancy depended upon the secret operation of numbers and magical squares, and the numerical value of letters; it was practised by the Chaldeans, and formed a part of the doctrine of the Pythagoreans, Neo-Platonists, and cabalists. Axinomancy consisted in suspending an axe from an upright stick, and the names of suspected persons being pronounced it was supposed to indicate the guilty by its motion. Belomancy consisted in the choice of arrows by chance from a bag containing many of them inscribed with various responses; it was in use especially among the Arabians. Capnomancy consisted either in observing the direction taken by smoke, or in inhaling the smoke of victims, which was believed to produce prophetic inspiration. Daetylomancy was practised by enchanted rings, or rings that were made in harmony with the position of the celestial bodies. Its origin is attributed to Helen, the wife of Menelaus. It is by one of these rings that Gyges is said to have rendered himself invisible. A

favorite method was to suspend the ring by a hair within a goblet, when it began to swing, the motion gradually increasing till it struck the vessel once or twice for yes or no, as previously determined. Gyromancy consisted in walking round in a circle, the circumference of which was marked with letters, the presage being drawn from the letters on which the inquirers stumbled when they became too dizzy to stand. Hydromancy, or divination by water, consisted in observing the colors and images presented by water in a vase, either when motionless or when disturbed by dropping little stones into it. The motions of the agitated waves of the sea were also studied for purposes of divination, especially by the ancient Sicilians and Eubœans. Lampadomancy furnished presages for the future from the form, color, and fluctuations of the flame of a lamp. Lithomancy was a method of divination by means of precious stones. The sounds of stones striking each other gave presages, and the amethyst was believed to have the virtue of sending prophetic dreams to whoever possessed it. The *batylia*, or animated stones, of which the Greeks learned from the Persians, and which were believed to bear oracles, are celebrated instances. Ornithomancy, or divination from the flight and song of birds, was a principal function of the Roman augurs. (See AUGUR.) The flame of fire (pyromancy), the accidental opening of a book (rhapsodomancy), the combination of cards (chartomancy), the drawing of lots, the dropping of staffs or observation of cups (especially in use among the old Egyptians), the interpretation of dreams, the reflections of mirrors, and the contortions of serpents, are other means. Several of these methods of divination are yet in use among the superstitious.—Some of the more remarkable forms of divination are treated in special articles, as ASTROLOGY, CHIROMANCY, DIVINING ROD, and MAGIC.

**DIVING.** Though the natural constitution of man entirely unfits him for remaining under water with safety for more than a few moments, the desire of obtaining valuable articles lying at the bottom of the sea, as well as the necessity for the execution of certain manual operations in civil engineering, has led him to devise numerous expedients by which he is enabled to lengthen his continuance at moderate depths. It has been said that the pearl divers of Ceylon can remain under water six minutes, but this is hardly credible; and Admiral Hood, who took pains to time their diving, found that they were under water in no instance more than a minute. The instance narrated by Dr. Halley of a Florida Indian diver at Bermuda, who could remain two minutes under water, is regarded as an extreme case. In Franchère's "Narrative of a Voyage to the N. W. Coast of America," mention is made of the feats of diving of the Hawaiian islanders. Two of them were induced to go down in 14 fathoms of water in search of two sheaves

lost overboard. They went down several times, each time bringing up shells as a proof that they had been to the bottom. "We had the curiosity to hold our watches while they dove, and were astonished to find that they remained four minutes under the water. That exertion appeared to me, however, to fatigue them a great deal, to such a degree that the blood streamed from their nostrils and ears. At last one of them brought up the sheaves, and received the promised recompense, which consisted of four yards of cotton." Statements are made by others which render it probable that the time may be somewhat extended beyond that observed by Admiral Hood, or even by Dr. Halley. The lungs retain at each ordinary expiration considerable carbonic acid. By breathing deeply for a short time the quantity is lessened, and the blood becomes more than usually aerated and capable of performing its functions for a longer time than usual without renovation. It is told of Brunel that, wishing to examine a break in the Thames tunnel, he was lowered with another person in a diving bell to the depth of 30 ft., and the brake not permitting the bell to descend further, he dived into the water, holding a rope in his hand. He found no great difficulty in continuing under water fully two minutes, which is explained by the circumstance that the air in his lungs had been condensed in the bell to but little more than half its ordinary bulk, and therefore was capable of supplying much more oxygen. The pressure exerted by the water is not only felt in the lungs but upon all parts of the body to a sensible degree. At a depth of 17 ft. it amounts to about  $7\frac{1}{2}$  lbs. to every square inch of surface, and increases about 0.44 of a pound



FIG. 1.—The Diver.

with every additional foot of depth.—To enable the diver to stay a considerable time under water, a dress called a diving armor is now generally employed for the laying of foundations and attaching apparatus for raising sunken vessels, and also by pearl and coral divers. Such a one is now (1874) in use in the construction of the foundations of the piers at the Battery in New York harbor. The diving dress or armor consists of a copper helmet, shown in fig. 1, tinned inside, and supplied with thick glass windows, and a copper breastplate which has a collar, to which the helmet is readily adjusted. The helmet is large enough for considerable rotation and lateral motion of the head, and allows



the air which is forced into it to be so diffused as to be breathed without inconvenience. The breastplate permits a free expansion of the lungs and sufficient motion to avoid constraint of the muscles. To the lower part of it is attached an India-rubber dress, having a body, legs, and arms; shoes are fitted on, and the whole is impervious to water. The central window of the helmet can be readily removed without removing the helmet. Lead weights are attached to the waist and soles of the shoes to enable the diver easily to maintain an erect position when standing or walking upon the bottom. A pump, shown in fig. 2, which is usually supplied with three cylinders, forces air through a flexible but strong India-rubber tube into an opening in the back of the helmet, which leads through a flat channel to the frontal portion, where it is delivered against the

glass windows, thus serving not only to supply the lungs of the diver, but to clear the moisture from the inner surface of the windows. The air finds its exit also at the back of the helmet. The air from the pump is free to pass down the waist and into the legs, between the person and the dress, and is delivered with sufficient force to overcome slightly the hydrostatic pressure. Fig. 2 represents the diver in the act of spreading a large bucket of hydraulic concrete upon the bed of a harbor, preparatory to laying blocks for the foundations of a pier. A signal rope communicates with an attendant on a boat which contains the air pump. The signals of the diver are communicated verbally by the attendant to a director stationed upon the derrick by which the buckets of concrete or blocks of *béton* are moved into position, and by him bells are rung which enable the atten-

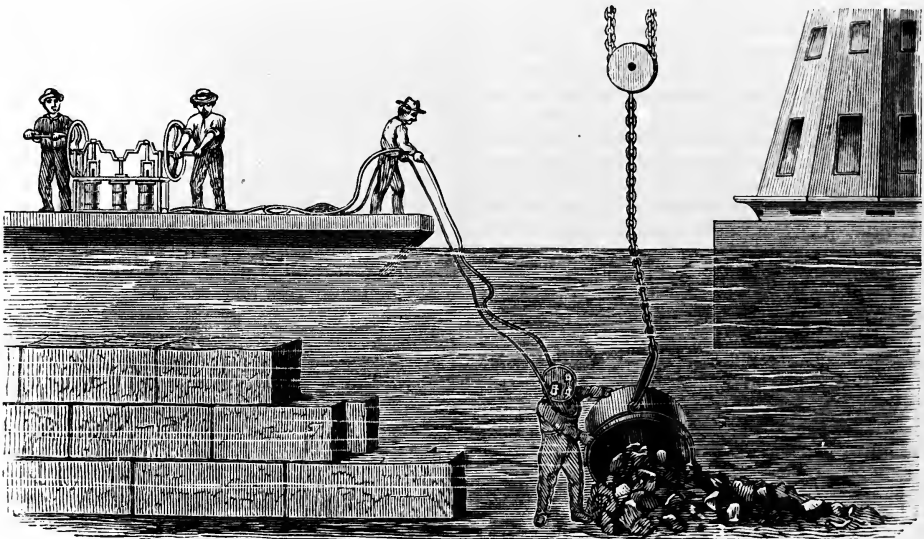

FIG. 2.—The Diver spreading Concrete.

dant at the engine to execute the necessary movements. In 1856 Mr. E. P. Harrington of Westfield, N. Y., recovered the iron safe of the steamer *Atlantic*, sunk four years previously in Lake Erie in about 170 ft. of water. The safe itself was at the depth of 157 ft. He used a common flexible India-rubber armor, unprotected with metal, and supplied with air sent down from a pump through a tube of  $\frac{3}{4}$ -inch bore, composed of nine alternate layers of canvas and rubber, with a copper wire coiled inside to prevent collapse. He also wore shoes of lead, and carried weights of lead amounting in all to 248 lbs. His first descent was on June 19, and the 18th and last was on the 22d, when he succeeded in attaching a line to the safe, which was in a state room on the upper deck, and it was hauled up. The time of his remaining below increased from one minute at the first descent to 11 minutes at the last. At the

depth of 50 to 70 ft. all light disappeared. He suffered from extreme chilliness; his strength too, he thought, was diminished nine tenths. The pressure sometimes caused a violent rush of blood to the head, and the appearance of bright flashes like electrical sparks.

**DIVING BELL**, a hollow inverted vessel, in which persons may descend to considerable depths, fresh air being forced down from above to supply the amount required for breathing, and under which upon the bottom they may work to prepare foundations, or to secure articles of value. The principle of the diving bell is seen in pressing any vessel like a tumbler mouth downward into water. The air within the vessel prevents the water from rising and filling it, but it is made to occupy less space as the pressure is increased with the increasing depth of the water. If the vessel were forced down to the depth of 33 ft., the

water would half fill it. Such is the simplest form of the diving bell, as it was known probably in the time of Aristotle, mention being made that divers at that period took down with them a kind of kettle to enable them to remain longer under water. During the reign of Charles V. a satisfactory experiment was tried by two Greeks at Toledo, in Spain, in the presence of the monarch and his court, of descending in a large inverted kettle into the water with a burning light, and coming up dry. But in this experiment, made by order of Charles to prove the possibility of the thing, and in others also undertaken for practical purposes (as recovering sunken treasure) in the course of the succeeding 200 years, there was no provision for renewing the supply of air as it became exhausted, nor for keeping the vessel free from the water forced by the pressure to rise within it. About the year 1715 Dr. Halley contrived a method of furnishing air to the bell while it was at the bottom. He had two tight barrels prepared, each with an open bung below, and a hose attached to the top long enough to reach outside below the bottom, in which position the air could not escape through it. These, loaded with weights, were sunk alternately, like two buckets in a well, or, by guys attached to the bell, were made to drop alongside of it. A person within, reaching out into the water under the mouth of the bell, could draw in the hose and raise the end of it above the level of the top of the cask, when the air would be forced upward and furnish a new supply to the bell. All the water would thus be displaced, and one could step about upon the bottom over the area covered by the bell. The air contaminated by breathing was let off by a stopcock in the roof, and pieces of glass set in here admitted the light. In the apparatus thus prepared Dr. Halley descended with four others, and remained an hour and a half in water more than nine fathoms deep. He soon afterward devised an apparatus with which one could leave the bell and walk on the bottom for a considerable distance. The diver was furnished with a heavy metallic cap, which was connected with a long flexible tube for conveying air within the bell. Heavy weights were attached to his belt and also to the feet to counteract the buoyancy of the body at great depths. Numerous modifications in the construction of the bell continued to be made by others, none of which proved to be of much importance until the engineer Smeaton applied the air pump about the year 1779 to forcing down the air, and made the first application of the apparatus to engineering purposes. In 1788 he constructed a bell of cast iron, in the form of a chest,  $4\frac{1}{2}$  ft. long,  $4\frac{1}{2}$  ft. high, 3 ft. wide, and weighing  $2\frac{1}{2}$  tons, so as to sink by its own gravity.—The most practical form of diving bell is called the nautilus, which is a sort of submarine boat whose lateral as well as vertical movements are controlled by the occupants. It is con-

structed with double sides, sufficiently far apart to form either air or water chambers, as it may be required to ascend or descend. In descending, they are supplied with water enough to cause the machine to sink. In ascending, the water is forced out by an air pump, worked on shore according to signals. It may be given considerable buoyancy, depending upon its size, and heavy weights may be raised with it. A plate is adjusted to the bottom, which may be removed at pleasure, air being pumped in to balance the hydrostatic pressure. Cables, worked by windlasses inside, pass out through holes surrounded by water-tight stuffing boxes, and are made fast at convenient distances. These enable the occupants to move the nautilus in any desired lateral direction. A man-hole at the top, conveniently closed by a cap, permits entrance or exit of the operators. The tube which connects with the air pump above water is used for forcing air either into the

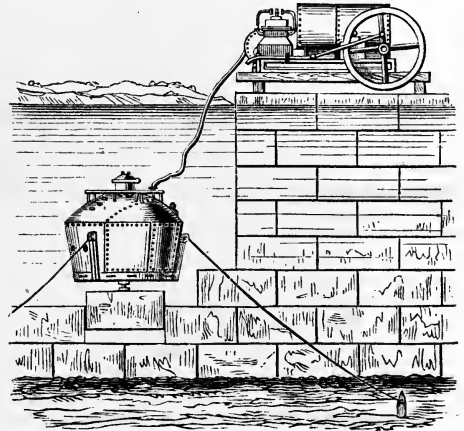

The Nautilus.

water chambers or into the central chamber. Pipes with stopcocks readily enable the change to be effected.—The increase of pressure experienced in descending in a bell affects individuals differently. Usually a pain is felt upon the tympanum of the ear, caused by the pressure upon the outside not being at once counterbalanced by the air within the tympanic cavity having acquired the same density. The construction of the Eustachian tube, leading from the mouth to the internal part of the ear, is such that a little time is necessary for the compressed air to make its way within. This usually takes place by a sudden impulse, which may be hastened by an effort of the individual like that of swallowing, the mouth and nostrils being closed at the time.

**DIVINING ROD**, an implement used by pretenders who undertake to discover water or minerals hidden in the ground. Its use has been traced as far back as the 11th century; and there are still many who believe in its efficacy. As commonly used, the divining rod

is a forked slender stick of witch hazel; elastic twigs, however, of any sort, or even two sticks of whalebone fastened together at one end, are sometimes employed. One branch of the twig is taken in each hand between the thumb and fore finger, the two ends pointing down. Holding the stick in this position, the palms toward the face, the operator passes over the surface of the ground; and wherever the upper point of the stick bends over and points downward, there he affirms the spring or metallic vein will be found. Some even pretend to designate the distance below the surface according to the force of the movement, or according to the diameter of the circle over which the action is perceived, one rule being that the depth is half the diameter of this circle; whence the deeper the object is below the surface the further is its influence exerted. The experiment being tested by digging; if water is found it proves the genuineness of the operation; if it is not found, something else is, to which the effect is attributed; or it is declared that the water which attracted the rod is sure to be met with if the digging is continued deep enough.

**DIVISIBILITY**, one of the general properties of matter, usually classed with impenetrability, extension, &c. The proposition that there is no limit to the mathematical subdivision of matter is universally admitted; but the question in its relation to physical science is a different one, and its treatment depends upon the adoption of one of two theories. Formerly it was not infrequently supposed that matter is continuous; at least, the idea that it consisted of ultimate atoms of a definite magnitude, and therefore that each body was composed of a certain limited number of them, was not entertained. According to the old doctrine of the homogeneity of matter, therefore, its divisibility physically could only be limited by the means employed, and in a theoretical point of view was logically considered as infinite. But the doctrine of Dalton in regard to definite and multiple proportions has been so well established by the investigations of chemistry, and researches into the molecular constitution of matter, particularly gaseous bodies, that physicists now generally hold that the subdivision of matter is limited physically, that at last the atoms become separated from one another, and these being the primordial particles, no conception can be formed of any subdivision of them. As examples of the great extent to which subdivision may be carried without arriving at the ultimate atoms, or even at the molecules of which they are composed, may be taken the spinning of the spider's web, which contains 4,000,000 fibres, which of course are composed of organic molecules of a compound structure, spun together within the diameter of a human hair; the odor of musk, which may pervade a room for years by the exposure of only a single grain; and the extent to which sulphuret of lead may be diffused by adding together solutions of almost infinitesimal quan-

ties of a salt of lead and sulphuretted hydrogen. Dr. Thomson in this way obtained sulphuret of lead in quantities sensibly appreciable, but which must, according to his computations, have been divided into at least 500,000,000,000 parts; and yet it is uncertain whether this division extended to the binary molecules of the substance. The most striking examples, however, of the extent to which matter may be divided, and at the same time manifest its presence by the exhibition of a degree of energy, are furnished by the experiments of Tyndall with minute quantities of gases, vapors, and perfumes, in which he exhibits their influence upon the diathermancy of atmospheric air and the elementary gases. He found that a quantity of watery vapor so small as to be inappreciable by any other test would increase the absorptive power of dry air to the obscure rays of heat to such an extent as to cause a marked difference in the deflection of the needle of a galvanometer. The equality which he has also established as existing between the diathermancy of the elementary gases and their mechanical mixtures, indicating that their elementary particles assume uniform and therefore definite wave vibrations, when in a free state they are subjected to the action of uniform heat waves, has thrown so much light upon the subject of molecular physics that the conclusion that elementary atoms or primordial particles limit the divisibility of matter cannot be resisted.

**DIVORCE**, a dissolution of the bond of matrimony for cause occurring after marriage. In popular language, however, and often in judicial discussions and statutes, another class of cases is included, namely, those in which a marriage is annulled for antecedent causes rendering it void or voidable. The common law allowed divorces *causa impotentia seu frigidity*, if such impotence or frigidity existed before marriage, this being deemed a fraud; but it was no ground of divorce if it supervened after marriage; and it is the only kind of fraud of which we find mention in the English cases as a ground of annulling a marriage. Fraudulent representations by either party in respect to his or her condition in life, pecuniary circumstances, family connections, bodily health, and the like, however material these may have been in inducing a consent to the contract, still are unavailable as an impeachment of the marriage. A false personation of another, or any fraud by which one of the parties is deceived in respect to the person with whom the marriage is solemnized, is a sufficient cause for annulling the marriage; but this is put upon the ground of want of consent, it being equally essential to this as to other contracts that there should be the *animus contrahendi*, and the contract cannot take effect contrary to the real intention of the party who is to be bound. In the English courts the proceeding *causa jactitationis matrimonii* was intended for relief in such cases; in form, being an action by the

one party for an alleged assertion by the other that a marriage has taken place, whereupon the matter is tried, and unless the defendant proves that there was a marriage he is prohibited from averring the same, which is equivalent to a decree that there was no such marriage. A marriage accomplished by force may be annulled at the option of the party wronged, and so might a marriage one party to which was under the age of consent, or where the parties are within the prohibited degrees of consanguinity or affinity, or where one already has a wife or husband living from whom he or she is not divorced. In these cases judicial proceedings are not necessary, but they are permitted on grounds of prudence and propriety, and in order that any question which might be the subject of dispute may be conclusively determined. The nature of the fraud that shall invalidate a marriage it is not easy to define; but it may safely be assumed that it must be something entering into the very essentials of the relation, such as deception in respect to the person with whom the ceremony is performed. It has been held in some cases that if the woman, without the man's knowledge, is pregnant at the time of the ceremony, this is such a fraud as justifies a decree of nullity; but ante-nuptial unchastity is not sufficient, nor fraudulent representations in respect to other matters which may have constituted the inducement to the consent. Voluntary cohabitation as husband and wife is a bar to dissolution of the marriage, either for force or fraud, and it validates a marriage entered into before the age of consent, if continued after both parties have reached that age. In the English ecclesiastical courts there was formerly another ground upon which marriage could be annulled, viz., a prior engagement with another party. But this was abrogated by statute 26 George II., c. 33, which prohibited all suits to enforce performance of a marriage contract, the parties being thus left to an action for damages upon refusal to perform it.—We have next to consider divorce for causes occurring after marriage. Under the Hebrew law, it seems that the husband might put away his wife at will, giving her a bill of divorcement, and the divorced wife was then at liberty to marry again. An exception to the liberty of divorce was made of husbands who had deflowered their wives while unbetrothed virgins, and husbands who slandered the ante-nuptial chastity of their wives. Among the Greeks at an early day wives appear to have been bought and sold, and in later times divorce was substantially at the pleasure of either party, though a judicial form was gone through with. In Rome, for a long time, divorcees appear to have been opposed to public sentiment, and to have required the sanction of a council or court of the relatives of the parties. Later, when dissoluteness of life had become general, divorce was common, and was permitted to both parties, and resorted to for

any cause or upon any caprice. Julius Cæsar and Pompey each divorced two wives, and Cicero put away his first wife that he might marry another who was rich, a union which was more speedily dissolved. These were representative cases, and by no means exceptional. Things were no better under the emperors, though efforts were made to impose some restraints, which, however, referred mainly to forms. Long after the empire became nominally Christian, divorce was unrestricted if by mutual consent, and might be obtained without mutual consent, though if the cause assigned was deemed insufficient to justify it, the party obtaining it was visited with a pecuniary penalty in the adjustment of their property rights. By the law of Theodosius II., adopted substantially by Justinian, the justifiable causes of divorce to the wife were certain high crimes, including murder, treason, poisoning, assaults or attempts upon the life of the wife, intimacy with prostitutes, and adultery. The justifiable causes on the part of the husband were substantially the same, with the addition of passing the night out of his house, and visiting places of amusement without his consent.—The theory of the sacramental nature of marriage gradually took possession of the Christian world; and when the reformation of the 15th century began, it was the accepted doctrine of the church that no offence of either party justified a dissolution of the marriage covenant, leaving the parties, or either of them, at liberty to marry again. This doctrine was supposed to be derived from the New Testament, and was confirmed by the council of Trent; but the reformers, who also planted themselves in this regard upon the gospel, though differing among themselves, generally agreed in permitting divorce for adultery and malicious desertion. Both Luther and Calvin thought that, though adultery ought to be punished with death, yet as the civil laws did not so provide, it was not wise to prohibit the divorced adulterer from marrying again. It may be said generally that from the beginning of the reformation to the present time the liberty of divorce in Protestant countries has been steadily enlarged. In Prussia it is permitted for adultery, sodomy and other unnatural vices, malicious desertion, persistent refusal of marital intercourse, plots or practices endangering life or health, ungovernable temper, drunkenness, extravagance, &c., unless corrected after admonition of the judge; failure of the husband to support the wife, hopeless insanity continuing for more than a year, and, where there are no children, deliberate mutual consent. This is the extreme of liberality, and goes somewhat further than is permitted in any of the other German states. Holland and Scotland allow divorce for adultery and desertion. The civil code of France allowed divorce—1, for adultery of the wife, but not for adultery of the husband except when he brought a paramour or concubine into his own house; 2, to either party for

any outrage, cruelty, or grievous wrong inflicted upon him or her by the other party; 3, to either upon the condemnation of the other to an infamous punishment, which is elsewhere defined to be either imprisonment, banishment, loss of civil rights, or being placed in the public stocks; 4, by mutual consent, with other satisfactory proof that the continuance of the marriage would be insupportable. These provisions were rescinded in the religious reaction of 1816. A law was passed (May, 1816) effacing divorce from the civil code, and reestablishing the old law, which allowed only separation. Ineffectual attempts were made in 1831 and 1832 to repeal this law, and there is therefore at present no divorce *a vinculo matrimonii* in France.—In England, from a very early period, divorce *a vinculo matrimonii* was not allowed for causes subsequent, but only a separation *a mensa et thoro*, which did not authorize either party to marry again. This practice was derived from the canon law, which held marriage to be a sacrament, and that it could not be dissolved for any cause whatever. But by statute 20 and 21 Victoria, c. 85 (1857), divorce *a vinculo* is now allowed on the petition of the husband for the adultery of the wife, and on the petition of the wife when the husband has been guilty of incestuous adultery, rape, bestiality, or adultery accompanied by cruelty. Divorce *a mensa et thoro* is by the same act denominated a decree of judicial separation, and under that designation is allowed for the same causes as heretofore. A new tribunal, called the court for divorce and matrimonial causes, has been established, and the jurisdiction of the ecclesiastical courts has been entirely superseded in such matters, except the granting of marriage licenses. Before this statute, however, private acts of divorce were sometimes obtained from parliament for the wife's adultery.—In America, it was assumed in the colonial period that the granting of divorce was or might be legislative in its nature, and after the revolution the state legislatures assumed the right to pass special acts for the purpose. This, however, led to very serious abuses, and is now generally prohibited by the state constitutions, and jurisdiction for the purpose conferred upon the courts, with the causes specifically enumerated. The subject is so important that we have deemed it proper to give the causes recognized by the statutes of the several states as sufficient to warrant a divorce *a vinculo*, omitting in the specification, for the sake of brevity, those which under any system would render the marriage void or voidable, viz.: a previous marriage still in force, and a marriage under the age of consent, or within the prohibited degrees of relationship. Alabama: physical incapacity, adultery, desertion for two years, two years' imprisonment on a sentence of seven years or more, sodomy, pregnancy at marriage without the husband's knowledge, violence of the husband to the wife endangering her life, or reasonable fear there-

of. Arkansas: impotence, desertion for a year, conviction of felony or other infamous crime, habitual drunkenness for a year, such cruel and barbarous treatment as endangers life, or such indignities to the person as render the condition intolerable, adultery. California: adultery, extreme cruelty, consent obtained by force or fraud, wilful desertion, wilful neglect of the husband to provide for the wife for two years, habitual intemperance, conviction of felony, marriage of the female under 14 without consent of parents or guardian. Connecticut: adultery, fraudulent contract, impotence, wilful desertion for three years with total neglect of duty, seven years' absence not heard from, habitual intemperance, intolerable cruelty, sentence to imprisonment for life, bestiality, or any other infamous crime involving a violation of conjugal duty, and punishable by imprisonment in state prison, or any such misconduct as permanently destroys happiness and defeats the purposes of marriage. Delaware: adultery of the wife or impotence of either party, adultery of the husband being only cause for divorce from bed and board, with cruelty and desertion. Florida: impotence, adultery, extreme cruelty, habitual indulgence in violent and ungovernable temper, habitual intemperance, desertion for a year. Georgia: mental incapacity, impotence, force, duress, or fraud in obtaining the marriage, pregnancy at the time of marriage without the husband's knowledge, adultery, desertion for three years, sentence to the penitentiary for two years or more for an offence involving moral turpitude, habitual intoxication, cruelty. Illinois: impotence, adultery, desertion for two years, extreme and repeated cruelty, habitual drunkenness for two years, conviction of felony, or other infamous crime; and in addition to these causes the court may decree a divorce on other grounds if satisfied of the expediency of so doing. Indiana: adultery, impotence, abandonment for a year, cruel and inhuman treatment, habitual drunkenness, failure of the husband to provide, conviction of an infamous crime after marriage, and for such other causes as the court in its discretion may deem sufficient. Iowa: impotence, adultery, wilful desertion for two years, conviction of felony, habitual drunkenness, treatment that endangers life. Kansas: desertion for a year, adultery, impotence, pregnancy at the time of marriage by another than the husband, extreme cruelty, fraudulent contract, habitual drunkenness, gross neglect of duty, conviction of felony. Kentucky: impotence, living apart without cohabitation for five years, abandonment and living in adultery for six months, desertion for a year, conviction of felony, force, duress, or fraud in obtaining marriage, contracting a loathsome disease, uniting with any religious society which requires renunciation of the marriage contract or forbids cohabitation, confirmed drunkenness of the husband with im-providence continued for a year, habitual mis-

behavior of the husband continued in a cruel and inhuman manner not less than six months, cruel beating or injury of the wife or attempts at the same, pregnancy at the time of marriage without the husband's knowledge, adultery of the wife or such lewd and lascivious behavior on her part as proves her to be unchaste, confirmed mental unsoundness of not less than three years' continuance resulting from intemperance or hereditary taint and concealed at the time of marriage. Louisiana: adultery, habitual intemperance, cruelty, sentence to an ignominious punishment, desertion for five years, fleeing from justice when charged with an infamous offence. Maine: insanity or idiocy, sentence to imprisonment for life; and a divorce may be decreed when the judge deems it reasonable and proper, conducive to domestic harmony, and consistent with the peace and morality of society. Maryland: impotence, adultery, three years' desertion, unchastity of the woman before marriage unknown to the husband. Massachusetts: adultery, impotence, insanity or idiocy at marriage, uniting with a religious sect that professes to believe the relation of husband and wife void or unlawful and refusing cohabitation for three years, sentence to confinement for five years or more, desertion for five consecutive years. Michigan: adultery, impotence, sentence to imprisonment for three years or more, desertion for two years, habitual drunkenness, extreme cruelty, gross, wanton, and cruel neglect or refusal by the husband to provide for the wife. Minnesota: adultery, impotence, cruel and inhuman treatment, sentence to imprisonment in the state prison, wilful desertion for three years, habitual drunkenness for a year, cruelty. Mississippi: impotence, adultery, sentence to the penitentiary, desertion for two years, habitual drunkenness, habitual cruel and inhuman treatment, pregnancy unknown to the husband at the time of marriage, insanity or idiocy of one party at the time of marriage unknown to the other. Missouri: impotence, desertion for a year, adultery, conviction of felony or infamous crime, habitual drunkenness for a year, cruelty or indignities that render life intolerable, the husband becoming a vagrant, pregnancy by another than the husband without his knowledge at the time of the marriage. Nebraska: adultery, impotence, sentence to imprisonment for three years or more, desertion for two years, habitual drunkenness, extreme cruelty, consent obtained by force or fraud. Nevada: impotence, adultery, desertion for two years, conviction of felony or infamous crime, habitual gross drunkenness incapacitating the party from contributing to support of family, extreme cruelty, neglect of husband for two years to provide necessities. New Hampshire: impotence, adultery, extreme cruelty, actual imprisonment on conviction of crime for more than a year, treatment that seriously injures health or endan-

gers reason, three years' absence not heard from, habitual drunkenness for three years, joining a religious society which professes to believe the relation of marriage unlawful and refusing cohabitation for six months, abandonment for three years with refusal of cohabitation, refusal of the husband to provide for the wife for three years. New Jersey: adultery, desertion for three years. New York: adultery of either party (the sole cause occurring after marriage), impotence, idiocy, or lunacy at the time of marriage, consent obtained by force or fraud. North Carolina: impotence, abandonment, and living in adultery, "or any other just cause for a divorce." Ohio: three years' desertion, adultery, impotence, extreme cruelty, fraudulent contract, gross neglect of duty, habitual drunkenness for three years, imprisonment under criminal sentence. Oregon: impotence, adultery, fraudulent contract, sentence for felony, habitual drunkenness for two years, desertion for three years, cruel and inhuman treatment or indignities rendering life burdensome. Pennsylvania: impotence, adultery, desertion for two years, cruel treatment or indignities that render the condition intolerable and life burdensome, fraud, force, or coercion in procuring the marriage, sentence to two years' imprisonment for felony, becoming a lunatic or *non compos mentis*. Rhode Island: impotence, adultery, extreme cruelty, desertion for five years, or less in the discretion of the court, continued drunkenness, neglect or refusal of the husband to provide necessities, gross misbehavior and wickedness in either party repugnant to or in violation of the marriage contract. South Carolina: adultery, desertion for two years; and the deserting party may have divorce if the desertion is justified by cruel treatment, or by neglect of the husband to provide maintenance. Tennessee: impotence, adultery, desertion for two years, conviction of an infamous crime or of felony, malicious attempt upon the life of the spouse, pregnancy by another person at the time of the marriage without the husband's knowledge, cruelty, indignities by the husband to the wife forcing her to withdraw from him, abandonment of the wife or turning her out of doors and refusal to provide for her. Texas: impotence, adultery of the wife, desertion, adultery of the husband and abandonment of the wife for three years, cruelty. Vermont: idiocy or lunacy at marriage, adultery, sentence to imprisonment, for three years or more with actual confinement, intolerable severity, desertion for three years, absence for seven years without being heard from, neglect of the husband to provide maintenance. Virginia: adultery, impotence, sentence to the penitentiary, fleeing from justice for a felony and remaining absent for two years, desertion for five years, pregnancy at the time of the marriage by some person other than the husband without his knowledge, prostitution by the wife before marriage without the husband's knowledge, convic-

tion of an infamous offence before marriage without the other's knowledge. West Virginia: adultery, impotence, sentence to confinement in the penitentiary, desertion for three years, pregnancy at the time of the marriage by some person other than the husband without his knowledge, prostitution by the woman before marriage without the husband's knowledge, notorious licentiousness on the part of the husband before marriage without the wife's knowledge, conviction of an infamous offence before marriage without the other party's knowledge. Wisconsin: adultery, impotence, sentence to imprisonment for three years or more, desertion for a year, cruel treatment, habitual drunkenness for a year, voluntary separation for five years, neglect of the husband to provide a maintenance, or such conduct toward the wife as renders it unsafe and improper for her to live with him.—The subject of divorce has been extremely troublesome in the United States, owing to the diversity of laws, and the facility with which parties might pass from one state to another and obtain divorces without the knowledge of other parties concerned. Some very nice questions have arisen and been passed upon; and though the decisions are not wholly harmonious, the following may be stated as the general conclusions: 1. A *bona fide* residence of either party in any state will authorize such party to institute a proceeding for divorce in its courts for any cause permitted by its laws, whether arising there or elsewhere. 2. An attempt by one not a resident to institute such proceedings is a fraud upon the law and upon the other party, if such other party is ignorant of it; and the courts get no jurisdiction of such proceedings, and their decree, if one is made, is inoperative, and may be treated elsewhere as void. 3. If a *bona fide* resident institutes proceedings, but service cannot be made upon the other party by reason of absence from the state, it is competent to provide by law for service by publication, and such publication will be sufficient for the purposes of a dissolution of the marriage, but not sufficient for other purposes; as, for instance, the passing of a decree for alimony, or of an order for the custody of children. Before a party can be bound in such matters, he must have personal notice. 4. A divorce once granted with competent jurisdiction in one state is valid in any other state or country, and it leaves both parties at liberty to marry again, unless the statute where the divorce is granted otherwise provides; and even then it is presumed such statute could have no force beyond the limits of the state. It was formerly held in England that a marriage contracted in that country could not be dissolved elsewhere, and this led to serious contentions; but the contrary is now settled by the house of lords (9 Blyth's Reports, 79).

**DIX, Dorothea Lynde**, an American philanthropist and author, born in Worcester, Mass.

Left an orphan at an early age, she established in Boston a school for girls. She soon became interested in the condition of the unfortunate and criminal classes, and for many years was in the habit of visiting public institutions and ministering to the necessities of their inmates. In 1834 she went to Europe to investigate the methods of treatment for prisoners, paupers, and the insane. Returning in 1837, she visited all the states, and her exertions contributed greatly to the establishment of state asylums for lunatics in several of them. In 1848, and again in 1850, she petitioned congress for an appropriation of public lands to endow hospitals for the indigent insane. In 1854 a bill was passed granting 10,000,000 acres for this purpose; but it was vetoed by President Pierce. During the civil war she was superintendent of hospital nurses, having the entire control of their appointment and assignment to duty. After its close she resumed her labors for the insane. She has published several books, chiefly before entering upon her special work, including "Garland of Flora," "Private Hours," "Alice and Ruth," "Conversations about Common Things," and "Prisons and Prison Discipline." She has also written tracts for prisoners, and reports on philanthropic subjects.

**DIX, John Adams**, an American soldier and politician, born in Boscawen, N. H., July 24, 1798. During the war of 1812-15 he served on the frontier with the rank of ensign and as adjutant of a battalion. He established himself about the year 1828 as a lawyer at Cooperstown, N. Y., and became identified with the democratic party. In 1830 he was appointed adjutant general, and in 1833 secretary of state and superintendent of common schools. In 1842 he was elected to the assembly; and in 1845 he was chosen to fill a vacancy in the United States senate, caused by the election of Silas Wright as governor. On the question of slavery he was the exponent of the views of the free-soil section of the democratic party in New York, whose candidate for governor he was in 1848, but was defeated. In 1853 he was made assistant treasurer of the United States in the city of New York, but soon resigned. On Dec. 10, 1860, Howell Cobb resigned his post as secretary of the treasury, and Mr. Dix was appointed in his place. New Orleans was at the time in virtual possession of the secessionists; two revenue cutters were there, and the new secretary ordered them to New York. The captain of one of them, after consulting with the collector at New Orleans, refused to obey. Secretary Dix thereupon telegraphed to the lieutenant to arrest the captain, and to treat him as a mutineer in case he offered any resistance, closing his despatch with the words, "If any one attempts to haul down the American flag, shoot him on the spot." When the civil war broke out, Mr. Dix was appointed major general of the New York militia, and on May 16,

1861, major general of United States volunteers. He was placed in command of the department of Maryland, and in 1862 was transferred to Fort Monroe, having the command of the seventh army corps. In 1863 he was stationed at New York, where he was military commander during the riots which ensued upon the president's order for the draft. During 1864-'5 he commanded the department of the east. In September, 1866, he was appointed minister to France, which place he resigned in 1868, and returned to New York. In 1872 he was nominated by the republican party as governor of New York, and was elected. He is the author of "Resources of the City of New York" (1827); "Decisions of the Superintendent of Common Schools of New York, and Laws relating to Common Schools" (1837); "A Winter in Madeira" (1851); "A Summer in Spain and Florence" (1855); and two volumes of "Speeches."

**DIX, Morgan**, an American clergyman, son of the preceding, born in New York, Nov. 1, 1827. His early education and training were received in Albany, where he resided till 1842. He graduated at Columbia college in 1848, and from 1849 to 1852 studied theology in the general theological seminary of the Episcopal church. He was ordained deacon in 1852, and priest the next year. In September, 1855, he became an assistant minister of Trinity church, New York; he was chosen assistant rector of that parish in 1859, and on Dr. Berrian's death became rector, Nov. 10, 1862. He is a trustee of Columbia college, and holds a prominent place in the management of affairs in the Episcopal church in New York. He has published "A Commentary on the Epistle to the Romans," "An Exposition of the Epistles to the Galatians and Colossians," "Lectures on the Pantheistic Idea of an Impersonal-Substance Deity," "Essay on Christian Art," "Lectures on the two Estates, that of the Wedded in the Lord and that of the Single for the Kingdom of Heaven's Sake," several manuals of devotion, and occasional sermons.

**DIXON**, a N. E. county of Nebraska, separated from Dakota on the N. E. by the Missouri river, and watered by several streams; area, 700 sq. m.; pop. in 1870, 1,345. The surface is level. The soil rests upon limestone rock, and is fertile. The chief productions in 1870 were 27,923 bushels of wheat, 19,725 of Indian corn, 11,135 of potatoes, and 4,574 tons of hay. The total value of live stock was \$96,511. Capital, Ponea.

**DIXON, George**, an English navigator, born in 1755, died about 1800. He sailed in Cook's third expedition. On his return he was made captain in the navy, and in 1785 in concert with Capt. Portlock sailed on a new expedition, with two vessels, under the auspices of the Nootka sound company. In the course of their joint explorations they discovered a number of harbors, ports, bays, and small islands

on the coast of North America, and arrived at Hawaii, Sept. 28, 1786, whence Dixon proceeded to China, and in 1788 returned to England. He is the author of a description of his own expedition, under the title of "A Voyage round the World, but more particularly to the N. W. Coast of America" (1789); "Voyage of Meares" (1790-'91); and "The Navigator's Assistant" (1790).

**DIXON, James**, an English clergyman, born in Leicestershire in 1788, died at Bradford, Yorkshire, Dec. 28, 1871. In 1812 he entered the Wesleyan conference, and continued in the itinerant ministry till 1824, when he was sent as a missionary to Gibraltar. In 1825 he labored at Wakefield; in 1828 he preached in London, where he remained till 1833. After a term of pastoral service in Liverpool, he was appointed successively superintendent of the Sheffield and Manchester circuits. In 1841 he was chosen president of the British conference, and in 1848 he was elected by the Wesleyan conference a delegate to the general conference of the United States. He published "Methodism in its Origin, Economy, and Present Position;" "Memoir of the Rev. William E. Miller;" "Notes on America;" "The Present Position and Aspects of Popery, and the Duty of Exposing the Errors of Papal Rome;" and "Letters on the Duties of Protestants with regard to Popery."

**DIXON, William Hepworth**, an English author, born in Yorkshire, June 30, 1821. He entered a mercantile house in Manchester when 14 years of age, but early contributed some fugitive poems to several periodicals, wrote a tragedy which was printed privately, and became at length literary editor, of a paper at Cheltenham. In 1846 he removed to London, and entered as a law student at the Inner Temple. In 1849 he published a memoir of John Howard, and followed this by various publications, becoming well known as an author. He was a deputy commissioner of the world's fair of 1851. The next year he made a tour of the continent, and in 1853 became chief editor of the "Athenæum," which post he held till 1869. In 1864 he travelled in the East, and on his return assisted in founding the Palestine exploration fund. In 1866 he travelled in the United States, and visited the Mormons in Salt Lake City. Subsequently he made a journey through Russia. In 1869 he was appointed a magistrate for Middlesex, and in 1870 was elected a member of the London school board. His more important works are: "John Howard," which reached three editions in the first year, and many later editions in England and the United States; "London Prisons" (1850), which first appeared in the "Daily News;" "William Penn" (1851), a reply to Macaulay; "Robert Blake" (1852); "Personal History of Lord Bacon" (1861), first published in the "Athenæum," and afterward in book form in London, Boston, and Leipsic; "Lives of the Archbishops of York" (1863); "The Holy Land" (1865);



"New America" (1867), of which eight editions appeared in England, three in America, and several in France, Germany, Holland, and Russia; "Spiritual Wives" (1868), from his observations among the Mormons; "Free Russia" (1870); "Her Majesty's Tower" (4 vols., 1869-'71); "The Switzers" (1872); and "History of Two Queens: I. Catharine of Aragon; II. Anne Boleyn" (2 vols., 1873). The *Revue positive* of Paris published from him in 1869 a contribution entitled *Les sectes religieuses en Amérique*.

**DIXWELL, John**, one of the regicide judges of Charles I., born in 1608, died at New Haven, Conn., March 18, 1689. After the reaction in England which placed Charles II. upon the throne, and caused himself and his associates to be condemned to death, he escaped to America, took the name of John Davids, and lived undiscovered in New Haven, where he was married and left children. In 1664 he visited two of his fellow regicides, Whalley and Goffe, who had found a refuge at Hadley, Mass. His favorite study in exile was the "History of the World," which Raleigh had written in prison, and he cherished a constant faith that the spirit of liberty in England would produce a new revolution.

**DMITROV**, a town of Russia, in the government and 40 m. N. of the city of Moscow; pop. in 1867, 8,042. It has a college, a convent, and several churches, and manufactories of cotton, woollen, linen, and silk goods, and leather. An annual fair, lasting a week, is held here. The town covers considerable ground, much of it occupied by gardens, but the houses generally are poor.

**DNIEPER** (Russ. and Pol. *Dniępr*; anc. *Borysthenes*, also *Danapris*), next to the Volga the largest river of Russia in Europe. It rises on the S. slope of the Volkonsky plateau, near Dnieprovo in the government of Smolensk, flows S. between woody marshes as far as Dorogobush, thence mainly W. between more elevated banks past Smolensk to Orsha, there turns S., passes through the valleys and plains of the government of Mohilev down to Kiev, then turns S. E. through the steppes of the Ukraine, passes by Kremenchug and Yekaterinoslav, flows S. as far as Alexandrovsk, then S. W. to its mouth below Kherson, emptying into the Black sea between the fortresses of Kinburn and Otelakov. Its whole course is about 1,200 m. Its chief tributaries are, on the west, the Beresina, the Pripet, which discharges into it the waters of the Lithuanian marshes, and the Inguletz; on the east, the Desna, Sozh, and Vorskla. The Dnieper was formerly hardly navigable, owing to natural obstructions in its lower course and at the mouth. Some of these have been removed by the Russian government, but its commercial importance is still lessened by its frequent shallowness. About lat. 48° 20' it commences a course of more than 40 m. over a rugged bed of granite, forming below Yekaterinoslav a number

of cataracts and rapids, and separates into a great number of courses, embracing many woody islands. Reuniting, it becomes navigable in its lower course for flat-bottomed vessels, among which steamboats have been employed since 1838 in carrying the produce of the interior, timber, corn, linen, iron, and coal, to the Black sea. The Beresina, Oginski, and Royal canals, connecting tributaries of the Dnieper with the Dūna, Niemen, and Bug, form communications through these rivers between the Baltic and Black seas. The estuary or frith (Russ. *liman*) formed by the mouths of the Dnieper and by that of the Bog is very shallow, and emits noxious exhalations in summer. The Dnieper abounds in sturgeon, carp, pike, and shad. In its course it passes through the most fertile provinces of Russia, and through different climates. At Smolensk it is ice-bound from November to April, and at Kiev from January to March. The most remarkable bridges are in these two cities. At the latter is a magnificent suspension bridge half a mile long, completed in 1852. On the Kiev side is a drawbridge, with an opening 50 ft. wide. The ancients regarded the Borysthenes as the largest river of the world next to the Nile, and entertained an exaggerated opinion of the fertility of the surrounding country. They knew only its lower course. Near its mouth was Olbia, or Olbiopolis, a colony of Miletus, which carried on trade with the nomadic tribes of the interior.

**DNIESTER** (Pol. and Russ. *Dnięstr*; anc. *Tyras* and *Danaster*), a river of eastern Europe, which has its source in a small lake on the N. E. slope of the Carpathian mountains, S. W. of Lemberg in Galicia, and flows mostly S. E. about 600 m. As far as Old Sambor it passes through a broad valley, which afterward expands into an extensive plain on the east, while spurs of the Carpathians here and there skirt the W. banks. At Khotin, where it enters Russian territory, it flows through an open flat country separating the province of Bessarabia from Podolia and Kherson on the east, and then discharges into the Black sea by a shallow liman 19 m. long and 5 broad, between Akerman and Ovidiopol. It receives a number of tributaries in Galicia, the principal of which are the Stry, Strypa, and Sered, and only a few insignificant ones during its course through Russia. Its current is rapid, and navigation is interrupted between Yampol and Bender by two falls and several whirlpools, and its mouth is encumbered with flats and sand banks. Wood, grain, and other products are carried down it toward Odessa.

**DOAB** (Sanskrit, two waters), a name given in Hindostan to any tract included between two rivers. It is especially applied to that lying between the Ganges and the Jumna, and when applied to other similar districts is joined with some distinctive appellation, as the Julunder Doab, between the Beas and the Sutlej, and the Rukna Doab, between the Ravee

and the Chenaub. The Doab is a large tract reaching from Allahabad in the south to Saharunpoor in the north, and forming the finest and most fertile part of the province of Agra. It contains many thriving towns, and the whole territory has been brought into a highly productive state by a system of irrigation. It has a British military station and a strong fort.

**DOANE, George Washington**, an American bishop, born at Trenton, N. J., May 27, 1799, died at Burlington, N. J., April 27, 1859. He graduated at Union college in 1818, was admitted to holy orders in 1821, officiated for three years in Trinity church, New York, and in 1824 was appointed the first professor in Washington (now Trinity) college, Hartford. In 1828 he became assistant minister, and afterward rector of Trinity church, Boston, where he remained till 1832, when he was elected bishop of New Jersey, whereupon he removed to Burlington, and became rector of St. Mary's church in that city. Here he devoted his energies to the establishment of a comprehensive system of Christian education for females, and opened in 1837 St. Mary's hall, a boarding school for girls, beautifully situated on the shore of the Delaware. In consequence of the great success of this enterprise, he founded Burlington college in 1846. Under his episcopate the church in New Jersey experienced an unexampled increase in the number of its communicants, from 801 in 1832 to 4,500 in 1858, while the clergy increased from 14 to 90 in the same period, and the number of parishes from 31 to 79. In 1824 he published a volume of poems entitled "Songs by the Way." A volume of his sermons was issued in London in 1842. His life has been written by his son, W. C. Doane, who has also edited his "Poetical Works, Sermons, and Miscellaneous Writings" (4 vols., 1860).

**DOBBERAN, or Doberan**, a watering place of Germany, in the grand duchy of Mecklenburg-Schwerin, on the Baltic, 9 m. W. N. W. of Rostock; pop. about 4,000. It contains two palaces, with fine pleasure grounds, a theatre and other places of recreation, and one of the most remarkable Gothic churches of northern Germany. The bathing establishment is three miles from the town, at the Heilige Dam, a huge embankment said to have been thrown up by the sea in a single night.

**DOBELL, Sydney**, an English poet, born at Peckham Rye, near London, April 5, 1824. In 1835 his father, a wine merchant in London, removed his business to Cheltenham. At the age of 12 he entered the counting room of his father, with whom he remained as a clerk for 12 years, devoting his leisure hours to literary pursuits. In 1848 he removed to Leckhampton, Gloucestershire, where he wrote his dramatic poem, "The Roman," published in 1850 under the *nom de plume* of "Sydney Yendys." In 1854 he published "Balder." These poems found many admirers, who hailed the author as the originator of a new era in English poetry.

They were, however, severely criticised, and were travestied by Aytoun in his "Fermilian." In 1855 Mr. Dobell united with Alexander Smith in a volume of "Sonnets on the War," and in 1856 in a series of poems under the title of "England in Time of War." In 1865 he wrote a pamphlet on "Parliamentary Reform," advocating a graduated suffrage and the system of a plurality of votes. In 1871 he produced "England's Day," a volume of lyrics against what he regarded as the hostile attitude of Germany, Russia, and the United States.

**DÖBELN**, a town of Saxony, on the Mulde and on the railway from Chemnitz to Riesa, 36 m. S. E. of Leipzig; pop. in 1871, 10,078. It has a high school, two churches, a hospital, and manufactories of cloth, leather, brassware, and hats. It is also the centre of a considerable trade in cattle and grain, and has three annual fairs. The town is well built, on an island formed by the Mulde and Mühlgraben.

**DÖBEREINER, Johann Wolfgang**, a German chemist, born near Hof, Dec. 15, 1780, died in Jena, March 24, 1849. He was professor of pharmacy and chemistry in the university of Jena from 1810 till his death, and had intimate relations with Goethe and the grand duke Charles Augustus of Weimar; their correspondence with him was published in 1856. He made several chemical discoveries, among them the combustibility of platinum, the apparatus for suddenly producing light by directing a jet of hydrogen upon a piece of platinum sponge being known as Döbereiner's lamp. His principal works are: *Zur pneumatischen Chemie* (5 vols., Jena, 1821-'25), *Zur Gährungschemie* (1822), and *Zur Chemie des Platins* (Stuttgart, 1836). With his son FRANZ, the author of *Kameralechemie* (Dessau, 1851), he published *Deutsches Apothekerbuch* (3 vols., Stuttgart, 1840-'44).

**DÖBRENTEL, Gábor**, a Hungarian author, born at Nagy-Szöllös in 1786, died in 1851. He studied at Wittenberg and Leipzig, and in 1810 established the "Transylvanian Museum," a periodical which exercised considerable influence upon the Hungarian literature of the period. In 1820 he removed to Pesth, and in 1827 was one of 22 savants invited to assemble at Buda to devise a plan and constitution for the Hungarian academy. Of the great work of his life, the "Ancient Monuments of the Hungarian Language," four volumes were published by him and a fifth was left nearly completed. His poems, which consist of odes, epigrams, and elegies, have been translated into several languages. He translated some of Shakespeare's plays, Molière's *Avare*, and several tragedies of Schiller into Hungarian.

**DOBRIZHOFFER, Martin**, a Jesuit missionary, born at Gratz, Styria, in 1717, died in Vienna, July 17, 1791. He was sent to South America in 1749, and passed 18 years among the Indians inhabiting the W. bank of the Paraguay river and the interior of Paraguay. When the Jesuits were expelled from the Spanish colonies he went

to Vienna, where he enjoyed the favor of Maria Theresa. His principal work is a history in Latin of the Abipones (Vienna, 1784), of which a German translation appeared in Pesth in the same year, and an English translation by Miss Sara Coleridge in London in 1822.

**DOBRODJA.** See DOBRUDJA.

**DOBROVSKY, Jozef,** a Slavic scholar, born near Raab, Hungary, Aug. 17, 1753, died in Brünn, Moravia, Jan. 6, 1829. He early applied himself to the study of the German language, and acquired afterward still greater knowledge of the Bohemian. He studied at the university of Prague, became a Jesuit at Brünn in October, 1772, and after the dissolution of that order in July, 1773, devoted himself to literature. From 1780 to 1787 he conducted a journal devoted to the literature of Bohemia and Moravia. His subsequent works on the Slavic languages and history gained him the reputation of having laid the foundation of Slavic philology. The most celebrated of them are the *Geschichte der böhmischen Sprache* (1792), *Entwurf zu einem allgemeinen Etymologikon der slavischen Sprachen* (1813), and *Institutiones Linguae Slavicae Dialecti veteris* (Vienna, 1822). In 1792 and 1794 he visited Sweden, Russia, and western Europe, to collect documents bearing upon Slavic history. On his return he was for several years afflicted with insanity, brought about by the intensity of his labors, but recovered his health in 1803. An account of his life and writings was published by Palacky at Prague in 1833.

**DOBRUDJA,** the N. E. portion of Bulgaria, Turkey, on the right side of the Danube, extending from Silistria and Varna to the mouth of that river, offering the most accessible military route from the north to Constantinople. The Russians commenced here their operations against Turkey in 1828; and again in 1854, having crossed the Danube at Braila and Galatz, they gained an important advantage by securing Matchin, one of the principal towns of the district. It was restored to Turkey by the treaty of peace of 1856. The population consists of 16,000 to 20,000 families of Bulgarians, Tartars, Cossacks, Turkomans, Armenians, Greeks, and Jews, who support themselves chiefly by the raising of cattle and bees, by the manufacture of salt, and by fisheries. The country is flat, containing several large swamps, and lakes on the coast. Some parts are very fertile, and produce good crops of grain; others are covered with grasses. The herbage dries up early in summer, and the flocks of sheep and herds of buffaloes go to the borders of the Danube for pasture. The wall of Trajan crosses the Dobrudja at about lat. 44° 10' N. The most important towns in this district are Tultcha, Kustendji, Baba Dagh, and Hirsova. A railway connects Tchernavoda on the Danube with Kustendji on the Black sea.

**DOBSON, Thomas,** a bookseller and author of Philadelphia, died March 8, 1823. He republished the "Encyclopædia Britannica" (21

vols. 4to, including the supplement, 1798-1803), and wrote "Letters on the Character of the Deity and the Moral State of Man" (2 vols. 12mo, 1807).

**DOBSON, William,** an English painter, born in London in 1610, died in 1646. He served an apprenticeship with a portrait painter and picture dealer, and availed himself of the opportunity thus offered him to copy some of the works of Titian and Vandyke. One of his pictures fell by chance under the eye of Vandyke, who was so much struck by its merit that he presented the painter to Charles I., who sat to Dobson for his picture, and upon the death of Vandyke conferred upon him the title of his chief painter. Several of his portraits are in the cabinet of the duke of Northumberland. One of his best historical pictures is the "Decollation of St. John," at Wilton.

**DOCE, Rio,** a river of Brazil, rising at the base of Mt. Itacolumi, S. E. of the city of Ouro Preto, province of Minas Geraes. It flows N. 180 m., then bends first E., afterward S. E., then N. E., flowing through the province of Espirito Santo, finally curves abruptly to the S. E., and falls into the Atlantic near the town of Regencia. The mouth is wide and shallow, and traversed by a bar on which the waves break with great violence, so that the entrance to the river is always difficult, and often for weeks together impossible. As far up as Porto de Souza the river is navigable all the year round by small steamers; but at that point begin the rapids which render navigation impossible save for canoes, and even these must in some parts be unloaded before hauling them over the rapids. The banks of the Doce are for the most part high and steep, bordered by mountains with a rich clothing of forest, in which abound trees furnishing many species of valuable wood. During the rainy season the Doce sometimes rises 20 feet above its ordinary level.

**DOCETÆ,** in the primitive church, the partisans of those doctrines which admitted the appearance but denied the reality of the human form and nature of Jesus Christ. Those who looked upon matter as essentially evil were offended at the idea of a revelation of Deity through sensible objects, and declared that everything corporeal in Christ was only in appearance, and for the manifestation of the spirit, and that his life was merely a continued theophany. It was probably against Docetic doctrines, which had appeared even in the time of the apostles, that some passages in the gospels and epistles of St. John were directed. Docetism, of which there were various forms, was itself one of the earlier forms of Gnosticism, and its teachers, as Valentinus, Cassianus, and Bardesanes, who flourished in the latter half of the 2d century, are reckoned among the Gnostics. Its purpose was to reconcile the narrative of the gospels with the respect due to the Deity, in maintaining that the sufferings and death of Christ were only apparent, in opposition to the realistic doctrine of the Ebionites.

**DOCK** (Gr. *δοκίη*, Dutch *dok*, Ger. *Dock*, a receptacle), an artificial enclosure in connection with a harbor or river, used for the reception of vessels, and provided with gates for keeping in or shutting out the tide. There are two kinds of docks in general, wet and dry docks, the former so called because they retain their water for the purpose of keeping vessels afloat. In the United States wharves are popularly but erroneously called docks. Enclosed basins not closed by gates, in consequence of there being no necessity for it because of small tides, are called docks with better reason, as the Atlantic dock at Brooklyn, which will be described in this article, although according to the accepted definitions it should strictly be classed as a basin. The late English engineer Rankine calls a reservoir surrounded by quay walls, and having a single gate without a lock, a basin, restricting the term wet dock to a reservoir which is entered through a lock. Either kind of structure, however, is usually called a wet dock. A dry dock is one from which the water may be shut or pumped out so as to become dry, leaving a vessel in a position to be inspected or repaired. Floating docks and screw docks are varieties of dry docks by means of which vessels are raised out of the water by the buoyancy of pontoons or the application of screw power. Vessels are also drawn out upon inclined railways which are called slips; but these cannot properly be called docks, as they are not receptacles in the sense in which the word is understood.—**WET DOCKS** are important structures in harbors where there is considerable rise and fall of tide, serving not only to keep ships afloat, but to maintain a convenient level. They are of comparatively recent date. The Mediterranean, upon which most of the commerce of the world till within a few centuries was conducted, has so little rise and fall of tide, and the vessels used by the ancients were of so small a size, that the necessity of maintaining a level equal to that of high tide did not exist. Liverpool was the first city to embark to any extent in their construction, and for a long time her docks were unrivalled in size and magnificence. In the harbor of New York, at Philadelphia, and at Baltimore and other ports in Chesapeake bay, the rise and fall of the tides are so inconsiderable as to render such docks as those upon the Mersey and the Thames not only unnecessary but inconvenient. The Atlantic dock, therefore, has no gates. The maintaining of a level of 4 or 5 ft. above low water would doubtless often be an advantage, but the expense necessary to secure it would be greatly disproportionate. At Liverpool, however, where the difference between high and low tide is about 15 ft., and at London, where it is 18 ft., the case is different. Liverpool owes all her great commercial prosperity to the number and extent of her docks, which cover an area of over 200 acres. Without them the Mersey would never have afforded much

more than an indifferent harbor for fishing and other small vessels. In the Clyde, where the tides are small, they have not been used, although the idea of providing them has been entertained. Wet docks are constructed with a wall of masonry, or of piling with concrete and tamped clay filling, and with a clay or concrete bottom. The enclosed area may vary from four or five acres, as at Leith, to 70 or more, as the Victoria dock at London. The higher the level of the water in the dock is kept above the low or mean tide of the harbor, the stronger and more impervious the walls require to be made. When the area is not too great the water is sometimes maintained at the highest tide level by pumps, mainly to avoid the necessity of admitting too much sedimentary matter with the entrance of the tide when the water in the harbor is very turbid. In planning a dock, among other things to be considered is the proportion of the surface of water to the length of the quay walls, which should be as small as is consistent with convenience in manœuvring the vessels. The docks of Great Britain are usually entered through locks having two gates similar to those on canals. The entrance locks to the docks of London vary in width from 40 to 80 ft., and in length from 100 to over 326, depending upon the class of vessels which it is intended to accommodate. The Victoria docks comprise a tidal basin of 16 acres at the entrance from the Thames, and a main dock of 74 acres. The earthy strata which occupied the site of the dock consisted of a top soil one foot deep, a layer of clay about 5½ ft. thick, then one of peat from 5 to 12 ft., and beneath this a bed of gravel, lying upon the London clay. The dock and basin were excavated to a depth of 26 ft. below high-water mark, and its bottom puddled with clay to a depth of 2 ft., leaving the finished surface 24 ft. below Trinity high-water mark. The entrance from the river into the basin is by a lock having two pairs of wrought-iron gates, revolving in hollow quoins, the walls of the lock being constructed of cast-iron piling, T-shaped in section, backed with hydraulic concrete. The gates are what are called cylindrical in form; that is, they are portions of a cylinder, with the convexity turned toward the basin. The lock chamber is 80 ft. wide at the bottom and 326½ ft. long, including the upper and lower gate platforms upon which the gates are supported while turning upon a circular roller path. On the site of the lock the surface of the London clay was 37 ft. below high-water mark, and to this depth the excavation was carried at this point, and the foundations of the gate platforms were laid. Between the platforms the bottom of the lock was filled with clay puddle to a level of 28 ft. below high-water mark. The upper gate platform is 25½ ft. below that mark, while the lower one is 28 ft., or at the same depth as the bottom of the lock; so that, the mean fall of tide being 18 ft., there will be 10 ft. depth of

water in the dock below the upper platform at low tide. The entrance from the tidal basin into the dock is by means of a single pair of gates, similar to those of the lock, placed between two dumb jetties or walls which separate the basin from the dock. (See fig. 1.) The basin and dock are 4,050 ft. in length and 1,050 ft. in width. There are six jetties—the two just mentioned, which are each 485 ft. long, and four others extending from the north wall into the dock a distance of 581 ft., including the pointed terminations. These with the sides of the dock and basin afford nearly three miles of quay room. The four interior jetties are each 140 ft. wide for 497 ft., and the surface of the quay varies from 6 to 9 ft. above high-water mark. The side walls are vertical and constructed of cast-iron piles 7 ft. apart from centre to centre, filled in between with brick set in Roman cement, the

brickwork being arched toward the back to give strength. Behind the piles and brickwork there is a wall of concrete which was carried up from below the clay bottom, and behind this a filling of clay. The piles are T-shaped in section, and are 35 ft. long and 1 ft. wide on the face, averaging  $1\frac{1}{2}$  in. in thickness, and weighing about  $1\frac{3}{4}$  ton each. They are driven to a depth of 28 ft. below high-water mark, and therefore 4 ft. below the bottom of the dock. The brickwork commences one foot above the bottom, and rests upon concrete 3 ft. thick. The wall is covered with a cast-iron plate bolted to the heads of the piles, and upon these lies a timber sill. The piles in the opposite jetty walls are connected by cross bars, 5 and 17 ft. below their heads. Upon each jetty there is a warehouse 500 ft. long and 80 ft. wide, leaving wharf room 30 ft. wide; and it is also supplied with nine hydraulic cranes, one

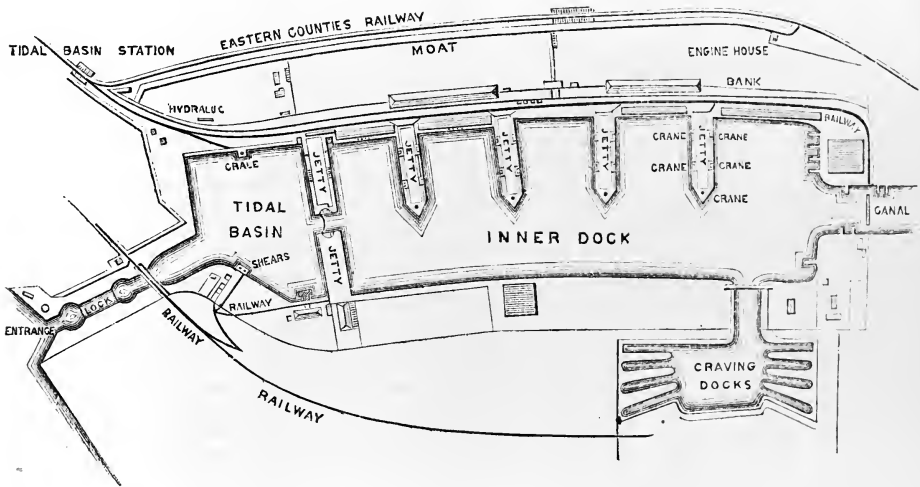

FIG. 1.—Plan of the Victoria Docks at London.

of five tons power at the pointed end, and eight others of two tons power each along the sides. Connected with the north side is a basin which opens into eight graving or dry docks. (For a more detailed description of this work, and also of the docks upon the Tyne, see Spon's "Dictionary of Engineering," London, 1871.) The West India docks, constructed in 1802 in a gorge in the Isle of Dogs, comprise an import dock of 30 acres, an export dock of 25 acres, communicating with the Thames at Blackwall, and a bonded timber dock of 19 acres. The gates are 45 ft. wide, admitting vessels of 1,200 tons. The whole space occupied by docks and warehouses is 295 acres. The East India docks, also at Blackwall, completed in 1806, belong to the same company as the former. They include an import basin of 18, an export basin of 9, and an entrance basin of  $2\frac{3}{4}$  acres. The gates are 48 ft. wide, and the depth of water 23 ft. The Commercial docks, situated on the

opposite side of the river, existed in 1660 under the name of the Howland great wet dock, and subsequently of the Greenland docks, having been prepared for the accommodation of the Greenland whaling vessels. In 1807 they were greatly enlarged and received their present name, and are now used chiefly to receive vessels laden with corn, iron, lumber, guano, and other bulky articles. They cover an area of 120 acres, 70 of which are water. The granaries will contain 140,000 quarters of corn. The other principal docks here are the London and the St. Katherine docks, the latter situated between the former and the tower. The warehouses in the St. Katherine docks are built upon the water's edge, without a quay; but this plan has since been disapproved on account of interference with the ships' rigging. The docks at Liverpool were authorized by an act of parliament in 1708. There are numerous other mercantile wet docks in Great Britain, a list of which, including entrance basins pro-

vided with locks, at the principal ports, is appended :

PORTS.	No.	Area in acres.
London.....	23	350
Liverpool.....	83	206
Birkenhead.....	4	142
Bristol.....	4	79
Hull, exclusive of timber pounds.....	7	46½
Great Grimsby.....	2	51
Hartlepool.....	1	20
West Hartlepool, exclusive of timber pounds.....	2	32
River Wear.....	3	41
River Tyne.....	4	107
Leith.....	3	15½
Dundee.....	4	34
Aberdeen.....	1	35

—The docks at Cherbourg were commenced by Napoleon I., and the first basin was opened in August, 1813. (See CHERBOURG; also for notices of other docks, see the articles on the places where they are situated.)—The Atlantic dock at Brooklyn, technically a tidal basin, was constructed by the Atlantic dock company, chartered by the state legislature in 1840. The work was commenced in 1841, and

The enclosure on the water side was made with cribwork piers consisting of timber filled with stone, sunk in trenches 30 ft. below high-water mark. The cribs were 25 ft. thick at the base, and were placed with their external sides 150 ft. apart, that being the width of the pier, the top of which is 10 ft. above low-water mark. The space between them was filled with sand and gravel from the excavations in the basin. Piles were driven into the filling to a sufficient depth and sawn off 5 ft. below the surface; and upon the heads of the piles the stone foundations of the warehouses were placed. The entrance is between the north and south piers, and is 200 ft. wide. The excavation over the whole 40 acres was made principally with dredging machines working by means of an endless chain, and was carried to an average depth of 20 ft. below low-water mark, or 25 ft. below high-water mark. In the basin, reaching from either end, are wooden piers of sufficient width for the unloading of ships, built of piles covered with timber and plank-ing. Upon the cribwork piers, one of 1,070 and the other of 1,000 feet in length, there are commodious stone warehouses, 100 ft. in depth and extending the length of the piers. Upon the opposite or inland side of the basin is the commercial wharf, 2,000 ft. in length, and upon this there are three blocks of warehouses, each 460 ft. long and 180 ft. deep, besides an iron yard of the same dimensions. There are several grain elevators situated upon different parts of the wharves. A plan of the dock is given in fig. 2; for a further description and a perspective view, see BROOKLYN.—**DRY DOCKS**, often called graving docks, because used for graving or cleaning the bottoms of ships, consist, as before stated, of those which are pumped dry and those which discharge the water by being raised. The former are usually built of masonry, but are sometimes constructed of piling, concrete, and clay puddling. Two of the latter kind were constructed at the Erie basin, near the Atlantic dock, which are 500 ft. in length by 90 in width at top and 480 by 50 ft. at bottom, and 30 ft. deep. The dry dock at the Brooklyn navy yard is the finest structure of the kind in the United States. It was commenced in August, 1841, and completed in August, 1851. The construction of the coffer dam and the excavation which initiated the work are described in the article DAM. The main chamber of the dock, fig. 3, *a*, is 286 ft. long and 30 ft. wide at the bottom, and 307 ft. long and 98 ft. wide at the top, this being the distance between the folding gates *g g* and the head of the dock *e*. Behind the folding gates is what is called the lock chamber, *c*, 52 ft. long, which length may be added to the dock when it is required, a caisson, *d*, forming the external gate being sufficient to exclude the water. The bottom is 26 ft. below mean high tide, and 30 ft. 8 in. below the coping. The foundation had to be constructed in quicksand, and consisted of piling driven to great depth, covered

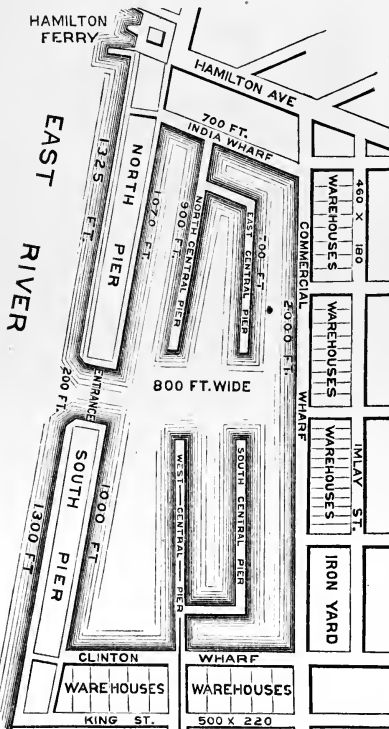

Fig. 2.—Plan of Atlantic Dock.

occupied several years. Over 200 acres of land were purchased at a point on the Long Island shore opposite Governor's island, and 60 acres of the low land and marsh were converted into a basin having 40 acres of water surface.

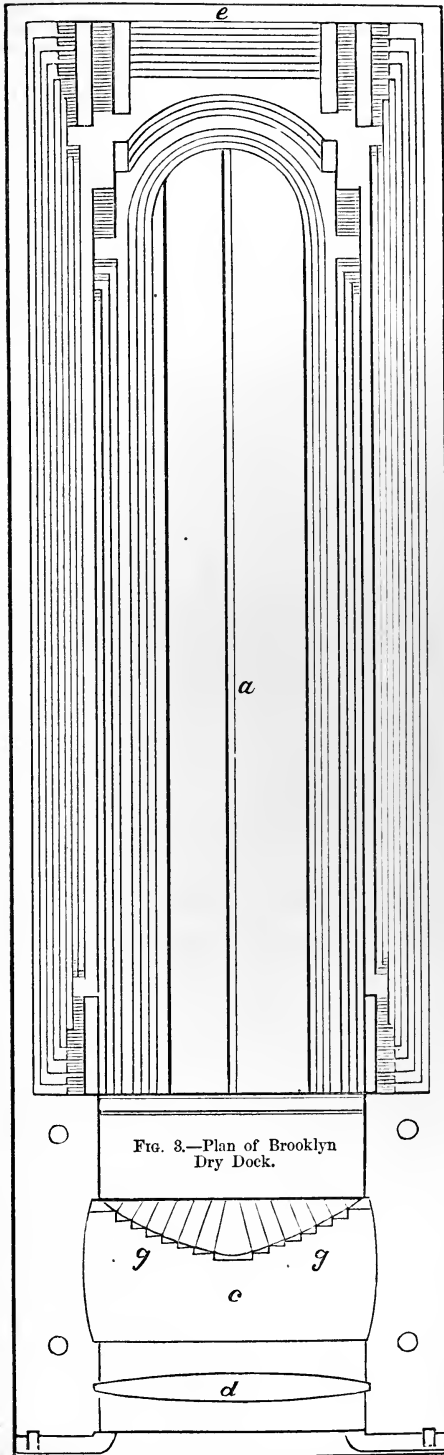

FIG. 3.—Plan of Brooklyn Dry Dock.

with 18 in. of hydraulic concrete, this covered with cross timbers of yellow pine 12 in. square, and this again with 3 ft. granite blocks laid in hydraulic cement. A cross section is represented in fig. 4. The walls, composed of heavy granite blocks laid in hydraulic cement, are carried up vertically from this foundation, and are 108 ft. from outside to outside, being 5 ft. thick at the coping and 39 ft. at the bottom or lower step, and varying in thickness

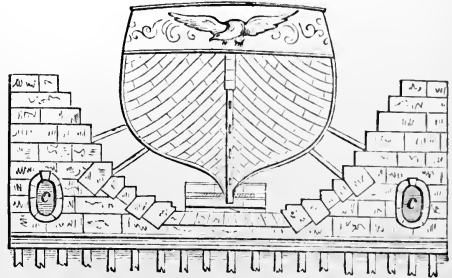

FIG. 4.—Transverse Section of Brooklyn Dry Dock.

between these two points in accordance with the curve, which is irregular and made to correspond with the general curve of the side of a ship. The distance between the quoins in which the folding gates revolve is 66 ft., and this is about the average width of the lock chamber, and also of the length of the deck of the caisson or outer gate, which has also a beam of 16 and a depth of 30 ft. Two culverts, *c, c*, one on either side of the entrance and below the surface at low tide, admit water and carry it in a descending course to the bottom of the dock a few feet in front of the inner gates. These culverts have a calibre of 4 ft. 9 in. vertical by 2 ft. 5 in. horizontal. At the points where they enter the dock commence the discharge culverts, which are carried on either side to a point beyond the head, where they unite and empty into a well under the engine house. From this well the water is pumped into a culvert which descends to the river and discharges at a point near the entrance of the dock. The pumping engine can empty the dock in 2h. 10m., its capacity when filled by the tide being about 600,000 cubic feet. When a ship is docked, the filling culverts are closed, as well as the passages from the dock chamber to the draining culverts leading to the pump well, and the water is pumped from the latter; the ship is then admitted and placed over the keel block in the centre of the dock; the caisson is next floated to its place, over the recess or groove, and filled with water until it sinks down to the bottom of the masonry fitted to receive its keel; after which the turning gates are closed by men standing on the bridge, and working the four hand wheels that move the machinery. The culvert gates in the dock chamber are next drawn and the water is allowed to flow into the draining culvert and well, by which means

the water is lowered several inches in the dock in a few minutes, thus hastening the shoring and producing an immediate pressure on the gates, so as to effectually prevent the admission of water and fix them steadily. A complete command of the level at the moment the gates are closed, or when a ship, especially a large one, is about to touch the blocks and requires the placing of shores, is important; and the above method gives a more perfect control of the operation for the first foot than could be obtained by the best regulated pumps and machinery for driving them.—There are also naval dry docks at the navy yards of Boston, Portsmouth, Norfolk, Pensacola, and San Francisco. The Boston dry dock, situated at Charlestown, is of granite, 256 ft. long and 86 ft. wide, with a depth at mean high tide of 25 ft. The length of the dock may be increased 53 ft., like the one at Brooklyn, by leaving open the turning gates and using the caisson alone. It was commenced in 1827 and finished in 1834. The dry dock at Norfolk, Va., built at the same time, is also of granite. Before its completion the ship of the line Delaware was docked in it in 1833, on the anniversary of the battle of Bunker Hill (June 17), being the first national ship ever docked in a United States dry dock. Its dimensions and construction are like those of the Boston dock.—There are 11 dry docks at the Portsmouth navy yard, England; among them two (double locks), each 644 ft. long, with gates 89 and 88 ft. in width and a depth of water at highest tides of 25 and 27 ft.; and another 426 ft. long, with gates 70 ft. wide, and a depth of 25 ft. 9 in. at high tide. At Devonport there are five dry docks, one 437 ft. long, with an entrance 73 ft. wide, and a depth of water at high tide of 31 ft. There are 18 dry docks at Liverpool, some of them over 500 ft. long, the Canada graving dock having an entrance width of 100 ft. and a maximum depth of water of 26 ft. At Birkenhead there are six dry docks, two of them 750 ft. long at the bottom, with gates 85 and 50 ft. wide, and a depth of 29 ft. 9 in. at high water. There are numerous other magnificent structures in other parts of the kingdom. The number of floating basins in the English government dockyards is 11, comprising a total area of 35 acres, and having a lineal quay space of 13,500 ft. The dry docks at Sebastopol, which were mainly destroyed after the capture of the city, Sept. 8, 1855, were situated considerably above the level of the Black sea, and the expense of pumping was entirely avoided; ships were raised into a general dock basin by a series of three locks, each of which had a rise of 10 ft. The water for supplying the basin, for filling the docks, and for working the locks, was brought by a canal 12 m. long, which taps a mountain stream. Vessels, after being elevated into the general basin, were floated into one of these dry docks, and the gates being closed, the water was let off into the sea through a subterranean culvert.—A floating

dry dock, called a balance dock, and which was patented by John S. Gilbert of New York, consists of a pontoon divided into compartments, which may be so filled with either air or water as to preserve a balance of position, and by its buoyancy to be capable of raising vessels. It may be built of timber and planking, or of wrought iron and planking. Those which are used in New York have the framework entirely of wood, and one of them has been in use for nearly 30 years. The pontoons may be from 8 to 12 ft. in depth, and 100 or more in breadth by 350 or more in length. They are strongly girded and trussed, and have a strong bulkhead running through the middle for the whole length, upon which the keel of the vessel is supported by keel blocks. At either side the dock rises into walled chambers, which may be also filled with water or air, and upon the deck of which are placed steam engines for the purpose of pumping the water from the interior. The ends of the dock are left open, so that when the vessel is raised the water readily flows from the dock. Fig. 5 represents the larger of two docks owned by the New York balance dock company. It is 325 ft. long, 100 ft. wide, and 30 ft. from deck of pontoons to

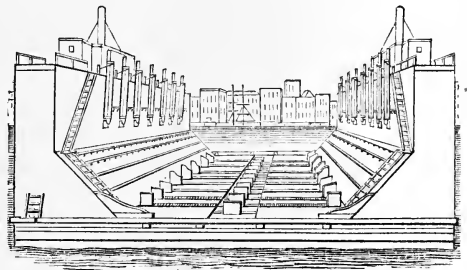

FIG. 5.—Balance Dock.

deck of side walls, or 40 ft. in all, the pontoons being 10 ft. deep. It has 8 gates on either side for admitting, and 8 others for discharging water, which is pumped out by steam engines, one upon either wall, of 40 horse power each. The pumps are 14 in number, 7 on either side, of 36 in. diameter and 35 in. stroke, capable of exhausting with sufficient rapidity to raise a vessel of 3,000 tons in an hour and a half. Its total lifting power is estimated at 8,000 tons. In docking a vessel on the balance dock, the pumps are first set in motion by the steam engines on the deck above, and the discharge opening being closed by a gate for that purpose, the water rises in the chamber above the pumps until it is full to the deck of the dock. It is next allowed to flow into the upper chamber of the dock until its weight, acting as ballast, sinks the dock to the required depth. When the ship is floated into the dock, this ballast is drawn off by means of valves, causing the dock to rise by its own specific gravity until it touches the bottom of the ship, after



which the vessel is lifted by pumping the water out of the side chambers and bottom tank; and as the dock rises, the water around the ship in the middle chamber ebbs out, so that

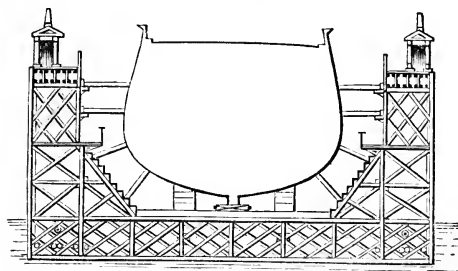

Fig. 6.—Transverse Section of Rennie's Floating Dock.

the quantity of water to be exhausted in raising a vessel is in proportion to her weight and not to her bulk.—Fig. 6 represents a cross section of an iron floating dock, built mainly upon the same principle as the New York floating dock, differing however in having air chambers in the upper part of the walls, by means of which the depth of sinking is controlled. It was constructed by Mr. G. B. Rennie for the port of Ferrol on the N. W. coast of Spain. It is 350 ft. long, 105 ft. wide, and 50 ft. high in extreme dimensions. The depth of the pontoon is  $12\frac{1}{2}$  ft., leaving a height of  $37\frac{1}{2}$  ft. from the deck of the pontoon to the deck of the side walls, so that if the keel blocks occupy 5 ft. and the deck remains  $4\frac{1}{2}$  ft. above water, there will be a clear depth of 28 ft. of water for the admission of ships. The total weight of the dock is about 5,000 tons, and the displacement by the pontoon is equal to 13,000 tons, leaving a lifting power of 8,000 tons. It is constructed of plate, angle, and T iron, riveted together in one structure. The pontoon is divided by a water-tight bulkhead running the whole length, each half being subdivided by 10 transverse bulkheads. The upper part of the side walls is composed of air-tight chambers having a capacity sufficient to prevent the dock from sinking below any desired level. The pontoon is strengthened by open lattice girders equal to it in depth, 34 of these being transverse, on either side. It is covered with three-inch teak plank, laid longitudinally, and upon this over every third transverse girder are transverse beams of teak 2 ft. square, for the support of the keel and bilge blocks. Keel blocks are also placed on the intermediate girders. Four large sluices, two on either side, communicate by pipes 18 in. in diameter with the several compartments, the pipes having cocks to regulate the quantity of water in each compartment. There are four pumps on either side, of 2 ft. 9 in. stroke and 26 in. diameter, worked by steam. Four capstans are placed at each end for moving and mooring.—The New York sectional floating dock was patented

by Phineas Burgess in 1838, and the first dock was begun by Burgess and Dodge in 1839. It consists of a number of floating pontoons, which form the dock by being placed side by side. At the end of each pontoon there is a framework of timber which supports machinery for pumping, being sufficiently high to remain out of water when the dock is submerged. This framework projects beyond the end of the pontoon, and its lower part contains what is called a balance tank, an air-tight chamber, which may be raised and lowered by means of a rack and pinion connected with the pumping machinery. These tanks have much the same use as the air chambers in the iron floating dock just described; by raising them the depth of the deck of the pontoons will be increased, and by lowering them the pontoons will be raised, independently of the amount of air or water the latter may contain. Fig. 7 represents the largest of these docks owned by the company. It consists of 10 sections, which when placed close together form a dock 350 ft. long and 110 ft. broad. These sections may be placed at some distance apart so as to increase the length of the dock when required, or if not

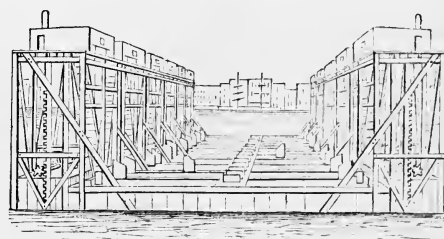

Fig. 7.—New York Sectional Dock.

of sufficient buoyancy other sections may be added. The advantage claimed for this dock is, that the buoyancy of each section may be so regulated as to bear with equal pressure against all parts of the ship's bottom, so that if she has been warped there will be no strain. On the other hand, it is stated that irregularities of pressure caused by swells from steamboats or otherwise more or less reduce this advantage. Advantage it certainly has in the facility with which it may be repaired, by taking up any section and placing it upon the dock formed by the remainder.—The arrangements for docking at the navy yard of Philadelphia consist of a floating sectional dry dock, and a permanent stone basin with two marine railways. The sectional dock consists of nine sections, which may be increased in number, each section being 105 ft. long and 32 ft. wide, and the pontoons 11 ft. deep. There are three pumps at each end of each section, moved by two engines of 20 and two of 12 horse power. The bottom of the basin is 350 ft. long and 226 ft. wide, and will hold 10 ft. 9 in. of water at mean high tide. The dry dock at San Francisco is a sectional dock similar to the one at Philadelphia, but is

a little larger. The dock at Portsmouth is a balance dry dock, 350 ft. long, 105 ft. wide, and 38 ft. deep. There is also a basin 350 ft. long and 120 ft. wide, with two marine railways. At Pensacola the docking arrangements are precisely the same as at Portsmouth.—There is in use at New York a so-called hydrostatic screw dock, in which vessels are raised by hydrostatic power applied to screws to which chains are attached, supporting strong platforms consisting of trusses of timber. The first dock of the kind was worked by screws alone, and was patented by Elisha Turner in 1825. The improvements by which hydrostatic power was applied were patented by Zebedee Ring in 1836. The screws which suspend the chains are fixed in a drawing frame which rests upon pins at either side. The drawing frames are propelled by horizontal hydrostatic cylinders. The platform upon which the vessel rests may be adjusted to the bottom by raising or lowering each section or truss as may be required.

**DOCTOR** (Lat., a teacher), a person who has taken all the degrees of a faculty, and is empowered to teach and practise it. It is bestowed by universities and colleges as an honorary distinction. The doctorate and the degrees which conduct to it were instituted early in the 12th century. The first ceremonious installation of a doctor was at the university of Bologna, when Bulgarus was promoted to the doctorate of the civil and canon law. The learned Irnerius, one of the revivers of the Roman law at that time, composed the formulary which has been followed since, and which gives great solemnity to the reception of the degree. The usage was immediately adopted by the university of Paris, which in 1145 conferred the degree of doctor upon Peter Lombard and Gilbert de la Porrée. The title and degree of doctor were in use in England under King John, about 1207. In Germany during the middle ages a doctor of law enjoyed the same privileges as knights and prelates. The first doctors were only of law and theology; medicine was afterward added; and in 1340 in the university of Paris the four faculties of law, theology, medicine, and the arts or letters were organized as they are now. At Oxford and Cambridge, and recently also in some of the German and American universities, diplomas of doctor of music have been given. The title of doctor has occasionally been bestowed upon women. In 1787 the university of Göttingen decreed the title of doctor of philosophy to Dorothea Schlözer; in 1817 the university of Giessen gave the title of doctor of medicine to Mariane Charlotte von Siebold; in 1827 the university of Marburg pronounced Johanna Wyttenbach doctor of philosophy. Still more recently women have received the title of doctor of medicine from foreign and from American schools. In the universities of Oxford and Cambridge, and in most of the continental universities, a student who is to receive the

degree of doctor has to prepare one or more theses, which in Germany are called the inaugural theses. In the United States the title is conferred upon those of eminent learning or ability in their profession, without demanding from them any learned exercise in return, excepting in the medical profession, where it is bestowed at the end of a course of study. The title had an existence outside of the universities during the middle ages, and was bestowed upon every one of singular learning. Thus Alexander of Hales was called the irrefragable doctor; Thomas Aquinas, the angelic doctor, Bonaventura, the seraphic doctor; Duns Scotus, the subtle doctor; Roger Bacon, the admirable doctor; William Occam, the singular doctor; Denys le Chartreux, the ecstatic doctor; and Alain de Lille, the universal doctor. The title of doctor has been given to some of the fathers of the church whose teachings have the highest authority. At an early period there were accounted four doctors of the Greek church, St. Athanasius, St. Basil, St. Gregory Nazianzen, and St. John Chrysostom; and also of the Latin church, St. Augustine, St. Jerome, St. Gregory the Great, and St. Ambrose. Pope Pius V. assigned the fifth place among the Latin doctors to St. Thomas Aquinas, and Sixtus V. gave the sixth place to St. Bonaventura. St. Bernard was added to the series by Pius VIII. The title of doctor of the law existed among the ancient Jews. Those who figure in the Talmud are called doctors of the Talmud, or distinctively doctors of the Mishnah (*tanaim*) and of the Gemara (*amoraim*), according to the divisions of that book in which they appear. They were also called rabbis.—In England, Germany, and the United States the title doctor of divinity (D. D.) or doctor of sacred theology (S. T. D.) is conferred, generally as an honorary degree, upon distinguished teachers of Christianity. The degrees of doctor of philosophy (Ph. D.) and doctor of civil and canon law (J. U. D., *juris utriusque doctor*) are conferred by German universities for proficiency in studies. In England and the United States, the title of doctor of laws (LL. D.) is conferred as an honorary degree upon those who have acquired distinction in any department of learning or public affairs. In place of this the university of Oxford confers the corresponding degree of doctor of civil law (D. C. L.).

**DOCTORS' COMMONS**, the college of civilians in London, near St. Paul's churchyard, founded by Dr. Henry Ilarvey, dean of the arches, for the doctors of the civil law, burned down in the great fire of 1666, rebuilt in 1672 at the cost of the profession, and taken down in 1867. In the common hall were held until 1858 the sessions of the court of arches, the chief ecclesiastical court of the province, the archdeacon's court, the prerogative court for the hearing of testamentary causes, the faculty court, the court of delegates, and the court of admiralty. The most interesting part of

doctors' commons was the prerogative will office, in which were kept all wills admitted to probate in the prerogative court of the archbishop of Canterbury, which had jurisdiction over nearly all such business in the kingdom. The original testaments preserved here dated from 1483, the copies from 1383. Great care was taken to prevent mutilation. No stranger was allowed to make a memorandum from either the wills or the index; extracts or transcripts, when wanted, were written out by the attending copyists, but any person was allowed to examine a will on payment of the regular fee. Attached to the college were 34 proctors, who gave licenses for marriages, and performed the duties of solicitors. Only doctors of the civil law were allowed to practise in the courts held in doctors' commons. By acts of parliament passed Aug. 25 and 28, 1857, and Aug. 2, 1858, the importance of doctors' commons was in great measure destroyed. Jurisdiction in all testamentary, divorce, and matrimonial cases was transferred from the ecclesiastical tribunals to a court of probate, and a court for divorce and matrimonial causes. A central office for the registry of wills was opened, with branches in the chief towns of the kingdom, and judges of ecclesiastical courts were ordered to transmit to it all wills in their possession. Serjeants and barristers at law were admitted to practise in the probate court, but compensation was made to the displaced proctors to the amount of one third of the average profits of their business, payable during their natural lives, and officers of the ecclesiastical courts were transferred to corresponding positions in the new probate court. Marriage licenses were to be granted as before. The same restrictions relative to the examining of wills continued in force in the new registry office, and drew forth a remonstrance from literary men early in 1859. The jurisdiction of the court of delegates is now transferred to the judicial committee of the privy council, but the court of arches, the archdeacon's court, and the faculty court still exist for the hearing of ecclesiastical causes.

**DOCTRINAIRES**, a French constitutionalist party, which originated after the restoration of the Bourbons, and represented the interests of liberalism and progress, as opposed to the ultra royalists, in the executive government and legislature. Royer-Collard, the duke de Broglie, and Guizot were its foremost leaders. They were called *doctrinaires* because they insisted that the state should be administered in accordance with rational doctrines and demonstrable political utility, rather than with party formulas or the passion of the hour. After the revolution of July, 1830, when they came into power, they assumed a conservative position in antagonism with the republicans and radicals. After February, 1848, the *doctrinaires* were no more heard of.

**DOD.** **I. Daniel**, an American machinist, born in Virginia, Sept. 28, 1788, died in New York,

May 9, 1823. His father was distinguished for his versatile mechanical genius. Daniel received a thorough scientific education, and declined an appointment as professor of mathematics in Rutgers college to devote himself to the manufacture of engines for steamboats, then a new invention. He settled at Elizabethtown, N. J., and built for the steamboat Seahorse an engine of different construction from any former one; it proved superior to them all, and was generally adopted. In 1818 he built an engine for the steamship Savannah, which the next year made the first voyage across the Atlantic ever performed by a steamship, and returned in safety after visiting England and Russia. The experiment was peculiarly unprofitable, and was not immediately repeated. He removed in 1821 to New York city, where he was reputed the most successful engine builder in the United States. In 1823, having altered the machinery of a steamboat, he went on board of her to witness in a trial trip on the East river the effect of his changes. The boiler exploded, and so severely injured Mr. Dod that he survived but a few days.

**II. Albert Baldwin, D. D.**, an American scholar, son of the preceding, born in Mendham, N. J., March 24, 1805, died in Princeton, Nov. 20, 1845. He graduated at Princeton college in 1822, and after spending more than three years in private teaching in Fredericksburg, Va., returned to Princeton in 1826 as a student in the theological seminary. From 1827 to 1829 he was a tutor in the college, and in 1830 was elected professor of mathematics, continuing in this post till his death. He lectured upon architecture and political economy, and wrote occasional review articles, especially for the "Biblical Repertory." An article by him in answer to objections urged against capital punishment was adopted by a committee of the New York legislature as their report.

**DODD, William**, an English clergyman, born at Bourne, Lincolnshire, in May, 1729, executed in London, June 27, 1777. He studied at the university of Cambridge, where he distinguished himself as a writer both of prose and poetry. He left Cambridge for London in 1750, and the next year married a woman who possessed neither virtue nor fortune, and whose tastes were even more extravagant than his own. He was ordained deacon the same year, and priest in 1753, and was appointed to the vicarage of West Ham, near London, where he obtained great success by his impressive eloquence. His reputation so increased that he was quickly called to London as a preacher, retaining his former benefice. He now abandoned himself to extravagance and excesses. In the hope of being able to meet his increasing expenses, he multiplied his labors as editor and author, and in the course of several years published various original pieces, translations, and new editions of esteemed works. He was intrusted in 1763 with the care of the education of Philip Stan-

hope, afterward earl of Chesterfield, and obtained an appointment as one of the chaplains of the king. In 1766 he took the degree of LL. D. at Cambridge. Pursued by his creditors, and ambitious of a still higher position than he had yet obtained, he wrote to the wife of the lord chancellor Apsley an anonymous letter, offering her £3,000 if by her influence he might be promoted to the rectory of St. George's, Hanover square. This letter, being communicated to the chancellor, laid before the king, and traced to the author, caused his name to be stricken from the list of the royal chaplains. He fled to Geneva, where the young Lord Chesterfield was then residing, who gave him money to satisfy his creditors, and presented to him a living in Buckinghamshire. But Dodd went directly with his money to France, where he spent it recklessly. On his return to England in 1776 he resumed his pastoral functions, and preached with fluency and unction. His last sermon was at the Magdalen chapel, Feb. 2, 1777. Two days after this he forged a bond upon Lord Chesterfield for £4,200, for which he was tried at the Old Bailey and condemned to death. Though he refunded the money, and was recommended by the jury to the royal clemency, and though numerous noble protectors, many clergymen, and a petition from the city of London bearing 23,000 signatures, prayed for the interference of the crown, he was executed at Tyburn. Of his many writings, the "Reflections on Death" (1763) and the "Thoughts in Prison," a poem in blank verse, written during the progress of his trial, are alone not forgotten.

**DODDRIDGE**, a N. W. county of West Virginia, drained by Hughes river; area, about 300 sq. m.; pop. in 1870, 7,076, of whom 35 were colored. The land is mostly hilly and adapted to pasturage. The Parkersburg division of the Baltimore and Ohio railroad crosses it. The chief productions in 1870 were 15,879 bushels of wheat, 113,064 of Indian corn, 18,723 of oats, 14,167 of potatoes, 4,649 tons of hay, and 113,649 lbs. of butter. There were 1,815 horses, 1,987 milch cows, 2,782 other cattle, 7,183 sheep, and 3,904 swine. Capital, West Union.

**DODDRIDGE**, Philip, an English clergyman, born in London, June 26, 1702, died in Lisbon, Oct. 26, 1751. Left an orphan at the age of 13, he was sent to a private school at St. Albans, where he made the acquaintance of Dr. Samuel Clarke, who became interested in him for his love of learning. The duchess of Bedford offered to defray the expenses of his education at either university, a proposal which he declined on account of the implied condition that he should become a clergyman in the church of England. In 1719 he entered a dissenting academy at Kibworth to study theology. From 1722 to 1729 he fulfilled pastoral duties at Kibworth and the neighboring town of Market Harborough, and in that retired district pursued his studies. In 1729 he took

charge of the academy where he had been himself educated, and removed it first to Market Harborough, and then to Northampton, whither he had been invited as pastor. At this academy the most distinguished dissenting ministers near the middle of the last century were educated. Dr. Doddridge presided over it for 20 years, and acquired a high reputation as a preacher and author. In 1750 his constitution, always feeble, began to show signs of decline, and he sailed to Lisbon, where he died 13 days after his arrival. His most popular and useful works are "The Rise and Progress of Religion in the Soul," and the "Family Expositor," containing a version and paraphrase of the New Testament, with notes. He also published several volumes of sermons, "The Principles of the Christian Religion," a "Treatise on Regeneration," and several minor works. He is the author of numerous hymns included in the standard collections. His "Course of Lectures on the Principal Subjects in Pneumatology, Ethics, and Divinity" was published posthumously (London, 1763), and gives the outlines of a system of metaphysics and divinity. His works were collected in 10 vols. (Leeds, 1802), and his "Private Life and Correspondence," by one of his descendants, appeared in 5 vols. (London, 1831). Accounts of his life were also published by his contemporary Job Orton, and his pupil Dr. Kippis.

**DODGE**. I. A S. central county of Georgia, formed since the census of 1870, bounded S. W. by the Ocmulgee river, and intersected by the Little Ocmulgee; area, about 500 sq. m. The surface is generally level and sandy. Pine forests abound. The Macon and Brunswick railroad traverses it. Capital, Eastman. II. A S. E. county of Wisconsin, drained by Rock river and several smaller streams; area, 936 sq. m.; pop. in 1870, 47,035. There are prairies in various parts, interspersed with oak openings, and covered here and there with small clusters of burr and pin oaks. The valleys of the streams are occupied by extensive forests of oak, ash, elm, and maple. The soil is calcareous and highly fertile. Horicon lake is in the N. part. The Wisconsin division of the Chicago and Northwestern railroad and the Northern and La Crosse divisions of the Milwaukee and St. Paul railroad cross it. The chief productions in 1870 were 2,294,538 bushels of wheat, 25,009 of rye, 629,020 of Indian corn, 909,648 of oats, 96,233 of barley, 354,744 of potatoes, 70,258 tons of hay, 1,153,272 lbs. of butter, and 229,984 of wool. There were 13,550 horses, 16,311 milch cows, 14,549 other cattle, 59,138 sheep, and 21,017 swine; 6 manufactories of agricultural implements, 23 of carriages, 10 of barrels and casks, 11 of furniture, 2 of pig iron, 4 of woollen goods, 14 of saddlery and harness, 5 of pumps, 4 saw mills, 12 flour mills, and 6 breweries. Capital, Juneau. III. A S. E. county of Minnesota, drained by affluents of the Zumbro river; area, 432 sq. m.; pop. in 1870, 8,598. The surface

is undulating or nearly level prairie, and the soil fertile. The Winona and St. Peter railroad crosses it, and the Milwaukee and St. Paul railroad touches the S. W. corner. The chief productions in 1870 were 634,741 bushels of wheat, 81,277 of Indian corn, 384,528 of oats, 47,150 of barley, 36,569 of potatoes, 19,863 tons of hay, 27,667 lbs. of butter, and 20,808 of wool. There were 2,877 horses, 3,208 milch cows, 4,659 other cattle, 5,889 sheep, and 2,824 swine; 7 flour mills, 1 saw mill, 1 manufactory of furniture, 4 of carriages, 1 of agricultural implements, and 1 brewery. Capital, Mantorville. **IV.** An E. central county of Nebraska, bounded S. by the Platte river, and intersected by the Elkhorn; area, about 600 sq. m.; pop. in 1870, 4,212. The surface is level and the soil fertile. The Union Pacific railroad passes through the S. part. The chief productions in 1870 were 86,181 bushels of wheat, 123,466 of Indian corn, 116,252 of oats, and 13,927 of potatoes. There were 1,382 horses, 1,264 milch cows, 2,025 other cattle, and 2,386 swine. Capital, Tremont.

**DODINGTON, George Bubb**, Baron Melcombe, an English politician, born in Dorsetshire in 1691, died July 28, 1762. He was educated at Oxford, and in 1715 was chosen to parliament for Winchelsea. His talents soon attracted attention, and after accompanying Sir Paul Methuen to Madrid, he was made envoy extraordinary to Spain, returning in 1717. On the death of his uncle George Dodington in 1720, he came into possession of a large estate in Dorsetshire, took the name of Dodington, and erected at the cost of £140,000 a magnificent residence, where he entertained the leading literary men of the time. In politics he was a whig, and joined himself to Walpole; but when that minister refused him a peerage, he joined the opposition. Resuming his relations with Walpole, he received several valuable appointments; but again joining the opposition, he was conspicuous in the assaults on Walpole's ministry which resulted in its overthrow, and was after some time made treasurer of the navy. Again changing his views, he joined the faction of Frederick, prince of Wales, in 1749, and received from him the promise of a peerage and a cabinet office, to be conferred when the prince should become king. The prince and Dodington settled the former's first ministry; but in the midst of their scheming the prince suddenly died. In 1755 he was once more appointed treasurer of the navy, but soon lost the office. In 1761 he obtained the object of his life, being made Baron Melcombe Regis, through the favor of Lord Bute. This success he did not live long to enjoy, and on his death the title became extinct. His estates fell to Richard Grenville, Earl Temple, and his personal property was bequeathed to Thomas Wyndham, whose relative, Henry P. Wyndham, published Dodington's "Diary" in 1784. This diary was kept, with some breaks, from March 8, 1749, to Feb. 6, 1761, and af-

fords a lively picture of the parties, politics, and public men of the last years of George II.'s reign, of the political corruption of the time, and of that of the author himself. Several of the author's political papers are attached to it. The volume has been frequently reprinted.

**DODO** (*didus ineptus*, Linn.), a large bird of the island of Mauritius, at present placed in a subfamily of the order *columba*, or pigeons. It has become extinct within two centuries. It was discovered by Vasco da Gama in 1497, and was mentioned by various voyagers, from Jacob van Neck and Wybrand van Warwijk in 1598, to Captain Talbot in 1697. In the work of Strickland and Melville on "The Dodo and its Kindred" (4to, London, 1848) are given many quaint descriptions and figures of the bird, which it appears was not uncommon in the 17th century, and was frequently used as food by the crews of vessels. In 1638 François Cauche says that he saw in Mauritius birds "larger than a swan, covered with a black down, with curled feathers on the rump,

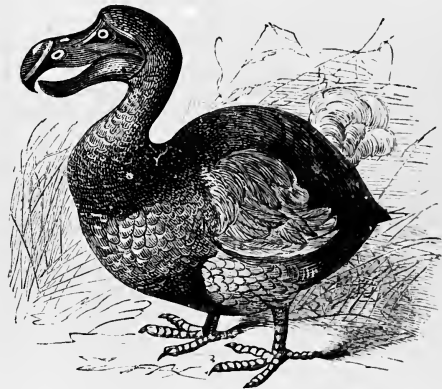

The Dodo (*Didus ineptus*).

and similar ones in place of wings; that the beak was large and curved, the legs scaly, the nest made of herbs heaped together; that they lay but one egg of the size of a halfpenny roll or that of a pelican, and that the young ones had a stone in the gizzard." In the same year a living specimen was exhibited in London, and described by Sir Hamon Lestrange as a "great fowle, somewhat bigger than the largest turkey cock, and so legged and footed, but stouter and thicker and of a more erect shape, colored before like the breast of a young fesan, and the back of dun or deare color." In 1644 the Dutch began to colonize the island, and these birds were soon exterminated by the colonists, and by the dogs, cats, and rats, which devoured the eggs and the young in the nests; after the French took possession in 1715 the dodo is no longer mentioned as a living bird. This is a most remarkable and clearly proved instance of the extinction of an animal by human agency; and as yet the data for determining the species are less than

those left by many animals which perished ages ago from geological causes. Besides the rude drawings of the early voyagers given in Strickland's work, there are at least six oil paintings which are no doubt faithful copies of the living originals. The first of these paintings, the one copied in all books on natural history, and now in the British museum, is anonymous, but probably by one of the artists who painted the following ones; there are three pictures by Roland Savery, one at the Hague, another in Berlin dated 1626, and the third in Vienna dated 1628; a fifth painting is in the Ashmolean museum, by John Savery, dated 1651; and a sixth in the gallery of the duke of Northumberland, at Stion House, painted by Goemare, and dated 1627. The principal remains of the dodo are a foot in the British museum, and a head and foot in the Ashmolean museum at Oxford, England, rendered familiar by numerous casts; the latter are all that is left of the specimen in Tradescant's museum, and all that was saved from the flames which consumed the decayed specimens by order of the trustees in 1755; the head preserves the beak and nostrils, the bare skin of the face, and the partially feathered occiput; the eyes are dried within the sockets, but the horny end of the beak is gone. A cranium exists in the museum at Copenhagen; a collection of bones at Paris, much incrustured with stalagmite, carried there in 1830; and others sent by Mr. Telfair to the Andersonian museum at Glasgow and to the London zoological society in 1833. The latter included a tibia and the head of a humerus of large size, with a broad articulating surface and a sudden reduction of the size of the shaft. The generic characters are a strong bill, much longer than the head, with the culmen straight at first and then arched to the tip, which is acute and overlaps the lower mandible; the latter has the gonyes short and suddenly curved upward; the nostrils are in the membranous portion (which occupies two thirds of the bill), oblique and exposed; the wings imperfect; the tail apparently a tuft of five feathers, broad and curved upward; the tarsi robust, moderately long, and scaled; the outer toe is shorter than the inner, and the anterior toes are all free at the base; the hind toe is long, on the same plane with the others, and scaled; the claws are short, strong and blunt. Cuvier ranked the dodo with gallinaceous birds; others have traced out its analogies with the ostrich and with the penguin. Most writers, before the work of Strickland, considered it a modified form of raptorial bird. Reinhardt of Copenhagen first referred the dodo to the pigeon family, and Strickland and Melville followed out this idea. They consider it a frugivorous terrestrial pigeon, colossal and brevipennate, coming near in the bill to the genus *treron* (Vieill.; *vinago*, Cuv.). The chief external characters of resemblance are the soft, depressed, and vascular nature of the long basal

portion of the bill; the extent of the bare skin around the eyes and forehead; the hooked and compressed corneous portion of the upper mandible, overhanging the lower; the position of the nostril in the middle of the beak, and near its lower margin; the sudden sinking from the forehead to the beak, and the rapid narrowing in front of the orbits; the short, robust tarsi, and expansion of the lower surface of the toes; the low plane of the hind toe; the relative lengths of the toes as compared with the ground pigeons, the absence of interdigital webs, and the short blunt claws. Among internal characters, gathered from the narratives of voyagers and the paintings of the bird from nature, are the presence of a large crop, a very muscular gizzard, the palatableness of the flesh, and the laying of a single egg. Besides these characters are the absence of the vomer; the form and direction of the bones, processes, and foramina of the skull; the form of the metatarsal and tarso-metatarsal bones, processes, and canals; and especially the passage of these canals on the outside of the posterior tarsal ridge. Mr. Allis detected only 11 sclerotic plates, as in the pigeons, no other birds having so small a number. Its food was probably dates, cocoanuts, mangoes, and such other fruits as would fall from the tropical trees. Strickland calls it "a young duck or gosling enlarged to the dimensions of a swan; . . . a permanent nestling, clothed with down instead of feathers, and with the wings and tail so short and feeble as to be utterly unsubserving to flight." While Strickland was preparing his work in England, Dr. S. Cabot, jr., of Boston, published a paper in the "Journal of the Boston Society of Natural History" (vol. v., p. 490), entitled "The Dodo a Rasorial and not a Rapacious Bird;" in this he comes to the same conclusions as the first mentioned author, and without any knowledge of his views. He says "that the dodo was a gigantic pigeon, and that, as its general shape, feathering, &c., resemble more strongly the young than the adult pigeon, we may perhaps be allowed to surmise that it properly belongs to an earlier epoch than the present, and has become extinct because its time was run." Prof. Brandt of St. Petersburg, in 1848, maintained the affinity of the dodo to the *charadriadae* or plovers, which he styles pigeoned-formed or dove-like waders. The testimony seems overwhelming in favor of the columbine affinities of the dodo.—In the island of Rodriguez lived another large brevipennate bird, the *solitaire*, allied to the pigeons.

**DODONA**, an ancient city of Epirus, in N. Greece, celebrated as the seat of the most ancient oracle of Greece, which ranked with those of Delphi and Ammonium. It is the only place of great celebrity in Greece of which the situation is not exactly known; no vestige of it can be discovered. Leake conjectures that its site was at the S. end of Lake Janina (anc. Pambotis); others place it near the source

of the Oropus. Before the erection of the temple, which was dedicated to Jupiter, the mysterious sayings of the deity were uttered from the whispering branches of a large oak tree; and the old poets ascribed to the oak grove at Dodona the power of speech. The temple was destroyed by the Ætoliens under Dorimachus, 219 B. C., but it was rebuilt, and is mentioned by Pausanias as standing in the 2d century of our era. A town of this name existed as late as the 6th century. According to Lucretius, the fountain near the temple at Dodona was inflammable.

**DODSLEY, Robert**, an English publisher and author, born at Mansfield, Nottinghamshire, in 1703, died in Durham, Sept. 25, 1764. He was originally a servant, but produced in 1732 a volume of poems, under the title of "The Muse in Livery," and subsequently a dramatic piece called "The Toy Shop," which met with the approbation of Pope, and was acted with great success at Covent Garden theatre in 1735. He then became a bookseller. Patronized by Pope, his shop became in time one of the leading establishments in the British metropolis. In 1737 he brought out a farce styled "The King and the Miller of Mansfield," which was received with applause at Drury Lane; and a few years subsequently a ballad farce entitled "The Blind Beggar of Bethnal Green." In 1746 he projected "The Museum, or the Literary and Historical Register," which numbered among its contributors some of the most eminent literati of the day. In 1748 he started another periodical called "The Preceptor," the preface of which was written by Dr. Johnson, and in 1749 he paid the latter 15 guineas for his "Vanity of Human Wishes." In 1750 he published "The Economy of Human Life," which was ascribed by some to Lord Chesterfield. In 1758 his tragedy of "Cleone" was represented at Covent Garden theatre, on which occasion Dr. Johnson declared that "if Otway had written it, none of his other pieces would have been remembered." It went through four editions in a year. In the same year, in connection with Edmund Burke, he started the "Annual Register," which is still published. He was the first to collect and republish the "Old English Plays" (1st ed. edited by T. Coxeter, 1744; 2d ed. by Isaac Reed, 12 vols. 8vo, 1780), by his selection of which his name is now most frequently recalled. He retired from business in 1763 with a handsome fortune. His collected writings were published under the title of "Miscellanies, or Trifles in Prose and Verse" (2 vols., 1745 and 1777).

**DODWELL, Edward**, an English author, born about 1767, died in Rome, May 14, 1832. He published "A Classical and Topographical Tour through Greece during the years 1801, 1805, and 1806" (2 vols. 4to, 1819), and made numerous drawings of ruins and scenery in Greece and Italy, some of which were published after his death under the title of "Views

and Descriptions of Cyclopean or Pelasgic Remains in Greece and Italy, with Constructions of a later Period."

**DODWELL, Henry**, an Irish writer, born in Dublin about 1641, died at Shottesbrook, Berkshire, June 7, 1711. He graduated at Trinity college, Dublin, and settled in London in 1674. He was for about three years Camden professor of history at Oxford, but lost the office in 1691 by refusing to take the oath of allegiance to William and Mary. He is known especially as a writer on classical and religious subjects. Among his works are: *Annales Thucydidei et Xenophontei*; *Annales Velleiani, Quintiliani, Statiani*; *De Veteribus Græcorum, Romanorumque Cyclis, obiterque de Cyclo Judeorum ac Ætate Christi, Dissertationes*; and "An Epistolary Discourse, proving from the Scriptures and the first Fathers that the Soul is a principle naturally mortal, but immortalized actually by the pleasure of God, to punishment or to reward, by its union with the divine baptismal Spirit; wherein it is proved that none have the power of giving this divine immortalizing Spirit since the Apostles, but only the Bishops."—See "Life of Dr. Henry Dodwell," by Francis Brokesby (London 1715).

**DOES, Jacobus van der**, the elder, a Dutch painter, born in Amsterdam, March 4, 1623, died there, Nov. 17, 1673. After visiting Paris, he spent several years in Rome, where he was assisted by fellow artists. He was celebrated for his pictures of animals, especially sheep and goats, in connection with landscapes. His son SIMON (1653-1717) excelled in the same branch of art; and another son, JACOBUS the younger, born in 1654, showed great talent as a historical painter, and died in Paris at the age of about 38.

**DOG**, a digitigrade carnivorous mammal, belonging to the genus *canis*, and to the family *canidæ*, which also include the wolf, fox, and jackal. The species of this family are so nearly alike in structure that the genera *canis*, *lupus*, *vulpes*, &c., have been established on characters which are considered of inferior importance in other families; even the intellectual and instinctive faculties have been employed by F. Cuvier and others in distinguishing the species, the domestic dogs being regarded as derived from several distinct though nearly allied wild canines. Except in the size of the bones, there is nothing in the osteology of this family which can be made characteristic of the wild species or of the domestic races when compared with each other, though as a family group they are quite distinct from other digitigrades. In the skulls, the several species of wolf differ more from each other than do many domestic dogs from the wolves; as a general rule, the cranial cavity bears a greater proportion to the face as the intelligence of the animal is more marked. The teeth of dogs, which are largest in the wild species, consist, in the upper jaw, of six incisors in the intermaxillary bones; two

canines, strong, curved, and separated by an interval from the incisors; and six molars on each side, the first three, in interrupted series, being small, but with cutting edges, and called also false molars; the fourth or carnivorous tooth is bicuspid, with a small tubercle anteriorly on the inner side; the fifth is less cutting, bicuspid, with a large internal tubercle; the sixth and last is small and tubercular. In the lower jaw there are six incisors; two canines, continuous in the series, and seven molars on each side, of which four are false, the fourth being bicuspid; the fifth or carnivorous tooth has its tubercular third lobe entirely posterior; behind this are two tubercular teeth, the last being very small and frequently absent in the adult animal. The incisors are regular, the outer being the largest, and nearly perpendicular in the upper jaw; the lower canines shut in front of the upper; the tubercular character of the other teeth indicates a less carnivorous propensity than in the cat family, and that their natural diet is not exclusively animal, being better suited for carrion and broken bones than for the flesh of a living prey. In some species, as the buansuah and the dhole, the second tubercular tooth is constantly wanting, according to Hamilton Smith. The brain cavity is comparatively small; the crests of the skull and the large temporal fossæ indicate powerful muscles of mastication; the eyes are directed forward; the nostrils are largely opened in a movable glandular muzzle; the tongue is soft, thin at the edges, and capable of considerable extension beyond the teeth, as is seen during rapid breathing in warm weather; the pupil is round, as in other diurnal *canidæ*. The fore feet have five toes, the hind feet four or five; the two middle toes are the longest and equal; the fifth toe, when present, does not reach the ground; the claws are blunt, strong, not retractile, and formed for digging; the soles are furnished with tubercles, and in some arctic dogs with hair. The hair is soft and woolly near the skin, longer and coarser externally; some of the dogs of India have the skin entirely naked, this condition originating probably from some mangy disease. The tail is generally long, and is curled upward. The number of mammae varies from six to ten; the size, form, and color are different according to the variety. The young open their eyes on the 10th or 12th day; the first teeth begin to be shed at the fourth month, and the growth ceases at about two years of age; gestation is about nine weeks, and the duration of life is about 10 years, though sometimes prolonged to 20. Though strong, they are not courageous in proportion to their strength; hearing is acute, and smell and vision are proverbially delicate, the former in the bloodhound, the latter in the greyhound; taste is so dull or perverted that even luxuriously fed pets will not disdain a meal of decaying flesh. Dogs are not so cleanly in their habits as cats; they drink by lapping, require water often, and turn round

frequently before lying down; their bark is very different from the howl of wild canines, and expresses by its intonation fear, sorrow, anger, joy, and other feelings. All canines seem to have a natural antipathy to the cat family; and all, both wild and domesticated, and the nearly allied hyæna, are subject to hydrophobia.—There are several species of wild dogs in different parts of the earth, all of which may have been pressed into the service of man; the crossings of these with each other, with the wolf in the north, the jackal in the east, the aguara canines in the south, the fennec in Africa, and the fox everywhere, with the care of man to develop special breeds according to his wants, are sufficient to account for all the varieties of our domestic dogs. Dogs differ in stature, in the shape of their ears and tails, and in the number of their caudal vertebrae; some have an additional claw on the hind foot, or an extra false molar tooth on one side; the hair differs in color, texture, and length; and all these differences may remain as permanent varieties, like some human races, as long as the circumstances which gave rise to them continue essentially the same. When restored to the wild state, they approximate more or less closely to their original type, whether it be wolf, fox, jackal, or other wild canine. Hamilton Smith classes dogs according to their apparent affinities with wild canines in corresponding latitudes: the arctic dogs with wolves; the dogs of the south with the jackal in the old world, and with the aguara canines in South America. The Indian dogs may be traced to the prairie wolf and the Mexican coyote, and in Asia to the jungle koola. Whatever may have been their originals, it is altogether probable that the primitive dogs, like the other domestic animals, were very different from any of the present races, and perhaps from any now existing canines.—The first genus of wild dogs is *lyciscus* (Smith), embracing the prairie wolf and coyote of North America, and the koola of India; the head is broad, the muzzle pointed, ears erect, fur short, tail bushy; stature about 26 in.; the disposition is more peaceable than that of the wolf; the voice barking; they are gregarious and live in burrows. It is probable that the aboriginal Indian dog is derived from the first two; the color is ashy gray, with some white on the tail and breast; when hunting in packs, these animals are hardly to be distinguished from domestic dogs. They are named *L. latrans*, *L. cagottis*, and *L. vigris*. The red wild dogs, forming the genus *chryseus* (Smith), are found in the warmer parts of Asia, Africa, and the Australian islands; the muzzle is less pointed than in *lyciscus*, and the tail less bushy; they are shy and fierce, seldom burrow, hunt in troops, and bark, and are about 24 in. high; they want the second tubercular tooth in the lower jaw, and are said to have hairy soles; they destroy many of the young of the larger cats; they differ from



wolves and jackals in their habits and instincts, and approximate the domestic dog in the small size of the anal glands. The buansuah of Nepaul (*C. primævus*, Hodg.) is of a deep rust color above and yellowish below; it is intermediate in size between a wolf and a jackal, hunting by day or night by the scent chiefly, in small troops; there are several varieties in the wooded mountains of British India. (See BUANSUAH.) The dhole of India (*C. scylax*, Smith) is more slender than the buansuah, higher on the legs, with a sharper muzzle, long close-haired tail, and large dark ears; the color is a light bay. The dhole of Ceylon (*C. Ceylonicus*, Shaw) is an allied, if not the same species. The pariah cur dogs of India are not merely degraded mongrels, but are the offspring of an indigenous wild species living in the jungles and in the lower Himalaya range; this resembles the jackal more than the wolf, but is more bulky in body and lower on the legs; the voice is yelping and howling. Other red wild dogs are found in Sumatra and Java. The Austra-



Dingo.

lian dingo (*C. Australasica* of authors) is a wild dog which has been partially domesticated by the natives, and is no doubt an indigenous inhabitant, not introduced by man; in its native wilds it howls in a melancholy manner, and it is more than a match for a domestic dog of the same size; it hunts in small packs, sometimes in pairs, and is very active and fierce. It stands about 2 ft. high; the color above is fulvous spotted with white, paler on the sides and throat, and whitish below; it carries the tail horizontally, and runs with the head high and the ears turned forward. The genus *thous*, of which the typical species is the wild dog of Egypt (*C. anthus*, F. Cuv.), resembles the wolf on a small scale, being not more than 18 in. high, of a light structure, with rather short tail, close, ochry fur, barred or pencilled with black and white; the species do not burrow, and are not gregarious, seldom howl, and have no offensive smell; they all have the tip of the tail black, and prefer rocky, sandy districts,

where there are bushes and water. Hamilton Smith is of the opinion that the greyhound of the desert is originally derived from one of the species of this section. It is found from Egypt and Arabia to the Cape of Good Hope. South America when first discovered by the Spaniards had its indigenous canines, all with a tendency to elliptical pupils, though less so than in true foxes; among these are the aguara dogs, genus *ducicyon* (Smith). These are between the wolf and the fox in form, with bulky body and short legs; they burrow and are more social and gentle than the aguara wolf (*C. jubatus*, Desm.). This group seems to represent the *thous* of the old world, though the forehead is more rounded, and the tail consists of an imperfect brush; the prevailing color is fulvous brown, often with a hoary tinge; the face looks like that of the fox; they are not very shy, and are capable of being domesticated; they are great thieves, with a propensity to conical objects of no use as food; besides the usual articles of diet, they will eat fish, crabs, reptiles, insects, small birds, and even mollusks and berries; they are generally silent and hunt by day or by moonlight; they are good swimmers. Several species are described, ranging from Surinam to the Falkland islands; the domesticated specimens differ but little from the wild originals, except in the tail being less bushy; the average height is 15 in.; there are five toes to each foot, and the gape of the mouth is large and wolf-like; they hunt pacas, agoutis, and wild gallinaceous birds. All these wild dogs cross with the domesticated ones of the country, forming the most complicated intermixtures.—Certain varieties have relapsed into a wild state. In Asia Minor there is a race of these feral dogs (as Hamilton Smith calls them), of nearly the size of the local wolf, and resembling the shepherd's dog except that they have a more bushy tail, sharper nose, and the fur reddish gray, and that they hunt in packs in open day. A smaller breed is found in Russia. In Santo Domingo there is a large feral dog of the race of hounds formerly used by the Spaniards in their western conquests; it is about 28 in. high, with a head like a terrier, and the general color pale bluish ash; its scent is very fine, and it follows its prey with great speed, attacking it with ferocity; flocks sometimes suffer from its depredations; it is believed that it was introduced into Spain from the north, such is its resemblance to the Danish dog. In the pampas of South America are troops of feral dogs, a mixture of all the breeds of the country; their ears are erect as in true wild canines; they are bold and cunning, destroying many of the young of the wild herds of cattle and horses; when redomesticated, they are remarkable for their courage, sagacity, and acute sense of smell.—Of the true domesticated races, the arctic dogs of both hemispheres are large, of wolfish aspect, with pointed nose, erect ears, and long hair of mixed black and white; they are fierce,

bold, and strong; they swim excellently, burrow in the snow, and will drag the native sledges for hours at a time several miles an hour. The arctic voyages have made read-

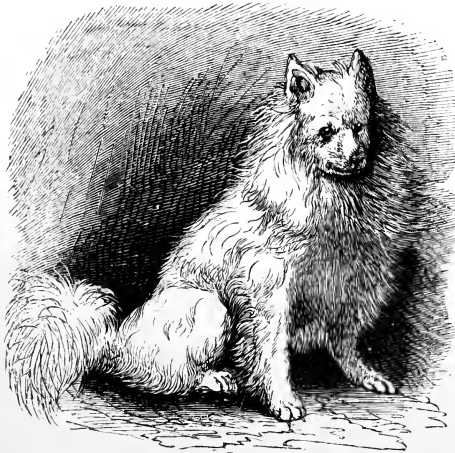

Esquimaux Dog.

ers familiar with the habits, appearance, and valuable properties of the Esquimaux dog; this species (*C. borealis*, Desm.) is probably the same as the Siberian dog. The Hare Indian dog (*C. lagopus*, Rich.), according to Sir John Richardson, is peculiar to the region of Mackenzie river and Great Bear lake; it is intermediate in size between the wolf and fox, has erect ears, bushy tail, and a general gray color, with white and black markings; the hair is long, and at its base, as in all arctic dogs, is a thick wool; it is about 14 in. high, and is used for hunting and not for draught; it is



Newfoundland Dog.

playful and affectionate, though not very docile. In the Hudson Bay territory, in Canada, and in the Lake Superior mineral district, there is a mongrel race of dogs which take the place

of horses during winter; they are hardy, easily managed, strong, bearing abuse, scanty food, and fatigue without murmur; they are invaluable to the hunter, Indian, half-breed, and traveller in these snow-clad regions; no particular breed is sought for, the only qualities valued being strength and endurance. The Newfoundland dog (*C. Terra Nova*, Smith) seems to be indigenous to America; it is longer than the Esquimaux dog, less compact, with a wider muzzle, drooping ears, and long hair disposed to curl; it is a handsome and powerful dog, very intelligent, trusty, and kind; the pure breed is almost semi-palmated, making them the best water dogs; crossed with the hound, they attain an enormous size; the general color is black, with some fulvous about the eyes, nose, throat, and joints, and white about the feet and end of the tail. Anecdotes of the sagacity of this well known breed are innumerable. The Nootka dog (*C. laniger*, Smith) is noted for its thick and matted fur, which the natives mix with wool and make into garments; the describer of this species

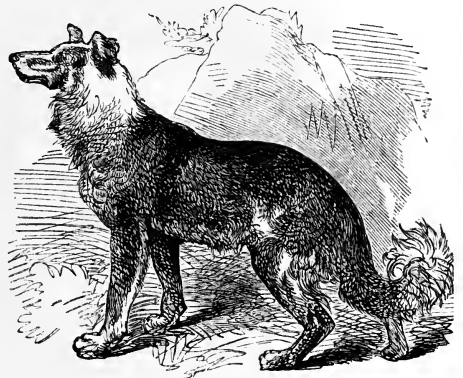

Shepherd's Dog.

thinks it indicates that the Esquimaux and Newfoundland races were derived from Asiatic originals, perhaps from the dog of Siberia. At the head of the list of the domestic canines of temperate Europe stands the shepherd's dog (*C. domesticus*, Linn.), still with the wolf-like stature, head, and hair; its appearance is rather unpromising; its shaggy hair is generally varied black and gray, the ears are short and erect, and the tail is bushy and curved; having been trained from time immemorial to the care of flocks, its peculiar faculties seem to be instinctive, and its sagacity, fidelity, and courage are not excelled by any species of dog; the height is not quite 2 ft., but the form is very muscular. This breed is confined to temperate and southern Europe. The true shepherd's dog attends the flocks, keeps them together, and protects them from violence. A variety called the drover's dog, somewhat larger and more rugged, is of great assistance in driving sheep and cattle to market. The great wolf

dog (*C. Pomeranus*? Linn.) has all the sagacity of the shepherd's dog, with a strength which enables him to resist successfully the attack of a wolf; it is large, whitish clouded with brown, with pointed nose, erect ears, and long silky hair; it is most common in southern Europe. The Alpine or St. Bernard dog is universally known; the old race resembled the Newfoundland dog, but the present dogs are short-haired, with very broad feet, and generally of a fawn color; their bark is uncommonly loud and deep. They are trained to carry food, wine, and warm coverings, attached to their bodies and necks; they depart in the morning, after violent snow storms, in search of lost travellers, and are followed by the monks. Many lives have been saved through their instrumentality; but now that the roads are better and more easily followed, and the inhabitants in the upper valleys more numerous, their services are less frequently called for. In the subdivision of the watch dogs of F. Cuvier are found some of the largest canines, and especially the fierce races mentioned by



St. Bernard Dog.

ancient authors; they have short hair and a wide muzzle, but in their skulls they resemble the wolf; the typical color is rufous, which is more or less mixed with black and white; occupying the northern temperate zone, they are probably descended from the lyciscan dogs, mixed toward the south with the mastiff race. They are less docile and sagacious than the former groups, but more watchful and noisy, and have considerable courage, and are therefore generally kept by the humbler classes to protect their farms; from this cause they are greatly crossed, and are doubtless the progenitors of the mongrel races of western Europe; from their moderate powers of smelling they are of little use in hunting. The Suliot dog (*C. Suillus*, Gmel.), sometimes called boar hound in Germany, is one of the largest and fiercest breeds; it is sometimes nearly 4 ft. high at the shoulder. Resembling this is the Danish dog (*C. glaucus*, Smith), but smoother, with shorter ears, and of a slaty blue color. The matin dog (*C. lanarius*, Linn.) has the

head elongated and the forehead flat, the ears pendulous at the tips, the hair rugged, of a yellowish fawn color with blackish rays; the height is about 2 ft.; being bold, strong, and active, it is valuable for a house and sheep dog. The Poe dog (*C. Pacificus*, Smith) seems to be indigenous to the South sea islands, and once was very abundant in the Hawaiian group; the muzzle is pointed, the ears erect, the back long, the limbs crooked, and the hair smooth and tan-colored; its food is vegetable, with a little fish, and it is much esteemed by the natives as an article of diet; the aboriginal race is now lost, from mixture with the imported dogs of Europe. The dogs of Patagonia are as large as fox hounds, and wolf-like in appearance; those of Tierra del Fuego are smaller, resembling a cross between the fox, shepherd's dog, and terrier. Their dogs are of great value to the natives of these regions. In France and several other countries, especially Holland, dogs are frequently employed as draught animals, and in Kamtchatka and Greenland almost exclusively for the same purpose.—Cuvier has asserted that the dog was perhaps necessary for the establishment of human society; though this may not be apparent in the most highly civilized communities, a moment's reflection will convince us that barbarous nations owe much of their elevation above the brute to the possession of the dog. That man has been able to make such extensive use of this animal must depend on innate qualities in the races, as, for instance, keenness of scent and the desire to chase, in the hound; the impulse to seek objects, in the spaniel and pointer; the tendency to watch and guard in the shepherd's dog and mastiff. The activity of their brain is shown by their proneness to dream. It is said that the ancients were fond of the flesh of dogs; it is well known that the Polynesians, Chinese, and American Indians consider it a great delicacy; when fed principally on vegetable food, it is palatable and nutritious.—The monuments of Egypt show that dogs, like men, were as distinct in their races thousands of years ago as now; and it becomes interesting to inquire if there are fossil dogs. Fossil canines have certainly been found, but these have been referred without examination as a matter of course to wolves, foxes, and jackals, and not to dogs; they are chiefly met with in the pliocene caves, in the drift, and in the alluvium. The fact has been already mentioned that it is very difficult to distinguish the different species of *canidæ* by their skeletons, except by the size of the bones. The domestic dogs have the last tubercular tooth wider than that of the wolf, and the teeth of many of the cave dogs differ from those of the domestic races only in being larger. Dr. Lund discovered fossil dogs larger than any now living in the caves of Brazil, associated with an extinct monkey; a similar association has been found in a stratum of marl, under compact limestone, in the Pyrenees. Dr. Schmerling has described several

fossils of the true dog, evidently belonging to two distinct varieties, differing in size from those of the wolf and fox found in the same locality. Cuvier says of the bones of a fossil *canis* from the cave of Gailenreuth, that they resemble those of the dog more than the wolf, yet he does not positively declare them to belong to the former. Marcel de Serres has described two species of dogs found in a marine tertiary limestone, one resembling the pointer, the other much smaller. The frontal elevation in the skull of the dog is greater than that of the wolf, and the skull of a small canine with this character strongly marked, from a bone cave in England, was pronounced by Mr. Clift that of a small bulldog or a large pug. Distinct traces of at least four types of dogs have been found in a fossil state, the Canary dog, the pointer, the hound, and the bulldog, with a smaller one classed by Schermerling with the turnspit; and as many of these are known to be hybrids, the list must probably be further enlarged. The certain antiquity of these bones, whether they have been referred to the proper race of dogs or not, is sufficient to destroy the claims of the wolf, jackal, or fox to the exclusive paternity of the domestic dogs. As there are undoubted wild canines which are true dogs, there is no improbability that some of these fossil remains may have belonged to such prior to their subjugation and domestication by man; and there is no more necessity of referring the fossil canines to a single species than the domesticated ones. The size of the fossil dogs is no greater than that of some living races mentioned in the text.—Those desirous of pursuing the subject of dogs more fully are referred to the writings of Buffon, Frédéric Cuvier, and Col. Hamilton Smith. See also BEAGLE, BLOODHOUND, BULLDOG, GREYHOUND, HOUND, MASTIFF, POINTER, SPANIEL, and TERRIER.

**DOG DAYS** (Lat. *dies caniculares*), among the ancients, the period of greatest heat in summer, so named because in the latitudes of the Mediterranean this period nearly corresponded with that in which the dog star rose at the same time with the sun. To this conjunction all antiquity, and all the later followers of judicial astrology, ascribed a malignant influence. The heliacal rising of the dog star is a very indefinite phenomenon; its precise dates cannot be determined, and owing to the precession of the equinoxes it does not now occur till about Aug. 10, when the greatest heat of the season is often over. So uncertain is the time that the ancients indiscriminately ascribe the evil influence to Sirius and Procyon (the largest stars respectively of Canis Major and Minor), though there is several days' difference in their heliacal risings. The modern almanac makers sometimes reckon the dog days from July 24 to Aug. 24, and sometimes from July 3 to Aug. 11.

**DOGE** (Lat. *dux*, a leader), the title of the elective chief magistrate in the republics of

Venice and Genoa. The dignity or office was called *dogato*. The doges of Venice were elected for life. The first of them was called to the dignity in the year 697, when Venice had scarcely risen to the importance of a city, and he and his successors ruled it as sovereigns, with nearly absolute power. But when the state grew mightier both on land and sea, through commerce and conquests, its nobles continually strove to check the power and influence of their elective head, and the government became more and more oligarchical, its form more and more republican, the dogate a magistracy, and finally a mere title. A change in the constitution toward the end of the 12th century put the whole legislative power into the hands of the council of 470; this elected the executive council of 6 and the 60 *pregadi*, and the doge was elected by 12 electors, chosen by 24 members of the great council. The first chief magistrate thus elected was Sebastiano Ziani (1173), who, in order to make his dignity, now stripped of every power, at least popular, distributed money among the people at his installation; an act adopted by his successors as one of the ceremonies of inauguration. Another ceremony introduced by the same doge was that of marrying the sea by a ring thrown into the waves of the Adriatic, which emblem of power over the mighty element was bestowed upon him with many other marks of dignity by Pope Alexander III., whom he supported in his long and bloody struggle against the emperor of Germany, Frederick Barbarossa. A new council of 40, established in 1179, and vested with supreme judicial power, also served to circumscribe the prerogatives of the doge. It was in vain that many a chief magistrate covered his office and the state with glory; in vain that Enrico Dandolo, the nearly blind nonogenarian, led the victorious fleet of the fourth crusade to Constantinople (1202-'4), that he was, at both attacks, among the first to storm it, that he refused the conquered imperial crown; the nobility were incessantly bent on the humiliation of the so-called chief of the state, which was completed in the second half of the 13th century, and at the beginning of the next, by the new and last election law, the most complicated instrument of indirect exercise of sovereignty that has ever been framed, by the introduction under Gradenigo of the hereditary nobility and its golden book, and the establishment of the terrible council of ten, supreme in power, irresponsible, and judges of the doge himself. Stripped of nearly all his prerogatives, the power of the doge was confined to the command of the army and the opportunity of profiting by the frequent strifes and contentions of the different councils and classes; and the office became so burdensome that a law had to be enacted (1339) prohibiting any one from laying it down, and that in 1367 Contarini had to be forced to accept it. The doge received ambassadors, but could give them no answer of his own, and their letters he

opened in the presence of the senate; money was struck in his name, but without his stamp or arms. He was not allowed to leave the city, to announce his accession to any but princes of Italy, to accept presents, to possess estates in foreign countries, or to marry his daughters to foreigners. His children and relatives were excluded from every important office. He was surrounded by spies, fined for every transgression, and his conduct scrutinized after his death by a tribunal of three inquisitors and five correctors. The office was destroyed with the state in 1797, by the French, under Bonaparte.—In Genoa, the first doge was elected for life in 1339, after the victory of the popular party over that of the nobility, and voluntarily shared his power with a council of state consisting of twelve members, six from the nobility and six from the people. But during the long internal and external contentions of this republic, the dogate was often modified, and sometimes even abolished. Andrea Doria, the great admiral, and the deliverer of the republic from the yoke of the French in 1528, reorganized it, and his constitution remained, but slightly altered, till the French conquest (1797). According to it, the doge, who must be a noble, and 50 years of age, was elected for two years; he presided in the two legislative councils, of 300 and of 100; had the right of proposing and vetoing laws; exercised the executive power with 12 secret councillors; and resided in the palace of the republic. The ceremonies and restrictions connected with his election and dignity were similar to those in Venice. Napoleon, having founded the republic of Liguria, restored this ancient dignity (1802), and abolished both when elected emperor of the French (1804).

**DOG FISH**, a cartilaginous plagiostome, of the family *squalidæ* or sharks, and the genus *acanthias* (Risso), of the class selachians of Agassiz. This genus is characterized by two dorsal fins with a strong spine before each; the first dorsal is behind the line of pectorals, the second between the ventral and caudal spaces; no anal fin; temporal orifices large; skin rough in one direction, the scales heart-shaped with a central spine directed backward; teeth in several rows, sharp and cutting, with the points directed backward and outward. The common dog fish (*A. Americanus*, Storer) has the upper part of the body of a slate color, deepest on the head and lightest on the sides, and white below; just under the anterior portion of the lateral line is a row of circular white spots, and a few similar ones are irregularly distributed on the back; the young are still more spotted; the length does not exceed 5 ft. The species is found from Davis strait to New Jersey. Dog fish in spring and autumn appear in large numbers in Massachusetts bay, and the residents of some towns on Cape Cod give up all other business at these times to fish for them; they are valuable for the oil from the livers, for the food of swine, and for the

polishing property of their skin. The weight varies from 8 to 25 lbs. They remain in shallow water three or four days, at which time they are easily caught with the hook; they

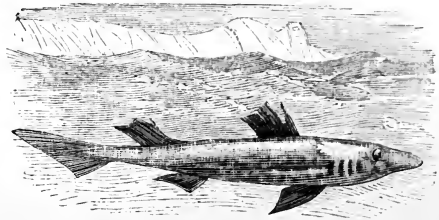

Dog Fish (*Acanthias Americana*).

feed on garbage, and may be called the scavengers of the sea. The young are brought forth alive, and are often seen swimming about with the yolk bag attached. In the British provinces they are dried, and in the winter given to pigs, which thrive well upon them; the refuse parts are used for manure. The dog fish (*acanthias*) of Europe is a different species; its flesh is eaten in Scotland. Along the east coast of England it is called the bone dog; it troubles the fishermen by cutting off their hooks; according to Mr. Couch, it bends itself into a bow for the purpose of using its spines, and then by a sudden motion causes them to spring asunder in opposite directions. Three species of *scyllum* (Cuv.), of a reddish brown color with numerous spots, are called dog fish in Europe.—There is another shark (*mustelus canis*, Mitch.), also viviparous, called dog fish. In this genus the teeth are blunt, forming a close pavement in each jaw; the first dorsal is in advance of the ventrals; there are no spines; the body is cylindrical and elongated, of a uniform slate color on the back and sides, and dusky white below; the head is flat between the eyes. This shark grows to a length of 5 ft., and is very common in Long Island sound, where it is taken in nets spread for other fish; from the form of the teeth it is probable that the food consists principally of crustacea and mollusks; it is not common on the coast of Massachusetts, but is abundant on the shores of New Jersey, where it is very troublesome to the fishermen by stealing their baits and driving away other more edible species; its flesh, though occasionally eaten, is coarse, rank, and unpalatable. In Europe the species of this genus are often called hound fish; the *M. lævis* (Cuv.) is called the smooth hound from the softness of the skin, and ray-mouthed dog fish from the peculiar conformation of the teeth.—The dog fish of the great lakes of North America is a soft-rayed bony fish, generally placed in the herring family, and the genus *amia* (Linn.).

**DOG GRASS.** See **COUCH GRASS.**

**DOG STAR**, or **SIRIUS**, the brightest star in the heavens, belonging to the constellation Canis Major. Sir J. Herschel estimates its light as

exceeding more than twofold that of Canopus, the second star in brilliancy, and more than fourfold that of Alpha Centauri, the third, whose light the same astronomer takes as the standard for first magnitude stars. But the variable Eta Argûs, shining now as a sixth magnitude star, nearly equalled Sirius in lustre 30 years ago. Sirius was known to the ancients as a red star, Ptolemy describing it as *ὑποκίρρος*, reddish yellow, and Seneca speaking of it as ruddier even than Mars. Its light at present is perfectly white. Examined with the spectroscope by Rutherford and Huggins, it shows a spectrum crossed by a multitude of fine lines, and by four very strong lines. The four lines are identified with the hydrogen lines. Their strength and breadth seem to imply that the star is surrounded by an extensive atmosphere of hydrogen, existing close to the photosphere, at a very great pressure. From a measurement of the position of the F line of hydrogen, which appears slightly displaced toward the red end of the spectrum, Huggins has inferred that the star is receding from us at the rate of about 29 miles a second, or, taking into account the sun's own motion, at the rate of 26 miles a second in space. Lately, however, he has seen reason to believe that this estimate of the velocity is too high. The annual parallax of Sirius has been estimated at 0.150" by Henderson and Maclear, and at 0.250" by Cleveland Abbé. If we assume 0.2" as the value, the distance of the star exceeds about a million times the distance of the sun. From the observed apparent motion of the star upon the celestial sphere, it follows, assuming this estimate, that it is travelling athwart the direction of the line of sight at the rate of about 15 miles a second. Combining this motion with Huggins's estimate of the motion of recession, it follows that it is actually moving through space at the rate of 33 miles a second. Certain peculiarities of the proper motion of Sirius have led astronomers to the belief that the star has a companion, not equally bright, but large enough to give Sirius an appreciable motion of circulation around their common centre of gravity.

**DOGWOOD** (*cornus*, Linn.), small deciduous trees or shrubs of the order *cornaceæ*, natives of Europe, Asia, and North America, of which there are several species. *C. alternifolia* (Linn.), the alternate-leaved dogwood, is indigenous to North America, and is found in shady woods or by river banks in every latitude. It frequently attains a height of 15 to 20 ft. The leaves are alternate, ovate, and acute; flowers white, May to July; fruit dark blue, ripening in October. Of all the species of *cornus*, the flowering dogwood (*C. florida*, Linn.) is the most beautiful, and in its native soil under favorable circumstances attains a height of 30 to 35 ft. The specific name *florida* was bestowed because of the profusion of its flowers. Specific characters: branches shining; leaves ovate, acuminate, pale beneath; flowers

umbellate, protruded after the leaves; leaves of involucre large, roundish, retuse, white and very showy; drupes ovate and bright red. It is found as far northward as New Hamp-



Alternate-leaved Dogwood (*Cornus alternifolia*).

shire, but particularly abounds in New Jersey, Pennsylvania, Maryland, and Virginia, where the soil is moist; in Florida and the Carolinas it is found only in swamps; in Ohio, Kentucky, and Tennessee, it is not found in the forests except where the soil is gravelly. It was first described in Ray's *Historia Plantarum* (1686-1704), and afterward by Catesby in his "Natural History of Carolina." The wood is hard, fine-grained, and susceptible of a high polish. It



Flowering Dogwood (*Cornus florida*).

enters into the construction of many articles of ornament and utility, such as the handles of mallets, toys, harrow teeth, hames for horse collars, and the shoeing of sleds. The inner

bark is very bitter, and has medicinal properties similar to Peruvian bark; the surgeons of the confederate army found it their best dependence in the absence of quinia. It is said to contain a principle, cornine, similar to quinia; the cornine used by the eclectics is a resinoid precipitate resulting from treating a strong tincture with water; it contains much tannic acid. The bark may be used instead of galls in the manufacture of ink; the Indians obtained a scarlet dye from the bark of the roots. The flowering dogwood is frequently cultivated as an ornamental tree, its large flowers, which rival the whiteness of snow, affording a pleasing contrast with the deep green of the surrounding foliage.—The name dogwood is improperly given in some parts of the United States to the *rhus venenata*, a species of poisonous sumach.

**DOL**, a town of France, in the department of Ille-et-Vilaine, 13 m. S. E. of St. Malo; pop. in 1866, 4,230. It contains a fine cathedral, and possesses considerable historical interest. During the middle ages it was frequently besieged, and passed into many different hands. In 1793 it was garrisoned by the Vendéans, and successfully resisted an attack of the republican troops. The old fortifications of the town are still standing.

**DOLABELLA**, **Publius Cornelius**, a Roman general, born about 70 B. C., died in 43. He was noted for his profligacy, and is said to have committed several capital crimes in his youth which but for Cicero would have cost him his life. About 50 he put away his wife Fabia, and, notwithstanding his debauched character and the opposition of Cicero, married Tullia, the daughter of the latter. In the next year the urgent demands of his creditors compelled him to leave Rome, and he sought refuge in the camp of Cæsar, to the great sorrow of Cicero. After the battle of Pharsalia, in which he took part, he returned to Rome and became a tribune. His acts led to bloody struggles between the two parties, which did not cease until Cæsar's arrival in the autumn. Cæsar did not think it prudent to punish him, but to get him out of the city took him with him to Africa and in his campaign against the sons of Pompey in Spain. He promised Dolabella the consulship in 44, but Antony opposed him. The senate was to decide on the opposition on March 15, when Cæsar's assassination changed everything. Dolabella at once seized the consular fasces, approved of the murder, caused Cæsar's altar to be thrown down, and crucified or threw from the Tarpeian rock many who were anxious to pay Cæsar divine honors. His conduct pleased the republican party, and he was awarded the province of Syria. On his way thither he committed such atrocious crimes that he was outlawed by the senate and declared a public enemy. Cassius marched against him, and Dolabella, to avoid falling into his hands, was killed by one of his own soldiers by his own orders.

**DOLCI**, or **Dolee**, **Carlo**, or **Carlino**, an Italian painter, born in Florence, May 25, 1616, died there, Jan. 17, 1686. His father, grandfather, and uncle were all painters, and he was placed at the age of nine with Jacopo Vignali. Under Vignali's tuition Carlo's genius developed with such remarkable rapidity that after a few years he attempted successfully a full-length figure of St. John. He next produced a figure of his mother, and the delicacy and tenderness which marked these early productions attracted much attention, and procured for him employment at home and abroad. He devoted himself almost exclusively to sacred subjects. His works are deficient in imaginative genius, but they are all distinguished by agreeable coloring, a remarkable relief produced by his skilful management of chiaroscuro, a singular delicacy of composition, and a finish in which he approached almost the consummate patience and industry of the great Dutch masters. The sameness of expression in most of his pictures facilitates copies and imitations, which abound all over Europe. He excelled most in small pictures, and the themes in which he was most successful are borrowed from the New Testament. Among his best works are the "St. Anthony" in the Florentine gallery, the "St. Sebastian" in the palazzo Corsini, the "Four Evangelists" in the palazzo Ricardi at Florence, "Christ Breaking the Bread" in the marquis of Exeter's collection at Burleigh, and "Herodias with the Head of John the Baptist" and "St. Cecilia, or the Organ Player," at Dresden. Another of his chief productions, "Christ on the Mount of Olives," belongs to the collections of the Louvre in Paris.—**AGNESE**, one of his daughters, who married a merchant named Carlo Baci, was one of his best pupils, and the most successful copyist of his works.

**DÔLE** (anc. *Dola*), a town of France, department of the Jura, 28 m. S. E. of Dijon; pop. in 1866, 11,093. It is situated on the slope and at the foot of a hill on the right bank of the river Doubs, near the canal that joins the Rhône and the Rhine. The railway from Dijon to Besançon, which passes the town, gives it some importance as a place of transit between Paris and Switzerland. It has a college, a public library of 40,000 volumes, two hospitals, and the ruins of a castle built in the 12th century. The principal building is the cathedral of Notre Dame. There are manufactures of hosiery, pottery, and chemicals, iron-smelting furnaces, flour mills, tile works, tanneries, and quarries. Dôle is of great antiquity, having been a considerable town under the Romans, and is situated on the old road leading from Lyons to the Rhine. Some remains of this work, as well as of an ancient aqueduct and theatre, are still to be seen. It was for a time the capital of Franche-Comté and the seat of a parliament. After having been taken once or twice previously, it was captured and dismantled by the French in 1674. During the Franco-German war it was for a time the

headquarters of Garibaldi. It was occupied by the Germans Nov. 14, 1870, and again Jan. 21, 1871.

**DOLET, Étienne**, a French scholar and printer, born in Orleans in 1509, burned as a heretic in Paris, Aug. 3, 1546. He was fond of classical studies, and one of the especial admirers of Cicero, and warmly defended this predilection against the sarcasms of Erasmus. He was rash and impetuous, which made him many enemies, who lost no opportunity of persecuting him. Having been often accused of cherishing heretical sentiments, he was at last adjudged an atheist by an ecclesiastical court at Paris, in consequence of an expression which he used in his translation of the *Aviochus* of Plato, which was not to be found in the original; and for this he was condemned.

**DOLGORUKI**, a princely family of Russia. **GRIGORI** in 1608-'10 gallantly defended a monastery near Moscow against the Polish forces under Sapieha. In 1624 **MARIA** married Czar Michael, founder of that branch of the house of Romanoff which still retains the throne of Russia; but she died four months later. **YAKOV**, born in 1639, was liberally educated, and entered the civil service in 1676, and was sent as ambassador to the western powers in 1687. He entered the army in 1695, and distinguished himself in the campaign against the Turks, especially at the siege of Azov. In the war with Sweden he was captured (1700) and kept a prisoner at Stockholm for ten years. After his release Peter made him a senator and confided to him the most important affairs of state. He died in St. Petersburg in 1720. **YURI** (George), a general under Alexis and Feodor, was killed in the revolt of the Strelitzes (1682), while fighting for the claim of Peter to the throne. **МИХАИЛ**, his son, who had been a minister of Feodor, perished with his father. **IVAN** was the friend of Peter II., to whom his sister Catharine was betrothed; but the czar died before the day set for the marriage (1730), and Ivan made a vain attempt to have him name Catharine as his successor. He then aided in raising Anna to the throne; but through the influence of her favorite, Biron, he and all his family were exiled. Afterward recalled from exile, he was accused of conspiracy, and executed at Novgorod (1739). Other members of the family were exiled. **VASIL**, born in 1667, entered the army at an early age, and in 1715 had risen to the rank of major general. Peter the Great sent him on a special mission to Poland, and he was afterward minister to France, to Germany, and to Holland. In 1718, for suspected complicity with the czarevitch Alexis, he was banished; but Catharine recalled him in 1726, and made him general-in-chief, and commander of the army in the war against Persia. In 1728 Peter II. appointed him field marshal, and the next year he became president of the council of war. In 1739 he was imprisoned on some trivial pretext; but when Elizabeth came

to the throne, two years later, she released him and restored his marshalship. He died in 1746. **VASIL**, nephew of the preceding, commander-in-chief of the army of Catharine II., conquered the Crimea in a short campaign in 1771, and received from the empress the surname of Krimskoi. **VLADIMIR** resided for 25 years as minister of Catharine II. at the court of Frederick the Great, whose friendship he gained. **МИХАИЛ**, born in 1766, was aide-de-camp to Alexander, and served in the campaigns against France and in Moldavia in 1805-'6, and in Finland as lieutenant general in 1808, where he fell in battle. **IVAN**, born in 1764, spent most of his life in the public service, but cultivated letters, and was a frequent contributor to current literature. He wrote many patriotic poems, and is especially noted for his epistles and satires. He died at Moscow in December, 1823. **VASIL** was minister of war from 1849 to 1856, and was then for some time minister to France. He died in 1868. **PETR**, born in Moscow about 1817, wrote several works, among which are: *Recueil de généalogies russes* (St. Petersburg, 1840-'41); *Notice sur les principales familles de la Russie* (Brussels, 1843), an English translation of which appeared in London in 1858; *Dictionnaire de la noblesse russe* (St. Petersburg, 1854-'7); *La vérité sur la Russie* (Paris, 1860), for which the Russian government banished him and confiscated his estates; and *La France sous le régime Bonapartiste* (Paris and London, 1864). He died in Bern in August, 1868. His *Mémoires* were published after his death in Basel, in two volumes (1869-'71).

**DOLLAR**, the monetary unit in the United States and several other countries, both of coined money and money of account. All values in the United States are expressed in dollars and cents, or hundredths. The term mill, for the  $\frac{1}{1000}$  of a dollar, is rarely employed. The dollar unit, as a money of account, was established by act of congress of April 2, 1792, and the same act provides for the coinage of a silver dollar "of the value of a Spanish milled dollar as the same is now current," and of half and quarter dollars in proportion. The silver dollar was first coined in 1794, weighing 416 grains, of which  $371\frac{1}{2}$  grains were pure silver, the fineness being 892.4 thousandths. The act of Jan. 18, 1837, reduces the standard weight to  $412\frac{1}{2}$  grains, but increases the fineness to 900 thousandths, the quantity of pure silver remaining  $371\frac{1}{2}$  grains as before, and the half and quarter dollars suffering proportional changes. By the act of Feb. 21, 1853, the half dollar was reduced in weight to 192 grains, and the quarter dollar in proportion, and these coins became a legal tender only for sums not exceeding \$5, while the dollar suffered no change in weight, and remained a legal tender for all sums. The act of March 3, 1849, directs a coinage of gold dollars. They were issued the same year, weighing  $25\frac{8}{10}$  grains,  $\frac{9}{10}$  fine,  $23\frac{2}{10}$  grains be-



ing pure gold. By the act of Feb. 21, 1853, the three-dollar piece of gold was authorized,  $\frac{9}{10}$  fine and weighing 77.4 grains. The act of Feb. 12, 1873, known as the "coinage act of 1873," makes the gold dollar the unit of value, but effects no change in the weight or fineness of that coin or of the three-dollar piece, which continues to be a legal tender for all sums. By this act, however, a "trade dollar," weighing 420 grains, designed for the convenience of commerce with China and Japan, was substituted for the old silver dollar, while the weight of the half dollar was fixed at 12 grams, or 192.9 grains, half the weight of the five-franc piece of France and other European countries, the quarter dollar being proportional. The fineness of these coins is unchanged, but the silver dollar is no longer a legal tender for sums exceeding \$5. The number of coins of each kind produced at the mint and its branches, from their organization to June 30, 1872, is as follows:

Three-dollar pieces.....	390,971
One-dollar pieces (gold).....	19,015,642
One-dollar pieces (silver).....	8,045,583
Half-dollar pieces.....	199,630,571
Quarter-dollar pieces.....	87,536,274
Whole number of pieces.....	314,619,596

The value of the coinage is \$149,933,897.—The term dollar is of German origin. During the years 1517–26 the counts Schlick, under a right of mintage conferred by the emperor Sigismund in 1487 upon their house, caused to be struck a series of silver coins of 1 oz. weight, and worth about 113 cents of our money. These pieces were coined at Joachimsthal (Joachim's dale), a mining town of Bohemia, and came to be known in circulation as *Joachimsthaler*, and then for shortness *Thaler*; and this name for coins and money of account has been widely used in the German states ever since. Some German scholars, however, derive the term *Thaler* from *talent*, which in the middle ages designated a pound of gold. In Norway and Sweden we find the *daler*, and in Spain the *dalera*, the Spanish dollar which for centuries figured so conspicuously in the commerce of the world. It was the Spanish pillar dollar (called also the milled dollar from its milled edge) that was taken as the basis of the United States coinage and money of account. By the act of April 2, 1792, 371 $\frac{1}{2}$  grains of pure silver and 24 $\frac{3}{4}$  grains of pure gold were declared to be equivalent one to the other, and to the dollar of account. At that time, as now in Great Britain, 113 grains of pure gold were the equivalent of the pound sterling. The value of £1 in federal money, therefore, was \$4 56.5. Prior to this date, and during the confederation, the dollar of account, as compared with sterling currency, had been rated at 4s. 6d., which was an exaggerated valuation of the Spanish dollar; and in accordance with this valuation the congress of the confederation had established \$4 44.4 as the custom house value of the pound sterling. The effect of the

act of 1792 was really to reduce the value of our dollar of account, but apparently to increase the value of the pound sterling about 2 $\frac{1}{2}$  per cent. By the act of June 28, 1834, the weight of fine gold to the dollar was reduced from 24.75 to 23.20 grains; and on Jan. 18, 1837, it was fixed at 23.22 grains. Comparing this latter weight with the pound sterling of 113 grains, we find an apparent increase in the value of £1 to \$4 86.6, an advance of exactly 9 $\frac{1}{2}$  per cent. upon the old valuation of \$4 44.4. We have here the explanation of the practice of quoting sterling exchange at 9 $\frac{1}{2}$  per cent. premium when it is really at par. A much more intelligible method would be to state in dollars and cents the ruling rate per pound sterling for bills on London; *e. g.*: \$4 84, \$4 87, \$4 90, &c.—Spanish dollars were chiefly coined in the Spanish American colonies. The best known variety was the pillar dollar, so called from the two pillars on its reverse, representing the "Pillars of Hercules," the ancient name of the opposite promontories at the straits of Gibraltar. The rude imitation of these pillars in writing, connecting them by a scroll, is said to have been the origin of the dollar mark (\$). Another explanation is that, as the dollar consisted of 8 *reals* (8 R. being stamped upon it), the mark was designed to stand for the "piece of eight," as the dollar was commonly called, the two vertical lines being employed to distinguish it from the figure 8. The Spanish American dollars ceased to be coined when the colonies became independent, and since 1822 their place in commerce has been supplied by the dollars of Mexico, Bolivia, and Peru. (See COINS.)

**DOLLART BAY**, or **The Dollart**, an arm of the German ocean, about 10 m. in length from N. to S., and 7 m. in breadth. It lies between the Prussian province of Hanover and the Netherlands, at the mouth of the river Ems. It is supposed to have been formed by an inundation in 1277, and another in 1287, which destroyed 3 towns and nearly 40 villages, with thousands of human beings and cattle. The sea has since receded in some measure, and several thousand acres of land have been recovered.

**DOLLIER DE CASSON**, François, a French monk and explorer, born about 1620, died in Montreal, Canada, Sept. 25, 1701. He entered the army and became a captain in Turenne's cavalry. His courage was equal to his strength, which is said to have been so great that he could hold at arm's length a man seated on each hand. Having entered the congregation of St. Sulpice, he went to Canada about 1655. In 1670 he explored Lake Erie and drew up the first map of its whole basin. He was for many years superior of the Sulpicians at Montreal, and wrote a history of that settlement, which was published by the Montreal historical society in 1869.

**DÖLLINGER**. I. Ignaz, a German physiologist, born in Bamberg, May 24, 1770, died in Munich, Jan. 14, 1841. He studied medicine in the

universities of Würzburg, Vienna, and Pavia, and in 1794 was appointed professor of medicine at Bamberg; but the university having been dissolved, he became professor at Würzburg, and in 1823 at Landshut, removing with that university in 1826 to Munich, where he remained until his death. His position in the history of science is mainly due to his researches in comparative anatomy and physiology. His principal works are: *Naturlehre des menschlichen Organismus* (1805), *Grundzüge der Physiologie* (1835), *Entwickelungsgeschichte des Gehirns* (1814), and *Grundzüge der Entwicklung des Zell-, Knochen- und Blutsystems* (1842). He invented an improvement of the microscope. **II. Johann Joseph Ignaz**, a German theologian, son of the preceding, born in Bamberg, Feb. 23, 1799. He was ordained priest in 1822, and became chaplain of Marktscheinfeld in the diocese of Bamberg. His literary productions obtained for him at the age of 24 a chair of church history and polity at the lyceum of Aschaffenburg. Three years later he was appointed professor at the university of Munich. He became one of the most influential men in the ecclesiastical affairs of Bavaria, and was soon identified with the policy of Abel's ministry. His literary labors during this period were chiefly directed to the claims of Protestantism, and he accumulated in his works everything unfavorable to it. He wrote *Kirchengeschichte von der Zeit der Reformation bis zur neuern Zeit*, in continuation of Hortic's *Handbuch der christlichen Kirchengeschichte*, of which he prepared a new edition (Ratisbon, 1833), and commenced a *Handbuch der Kirchengeschichte* on a very extensive plan, but completed only two volumes. His *Lehrbuch der Kirchengeschichte* (1836-'8) is also incomplete, as it leaps over the whole internal history of the middle ages, and is brought to a close at the time of the reformation. He undertook a third work, *Christenthum und Kirche zur Zeit ihrer Grundlegung*, for which he wrote a prolegomena entitled *Heidenthum und Judenthum* (1857), and of which the first volume appeared in 1860. In these works he sharply criticised every opposition to papal authority and received creeds; but he was equally sharp in his moral criticisms of the popes. With the fall of Abel's ministry in 1847 he lost his professorship, but he still remained provost of the collegiate church of St. Cajetan in Munich. In the following year he was elected to the parliament at Frankfort, where he represented in all respects the interests of the Catholic hierarchy. He was reinstated in his chair in 1849, but failed to regain his former influence in government circles. His observation of the movements of the ultramontanists weakened his confidence in his party, and in 1861 he gave a series of popular lectures on the prospects of the continuance of the secular power of the pope, which were appended to his *Kirche und Kirchen, Papsthum und Kirchenstaat* (Munich, 1861). This work roused the

suspicious of the ultramontanists; it gives a synopsis and critique of the Protestant beliefs and sects, in a spirit of great moderation, and declares that Luther was the greatest man of his time. Döllinger called for a congress of learned men to discuss the subject of science and faith, the incompatibility of which had been declared in a recent work of Frohschammer. The meeting was held in September, 1863, and at its close he sent a telegram to the pope, saying, "On the question of the relation of science to ecclesiastical authority, the meeting has decided that the former should be subject to the latter." His *Papstfabeln des Mittelalters* (1863) awakened new suspicions; but in 1864 he joined several professors of theology in Munich in a public declaration of their firm orthodoxy, and of their opposition to Frohschammer and his tendency. But the Jesuits were not satisfied, and continued their attacks upon him in the *Civiltà Cattolica*. The result was that he became more estranged from the episcopacy, and sought his friends among the members of the ministry, who readily lent him their aid in thwarting some of the plans of his enemies. After the papal syllabus of 1864, the Jesuits began to discuss the necessity of having the infallibility of the pope formally announced as a doctrine of the church. Döllinger opposed this proposition, and published in the Augsburg *Allgemeine Zeitung* a series of anonymous articles, which appeared in a separate form under the title of *Papst und Concil*, by Janus (1869). This work was translated into English, French, and Italian, and passed rapidly through several editions; but Döllinger has only indirectly acknowledged himself the author of it. Its object is to show by means of authenticated documents that the papal power was based on fictions and frauds and on great ignorance of historical facts; but it does not relinquish the doctrines of the primacy of the pope and of the infallibility of the church. Döllinger was appointed in 1868 councillor of state for life, and as such he voted against the liberal bill for education. When the doctrine of infallibility was adopted by the council of the Vatican, July, 1870, Döllinger was asked by the archbishop to explain his previous attitude, and to announce his willingness to submit to the decision of the council. He refused to do so, and offered to state his reasons and prove their validity before an ecclesiastical assembly. The organs of the liberal party praised his action, and nearly all the Catholic professors at the university of Munich signed an address of congratulation and sympathy. From the opposition thus excited sprang up the so-called "Old Catholic" movement in Bavaria, that designation (which had been assumed about ten years before by an organization in Baden) being adopted by 12,000 signers of a petition to the king against the teaching of the doctrine. Döllinger received also congratulatory addresses from several cities in Germany and Austria, and his

name became as eminent among anti-Catholics as it had been among ultramontanists. The archbishop announced that all Catholics who continued to attend Döllinger's lectures were rendering themselves liable to excommunication, and issued a pastoral letter to the signers of the address, in which he vindicated the position of the church, and stigmatized Döllinger and his adherents as rebels and schismatics. The Catholic clergymen of Munich published at the same time a declaration of their implicit faith in the new doctrine. Other clergymen in different parts of the country made declarations to the same effect, and Döllinger found himself deserted by a large majority of the several generations of theologians who had been his pupils, while the archbishop issued against him the great excommunication. Döllinger discontinued his clerical functions, although as provost of St. Cajetan, and as superior court chaplain, the court churches were at his command. With 30 of his partisans he published a declaration, reiterating their intention of adhering to the old doctrines of the church, and of rejecting every new doctrine, but declaring also that the doctrine of infallibility was based on forgeries, that it was making the pope a counterpart of the sultan of Turkey, that it was perilous to the church and society, and that the assertions to the contrary by some bishops were of no value, because others, like Archbishop Manning of Westminster, were already extending the application of the doctrine to political matters. In July, 1870, Döllinger was elected *rector magnificus* of the university of Munich, and confirmed as such by the king. In February, 1872, he called a conference at Munich for the purpose of discussing a possible reunion of all the different Christian churches. After considerable debate they adjourned till Sept. 20, when a large Old Catholic congress met at Cologne. Döllinger's principal works not before mentioned are: *Die Lehre von der Eucharistie in den ersten drei Jahrhunderten* (Mentz, 1826); *Mohammed's Religion* (Ratisbon, 1838); *Die Reformation, ihre innere Entwicklung und ihre Wirkungen im Umfange des lutherischen Bekenntnisses* (3 vols., 1846-'8); and *Hippolytus und Kallistus* (1853). Several of his works have been translated into English; that on Paganism and Judaism by N. Darnell ("The Gentile and the Jew, an Introduction to the History of Christianity," London, 1862), and that on "The Church and the Churches" by W. B. McCabe (London, 1862).

**DOLLOND. I. John**, an English optician, born in London, June 10, 1706, died there, Nov. 30, 1761. He was descended from a French refugee family, and was originally a silk weaver, but spent his evenings in studying various sciences and languages, and made a translation of the Greek Testament into Latin. His preference was for optics, and he went into partnership with his son as an optical instrument manufacturer at Spitalfields. He commenced

a series of experiments on the dispersion of light and other subjects connected with the improvement of telescopes and microscopes, the results of which were communicated to the royal society in a series of papers, which appeared in its "Transactions" during 1753, 1754, and 1758. For these he received the Copley medal, and in 1761 was elected a member of the society, and appointed optician to the king. He was the discoverer of the laws of the dispersion of light, and the inventor of the achromatic telescope. **II. Peter**, son of the preceding, born about 1730, died in 1820. Soon after entering into partnership with his father he removed his business from Spitalfields to St. Paul's churchyard, where he met with great success. He made several important improvements in optical instruments, and contributed some valuable papers to the "Transactions" of the royal society, one of which was a vindication of his father's claim to the discovery of the true theory of the refrangibility of light, which appeared in 1789.

**DOLMEN.** See CROMLECH.

**DOLOMIEU, Déodat Gui Sylvain Tancrède de Gratet de**, a French geologist, born at Dolomieu, Dauphiny, June 24, 1750, died at Châteauneuf, department of Saône-et-Loire, Nov. 26, 1801. When 18 years old he killed in a duel a knight of Malta, of which order he was himself a member. He was condemned to death, but the sentence was commuted to imprisonment for nine months, and in his dungeon he devoted himself to the natural sciences. On recovering his liberty he obtained a commission in the army, but did not relinquish his scientific investigations, of which the first fruits appeared in 1775 in his *Recherches sur la pesanteur des corps à différentes distances du centre de la terre*. Made a corresponding member of the academy of sciences, he abandoned the military profession and devoted the rest of his life to science. For a series of years he was engaged in exploring Portugal, Spain, Italy, and afterward Egypt, whither he went with Bonaparte's expedition. While on his return to Marseilles in 1799 he was seized by the Neapolitans, and through the enmity of the order of Malta detained in prison at Messina, where, amid extraordinary hardships, he wrote his *Traité de philosophie minéralogique*, and his *Mémoire sur l'espèce minérale*. He recovered his liberty March 15, 1801, with impaired health, and died soon afterward, while on a visit to his sister. The results of his researches are embodied in his contributions to the *Journal de Physique*, *Journal de l'Institut*, *Journal des Mines*, &c. More than 50 distinct memoirs, many of which contain valuable additions to the knowledge of geology and mineralogy, can thus be traced to his pen, besides his contributions to the *Dictionnaire minéralogique* and the *Nouvelle Encyclopédie*. His most interesting essays are: *Mémoires sur le tremblement de la terre de la Calabre*; *Voyage aux îles de Lipari*; *Mémoires sur les îles*

*Ponces, et Catalogue raisonné des produits de l'Etna*; and on the nature of leucite, anthracite, pyroxene, &c. The *Journal du dernier voyage du citoyen Dolomieu dans les Alpes* was published by Bruun-Neergaard at Paris in 1802.

**DOLOMITE**, a mineral species named in honor of the French geologist Dolomieu. It occurs crystallized in rhombohedral forms, and also as a rock of granular and crystalline structure. The mineral species includes several varieties, as brown spar, pearl spar, &c. Its hardness is 3.5-4; specific gravity, 2.85-2.92. The weight of a cubic foot of the rock is consequently about 180 lbs. Dolomite is a magnesian carbonate of lime, consisting of one equivalent of carbonate of magnesia and one of carbonate of lime, or, in 100 parts, 45.65 of the former and 54.35 of the latter. It is usually white, but is also found of various colors. It is largely developed as a metamorphic rock in the calciferous epoch of the Potsdam period of the Silurian age, and is found abundantly along the eastern part of the middle states, its range extending through the gold region of the southern states, northward, passing near Washington, Baltimore, and Philadelphia, thence crossing northern New Jersey, and to the south of the highlands across the Hudson, through western Massachusetts and Vermont into Canada. It also occurs at many localities to the eastward of this metamorphic range. It is very extensively developed in the Tyrolese mountains, Austria, and in various parts of Europe. A beautiful white dolomitic marble used by the ancient sculptors is found in the island of Tenedos, near the west coast of Asia Minor. A brown dolomite, the magnesian limestone of Tennant, occurs in the north of England in beds of considerable thickness, resting on the Newcastle coal formation. In the Isle of Man it is found in a limestone resting on graywacke, and it occurs in trap rock in Fifeshire. Columnar dolomite is found in metamorphic rocks in the Niagara group, in the upper Silurian formation in western New York, and in serpentine in Russia.—For agricultural purposes magnesian lime is not as highly valued as pure lime. It enters less largely into the composition of most cultivated plants, and is thought to render the soil less friable. For making mortar there is a difference of opinion, the European masons rejecting it, while it is popular in the United States. As a building stone, dolomite ranks among the best, as it is easily worked and very durable. It is obtained in large blocks of sound and uniform texture, with good grain for splitting, and unmixed with foreign matters. But different layers in the same quarry vary greatly in quality. The softness of the stone admits of its being easily sawn into ashlar and carved into ornamental mouldings. In England, dolomite has proved so durable and excellent, that a variety of it found at Bolsover moor was selected for the new houses of parliament. The choir of Southwell church, which was built of this variety of stone in the 12th century, was

found by the commissioners to be in so perfect a state that "the mouldings and carved enrichments were as sharp as when first executed." After describing other examples illustrating the durability of this rock, the commissioners say: "As far as our observations extend, in proportion as the stone employed in magnesian limestone buildings is crystalline, so does it appear to have resisted the decomposing effects of the atmosphere; a conclusion in accordance with the opinion of Professor Daniell, who has stated that, from the results of experiments, he is of opinion that 'the nearer the magnesian limestones approach to equivalent proportions of carbonate of lime and carbonate of magnesia, the more crystalline and better they are in every respect.'" The following analyses of some of the best of the American dolomites show how nearly they correspond in composition to the requisite of Professor Daniell:

MARBLE OF	ANALYZED BY	Carbonate of lime.	Carbonate of magnesia.
Hastings, N. Y.	J. W. Draper, M.D.	52.82	45.78
Sing Sing, " "	Lewis C. Beck, M.D.	53.24	45.89
Tuckahoe, " "	" "	61.75	38.25
Roxbury, Vt. ....	T. S. Hunt.....	53.90	44.04

**DOLPHIN** (*delphinus*, Cuv.), a carnivorous cetacean mammal, found in most of the seas of the world. The dolphins, as generally restricted, have a convex forehead, and a beak or snout armed with teeth, separated from the forehead by a well marked furrow; they do not acquire the dimensions of the whales, being rarely more than 9 ft. long. The body is fusiform in shape, without evident neck, and terminated by the horizontal tail common to all cetaceans; the head is not disproportionately large, and both jaws are toothed; there are two pectoral fins, and toward the middle of the back is a fold of the skin which may be called a dorsal fin; the eyes are small, with bare lids; the external opening of the ear is small; the tongue is thick, soft, and but slightly movable; the skin is naked and soft, covered only by a thick mucosity. The teeth are simple, conical, and numerous, varying in number even in individuals of the same species. The cranium is very small compared with the face, concave, and much elevated in front and arched behind; the snout is narrow and elongated from the prolongation of the maxillaries and intermaxillaries, which are not curved forward above; the upper jaw is a little shorter than the lower; the maxillaries extensively overlap the frontals; the tubercles which represent the nasal bones are above the intermaxillaries, resting on the frontals; the parietals are below the maxillaries, and quite on the side; the symphysis of the lower jaw is extensive, and the bone is light and hollow. The cervical vertebræ, seven in number, are very thin, and united; the dorsals are 13, with as many pairs of ribs, their articular processes becoming effaced by age, commencing posteriorly, and the trans-

verse being about as long as the spinous processes; the lumbar vertebræ are 18, with very long transverse and spinous processes; a sacral vertebræ can hardly be said to exist, as the pelvis consists of a rudimentary bone on each side suspended in the muscles; the caudal vertebræ are about 28, gradually decreasing in size, the transverse processes disappearing about the 16th, and the spinous about the 20th; exclusive of the cervicals, there are about 60 vertebræ in all; the V-shaped bones on the under surface of the bodies begin about the sixth caudal. The breast bone is composed of three bones, the first very wide, grooved in front, and usually pierced with a hole; the shoulder blade is fan-shaped, slightly concave; the clavicle is absent; the pectoral fin is composed of a very short humerus, with a large upper tuberosity, its lower extremity compressed antero-posteriorly, and uniting by a cartilaginous articulation on an irregular line with the bones of the forearm; the latter are almost rectangular, short and flat, the radius in front and the widest; the bones of the wrist, six or seven in number in two rows, form a flat pavement-like surface united by cartilage to the radius and ulna; there is a mere vestige of thumb, according to Cuvier, the index finger being the longest and having nine articulations with its metacarpal bone and phalanges, the third with seven, the fourth with four, and the fifth a mere tubercle. This anatomical description will answer generally for dolphins and porpoises, and the allied genera. Dolphins are among the swiftest of cetaceans, and their speed is owing to the strokes of the powerful tail; the pectoral fins serve merely to balance and guide the body, and to carry the young. The eye and ear are of the mammalian type; the nasal passages seem destined only for the expulsion of water from the mouth and for the introduction of air into the lungs, and are generally considered as not endowed with an average sense of smell; the taste must be very imperfect, and the sensibility of the naked skin low. The teeth are formed only for seizing and retaining prey, which is swallowed whole. Authors differ as to the stomach, some making it single, but most dividing it into three, four, or five compartments more or less complicated; the intestine is simple, 10 or 11 times as long as the body, and gradually diminishing from the stomach to the anus. The dolphin is not a fish, but an air-breathing mammal, warm-blooded, viviparous, and suckling its young. Though shaped like fishes, inhabiting the water exclusively, and moving in the same manner with them, it must come to the surface by means of its horizontal tail, and take in air through the single spiracle on the top of the head, which it can do when the mouth is full of water by means of the upward prolongation of the larynx into the nasal passages, and the shutting off of its cavity by muscular action from the mouth and œsophagus; the external opening of the spiracle is guarded

by a valve, which prevents the entrance of water when the animal plunges beneath the surface. The water taken into the mouth with the food can be made to pass out in a jet from the spiracle, by the closing of the pharynx, and the forcing of the liquid into the nose through the passage in which the larynx is elevated during respiration. Under the skin, in front of the nostrils, are two large cavities covered with muscles; into these the water is sent, and remains until the animal chooses to eject it; then closing a valve at their entrance, the water is sent forth by the contraction of the muscles. The dolphin family make a feeble moaning or plaintive noise, which has often been noticed when they have been stranded alive. The circulation is carried on as in other mammals; only, in order to enable them better to remain under water, there is a plexiform arrangement of the arteries within the chest and near the spine, which serve as reservoirs of pure blood during immersion; these do not communicate directly with veins, and their contents can be taken into the circulation as circumstances require. The reproductive organs are the same as in other mammals, and their functions are similarly performed; the testes are within the abdomen; the prostate gland is large, but the seminal vesicles are absent; the mammae are two, with the nipples concealed in a fold of skin, except during lactation, when they protrude on each side of the genital opening. The kidneys are made up of many small glands united. The brain is very wide, the hemispheres however covering only a portion of the cerebellum; the convolutions are numerous and complicated, but narrow; the olfactory lobes seem to be wanting; the cerebellum is well developed, with distinct median and lateral lobes. This great cerebral development affords some ground for the ancient belief in the superior intelligence of the dolphin. The history of this animal, sacred to Apollo, though enumbered with fabulous and superstitious accounts, doubtless contains much truth which whale-hunting moderns have not cared to examine.—As the dolphin family till recently included all ordinary cetaceans with small heads, the divisions which have since been made are very numerous, and no system of classification as yet offered can be called natural. Such only, therefore, as would not come more properly under other popular titles will be briefly alluded to. At the head of the list is the common dolphin (*D. delphis*, Linn.); this, from the shape of the beak, is vulgarly called the "goose of the sea;" it was the *hieros ichtyus* (sacred fish) of the ancients, the favorite of Apollo (whose most famous oracle bore its name), and the supposed benefactor of man; it is seen on very ancient coins and medals, and formed a conspicuous object on the coat of arms of the princes of France; from it was named the province of Dauphiny, which gave the title to the heir apparent to the French throne. It attains a length of

from 6 to 10 ft., and its proportions are admirably adapted for the speed which is its characteristic. It is dark on the back, grayish on the sides, and satiny white underneath. The

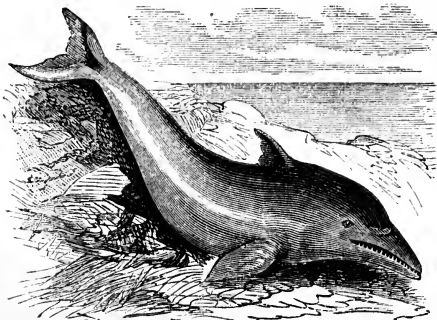

Common Dolphin (*Delphinus delphis*).

geographical range of this species embraces the seas of Europe, the Mediterranean, and the northern and temperate Atlantic; other species are found in the seas of America, Asia, and Africa. Vessels frequently meet them in large numbers, shooting under the bows, springing out of the water, and racing with their fellows; their speed is such that they easily outstrip the swiftest steamer. The dorsal fin is about 9 in. high, a little behind the middle of the back; the pectorals, about 2 ft. from the snout, are somewhat longer than the dorsal, narrow and rounded; the tail is crescent-shaped, with a notch in the middle, and about a foot wide; the jaws have from 32 to 47 teeth on each side, according to age, simple, conical, largest in the middle of the series. During rapid motion the tail is bent under the body, and then suddenly brought into a straight line. The dolphin lives principally upon fish, which it pursues even into the midst of the fishermen's nets. F. Cuvier thinks an examination of the habits of the dolphin will disclose a foundation in fact for the supposed intelligence of this

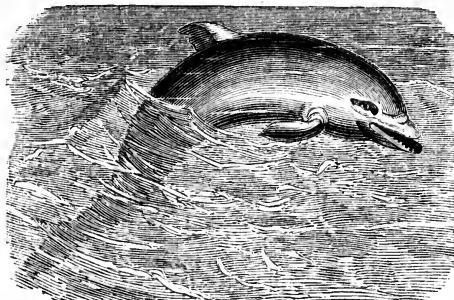

Bottle-nosed Dolphin (*Delphinus tursio*).

species. In former times the flesh of the dolphin was as much esteemed for food as it is now neglected; in the 16th century its price was so high that it was only seen on the tables of the rich; in the time of Dr. Caius, founder

of the college of that name at Cambridge, a dolphin was thought a worthy present for the duke of Norfolk, who in turn distributed it to his friends. In France the dolphin could be eaten during Lent without sin, all cetaceans being then considered fish. The meat is dark-colored, palatable and nutritious, and is now often eaten by seafaring men on long voyages. The *D. tursio* (Fabr.), the *nesarnak* of the Greenlanders, has a thick body, a flattened, short beak, obtuse teeth, a dorsal fin, and a blackish color, except a small part of the abdomen, which is whitish; it attains a size of 9 to 15 ft., has from 88 to 100 teeth, and inhabits the Atlantic from the shores of Europe to those of Greenland; it is less active than the common dolphin. Another name for it is the bottle-nosed dolphin or whale. Other dolphins are the lead-colored (*D. plumbeus*, Dussumier), about 8 ft. long, of a leaden-gray color, rather sluggish in its movements, with about 136 teeth, found on the coast of Malabar, near the shore, where it pursues the pilchards; the bridled (*D. frenatus*, Duss.), less than 6 ft.

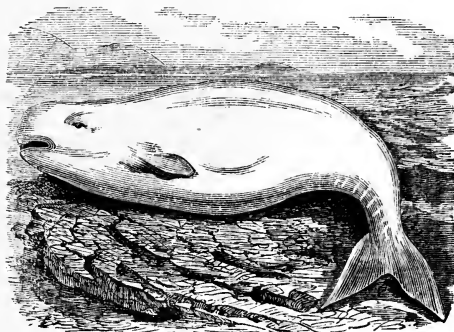

White Dolphin (*Beluga borealis*).

long, having on the ash color of the cheeks a black band extending from the angle of the mouth below the eye, found in the neighborhood of Cape Verd; the eye-browed (*D. superciliosus*, Lesson), about 4 ft. long, brilliant blackish blue above, silvery below, with a white streak over the eye, found in the neighborhood of Cape Horn; the *funenae* of the Chilians (*D. lunatus*, Less.), about 3 ft. long, with a slender beak, fawn-colored above, white below, with a dark brown cross on the back, in front of the dorsal fin, numerous in Conception bay.—Among the *delphinidae* which would not be better described elsewhere is the genus *delphinapterus* of Lacépède, having no dorsal fin, and a slender transversely flattened beak, separated from the cranium by a deep furrow. Péron's dolphin (*D. Peronii*, Cuv.) is about 6 ft. long, elegant in form and proportions, of a deep bluish black above, with the snout, sides, pectorals, abdomen, and part of the tail silvery white; the teeth are about 39 on each side of each jaw; like the rest of the genus, it is found in high southern latitudes. The allied genus *beluga*

(Bon.) has an obtuse, conical, and rounded head, without prominent beak, and without dorsal fin. The whitefish, or white whale (*B. borealis*, Less.), is a beautiful cream-white dolphin, symmetrical, and very swift; the length varies from 12 to 20 ft.; the teeth, according to Cuvier, are  $\frac{2}{3}$ - $\frac{3}{3}$ ; being well covered with fat, it is sometimes chased by coast whalers, especially about the mouths of rivers, where it feeds upon the cod, haddock, flounder, and other fish; it is essentially arctic, though it descends to the temperate regions of both hemispheres; it has been seen in the river St. Lawrence as high up as Quebec. The genus *globicephalus* (Less.) includes the *D. globiceps* (Cuv.), commonly called the deductor, social, bottle-head, blackfish, or howling whale; it resembles the *beluga* in the shape of the head, but differs from it in having a dorsal fin; the length is from 16 to 24 ft., and the general color a shining jet-black; the teeth are from 20 to 28 in each jaw; its favorite resort is the northern temperate ocean in both hemispheres; it is included by De Kay in the fauna of New York; it herds in great numbers, apparently following a leader, and is easily driven

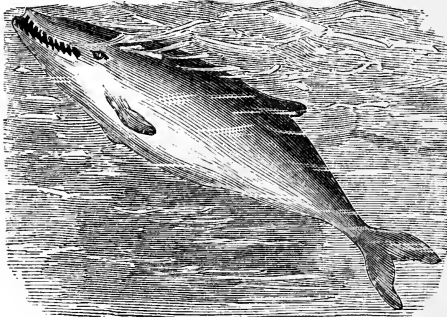

Deductor (*Globicephalus melas*).

upon beaches; the proper name is *globicephalus melas* (Less.). Some species of the genus have been found in the Mediterranean. The long-beaked dolphins (*delphinorhynchus*, Lacép.) have a prolonged snout, thin and narrow, not separated from the cranium by a furrow; the straight jaws are furnished with numerous sharp teeth, and the dorsal fin is single; some of the species attain the length of 36 ft. The best known, *D. micropterus*, Cuv., or *D. Sowerbyi*, Desm., is remarkable for the snout being four times the length of the cranium, and for the curvature upward and forward of the posterior part of the intermaxillaries, carrying with them the maxillaries, frontals, and occipital; it is a northern species, and has been found stranded on the French and English coasts. There are two remarkable genera of fresh-water dolphins, one of which, the dolphin of the Ganges (*platanista Gangetica*, Gray.), will be described under Soosoo, the Bengalee name. The other is the Bolivian dolphin (*inia Boliviensis*, D'Orb.), found in the tributaries of the Amazon and the neighboring

streams and lakes, even to the foot of the Andes; the beak is long, but cylindrical, bristled round with strong hairs, and obtuse at the end; the teeth are about 134, resembling incisors in

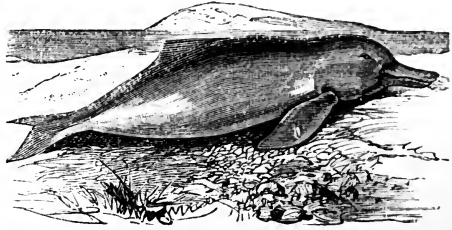

Bolivian Dolphin (*Inia Boliviensis*).

front and molars behind; the body is short and slender, the pectorals large, the dorsal small and behind the middle of the back; the skin is fine and smooth; the average length of the adult is about 7 ft.; the color varies from pale blue to blackish above, and is rosy beneath. It comes frequently to the surface, and is comparatively slow in its movements; its food consists almost entirely of fish, which are devoured with the snout above water; it is killed by the natives for its oil. This curious animal seems to form an intermediate type between the carnivorous and the herbivorous or sirenoïd cetaceans.—The *delphinidæ* are of little value to the whaler, as they are difficult to catch, and their covering of fat is much less than in the whales. Near the mouths of rivers and on the coasts herds of them are occasionally hunted with profit for their oil and their skins, and in high northern regions even for food. Many genera of *delphinidæ* inhabited the seas during the tertiary epoch, some very like the present dolphins, others very different from them. Their fossil remains are found abundantly in the miocene, pliocene, and diluvial strata of America and Europe.—The name of dolphin was long ago given by Dutch navigators to a scomberoid fish of the genus *coryphæa* (Linn.), inhabiting the Mediterranean and the seas of warm and temperate regions. The genus has no detached finlets, no isolated dorsal spines, and no armature on the tail; the body is moderately long, more or less compressed, and covered with small scales; there is a single dorsal fin, with flexible rays, extending from the head to near the caudal; the ventrals are thoracic. The generic name is derived from *κορυφή*, summit, in reference to the elevated shape given to the forehead by a bony crest of the interparietal and frontal which rises between the intermaxillaries and extends to the occiput; this gives a trenchant aspect to the head, with a very convex facial profile; the eyes consequently seem low. The mouth is large, having card-like teeth on the jaws and palatal bones. The dolphin of the Mediterranean, so famous for the beauty of its colors when dying, is the *C. hippurus* (Linn.). Many writers have followed the Dutch error as to the name of this

fish, and that of dolphin is taken away by sailors from the cetacean and given to the scomberoid. This species grows to the length of about 5 ft.; the colors are bluish green above, with azure and golden reflections, and citron yellow below, with pale blue tints; the pectorals are partly leaden and partly yellow, the ventrals yellow below and black above, the anal yellow, and the iris golden. In the Atlantic is the *C. equisetis* (Linn.), with a shorter body and more elevated head. On the coast of South America is the *C. dorade* (Val.), from the name given to the genus by the Portuguese. About a dozen other species are described in different parts of the globe. They are exceedingly active, strong, and voracious, pursuing the flying fish, forcing them to leave the water, and seizing them as they descend into it again. Nothing can be more beautiful in a calm sunny day, in the clear water of mid-ocean, than to see these brilliant creatures darting around the vessel, displaying their ever-varying tints of golden, blue, and green,

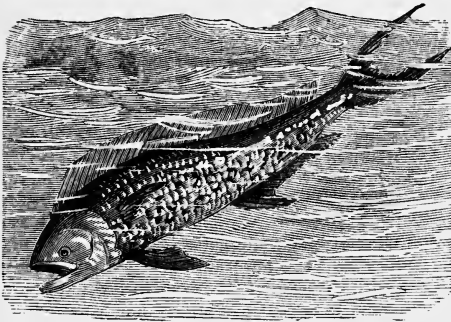

*Coryphæa dorade.*

with every movement. They gather around any floating object, and are readily caught by a hook or harpoon; when brought upon deck the beautiful play of rapidly changing colors commences, produced, as in the chameleon and the cuttle fish, by changes in the surface by muscular action, as may be seen by the constant undulation of the long dorsal fin. The flesh is considered good food; it is white, and rather dry. Sailors have an idea, which is probably true, that it is sometimes unwholesome and even poisonous, and they are in the habit of boiling a piece of silver money with the fish to detect the fact; if the piece be tarnished by the boiling, the fish is rejected; if it remain bright, it is fit for the table.

**DOMAIN**, or *Demesne* (mediæval Lat. *domanium*, the dominion of the lord), in England, lands retained by the great landed proprietors for their own use; the *terræ dominicales* or demesne lands being occupied by the lord or *dominus manoriæ*, while the other or tenemental lands are distributed among the tenants. The demesne lands of the king, *terræ dominicales regis*, which were at an early period very large, and to which additions were made by

forfeitures and otherwise, had been, at the time when Blackstone wrote, almost entirely alienated; but as a portion of them were not conveyed absolutely in fee, but upon long leases, they will revert to the crown upon the expiration of those leases. The principal importance of the royal demesne lands grows out of certain incidents that at an early period attached to the estate of the tenants of those lands. The tenure by which such estates were held is designated by old writers as ancient demesne; and to some extent it still continues to exist. Strictly, lands so held were copyhold, and as such were excepted by the statute 12 Charles II., c. 24, by which military tenures were abolished. One incident, showing that the tenure was originally a species of villenage, is that the lands do not pass by the common conveyances, but by surrender to the lord in the manner of copyhold estates, for certain uses mentioned in the surrender, and a new grant by the lord in pursuance thereof to the *cestuy que use*.—The public domain of the United States is almost beyond calculation. The original thirteen states embraced an area of 341,756 square miles. The whole territory conceded to the United States by the definitive treaty of peace of 1783 was 830,000 square miles. The concessions made by the states to the general government of lands claimed by them outside their respective limits constituted the nucleus of our public domain, which was afterward increased by the purchase of Louisiana from France and Florida from Spain, the annexation of Texas, the acquisitions from Mexico, and the purchase of Alaska from Russia, to a grand total of 2,912,784.74 square miles, or 1,864,382,223 acres, which has first or last belonged to and been subject to sale or other disposition by the government of the United States. For its sale the general system, which now for a long time has prevailed, is to cause it to be surveyed into townships six miles square, embracing 36 equal sections, and these subdivided into quarters, eighths, and sixteenths, and the lots sold at a uniform price of \$1 25 an acre. Full payment is in general required before giving title or possession; but preëmption privileges to the extent of 160 acres are allowed to settlers, who on complying with the formalities prescribed by law may enter and make improvements. A homestead not exceeding 160 acres is given to actual settlers who enter under proper claim and actually occupy for five years. In addition to these liberal provisions for settlers, large quantities of land have been given as bounties for military services, and munificent donations made for various public purposes. The lands designated in the public surveys as swamp or overflowed lands, but a considerable portion of which are only nominally such, have been generally given to the states within which they lie; every sixteenth section in a township has been set apart for the support of common schools; large endowments in lands have been made



for agricultural colleges and other institutions of learning, and still larger to the states or to private corporations for the construction of canals, railroads, and other public works. The general purpose of these grants is to facilitate settlement and advance the general prosperity, rather than to make the lands a source of revenue. Rapid as has been the disposal of public lands, 1,307,115,448 acres still remained unsurveyed and 1,387,732,209 84 unsold and unappropriated in 1870, according to the estimate of the United States land office; but this is subject to large deductions when the grants for railroad lines are earned and located.—The term domain is applied variously in other countries; but in general it embraces, 1, the high-ways, harbors, fortifications, &c. (as to which see EMINENT DOMAIN); 2, the government palaces and other public buildings, gardens, forests, parks, crown jewels, &c.; 3, forfeited estates and other property which the government may dispose of for revenue; 4, the private estate of the monarch, which he may dispose of by will or otherwise, but which if not so disposed of will pass to his successor.

**DOMAT**, or **DAMAT JEAN**, a French jurist, born in Clermont-Ferrand, Nov. 30, 1625, died in Paris in 1695 or 1696. For 30 years he was king's advocate at Clermont. His great work is *Les lois civiles dans leur ordre naturel* (5 vols., 1689-'97; English translation by W. Strahan, 2 vols. fol., London, 1737; edited by L. S. Cushing, 2 vols. 8vo, Boston, 1850). Domat is called by Victor Cousin "incomparably the greatest juriconsult of the 17th century," and by Boileau "the restorer of reason to jurisprudence." The intimate friend of Pascal, and his associate in many of his experiments in natural philosophy, he was distinguished for his taste for mathematics and philosophy as well as for legal attainments.

**DOMBROWSKI**, **Jan Henryk**, a Polish general, born at Pierszowice, Aug. 29, 1755, died at Winagora, June 16, 1818. He entered the army under Prince Albert of Saxony in 1770, where he rose to the superior grades and became aide-de-camp to Gen. Bellegarde. The diet of Warsaw having voted for the organization of an army of 100,000 men, and recalled all the Poles then in foreign service, Dombrowski joined the Polish forces commanded by Poniatowski in the campaign against the Russians in 1792, served with distinction in 1793, and took part in the insurrection of 1794 under Kosciuszko, but surrendered after the fall of Warsaw. Having rejected offers from both Russia and Prussia, he accepted a commission from the French directory in 1796 to enroll a Polish legion at Milan, and after serving in the Italian campaigns under Bonaparte, Gouvion Saint-Cyr, and Masséna, entered the service of the Cisalpine republic in 1802. In 1806 he joined Napoleon at Berlin, published a proclamation calling upon the Poles to rise, and soon entered Warsaw at the head of two national divisions. He was wounded in the

battle of Friedland, to the favorable issue of which he greatly contributed; in 1809 he fought with Poniatowski against the Austrians; in the Russian campaign of 1812 he commanded a division of the grand army; in 1813 his Poles fought bravely in Germany, particularly at Leipsic; and on the creation of the kingdom of Poland by the czar Alexander he was raised to the rank of general of cavalry and senator palatine. He soon after retired to his estates at Winagora, in the grand duchy of Posen, where he occupied himself with arranging his historical memoirs. He bequeathed his manuscripts, together with his library and collection of antiquities, to the society of the friends of science at Warsaw.

**DOME** (Gr. *δομος*, *δῶμα*, building; Lat. *domus*, a house; mediæval Lat. *doma*, a cupola), a concave covering to a building or part of a building. The Italians apply the term *il duomo* to the principal church of a city, and the Germans call every cathedral church *Dom*; and it is supposed that the word in its present English sense has crept into use from the circumstance of such buildings being frequently surmounted by a cupola. Some writers on architecture restrict the term dome to the convex surface of the roof, and cupola to its concave part. The dome may be a segment of a sphere, spheroid, ellipse, polygon, or any similar figure, but in all cases every horizontal section should have a common vertical axis; it is called surmounted when it rises higher than the radius of its base, surbased or diminished when its height is less than the radius of its base. The thickness should increase toward the base, where the structure is weakest, and where the spreading force of the superincumbent weight tends to burst the dome outwardly. To counteract this pressure, iron hoops or chains are often employed. When built of stone the dome is stronger than the arch, as the tendency of its parts to fall inward is resisted not only by the parts above and below it, but also by those on each side. The constituent pieces are formed somewhat like the frustum of a pyramid, so that when placed in their positions their four angles may point toward the axis of the dome. Each course is thus self-supporting, and not only may the whole be constructed without centering, but an aperture, called the eye, is frequently left in the top without damage to the security of the structure.—The dome seems to have been invented by the Romans or Etruscans, and in the time of Augustus was a common feature in Roman architecture. There is no proof that the Greeks or Egyptians had any knowledge of it, nor is it found in any of the early monuments of Hindostan, but after the Mohammedan invasion of India it was generally adopted in that country. The grandest dome that has remained to us from antiquity is that of the Pantheon at Rome, which, though 19 centuries have passed over it, still retains all its stability and magnificence. Its exterior presents the appear-

ance of a truncated segment of a sphere, considerably less than a hemisphere, and has a circular opening in the top 28 ft. 6 in. in diameter. The base consists of a large plinth, with six smaller ones above it. It appears that originally there were flights of steps at intervals all around the dome leading up to the eye, but only one such is now visible, the others having been covered with lead. The interior is a hemisphere of about  $71\frac{1}{2}$  ft. radius, and the distance from the floor to the top of the dome is equal to the diameter. The thickness is 17 ft. at the base, 5 ft.  $1\frac{1}{2}$  in. at the top of the highest plinth, and 4 ft. 7 in. at the eye. The ceiling is ornamented with five rows of quadrilateral compartments converging toward the top, each large compartment having four smaller ones sunk one within another, which were probably once ornamented with plates of silver or covered with bronze. The dome is built of brick and rubble, and rests on a circular wall 20 ft. thick. The baths of ancient Rome afford many examples of this kind of roof: those of Diocletian had three domes, two of which remain; and those of Titus are crowned by two, each 84 ft. in diameter. Near Pozzuoli is an ancient circular building with a dome of volcanic tufa and pumice stone, and the temple of Minerva Medica had a polygonal dome of ten sides, constructed of pumice stone and brick. That of the church of St. Sophia at Constantinople was built in the reign of Justinian, with the professed design of rivalling the glory of the Pantheon. The plan of the church was a cross, and at the angles of the square where the transepts cut the nave, the architect placed four columns at a distance of about 115 ft. apart, and over them threw arches. The triangular spaces at the corners were then filled up to a level with the extradoses of the arches, and on the ring thus formed the dome was built. In ignorance of the principle of hooping, the builder resorted to various expedients to resist the lateral pressure of the superstructure, and, after it had twice fallen in, was obliged to fill up the large arcades on the N. and S. sides with three tiers of small arches. This dome was destroyed by an earthquake a few years after its completion. The present one is of nearly the same diameter (107 ft.), 46 ft. high, supported by corbellings at the angles of the square, and encircled by a row of windows with exterior columns. It is surmounted by a lantern. The church of St. Mark at Venice, begun in 977, has five domes; the central one, which is much larger than the others, was hooped with iron in 1523. The dome of San Vitale at Ravenna consists of a hemisphere resting on an octagon with eight piers at its angles, and a window on each face. The great dome of the church of Santa Maria del Fiore, the cathedral of Florence, was begun by Arnolfo di Lapo or Arnolfo di Cambio da Calle about 1295, but after the death of the original architect (about 1300) no one could be found for upward of a century to finish it; it

was finally undertaken by Filippo Brunelleschi, who brought it nearly to completion. He improved upon the original design by carrying up perpendicular walls in the shape of an octagon to a height of 175 ft., and upon these placing two concentric domes, the internal one being 138 ft. 6 in. in diameter and 133 ft. 6 in. high from the top of the internal cornice of the supporting walls to the eye of the lantern. This is the first double dome with which we are acquainted. That of St. Peter's at Rome, the grandest in the world after that of the Pantheon, is also double. It stands upon four piers, each 61 ft. 11 in. high and 30 ft. 10 in. thick, from which spring arches supporting corbellings finished by an entablature. The entablature upholds a plinth, circular within and octagonal without, and on the latter rests a circular stylobate 28 ft.  $6\frac{1}{2}$  in. thick and 12 ft.  $4\frac{1}{2}$  in. high, divided into three parts by passages, forming flights of steps communicating with four spiral staircases in the thickness of the wall of the drum, which rises immediately from the stylobate. The drum is pierced with 16 windows, between which are a corresponding number of solid buttresses 51 ft. 6 in. high. Above it is placed a circular attic 19 ft.  $2\frac{1}{4}$  in. in height, and on this rests the great double dome, the internal diameter of which at the base is 138 ft. 5 in. and the external 148 ft. To the height of 27 ft. 8 in. the dome is solid. Its curve describes externally the arc of a circle whose radius is a little over 84 ft., and its height from the attic to the top of the internal dome is 83 ft. 10 in. It is pierced outwardly by three rows of small windows and strengthened by 16 projecting vertical bands. The whole is crowned by a lantern resting on a platform surrounded by an iron railing and having a cross on the top, the height from the external plinth of the dome to the cross being 263 ft. The top of the cross is 430 ft. above the ground line. This great work was planned by Michel Angelo, who died before its completion, and was finished under the pontificate of Sixtus V., who caused the exterior to be covered with lead, and the bands with bronze gilt. Owing to the haste with which the work was pushed forward the domes settled vertically in many places, and the band of iron around the inner dome was broken. Six iron circles were consequently placed around the outer dome, secured by iron wedges, and the fractured hoop was repaired. The dome of St. Paul's, London, built by Sir Christopher Wren, is double, and rests on an attic and a drum placed on four great arches over the intersection of the four naves. The external dome is of wood, covered with lead, and ornamented with panels formed by projecting ribs. It is surmounted by a lantern supported on a conical tower terminated by a spherical dome. The height of the tower is 86 ft. 9 in., and that of the whole structure from the ground line is 365 ft. The diameter of the dome is 145 ft., and its internal height from

the springing 51 ft. The dome of the Pantheon (or St. Geneviève's) at Paris is entirely of stone, and is supported by four triangular piers rising from the centre of a Greek cross. It is triple, having besides the inner and outer vaults an intermediate structure built to carry the lantern. The internal dome is 66 ft.  $8\frac{1}{2}$  in. in diameter at the springing; the external 77 ft.  $8\frac{3}{4}$  in. The height of the edifice above the ground line is 190 ft. The reading room of the British museum, opened in May, 1857, is covered by a magnificent dome 140 ft. in diameter and 106 ft. high from the ground. It is built principally of iron, with brick arches between the main ribs supported by 20 iron piers. Between the vaulting and the exterior covering of copper a space is left for the equalization of the temperature, and between the vaulting and the inner decorated ceiling is a similar air chamber for ventilation. There are 20 large windows around the base of the dome, and an eye in the top 40 ft. in diameter. The cast-iron dome of the capitol at Washington has a height of about 55 ft., and an internal diameter of 94 ft. 9 in. The height of its ceiling from the floor of the building is 220 ft. The exterior of the structure presents a peristyle 124 ft.  $9\frac{1}{2}$  in. in diameter, with columns 27 ft. high, from which springs an attic 44 ft. high, supporting the great dome of a semi-ellipsoidal form, the top of which is 230 ft. above the pavement. Above this rises a lantern, 52 ft. high and 17 ft. in diameter, crowned with a bronze statue of Liberty 18 ft. high. In the interior there is a vertical wall raised upon the cornice of the rotunda, with a panel 9 ft. high richly sculptured; above this is a series of attached columns and large windows, and above these springs a dome which, contracting to a diameter of 65 ft., permits a second dome, 73 ft. in diameter, resting also on a colonnade, to be seen through the opening.—Domes are sometimes made convex below and concave above, in which form they take the name of Moresque, Turkish, or Hindoo. In Russia they are very frequently built of a bulbous shape, and many of the churches are surmounted by five, representing Christ and the four evangelists. The Isaac's church at St. Petersburg, founded in 1819 and consecrated in 1858, has a central dome of iron covered with gilded copper, with a small rotunda rising from the centre; it is in the Byzantine form, having a diameter of 87 ft. 4 in. and a height of 275 ft. above the floor, or, including the lantern, of 327 ft. Four smaller domes rest on each corner of the edifice. The dome of the temple of the Saviour at Moscow, built to commemorate Russia's triumph over Napoleon, is 84 ft. in diameter; its interior height above the floor is 225 ft. 9 in., and its exterior height, including the cross on its summit, is 343 ft. This dome is supported by four pillars, each 21 ft. in diameter.

**DOMENECH, Emmanuel**, a French traveller and author, born about 1815. He early became a

priest, and went as missionary to Texas and Mexico, and on his return to France was appointed honorary canon of Montpellier. In 1862 he was chaplain of the French army in Mexico, and subsequently attached to Maximilian's cabinet. He has published *Journal d'un missionnaire au Texas et au Mexique* (1857); *Voyage dans les solitudes américaines* (1858); *Voyage pittoresque dans les grands déserts du nouveau monde* (1861); *Les Gorges du Diable* (1864); *Légendes irlandaises* (1865); *Le Mexique tel qu'il est* (1867); and *Histoire du Mexique, Juarez et Maximilien: correspondances inédites* (3 vols., 1868). Prim and others contested the historical veracity of the last named work. His *Manuscrit pictographique américain, précédé d'une notice sur l'idéographie des Peaux Rouges* (1860), was published at the expense of the government, with a facsimile of a manuscript in the library of the Paris arsenal, relating as he fancied to the American Indians, but which the German orientalist Julius Petzholdt declares to consist of scribbling and incoherent illustrations of a local German dialect. Domenech asserted the authenticity of the manuscript in a pamphlet entitled *La vérité sur le livre des sauvages* (1861), which drew forth a reply from Petzholdt, translated into French under the title of *Le livre des sauvages au point de vue de la civilisation française* (Brussels, 1861).

**DOMENICHINO**, or **Domenico Zampieri**, an Italian painter, born in Bologna in 1581, died in Naples, April 15, 1641. His first master was Dionysius Calvart, from whose tyranny he took refuge in the school of the Carracci, of which, in spite of a natural timidity and a slowness which his fellow pupils attributed to stupidity, he was eventually considered the most distinguished pupil. He lived apart from men, and rarely went abroad save to make studies for future use. After studying the works of Correggio at Parma, he joined Annibale Carracci at Rome, and assisted him in decorating the Farnese palace. He soon after received commissions from Cardinals Borghese, Farnese, Aldobrandini, and others, for whom he painted works which increased his reputation, but raised a host of enemies. His picture of the "Communion of St. Jerome," now in the Vatican, which has been called second only to Raphael's "Transfiguration," was discovered to bear a slight resemblance to a composition on the same subject by Agostino Carracci, and Lanfranco, a former fellow pupil, took advantage of the fact to decry the picture and the artist. Domenichino was finally compelled by the jealousy of his rivals to retire to Bologna, whence he was recalled by Gregory XV. in a few years to become principal painter and architect in the pontifical palace. Here he renewed his triumphs, and was invited to Naples to paint the chapel of St. Januarius, but died before the completion of his work, not without suspicion of poison. Among his chief works are the "Four Evangelists," in S. An-

drea della Valle at Rome, "Adam and Eve," the "Martyrdom of St. Agnes," and "Diana and her Nymphs." His fresco paintings, of which the scenes from the life of the Virgin in the Duomo at Fano are the best specimens, are admirable. His landscapes, although rather decorative, are uniformly good. He never wholly freed himself from the mannerism of his school, and was defective in invention; but in the free conception of nature, and in the expression of emotion, he approaches nearer Raphael and his contemporaries than any of the eclectics. Many of his works have been engraved by Raphael Morghen and others.

**DOMESDAY** (or **Doomsday**) **BOOK**, or **Book of Winchester**, a register of the lands of England, framed by order of William the Conqueror. According to some historians it was begun in 1080 or 1083, according to others at the close of 1085; the book itself records its completion in 1086. Persons called the king's justiciaries

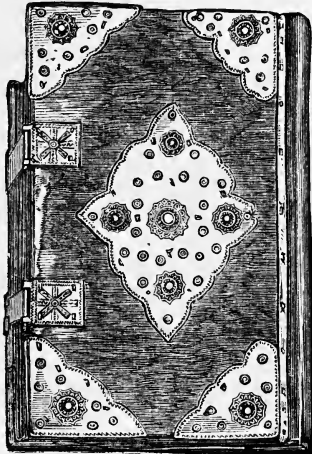

Domesday Book.

visited in person or by deputy the greater part of the kingdom, and obtained the required particulars on oath from the sheriffs, lords of manors, parish priests, reeves of hundreds, bailiffs, and villeins of each vill. The record contained a list of the bishops, churches, religious houses, great men, king's manors, king's tenants *in capite*, and under tenants; the particulars of the name of each place, its holder, its extent, the extent of wood, meadow, and pasture, the ponds and mills, the quantity of live stock, the value of the whole, the homages of each manor, the number of villeins, *cotarii*, *servi*, and freemen, and how much each freeman or socman had. Three estimates of the estates were made, viz.: as they were in the time of Edward the Confessor; as they were bestowed by William; and as they were at the time of the survey. The jurors were, moreover, required to state whether any advance could be made in the value. The returns of the justiciaries were sent to Winchester, and being there digested

were entered in two volumes, which were carried about with the king and great seal, or deposited in a chapel or vault of the cathedral called *Domus Dei*. From the last circumstance the name Domesday is thought by some to be derived. Others ascribe it to a parallel drawn between the decisions of the book and those of the day of doom. The first volume, called the "Great Domesday," consists of 382 folio pages closely written on vellum, and contains the survey of 31 counties; the second, or "Little Domesday," is in quarto, of 450 pages, and comprises the returns from Essex, Norfolk, and Suffolk. It has also a list of "invasions," or lands possessed without royal authority. Northumberland, Cumberland, Westmoreland, and Durham do not appear in the record, for which various reasons are assigned. Other counties are described, either wholly or in part, under adjacent divisions. No account is given of Winchester or of London. As a census of the population the Domesday book is of no value, but with regard to the ancient tenure of lands its authority is supreme. It names only 1,400 tenants *in capite* and 8,000 under tenants, and enumerates only 282,242 inhabitants. The book is now preserved in the chapter house at Westminster. A facsimile of it was published by order of government in 1783, having been ten years in passing through the press; and in 1816 the commissioners of public records published two supplementary volumes, one containing a general introduction to the survey with indexes, and the other the four similar records called the "Exon Domesday," the *Inquisitio Eliensis*, the *Liber Winton*, and the "Boldon Book," or survey of Durham. The last of these was made by Bishop Hugh Pudsey in 1183; the *Inquisitio Eliensis* is of the 13th century; the others are contemporary with the Domesday book. In the exchequer office are two other large volumes under the latter title, which are merely abridgments of the original register. Many interesting particulars relating to the survey are found in Kelham's "Domesday Book illustrated" (8vo, London, 1788), and in Morgan's "England under the Norman Occupation" (1858). A facsimile of the portion of Domesday book relating to Cornwall, produced by photozincography, was published in 1861.

**DOMICILE**, the place where by law a man is deemed to reside. There has been much confusion and conflict of opinion as to what shall constitute a person's domicile, which, as will be seen, is not necessarily the same as his residence. The general conclusions may be stated as follows: 1. The domicile of the parents at the time of a child's birth is the child's domicile, though if the child be illegitimate it takes the domicile of the mother. 2. The domicile of origin continues until a new one is acquired, and the domicile of the husband and father is presumptively that of the wife and children, though if they reside apart from him, not temporarily merely, but by permanent voluntary

or judicial separation, they are capable of acquiring a distinct domicile of their own. 3. The domicile of origin is lost immediately when a person of full age, or legally competent to act for himself, takes up his abode elsewhere with the intention of abandoning the former and of remaining permanently in such new place of abode. To these rules it may be added that presumptively the place where a man lives is his domicile, where nothing to the contrary appears. The law of domicile is specially important as regards the transmission and disposition of property. While the conveyance and descent of real property are governed by the law of the place (*lex rei sitæ*), personal property, on the other hand, for the purposes of distribution in cases of insolvency and intestacy, and also of disposition by testament, is to be governed by the law of the owner's last domicile. This is a principle universally recognized, without regard to the location of the property, except that a state may doubtless exercise the right to appropriate property actually within its limits to the satisfaction of claims due to its own citizens, to the exclusion of claimants abroad. As regards belligerent rights and liabilities, if a person reside in a country which is at war with another, his property will be lawful prize as belonging to a belligerent; or if the country be neutral, he is entitled to the privileges of a neutral in respect to *bona fide* trade. The residence which gives this neutral right is sometimes spoken of as a domicile, but it is obvious that the term as thus used has no other meaning than actual residence and engagement in business, which it will be seen does not *per se* constitute a domicile in respect to other legal incidents. A single exception is made in the case of a person who leaves his own country *flagrante bello*, it being thought inconsistent with his natural allegiance that he should be permitted to enter into neutral relations with the enemy after war had actually commenced. On the same principle greater strictness would probably be insisted upon in regard to the nature of the residence when the question was between the emigrant and his native country, even if he went abroad before the breaking out of hostilities; yet it is difficult to see how even in that case it could be required that a domicile should have been acquired other than results from actual residence abroad for *bona fide* business purposes.—The rule of the civil law that a man may have two domiciles, as where he resides a part of the year in one place and a part in another, or where he is carrying on business in two places, is repudiated in England and in the United States.

**DOMINIC, or Domingo** (called DE GUZMAN since 1555), a saint of the Roman Catholic church, and founder of the order of preachers, or friars preachers, born in Calahorra, Old Castile, in 1170, died in Bologna, Aug. 4, 1221. His father's name was Felix. His mother, Juana de Aza, revered as a saint in Spain, placed him

in his seventh year with his uncle the arch-priest of Gumiel de Izan, and at the end of his 14th sent him to the university of Palencia. At the age of 20 he lost his mother, commenced the study of theology and canon law, and in his 25th year was in priest's orders, teaching dogmatic theology and Scripture in the university, and creating a wonderful impression by his sermons. About this period he sold his furniture and books to relieve the poor during a famine, and offered himself in bondage to the Moors to redeem a Christian prisoner. In 1198 the bishop of Osma, Martin de Bazan, appointed him a canon of his cathedral, and promoted him to the dignity of sub-prior and arch-deacon when he soon after reformed his chapter. Diego de Azeves (or Azevedo), De Bazan's successor, chose Dominic as his associate, when charged in 1203 with negotiating the marriage of the heir of Castile with a princess of Lusignan. In passing through southern France the ambassadors were grieved at the disorders prevalent among nobles and churchmen, and the dangers to the Catholic church from the spread of the Albigensian doctrines. Dominic was entertained in Toulouse by a leading Catharist, who questioned him on their doctrinal differences, and acknowledged on the spot his own error. This, historians say, gave Dominic the first idea of founding a society of learned priests devoted exclusively to the work of preaching. The matrimonial negotiation having been happily concluded, the ambassadors were again despatched to escort the bride to Castile, but they only arrived in time to see her carried to her grave. This event, and what they had witnessed in their second journey through Languedoc, inspired the ambassadors with the resolution of trying in their own persons what preaching supported by a life of self-denial could effect to win back the Catharists, and rouse Christians of all classes to a sense of duty. They proceeded to Rome, obtained the approval of Innocent III. with a two years' leave of absence for the bishop, and were soon back in Montpellier, where they met the legates commissioned to suppress heresy in the ecclesiastical province of Narbonne. These were Cistercian monks, living in great state, while the Catharists avoided all reprehensible display. The bishop forthwith dismissed his retinue, induced the legates to do likewise, placed himself at their head, and they all set out on foot for Narbonne and Toulouse. They preached to the Catholics in the churches, and held conferences with the Albigenses in their houses. At Caraman, near Toulouse, they made a number of conversions; in Béziers, where the Catharists were in a majority, Dominic's eloquence attracted large multitudes, but produced no effect otherwise; in Carcassonne, where the bishop of the city had been exiled, they met with insult; and, turning once more toward Toulouse, they stopped at Fanjaux for eight days. There occurred an event much dwelt upon by Dominic's early

biographers. In a public conference a doctrinal exposition was drawn up on both sides, and presented to the Catharists chosen to preside. Unable to agree, both manuscripts were submitted to the test of fire, Dominic's remaining, as it is said, untouched by the flames. It was at Fanjaux that he conceived the project of erecting a monastery for the education of daughters of poor but noble parents, who were the object of Catharist proselytism. Foulques, just appointed bishop of Toulouse, gave him for that purpose the church of Notre Dame de Prouille, near which a monastery was begun at once, and soon became one of the educational centres of France. In the spring of 1207 this first series of missions was concluded by a two weeks' conference at Montréal, near Prouille, when the test of fire was again resorted to, and 150 persons abjured the Catharist doctrines. The bishop of Osma had now to return to his diocese, leaving Dominic at the head of the missionaries. His death and the murder of Peter de Castelnaud occurring almost simultaneously, Dominic saw himself forsaken by all but a few secular priests just as the crusade against the Albigenses commenced. He remained with his little band in the neighborhood, watching, says the early biographer, over his rising establishment of Prouille, and increasing his efforts to gain or to retain the good opinion of the Albigenses. For seven years was the land wasted by religious and civil war. Dominic has often been represented as one of the instigators of this bloody strife, but, as appears, unjustly. He and his companions ceased not to preach to the afflicted populations, and to terrify into humanity the swarms of freebooters (*routiers*) who infested the country. He is only mentioned once in the authentic acts of this war, as having been seen praying in the church of Muret on Sept. 13, 1213, while the battle was going on outside between the forces of De Montfort and the king of Aragon. Dietrich of Apolda, his earliest historian and almost his contemporary, says of him during these years, "He continued to combat heresy by his discourses, his examples, his miracles." Another writer of the epoch mentions his name once in connection with the punishment of heretics, and it is to tell how Dominic saved one poor wretch from the stake. From the records of that period we gather that during this whole war Dominic never ceased to labor in Languedoc; that he was respected by the leaders on both sides; that (save in the single instance mentioned above) the authentic acts do not speak of him; he is named in no letter sent to Rome, in no letter coming from it, and in no official document published there concerning the war, the inquisition, or the punishment of Albigenses. The devotion of the rosary, established by him in those days, indicates an influence far from sanguinary. (See ROSARY.) In 1215, at the fall of Toulouse, Dominic with his companions repaired thither. He had seen how little of religious pacification

the crusade had achieved, and what seeds of hatred it left behind. His old idea of trying what an army of true priests could effect now returned. Foulques, the bishop of Toulouse, applauded it. Six of his fellow missionaries had resolved to follow him in realizing it. One of them, Pierre Cellani, a native of the city, appropriated his own house for their residence; and the bishop assigned them the church of St. Romain, with the sixth part of all the diocesan tithes for their support, appointing them at the same time "preachers in the diocese of Toulouse." Innocent III., solicited by the bishop and Dominic, encouraged the project, which was in accordance with the recommendations of the 18th Lateran council, but bade Dominic choose for his society one of the existing rules of monastic orders. Hastening back to Toulouse, Dominic found 16 companions where he had left six, and took them with him to Prouille, where after much deliberation they adopted the rule of St. Augustine, modified in accordance with their proposed mode of life. On Dec. 22, 1216, two separate bulls of Honorius III. approved and confirmed the new society; and a third, issued in the following January, is addressed to them as "preachers in the country of Toulouse," and "preachers" has been their official title ever since. Dominic was at the same time appointed *magister sacri palatii* (master of the sacred palace), that is, theologian and spiritual director of the pontifical household. On Aug. 15, 1217, Dominic and his brethren recited their solemn religious vows in the church of Prouille before a vast concourse of persons of every rank. After the ceremony he proceeded to carry out his design of taking possession of the three great centres of learning, Paris, Bologna, and Rome. After making his brethren elect a superior general to serve in his absence, he set out for Rome on foot and with a single companion, seven of the remaining religious being despatched the same day to Paris. On Dominic's arrival in Rome, the pope assigned to him the vacant church and ruinous cloister of San Sisto on the Cælian hill. Dominic, besides preaching frequently to the papal household, preached also in every church in Rome, sometimes delivering several discourses daily. By order of the pope he reformed at this time the female monasteries of Rome, making the cloistered nuns observe a strict reclusion, and giving them the rule and habit of St. Augustine. This was the origin of the Dominican nuns. At this time also he founded a "tertiary order" or "third order of penitence," composed of persons of both sexes and all ranks of life, bound by no vows, nor required to quit their secular occupations and domestic duties, but taking on themselves the obligation of avoiding worldly pleasures and vanities, of repairing the wrongs they had committed, of being true and just in all their dealings, and of practising charity according to their means. The establishment of San Sisto was soon given up to the Dominican

nuns, and the rapidly increasing community of friars was transferred by the pope to Santa Sabina on the Aventine, where his own palace was. The flower of the nobility and priesthood now demanded admission to the new order; and among the postulants were Hyacinth and Ceslas Odrowaz, since canonized, nephews to the high chancellor of Poland, and Reginald, dean of the chapter of Orleans and doctor of canon law in the university of Paris, whose eloquence and learning were chiefly instrumental in establishing the friars preachers in Bologna. In the autumn of 1218 Dominic, after visiting Languedoc, where the existence of his establishments was threatened, founded a convent in Madrid, and another in Segovia, which became the Dominican centre in Spain. Thence, at the invitation of Blanche of Castile, he went to Paris, where he found the seven sent from Prouille increased to 30, and occupying at the Narbonne gate the church and hospital of St. Jacques, from which the Dominicans in France derived their denomination of Jacobins. After establishing houses in Limoges, Rheims, Poitiers, Metz, and Orleans, he set out for Bologna. On arriving there in the summer of 1219 he found that the church and convent of Mascarella, first given to his brethren, had been exchanged for the church and convent of St. Nicholas, which has been considered as the cradle of the Dominican order in Italy. Reginald's eloquence had taken the city and university by storm; the *élite* of the professors and students had entered the novitiate, and Dominic found a sufficient number to send to the chief cities of northern and central Italy to found houses there. It was at his first arrival in Bologna that he tore in pieces a deed presented to him by a wealthy citizen of all his personal estates. He declared he wished to see his followers beg their bread rather than clog their usefulness by the possession of property. This love of poverty he extended to everything connected with his order, dwelling, furniture, and fare; he even banished from the churches all splendid vestments, and confined the use of silver and gold to the service of the altar. Dominic and Francis of Assisi met this year in Perugia, and the former proposed to unite into one body the two societies which they had founded, a proposal to which Francis would not listen. But both, when asked by Cardinal Ugolino, in whose house they met, if they would allow their sons to accept ecclesiastical preferments, replied that it would be the ruin of religious humility. Dominic was present in 1219 at the first general chapter of the Franciscans, and in 1220, at the first general chapter of the friars preachers, made the Franciscan legislation concerning religious poverty binding on all his followers. The second general chapter was held in Bologna May 30, 1221. It was attested by numerous witnesses at his canonization, that in bidding farewell to the professors and students of Bologna, he predicted he should cease

to be among the living before the 15th of August following. Acting on this presentiment, he went to Venice to recommend his order to Cardinal Ugolino, afterward Pope Gregory IX.; and after visiting some of his followers elsewhere he arrived in Bologna July 31, 1221, wayworn and faint. He persisted in attending the midnight service with the community, and on retiring to his cell was seized with a violent fever accompanied with dysentery. He refused to accept a bed offered to him, but lay on a sack filled with wool. On the morning of Aug. 4 he warned those around him that the end was at hand. They laid him, at his request, on sackcloth and ashes, where he received the sacraments of the dying, pronounced a fervent blessing on his children far and near, and breathed his last as noon was about to strike.—The life of Dominic has been written, among many others, by Dietrich of Apolda and several other ecclesiastical writers of the 13th century; by Castillo (Madrid, 1584), Nicholas Janssen (Antwerp, 1622), Tournon (Paris, 1739), and Lacordaire (1840, 1844, and 1858). See also *Saint Dominique et les Dominicains*, by Elme Marie Caro (Paris, 1853); the Bollandists, under date of Aug. 6; and the first volume of Mamachi's *Annales Ordinis Prædicatorum* (Rome, 1756).

**DOMINICA**, a British West India island, one of the Lesser Antilles, Leeward group, 29 m. S. of Guadeloupe, in lat. 15° 18' N. and lon. 61° 32' W.; length from N. to S. 29 m., breadth 16 m.; area, 291 sq. m.; pop. in 1870, 28,517, of whom only a small number are whites, the majority being emancipated slaves. It is of volcanic origin, and when viewed from the sea presents the appearance of a confused mass of mountains; the highest summit has an elevation of 5,300 ft. Dominica has upward of 30 rivers and numerous rivulets, sulphurous and thermal springs, and a deep lake on a high mountain 6 m. from Roseau. Among its mountains are many fertile valleys, with a black and rich soil well adapted for raising every tropical production. The temperature ranges from 69° to 88°. The wet season continues from September to January, though rains frequently fall during the other months. The chief exports are sugar, molasses, rum, coffee, and cocoa; the chief imports are wheat, flour, dried fish, linen, and cottons. In 1870 the imports were valued at £60,277, the exports at £62,246; the revenue was £15,721, the expenditures £15,248, the public debt £7,230. There are 16 free schools; but the majority of the population being Roman Catholics, education is mainly in the hands of the clergy. The woods swarm with bees, which produce great quantities of wax and honey. This is the European bee, much larger than the native bee of the West Indies.—Dominica was discovered by Columbus in 1493; and being equally claimed by England, France, and Spain, it was considered a neutral island by those three powers till 1759, when it was captured

by the English; and it was ceded to England by France in 1763. It was recaptured by the French in 1778, and restored to England in 1783. Its government is administered by a lieutenant governor, aided by an executive council of 7 members, and a legislative assembly of 14 members, of whom 7 are nominated by the crown and 7 elected by the people. Capital, Roseau, on the S. W. side of the island; pop. about 5,000.

**DOMINICAL LETTER** (Lat. *dominica*, the Lord's), the letter used in the calendar to denote Sunday for a given year. The council of Nice (325) established the rule that Easter Sunday should be the first Sunday after the full moon which happens upon or next after March 21. For the purpose of determining when Easter falls, and for other similar problems concerning the day of the week and the day of the year, it was early found convenient to place the first seven letters of the alphabet in succession against the days of the months, putting A to Jan. 1, and repeating the seven letters as often as necessary until Dec. 31. The letter which falls against the first Sunday in January will fall against every Sunday in the year, and this is the dominical letter for that year, unless it be leap year; and then, as Feb. 29 as well as March 1 is marked D, the dominical letter for the last ten months of the year will be the preceding letter of the alphabet. Finding the dominical letter will enable one to find what day of the week a given date in the year is. But the dominical letter, being known for any one year, can be found for any other, by simply remembering that an ordinary year is 52 weeks and 1 day, a leap year 52 weeks and 2 days, so that the dominical letter will go backward from G toward A, one letter for a common year and two for a leap year. This gives rise to an arithmetical rule which may be thus expressed: To the number of the year add one quarter of itself, neglecting fractions, and divide the sum by 7; then for the 19th century subtract the remainder from 8, or, if it is 0, from 1, and the new remainder will indicate the place of the dominical letter in the alphabet; for the 18th century subtract from 7; for the 17th century, and back to 1582, the year in which the Gregorian calendar went into operation, subtract from 6, or if the remainder is 6, from 13; for dates previous to 1582 subtract from 3, or if the remainder is 3 or more, from 10. But the dominical letter thus obtained for a leap year belongs to the time after Feb. 29, and for the preceding two months the dominical letter was the succeeding letter in the alphabet. This new remainder is also the date of the first Sunday in January for that year. The same date in February will fall on Wednesday; in March, on Wednesday; in April, on Saturday, &c.; as may be seen from the fact that the first days of the 12 months have annexed to them in the calendar the initials of the words: At Dover Dwell George Brown, Esquire, Good Christo-

pher Finch, And David Friar. For example, the day of the week on which New York was incorporated, June 12, 1665, is thus found:  $(1665 + 416) \div 7 = 297$ , with a remainder of 2; and, it being the 17th century,  $6 - 2 = 4$ , which shows the dominical letter for that year to have been D. Then, as June begins with E, June 1, 1665, was Monday, and the 12th was Friday. President Barnard of Columbia college gives the following rule for finding the dominical letter: Give to the letters A, C, E, G, in which order the dominical letters return with the leap year centennial in every succession of four centennial years, the numerical values which correspond to their places in the alphabet, 1, 3, 5, 7; find in this series the number corresponding to the given century, and call this the centennial; multiply the twenties of the incomplete century by 3, and call the product the vigesimal; multiply the fours in the excess of twenties by 2, and call the product the quaternial; multiply the final remainder by 6, and call the product the residual. If the sum of the numbers thus obtained is 7 or less, it is the numerical value of the dominical letter; if it is greater than 7, subtract 7 as often as may be necessary to reduce it to 7 or below, and the final result is the dominical letter.

**DOMINICAN REPUBLIC.** See SANTO DOMINGO.

**DOMINICANS, Order of Preachers, or Friars Preachers** (Lat. *Fratres Prædicatores*; Fr. *Frères-Prêcheurs*), a Roman Catholic monastic order, founded by St. Dominic. (See DOMINIC.) When in 1215 Dominic and his six companions took up their abode in Toulouse, in the house of Pierre Cellani, they had agreed to wear the habit and follow temporarily the rule of the canons regular of St. Augustine. This rule and habit had been given by St. Norbert, in 1121, to the community founded by him at Prémontré, which spread so rapidly throughout Europe. St. Norbert aimed at uniting the observances of monastic life with the office of preaching and the cure of souls. To the Augustinian rule, as it existed before him, he added several regulations tending to stricter poverty and greater severity of life. The rule of St. Norbert, so modified as to make it still more austere, was that which Dominic and his companions deliberately chose in Prouille in 1216, and which was approved by Honorius III. in his two bulls of Dec. 22 of the same year. The new features given by St. Dominic to the rule of Prémontré may be thus described: 1. As the order of preachers has for its object the salvation of souls by preaching and other priestly ministrations, as well as by the example of a holy life in the preacher, the superior of every convent has discretionary power to dispense from the common rules and observances, which may occasionally prove obstacles to the end in view. Thus, where fasting or abstinence is incompatible with preaching, teaching in public, necessary study, or the fatigues of a missionary life, the superior is empowered to grant a relaxation; the rule of



silence in the interior of the monastery is dispensed with when strangers apply for spiritual instruction or comfort; and no unnecessary time must be given to the recitation of the divine office in the church, or the performance of church ceremonies, when the duty of preaching and careful preparation for it are more urgent. 2. Each convent is governed by a "conventual prior;" each province, composed of a certain number of convents within a definite territory, by a "provincial prior;" and the whole order by a "master general" (*magister generalis*), called simply "general." Every charge, from the highest to the lowest, is elective. The conventual prior is chosen for three years by the priests in each convent who are six years professed; the provincial prior is chosen for four years by the conventual priors, former provincial priors residing in the province, functionaries called fellows (*socii*) of the provincial, chosen one by the members of each convent, and the priests appointed to the office of "preachers general;" the master general is elected every six years by the provincial priors, *diffinitores* chosen one by each province, who accompany the provincial to the general chapter, fathers enjoying the dignity of masters in theology, and former masters general. On the other hand, the general confirms the election of the provincials, and the provincials that of the conventual priors. General chapters, held at short intervals, control the administration of the general; provincial chapters serve as a check upon the provincial prior; while in each convent a council assists the prior in his government of the house. This economy, equally removed from oppression and from license, is favorable to manly independence and natural freedom of action, and has preserved the order of preachers from the divisions which have rent asunder the Franciscans. It was the aim of their founder that strict poverty should be the corner stone of the edifice he was rearing; hence the order was to accept no property that needed to be managed, but only the income derived from it. To this rule the Dominicans remained faithful until the multiplication of their houses, the apparent necessities of the times, the solicitations of princes and bishops, the authority and even the command of popes, gradually led them to modify and relax the stringency of the original legislation on the holding of property. In the first years of their existence their extreme poverty contributed not a little to their wonderful growth in numbers, efficiency, and influence. They had early taken possession of Rome and Bologna, where their masters in theology, philosophy, and canon law became the controlling intellectual power; and from these great centres they spread through all the chief towns of Italy. In Paris they, as well as the Franciscans, met from the very commencement with nothing but disfavor and opposition on the part of the university. In 1228 they obtained one professorship, and in 1230 a second. The popularity

which their lectures enjoyed, and the superiority attributed to them by the public, excited even at that early period fierce denunciations against the "begging preachers and friars." But, besides the two public chairs in the university thus filled by the Dominicans, there were a considerable number of others teaching in the schools of Paris; for it was the rule that no one should receive a degree of "master of arts" who had not taught for three years under the direction of the Parisian faculties. The Franciscans, too, were at that time neither less ambitious of intellectual preëminence, nor less successful, nor less numerous in the schools of Paris. So, besides the vehement emulation which existed between the two new mendicant orders, there arose a bitter hatred against both among the secular professors of the university. After many bickerings, this feeling broke out into a scandalous quarrel in 1252, on the occasion of a refusal by the friars to suspend their courses in conformity with the university rules. The friars and their disciples by public decree were for ever excluded from all university honors, and the faculty went so far as to bind both professors and students by oath to maintain this exclusion. King and pope had to interfere; and it was only in 1260 that a compromise was effected which was most oppressive to the Dominicans. Still the two great orders persisted in sending to Paris their most renowned doctors and most promising scholars; and then began the intellectual contest between the two rival schools of philosophy and theology, represented by Dominicans and Franciscans, which is the history of the European mind during the middle ages. Just as the quarrel with the university broke out Albertus Magnus had come to teach in Paris, bringing with him his disciple Thomas Aquinas, and to these two greatest names among the Dominicans was soon added Vincent of Beauvais. On the side of the Franciscans were found Roger Bacon, Alexander of Hales, John Duns Scotus, and St. Bonaventura. The theological supremacy which the teaching of Thomas Aquinas soon gave to the friars preachers, together with the undisputed control exercised by them in the schools of Bologna, and the official position as supreme theological and literary censors held in Rome by the "masters of the sacred palace," continued down to the time of the Jesuits to exercise decided influence over the intellectual life of Europe.—Their missionary activity meanwhile kept pace with their mental culture. When the second general chapter of the order was held in Bologna in 1221, under St. Dominic himself, 60 conventual establishments were already in existence. The field over which their labors actually or prospectively extended was mapped out into eight provinces, among which were England and Hungary; and before the assembly dispersed, Dominic despatched missionaries to take possession of these two kingdoms. Gilbert de Frassiniet with 12 companions soon pre-

sented himself to the archbishop of Canterbury, who sent them to labor in Oxford, where they built a chapel in honor of Our Lady, and founded schools called "St. Edward's schools," from the parish in which they were situated. Robert Grosseteste, bishop of Lincoln, was so pleased with the new comers that he asked the general of the order to send him a Dominican as a coadjutor. Not only bishops, jealous for the salvation of their flock, but princes such as Louis IX. of France, careful of the welfare of their subjects, eagerly sought to have near them men who could enlighten the multitude by their doctrinal expositions and edify them by a blameless life. This was the need of the age, pressed on the attention of bishops by the last council of the Lateran. They therefore spread rapidly, and, as Neander remarks, their advent was hailed everywhere as a benefit, among the poorer classes especially, to whose wants they ministered, and whose poverty and privations they willingly shared. Carrying out the oft expressed wish of their founder, they also crossed over into Asia, where they did much both among the Mohammedans and eastern schismatics. In 1233 they were appointed conjointly with the Franciscans to carry out the new rules of the inquisition in France. Though this tribunal never exercised permanent authority outside of Languedoc, the connection of the mendicant orders with it became a principal cause of unpopularity in the rest of France. The use which the court of Rome made of the friars in collecting moneys added much to these commencements of disfavor; while the ministrations for which they were called into the houses of the great made their enemies say they were afraid to reprove princes and prelates for their misdeeds. In 1245 occurred their first official departure from the rigorous poverty which had hitherto attracted many to the order of Dominic; they were authorized by the holy see to accept donations and legacies. In 1277 the order had 35 convents for men in Spain, 52 in France, 32 in Tuscany, 46 in Lombardy, 53 in Germany, 36 in Poland, 28 in Denmark, and 40 in England, besides some in other countries, and a large number of nunneries. In 1278 the convents amounted to 417; and the number went on increasing until the reformation, when they lost upward of 400 establishments in the Protestant countries. In the 15th century the Dominicans were chosen to preside over the Spanish inquisition, when that tribunal became a state establishment. Under Philip II. and his successors, although ecclesiastics had but little to do with the working of that institution, the odium created by such men as Torquemada attached to the Dominicans in public estimation. With the rise of Jesuits about 1543 came a new era of rivalry and intellectual activity for the old monastic orders. In every centre of civilization in the old world, and on every field of missionary duty in the East and West, Jesuits and Dominicans vied with each other

in learning and zeal. The latter had followed Albuquerque and his Portuguese to the East Indies, where they had founded everywhere flourishing missions; and there Francis Xavier found them at work when he began his career some 40 years later. The Dominicans followed in like manner the Spaniards and Portuguese to America. From 1503 to 1616 no fewer than 16 "expeditions" were sent by the Dominicans to the Antilles and all parts of North and South America, each expedition made up of a large number of religious; besides which small bands of missionaries were continually crossing the ocean to fill up the voids caused by death, &c. After the example of Las Casas, the friars preachers were everywhere the benefactors of the native races, and their protectors against European brutality.—In the middle of the last century the order possessed upward of 1,000 convents, distributed into 45 provinces, 11 of the latter being out of Europe. By the French revolution they lost all their establishments in France and Belgium, and during the reign of Napoleon I. nearly all their convents in Germany, and very many in Italy. Three convents are allowed at this time (August, 1873) to remain open in Rome. Elsewhere throughout the Italian peninsula they are suppressed by law. In Bologna, the cradle of the order, three priests and two lay brothers are permitted to live in a private house; the grand old convent of St. Nicholas is shut up, the splendid church with all its treasures of art is ignored as a place of worship, and a few religious who still cling to the memories of the place are allowed to visit it daily, and see that no harm befall its monuments. In the German empire the recent law suppressing the Jesuits makes no mention of the friars preachers. In France the order was restored by Lacordaire under Louis Philippe. Several houses were established by him, among them a flourishing college at Sorèze, and another at Arcueil, near Paris, some of whose professors and pupils were massacred by the communists, May 19, 1870. There are at present two provinces of the order in France and one in Belgium. In England there are five Dominican convents, and in Ireland 12 with about 50 priests. In Spain, Portugal, and Russian Poland they have ceased to exist. In the Austrian empire they are still tolerated. In the United States there are eight houses of the order, six east of the Rocky mountains and two in the Pacific states, numbering in all 70 priests. In Spanish and Portuguese America the Dominicans lead a precarious existence, constantly exposed to the political caprices of the parties in power. In 1872 they were expelled from Guatemala. In spite of these adverse circumstances, the Dominicans still maintain their missionary establishments in European Turkey, Asia Minor, Armenia, India, China, and Anam. Eastern Anam had at the beginning of this century 25 convents of native nuns, numbering some 600 inmates. In spite of the

persecutions which have repeatedly dispersed and sometimes decimated them, these establishments, protected by France, are beginning to flourish anew. Various attempts have been made to restore the order to the rigor of its pristine observance; among them one in the beginning of the 17th century, by Père Michaélis, provincial of Toulouse, which so far succeeded that in 1608 Pope Paul V. erected the reformed convents into an independent congregation, governed by a vicar general. In 1650 Père Le Quien endeavored to push this reformatory movement still further; he established six convents in Provence and the comtat Venaissin, which embraced the primitive rule in all its rigor. When Pius IX. announced (June 19, 1847) his intention of reforming the monastic orders, Lacordaire and his French Dominicans were among the first to encourage him and to accept the proposed change; it was a Frenchman, Père Jeandel, who was appointed vicar general by the pope when he suspended for a time the authority of the general chapter. Since then the work of reform has been carried on incessantly, the calamities which have befallen the order making it easier for the true-hearted among its members to embrace, as their assured pledge of future usefulness, the high abnegation of their founder.—The influence exercised by the order of preachers on the schools of the middle ages and on the whole of European society for several centuries cannot be exaggerated. It has given to the whole world such men as Albertus Magnus, Thomas Aquinas, Vincent of Beauvais, Master Eckard, John Tauler, Henry Suso, Savonarola, Las Casas, Vincent Ferrer, and a host of other distinguished names; and in our own day the friars preachers have seen their ancient glory revive in Lacordaire, and in Monsabré, who now fills his place in Notre Dame de Paris; as well as in Father Thomas Burke, who in 1872-'3 traversed the United States, thrilling everywhere by his eloquence vast assemblages of his countrymen. It has given to the church a host of bishops and archbishops, 66 cardinals, and four popes, Innocent V., Benedict XI., Pius V., and Benedict XIII. The influence of the order on the fine arts has exceeded that of all others. "The Dominicans," says Mrs. Jameson, "have produced two of the most excellent painters who have drawn their inspirations from religious influences, Angelico da Fiesole and Bartolomeo della Porta," called Il Frate in the schools. Among countless monuments of painting and sculpture executed for their former monasteries and churches, is the famous "Last Supper" by Da Vinci, in Sta. Maria delle Grazie in Milan. As to the Dominican nuns, the house founded in Prouille by St. Dominic, and which afterward adopted his rule and habit, became the parent of many similar institutions throughout France. In Rome the Dominican nuns, and the "third order" established by Dominic, spread through Italy. The nuns however did not long maintain the original severity of their

rule. They shared also, in France, in the various attempts at reform made by the monks. At present they have convents in France, Belgium, Austria, Bavaria, Switzerland, in the British empire and some of its colonies, as well as in North and South America.—See Altamura's *Bibliotheca Dominicana* (fol., Rome, 1677); Castillo's *Historia general de Santo Domingo y de su orden de predicadores* (2 vols. fol., Madrid, 1584-'94; 2d ed., 5 vols. fol., Valladolid, 1612-'21); Touron, *Histoire des hommes illustres de l'ordre de Saint Dominique* (6 vols. fol., Paris, 1743); and Riboll, *Bullarium Ordinis FF. Predicatorum* (8 vols. fol., Rome, 1729-'40).

**DOMINIS, Marc' Antonio de**, a theologian and natural philosopher, born in Arbe, an island of Dalmatia, in 1566, died in Rome in September, 1624. He was a relative of Pope Gregory X., studied at Loretto under the direction of the Jesuits, and became a member of their order. He taught mathematics and philosophy with great success in several cities of Italy. In 1602 he left the Jesuits, and was appointed archbishop of Spalato and primate of Dalmatia and Croatia. He now began to oppose some of the measures of the court of Rome, and his writings were condemned by the inquisition. This gained him the sympathies of Protestants, by whom he was induced in 1616 to pass into England, where he embraced Protestantism, and was made dean of Windsor. Though his avowed aim was to effect a reunion of the two great divisions of Christendom, he wrote and preached against the papacy. In his work *De Republica Ecclesiastica*, he maintained that the pope is only *primus inter pares*; it was censured by the theological faculty of Paris, and burned by order of the inquisition. Not long after its publication he reverted to his former theological views, publicly retracted all that he had ever written against the Roman Catholic church, and repairing to Rome abjured his apostasy. His inconstant humor did not long leave him in repose, and it was suspected that he had repented his last conversion, and was meditating a return to Protestantism. He was imprisoned by Pope Urban VIII., and his sudden death soon after caused the report that he was poisoned. His trial for heresy was continued after his death; he was convicted, and his body was disinterred and burned along with his writings. His chief philosophical work is entitled *De Radiis Visus et Lucis* (Venice, 1611), to which Newton ascribes the first true explanation of the rainbow.

**DOMINOS**, a game which has been traced by some authors to the Greeks, Hebrews, and Chinese. Its first appearance in western Europe is not ancient, it having been introduced into France from Italy about the middle of the last century. The domino is a small flat oblong of wood, ivory, or bone, divided on one side by a line into two compartments. Each of these is marked with a certain number of dots, from 1 to 6, or is left a blank, so that upon

each domino there is a different combination of numbers. The game is played with 28 dominos, the reverse sides of which are unmarked and all alike. This side being up, each player takes an equal number of the dominos. The person who has drawn the one which has the highest number of points puts it down; the next domino played has to be one with a number the same as one of the two numbers presented by the first, and the two similar ends are joined. The next may match the remaining number of either the first or the second domino, and thus the game continues till one player has put down all his pieces. There are a number of variations in the mode of playing this game. The combinations are neither very varied nor intricate, and yet it requires memory and calculation.

**DOMITIAN (Titus Flavius Domitianus Augustus)**, a Roman emperor, born Oct. 24, A. D. 51, killed Sept. 18, 96. He was the younger son of Vespasian, and narrowly escaped death at Rome by concealing himself when his father was proclaimed emperor by the legions of the East. On the fall of Vitellius he ruled the capital as Cæsar till the return of his father. Having then exhibited a sanguinary and licentious temper, he was excluded both by Vespasian (69-79) and Titus (79-81) from all share in public affairs, and spent his time on an estate near Rome, in effeminate pleasures, as well as in writing and reciting poetical compositions. On the death of Titus, which was ascribed to him by the people, he was hailed emperor by the soldiers. At the beginning of his reign he concealed his vices, and even manifested some firmness in the regular management of affairs; but he soon began to display his vanity and jealousies. Almost every citizen of Rome who was noted for wealth or learning was either murdered or banished. In his wars he was personally unsuccessful against the Catti and other German tribes, as well as against the Dacians, whose king Decebalus compelled him to purchase peace on humiliating terms. These reverses, however, did not prevent him from triumphing and decorating himself with the names of Germanicus and Dacicus. Government officials, says a historian, were busy in keeping the people of Rome from laughing on such occasions. Games were employed to amuse them. Agricola, the heroic commander in Britain, was recalled because of his victories, and the jealousy of his fame probably caused his subsequent death. War having been terminated by an ignominious peace with Decebalus in 89, Domitian satiated his thirst for blood at home, until, as Tacitus says, silent fear reigned at Rome. After many fruitless conspiracies, he was finally killed by three officers of his court who had been warned of their intended death by the emperor's wife Domitia, whom he had also doomed.

**DOMRÉMY**, or *Domrémy la Pucelle*, a village of Lorraine, France, on the Meuse, in the department of Vosges, 7 m. N. of Neufchâteau, the

birthplace of Joan of Arc. The cottage in which she was born had become a stable, but was repaired in 1820 at the expense of the government, and a free school for girls connected with it. A chapel has also been dedicated to her, and a monument raised in her honor, to which Louis Philippe contributed in 1843 a cast of the statue of the maid of Orleans executed by his daughter Princess Marie.

**DON** (Lat. *dominus*, lord or master), a title of honor among the Spaniards, the feminine form being *doña*, and the corresponding title among the Portuguese being *dom*. It is used even by the king and the royal princes, and was formerly assumed by the nobility only with the consent of the sovereign, but is now merely a title of respect used by all classes. *Dom* is also sometimes employed in France as a clerical title. The old English form of the word is *dan*, frequently used by Chaucer.

**DON. I.** A river of Russia, the Tanais of the ancients, and the Tuna, Duna, or Dana of the Tartars. It is one of the largest rivers of Europe. It rises in a small lake in the government of Tula, flows S. E. and S. W., passes Voronezh, Pavlovsk, Novo-Teberkask, Teberkask, Nakhitchevan, Rostov, and Azov, and enters the sea of Azov by three mouths, only one of which is navigable. Its length, including windings, is nearly 1,000 m., though from its mouth to its source in direct line is but 468 m. In summer navigation is difficult, but in winter the water is high enough, and the stream becomes navigable to Zadonsk, about 800 m. from its mouth. The course of the river lies through a low country, covered with vast forests of oak and pine. The current is sluggish, and sand banks, over which there are often only two feet of water, are of frequent occurrence. Opposite Dubovka the Don approaches the Volga to within 40 m., and a railroad connects the two rivers between Kalatch and Tzaritzin. The principal tributaries are the Sosna and the Donetz on the right, and the Voronezh (or Voronetz), the Khoper, the Medveditza, the Sal, and the Manitch on the left. **II.** A river of Aberdeenshire, Scotland, next to the Dee in size, but of little commercial importance. It rises on the declivity of Ben Aven, flows a tortuous easterly course of about 70 m., and enters the North sea near Aberdeen. It is navigable for a very short distance from the sea. Near its mouth stands the celebrated one-arched Gothic bridge of Balgowrie. A handsome new bridge of five arches has been built a little below the old structure. The salmon fisheries of the Don are of considerable value. **III.** A river of Yorkshire, England, 55 m. long, rising near the borders of Cheshire, and flowing into the Ouse. It is navigable from Sheffield, a distance of 40 m., and communicates by canal with the Trent and the Calder.

**DOÑA AÑA**, the S. E. county of New Mexico, bounded E. by Texas, and S. by Texas and Mexico; area, about 20,000 sq. m.; pop. in

1870, 5,864. The Rio Pecos intersects the E. part, and the Rio Grande flows through the W. portion. Several mountain ridges cross the country. The chief productions in 1870 were 23,324 bushels of wheat, 98,590 of Indian corn, and 14,000 lbs. of wool. The value of live stock was \$71,740. Capital, Doña Aña.

**DONALDSON, John William**, an English scholar, born in London, June 10, 1811, died there, Feb. 10, 1861. He was educated at the university of London and at Trinity college, Cambridge, where he graduated in 1834, and was made a fellow in 1835. After being some time assistant tutor there, he took orders and became head master of the grammar school of Bury St. Edmund's. In 1835 he resigned, and removed to Cambridge, where he gave a course of lectures on Latin synonyms, and occupied himself with private teaching and writing. In 1856 he was appointed one of the classical examiners of the university of London. In 1860 he travelled for his health in Germany, but returned without improvement, and removed to London, where he resided until his death. His most celebrated work is "The New Cratylus" (1839; 3d and enlarged ed., 1859), which was the first attempt on a large scale in England to bring out the principles of comparative philology established by German scholars. His *Varronianus* (1844) undertook to accomplish for Latin philology what "The New Cratylus" had done for Greek. "The Theatre of the Greeks," his earliest work, is still used as a college text book. He also published grammars of the Greek, Latin, and Hebrew languages, editions of Pindar, and the "Antigone" of Sophocles, and was engaged on a new Greek lexicon when his health failed. He also wrote *Jasher*, *Fragmenta Archetypa Carminum Hebraicorum* (Berlin, 1854; London, 1860), an attempt to restore the "Book of Jasher," alluded to in the Scriptures, and "Christian Orthodoxy" (London, 1857).

**DONATELLO**, or properly **Donato di Belto di Bardi**, one of the revivers of sculpture in Italy, born in Florence in 1283, died in 1466. His parents were poor, and he was brought up by a rich relative. He at first applied himself to painting, but subsequently to sculpture, and found in Cosmo de' Medici, the chief of the Florentine republic, a patron able to perceive and to reward his merits. The "St. Peter" and "St. Mark" which adorn the church of St. Michael in his native city were his first great works. He afterward studied in Rome, and occupied himself with repairing the injuries to the ancient sculptures. He particularly excelled in works in *rilievo*, among which were the "Nativity and Burial of Christ" and the "Assumption of the Virgin." His group of "Judith and Holofernes," executed in bronze for the community of Florence, that of "St. George," the finest ornament of the church of St. Michael, and his "Zuccone," representing an old man in the costume of a senator, have met with the approbation of succeeding times.

He was buried in the church of San Lorenzo, by the side of Cosmo de' Medici. Nothing irritated him more than to see his works sold to persons unable to appreciate them, and he sometimes broke a finished piece to save it from such a destiny.

**DONATI, Giovanni Battista**, an Italian astronomer, born in Pisa in 1826, died in Florence, Sept. 20, 1873. In 1852 he became an assistant in the observatory of Florence, where he soon gained distinction, especially by his discovery, on June 2, 1858, of the comet which bears his name. He had been anticipated in a similar discovery made in 1854; but he established his claims of priority in those seen by him on June 3, 1855, Nov. 10, 1857, and July 23 and Sept. 9, 1864. He also made important investigations on the spectra of comets, the solar disk, and the stars, and in 1862 published *Spectra di quindici stelle*. In 1864 he visited England, and in the same year succeeded Prof. Armi as director of the observatory of Florence. Through his exertions was inaugurated in 1872 the royal observatory on the hill of Arcetri, near Florence, memorable as the site of Galileo's tower. He was director of this and professor of astronomy in the royal institution of Florence at the time of his death, just previous to which he had represented Italy in the international meteorological congress at Vienna.

**DONATISTS**, a party in the ancient north African church, so called from two of their leaders named Donatus. In 311 Mensurius, bishop of Carthage, died, and the majority of the clergy and people hastened to choose in his stead his archdeacon, Cæcilian. This election was ratified by the bishops of the province of Carthage, one of whom, Felix of Aptungis, acted as consecrator. All this haste loth in the election and consecration was to avoid the interference of the bishops of the neighboring province of Numidia, between whom and Mensurius a bitter strife had existed on the treatment of the lapsed and the validity of all priestly acts performed by an unworthy minister. As Cæcilian had been a strong supporter of Mensurius throughout his administration, Secundus, the primate of Numidia, and Donatus, bishop of Casæ Nigræ, his counsellor, were particularly anxious to exclude him from the succession. No sooner had Cæcilian been consecrated than Secundus and Donatus arrived at the head of 70 Numidian prelates. Two deacons, competitors of Cæcilian, now became his accusers before this assemblage of bishops, to which none of the suffragans of Carthage were admitted. The validity of Cæcilian's ordination was impugned, because Felix of Aptungis, they said, was a *traditor*, that is, one who had given up the Scriptures and sacred vessels to the pagans during the late persecution of Diocletian. As Cæcilian, though willing to submit to a new election, refused to acknowledge the Numidian bishops as his lawful judges, he was deposed and the lector Major-

rinus was consecrated bishop of Carthage. Thus there were two bishops at the same time in the one see, each with a powerful party of bishops and laymen. The disorders which ensued were so great that in 312 Constantine expressly excepted "the party of Majorinus" from the privileges which his first edicts conferred on the churches of Africa. The aggrieved party thereupon appealed to him, and requested to be judged by a court of Gallic bishops. The emperor referred the matter to Melchιάdes, bishop of Rome, who pronounced the charges against Cæcilian groundless, and declared the leading accuser, Donatus of Casæ Nigræ, guilty of several transgressions of ecclesiastical law. Donatus and Majorinus appealed a second time to Constantine, begging to have the whole matter judged in Gaul, where the late persecution had not raged and no traitors existed. The emperor acquiesced, appointing a council to meet in Arles, and commanding the proconsul of Carthage, Ælian, to investigate judicially the accusation against Felix of Aptungis. Ælian pronounced Felix innocent, and convicted his accuser of having falsified the record in order to sustain his charge. The council of Arles met Aug. 1, 314; bishops from Italy, Spain, Gaul, Africa, and Great Britain heard both parties, and reaffirmed the sentence of the court of Rome. The emperor was once more appealed to, and summoned both parties before himself at Milan in 316. His decision was in conformity with that of the ecclesiastical courts. But Donatus and Majorinus and their followers raised the cry that Constantine had been biased in his decision by Hosius of Corduba. The emperor now had recourse to legal repression, and severe edicts were issued against "the party of Majorinus." In the same year, 316, Majorinus died, and was succeeded by a second Donatus, a man of great learning, austerity of life, and enthusiastic and headlong disposition. His followers gave him the appellation of Great, and from him called themselves "the party of Donatus," while their opponents styled them Donatists. He excited his followers to resist the imperial edict. Fearful retaliations followed everywhere the attempts to coerce the Donatists, and at length in 321 Constantine suspended the execution of his edicts, but the conflict between the parties still continued. In 330 upward of 200 Donatist bishops met in council, enacted decrees favorable to the reconciliation of traitors, and proclaimed themselves the only true church of Christ. Unfortunately for their cause, it had been espoused from the beginning by a large class of fanatics known as *circumcelliones*, "hut-rovers," in the rural and mountainous districts of northern Africa. They had contributed not a little to provoke the barbarities of the pagans during the late persecution, by committing deeds of violence and folly while the persecution lasted, in order to secure martyrdom for the faith. From the beginning of the schism they had

been the soldiers of the Donatists. Constans on his accession determined to employ both bribery and coercion against the Donatists. His commissaries Macarius and Leontius distributed everywhere large sums of money and rich presents in the emperor's name, accompanying them with exhortations to Christian unity, and threats of serious repression against recalcitrants. Donatus of Carthage repelled the imperial officer and his presents. "What has the emperor to do with the church?" exclaimed he, although he and his party had been the first to invoke the imperial intervention. Donatus sent his warning voice through all northern Africa, and the whole country rose in arms. In 349 Macarius defeated the united forces of the *Circumcelliones* in a pitched battle near Bagaja or Bagais, and then no alternative was left the vanquished but extermination or submission to the emperor's edicts. Their churches were taken from them, and their religious meetings were dispersed by force of arms. The accession of Julian in 361 brought them peace; their churches were restored, and their confiscated property was given back to them. The wild excesses into which they were hurried by this short-lived triumph only made their condition more intolerable under Gratian and his successors. Internal divisions added to their sufferings. In 393, 100 Donatist bishops assembled at Cabarsussi in the Byzacena, deposed Primiānus of Carthage, and ordained in his stead Maximian, his accuser. In 394 a council of 310 bishops reversed this sentence; but still the Donatists continued split into two factions, the "Primiānists" and "Maximianists." During the latter half of the century the voice of theological controversy had been heard above the unceasing clash of arms. Parmenian, successor of Donatus of Carthage, had vindicated his followers in works which were refuted by such men as Optatus of Mileve and Augustine of Hippo. But reasoning and argument could not be listened to amid this civil and religious warfare. In 398 Augustine, after trying in vain to bring about a peaceful discussion of their mutual grievances, obtained an order that the bishops of the province of Carthage should meet yearly to devise means of healing the schism. In 411 at length a fortunate concurrence of circumstances led to what is known as the great conference of Carthage, in which, under the presidency of the imperial commissary, Marcellinus, 286 Catholic bishops and 279 Donatists discussed during three days the points which divided them. Once more the two oft disputed questions were argued on both sides, whether Felix of Aptungis and Cæcilian were traitors, and whether the church, by communicating with unworthy members, lost the character of the true church of Christ. What then shook the allegiance of many Donatist bishops to their party was the offer made in the conference by the Catholics to receive the Donatist bishops

on a perfect footing of equality with themselves in every episcopal city. This gave a blow to the schism from which it never recovered. The most stringent measures of repression were immediately put in force against the obstinate, with the unavoidable results of agrarian violence and retaliation. In 429 Genseric and his Vandals swept over all northern Africa, an invasion which proved equally destructive to Catholics and Donatists. The latter still maintained a foothold along the Mediterranean coast and in the mountains for the remainder of the century, and then disappeared altogether.—The Donatists held that the sacraments from the hand of one not properly ordained for the work were of no value, rebaptized those who came from the Catholic churches into their communion, and consecrated anew the sacred edifices which they took from their rivals. Donatus and others of his party were accused of denying the Trinity; but from this charge they are absolved by Augustine, who shows that they differed from the Arians in recognizing but one divine substance.—Accounts of the Donatists may be found in the works of St. Optatus; in the writings of Augustine, in the 9th part of the Benedictine edition, the appendix of which also contains monographs relating to them; in Tillemont, vol. vi.; in the "Dissertation" of Collina (Bologna, 1758); in Ballerini's history; in De Potter's *Histoire du Christianisme*, vol. ii. (Paris, 1836); in Villemain's *Tableau de l'éloquence chrétienne au V<sup>e</sup> siècle* (new ed., 1854); and in Ribbeck's *Donatus und Augustinus* (Elberfeld, 1857).

**DONAUWÖRTH**, a town of Bavaria, in the district of Swabia and Neuburg, situated at the confluence of the Wörnitz with the Danube, 25 m. N. N. W. of Augsburg; pop. about 3,500. It has manufactures of linen and leather, and some trade in corn, flax, wool, and cattle. It sprang up around the castle of Wörth, and became an imperial city. The inhabitants early embraced the reformation, and in 1606 so misused the Catholics that the city was in the following year placed under the ban of the empire. This punishment was one of the causes of the thirty years' war. In the war of the Spanish succession Marlborough and Louis of Baden achieved here a victory over the French and Bavarians (July 2, 1704).

**DON BENITO**, a town of Estremadura, Spain, near the left bank of the Guadiana, in the province and 57 m. E. of the city of Badajoz; pop. about 15,000. The town is well built, with wide and clean streets, and several public squares. It contains a prison and a convent. Woollens, wine, and oil are manufactured here, and considerable trade is carried on, both by the river and by rail.

**DONCASTER**, a town of England, in the West Riding of Yorkshire, 32 m. S. of York; pop. in 1871, 18,758. It is on the river Don, which is here navigable, and in a cultivated district. Its grain market is the largest in the kingdom,

and it has manufactures of agricultural machines, iron, brass, and linen. But it is chiefly noted for its horse races, established in 1703. The famous St. Leger stakes were founded in 1776. The race course is nearly two miles in length, and one of the finest in the kingdom. The races are held annually in the third week of September, and continue for five days. Doncaster is the *Danum* mentioned in the itinerary of Antoninus; hence its Saxon name *Dona Castre*, and its present name. The town was frequently sacked by the Danes. Prior to the reformation, it was the seat of several convents of Carmelites, and white, black, and gray friars. A new parish church, to replace the old one destroyed by fire in 1853, was finished in 1858, at a cost of £52,000. Roman antiquities are frequently found in the city and vicinity.

**DON COSSACKS, Land of the, or Province of the Army of the Don**, a government of South Russia, lying between lat. 46° 10' and 51° 10' N., and lon. 37° 10' and 44° 15' E., and bordering on the governments of Saratov, Astrakhan, Voronezh, Kharkov, and Yekaterinoslav, the sea of Azov, and Caucasia; area, 61,934 sq. m.; pop. in 1867, 1,010,135. It is generally flat and sandy, the greater part of it being a steppe, but in the south there are low hills, the last of the ramifications of the Caucasus. It belongs to the basin of the Don, which receives several important tributaries within its limits, the principal of which are the Donetz on the right bank, and the Manitch and the Khoper on the left. The climate is generally mild and agreeable, but intense cold and violent storms sometimes prevail in winter. Cattle raising is the chief employment of the inhabitants; but along the rivers, where the soil is good, agriculture is followed with fair results. The cereals are raised to some extent, as well as hemp and flax, and light wines, scarcely inferior to those of France, are made. Fish constitutes a large part of the food of the people, sturgeon, salmon, and carp abounding in the rivers. Caviare made from the roe of the sturgeon is highly esteemed, and is exported in large quantities. Another chief article of export is salt, which is made from saline lakes in the south of the province. The seat of government is at Novo-Teberkask, at the confluence of the Aksai with an arm of the Don. (See COSSACKS.)

**DONDERS, Frans Cornelis**, a Dutch physician, born at Tilburg, May 27, 1818. He studied at the university of Utrecht, practised at the Hague, and for many years has resided at Utrecht, where he has established an institution for treating diseases of the eye, with a physiological laboratory, completed in 1867. His system of treating ophthalmic diseases is set forth in his elaborate work, *Die Lehre von den Augenbewegungen* (Utrecht, 1847). Among his other works are *De leer der stofwisseling als bron der eigenwarmte* (1845), *Natuurkunde van den Mensch* (Ger. translation, 2d ed., Leipzig, 1859); *Ueber die Natur der Vocale* (1858);

and "Anomalies of Accommodation and Refraction" (published in English by the Sydenham society; Ger. translation, Vienna, 1866).

**DONEGAL**, a maritime county of Ireland, bounded N. and W. by the Atlantic, E. by the counties of Londonderry, Tyrone, and Fermanagh, and S. by the counties of Fermanagh and Leitrim, and by Donegal bay; area, 1,865 sq. m.; pop. in 1871, 217,992. The shores are deeply indented by bays, the most important of which, Lough Swilly, penetrates 25 m. into the land. There are numerous islands off the coast, and several lakes within the county. The general aspect of the surface is mountainous. Nearly two thirds of the land consist of bogs or sterile hills, incapable of cultivation. The chief rivers are the Swilly and the Finn, and the principal towns Ballyshannon, Letterkenny, Ramelton, Donegal, and Killybegs. Oats, barley, flax, and potatoes are the staple agricultural productions. In 1868 there were 231,245 acres under cultivation. The fishery districts in 1867 employed 1,074 boats, with 3,766 men and 778 boys. Linen manufacture is carried on, and there are also many flour mills; the export trade is chiefly through the port of Londonderry. Capital, Lifford.—The town of **DONEGAL** (pop. about 1,600), at the head of a bay of the same name, 29 m. N. E. of Sligo, gives the titles of marquis and earl to the Chichester family.

**DONETZ**, a river of southern Russia, the principal affluent of the Don. It rises in the government of Kursk, pursues a S. E. course through the government of Kharkov and the country of the Don Cossacks, and joins the Don on the right. Its entire length is about 500 m. Its banks are generally fertile, and its channel is wide and deep. The Oskol, the Aidar, the Kalitva, and some smaller branches join it on the north; and it is navigable up to Zmiev.

**DONGOLA**, a province of Upper Nubia, in the valley of the Nile, between lat. 18° and 19° 30' N., including the narrow strip on both banks, between the river and the desert; pop. about 60,000. Nearly all the fertile land is on the left bank, the right being mostly barren and covered with drifting sands. The climate is agreeable and generally healthy, although fevers are prevalent in the rainy season, and the heat is great from March to July. On the annual rise of the Nile the low lands along the banks are submerged to the breadth of 12 or 15 m. Thus irrigated and enriched, the country is remarkably productive, yielding two crops annually. Corn and dates are the chief products, but cotton, tobacco, coffee, opium, indigo, sugar cane, beans, and saffron are also raised. The horses of Dongola are of a superior breed, larger than the Arabian. The inhabitants are chiefly of the Ethiopic race, and are of lighter color than other Nubian tribes. Many are descendants of the Mamelukes, who established themselves there in the beginning of this century. They are represented to be indolent, immoral, and selfish, and, notwith-

standing the fertility of the soil, live in abject poverty. Their principal occupations are cattle raising and trading in slaves.—The chief town is New Dongola or Marakah, the capital, on the left bank of the Nile, lat. 19° 10'; pop. about 6,000. It is the seat of a pasha, and has government offices, a bazaar, an indigo factory, and baths. It owes its origin to the barracks built there about 1820, after plans of the naturalist Ehrenberg, to take the place of those destroyed by the Mamelukes at Old Dongola. Not far from the town is the island of Argo, in the river, on which are numerous colossal Egyptian monuments and other remains. Old Dongola, the former capital, on the right bank of the river, 75 m. above New Dongola, is situated on a rock about 500 ft. high, and is surrounded by fortifications which show its ancient importance. It is now a miserable village of a few hundred inhabitants.—Dongola was a Christian country in early times, and was the seat of civilization and power in Nubia. In the 18th century it was overrun by the Sheikia Arabs. About 1812 the Mamelukes, expelled from Egypt, fled thither and attempted to found a government, but they were driven out in 1820 by Ibrahim Pasha, and since that period the country has been a dependency of Egypt.

**DONIPHAN**, a N. E. county of Kansas, bounded N. by Nebraska, and separated from Missouri on the east by the Missouri river; area, 391 sq. m.; pop. in 1870, 13,969. It is watered by the Missouri and several small streams, is well timbered, and abounds in building stone. The surface consists in part of rolling prairies, somewhat broken near the streams, but gently undulating in the interior. The river bottoms have a rich soil, generally timbered. The old overland route to California crosses the county, and the St. Joseph and Denver City and the Atchison and Nebraska railroads traverse it. The chief productions in 1870 were 158,117 bushels of wheat, 1,326,968 of Indian corn, 148,676 of oats, 28,822 of barley, 206,705 of potatoes, 6,640 tons of hay, and 194,396 lbs. of butter. There were 4,124 horses, 3,868 milch cows, 6,759 other cattle, 4,588 sheep, and 23,272 swine; 8 flour mills, 10 saw mills, 2 manufactories of saddlery and harness, and 1 of woollen goods. Capital, Troy.

**DONIZETTI**, *Gaetano*, an Italian composer, born in Bergamo, Sept. 25, 1798, died there, April 8, 1848. He was originally destined for the law, but showing an unusual taste for art, he was placed at the musical institute of Bergamo, then under the direction of Simon Mayer, and subsequently studied at Bologna, under Pilotti and Mattei. At the age of 20 he had composed some short pieces of religious and instrumental music, when the brilliant career of Rossini captivated him, and he determined to write for the stage. His father opposed his plans, and in a pique Donizetti entered the Austrian military service, and while in garrison with his regiment in Venice pro-



duced in 1818 his first opera, *Enrico di Borgogna*. Several other works followed, and in 1822 his *Zoraide di Granata*, produced in Rome, procured him his discharge from the army. His works now succeeded each other with great rapidity, and in 1827 he accepted an engagement with the director of the theatres at Naples, to write four operas a year, two serious and two buffo, for four years. In 1830, when his *Anna Bolena* was produced at Milan, he had written 31 operas, nearly all of which were moderately successful. At this time Bellini appeared, and Donizetti, who had hitherto been a professed imitator of Rossini, modified his style by borrowing somewhat of the pathos of his young contemporary. He went to Paris in 1835 to compete with him, but without success, his *Marino Faliero* being eclipsed by Bellini's *Puritani*. He returned to Naples, and in six weeks composed his *Lucia di Lammermoor*, the success of which consoled him for his disappointment. In 1840 he returned to Paris, and brought out *Les martyrs*, *La favorite*, and *La fille du régiment*. The reputation acquired by these and other works procured him the appointment of professor of counterpoint at the royal college of music in Naples, and of chapelmaster and composer to the court of Vienna. His last operas were *Don Sébastien* (produced at Paris in 1843, which he wrote out in two months, remarking at the close of his labors, "*Don Sébastien* will be the death of me") and *Catarina Cornaro*, produced at Naples in 1844. Soon afterward a mental affection, the result of early habits of dissipation and of excessive application, compelled him to abstain from work, and for the last few years of his life he was the inmate of a lunatic asylum. In addition to the works specified, he composed *Luzerezia Borgia* (Milan, 1833), *Linda di Chamounix* (Vienna, 1842), *Don Pasquale* (Paris, 1843), and *Maria di Rohan* (Vienna, 1843). He produced more than 60 operas, most of which, in consequence of the haste and carelessness with which he wrote, have sunk into obscurity. In the fulness and variety of his melodies, and in his appreciation of dramatic fitness in single or concerted scenes, he stands almost unrivalled, and some of his works will probably long retain their hold upon popular favor. His facility was such that he was known to write out the score of an opera in two days.

**DON JUAN**, a mythical personage, a type of licentiousness and dissipation, accomplished and wicked, represented with all the graces which win woman's heart, and all the snares which beguile woman's virtue. According to tradition, the patrician family Tenorio of Seville was the first to produce a Don Juan sufficiently remarkable to become the representative man of the order. His life is placed by some legends in the 14th century under the reign of Pedro the Cruel, and by others in the 16th century in the era of Charles V. He is represented to have been in the act of abduct-

ing a daughter of the governor of Seville when caught by her father; a duel ensued, in which the governor was slain. A statue having been erected to the deceased in the family vault in the convent of San Francisco, Don Juan enters the vault and invites the statue to join him in his revels. The stony guest appears at the banquet to the great amazement of Don Juan, and terminates the festivity by consigning his entertainer to the infernal regions. The story was first dramatized at the beginning of the 17th century by the Spanish poet Gabriel Tellez, commonly called Tirso de Molina, under the title of *El burlador de Sevilla, ó el convidado de piedra*. This drama, soon after its publication, was adapted for the Italian stage, and thence found its way to Paris, where it became the basis of several French adaptations, of which Molière's *Don Juan, ou le festin de pierre*, and Thomas Corneille's production, modelled after Molière's play, are the most celebrated. In England a play written by Shadwell, called "The Libertine," and treating the same subject, was performed in 1676. The subject was not produced on the Spanish stage in its present form till the early part of the 18th century, when it was rewritten by Antonio de Zamora. This version of Zamora furnished the groundwork of the modern treatment of the theme. Goldoni published his *Giovanni Tenorio* about the middle of the 18th century. Gluck followed with a ballet in 1761, Vincenzo Righini with an opera, and Lorenzo da Ponte with the text to Mozart's opera in 1787, which appeared in the same year. This is the masterpiece of this great composer, and at the same time the most remarkable production to which the legend of Don Juan has given rise. Apart from the opera and the drama, the Don Juan literature has found in the present century a new field in the sphere of romance and poetry in Spain and France; while in England the name of Don Juan was adopted by Byron as a congenial title for his famous poem. The two characters of Faust and Don Juan are blended in one and the same personage in a German drama by Grabbe, while a great number of plays, novels, and translations from the Spanish on Don Juan abound among German books of the present day.

**DONNE, John**, an English poet, born in London in 1573, died there, March 31, 1631. He was of a Roman Catholic family, studied at Oxford and Cambridge, and was designed for the law, but relinquished it in his 19th year for theology. He abandoned the Roman Catholic church for the Anglican, and travelled for three years in Spain and Italy. On his return to England in 1597 he was appointed secretary to Sir Thomas Egerton, keeper of the great seal, which post he held five years; but having secretly married Anne, daughter of Sir George More, and niece of Lady Egerton, he was dismissed from his situation and for a time imprisoned in the tower. He accompanied Sir

Robert Drury to Paris, and returning to England was presented to James I., by whose command he wrote the "Pseudo-Martyr" to prove that Roman Catholics might conscientiously take the oath of allegiance. At the age of about 41 he entered into orders, and having distinguished himself as a preacher he was made by the king his chaplain in ordinary and dean of St. Paul's, and received from the university of Cambridge the degree of doctor of divinity. His failing health obliged him to desist from preaching, but a calumnious whisper having reached him that his sickness was feigned because he chose to be idle, he ascended the pulpit and preached what his biographer has called his own funeral sermon, which was afterward printed with the title of "Death's Duel." He died soon after. He left sermons and devotional and controversial works, but is best known as a poet. His poems consist of satires, elegies, epigrams, and religious and complimentary verses. His subtle and vivid imagination, and his great simplicity and tenderness, are manifest amid his vast learning and the abounding vicious conceits of his style. He was the first of the series of English poets characterized by Dr. Johnson as metaphysical. His rugged numbers made him little esteemed during the last century, but the scattered gems of poetry and melody in his books have recalled something of his first reputation, and his works have been republished under the editorial care of Dean Alford (6 vols. 8vo, London, 1839). His life was written by Izaak Walton.

**DONNYBROOK**, or **St. Mary's of Donnybrook**, a parish and village of Ireland, county Dublin. The parish contains the villages of Irishtown, Donnybrook, Merrion, Ringsend, and Sandymount. The village (pop. about 2,000), two miles S. E. of Dublin, of which it is a suburb, is situated on the Dodder, here crossed by a handsome bridge, and contains a fine church, a spacious Roman Catholic chapel, a Magdalen asylum, a dispensary, a lunatic asylum, classical and other schools, a hat manufactory, and a number of mills. It is celebrated for its fair, granted by King John, and formerly held during 15 days from Aug. 26, afterward lasting only a week, being merely a pleasure fair. It was originally for the sale of horses and cattle, but became notorious for riot, bloodshed, and debauchery. It was abolished in 1855.

**DONOSO CORTÉS**, **Juan Francisco Maria de la Salud**, marquis de Valdegamas, a Spanish statesman and author, born at Valle de la Sarena, in Estremadura, May 6, 1809, died in Paris, May 3, 1853. At the age of 12 he entered upon a course of law at the university of Salamanca. He was prepared to receive his degree at the age of 16, but the rules not permitting it until the age of 25, he went to Seville, and employed the intervening years in the study of philosophy, history, and literature. During the divisions which took place in Spain in 1832, with regard to the right of succession to the throne, Donoso presented a memoir to

Ferdinand VII., in which he pleaded the liberal cause. The king rewarded him with a place in the ministry of justice. After the death of Ferdinand he defended the cause of Queen Isabella and her mother. He was elected to the cortes, and afterward appointed secretary to the ministerial council. Differing from Mendizabal, who was at its head, he resigned his post, and devoted himself to the tribune and the press. He was for some time the editor of the *Revista*, and a leading contributor to the *Piloto*, a newspaper founded by himself. During the dictatorship of Espartero he defended the interests of Maria Christina. In this contest he was vanquished, and shared the exile of the queen mother to France as her private secretary, and also accompanied her on her return to Spain in 1843. He was afterward appointed secretary to Queen Isabella, and minister plenipotentiary to the court of Berlin. In his speech in the cortes, Jan. 4, 1849, he renounced so-called liberal ideas, which he designated as sterile and disastrous to human society, whose peace had been disturbed by them for three centuries. At the time of his death he was minister at Paris. A work of his in French, entitled *Essai sur le Catholicisme, le libéralisme et le socialisme* (Paris, 1851), maintains that theology is the proper basis of politics. Among his writings are: *Consideraciones sobre la diplomacia, y su influencia en el estado politico y social de Europa* (Madrid, 1834); *La ley electoral, considerada en su base y en su relacion con el espíritu de nuestras instituciones* (1835); and a collection of his speeches and early writings (1849-'50). A complete French edition of his works appeared in Paris in 1859.

**DONOVAN**, **Edward**, an English naturalist, died Feb. 1, 1837. His first publication was a "Natural History of British Insects" (16 vols. royal 8vo, London, 1792-1816); of a similar character to which were his "Natural History of British Birds" (10 vols., 1794-1818), "Fishes" (5 vols., 1802-'8), "Shells" (5 vols., 1803-'4), and "Quadrupeds" (3 vols., 1820). In 1798 he published an "Epitome of the Natural History of the Insects of China," which was followed by works on the insects of India (1800), and of islands in the Indian and South Pacific oceans (1805). He also wrote a little book of instructions concerning the collection and preservation of subjects of natural history. His later works were a narrative of "Excursions through South Wales and Monmouthshire" (2 vols., 1805), a periodical entitled "The Naturalist's Repository," and an "Essay on the Minute Parts of Plants."

**DOO**, **George Thomas**, an English engraver and painter, born in the parish of Christchurch, Surrey, Jan. 6, 1800. He produced his first published engraving, "The Duke of York," after a painting by Sir Thomas Lawrence, in 1824. In 1825 he went to Paris and worked in the studio of Suisse, and studied the manner of Gros. He lectured on engraving at

Kensington museum and Harrow, and also on ancient Greek painting, and on the revival of art in the 12th century. He was elected a fellow of the royal society in 1851, associate engraver of the royal academy in 1855, and a royal academician in 1856. He is best known by his engraving of "Knox preaching before the Lords of the Congregation," after Wilkie; his "Combat," after Etty; "Italian Pilgrims coming in sight of Rome," after Eastlake; the "Infant Christ," after Raphael; and the "Ecce Homo," after Correggio. His engraving of the "Raising of Lazarus," by Sebastiano del Piombo (1864), occupied him eight years. In 1867 he exhibited "St. Augustine and Monica," after Ary Scheffer. Of late years he has engraved very little, and has devoted himself to painting portraits in oil.

**DOOLY**, a S. W. county of Georgia, with a level surface, watered by many small creeks, bounded W. by Flint river; area, 530 sq. m.; pop. in 1870, 9,790, of whom 4,855 were colored. Pine forests occupy much of the land, but the soil is fertile. The chief productions in 1870 were 149,987 bushels of Indian corn, 9,485 of oats, 20,881 of sweet potatoes, 4,132 bales of cotton, and 16,349 gallons of molasses. There were 657 horses, 1,636 milch cows, 3,857 other cattle, 5,592 sheep, and 10,104 swine. Capital, Vienna.

**DOON**, a lake and river of Scotland, in Ayrshire. Loch Doon is about 6 m. in length, and at no place exceeds three quarters of a mile in breadth. It is enclosed by the Star mountains of Kirkeudbright, abounds in trout, and has an islet on which stands an old castle, reputed to have been once the residence of Edward, brother of Robert Bruce. The river Doon issues from the lake, flows for about a mile through a wild ravine called Ness Glen, and after a N. W. course of 18 m. falls into the frith of Clyde, 2 m. S. of Ayr. About a mile from the sea, close by the river, stands a monument to Burns.

**DOOR**, a N. E. county of Wisconsin, consisting of a narrow peninsula between Green bay and Lake Michigan; area, 625 sq. m.; pop. in 1870, 4,919. The chief productions in 1870 were 34,585 bushels of wheat, 22,103 of oats, 43,157 of potatoes, 1,835 tons of hay, and 56,861 lbs. of butter. The total value of live stock was \$103,639. Capital, Gibraltar.

**DORA D'ISTRIA**, the pseudonyme of HELEN GHIKA, Princess Koltzoff-Massalsky, a Wallachian authoress, born in Bucharest, Jan. 22, 1829. She is great-granddaughter of Michael Ghika, who was assassinated by the Turks, and niece of Prince Alexander Ghika, hospodar of Wallachia. She received instruction from Professor Pappadopoulos, and early acquired a knowledge of the ancient and modern languages. When 15 years old she translated the Iliad into German, and afterward wrote several plays. She travelled in Europe from 1841 to the close of 1848, and on her return to Wallachia married in February, 1849,

the Russian prince Koltzoff-Massalsky, with whom she went to Russia. From 1855 to 1860 she resided in Switzerland and Belgium, and became known by her writings in the periodical press, as well as in published volumes. In 1860 she travelled in Greece, and in 1861 went to Italy, taking up her residence at Florence. In 1867 the Greek legislature adopted her as a Greek citizen. She is honorary member of several learned societies of Europe, and a Smyrna association elected her president in 1871. Besides her literary works, she has been a successful painter, and two landscapes exhibited in St. Petersburg in 1854 received a silver medal. Among her published works are: *La vie monastique dans l'Eglise orientale* (Brussels, 1855; Paris and Geneva, 1858); *La Suisse allemande et l'ascension du Mönch* (Paris and Geneva, 1856; English translation, London, 1858; German, Zürich, 1857-'9); *Les femmes en Orient* (Zürich, 1860; Russian and Greek translations, St. Petersburg and Athens); *Excursions en Roumélie et en Morée* (Zürich, 1863); *La Vénitienne* (1864); *Des femmes, par une femme* (Paris and Brussels, 1864; translated into Russian, Italian, and English); and *Gli Albanesi in Rumenia* (2 vols., 1873). She is also the author of several novels, and of pamphlets on philological subjects.

**DORAK**, a town of Persia, in the province of Khuzistan, situated at the junction of a small river of the same name with the Jerahi, about 30 m. from where the latter empties into the Persian gulf, and about 90 m. S. of Shuster; pop. variously estimated from 6,000 to 12,000. It stands upon a marshy plain, and is defended by mud walls and a fort, and surrounded by date plantations. There is a palace of the governor built of brick, which has long been falling into decay. There are manufactures of Arabian fabrics and garments, and a considerable commerce by means of the canal connecting the Dorak and the Karun, and exports to all parts of Persia and Arabia.

**DORAN, John**, a British author, born at Drogheda, Ireland, in 1807. He resided many years in France and Germany, took the degree of Ph. D. at the university of Marburg, and afterward went to England, became editor of various periodicals, and performed much general literary labor. He is now (1874) editor of "Notes and Queries." His principal works are: "Table Traits, and Something on them" (1854); "Habits and Men" and "Lives of the Queens of the House of Hanover" (1855); "Knights and their Days" (1856); "Monarchs retired from Business" (1857); "History of Court Fools" (1858); "New Pictures and Old Panels" and "The Last Journals of Horace Walpole" (1859); "Lives of the Princesses of Wales" (1860); "The Bentley Ballads" (1861); "Their Majesties' Servants" (1863); "Saints and Sinners" (1868); and "A Lady of the Last Century [Mrs. Elizabeth Montagu], illustrated in her Unpublished Letters, with a Biographical Sketch, and a Chapter on Blue Stockings" (1873).

**DORCHESTER**, a S. E. county of Maryland, bordering on Delaware and on Chesapeake bay, bounded N. and N. W. by Choptank river, and S. E. by the Nanticoke, both of which are here navigable; area, 640 sq. m.; pop. in 1870, 19,458, of whom 7,556 were colored. It has a level and partly marshy surface, with a soil sandy in some places and clayey in others. The Dorchester and Delaware railroad passes through it. The chief productions in 1870 were 122,460 bushels of wheat, 311,039 of Indian corn, 35,100 of oats, 65,949 lbs. of butter, and 15,368 of wool. There were 1,678 horses, 2,379 milch cows, 5,303 other cattle, 4,401 sheep, and 8,433 swine; 2 saw mills, 2 boat-building establishments, and 3 establishments for canning and preserving fruits. Capital, Cambridge.

**DORCHESTER**, formerly a town of Norfolk co., Mass., on Dorchester bay, an arm of Boston harbor, contiguous to South Boston, since 1869 constituting the 16th ward of the city of Boston; pop. of the town in 1860, 9,769; of the ward in 1870, 12,259. It was first settled by a party of English Puritans, headed by the Rev. John White of Dorchester, England, who landed at Nantasket, June 11, 1630, and established themselves within the limits of the town on the 17th of the same month. They soon erected a church, but no trace of it now remains. The first water mill in America was built here in 1633, and Dorchester has the honor of having originated about the same time the New England cod fishery.

**DORCHESTER** (anc. *Durnovaria*), a municipal and parliamentary borough of England, capital of Dorsetshire, near the river Frome, 113 m. S. W. of London; pop. in 1871, 6,915. It contains three churches, several dissenting chapels, schools and charitable institutions, a theatre, large cavalry barracks, and a county museum. It has considerable trade in beer, butter, sheep, and lambs. The Romans surrounded it with a wall. Athelstan made it the seat of two mints, and during the civil war it witnessed many severe battles. After the duke of Monmouth's rebellion in 1685, the assizes were held here by Jeffreys, who sentenced 109 of the insurgents to death, 13 of whom were executed. In the vicinity are the remains of a Roman amphitheatre with seats for 13,000 spectators, and a camp, and of a British station called Maiden castle.

**DORDOGNE**, a S. W. department of France, bordering on the departments of Haute-Vienne, Corrèze, Lot, Lot-et-Garonne, Gironde, Charente-Inférieure, and Charente; area, 3,545 sq. m.; pop. in 1872, 480,140. It was formed from the old province of Périgord and parts of Agenois, Angoumois, and Limousin. A large part of the land is occupied by marshes; nearly two thirds are considered unfit for cultivation, but the department is very rich in minerals. Iron, copper, lead, coal, manganese, lithographic stones, and marble are found in large quantities. The surface is hilly, and

covered in many places with extensive forests. Chestnuts are abundant, and are cultivated to a considerable extent. Game is plentiful, but cattle, owing to the poorness of the pasture lands, are raised in very small numbers. Red and white wines of good quality are produced; the crops of grain are fair, and the truffles of Dordogne are esteemed the best in France. The principal manufactures are iron, paper, brandy, and liqueurs. The largest rivers are the Dordogne (which rises in Auvergne, flows S. W. and W. through the departments of Corrèze, Dordogne, and Gironde, and with the Garonne forms the Gironde) and its tributary the Vézère, both of which are navigable. The department is divided into the arrondissements of Périgueux, Sarlat, Nontron, Bergerac, and Ribérac. Capital, Périgueux.

**DORÉ**, Paul Gustave, a French artist, born in Strasburg, Jan. 10, 1833. He early showed a passion for drawing, and his father sent him to the lycéums of Strasburg and Bourg. When only 11 years of age he published his first lithographs. The next year he was brought to Paris, and entered the Charlemagne lyceum, and in 1848 he published his first series of sketches, the "Labors of Hercules," in the *Journal pour rire*, for which paper he drew regularly from this time. In 1854 he illustrated the works of Rabelais. He drew many of the illustrations for the *Journal pour tous* from its foundation in 1856, and in that year illustrated Balzac's *Contes drolatiques* and the legend of the wandering Jew. Among the most prominent of the numerous works he has since illustrated are Montaigne (1857), Taine's *Voyage aux Pyrénées* (1859), Dante (1861-'8), Chateaubriand's *Atala* (1862), "Don Quixote" (1863), Milton's "Paradise Lost" (1865), the Bible (1865-'6), Tennyson's "Idyls of the King" (1866-'8), and La Fontaine's fables (1867). In 1853 he began to exhibit oil paintings, including "Two Mothers," "Alsatian Women," "A Mountebank who has stolen a Child," and some landscapes. The most noted of his pictures are scenes from Dante, especially his "Paolo and Francesca di Rimini," the battles of the Alma and Inkermann, the "Rebel Angels cast down" (1866), the "Gambling Hall at Baden-Baden," the "Neophyte" (1868), the "Triumph of Christianity," and "Christ leaving the Prætorium," which last measures 30 ft. by 20. It is said that he has executed over 45,000 designs.

**DORIA**, Andrea, a Genoese statesman and admiral, born at Oneglia, Nov. 30, 1468, died in Genoa in November, 1560. He belonged to a family celebrated for the great number of distinguished men it had produced since the 12th century. The influence which this family and those of the Fieschi, the Grimaldi, and the Spinolas exerted upon the destinies of Genoa was so powerful that the four families were called *Magna quatuor Prosapia*, the Dorias and the Spinolas siding with the Ghibelline party, and the other two with the Guelphs. The Dorias

boasted of many high functionaries and four distinguished admirals before the 14th century. Their fame, however, was eclipsed by that of Andrea, who in early life was successively employed in the service of Pope Innocent VIII., of the duke of Urbino, and of Ferdinand and Alfonso II. of Naples; and having passed some time in the Holy Land, he distinguished himself after his return to Italy by his exploits against Gonsalvo de Cordova and the Corsicans. In 1513 he was placed at the head of the navy of Genoa, and soon displayed his remarkable naval abilities, especially by clearing the waters of Genoa of pirates. When political troubles induced him to remove to Monaco, he showed as much public zeal in his retirement as he had while in power, and fitted out at his own expense 12 galleys which he had taken from the corsairs. In the war between Francis I. and Charles V. he accepted the command of the French galleys. After defeating the imperial fleet at Marseilles in 1524, and rendering various other signal services to the cause of France, he took umbrage at the attempt of Francis to injure Genoa by setting up a rival for her in fortifying the city of Savona, and, displeased at the same time with the personal treatment to which he was subjected, he left the French service to join that of Charles V., with whom he stipulated for the freedom of Genoa as the price of his services. By going over to the Spanish-Austrian party he paralyzed the progress of the French in Italy, and expelled them from Genoa (1528). Doria was now invested with the supreme power of Genoa, although he declined the dignity of doge, as this would have prevented him from remaining in the service of Charles V. The senate conferred upon him the name of "the father of peace," and ordered a statue to be erected to him and a palace to be placed at his disposal. He inaugurated a new form of government, making the office of doge biennial instead of for life, terminated the fatal dissensions between the Adorni and Fregosi, and recalled the banished members of the Genoese aristocracy, without however granting them any privileges over the other classes of society. While restoring order and governing the affairs of the republic, he continued to render himself useful to Charles V., who appointed him commander-in-chief of his navy, gave him the principality of Melfi, and raised the number of his galleys to 22. In 1532 he took from the Turks the towns of Coron and Patras in Greece. The conquest of Tunis in 1535 was mainly effected through his skill and bravery. In 1536 he took part in the invasion of Provence, captured Toulon, and carried the war to the gulf of Lyons. After the defeat of the imperial army by the French, he accompanied the emperor to Barcelona; and when a truce was concluded, the interview between Charles V. and Francis I. took place on board of one of Doria's galleys, this opportunity serving at the same time to effect a reconciliation between himself and his former master, the king

of France. In 1539 he neglected to avail himself of his superior force to defeat at Prevesa the Turkish fleet under Khair ed-Din (Barbarossa) of Algiers; and in 1541, during the fatal expedition of Charles to Algiers, he lost 11 of his galleys. Returning to Genoa, he applied himself for the rest of his life to the administration of the affairs of the republic, which was disturbed by the revolution instigated by the Fieschi family. In the outbreak of January, 1547, his nephew Gianettino Doria lost his life, which caused Andrea to punish the conspirators with great severity, and Fiesco himself was drowned accidentally. Doria's death, at the age of 92, was deplored by the Genoese as a national calamity.

**DORIANS**, the name by which one of the four chief branches of the Hellenes, the descendants of Dorus, son of Hellen, were distinguished in the history of ancient Greece. In the remotest period they appear on the classic ground between Mount Olympus and Ossa; then, by turns conquering and conquered, in Macedonia, on the island of Crete, in Doris, where they founded the Tetrapolis, and in the Peloponnese, which they entered under the returning Heraclidæ, and where they became masters of Sparta, Argos, and Messenia. They distinguished themselves from other Hellenic tribes by a character of dignified solidity, of rigid and often rough gravity. This manifested itself not only in their manners, laws, and institutions, so much in contrast with those of the milder Ionians, but also in their dialect, broad and rough, but strong and solemn, and therefore well suited to sacred hymns and choruses; in the light hunting dress of their women, in the strong and unadorned Doric column, in the warlike sounds of their music, and even in the spirit of the Pythagorean philosophy; while everything Ionian was marked by a character of softness, elegance, and taste. Colonies of the Dorians flourished in Italy, Sicily, and Asia Minor.—See K. O. Müller, *Die Dorer* (2d ed., 3 vols., Breslau, 1844).

**DORIS. I.** A district of Greece, now belonging to the nomarchy of Phliliotis and Phocis, a small mountainous region, watered by the Pindus; anciently one of the smallest divisions of Hellas, inhabited by the Dorians, and bounded by Thessaly, Phocis, Locris, and Ætolia. Of its four confederate cities, the so-called Tetrapolis, built at the foot of Mount Ceta, none was adorned by great names or events. They were soon destroyed by hostile neighbors and were in ruins in the time of the Romans. **II.** In Asia Minor, a portion of the coast of Caria, settled by Dorians. It formed a part of a confederacy originally consisting of six cities, most of them on the neighboring islands, and known as the Dorian hexapolis, which, though dependent at every period of history on some larger state, had a place of national assembly on the promontory of Triopium, where festivals and games were celebrated, and common affairs discussed. Halicarnassus and Cnidus were the

most important towns; the former, however, was early excluded from the league, which from a hexapolis thus became a pentapolis.

**DORKING**, a market town and parish of Surrey, England, situated in a beautiful valley on the left bank of the Mole, 20 m. S. S. W. of London; pop. about 4,000. It is noted for its romantic scenery. The Dorking fowls, celebrated for their excellent qualities, are supposed to have been introduced here by the Romans. They are usually white or of a partridge color, and have five claws on each foot. The neighboring country contains many beautiful residences, among which are Deepdene, the seat of the late Thomas Hope, and the Rookery, where Malthus was born.

**DORMOUSE**, a small rodent of the jerboa family, belonging to the genus *myoxus* (Gmelin); this genus has since been subdivided, with the addition of the genera *muscardinus* (Ray) and *graphiurus* (F. Cuv.). The genus *myoxus* has two incisors above and below, and four molars on each side of each jaw divided by numerous transverse bands; the eyes are

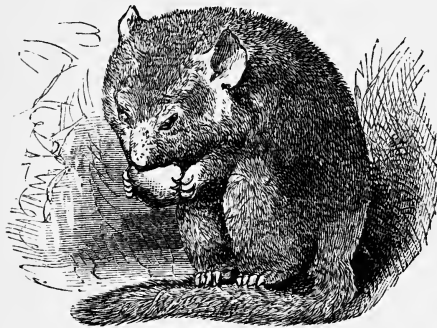

Dormouse (*Muscardinus avellanarius*).

large and prominent; the ears large; the whiskers long; no cheek pouches; fore feet with four toes and the rudiment of a fifth; hind feet five-toed; tail long and hairy; fur soft; claws sharp. Dormice live principally on trees, eating fruits, and pass the winter in a state of lethargy, having collected a store of food for use in the spring. All are said by Cuvier to be destitute of a cæcum. The largest known species are all European. The largest, the fat dormouse or loir (*M. glis*, Linn.), is about 6 in. long, of an ashy brown above, whitish below, with brown about the eyes; the whiskers are strong; the tail is much like that of a squirrel. It resembles the squirrel in its manners, though it is less active, climbing trees with facility, and rarely descending to the ground; it makes a nest of moss in hollow trees, couples in the spring, and brings forth four or five at a birth; it is confined to the south of Europe, and in Italy has from remote times been used as food. As cold weather approaches, the dormouse rolls itself into a ball, and in this state is found in winter in holes of

trees and clefts of rocks; if kept in a warm room during winter, it continues active like ordinary animals; when the thermometer descends to about 48° F. it begins to grow torpid, and becomes entirely so at about 42°; according to the experiments of M. Mangili of Pavia, a temperature of 32°, or lower, revives the animal. When torpid, it appears as if dead, with the eyes closed, the breathing being suspended for a period of from 5 to 20 minutes, and then renewed for from 15 to 30 respirations, with a corresponding retardation of the circulation. The garden dormouse, or lerot (*M. quereinus*, Linn.), is smaller, with a thicker body, more pointed muzzle, and more thinly haired tail; the color is reddish gray above and white below, black round the eyes to the shoulders, tail black with a white tuft. This species lives in gardens, and sometimes enters houses; it often does mischief in orchards, always selecting the choicest fruit; it hibernates, eight or ten being sometimes found together rolled up in a magazine of food; the scent is like that of the rat, and the flesh is not used as food; it is confined to temperate Europe. The common dormouse (*muscardinus avellanarius*, Linn.) is not much larger than a mouse, but the head is shorter, the muzzle less pointed, and the eyes larger; the color above is a cinnamon red, and below whitish; the tail, as long as the body and flattened horizontally, is covered with hair, quite short, and arranged on each side like the barbs of a feather. This species inhabits the woods, hibernating in the clefts of trees, and is rarely found in gardens or houses. The name dormouse, or sleeping mouse, is best applied to this species, as it most readily falls into the lethargic state, from which it is aroused either by a too high or a too low temperature, becoming active in less than half an hour; when awakened, like the other species, it partakes moderately of food. It is found in temperate Europe, occasionally in England. The Cape dormouse (*graphiurus capensis*, F. Cuv.) is found in South Africa; the length is 7½ in. of which the tail is 3½; the color is bluish gray above and whitish below; the muzzle and spots above and behind the ear white, behind the chin rufous; tail bushy and penniform, grayish above and blackish below. —Dormice are kept as pets, and may be fed on all kinds of grain and nuts; the inner part of the cage should be stuffed with fine hay, and the whole kept very clean; in winter they should be kept in a warm room to prevent their going to sleep.

**DORN**, *Heinrich Ludwig Edmund*, a German composer, born in Königsberg, Nov. 14, 1804. He was leader of orchestras in that city, in Leipsic, and in Riga, till 1843, when he became director of a musical association in Cologne. Since 1849 he has been in Berlin as leader of the court orchestra. Among his works are the operas *Der Schiffe von Paris* and *Die Nibelungen*. In 1870 he published an autobiography, entitled *Aus meinem Leben*.

**DORNBIRN**, a town of Vorarlberg, Austria, 6 m. S. of Bregenz; pop. in 1870, 8,486. It has a flourishing industry, chiefly consisting of the construction of wooden houses, which are exported, and of manufactures of cotton goods and embroidery. It was formerly an imperial village.

**DORNER, Isaak August**, a German theologian, born near Tuttlingen, Würtemberg, June 20, 1809. He is the son of a Lutheran clergyman, studied at Tübingen, and became a professor there in 1838. He removed in the following year to the university of Kiel, which he left very soon on his appointment as professor of divinity and councillor of the consistory at Königsberg. In 1847 he accepted a chair at Bonn, which he held till 1853, when he removed to Göttingen; and since 1862 he has been professor of systematic theology and exegesis at the university of Berlin. As a theological writer he is best known by his *Entwicklungsgeschichte der Lehre von der Person Christi* (Stuttgart, 1839; English translation by Dr. W. Simon, Edinburgh, 1859); and for his contributions to Herzog's *Encyclopädie für protestantische Theologie*, and to the *Jahrbücher für deutsche Theologie*, of which he is joint editor with Liebner and Ehrenfeuchter. Among his recent publications are *Geschichte der protestantischen Theologie* (Leipsic, 1867; translated into English, Edinburgh, 1871), and *Ueber die einheitliche Textgestaltung, beziehungsweise Verbesserung der lutherischen Uebersetzung des Neuen Testaments* (Stuttgart, 1868).

**DOROG**, the name of several towns of Hungary, the most important of which is situated in the circle beyond the Theiss, 20 m. N. N. W. of Debreczin, and belongs to the Hayduk district; pop. in 1870, 6,872. It is surrounded by marshy tracts of great fertility, but deficient in wood, and is an important market for grain, cattle, and horses. It contains a Greek non-united and a Roman Catholic parish church.

**DOROGOBUZH**, a town of Russia, capital of a district in the government and 55 m. E. N. E. of the city of Smolensk, on the Dnieper; pop. in 1867, 8,467. An encounter took place here, Oct. 27, 1812, between the rear guard of the retreating French and the Russians. The French partly burned the town.

**DOROSMA**, a town of Hungary, in the district of Little Cumania, 6 m. W. by N. of Szegedin; pop. in 1870, 9,688. It contains a Roman Catholic high school.

**DORP**, a town of Prussia, in the province of the Rhine, situated on the Wupper, 17 m. N. E. of Cologne; pop. in 1871, 10,690. It has considerable manufactures of tobacco, paper, steel, and hardware; and is growing rapidly.

**DORPAT, Dörpt**, or **Derpt**, a town of Russia, in Livonia, situated on the Embach, which is here crossed by a granite bridge, 163 m. S. W. of St. Petersburg; pop. in 1867, 20,780. It is on the road from Riga to St. Petersburg, and has two suburbs bearing the names of those

cities. It has a neat and picturesque appearance, being ranged in a semicircle, with clean, well paved streets, and a spacious market place. The most noteworthy of the public buildings is the university, founded in 1632, when the town belonged to Sweden, by Gustavus Adolphus, suppressed by the Russians in 1656, and reestablished in 1802 by the emperor Alexander. Connected with it are a normal school called the *Professoren-Institut*, founded in 1828, and an observatory which the labors of Struve and other astronomers have rendered famous. The university has a library of about 80,000 volumes, a museum, and a botanical garden. It is in high repute, and students (600 to 700) resort to it from every part of the empire. The rector of the university is now appointed by the emperor; previous to 1851 he was selected by the professors from their own body. Dorpat also contains a gymnasium, founded in 1589, a number of other schools and academies, handsome law courts, and an ancient cathedral, now partly in ruins. The town was once fortified, but the defences have been dismantled and converted into pleasure gardens. It was founded in the 11th century, and anciently possessed great commercial importance, ranking as one of the Hanse towns. The Teutonic knights took it from the Russians in 1223, and erected it into a bishopric in 1224. This rendered it a place of considerable note, and for upward of three centuries the bishop exercised almost sovereign power within his diocese. The see was abolished in 1558, when the town passed again into the hands of the Russians. The Poles seized it in 1582, and the Swedes took it from them in 1625. Peter the Great recaptured it in 1704, and it has remained ever since in the possession of Russia. The vernacular is Esthonian, but the best educated classes speak German, which is also the language of the university and of the gymnasium.

**DORSET, Earls of.** See SACKVILLE.

**DORSETSHIRE**, a maritime county of England, on the British channel, and bordering on Devonshire, Somersetshire, Wilts, and Hants; length from E. to W. 57 m., greatest breadth 40 m.; area, 1,006 sq. m.; pop. in 1871, 195,544. The seacoast is very irregular, running out in several promontories, and broken by Poole harbor and Weymouth or Melcombe Regis bay. The chief rivers are the Stour, Frome, and Piddle. The face of the country is undulating, there being no mountains, and the highest point, Pillerden Pen, being only 934 ft. above the sea. A range of chalk downs, entering the country from Wiltshire on the N., passes S. W. and W. to the border of Somersetshire on the W., and is called the North downs; while a similar range, under the name of South downs, runs S. and S. E. from the W. terminus of the other, nearly parallel with the coast, to Poole harbor. The soil consists mainly of loose sand or gravel, interspersed with clay and chalk, and in some places mixed with them,

the conglomerate thus produced being the most fertile in the county. Besides the chalk formation, Dorsetshire contains pipe, plastic, and potters' clays, and has famous quarries of Portland stone, so called from the locality in which it is found, and which is exported to various parts of England, Ireland, and France. There are no ores nor coal. The downs are employed chiefly as sheep pastures. The Dorset sheep are noted as a profitable breed, and "Southdown mutton" has a high reputation. There is another and very small breed in the island of Purbeck, much prized by epicures. Excellent butter is made, but the cheese is of poor quality. The principal grain crops are wheat and barley. Potatoes, flax, and hemp are also raised. The manufactures comprise silk, woollens, cottons, blankets, canvas, ducks, fabrics of flax, gloves, parchment, buttons, beer, ale, and cider. Herrings, salmon, oysters, and large quantities of mackerel are taken off the coast. The chief towns are Dorchester, the county seat, Bridport, Lyme Regis, Weymouth, Poole, Shaftesbury, Wareham, and Sherborne.

**DORSEY, John Syng**, an American physician, born in Philadelphia, Dec. 23, 1783, died Nov. 12, 1818. He studied medicine with his relative Dr. Physick, received the degree of M. D. in 1802, visited France and England, and returned home in December, 1804. He was elected adjunct professor of surgery in the Philadelphia medical school in 1807, was transferred to the chair of *materia medica*, and having given two courses of lectures on that subject, was chosen to succeed Dr. Wistar as professor of anatomy. On the evening after delivering his introductory lecture he was attacked by a fever, and died at the end of a week, having gained at the age of 35 the reputation of one of the first surgeons of America. He contributed valuable papers to several periodicals, and published "Elements of Surgery" (2 vols. 8vo, 1813), adopted as a text book in the university of Edinburgh.

**DORSIBRANCHIATES**, a division of worms, swimming free in the sea, or living in the mud and sand, whose organs of respiration are in the form of tufts or branchial appendages arranged along the back or sides. The lob-worm (*arenicola piscatorum*), so much prized as bait in Europe, attains the size of the finger, and species of *eunice* have been found 4 ft. long.

**DORT**, or **Dordrecht** (Lat. *Dordracum*), an ancient town of the Netherlands, in the province of South Holland, situated on an island in the Merwede, a river formed by the junction of the Maas and the Waal, 11 m. S. E. of Rotterdam; pop. in 1870, 25,359. The advantages of its position, near the sea, accessible from the Rhine through the Waal, and having easy communication with an extensive inland district, have rendered it one of the first commercial towns of Holland. From Liège it receives coal, lime, and millstones. The vineyards on the Rhine supply it with wine, and from Switz-

erland and upper Germany it obtains timber, which drifts down the river in large rafts like floating islands, and is here collected. The surrounding waters afford plenty of good fish and wild fowl. A flourishing trade is carried on in oil, seeds, grain, flax, and stock fish. There are oil mills, saw mills, salt and sugar refineries, bleaching grounds, and factories of white lead, tobacco, steel pens, and window glass. The port is excellent. There are canals leading to the interior of the town, and a number of quays. The houses have an exceedingly antiquated appearance; the windows are grotesquely ornamented, and the gable ends generally face the street. Three old houses formerly used as rendezvous for armed burghers are still standing. In one of these, now used as a play house, was held the famous Protestant synod of Dort in 1618-'19, which condemned the doctrines of Arminius; and the provincial synods of South Holland were held in the same place until 1731, after which they convened in the great church. Another has been converted into a court house, and a public school is taught in the third. The chief church is St. Mary's, an immense building of great antiquity, now used by the Protestants, but originally by the Roman Catholics, and then containing 20 chapels and 40 altars. The pulpit is a fine piece of workmanship, of white marble elaborately sculptured. The town hall is very old, but in good preservation. Dort also has a corn exchange, a bank, an artillery arsenal, classical, agricultural, and other schools, an orphan asylum, almshouses, an infirmary, and a lunatic asylum. In 1421 it was involved in a terrible inundation, which is said to have swallowed up 70 villages, and to which the island of Dort owes its formation, the city having previously stood on the mainland. A conflagration in 1457 consumed upward of 2,000 houses, including many public edifices. The first meeting of the states general, at which the independence of the United Provinces was declared, was held here in 1572. While the disputes about the stadtholdership were raging in 1672, the inhabitants of this town sided with the house of Orange; in 1786-'7, when similar difficulties arose, and Prussia intervened, Dort took a decided stand against that kingdom, and succeeded in obtaining advantageous terms.

**DORT, Synod of.** See REFORMED PROTESTANT DUTCH CHURCH.

**DORTMUND**, a town of Prussia, in the province of Westphalia, 31 m. S. by W. of Münster; pop. in 1871, 44,454. It is enclosed by walls, has five gates, several churches, two hospitals, and some other public buildings, manufactories of woollen, linen, cotton, &c., four annual fairs, and a considerable trade. It was important at an early day, and was a member of the Hanseatic league, but its prosperity afterward declined. Formerly a free imperial city, it passed to the family of Nassau-Diez in 1802, and into the hands of Prussia in 1815.



**DORUS-GRAS**, Julie Aimée van Steenkiste, a French soprano singer, born in Valenciennes in 1813. She was engaged at the grand opera of Paris in 1830, and remained there upward of 20 years, when she retired with her husband M. Gras, a violinist. Her chief parts were in *Guillaume Tell*, *La muette de Portici*, *Fernand Cortez*, *Robert le Diable*, *Les Huguenots*, and *La Juive*. Her voice had great compass and flexibility, and she was distinguished by brilliancy of execution and dramatic delivery.

**DORY**, the name of a family of scomberoid fishes, distinguished from the others of the group by having protractile mouths. This family of *zeida* contains the six genera of *zeus* (Linn.), *capros* (Lacép.), *caprophonus* (Müll. and Trosch.), *lampris* (Risso), *equula* (Cuv.), and *mene* (Lacép.) The name of dory is generally restricted to the genus *zeus* (Linn.), characterized by one dorsal fin deeply notched, or two contiguous dorsals of which the anterior is spinous, with delicate filaments projecting far beyond the spines; the ventrals, also spiny, are a little in advance of the pectorals; there are two anals, or two divisions of a single anal,

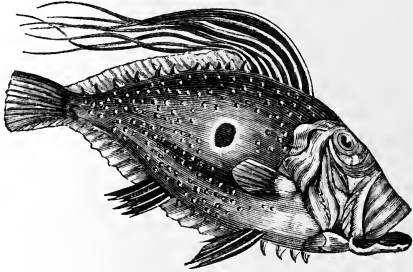

John Dory (*Zeus faber*).

the anterior portion being spinous and the posterior soft, like the dorsals; the caudal is distinct and rounded at the end; there are several bony dermal bifurcated plates or shields along the basis of the dorsal and anal fins; the branchiostegal rays are seven; the teeth numerous, small, and feeble; the stomach large and caecal, with very numerous pyloric caeca; air bladder large, simple, and oval. The best known species is the common or John dory (*Z. faber*, Linn.), a fish attaining a length of over 2 ft., of a grotesque form, and a yellowish tint; the body is smooth, oval, and much compressed; the mouth is large, and capable of such protrusion that the length from the point of the lower jaw to the posterior angle of the operculum may be made as great as from this angle to the base of the tail; the teeth are in a single row; the eyes are large, lateral, high up on the head, and with yellow irides; behind and over each eye is a spine. The general color is olive brown tinged with yellow, with blue, white, and golden reflections rapidly varying; on each side, very near the middle of the oval, is a round black spot surrounded by a narrow light ring. This fish was well

known to the ancients, who expressed their regard for it by giving it the name of Jupiter. It has received a number of popular names, among others that of "St. Peter's fish;" with the haddock it disputes the honor of having been the species out of whose mouth this apostle took the tribute money, bearing on its sides, according to one popular tradition, the black spots indicating the marks of his finger and thumb; another tradition assigns the origin of these spots to the similar touch of St. Christopher as he bore the Saviour, wading through an arm of the sea. The name of dory has been derived from the French *adorée* (worshipped), and *dorée* (golden); the prefix of John has been derived from the French *jaune* (yellow). From the resemblance of the first dorsal fin to a cock's comb, it has been called sea chicken, *gal*, *gallo*, and in Gascony *jau* (cock), to which also some have traced the epithet of John, the whole name meaning the "gilt cock of the sea." This species is found in the Mediterranean, along the western coast of Europe, at the Canary islands, and on the English and Irish coasts; in England it is most common on the coasts of Devonshire and Cornwall. Its forbidding appearance has prevented it from being so much prized as an article of food as it deserves; it was highly esteemed, however, by the ancient Romans, and is now a favorite in many parts of England. It is a deep-water fish, and feeds on the fry of other species, shrimps, and mollusks; the average weight in the London market is 3 or 4 lbs., but some from the bay of Biscay have been seen weighing 12 to 16 lbs. It often follows the pilchards, being very voracious, and is caught in the same nets with them; it readily takes the hook when baited with a living fish. In June, 1858, Dr. D. H. Storer described the first species of this genus found in American waters, in the "Proceedings of the Boston Society of Natural History" (vol. vi., p. 385); this is the spotted dory (*Z. ocellatus*, Storer), captured at Provincetown, Mass. The color is cupreous, marked with numerous dark circular spots; the base of the second dorsal is longer than that of the first; along the dorsal fin are seven bony spinous plates, along the anal five, along the abdomen eight, and along the throat four; the length was six inches.—The name of dory has been applied in this country to other scomberoid fishes of the genera *blepharis* (Cuv.), *argyreus* (Lacép.), and *vomer* (Cuv.); these were included by Linnæus and Bloch in the genus *zeus*, from which they were separated by Cuvier. These American dorics have a very compressed body and very singular forms. In the genus *blepharis* the body is sharp on the edges, with a brilliant smooth skin; the dorsal and anal fins have filamentous rays from 4 to 12 in. in length, which from their resemblance to wax ends have obtained for them in the West Indies the name of *cordonniers* (shoemakers). In the genus *argyreus* the second and third rays, or only the first, of one or both

dorsals are filamentous; the great perpendicularity of the facial line gives a ridiculously solemn expression to this genus; these fishes are occasionally taken in the waters of New York, and are considered excellent food. The genus *vomer* has a similar vertical profile and silvery lustre, but no filaments or prolongations of the fins; it is esteemed for food; the *V. Brownii* (Val.) of the New York coast is from 8 to 12 in. long.

**DOSITHEANS**, an ancient sect of the Samaritans, so called from their founder Dositheus, who was a companion of Simon Magus, and flourished in the 1st century A. D. According to one account, Dositheus was a disciple of John the Baptist, and, after the death of the latter, endeavored to place himself at the head of the followers of that prophet. Another account tells us that he tried to persuade the Samaritans to receive him as the Messiah. There were still in the 4th century a few Dositheans who adhered to their master as the true Messiah, but the sect was never important.

**DOST MOHAMMED.** See **AFGHANISTAN.**

**DOTIS**, or **Totis** (Hung. *Tata*), a town of Hungary, in the county and 12 m. S. E. of the town of Comorn, and 37 m. W. N. W. of Pesth; pop. in 1870, 9,855. It is in two parts, one on a hill, and the other on the shore of a little lake, separated by the ruins of a castle once the residence of King Matthias Corvinus. On the lake is the castle of Count Nicholas Esterházy, famous for its extensive wine vaults, in one of which is a tun of 34,700 gallons, which is generally full. The castle has a fine garden laid out in the English manner. There are several churches, a Piarist college with a gymnasium, a high school, and a military hospital. There are numerous mills and manufactories of woollens and stone ware, and a large market for sheep. Near the town are warm baths and mineral springs, valuable quarries, and Roman remains.

**DOUAI**, or **Douay**, a town of France, in the department of Le Nord, 18 m. S. of Lille; pop. in 1866, 24,105. It is situated on the river Scarpe, the canal de la Sensée, and the Northern railway. It is surrounded by walls, is strongly fortified, and contains several literary and scientific institutions, important educational establishments, among them a normal school, a public library, school of artillery, an arsenal and cannon foundry belonging to the government, and has manufactories of lace, embroidery, cotton, linen, leather, delft ware, glass, paper, refined sugar, salt, &c., several breweries, distilleries, and oil mills, and an extensive trade. Douai, according to some, existed under the Romans. It was important when in possession of the counts of Flanders, from whom it came into the power of the king of Spain, and in 1667 passed into the hands of Louis XIV. Taken by the duke of Marlborough in 1710, it was soon retaken by the French, and its possession was confirmed to them by the treaty of Utrecht in 1713. During

the religious troubles in England in the 16th and 17th centuries, it acquired considerable celebrity as the seat of a Roman Catholic college and ecclesiastical seminary, founded by Dr. William (afterward Cardinal) Allen, for the education of English youth. Studies were commenced at this institution in 1568, and for about ten years its prosperity was uninterrupted. But in course of time the townspeople of Douai, then subjects of the king of Spain, grew jealous of their English neighbors, and disturbances were frequent. To prevent further mischief the college was removed to Rheims in 1578, where it was protected by the Guise family. In 1593 it was again established at Douai, and remained there until broken up by the French revolution in 1793.

**DOUARNENEZ**, a town of France, in the department of Finistère, situated on a bay of the same name, 20 m. S. of Brest; pop. in 1866, 5,434. It has a considerable coasting trade and extensive fisheries.

**DOUAY. I. Charles Abel**, a French soldier, born in Besançon in 1809, killed at Weissenburg, Aug. 4, 1870. He was a graduate of the military academy of St. Cyr, served in Algeria and the Crimea, and distinguished himself in the attack on the Malakhoff. He was promoted to the rank of brigadier general in 1855, and in 1859 to that of general of division for his brilliant services in the battle of Solferino. In the Franco-German war he commanded the second division of the first army corps, and was entrenched on the height of Weissenburg with two brigades and three batteries, where his forces were overwhelmed and scattered by the Germans under the crown prince Frederick William. He exposed himself to the fire of the enemy, and was struck by several bullets, his corps being found on the battle field. **II. Félix Charles**, a French soldier, brother of the preceding, born in Besançon in 1818. He was at the siege of Rome as captain in 1849, and was lieutenant colonel in the Crimean war. After the battle of Magenta he became brigadier general, and he served as general of division under Forey in Mexico. In the Franco-German war he was commander-in-chief of the seventh army corps at Belfort, re-enforced MacMahon at Châlons, and became a prisoner of war at Sedan. On his return to France he commanded the fourth army corps in the struggle with the commune, and on May 6 he occupied Boulogne, and engaged in protracted conflicts with Dombrowski's forces. He was the first to enter Paris by the gate of St. Cloud, May 21, saved the Louvre from being totally destroyed by the communists, and took possession (May 27) of Belleville. Subsequently he was placed in command of the military district of the Rhône, with his headquarters at Lyons.

**DOUBLEDAY, Edward**, an English naturalist, born in 1810, died in London in 1849. At an early age he made a tour of the United States, and on his return published a paper on the

"Natural History of North America," and was appointed one of the curators of the British museum. The most valuable of his contributions to science are the results of his researches concerning butterflies, published in a work "On the Genera of Diurnal Lepidoptera," which he left unfinished. He was also the author of a variety of papers on ornithology, entomology, and zoology, published in the "Entomological Magazine" and elsewhere.

**DOUBLOON** (Sp. *doblon*), a gold coin of Spain and Spanish America, originally valued at \$16. Its subdivisions in gold were the half doubloon, the quarter or *pistole*, the eighth or *escudo*, and in Spain the sixteenth or *veinten*. It is still coined in Mexico, Central America, and most of the South American states, but owing to a reduction of fineness is worth only from \$15 37 to \$15 61. (See COINS.)

**DOUBS** (anc. *Dubis*), a river of France, the largest affluent of the Saône, and forming part of the navigable canal between the Rhône and the Rhine. It rises in Mount Rixou, one of the summits of the Jura, 3,000 ft. high, and after a tortuous course through the department which bears its name, flows S. W. through that of Jura and part of Saône-et-Loire, and joins the Saône near the village of Verdun. Its total length is about 280 m. Strong currents impede the navigation; at various points it forms small lakes, and it has a cataract, the Saut du Doubs, about 100 ft. high. Among its affluents are the Dessoubre and the Savoureuse.

**DOUBS**, an E. department of France, in the old province of Franche-Comté, bordering on Switzerland and on the departments of Haut-Rhin, Haute-Saône, and Jura; area, 2,018 sq. m.; pop. in 1872, 291,251. Its surface gradually rises from the more level country in the N. W. to the rugged and sterile peaks of the Jura range. The principal rivers are the Doubs and the Oignon, which divides it from Haute-Saône, but there is a large number of smaller streams. Agriculture is carried on to some extent, but the grain raised is insufficient for the home consumption. Much attention is paid to the raising of horses and cattle, and a considerable portion of the department is devoted to pasturage. There are some iron mines, which are worked, and coal, gypsum, building stone, and salt are also produced. The manufactures comprise clocks, paper, leather, woollen and cotton cloth, iron and steel ware, butter, cheese, &c. The climate is somewhat variable, but on the whole is cold, and in the lower parts much rain falls. The country is nevertheless healthful, and the inhabitants are vigorous and sturdy. It is divided into the arrondissements of Besançon, Montbéliard, Baume-les-Dames, and Pontarlier. Capital, Besançon.

**DOUCE, Francis**, an English antiquary, born in 1762, died in London, March 30, 1834. He collected a great number of rare books, prints, medals, coins, &c., the most important of which he bequeathed at his death to the Bodleian

library. He gave his papers to the British museum, on condition that the box which contained them should not be opened until the year 1900. He contributed some papers to the "Archæologia" and to the "Gentleman's Magazine," and was the author of "Illustrations of Shakespeare and Ancient Manners" (2 vols. 8vo, London, 1807), and a "Dissertation on the Dance of Death" (London, 1834).

**DOUGHERTY**, a S. W. county of Georgia, intersected by Flint river; area, 300 sq. m.; pop. in 1870, 11,517, of whom 9,424 were colored. The surface is level; the soil fertile. The Southwestern railroad and the Albany branch of the Atlantic and Gulf line cross it. The chief productions in 1870 were 228,223 bushels of Indian corn, 12,365 of oats, and 14,034 bales of cotton. There were 1,860 mules and asses, 1,168 milch cows, 2,095 other cattle, and 3,422 swine; 2 machine shops, 1 manufactory of sashes, doors, and blinds, and 1 flour mill. Capital, Albany.

**DOUGHTY, Thomas**, an American landscape painter, born in Philadelphia, July 19, 1793, died in New York, July 24, 1856. He was apprenticed to a leather manufacturer, and afterward carried on the business on his own account. He had attempted painting in oil, and had received a quarter's tuition in India ink drawing, when a growing taste for art induced him in his 28th year, contrary to the advice of his friends, to become a painter. He practised his profession for many years in the United States, and also in London and Paris, acquiring a considerable reputation by his paintings of American scenery.

**DOUGLAS**, the name of eleven counties in the United States. **I.** A N. W. county of Georgia, formed since the census of 1870, bounded S. E. by the Chattahoochee river; area, about 300 sq. m. The surface is hilly, and the soil fertile. Grain and cotton are the staple products. Various minerals abound. Capital, Douglasville. **II.** An E. county of Illinois, intersected by Kaskaskia and Embarras rivers; area, 375 sq. m.; pop. in 1870, 13,484. The surface is level, and the soil fertile. The Chicago division of the Illinois Central railroad traverses it. The chief productions in 1870 were 73,144 bushels of wheat, 1,680,225 of Indian corn, 225,074 of oats, 65,265 of potatoes, 15,201 tons of hay, 29,406 lbs. of wool, and 198,283 of butter. There were 5,681 horses, 3,207 milch cows, 8,670 other cattle, 10,553 sheep, and 17,433 swine. Capital, Tuscola. **III.** The N. W. county of Wisconsin, bordering on Lake Superior and Minnesota; area, 1,500 sq. m.; pop. in 1870, 1,122. It is watered by several streams. The surface is hilly and generally covered with forests. The soil of the river bottoms is fertile. A ridge, called Mineral range, which contains copper, crosses it. The Lake Superior and Mississippi railroad skirts the N. W. corner. The value of farms in 1870 was \$66,760. Capital, Superior City. **IV.** A W. county of Minnesota; area, 720 sq.

m.; pop. in 1870, 4,239. The surface is dotted with numerous small lakes. The proposed St. Paul and Pacific railroad is to pass through the county. The chief productions in 1870 were 59,375 bushels of wheat, 65,568 of oats, 6,570 of Indian corn, 36,884 of potatoes, 10,708 tons of hay, and 90,574 lbs. of butter. The total value of live stock was \$168,758. Capital, Alexandria. **V.** A S. county of Missouri, drained by the N. fork of White river; area, 600 sq. m.; pop. in 1870, 3,915, of whom 27 were colored. The surface is hilly and in parts covered with forests. Lead has been found. The chief productions in 1870 were 13,794 bushels of wheat, 102,975 of Indian corn, and 18,050 of oats. There were 1,289 horses, 2,916 cattle, 2,805 sheep, and 7,676 swine. Capital, Vera Cruz. **VI.** An E. county of Nebraska, bounded E. by the Missouri river, which separates it from Iowa, and W. by the Platte, drained by Elkhorn, Big Papillon, and Little Papillon rivers; area, 350 sq. m.; pop. in 1870, 19,982. The surface is undulating prairie, and the soil fertile. Limestone is common, and water power abundant. The Union Pacific, the Omaha and Northwestern, and the Omaha and Southwestern railroads traverse it. The chief productions in 1870 were 84,545 bushels of wheat, 208,820 of Indian corn, 89,766 of oats, 44,899 of potatoes, and 11,381 tons of hay. There were 1,595 horses, 1,509 milch cows, 2,081 other cattle, and 2,827 swine; 5 manufactories of boots and shoes, 2 of bricks, 1 of carriages and wagons, 3 of confectionery, 1 of gas, 2 of iron castings, 10 of jewelry, 6 of saddlery and harness, 9 of tin, copper, and sheet-iron ware, 9 of cigars, 1 distillery, 5 breweries, 4 railroad repair shops, and 4 flour mills. Capital, Omaha. **VII.** An E. county of Kansas, bounded N. by Kansas river, and drained by the Waukarusa; area, 470 sq. m.; pop. in 1870, 20,592. It consists chiefly of rolling uplands, with a black loamy soil, well timbered. The minerals are coal and carboniferous limestone. The Leavenworth, Lawrence, and Galveston, and the Lawrence and Pleasant Hill railroads traverse it. The chief productions in 1870 were 65,042 bushels of wheat, 1,065,113 of Indian corn, 415,129 of oats, 193,983 of potatoes, 19,482 tons of hay, and 293,376 lbs. of butter. There were 6,614 horses, 6,656 milch cows, 9,665 other cattle, and 14,504 swine; 2 manufactories of agricultural implements, 2 of boots and shoes, 9 of carriages and wagons, 1 of iron castings, 5 of saddlery and harness, 5 of tin, copper, and sheet-iron ware, 2 of woollen goods, 4 saw mills, and 6 flour mills. Capital, Lawrence. **VIII.** A S. W. county of Oregon, bounded E. by the Cascade mountains, N. W. by the Pacific, and drained by the Umpqua river and its branches; area, 5,000 sq. m.; pop. in 1870, 6,066, of whom 76 were Chinese. The Rogue River mountains lie on the S. border. The valley of the Umpqua is fertile. Mines of gold, coal, and salt are worked, and quar-

ries of brown sandstone. The Oregon and California railroad is to pass through it. The chief productions in 1870 were 104,246 bushels of wheat, 26,956 of Indian corn, 188,761 of oats, 22,737 of barley, 24,250 of potatoes, 6,573 tons of hay, 75,583 lbs. of butter, and 321,643 of wool. There were 5,265 horses, 4,948 milch cows, 7,964 other cattle, 94,963 sheep, and 16,445 swine. Capital, Roseburg. **IX.** A W. county of Nevada, bounded on the S. W. and W. by California; area, 900 sq. m.; pop. in 1870, 1,215, of whom 23 were Chinese. It embraces the most fertile portion of the Carson river valley and the E. ridge of the Sierra Nevada mountains, and includes Hope valley and portions of Lake valley and Lake Bigler. The mountains are covered with pine forests. Water power is abundant on the streams. There are about 50,000 acres of arable land in the valleys. Mines of gold, silver, and copper exist, but they have not been profitably worked. The chief productions in 1870 were 12,781 bushels of wheat, 37,714 of oats, 40,331 of barley, 20,405 of potatoes, 7,758 tons of hay, and 43,870 lbs. of butter. There were 1,014 horses, and 2,619 cattle. Capital, Genoa. **X.** An E. county of Colorado, bordering on Kansas; area, about 4,500 sq. m.; pop. in 1870, 1,388. It is situated on the plains, and in the S. W. part, which takes in a portion of the "divide," pine timber is abundant. The elevation varies from 3,500 to 8,000 ft. It is watered by Plum, Cherry, Terrapin, Kiowa, and other creeks, tributaries of the Platte. The bottom lands are very fertile, but elsewhere the soil is best adapted to grazing, and only suitable for agriculture when irrigated. Coal and iron ore are found. The Kansas Pacific and the Denver and Rio Grande railroads traverse it. In 1874 Elbert co. was formed from the E. portion, reducing the above area. The chief productions in 1870 were 8,261 bushels of wheat, 5,050 of Indian corn, 22,891 of oats, 4,436 of barley, 7,271 of potatoes, 1,661 tons of hay, and 65,735 lbs. of butter. There were 9,611 cattle. Capital, Frankstown. **XI.** A S. E. county of Dakota; area, about 500 sq. m. It has been recently formed, and is not included in the census of 1870.

**DOUGLAS.** **I.** A seaport town and the capital of the isle of Man, on the E. coast, at the junction of the rivers Dhoo and Glass; pop. in 1871, 13,972. It is a watering place of much resort, and has a harbor capable of admitting vessels of 10 or 12 ft. draught at high water, and a pier 520 ft. long. Steamers from Liverpool, Glasgow, and various ports of Ireland often touch here. Ship building is carried on to some extent, and many of the inhabitants are employed in the coasting trade and the fisheries. The old town is on the S. W. shore of the bay; the new is on terraces rising beyond. The most interesting buildings are Castle Mona (now converted into a hotel) and the "Tower of Refuge," which is on a dangerous rock in the bay. **II.** A village and parish

of Lanarkshire, Scotland, on a river of the same name, 7 m. S. by W. of Lanark; pop. of the parish about 2,500. The parish is owned almost entirely by the heir at law of the Douglas family, who takes from this place his title of baron. The duke of Hamilton is marquis of Douglas. Near the village are the ruins of the ancient church of St. Bride, noted for its numerous family tombs; also Douglas castle, the Castle Dangerous of Scott's novel, built in 1760 on the site of the ancient one, which had been destroyed by fire.

**DOUGLAS**, the name of one of the most ancient and powerful noble families of Scotland, descendants, according to one tradition, of a Fleming, Theobald, to whom Arnold, abbot of Kelso, made a grant of lands on the Douglas or Blackwater, in Lanarkshire, about the middle of the 12th century. According to another story, their progenitor was an unknown chief who, as a reward for success in battle, received lands in the same locality about 770. The best historians do not give credence to either of these legends, but pronounce it impossible to trace the authentic history of the race further back than William de Douglas, about 1175-1213. From him were descended, through Archibald, William and Andrew, successive heads of the house, Sir James Douglas of Loudon, and his cousin, "the good Sir James," who fought with Bruce at Bannockburn, and commanded a portion of the Scottish army. After Bruce's death he was intrusted with the duty of carrying the king's heart, as he had directed, to the Holy Land, and on his journey fell in a combat with the Saracens. From Sir James of Loudon was descended William de Douglas, lord of Liddesdale, called "the flower of chivalry," and from "the good Sir James" Sir William Douglas, knight of Liddesdale, called by Fordun "England's scourge." These two leaders were among the most famous feudal warriors of their time. Sir William, being a natural son, did not inherit the family estates, which passed to Hugh and Archibald, his uncles, through the latter of whom they descended to William, who was made earl of Douglas and lord justiciar of Lothian at the accession of King Robert II., in 1371. By marriage with a daughter of the earl of Mar he became earl of Douglas and Mar. His son James married the daughter of the king, but died without male issue, and the combined titles and estates were again divided, those of Mar going to his sister, and those of Douglas returning into the family of "the good Sir James" in the person of a second natural son, Archibald the Grim, who thus became third earl of Douglas. Meanwhile, George, a descendant of William, the first earl, and Margaret, sister of the third earl of Angus, had obtained in 1389 the earldom of Angus through his mother's resignation of her claim; and another of the family, a descendant of a younger brother of William, lord of Liddesdale, was in 1458 made earl of Morton; so that three

separate earldoms were held by the house of Douglas by the middle of the 15th century. The power of the family was so great in Scotland that a current proverb declared, "No man may touch a Douglas, nor a Douglas's man; for if he do, he is sure to come by the waur."—The two great-grandsons of Archibald the Grim, whose power had been greatly increased through the influence of their father (who had been one of the council of regency after the death of James I., and afterward lieutenant general of the realm), brought the main branch of the family to its highest point of distinction. Taking advantage of the infancy of the heir to the throne, and of the quarrels of the feudal nobles, they made themselves independent of all authority, assumed the state of kings, and for a long time practically maintained a kingdom of their own. Their ruin was effected through a series of political complications, and both were executed for treason in 1440, the earldom passing to a granduncle. By the latter's son William the power of the family was for a time restored, but he was also finally defeated in conflicts with the crown. He was murdered by James II. in 1452, leaving no issue; and with the final defeat of his brother James, after similar attempts to maintain a separate authority, this branch of the house of Douglas was overthrown. The earldom expired by forfeiture in 1455; and Earl James was compelled by James III. to become a monk, and died in the abbey of Lindores in April, 1488.—Meanwhile the Angus branch of the family, in the persons of the descendants of George, had remained loyal during these complicated conflicts, and had consequently increased in power with the waning influence of the older line. In 1455 George, fourth earl of Angus, was rewarded for his devotion to the royal cause by a grant of the old family estate of Douglas Dale, taken from the earl of Douglas. Dying in 1462, he was succeeded by his son Archibald, called "Bell-the-Cat" or "the Great Earl." He derived the former title from an exclamation which he made at a deliberation of the nobles regarding the best means of removing Cochrane, one of the king's favorites, who had become obnoxious. Lord Gray compared the meeting to that of the mice, who decided that the best plan to deliver themselves from the cat's tyranny was to hang a bell about her neck. On the question being raised as to who would dare to perform this feat, Douglas boldly replied, "I will bell the cat." He was warden of the east marches and lord high chancellor, an office which he resigned in 1498. He used his whole influence to dissuade the king (James IV.) from the invasion that ended in the battle of Flodden (1513); and, heart-broken at the results and at the loss of his own sons, two of whom fell in the battle, he retired to the priory at Whitfern, in Galloway, where he died shortly after. One of his surviving sons, Sir Archibald Douglas of Kilsplindie, sustained the family power

in protracted contentions with the Hamiltons, and after holding other offices was made lord treasurer in 1526 by James V.; while the title passed to the great earl's grandson, Archibald, sixth earl of Angus, who also took a prominent part in political affairs, and became lord high chancellor in 1527. He had married in 1514 the queen dowager of Scotland, Margaret, the sister of Henry VIII. of England, and by her became the father of Margaret, afterward wife of the earl of Lennox, mother of Lord Darnley, and grandmother of James VI. In the lawless state of Scotland at this time, Angus held his power by keeping the young king, James V., for a long time a positive prisoner, carrying on meanwhile a constant warfare with other powerful nobles of the kingdom (see JAMES V. of Scotland); but in 1528 James escaped, took affairs into his own hands with the greatest energy, and, turning upon the family that had so long oppressed him, made a vow that during his reign the Douglasses should "have no peace" in the kingdom. Angus was exiled, and sentence of forfeiture passed against him; he remained in England till James's death, after which he was restored to his title and estates. He died in 1556, and was followed by his son and grandson in regular succession; but on the latter's death without male issue the title passed to Sir William Douglas of Glenberrie, great-grandson of Archibald Bell-the-Cat. To him James VI. granted a charter confirming all the ancient rights of the family. He died in 1611, and the title from this time continued in the regular male line of descent, until William, 11th earl, was made marquis of Douglas in 1633. In 1703 the title duke of Douglas was created, but the head of the house, Archibald, dying childless in 1761, this latter became extinct, and the marquissate passed to a relative, the duke of Hamilton. The next succession became a subject of litigation among several branches of the family; but in 1771 the house of lords gave judgment in favor of the son of Lady Jane Douglas, the duke's sister, as the rightful heir; and he was made a peer in 1790, under the title of Baron Douglas of Douglas castle, Lanarkshire, which became extinct at the death of his son James in 1857, when the Douglas estates passed to a niece, the countess of Home.—It has been said that a descendant of a younger brother of William of Liddesdale was made earl of Morton in 1458. This one of the family titles descended in due course for three generations; but the third earl died without male issue in 1553, and the earldom passed to his son-in-law, James Douglas, famous as the regent Morton, and a descendant of Archibald Bell-the-Cat. (See MORTON, EARL OR.) After the execution of the regent in 1581 the Morton title passed to the Angus branch of the family, in the person of Archibald, eighth earl; but when he died without issue in 1588, it devolved upon Sir William Douglas, called "of Lochleven," a descendant of the

knight of Liddesdale's brother. The civil war compelled him to sell a large portion of the Douglas lands. What remained of his part of the family property descended with the title in due course to the present earl of Morton, who bears with it the titles attaching to two portions of the Douglas estates, viz., that of Baron Douglas of Lochleven (conferred on George, 18th earl of Morton, in 1791), and Lord Aberdour (created at the same time with the Morton earldom).—Other titles have been conferred at various periods on members of the main family, not mentioned in the history just given of the direct lines. Thus, in 1646, the title of earl of Selkirk was conferred on the third son of the first marquis of Douglas, and in 1651 the oldest son of that marquis was made earl of Ormond, and in 1661 earl of Forfar. In 1675 a fourth son of the same family was made earl of Dumbarton. In 1641 the title of Lord Mordington was conferred on the second son of the 10th earl of Angus. All these titles are now extinct or dormant excepting that of earl of Selkirk. The descendants of Sir William Douglas of Drumlanrig, an illegitimate son of the second earl of Douglas and Mar, form another important branch of the Douglas family. They were created successively viscounts of Drumlanrig (1628), earls of Queensberry (1633), marquises of Queensberry (1682), dukes of Queensberry (1684), earls of March (1697), and earls of Solway (1706). The title of duke of Queensberry passed, however, in 1810, to the duke of Buccleuch; the title of marquis of Queensberry is still borne by the lineal descendants of the family. In the Angus branch of the Douglas family certain privileges were vested, among them the right, in ancient times, to cast the first vote in parliament, to lead the vanguard in battle, and to bear the crown in public solemnities. The right to bear the Scottish crown in its coat of arms was retained by the family to the present century. The motto *Jamais arriere* probably commemorates these hereditary honors of the earls of Angus; while "the good Sir James Douglas" added to the armorial bearings the conspicuous device of the bloody heart, commemorative of the bequest of Robert Bruce. The Douglasses also bear upon their arms three stars (mullets), which is also a device of the Murrays, and lends a degree of probability to the theory of some genealogists, that the families descend from a common stock.—For the history of the Douglas family see especially "A History of the Houses of Douglas and Angus," by David Hume of Godscroft, first printed in folio, 1644, and reprinted in 1748. This work, though valuable to the antiquary, is not always historically accurate. See also vol. i. of Chalmers's "Caledonia" (London, 1807), and Robertson's *Origines Parochiales Scotiae* (Edinburgh, 1851).

**DOUGLAS, David**, a British botanist, born in Scone, Scotland, in 1798, killed in the Hawaiian islands, July 12, 1834. He was employed

as a laborer in the Glasgow botanic garden, where his intelligence attracted the notice of Dr. (afterward Sir William) Hooker, who procured for him an appointment as botanical collector to the horticultural society of London. In this capacity he travelled extensively in America; in 1824 explored the Columbia river and California, and in 1827 traversed the continent from Fort Vancouver to Hudson bay, where he met Sir John Franklin, and returned with him to England. He made a second visit to the Columbia in 1829, and went to the Hawaiian islands. There he fell into a pit made for wild cattle, and was killed and mutilated by an animal previously entrapped. Through his agency 217 new species of plants were introduced into England. He collected 800 specimens of the California flora.

**DOUGLAS, Gawin, or Gavin,** a Scottish poet, bishop of Dunkeld, third son of Archibald, fifth earl of Angus (called "Bell-the-Cat"), born in Brechin about 1474, died in London in 1521 or 1522. He was educated for the church, partly in Scotland and partly at Paris, and when 22 years of age was appointed rector of Hawick. While in this office he made a translation of Ovid's "Remedy of Love," which has been lost. In 1501 he addressed to King James IV. the "Palace of Honor," an allegory whose structure so much resembles the "Pilgrim's Progress," that Bunyan has been thought to have borrowed his idea from it. About 1509 he was appointed provost of St. Giles's, Edinburgh. His translation of the Æneid into Scottish verse, made in 1512-'13, was first printed at London in 1553, with the following title: "The xiii. bukes of Eneados of the famos poet Virgill, translated out of Latyne verses into Scottish metir, bi the Reuerend Father in God, Mayster Gawin Douglas, Bishop of Dunkel, & vnkil to the Erle of Angus: euery buke hauing hys perticular prologe." It is praised for its spirit and fidelity. The 13th book was the production of Mapheus Vegius. In September, 1513, Douglas accompanied the king to Flodden field, where his two elder brothers, the master of Angus and Sir William Douglas, with 200 gentlemen of their name, were slain. Soon afterward the earl his father died of grief. The chief of the house of Douglas was now the young earl of Angus, nephew of Gawin. This youth married the queen regent, and was the means of Gawin's obtaining the abbacy of Aberbrothwick, and a nomination to the archbishopric of St. Andrews, which would have made him head of the church in Scotland. The pope would not assent to this appointment, and as the partisans of the various candidates appealed to arms, it ended in Gawin's abbacy being taken from him. The queen made him bishop of Dunkeld in 1515, but on attempting to establish himself in his see he found it in armed possession of the earl of Athol's brother, Andrew Stewart. Douglas's friends rallied in force and took the cathedral, after which the contention went on for years

between the rival families of Angus and Hamilton, and in April, 1520, they met in Edinburgh to fight it out. Bishop Gawin, foreseeing bloodshed, endeavored to prevent the fray. But his intercessions were of no avail; the forces of the rival lords met, and Hamilton was defeated. The next year the regent Albany called the Angus party to account, and the earl, with Gawin and the chief men of his name, were forced to fly to England, where Henry VIII. received them well and allowed Gawin a pension. An allegorical poem of his, entitled "King Hart," was left in manuscript, and published by Pinkerton in his "Ancient Scottish Poems," 1788.

**DOUGLAS, Sir Howard,** an English general, born in Gosport, Hampshire, July 1, 1776, died at Tunbridge Wells in November, 1861. He entered the army at an early age, served in the Walcheren expedition, and in the Spanish and Portuguese campaigns of 1808-'12. He succeeded his brother as third baronet, May 24, 1809, and was governor of New Brunswick from 1823 to 1829, lord high commissioner of the Ionian Islands from 1835 to 1840, and member of parliament for Liverpool from 1842 to 1847. In 1851 he was raised to the rank of general. He was the author of several valuable works on military science, among which are an essay "On the Construction of Military Bridges," &c. (1816), "A Treatise on Naval Gunnery" (1819), and one on "Naval Evolutions" (1832). In a fourth edition of his "Naval Gunnery" (1855) he reviewed very severely the operations in the Crimea.

**DOUGLAS, John,** an English prelate, born in Pittenweem, Fifeshire, Scotland, in 1721, died in Salisbury, May 18, 1807. He was chaplain to a regiment of foot guards serving in Flanders, was present at the battle of Fontenoy (1745), and was employed by Gen. Campbell in carrying orders. Having held various benefices, he was chosen president of Sion college in 1781, made bishop of Carlisle in 1787, and dean of Windsor in 1788; and in 1791 he was translated to the see of Salisbury. He wrote "A Vindication of Milton from the charge of Plagiarism," and many religious and political pamphlets; and he superintended in 1762 the publication of the second Lord Clarendon's "Diary and Letters;" in 1777, Lord Hardwick's "Miscellaneous Papers," and Capt. Cook's second voyage; and in 1781, Capt. Cook's last voyage. His religious writings include anniversary sermons, and "The Criterion, or Miracles Examined," in reply to Hume.

**DOUGLAS, Stephen Arnold,** an American statesman, born at Brandon, Vt., April 23, 1813, died in Chicago, June 3, 1861. His father, who was a physician, died when Stephen was about two months old. The widow with her children retired to a farm, on which her son resided till he was 15 years old, when he determined to earn his own living, and engaged himself as an apprentice in cabinet making. After a year and a half his health became impaired

by hard work, and he abandoned the occupation. He then attended Brandon academy a year. His mother about this time married Mr. Granger of Ontario co., N. Y., and young Douglas removed with her to Canandaigua and entered the academy at that place. He studied law at the same time that he pursued his academical course, and in the spring of 1833 went to the west. At Jacksonville, Ill., he found his funds reduced to 37½ cents, and accordingly walked to Winchester, 16 miles, where he hoped to get employment as a teacher. He found there a large crowd assembled to attend an auction. The auctioneer was without a clerk, and perceiving that Douglas, who stood among the spectators, looked like a man who could keep accounts, requested him to serve in that capacity. He acted as clerk during the three days of the sale, and received \$6 for his services. With this capital he opened a school, and obtained 40 pupils, whom he taught for three months, devoting his evenings to the study of law, and on Saturday afternoons practising in petty cases. In March, 1834, he opened an office and began practice in the higher courts, having been admitted to the bar. He was remarkably successful, and within a year from his admission, while not yet 22 years of age, was elected by the legislature attorney general of the state. This office he resigned in December, 1835, in consequence of having been elected to the legislature. He took his seat in the house of representatives, the youngest member of that body. In 1837 he was appointed by President Van Buren register of the land office at Springfield, Ill., a post which he resigned in 1839. In November, 1837, he received the democratic nomination for congress, although he was under the requisite age of 25 years, which however he attained before the day of election in the following August. His congressional district was then the most populous in the United States, and the canvass was conducted with extraordinary zeal and energy. More than 36,000 votes were cast, and the whig candidate was declared elected by a majority of only five votes. After this defeat Douglas devoted himself exclusively to his profession till 1840, when he entered into the famous presidential campaign of that year with much ardor. In December, 1840, he was appointed secretary of state of Illinois. In the following February he was elected by the legislature a judge of the supreme court, which office he resigned in 1843 to accept the democratic nomination for congress. He was chosen by upward of 400 majority, and was reelected in 1844 and in 1846. But before taking his seat under the last election he was chosen to the senate of the United States for six years from March 4, 1847. In the house of representatives he was prominent among those who, in the Oregon controversy with Great Britain, maintained that our title to the whole of Oregon up to lat. 54° 40' was "clear and unquestionable." He declared that "he never would,

now or hereafter, yield up one inch of Oregon, either to Great Britain or any other government." He advocated the policy of giving notice to terminate the joint occupation; of establishing a territorial government over Oregon, protected by a sufficient military force; and of putting the country at once in a state of preparation, so that if war should result from the assertion of our just rights, we might drive "Great Britain and the last vestiges of royal authority from the continent of North America, and make the United States an ocean-bound republic." He was among the earliest advocates of the annexation of Texas, and after the treaty for that object had failed in the senate, he was one of those who introduced propositions, in the form of joint resolutions, as a substitute for it. As chairman of the committee on territories in 1846 he reported the joint resolution declaring Texas to be one of the United States of America, and he vigorously sustained the administration of President Polk in the prosecution of the war with Mexico, which was the ultimate consequence of that act. As chairman of the territorial committee, first in the house of representatives and afterward in the senate, he reported and carried through the bills to organize the territories of Minnesota, Oregon, New Mexico, Utah, Washington, Kansas, and Nebraska, and also the bills for the admission into the Union of the states of Iowa, Wisconsin, California, Minnesota, and Oregon. On the question of slavery in the territories he early took the position that congress should not interfere on the one side or the other, but that the people of each territory and state should be allowed to regulate their domestic institutions to suit themselves. In accordance with this principle he opposed the "Wilmot proviso" when first passed in the house of representatives in 1847, and afterward in the senate when offered as an amendment to the bill for the organization of the territory of Oregon. In August, 1848, however, he offered an amendment to the Oregon bill, extending the Missouri compromise line to the Pacific ocean, thus prohibiting slavery in all the territory north of the parallel of 36° 30', and by implication recognizing its existence south of that line. This amendment was adopted in the senate by a decided majority, receiving the support of every southern together with several northern senators, but was defeated in the house of representatives by nearly a sectional vote. The refusal of the senate to adopt the policy of congressional prohibition of slavery in all the territories, and the rejection in the house of representatives of the proposition to extend the Missouri compromise to the Pacific ocean, gave rise to the sectional agitation of 1849-'50, which was temporarily quieted by the legislation known as the compromise measures of 1850. Mr. Douglas supported these measures; and on his return to his home in Chicago, finding them assailed with great violence, he de-



fended the whole series in a speech (Oct. 24, 1850) in which he defined the principles on which the compromise acts of 1850 were founded, and upon which he subsequently defended the Kansas-Nebraska bill in these words: "These measures are predicated on the great fundamental principle that every people ought to possess the right of framing and regulating their own internal concerns and domestic institutions in their own way. . . . These things are all confided by the constitution to each state to decide for itself, and I know of no reason why the same principle should not be extended to the territories." Mr. Douglas was an unsuccessful candidate before the democratic national convention at Baltimore in 1852 for the nomination for the presidency. On the 30th ballot he received 92 votes, the highest number given to any candidate on that ballot, out of a total of 288 votes. At the congressional session of 1853-'4 he reported the celebrated bill to organize the territories of Kansas and Nebraska, which effectually revolutionized political parties in the United States, and formed the issues upon which the democratic and republican parties became arrayed against each other. The passage of this bill caused great excitement in the free states of the Union, and Mr. Douglas as its author was widely and vehemently denounced, and in many places was hanged and burned in effigy. The whole controversy turned on the provision repealing the Missouri compromise, which he maintained was inconsistent with the principle of non-intervention by congress with slavery in states and territories. After repealing the Missouri restriction, the bill declared it to be the "true intent and meaning of the act, not to legislate slavery into any state or territory, nor to exclude it therefrom, but to leave the people thereof perfectly free to form and regulate their domestic institutions in their own way, subject only to the constitution of the United States." In 1856 he was again a candidate for the presidential nomination before the democratic convention at Cincinnati. The highest vote he received was on the 16th ballot, which stood for Buchanan 168, for Douglas 121, for Cass 6. In the congressional session of 1857-'8 he denounced and opposed the Lecompton constitution, on the ground that it was not the act of the people of Kansas, and did not embody their will. Before the adjournment of that session he returned home to vindicate his action before the people of Illinois in one of the most exciting and well contested political canvasses ever known in the United States, his antagonist on the stump being Abraham Lincoln, who was then the republican candidate for senator. The popular vote at the subsequent election was adverse to Mr. Douglas, but he succeeded in carrying the election of a sufficient number of state senators and representatives to secure his return to the United States senate by 54 votes for him to 46 for Lincoln.—Mr. Douglas was remarkably suc-

cessful in promoting the local interests of his own state during his congressional career. To him, more than to any other individual, is Illinois indebted for the magnificent grant of lands which secured the construction of the Illinois Central railroad, and contributed so much to restore the credit and develop the resources of the state. He was a warm supporter and advocate of a railroad from the Mississippi river to the Pacific ocean. In foreign policy he opposed the treaty with England limiting the Oregon territory to the 49th parallel, contending that England had no rights on that coast, and that the United States should never recognize her claim. He also opposed the ratification of the Clayton-Bulwer treaty, and endeavored to procure its rejection, on the ground, among others, that it pledged the faith of the United States for all time to come never to annex, colonize, or exercise dominion over any portion of Central America. He maintained that the isthmus routes must be kept open as highways to the American possessions on the Pacific, that the time would come when the United States would be compelled to occupy Central America, and that he would never pledge the faith of the republic not to do in the future in respect to this continent what its interests and safety might require. He also declared himself in favor of the acquisition of Cuba whenever the island could be obtained consistently with the laws of nations and the honor of the United States.—In 1860 he was the candidate of the northern section of the democratic party for the presidency, Mr. Breckinridge being supported by the southern section. Mr. Douglas received a popular vote of upward of 1,300,000, though he got only 12 electoral votes, while Mr. Lincoln, who was elected, got 180. In the stormy discussions in the senate at the beginning of the civil war Mr. Douglas took a prominent part in support of the government and the Union. In his speeches to the people after the adjournment of congress, he denounced secession as crime and madness, and declared that if the new system of resistance by the sword and bayonet to the result of the ballot box shall prevail in this country, "the history of the United States is already written in the history of Mexico." In a letter dictated for publication during his last illness, dated May 10, 1861, he said but one course was left to patriotic men, and that was to sustain the Union, the constitution, the government, and the flag, against all assailants. On his death-bed his last coherent words expressed an ardent wish for the honor and prosperity of his country and the defeat and dispersion of her enemies.—Mr. Douglas was a strongly built man, somewhat below the middle height, and hence was popularly known as "the little giant." He was a powerful speaker, and few Americans have surpassed him in personal influence over the mass of the people. He was married, April 7, 1847, to Martha, daughter of

Col. Robert Martin of Rockingham co., N. C., by whom he had three children, two of whom are living, and the eldest of whom, Robert Martin Douglas, is now (1873) private secretary to President Grant. She died Jan. 19, 1853. He was again married, Nov. 20, 1856, to Adèle, daughter of James Madison Cutts of Washington, D. C., who survived him, and is now the wife of Gen. Robert Williams, U. S. A. Senator Douglas's life, by James W. Sheahan, was published in 1860.

**DOUGLASS, David Bates**, an American engineer, born in Pompton, N. J., March 21, 1790, died in Geneva, N. Y., Oct. 19, 1849. He graduated at Yale college in 1813, entered the army as second lieutenant of engineers, and for his share in the defence of Fort Erie was made first lieutenant, with the brevet rank of captain. In 1815 he was appointed assistant professor of natural and experimental philosophy at West Point, in 1819 was astronomical surveyor of the boundary commission from Niagara to Detroit, and in the summer of 1820 accompanied Governor Cass in a similar capacity to the northwest. In August he became professor of mathematics at West Point, with the rank of major, and in 1823 professor of civil and military engineering. In this science he soon acquired a wide reputation. He was employed by the state of Pennsylvania during the summer recesses from 1826 to 1830 as a consulting engineer, and was charged with several of the more difficult parts in its system of public works. In 1831 he resigned his professorship and became chief engineer of the Morris canal. In 1832 he was appointed professor of civil architecture in the new university of the city of New York, and prepared the designs for its building. In June, 1833, he commenced his surveys for supplying New York with water, and in November submitted his first report, showing how to obtain a supply from the Croton river. In 1835, his plan having been accepted, he was elected chief engineer, and had accomplished the preliminary work when he was superseded. In 1839 he planned and laid out Greenwood cemetery. He was president of Kenyon college, Ohio, from 1841 to 1844, when he returned to the vicinity of New York. In 1845-'6 he laid out the cemetery at Albany, and in 1847 was employed in developing the landscape features of Staten Island. In 1848 he laid out the Protestant cemetery at Quebec, and was elected professor of mathematics and natural philosophy in Hobart college, Geneva, N. Y.

**DOUGLASS, Frederick**, an American orator and journalist, born at Tuckahoe, near Easton, Talbot co., Md., about 1817. His mother was a negro slave and his father a white man. He was reared as a slave on the plantation of Col. Edward Lloyd, until at the age of 10 he was sent to Baltimore to live with a relative of his master. He secretly taught himself to read and write, was employed in a ship yard, and, in accordance with a resolution long entertained,

fled from Baltimore and from slavery Sept. 3, 1838. He made his way to New York and thence to New Bedford, where he married and lived for two or three years, supporting himself by day labor on the wharves and in various workshops. In the summer of 1841 he attended an anti-slavery convention at Nantucket, and made a speech which was so well received that he was offered the agency of the Massachusetts anti-slavery society. In this capacity he travelled and lectured through Massachusetts and other New England states for four years. In 1845 he published an autobiography, and soon after its appearance he went to Europe and lectured on slavery to enthusiastic audiences in nearly all the large towns of England, Ireland, Scotland, and Wales. In 1846 his friends in England contributed £150 to have him regularly manumitted in due form of law. He remained two years in Great Britain, and in 1847 he began at Rochester, N. Y., the publication of "The North Star," whose title was changed to "Frederick Douglass's Paper," a weekly journal, which he continued for some years. In 1855 he rewrote and enlarged his autobiography, under the title of "My Bondage and my Freedom." His supposed implication in the John Brown raid in 1859 led Governor Wise of Virginia to make a requisition for his arrest upon the governor of Michigan, where he then was. In consequence of this Mr. Douglass went to England, and remained six or eight months. He then returned to Rochester, and continued the publication of his paper. When the civil war broke out in 1861 he urged upon President Lincoln the employment of colored troops and the proclamation of emancipation. In 1863, when permission was given to employ such troops, he assisted in procuring men to fill up regiments of them, especially the 54th and 55th Massachusetts. After the abolition of slavery he discontinued his paper and applied himself to the preparation and delivery of lectures before lyceums. In September, 1870, he became editor of the "New National Era" in Washington, which is continued under the care of his sons Lewis and Frederick. In 1871 he was appointed secretary to the commission to Santo Domingo; and on his return President Grant appointed him one of the territorial council of the District of Columbia. In 1872 he was elected presidential elector at large for the state of New York, and was appointed to carry the electoral vote of the state to Washington.

**DOUR**, a town of Belgium, in the province of Hainault, 9 m. S. W. of Mons; pop. in 1866, 8,501. It has large iron works and several bleaching grounds, and in the vicinity are coal and iron mines. Weaving and leather dressing are carried on to some extent.

**DOURO**, or **Duero**, one of the largest rivers of the Iberian peninsula, rises near Monte Ur-bion, on the northern frontier of the province of Soria in Spain, about 20 m. N. W. of the city of Soria. After following a southeasterly course for about 50 m. it makes an abrupt bend

and flows westward; this continues to be its general direction, in which it passes Aranda, Toro, Zamora, and Miranda, until it empties into the Atlantic at Oporto. Its current is rapid, and its course for the most part through narrow valleys. For about 50 miles it forms the boundary between Spain and Portugal. It is navigable for small vessels as far as the Spanish frontier, and receives the waters of the Pisuerga, Sequillo, Esla, Sabor, Tua, and Tamego from the north, and the Adaja, Tormes, Agueda, Coa, and Tavora from the south, besides many smaller streams. Navigation is often interrupted by freshets, and the river is but little used for commerce. On its banks are the vineyards which produce the celebrated wines of Oporto. Its length is estimated at 450 to 500 m.

**DOUROUCOULI** (*nyctipithecus trivirgatus*), a small monkey found in Guiana and Brazil. In this genus the middle incisors are broad, and the canines moderate; eyes large; external ears not prominent beyond the fur; hind feet longest; tail longer than the body, not

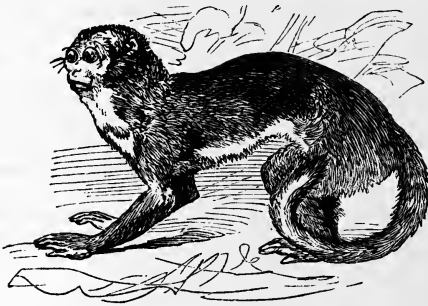

Douroucoulli.

prehensile. As its generic name implies, it is nocturnal, sleeping by day, but very active and fierce at night in search of insects and small birds. It is about 9 in. long, with a tail of 14 in.; the fur is soft, grayish white, with a brown line on the back, three dark stripes on the head, and yellowish brown below. It looks more like a cat than a monkey, and the mouth is surrounded by bristly white hairs. When seated it assumes the position of a dog, and when sleeping the head is bent forward between the feet; it is difficult to tame, and its voice is loud and disagreeable. Humboldt called it *aotes*, earless, though the ears are not particularly small. It lives in pairs, and resembles in appearance and habits the lemurs of the old world. F. Cuvier gave it the name of *nocthora*, from its nocturnal habits.

**DOUVILLE, Jean Baptiste**, a French traveller and naturalist, born at Hambie, Feb. 15, 1794, disappeared in the wilds of South America about 1833. He travelled in Europe, South America, and Asia, landing at Genoa on his return in 1824. In 1826 he went to Paris, where he was made member of the geographical society, and then sailed for Buenos Ayres. The river La

Plata was at that time under blockade by the Brazilians, and the French vessel was captured; but Douville was befriended by the Brazilian admiral, and sent to Buenos Ayres, where, finding his resources nearly exhausted, he attempted to replenish them by mercantile operations. Accused of some fraudulent transaction of which he was acquitted, he left Buenos Ayres in disgust, and went to Rio de Janeiro. On Oct. 15, 1827, he embarked for Congo, whence he returned to France in 1831. The stories of his discoveries in several kingdoms hitherto almost unknown to Europeans, and of his exploration of the Congo or Zaire and other rivers, aroused great enthusiasm among the Parisians. He received a medal from the geographical society; his researches were published under the title of *Voyage au Congo et dans l'Afrique équinoxiale* (4 vols., with a map, Paris, 1832), and his book and chart were used as the basis of subsequent maps of Africa. But the "Foreign Quarterly Review" assailed him as an impostor, and a few weeks later his deceptions were more fully exposed in the *Revue des Deux Mondes*. To cover his shame by real discoveries, he sailed for Brazil in 1833, and penetrated to the interior of South America by the Amazon, where, according to an uncertain report, he was killed.

**DOUW**, or **Dow, Gerard**, a Dutch painter, born in Leyden in 1613, died there in 1680. After receiving instruction in his early boyhood in drawing and in painting on glass, he became in 1628 a pupil of Rembrandt, under whom he studied for three years. He began with portrait painting, but was so extremely slow that no one would sit to him. He then painted domestic scenes. He was so exact in imitation, that a glass is needed to appreciate the skill and delicate finish of his work. His drawing was neither bold nor correct, but his figures are not wanting in life and expression, and his coloring is strong, fresh, and harmonious. He had none of the poetical taste of his master, for his pictures generally consist of two or three figures engaged in the most trivial and often disagreeable occupations, as many of their titles indicate. Among the most celebrated are the "Dropsical Woman," the "Village Grocer's Wife," the "Dentist," and the "Violin Player." His works are to be found in all the public galleries of Europe, but private fortunes could hardly command them, for it was Douw's rule to be paid for his pictures according to the time they cost him.

**DOVE.** See PIGEON.

**DOVE**, a river of England, rising on Axe Edge hill, near Buxton, in the N. W. part of Derbyshire, flowing S. and S. E. for about 40 m., and emptying into the Trent a short distance below Burton. For almost its entire course it forms the boundary between Derbyshire and Staffordshire. It is remarkable for the clearness of its water and the picturesqueness of its banks, especially in that part of its valley known as Dove Dale, where, near Ash-

bourne, it flows through a gorge of great beauty. The Dove frequently overflows, but generally with beneficial results to the land along its course. It is celebrated as a fishing stream, especially by Izaak Walton.

**DOVE. I. Heinrich Wilhelm**, a German physicist, born in Liegnitz, Prussian Silesia, Oct. 6, 1803. He was educated at Liegnitz, Breslau, and Berlin, in 1826 became a teacher and subsequently a professor extraordinary in the university of Königsberg, and in 1829 was invited to a similar chair in Berlin. In 1837 he was admitted to the academy of sciences, and in 1845 he became full professor of physics. He has investigated the laws which regulate atmospheric phenomena, and evolved them with clearness and precision. His reports and isothermal maps afforded the first representation of the isothermal lines of the whole globe for every month of the year, besides much kindred information, whose importance can scarcely be overestimated. He was the first to announce the presence of a secondary electric current in a metallic wire, at the moment that the circuit of the principal current is completed. Of his works, many of which have appeared in the transactions of the Berlin academy of sciences, and in Poggenдорff's *Annalen*, the principal are: *Ueber Mass und Messen; Meteorologische Untersuchungen; Ueber die nicht-periodischen Aenderungen der Temperaturvertheilung auf der Oberfläche der Erde; Untersuchungen im Gebiete der Inductionselektricität; Temperaturtafeln; Monatsisothermen; und Das Gesetz der Stürme*, which has been translated into French and English. In a more popular style he has written several treatises on meteorological and electrical phenomena, which have found many readers. In the capacity of director of the Prussian observatories he publishes each year the results of their labors. Among his most recent writings are *Klimatologische Beiträge* (Berlin, 1857 *et seq.*), *Monats- und Jahresisothermen in der Polarprojektion* (1864), *Klimatologie von Norddeutschland* (1868-'71), and papers on electricity, the movement of water, &c. **II. Richard Wilhelm**, a German jurist, son of the preceding, born in Berlin, Feb. 27, 1833. On graduating at the university of Berlin in 1854 he delivered a thesis on ecclesiastical jurisdiction in Germany and France which attracted much attention. He served one year in the Prussian army, and in 1859 became a *Privatdozent* at Berlin, his lectures meeting with remarkable success. In 1860 he founded the *Zeitschrift für Kirchenrecht*, which he at first edited alone. In 1862 he was made extraordinary professor of ecclesiastical and German law at Tübingen, and in 1863 full professor. In 1865 he accepted a similar position at Kiel, and in 1868 at Göttingen. In 1869, when he was appointed by the king a member of the national synod, he earnestly opposed the efforts of the clerical delegates of the extreme Lutheran party to introduce, even in matters connected with the

church, obstacles to the union of Germany; and the same desire for unification inspired his action in more purely political contests, in which he engaged with much ability.—His services in this cause led to his election in 1871 to the first German Reichstag. He has published several essays in the *Zeitschrift für Kirchenrecht*, and he had charge of the revision of Richter's text book of ecclesiastical law.—His younger brother ALFRED edited the *Grenzboten* in 1869-'70, and since January, 1871, has been the editor of a similar politico-literary journal entitled *Im neuen Reich* (Leipsic).

**DOVER** (Fr. *Douvres*; anc. *Dubris*), a seaport (one of the cinque ports) of England, on the S. E. coast of the county of Kent, on the straits of Dover, in lat. 51° 7' N., lon. 1° 19' E., 62 m. S. E. of London (with which it is connected by the London, Chatham, and Dover, and the Southeastern railways), and 21 m. N. W. from the coast of France, to which it is the nearest English seaport; pop. in 1871, 28,270. The town is on a small bay, in a low interval formed between the lofty cliffs along the shore by the valley of a little stream call the Dour. The older portion is irregularly and rather poorly built, principally on one street, which runs parallel with the valley. The newer part faces the water; this includes many well built houses and several large hotels. There are about 20 places of worship, a theatre, museum, reading rooms, &c. The harbor consists of three basins, and though formerly possessing few advantages, it has during the past 20 years been so improved by the government, at immense cost, that it now forms a good anchorage for vessels of ordinary size. The entrance is sheltered by the admiralty pier, 1,700 ft. long, built of stone. The trade of the town is inconsiderable; ship building and rope manufacture are carried on, and there are some smaller industries; but its prosperity chiefly arises from the constant passage of travellers and freight to and from the continent, and the visits of those who come in summer for the bathing and sea air. Lines of steamers connect Dover with Calais, Ostend, and Boulogne. The submarine telegraph between England and the continent crosses the channel from Dover to Calais; it was completed in October, 1851. The castle of Dover, one of the most remarkable edifices in England, stands on the summit of a chalk cliff about 1½ m. N. E. of the town. Its walls enclose 35 acres. It is supposed to have been founded by the Romans, but some portions are Norman and Saxon, while others belong to still later epochs. It contains a spacious keep, used as a magazine, and barracks for 2,000 men. Within the precincts of the castle stands an octagonal watch tower, interesting not only as the earliest specimen of Roman architecture, but also as one of the most ancient pieces of regular masonwork in Great Britain.—In the neighborhood of Dover Cæsar made his first attempt to land on the British coast, but he was induced to change his point



Dover, England.

of debarkation by the abruptness of the shore and other difficulties. Under the Saxon kings it became a position of great importance in the defence of Kent. In the reign of Edward the Confessor it was made one of the cinque ports, and was looked upon as the key of the kingdom. After the establishment of the Norman rule it suffered from the vengeance of William

is connected with Boston and Portland by the Boston and Maine railroad, and with Lake Winnepiseogee by the Dover and Winnepiseogee railroad. A railroad to Portsmouth is in process of construction. The city is regularly laid out, and contains many elegant residences. The city hall is a commodious and substantial brick edifice. The high school building is one of the finest in the state. The Cochecho furnishes great motive power, the principal fall being 32½ ft. The supply of water is maintained through the dry season by draining Bow pond in the town of Strafford, about 15 m. W. N. W., which has been converted into an immense reservoir. Black river, in the S. part of the city, also furnishes water power. It has four large mills for the manufacture of print cloths, and extensive print works, which produce 31,000,000 yards annually, valued at \$3,410,000. The value of cotton goods manufactured annually is \$1,125,000; of woollen goods, \$380,000; of boots and shoes (1,200,000 pairs), \$1,800,000; of carriages, \$75,000; of lumber, \$28,000. There are also tanneries, brass and iron foundries, machine shops, manufactories of hats and caps, of sandpaper, of glue, and of oil cloth. In 1870 the capital invested in manufactures was \$2,031,000; males employed, 1,384; females, 972; value of products, \$7,130,000. There are three national banks, with an aggregate capital of \$320,000. The value of property is about \$6,000,000. The city is divided into four wards. There is a high school, and 3 grammar and 31 primary schools, employing 36 teachers, and having an average attendance of 1,270 pupils. The city library contains 4,500 volumes. There are three weekly newspapers, and eight churches.—Dover was settled in 1623, and is the oldest town in the state. It was attacked by Indians

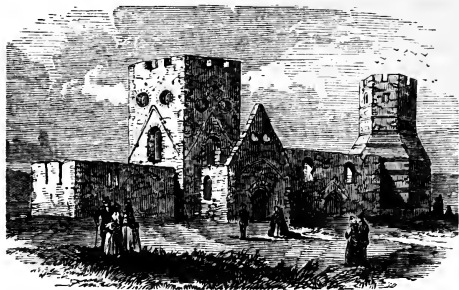

Ancient Church and Pharos.

the Conqueror, to whom it had made strong opposition. In 1213 King John performed at Dover the ceremony of submission to the pope, giving up his authority to the papal nuncio. In 1295 the French made a descent upon the place, and committed great depredations.

**DOVER**, a city and the capital of Strafford co., New Hampshire, situated on both sides of the Cochecho river, about 2 m. from its confluence with the Piscataqua, and 12 m. from the ocean, 35 m. E. of Concord, and about 60 m. N. of Boston; pop. in 1870, 9,294. Small craft ascend at high tide to the falls of the Cochecho within the city limits, and improvements in the channel are in progress which will enable large vessels to reach the city. It

on the night of June 27, 1689, when 23 of the inhabitants were killed and 29 carried into captivity. A city charter was granted in 1855.

**DOVER**, a town of Morris co., New Jersey, on the Rockaway river and Morris canal, about 7 m. N. N. W. of Morristown and 32 m. W. by N. of New York; pop. about 2,000. It is on the Delaware, Lackawanna, and Western railroad, and is the terminus of the Chester branch. It is situated in a region abounding in fine natural scenery, but derives its chief importance from the iron mines of the vicinity, and from its iron manufactures. The town contains an extensive rolling mill, a planing mill, a sash, blind, and door factory, a steam saw mill, a carriage factory, a brass and iron foundry, a printing establishment, and machine and car shops. There are six churches, four hotels, a national and a state bank, two savings banks, and a newspaper.

**DOVER**, a town in the hundred of the same name, capital of Delaware, and seat of justice of Kent county, situated on St. Jones river and the Delaware railroad, 48 m. S. of Wilmington; pop. of the hundred in 1870, 6,394, of whom 1,839 were colored; of the town, 1,906, of whom 501 were colored. It is regularly built, mostly of brick, on high ground. The streets are wide, straight, well shaded, and cross each other at right angles. The principal public buildings face an open square, planted with elms, the E. side of which is occupied by a handsome state house. A new county court house and a new post office are in process of construction. The town contains a flour mill, two saw mills, a national and a state bank, an insurance company, two hotels, an academy, seven public and three private schools, a weekly newspaper, and six churches. Dover is the centre of the fruit-canning trade.

**DOVER**, a township of Tuscarawas co., Ohio, on the right bank of Tuscarawas river, near the mouth of Sugar creek, about 70 m. S. by E. of Cleveland; pop. in 1870, 3,515. The village of Canal Dover in this township (pop. 1,593) is regularly laid out on the W. side of the Ohio canal, across which and the river there is a bridge 346 ft. long. It is the shipping point for large quantities of wheat and flour. It contains mills, furnaces, and tanneries, and a woollen factory.

**DOVER**, Strait of (Fr. *Pas de Calais*; anc. *Fretum Gallicum*), a strait connecting the English channel with the North sea, and separating England from France. It extends from Dungeness and Cape Gris Nez N. E. to the South Foreland and Calais; length, 24 m.; breadth at Dover, where it is narrowest, 21 m.

**DOVER'S POWDER**, a preparation of ipecacuanha and opium, each a drachm, and of sulphate of potassa an ounce, rubbed together into a very fine powder. Though called by the name of Dr. Dover, it differs from that originally recommended by him, which contained also nitrate of potash and licorice. It is admirably adapted for promoting perspira-

tion, and possesses at the same time the properties of an anodyne. It is given after depletion, in cases requiring profuse diaphoresis, and is particularly used in dysentery, diarrhœa, and affections of the liver and of the bowels.

**DOVREFIELD** (Dan. *Dovre Fjeld*), a mountain range of Norway, extending from the termination of the Langfield range, near lat. 62° N., to the beginning of the Kiölen range, about lat. 63°. Sneehætten, its principal peak, lat. 62° 20' N., lon. 9° 20' E., is one of the highest mountains of the Scandinavian peninsula (7,562 ft.), and its summit is always covered with snow. Four passes cross the Dovrefield range, the most frequented being on the E. side of the Sneehætten, on the road between Christiania and Drontheim. These mountains are granitic in character. In some of the highest gneiss predominates; in others mica schist. Red porphyry is found, which at a certain depth has the characteristics of syenite. Among the metals produced are iron, copper, and silver.

**DOW**, **Lorenzo**, an eccentric American preacher, born in Coventry, Conn., Oct. 16, 1777, died in Washington, D. C., Feb. 2, 1834. At an early age he was greatly distressed by religious speculations, until his acceptance of Methodist doctrines and his determination to become a preacher of that denomination, though his education was very limited. In 1796 he made an unsuccessful application for admission into the Connecticut conference; but two years later he was received, and in 1799 was appointed to the Cambridge circuit, New York. During the year he was transferred to Pittsfield, Mass., and afterward to Essex, Vt., but remained there only a brief time, as he believed he had a divine call to preach to the Catholics of Ireland. He made two visits to Ireland and England, in 1799 and 1805, and by his eccentric manners and attractive eloquence drew after him immense crowds, who sometimes indulged in a spirit of bitter persecution. He introduced camp meetings into England, and the controversy about them resulted in the organization of the Primitive Methodists. In 1802 he was preaching in the Albany district, N. Y., "against atheism, deism, Calvinism, and Universalism." He passed the years 1803 and 1804 in Alabama, delivering the first Protestant sermon within the bounds of that state. In 1807 he extended his labors into Louisiana, following the settlers to the extreme borders of civilization, and preaching to half-civilized throngs in the forest. After 1799 he had no official relation to the ministry of the Methodist church, but continued to adhere to and to preach the prominent doctrines of that communion till his death. During his latter years his efforts were more specially directed against the Jesuits, whom he regarded as dangerous enemies to pure religion and to republican government." Among his numerous writings are: "Polemical Works" (12mo, New York, 1814); "The Stranger in Charleston, or the Trial and

Confession of Lorenzo Dow" (Philadelphia, 1822); "A short Account of a long Travel, with Beauties of Wesley" (8vo, Philadelphia, 1823); and "History of a Cosmopolite, or the Writings of the Rev. Lorenzo Dow, containing his Experience and Travels in Europe and America up to near his fiftieth Year; also his Polemic Writings" (often reprinted).

**DOWER** (law Lat. *doarium*, or *douarium*; Fr. *douaire*), the estate which the wife has by operation of law in the property of her deceased husband. Strictly it applies only to what the law gives her independent of any act of the husband, and which, in fact, it is not in his power to bar. A marriage portion, therefore, whether given with the wife or secured to her use, and whether so given or secured by the father or other relative, or by the husband himself, is not dower; and yet the term by which such marriage portion was designated in the Roman law (*dos*) was used by Bracton and other English writers for the right of the widow in the lands of her deceased husband given to her by the common law, as well as the endowment in contemplation of marriage, which last was also called *donatio ante nuptias*. The English word dower expressed the former, and also the donation before marriage, which was in two modes, viz.: *ad ostium ecclesie* and *ex assensu partis*. Both of these were made at the porch of the church, after affiance and before marriage; in the one, the husband endowed the wife of lands of which he was himself seized; in the other, with consent of his father, he endowed her of lands belonging to his father; and it was usual to specify the particular lands intended. Endowment at the church door was the common mode of providing for the wife in the time of Bracton (13th century), and no other could be substituted, as by will or any other conveyance; the object of which was to prevent fraud: *Non enim valent facta in lecto mortali, nec in camera, aut alibi ubi clandestina fuerunt conjugia*. The feudal restriction against alienation of lands was extended to dower, and the husband was not allowed to endow the wife *ad ostium ecclesie* of more than a third part of his lands. This gave rise to the common law rule which has ever since prevailed. In the absence of such dotation, or in case of the omission to specify the particular lands, it was prescribed that the wife should be entitled to one third of the lands of the husband for life if she survived him, which was called *dos rationabilis*. It was at first limited to the lands which the husband had at the time of the dotation, unless he specially charged his future acquisitions; and in case he had no lands, or not sufficient, he was permitted to endow his wife of personal property, which was held to be a bar against any claim to dower of lands thereafter acquired. But in Magna Charta it was provided that the wife should have for dower the third part of all the lands which the husband had held during his lifetime, unless she had been

endowed with less *ad ostium ecclesie*. In the reign of Henry IV. it was denied that the wife could be endowed of her husband's goods and chattels; and Littleton, who wrote in the reign of Edward IV., asserted that she could be endowed *ad ostium ecclesie* of more than a third part of the lands, and that she had the election after the husband's death to accept it or to take her dower at common law. In consequence of this uncertainty, that mode of endowment fell into disuse, but was never abolished until by act 3 and 4 William IV., c. 105 (1833). Dower at common law is different from the dotation of other countries, in being limited wholly to lands, and to such only as the husband holds in fee. By the civil law the *donatio ante nuptias* (or, as Justinian called it, *propter nuptias*) was all the provision made for the wife. It might consist of either lands or personal property; but though it went into the possession of the husband, it could not, if it consisted of lands, be alienated by him even with the consent of the wife, for which the reason given is the fragility of the female sex (*ne sexus muliebris fragilitas in perniciem substantiæ earum convertatur*). Upon the death of the husband, or dissolution of the marriage otherwise, the wife only took what had been given with her on the marriage, or that of which a donation had been made during the marriage. Of the other property of the husband she could take nothing either as widow or heir.—In France, the two modes of providing for the wife are designated by the discriminative terms *dot* and *douaire*; the former of which is defined to be that which the wife brings in marriage; the latter is the right which the wife has, by custom or matrimonial contract, to a certain portion of the estate of the husband upon his death. The origin of *douaire* was that in some provinces of France, called *France coutumière*, women were not endowed on marriage; and hence grew up the custom that the husband at his death should leave something for the support of the wife. What was so left was called either *dot* or *douaire*, the wife being said to be *douée* or *dotée*. But as it was intended for her support merely, it was provided that after her death it should go to the husband's children if he left any. Philip Augustus fixed the dower of the wife at one half of the goods which the husband had at the marriage. Henry II. of England established in his French provinces a rule that dower should be one third, and this difference continued to exist on the opposite sides of the Loire, until the customary law was swept away by the legislation which succeeded the revolution of 1789. By the present law of France married persons may, by stipulation made before marriage, become subject to the law of community, or to the law of dowry. If the former, it brings into common stock all the movables of which the parties are possessed at the time of marriage, and the immovables which shall be acquired during marriage.

Dower (*la dot*) is what the wife brings to the husband in marriage, and it may be either by donation from another or by a settlement of the wife upon herself, and it may extend to all the present or future property of the wife, but cannot be constituted or augmented during marriage. The parties may stipulate for a community of future acquisitions only. The husband has the management of dotal property, but is accountable as a usufructuary, and in case it be put in peril, the wife may obtain a separation of goods.—The English law of dower has recently undergone very great changes. By statute 3 and 4 William IV., c. 105, the widow is not entitled to dower of lands which the husband has disposed of in his lifetime, or by will. All charges by will, and all debts and encumbrances to which the estate of the husband is subject, take priority of dower; and dower is made subject to any restrictions which the husband may impose by will. But on the other hand, the wife is entitled to equitable dower of any beneficial interest of the husband which shall amount to an estate of inheritance in possession, except joint tenancy; and no gift of personal property by the husband can invalidate the right to dower, unless expressly so declared by will. This modification of the law of dower has probably grown out of the general custom prevailing in England among land proprietors of making marriage settlements. In cases where this is omitted, the wife still has some provision under the statute of distribution (29 Charles II.), which gives her one third of the personal estate of the husband when he dies intestate, not for life merely, but absolutely.—In the United States, the general rule prevails of allowing to the widow an estate for life in one third of all the lands of which the husband was seized in fee. To give the right, however, the seisin of the husband must be a beneficial one, and not merely as trustee or for the use of another, and the marriage must be legal, or if voidable, must not have been set aside during the husband's life. The wife may be barred of her dower in various modes; as: 1, by an old statute of Edward I., which has been recognized in some of the states and not in others, elopement from the husband, and living with an adulterer; 2, acceptance of a jointure or of a provision made by will in lieu thereof; 3, divorce, for in general the marriage must continue until the husband's death, though in some states it is provided that if divorce is had for the husband's misconduct, the wife shall be immediately endowed as if he were dead; 4, joining with the husband in a conveyance of the lands under the statute formalities. This last is the most usual mode, but if the conveyance be by way of mortgage, the wife shall have dower subject to the mortgage. Dower should be assigned to the widow by the husband's heir or alienee within the widow's quarantine, which originally was 40 days, but now by statutes is greatly enlarged, during

which she may continue to occupy the mansion house; but if he fail to do so, or make an assignment which she thinks unjust, she may recover by suit. The profits issuing out of lands are subject to dower, as well as the lands themselves, and assignment of dower in such cases is made by setting out one third the annual proceeds during the widow's life. The law of dower has recently undergone many changes in different states. In several the wife now has dower only in the lands of which the husband died seized; in others, though the husband's several conveyance does not bar dower, a judicial sale for the enforcement of a debt or a contract against him will do so; in others still the estate is enlarged and made an estate in fee, instead of for life only. The share which the widow takes in the personal property is not called dower, and there is no uniformity in the statutes on that subject.

**DOWLER, Bennet**, an American physician and physiologist, born in Ohio co., Va., April 16, 1797. He was educated at the university of Maryland, where in 1827 he received the degree of doctor of medicine. In 1836 he settled in New Orleans, and was for several years the editor of the "New Orleans Medical and Surgical Journal." From an early period in his career experiments upon the human body, immediately or very soon after death, occupied a large share of his attention, and the results of his investigations, comprising some important discoveries with regard to contractility, calorification, capillary circulation, &c., were published in 1843-'4. Since that time these and other original experiments have been extended, generalized, and analyzed by him. His researches on animal heat, in health, in disease, and after death, which have from time to time been published in medical journals, have led to important discoveries, particularly with reference to *post mortem* calorification, which his experiments have shown will, after death from fever, cholera, or sunstroke, &c., rise in some cases much higher than its antecedent maximum during the progress of the disease. In 1845 Dr. Dowler commenced a series of experiments in comparative physiology on the great saurian or alligator of Louisiana, which he regarded as better for the purpose than any of the cold-blooded animals usually selected for vivisection. From these experiments he was led to the conclusions that after decapitation the head, and more especially the trunk, afford evidences of possessing the faculties of sensation and volition for hours after a complete division of the animal; that the headless trunk, deprived of all the senses but that of touch, still retains the powers of perception and volition, and may act with intelligence in removing or avoiding an irritant; and that the functions and structures of the nervous system constitute a unity altogether inconsistent with the anatomical assumption of four distinct and separate sets of nerves, and a corresponding fourfold set of functions.



**DOWLETABAD**, or *Deoghir* (the fortunate city), a town and fortress of Hyderabad, Hindostan, about 7 m. N. W. of Aurungabad. The fortress is on a hill 500 ft. high, about 150 ft. of which is nearly perpendicular. The entrance

**DOWNES, John**, an American naval officer, born in Canton, Mass., in 1786, died in Charlestown, Aug. 11, 1855. He entered the navy as a midshipman in June, 1802, and was in the frigate *New York* during the war with Tripoli.

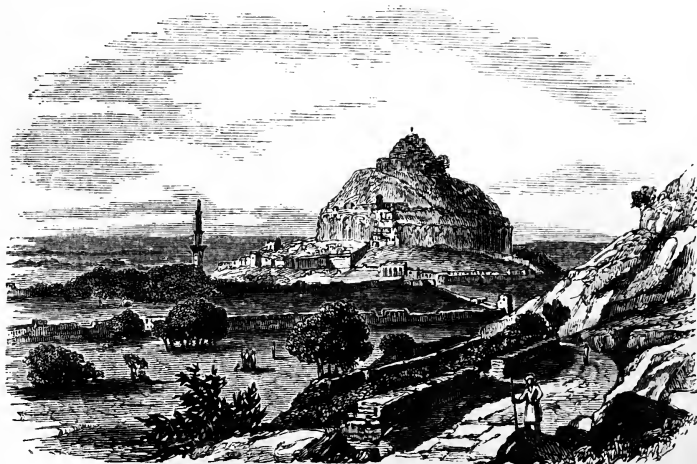

Dowlatabad.

is by a narrow passage cut through the rock. Notwithstanding its natural strength, the fortress has been taken several times, and has belonged to various masters. Near the town are the remarkable cave temples of Ellora.

**DOWN**, a N. E. county of Ireland, province of Ulster, bordering on the Irish sea and the counties Antrim and Armagh; area, 956 sq. m.; pop. in 1871, 277,775. Near the middle of the county is a group of hills, and in its S. W. part are the Mourne mountains, some of whose summits are among the highest peaks in N. Ireland; but with these exceptions the surface is generally level. There are several rivers, but only the Lurgan, which flows along the northern boundary, and the Bann, are important. All the streams and the lakes, which are numerous, abound in fish. Lough Strangford in the E. part is a large inlet of the sea, with which it communicates by a deep channel. The county contains many mineral springs, and is one of the best cultivated counties of Ireland, producing grain, peas, beans, potatoes, turnips, &c. Cattle, chiefly for dairy purposes, and hogs are reared in great numbers. There are extensive quarries of limestone, sandstone, and slate; and granite, coal, and chalk also occur. The most important manufacture is that of linen, though there are also cotton and woollen mills. The climate is healthy and somewhat cold, and the people generally are in better condition than those of most Irish counties. Fishing occupies many of the inhabitants. Some interesting and very ancient remains are found, and there are ruins of abbeys and castles of the middle ages. The chief towns are Downpatrick, the capital, and Newry.

In May, 1803, he distinguished himself in a boat attack upon some Tripolitan feluccas. In March, 1807, he was made lieutenant, and in the war of 1812 he served as executive officer of the frigate *Essex*, Capt. Porter, during her celebrated cruise in the Pacific. Among her numerous prizes was the whale ship *Georgiana*, which Capt. Porter fitted as a cruiser, with 16 guns, named the *Essex Junior*, and placed under the command of Lieut. Downes, who retained this position until the capture of the *Essex* and the

conversion of the *Essex Junior* into a cartel. In 1813 he was promoted to the rank of master commandant, and in 1815 he commanded the brig *Epervier* in the squadron employed against Algiers under Decatur. On June 17, 1815, the *Epervier* assisted in the capture of the Algerine frigate *Mashouda* off Cape de Gatt. Two days afterward the *Epervier* and three of the smaller vessels of the squadron captured the Algerine brig of war *Estido*, 22 guns and 180 men, off Cape Palos. After the conclusion of peace with Algiers, Decatur transferred Downes to his own ship, the *Guerriere*. In March, 1817, he became captain, and from 1819 to 1821 commanded the frigate *Macedonian* in the Pacific. In 1828-9 he commanded the *Java* in the Mediterranean, and from 1832 to 1834 the squadron in the Pacific. On his way to his station he attacked (Feb. 6, 1832) and nearly destroyed *Quallah Bato*, on the coast of Sumatra, where an outrage had been committed on an American vessel. His sea service terminated with his cruise. From 1837 to 1842, and from 1850 to 1852, he commanded the navy yard at Boston.

**DOWNING, Andrew Jackson**, an American landscape gardener, born in Newburgh, N. Y., Oct. 30, 1815, drowned in the Hudson river, near Yonkers, July 28, 1852. From an early age his tastes were directed to horticulture, botany, and the natural sciences, which the occupation of his father, a nurseryman, gave him many opportunities to cultivate. His school education was acquired chiefly at an academy in the neighboring town of Montgomery. He returned home at the age of 16 to assist an elder brother in the management

of the nursery, but continued a course of self-education which gave him a broad general culture. At the age of 20 he determined to become a rural architect, and began to visit the neighboring estates on the Hudson, to enlarge his experience and confirm his theories of landscape gardening. Three years later he erected, on his estate an elegant mansion, which afforded the first practical illustration of the builder's conception of an American rural home. His career as an author properly begins with the publication in 1841 of his "Treatise on the Theory and Practice of Landscape Gardening." As a pioneer of its class in this country, it attracted attention, and the author's extensive information, correct taste, and appreciation of the conditions of rural architecture, gave it immediate popularity and a position as a standard authority, both in America and England. "Cottage Residences" (1842) was received with equal favor; and until his death Downing continued to be the chief American authority in rural art. In 1845 appeared simultaneously in London and New York his "Fruits and Fruit Trees of America;" and in 1846 he became editor of the "Horticulturist," published in Albany, for which he wrote an essay every month until the close of his life. In 1849 he wrote "Additional Notes and Hints to persons about building in this country," for an American reprint of Wightwick's "Hints to Young Architects," and in 1850 published his "Architecture for Country Houses." His remaining work was an edition of Mrs. Loudon's "Gardening for Ladies." The summer of 1850 he passed in England, chiefly among the great country seats, of which he wrote descriptions. On his return to America he received many private commissions, and was intrusted in 1851 with the laying out of the public grounds in the city of Washington, in the vicinity of the capitol, the president's house, and the Smithsonian institution. In the midst of these labors he took passage at Newburgh on July 28, 1852, in the steamboat Henry Clay, for New York. Near Yonkers the boat took fire, and he was drowned in endeavoring to reach the shore. A memoir of him by George W. Curtis, and a "Letter to his Friends," by Miss Bremer, who had been his guest during her visit to America, were prefixed to a collection of his contributions to the "Horticulturist," published in 1854, under the title of "Rural Essays."

**DOWNPATRICK**, a maritime town and parliamentary borough of Ireland, capital of county Down, situated a short distance from the mouth of the Quoyle in Lough Strangford, 21 m. S. S. E. of Belfast, with which it is connected by rail; pop. in 1871, 4,154. It is divided into English, Irish, and Scotch quarters, has a cathedral and the diocesan school of the Anglican diocese of Down, Roman Catholic, Presbyterian, and Methodist places of worship, a county court house, prison, infirmary, and fever hospital. Near the town is a

new lunatic asylum. A small export trade is carried on by means of vessels of 100 tons from Lough Strangford. It has manufactures of leather, linen, soap, and beer. The four holy wells of St. Patrick, to which pilgrims resort from all parts of Ireland, are near the town. Downpatrick is said to be the oldest city of Ireland, and was the chief residence of St. Patrick.

**DOWSE, Thomas**, an American book collector, born in Charlestown, Mass., Dec. 28, 1772, died in Cambridgeport, Nov. 4, 1856. He has sometimes been called "the literary leather dresser." His father, Eleazer Dowse, was a leather dresser, and was driven with his family from Charlestown on June 17, 1775, his house being one of those burned. He settled at Sherborn, Middlesex co., where Thomas spent his boyhood and youth. He had no other education than that of the town school. On attaining his majority he entered the service of a leather dresser at Roxbury, Mass., and remained in this employ ten years. He once informed a friend that at the age of 28 his highest income was \$25 a month; that he had never paid \$5 for conveyance from one place to another, never owned a pair of boots, and then possessed several hundred volumes of good books well bound. In 1803 he set up in business at Cambridgeport as a leather dresser, and pursued the occupation successfully till he was far advanced in life. From the earliest period he devoted a large part of his income to the purchase of books. By diligent search, great knowledge of bibliography, shrewdness, and strict economy in his purchases, he amassed a very remarkable library. It consisted of about 5,000 miscellaneous volumes, generally in good, often in elegant bindings, and of the best editions. It was mostly English, though containing translations of the principal authors in the ancient languages and the cultivated languages of modern Europe. It is estimated to have cost \$40,000. He bequeathed it to the Massachusetts historical society, who deposited it in a special room of their building in Boston. He also left \$10,000 as a permanent fund for the conservation and care of the library. A collection of admirable engravings and water-colors, which he drew in a lottery about 1820, was given to the Boston Athenæum.

**DOXOLOGY** (Gr. *δόξα*, glory, and *λέγειν*, to ascribe), in general, an ascription celebrating the grandeur and majesty of God. In the Roman Catholic church it is applied particularly to the angelic hymn or canticle of praise which is sung in celebrating the mass, and is otherwise called the *Gloria in excelsis*. This is also styled the greater doxology, to distinguish it from the lesser, or *Gloria Patri*, which is usually sung after the chanting or recitation of a psalm. Both doxologies are traced to the earliest periods of the church, and, though slightly and temporarily modified during the prevalence of some heresies, have not been permanently changed. They both have a place in

the liturgy of the Anglican church, and are of common use in the service of other branches of Protestantism.

**DOYLE, Richard**, an English artist, born in London in 1826. From his father, John Doyle, an able political caricaturist, he inherited a taste for humorous illustration, and a few years after the establishment of "Punch" became known to the public by his designs published in that paper. His political caricatures are singularly free from direct personalities, but his humorous illustrations of London life afford the best examples of his harmless wit and graceful fancy. The series entitled "Manners and Customs of y<sup>e</sup> Englyshe," though ostensibly caricatures, are in fact sketches of the everyday life of the people. The "Continental Tour of Messrs. Brown, Jones, and Robinson" is a somewhat exaggerated view of the lights and shadows of travel on the continent. In 1850, taking umbrage at the very severe attacks of "Punch" upon the Roman Catholic hierarchy, Doyle severed his connection with that paper, since which time he has employed his pencil chiefly in illustrating books of fairy tales and similar publications, including "The Fairy Ring," "Fairy Tales from all Nations," Leigh Hunt's "Jar of Honey," Ruskin's "King of the Golden River," &c. He also illustrated "The Newcomes" of Thackeray. In 1869 he published a Christmas book entitled "In Fairy Land: Pictures from the Elf World."

**DOZY, Reinhart**, a Dutch orientalist and historian, of French extraction, born in Leyden, Feb. 21, 1820. He studied in Leyden, where he graduated in 1844, and has been since 1850 professor of history. His principal works are: *Recherches sur l'histoire et la littérature d'Espagne pendant le moyen-âge* (2 vols., Leyden; 2d ed., 1860), in which he exposed the falsifications of the monkish chroniclers; *Al-Makkari* (with Dugas, Krehl, and Wright, 2 vols., 1855-'61); *Histoire des Musulmans d'Espagne jusqu'à la conquête de l'Andalousie par les Almoravides* (4 vols., 1861); *Het Islamismus* (Haarlem, 1863); and *Scriptorum Arabum Loci de Abbaditis* (3 vols., Leyden, 1846-'63).

**DRACHENFELS** (Dragon's Rock), the most celebrated of the Siebengebirge range or "seven hills" (though their number is really greater), on the right bank of the Rhine, near Bonn. The ascent of the steep mountain, which is about 1,050 ft. high, amply rewards

the traveller by the beauty of the scenery of the river and valley and of the adjoining panorama of ruin-clad mountains. On the summit of the Drachenfels are the ruins of a castle of the 12th century, and two monuments of the services of the Siebengebirge militia in the struggle of 1813-'15. Here also is a quarry which has furnished stone for the cathedral of Cologne, and hence called *Dombruch* (cathedral quarry).

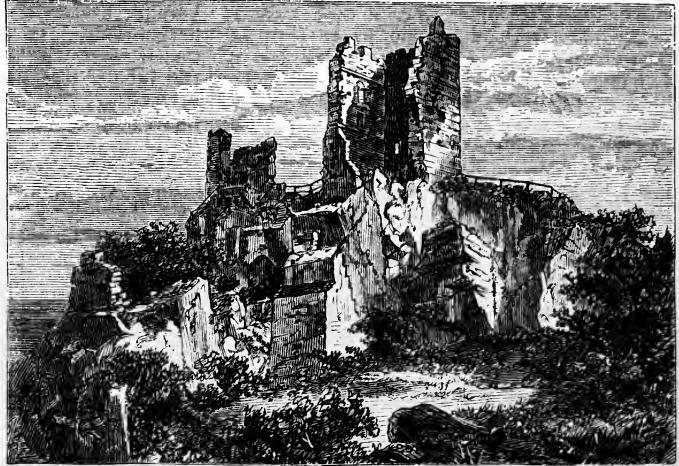

Ruins on the Drachenfels.

The beauty of this mountain has been a fruitful theme with poets of every land. Its name is explained by a tradition of a dragon which inhabited a cavern in its sides, and was slain by Siegfried, the hero of the Nibelungen lay.

**DRACHMA**, a measure both of weight and value among the ancient Greeks. In either case it was composed of 6 oboli, and was the  $\frac{1}{100}$  part of the mina, and the  $\frac{1}{10000}$  part of the Attic tal-



Athenian Drachma (exact size).

ent. The drachma was the principal silver coin of the Greeks, and its value was from 15.20 to 17.05 cents. The drachma or drachm mentioned by Jewish writers was the Greek coin, which became current among the Jews in the latest period of their national existence.

**DRACO**, the author of the *Θεσμὸι*, the first written code of laws at Athens, which he is supposed to have published in the 39th Olympiad (beginning 624 B. C.). Almost nothing is known of his life, but he appears to have been of distinguished birth and virtue, honored for his severe manners and his large experience in public affairs. The exact incidents

which led to the formation and adoption of his code are unknown. It is the opinion of most writers that he framed it in accordance with a spontaneous demand of the people, who were weary of lawlessness. He took the citizen at the moment of his birth, prescribed the manner in which he should be nourished and educated, and followed him with directions through the epochs of life. The penalty of death was to be inflicted for almost every crime. The slightest offence, he said, deserved death, and he knew no punishment more severe for the greatest. He carried his severity to a fantastic extreme, ordering punishment to be inflicted upon a statue whose fall had injured a man. So violent a code could not last, and within 30 years Athens was again in anarchy. Draco died at the culmination of his glory, upon the isle of Ægina. Suidas says that as he entered the theatre there and received the acclamations of the people, he was stifled amid the mass of caps, robes, and cloaks, which in accordance with custom they threw upon him as a mark of honor.

**DRACUT**, a town of Middlesex co., Mass., on the N. bank of Merrimack river, opposite Lowell, with which it is connected by two bridges; pop. in 1870, 2,078. It borders on New Hampshire, and is traversed by Beaver river, which supplies it with water power. It is mainly an agricultural town, but contains two woollen mills, one of which has 19 sets of cards, 82 looms, and a capital of \$500,000. There is also a paper mill.

**DRAGOMAN**, an oriental word signifying interpreter. It is applied, in the Ottoman empire and the courts of the further East and of Barbary, to men who know several languages, and act as interpreters between foreigners and the natives. What was formerly a necessity for commercial relations, has since become so for purposes of diplomacy. At Constantinople the office of prime dragoman, through whom the sultan receives the communications of Christian ambassadors, is one of the most important of the Sublime Porte. Dragomans are also attached to each of the foreign legations at oriental courts, and as such they enjoy the privileges of diplomatic officers. The French government trains a number of young men to fill these positions.

**DRAGON**, an animal often alluded to in the Bible, supposed by some to be the crocodile, and by others to refer in some passages to a species of giant serpent, or to a wild beast like the jackal or wolf. According to Robinson's Calmet, it is not improbable that St. John had in mind the enormous boa of Africa and the East when he described the symbolic great red dragon.—In mythology, the dragon is a fantastic animal, variously represented as of immense size, with wings, thorny crests, powerful claws, and a snaky tail and motion. He figured in the ancient conceptions of the Orient and of the classical nations, was a familiar subject in the middle ages, is still an emblem of universal

use among the Chinese, and seems to have existed almost everywhere except in nature. The pterodactyl and ramphorhynchus of the mesozoic age, though probably extinct long before the era of man, would have furnished excellent foundations for the dragon of tradition.

**DRAGON** (*draco*, Linn.), an iguanian lizard of the subfamily of acrodonts, or those having the teeth implanted in the bony substance of the jaws, to which they firmly adhere by the base of the roots. The head is triangular, flattened, and covered with small irregular scales, sometimes ridged; the small circular and tubular nostrils open at the end of the obtuse snout; the tongue is thick and spongy, with a round single extremity; the anterior teeth are three or four, and resemble incisors; behind these the median ones are conical, like canines, and there are generally two pairs in each jaw; the posterior teeth, or molars, are tricuspid and compressed; under the neck is a long dewlap, and on each side a triangular cutaneous fold placed horizontally, all three having in their thickness a process from the hyoid bone; there is generally a small cervical crest.

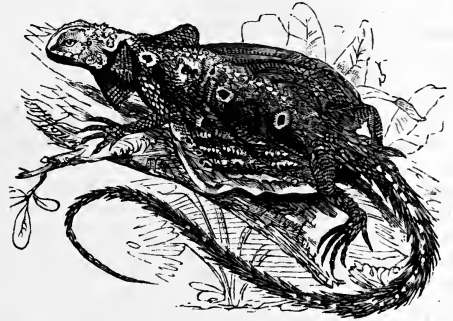

*Draco fimbriatus.*

While some species have no external ear, in others there is a small circular membranous tympanum. The neck is slightly compressed; the body has a central dorsal depression, and is covered above and below with small imbricated ridged scales. Dragons are at once distinguished from all other reptiles of this order by the horizontal expansion of the skin of the sides into a kind of wing, supported chiefly by the first six false ribs, which are extended horizontally outward. This flying membrane is semicircular, about as wide as the arm is long, free in front, but attached behind to the interior part of the thigh; in a state of rest the animal keeps it folded like a fan along the body, and when leaping from branch to branch spreads it like a parachute to sustain it; it cannot be moved as an active organ of flight, like the wing of a bird or the membrane of the bat. The fore and hind limbs, each with five toes, are of about the same length, the latter being flattened, with the posterior border fringed with serrated scales; there are no femoral pores; the tail is very long, slender,

wide and flat at the base, round at the end, with rhomboidal imbricated scales, strongly ridged beneath. Among the species with a visible tympanum, and the nasal openings directed laterally, are: 1. The fringed dragon (*D. fimbriatus*, Kuhl), with the thighs fringed behind with triangular scales, and with longitudinal white lines on the wings; the general color above is an olive gray with shades of brown in transverse bands, and whitish below; this is the largest species described by Duméril and Bibron, the total length being about 11 in., of which the body is only 3; it is peculiar to Java. 2. The flying dragon (*D. Daudinii*, Dum.), from Java, grayish above with black spots, and the wings marbled with the same; total length about 9 in. Several other species are described from the East Indies. There are two species which have the tympanum concealed under the skin, constituting the genus *draconculus* of Wiegmann; these are the lined dragon (*D. lineatus*, Daudin) of Amboyna and Celebes, about 6½ in. long, with the back ash-colored, and the wings grayish brown with longitudinal white lines; and the Philippine dragon (*D. spilopterus*, Wiegman.), from the neighborhood of Manila, about 8½ in. long, with red wings spotted with black or brown, and throat yellow with black dots. Dragons live almost entirely in trees and feed upon insects, which they catch with great dexterity.

**DRAGONETTI, Domenico**, an Italian contrabassist, born in Venice, April 7, 1763, died in London in 1846. His father was a player upon the double bass, and the young Dragonetti made such progress upon the instrument as to be regarded as a prodigy at the age of 13. He was the first to make a solo instrument of the unwieldy double bass. At the age of 24 he took up his residence in London, where he remained during the rest of his life as first double bass in the royal theatre and at the philharmonic concerts. He was esteemed the most accomplished player upon his instrument of his time, and wrote for it many pieces in which were introduced passages that hitherto had been deemed practicable only for the violin. The instruments that he played were a superb Gasparo da Salo and a Stradivarius.

**DRAGON FLY** (*libellula*, Linn.), an insect of the family *subulicornes* of Latreille, or *odonata* (Fabr.), and the order *neuroptera*. The insects of this genus, called in this country "devil's darning needles," in the perfect form are light and graceful fliers, of the most brilliant and beautiful colors, with four large, shining, delicate wings of nearly equal size; the mouth is provided with strong horny mandibles and spiny maxillæ; the eyes are lateral, large, and brilliant, with three stemmata on the top of the head; the antennæ consist of from three to six joints; the legs are short, six in number, directed forward, arising from a firm thorax of three united segments; the abdomen is very long, a flattened cylinder, soft, without sting

or piercer, and in the males terminated by two lamellar appendages. In some genera the male sexual organs are placed in the second abdominal ring, and those of the female in the last ring; the female deposits her eggs on aquatic plants beneath the surface of the water. From their lightness and beauty the French call them *demoiselles*. They are among the most voracious and cruel of insects, darting with swiftness and ferocity upon gnats, mosquitoes, butterflies, and almost any soft-bodied winged insect, eating even their own species. They are in no way injurious to man, but are directly beneficial in destroying many noxious insects. They hover over pools in search of prey, or dart from a post or fence upon insects coming near. They are equally carnivorous in the larva state, which they pass in the water. The larvæ have six feet, and a very complicated arrangement of the parts forming the under lip, which covers the face like a mask, concealing the mouth; they crawl stealthily along the bottom, and spring their jointed mask upon insects and even small fishes with great precision. By a valvular apparatus at the end of the tail, they draw in and expel water, as a means of locomotion. They remain several months in the water, and change their skins several times. The nymphs have rudimentary wings, and when they are ready to assume their final change the brilliant eyes of the future fly may be seen through the envelope; they crawl out of the water upon some bank or aquatic plant, where the pupa skin becomes dry and crisp and bursts open on the back. During the drying of the wings the insect bends the body into a crescent, that the delicate tissue may not be disturbed by contact with any foreign substance. The anterior nervures of the wings must be very strong, though light, to permit the rapid vibrations of these organs; their section, as in the butterfly, presents the form found by engineers to be that of the beam of greatest strength and lightness, viz.: the greatest amount of material thrown into the oval



*Libellula trimaculata.*

flanges, connected by the thinnest possible median support. According to Drury, these insects are two years in reaching the perfect form from the egg; after flying about a few

weeks, and having performed the act of reproduction, the wings become ragged, the strength fails, and they soon die. M. Poey says that at certain seasons the north winds sweep hosts of them into the neighborhood of Havana; in Belgium in 1854 a swarm was seen extending three quarters of a mile, the lowest individuals flying at a height of about six feet.—The restricted genus *libellula*, of which nearly 20 species inhabit New England, has a flattened, moderately long body, an almost globular head, the eyes contiguous or approximate, and the wings horizontal when at rest. The larvæ are short and thick, rough and of a dirty color; they have five appendages to the tail. The genus *ashna* (Fab.) includes the large species, with long slender bodies, which keep the wings expanded when at rest; the larvæ are larger, long and slender, with the abdomen flat below and rounded above; this includes the *L. grandis* (Linn.), the largest and most predaceous of the British genera; there are about a dozen species in Massachusetts. In the genus *agrion* (Fab.) the



Agrion.

wings are perpendicular during repose, the head transversal, and the eyes far apart; this includes the species with the slender and filiform abdomen, sometimes of extraordinary length; the larvæ are small, with round slender bodies terminating in three feathery appendages; there are about ten northern species well known, many of them delicate and beautiful; among the foreign species are some of the most brilliant of insects. Many of the finest American species of this family are described and figured by Drury.

**DRAGON'S BLOOD**, a resinous substance obtained from the fruits of several small palms in the East Indies, from the trunk of *dracæna draco*, a large tree growing in the Canary Islands and Azores, and from *pterocarpus draco*, a tree of the West Indies and South America. It occurs in oval masses, sticks, and disks. It is inodorous and tasteless, insoluble in water, but soluble in alcohol, ether, and the volatile and fixed oils, with which it forms red solutions. It was formerly employed in medicine as an astringent, but is nearly or quite inert. It is sometimes used to impart color to plasters,

but is valued chiefly as an ingredient of paints and varnishes.

**DRAGUIGNAN**, a town of France, capital of the department of Var, 41 m. N. E. of Toulon; pop. in 1869, 9,819. It lies in a fertile valley, surrounded by high hills covered with rich vineyards, and is well built, with several elegant edifices and numerous fountains. It contains a library of about 20,000 volumes, a cabinet of medals and of natural history, law courts, a botanic garden, a communal college, and a fine clock tower. The inhabitants are employed chiefly in the silk mills and soap works of the environs, and in preparing and selling olive oil. Draguignan was founded in the 5th century. It suffered greatly in the religious wars of the 16th and 17th centuries.

**DRAINAGE**, the art of freeing land from superfluous water by causing it to flow off in channels or through porous substances. The system of drainage adopted for cities and towns will be treated in the article **SEWERAGE**. The art is of especial interest in its application to the reclaiming of wet lands, and the improvement of those through which water does not find a ready exit. The ancient Romans constructed open drains for conveying the superficial water from their lands. In England, public attention was directed to the injurious effects of water retained in cultivated lands by the treatise of Capt. Walter Blyth in 1652. The author condemned the shallow open drains in common use, and recommended straight trenches reaching below the spring of "cold, spewing, moyst water," which he regarded as the source of the "corruption that feeds and nourisheth the rush or flagg," even to the depth of three or four feet, and the filling in of the trenches with stones, or fagots covered with turf. It was long before the excellence of this system was generally recognized, and little attention appears to have been directed to it until the latter part of the next century. About the year 1764 a farmer of Warwickshire, Mr. Elkington, discovered that when an impervious stratum beneath the soil was perforated, the water welled up and flowed away; and he hence inferred that the water in wet lands came chiefly from subterranean sources, and might be removed by tapping the stratum that confined it. On this theory he established an original system of drainage, and was remarkably successful in seeking out the sources of the water, which, after reaching by an auger, he drew off in a single deep channel. This system came into extensive practice in England and Scotland, and its imperfections were not fully appreciated till after the introduction of the system of James Smith of Deanston, in 1823. This was contrived with reference to the removal of the water on the surface, as well as that beneath the soil, and was in fact the practice recommended nearly 200 years before by Capt. Blyth. A series of parallel drains were sunk in the direction of most rapid descent, and, being par-

tially filled with stones small enough to pass through a three-inch ring, were covered over with soil. At the bottom a main drain was constructed, generally in stone work or with tiles. The new practice met with great opposition from the advocates of Elkington's method, but finally came to be regarded as the only complete system applicable in all cases. In some instances the other plan may no doubt be economically adopted. The drains came at last to be made chiefly of tiles, for the manufacture of which the first machine was invented by the marquis of Tweeddale. The practice has been successfully introduced into the United States, and drain tiles are now a considerable branch of manufacture.—Wet lands are well known to be unfavorable to the production of large crops; it is also true that grains, potatoes, grass, &c., are sounder and better when raised upon lands not subject to excess of moisture. The soils that retain it are correctly described as cold, while the more porous soils are called warm. From the experiments of Mr. Parkes in a bog in Lancashire, it appears that by giving free passage to the water through a cold soil by thorough drainage, its temperature at the depth of seven inches may be raised  $10^{\circ}$  above that of undrained adjoining land of the same quality. Thus drainage produces the effect of a warmer climate, and may add in fact many days to the season; and this not merely by reason of the warmth extended for a longer period, but in the spring the soil is sooner prepared for cultivation, and may be in condition for ploughing and planting even two weeks before neighboring land of similar quality in other respects would admit of working. While frequent accession of water is a great benefit to lands through which it finds a ready passage, its retention impairs in various ways the fertility of the soil. It prevents the pulverization of the earth by the plough and harrow, and the circulation of air to the roots of the plants. It nourishes a growth of noxious plants, and in woodlands its injurious effect is seen in the production of many lichens, fungi, and other parasites upon the trees. Open ditches may be made in the lower grounds, where natural streams are not convenient for receiving the drainage from the underground ditches, which are made by laying tiles in trenches and covering them with soil. A section of an underground drain is represented in fig. 1. Sometimes coarse stones are used, but tiles are preferable on account of their less liability to become clogged. Several kinds of tile are made, each being suitable under certain circumstances. They are from 3 to 10 in. in diameter, and from 1 to 2 ft. in length. They are made of nearly the same kind of clay as brick, and are baked sufficiently to include as much porosity and toughness as possible. The different forms generally in use are represented in fig. 2. Any variety may be large or small. The horseshoe tile may be laid upon flagging or

boards, and all of them should be placed deep, out of the way of frost and the plough.—In Europe the largest draining operations have been those for reclaiming immense tracts

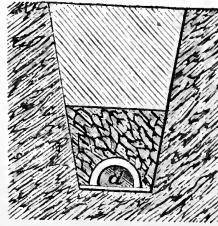

FIG. 1.—Section of an Underground Drain.

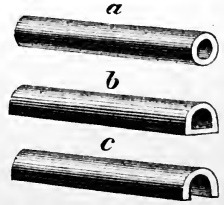

FIG. 2.—a. Pipe tile. b. Sole tile. c. Horseshoe tile.

of submerged or boggy lands, some of which were altogether below the level of natural drainage. As early as 1436 attention was directed in England to the possibility of reclaiming the fens bordering the river Ouse and its tributaries, now known as the Bedford Level. These covered an area of about 400,000 acres, which in ancient times appears to have been in a condition for cultivation. The tract presents but very limited natural channels for conveying the water into the sea on the northeast. The attempt to embank and deepen these in the 15th century was unsuccessful, but it was renewed by the earl of Bedford in 1634. In three years he expended £100,000 in embankments for keeping out the waters of the rivers, and removing those within by pumping. This attempt also failed; but in 1649 his son recommenced operations, and succeeded after an expenditure of £300,000 more. From that time the lands reclaimed have been kept free from water by machinery worked by windmills. Among the numerous drainage channels cut through these lands are two nearly parallel, more than 20 m. in length, and both navigable, serving to cut off a long circuitous reach of the river Ouse. By other direct channels made during the present century above the outlet of the same river, and also of the neighboring river Nene, many thousand acres more have been reclaimed. The steam engine has been advantageously substituted in many instances for the windmills; and it has been found practicable to estimate closely the power and expense required to keep an area of given extent thoroughly drained. The annual fall of rain averaging 26 in., there would be, with a very moderate allowance for evaporation, 2 in. per month of water to be raised, or  $1\frac{1}{2}$  cubic feet of water as a maximum on every square yard of surface. The amount on an acre, 7,260 cubic feet, may be raised 10 ft. and discharged in about 2 hours and 10 minutes by the power of one horse. A steam engine of 10-horse power could then each month raise to the same height and discharge the water from 1,000 acres in 232 hours.—The drainage of Haarlem lake in Holland, undertaken in 1839, was a gigantic

operation of this class. From an area of 70 sq. m. of average depth of water of 12½ ft., situated below the level of any sluices that could be constructed, it was required to raise the water an average height of 16 ft., and to an estimated possible amount of 35,000,000 tons in a month. An enormous steam engine was constructed in London for working 11 pumps of 63 in. diameter each and 10 ft. stroke, the maximum capacity of all which was to raise 112 tons of water 10 ft. at each stroke. These were set around the circular tower which contained the engine, and from the upper portion of which the balance beams radiated, one for each pump. They raised in actual work 66 tons per stroke, discharging the water in a large canal 38 m. long, and from 115 to 130 ft. wide. Two other similar engines were applied to the same work, and the pumping was continued from May, 1848, to July 1, 1852. Then the area was thoroughly drained. The entire expenses from the commencement of operations in 1839 to the close of 1855 were estimated at £748,445, which would be more than paid by the proceeds of the sale of the lands. The draining of the lake, however, increased a difficulty which will be appreciated by a consideration of the system of drainage in Holland. Along much of the seaboard of that country the waters of the ocean are kept from overflowing the land by immense dikes. The country is divided into several districts, called hydraulic administrations, each of which has three divisions of surface, viz.: natural lands, basins, and polders. The basins comprise the marshes, lakes, canals, and drains, having one surface level, which is below high and above low tide, and connect with the sea by sluices furnished with gates, which open when the internal waters are higher than the external, and shut when they are lower. The polders are lands which lie below the surface of the waters in the basins, and can only be kept dry by pumping. The Rynland hydraulic administration comprises 305,000 acres, which before the draining of Haarlem lake was divided into 76,000 acres of natural lands, 56,000 acres of basin, and 173,000 acres of polder lands; but since the addition of the lake to the latter, the basin covers only 11,500 acres, while the polder lands have an area of 217,500 acres. Now the basins are the reservoirs of the waters which are raised from the polders and also of the drainage from the natural lands. When the tides are regular, at every ebb they empty a portion of their contents, and thus maintain a capacity to receive the natural and artificial drainage until the next ebb; but if by the action of the winds the external waters are held at a higher level than those in the basins through the period of an ebb tide, a collection of water in the latter ensues, and may come to equal their capacity. Before this occurs, however, the pumping from the polders must cease, for some space must be allowed for the natural drainage. At about

the mean level of the tides in the Zuyder Zee there is a mark upon a pile which is called the A. P., or Amsterdam pile, and which is the point of reference for regulating the height of water in the basins. There is also a mark for each administration, called the point of arrest. This point is not at the same level for all the administrations, some being allowed to continue their pumping operations longer than others. If the water in the basins were allowed to become too high, there would be danger of the overflowing and breaking away of the dikes. It will therefore be seen that the area of the basins is an important matter. If it bears only a small proportion to that of the land to be drained, they soon become filled, and unless they can empty their contents into the sea, the drainage of the polders must cease, and consequently they will become overflowed. As the range of tide along the Dutch coast is about 6 ft., only a small range of rise and fall, or capacity, can be allowed for the basins, when their area bears so small a proportion to that of the drained lands as it does in the Rynland hydraulic administration since the drainage of Haarlem lake has so greatly reduced the basin area. One circumstance has been taken advantage of in the work of draining, which is that the S. W. winds raise the level of the waters in the N. E. portion of the basins so that they may continue to discharge their contents longer than they could if they remained level. The S. W. end of the Zuyder Zee, also, by having its water level depressed, can continue to receive the drainage from the lands longer than if the surface remained level. The wind, therefore, is utilized as a source of work or energy, which goes far to make up for the loss incurred by diminution of the area of the basins. The draining of Haarlem lake had become a matter of necessity more than of utility; for, as it lies in a peat formation of great depth, connected with other lakes, the barriers were constantly being washed away, which, by increasing the surface of the water, allowed the waves to become higher by the action of the wind; and thus the surrounding country became subject to inundation.

**DRAKE, Daniel**, an American physician, born in Plainfield, N. J., Oct. 20, 1785, died in Cincinnati, Nov. 5, 1852. His father emigrated to Mason co., Ky., in 1788, where Daniel lived until his 16th year on a small farm. In December, 1800, with very little education, he was placed under the care of Dr. William Goforth of Cincinnati as a student of medicine, and in 1804 commenced practice. In 1816 he graduated at the university of Pennsylvania, and in 1817 he lectured one session in the Transylvania medical school at Lexington, Ky. In December, 1818, on his personal application, the legislature of Ohio granted a charter for the medical college of Ohio at Cincinnati, and also established there the commercial hospital. In the autumn of 1820 the former institution was opened for students, and



for two sessions Dr. Drake was connected with it. In 1823 he again became professor in the Transylvania school, and afterward in medical colleges at Philadelphia, Louisville, and Cincinnati. As a professor of the theory and practice of medicine he held an eminent position, and as a practitioner his reputation was coextensive with the Mississippi valley. His writings were voluminous, but generally not intended for permanent use. His first considerable work was "An Historical and Scientific Account of Cincinnati" (1815). His last work, on which his fame as an author principally rests, was "A Systematic Treatise, historical, etiological, and practical, on the Principal Diseases of the Interior Valley of North America, as they appear in the Caucasian, African, Indian, and Esquimaux Varieties of its Population" (2 vols., 1850-'54). A memoir by Edward D. Mansfield was published in Cincinnati in 1855.

**DRAKE, Sir Francis**, an English navigator, born near Tavistock, Devonshire, according to some authorities in 1539, and to others in 1545 or 1546, died near Puerto Bello, Dec. 27, 1595. He received a scanty education through the liberality of a kinsman, and was apprenticed to the master of a bark, who bequeathed him his vessel. Being thus at the age of 18 years a good sailor and the proprietor of a ship, he made commercial voyages to the bay of Biscay and the coast of Guinea. He then sold his vessel and invested the proceeds with all his savings in the expedition of Capt. Hawkins to Mexico in 1567, receiving the command of the Judith. The fleet was attacked by the Spaniards at San Juan de Ulua, and only two of the six ships escaped. Drake returned to England with a loss of his entire property, and fruitlessly petitioned the court of Spain for indemnity. Enraged by his treatment, he began to sail with the avowed object of pillaging the Spaniards. In 1570 he obtained a commission from Queen Elizabeth. In 1572 he armed two ships at Plymouth, with which, joined by a third at Port Pheasant, on the coast of South America, he made a descent upon New Granada, captured and plundered various Spanish settlements, and made at the expense of his enemies a fortune vastly larger than that they had taken from him. He returned to England in 1573, and was welcomed as a hero. While at Darien he had seen from a mountain top the waves of the Pacific, and had there conceived the purpose of an expedition into those waters. Under the patronage of Elizabeth, he set sail from Plymouth, Dec. 13, 1577, with five vessels and 164 gentlemen and sailors, to follow the route which had been traced by Magellan. Drake pillaged the Spanish settlements of Peru and Chili, captured a royal galleon richly laden with plate, and took possession of California in the name of the queen of England; and then, fearing to meet the Spaniards in superior force if he returned, he sought to find a N. E. passage to the

Atlantic. Repelled by the severe cold, he determined to make the circuit of the globe. He traversed the Pacific ocean, the archipelago of the Spice islands, and the Indian ocean, doubled the cape of Good Hope, and arrived at Plymouth in November, 1580. Elizabeth received him with favor, and soon afterward knighted him and partook of a banquet on board of his ship. The rupture which followed between Elizabeth and Philip II. gave Drake a new opportunity, and within one year he captured and plundered Cartagena and several other towns, burned the forts of San Antonio and Saint Augustine, and visited and brought away the remains of the colony which Raleigh had planted in Virginia. In 1587 he was placed in command of a fleet of about 30 sail designed to attack the Spanish ports. He destroyed 100 ships in the harbor of Cadiz, and captured an immense carrack, from papers in which the English first learned the value of the East India traffic, and the mode of carrying it on. In 1588, as vice admiral, he commanded one squadron of the fleet by which, with the assistance of the elements, the "invincible armada" was annihilated. In 1589 he ravaged the coasts of the Spanish peninsula, and in 1592-'3 was a member of parliament for Plymouth. In 1594, a report having reached England that Spain was preparing a fleet more numerous and powerful than the armada, he again entered the service. Convinced that the West Indies was the point where Spain could be best attacked, he sailed for America in 1595 with 26 vessels, in company with Admiral Hawkins. A divided command produced its usual bad results, and their first attempts were inharmonious and fruitless. At Porto Rico Hawkins died, either of a wound or of chagrin, and Drake then gained new triumphs. He burned Santa Marta, Rancheria, Nombre de Dios, and Rio Hacha; but a fatal malady broke out among his sailors, and as he heard of the defeat of a division of his forces which he had sent to operate by land, he fell sick and died from the combined effects of fever and of mental agitation on account of the reverses of the expedition, and was buried at sea.

**DRAKE, Friedrich**, a German sculptor, born in Pymont, June 23, 1805. He began life as a mechanic, and struggled against poverty until at length his talent was recognized and developed by Rauch. His first work, representing a madonna, was purchased by the empress of Russia. His busts of his teacher, of Schinkel, and of the Humboldts made his reputation; and he eventually became a member and professor of the academy of Berlin. In 1836 he produced a bust for the Mōser monument at Osnabrück, and in 1844 he completed a colossal group allegorically representing the eight provinces of Prussia, for the royal palace. Among his subsequent works are two large marble statues of Frederick William III., one in Stettin (1845), and the other in the Thiergarten of Berlin (1850); Oken's bust, and the statue of the

elector John Frederick, in Jena (1858); one of Prince Malte-Putbus, in Rügen (1859); one of Melanchthon, in Wittenberg; the colossal equestrian statue of Frederick William III., in Cologne (1864); and the statue of Schinkel, in Berlin (1869).

**DRAKE, Joseph Rodman**, an American poet, born in New York, Aug. 7, 1795, died there, Sept. 21, 1820. He lost his father in early life, and with three sisters struggled against adversity. He studied medicine, and shortly after taking his degree in 1816 married a daughter of Henry Eckford, the eminent ship builder, which placed him in affluence. James Fenimore Cooper and Fitz-Greene Halleck were among his most intimate associates, and a conversation between them as to the poetical uses of American rivers, in the absence of historical associations such as belong to the streams of the old world, was the occasion of Drake's longest and most imaginative poem, "The Culprit Fay," written in August, 1816. He travelled in Europe in 1818, and during his tour addressed several witty poetical epistles to his friend Halleck. In 1819 Drake and Halleck formed a literary partnership, and contributed, under the various signatures of "Croaker," "Croaker, Jr.," and "Croaker & Co.," many effective and amusing verses to the New York "Evening Post." The "Croakers" were collected and included in an edition of Halleck's poems published in 1869. Drake's health failing, he passed the winter of 1819-'20 in New Orleans. But the progress of consumption could not be arrested, and a few months after his return to New York he died at his residence in Park row, and was buried at Hunt's Point in Westchester county. His death called forth a beautiful poetical tribute from Fitz-Greene Halleck. In 1835 a volume of Drake's poetry, including his most popular poem, "The American Flag," was published in New York by his only daughter, Mrs. Janet Halleck De Kay. No American poet, with the exception of Bryant, has attained an equally early maturity of poetic genius. Almost all of his poems, including "The Culprit Fay," were written before he was 21, while several were produced at the age of 16.

**DRAKE, Nathan**, an English physician and miscellaneous writer, born in York in 1766, died at Hadleigh, Suffolk, June 7, 1836. He was educated at the university of Edinburgh, and practised his profession in Hadleigh from 1792 till his death, during which time he was a frequent contributor to literary and medical periodicals. His works are numerous; they include "Shakespeare and his Times" (2 vols. 4to, London, 1817), and many volumes of essays, criticisms, and illustrations of the writings of the age of Queen Anne.

**DRAKE, Samuel Gardner**, an American author, born at Pittsfield, N. H., Oct. 11, 1798. He was educated at the common schools of the neighborhood, and between the ages of 20 and 27 was a district school teacher. He removed to Bos-

ton, and in 1828 established an antiquarian book store, the first of its class in the United States. In 1825 his literary and antiquarian labors commenced with the republication with notes of Church's "Entertaining History of King Philip's War," of which several editions have since appeared. In 1833 he reprinted five old tracts, which, with the preceding work, comprise in his opinion all that can be recovered in relation to King Philip's war. In 1832 appeared his "Indian Biography," and in 1833 the "Book of the Indians, or History and Biography of the Indians of North America," a work of high authority for facts, and of which the 11th edition, much enlarged, appeared in 1851. His remaining publications on Indian history are "Old Indian Chronicles" (1836), "Indian Captivities" (1839), "Tragedies of the Wilderness" (1841), "Introduction and Notes to Hubbard's Indian Wars" (2 vols., 1865), "The old Indian Chronicle" (a new series, 1867), and "History of the Five Years' French and Indian War" (1870). Among his important contributions to American history are a "Memoir of Sir Walter Raleigh" (1862), "Introduction and Notes to Mather's Relation" (1862), and "Annals of Witchcraft in the United States" (1869). Mr. Drake was one of the founders of the New England historical and genealogical society, its president in 1858, and for many years editor of its quarterly "Register." In 1858-'60 he resided in London.—His son, FRANCIS S. DRAKE, published in 1872 a "Dictionary of American Biography" (1 vol. 8vo, Boston; new ed., 1874).

**DRAMA** (Gr. *δράμα*, from *δρᾶν*, to do or act), a story represented by action. The principle of imitation is inherent in human nature; painting, sculpture, and the drama must be coeval with society, and have been practised in some form by almost every nation. Among the South sea islanders a rude kind of drama was discovered. In China the drama dates from remote ages. The war dance of the Indian and the African, intermingled with pantomimic descriptions of the preparations for battle, the stealthy advance upon the foe, the combat, and the death of the enemy, is essentially a dramatic exhibition. But that form of the drama which is accepted and followed in Europe, divided chiefly into tragedy and comedy, was the creation of the ancient Greeks. The religious festivals of Bacchus were believed to have been introduced into Greece by Melampus. In the Bacchic ritual an ode in honor of the god was recited; and to produce the best ode, which should be selected by the priests to be inserted into their ceremony, became a favorite contest among the poets. A goat was either the principal sacrifice at the altar, or the prize awarded to the successful competitor; thus from the two words *τράγος*, goat, and *ᾠδή*, song, came the Greek *τραγῳδία*, tragedy (literally, goat song). In like manner, at the rustic festivals or harvest homes of the Greeks, semi-religious ceremonies, composed of odes

and dances in honor of Bacchus, were enacted. These odes, being more genial and comic, were called *κωμῳδία*, comedy, from *κῶμη*, village, and *ὄδῃ* (literally, the song of the village).—The earliest known form of drama is the dithyrambus, a hymn in honor of Bacchus, song by a chorus accompanied by music, gesture, and dances. About 570 B. C. Susarion, a native of Megara, recited an ode at Athens. In 535 Thespis, a native of Icaria, recited an ode, with responses by a dithyrambic chorus; in this we perceive the first germ of dialogue. Such were the rude elements found by Æschylus about 500, and out of them he created the drama as we now behold it. Nothing essential has since been added to its structure. He removed the chorus into the background, and used them only as an auxiliary. He brought a second actor upon the scene, and introduced dialogue; thus the drama became an action instead of a narrative. He invented scenery, costume, and machinery. Banishing the lewd and Bacchanalian character from the dithyrambic hymn, he supplied its place with pure tragedy. From his works were gathered those rules called the unities, referred to by Aristotle. These changes were wrought within 30 years. His expansion of the drama caused the Athenians to build the great theatre of Bacchus, the Lenæum, the former theatre having broken down under the pressure of the people gathered to witness a representation in which Æschylus and Pratinas were rivals. Thirty years later Sophocles introduced a third actor, and thus diffused the dialogue and fertilized the action. As a dramatic poet he surpassed Æschylus by a noble grace and a sweet majesty. Fifteen years afterward Euripides enabled Greece to behold as contemporaries the three greatest purely tragic poets the world has produced. In reviewing their works we must remember that Æschylus was the creator of that fanciful world which Sophocles and Euripides cultivated. The dramas of Æschylus are dark, gloomy, and terrible; thunder and lightning are their atmosphere, and demigods their *dramatis personæ*; his human beings are gigantic in moral stature, and removed above our sympathies. Sophocles drew human nature as it ought to be. Euripides depicted men and women as they were. The origin of the drama is popularly but erroneously ascribed to Thespis. This improvisatore did no more than improve upon the dithyrambus; he first organized a regular chorus, and invented dances of peculiar energy and grace; but his performances were a kind of ballet farce. The tragedy of the Greeks was a fable or a series of events begotten of each other in a natural sequence. It began with a simple position, so selected that the auditor required no explanation to understand the present condition of affairs. The development of the characters was required to be simultaneous with the action, the one being involved in the other. The action should not stray from the one place

beyond such a limit as the time employed in the performance might naturally permit; nor should a lapse of time take place during the piece longer than one day. These unities of action, place, and time, however, so strenuously insisted upon by the French dramatists, were not always strictly observed by the Greeks. Aristotle refers indistinctly to the unity of action; he says in reference to the unity of time: "Tragedy endeavors as much as possible to restrict itself to a single revolution of the sun." Of the unity of place he says nothing. The Greek tragedy was often composed in trilogies, or three distinct plays, all connected; such, for example, was the trilogy of Æschylus, formed of the "Agamemnon," the "Choëphori," and the "Eumenides." In the first, Agamemnon, returning from the siege of Troy, is murdered by his wife Clytemnestra; in the second, Orestes, Agamemnon's son, avenges his father by the slaughter of his mother; in the third, Orestes is pursued by the Furies for this unnatural deed; the gods cannot agree upon his case until Minerva decides in his favor, and releases him from the torture of the avenging divinities. These three conjoined formed a complete action. The early history of comedy is more obscure than that of tragedy. The earliest comic poet of whom we have remains is Aristophanes, who flourished nearly a century after Æschylus. He was the last of what was called the old school. Comedy was divided into three forms, the old, the middle, and the new. In the first or old comedy, the characters were real living personages, who were freely satirized under their real names. This license was soon so abused that a law was passed forbidding the names of real personages to be used in comedy. This impediment produced the second or middle comedy, where the prohibition was evaded by giving fictitious names to the real characters, and distinguishing the individual intended to be satirized by a mask or by some unmistakable inference. The middle comedy lasted about 50 years, when it was superseded by the third or new comedy; in this form the characters and the subject were fictitious, and as the old satirized and ridiculed statesmen, orators, and generals under their real names, so the new was aimed at abstract vice, and not at the individual offender. As tragedy descended from the contemplation of divine matters to depict human woes, it gradually lost its grandeur. So, also, as comedy divested itself of its direct influence upon men and things, and from a statesman became a philosopher, it lost its pith and power. The list of dithyrambic poets preceding Æschylus, from 700 to 525 B. C., includes Archilochus, Simonides, Lasus, Arion, Stesichorus, Solon, Susarion, Hipponax, Theognis, Thespis (birth of Æschylus). Afterward came Chærius, Phrynichus, Epicharmus, Æschylus (invents the drama, and first exhibits in 499), Chionides, Sophocles (first victory in 468), Euripides (first exhibits in 455), Cratinus,

Aristarchus, Ion, Crates, Achæus, Melanippides, Pherecrates, Phrynichus the comic poet, Lysippus, Eupolis, Aristophanes (427), Agathon, Xenocles, Amipsias, Sannyrion, Astydamos, Antiphanes, Theopompus, Eubulus, Alexis, Heraclides, and Menander (first exhibits in 321), after whom the Greek drama died obscurely. The Romans derived their drama from the Greeks. Terence, Plautus, and Seneca are the only Latin dramatists worthy of mention, and these are but translators and imitators of the Greek. The only element introduced by the Romans into the drama was farce, an invention of the Tuscans; buffoonery became more popular than wit. In truth the Roman people took little pleasure in pure intellectual amusement; they preferred to watch the agonies of the body suffered in the circus, rather than sympathize with the woes of the soul simulated in the theatre.—Thus ended the first or classic age of the drama. The second, or romantic age, gave its first indication of existence in the 12th century, when dramatic performances called *entremets* were introduced, as the word implies, between the services at royal banquets and carousals. These *entremets* soon became pageants, masks, and mummeries, and lasted as distinct dramatic entertainments up to the period of Shakespeare. Simultaneously a dramatic composition called a mystery, usually founded on passages of Scripture, was introduced and became a popular exhibition on saints' days. Subjects from the Bible, rudely treated in the form of a dialogue between the holy personages, were represented on a stage erected in the church or church yard, the priests and acolytes being the actors. These performances were carried to an abuse, and became so blasphemous that they were suppressed. The next form of drama was the morality, bearing a relation to the mystery similar to that between the new and old comedy of the Greeks. The morality was aimed at abstract vice, its action was a fable, its characters were typical. In the 15th and 16th centuries histories began to be written—long, rambling pieces of action without form or object, but introducing rudely the design of that romantic drama destined to so wondrous a perfection under the hands of Shakespeare and his colleagues. As the classic drama was derived from the dithyramb, a pure poetic germ, subsequently developed into action, the romantic drama was derived from the pageant, mask, or mummer, a pantomimic germ, subsequently developed into poetry. In the first the action is subservient to the passion; in the second the passion is subservient to the action. In the Elizabethan age the romantic drama sprang at once into existence; and as in the single life of Æschylus the classical or Greek drama passed from infancy to maturity, so Shakespeare and his colleagues raised the romantic or Gothic drama from rudeness to the highest perfection it has ever achieved. In the roman-

tic drama the unities of time, place, and action are not observed. The poet is allowed unbridled license; prose and poetry may be mingled without rule or reason, beyond the aptitude of each to the moment and the character. The English dramatists of this age gave originality at least to the form of the romantic drama, and, whatever its faults, it was new. The French and Italian poets clung to the Greek models; Corneille and Racine were imitators of Sophocles and Euripides; Alfieri affected the same ancient simplicity. As students of the Greek, their individual merit is great; but having had no share in the progress of the drama, they have no prominent place in its history. The Italians and Spaniards at this period contrived a species of performance, part pantomime, part farce, part comedy of intrigue. It was derived from those Italian narrators of whom Boccaccio is the best type, and represented dramatically short and pithy tales. Lope de Vega was the first to inaugurate this comedy of intrigue, and Calderon surpassed him in it; it was quickly imitated and greatly improved by the French, who by admitting more Italian elements gave it variety and scope. Hardy, Rotrou, and Corneille, Scarron and Quinault, prepared the public taste for Molière, who truly founded and made the second or middle age of comedy, as Shakespeare and his colleagues made the first or old. Comedy at this time mainly occupied the stage. In England the four great masters, Wycherly, Congreve, Vanbrugh, and Farquhar, brought forth the prose drama. In the beginning of the 18th century the sentimental drama, a mixture of comedy and tragedy, was introduced, but cannot be considered a forward movement in the art. In Germany it obtained great popularity under Kotzebue, and at the same time a wild and ideal, often mythic and philosophical form of dramatic poetry was created by Schiller and Goethe. These poets rather embellished dramatic literature than added to the development or progress of the drama as an art. Lessing, their predecessor, may be said to have founded the German drama, but he attempted no reform.—The next and last great step which the drama has made, and one that has become prominent in the present age, is the invention of opera, or a drama in which music takes the place of poetry, and the dramatic action is subservient to a new musical development. It is a mistake to presume that an opera is a musical drama. The musical form of an opera and its dramatic treatment are essentially different from the form and treatment of a drama based on the same fable. There is also in the form of the music, apart from the libretto, a plan and proportion to which the drama must be subservient.—Among the various minor forms of the modern drama are melodrama, farce, vaudeville, and pantomime. Melodrama owes its invention to the laws which restricted the performance of tragedies and comedies to certain privileged theatres. Booths were erect-

ed in which serious pantomimes, or dramas without words, were performed, accompanied throughout with expressive music. By degrees the actors ventured a few extempore phrases or jests. This license was gradually extended, until dialogue was regularly introduced, and the music was only used to accompany the movement of the actors. Melodrama is now understood to be a drama wherein the passion and development of character are subservient to the action and plot; whereas tragedy is a drama where the action and plot are subservient to the passion and development of character. Farce is a humorous piece of buffoonery, in which probability may be outraged both in the incidents and character, and stands in relation to comedy as melodrama does to tragedy. Vaudeville is an invention of the French stage. It has its name from *vau de Vire*, which was originally a satirical song containing a keen, witty thought, and applicable to some popular person or event. It was a lyric epigram invented in that part of Normandy called Val or Vau de Vire, and carried thence to Paris, where these musical satires became the vogue. Presently the writers of small comedies threw their keenest epigrams into verses which might be sung to any air that would happily suit them, and were called vaudevilles. The comic pieces through which they were scattered eventually received the name. When the work is but slightly speckled with these musical epigrams, it is distinguished as a *comédie vaudeville* or a *drame vaudeville*. Pantomime is a drama without language, composed of gesture accompanied with music. It is probably the most ancient form of drama, and has changed less in its essential character than any other. The most perfect and most elegant kind of pantomime is the ballet, where graceful dances are interspersed.—Further accounts of the dramatic literature of the principal nations will be found under the titles of the respective countries.

**DRAMBURG**, a town of Prussia, in the province of Pomerania, 53 m. E. by N. of Stettin; pop. in 1871, 5,473. It has a Protestant gymnasium, a normal school, and several woollen factories, tanneries, and distilleries.

**DRAMMEN**, a commercial town of Norway, on the S. coast, in the province and 20 m. S. W. of the city of Christiania; pop. in 1866, 13,032. It lies on both sides of the river Drammen, and is composed of three small villages, separated by channels of the river. The commerce of which Drammen is the centre gives it the third rank among the cities of Norway, and in respect to its timber trade it stands first. It manufactures tobacco, earthenware, sail cloth, rope, carriages, leather, &c.; and besides exporting timber, has a commerce in iron ware and agricultural produce. About 40,000 tons of shipping are annually employed in its port. It suffered considerably in 1850 and 1857 from conflagrations.

**DRANESVILLE**, a village of Halifax co., Virginia, 20 m. W. by N. of Washington, where a

battle was fought Dec. 20, 1861, by a brigade of the Union army of the Potomac under Gen. Ord, and a confederate detachment under Gen. Stuart. The engagement was mainly an artillery duel, in which, the Union guns being better served, the confederates suffered most, and withdrew. The Union loss was 69 killed and wounded; that of the confederates more than twice as many. This skirmish was the first success gained by the army of the Potomac, and called forth a special congratulatory letter from the secretary of war.

**DRAPER**. I. **John William**, an American chemist and physiologist, born at St. Helens, near Liverpool, England, May 5, 1811. He received his early education in the Wesleyan Methodist school at Woodhouse Grove, and was then placed under private instructors, devoting much attention to chemistry and natural philosophy. The higher mathematics were also a part of his early training. He subsequently went to the university of London, where he prosecuted his chemical studies. Some of his ancestors had been attracted to America before the revolution, a greater part of his family connections followed, and in 1833 he joined them. He continued his chemical and medical studies at the university of Pennsylvania, where he took the degree of M. D. in 1836, with the rare distinction that his thesis was selected for publication by the medical faculty. A few weeks later he was appointed professor of chemistry, natural philosophy, and physiology in Hampden-Sidney college, Virginia. During his residence there his time was occupied in chemical and physiological investigations, many of the latter appearing in the "American Journal of Medical Sciences." In 1839 he was called to the chair of chemistry and natural history in the academic department of the university of the city of New York, where, besides instruction in those branches, he delivered lectures to the advanced undergraduates on physiology. In 1841 he was appointed professor of chemistry in the university medical college, and in 1850 physiology was added to the chair of chemistry. He is now (1874) president both of the scientific and the medical department of the university. Although his researches have been mostly experimental, involving great labor and cost, he has written voluminously and with high reputation. Besides contributions to various other scientific journals, he furnished to the "London and Edinburgh Philosophical Journal" and to the "American Journal of Science and Arts" between 1837 and 1857 about 40 memoirs, principally on topics previously little understood. For an account of some of these investigations, see **ACTINISM**, **ACTINOMETER**, and **PHOTOGRAPHY**. He is the author of many literary works, reviews, &c., the latter for the most part published anonymously; of a "Treatise on the Forces which produce the Organization of Plants" (4to, New York, 1844); of a popular "Text Book on Chem-

istry" (12mo, 1846), and another on "Natural Philosophy" (8vo, 1847), which consist of excerpts from his courses of lectures; and of a treatise on "Human Physiology, Statical and Dynamical, or the Conditions and Course of the Life of Man" (8vo, 1856), many editions of which have been published. His "History of the Intellectual Development of Europe" appeared in 1862, and shortly afterward in England. It has been translated into French, German, Italian, Polish, Russian, &c. In 1865 four lectures that he had given before the New York historical society were collected in a volume under the title of "Thoughts on the future Civil Policy of America;" and between 1867 and 1870 appeared in three volumes his "History of the American Civil War." In the preparation of this work he enjoyed singular advantages from the friendship and assistance of officers, both civil and military, who had taken a conspicuous part in the events. This work too has been largely translated. To him is due the discovery of many fundamental facts of spectrum analysis; and among his latest papers are "Experimental Examinations of the Distribution of Heat and of Chemical Force in the Spectrum." **II. John Christopher**, son of the preceding, born in Prince Edward co., Va., March 31, 1835. He graduated in the medical department of the university of the city of New York in 1857, and from 1858 to 1860 was professor of physiology in the same institution. For three years he was professor of chemistry in the Cooper union, and he is now (1874) professor of chemistry in the university medical college, and professor of physiology and natural history in the college of the city of New York. He has published a treatise "On Respiration" (8vo, New York, 1856), and a "Text Book on Anatomy, Physiology, and Hygiene" (8vo, 1856); and has contributed freely to English and American medical and scientific journals. **III. Henry**, brother of the preceding, born in Prince Edward co., Va., March 7, 1837. He graduated in the medical department of the university of the city of New York in 1858, and since 1860 has been professor of physiology there, and is also professor of physiology and analytical chemistry in the scientific department. He has made, at Hastings on the Hudson, the largest telescope (28 inches aperture) in the United States, and has devoted much attention to photographic and spectroscopic examination of the moon and other heavenly bodies. He has published a memoir "On the Construction of a Silvered Glass Telescope" (4to, Smithsonian institution, 1864), and "Text Book of Chemistry" (12mo, New York, 1864); and has been a frequent contributor to scientific periodicals.

**DRAPER, Sir William**, an English military officer, born in Bristol in 1721, died in Bath, Jan. 8, 1787. He was educated at Eton and Cambridge, entered the army, won distinction in the East Indies, obtained a colonelcy in 1760, acted as brigadier at the capture of Belle Isle

in 1761, and led the land forces at the taking of Manila in 1762. When the first of the "Junius" letters appeared in January, 1769, he came forward under his own name in defence of his friend the marquis of Granby. Junius replied with marvellous skill and sharpness; two more letters passed on each side, and Sir William then retired from the contest. Six months afterward, when he saw these letters republished, he appeared twice again in print to complain of their injustice, and was again worsted by his anonymous antagonist. During the same year he visited America, where he married Miss De Lancey of New York. In 1779 he was appointed lieutenant governor of Minorca, and on the surrender of that island brought 29 charges against the governor, Murray, for all but two of which he was obliged to offer an apology.

**DRAUGHTS**, a game played by two persons, on a checkered board like the chess board, with 12 or 20 pieces on each side, which capture each other by angular movements governed by certain rules, until the game ends by one player losing all his pieces, or by both players getting their pieces into positions from which they cannot be moved. In America the game is commonly called checkers. In France it is known as *le jeu de dames*, in Italy as *dama*, in Germany as *Damen*. It has been played in Egypt for more than 4,000 years, the Egyptian-Arabic name being *dameh*, and made its appearance in Europe only three or four centuries ago, when there was much intercourse between southern Europe and Egyptian ports. In Polish, the game has, besides that of *dama*, the name of *arcaby* or *warcabny*, supposed to be equally of oriental origin. In Spanish, the word *ajedrez*, applied to both chess and draughts, is also of eastern derivation, and appears to be nearly equivalent to the American term checkers.—The origin of the game is uncertain. It is supposed to have preceded chess, and it is certain that in Egypt, as appears from the monumental paintings, it was common under the earlier Pharaohs. It was played as now with pieces, all of which on the same board were alike in size and form, though on different boards they varied, some being small, others large and rounded at the top or carved into human heads. The kind used by King Rameses II., about 1300 B. C., who is represented on the walls of his palace at Thebes playing at draughts with the ladies of his household, resembled small ninepins, and seem to have been about  $1\frac{1}{4}$  inch high, on a circular base half an inch in diameter. Some have been found of ivory,  $1\frac{1}{4}$  inch high and  $1\frac{1}{4}$  in. diameter, with a small knob at the top. The opposite sets of pieces were distinguished sometimes by their color and sometimes by their form, one set being black, the other white or red, or one set having round, the other flat tops. It is uncertain how the Egyptians played the game, though from the position of some of the pieces in the paintings it seems that they did not take back-

ward, as is done in the Polish game. The modern Egyptians, who use pieces similar to those used by their predecessors, play the game as it is generally played in Europe and America. By the Greeks the invention of draughts, as well as of dice and many other things, was poetically ascribed to Palamedes, one of the heroes of the expedition against Troy.—In playing draughts, the board is placed with a double corner on the right hand of each player. Each player places his pieces on the three lines of squares nearest to him. In England the white squares are played upon; in Scotland and America the black squares are generally selected. The game is begun by each player moving alternately one of his men along the diagonal on which they are first placed, one square at a time to the right or the left. When two hostile pieces encounter each other, the one that has the move may take the other, if there be a vacant square of the color played upon behind it, by leaping over the other into that square. The piece leaped over is removed from the board. If several pieces should be exposed by having alternate open squares behind them, they may all be taken at once, and the taking piece placed on the square behind the last piece captured. When a piece has reached one of the four squares of the extreme opposite row, it becomes a king, and is crowned by placing one of the captured pieces upon it, or, as the men are now sometimes made, by turning it over and exposing a crown represented on the other side. Kings can move backward as well as forward, though only one square at a time. The principal laws of the game are these: If a piece is touched, it must be moved, if a move be possible; the player who has the move must take a piece which is exposed to capture; if he neglects to take it, his adversary may remove from the board the piece with which the capture should have been made; but a player has no right to decline to take under any circumstances. The first move of each game is to be taken by the players in turn; if lots are drawn for the move, he who gains the choice may move first or require his adversary to move. In Polish draughts, a variety of the game played not only in Poland, but in other parts of the continent of Europe, and sometimes in England and America, the pieces are moved forward as in the English form of the game, but in taking they move like the kings of the English game, either backward or forward. The kings in the Polish game have the privilege of passing over several squares at one time, and even over the whole length of the diagonal when no pieces obstruct the move. Polish draughts is sometimes played with 40 pieces on a board divided into 100 squares.—M. Mallet, a professor of mathematics, published a treatise on draughts at Paris in 1668. Another teacher of mathematics, William Paine, published at London in 1756 an "Introduction to the Game of Draughts." The best work on the subject is

the "Guide to the Game of Draughts," by Joshua Sturges (London, 1800), of which an improved edition appeared in 1835, the whole of which, with additions, is comprised in the "Handbook of Games" which forms one of the volumes of "Bohn's Scientific Library" (London, 1850).

**DRAVE** (Ger. *Drau*; Hung. *Dráva*; anc. *Dravus*), a river of Austria, one of the principal tributaries of the Danube, rises from two sources in the E. portion of the Tyrol. In its upper part it is small and extremely rapid, with craggy and overhanging banks, but it becomes navigable at Villach, and flows E. and S. E. with a slow current through a low and marshy country, through Carinthia and Styria, then along the S. border of Hungary, which it separates from Croatia and Slavonia, till it enters the Danube E. of Eszék, as a large and powerful stream, after a course of 360 m. Its navigation above Völkermarkt is obstructed by various falls and cataracts. The most important of its numerous affluents is the Mur, the largest river in Styria. Lienz in Tyrol, Villach, Marburg, Pettau, Warasdin, and Eszék are among the chief towns on its banks. Fish are plentiful in its waters, and some gold is washed from its sands. The valleys along its course are remarkable for their fertility. The Hungarian peasants descend this river on rafts of empty barrels after having disposed of their wine in the mountains of Carinthia.

**DRAVIDAS.** See ETYMOLOGY, p. 758.

**DRAWING**, the representation or delineation of objects, either as they appear to the eye, or as projected on assumed planes, or as designated by conventional signs having a certain similarity to the appearance of the objects themselves. The painter, with free hand, draws or sketches objects in their visible and natural forms; the mechanical or architectural draughtsman projects, according to certain established rules and principles, objects existing or designed; while from the notes of the surveyor the topographical draughtsman plots the surface of a field or locality, with its natural and artificial objects represented somewhat as they would appear projected on a transparent plane above them, but with certain conventionalities to express more definitely certain features. Architectural and mechanical drawing is in general the delineation of objects by geometric or orthographic projection. Since the surfaces of all bodies may be considered to be composed of points, the first step is to represent the position of a point in space, by referring it to planes whose position is established. In general these planes are assumed at right angles to each other (fig. 1), and the points projected upon them make up the drawings of the plan, end and side elevation. Let a brick be held flatwise in the corner of a rectangular box, with its sides parallel to the various sides of the box; if now from the several corners of the brick perpendiculars be let fall upon the adjacent sides, the points thus

found will be the orthographic projections of the corners; and if these points be connected by corresponding lines, there will be outlines of the brick under three views or projections: on the bottom of the box, a rectangle 8 by 4 in., being the plan of the brick; on one side, a

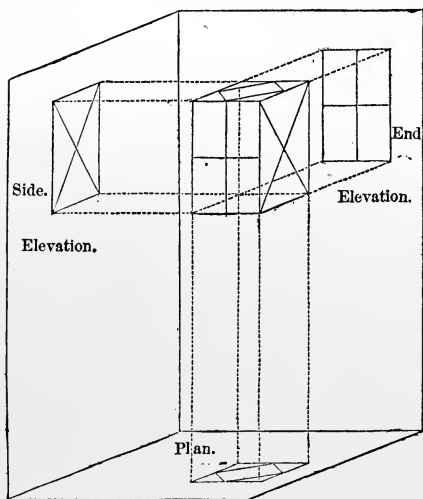

FIG. 1.

rectangle 8 by  $2\frac{1}{2}$  in., the side elevation; on the other side, a rectangle 4 by  $2\frac{1}{2}$  in., the end elevation. If the brick be inclined to either or all of the sides of the box, the projected outlines will be varied; but the same rule for determining the position of points obtains, viz.: by letting fall perpendiculars on the planes to which they are referred. The orthographic projection of any object in outline is the shadow it would cast on a plane perpendicular to the rays of the sun, if held between it and the sun. Simple objects in general may be defined by two views, a plan and elevation; but often, to illustrate the construction of the interior, sections are necessary, that is, the appearances that might be presented were the objects cut by planes; all portions that would be thus absolutely cut are designated by filling up the outline with a quantity of inclined parallel straight lines, at equal intervals from each other; should there be distinct parts in section, in contact with each other, to prevent confusion the different sections are expressed by lines inclined in opposite directions. In most architectural and mechanical constructions it would be obviously impossible that they could be drawn full size. Scales are therefore made use of in which fractional parts represent wholes. The scale in most common use in architectural drawings is that of one fourth of an inch to the foot, or  $\frac{1}{4}$  of the lineal dimensions; in mechanical drawings, one fourth or one eighth full size, that is, as usually understood, one fourth or one eighth of the lineal dimensions. Working drawings of machines,

or those intended to be used in construction, are generally laid off to as large a scale as possible; they are mostly outline drawings, consisting of lines to indicate the form of the object represented. The roundness, fullness, or obliquity of the individual surfaces is not indicated by the lines, although it may be generally inferred from the relation of the different views of the same part. The direct significance of an outline drawing is often considerably increased by strengthening those lines which indicate the contours of surfaces resting in the shadow. That all parts may be shade-lined according to one uniform rule, the light is supposed to fall upon the object obliquely at an angle of  $45^\circ$  (that the horizontal and vertical lines may be relieved equally), and in general (fig. 2) to fall from the upper left-hand corner of the paper diagonally; and the same rule is followed in the more finished drawings where both shade and shadow are introduced. As a means of avoiding the indefiniteness presented by mere outline, recourse is frequently had to the shading of the parts of a machine or edifice, which is usually done with color and a brush. In architectural drawings, a complete picture is often attempted with all the appliances of shade and shadow, intended to show the artistic effect of the construction. Color is introduced in both mechanical and architectural drawings, to show the material of which the construction is composed; and it is usual to imitate somewhat the

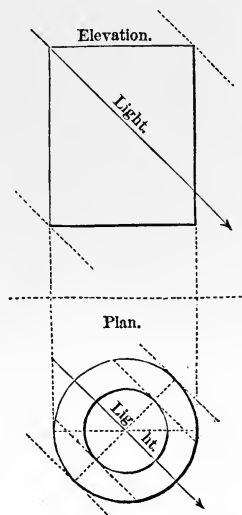

FIG. 2.

natural color of the substances.—Besides orthographic projection, architects, for the representation both of exterior and interior of edifices, often make use of perspective; and mechanical draughtsmen, for the better understanding of the parts of a machine than by separate plans and elevations, unite them by the rules of isometrical drawing. The science of perspective is the representation by geometrical rules, on a plane surface, of objects as they appear to the eye from an assumed point of view. All the points of the surface of a body are visible by means of luminous rays proceeding from these points to the eye, forming a cone of rays. The intersection of these rays by an intervening transparent plane is the perspective projection of these points, the rules for the projection of which mechani-



cally are simple and well established. The supposed transparent plane is called the plane of projection or plane of the picture. The horizon of the picture is the horizontal line resulting from the intersection of the plane of the picture by a horizontal plane passing through

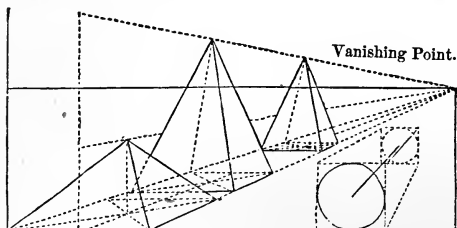

FIG. 3.

the eye. Point of view or point of sight is the point where the eye is supposed to be placed. Vanishing points are points in a picture to which all lines converge that in the object are parallel to each other. An object is said to be in parallel perspective when one of its sides is parallel to the plane of the picture (fig. 3); in angular perspective when none of its sides are so. Isometrical drawing implies that the measures of the representations of the lines forming the sides of each face are equal. The principle of isometrical projection consists in selecting for the plane of the projection one equally inclined to three principal axes at right angles to each other, so that all straight lines coincident or parallel to these axes are drawn in projection to the same scale. To draw a cube in isometrical projection (fig. 4), with a radius equal to one side of the cube, describe a circle, inscribe

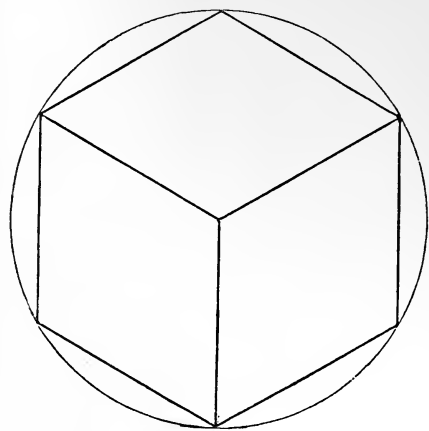

FIG. 4.

a regular hexagon, and draw lines from alternate angles to the centre; the hexagon will be divided into three parallelograms, each of which will represent a face of the cube; all the lines will be equal, and equal to the side of the cube. On these lines can be set off dis-

tances as in orthographic projection, but only upon these lines, or those parallel thereto. Curved or inclined lines are therefore to be established by reference to these lines, and not by direct measure of the lines themselves. Isometrical drawing is especially valuable to the mechanical draughtsman, as it embraces the applicability of a scale with pictorial representation. In drawings for the patent office it is of very general application.—Topographical drawing is the delineation of the surface of a locality (fig. 5), with the natural and artificial objects, as houses, roads, rivers, hills, &c., upon it, in their relative dimensions and positions; giving in miniature a copy of the field, farm, district, &c., as it would be seen by the eye moving over it. Many of the objects thus to be represented can be defined by regular and mathematical lines, but many other objects, from their irregularity of outline and their insignificance in extent, would be very difficult to distinguish. Certain signs have therefore been adopted into general use among draughtsmen, some of which resemble in some degree the objects for which they stand, while others are purely conventional. Sand is represented by fine dots, gravel by coarser dots; meadow or grass land is represented by tufts of little perpendicular lines; trees, although not consonant with the other parts of the plan, are represented often in elevation, at other times by clumps of foliage in plan, sometimes distinctive in their foliage; dwellings and edifices usually in plan, made distinctive by some small prefix, as a pair of scales for a court house, a sign post for a tavern, a horse shoe for a smithy, a church with a cross or steeple, &c. The localities of mines are represented by the signs of the planets which were anciently associated with various metals, and a black circle or dot for coal. Hills are represented by two methods, the vertical and the horizontal. In the first the strokes of the pen follow the course the water would take in running down the slopes, the strokes being made heavier the steeper the inclination; and systems have been proposed and used by which the inclination is defined by the comparative thickness of the line and the intervening spaces. In the system proposed for the United States coast survey, slopes of  $75^\circ$  are represented by a proportion of black to white of 9 to 2, and so down by nine grades to a slope of  $2\frac{1}{2}^\circ$ , in which the proportion is 1 black to 10 white. By the horizontal method, or by contours, hills are represented by horizontal lines traced round them, such as would be shown on the ground by water rising by equal vertical stages. The choice of a scale for a plot depends in a great measure on the purpose for which the plan is intended. Plans of house lots are usually named as being so many feet to the inch, plots of surveys so many chains to the inch, maps or surveys of states so many miles to the inch, and maps of railway surveys as so many feet to the inch, or so many inches to the mile. In the coast survey all the scales are expressed frac-

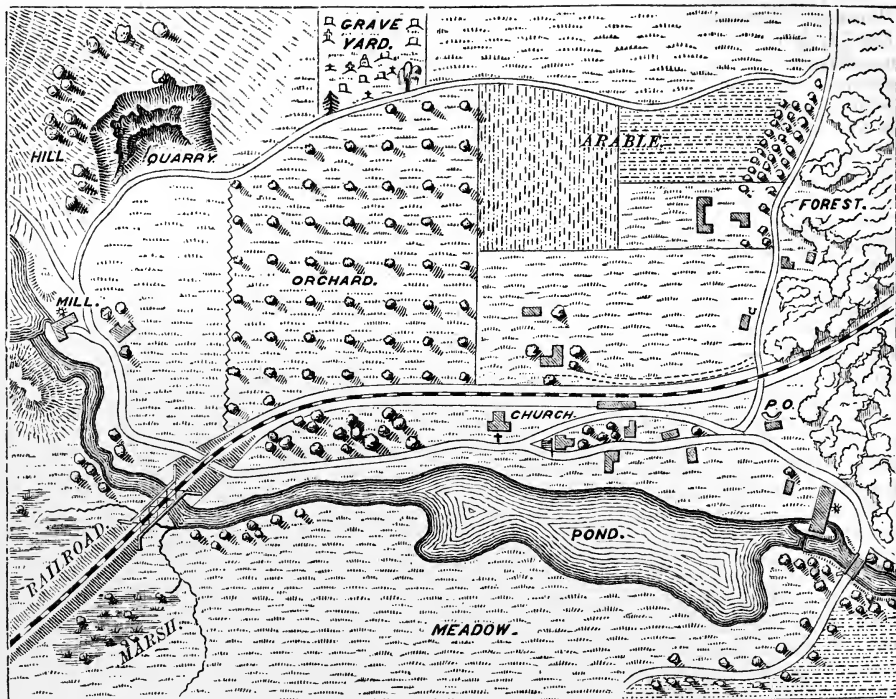

FIG. 5.

tionally and decimally. The scales of small harbor charts vary from 1 : 5,000 to 1 : 60,000; that of charts of bays and sounds is usually 1 to 80,000, of general coast charts 1 to 400,000. In the United States engineer service the following scales are prescribed: general plans of building, 1 : 120; maps of ground with horizontal curves, 1 : 600; topographical maps comprising  $1\frac{1}{2}$  mile square, 1 m. to 2 ft., or 1 : 2,640; 3 miles square, 1 : 5,280; between 4 and 8 miles, 1 : 10,560; 9 miles square, 1 : 15,840; not exceeding 24 miles square, 1 : 31,680; 50 miles square, 1 : 63,360; 100 miles square, 1 : 126,720; surveys of roads and canals, 1 : 600. In the plotting of sections, as of railway cuttings, a horizontal or base line is drawn, on which are laid off the stations or distances at which levels have been taken; at these points perpendiculars or ordinates are erected, and upon them are marked the heights of ground above base, and the marks are joined by straight lines. To express rock in a cut, it is generally represented by parallel inclined lines; rivers by horizontal lines, or better colored in blue; the depth of sounding in a mud bottom by a mass of dots. Since it would be in general impossible to express the variations of the surface of the ground in the same scale as that adopted for the plan, it is usual to make the vertical scale larger than that of the horizontal lines in the proportion of 10 or 20 to 1.—Topographical features are represented as effectively by the brush and water colors as by the pen. Colors

are used conventionally. Thus, in the practice of the French military engineers, woods are represented by yellow gamboge with a very little indigo; grass land green, gamboge and indigo; cultivated land brown, lake, gamboge, and a little India ink or burnt sienna, adjoining fields being slightly varied in tint; gardens, by patches of green and brown; uncultivated land, marbled green and light brown; brush, brambles, &c., marbled green and yellow; vineyards, purple; sands, a light brown; lakes and rivers, a light blue; seas, a dark blue, with a little yellow added; roads, brown; hills, greenish brown. In addition to the conventional colors, a sort of imitation of the conventional signs already explained is introduced with the brush, and shadows are almost invariably introduced. Topographical drawings receive the light, the same as architectural and mechanical drawings, from the upper left-hand corner. Hills are shaded, not as they would appear in nature, but on the conventional system of making the slopes darker in proportion to their steepness, the summit of the highest ranges being left white. Topographical drawings embrace but a small portion of surface, and are therefore plotted directly from measures; but in geographical maps, embracing at times a great extent of country, various projections are made use of to express as nearly as possible a spherical surface upon a plane. These species of projection are generally included under the head of mapping.

**DRAYTON, Michael**, an English poet, born in Hartshill, Warwickshire, in 1563, died in 1631. His life is involved in obscurity, and various unauthentic accounts of him are given. He is supposed to have studied at Cambridge. In 1626 he was poet laureate. He found patrons in Sir Walter Aston and the earl of Dorset, but he never became wealthy or powerful, though respected for his virtues and talent. It is not easy to discover the order of his various poems, some of which were published without date. The best known is his "Polyolbion," a descriptive poem on England, her legends, antiquities, and productions, the first 18 books of which were published in 1613, and the whole 30 in 1622. Among his other works are "The Harmony of the Church, containing the spiritual Songs and holy Hymns of godly Men, Patriarchs, and Prophets" (4to, 1591, only one copy of which edition is known to exist; and 8vo, London, 1843, edited by Dyce); "Idea, the Shepherd's Garland, and Rowland's Sacrifice to the Nine Muses" (4to, 1593), the second of which was reissued under the title of "Pastorals;" "Mortimeriados" (4to, 1596), reprinted under the title of "The Barons' Wars;" "England's Heroical Epistles" (8vo, 1598); "The Legend of Great Cromwell" (4to, 1607); "Battle of Agincourt" (folio, 1627); "The Muses' Elysium" (4to, 1630); numerous legends, sonnets, &c., mostly printed in collections; and "Nymphidia, the Court of Fairy," edited by Sir E. Brydges (Kent, 1814). The last is one of his most admirable productions. His historical poems are dignified, full of fine descriptions, and rich in true poetic spirit, and his "Poly-olbion" is moreover so accurate as to be quoted as authority by antiquaries. Notes to the first portion of it were written by Selden. He was buried in Westminster abbey, where a monument was erected to his memory. An edition of his works, with a historical essay on his life and writings, was published in 1752-'3 (4 vols. 8vo, London).

**DRAYTON, William Henry**, an American statesman, born at Drayton hall, on Ashley river, S. C., in September, 1742, died in Philadelphia in September, 1779. He was educated in England at Westminster school, and at Balliol college, Oxford. Returning to America in 1764, he became an active writer on political affairs, on the side of the government. In 1771, after revisiting England, he was appointed privy councillor for the province of South Carolina; but as the revolutionary crisis approached he espoused the popular cause. In 1774 he was appointed judge of the province, and when the continental congress was about to sit he published a pamphlet under the signature of "A Freeman," which substantially marked out the line of conduct pursued by that body. Suspended from his offices under the crown, he was made a member of the popular committee of safety, and was prominent in advising the seizure of the provincial arsenals and British mails. In 1775 he was president of the pro-

vincial congress, and in 1776 was elected chief justice of South Carolina. He soon after delivered a charge to the grand jury on the question of independence, which was published throughout the colonies and had great influence. He had produced several other political charges and pamphlets, when in 1778 he was elected a delegate to the continental congress, of which he was a prominent member till his death. He left a minute narrative of the preliminary and current events of the revolution, which was prepared for the press and published by his son, Gov. John Drayton (2 vols. 8vo, Charleston, 1821).

**DREAM**, the thoughts or series of thoughts which occupy the mind during sleep. Locke expresses the opinion that we do not always think when we sleep; but most modern philosophers, following Plato and the Platonists, are agreed that the mind is never dormant, but that consciousness continues uninterruptedly during sleep. Leibnitz rejects Locke's position, and Kant maintains that we always dream when asleep; that to cease to dream would be to cease to live, and that those who fancy they have not dreamed have only forgotten their dream. Sir William Hamilton argues that the mind is never wholly inactive, and that we are never entirely unconscious of its activity. He quotes from Jouffroy as follows: "I have never well understood those who admit that in sleep the mind is dormant. When we dream, we are assuredly asleep, and assuredly also our mind is not asleep, because it thinks; it is therefore manifest that the mind frequently wakes when the senses are in slumber. But this does not prove that it never sleeps along with them. To sleep is for the mind not to dream; and it is impossible to establish the fact that there are in sleep moments in which the mind does not dream. To have no recollection of our dreams does not prove that we have not dreamed; for it can often be proved that we have dreamed, although the dream has left no trace on our memory." Dreams, no less than our waking thoughts, are dependent on the laws of association, and the senses may be considered as the media through which the spirit within is brought into contact with the external world. Although in sleep the senses generally are torpid, some of them continue to transmit to the mind imperfect sensations which they receive. Of the five external senses, sight is the least excitable during sleep; and next in order, in proportion to their degree of excitability, come taste, smell, hearing, and touch; the last being the most excitable, and causing or modifying dreams oftener than any of the others. Dr. Gregory, having applied a bottle of hot water to his feet on going to bed, dreamed that he was making a journey to Mount Etna, and found the heat insufferable. Dr. Reid, having had a blister put upon his head, dreamed that he was scalped by Indians. M. Giron de Buzereingues made a series of experiments to test how far he could determine

his dreams at will by operating upon the mind through the senses. With this view he left his knees uncovered, and dreamed that he was travelling at night in a diligence with a vivid impression of cold knees produced by the rigor of the weather. Waller relates the case of a gentleman who was a victim of terror on account of a dream, which he could never look upon except as a real occurrence. He was lying in bed, and as he imagined quite awake, when he felt the distinct impression of a hand placed upon his shoulder, which produced such a state of alarm that he durst not move in bed. The shoulder which had experienced the impression had been uncovered, and the cold to which it was exposed produced the sensation. Persons in whom one of the senses is defective frequently have their dreams modified by this circumstance. Darwin relates the case of a deaf gentleman who in his dreams always appeared to converse by means of the fingers or in writing. He never had the impression of hearing speech, and for the same reason one who has been blind from his birth never dreams of visible objects. The condition of the digestive apparatus has a very marked influence on dreams. When the functions of the digestive organs are properly performed, the dreams, if affected at all from this cause, are pleasant; if however any disturbance exists in this part of the system, the dreams are apt to be painful, usually proportioned in intensity to the amount of disturbance of the alimentary canal. To this class of sensations may be referred those dreams produced by the use of opium and intoxicating drinks, which in part at least act by the impression made upon the digestive organs. Dreams induced by this cause are remarkable for the extravagance of the phantasmagoria they exhibit, frequently presenting shapes the most fugitive and fanciful. The dreamer often seems endowed with such elasticity that it appears as if he could easily mount to and float upon the clouds above him. De Quincey, in the "Confessions of an Opium Eater," has portrayed most vividly the effects of that narcotic in the production of dreams. But it does not require the aid of a narcotic as powerful as opium, or indeed anything beyond what ordinarily occurs in a state of dreaming, to create ideas of time and space apparently as incongruous as those narrated by the opium eater. The sleeper who is suddenly awakened by a loud rap does not begin and terminate his dream with this simple occurrence, but experiences a long train of events requiring hours and even days for their fulfilment, all evidently occasioned by the sound which awakens him, and concentrated within the brief space of time it occupies. A person who was suddenly aroused from sleep by a few drops of water sprinkled in his face, dreamed of the events of an entire life in which happiness and sorrow were mingled, and which finally terminated with an altercation upon the borders of a lake, into which his exasperated

companion, after a considerable struggle, succeeded in plunging him. It is evident that the association of ideas in this case which produced the lake, the altercation, and the sudden plunge, was occasioned by the water sprinkled upon the face, and the presumption is probable that the whole machinery of an entire life was due to the same cause. Dr. Abercrombie relates a similar case of a gentleman who dreamed that he had enlisted as a soldier, joined his regiment, deserted, was apprehended, carried back, tried, condemned to be shot, and led out to execution. After the usual preparations a gun was fired, and he awoke with the report to discover that the cause of his disturbance was a noise in the adjacent room. Kant says we can dream more in a minute than we can act during a day, and that the great rapidity of the train of thought in sleep is one of the principal causes why we do not always recollect what we dream. Dreams are often produced by the waking associations which precede them; and the most recent associations occur the most frequently in our dreams. So, too, dreams are often characteristic of the peculiar idiosyncrasies of the dreamers: a miser dreams of his gold, a philosopher of science, a merchant of his ventures, the musician of melody, and the lover of his mistress. Tartini, a distinguished violin player, is said to have composed his "Devil's Sonata" under the inspiration of a dream, in which the devil appeared to him and invited him to a trial of skill upon his own instrument, which he accepted, and awoke with the music of the sonata so vividly impressed upon his mind that he had no difficulty in committing it to paper. In like manner Coleridge professes to have composed his poem "Kubla Khan" in a dream. He had, he says, taken an anodyne prescribed for a slight indisposition, and fell asleep in his chair while reading in Purchas's "Pilgrimage" of a palace built by Khan Kubla. He continued for about three hours in a profound sleep, and awoke with a vivid impression that he had composed from 200 to 300 lines of verse. He at once wrote the fragment as it is now preserved. At this point he was called out to attend to some business. When he returned, after an absence of more than an hour, the poem, with the exception of a few scattered lines and images, had vanished from his memory. Instances like the above occasionally occur where the mind in a state of waking is aided by the processes carried on during sleep. Condillac, says Cabanis, often brought to a conclusion in his dreams reasonings which he had not completely worked out on retiring to bed; and Condorcet saw in dreams the final steps of a calculation which had baffled him when awake. But such cases are rare. As a general rule dreams are wanting in coherence and unsubstantial in reasoning. Nothing is more common than for the mind in dreams to blend together objects and events which could not have an associated existence in reality. We never dream of a past

event as past. The faces of friends long dead and events long past rise before the mind with all the vividness of real existence, and fail to excite surprise by their incongruity, because, says Dr. Hartley, "we have no other reality to oppose to the ideas which offer themselves, whereas in the common fictions of the fancy, while we are awake, there is always a set of real external objects striking some of our senses and precluding a like mistake there. . . . Secondly, the trains of visible ideas which occur in dreams are far more vivid than common visible ideas, and therefore may the more easily be taken for actual impressions."—The popular belief that in dreams an insight is frequently given of coming events is shared by many well informed persons, and is supposed to be corroborated by many remarkable cases. Some of the instances recorded may be explained by natural means. Franklin believed that he was instructed supernaturally in his dreams concerning the issue of current events. "He observed not," says Cabanis, "that his profound skill and rare sagacity continued to direct the action of his brain during sleep." The dream of Albumaron, the Arabian physician, to whom his lately deceased friend suggested in his sleep "a very sovereign remedy for his sore eyes," is explicable in a similar way. But there are extraordinary instances which cannot be explained by any known natural laws. Many of these are so well authenticated that they cannot be discredited, however loath we may be to accord to them a supernatural origin.—The earliest mention of dreams is in the Scriptures and in the poems of Homer, in both of which a supernatural origin is generally ascribed to them. By the ancients, indeed, dreams were almost universally regarded as coming from the other world, and from both good and evil sources. A great number of instances are on record in the Greek and Latin classics of remarkable dreams. The night before the assassination of Julius Cæsar, his wife Calpurnia dreamed that her husband fell bleeding across her knees. On the night that Attila died, the emperor Marcian at Constantinople dreamed that he saw the bow of the Hunnish conqueror broken asunder. Cicero relates a story of two Arcadians, who, travelling together, arrived at Megara and went to separate lodgings, one to an inn, the other to a private house. In the course of the night the latter dreamed that his friend appeared to him and begged for help because the innkeeper was preparing to murder him. The dreamer awoke, but, not considering the matter worthy of attention, went to sleep again. A second time his friend appeared, telling him that assistance would be too late, for the murder had already been committed. The murdered person also said that his body had been put into a cart and covered with manure, and that an attempt would be made to take it out of the city the next morning. The dreamer went to the magistrates and had the cart searched,

when the body was found and the murderer brought to justice. Dreams were even allowed to influence legislation. During the Marsic war (90 B. C.) the Roman senate ordered the temple of Juno Sospita to be rebuilt in consequence of a dream of Cæcilia Metella, the wife of the consul Appius Claudius Pulcher. Some of the fathers of the Christian church attached considerable importance to dreams. Tertullian thought they came from God as one species of prophecy, though many dreams may be attributed to the agency of demons. He believed that future honors and dignities, medical remedies, thefts, and treasures had been occasionally revealed by dreams. St. Augustine relates a dream by which Gennadius, a Carthaginian physician, was convinced of the immortality of the soul, by the apparition to him in his sleep of a young man, who reasoned with him on the subject, and argued that as he could see when his bodily eyes were closed in sleep, so he would find that when his bodily senses were extinct in death he would see and hear and feel with the senses of his spirit.—Aristotle wrote a treatise on dreams (*Περὶ ὄντων*), as did also Artemidorus and Astrampsyclus. Of late works, Dr. W. B. Carpenter's "Physiology" may be consulted with advantage; also Maury's *Le sommeil et les rêves* (Paris, 1861); Brierre de Boismont's *Des hallucinations, ou histoire raisonnée des apparitions, des visions, des songes, de l'extase, des rêves, du magnétisme et du somnambulisme* (Paris, 3d ed., 1861); and Maudsley's "Physiology and Pathology of the Mind" (London, 1867).

**DREBBEL, Cornelis van**, a Dutch philosopher and inventor, born in Alkmaar in 1572, died in London in 1634. Of his life little is known; but his inventive genius appears to have given him a wide reputation, for it is certain that when about 30 years of age he was in receipt of a pension from the emperor Rudolph II., granted him for scientific discoveries. He was also taken into favor by the future emperor Ferdinand II., and made tutor to his son. Seditious movements about the beginning of the thirty years' war led to his arrest; and he would have been executed but for the intercession of King James I. of England, who took him under his protection. He lived in London from 1620, devoted entirely to scientific labors. He invented several philosophical instruments, among which, it is said, were the compound microscope and a thermometer consisting of a glass tube containing water connected with a bulb containing air. His contemporaries say that he displayed to King James a glass globe in which by means of the four elements he had produced perpetual motion, and that by means of machinery he imitated rain, thunder, lightning, and cold, and was able quickly to exhaust a river or lake. He discovered a bright scarlet dye for woollens and silks, which was introduced into France by the founders of the Gobelins manufactures.

Drebbel left two treatises, which appeared first in Dutch (Leyden, 1608); afterward in Latin, under the title *Tractatus duo: De Natura Elementorum; De Quinta Essentia* (Hamburg, 1621); and in French (Paris, 1673).

**DREDGING**, the process of excavating the sediment that collects in harbors and channels; the term is also applied to the scooping up of oysters, or anything else, from the bottom. The drainage waters and even the ebb tide have sometimes been held back by floodgates, and the waters at last let out have rushed with great violence through the channels, sweeping forward the materials that obstructed them. This is the principle of flashing or flushing applied to sewers, and is the most efficient mode of dredging. In some of the harbors in England scouring basins have been constructed especially for this purpose, as at Ramsgate and Dover. To loosen the sediment, the Dutch long since contrived a floating frame to which bars were attached, that went down to the bottom and stirred up the mud, as the machine moved along with the current. These are perhaps the oldest dredg-

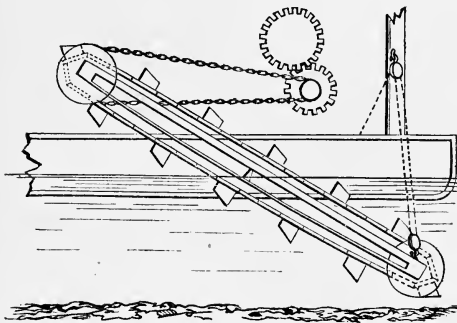

FIG. 1.

ing machines. The dredging machine now generally used for deepening channels and harbors is an endless chain with scoop buckets, placed in a frame which may be raised or lowered through a well in the middle of the scow upon which the apparatus and the machinery for moving it are placed. The diagram, fig. 1, will afford an idea of the general principles of its construction and use. The mud may be received in a shoot, and conveyed to an adjoining scow, or the frame may be made long enough to reach beyond the side of the vessel, and discharge itself without the intervention of the shoot. Another kind of dredging machine, which is used in soft bottoms, especially where old piles remain that would interfere with the working of the endless chain and scoops, is shown in fig. 2. It is a very efficient form, sinking into the mud and filling itself readily, and is strong enough to draw old piles from their beds. The same form of dredge on a smaller scale, usually worked by hand by means of a windlass, although sometimes by steam power, is used for

dredging for oysters in their natural beds. A smaller kind, usually called tongs, is used to gather oysters from artificial beds. It is constructed by placing two rakes, having iron

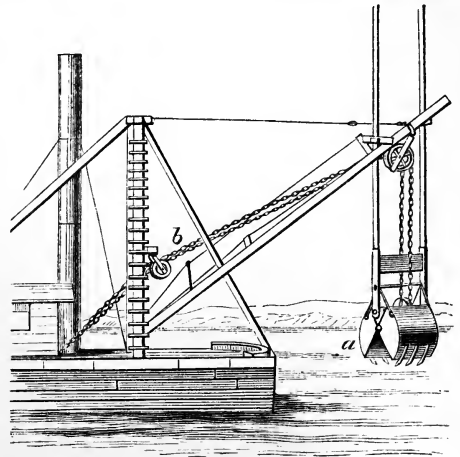

FIG. 2.

heads and long wooden handles, with their teeth turned toward each other, and uniting them by a hinge like that in a blacksmith's tongs or a pair of shears.

**DREDGING, Deep-Sea**, an operation much resorted to by modern naturalists to investigate the bottom of the sea and its inhabitants. It has added vastly to our knowledge of the animal kingdom in general, of its distribution in depth, and of the important part it plays in the formation of the superficial layers of the earth. The first naturalist who appears to have made use of the dredge was Otto Frederik Müller, a Danish zoölogist of the last century, who obtained by its means a large portion of the specimens described by him and figured so beautifully by his brother in the *Zoologia Danica*. The description of his *sacculus reticularis*, as he calls it, and of the alternate joys and disappointments of the dredge, is very amusing. A small figure of the instrument is given among the allegorical ornaments of the title page, and has been reproduced in Thomson's "Depths of the Sea." That same dredge was afterward purchased by Tilesius, the naturalist who accompanied Krusenstern in his journey round the world, and after his return it was deposited in the academy of St. Petersburg. It consisted of a square frame, each side being in the shape of a scraper. A bag of netting was attached to it, and four iron arms were hinged at the corners and met in a ring to which the rope was attached. Little was heard of dredging after Müller's time until about 1838, when Dr. Robert Ball of Dublin introduced the modern dredge, commonly known as Ball's dredge. This is oblong, with only two scrapers and two arms. For dredging from a rowboat 18 in. by 5 is a convenient size. The scrapers may be

3 or 4 in. wide, sharp at the forward edge, and pierced with holes at their hinder and thicker edge. To these holes the net, made of strong twine, and a protecting cover of canvas open at the bottom, are fastened with copper wire. The iron rings passing through the holes in the frame, and the iron rod running through the rings as used in recent English expeditions, appear to be unnecessary complications. The net ought to have small meshes, about half an inch to the side, and may be lined near the bottom with some open canvas to retain the smaller specimens. In the United States coast survey dredgings it was found convenient to have the net open at the bottom and to tie it up with a rope yarn; this gives greater facility for emptying it, and the numerous folds formed in the bottom of the bag have a great retentive power for small objects. A stout wire bent in a bow inside the net, and hooked by its ends to the frame, is useful in preventing the net from being turned inside out in going down. The bag has also been made occasionally of strong canvas, with windows of copper or brass wire gauze on each side; but this construction seems to afford too much facility for washing out, unless the bag is of considerable length. Dredges have also been made of two sides of hide, laced all round with a small line; this works well on coral ground, but not elsewhere. Some of the Scandinavian and German naturalists use triangular dredges, having three scrapers and three arms. The two arms of an ordinary dredge are made each of a double or forked rod of iron, hinged on the small ends of the frame, and forming a ring at the outer end. The dredge rope passes through the ring of one of the arms only, the other arm being made fast or stopped to the first by a few turns of spun yarn. By this arrangement, in case the dredge is caught, the stop, being the weakest part, breaks first, and the rope pulling on one arm only, the dredge disengages itself and comes up endwise. For use from a steamer the dimensions of the dredge may be larger. Those used in the Porcupine expedition were 4 ft. 6 in. long by 6 in. wide. Capt. Calver of the Porcupine, having observed that frequently objects came up adhering to the outside of the bag and even to the line, attached to the dredges some of the swabs used for washing decks. The frayed hemp swept up every rough or spiny object with which it came in contact; and among the dwellers of the deep, crustacea, bryozoa, echinoderms, polyps, and sponges nearly all partake of those qualities. Smooth shells, and those which burrow in the sand, alone escape the "hempen tangles." In one case Prof. W. Thomson estimates that not fewer than 20,000 specimens of *echinus Norvegicus* came up in the tangles at one haul. These are best attached to an iron bar fixed transversely to the bottom of the bag, or in very rocky bottom they can be used without the dredge. In the expedition of the United States steamer Hassler they were successfully

used attached to a long bundle of rattans, which yields when in contact with rocks, and adapts itself to the inequalities of the bottom; it is of course loaded sufficiently with lead. The *salabre* of the coral fishers of the Mediterranean is constructed on the same principle. It is a heavy wooden cross, carrying at the end of the arms large bunches of old tattered nets and swabs. It is kept horizontal, and lifted and dropped alternately a number of times, thus breaking off the branches of coral which are entangled in the nets. In the recent expedition of the British ship *Challenger* it was found practicable to use in great depths the trawl net, with which European fishermen procure fishes living close to the bottom. It consists of a wooden beam 12 to 15 ft. long, provided at the ends with iron supports like the runners of a sled, which keep it one or two feet from the ground. A large bag net is laced to the beam by one edge of its mouth, while the other, kept down by leaden sinkers, drags on the ground. Besides fishes, many crustaceans can be procured with it, which either swim close to the bottom or rise from the sand at the approach of the beam. A miniature trawl net is used by some naturalists in small depths for the lesser crustacea or radiata, the bag being made of bunting and the frame of hoop iron. The rope or line used in dredging must be made of the best materials, Russian or Italian hemp, and of a size to resist at times a very heavy strain. The deeper the dredge is to be used, the stronger the line must be. In the Porcupine, lines from 2 to 2½ in. in circumference were used, the latter having a breaking strain of 2½ tons. In the United States coast survey, lines from 1½ to 2 in., of Italian hemp, were mostly used. In dredging from a boat or a yacht depths from 100 to 200 fathoms can be reached. If the boat drifts considerably by the effect of the wind or current, it is necessary, unless the dredge is very heavy, to attach a lead to the line a few fathoms above the dredge; otherwise it is apt to be lifted clear of the bottom. The length of the line paid out is usually about twice the depth.—Deep-sea dredging, that is, dredging in more than 200 fathoms, necessitates the use of a steamer and of a donkey engine to bring up the dredge. The line passes over a large block suspended from a derrick or boom. The rope to which this block is attached passes through another block or a bull's-eye, and thence through an accumulator to the deck, where it is made fast. This accumulator is a combination of 30 or 40 strong India-rubber springs held apart by two wooden disks, and is very useful in indicating the strain on the line, which when too great can be relieved by a few turns of the engine. The line (which is marked for every hundred fathoms in the manner of a sounding line) is conveniently coiled in succession on a row of large iron pins projecting inward from the top of the bulwark. On board the Hassler stout

hooks of galvanized iron were hinged inside the bulwark in such a way that they could be turned flat against the latter when not in use. It is not usually practicable to pay out so large a surplus of line in deep casts as in more moderate ones. It is therefore well to attach a heavy weight to the line at a considerable distance above the dredge, say a fifth or a sixth of the depth; thus the traction on the dredge will be nearly horizontal. Another good practice in very deep casts is to steam slowly to windward during the descent of the dredge until the dredge rope is nearly perpendicular, and then let the vessel drift with the wind or current. The motion is thus communicated to the weight from the vessel, and the dredging performed as if from that and not from the latter. The contents of the dredge will generally be found to consist of mud or sand, out of which the specimens are to be sorted. For this a graduated set of sieves is used, constructed so as to fit in one another, the coarsest on top. The mud being placed in the latter, the whole set is moved up and down in a tub of water, after which the specimens can be selected with ease. The best mode of preserving them is to put them in alcohol, the more delicate ones in bottles, the coarser ones in bags of muslin or bunting, which can be accumulated in larger vessels. Some very delicate objects, which are liable to lose their shape in pure alcohol, can be preserved successfully in a mixture of alcohol and glycerine. Superfluous duplicates of mollusks, crustacea, echinoderms, corals, and sponges can be preserved by drying. Care must be taken not to place colored horny sponges in the same vessel with other specimens, as they are apt to stain everything as with ink. Abundant samples of the sand or mud ought to be preserved, as they afford an immense variety of microscopical specimens of great value.—An erroneous opinion prevails that the late American and English expeditions first revealed the existence of an abundant deep-sea fauna. The late Edward Forbes asserted that life becomes less and less as we descend, until it is almost or utterly extinguished. Guided by his own researches in the Mediterranean, he placed the limit of life at the very moderate depth of 200 to 300 fathoms. Norwegian fishermen, from time immemorial, have taken certain fishes in depths of 100 to 300 fathoms. Some of these are quite large, as the halibut and the ling, and some have never been obtained in lesser depths. On the coast of Portugal also the fishermen of Setubal fish in similar depths for a peculiar shark, using lines of 500 fathoms. It is evident that where such fishes can live they must find abundant food, and this was proved by the contents of their stomachs, and by the specimens occasionally brought up on the hooks, but mostly rejected with superstitious dread by the fishermen. The Scandinavian naturalists Lovén, Sars, Danielssen, Koren, and others, made extensive researches by means of the dredge in depths of 200 to 300 fathoms,

bringing to light a great variety of animal forms peculiar to that region. Sir John Ross relates in his "Voyage," published in 1819, that in the preceding year he obtained a sounding in Baffin Bay in 1,000 fathoms, and brought up with the lead mud containing worms, and a living star fish (*astrophyton*) attached to the line. Sir James C. Ross, in his voyage to the antarctic regions in 1839-'43, obtained with the dredge in 270 fathoms "an abundance and great variety of animal life." He says: "Contrary to the general belief of naturalists, I have no doubt that from however great a depth we may be able to bring up the mud and stones of the bed of the ocean, we shall find them teeming with animal life. The extreme pressure at the greatest depth does not appear to affect these creatures; hitherto we have not been able to determine this point beyond 1,000 fathoms, but from that depth several small fish have been brought up with the mud." At a later time evidences of the existence of animal life at great depths began to accumulate. Ehrenberg showed in 1851 that foraminifera from a depth of 2,000 fathoms still contained unchanged animal matter. Prof. Bailey of West Point confirmed these observations, although differing in the explanation of the fact. In 1853 the soundings of the United States coast survey revealed for the first time the great foraminifera bed which almost unmixed covers a large extent of the ocean floor. In a sample of scarcely two cubic inches, from a depth of 510 fathoms, Mr. Pourtalès found specimens or recognizable fragments of at least 48 species, 20 of them mollusks. Dr. Wallich, accompanying the sounding expedition of Sir L. McClintock to Greenland, obtained living animals from depths of 1,000 to 2,500 fathoms, among them star fishes of considerable size. Doubt was still thrown on these results from the fact that some foraminifera are found floating near the surface, and it was even objected that the star fishes might have been swimming when entangled in the line. No such objections could be made to the observations of Dr. Allman and A. Milne-Edwards, who found oysters and other shellfish, worms, and corals on a telegraph cable raised from a depth of 1,000 to 1,400 fathoms in the Mediterranean; or to the results of the Swedish expedition to Spitzbergen, under Thorell, who obtained, partly by dredging and partly by means of the Bulldog machine, extensive collections from depths down to 1,400 fathoms. In 1868 Prof. Sars of Christiania published a list of 427 species of animals living in depths of 200 to 300 and even as much as 450 fathoms. In the United States, dredging up to a recent date has received but little attention. The most successful worker in that field has been the late Dr. W. Stimpson, who however confined himself to quite moderate depths. In 1867 Professor Peirce, superintendent of the coast survey, commissioned Mr. Pourtalès, one of his assistants, to make some dredgings in connection with the sounding out



of a track for the submarine telegraph between Key West, Florida, and Havana. Although but a few casts were obtained in that year, and the depths reached did not exceed 500 fathoms, the results were so promising that dredgings were carried out systematically over the region comprised between the Florida reef and the axis of the straits of Florida, with occasional extensions to the coast of Cuba and the Bahama banks, during the two following years. This is probably at this time the only example of a connected dredging survey of a defined submarine region. The results established several well defined zones characterized by peculiar faunæ, the animals comprising them being generally new discoveries, or in several cases known only from high northern latitudes, thus bearing out in part Lovén's theory that beyond a certain depth the ocean is peopled by a fauna extending from pole to pole. In these explorations the greatest depths reached were about 700 fathoms. One of the most notable examples of an animal found in Florida and off the northern coast of Norway is the little crinoid *rhizoerinus Lofottensis*, discovered the year previous by Sars. This seems to have been one of the principal incentives in determining the fitting out of the deep-sea dredging expeditions of the Lightning and Porcupine by the British government, under the direction of Profs. W. Thomson and W. B. Carpenter. The first cruise in the Lightning was made in 1868, between the British and the Faroe islands, with very promising results. The next year the Porcupine was employed on the same service, off the W. and S. W. coasts of Ireland. The depth of 2,435 fathoms was attained by the dredge, which brought up quite a variety of living animals, ranging from mollusks and crustacea downward. During the following summer the same researches were extended across the bay of Biscay, along the coast of Portugal, and into the Mediterranean, with great success generally, though in the latter sea the greater depths were found singularly barren, probably on account of the want of circulation in the water. (See ATLANTIC OCEAN.) The British government was induced by the general interest which these researches had created to fit out a large ship, the Challenger, for a cruise of deep-sea exploration on a large scale, which in 1872 started, under the scientific leadership of Prof. W. Thomson, on a voyage of circumnavigation. In the earlier part of the voyage, in the Atlantic, the dredge was used with success in the depth of 3,895 fathoms. A few deep-sea casts were also made during the voyage of the United States steamer Hassler from Boston to San Francisco in 1872, but did not attain so great a depth. In 1871 the United States fishery commission, directed by Prof. S. F. Baird, made extensive explorations of the sea bottom on the coast of New England, Prof. Verrill and Dr. Packard having charge of the dredging operations. Deep-sea dredgings were

made off St. George's bank and in the gulfs of Maine comprised between Cape Cod and Cape Sable. The fauna, as might have been expected, was entirely arctic, with the exception of a single specimen of a small coral, *deltocyathus*, a West Indian deep-sea form, the presence of which north of Florida had not been detected before.—Dredging in deep water has greatly increased our knowledge of the animal world, and precisely at a time when the need of such a knowledge is most keenly felt. The great bed of foraminifera has already been mentioned. A gelatinous matter pervades this bed in most localities, which under the microscope seems to be endowed with a kind of motion or change of form, and has thence been raised to the dignity of a living organism under the name of *bathybius Hackelii* by Huxley. Its nature is really as yet but imperfectly understood. The same may be said of small calcareous bodies which have been named coccoliths. (See BATHYBIUS, and COCCOLITHUS AND COCCOSPHERES.) The sponges are represented by a number of forms, having generally a beautiful silicious skeleton. Then come a considerable number of small corals, generally simple. The echinoderms are abundant and peculiar; among them the most notable are the crinoids. The *rhizoerinus Lofottensis* has been found in the straits of Florida and in the seas of Europe. Another species has been recently discovered in the West Indies by the Hassler expedition, in company with two species of *pentacrinus* and the remarkable *holopus*. Another *pentacrinus* and *bathyerinus gracilis* belong to the European seas. The sea urchins or *echinidæ* of great depths are very remarkable, and among them several genera are represented much more nearly related to forms of the cretaceous or early tertiary period than to any recent ones. Of the mollusks we know less than of the other classes; partly because the collections of the American dredging expeditions were lost in the great fire of Chicago, and partly because the English collections have not yet been fully worked up. What we know at present points to the same conclusions as derived from other branches of the animal kingdom.—Deep-sea researches are also extending the science of geology, particularly as it refers to sedimentary rocks. The dredgings off the Florida reef brought up large fragments of limestone rock in process of formation, and of different grades of compactness, formed by the various mollusks, bryozoa, serpulæ, corals, foraminifera, &c., still living on its surface. On other parts of our southern coast we have the beds of foraminifera gradually undergoing transformation into glauconite or greensand, such as we find in the tertiary formation of New Jersey. This process, as yet unexplained, takes place in comparatively limited localities, while the great bed of foraminifera becomes compacted without alteration into a formation almost identical with the white chalk; and the continuity of that formation

to the present time has been advocated by Huxley, Thomson, and others. A considerable proportion of the deep-sea foraminifera are undistinguishable specifically from those of the chalk; but all the higher forms inhabiting the deep sea, polyps, echinoderms, crustacea, and mollusks, are with one or two doubtful exceptions only generically related to those of the cretaceous and tertiary periods. It may here be remarked that but little distinction has heretofore been made by geologists between formations deposited in deep and in shallow water, and that we are unduly struck by resemblances brought up suddenly before our eyes by the revelations of the dredge. Deductions will therefore not be safe until we acquire a fuller knowledge of the bathymetrical relations of fossil forms, so that we can compare those of a particular level with those of the corresponding level of the present seas.

**DRELINCOURT, Charles**, a French Protestant divine, born at Sedan, July 10, 1595, died in Paris, Nov. 3, 1669. He pursued his studies in his native town and in Saumur, preached for two years near Langres, and in 1620 became pastor at Charenton, near Paris. He soon distinguished himself as a preacher, being one of the first of the reformed ministry who treated their texts practically, instead of discussing them in a doctrinal and abstract way. Some of his writings, especially his book of "Consolations against the Fear of Death" (Paris, 1651), which has been translated into English and German, are still in use as books of devotion. It was to promote the sale of the English translation of this work that Defoe wrote his celebrated fictitious account of the apparition of Mrs. Veal, who came from the other world on purpose to recommend the perusal of "Drelincourt on Death."

**DRENTHE**, a N. E. province of the Netherlands, bordering on the Prussian province of Hanover and the provinces of Groningen, Friesland, and Overijssel; area, 1,031 sq. m.; pop. in 1871, 108,056. It lies on each side of the watershed between the Zuyder Zee and the Dollart, and its surface is generally more elevated than that of the surrounding provinces. Several streams rise within it, the principal of which are the Hunse and the Drentsche Aa, and there are a number of small lakes. The soil is poor and sandy, and only about half of it is capable of cultivation; the remainder consists of heaths, bogs, marshes, and sand wastes. The chief industry is the breeding of horses, which are sent as foals into Friesland to be reared. Cattle, sheep, swine, and poultry of fine quality are also raised. On the western border are the colonies of Willemsoord and Frederiksoord, where large numbers of paupers are employed in brick-making, spinning, weaving, tanning, cutting peat, reclaiming waste lands, &c. Assen, the capital, is connected with Meppel, the chief town, by canal and railway. In the south part of the province is the strong fortress of Koeverden.

**DRESDEN**, the fourth city of the German empire in point of population, capital of the kingdom of Saxony and of a circle of its own name, in lat. 51° 3' N., lon. 13° 44' E., 99 m. S. by E. of Berlin and 61 m. S. E. of Leipsic, lying on both sides of the Elbe, in the midst of a fertile valley, and in the neighborhood of the most picturesque scenery of the kingdom; area of the circle, 1,627 sq. m.; pop. of the circle in 1871, 677,671; pop. of the city, 177,089, nine tenths Lutherans. The city consists of four portions, viz.: the Altstadt with its three suburbs (the Pirnaische Vorstadt, See-Vorstadt, and Wilsdruffer-Vorstadt), on the left bank of the Elbe; the Friedrichstadt, separated from the Altstadt by the narrow channel of a small stream, the Weisseritz; the Neustadt, on the right bank of the Elbe; and the Antonstadt, lying E. of the Neustadt on the same side of the river. The village of Stadt-Neudorf has recently been incorporated with the Neustadt; and the private purchase of large tracts of the public lands lying north of the former limits has also added somewhat to the extent of the city, which now contains, besides its public buildings, about 6,000 houses and 300 streets, and about 80 squares and places. The chief thoroughfares are the Schloss, Prager, See, Pirnaische, and Wilsdruffer streets, in the Altstadt and its suburbs; the Weisseritz and Schäfer streets, in the Friedrichstadt; the Hauptstrasse, the Leipziger and Grosse Meissner streets, in the Neustadt; and the Bautzner, Anton, and Schiller streets, in the Antonstadt. The chief squares in that part of the city on the left bank of the Elbe are the Altmarkt and Neumarkt, the Schlossplatz, Theaterplatz, Antonsplatz, and Wilsdrufferplatz; on the right bank, the Bautznerplatz, Neustädtermarkt, and Palaisplatz. Two bridges across the Elbe connect the various portions of the town. The Altbrücke, built entirely of stone, crosses from the Schlossplatz, which lies on the river at its abrupt bend in the centre of the city, to the Neustädtermarkt, and forms the most frequented passage from the old town to the new. It was constructed in the 13th century, renewed in the 14th, embellished in the 18th, and restored in 1814, after its partial destruction by the French in the preceding year. It is 1,420 ft. long, has 16 arches, and is of the most solid structure, having to resist the force of the spring freshets of the Elbe, which not infrequently rises during the time of melting ice 16 ft. in 24 hours, with a current of great violence. Jean Paul Richter called this bridge "the triumphal arch of Dresden" (*Dresdens Triumphbogen*). From its centre one of the best views of the city is obtained. Somewhat more than half a mile below this is the shorter Marienbrücke of 12 arches, over the Elbe just above the mouth of the Weisseritz. It is crossed by a railway connecting all the routes of railway travel to and from the city: the Leipsic and Silesian railways, the stations of which are in the Neustadt, with the Bohemian and

Freiberg railways, having their stations on the southern outskirts of the See-Vorstadt. A new bridge above the Altbrücke has been projected, and in 1871 the city authorities appropriated 300,000 thalers to its completion. Three small bridges across the Weisseritz connect the Friedrichstadt with the Altstadt.—Dresden is in appearance rather a pleasing and attractive than a striking or imposing city; yet it abounds in buildings of great architectural beauty, and its principal streets and promenades are laid out with much taste and skill. The principal public buildings of interest surround the Theaterplatz, which is thus, as well as by its situation near the river and the Altbrücke, made the centre of attraction in the old town. On that side of the square furthest from the Elbe is the Zwinger, an immense structure in the most elaborate rococo style of architecture, begun in 1711, and at

first designed to form only a portion of a still larger palace. For more than a century it occupied three sides of a square, the fourth, toward the Theaterplatz, remaining open; but in 1846 the so-called new museum was built across this space. The royal palace, an extensive, irregular building, was begun in 1534 by Duke George the Rich, but greatly enlarged and changed by his successors, so that it can hardly be said to follow any one system of construction. Its most conspicuous feature is a tower 370 ft. high. Near it is the smaller palace of the crown prince. A little to the north is the Catholic church, finished in 1756; its altarpiece is a painting by Raphael Mengs, "The Ascension," one of the most celebrated pictures in Dresden. The funeral vaults of the royal family of Saxony are underneath the sacristy. Near the northern end of the Theaterplatz, giving it its name, stood the royal

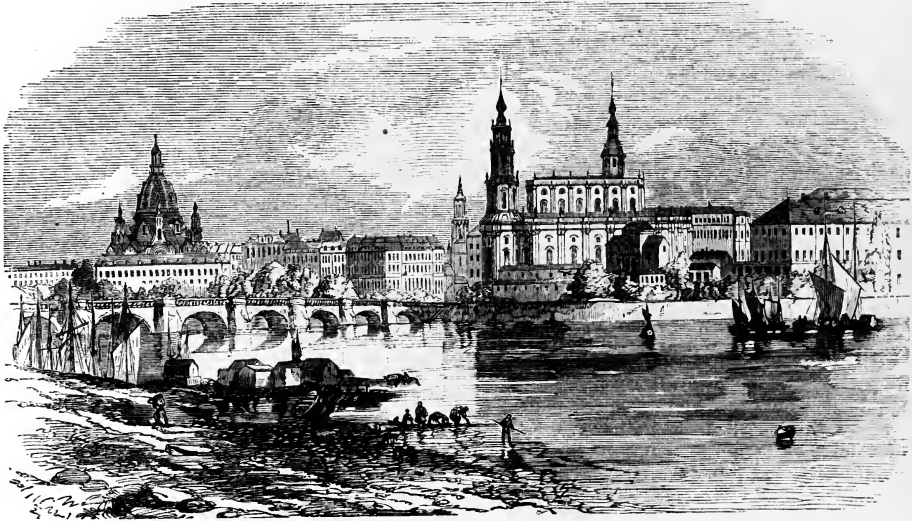

Dresden, from the left bank of the Elbe.

theatre till Sept. 21, 1869, when it was entirely destroyed by fire. It was built under the superintendence of the architect Semper in 1838-'41, thoroughly renovated in 1864, and was justly celebrated as one of the most beautiful theatres of Germany. A new building a little north of the former site is now (1874) in course of construction by the same architect. Besides those in the Theaterplatz, the Altstadt contains a considerable number of other prominent buildings. The Brühl palace, built in 1737 by the minister whose name it bears, and only separated by a garden in its rear from the Brühl terrace, a beautiful and well kept public promenade on the bank of the Elbe, served as the headquarters of the provisional government established in Dresden in 1813, as the meeting place of the Dresden conferences of 1850-'51, and more recently as the residence of the queen dowager of Saxony. It is an im-

posing building, but without great architectural beauty. Near it is the academy of fine arts (*Kunstakademie*). Further east, and near the Brühl garden at the end of the terrace, is the Zeughaus or arsenal, of which the most ancient part was built in 1559-'65, the addition in 1740. The post office and the polytechnic school are large and well arranged modern structures, at opposite ends of the Antonsplatz. The town hall, in the Altmarkt, is another conspicuous public building, but is without especially interesting architectural features. In the suburbs the chief buildings worthy of remark are the orangery, in the Wilsdruffer-Vorstadt, a massive structure with elaborate ornamentation; the large hospital in the Freiburgerstrasse; and the great railway station in the Wienerstrasse (See-Vorstadt). In the Neustadt, the Japanese palace, built by Augustus I. as a summer residence, but now used

as a museum, is the most important structure. It stands near the Elbe, in the midst of pleasant gardens, and not far distant from the Leipsic gate. The Dreikönigskirche, with a tower about 300 ft. in height, and the Catholic church, are conspicuous buildings. The most noteworthy of the public resorts of the citizens is the Grosser Garten, a beautifully laid out and carefully kept park a short distance outside the city. A zoölogical garden of considerable interest is also maintained by the government, and there are several smaller gardens of some beauty. There are comparatively few public monuments in Dresden. An equestrian statue of Augustus the Strong stands in the Neustädtermarkt; a fine drinking fountain, in the Gothic style, ornaments the Postplatz; and several statues embellish the steps of the public buildings. Four pieces of sculpture by Johannes Schilling, typifying morning, noon, evening, and night, have recently been placed on the Brühl terrace.—The art collections of Dresden enjoy a world-wide celebrity, and are among the finest in Europe. The great gallery of paintings in the museum contains some of the most valuable of existing works of art. Here are the Sistine Madonna of Raphael and Correggio's famous *Notte* (the night of the birth of Christ), with other works of both artists, and excellent specimens of the paintings of all the leaders of the great European schools. Titian, Andrea del Sarto, Paul Veronese, Giulio Romano, Guido Reni, Carlo Dolci, Leonardo da Vinci, and Annibale Carracci are among the Italian masters represented; Rubens, Van Dyke, Douw, and Teniers among the Dutch; and Nicolas Poussin and Claude Lorraine among the French. The gallery is remarkably well arranged, and is of course free to the public, being open every day from 9 till 4 o'clock. A very curious and valuable collection of objects of art and of rare jewels and relics is that of "the Green Vault" (*das grüne Gewölbe*), named from the place of its deposit in the long range of vaulted rooms on the ground floor of the royal palace. Here have been brought together some of the most costly treasures in the world: rare carvings, some by Michel Angelo, and beautiful specimens of workmanship in gold, silver, precious stones, amber, porcelain, enamel, ivory, and bronze. Immense sums have been spent upon this collection by the Saxon princes, especially by those of the last century, who were the purchasers and contributors of the costliest articles. In the Japanese palace there are collections of antique sculpture, coins, china, and pottery, and miscellaneous objects of artistic and historic interest; in the Zwinger there is a large and valuable museum of natural history. The royal public library is also in the Japanese palace. In some departments it excels almost all other German libraries, its historical works being especially numerous and noteworthy. It contains about 350,000 volumes, with nearly 200,000

pamphlets, and 3,000 manuscripts, besides about 2,000 incunabula. Other libraries are the *Secundogenitur-Bibliothek* (a library descending in the younger branch of the royal family), the library of the academy of medicine and surgery, and that of the natural history museum.—The educational institutions of Dresden are numerous. There are two gymnasia, a polytechnic school, a royal military academy (*Cadettenhaus*), and many public and private schools, Protestant and Catholic, and of various grades. Among institutions for charitable or disciplinary purposes are the founding asylum, orphan asylum, reform school for boys, the Pestalozzi institution (*Pestalozzistift*), the city hospital (400 beds), the Catholic hospital, and the asylum for deaf mutes and for the blind. The prosperous condition of the institutions of art and science in the city is largely attributable to the efforts of the numerous artistic and learned societies existing here. At the head of these are the royal academy of arts and the Leopold-Caroline academy of investigators in natural science (*Akademie der Naturforscher*). Political and trade societies are very numerous, and almost every branch of industry prominent in Dresden has its representation in one of these. The leading newspapers are the government organ, the *Dresdener Journal*, the *Constitutionelle Zeitung*, and the *Dresdener Anzeiger*.—The chief industries of Dresden are the manufacture of machinery (especially of agricultural machines of various kinds), mathematical and philosophical instruments, musical instruments, gold and silver wares, china, and porcelain, the preparation of leather, and the manufacture of leather goods. The favorable situation of the city with regard to the central region of northern Germany makes it the centre of a brisk trade, and the multitude of strangers constantly visiting the place largely contributes to its prosperity.—Dresden was founded about 1206, and attained importance so rapidly that in 1216 it was mentioned as a city in official documents, and soon after it was taken under the direct government of the margrave of Meissen, after having previously been under the rule of the Meissen bishopric, for many years one of the richest and most powerful in Germany. In 1270 Dresden became the margrave's residence, but for only one generation, as the city was sold to Wenceslas of Bohemia, and afterward to the margrave of Brandenburg. In 1319 it again came into the possession of the house of Meissen, then represented by Frederick the Bitten. In 1485, when the margraviate was divided, Dresden fell to the share of the margrave Albert, under whom it began to enjoy great prosperity. In 1491 it was almost entirely destroyed by fire; but it was immediately rebuilt with many great improvements. It was fortified in 1520–28, and the fortifications were strengthened and enlarged in 1547. In 1553 the city was paved and greatly improved by

the construction of new streets and buildings. A century later it was still further beautified through the erection of an opera house and other places of amusement, and through the laying out of the great garden. In 1686 that part of the town on the site of the present Neustadt was destroyed by fire; but it was rebuilt with very great improvements by Augustus I. in 1724. Under that prince and Augustus II. the city enjoyed perhaps its brightest period. The Friedrichstadt was founded by Augustus I. in 1730; new buildings and institutions were founded by both the kings; and the prosperity of Dresden was only checked by the seven years' war, during which another great fire swept away the Wilsdruffer-Vorstadt and the Pirnaische Vorstadt, and the whole city suffered greatly through the bombardment it endured in 1760. From the close of the seven years' war until the beginning of the present century it enjoyed a period of comparative peace, and had recovered much of its old beauty and prosperity when the wars of Napoleon subjected it to many evils, the chief of which was the constant quartering of large detachments of French troops within its walls; and 20,000 wounded were brought into the city after the battle of Bautzen. On Aug. 26, 1813, the French in Dresden were attacked by the allied armies, but Napoleon, by advancing large reinforcements, won on the 27th the battle that ensued (battle of Dresden). On Oct. 7 he left the city with the principal part of his army; the Russians soon after succeeded in surrounding the place, and the French garrison of 30,000 men left in it was compelled to surrender, Nov. 11. After the restoration of peace the fortifications of the city were removed, the work being completed in 1817. Many improvements were made under King Anthony, whose name was given to the Antonstadt. During the insurrection of September, 1830, Dresden was the centre of the agitation for constitutional government, and witnessed much disturbance. In the insurrectionary movements of May, 1849, it suffered from popular violence, streets and prominent buildings being injured by the insurgents. Measures were taken in 1874 for the removal of all military establishments to the outskirts of the city.

**DREUX**, a town of France, in the department of Eure-et-Loir, on the Blaise near its junction with the Eure, 20 m. N. by W. of Chartres; pop. in 1866, 7,237. It is situated in a pleasant valley commanded by a high hill, on which are the remains of the castle of the ancient counts of Dreux. The space within its walls is now a garden, in which stands the magnificent Greek temple built by Louis Philippe for the mausoleum of the Orleans family. In the town the hôtel de ville and the parish church, a handsome Gothic structure, are the principal buildings. The chief manufactures are serges and woollen hosiery. There are also iron foundries, tan yards, and dye works, and a trade in cattle, sheep, and grain.—Dreux was called

by the Romans *Durocasses*, which, contracted into *Drocæ*, was the origin of the modern name. It was one of the early acquisitions of the Northmen in France, and became the capital of the Norman county of Dreux, which was taken by Robert II. in the 11th century, and was afterward held by members of the royal family till 1585, when it was sold to the house of Nemours. It returned to the crown under Louis XV. The town was burned by the English in 1188. In 1562 a bloody battle was fought near it between the Catholics and Protestants, in which the latter were defeated and the prince of Condé, their commander, taken prisoner. In 1593 Henry IV. captured the town after a siege of 12 days. In November, 1870, it was occupied by the German troops.

**DREW**, a S. E. county of Arkansas, drained by Bartholomew bayou and affluents of the Saline river; pop. in 1870, 9,960, of whom 3,854 were colored. The area was about 900 sq. m., but a portion has recently been taken for Lincoln county. It is nearly level, and has a fertile soil. A great part of the land is covered by forests of cypress, ash, &c. The chief productions in 1870 were 8,828 bushels of wheat, 222,140 of Indian corn, 9,850 of oats, 32,775 of sweet potatoes, and 6,661 bales of cotton. There were 1,284 horses, 3,079 milch cows, 6,111 other cattle, and 12,613 swine. Capital, Monticello.

**DREW, Samuel**, an English clergyman, born at St. Austell, Cornwall, March 3, 1765, died March 29, 1833. He was apprenticed to the shoemaker's trade, and his early education was limited. In 1788 he became a local preacher of the Wesleyan church. He pursued an extensive course of reading, and early attempted authorship. His gains from literary work induced him to leave the shoemaker's trade in 1809. In 1819 he became editor of the "Imperial Magazine," published at Liverpool, which under his management was eminently successful; and he continued to edit it after its removal to London until the year of his death. In 1824 Marischal college, Aberdeen, bestowed on him the honorary degree of A. M., and soon after he was offered a professorship in the London university. His chief works are: "Remarks upon the First Part of the Age of Reason, by Thomas Paine" (3d ed., 1799); "Essay on the Immateriality and Immortality of the Soul" (1802); "Essay on the Identity and general Resurrection of the Body" (1809); "Life of Dr. Coke" (1816); and "Treatise on the Existence and Attributes of God" (2 vols., 1820).

**DREYSCHOCK, Alexander**, a German composer, born at Zack, Bohemia, Oct. 15, 1818, died in Venice in April, 1869. He studied four years under the direction of Tomascheck, and in 1838 undertook his first tour as a pianist through northern Germany. The years 1840 to 1842 were passed in Russia, after which he was repeatedly heard in all the principal European cities. In 1862 he was appointed pro-

fessor in the conservatory of St. Petersburg, and in 1865 pianist to the emperor. He was also chapelmaster to the grand duke of Hesse-Darmstadt. As a player he was distinguished for his grace and expression, for great facility in left-hand passages, and the astonishing rapidity of his octave playing. He published more than 140 works, which are marked for their clearness, symmetry, and fine singing style. They consist of military rondos for piano and orchestra, sonatas, studies, fantasias, nocturnes, songs without words, and the like.

**DREYSE, Johann Nikolaus von**, a German mechanician, inventor of the needle gun, born at Sömmerda, Prussia, Nov. 20, 1787, died Dec. 9, 1867. He was the son of a locksmith, and worked at his trade in Germany till 1809, when he went to Paris, and was employed there in a rifle factory till 1814. After his return to Sömmerda he made models for machinery, and established an ironware factory. In 1824 he received a patent for the manufacture of percussion caps, and in 1825 one for a steam engine worked by a generator instead of a boiler. In 1827 he completed his invention of the muzzle-loading, and in 1836 that of the breech-loading needle gun, under the patronage of the Prussian government. The breech-loader was first employed in the Prussian service in 1840. In 1841 he established a large factory, which between that time and 1863 produced 300,000 needle guns, and employed in 1865 about 1,500 persons. He was ennobled in 1864.

**DRIFT.** See DILUVIUM.

**DRILL**, in mechanics. See BORING.

**DRILL**, in zoölogy. See BABOON.

**DROGHEDA**, a town and port of Ireland, in the province of Leinster, and counties Meath and Louth, on the river Boyne, 4 m. from its mouth, and 26 m. N. of Dublin, with which it is connected by rail; pop. in 1871, 16,135. It was for a long time strongly fortified, and from an early period till about the close of the 17th century was regarded by the English as a post of great importance. It was for three centuries the principal rendezvous of the numerous troops marched against the refractory and rebellious chieftains of Ulster and Leinster. It was gallantly defended in the civil war against a large force under Sir Phelim O'Neill (1641-'2). It 1649 it was stormed by Cromwell, and on account of the carnage then inflicted the name of the protector is still abhorred by the inhabitants. In 1690 the town held out against the troops of William III. until after the battle of the Boyne, fought two miles from its walls, which is commemorated by an obelisk 150 feet high raised upon the spot where Schomberg fell. Few of the ancient fortifications remain. The only perfect specimen is the St. Lawrence gate, consisting of two lofty round towers with the low gateway between. The Magdalen's steeple, a square structure of elegant proportions, is all that remains of a Dominican convent founded in 1224. Among

many other ruins are those of a Carmelite convent, and of a hospital of the knights of St. John of Jerusalem. The town is now the seat of extensive cotton and linen manufac-



Gate of St. Lawrence.

rics, tanneries, and breweries, and has some ship building and considerable trade in corn and cattle. Its harbor has been much improved within a few years, and vessels of 250 tons can discharge at the quay. Steamers ply constantly between Drogheda and Liverpool.

**DROHOBYCZ**, a town of Austria, in Galicia, situated on a small tributary of the Dniester, 18 m. S. E. of Sambor; pop. in 1870, 16,884. Its Catholic church is the handsomest religious edifice in Galicia. It has important salt works and manufactories of pottery, leather, and linens.

**DROITWICH**, a parliamentary and municipal borough of Worcestershire, England, 6 m. N. E. of Worcester and 132 m. by rail N. W. of London; pop. of the parliamentary borough in 1871, 9,510; of the municipal, 3,504. It is lighted with gas, and has a lunatic asylum and a hospital. Its chief trade is in salt, for the production of which it is famous, and which has been made there for more than 1,000 years. It is obtained from brine springs which rise near the centre of the town from a depth of 200 ft. The brine contains about 33 per cent. of salt, and used as baths has proved highly beneficial in cases of rheumatism and gout. About 100,000 tons of salt are made annually, which is shipped mostly by a canal connecting with the river Severn, capable of admitting vessels of 60 tons. The brine springs were anciently called *vyches* (Saxon), hence the name of the town, the prefix *droit* being supposed to refer to some right or privilege of the early inhabitants to manufacture salt. The town is supposed to have been the Roman *Salinæ*.

**DRÔME**, a S. E. department of France, formed from parts of Dauphiny and Provence, bordering on the departments of Isère, Hautes-Alpes, Basses-Alpes, Vaucluse, and Ardèche, from the

last of which it is separated by the Rhône; area, about 2,500 sq. m.; pop. in 1872, 320,417. It derives its name from the river Drôme, which crosses it from E. to W., dividing it into two nearly equal parts. It is drained also by the Isère and numerous other streams, all, like the Drôme, affluents of the Rhône. The surface is much broken by mountains, particularly in the east, where the spurs of the Alps rise to an average height of 4,000 to 5,000 ft. These furnish excellent pasturage, and are browsed in the summer

and autumn by large flocks of sheep, many of which are driven thither from neighboring departments. Fir, oak, and beech trees grow on the summits, and on the lower hills are plantations of chestnuts and walnuts, from the latter of which oil is made. The forests abound in game and the lakes and streams in fish. A large part of the soil is thin and sandy, and not enough grain is raised for home consumption; but the vine, olive, mulberry, and other fruits are raised in large quantities. Some of the vineyards are famous, among them

L'Hermitage near Tain, on the Rhône, and those of Châteauneuf, Douzère, and Montélimart. The making of wine and the production of silk are the chief industries. There are manufactures also of porcelain, beet-root sugar, coarse woollens, hosiery, serge, linens, gloves, leather and morocco, paper, and bricks. Mines of iron, lead, and coal are worked, and gypsum and marble abound. The department is divided into the arrondissements of Valence, Die, Montélimart, and Nyons. Capital, Valence.

**DROMEDARY.** See CAMEL.

**DRONTHEIM** (Danish, *Thronthjem*; locally, *Drontjem*). **I.** A province (diocese) of Norway, bordering on Sweden and the North sea; area, 19,550 sq. m.; pop. in 1865, 256,529. It is mountainous, and much of it well wooded. The coasts are indented by numerous bays, the most important of which is the Drontheim fiord, running 60 m. inland in an E. and N. E. direction, but describing with its windings a curve of 90 m.; and the surface is dotted over with lakes. The inhabitants are engaged chiefly in fishing, cattle raising, iron mining, and to some extent in agriculture. Fruit, hops, flax, and hemp are the principal crops; but little grain is raised. **II.** A town, the capital of the province, and the third of the cities of Norway in importance and population, in lat. 63° 25' N., and lon. 10° 23' E., on a small gulf near the outlet of the river Nid, by which river and the sea it is almost

entirely surrounded, 233 m. N. of Christiania; pop. in 1870, 20,858. The most interesting edifice is the cathedral of St. Olaf, founded in the 11th century; the little of the original building that remains and forms part of the present cathedral is sufficient to show that it was a magnificent Gothic structure. The harbor is not deep, and is frequented only by small vessels. Its trade consists chiefly in exports of masts, copper and iron, goat skins, and dried and salted fish. It has a public



Cathedral of Drontheim.

library, a museum, and a society of arts and sciences, founded in 1760. On a rock in the midst of the harbor is the fortress of Munkholm, anciently an abbey, then a state prison, and now the chief fortification of the city on the sea side. On the land side Drontheim is commanded by a succession of picturesque heights. It was founded in 997, and for a long time was the residence of the kings of Norway, who were consecrated and crowned in its cathedral; and the kings of Sweden are still crowned there as kings of Norway. As it was formerly built only of wood, it has been several times almost entirely destroyed by fire.

**DROPSY** (originally *hydropsy*; Gr. *ἵδωρ*, water, and *ὄψις*, the face or appearance), a morbid collection of fluid in one or more of the serous cavities within the body, or in the areolar tissue beneath the skin, and in other situations. A dropsical accumulation is to be distinguished from the effusion of liquid which takes place in certain inflammatory diseases, pleurisy, peritonitis, pericarditis, &c. In these diseases the effusion is due to inflammation, whereas in dropsy transudation takes place without the parts where it occurs being inflamed. Moreover, the liquid which is the result of inflammation is either purulent or accompanied by coagulable lymph or fibrinous exudation. Dropsy may be local or general. It is local when the effusion of liquid is con-

fined to a single serous cavity, or to the areolar tissue within a limited space. In medical nomenclature dropsical affections in the different serous cavities are expressed by the prefix hydro in connection with the names of the serous structures. Thus, hydrothorax is the name for a dropsical effusion into the pleural cavity; and so hydropericardium, hydrocephalus, hydroperitoneum, &c., denote dropsy in the several situations which these names express. An effusion into the areolar tissue is called œdema; thus, œdema of the face, of the limbs, and of different internal organs. An exception to the usual significance of the name œdema is afforded by the affection known as œdema of the lungs; the dropsical effusion in this affection taking place, not into the areolar tissue, but into the air cells. • Dropsy is said to be general when effusion into the areolar tissue beneath the skin exists more or less over the whole body, accompanied with effusion into certain serous cavities, especially the pleural and the peritoneal. The name anasarca is used to denote general dropsy. In all cases dropsy is a symptom of disease seated elsewhere than in the situations where the dropsical effusion takes place. Thus, the local dropsy of most frequent occurrence is hydroperitoneum, called also ascites and hydrops abdominalis. Here, the effusion into the peritoneal cavity is generally symptomatic of disease of the liver, and especially of that form of disease, caused by spirit drinking, called cirrhosis of the liver, other names being gin liver, whiskey liver, and hobbled liver. The explanation of the dropsy in these cases is as follows: The veins from the organs within the abdomen unite to form the vein called the *vena portæ*, which passes into the liver. All the venous blood contained in the other abdominal viscera circulates in the liver, and passes thence to the heart to enter the general circulation. In cirrhosis of the liver, the circulation within this organ is obstructed, and venous congestion of the other abdominal organs results. Serous transudation into the peritoneal cavity is the effect of this congestion (portal congestion, as it is called). Sometimes a tumor within the abdomen is so situated as to press upon the *vena portæ* and occasion an obstruction to the passage of blood through this vessel, and in this way hydroperitoneum may be produced. In other local dropsies the rationale, in general, is similar; that is, the dropsical effusion is the result mainly of the hydraulic pressure due to a persistent over-accumulation of blood in the veins which are in relation to the part where the dropsy takes place. The same principle is chiefly concerned in the causation of general dropsy in a certain proportion of cases. The dropsy in these cases is due to an obstruction affecting the venous system throughout the body. In the great majority of these cases the obstruction is incident to diseases of the heart, and it is customary therefore to distinguish them as cases of cardiac dropsy. Cer-

tain organic affections of the heart, before they end fatally, give rise to more or less general dropsy or anasarca. In other cases general dropsy depends in a great measure on a morbid attenuation of the blood, which becomes watery, and hence the serous portion tends to transude through the pores of the vessels. This is the explanation, at least in great part, of the occurrence of general dropsy in cases of certain affections of the kidneys included under the name Bright's disease. The blood becomes watery, or hydræmic, in consequence of the constant elimination of albumen by the kidneys. The dropsy in these cases is distinguished as renal dropsy. In by far the larger number of cases of general dropsy it is either cardiac or renal. Not infrequently, however, there is a coexistence of disease of the heart and disease of the kidneys, and then venous obstruction and watery blood may concur in producing the general dropsy. When not dependent on disease of the heart or the kidneys, general dropsy is a symptom of hydræmia, together with feebleness of the circulation. It occurs sometimes as a sequel of prolonged intermittent fever.—The treatment of dropsy, either local or general, involves measures indicated by the diseases which stand in a causative relation to the dropsy; for example, the disease of the liver in cases of hydroperitoneum, and of the heart or of the kidneys in cases of cardiac or renal dropsy. Exclusive of these indications, it is often an object of treatment to effect either removal or diminution of the dropsical accumulation. Remedies which produce watery evacuations from the bowels, and those which increase the secretion of urine, are chiefly relied upon for the accomplishment of the object just stated. This is also sometimes promoted by producing free perspiration. The employment of the cathartics called hydrogogues, and of diuretics, is to be governed by an appreciation of the diseases coexisting with the dropsy, by the condition of the patient, and by the varied circumstances pertaining to individual cases. The liquid in serous cavities may be removed by a puncture or an incision, an operation called paracentesis, or vulgarly tapping. In some cases of dropsy of the chest paracentesis is resorted to (called also thoracentesis), but this operation is much oftener employed in pleurisy with effusion than in cases of dropsy. Tapping of the abdomen (*paracentesis abdominalis*) is often employed, and is in many cases useful, not only by relieving suffering but promoting recovery. In cases of general œdema, or anasarca, if the effusion be very large, great relief is sometimes obtained by minute punctures of the lower limbs, through which the serum drains away in abundance.

**DROSTE, Annette Elisabeth**, Baroness Hülshoff, a German lyrical poetess, born near Münster, Jan. 12, 1798, died in a villa near the lake of Constance, May 24, 1848. Her health was bad, and her whole life was devoted to religion, study, and poetry. She left many compositions,



of which *Das geistliche Jahr, nebst einem Anhang religiöser Gedichte*, appeared in 1852.

**DROUET, Jean Baptiste**, a French revolutionist, born at Sainte-Menehould, in Champagne, Jan. 8, 1763, died in Mâcon, April 11, 1824. After serving seven years as a common soldier, he returned to his native town, where he assisted his father, who was at the head of the post office. In the evening of June 21, 1791, the royal family, on their flight to the frontier, stopped at the town to change horses, when Jean Baptiste identified Louis XVI. and Marie Antoinette, and caused them to be arrested. For this the national assembly voted him 30,000 francs, which he is believed to have refused; and in September, 1792, he was chosen member of the convention by his native department of Marne. Here he became one of the most violent of the terrorists. He voted for the immediate death of the king, and on July 20, 1793, he proposed a wholesale butchery of the English residents of France. In September he was sent on a mission to the army of the north, fell into the hands of the enemy, and was sent to the fortress of Spielberg. This added to his popularity, and on his return to Paris in December, 1795, he was received with great enthusiasm, and appointed secretary of the council of 500. He joined Babeuf's conspiracy and was imprisoned, but made his escape, and took refuge in Switzerland, and afterward in the Canary islands. Here he aided the inhabitants in repelling the attack of Nelson on Teneriffe in 1797. Being acquitted in the Babeuf trial, he returned to Paris and resumed his old position. After the advent of Napoleon he suddenly and completely dropped his republican convictions, became a sub-prefect, and fought in 1814 against the allies. During the hundred days he represented his department in the chamber of deputies, but under the restoration he was expelled from France as one of the regicides. He passed the last years of his life at Mâcon under the fictitious name of Merger, and was only identified after his death.

**DROUET D'ERLON, Jean Baptiste**, count, a French general, born in Rheims, July 29, 1765, died in Paris, Jan. 25, 1844. He entered the army as a private in 1782, was discharged in 1787, reentered it as a volunteer in 1792, became aide-de-camp to Gen. Lefèvre, was present at the sieges of Valenciennes, Quesnoy, and Condé, and in 1797 at the investment of Ehrenbreitstein. He was made a general of brigade in 1799, and fought in that year in Switzerland, at Schaffhausen, Zürich, and Constance. He also served at Ulm, Hohenlinden, and Steyer, and was made general of division in August, 1800. The success of the French arms at Jena was largely due to the skilful manœuvres by which he defeated the Prussian column under Von Trescott. He further distinguished himself at the siege of Dantzic and the battles of Mohrungen and Friedland, and in 1807 received the title of count d'Erlon and a gift of 25,000 francs. He

subsequently fought with distinction in the Tyrol and in the Peninsular war. After the first restoration he was given the command of the 16th division of the army, and received other honors; but in March, 1815, he was arrested for complicity in a conspiracy against Louis XVIII., and thrown into prison. The return of Napoleon from Elba soon gave him his liberty, and he resumed his command. Napoleon made him a peer of France in June, 1815, and treated him with great favor until the battle of Waterloo. Here his apparent inaction, which he afterward sought to prove was the effect of contradictory orders, caused the emperor to reproach him bitterly. He resided at Munich ten years, and established a brewery there. When Charles X. in 1825 granted amnesty to those who had fought for the reestablishment of the empire, he returned to France. After the revolution of July, 1830, he became commander of the 12th military division, and in 1834 he was appointed governor general of the French possessions in Africa. In 1843 he was made a marshal of France.

**DROUYN DE LHUYS, Édouard**, a French diplomatist, born in Paris, Nov. 19, 1805. He studied law, was successively attached to the embassies at Madrid and the Hague, and in 1840 became head of the commercial bureau in the ministry of foreign affairs. In 1842 he took his seat as an opposition member of the chamber of deputies, was dismissed from office, and became one of the most active opponents of Guizot and a prominent orator at the reform banquets. After the revolution of 1848 he was elected to the constituent assembly, and became president of the committee on foreign affairs. He was a leading supporter of Louis Napoleon, who called him into his first ministry. In June, 1849, he was appointed ambassador to England. He adhered to Louis Napoleon after the *coup d'état* of Dec. 2, and under the empire was minister of foreign affairs. In the negotiations preceding the Crimean war, at the conference of Vienna, he endeavored to prevent it, and resigned on account of his failure. In 1856 the emperor sent a message to the senate reflecting upon its inactivity, whereupon Drouyn de Lhuys resigned his seat in the senate, and accepted the presidency of the council of administration of the eastern railways. He again became minister of foreign affairs in 1862, and as such urged the cabinets of Prussia and England to propose a six months' truce between the contending parties in the United States, but without result. On Sept. 15, 1864, he signed the convention with Italy concerning the recall of the French troops from Rome. In 1866 he desired France to intervene between Prussia and Austria, but his views not prevailing, he resigned Sept. 1. On the downfall of the empire he went to the island of Jersey.

**DROWNING.** The specific gravity of the human body is very little greater than that of water; for though the muscles and the bones are heavier (the one being 1.085, the other

2·01), the fat (0·92) is specifically lighter, and the air within the thorax tends to establish an equilibrium. Owing to this, a very slight exertion enables one to keep himself at the surface of the water; but any part of the person, as an arm, raised out of the fluid, acts like a weight imposed upon the rest of the body, and thus inexperienced persons are often drowned by their own struggles. Death takes place from asphyxia; the blood in the lungs being unchanged by the action of air, the circulation through these organs is obstructed, and the blood becomes charged with carbonic acid; insensibility is rapidly induced, and death takes place, frequently preceded by convulsive movements. The period during which the submersion may continue without death varies in different persons. (See DIVING.) In some instances bodies submerged but a minute, in despite of all attempts at restoration, have been found completely lifeless, while many cases are on record in which recovery has taken place after a submersion of five minutes. In the "London Medical Gazette," vol. xxxi., a case is given of recovery after 14 minutes' submersion; the time here was calculated, but the circumstances render the calculation exceedingly probable. The explanation of recovery after prolonged submersion has been sought in the occurrence of fainting at the moment of the fall, and it is certain that during syncope the demand for air is very much diminished.—When the body is recovered a few hours after drowning, the skin is cold and pale, presenting sometimes patches of livid discoloration; the expression is placid, the eyes half open, the pupils dilated, the tongue swollen and pressed forward, and the lips and nostrils covered by a mucous froth; the fingers are sometimes found torn and abraded, and the hand grasping gravel or other substances which have been seized in a convulsive struggle at the bottom. Internally the body presents few appearances which are characteristic of the mode of death; of these the presence of a mucous froth, sometimes stained with blood, and perhaps of a little water in the trachea, and of water in the stomach, are most noteworthy. The water contained in the stomach appears to be swallowed previous to death; after death the apposition of the sides of the œsophagus prevents the entrance of water into the stomach. When the body is recovered after a short immersion in the water, efforts for resuscitation should be made immediately, and perseveringly continued until recovery takes place or the case is evidently hopeless. In a case related by Mr. Bloomfield  $1\frac{1}{2}$  hour elapsed before there was any appearance of returning animation; and in one by Dr. Douglas ("Medical Gazette," vol. xxxi., p. 449), success was met with only after  $8\frac{1}{2}$  hours. The plan proposed by Dr. Marshall Hall in 1855 is based on physiological principles, and has been found eminently successful in practice. His rules are as follows:

1. Treat the patient instantly, on the spot, in the open air, freely exposing the face, neck, and chest to the breeze, except in very severe weather.
2. Send with all speed for medical aid and for articles of clothing, blankets, &c.
- I. *To clear the throat.* 3. Place the patient gently on the face, with one wrist under the forehead. All fluids, and the tongue itself, then fall forward, and leave the entrance into the windpipe free.
- II. *To excite respiration.* 4. Turn the patient slightly on his side; apply snuff or other irritant to the nostrils; and dash cold water on the face, previously rubbed briskly until it is warm. If there be no success, lose no time, but apply the third rule.
- III. *To imitate respiration.* 5. Replace the patient on his face. 6. Turn the body gently but completely on the side, and a little beyond, and then on the face, alternately, repeating these measures deliberately, efficiently, and perseveringly, 15 times in the minute only. (This number of thoracic movements per minute agrees with the natural order of respiratory thoracic dilatations and contractions, corresponding with a slow movement of the heart, averaging something less than 60 pulsations per minute, and therefore merits due attention.) The rationale of the operation is this: When the patient rises on the thorax this cavity is compressed by the weight of the body, and expiration is promoted; when he is turned on the side, this pressure is removed, and inspiration is facilitated.
7. When the prone position is resumed, make equal but efficient pressure along the spine, removing it immediately before rotation on the side. (The first measure augments expiration, the second commences inspiration.)
- IV. *To induce circulation and warmth.* 8. Continuing these measures, rub the limbs upward, with firm pressure and with energy, using handkerchiefs, &c. 9. Replace the patient's wet clothing by such other covering as can be instantly procured, each bystander supplying a coat or waistcoat. Meanwhile, and from time to time, proceed to the fifth rule.
- V. *To excite inspiration.* 10. Let the surface of the body be slapped briskly with the hand; or, 11. Let cold water be dashed briskly on the surface, previously rubbed dry and warm.

**DROYSEN, Johann Gustav**, a German historian, born at Treptow, Pomerania, July 6, 1808. He studied at Stettin and at Berlin, and between 1829 and 1840 was a teacher at a gymnasium in the latter city, and private tutor and professor at the university. In 1840 he went to Kiel as professor of history, and during a residence of ten years was an active partisan of the duchies of Schleswig and Holstein in the controversy with Denmark. He was the author of the "Kiel address" of 1844, and in 1846 took part in the preparation of the protest signed by nine professors of the university. On the establishment of the provisional government in Kiel in 1848, he was sent as a plenipotentiary to the diet at Frankfort, where he advocated the rights of the duchies. Subsequently he was a member of the Frankfort parliament. In 1851 he was called to Jena as professor of history, and in 1859 to the same chair at Berlin. Among his earlier works are translations of Æschylus and Aristophanes, a history of Alexander the Great (1833), and a history of Hellenism (2 vols., Hamburg, 1836-'43). Turning his attention to modern history, he published *Vorlesungen über die Geschichte der Freiheitskriege* (Kiel, 1846); *Leben des Feldmarschalls Grafen York von Wartenburg* (Berlin, 1851); and *Geschichte der preussischen Politik* (10 vols., Berlin, 1855-'70).

**DROZ, François Xavier Joseph**, a French author, born in Besançon, Oct. 31, 1773, died Nov. 4, 1850. In 1803 he removed to Paris, where he became acquainted with the prominent philosophers of the day. After a variety of smaller works which failed to attract attention, he published in 1806 an *Essai sur l'art d'être heureux*, which passed through numer-

ous editions, and was translated into English. In 1812 he published *Éloge de Montaigne*, in 1815 *Essai sur le beau dans les arts*, and in 1823 *De la philosophie morale, ou des différents systèmes sur la science de la vie*, which received the Monthyon prize, and paved the way to his admission to the French academy, Larmartine being his competitor. In 1825 he wrote a book on the application of morals to philosophy and politics. He is also the author of an essay on political economy, and of a work on Christianity, which derives interest from the personal religious experiences added to the book, under the title of *Aveux d'un philosophe chrétien*, in which the author abandons his early theology and returns to the doctrines of the church of Rome. His most important work is his *Histoire du règne de Louis XVI.* (3 vols., Paris, 1839-'42), with an introduction on the history of France from Louis XIV.

**DROZ, Gustave**, a French author, born in Paris, June 9, 1832. He studied at the colleges of Stanislas and Henry IV., and received subsequently instruction in drawing and painting at the school of fine arts. In 1864 he joined Marcellin in editing the journal *La vie parisienne*, and published in it a series of works, under the pseudonyme of Gustave Z., which passed through 20 editions within two years, as separate volumes entitled *Monsieur, Madame et Bébé; Entre nous; and Le cahier bleu de Mlle. Cibot*. His style presents a strange mixture of malice, skepticism, and mirth, though he describes the miseries and sorrows of life with great delicacy and deep feeling. He has since published *Autour d'une source* (1869) and *Un paquet de lettres* (1871). His works have been translated into English.

**DROZ. I. Pierre Jaquet**, a Swiss mechanic, born at La Chaux-de-Fond, July 28, 1721, died at Bienne, in the canton of Bern, Nov. 28, 1790. In the divinity school of Basel he prepared for the church, but on his return home his attention became directed to the manufacture of watches and clocks, for which his native town is celebrated. He eventually perfected the different parts of clockwork, and supplied common timepieces with a musical machinery which imitated a chime of bells and the sounds of the flute. He made many experiments for the purpose of effecting perpetual motion. His most ingenious contrivance was a pendulum composed of two metals of unequal dilatibility to counteract the effects of heat and cold. This was purchased by the king of Spain, who bestowed a pension upon the inventor. His most celebrated production was a writing automaton, which moved its fingers and hands, and formed letters. At the time of his death he was engaged upon the fabrication of a new astronomical clock. **II. Henri Louis Jaquet**, son of the preceding, born Oct. 13, 1752, died in Naples, Nov. 18, 1791. In 1774 he removed to Paris, and became celebrated for his mechanical productions, especially an automaton representing a young

lady playing on the harpischord, following the music with her eyes and the movements of her hands, and, when done playing, rising and bowing to the audience. The most famous specimen of his inventive genius in this respect was a pair of artificial hands which he devised for La Raynière, who had lost his hands during a hunting expedition.

**DRUIDS**, an order of priests which in ancient times existed among certain branches of the Celtic race. The name has been variously deduced from the Saxon *dry*, a magician; from the Greek *δρῦς*, and the Celtic *deru*, an oak; from the Irish *drui* or *draui*, a sacred person, &c.; but the most probable derivation seems to be that given by the abbé Pierre de Chiniac, who refers it to the old Celtic compound *derouyd*, from *De*, God, and *rouyd*, speaking, a participle of the verb *rouyddim*, to speak. The origin of the institution is no clearer than



A Druid Priest.

the etymology of the name. The druids did not allow their tenets and history to be committed to writing, and the ancient Greek and Roman authors describe them only in the vaguest language. It seems to be generally conceded that they were of eastern origin, because of the many and striking analogies between what we are told of their belief and practices, and what we know to be characteristic of the oriental nations. At the time when this mysterious order became known more clearly to history, *i. e.*, in the first century before and after Christ, they inhabited chiefly Gaul and the islands of Britain. In Gaul their principal seats were in the west and centre, in modern Brittany and along the Loire, while beyond the channel they were found in Wales and Ireland, and afterward in the island of Mona or Anglesea. According to

some writers Brittany was their cradle; but the Welsh traditions relate that they entered Gaul from the remote east at the same time with that branch of the Celtic race which is denominated the Kymric or Cymraeg. At least it is evident that they did not prevail among the Belgic branches of the people of Gaul at the north, nor yet among the Aquitanian or Basque branches at the south. Their capital in Gaul was in the territory of a tribe called the Carnutes, corresponding nearly to the province of Orléanais. Julius Cæsar is the ancient writer who has given the clearest account of the druids, and Godfrey Higgins, in his "Celtic Druids," the modern who has most elaborately investigated their faith; but the Welsh triads are regarded by many as the most authentic sources of information in regard to them. Their characteristics, in the view of Mr. Higgins, consisted in the adoration of one Supreme Being, in the belief of the immortality of the soul and a future state of rewards and punishments, taking the form of a species of metempsychosis, in the use of circular temples open at the top, in the worship of fire as the emblem of the sun, in the celebration of the great Tauric festival (when the sun entered Taurus), and in the knowledge of an alphabet of 17 letters, though their instructions were always oral. If they acknowledged but one supreme God, they admitted other inferior deities, such as Hesus, Tarann, Belen, &c., to whom they paid a qualified worship. In their sacrifices to these the bodies of human victims often smoked on the same altars with the carcasses of beasts. Their objects were apparently moral, for they professed "to reform morals, to secure peace, and to encourage goodness;" yet with these high aims they connected pernicious superstitions and pretences to a magical knowledge. They assumed, says Cæsar, to discourse of the hidden nature of things, of the extent of the universe and of the earth, of the forms and movements of the stars, and of the power and rule of the gods. On all these subjects their instructions were conveyed orally, and by means of verses, which required a novitiate of 20 years before they could be well committed to memory. The triads of the Welsh bards are supposed to be specimens of this species of verse. They undoubtedly possessed some knowledge of the movements of the heavenly bodies, beyond what simply pertained to the regulation of their religious festivals, inasmuch as they composed the year by lunations, which supposes an acquaintance also with the solar year. Various relics found in Ireland among the druidical remains, thought to be astronomical instruments designed to show the phases of the moon, are described by Sir William Betham in the "Transactions of the Royal Irish Academy." At the same time not a little of astrology, divination, and magic was mixed up with their purer science. In their doctrine of medicine particularly there was far more of superstition than of knowl-

edge. To a great many plants they attributed a mystic sacred character; and most of all to the mistletoe, which they esteemed an antidote to all poisons and a cure for all diseases. It was gathered at certain seasons, with the most formal and pompous ceremonies. As soon as it was discovered, twining the no less sacred oak, the druids collected in crowds about the tree, a banquet and a sacrifice were prepared, a priest in white vestments cut the twig with a golden sickle, two other white-robed priests caught it in a white cloak, two milk-white heifers were instantly offered up, and the rest of the day was spent in rejoicing. Under similar mystic faith they plucked the *samolus*, or marshwort, with the left hand, fasting, and without looking at it; and the *helago*, or hedge hyssop, after ablutions, or offerings of bread and wine, barefooted, and without a knife. The vervain likewise demanded distinct ceremonials. All these plants were regarded as powerful prophylactics and remedies, not only in respect to physical diseases, but to the dark workings of evil. They were carried about as charms, as well as amber beads, which the druids manufactured for warriors in battle, and which are still found in their tombs. A more potent talisman was the serpent's egg, which, according to Pliny, oozed out of the mouths of serpents when knotted together, and which they supported in the air by their hissings. That was the moment to seize it; and he who attempted to do so must suddenly dart from his hiding place, catch it in a napkin, and mounting a horse gallop off at full speed, to escape the pursuing serpents, until he had put a river between him and them. Among the druids, as among the Romans, auguries of the future were made from the flight of birds, and from an inspection of the entrails of sacrificed animals. Their profounder ceremonies, performed in the depths of the oak forests or of secluded caves, are known to us only through the vaguest traditions, and in the stupendous but dilapidated stone monuments which strew the surface of France and Britain.—The druids were organized into a regular hierarchy, consisting of a triad, like almost everything else among them, viz.: the bards, the vates or prophets, and the priests proper. The bards were poets not only of a religious but of a martial and satirical class. (See BARD.) The vates were the diviners or revealers of the future, who were charged with the conduct of sacrifices and other external ceremonies, and who, mingling in almost every event and relation of common life, stood as mediators or interpreters between the people and the more mysterious hierophants. These were the druids proper, or the priests, who dwelt in the depths of the oak forests, preserving the mystic doctrines of the faith, and consulting more directly the secret will of the divinity. They were the teachers of the youth, who resorted to them in great numbers; and they also exercised the judicial

function. All men, whether in a public or private capacity, had to submit to their decisions, for the recalcitrant was condemned to excommunication, which rendered him an outcast and an outlaw. Over the community or college of druids an arch-druid presided, whose authority was supreme and irrevocable, although his office was elective. The election was made by the suffrages of the whole body, but sometimes, in the rivalry of factions, led to serious conflicts of arms. At a fixed period every year they assembled at a consecrated spot in the territory of the Carnutes, which passed for the centre of Gaul, whither all resorted who had disputes to settle or decrees to solicit. The entire priesthood were exempted from all taxation or imposts, and from every burden of war or peace.—Affiliated to these three orders, without sharing their prerogatives, were prophetesses, or sorceresses, apparently divided into three orders also, according to their degrees of sanctity. Their rules were whimsical and contradictory, but their influence over the fears of the people was powerful. One branch of them could declare the secrets of futurity only to those who had polluted them; another was devoted to perpetual virginity; a third to long periods of celibacy, or they were allowed to visit their husbands but once a year; while others had to assist at nocturnal rites with their naked bodies painted black, their hair dishevelled, and abandoning themselves to transports of fury. Their favorite resort was the island of Sena, where the nine Senes dwelt, and the nameless islet opposite the mouth of the Loire, where once every year, between sunrise and sunset, they pulled down and rebuilt the roof of their temple; but if any one by chance let fall a particle of the sacred materials, she was torn to pieces, amid frantic dances, in which the Greeks saw the rites of their own Bacchantes, or the orgies of Samothrace.—The druids attained to an almost absolute rule, which was in many respects beneficial, but it also inevitably degenerated into tyranny. They sooner or later, therefore, aroused the jealousy of another order in society, which Cæsar designates the *equites* or warriors, who had taken the lead in the political conduct and constitution of the tribes. It is supposed that these gradually overthrew the power of the druids in Gaul. When that country was subdued by the Romans, the druidical religion gradually retired before the classic heathenism, and withdrew, at first into Armorica, and then into Britain, where in the time of Nero it was assaulted and mostly suppressed. It lingered as a public worship longest in the island of Anglesea, whence it was finally driven out by the Romans with great fierceness. As a private superstition it continued to hold sway for many years thereafter over the minds of the Celtic tribes and their descendants. The only modern remains of druidism are the immense structures of stone, the menhirs, cromlechs, dolmens, and

avenues, which are found in the immense ruins at Stonehenge, Avebury, and Carnac, as well as in many smaller forms throughout Great Britain and western France.—See Barth, *Ueber die Druiden der Celten* (1826); G. Higgins, "Celtic Druids" (1827); and the first volume of Henri Martin's *Histoire de France* (1833).

**DRUM** (Dan. *trom*; Ger. *Trommel*), in music, a hollow cylinder of thin wood or brass, covered at each end with vellum or parchment, the tension of which is regulated by small cords or braces on the outer side of the instrument acted upon by sliding knots of leather. The common drum is suspended at the side of the drummer, whence it is called the side drum, and is beaten upon at one end with sticks. An instrument similar in shape, but on a much larger scale, called the base drum, is beaten at both ends with drumsticks having leather pads on the knobs. Both kinds are highly effective in military bands. Another species, called the kettle drum, consists of a thin copper basin, nearly hemispherical, the parchment covering of which is held by an iron rim, and tightened or relaxed by screws. Kettle drums are always in pairs, one instrument being tuned to the key note, and the other to the fifth of the key. They are generally supported on iron tripods. Instruments of percussion of the drum species have been familiar in the East from remote ages, and among savage races in all parts of the world are used in the celebration of religious rites as well as for the performance of music. They were common among the Egyptians, chiefly for military music, as early as 1600 B. C., some being long cylinders, similar to the tom-toms of India, which were beaten with the hand, while others were of a barrel shape and were beaten with sticks. Among the Greeks and Romans the drum, called the *tympanum*, had the form of the modern kettle drum or of the tamborine. The drum was probably introduced into Europe by the Saracens and Moors, by whom it was called the *tumbur*, whence the Spanish *tambor* and the French *tambour*; and in the first half of the 14th century it was generally adopted for military music.

**DRUMMOND, Thomas**, a British naval officer and inventor, born in Edinburgh in October, 1797, died in Dublin, April 15, 1840. While a cadet at Woolwich he displayed unusual mathematical ability, and attracted considerable attention by rejecting as unsatisfactory a standard demonstration in conic sections, and supplying a new and original one, which was adopted in future text books. In 1820 he was employed in the trigonometrical survey of the United Kingdom. He had given considerable attention to chemistry, and conceived the idea that the incandescence of lime might be put to use for illuminating distant stations in the survey, as a substitute for the argand lamp. In 1824 he was transferred to the survey of Ireland, in which some improved method of illumination was still more a necessity, and there constructed his lamp. Its first trial was

at Slieve Snaught, Donegal, and it was distinctly seen by the engineers at Devis mountain, 66 miles distant. Subsequently it was said to have been visible at a distance of 112 miles. Drummond described his invention in the "Philosophical Transactions" for 1826. When quicklime is subjected to intense heat, such as is produced by the oxyhydrogen blow-pipe, the light emitted is exceedingly powerful and dazzling; the lime itself is slowly volatilized, and the surface around is covered with its sublimate. Drummond placed the light thus produced in the focus of a parabolic mirror, which reflects the rays in parallel lines, thus directing the entire light toward a single point. Many experiments have been made to adapt the Drummond light to lighthouses; but the deficiency of divergence in the rays, and the difficulty of maintaining a regular supply of gases for the blowpipe, have thus far proved insurmountable. It has been applied to the gas microscope, in which it gives the prismatic colors almost as bright as in the solar spectrum. In 1825 Drummond invented a heliostat, which is still employed in the government survey of Great Britain. He made a large collection of scientific instruments, and carried on extensive experiments for their improvement; but the entire collection and the observatory that contained it were destroyed by a storm in a single night. In 1835 he was appointed under secretary for Ireland. In 1836 he was placed at the head of a commission to plan a railway system for Ireland, and his scheme has been substantially followed. The oft quoted words, "Property has its duties as well as its rights," are from a letter which he wrote to the magistrates of Tipperary in 1838. He was a favorite with the Irish people, who erected a statue to his memory in the royal exchange of Dublin. A memoir of his professional life, by Capt. Laron, was published in 1841, in the 4th volume of "Papers on Subjects connected with the Duties of the Corps of Royal Engineers."

**DRUMMOND, William**, a Scottish poet, born at Hawthornden, Edinburghshire, Dec. 13, 1585, died Dec. 4, 1649. He spent about eight years on the continent of Europe engaged in study, travel, and the collection of books; but passed most of the remainder of his life on his estate at Hawthornden, devoting himself to literature. He wrote a history of Scotland from 1423 to 1542; but the work is of little value, and he is chiefly remembered for his poetry and for his "Notes of Ben. Jonson's Conversations with William Drummond of Hawthornden, January, 1619." His versification sometimes bears a striking resemblance to that of some of Milton's poems. His sonnets, which form a considerable part of his works, are especially elegant. An edition of his poems, with a life by Peter Cunningham, was published at Edinburgh in 1852.

**DRUMMOND, Sir William**, a British author and diplomatist, born in Scotland about 1760, died in Rome, March 29, 1828. In 1794 he

published "A Review of the Government of Sparta and Athens," and in the following year was elected to parliament. He sat also in the parliaments of 1796 and 1801, and was sent on diplomatic missions to Naples and Constantinople. He published a number of works, among which are: "Academical Questions" (4to, 1805), containing an attack on all kinds of dogmatism, embracing an exhibition of insoluble problems, and tending to show the weakness of the human intellect; and "Origines, or Remarks on the Origin of several Empires, States, and Cities" (4 vols. 8vo, London, 1824-'9). A work written by him, printed for private distribution, and entitled "The Œdipus Judaicus" (1811), brought upon its author much censure and criticism, because of its attempt to explain away some of the narratives of the Old Testament as astronomical allegories. He was an accomplished scholar, and made an excellent translation of the satires of Persius.

**DRUSES, or Druzes**, a race and religious sect of Syria, chiefly in the southern ranges of Lebanon and Anti-Libanus. Their name is derived from Derazi or Durzi, who, according to the Arabic historian Makrizi, appeared in Cairo A. D. 1019, as a missionary of the Batonian sect, an offshoot from the Moslem stock. The Druses regard him as a heretical pupil of Hamza, the Messiah of their system, and look upon the title which has been fastened upon them as a stigma, the only name they acknowledge being that of Muahids or Unitarians. The proper era of the Druses begins in 1020, when Hamza, a wandering fanatic, persuaded Hakem, the Fatimite caliph of Egypt, to declare himself a manifestation of God. The caliph was assassinated the next year, and Hamza, retiring into Syria, continued to propagate the new faith among the mountain tribes. He and one of his followers, Moktana Boha ed-Din, committed their doctrines to writing, and enjoined the strictest secrecy as to their nature. No member of another sect and no uninitiated Druse was to be permitted to see the sacred writings, and no revelation is to be made until the second advent of the lord Hakem and Hamza his minister. The imperial library of Paris contains five volumes of the sacred writings, the Vatican contains one, the imperial library at Vienna one, the library of the Leyden university two, and the Bodleian library at Oxford four. There are also several less important MSS. in the hands of private individuals; some are owned by the American missionaries in Syria. The first three volumes in the Paris library were brought from Syria in 1700 by the physician Nasr-Allah, and presented to Louis XIV. The fourth volume was procured from the private library of M. Piques, who died in Paris in 1699. These volumes contain the exposition of the doctrines of the sect by Hamza and Boha ed-Din; they were translated into French by Petis de la Croix in 1701. The Vienna, Vatican, and Leyden MSS., with two of the Bodleian, are

duplicates of parts of the Paris MSS. Two of the Bodleian MSS. are supplementary, and contain matter not found in the writings of Hamza. From a careful study of these sources, Sylvestre de Sacy (*Exposé de la religion des Druses*, 2 vols., Paris, 1838) systematized the Druse theology. It is principally drawn from the Batenian and Ismaelite heresies, which arose within the Shiite division of Islam, in the 3d century of the Hegira, and were brought to Egypt by the invasion of the Fatimite caliphs. Traces of Gnosticism and of the Magian system of Persia are also found in the Druse writings. The characteristic dogma of the sect is the unity of God. His attributes are created and subordinate beings. He is incomprehensible, supreme, invisible, pure, the essence of true life. He can be known to his accepted children only through human manifestations. The ten Druse forms under which God has appeared are Ali, in India; Albar, in Persia; Alya, in Yemen; Moil and Kaim, in eastern Africa; Moes and Hadi, in Asia; Albu Zachariah, Mansour, and finally Hakem, in Egypt. The names are sometimes varied, but all the authorities hold that Hakem was the tenth and last earthly manifestation of God, and that no other is to be expected. He left the care of the faithful to five principal ministers, who are to direct them till the return of their divine lord. The chief of these is Hamza. His spiritual title is the "Universal Intelligence." This Intelligence, the first born of Deity, was incarnated in the person of Hamza, at the same time that Deity himself was incarnated in the person of Hakem. To him was committed the task of creation. From him comes all wisdom, all truth. He is the medium by which the Lord communicates with the lower ministers, and through them with the human family. He dispenses power, and adjusts duties in the world; and he in the last day shall be the judge and the avenger. Boha ed-Din calls him Messiah. Next to Hamza is Ismail, the "Universal Soul." His origin was the rebellion of the "Rival," which made it necessary that the Intelligence should have a supporter in the world. His office is to inspire and sanctify souls. Next to Ismail is Mohammed, the "Word," born of the union of Intelligence with Soul. He has charge of Unitarian missions, and is the spiritual cad, the chief bishop of the sect. The functions of the fourth minister, Selama, the "Preceding," seem to have been much the same with those of the fifth minister, Moktana Boha ed-Din, the "Following;" for Selama is called the "right wing," Boha ed-Din the "left wing." Both these ministers were called three years after Hakem's disappearance. They were probably intrusted with the charge of all knowledge and teaching except that of the Unitarian religion, which must come from the higher ministers. Boha ed-Din had the special duty of organizing the Unitarian sect; he knew the retreat of Hamza, consulted with him, and

from time to time produced his commands and directions. Below these five superior ministers are three styled the "Application," the "Opening," and the "Phantom;" these ministers have each his earthly figure; they are the three feet of the candlestick which holds the candle of five elements. Beneath these are three still lower classes, called Dars, Madhums, and Mokassers, who hold their dignity only by virtue of their character and abilities; they have commission to destroy false doctrine and to communicate the truth. —The Druses hold that the most precious of substances were used for the composition of man's body, and that the world at the beginning had its perfect form. Men were made male and female, young and old, in a fixed number, and no more souls have since been created. The minister of sin, the Rival, stands between the Intelligence and the Soul, and his work of temptation is hindered by the counter work of both these celestial powers. The Druse reproduction of the story of paradise makes Enoch and Seth to be the rebellious pair whose sin entailed woe upon the race. Sin broke the unity of mankind, which the Druse religion aims to restore. The mediator is Hamza. The change which he works is not in the mind of God, but in the condition and spirit of men. He baffles Satan and remits sin, but does not strictly make an atonement. Transmigration of souls is maintained, but not through the bodies of the lower animals, as in the Indian and Pythagorean systems. In passing from body to body, good men become continually better, bad men continually worse, though it is possible for them to change and become better. Ismail Temeami, the Soul, was formerly John the Baptist, and still earlier Elijah, while the soul of Hamza was once in the body of Jesus. The souls of men until the resurrection keep the embodied form, except a few whose superior excellence permits them to exist as pure spirit. At the resurrection the bodies of the faithful will be absorbed into God's own being, and transformed into spirit; all else will be destroyed. Moral teaching is summed up in seven commandments: 1, "truth in words," meaning in practice only truth to the religion and to the initiated; it is lawful to act and to speak falsehood to men of another creed, and in defence of the Unitarian faith; 2, mutual help, watchfulness, and protection; 3, to renounce all other religions; 4, to be separate from infidels of every kind, not externally, but only in heart; 5, 6, and 7, the believer must "recognize God's eternal unity," be "satisfied with God's acts," and "be resigned to God's will." Under these seven commandments numerous minor moral precepts are given, and special crimes are prohibited. Chastity, honesty, meekness, and mercy are Druse virtues; murder, theft, covetousness, cruelty, are sins. It is the opinion of intelligent writers, who have lived with them, that the average morality of the Druses is as high

as that of any other eastern religious sect.—Of the character of the Druse worship there is but little precise information in their writings. That they have no prayer or preaching to which unbelievers can listen has given rise to the report that they are without a religion. They are divided into two classes, the *ukkal* and *juhah*, the initiated and uninitiated. The former constitute the clergy, doctors, and elders, and their chief is required to observe celibacy. They superintend the ordinances of worship and instruct the children in the elements of religion. At their meetings in the *hulwehs* (meeting houses), generally on an elevation and at a distance from the villages, they invariably place a sentry to warn them of the approach of strangers. If Moslems be present, they will produce the Koran; if Christians, the Bible; and their own religious books after the infidels are gone. Women are admitted



Druse Man and Woman.

into the order if they possess the requisite intelligence. The *ukkals* are extremely simple in their dress, wearing no silk or gold. They will not touch any money or food in any other Druse's house, from fear of its having come into his possession by unfair means. They are not salaried, but subsist by their own labor. The revenue of the estates belonging to the *hulwehs* is devoted to charity. The *ukkals* are bound to peace, although some of them will fight in war. They are generally the arbitrators in disputes, and after death the saints of their people. Their proportion to the Druse population is about one to five. The *juhahs* constitute the mass of the Druses, and are instructed only in the elements of the faith. The form of government among the Druses is half feudal, half patriarchal. They are divided into three classes or ranks, the *emirs* (princes), the *sheiks* (chiefs), and the

*zlaam* (people). The emir appoints the *cadis* (judges), and has exclusive power over life and death; he collects the tribute, of which he pays a stated sum to the Porte, and keeps the surplus as his own. The emir's family never intermarry with the people. The sheiks direct almost despotically the government of the tribes within their jurisdiction. Some of them live in comparative state, but often their fare and habits are those of the common people, and they labor with the rest. They are often at strife with each other, but in foreign wars all the tribes unite under the leadership of the emir. It is a league of mountain barons, supporting a king elected without suffrage and governing without statute. The villages are usually placed near the entrance of passes, where they can be defended easily. The houses rise in terraces, till in some instances they reach the top of the mountain. The habits of the people are simple and primitive. Most of them till the soil; a few are artisans; the spinning and weaving are done by women in their houses, and the children of both sexes are kept at school. The method of fighting is not in masses so much as by ambush and in small bands. The Druses, if not the most numerous, are acknowledged to be the most warlike and courageous people inhabiting the Lebanon. Their code of martial honor is very precise; deceit between comrades is lasting shame, and cowardice is never forgotten. The relation of the sexes is far more honorable than among the Turks or Arabs. There is but one wife in the house, and her rights are admitted and protected; she can own personal property, retain the half of her dowry money after divorce, and is not compelled to marry against her inclinations.—The number of Druses in the whole of Syria, from the plain east of Damascus to the western coast, is reckoned to be about 70,000. Some of these dwell in scattered families in the larger towns, and in the villages of the Maronites. In the towns at the foot of Mount Hermon they make a considerable part of the population and have great influence. The Druses of the Anti-Libanus are more warlike and restless than their brethren beyond the Litany (Leontes). But the proper home of the Druse people is in the Lebanon mountains, from the latitude of Beyrout to that of Tyre. The principal towns are Deir el-Kamr, once the capital; Shweifat, near Beyrout; Heittat and Allaye; Abeigh, where the American Protestants have a mission; Baklin, Mukhtara, Baruk, and Ainshalti, where also there is a missionary station.—The Druses first appear in history under their founder, Hakem (996–1021). They lived under the government of sheiks who acknowledged no superior, and made frequent raids into the neighboring countries. They were engaged in almost perpetual conflict, now with the Franks as allies of the Damascus sultan, now with the sultan himself for their own independence. In 1588 Amurath III. sent an expedition against them, under



Ibrahim Pasha, who subdued them, and one of them was appointed emir, with viceregal powers, and tributary to the sultan. These emirs gradually became more formidable, till in the beginning of the 17th century the power and ambitious policy of the emir Fakhr

policy was influenced by their dictation. Their most powerful sheik, Beshir Jumblat, was his ally, adviser, and almost his rival. The alliance between these two powerful chiefs was broken about the close of 1824, when the extortions of the emir drove the Druses into revolt, and

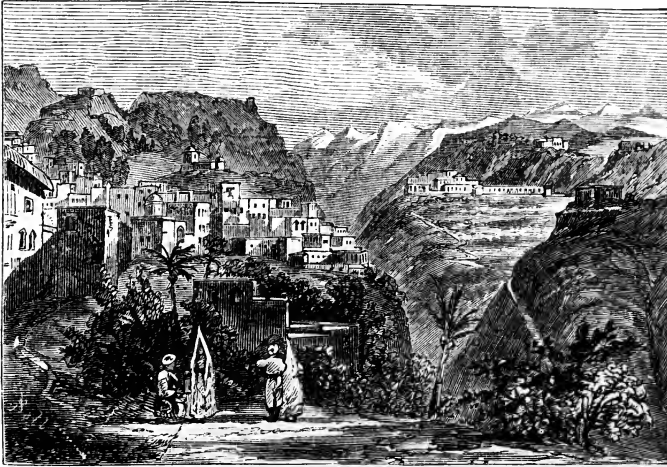

Deir el-Kamr.

ed-Din roused the Porte to action. Fakhr ed-Din fled to Italy with a large retinue, and resigned the authority to his son Ali. A palace at Pisa was appropriated to his use, and he resided there five years, at the expiration of which he was reinstated in authority over his tribe. He extended his jurisdiction until he became the virtual ruler of nearly the whole of Syria, but was finally subdued by the armies of the sultan, made prisoner and sent to Constantinople, where he was put to death, April 13, 1635. The districts of the mountain were finally parcelled to the various sheiks, as tributaries of the pasha. About 1771 these tribes made common cause against the Arab Metualis, whose rebellion against the Turks threatened to dislodge all the tributaries of the Ottoman power. In 1811 Topal Ali, then governor of a district on the banks of the Orontes, between Latakieh and Aleppo, penetrated the mountain recesses and expelled all the Druses dwelling there; 1,500 families, the survivors, fled to the Lebanon, where they were warmly received, especially as 600 families of the latter had just emigrated into the Hanran, bordering on the Syrian desert. Invaded by the Russians, the Egyptians, and by the formidable Daher, pasha of Acre, they were driven from their homes, plundered, and dispersed. Under the bloody pasha Jezzar, though the Druses suffered, yet on the whole their relative power was increased. The emir Beshir Shehaab, though a Christian by profession, belongs to the history of the Druses more than to that of the Christians in the Lebanon. His capital was in the heart of their mountains, and his

policy was influenced by their dictation. Their most powerful sheik, Beshir Jumblat, was his ally, adviser, and almost his rival. The alliance between these two powerful chiefs was broken about the close of 1824, when the extortions of the emir drove the Druses into revolt, and sent Jumblat into voluntary exile. The sheiks of the various tribes rallied to avenge his cause, but were defeated. Ibrahim Pasha, son of Mehemet Ali of Egypt, attempted to invade them in their fastnesses, without success; hundreds of his soldiers fell in trying to force one of the passes. The Druses bore a part in the strife which resulted in the restoration of Syria to the Turkish sultan. In 1842 they were again in insurrection against the Turks; and more recently they have waged a harassing warfare against their rivals the Maronites. In 1860

(May-July) a great massacre of the Christians by the Druses, seconded by the Turks, took place. Zahleh, the stronghold of the Christians, was taken by stratagem, and the inhabitants were slaughtered; 8,000 men are said to have fallen. At Deir el-Kamr the Turkish governor, who had promised to defend the Christians on condition of their surrendering, betrayed them to the Druses, who slew them to a man. Then followed the massacre of Christians by the Moslems at Damasus, Sidon, &c. Here the European powers interfered. A French army landed at Beyrout, an English fleet followed, and commissioners were sent to investigate these affairs. The ringleaders were executed, and a Christian governor was appointed in the Lebanon.—The fullest account of the Druses in English is contained in Col. Churchill's "Mount Lebanon" (4 vols. 8vo, London, 1855-'62). See also "Druses of the Lebanon," by the earl of Caernarvon (London, 1860), and *Théogonie des Druses*, translated from the Arabic by H. Guys (Paris, 1863).

**DRUSUS. I. Claudius Nero**, commonly called Drusus Senior to distinguish him from his nephew, the son of Tiberius, born in 38, died in 9 B. C. His mother, Livia Drusilla, was divorced from Claudius Tiberius Nero and married to the emperor Augustus three months before the birth of Drusus; and the latter, on the death of his father, was committed to the guardianship of his stepfather. His noble bearing and the liberality of his political sentiments won him early popularity, which was increased by the exploits of his maturer years. After obtaining permission of the senate to

fill all offices five years before the legal age, he acted as prætor in place of his brother Tiberius during the latter's absence in Gaul. In 15 he was made quæstor, and in this capacity he was sent against the Rætians, who were accused of having plundered subjects and allies of Rome, and whom he defeated as they were about to make a descent upon the plains of Italy. He afterward joined his brother Tiberius, and in conjunction with him thoroughly subdued this formidable tribe. In 13 he was appointed governor of Gaul, and in the following year defeated the Sicambrians, and afterward the Frisians, penetrating during this expedition as far as the German ocean, which he was the first Roman to reach. He is supposed to have dug a canal from the Rhine to the Yssel, and thus to have opened a way by the Zuyder Zee to the sea. Returning to Rome in 11, he was made prætor urbanus; but in the spring he renewed his campaigns in Gaul, subdued the Usipetes and several other tribes, and again returning, was allowed a triumph by the senate. In 10 he won new victories over the German tribes, and in 9 he was elected consul. But even this office could not keep him at Rome. He returned to Gaul, defeated the Catti, Suevi, and Cherusci, and penetrated to the Elbe. Here he determined, ostensibly on account of certain portents and omens, to retreat. He set out, but between the Elbe and the Sala (probably the Thuringian Saale) he was killed by the falling of his horse. **H. Drusus Cæsar**, commonly called Drusus Junior, son of the emperor Tiberius by his first wife Vipsania, died A. D. 23. During the life of Germanicus the court was divided between the parties of Germanicus and Drusus, and Tiberius took care not to declare which should succeed him. Drusus had not the dissimulation of his father, but he equalled him in impurity and in cruelty. He was quæstor in A. D. 10, and on his return from Pannonia in 15, whither he had been sent to quell a mutiny of the legions, he was made consul. He degraded the dignity of his office by his excesses, and Tiberius sent him with the army to Illyricum to teach him the art of war and remove him from the dissipations of the city. He successfully interfered in affairs of neighboring Germanic tribes, and an ovation was decreed him by the senate. In 22 he was promoted to the *tribunicia potestas*, which indicated him as the successor to the empire. Regarding Sejanus as his rival, Drusus one day struck him in the face, and the former persuaded Livia, the wife of Drusus, whose affections he had seduced, to become his murderer. A poison was administered to him which terminated his life after a lingering illness, supposed at the time to be a result of his intemperate habits; but the crime was confessed eight years afterward by the wife of Sejanus, who was privy to it.

**DRUZES.** See DRUSES.

**DRYADS** (Gr. *δρυΐς*, an oak,) wood nymphs in the Greek and Roman mythology. They are

generally considered the same as the hamadryads, and, being attached to particular trees, their life was limited by that of the tree in which they lived. Another account is that the dryads were the patrons of forests and trees in general, and were thus distinguished from the hamadryads, who inhabited each a particular tree.

**DRYANDER, Jonas**, a Swedish naturalist, born in 1748, died in London, Oct. 19, 1810. He was educated at the university of Gothenburg, and took his degree of doctor in philosophy at Lund in 1776, on which occasion he published a dissertation in opposition to the theory that fungi might be the production of animals. He became the friend and pupil of Linnæus; and visiting England as a private tutor, he resided with Sir Joseph Banks after 1782 as his librarian. He was also librarian of the royal and Linnæan societies, of the latter of which he was one of the founders. He wrote several papers on botanical subjects, and superintended the publication of the *Hortus Kewensis* and Roxburgh's "Plants of the Coast of Coromandel." He was an accomplished bibliographer, and his *Catalogus Bibliothecæ Historico-Naturalis Josephi Banks, Baroneti* (5 vols., London, 1796-1800), is a model of arrangement.

**DRYDEN, John**, an English poet, born in the parish of Aldwinckle All Saints, Northamptonshire, Aug. 9, 1631, died May 1, 1700. He belonged to a respectable Puritan family, and his father was a magistrate under Cromwell. He was the eldest of 14 children, and received a good education at Tichmarsh and at Westminster school. At the latter he showed his poetical gifts in a translation of the third satire of Persius and an elegy on the accomplished young Lord Hastings. He graduated at Trinity college, Cambridge, in 1654, and remained there till 1657. He then went to London, where his relative, Sir Gilbert Pickering, a member of Cromwell's council, gave him a petty clerkship. He celebrated the death of the protector in his "Heroic Stanzas;" but his connection with the Puritan party was the result of circumstances rather than sympathy. The restoration called forth his *Astræa Redux* in 1660, and the coronation of Charles II. another panegyric poem. At this period he eked out the pittance from his paternal estate by writing prefaces and other occasional pieces for the booksellers. The patronage of Sir Robert Howard improved his fortunes, and he soon became known as a ready versifier and a staunch royalist. His first play, "The Wild Gallant," produced in 1662, was not successful. It was followed by "The Rival Ladies" and "The Indian Emperor;" but the plague and the great fire of London put a stop to all theatrical representations, and drove him to a less profitable employment. He busied himself in composing his "Essay of Dramatic Poesy," in which he defends the use of rhyme in tragedy. In 1663 he

married Elizabeth, daughter of the earl of Berkshire, and sister of Sir Robert Howard, a lady who added a little to his fortune and less to his happiness. His *Annus Mirabilis*, "The Year of Wonders" (1667), celebrates the great fire of 1666, the duke of York's victory over the Dutch, and other prominent events. His devotion to the court no less than the merit of his verse obtained for him the appointment of poet laureate, made vacant by the death of Davenant in 1668, with that of historiographer royal, the united salaries of which amounted to £200. On the revival of the drama he became a writer for the stage, and was soon engaged to furnish for the king's theatre three plays a year, for which he received a share of the profits of the company. Though he produced only 18 plays in 16 years, the actors seem to have valued his services too highly not to take them on his own terms. But his exaggerated style did not escape the wits of the court. George Villiers, duke of Buckingham, brought out in 1671 a comedy called "The Rehearsal," in which the poet laureate was satirized under the name of Bayes. Its brilliant wit won it an enthusiastic reception. An "Essay on Satire," written by Lord Mulgrave, and attributed to Dryden, who seems indeed to have revised it, gained him the enmity of the earl of Rochester; and on Dec. 17, 1679, he was set upon at night and cudgelled by three hired ruffians. In 1681 appeared his "Absalom and Achitophel," a satire on the plot for securing the succession of Charles's natural son the duke of Monmouth, in which, under the names of David, Absalom, and Achitophel, he represented the king, Monmouth, and Shaftesbury; while in Zimri, who

— in the course of one revolving moon  
Was chemist, fiddler, statesman, and buffoon,

he drew his old enemy, the author of "The Rehearsal," and fully repaid the smart he had felt under his satire. A medal struck by the friends of Shaftesbury to commemorate the refusal of the grand jury to indict him for high treason, furnished the theme of a fresh political satire, "The Medal," which was answered by a score of rhymesters, one of whom, Elkanah Settle, by his "Medal Reversed," is said to have fairly divided with Dryden the praises of the town. "MacFlecknoe," published about 1682, was a biting satire on the poet Shadwell, and fell below Dryden's political writings in interest only because the subject was inferior. In 1682 were produced also the *Religio Laici*, a defence of the church of England, and the second part of "Absalom and Achitophel." Of this, however, the greater portion was written by Nahum Tate; Dryden contributed only 200 lines, but in these his rivals Shadwell and Settle were handed down to the ridicule of posterity under the names of Og and Doeg. A few classical translations, some miscellaneous poems, and two pieces for the stage were his

only compositions during the next three years, until he was called upon as poet laureate to mourn the death of Charles II. and celebrate the accession of James. Under the new monarch he made profession of the Roman Catholic creed. His sincerity, as the change suited so well his worldly prospects, is a moot point. He was sharply attacked by his contemporaries, and among the earliest of his pieces in defence of his faith appeared in 1687 "The Hind and the Panther," an allegory wherein the points of difference between the two religions are discussed. The revolution of 1688 deprived him of his place, and reduced him once more to the necessity of writing for bread. From 1690 to 1694 he composed four plays, and made several translations from French and Latin. During the next three years he was busy with his translation of Virgil, for which he is said to have received £1,300. In 1698 he began his adaptations of Chaucer, contracting with a bookseller to furnish 10,000 lines for £300. This bargain produced his "Fables," consisting of many of the choice stories of Homer, Ovid, Boccaccio, and Chaucer, translated or modernized in flowing verse. The noble ode for St. Cecilia's day, often called "Alexander's Feast," formed part of this collection. It was the last of Dryden's great works. He died of mortification of the leg, and was buried next to Chaucer in Westminster abbey, where John Sheffield, duke of Buckingham, erected a monument over his remains in 1720. His wife and three sons survived him.—Dryden was reserved in his habits, but kind and benevolent. At Will's coffee house he was the oracle by common consent. He was domestic in his tastes, an affectionate father, and, notwithstanding the bitter temper of his wife, a faithful husband. The licentious spirit of the time, which his dramas did everything to encourage, found no reflex in his private conduct. His rhyming tragedies have little to recommend them; his comedies, with the exception of "The Spanish Friar," are beneath his fame; and though he wrote 27 plays, only one or two are now spoken of. Many of his dedications are disfigured by abject flattery, and his early poems are marked by the false taste, Gallicisms, and unnatural conceits which characterized the period of the restoration. It was only with the production of his first political satire that he developed his full powers and marked out a new path in which he had no rival. His bold sketches of character, wanting often in polish, but alive with individuality, have never been surpassed. From the death of Milton to his own death he was confessedly the first of the English poets; but the harmony of his verse, the happiness of his illustrations, and the brilliancy of his wit, were often defiled by the coarseness of party rancor and the taint of a corrupt fancy. Dryden produced the first good English version of the *Æneid*. In prose he has left many specimens of strong, genuine English, mostly in the form of prefaces and dedications. Among the

principal editions of his works are his dramas (6 vols. 12mo, London, 1718); miscellaneous works (4 vols., 1760); prose works, edited by Malone (4 vols. 8vo, 1800); and a complete edition of all his writings, with notes and a memoir by Sir Walter Scott (18 vols. 8vo, Edinburgh, 1808). The "Fables," ornamented with engravings after the designs of Lady Diana Beauclerc, were published in folio (London, 1797). The life of Dryden has been written by Dr. Johnson, and forms the most eloquent and discriminating of all his "Lives of the Poets."

**DRYING OILS.** A number of vegetable oils, as linseed, nut, poppy seed, and some others, exhibit a strong tendency to absorb oxygen from the air, and, when exposed in thin layers, to dry into a resinous kind of varnish. The addition of a small quantity of oxide of lead greatly accelerates the process. These oils are consequently well suited for mixing with coloring matters to form paint for wood work. They impart no color of their own, and serve to bind and secure the color to the wood, which they also aid to protect by their resinous coat. The so-called greasy oils have no such tendency to dry by exposure, but become rancid.

**DRY ROT,** an affection of timber which is often very rapidly destructive to ships, and to damp, ill ventilated houses. A general characteristic is the development of fungi, especially the *polyporus hybridus*, *thelepora puteana*, and *merulius lachrymans*, and also of lower forms. These growths are at the same time accompanied, although not necessarily in a corresponding degree, by a slow decay, akin to eremacausis. The only practical means of arresting dry rot is to expose the fibres of the timber to the action of certain metallic salts, or other substances which have the power of depriving the fungi of life and of so fixing the organic constituents of the wood as to prevent their oxidation. An ordinary process, long practised, is that of kyanizing (so called from being extensively employed by Mr. Kyan, at the suggestion of Sir Humphry Davy), which consists in steeping the wood in a solution of corrosive sublimate. The success of this process has been questioned, and the use of other salts has been introduced. Sir William Burnet has proposed chloride of zinc for preserving not only wood, but also canvas and cordage. Carbolic acid has been successfully employed, as also creosote, gas tar, and other coal products. Sulphate of iron and calcium chloride, in Payne's process, are much used in Great Britain. This process is as follows: Into a large cylinder several pieces of timber are introduced; steam is forced in, by which most of the air is driven out; then a cold solution of sulphate of iron is let in, which, condensing the steam, produces a partial vacuum, which is completed by the air pump. The liquid flows into the pores, and is further forced into them by pressure. The iron solution is then allowed to flow off, when steam is again introduced and applied until all or nearly all moisture in

the timber is vaporized. A cold solution of calcium chloride is then allowed to flow in; a vacuum is again produced, and the calcium salt enters the pores, and forms, by double decomposition with the iron salt, ferric chloride and sulphate of lime, or gypsum. A variation of the process has been used to stain and prepare common woods in imitation of rarer and more durable kinds.

**DRY TORTUGAS,** a group of ten islets or keys forming part of Monroe co., Florida, at the extremity of the Florida Keys, 120 m. W. S. W. of Cape Sable, the S. point of the state; pop. in 1870, 237. They lie just within the gulf of Mexico, in about lat. 24° 37' N., lon. 83° W. The islets, which are of coral formation, are low and barren except where partly covered with mangrove bushes. On Bush or Garden Key is Fort Jefferson, which in 1870 was garrisoned by 98 men. A lighthouse has been erected on the same islet. During the civil war the fort was used as a penal station for confederate prisoners, and in 1865 O'Laughlin, Spangler, Arnold, and Mudd, found guilty by a military commission of participation in the assassination of President Lincoln, were sent thither to serve out their terms of imprisonment, but were pardoned by President Johnson, except O'Laughlin, who died there. Prisoners under sentence of court martial are occasionally confined at Fort Jefferson.

**DUALLINE.** See EXPLOSIVES.

**DUANE, William,** an American politician and journalist, born near Lake Champlain, N. Y., in 1760, died in Philadelphia, Nov. 24, 1835. At the age of 11 he was taken by his mother to her native country, Ireland, and liberally educated; but having forfeited her protection by marrying against her will at the age of 19, he learned the art of printing, and in 1784 went to India. There he amassed property rapidly, and became editor of an Indian journal entitled "The World." Having taken sides against the local government in a dispute with some of its troops, he was seized and sent to England, and his large fortune was confiscated. After in vain petitioning parliament and the East India company for redress, he became editor of the "General Advertiser," siding in politics with the party of Horne Tooke and others. In 1795 he returned to America, and became editor of the "Aurora," published at Philadelphia, making it the most influential organ of the democratic party. The change of the seat of government to Washington caused the "Aurora" to decline in political importance. Duane retired from its editorship in 1822, and travelled through the republics of South America. On his return he published an account of these travels, and was appointed prothonotary of the supreme court of Pennsylvania for the eastern district, an office which he retained until his death. He served in the war of 1812, and published a "Military Dictionary" (Philadelphia, 1810), and a "Handbook for Rifle-men" (1813).

**DUBAN, Jacques Félix**, a French architect, born in Paris, Oct. 14, 1797, died at Blois in September, 1870. He studied in the school of fine arts, which in 1823 awarded a prize to his design of a custom house. After spending about five years in Italy, he completed in Paris the palace of the fine arts, which had been begun by Debret. He restored the palaces of Blois and Dampierre, and executed many works for the embellishment of the Louvre, of which he was the architect from 1848 to 1854, when he became inspector general of public buildings, and member of the institute.

**DU BARRY.** See BARRY.

**DUBLIN. I.** An E. county of Ireland, in the province of Leinster, bordering on the Irish sea and the counties Meath, Kildare, and Wicklow; area, exclusive of Dublin city, 348 sq. m., of which 306 are arable; pop. in 1871, including the city, 405,625. It has a coast line, inclu-

ding windings, of 70 m., comprising the natural harbors of Dublin bay, Killiney, Malahide, Rogerstown, and Lough Shinney, with harbors constructed by art at Kingstown, Howth, and Balbriggan. The only river of importance is the Liffey. The county is generally level, but on the southern boundary rises a range of hills, culminating in the peak of Kippure at a height of 2,473 ft. Near these extend the Dublin mountains, the central group of which is 1,000 to 1,200 ft. high; toward the north are picturesque valleys and cultivated heights, and on the coast are many bold promontories. The geological formation is mostly mountain limestone, bounded S. by a ridge of granite. The soil is shallow, and in general not well adapted to agriculture, but careful drainage and manuring have rendered much of it productive. The principal crops are wheat, oats, barley, rye, potatoes, and turnips. Grazing and

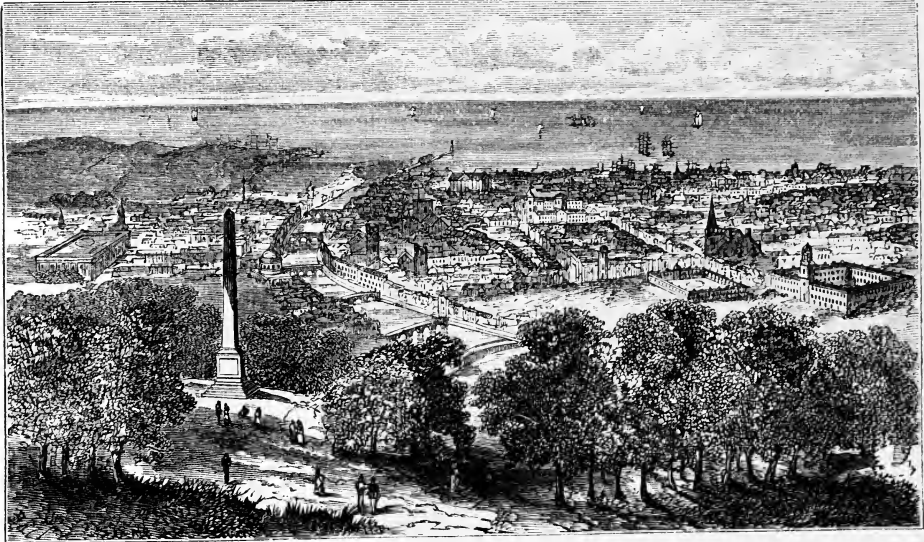

View of Dublin from Phoenix Park.

the fisheries form important branches of industry. Lead and copper are mined to a small extent at Ballycorus. The manufactures are limited to stockings, cotton, and a few other fabrics. The principal towns, besides the city of Dublin, are Kingstown and Rathmines. **II.** The capital of the county and of Ireland, a municipal and parliamentary borough and seaport, situated at the head of Dublin bay, on both sides of the Liffey, in lat.  $53^{\circ} 23' N.$ , lon.  $6^{\circ} 20' W.$ , 292 m. W. N. W. of London and 63 m. W. of Holyhead; pop. in 1871, with the suburbs, 295,841; without the suburbs, 245,722. The Liffey is navigable to the centre of the city, which is divided into two nearly equal portions. Its entrance is obstructed by a sand bar, on which at low ebbs there is not more than 9 ft. of water, although in spring tides it has 24 ft. At the mouth of this river in Dub-

lin bay lies the harbor, formed by two breakwaters, one projecting E. into the bay S. of the river, the other running out from the shore beyond Clontarf, N. E. of the city, and nearly meeting the former at an angle of  $40^{\circ}$ . The area thus enclosed at high water spring tides is 3,030 acres, and by systematic dredging the channel has been so deepened as to admit vessels of 1,400 tons. The wharves and docks connected with the custom house are extensive. There is a lighthouse at the end of the S. breakwater, and in other parts of the bay are two other lights. A harbor of refuge has been constructed at Kingstown. The entrances at the port in 1871 were 7,286 vessels, tonnage 1,299,644; clearances, 3,745 vessels, tonnage 992,126. The trade of Dublin is chiefly with the midland districts, which it supplies with tea, coffee, sugar, tobacco, tim-

ber, deals, wines, and other foreign products, and with the English markets, to which it exports cattle and agricultural produce. With the United States its commerce is small, and confined mostly to timber. It has but few manufactures, and those of trifling value. Iron casting, cabinet making, and manufactures of the minor articles of jewelry and apparel are thriving, but afford employment to a very small part of the population. The manufacture of silk poplins was introduced by Huguenot refugees, and still flourishes to some extent. The well known Dublin porter is an important item in the trade of the city. The number of hogsheads exported in 1855 was 87,905; in 1862, 156,077; in 1871, 281,301. The quantity of distilled liquors exported in 1869 was 2,196 butts and puncheons, 4,520 hogsheads, 1,193 casks, and 3,268 quarter casks:—The modern part of Dublin is regularly built, without much architectural display, but with an appearance of substantiality and comfort. The lower part is occupied by filthy streets of wretched tenements, inhabited by people as poor as their dwellings. In hardly any other city are wealth and poverty in such close and marked contrast. But the general aspect to strangers who follow the main thoroughfares is very favorable. The S. W. quarter is occupied by the poor, the N. W. by the middle classes, the S. E. and N. E. being the residence of the wealthy. The thickly populated part of the city has an extent of about  $1\frac{3}{4}$  m. in each

direction, but with the remainder it covers a space of  $2\frac{1}{2}$  by 2 m. It is paved, lighted with gas, and supplied with water by works completed in 1868. Nine bridges, of which two are of iron, span the river, and an avenue called the Circular road, 9 m. long, encompasses the city. The public buildings are noted for their elegance. The bank of Ireland, in College green, was formerly used as the Irish parliament house. It is nearly semicircular with a fine Ionic colonnade. The chamber of lords remains as when last used. Immediately opposite the bank is Trinity college, an imposing Corinthian structure. It was founded under authority of Pope John XXII., closed in the time of Henry VIII., and reopened by Elizabeth, who incorporated it in 1592 as the college of the holy and undivided Trinity. It contains a small museum, and an extensive library, rich in ancient MSS. Trinity college has a large faculty and about 1,300 students. Roman Catholics were for the

first time admitted to scholarships in 1856. The queen's university, incorporated in 1850, with power to confer degrees on students of the queen's colleges of Belfast, Cork, and Galway, holds the meetings of its senate at Dublin castle. The Roman Catholic university in Stephen's green was founded in 1854. Among the other literary and scientific institutions are the colleges of physicians and of surgeons, apothecaries' hall, and medical societies; the royal Dublin society, having museums of natural history and of agriculture, a botanic garden, a gallery of statues, a library numbering over 30,000 volumes, a school of art, and free lectures; the royal Hibernian society of art, with an annual exhibition of paintings; the royal Irish academy of science, literature, and antiquities; the royal college of science, opened in November, 1868; the archæological society, society of engineers, mechanics' institute, statistical, geological, and zoölogical societies, nu-

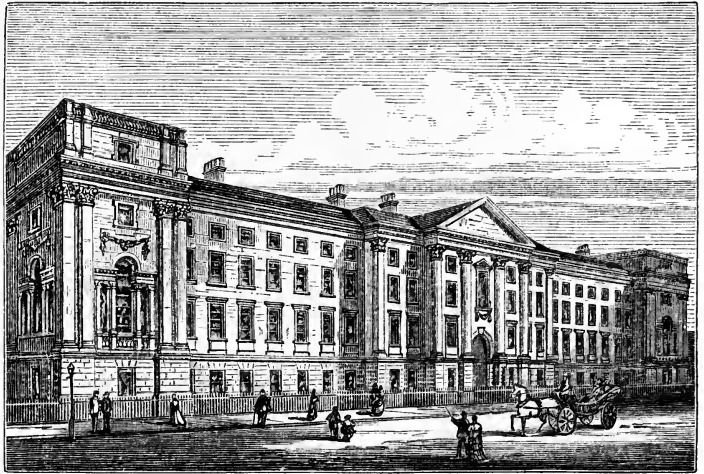

Trinity College.

merous other associations and reading societies, upward of 200 charity schools, and several libraries. An agricultural college at Leopardstown, near Dublin, has a farm of 200 acres. An act of parliament was passed, Aug. 10, 1854, to provide for the establishment of a "national gallery of paintings, sculpture, and the fine arts," for the care of a public library, and the erection of a public museum; and the building was begun in 1859, and opened in 1864. It forms a northern wing to the premises of the royal Dublin society, its gallery end facing Merrion square, and the corresponding southern wing being devoted to the new museum. Although entitled the national gallery, it is also intended as a testimonial in commemoration of Mr. William Dargan's exertions in behalf of the great Dublin industrial exhibition of 1853. The cost of construction was £26,739. Thirty newspapers and periodicals were published in Dublin in 1873,

among which were eight dailies. The castle, the residence of the viceroy, stands on an elevation, but is not an imposing edifice. The Four Courts are a pile of building of Corinthian architecture, with a frontage on the Liffey of 500 ft., and occupied by the courts of queen's bench, chancery, exchequer, and common pleas. The custom house is of the Doric order, and is surmounted by a cupola 125 ft. high. Other noticeable structures are the general post office, with an Ionic front, of considerable elegance; the city hall and exchange; the magnificent freemasons' hall, erected in 1868; commercial buildings, in which is the chamber of commerce; the queen's inns, linen hall, the weavers' hall, corn exchange, conciliation hall, the theatre, several barracks for constabulary and troops; Stephen's hospital for 300 patients; the Meath, city of Dublin, Sir Richard Dun's, and Richmond surgical hospitals, and royal hospital, designed by Sir Christopher Wren,

Wesleyan, 2; Wesleyan Methodist, 8; Friends', 2; Baptist, Moravian, Catholic Apostolic Church, Welsh Presbyterian, and Jewish, each 1. Among the chief streets and public places of Dublin are Grafton street, passing into College green, in which is an equestrian statue of William III., and connecting by Carlisle bridge with Sackville street, containing a column to the memory of Nelson; Dame street, containing many of the finest shops; St. Stephen's green, a square one mile in circumference, tastefully planted, and having a statue of George II.; College park, Fitzwilliam, Rutland, and Mountjoy squares. The celebrated Phoenix park comprises an area of 1,752 acres. A granite obelisk has been erected to Wellington on the left of the entrance. There is a statue of Thomas Moore, erected in 1857; and a colossal statue of Daniel O'Connell has been placed in the city hall. Among the public testimonials more recently erected in Dublin are: a fountain

with a bust of the eminent surgeon Sir Philip Crampton, erected in 1862, at the end of College street; a full-length statue of Oliver Goldsmith, in front of Trinity college, by Foley, in 1863; statues of the earl of Eglington, on the N. side of Stephen's green, in 1866; of Edmund Burke, by Foley, in 1868; of Smith O'Brien, by Farrell, in 1870; and of Prince Albert, by Foley, in 1872. Glasnevin is a pleasant suburb, containing the botanic garden of the royal Dublin society, and was the favorite residence of Addison, Steele, Swift, and Sheridan; and Glasnevin cemetery contains

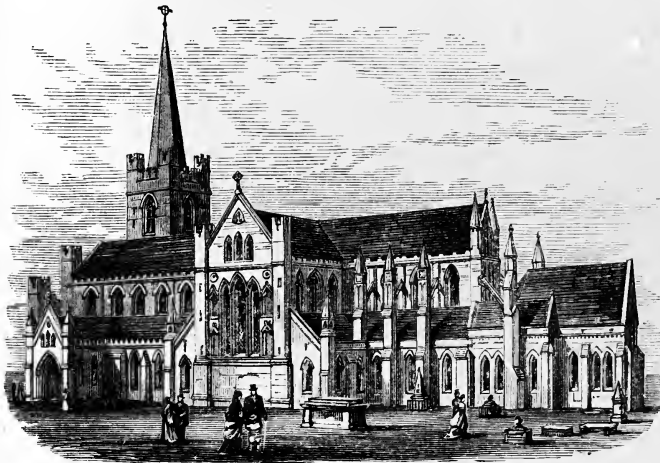

St. Patrick's Cathedral.

for disabled soldiers; and St. Patrick's hospital, erected from a legacy left by Dean Swift. The county jail stands W. of the suburbs, at Kilmainham. Within the city are the Newgate, city and four courts, and marshalsea prisons, the bridewell or house of correction, Smithfield penitentiary, penitentiary for females, and house of industry. Dublin is the seat of a Protestant and a Roman Catholic archbishop, and has two ancient cathedrals of the Anglican church, those of St. Patrick and of the Holy Trinity, and a modern Catholic cathedral. St. Patrick's cathedral was thoroughly restored in 1865, at a cost of £150,000, which was defrayed by Sir B. L. Guinness. The Anglican church has 20 parish churches and 20 non-parochial places of worship; the Roman Catholics have 9 parochial places of worship, 6 friaries, a Jesuits' church, 3 monasteries, and 8 convents; the other places of worship are: Presbyterian, 6; Unitarian, 2; Independent, 3; Primitive

the tombs of O'Connell, "Tom Steele," and Curran. The Royal and Grand canals flank the city N. and S., and four railways give communication with Galway, Cork, Belfast, &c. Steam packets ply regularly to Holyhead, Liverpool, London, Bristol, Cork, Glasgow, &c. The environs of Dublin are remarkably beautiful. The bay, one of the finest in the United Kingdom, is 7 m. wide at its entrance, between Howth head on the north and Kingstown on the south, and extends inland about the same distance, with a somewhat increased width. The civic government is by the municipal reform act vested in a corporation consisting of a lord mayor chosen annually from among the aldermen or town councillors, 15 aldermen, and 45 councillors, there being one alderman and three councillors from each of the 15 municipal wards. The corporate income amounted in 1871 to £196,175, the expenditure to £192,577, and the debt to £782,-

609. The city sends two members to parliament, and Trinity college two.—Dublin claims a high antiquity. Curious Celtic remains were found in 1856 within the town walls of ancient Dublin. It is the *Eblana* of Ptolemy; Irish *Dubh-linn* (black pool); Danish *Dyflin* and *Dyrelin*. About the middle of the 9th century it was taken by the Danes. The records of the next three centuries are little else than a succession of bloody battles. In 1170 it was taken by the English under Strongbow, who died and is buried there. In 1205 the castle was built; in 1190, 1283, 1301, and 1304, the city was burned; in 1405 the citizens made a descent on Wales for Henry IV. During the first half of the 16th century it was troubled by the Kildare family, one of whom, Lord Thomas Fitzgerald, among other exploits, murdered the archbishop. During Richard Cromwell's feeble protectorate the city was seized by the cavaliers, recovered by the parliamentarians, and again captured by the partisans of the king. In 1798 a conspiracy to seize the city and castle was frustrated by the arrest of Lord Edward Fitzgerald and others. In 1803 occurred Emmet's insurrection.

**DÜBNER, Friedrich**, a German philologist, born at Hörselegau, near Gotha, Dec. 21, 1802, died Oct. 13, 1867. In 1826 he was appointed professor in the gymnasium at Gotha, and during the five years that he held this post published philological articles in the periodicals, and especially became known by his edition of Justin. His principal studies were upon the ancient comic authors, and he resigned his professorship in order to visit Italy and collate the original manuscripts. At this time Didot invited him to Paris to assist in preparing a new edition of Stephens's *Thesaurus*, a call which the valuable manuscripts contained in the Parisian libraries induced him to accept. He was employed on the *Bibliotheca Græca* which Didot had undertaken, and contributed the critical editions of the *Moralia* of Plutarch, of Arrian, Maximus Tyrius, and Ilmerius, and the scholia to Aristophanes and Theocritus. He also took part in preparing the Parisian editions of St. Augustine and St. Chrysostom. In 1855 he published an elementary Greek grammar, and in 1860 a French-Greek lexicon, besides some works on education.

**DUBNO**, a town of European Russia, in the government of Volhynia, on the Ikva, 36 m. N. E. of Brody; pop. in 1867, 7,628. It has narrow, crooked, and unpaved streets, and belongs to the princes Lubormirski, whose residence is here. The town contains several Greek and Roman Catholic churches, a Greek abbey, and a grammar school. Its trade is chiefly in grain, flax, tobacco, cattle, and fish.

**DUBOIS**, a S. W. county of Indiana, bounded N. by the E. fork of White river, and intersected by Patoka creek; area, 420 sq. m.; pop. in 1870, 12,597. It has a slightly diversified surface, and is covered with thick forests; the soil is good, and coal is abundant. The

chief productions in 1870 were 120,636 bushels of wheat, 373,817 of Indian corn, 110,868 of oats, 24,796 of potatoes, 45,738 lbs. of butter, 34,738 of wool, and 358,948 of tobacco. There were 3,428 horses, 3,061 milch cows, 6,081 other cattle, 12,730 sheep, and 21,782 swine; 2 breweries, 2 saw mills, and 3 manufactories of carriages. Capital, Jasper.

**DUBOIS. I. Antoine**, a French surgeon, born at Gramat in 1756, died in Paris, March 30, 1837. He went to Paris at the age of 20 and attended the philosophical course at the Mazarin college, supporting himself meanwhile by giving lessons in writing and by copying for lawyers. He then studied medicine under Desault, who made him his assistant. He advanced rapidly, and in 1790 became a professor in the royal college of surgery, a position in which, although he published no works, he acquired a reputation all over Europe. Bonaparte selected him as one of the corps of savants who accompanied him to Egypt, and in 1811 intrusted him with the *accouchement* of the empress Marie Louise, a service which he performed with so much skill that both mother and child probably owed their lives to him. Under the consulate and empire he was also made surgeon-in-chief of a newly established hospital, still known as the hospital Dubois, and professor of obstetrics in the maternity hospital, besides receiving the title of baron. He devised new processes in many operations, and invented and perfected a great number of instruments, among others the forceps which bears his name. His publications were confined to articles contributed to periodicals, mostly to the *Dictionnaire des sciences médicales*. **II. Paul Antoine**, a French obstetrician, son of the preceding, born in Paris, Dec. 7, 1795, died there in December, 1871. In 1823 he succeeded his father at the maternity hospital, and in 1830 was appointed professor of obstetrics in the faculty of medicine, and soon became distinguished for his skill in diagnosis, his clear and eloquent manner of lecturing, and a peculiar facility for imparting knowledge. His lectures and clinics were widely known and very fully attended. He became dean of the faculty in 1852, and in 1863 he was compelled to retire from active occupation, owing to a failure of memory, the first symptom of a mental disorder which became confirmed, and continued during the remainder of his life. His writings consisted entirely of contributions to medical journals.

**DUBOIS, Guillaume**, a French cardinal and statesman, born in Brive-la-Gaillarde, Limousin, Sept. 6, 1656, died in Versailles, Aug. 10, 1723. He was the son of an apothecary, went at an early age to Paris, studied in one of the colleges, and became a private teacher, and eventually tutor to the duke de Chartres, afterward duke of Orleans. He flattered his young pupil, persuaded him to marry Mlle. de Blois, a natural but legitimized daughter of Louis XIV., and was rewarded with a rich abbey in



Picardy, and sent on a mission to England. On his return to Paris he acted as private secretary to the duke; and when on the death of Louis XIV. in 1715 the latter was invested with the regency, Dubois became a member of the council, and exerted a prominent influence on foreign affairs. He concluded in 1717, in concert with Lord Stanhope, the famous triple alliance of France, England, and Holland against Spain, subsequently made a quadruple alliance by the adhesion of Austria. After becoming minister of foreign affairs, he baffled the conspiracy of the Spanish ambassador Cella mare, instigated by the Spanish prime minister Alberoni, to make Philip V. of Spain regent of France in place of the duke of Orleans. A war with Spain ensued, which resulted in the fall of Alberoni and the submission of Philip to the stipulations of the quadruple alliance. Dubois was appointed archbishop of Cambrai, and eventually cardinal, prime minister, and member of the French academy. His administration was marked by a certain degree of vigor, and he unquestionably had great ability; but his life on the whole presents a hideous array of selfishness and shameless vices. When the operations of the Scotch financier Law brought the country to the verge of bankruptcy, and while the regent was spending his time in debauchery, Dubois availed himself of the opportunity to amass an immense private fortune, derived from regular revenues, an English pension, and the benefits accruing from the six abbeys of which he was the incumbent, independent of the see of Cambrai. A record of his private life appeared in 1789, and his memoirs in 1817. Those published in 1829 are not authentic.

**DUBOIS, Jean Antoine**, a French missionary, born at St. Remèze, Languedoc, in 1765, died in Paris, Feb. 7, 1848. He spent 32 years in the East Indies, and on his return published "Letters on the State of Christianity in India" (London, 1823), which produced much controversy in England, because it expressed his disbelief in the possibility of the conversion of the Hindoos. He wrote several remarkable works relating to the religion and the traditions of India, and many contributions to the *Bulletin des sciences*, and to the journals of the Asiatic societies of London and Paris, of which he was a member. His most celebrated work, "Description of the Character, Manners, and Customs of the People of India, and of their Institutions, religious and civil," was published by the East India company in London in 1816, and an enlarged edition was published in French under the title of *Mœurs, institutions et cérémonies des peuples de l'Inde* (Paris, 1825).

**DU BOIS-REYMOND, Emil**, a German physiologist, born in Berlin, Nov. 7, 1818. He studied under Johannes Müller, succeeded him in 1858 as professor of physiology in the university of Berlin, and became in 1867 perpetual secretary of the academy. He stands at the head of the German physiologists and of the

school of positive science, and counts many distinguished savants among his followers. He is an especial authority on animal electricity. His principal work is *Untersuchungen über thierische Elektrizität* (2 vols., Berlin, 1848-'60). His *Gedächtnissrede auf Johannes Müller* (1860) contains an interesting summary of the recent progress in anatomy and physiology. Among his other works is *Voltaire in seiner Beziehung zur Naturwissenschaft* (1863).

**DUBOS, Jean Baptiste**, a French critic and historian, born in Beauvais in December, 1670, died in Paris, March 23, 1742. The best known of his numerous works is his *Histoire critique de l'établissement de la monarchie française dans les Gaules* (3 vols. 4to, Paris, 1734). The theory which he maintains in this work, that the occupation of Gaul by the Franks was a settlement and not a conquest, has been contested by Montesquieu and others. Of his *Réflexions critique sur la poésie et la peinture* (2 vols. 12mo, 1719; 6th ed., 1755), there is an English translation (London, 1748).

**DUBOSARY**, a town of southern Russia, in the government of Kherson, on the Dniester, 85 m. N. W. of Odessa; pop. in 1867, 5,547. It has two churches and a synagogue. Its trade is largely in tobacco, raised in the vicinity.

**DUBOVKA**, a town of southern Russia, in the government and 180 m. S. S. W. of the city of Saratov, on the Volga; pop. in 1867, 13,676. It carries on a brisk river trade in wood, grain, iron, oil, and some manufactures; much of the produce of northern Russia intended for the southern provinces is shipped here.

**DUBS, Jakob**, a Swiss statesman, born at Affoltern, canton of Zürich, in 1822. He studied law at the universities of Bern, Heidelberg, and Zürich, and was elected in 1847 a member of the grand council, and subsequently held various offices in his native canton. He became in 1855 a member, and in 1857 president of the federal court. He was president of the confederation in 1864, and again in 1870, having served meanwhile in the federal council. He belongs to the liberal party, and is distinguished for the reforms which he inaugurated in the administration of justice and in education. He has written *Entwurf eines Strafgesetzbuches für den Canton Zürich* (1855), *Entwurf eines Gesetzes über den Unterricht* (1857), and *Die schweizer Demokratie in ihrer Fortentwicklung* (1868).

**DUBUFE, I. Claude Marie**, a French painter, born in Paris about 1790, died there, April 21, 1864. He studied with David, and for many years attempted historical paintings on a grand scale, which met with little favor. In 1827 he exhibited two sentimental pictures entitled "Souvenirs" and "Regrets," which, in spite of much hostile criticism, became very popular through the medium of engravings. After executing several similar works, he turned his attention to portraits, by which he acquired reputation and fortune. He painted the likenesses of many distinguished persons, inclu-

ding Louis Philippe and his daughter, the queen of the Belgians. In 1850 two large pictures by Dubufe, representing the temptation and expulsion of Adam and Eve from paradise, were extensively exhibited in the United States. **II. Édouard**, son of the preceding, born in Paris about 1818. He studied under his father and Paul Delaroche, and for some years followed successfully the sentimental style of his father's "Souvenirs" and "Regrets." Afterward he painted Scriptural subjects, but later, following the example of his father, he confined himself more to portrait painting. Among his most successful works are portraits of the empress Eugénie, Rosa Bonheur, and the members of the congress of Paris. Two paintings called "The Conscript's Departure" and "The Soldier's Return," and a large painting of "The Prodigal Son," have been exhibited in the United States, and the last has been engraved.

**DUBUISSON, Paul Ulrich**, a French author, born in Laval in 1746, guillotined March 23, 1794. He went when young to Paris, and wrote for the stage with small success. He was one of the most jealous of authors, and was accustomed to fill his prefaces with abuse of the contemporary writers who surpassed him, the actors who refused to flatter him, the journalists who jested at him, and the public who neglected him. He went to America, thence to Belgium, and returned to France a few years before the outbreak of 1789. He embraced the cause of the revolution with enthusiasm, became associated with the Jacobin club, and having taken part in the schemes of Hébert, Ronsin, and Anacharsis Clootz, he shared their fate. He published tragedies and comedies, *Abrégé de la révolution des États d'Amérique* (1778), and *Lettres critiques et politiques sur les colonies et le commerce des villes maritimes de France* (Paris, 1785).

**DUBUQUE. I.** An E. county of Iowa, bordering on Illinois and Wisconsin, bounded N. E. by the Mississippi, and watered by the N. and S. forks of the Maquoketa; area, 600 sq. m.; pop. in 1870, 38,969. It is hilly and well timbered, with a fertile soil. Limestone underlies the greater part of the surface. It is very rich in lead, and about 100 mines are in operation throughout the year, while in the winter three times that number are worked. The chief productions in 1870 were 495,244 bushels of wheat, 1,311,789 of Indian corn, 834,320 of oats, 75,739 of barley, 163,881 of potatoes, 37,393 tons of hay, 437,149 lbs. of butter, and 31,384 of wool. There were 8,425 horses, 10,434 milch cows, 15,034 other cattle, 9,682 sheep, and 37,232 swine. **II.** The chief city of Iowa in population, capital of the county, situated on the right bank of the Mississippi, directly opposite the boundary of Illinois and Wisconsin, and 460 m. by river above St. Louis; pop. in 1850, 3,108; in 1860, 13,000; in 1870, 18,434, of whom 6,524 were foreigners; in 1873, 22,151. The city is built partly on a terrace

20 ft. above high-water mark, and partly on the bluffs, which rise about 200 ft. The lower or business portion is regularly laid out and compactly built, while in the upper portion the streets rise picturesquely one above another. The United States building, accommodating the custom house, post office, and federal courts and officials for the northern district of Iowa, is of marble, three stories high, and cost over \$200,000. The central market building, a three-story brick edifice, surmounted by a cupola, serves both for market purposes and city offices and council chamber; the third story consists of a single room, 45 by 145 ft., known as the city hall. Three of the ward school houses are each 52 by 80 ft., three stories high, with a basement, and wings on either side, 10 by 30 ft., and cost \$25,000 each. The fourth ward school house is 70 by 50 ft., two stories high, with a basement and a large hall, and cost \$18,000. The Methodist Episcopal, one of the Presbyterian, the Universalist, the Congregational, and St. Mary's (German Catholic) churches, and the cathedral, are imposing structures, the three last being surmounted by lofty spires. The Dubuque and Sioux City, the Dubuque Southwestern, the Chicago, Dubuque, and Minnesota, the Chicago, Clinton, and Dubuque, and the Illinois Central railroads furnish means of communication to all parts. The city was made a port of delivery in 1854. In 1872 there were 62 vessels, with an aggregate tonnage of 3,606, belonging to the port, of which 17 of 1,517 tons were steamers, and 45 of 2,089 tons canal boats. Dubuque is the commercial centre of the great lead region of Iowa, N. W. Illinois, and S. W. Wisconsin. From 10,000,000 to 20,000,000 lbs. of lead, worth from \$500,000 to \$1,000,000, are shipped annually. Some of the mines are within the city limits, and the best within a few miles of it. Extensive warehouses have been erected on the levee, and large elevators for the grain trade. There are 3 national banks, with an aggregate capital of \$500,000, and 3 savings institutions, with \$350,000 capital. In 1870 Dubuque county contained 297 manufacturing establishments, chiefly in the city, employing 1,780 hands; capital invested, \$1,636,775; annual value of products, \$3,308,399. The most important were 5 manufactories of agricultural implements, 14 of carriages and wagons, 15 of clothing, 6 of furniture, 2 of iron castings, 1 of japanned ware, 1 of bar and sheet lead, 2 of pig lead, 1 of shot, 2 of engines and boilers, 4 of sash, doors, and blinds, 3 of soap and candles, 9 of tin, copper, and sheet-iron ware, 1 of tobacco and snuff, 4 planing mills, 6 saw mills, 14 breweries, 2 distilleries, and 16 flour mills. The machine shops of the Chicago, Dubuque, and Minnesota railroad, situated here, are among the most extensive in the west.—Dubuque is divided into five wards, and is governed by a mayor and a board of two aldermen from each ward, together constituting the common council. There

are also a treasurer, auditor, assessor, recorder, city attorney, and city marshal. The streets are all macadamized, provided with gutters and sidewalks, and lighted with gas, and pure spring water is carried to every part of the city from a reservoir containing 3,000,000 gallons, through 10 m. of mains. The amount in the treasury, March 1, 1872, was \$34,252 83; receipts for the year ending March 1, 1873, \$183,724 12; total, \$217,976 95. The disbursements were \$205,782 80, including \$81,088 40 on principal of debt, \$38,685 92 for interest, \$7,032 96 for poor relief, \$7,378 08 for gas, \$27,684 42 for streets, \$5,160 84 for fire department, \$5,246 20 for water department, and \$10,049 56 for salaries. The city debt is about \$900,000; the assessed value of property about \$17,000,000; true value, \$23,000,000. The schools are under the management of a board of seven directors. There are ten school houses, including one for colored children, and a high school; number of pupils enrolled in 1873, 2,880; average attendance, 2,117; teachers, 66, of whom 7 are males. The school expenditure in 1872 was \$44,132 85, which includes \$30,317 75 for teachers' wages. The German theological seminary (Presbyterian) in 1872 had 2 professors, 17 students, an endowment of \$15,000, and a library of 600 volumes. There are three daily newspapers and five weekly (two German). There are 14 churches, viz.: Congregational, Methodist Episcopal, Universalist, Roman Catholic (3), Lutheran, Dutch Reformed, Presbyterian (2), Episcopal, Christian, Old School Methodist, and one unknown.—Dubuque is the oldest settlement in the state, and derives its name from Julien Dubuque, a French Canadian, who established himself here in 1788; its permanent settlement, however, dates only from 1833, when the Indian title to the land was extinguished. It was incorporated as a town in 1837, and in 1840 a city charter was granted.

**DUJ, Joseph Louis**, a French architect, born in Paris, Oct. 25, 1802. He entered the school of fine arts in 1821, where he took the grand prize in 1825. With Alavoine he built the column of July, and he was associated with Vaudoyer in the construction of the cathedral of Marseilles. His most noted work is the enlargement and restoration of the palace of justice in Paris, in which he was assisted by Dommev. For this he was awarded by his colleagues of the academy in 1869 the grand prize of 100,000 francs, offered by Napoleon III. in 1864 for the greatest work of painting, sculpture, or architecture which should be produced within the ensuing five years. His principal competitor for the prize was M. Lefuel, the architect of certain parts of the Louvre. Out of the 100,000 francs he paid 40,000 into the treasury of the institute of France, to found an annual prize for the encouragement of architecture.

**DU CAMP, Maxime**, a French artist and author, born in Paris, Feb. 8, 1822. On leaving college he travelled extensively in the East in

1844-'5, and again in 1849-'51. During his last journey he made a large collection of photographic negatives of scenes in Egypt, Nubia, Palestine, and Asia Minor, which he has since published in connection with descriptive texts, in several volumes. In 1851 he was one of the five founders of the *Revue de Paris*, and he contributed to it both in prose and verse until its suspension in 1858. Besides his works of travel in the East, he has published *Les chants modernes*, poems (8vo, 1855); *Mes convictions*, poems (8vo, 1858); *En Hollande, lettres à un ami* (12mo, 1859); *Erpédition des Deux-Siciles* (18mo, 1861); *Paris, ses organes, ses fonctions et sa vie* (1869). The last was contributed to the *Revue des Deux Mondes*. He has also written several romances.

**DU CANGE, Charles du Fresne**, sieur, a French historian and philologist, born in Amiens, Dec. 18, 1610, died in Paris, Oct. 23, 1688. He was educated in the Jesuits' college in his native city, and at the age of 13 spoke and wrote Greek and Latin freely. In 1631 he was admitted as an advocate before the parliament. But from that time he devoted himself to the study of history, and produced the *Glossarium ad Scriptores Mediæ et Infimæ Latinitatis* (3 vols. fol., Paris, 1678; new and enlarged edition, 7 vols. 4to, 1844). As a companion to this, he published a glossary of the impure Greek of the middle ages (2 vols. fol., 1688). Both are works of the highest value to the student of mediæval history, and to the former the Benedictines added at different times seven volumes. Du Cange also produced a *Traité historique du chef de Saint Jean Baptiste* (4to, 1665); an annotated edition of De Joinville's *Histoire de Saint Louis IX.* (fol., 1668); and *Historia Byzantina illustrata* (1680). His published works comprise but a small part of his labors. His MSS., the number and amount of which are almost incredible, have been collected and catalogued in the university of Paris. A monument was erected to him at Amiens in 1849, and a medal was struck in his honor in 1850.—See *Essai sur la vie et les ouvrages de Du Cange*, by Léon Feugère (Paris, 1852).

**DUCAREL, Andrew Colfée**, an English antiquary, born in Normandy in 1713, died in London, May 29, 1785. He was educated at Eton, and at St. John's college, Oxford, and made a journey to Normandy in 1752, which supplied materials for his "Anglo-Norman Antiquities" (4to, London, 1754; enlarged, fol., 1767). This was received with great favor, and though subsequent researches have proved the inaccuracy of some of its statements, yet it is still valued for its materials, especially its descriptions and representations of some monuments since destroyed. In 1762 he was elected a member of the royal society, and the next year he was appointed, with Sir Joseph Ayloffe, to put in order the state papers at Whitehall. He annually travelled with one of his friends during August, taking with him Camden's "Britannia" and a set of maps, and ex-

amined minutely all places of interest. Among his other publications were "A Series of more than 200 of the Anglo-Gallic Coins of the Ancient Kings of England, illustrated in 12 Letters" (4to, 1757); "The Histories and Antiquities of the Archiepiscopal Palace at Lambeth;" and numerous papers in the "Philosophical Transactions."

**DUCAS, Michael**, a Byzantine historian of the 15th century. He was a descendant of the family of the emperor Michael VII. (Ducas), and held a high position at the court of Constantine Palæologus, the last emperor of Constantinople. After the conquest of that city by Mohammed II. he took refuge with the prince of Lesbos, Dorino Gateluzzi, and by him and his successors was employed in diplomatic missions. He accompanied Domenico Gateluzzi, Dorino's son, to Constantinople, and his prudence and skill saved the independence of Lesbos. But under Nicholas Gateluzzi, the son of Nicholas, the wrath of Mohammed was called down upon the island, and it was united in 1462 to the Ottoman empire. Though Ducas survived this event, nothing more is known of his life. It is probable that he retired to Italy, and wrote in his old age the history which has come down to us. This work begins with an outline of universal chronology, and does not become detailed and truly instructive till the reign of John Palæologus I., and it terminates in the middle of a sentence at the capture of Lesbos in 1462. It is written in a barbarous style, but is judicious and impartial. It was printed at Paris in 1649, and translated into French by the president Cousin, and published in his history of Constantinople (Paris, 1672-'4), and reprinted in Holland in 1685. It was edited by Bekker at Bonn in 1834.

**DUCAT**, a gold coin, which has been long in circulation in a large part of Europe. The first ducats are said to have been struck in the 12th century in Sicily by Roger II., and to have received their name from the device inscribed upon them: *Sit tibi, Christe, datus, quem tu regis, iste ducatus*. A little later ducats of various kinds became current in Italy, and especially in Venice; and they spread thence through Switzerland, the Germanic states, Sweden, Denmark, Holland, Spain, and Russia. In Spain, however, at present, the ducat is only a money of exchange. In Germany the ducats, being made in 1559 a legal coin of the empire, soon displaced the gold florins, and generally bore the likeness of the sovereign princes. The ducats of Austria and Holland are the only ones which have acquired a very extensive circulation. Those of Holland are the most widely spread, bearing an emblem of a knight armed cap-à-pie. This emblem was for a short time exchanged for the likeness of King Louis of Holland. The value of the ducat varies somewhat in different countries, but it is about 2½ American dollars. There are also silver ducats in France and Spain, having half this value. (See COINS.)

**DUCCIO DI BUONINSEGNA**, an Italian painter, flourished in the early part of the 14th century. He was a contemporary of Giotto, and one of the celebrities of the Sienese school of painting. His masterpiece, representing the Virgin and several saints, was painted for the cathedral of Siena. Among his other works was the mosaic pavement of the cathedral, part of which remains. He also excelled as an architect.

**DU CHAILLU, Paul Belloni**, an American traveller, born in Paris, July 31, 1835. He early went to live in the French settlement at the mouth of the Gaboon, on the west coast of Africa, where his father was a merchant, became familiar with the neighboring tribes, acquired their languages, and learned much of their habits and modes of life. In 1852 he came to the United States (of which he afterward became a naturalized citizen), and soon after published in the "New York Tribune" a series of articles on the Gaboon country, which elicited much interest. In October, 1855, he sailed from New York for Africa, with the intention of making a thorough exploration of the country on the west coast between lat. 2° N. and 2° S. He spent nearly four years, until June, 1859, among different tribes, penetrating to about lon. 14° 15' E., travelling on foot, unaccompanied by any white man, upward of 8,000 miles. During this time he shot and stuffed over 2,000 birds, of which 60 were previously unknown, and killed over 1,000 quadrupeds, among which were several gorillas, never before hunted, and probably never before seen, by a white man, and 20 other species of animals previously unclassified. He returned to New York in 1859, bringing a large collection of native arms and implements and numerous specimens in natural history. After subjecting his specimens to scientific examination in several cities, he carried them to England, where many of them were purchased by the British museum. The history of this expedition was published under the title of "Explorations and Adventures in Equatorial Africa" (8vo, New York and London, 1861; new ed., enlarged, 1871). This volume is a valuable contribution to the geography, ethnology, and zoology of western Africa; but many of its statements were received with distrust, principally because they were inconsistent with the maps of Barth and Petermann. A bitter controversy arose concerning Du Chaillu's truthfulness, Prof. Gray of the British museum and others attacking his veracity with much asperity, while Prof. Owen and Sir Roderick Murchison defended him. As Du Chaillu had made his observations from compass bearings only, their correctness could not be definitively proved, and he resolved to vindicate his accuracy and his reputation by a second expedition. For this he prepared himself by a course of scientific study, learned the use of astronomical and other instruments, and acquired the art of practical photography. Meanwhile his accuracy was vindicated by

the French travellers Serval and Griffon du Bellay, who, in charge of a government expedition, explored the Ogobai river and the neighboring country in 1862. His statements concerning the Fan tribe were verified by the English traveller Burton. Du Chaillu, notwithstanding his vindication, determined to prosecute his expedition, for which he had made thorough preparation. He freighted a schooner with goods for presents to the natives, and sailed from England, Aug. 6, 1863. He reached the mouth of the Ogobai Oct. 10, and there met with a severe loss by the swamping of the canoe containing his scientific and photographic apparatus. Obligated to send to England for a new supply, he occupied his time in hunting excursions, during which he again had an opportunity of studying the habits of the gorilla. In September, 1864, his instruments having arrived, he set out for the interior, accompanied by ten Commi negroes. He revisited some of the scenes of his former explorations, took many accurate observations, and penetrated among tribes and through portions of country previously unknown. He was forced to return to the coast in September, 1865, in consequence of an unfortunate conflict with the natives, in which he lost everything but his journals. These contained all of his astronomical observations, which verified his previous statements, and added much to the geographical knowledge of western Africa. He published an account of this expedition under the title "A Journey to Ashango Land" (8vo, London and New York, 1867). After spending some years in the United States, where he appeared as a public lecturer, he visited Sweden, Norway, Lapland, and Finland in 1872-'3, returning to New York in December, 1873. Besides the above named works, Du Chaillu has written the following, intended for youth: "Stories of the Gorilla Country" (1868); "Wild Life under the Equator" (1869); "Lost in the Jungle" (1869); "My Apingi Kingdom" (1870); and "The Country of the Dwarfs" (1871). These narrate in detail incidents which had been more briefly mentioned in his two previous books.

**DU CHÂTELET, Gabrielle Émilie le Tonnelier de Breteuil**, marchioness, a French authoress, born in Paris, Dec. 17, 1706, died in Lunéville, Aug. 10, 1749. She was married at an early age to the marquis du Châtelet-Lomont, and afterward divided her time between science and dissipation. Not even a love affair with the duke de Richelieu could withdraw her from her studies. In 1733 she became the mistress of Voltaire, and the next year removed with him to Monjeu near Autun, and afterward to the château of Cirey, in which the marquis du Châtelet also resided. Here they passed several years in unrestrained freedom, actively engaged in literary pursuits, especially in the study of Newton and Locke, and the marchioness composed her *Dissertation sur la nature et la propagation du feu*, *Institutions de phy-*

*sique*, a synopsis of Leibnitz's philosophy, and various other essays. During a stay at the court of Stanislas, the ex-king of Poland, at Lunéville, she fell in love with the marquis de Saint-Lambert, by whom she had a daughter, and a few days after giving birth to this child she died in the palace of Lunéville. Several of her works were published posthumously, including *Principes mathématiques de la philosophie naturelle*, a translation of Newton's *Principia*, with a commentary (1756); *Doutes sur les religions révélées, adressés à Voltaire* (8vo, 1792); and *Lettres inédites à M. le comte d'Argental* (12mo, 1806).

**DUCHÉ, Jacob**, an American clergyman, born in Philadelphia in 1739, died there in January, 1798. He graduated at the college of Philadelphia in 1757, and completed his education at Cambridge, England. In 1759 he was ordained an assistant minister of Christ church in Philadelphia, of which in 1775 he became rector. By sermons delivered before congress and before the patriots of the army, he established his character both for eloquence and patriotism; and being in 1776 chosen chaplain to congress, he gave his salary for the relief of the families of those who had fallen in battle. But in 1777 he addressed a letter to Washington in which he pictured the hopelessness of resistance, and urged him to cease his desperate and ruinous efforts. Washington transmitted the letter to congress. Duché fled to England, and his estate was confiscated. He returned to America in 1790, but never regained influence or position. He published while in London two volumes of sermons, written in an easy and elegant style, which passed through several editions.

**DUCHESNE, André**, a French historian, born in Île Bouchard, Touraine, in 1584, died in 1640. He was geographer and historiographer to the king. On his way from Paris to his country seat he was run over by a cart and killed. Besides his published works he left more than 100 volumes in manuscript. Among the most important of the former are *Historia Normannorum Scriptores Antiqui* (fol., Paris, 1619); *Historia Francorum Scriptores* (3 vols. fol., 1636-41); and some genealogical histories.—His son FRANÇOIS, born in Paris in 1616, was also historiographer to the king, and wrote a history of the popes (2 vols. fol., 1653). He died in 1693.

**DUCHESNE DE GISORS, Jean Baptiste Joseph**, a French miniature and enamel painter, born in Gisors, Dec. 8, 1770, died there, March 25, 1856. He removed to Paris at an early age, and after the restoration of the Bourbons became court painter. His miniatures of Napoleon I. and of the duchess de Berry are remarkable specimens of the art. He was much employed by the royal families of England and Belgium, and between 1840 and 1848 was engaged in continuing the series of paintings on enamel in the Louvre commenced by Petitot. He also executed a series in enamel for Queen

Victoria after the miniatures of Sir William Ross. Some of the latter, painted in his 82d year, are of the highest excellence.

**DUCIS, Jean François**, a French poet, born in Versailles, Aug. 22, 1733, died there, March 31, 1816. His first publication was the unsuccessful tragedy of *Amélie*. He afterward adapted several of the plays of Shakespeare to the French stage with considerable success. Of his original dramatic works the best is his *Abufar, ou la famille arabe*. In the latter part of his life he wrote some shorter poems. He refused the place of senator offered him by Napoleon, though he was at the time in great poverty. His works were published in Paris in 1819, in 3 vols.

**DUCK**, a name applied to birds of the family *Anatidae*, of the order *Natatores*, and suborder *Anseres*. They have the bill large and flattened, covered with a soft epidermis rather than horn, and with its sides armed with small tooth-like processes; the tongue is fleshy, with dentated margins; the wings are moderate; the feet at or near the centre of equilibrium; the anterior toes joined by a web; the neck is long. The number of vertebræ is large, especially in the neck; the sternum and pelvis are large and wide, the former with a well developed keel, and posteriorly with two openings or deep indentations; the fibula is somewhat movable. The gizzard is fleshy and large; the intestines are about five times as long as the bird, and the cæcal appendages often one third as long as the body; the trachea and inferior larynx generally bulbous. The ducks are divided into three subfamilies. I. The *anatinae*, or river ducks, have the bill equal in width and height, depressed at the tip, which has a hard nail, and the inner portion of the lateral margins lamellated; the tarsi are compressed, and generally as long as the inner toe; the hind toe is bordered with a slight membrane from base to tip. These ducks prefer fresh water, feeding along the edges of streams, eating small mollusks and soft aquatic plants; some feed on the land, and roost and build their nests in trees; they are powerful fliers, and have a wide geographical range. In the genus  *Dafila* (Leach) is the pin-tail duck (*D. acuta*, Jenyns), having the bill lead-colored with a black spot at the tip, a long slender neck, the wing speculum of a purple or coppery red with deep green reflections and black border, the feathers with broad white tips, and a long and pointed light gray tail, dark brown in the middle; in the adult male the head, cheeks, throat, upper part of front neck, and sides are dark brown; a small part of hind neck dark green, almost black; the upper parts in general undulated with narrow bars of brownish black and yellowish white; wings grayish; upper tail coverts cream-colored; an oblique white band on the side of the neck; lower parts white, undulated like the back or the sides, and lower tail coverts black, white-edged at the side. The female and

young are variegated with brown and brownish white; the speculum is dusky green, and the long tail feathers are wanting; they are sometimes called gray ducks. The male is about 29 in. long to end of tail, extent of wings 36 in., weight about 2 lbs.; the females are smaller. It is most commonly seen on the inland ponds of the west and south of the United States from early autumn to spring, in company with teals, widgeons, and mallards; the breeding place is in the far north, in passing to and from which the birds are seen on the coast. They are very graceful on the water, rarely dive, and are less shy than most others of the family. A favorite article of food is the beech nut; they will also eat tadpoles, leeches, insects, and even dead animal matter; the flesh is much esteemed for food. Several species are found in South America, Europe, Africa, and Asia, migrating to temperate regions from the north. The typical genus *anas* (Linn.) includes the mallard or common wild duck, the origin of the domesticated species. The

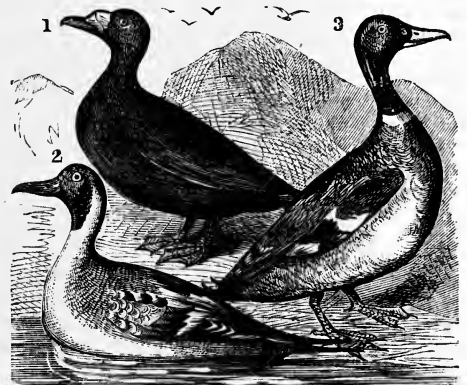

1. Scap or Broad-billed Duck (*Fulix marila*). 2. Pin-tailed Duck (*Dafila acuta*). 3. Mallard Duck (*Anas boschas*).

mallard (*A. boschas*, Linn.) has a bright purple speculum with green reflections and black border, the secondaries broadly tipped with white, and the secondary coverts with white ends and black border; the head and neck deep green, a white ring around the middle of the neck; the breast reddish brown; fore part of back light brown, the rest darker, and rump black with green reflections; upper surface of wings grayish brown; sides and lower parts pale gray with dusky bars; the length is about 24 in., extent of wings 36, and weight  $2\frac{1}{2}$  to 3 lbs.; the females are smaller, brownish, with a less brilliant speculum and the head and neck with dusky streaks. This species is smaller but more beautiful than the domestic races which have sprung from it; the wild bird may be known from the tame by its soft and pliable feet, which in the latter become hard and wider from walking over gravel and roads. The mallard is abundant from New York southward and west-

ward, being replaced to the northward, according to Audubon, by the velvet duck (*oidemia fusca*, Sw.); it is rarely seen on salt water, except when migrating. The flight is strong and rapid, easily commenced from land or water; when alarmed it utters many loud quacks. It devours anything eatable, even carrion and small animals that come in its way. Besides man, its principal enemies are hawks and owls, the raccoon, the lynx, and the snapping turtle. The flesh of the young birds is much esteemed; the large hybrids from the mallard and Muscovy duck are excellent for the table; this species also breeds with the black duck and the gadwall, the latter hybrid being very handsome, retaining the yellow feet and barred plumage of the one and the green head of the other parent. In the black or dusky duck (*A. obscura*, Gmel.) the speculum is green, with purple reflections and black border, and the secondaries are tipped with white. In shape and habit it resembles the mallard; the flesh of the young birds is excellent, and the feathers are soft and elastic. The shoveller duck (*spatula clypeata*, Boie), or spoon-bill, has the bill twice as broad at the end as at the base, much rounded, the sides at the base resembling the teeth of a fine comb; the head and neck are glossy green, upper part of breast white, rest of lower parts chestnut, except the lower tail coverts, and a black band across the vent; sides yellowish with dark pencillings; secondaries greenish, the inner with terminal white spots; primaries dark brown, with white shafts; lesser wing coverts light blue; speculum golden green; rump greenish black, white at the sides; tail dark brown, with pointed feathers broadly edged with white; length about 21 in., extent of wings 32, weight  $1\frac{1}{2}$  to  $1\frac{3}{4}$  lb. It associates with teals, mallards, and gadwalls, and is omnivorous; its flesh is much prized, and Audubon says that no sportsman who is a judge will pass a shoveller to shoot a canvas-back; it is comparatively rare, and is most common in the southern and western states. The Australian genus *malacorhynchus* (Sw.) is nearly allied to the shoveller. The Muscovy (*cairina moschata*, Flem.), more properly called musk duck, is distinguished by the red tubercle or carbuncle on the top of the bill at the base; the color is glossy black with the wing coverts white; by its lobed hind toe it connects the river ducks with the next subfamily. It is about 33 in. long; it has an odor of musk, proceeding from the coccygeal glands, which is communicated to the flesh; in its pure state it is difficult to raise, but it breeds well with the mallard, and in this domesticated state its plumage is more white, and the musky odor is absent. It is supposed to have come originally from South America, whence it has spread over the world. To the river ducks belong the genera *tadorna* (Leach), the European sheldrake, this name in America being applied to a merganser; *aix* (Boie), the wood or summer duck; *mareca*

(Steph.), the widgeon; *querquedula* (Steph.), the blue-winged teal; *nettion* (Kaup), the green-winged teal; and *chauleasmus* (Gray), the gadwall. These will be described under their respective common names. II. The sea ducks, or *fuliginæ*, have the bill higher than broad, depressed at the tip, which is armed with a broad strong nail; the wings are moderate and pointed, the tail generally short and wedge-shaped, the tarsi compressed and much shorter than the middle toe; the toes long and united by a full web, the outer as long as the middle; the hind toe short, with a deep membranous web. These ducks are generally marine, feeding on mollusks and small fish, which gives to their flesh a strong flavor; most are excellent fliers. The genus *fulix* (Sundev.) includes the scaup duck and the ring-neck. The scaup duck (*F. marila*, Baird) has the head, neck, fore part of back, and breast black, glossed with purple and green, and the last two tinged with brown; the rest of the upper parts and abdomen brownish black; the middle back, scapulars, secondaries, front of abdomen, and sides grayish white, with undulating fine black lines; middle of breast white; wings light brownish gray; speculum on the brownish black secondaries white; the length is about 17 in., extent of wings 29, and weight  $1\frac{1}{2}$  lb.; the females are brown and white. This duck, which is called broad-bill and blue-bill, is found along the Atlantic coast and also on the western rivers; it arrives from the north in October in large flocks, which at first may be easily decoyed; when wounded, it is very difficult to obtain on account of its diving, and from its fishy taste is hardly worth shooting; its flight is rapid and high. The ring-necked duck (*F. collaris*, Baird) has a tufted head, which with the upper neck is greenish black, with purple reflections; on the neck is

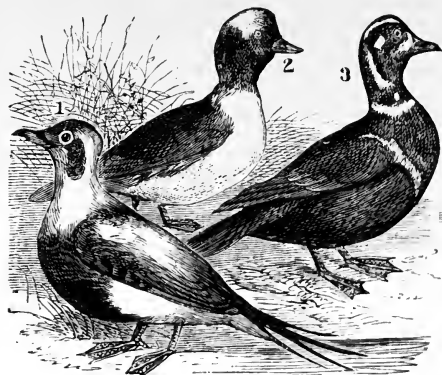

1. Old Wife (*Harelda glacialis*). 2. Buff-necked Duck (*B. albeola*). 3. Harlequin Duck (*Histrionicus torquatus*).

a brownish red ring, widest in front; a triangular white spot at the base of the lower mandible; upper parts generally brownish black, lower parts grayish white; outer secondaries

with slate-colored webs, tipped with white; tail brownish gray; the length is about 18 in., and the extent of wings 28. The female has a white band on the forehead, upper parts brownish, below white. It is met with on the coast and in the interior; it swims, dives, and flies well; its flesh is said to be excellent. Other species are found in the northern parts of Europe and Asia, and one in New Zealand; the European tufted duck is the *F. cristata*. The genus *aythya* (Boie), including the canvas-back (see CANVAS-BACK), which by some authors is put in the preceding genus, is represented here also by the red-head (*A. Americana*, Bonap.); this species has a bluish bill, black toward the end; in general appearance it resembles the canvas-back, except that the head and upper neck all round are dark chestnut, and the back is grayish brown, barred with fine white lines; the length is 20 in., extent of wings 33, and weight 2½ lbs.; in the female the head and neck are brown like the back. The red-head, like the canvas-back, is very common in the Chesapeake, but is rare north of New York; its flesh is as good as that of the canvas-back, and it is often sold for it to the inexperienced; it arrives about November, leaving for the north to breed in early spring. The genus *bucephala* (Baird) contains several well known species, among them the golden-eyed duck (*B. Americana*, Baird); this bird has a black bill, with a white spot between the base and eye; head with a crest of feathers more than an inch long; iris bright yellow; head and upper neck rich green with purple reflections; rest of neck and plumage generally white; back and wings blackish, with a patch of white on the latter formed by the secondaries and tips of the coverts; sides of rump grayish; the length is 20 in., extent of wings 31, and weight about 2½ lbs.; the female is dull brown above, white below, with dusky wings. This species arrives with the other sea ducks in the autumn from their breeding places in the north; it is found from high arctic latitudes to Florida, both on the coast and in the interior; its food consists of mollusks, crustaceans, and small fish, which it procures by diving. Its flight is strong and very rapid, accompanied by a sound which has caused this bird to be called whistler; the flesh has a fishy taste, which is relished by some; though shy and difficult to approach, it will generally alight at the decoys of the gunner on the coast. The buff-headed or spirit duck (*B. albeola*, Baird) is a miniature representative of the golden-eye; the bill is blue; the head crested; a patch behind the eye, going over the head, and band on the wings, white; rest of head and hind neck glossy green, with purple reflections; fore neck, breast, and sides pure white; abdomen dusky white; tail and upper coverts grayish brown; back and wings black, the latter with a white patch; length 14½ in., extent of wings 23, weight 1 lb.; the female is sooty brown above, breast and abdomen soiled

white, fore neck ash-colored, with a white band on the sides of the head. This duck receives its common name from the disproportionate size of the head compared with the body; from its diving habits it is also called dipper; the flight is very rapid, and its distribution extensive; its flesh is fishy. The harlequin duck (*histrionicus torquatus*, Bonap.), beautiful and singularly marked, is much prized as a cabinet specimen; the bill is yellowish olive; a broad black streak passes over the top of the head, margined with reddish brown; front of the eye and a spot behind it white; a slightly curved white line on the neck; sides of head and neck purplish blue; a complete ring of white below the middle of the neck; a band of white in front of the wing, passing on the breast, edged with black; fore back light blue, becoming black behind; scapulars white, and secondaries tipped with the same, forming a bar on the wings; fore breast light blue, abdomen brownish; quills dark brown, tail grayish black; under the tail at base a white spot; the length is 17 in., extent of wings 26½, and weight 1½ lb.; the female is grayish brown. It is rare on the coast south of Massachusetts, but common to the north, especially in the British provinces; it is shy, an excellent flier and diver, difficult to obtain, and not much prized as food. The long-tailed duck (*harelda glacialis*, Leach), called also "old wife" and "old squaw," has the bill black at the base, orange yellow at the end, with a bluish gray nail; iris carmine; a grayish white patch from the bill to behind the ear; upper part of head and nape black, narrower in front; neck all round and fore breast chocolate-brown; back and wing coverts brownish black; scapulars margined with light brown. This is the male summer plumage; in winter, the head, neck, fore back, and scapulars are white; upper parts brownish black, as are the four middle tail feathers; lower parts and the outer tail feathers white. The two median tail feathers extend several inches beyond the others; length to end of tail feathers 23 in., and extent of wings 30. The feathers are dense and blended; in the winter it is found in all the Atlantic districts; it is timid, a swift flier and ready diver; the flesh is tough and fishy. The pied duck (*camptolemus Labradorius*, Gray) has the wing coverts and secondaries white, forming a large patch on the wings; the cheeks are furnished with bristly feathers; the bill is orange at the base, black at the end, with the sides of the upper mandible very thin, and the under deeply serrated; a black band on the top of the head; rest of head and upper neck white; in the middle of neck a broad black ring, the same color passing down the back; lower neck white; upper breast and sides black; lower plumage brownish black, as are the primaries and their coverts; the length is 20 in., extent of wings 30, and weight nearly 2 lbs.; the female is bluish gray above, ash-gray below, with secondaries and sides



of head white. This species, called the skunk and sand-shoal duck, does not seem to go further south than Chesapeake bay; it is essentially marine, rarely entering rivers; it procures by diving over sand bars shell-fish and small fry; its flesh is not considered a delicacy. The genus *somateria* (Leach) contains the eider and the king duck, which will be described under the former title. The genus *oidemia* (Flem.) includes those sea ducks which are erroneously called coots in New England. The velvet duck (*O. fusca*, Sw.) has the plumage generally black, with a spot under the eye and a large patch on the wings, formed by the secondaries, white; hence the name white-winged coot; the base and sides of the bill black, the sides bright red, and the nail orange or flesh-colored; iris bright yellow; the length is 22 in., extent of wings 39, and weight about 3½ lbs.; the female is sooty brown, the lower parts lighter. These birds are seen in large flocks in autumn along

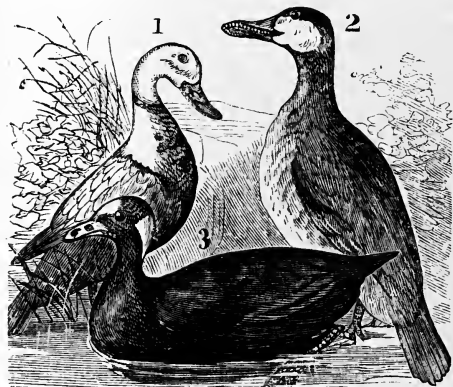

1. Pied Duck (*Camptolemus Labradorius*). 2. Ruddy Duck (*Erismatura rubida*). 3. Surf Duck (*Oidemia perspicillata*).

the Atlantic coast, when they are shot in great numbers from boats near the shore; on account of the density of the plumage they require a heavy charge to kill them; though breeding in lakes and rivers, they are rarely seen during migration away from the sea. The flesh is dark, with a fishy flavor. The surf duck (*O. perspicillata*, Linn.) has a bill of a reddish orange color, paler on the sides, with a black patch at the side of the base of the upper mandible; the plumage is black, except a white patch on the crown and hind neck; the eyes white; legs and feet reddish orange; the length is 20 in., extent of wings 33, and the weight 2½ lbs.; the female has a brownish tinge to the black plumage. This also is called coot, and associates with the preceding species, which it resembles in its habits; it is frequently called black duck; it is shy, and difficult to shoot except on the wing; the flesh is tough and fishy. The American scoter, or butter-bill coot (*O. Americana*, Sw.), has a bill of a deep orange color at the base and black at the end; the

general color of the plumage is black, bluish on the hind neck, the scapulars tinged with green; tail graduated; the length is 19 in., and the extent of wings about 32. This associates with the other species of the genus. The *O. nigra* (Flem.) is a European bird. It is probable that the American scoters, like other birds breeding in the far north, are occasionally seen in Europe. III. The spiny-tailed ducks, *erismaturinae*, have the bill elevated at the base and depressed at the tip, with a nail; the wings are short and concave, with the ends of the quills incurved; the tail is lengthened, of narrow, rigid feathers, slightly protected with coverts above and below; the tarsi are shorter than the middle toe, compressed; the toes long, united by a full web, the hind toe long, with a broad web. These ducks are short fliers from the smallness of their wings, and their geographical distribution is not extensive. In the genus *biziura* (Leach), peculiar to Australia, a large compressed wattle hangs from the lower mandible; the wings are very short, and furnished with two blunt tubercles at the shoulder. The best known species is *B. lobata* (Shaw). The ruddy duck (*erismatura rubida*, Bonap.) has a grayish blue bill, the iris hazel, and the eye situated very high up; upper part of the head black, terminating in a point behind; sides of the head white; chin with a yellowish brown tinge; upper parts and sides reddish brown; lower parts white, with dusky bars; the tail black, short, and rounded; wings blackish brown; the length is 15 in., extent of wings 22, and weight 1¼ lb. The plumage varies much at different ages. It is common in Chesapeake bay, where it is called salt-water teal; it is found all along the coast and on the Ohio and Mississippi rivers. It is an excellent diver, but is by no means shy; when young and fat the flesh is tender and of good flavor. The saw-bill ducks will be described under Merganser, to which subfamily they belong.—The domestic duck is derived principally from the mallard, mixed in some cases with the musk duck and the gadwall, and perhaps the black duck. The variety considered the best here is the Aylesbury duck, from the town of that name in Buckinghamshire, England; many thousand pounds sterling worth of ducks are sent annually to London from this place, and almost all the broods are hatched under hens, as being more certain sitters; the most prized are pure white, with pale bill and legs. The advantages of this breed are their great size and productiveness; they are early layers and good hatchers, and easily raised; besides they are ornamental, with fine, white, downy feathers, pure skin, and white, delicate, and savory flesh; at the age of 8 months a pair should weigh from 10 to 12 lbs. The large Rouen duck, originally from France, very prolific in eggs, is about 30 in. long; the back is sooty black; it is generally believed to be a half domesticated species escaped from man's restraint, and again subjected to him; it breeds readily with the

common variety. Other varieties are the Flemish crested, black and white Poland, and Silesian ducks; the musk duck is a distinct species. The Chinese rear immense numbers of ducks, which are hatched by artificial heat applied to the eggs placed in boxes of sand; they are fed with boiled crawfishes and crabs cut in small pieces and mixed with boiled rice; they are kept in boats, 300 or 400 in each, going out to feed in the morning, and returning when wanted at the voice of their master.

**DUCK HAWK.** See FALCON.

**DUCLOS, Charles Pineau**, a French author, born in Dinan, Brittany, Feb. 12, 1704, died in Paris, March 26, 1772. The first work which gained him reputation was his *Histoire de la baronne de Luz* (1741). His *Histoire de Louis XI.* was suppressed by the government in 1745. In 1750 he became historiographer of France. A collection of moral essays, entitled *Considérations sur les mœurs de ce siècle*, is the chief basis of his reputation. His writings have been collected and several times republished (10 vols. 8vo, Paris, 1806; 3 vols. 8vo, 1821).

**DUCORNET, Louis César Joseph**, a French artist, born in Lille, Jan. 10, 1806, died April 27, 1856. He was born without arms, but learned in childhood to make his feet perform all the ordinary offices of hands. He had conceived a taste for painting, and so much astonished Watteau, professor at the school of design in Lille, by the drawings which he executed with his toes, that at the age of 13 he was received into the school as a pupil. Three years later he obtained the first prize for a drawing of the human figure from nature, on which occasion his native city settled upon him a pension of 300 francs, which was increased by the government to 1,500. Pursuing his studies in Paris, he produced in 1828 his "Parting of Hector and Andromache," which he presented to the city of Lille. After the revolution of 1830 his pension was withheld. One of his last works, "Edith finding the Body of Harold" (exhibited in 1855), was painted for Napoleon III. Ducornet was not only destitute of arms, but there were certain malformations in his lower limbs which seemed to present insurmountable obstacles to the acquisition of proficiency in his art. He nevertheless used his brushes with remarkable dexterity, passing them from one foot to the other with rapidity, and making the most delicate strokes with perfect ease and accuracy. He had but four toes on each foot, but the wide space thereby left between the great toe and the next one rather facilitated the operation of painting. He was vivacious, and in an animated conversation was in the habit of gesticulating with his legs.

**DUCROT, Auguste Alexandre**, a French general, born in Nevers in 1817. After receiving his education at St. Cyr, he served for many years in Algeria, and subsequently in Italy. In 1865 he was promoted to the rank of general of division, and in 1869 was put in command of the 6th division, quartered at Strasburg. Du-

ring the ensuing war he was attached to the forces of MacMahon. In the attempt at effecting a junction with Bazaine in Metz, he was the first to reach the Meuse. On Sept. 1 he fought valiantly at the battle of Sedan, and when MacMahon was wounded he received from him the command in chief. He intended to retreat toward Belgium, but was prevented by the arrival of Gen. Wimpffen, who took command in accordance with precautionary orders brought from the minister of war. After the surrender Ducrot refused to accept the favors extended to the French officers, and was put under arrest at Pont-à-Mousson. He escaped soon after, and reaching Paris obtained command of the 13th and 14th corps, with which he fought the bloody but indecisive battles of Rueil, La Jonchère, and Buzenval. At the close of November and the beginning of December he operated with the second army in the great sorties S. of Paris and on the Marne, but failing in his enterprises, he withdrew to the woods of Vincennes. He also participated in the last and disastrous sortie of Jan. 19, 1871. After the capitulation he was elected to the national assembly, but was not reelected. In 1872 he was made commander-in-chief of the 8th army corps. In 1871 he published *La journée de Sedan, De l'état-major et des différentes armes*, and *La vérité sur l'Algérie*.

**DUCTILITY** (Lat. *ductilis*, easily led, from *ducere*, to draw), one of the specific properties of solids, which allows them to be drawn into wire or filaments. Malleability is often regarded as a modification of ductility, but the more ductile metals are not always the most malleable. Iron, for instance, is very ductile, standing near the head of the list, but its order of malleability is much lower. The following eight metals are named in the order of their ductility: gold, silver, platinum, iron, copper, zinc, tin, lead. The same metals have the following order of malleability: gold, silver, copper, tin, platinum, lead, zinc, iron. Platinum is sometimes spoken of as the most ductile metal. This is because it is practicable, by enclosing it in a cylinder of silver, drawing the two together, and then dissolving away the silver with nitric acid, to obtain a finer wire than by any other process. Wollaston obtained in this manner a wire of platinum only  $\frac{30}{100}$  of an inch in diameter.

**DUDDON**, a river of England, rises near the stones which mark the junction of Cumberland, Lancashire, and Westmoreland, flows 10 m. in a S. direction, and falls into the Irish sea by a broad estuary, forming at low tide an immense surface of land flats.

**DU DEFFAND, Madame.** See DEFFAND.

**DUDEVANT, Amanthe Lucille Aurore Dupin**, a French novelist, celebrated under the assumed name of George Sand, born in Paris in July, 1804. Her father, Maurice Dupin, died when she was scarcely four years old, leaving her to the care of her grandmother, the countess de Horn, who was the illegitimate daughter of

Marshal Saxe, the illegitimate son of Augustus II., king of Poland, and of the countess Aurora de Königsmark. She received her first education at the family country seat of Nohant, near La Châtre, where she led a somewhat eccentric life. After spending about two years at a boarding school in Paris, she returned to Nohant in 1820, and on the death of her grandmother a few months later lived with friends in the vicinity of Melun. Here she became acquainted with Casimir Dudevant, whom she married in September, 1822. The young couple took up their abode at Nohant, but found that their tempers, habits, and tastes could not harmonize, and the estrangement was embittered by pecuniary embarrassments. In 1831 Mme. Dudevant, desirous of trying her fortune as a writer, obtained permission of her husband to pass three months out of every six in Paris. She contributed a few articles to *Figaro*, but not possessing the extemporaneous facility requisite for a journalist, she found herself dependent upon the allowance of 1,500 francs paid by her husband. In order to reduce her expenses, and to visit unnoticed the public galleries, libraries, and theatres, she assumed male attire. Meanwhile she wrote a novel in conjunction with her friend Jules Sandeau, entitled *Rose et Blanche*, and bearing the name of Jules Sand, which was received favorably enough to encourage the publisher to take another from the same hands. Sandeau had nothing ready, but his associate had just completed *Indiana*, which appeared in May, 1832, under the name of George Sand, and had a brilliant success. A rumor that the author was a woman added to the interest created by *Indiana*. This was soon followed by *Valentine*, a more perfect production, which was also eagerly received. "George Sand" became then a favorite novel writer for the *Revue des Deux Mondes*. In 1833 she produced *Lélia*, which caused a profound sensation by seeming to advocate principles of infidelity and social disorder; and from this time the author was looked upon with suspicion by many of her former admirers. To recruit her health, she now started for Italy in company with Alfred de Musset, the poet; but they separated in Venice, he returning to France and she remaining and writing *Jacques, André*, and *Les lettres d'un voyageur*. On her return to France in the beginning of 1835, she met the eloquent lawyer, Michel de Bourges, who drew her into politics, Lamennais, with whom she debated questions of religion, and Pierre Leroux, who initiated her into the doctrines of socialism. Their influence was perceptible in several of her works, such as *Simon, Spiridion*, and *Consuelo*, and the continuation of the last named work under the title of *La comtesse de Rudolstadt*. The difficulties with her husband had increased, and she obtained a decree by which she was separated from him and restored to the management of her own fortune and the guardianship of her children; after which she

made Nohant a resort for her friends, and attended to her children's education. In 1838 she spent a winter in Majorca, where she was accompanied by the pianist Chopin, her relations with whom continued till 1847. In 1845 she began to write pastoral novels, including *François le Champi* (first produced as a play in 1849), *La petite Fadette*, and *La mare au diable*. The revolution of February, 1848, brought her again into the political arena, and she is said to have upheld with her pen many of the measures of Ledru-Rollin, then a member of the provisional government; but a few months afterward she returned to her country seat and her wonted occupations. In 1854 she published in the *Presse* newspaper an autobiography, entitled *Histoire de ma vie*, which contains few incidents of her life, but is a history of her mind and heart. She has published, either in book form or in journals, about 60 novels, more than 20 plays, some of which are adaptations from her novels, and many minor works. Her plays have met with less favor than her novels; but *François le Champi*, *Le mariage de Victorine* (1849), *Les beaux messieurs de Bois-Doré* (1862), and especially *Le marquis de Villemér* (1864), have been very successful. Many of her novels have been translated and published in the United States. Among her latest publications are *Journal d'un voyageur pendant la guerre* (1871), a highly interesting diary, first contributed in parts to the *Revue des Deux Mondes* during the late war, and *Impressions et souvenirs* (1873).

**DUDLEY**, a town, parish, and parliamentary borough of Worcestershire, England, but locally comprised in Staffordshire, which entirely surrounds it; pop. in 1871, 43,781. The town stands on a hill about 8 m. W. N. W. of Birmingham, and contains four churches and a number of chapels. The charitable foundations, such as free schools, infirmaries, and industrial schools, are numerous. In addition to these it has a grammar school founded in the reign of Elizabeth, many literary and scientific societies, and a museum of natural curiosities. The neighborhood furnishes abundance of coal and almost inexhaustible supplies of iron. Iron founderies, blast furnaces, and iron mills are numerous, employing many thousand persons. The chief manufactures are chains, anvils, vises, fire irons, grates and fenders, edge tools, files, nails, and agricultural implements. There are also brass founderies, glass works, brick and cement works, tanneries, and an extensive brewery. The limestone quarries of the neighborhood are remarkable. The stone is usually excavated from the solid rock, leaving vast caverns, the roofs of which are supported by limestone pillars. One of these caverns is 2 m. long, and traversed by a canal by which the stone is conveyed away. On an eminence near here are the ruins of a strong castle, said to have been built in the 8th century by Dudo, a Saxon prince. In 1644 it was garrisoned by a

body of royalists under Col. Beaumont, and held out for three weeks against the parliamentary forces.

**DUDLEY**, the name of an English historical family, descended from John de Somerie, who acquired the castle and lordship of Dudley in the reign of Henry II. The barony passed by marriage from the house of Somerie to that of Sutton in the reign of Edward II. John Sutton (Lord Dudley, died in 1487) was distinguished in the wars of the roses, and left two sons, Edward and John. A grandson of the latter was Edmund Dudley, the extortionary minister of Henry VII., who was executed for high treason under Henry VIII. (Aug. 18, 1510). His son John Dudley (1502-1553) was created Viscount L'Isle by Henry VIII. (1542), earl of Warwick by Edward VI. (1547), and after effecting the ruin of the duke of Somerset was made duke of Northumberland (1551). He persuaded the young king Edward to set aside his sisters Mary and Elizabeth from the succession, and bequeath the crown to Lady Jane Grey, who belonged to a branch of the royal family, and had married Lord Guilford Dudley, a son of Northumberland. The attempt proved a failure, and Northumberland perished with his son and daughter-in-law on the scaffold. His son Ambrose (1530-1589), usually called the good earl of Warwick, to which dignity he was restored by Elizabeth (1561), served in youth in the Netherlands, and was a distinguished ornament of the English court. He died childless.—**ROBERT**, earl of Leicester, younger brother of the preceding, the favorite of Queen Elizabeth, born about 1531, died in Cornbury, Oxfordshire, Sept. 4, 1588. He came early into the service of Edward VI., by whom he was knighted. In 1550 he married Amy, daughter and heiress of Sir John Robsart, the nuptials being solemnized in presence of the young king. In the first year of Mary he was imprisoned and condemned with his father for the attempt to transfer the succession to Lady Jane Grey; but the sentence of death was soon remitted, and he was afterward restored in blood. On the accession of Elizabeth he met with rapid preferment, his elegant and courtly address winning for him the chief place in the affections of the queen. He was made master of the horse, knight of the garter, and privy councillor, and was enabled to maintain the splendor of his station by grants of manors and castles. His intimacy with the queen was the occasion of scandal, and of a belief that he was encouraged to aspire to the hand of his sovereign. In 1560 his countess died, not without suspicion of violence, in the lonely mansion of Cumnor, in Berkshire, where she was living in retirement. In 1564 he was created baron of Denbigh and earl of Leicester, and other important offices were conferred upon him. Lady Douglas Howard, widow of Lord Sheffield, bore him a son, and claimed to have been privately married to him. In 1575 he was at the height of his power, and

entertained the queen for 17 days at his castle of Kenilworth in Warwickshire, on the decoration of which he is said by Dugdale to have expended £60,000, and the pageants and festivities were hardly surpassed in magnificence even in that splendid reign. In 1576 he secretly married the countess of Essex, immediately after she had become a widow. When this marriage was revealed to Elizabeth, she was with difficulty dissuaded from committing him to the tower. A virulent and skillfully written book against him, entitled "Leicester's Commonwealth," was published in 1584, and was many times reprinted under different titles. In 1585 he commanded the English forces in the Netherlands, and received from the United Provinces the office of captain general, and the whole control of their army and finances. This offended Elizabeth, and his ill success in the field disappointed the Hollanders. In 1586 he was called back to England to advise in the case of the queen of Scots, and recommended that she should be secretly despatched by poison; and in 1587 he returned to Holland, where his administration was so unpopular that he was soon recalled. In 1588, when the Spanish armada menaced the kingdom, he was nominated to the new office of lord lieutenant of England and Ireland; and he commanded the forces at Tilbury for the defence of the capital. He set out thence for his castle of Kenilworth, but was attacked with a violent malady, and died on the way. Notwithstanding his dissolute life, he maintained a show of respect for religion. He erected the hospital at Warwick, and gave its mastership to a Puritan divine.—**SIR ROBERT**, son of the preceding by Lady Sheffield, born in Sheen, Surrey, in 1573, died near Florence in 1639. He fitted out a maritime expedition at his own expense, with which he sailed to America in 1594, and captured some Spanish vessels. In 1596 he distinguished himself at the taking of Cadiz. On his return to England he attempted to establish his legitimacy and secure his paternal estates, but was defeated by his father's widow, the countess of Essex. He fled with the daughter of Sir Robert Southwell to Florence, and, assuming the title of earl of Warwick, was made chamberlain to the grand duchess of Tuscany and duke of the holy Roman empire. Meanwhile his estates in England were confiscated, and he was outlawed, but at the Tuscan court his honors increased. By draining a vast morass between Pisa and the sea he made Leghorn a large and beautiful town. He improved its harbor, caused the grand duke to declare it a free port, drew many English merchants to settle there, and having received a liberal pension, built a noble palace in the capital, and beautified his country seat of Carbello, three miles from Florence. He was the author of several works, the best known of which is *Dell' arcano del mare*, a remarkable collection of tracts relating to commerce and navigation (Florence, 1630, 1646; there is a copy in the

British museum dated 1661).—The castle of Dudley belonged to the family of Sutton till in 1697 it passed by marriage to that of Ward. John Ward (died in 1774) was created (1763) viscount of Dudley and Ward, and this viscounty continued till it became extinct at the death of John William Ward (1781–1833), who entered the house of commons in 1802, and became secretary of state under Canning.

**DUDLEY**, the name of several royal officers of Massachusetts. **I. Thomas**, governor of the province, born in Northampton, England, in 1576, died in Roxbury, Mass., July 31, 1652. In 1630 he came to Massachusetts with the commission of deputy governor, and he was governor from 1634 to 1640, and again from 1645 to 1650. He was a man of integrity and piety, though intolerant. **II. Joseph**, governor of the province, son of the preceding, born Sept. 23, 1647, died in Roxbury, April 2, 1720. He graduated at Harvard college in 1665, served in the Indian war in 1675, was sent to England as agent for the province in 1682, appointed president of New England in 1685, superseded by Andros a few months later, and made chief justice in 1687. He went to England again in 1689, was chief justice of New York from 1690 to 1693, then eight years lieutenant governor of the Isle of Wight, and finally governor of Massachusetts from 1702 to 1715. He was a man of high moral character, and a scholar.

**III. Paul**, chief justice of the province, son of the preceding, born Sept. 3, 1675, died in Roxbury, Jan. 21, 1751. He graduated at Harvard college in 1690, studied law in London, and returned to Massachusetts in 1702 with the commission of attorney general. In 1718 he was appointed judge, and in 1745 became chief justice. He bequeathed £100 to Harvard college for the support of an annual lecture. This lecture is called from its founder the Dudleian lecture, and, according to the direction of the founder, is delivered on one of four subjects which are treated of in succession. The first of these is natural religion; the second, the Christian religion; the third, the errors of the Roman Catholic church; and the fourth, to explain and maintain the validity of the ordination of ministers according to the ancient custom in New England. He was a fellow of the royal society, and besides 12 treatises, chiefly on natural history, in the "Philosophical Transactions," published a work against the church of Rome.

**DUDLEY, Benjamin Winslow**, an American surgeon, born in Spottsylvania co., Va., in 1785, died at Lexington, Ky., Jan. 20, 1870. He received his education at Transylvania university, Lexington, Ky., and took his medical degree at the university of Pennsylvania in 1806. In 1810 he went to Europe and studied four years under the most eminent physicians. On his return he settled in Lexington, Ky. He operated for stone in the bladder 207 times and lost only five patients, and had occasion to repeat the operation in but one instance. He

also successfully applied a ligature to the carotid artery for aneurism within the skull, where trephining had been tried by another surgeon for supposed water on the brain. He retired from active practice in 1854. He published several medical essays, and on the organization of the medical school of Transylvania university became professor of surgery.

**DUDLEY, Charles Edward**, an American senator, born at Johnson Hall, Staffordshire, England, May 23, 1780, died in Albany, N. Y., Jan. 23, 1841. After the death of his father he came with his mother to Newport, R. I., in 1784. He entered into trade in that town, and made at least one voyage to the East Indies as supercargo. He subsequently removed to New York, where in July, 1809, he married Blandina, daughter of Rutgers Bleecker. Two years later he removed to Albany. He was elected state senator for three successive terms in 1820–25, mayor of the city in 1821 and 1828, and in 1829 United States senator to serve out the unexpired term of Martin Van Buren. He was particularly fond of astronomical science, and his widow contributed \$70,000 to the erection and endowment of the Dudley observatory. (See ALBANY.)

**DUDWELLER**, or *Duttweiler*, a town of Prussia, in the province of the Rhine, 10 m. N. E. of Saarbrück; pop. in 1871, 8,920. Near it are large coal mines.

**DUEL**, a premeditated combat between two persons, with deadly weapons, for the purpose of deciding some special difference. Single combats are of ancient date. Many are recorded in the Iliad; and the story of David and Goliath shows that duels were known to the Hebrews and other Asiatics, as they were also to the Arabs of the time of Mohammed. T. Manlius Torquatus fought with a gigantic Gaul in the war of 361 B. C. The barbarians who overran the Roman empire gave to single combats a new character, starting with the idea that the wager of battle is an appeal to the decision of God, and that success is a proof of right; hence the ordeal was accompanied with religious solemnities. Tacitus mentions it among the Germans, and it was formally legalized by Gundebald, king of the Burgundians, about 500. During the middle ages duels multiplied greatly, and as a judicial ordeal were approved by jurists and churchmen, and patronized by monarchs. The laws of the time show the excessive prevalent abuse of the ordeal. By the truce of God of 1041, duels were not permitted between Wednesday and Monday, the days intervening being sacred to Christ's passion. Louis IX. tried to restrain duels, and succeeded in reducing their number. Philip the Fair framed laws against them in 1296 and 1303, but in 1306 allowed them in criminal cases which could be reached in no other way. In 1315 Louis X. restored the judicial ordeal in civil cases. In 1386 Jacques Legris was accused of violence to a lady. He denied the crime, was forced to the

ordeal of battle, was overcome, and being adjudged guilty was hanged, but subsequently another person confessed that he was the criminal. This made a profound impression, and caused the abolition of the judicial ordeal. It was not formally abolished in some other countries for many years; but from this time it practically ceased.—The duel is no longer an appeal to the judgment of God, but is an attempt to secure satisfaction for an injury, especially for an insult. This idea owes its prevalence largely to Francis I., who laid down the principle "that the lie was never to be put up with without satisfaction, but by a base-born fellow;" and lies were divided into 32 classes, each having its own mode of satisfaction. Duelling at this time became a custom in France, whence it spread all over Europe, becoming especially popular in England and Ireland. In 1560 the states general prayed Charles IX. to punish duelling, and he issued an ordinance, which is the basis of the laws of Henry IV. and Louis XIV. This law, however, was ineffective. When Henry III. died, one of his courtiers, L'Isle Marivaux, swore not to survive him, and threw a challenge into the air; another lord picked it up, and sent him to join his master. Henry IV. fought not in person but by deputy, although he was constrained to legislate against duelling in 1602. But he practically nullified his law by granting thousands of pardons. Duelling in France reached its height under Louis XIII. Two gentlemen held each the other's left hand, and with the right stabbed each other with daggers. Two others in a close room cut each other's throat. In this reign several edicts were issued against duelling, and, thanks to Richelieu, were not a dead letter, as was seen in the beheading of François de Montmorency, count de Bouteville, in 1627. Louis XIV. opposed duelling, and lessened its frequency. Under the regency it revived, and Louis XV. could do little against it. Saint-Evremond and Saint-Foix, and especially the duke de Richelieu, were noted duellists. Under the next reign there were many duels, one of the most famous being that of the count d'Artois, afterward Charles X., with the duke de Bourbon-Condé. The first tendency of the revolution was to suppress duelling. It was looked upon as aristocratic, and the life of every man was said to belong to his country. When the reaction commenced duelling was revived, because of the ascendancy of the military class. Napoleon was averse to duelling, but had to tolerate it, even while expressing his contempt for duellists. The most celebrated duels in France since the revolution were between Gen. Gourgaud and Count Ségur, Col. Pepe and Lamar-tine, Bugeaud and Dulong, Armand Carrel and Émile de Girardin (in which the former lost his life), Thiers and Bixio, and Proudhon and Félix Pyat. Since 1837 duellists and their seconds are liable to the criminal law in France

for any homicide resulting from the duel, but much discretionary power is left to the prosecuting magistrate. There have been female duels in France; a celebrated one was fought under the regency between Madame de Nesle and the countess de Polignac, for the possession of the duke de Richelieu. Duelling is still common in France, having raged in the latter part of the second empire chiefly among journalists.—In Spain the duel, though common, has been less frequent than in France. Charles V. issued an edict in 1519 for its suppression, but his conduct in his dispute with Francis I. nullified his edict. On March 12, 1870, Prince Enrique de Bourbon, brother of the king consort and infante of Spain, was killed in a duel with the duke de Montpensier.—Duels were favored by the northern races. In Denmark women were not allowed champions as in other countries, but were compelled to do their own fighting, though certain advantages were permitted them. In Norway this species of combat was held in high honor, but in Sweden it was nominally forbidden under severe penalties. Gustavus Adolphus was especially opposed to duelling, and once prepared a gallows for that party who should survive a particular combat; yet he offered the "satisfaction of a gentleman" to an officer whom he had struck. In Germany duelling is much less in vogue than in France, excepting among students in the universities. In Austria the ancient laws inflicting long imprisonment upon those who kill or maim their antagonists are still in force. Tribunals of honor for military men have existed in Prussia since 1843, for reconciling the contending parties when it can be done without prejudice to the military code of honor. If reconciliation is impossible, the duel takes place; if no injury is done, the imprisonment never exceeds six months; and if it prove fatal, never more than four years. Among the students of the German universities duels are fought with swords, and the combatants wear a complete defensive armor, consisting of thickly padded gauntlet and breastplate, the head and face only being exposed. These duels are rarely fatal, but often result in disfiguring cuts on the head and face. Russia has known little of the duel; but Russians have shown a readiness to fight in single combat quite equal to their steadiness in the battle field. The Poles have proved themselves stanch duellists, and the judicial combat was frequent in independent Poland. The Netherlands have closely imitated France, both in duelling and in attempts to suppress it.—It has been asserted that single combats were introduced into England by the Normans. They are said to have instituted the wager of battle, from which duelling proceeded, and which it is believed was unknown to the Saxons. Yet Lappenberg asserts that "William the Conqueror speaks of the judicial combat as a known English custom." It was not formally abolished until the last year of the reign of George III.; and as late as 1774 it

was defended by some of the greatest men of England. In the reign of James I. there were many duels, one of the most noted of which was between Lord Bruce and Sackville, afterward earl of Dorset, in which the former was killed. A sermon delivered by Chillingworth before Charles I. contains a warm expostulation against duelling. Cromwell was a foe to the practice. After the restoration it became more common, from the spread of French ideas. Some of the English duels of that time were in keeping with its loose morality. The duke of Buckingham killed Lord Shrewsbury; Lady Shrewsbury, on whose account the duel was fought, attending the duke as a page, and then passing the night with her lover. In Anne's reign, the duel between the duke of Hamilton and Lord Mohun, in which both fell, caused much feeling, from its political character, and the atrocities that marked it. Duels became more numerous as society became more orderly, and many of the most distinguished Englishmen took part in them. William Pulteney, leader of the opposition, fought Lord Hervey. Wilkes was engaged in two duels. Throughout the reign of George III. duels were frequent; among those who fought in England were Charles James Fox, Sheridan, Pitt, Canning, Castlereagh, the duke of York, the duke of Richmond, Sir F. Burdett, and Lord Camelford; the last named was the great duellist of the time, and fell in a duel in 1804. During the reigns of George IV., William IV., and Victoria, there were some noted duels, among which was that between the duke of Wellington and Lord Winchelsea, in 1829, the duke challenging the earl because of the latter's reflections on his conduct at the time he determined upon emancipating the Roman Catholics. The duke fired at his antagonist, who fired in the air, and then apologized. In 1835 Benjamin Disraeli challenged Morgan O'Connell. Among the most conspicuous duels in England of late years was that between the earl of Cardigan and Capt. Tuckett in 1840.—Ireland is that part of the British empire in which duelling has always been most in vogue. In the latter part of the last century there was scarcely an Irishman of note who had not been "out," and many of them had fought often. Grattan, Curran, Lord Clare, Flood, Burrowes, Barrington, Toler, and many others, men of high positions, were among the Irish duellists of those times. In 1815 Daniel O'Connell fought with and killed Mr. D'Esterre, a member of the Dublin corporation, which the former had stigmatized as a "beggarly" body. In Scotland duels have not been so common as in Ireland. In 1822 James Stuart, known by his work on the United States, killed Sir Alexander Boswell in a duel, which grew out of gross newspaper attacks on the former. Stuart was tried and acquitted. Francis Jeffrey, who was of counsel for the defence, went almost the entire length of upholding duelling, and boldly assumed that

the man who slew another under the circumstances that caused Stuart to slay Boswell was not guilty of murder in any sense. The court, while it charged that killing in a duel was murder, declared that there was no evidence of malice on the part of Stuart, and praised his conduct on the ground; and when the acquittal was given, the court congratulated him on the result. It is a singular fact that Boswell, when a member of parliament, took the principal part in getting two old Scotch statutes against duelling repealed, one of which made the mere fighting of a duel, though it should have no evil result, punishable with death.—The first duel in America took place in 1621, at Plymouth, between two serving men. They were sentenced to be tied neck and heels together for 24 hours, but a portion of the punishment was remitted. In 1728 a young man named Woodbridge was killed in a duel on Boston common, by another young man named Phillips. They fought without seconds, in the night and with swords. Phillips got on board a man-of-war and escaped to France. A great sensation was caused, and a new and severe law against duelling was enacted. There were some duels in the revolution, the most noted being those between Charles Lee and John Laurens, in which the former was wounded, and between Cadwalader and Conway, in 1778, in which the latter received a shot in the head from which he recovered. Button Gwinnett, one of the signers of the Declaration of Independence, was killed in a duel with Gen. McIntosh, in May, 1777. In 1785 Capt. Gunn challenged Gen. Greene twice, and threatened a personal assault when the latter refused to meet him. Greene wrote to Washington, acknowledging that if he thought his honor would suffer from his refusal he would accept the challenge. Washington approved of his course. Alexander Hamilton was killed in a duel with Aaron Burr in 1804, the latter being vice president and the former the leader of the opposition. This duel is allowed the first place in the history of American private combats. Next stands that between Capts. Barron and Decatur, the latter being killed and Barron severely wounded. Henry Clay and John Randolph fought in 1826. Andrew Jackson killed Charles Dickinson in a duel, and was engaged in other "affairs." Thomas H. Benton killed a Mr. Lucas, and had other duels. In 1841 Henry Clay was on the eve of fighting with William R. King, then a senator from Alabama. Mr. Cilley of Maine fought with Mr. Graves of Kentucky in 1838, near Washington, and the former was killed. This duel caused nearly as much excitement as that between Hamilton and Burr. Both parties were members of congress. Formerly duels were very common in the United States navy, and valuable lives were lost. Richard Somers, who is said to have been a mild man, fought three duels in one day. In 1830 President Jackson caused the names of four officers to be struck

from the navy roll because they had been engaged in a duel. In the northern states public opinion has always been against duelling; yet at the beginning of the century duelling was common there, and several duels were fought in New England, while the "code of honor" was in full force in New York and New Jersey. Five shots were exchanged between De Witt Clinton and John Swartwout in 1802; and a challenge passed between Mr. Clinton and Gen. Dayton of New Jersey in 1803. Duels have been not infrequent in the different parts of British America.—By the common law, when one of the parties to a duel is killed, the survivor and the seconds are guilty of murder; and the participation in a duel, either as principal or second, where there is no fatal result, is regarded as a misdemeanor. Many of the states have modified this rule; in some the killing of a man is punishable with death, in others a term of imprisonment with forfeiture of political rights is substituted. Some states require certain officers of state to make oath either that they have not within a certain time been, or will not be, concerned in a duel; and in nearly all the duellist and his abettors are disqualified from holding office or exercising the elective franchise for life, or for a term of years, according to the issue of the duel. In the American naval and military service, an officer implicated in a duel with another, either as principal or second, is liable to be cashiered; and an equally stringent provision exists in the British service.—See J. G. Millingen, "The History of Duelling" (2 vols., London, 1841); Lorenzo Sabine, "Notes on Duels and Duelling, with a preliminary Historical Essay" (12mo, Boston, 1855).

**DUER, John**, an American jurist, born in Albany, N. Y., Oct. 7, 1782, died on Staten island, Aug. 8, 1858. He was the son of Col. William Duer of the revolutionary army, and on his mother's side a grandson of Gen. William Alexander, the claimant of the Scottish earldom of Stirling. In his 16th year he entered the army, but after two years left the service for the study of law. He commenced practice in Orange co., N. Y., whence about 1820 he removed to the city of New York, where he resided until his death. In 1825 he was appointed one of the commissioners to revise the statute law of the state, and afforded valuable assistance in the preparation of the first half of the work. In 1849 he was elected a justice of the superior court of New York city, and in 1857 he became the presiding justice of the court. In 1845 he published a "Lecture on the Law of Representations in Marine Insurance," and in 1845-'6 a treatise on the "Law and Practice of Marine Insurance" (2 vols. 8vo), which has become a standard authority in the United States. In 1848 he delivered a discourse on the life of Chancellor Kent, and at the time of his death was editing "Duer's Reports" on the decisions of the superior court. The 6th volume, which he

did not live to complete, he revised while confined to his bed by a fracture of the thigh.

**DUFAURE, Jules Armand Stanislas**, a French statesman, born at Saujon, Dec. 4, 1798. He studied at Paris, practised law at Bourges, was elected deputy for Saintes in 1834, and was continually reelected till 1848, acting with the liberal constitutional party, and exercising great influence, especially in regard to public works and finances. He was nominated councillor of state by Thiers in 1836, and became minister of public works in 1839 under Soult, but vacated his office in the following year on the return of Thiers to power. In 1844 he was elected vice president of the chamber, and after the revolution of February, 1848, a member of the committee on the constitution, and minister of the interior under Gen. Cavaignac. Under the presidency of Louis Napoleon he held the same office for a short time in 1849, and after the *coup d'état* he retired to private life. In 1871 Thiers appointed him minister of justice, and a special decree conferred on him the vice presidency of the council of ministers, which offices he lost on the accession of MacMahon in 1873.

**DU FAY, Charles François de Cisternay**, a French savant, born in Paris, Sept. 14, 1698, died July 16, 1739. He made new researches concerning phosphorus, the barometer, the refracting power of crystals, the magnet, and electricity. He introduced the theory of two kinds of electricity, the vitreous and the resinous. He spent ten years in rearranging and improving the *jardin des plantes*, and made it the first establishment of the kind in Europe.

**DUFF, Alexander**, a Scottish missionary, born near Pitlochrie, Perthshire, about 1806. He entered the university of St. Andrews at the age of 15, and while a student became intimate with Dr. Chalmers. In the summer of 1829 he was licensed to preach. During the later years of his academical studies he was the associate of John Adams and John Urquhart, afterward known in connection with missions. These young students spent much of their leisure time in visiting the poor, distributing tracts, and conducting prayer meetings and Sunday schools in destitute parts of the surrounding country. The churches in Scotland had not yet undertaken any mission to the heathen. When a mission to India was resolved upon, Mr. Duff was selected as the first missionary, and he set sail toward the close of 1829. During his voyage he was shipwrecked on a reef while rounding the cape of Good Hope, and again on the coast of Ceylon. By the first of these mishaps he and his wife lost everything that belonged to them; his plans of operation, his library, and papers were all lost. In India he was kindly received, but not encouraged by his countrymen. Rammohun Roy, however, who had considerable influence over the natives, entered warmly into the views of Duff, and with his assistance a school was commenced under a banian tree



with five young men. The shade of the banian was soon too narrow. The studies of the school were accompanied with the daily reading and exposition of the Scriptures. The value of Mr. Duff's labors was very soon apparent both to the native population and their British rulers. His honesty, perseverance, and zeal, in connection with his varied gifts and talents, soon gave a commanding influence to him and the Scottish college which he had established, which ultimately became the largest institution of its kind in India. When intelligence of the disruption of the church of Scotland in 1843 reached Calcutta, Dr. Duff and his brethren at once and unanimously declared their adherence to the Free church, and vacated their institution, with all its valuable library and apparatus. Dr. Duff returned to Europe in 1851 to recruit his health; but he entered on the revival of the missionary spirit among the British people, visiting the churches even in the remotest British isles. In 1854 he made a voyage to America, visited the principal cities in the northern and western states, and passed through Canada. In 1855 he returned to India, but finally left it in 1863 on account of ill health, and was made professor of evangelistic theology by the general assembly. An endowment of £10,000 had been raised for this professorship, but he refused to accept any salary, stipulating that the income should be given to the cause of missions. He has published "New Era for the English Language and Literature in India" (Edinburgh, 1837), "India and India Missions" (1839), and "Letters on the Indian Rebellion" (1858).

**DUFFERIN, Frederick Temple Hamilton Blackwood**, earl of, an English statesman and author, son of the fourth Baron Dufferin and Helen Selina, granddaughter of Richard Brinsley Sheridan, born June 21, 1826. He was educated at Eton, and at Christchurch, Oxford. He succeeded his father July 21, 1841, as fifth Baron Dufferin and Clandeboye, and was made baron of the United Kingdom in 1850. In 1860 he was sent by Lord Palmerston as British commissioner to Syria, to inquire into the massacre of Christians there. In October, 1862, he married Harriet Georgina Hamilton, who is distinguished as the author of "The Hon. Impulsia Gushington," a lively satire illustrated from her own drawings, describing the tour of a fashionable lady in Egypt. He was under secretary of state for India 1864-'6, and for war 1866-'7; was made chancellor of the duchy of Lancaster in 1868; was created Viscount Clandeboye and earl of Dufferin in November, 1871; and was appointed governor general of the Dominion of Canada June 1, 1872. He is the author of "Letters from High Latitudes," a narrative of a yacht voyage to Iceland in 1859 (London, 1860), a new and enlarged edition of which was published at Montreal in 1873.

**DUFFY, Sir Charles Gavan**, an Irish politician, born in Ulster in 1816. He is the son of a

farmer, became a journalist at the age of 18, and for several years edited a newspaper at Belfast. While thus engaged he studied law and was called to the bar, but never practised. In 1842 he established the "Nation" in Dublin, a publication strongly in the interest of O'Connell and the advocates of repeal of the union; and in 1844 he was imprisoned with O'Connell and the prominent repealers. In 1848 he was tried with Smith O'Brien, Thomas Francis Meagher, and others, for sedition, but was acquitted. He then revived the "Nation," which had been suspended, and advocated various social reforms for Ireland, and between 1852 and 1856 represented New Ross in parliament. In the latter year he emigrated to Australia, where he has been a member of the colonial legislature, and of the ministry. In 1871 he became prime minister of the colony, and in 1873 was knighted. He is the author of "Ballad Poetry of Ireland."

**DUFOUR, Guillaume Henri**, a Swiss general, born in Constance, Sept. 15, 1787. He was educated in Geneva and Paris, entered the French army, obtained a commission in 1809, served in the last campaigns of Napoleon, and distinguished himself during the hundred days. When Geneva was restored to Switzerland, he became a citizen of the republic, and in 1831 was made chief of the staff of a corps destined to defend its neutrality. He was intrusted with the management of the military school at Thun, and with the survey of Switzerland. When the organization of the Sonderbund, and the apprehended intervention of foreign powers, seemed to threaten the existence of the confederation in 1847, he was chosen commander-in-chief of the federal forces, and rapidly suppressed the civil war. In 1864 he was president of an international council in regard to the treatment of the wounded, which resulted in the convention of Aug. 22 between 12 European states. He is the author of *De la fortification permanente* (1824), *Géométrie perspective*, &c. (1827), *Mémoires sur l'artillerie des anciens et sur celle du moyen âge* (1840), and *Manuel de tactique* (1842).

**DUFOUR, Léon**, a French naturalist, born about 1782, died at St. Sever, Landes, in April, 1865. He studied medicine at Montpellier, and after taking part in the Spanish campaign of 1823 as army physician, he settled in St. Sever. Besides numerous articles scattered in periodical publications, he wrote *Relation de voyage dans les montagnes maudites* (1821); *Recherches anatomiques et physiologiques sur les hémiptères* (4to, 1833); *Essai sur quelques points de l'état actuel de la physique et de la chimie* (1853); *Propriétés des végétaux et leurs applications à l'alimentation, la médecine, la teinture*, &c. (1861).

**DUFRENOY, Pierre Armand**, a French geologist and mineralogist, born at Sevrans, Seine-et-Oise, in 1792, died in Paris, March 20, 1857. His mother Adelaide (1765-1825) was a poetess of merit. His first essay appeared in

1819, and was followed by a great variety of papers on mineralogy and geology, which gained him a high reputation. His explorations in southern France and in the Pyrenees led him to develop the theory of metamorphism. He explored the vicinity of Naples, and in his essay entitled *Des terrains volcaniques des environs de Naples* he maintains that Herculaneum and Pompeii were destroyed by a landslide from Vesuvius. With Élie de Beaumont he explored between 1823 and 1836 various parts of France, England, and northern Spain, the principal result of which was the great geological map of France, with 3 vols. of text, published in 1841. Another product of their common labors was the *Voyage métallurgique en Angleterre* (2 vols. 8vo, 1827; enlarged ed., 1837-'9). (See ÉLIE DE BEAUMONT.) He was one of the most active members of the academy of miners, director of the school of mines, and professor of mineralogy and geology. He introduced a new classification of minerals based upon crystallography, promoted in various other ways the study of mineralogy and meteorology, and published a *Traité de minéralogie* (2d ed., enlarged, 4 vols. 8vo and 1 vol. of plates, Paris, 1856-'9).

**DU FRESNE, Charles.** See DU CANGE.

**DUFRESNOY, Charles Alphonse**, a French painter and poet, born in Paris in 1611, died at Villiers-le-Bel, near Paris, in 1665. His pictures are correct, but not otherwise remarkable, and he is now chiefly remembered as the author of a Latin poem entitled *De Arte Graphica*, which has been translated into French by Roger de Piles, and by several since him, and three times into English, viz.: into prose by Dryden (4to, London, 1695) and by Wills (4to, 1754), and into verse by William Mason, with notes by Sir Joshua Reynolds (4to, York, 1783).

**DUFRESNY, Charles Rivière**, a French dramatist, born in Paris in 1648; died there, Oct. 6, 1724. He was descended from Henry IV. by one of the mistresses of that monarch, known as *la belle jardinière*. He enjoyed the favor of Louis XIV., wrote some excellent comedies, and had great skill as a landscape gardener. Among his most successful comedies are *L'esprit de contradiction*, *La coquette de village*, and *Le faux sincère*. His *Poésies diverses* are also praised. A selection of his works was published at Paris in 2 vols. in 1810.

**DUGDALE, Sir William**, an English antiquary, born in Shustoke, Warwickshire, Sept. 12, 1605, died there, Feb. 10, 1686. He was educated partly in the free school of Coventry, partly by his father, was made pursuivant at arms extraordinary under the title of Blanch Lyon in 1638, became garter principal king at arms in 1677, and was knighted. In 1641 exact drafts of all the monuments in Westminster abbey and in many of the churches of England, with copies of their inscriptions, were made under his superintendence and deposited in Sir Christopher Hatton's library. With Roger Dods-

worth he projected the publication of the charters and descriptions of all the monasteries of the kingdom; and he collected from the Bodleian and other Oxford libraries, from the tower records, the Cottonian library, and the papers of André Duchesne, materials for the work, the first volume of which, in Latin, was published in London in 1655, under the title of *Monasticon Anglicanum*; vols. ii. and iii. were issued in 1661 and 1673; a new enlarged and illustrated edition, in 6 vols. crown folio, was published in 1817-'30. This edition was reprinted at London in 8 vols. fol. in 1846. Several abridgments of the work have been made in English. Among Dugdale's other contributions to history are the "Antiquities of Warwickshire" (fol., 1656), one of the best works of the kind ever published; "History of St. Paul's Cathedral" (fol., 1658); "History of Imbanking and Draying of divers Fenns and Marshes" (fol., 1662); "*Origines Juridicales*, or Historical Memoirs of the English Laws, Courts of Justice, Forms of Trial, Punishment in Cases Criminal, Law Writers," &c. (1666); "The Baronage of England, or an Historical Account of the Lives and most memorable Actions of our English Nobility" (3 vols. fol., 1675-'6); "A Short View of the late Troubles in England" (Oxford, 1681); "Ancient Usage in bearing of such Ensings of Honor as are commonly called Arms" (Oxford, 1681); "A Perfect Copy of all Summons of the Nobility to the Great Councils and Parliaments of this Realme, from the XLIX. of Henry the III. until these present Times" (London, 1685). Dugdale also completed the 2d volume of Sir Henry Spelman's *Concilia*. His "Life, Diary, and Correspondence," with an index to his MS. collections, many of which are preserved in the Ashmolean museum at Oxford, was published at London in 1827 by William Hamper.

**DUGONG**, a herbivorous cetacean, of the genus *dugungus* (Lacépède) or *halicore* (Illiger), the only genus of its family, and the only undisputed species of the genus; the Malay name is *duyong*, and the scientific *halicore Indicus* (Desm.) or *H. dugung* (F. Cuvier). The general shape is fish-like; the head is small in proportion to the body, and separated from it by a slight cervical depression; there is no dorsal fin, and the horizontal tail is crescent-shaped; there are no posterior limbs, but the anterior are like cetacean paddles without any trace of nails or division into fingers. The upper lip is very large, thick, obliquely truncated, forming a blunt snout such as would be made by cutting off an elephant's trunk near the mouth; the anterior portion is covered with soft papillæ, with a few stiff bristles; the lips have a corneous edging which assists it in tearing sea weeds from the bottom. In the old animal the incisors are two above and none below, large, but nearly covered by the tumid and movable lip; in the young, the upper permanent incisors are preceded by two deciduous ones, and there are six or eight lower incisors

which fall and are not succeeded by permanent ones. The molars in the adult are  $\frac{3}{2}$ - $\frac{3}{2}$ , simple and elliptical, in the young  $\frac{4}{2}$ - $\frac{4}{2}$ , far back on the horizontal portion of the jaw; the grinding surface presents an outer rim of enamel, with the central ivory portion slightly depressed; they have no proper roots, and grow as long as they can be of use to the animal. The skin is thick and smooth, with a few scattered bristles; the color is bluish above and white beneath; the mammae are two, and pectoral; the fins are used not only for swimming, but for crawling along the bottom. The cranial bones are dense and large, with loose connections where any sutures exist. The intermaxillaries are very large, extending back as far as the middle of the temporal fossæ, and bent down at a right angle over the symphysis of the lower jaw, terminating nearly on a level with its lower margin; this is necessary for the accommodation of the incisors, one of which is in each intermaxillary; for this reason also the nostrils are displaced upward, dif-

dals about 24, with chevron bones for the anterior three fourths, and becoming flattened posteriorly. The ribs are 18, less thick and dense than those of the manatee, the first 3 attached by cartilages to the sternum; the shoulder blade is large, with the anterior angle rounded, the posterior extended backward with a concave margin; the spine is prominent, and the acromion and coracoid processes are pointed; the humerus is short, thick, with a prominent deltoid ridge; the radius and ulna are very short, rounded, ankylosed at each end; the carpal bones are 4, in two rows; the thumb is rudimentary, its metacarpal bone small and pointed; the other metacarpals are flattened, with three-jointed phalanges. The tongue is thick, the anterior upper surface with cuticular spines, and on each side at the base a horny, retroverted, pointed process. The stomach is divided into two portions, the cardiac large and globular, the pyloric narrower; at the constriction between the two are two tubular caecal prolongations as in some pachyderms, and at the cardiac end is a rounded glandular mass as in some rodents; the intestines are 14 times as long as the body, and the caecum is simple and heart-shaped. The liver is transversely oblong, with one large and three small lobes; the gall bladder is present, elongated, receiving bile directly from the hepatic ducts; the spleen is very small and rounded. The heart has its ventricles deeply cleft, but not affecting the circulation; the capacity of the pulmonary artery is very great, to accommodate the delay of the blood in the lungs during submersion. The lungs are very long, flattened, one fourth as long as the body; the superficial air cells are large, the dorsal extent is great, the trachea divides high up, and the bronchi are long, as in marine turtles; the cartilages of the bronchial tubes are continued spirally into each other. The sense of smell must be dull; the eye is very small and convex, with a nictitating membrane beside the lids; the external orifice of the ear is hardly perceptible; the nasal openings are two parabolic slits, whose semilunar edge acts as a valve; the interior of the cheeks, according to F. Cuvier, is entirely covered with strong hairs. The usual length of the dugong is from 8 to 10 ft., though it has been seen as long as 20 ft.; it is found in the seas of the East Indies, especially in the Malayan archipelago, never on land, rarely if ever in fresh water, but generally in troops where the depth is not more than three fathoms. Its food consists of fuci and algæ, and it browses on the marine vegetation as a cow does on land. It yields little or no oil, but is hunted by the Malays for its flesh, which resembles young beef, and is tender and palatable. It is generally speared, and at night, especially during the northern monsoon, at the mouths of rivers, when the sea is calm. The affection of the mother for her young is very remarkable. In the Red sea is a species called *H. tabernaculorum* by Rüppell, from his be-



Dugong.

ferent from the allied manatee, so that their opening is turned up as in the typical cetacea; indeed, this animal comes nearer than its congener to the whales in its forked tail, absence of nails, and superior opening of the nostrils. The whole skull (and especially the frontal bones) is comparatively short; the parietal crests are widely separated; there is no bony tentorium, no sella turcica, very few and small openings in the cribriform plate of the ethmoid bone, and the optic foramina are converted into a long and narrow canal. The lower jaw corresponds to the angle of the intermaxillaries, and is bent downward at the symphysis; on its anterior surface are three or four rough and shallow alveoli, sometimes containing rudimentary incisors. The cervical vertebrae are 7, separate; the dorsals 18, with spinous processes bent back and elongated from the first to the last, and of the same length as the transverse; the lumbar 3, with long spinous and transverse processes; one sacral, to which rudimentary pelvic bones are suspended; cau-

lief that the Hebrews covered with its skin their tabernacle and sacred ark; this is generally considered a mere variety. An allied fossil genus, *halitherium* (Kaup), is found in the tertiary calcareous deposits of Europe. (See MANATEE.)

**DUGUAY-TROUIN, René**, a French admiral, born in St. Malo, June 10, 1673, died in Paris, Sept. 27, 1736. He distinguished himself as commander of a privateer in the war against England and Holland, and Louis XIV. presented him with a sword, and in 1697 gave him the command of a vessel in the navy. In the war of the Spanish succession he captured more than 300 merchant ships and 20 ships of war. But the exploit which won him the most renown was the capture of Rio de Janeiro in 1711, which brought an immense sum of money to the French government. He was as generous and modest as he was brave.

**DU GUESCLIN, Bertrand**, constable of France, born near Rennes, Brittany, about 1314, died near Châteauneuf de Randon, Languedoc, July 13, 1380. He belonged to an ancient family, and though dull at his studies excelled in all sports and manly exercises. In the tournament given at Rennes in 1338 in honor of the marriage of Charles de Blois with Jeanne de Penthièvre, he unseated the best knights of Brittany, and bore away the great prize. In the war between the rival claimants of the dukedom of Brittany, the count of Blois and Jean de Montfort, he joined the former, and put himself at the head of a band of adventurers. After the defeat and capture of Charles he was one of the Breton noblemen who went to England to treat for his release. After the battle of Poitiers in 1356, Rennes being besieged by the duke of Lancaster, Du Guesclin forced his way into the place with a few followers, and defended it till the siege was raised in June, 1357. Charles de Blois gave him in recompense the lordship of La Roche d'Airiën. Charles V. sent him with a body of troops against the combined forces of England and Navarre, over which he gained a great victory at Cocherel, on the banks of the Eure, in May, 1364. For this he was made count of Longueville and marshal of Normandy. In the latter part of this year, however, he was defeated and taken prisoner by Sir John Chandos at Auray in Brittany. Peace being concluded with England, Du Guesclin's companies began to plunder the richest provinces of France; and to rid the kingdom of them Charles procured the release of their leader at a ransom of 100,000 crowns. Du Guesclin persuaded them to follow him in a crusade against the Moors of Spain, although his real object was to aid Henry of Trastamare in his struggle with his brother Pedro the Cruel for the throne of Castile. On their way southward they levied 100,000 francs upon the pope at Avignon, besides exacting from him absolution and his blessing. They found little difficulty in establishing Henry upon the throne, but Don

Pedro having secured the alliance of England, they were defeated by the Black Prince, and Du Guesclin was captured (1367). The conqueror, hearing it rumored that he feared to release his captive, offered to ransom him for 100 francs or less if he chose. Du Guesclin declared that he was worth 100,000 gold florins, and that if the kings of France and Castile would not ransom him there was not a woman in the kingdom who would not contribute to the sum. On his release he again joined Henry, whom he firmly placed on the throne, after defeating Don Pedro. He was created constable of France in 1370, and for several years was employed in the west and south against the English, regaining many places long occupied by them. The duke of Brittany, fancying himself threatened by Charles, sought the alliance of England, whereupon Charles invaded the province and declared its annexation to France. In consequence of this Du Guesclin resigned his office, and departed for the court of Castile. He paused before Randon, which was besieged by a French army under Marshal Sancerre, and there sickened and died the day before the capitulation. The commander of the garrison, marching out at the head of his troops, placed the keys of the fortress upon the dead body of the hero, who was finally buried in the chapel of St. Denis, by the side of the kings of France. Biographies of Du Guesclin are numerous. Among the more recent are those of Bouillé, *Histoire de Bertrand du Guesclin* (Paris, 1837; Tours, 1843), Fallet (Rouen, 1856-'63), Bérard (Dinan, 1862), and Jamison (London, 1864).

**DU HALDE, Jean Baptiste**, a French geographer, born in Paris, Feb. 1, 1674, died Aug. 18, 1743. In 1708 he became a Jesuit, and was afterward appointed to edit the letters of missionaries in various parts of the world, and especially in China. The result was two works which contributed largely to geographical knowledge: *Lettres édifiantes et curieuses écrites des missions étrangères*, edited by Du Halde from the 9th to the 26th volume inclusive; and *Description géographique, historique, chronologique, politique et physique de l'empire de la Chine et de la Tartarie chinoise* (4 vols. fol., Paris, 1735). An English translation of the latter was published in London (4 vols. 8vo, 1736, 1744; 2 vols. fol., 1742). The *Lettres édifiantes* have been translated into German, and a selection from the earlier volumes appeared in London in 1743, in 2 vols. 8vo, entitled "Jesuits' Letters."

**DUHAMEL, Jean Marie Constant**, a French mathematician, born in St. Malo in 1797, died in Paris in May, 1872. He was a graduate of the polytechnic school, and a teacher there for nearly 50 years. In 1840 he became a member of the academy of sciences, and in 1851 titular professor of the faculty of sciences. He was one of the best mathematicians of the century. His principal works are *Cours de mécanique de l'école polytechnique* (2 vols.,

1845-'6), and *Des méthodes dans les sciences de raisonnement* (1866 et seq.).

**DUIDA**, a remarkable and nearly isolated mountain in the state of Guayana, Venezuela, about 20 m. N. E. of the junction of the Casiquiare and the Orinoco; lat. 3° 10' N., lon. 66° 12' W. Although it is only about 8,000 ft. in height, it is so nearly perpendicular that its summit has never yet been reached by man. Its S. and W. sides are bare and stony to the top; the others, which are less steep, are covered with dense forests. At the beginning and end of the rainy season small shifting flames are seen to play about the highest peaks, inducing the belief that the mountain is a volcano; but they are probably due to gaseous exhalations. Its rock crystals and quartzes were once taken for diamonds and emeralds, to which error the mission of Esmeralda, a few miles from its base, owes its name. The mountain serves as a landmark to the traveller on the Orinoco for a great distance.

**DUILIUS, Caius Nepos**, consul of Rome in 260 B. C., noted for his naval victory over the Carthaginians, the first success ever obtained by the Romans on the sea. The battle was fought off Mylæ in Sicily, and the triumph of Duilius is attributed to his invention of grappling irons, which enabled his men to fight the enemy hand to hand. On his return to Rome he was honored with a magnificent triumph, and a column was raised to commemorate the event.

**DUISBURG**, a town of Prussia, in the province of the Rhine, 15 m. N. by E. of Düsseldorf, near the confluence of the Ruhr with the Rhine, on the railway from Cologne to Minden; pop. in 1871, 30,520. It is surrounded with dilapidated walls, has a gymnasium, a female high school, a library, a botanic garden, and manufactories of woollens, cotton, velvet, leather, tobacco, and porcelain. In the vicinity are extensive sugar refineries and iron forges.

**DUJARDIN, Félix**, a French naturalist, born in Tours, April 5, 1801, died April 8, 1860. He was the son of a poor watchmaker, and was dependent on his own exertions for his education. From 1827 to 1834 he had charge of the public course of lectures in Tours on geometry and chemistry as applied to the arts. In the latter year he went to Paris to prepare a geological description of Touraine, but was persuaded by Dutrochet to turn his attention to zoölogy. He devoted himself chiefly to investigations among the infusoria, and arrived at conclusions which led him to oppose the theories of Ehrenberg and to make a new classification. In 1839 he was appointed professor of mineralogy at Toulouse, and afterward of botany and zoölogy at Rennes. His principal works are: *Observations sur les rhizopodes* (1835); *Promenades d'un naturaliste* (1837); *Histoire naturelle des zoophytes infusoires* (1841); *Manuel complet de l'observateur au microscope* (1842); and *Histoire naturelle des helminthes* (1844). He left unfinished a work

entitled *Histoire naturelle des zoophytes échinodermes*, which was edited and published by M. Hupé in 1861. He founded in 1839 a scientific journal entitled *Hermès*.

**DUJARDIN, Karel**, a Dutch painter, born in Amsterdam about 1640, died in Venice, Nov. 20, 1678. He was a pupil of Berghem; studied in Italy, where his pictures were very popular; went to Lyons, got into debt, and married his landlady, whom he soon deserted, and returned to Amsterdam. To escape from his wife he again went to Italy. On his death the Venetian senate paid him unusual honors. In spite of dissipation, he left a great number of paintings, principally of pastoral scenes and animals.

**DUKE** (Lat. *dux*, a leader; Fr. *duc*), a title belonging originally to the commanders of armies. In the later periods of the Roman empire it designated the military governor of a district, and until the time of Theodosius the rank of dukes was esteemed inferior to that of counts. Subsequently their dignity greatly increased, several provinces often became subject to a single duke, and the title was not disdained by conquerors such as Alaric and Attila. The northern barbarians who invaded the territories of declining Rome adopted, if they had not before borrowed, the titles of duke and count; but among these martial tribes the dukes, as military chieftains, acquired a decided preëminence over the counts, who both in the Byzantine and western empires had been employed chiefly in civil offices. Under the successors of Charlemagne, the governors of provinces generally assumed the title of duke, and achieved an almost absolute independence. The kings of France finally reunited to the crown the dukedoms which had been severed from it; and the ducal sovereignty being extinguished, the name has remained in France only as a hereditary title of dignity. Prior to the revolution dukes were created by letters patent of the king, and were of three kinds, of which those designated as dukes and peers held the first rank, and had a seat in parliament, and certain honors and prerogatives at court. The dignity of the second class or hereditary dukes was transmissible to their male children, but that of the dukes by brevet ceased with themselves. The ducal and all other titles of nobility, abolished at the commencement of the revolution, were reëstablished in 1806. The rank of duke in the royal family of France was superior to that of prince, inferior sometimes to that of count, and always to that of dauphin. In other great families also the title was higher than that of prince. In Germany, where the idea of sovereignty is inseparable from the ducal dignity, this title (Ger. *Herzog*) comes immediately after that of royalty. Under the emperor Henry IV. dukes began to usurp those sovereign rights which they have since exercised, and six dukedoms were then established. Several of the primitive dukes have exchanged their title for that of grand duke. The princes of the house of

Austria bear the title of archduke. The title of duke, or properly prince (Russ. *Kniazh*), was originally borne by the czars of Russia, and that of grand duke or grand prince still distinguishes the princes of that house. The kings of Poland were grand dukes or grand princes of Lithuania. Italy until recently had several sovereign dukes, as the grand duke of Tuscany, and the dukes of Modena and Parma. The title exists also in the Netherlands, and in Portugal and Spain.—In England the dukedom is the highest dignity in the peerage. It was introduced by Edward III., who in 1337 created his eldest son, Edward the Black Prince, then earl of Chester, duke of Cornwall, and subsequently prince of Wales, when the dukedom merged in the principality, and has ever since been vested in the heir apparent to the crown. The second dukedom was conferred, March 6, 1351, upon Henry Plantagenet, son and heir of the earl of Derby, under the title of duke of Lancaster, which dignity expired at his decease without male issue, but was reconferred in 1362 upon John of Gaunt, who had espoused the duke's second daughter, and eventually sole heiress, the Lady Blanche Plantagenet. In the reign of Elizabeth, in 1572, the whole order became extinct; but it was revived about 50 years afterward by her successor in the person of George Villiers, duke of Buckingham. A duke is styled "his grace" and the "most noble," and is officially addressed by the crown as "our right trusty and right entirely beloved cousin and councillor." The present prince of Wales, besides being duke of Cornwall, is duke of Rothesay; his brother Prince Alfred is duke of Edinburgh; the grandson of King George III. is duke of Cambridge; and besides those of the royal family there are in Great Britain 21 English, 8 Scottish, and 2 Irish dukes.

**DUKES COUNTY**, a county of Massachusetts, consisting of a number of islands in the Atlantic ocean, with an aggregate area of 118 sq. m.; pop. in 1870, 3,787. Martha's Vineyard, the largest island, lies about 5 m. S. of Barnstable co., from which it is separated by Vineyard sound. The others are Chappaquidick island and No Man's Land, and the Elizabeth group. In 1872 there were 4 vessels, of 1,297 tons, engaged in the whale fishery, and 39 vessels entered and cleared in the coastwise and carrying trade. The county constitutes a customs district, of which the port of entry is Edgartown. For the year ending June 30, 1872, there were registered, enrolled, and licensed 20 vessels, with an aggregate tonnage of 2,611. Many of the inhabitants are engaged in foreign commerce. A great part of the surface is occupied by low forests, but there are cultivated tracts yielding good crops of potatoes, hay, and grain. The total value of agricultural products in 1870 was \$56,280; of live stock, \$63,555. Capital, Edgartown.

**DUKINFIELD**, or **Duckinfield**, a town of Cheshire, England, on the bank of the Tame,

opposite Ashton-under-Lyne, Lancashire, of which it is a suburb, 7 m. E. of Manchester; pop. in 1871, 26,329. There are extensive coal mines, one of which is 2,070 ft. deep. The growth of the town from a population of 1,737 in 1801 is due to its cotton manufactures.

**DULAURE, Jacques Antoine**, a French author and statesman, born at Clermont-Ferrand in 1755, died in Paris, Aug. 19, 1835. He studied architecture and engineering, but turned his attention to literature, and on the breaking out of the revolution joined the republican party. In 1792 he was elected member of the convention, in which he voted for the execution of the king, but afterward became connected with the Girondists. During the reign of terror he supported himself in Switzerland as an engraver. He afterward returned to France and was elected to the council of 500, but retired from public life after the revolution of the 18th Brumaire, 1799. Among his works are: *Histoire civile, physique et morale de Paris* (7 vols. 8vo, 1821; latest ed. by Leynadier, 8 vols., 1856), and historical sketches of the revolution (6 vols., 1823-'5). As a historian he has not the reputation of impartiality.

**DULCAMARA**, the name under which the dried young branches of *solanum dulcamara* (bittersweet or woody nightshade) are used in medicine. Its virtues, which are supposed to depend partly at least upon the alkaloid solania, are entirely extracted by water, and it is generally given in decoction. It is slightly narcotic and diuretic, but is not largely used. It is given also in solid extract, fluid extract, and infusion. The dose of the decoction is about four tablespoonfuls; of the fluid extract, half a teaspoonful to a teaspoonful.

**DULCE**. **I.** A lake of Guatemala, on the E. coast, near the gulf of Honduras, with which it communicates through a smaller lake, called the Golfete, and the river Dulce or Angostura. It is also called Lake Izabal. It is about 30 m. long by 12 broad, and has from 30 to 60 ft. of water in the deeper parts, shoaling gradually toward the shores. It is formed apparently by the expansion over a valley of the waters of the river Polochic, which enters it on the west. On its S. bank is the little village of Izabal. The Golfete is 15 m. long by 3 broad, and has a depth of from 12 to 15 ft. The Rio Dulce, through which both lakes reach the sea, is a narrow strait winding through densely wooded and almost perpendicular hills. A bar at its mouth prevents the entrance of vessels drawing over 6 ft. On the left bank is the little village of Livingston, named after the founder of the Louisiana code, which was once adopted in Guatemala. **II.** A gulf of Costa Rica, on the Pacific coast, formed by a peninsula whose point, Cape Matapalo, is in lat. 8° 3' N., lon. 83° 15' W. It covers an area of about 800 sq. m. A river of the same name flows into the gulf near its N. extremity, after a course of 75 m. **III.** A river of the Argentine

Republic, which rises in the mountainous district of the province of Tucuman, about lat. 25° 45' S., lon. 65° 50' W., and after a S. E. course of 400 m. loses itself in Lake Porongos. According to some authorities, it passes through the lake and empties into the Rio Salado. Its banks are low and are often inundated in the wet season. Above Santiago it is called the Hondo, and at its head the Tala.

**DULOIGNO** (Turkish, *Olgun*; anc. *Olcinium*), a town of Albania, European Turkey, on the Adriatic, 18 m. W. S. W. of Scutari, and 6 or 7 m. N. W. of the river Bojana; pop. about 8,000. It is on an isolated hill forming a cape which is united to the mainland by an isthmus. It contains a strong castle, has about 1,000 houses, and is the seat of a Roman Catholic bishop. It surrendered to the Romans at the commencement of the hostilities with Gentius, king of the Illyrians, in 167 B. C., and in consequence received the privilege of freedom and exemption from taxation. The Venetians suffered a great defeat here in 1718, their fleet and army being annihilated by a storm and the attack of the Turks. Its inhabitants were once known, under the name of Dulcignottes, as the most formidable pirates of the Adriatic. They now live mostly by agriculture.

**DULCIMER**, an ancient musical instrument, resembling, if not identical with, the psaltery or *nebel* of the Jews. The modern dulcimer consists of a small box, in shape a triangle or a trapezium, containing a number of wire strings stretched over a bridge at each end, and struck with little iron rods or wooden sticks in the hands of the performer.

**DULONG, Pierre Louis**, a French naturalist, born in Rouen, Feb. 12, 1785, died in Paris, July 19, 1838. He studied medicine, which he practised for some time, and then devoted himself to physical science. After numerous analyses and researches upon chlorine and ammonia, he was led in 1811 to the discovery of the chloride of nitrogen. He was twice injured by the explosions of this new compound, and lost an eye and a finger. In 1816 he discovered hypophosphorous acid, and introduced into the nomenclature the prefix *hypo*, to denote a less degree of oxidation. In 1820 he labored with Berzelius in the laboratory of Berthollet, and investigated the origin of animal heat. He found that in the carnivora the heat due to the transformation of oxygen into carbonic acid is not more than one half of the whole, and in the herbivora even a smaller proportion. In 1825 he was appointed on the commission to provide precautions against the explosion of steam boilers; and for four years he labored almost alone with Arago in determining the elastic force of steam at different temperatures. Dulong was a member of the academy of sciences, and in 1832 succeeded Cuvier as perpetual secretary for the department of physical sciences. His numerous works treat particularly of gases and heat.

**DULSE.** See *ALGÆ*.

**DULUTH**, a city, port of entry, and the capital of St. Louis co., Minnesota, at the S. W. extremity of Lake Superior, about 145 m. N. N. E. of St. Paul, opposite and 7 m. N. of Superior City, Wis., in lat. 46° 48' N., lon. 92° 6' W.; pop. in 1870, 3,131, of whom 1,865 were foreigners; in 1873, over 5,000. It is picturesquely situated on the side of a hill which overlooks the lake and rises gradually toward the N. W., reaching the height of about 600 ft. at the distance of a mile from the shore. The buildings are of wood, but blocks of brick and brown stone are in process of construction. The average temperature for the year ending Sept. 30, 1872, was 38·7°, the coldest month being December (7·7°), and the warmest August (68·1°). The rainfall was 34·44 inches. From the hill, looking S., a fine view of the harbor may be obtained. On the extreme right are St. Louis river and bay, shut in by Rice's point on the Minnesota side and Connor's point in Wisconsin, between which there is a narrow outlet. On the left of these is a body of water dotted with islands, known at the N. end as Duluth bay or the inner harbor, and at the S. as Superior bay. Duluth bay is enclosed by Minnesota point, 7 m. long, which stretches nearly across the head of the lake, and has a lighthouse on its extremity; Superior bay is shut in by Superior or Wisconsin point, between which and Minnesota point there is a channel, called the "entry," 600 ft. wide, obstructed by shifting sand bars, which forms the only natural entrance to the inner harbor. On the left of Minnesota point is the outer harbor, protected by a breakwater about a mile beyond. The obstructions of the "entry" are avoided by a ship canal, 250 ft. wide and 16 ft. deep, through the upper part of the point, protected by piers, on the southern one of which a lighthouse is in course of erection. A dike, 1½ m. long, was constructed in 1872 from Minnesota point to Rice's point, completely shutting in Duluth bay from the "entry," but a passage for vessels has been cut through it. The harbor is open about 200 days in the year. Several docks, besides the extensive works of the railroad companies, have been built, and when the improvements in progress and contemplated by the United States government are completed, the city will have a dockage front of 20 m., affording accommodation for the largest vessels. The Northern Pacific and Lake Superior and Mississippi railroads terminate here, and six regular lines of steamers run to Chicago, Cleveland, Canadian ports, and the ports on the S. shore of Lake Superior. The commerce of Duluth, situated as it is in the vicinity of the mineral districts on both shores of the lake, surrounded by a well timbered country, and offering the most convenient outlet for the products of the wheat region further W., is of growing importance. The number of vessels arriving in 1870 was 158; in 1871, 263, with an aggregate tonnage of 161,567; in 1872, 369 (217 Ameri-

can and 61 foreign steamers and 91 American sailing vessels), with a tonnage of 204,159; 76 were from foreign ports and 293 coastwise. The value of goods entered at the custom house in that year was \$1,205,722, of which \$676,571 paid duties, \$141,018 remained in warehouse, and \$388,133 were bonded to Canada. One large grain elevator is in operation, and another is in process of construction, with a capacity of 1,000,000 bushels. Duluth is the seat of a United States land office. A dry dock, capable of accommodating the largest vessels, is in course of construction on Minnesota point. There are 3 large steam saw mills, 1 shingle mill, 2 planing mills, 1 iron foundry (manufacturing engines, boilers, cars, and stoves), 1 manufactory of sashes, doors, woodwork for cars, &c., 1 wagon factory, and 1 railroad machine shop. The total value of manufactures in 1872 was about \$450,000, including 7,500,000 feet of lumber, 1,000,000 shingles, and 1,500,000 laths. A blast furnace with capacity for the production of 6,500 tons of pig iron annually went into operation in November, 1873. The city contains a national bank, with a capital of \$100,000, a state bank with \$60,000, and a savings bank with \$50,000 capital. It is governed by a mayor and a common council of eight members (two from each ward). The assessed value of property in 1872 was \$1,927,120. The amount expended during the year in the erection of business houses and manufactories, and on public improvements, was about \$1,200,000, including \$70,000 on street improvements, \$80,000 on dike, \$75,000 on canal, \$135,000 on docks, \$75,000 in dredging, and \$55,000 on breakwater. There have been 20 m. of streets graded, and 10 m. of sidewalks built. There are a high school, six preparatory schools, two reading rooms, a library of about 1,000 volumes, two daily and three weekly newspapers, and 12 churches—Baptist, Congregational, Episcopal, German Lutheran, Methodist, Norwegian Lutheran, Presbyterian, Roman Catholic, Swedish Lutheran, and Swedish Methodist.—Duluth derives its name from Jean du Luth, a French officer, who visited the region in 1679. In 1860 there were only 71 white inhabitants, and the number had not much increased in 1869, when the place was selected as the eastern terminus of the Northern Pacific railroad.

**DULWICH**, a suburb of London, in Surrey,  $4\frac{1}{2}$  m. S. E. of St. Paul's cathedral, and near Sydenham; pop. in 1871, 4,041. It is chiefly remarkable for its college, founded and endowed in 1619 by Edward Alleyn, a distinguished actor. The college originally consisted of a master, warden, 4 fellows, 6 poor brethren, 6 poor sisters, 12 scholars, and 80 out members. Its income from endowment in 1626 was £800, but through the rise in the value of the estates this has increased to £14,000. The college was reorganized by act of parliament in 1857, and some gross abuses were corrected. One fourth of the revenue is now devoted to

the support of aged people, and the remainder to the educational department, to which boys are admitted on payment of a moderate fee. It supports 24 foundation scholars; and the master must always bear the name of Allen. It has a valuable picture gallery, mainly contributed by Sir Francis Bourgeois in 1810.

**DUMANOIR, Philippe François Pinel**, a French playwright, born in Guadeloupe in July, 1806, died at Pau in November, 1865. He received his education in Paris, and his first play, produced at the Variétés theatre, *La semaine des amours*, was received with favor. He left nearly 200 plays, most of which have been published. Among his most popular pieces are *Don César de Bazan* and *Les premières armes de Richelieu*. D'Ennery was his collaborator in the former, and Bayard in the latter. From 1836 to 1839 he was manager of the Variétés. His *Écoles des agneaux* obtained a gold medal from the minister of state in 1855.

**DUMAS. I. Alexandre Davy (de la Pailleterie)**, a French general, born at Jérémie, Hayti, March 25, 1762, died at Villers-Cotterets, France, Feb. 26, 1806. He was the son of the marquis de la Pailleterie by a negro girl, was sent to France to be educated, and at the age of 14 enlisted, under his mother's name of Dumas, in a cavalry regiment. He was noted for his vivacious temper, handsome figure, and prodigious strength, but at the end of 16 years he was merely a non-commissioned officer. Serving under Dumouriez, he performed several daring acts, and then rapidly passed through every rank, until in September, 1793, he was general of division. In 1796 and 1797 he served in Italy under Bonaparte, and at the battle of Brixen he alone defended a bridge against the enemy, giving the French time to come to the rescue. Bonaparte presented him to the directory as "the Horatius Cocles of the Tyrol." He served with distinction in Egypt, but upon some disagreement with Berthier departed for France. The ship being obliged to put into Taranto, he was arrested by the Neapolitan government and detained for two years. After his release the first consul declined to give him an appointment on account of his republican principles.

**II. Alexandre Davy**, a French dramatist and novelist, son of the preceding, born at Villers-Cotterets, July 24, 1803, died at Puy, near Dieppe, Dec. 5, 1870. After his father's death his mother sent him to school, where he became a good horseman, billiard player, fencer, and shot. At the age of 15 he was placed as copying clerk with a notary; at 18 he began to write for the stage, though none of the plays produced at this period were accepted; and at 20 the pressure of family difficulties sent him to Paris, where Gen. Foy procured for him a small office in the household of Louis Philippe, then duke of Orleans, with a salary of 1,200 francs. He devoted his leisure to completing his imperfect education, wrote some light poems, and in 1825 with MM. Rousseau and De Leuven produced a play called *La chasse et l'amour*.



His first pieces were mostly anonymous vaudevilles; tragedy engaged his attention for a while, but he soon abandoned it. His genius was awakened by the performances of an English company, which in 1827 presented some of Shakespeare's plays in Paris; in common with several of his contemporaries, he felt that the French stage needed reform, and he resolved to be one of the apostles of the new dramatic creed. He brought out on Feb. 11, 1829, a historical play, *Henri III. et sa cour*, constructed with utter disregard of the ordinary rules. It created a sensation, and though assailed by the critics was applauded by the public. Dumas realized from it 30,000 francs in a few months. *Christine, ou Stockholm, Fontainebleau et Rome*, another historical drama in verse, was also well received; and new pieces from him appeared in rapid succession, which, while eliciting severe criticism, drew crowded houses. *Antony* (produced in 1831), if not the best, is the most characteristic production of its author. *Richard d'Arlington* and *Teresa* followed. *Le mari de la veuve* appeared in April, 1832; and the *Tour de Nesle*, first represented in the following month, ran more than 200 successive nights; the germ of this piece had been furnished by Frédéric Gaillardet, but its details, character, and pathos belonged to Dumas. *Angèle* came out in 1833, *Catherine Howard* in 1834, and *Don Juan de Marana*, a fantastic drama, and *Kean* in 1836; the last was written expressly for Frédéric Lemaître. A Roman tragedy, *Caligula*, and *Mlle. de Belle-Isle* followed. Dumas had meanwhile entered the field as a novelist, beginning in 1835 with *Isabelle de Bavière*, a romantic picture of France in the 15th century. His intention was to give, under the title of *Chroniques de France*, a series of novels treating of the most interesting incidents of French history. These, and his *Impressions de voyage*, narrating his travels through Switzerland and Italy, were eagerly read. *Les trois mousquetaires* and *Le comte de Monte Cristo*, both of which appeared in 1844, gave a new character to his reputation. The success of these and similar books was only equalled by the wonderful rapidity with which they were produced. In 1846 he made a contract to furnish two newspapers with an amount of manuscript equal to 60 volumes a year; and this exclusive of his plays and other occasional productions. Such fecundity raised the question whether he was really the author of the books bearing his name. A lawsuit in which he was involved in 1847 with the directors of the *Presse* and *Constitutionnel* brought to light the fact that he had engaged to furnish those journals with more volumes than a rapid penman could even copy; but though he made liberal use of the talents of assistants, he claimed sufficient share in the plan and execution of every work to make it truly his own. A judicial decision finally supported his claim. His daily work aver-

aged 32 pages of an ordinary octavo volume. Among his novels are *Les mémoires d'un médecin*, or rather *Joseph Balsamo, Le collier de la reine, Ange Pitou*, and *La comtesse de Charny*, a romantic review of the latter part of the 18th century. Novel writing did not withdraw Dumas from the drama; besides adapting for the stage some of his most successful romances, he wrote original pieces, such as *Un mariage sous Louis XV.*, *Les demoiselles de St. Cyr*, *Le comte Hermann, La jeunesse de Louis XIV.*, and *La conscience*. He also published historical books: *Louis XIV. et son siècle*, *Le drame de 93*, *Le régent et Louis XV.*, *Florence et les Médicis*. In 1852 he began the publication of his *Mémoires*, a curious autobiography, which also presents interesting sketches of literary life during the restoration. Though a republican, Dumas was on terms of friendship with the royal family of Orleans, used his influence to elicit from them acts of benevolence, and when they were exiled from France he was bold enough to praise the young princes in several public meetings. He tried now to acquire political importance through the publication of a daily newspaper, *La Liberté*, and afterward a monthly review, *Le Mois*; but failing in this attempt, he published for two or three years the brilliant *Mousquetaire*, which he revived in 1857 under the title of *Monte Cristo*, and in which he continued his romances, translations, *Mémoires*, &c. Previous to 1848 his pen produced him a very large income, and he had undertaken, near St. Germain, the building of a country seat, which became celebrated under the name of *château de Monte Cristo*. The revolution cutting short his means, the château, upon which he had expended 450,000 francs, was sold in 1854 at auction for less than a tenth of its original cost. Dumas married in 1842 Ida Ferrier, an actress of the Porte St. Martin. Three years afterward she went to Florence, and died there in 1859. In 1852 he went for a time to Belgium; in 1858 he travelled in Russia, the Caucasus, Greece, and Turkey, and returned to Paris in the spring of 1859. Among his works published in 1858 were *Le capitaine Richard* (3 vols.), *L'Horoscope* (3 vols.), *Les louves de Machecoul* (10 vols.), and *L'honneur est satisfait*, a prose comedy in one act. In 1859 appeared *De Paris à Astrakan*, a sketch of his recent travels. In 1860 he was attached to the expedition of Garibaldi, and published *Mémoires de Garibaldi* and *Mémoires d'Horace*. In the spring of 1870 he went to Madrid to collect materials for a work on Spanish history. A few weeks gave him all the information he cared for, and he returned to Paris. But the war having begun, his MS. could not be profitably used, and he left Paris for Dieppe, was there taken ill, and died on the day when the Prussians entered the city. His remains were removed from the cemetery at Puy, April 15, 1872, to a grave beside his mother's in his na-

tive village. The science of gastronomy was one of his favorite pursuits, and his *Grand dictionnaire de cuisine* was published in 1873. The English translations of his principal novels have attained an immense circulation in the United States. The most popular are "The Count of Monte Cristo," "The Three Guardsmen," "Twenty Years After," "The Vicomte de Bragelone," "Margaret of Anjou," and "The Memoirs of a Physician" and its continuations. "The Life and Adventures of Alexandre Dumas," by Percy Fitzgerald (London, 1873), contains some characteristic anecdotes. **III. Alexandre**, a French novelist and dramatist, natural son of the preceding, born in Paris, July 28, 1824. At 17 he published a volume of light poems under the title of *Péchés de jeunesse*; then he took to novel writing, and produced *Aventures de quatre femmes et d'un perroquet*, *Le roman d'une femme*, *Le docteur Servans*, *Trois hommes forts*, and *La vie à vingt ans*, which indicated neither extraordinary talent nor originality. But the *Dame aux camélias* (1848) showed him under a new aspect. This was the history, slightly embellished, of a woman of the town, Marie Duplessis, with whom he had been on intimate terms, and who had lately died of consumption. His following novels, *Diane de Lys*, *La dame aux perles*, &c., attracted no particular attention, and he then dramatized the *Dame aux camélias*. It drew crowded houses at Paris and all over France, and was set to music by Verdi in his *Traviata*. In the United States several versions were presented at once on the stage. *Diane de Lys* underwent a similar transformation, but not with the same success; and then Dumas wrote original pieces. *Le demi-monde*, performed in 1855, gave new evidence of acuteness of observation, dramatic power, and cutting wit. The same merits are perceptible in *Le fils naturel* and *La question d'argent*, the former a mere drama of the imagination, the latter a satire on the worship of money. *Le père prodigue* appeared in 1859, *L'ami des femmes* in 1864, *Le supplice d'une femme* (with M. de Girardin) in 1865, *Les idées de Mme. Aubray* in 1867, and a complete edition of his dramatic works in 1868. He has also published additional novels. His drama *La femme de Claude* was produced in 1872, and his *Homme-femme* has been translated by George Vandenhoff ("Man-Woman, or the Temple, the Hearth, and the Street," 1873). His new play *Monsieur Alphonse* (1873) was very successful. He was elected to the French academy Jan. 29, 1874.

**DUMAS, Jean Baptiste**, a French chemist and politician, born in Alais, July 14, 1800. Under the patronage of De Candolle, at Geneva, he early acquired considerable proficiency as a botanist and a chemist. In 1821 he went to Paris, married the daughter of Alexandre Brongniart, and was professor of chemistry in the polytechnic school, in the faculty of science, and in the school of medicine. After the revo-

lution of 1848 he was elected to the legislative assembly, and on Oct. 31, 1849, became minister of agriculture and commerce. After the *coup d'état* of Dec. 2, 1851, he was appointed a senator. In 1868 he was elected perpetual secretary of the academy; and in 1869 the London society of chemistry gave him the Faraday medal. He has published *Traité de chimie appliquée aux arts* (8 vols. 8vo, with 4to atlas, 1828-'45), *Leçons sur la philosophie chimique* (1837), *Essai sur la statique chimique des êtres organisés* (1841), *Enquête sur les engrais* (1867), and other works.

**DUMAS. I. Matthieu**, count, a French soldier and historian, born in Montpellier, Nov. 23, 1753, died in Paris, Oct. 16, 1837. In 1780 he sailed from Brest as aide-de-camp to Rochambeau, commander of the French troops sent to assist the Americans, and participated in nearly all the important actions of the war, including the victory of Yorktown. He was afterward for two years employed in the exploration of the seacoasts and islands of Turkey. At the beginning of the revolution he sided with Lafayette and the constitutional party. When Louis XVI. was arrested at Varennes he commanded the troops who accompanied him to Paris. As a member of the legislative assembly he evinced wisdom, firmness of opinion, and considerable oratorical power. During the reign of terror he was sentenced to death, but escaped to Switzerland. After the 9th Thermidor he returned to France, and was afterward elected to the council of 500. Being proscribed as a monarchist on the 18th Fructidor, he fled to Germany, where he commenced his annals of military events. Returning to his country under the consulate, he was intrusted with several important missions. In 1806 he followed Joseph Bonaparte to Naples, was appointed by him minister of war, and organized the Neapolitan army. On the removal of Joseph to Spain he reentered the French army, and actively participated in the campaigns of 1808 in Spain and 1809 in Germany. He was superintendent of the administrative service of the Russian expedition in 1812, escaped the dangers of the disastrous retreat, was made prisoner in Germany in 1813, was liberated on the peace of 1814, and served the Bourbons during the first restoration. On the return of Napoleon from Elba he refused to join him; but yielding to the entreaties of Joseph Bonaparte, he superintended the organization of the national guards. For this he was placed on the retired list when Louis XVIII. resumed the crown. He now continued his *Précis des événements militaires*, giving a copious and lucid account of military operations from 1799 (19 vols., Paris, 1816-'26). The almost total loss of his sight disabled him from completing his work, but did not prevent him from translating a portion of Napier's "History of the Peninsular War" as a supplement to it. He was elected to the chamber of deputies in 1827,

evinced decision and energy during the revolution of 1830, and was instrumental in the elevation of Louis Philippe to the throne. Besides the work above mentioned, he left some interesting personal memoirs, since published by his son under the title of *Souvenirs*. **II. Chrétien Léon**, count, a French soldier, son of the preceding, born in 1800, died at Passy, Feb. 20, 1873. He served in Spain in 1823, and subsequently in Algeria, was severely wounded at the siege of Constantine, and became the principal aide-de-camp of Louis Philippe. After the revolution of 1848 he joined the Orleans family in England, and attended the count d'Eu, son of the duke de Nemours, on his marriage, Oct. 15, 1864, with the princess Isabella of Brazil. He returned with the Orleans princes to France during the German invasion, and fought gallantly.

**DUMBARTON**, a royal, parliamentary, and municipal burgh and seaport of Scotland, chief town of Dumbartonshire, situated on the left bank of the Leven, near its junction with the Clyde, 13 m. N. W. of Glasgow; pop. in 1871, 11,414. It consists of one long semicircular street, and smaller streets and alleys diverging from it. On the opposite bank of the river is the suburb of West Bridgend, connected with it by a stone bridge. The principal business is ship building, both in wood and iron, there being five large yards employing over 3,000 men. A marine engine factory employs 400 men, and there are also two founderies, a forge, glass and bleaching works, a manufactory of patent windlasses, and a brewery.—Dumbarton is supposed to have been the Roman station Theodosia. At the confluence of the Leven with the Clyde, a mile below the town, is Dumbarton castle, famous in Scottish history, on an isolated precipitous rock upward of 500 ft. high and about a mile in circumference at the base. It is known to have been a stronghold 1,000 years ago, and it has sustained many sieges. Sir William Wallace was imprisoned here before being taken to London for execution.

**DUMBARTONSHIRE**, a W. county of Scotland, anciently called Lennox, consisting of two detached portions, the larger lying between Lochs Lomond and Long and the frith of Clyde, the smaller between the counties of Lanark and Stirling; area, including a portion of Loch Lomond, 320 sq. m.; pop. in 1871, 58,839. The surface is mostly mountainous, and the soil, except in the lowlands, is poor. The best land, however, is highly cultivated, producing potatoes, grain, beans, and turnips. Large tracts are devoted to pasturage, and there are several nurseries for raising timber. The principal minerals are coal, ironstone, limestone, and slate. Capital, Dumbarton.

**DUMDUM**, a town and military station of Bengal, British India, 6 m. E. N. E. of Calcutta. It is the headquarters of the Bengal artillery, and the seat of a training school for young officers and recruits from England. It

contains handsome establishments for the officers, a large church, a free school, a depot of musketry, and a cannon foundry.

**DUMERIL**. **I. André Marie Constant**, a French physician and naturalist, born in Amiens, Jan. 1, 1774, died in Paris, Aug. 2, 1860. From 1800 to 1818 he was professor of anatomy and physiology, and subsequently of pathology, in the medical faculty of Paris. In 1825, on the death of Lacépède, whose adjunct professor he had been for 22 years, he assumed his functions as professor of herpetology and ichthyology at the museum of natural history. During four years he also lectured on natural history in the central school of the Pantheon in place of Cuvier. In his most celebrated production, *L'erpétologie générale* (10 vols. 8vo, with an atlas of plates, 1835-'50), which contains the first attempt at a systematic description of all known reptiles, he had Bibron as collaborator. His other principal works are *Éléments des sciences naturelles* (5th ed., 1848), *Ichthyologie analytique* (1856), and *Entomologie analytique* (2 vols. 4to, 1860). **II. Auguste Henri André**, son of the preceding, born in Paris, Nov. 30, 1812, died there, Nov. 12, 1871. He studied medicine, taught natural history and geology at various colleges in Paris, and in 1857 succeeded his father as professor in the museum of natural history. In 1869 he was elected as a member at large of the academy of sciences. He wrote *Des odeurs, de leur nature et de leur action physiologique* (1843), *Histoire naturelle des poissons* (vol. i., 1865), and many disquisitions relating to reptiles and fishes.

**DUMFRIES**, a royal, parliamentary, and municipal burgh of Scotland, capital of Dumfriesshire, situated on the left bank of the Nith, 6 m. from its mouth and 64 m. S. by W. of Edinburgh; pop. in 1871, 15,435. It is irregularly built, but the streets are wide, well paved, and well lighted. Many of the houses, which are generally of red sandstone, are remarkable for elegance, and there are many handsome villas on the hills overlooking the town. There are 13 churches of different denominations, 4 endowed and 30 unendowed schools, and a number of charitable, literary, and scientific institutions. The chief manufactures are woollen cloths, hats, hosiery, shoes, and baskets. There are also large tanneries and breweries. Weekly cattle markets are held on an open space by the river called the "Sands," where large numbers of live stock are transferred to English dealers. Maxwelltown, a suburb on the opposite side of the river, is connected with the town by two bridges, one ancient, the other a handsome modern structure.—Dumfries dates as a burgh from the reign of David I. In 1306 John Comyn was stabbed here by Robert Bruce in the chapel of the Minorite convent. The town was often plundered and burned in the border wars. Robert Burns resided here for several years preceding his death, and his monument is in the burial ground of St. Michael's church.

**DUMFRIESSHIRE**, a S. county of Scotland, bordering on England and Solway frith; area, 1,098 sq. m.; pop. in 1871, 74,794. A large portion of its surface is mountainous, especially in the N. and N. E. parts, where there are summits nearly 3,000 ft. above the sea. There are many lochs, the principal of which are Castle loch of Lochmaben, and Loch Skene, 1,300 ft. above the sea, whose waters form the cascade called the Gray Mare's Tail. Three rivers, the Nith, the Annan, and the Esk, give their names to the three popular divisions of the county, Nithdale, Annandale, and Eskdale; and besides these there are a few smaller streams. Limestone is found in considerable quantities, and there are mines of coal and lead, and some manufactures; but agriculture, and especially the rearing of cattle, sheep, and pigs, are the principal occupations. The county was included by the Romans in the province of Valentia. Capital, Dumfries.

**DÜMICHEN, Johannes**, a German Egyptologist, born at Wissholz, Silesia, Oct. 15, 1833. He studied at the university of Berlin, went several times to Egypt, and each time made valuable discoveries relating to the ancient history and language of that country. He returned to Egypt in 1871 with the archaeological expedition sent out by the emperor of Germany. One of his remarkable discoveries is a history of the first foundation and successive restorations of the temple of Denderah, which he found in a secret passage, and of which he has given a translation in his *Bauurkunde der Tempelanlage von Dendera* (Leipsic, 1865). He has also published *Historische Inschriften altägyptischer Denkmäler, in den Jahren 1863-75 an Ort und Stelle gesammelt* (1867-70); *Altägyptische Tempelinschriften* (1867); *Die Flotte einer ägyptischen Königin aus dem 17. Jahrhundert vor unserer Zeitrechnung* (1868); *Der Felstempel von Abu-Simbel* (1869); and *Photographische Resultate einer auf Befehl des Kaisers von Deutschland nach Aegypten entsendeten archäologischen Expedition, mit Erläuterungen* (Berlin, 1872).

**DUMMER, Jeremiah**, an American scholar, born in Boston about 1680, died in Plaistow, England, May 19, 1739. He graduated at Harvard college in 1699, where he was noted for the vigor and brilliancy of his genius. He studied theology, and afterward spent several years at the university of Utrecht. Soon after his return to America he was sent to England as agent of Massachusetts, and rendered important services. He was intimate with Bolingbroke, and adopted some of his views. He published theological and philosophical dissertations in Latin while at Utrecht, and a "Defence of the New England Charters" (London, 1728; reprinted, 1765).

**DUMONT, Pierre Etienne Louis**, a Swiss scholar, born in Geneva, July 18, 1759, died in Milan, Sept. 30, 1829. He was ordained a minister of the Protestant church of Geneva in 1781, and distinguished himself as a preacher, at the

same time taking a warm interest on the liberal side in the political controversies of his native city. In consequence of the triumph of the aristocratic faction, he went in 1783 to St. Petersburg, where his father had formerly been court jeweller. Here he became pastor of the French Reformed church, and his eloquence attracted much attention; but after a residence of 18 months he went to London, and became in 1785 teacher of the second son of Lord Shelburne. Here he became acquainted with Romilly and Bentham, with the writings and ideas of the latter of whom he was so much impressed as to conceive the scheme of bringing them out in a French version. At the request of the Genevan exiles in London, Dumont in 1789 made a journey to Paris in company with M. Duroverai, ex-attorney of the republic of Geneva. Their object was to attain through their countryman Necker support for the revolution already commenced at Geneva, and an unrestricted restoration of Genevese liberty. He immediately entered into very close relations with Mirabeau, assisting him in the preparation of his speeches, writing his published letters to his constituents, and becoming joint editor with him of a journal called the *Courrier de Provence*. The pecuniary ill success of this publication, the abatement of Dumont's sanguine hopes of political regeneration, the character of Mirabeau himself, and the attacks levelled at Duroverai and Dumont in journals and pamphlets, as being his tools, determined Dumont to leave Paris in March, 1791; but he revisited it several times in that and the following year, finally accompanying Talleyrand's embassy to England, and remaining there. His *Souvenirs sur Mirabeau*, written some ten years after, but which appeared posthumously, contains a very interesting account of his observations and experiences in Paris. After his return to England he devoted himself to drawing from the manuscripts and printed works of Bentham a lucid and popular view of that philosopher's system of jurisprudence. In 1802 he published in Paris the first instalment of his labors, *Traité de législation civile et pénale* (3 vols. 8vo). The work attracted great attention throughout Europe; and in 1806, while Lord Henry Petty, Dumont's former pupil, was chancellor of the exchequer, the sinecure clerkship which he had long held was superseded by a pension of £500. In 1811 he published at London another instalment, *Théorie des peines et des récompenses* (2 vols.), of which two editions appeared at Paris. In 1815 he published at Geneva *Tactique des assemblées législatives*; in 1823 at Paris, *Preuves judiciaires* (2 vols.); and in 1828, *Organisation judiciaire et codification*. All these treatises reappeared in a single collection edited by Dumont, and published at Brussels in 1828, shortly before his death. These works owed almost entirely to the dress in which Dumont clothed them the attention which

they attracted, and the impression which they made; and to his labors Bentham was indebted for his wide-spread reputation in Europe, into the principal languages of which, including the Russian, the *Traité de législation* were translated. When Geneva recovered her liberties in 1814, Dumont hastened thither. He carried with him a small fortune, married, and spent there most of the remainder of his life. He was chosen a member of the sovereign representative council, and did what he could to liberalize and improve the institutions of his native city. In 1817 he laid before the magistrates a draft of a penal code, borrowed principally from Bentham's manuscripts, and accompanied according to Bentham's system with a running commentary of reasons. This was referred to a commission, of which Dumont was a member, and occasioned long and fruitless discussions. He was more successful in obtaining the establishment of a penitentiary on Bentham's panopticon plan.

**DUMONT D'URVILLE, Jules Sébastien César**, a French navigator, born at Condé-sur-Noireau, May 23, 1790, died May 8, 1842. In 1819-'20 he visited the Grecian archipelago and the shores of the Black sea, collected a number of new plants, of which he published descriptions, and investigated the ruins of several ancient cities. In 1822 he accompanied Duperrey in his voyage round the world, and returned in 1825, bringing a rich collection of insects and plants. He went on a second expedition (1826-'9) as commander, and explored the Australian archipelago and the islands of New Zealand and Papua. He discovered several islands which Cook had not perceived, established the locality of the Loyalty isles, and brought home more than 4,000 sketches of scenery and natural history, 10,000 specimens of animals, and more than 6,000 species of plants. In 1837 he undertook, with the sloops of war *Astrolabe* and *Zélée*, his last voyage, to explore the antarctic regions, and circumnavigate the globe through the southern seas. On his return in 1840 he was made rear admiral, and went to Paris to superintend the publication of the account of this voyage at the expense of the government. The second volume had been published when the author was killed, with his wife and son, in a railway disaster on the line of Paris and Versailles. The work was completed under the supervision of M. Vincendon-Dumoulin, in 24 vols. 8vo, with 6 folio vols. of illustrations (Paris, 1841-'54). The departments of zoology, botany, anthropology, geology, &c., were treated by special writers attached to the expedition.

**DUMOURIEZ, Charles François**, a French general, born in Cambrai, Jan. 25, 1739, died near Henley-upon-Thames, England, March 14, 1823. He served with distinction and was frequently wounded during the seven years' war, and afterward engaged in the war and intrigues which brought on the annexation of Corsica to France, and in the affairs of Poland pre-

vious to the first partition of that country. After the accession of Louis XVI. he was put in command at Cherbourg, where important improvements were accomplished under his direction. In 1787 he was appointed brigadier general. During the first years of the revolution he maintained friendly intercourse with the court, while gaining popularity with the revolutionists. A member of the club of Jacobins, he became in March, 1792, minister of foreign affairs in the cabinet formed by the Girondists. His counsels displeased the king; he also disagreed with his colleagues, who were dismissed, and he himself resigned. Assuming command of the French army on the N. E. frontier in August, 1792, he stopped by a series of brilliant operations the advance of the Prussians, who were repulsed at Valmy, Sept. 20. He now crossed the frontier, routed the Austrians at Jemmapes, Nov. 6, took possession of Brussels, and within one month completed the conquest of Belgium. After a visit to Paris, during which he was denounced as secretly negotiating for the rescue of the king, he planned the conquest of Holland; but having been defeated at Neerwinden, March 18, 1793, he plotted with the enemy the overthrow of the republic. The convention summoned him to appear at their bar, and on his refusal the minister of war, Beurnonville, and four commissioners were sent to arrest him. Dumouriez had them seized by some of his hussars and delivered to the Austrians; but he had mistaken the sentiments of his own troops, and was obliged to fly. This he did in company with the young duke de Chartres, the future king Louis Philippe, the soldiers firing at them while they escaped. He was coldly received by the Austrians, and after wandering about the continent went to England, where, in consideration of some secret services, he received a pension of £1,200. He then published his *Mémoires* and a series of pamphlets on the affairs of France. He is charged with having devised plans of military operations against the French, and given directions in 1814 to the allied armies for the invasion of France. However this may be, he did not succeed in conciliating the favor of the Bourbons, and never returned to France.—See *La vie et les mémoires du général Dumouriez*, by himself (3 vols. 8vo, Hamburg, 1794), translated into German and English.

**DÛNA, or Southern Dwina**, a river of Russia, rises in the small lake of Dvinez, near the source of the Volga, in the government of Tver, flows about 600 m. with a very circuitous course, but with a general W. direction, separating the governments of Vitebsk and Livonia from Wilna and Courland, and discharges into the gulf of Riga near the town of the same name. The principal towns on its banks are Vitebsk, Polotzk, Dünaburg, Jacobstadt, Friedrichstadt, and Riga. Navigation is obstructed by rocks and shoals. In spring it is covered with numerous rafts of timber. The river is

connected by canals with the Volga, the Dnieper, the Beresina, the Niemen, and Lake Ilmen. Its waters abound in fish.

**DÜNABURG**, or **Dvinaburg**, a fortified town of Russia, in the government of Vitebsk, on the Düna, 110 m. S. E. of Riga; pop. in 1868, 27,822. It has a considerable trade and famous annual fairs. The principal exports are flax, hemp, tallow, and timber. It is connected by railway with Riga, St. Petersburg, and Kharkov. The fortress, built in 1825, on a site chosen by Stephen Báthori in 1582, is an important strategical point. Dünaburg was founded by the Livonian knights in the 13th century, and was successively annexed to Poland, Sweden, and Russia, and has remained in the possession of the latter power since 1772.

**DUNBAR**, a seaport town of Haddingtonshire, Scotland, at the mouth of the frith of Forth, 27 m. E. by N. of Edinburgh; pop. in 1871, 3,320. It has manufactories of soap, iron, steam engines, sail cloth, and cordage, and some trade. Vessels of 300 tons can enter the harbor, but the navigation is somewhat dangerous. Dunbar is a place of great antiquity, and its castle, now in ruins, was formerly a famous stronghold. In 1296 the Scots were defeated here with great slaughter by the English army of Edward I. In 1337 Black Agnes, countess of Dunbar, defended the castle for nearly five months against the earl of Salisbury. Another important battle was fought near this town in 1650 between Cromwell with 11,000 men and Gen. Lesley at the head of a Scottish army twice as large, in which the latter was decisively defeated.

**DUNBAR, William**, a Scottish poet, born in Salton about 1460, died about 1525. He received the degree of master of arts from the university of St. Andrews in 1479, became a Franciscan friar, and travelled over England and France. Returning to Scotland, he was received at the court of James IV., whom he delighted with his poetical compositions, and with the charms of his conversation. His poems show a mastery of almost every kind of verse. Some of them were printed in 1508; many remained for two centuries in manuscript, but their fame has steadily increased since their publication at Edinburgh and Perth in 1770 and 1778. "The Thistle and Rose" was a nuptial song to celebrate the marriage of King James IV. with the princess Margaret of England. "The Dance" is an imaginative poem, in which Mahoun (a name of Satan derived from Mohammed) asks his principal ministers to entertain him with a mummery, whereupon the seven deadly sins present themselves and deliver verses, which are severe criticisms upon the vices of the time. The short poem of "The Merle and Nightingale" is a picture of the contest between earthly and spiritual affections, the merle recommending a lusty life in love's service, and the nightingale declaring that all love is lost but upon God alone. All the poems of

Dunbar abound in allegory. A complete edition was published in Edinburgh in 1824 by David Laing, with a life of the poet.

**DUNCAN**, king of Scotland. See **MACBETH**.

**DUNCAN, Adam**, Viscount Duncan of Camperdown, a British admiral, born in Dundee, Scotland, July 1, 1731, died near Edinburgh, Aug. 4, 1804. He early entered the navy, was made a post captain in 1761, and distinguished himself under Keppel in the attack on Havana. In 1780 he was placed in command of a ship under Rodney, and in the engagement off Cape St. Vincent was the first to bring his vessel into action, capturing one of the heaviest of the Spanish ships. In 1787 he became rear admiral, and in 1795 admiral of the blue. In the latter year he took command of the united English and Russian squadron in the North sea, where within two years he annihilated the Dutch commerce. In 1797 he blockaded a large fleet under De Winter in the waters of the Texel, when a serious mutiny broke out in his own squadron. Insubordination had become general in the British navy, and Duncan had but two ships faithful to him. Yet when he advanced against the mutineers, their dissensions caused several of their ships to drop the red flag and return to duty, and the sedition was quickly ended. The Russian fleet was withdrawn. Duncan put into Yarmouth roads for repairs and provisions, where intelligence was brought to him that De Winter had put to sea. He immediately set sail, and with a favorable wind and by a masterly manœuvre placed himself between the Dutch and their retreat. The two fleets met between Camperdown and Egmont, within five miles of the coast, Oct. 11. De Winter was drawing fast toward the land, but Duncan began the action without waiting to form a line. De Winter maintained the contest for some time with his own flag ship after the rest of his fleet had either been captured or had quitted the action, and struck his colors only when his ship was entirely disabled. The loss of the English was 1,030 killed and wounded, while that of the Dutch was considerably greater. The English took nine sail of the line and two frigates. The victory created the utmost enthusiasm in England, where it was hailed as a presage of the downfall of the maritime power of Holland, long the most formidable rival of England on the seas. Duncan was rewarded with a peerage and a pension of £2,000. He remained in active service against the Batavian republic till 1800, after which he retired.

**DUNCAN, Thomas**, a Scottish artist, born at Kinclaven, Perthshire, May 24, 1807, died in Edinburgh, May 25, 1845. He was professor of coloring and drawing in the academy of Edinburgh, and an associate of the royal academy. His picture of "Charles Edward asleep after the battle of Culloden, protected by Flora McDonald," has been frequently engraved. Among the finest of his other pieces are "Charles Edward and the Highlanders enter-

ing Edinburgh, after the Battle of Prestonpans," and the "Martyrdom of John Brown of Priesthill." He excelled in portraits, of which he executed a large number.

**DUNCKER. I. Karl**, a German publisher, born in Berlin, March 25, 1781, died there, July 15, 1869. He was a clerk in a Leipsic and Berlin publishing house, and established in 1809 a house in the latter city, of which he became the sole proprietor in 1828, after the death of his partner Peter Humblot. The writings of Hegel, Ranke, and other celebrated authors were issued from his press. He sold his establishment in 1866 to K. Geibel of Leipsic, who continues it under the old firm name of Duncker and Humblot. **II. Maximilian Wolfgang**, a German historian, son of the preceding, born in Berlin, Oct. 15, 1811. He graduated at Halle, and became professor there in 1842. In 1848 he was a member of the Frankfurt parliament and of the Prussian diet. His published strictures on the Prussian foreign minister, Mantuffel, interfering with his promotion at Halle, he went in 1857 as professor to Tübingen, and on the formation of the Hohenzollern cabinet went in 1858 to Berlin as an assistant in the ministry of state. In 1861 he was appointed councillor of the crown prince, and in 1867 director of the Prussian archives. His principal work is *Geschichte des Alterthums* (4 vols., Berlin, 1852-'7).—His brother, **FRANZ GUSTAV**, born June 4, 1822, a publisher of Berlin, was a leader of the German progressive party in 1848, member of the Prussian diet in 1861, a founder of trades unions in 1869, and in 1871 the chief of a movement for the promotion of culture among the people by a German national union. Another brother, **HEERMANN**, is also prominent as a liberal politician.

**DUNDALK**, a seaport town and parliamentary borough of Ireland, in the county Louth, near the mouth of the Castletown river, 45 m. N. of Dublin; pop. in 1871, 10,893. It has a good harbor on Dundalk bay, and contains a number of schools and literary and benevolent institutions. The manufactures comprise flax spinning, machinery, and agricultural implements, ropes, soap, leather, pins, and starch; and there are also flour mills, breweries, and distilleries. Its trade is important and increasing, especially in agricultural products, which are largely exported. It is connected by railway with Belfast, Drogheda, and Dublin.

**DUNDAS**, an E. county of the province of Ontario, Canada, bordering on the St. Lawrence river, which separates it from New York; area, 377 sq. m.; pop. in 1871, 18,777. It is intersected by the Rivière de la Petite Nation, and crossed by the Grand Trunk railway. Its capital, Morrisburg, is a port of entry, and a stopping point for steamers plying between Montreal, Kingston, and Hamilton.

**DUNDAS, Henry**, Viscount Melville, a British statesman, born in Edinburgh about 1741, died there, May 27, 1811. He was of the ancient family of Dundas of Arniston, received his

education at the high school and university of Edinburgh, and was admitted to the bar in 1763. His celebrity as an advocate gained him the appointment of solicitor general in 1773; he was returned to the house of commons for the county of Edinburgh in 1774, and was made lord advocate of Scotland in 1775. He was afterward member of parliament for the city of Edinburgh till his advancement to the peerage. Though he had been a supporter of the administration of Lord North, his familiarity with affairs made him a valuable accession to the administrations of Rockingham and Shelburne, which quickly succeeded, in the second of which he held the office of treasurer of the navy. This ministry was obliged to give way before the combined opposition of Fox and Lord North, who came together in 1783 to form the coalition ministry, the opposition to which was headed by Pitt and Dundas. The latter had been appointed chairman of a secret committee of the house of commons to inquire into the condition of British India and the causes of the war in the Carnatic, and he made an elaborate report, in which he exhibited a complete mastery of the subject. When Pitt was called to the helm of affairs with a majority in parliament against him, he was powerfully aided by Dundas, who again held the office of treasurer of the navy, and in Pitt's absence led the ministerial party in the house of commons, and whose dexterity as a debater and minute acquaintance with Indian matters were of especial value in carrying Pitt's India bill through parliament against a very serious opposition. Dundas became president of the board of control under this bill in 1791, and entered the cabinet as secretary of state for the home department. He exchanged this post for that of secretary of war in 1794, when he introduced a bill for restoring the estates in Scotland forfeited on account of the rebellion of 1745. The investigations of Dundas into eastern affairs originated those discussions which terminated in the impeachment of Warren Hastings; but he took no active part either for or against Hastings. He was the principal supporter of Pitt during the wars with France, and resigned his offices upon the retirement of that statesman in 1801, when he laid before parliament a favorable statement of the condition of the East India company's affairs. In 1802 he was raised to the peerage with the titles of Viscount Melville and Baron Duneira, and on Mr. Pitt's return to power in 1804 became first lord of the admiralty. He quickly retired from this office, having incurred a charge of violating one of the statutes which he himself had proposed, by which the treasurer was forbidden to receive any perquisites or make any private or individual use of the public money. The articles of impeachment were prepared by the most celebrated leaders of the opposition, and the trial opened April 29, 1806. It resulted in the acquittal of Lord Melville by

triumphant majorities. From this time he took part only occasionally in the debates of the house of lords, and spent the most of his time in Scotland. Edinburgh contains two public monuments to his memory. He published several political pamphlets.—His only son, ROBERT, second Viscount Melville, born March 14, 1771, was first lord of the admiralty in 1812-'27, during which time several arctic voyages were organized, and some discoveries were named after him. He again held the office in 1828-'30, and died June 10, 1851.

**DUNDEE**, a royal and parliamentary burgh and seaport town of Forfarshire, Scotland, on the left bank of the estuary of the Tay, 36 m. N. N. E. of Edinburgh; pop. in 1871, 118,974. It occupies the declivity of a hill, whose summit is 525 ft. above the level of the sea, and is rather irregularly built. The modern streets are spacious and handsome. The principal

increase of £200,000 over those of the preceding year. There are railway connections with Perth and Edinburgh. Dundee is governed by a provost, four bailies, a dean of guild, a treasurer, and 21 councillors.—During the reigns of the Scottish kings Dundee was one of their places of residence. At the period of the reformation it was called "the second Geneva" for its zeal in behalf of Protestantism. In 1645 it was besieged, taken, and plundered by Montrose. In 1651 it was stormed by Gen. Monk, and a sixth part of its inhabitants massacred. A splendid public park, the gift of Sir David Baxter, was presented to the people of Dundee, Sept. 9, 1862, on which occasion a statue of the donor was unveiled.

**DUNDONALD**, Thomas Cochrane, earl of, more commonly known as Lord Cochrane, an English admiral, born Dec. 14, 1775, died Oct. 31, 1860. He was the eldest son of Archibald, ninth earl of Dundonald. At the age of 17 he

entered the naval service, and during the war with France signalized himself in many actions. Some of his exploits in capturing vessels against great odds are among the most brilliant in the history of the British navy. In 1801 he was made a post captain for the capture of a Spanish frigate of far superior force to his own. In 1809 he successfully led a fleet of fire ships among the French fleet at anchor in the Basque roads. In 1807 he was elected to parliament for Westminster, and soon incurred the animosity of the govern-

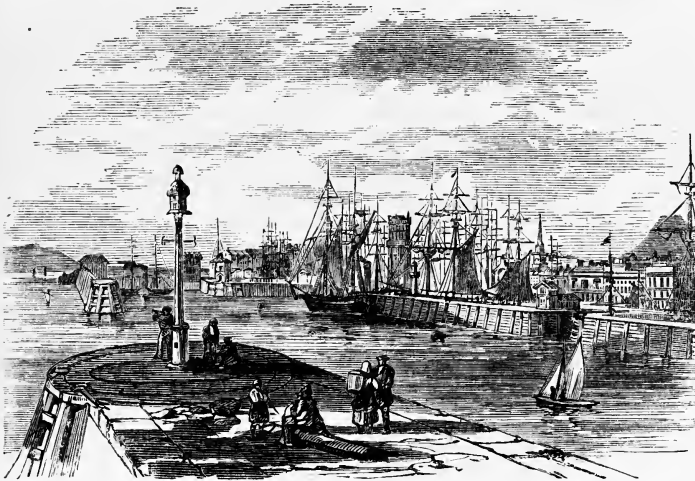

Dundee.

public edifices are the churches, which are very numerous, the old Gothic tower, 156 ft. high, the town hall, custom house, exchange, infirmary, lunatic asylum, industrial school, orphan institution, academy, and savings bank. In the centre of the town is a large market place, from which the principal streets diverge. Some of the docks are large and magnificent. King William's dock has an area of 6½ acres, Earl Grey's of 5½ acres, and the Victoria dock of 14½ acres. There are also several fine quays. The manufactures of coarse linen fabrics, which employ about 25,000 hands, and of jute, exceed those of any other place in Great Britain. It has also extensive manufactures of gloves and leather. Ship building, as well of iron as of wood, is also carried on. The commerce of Dundee is very considerable. In 1871 2,559 vessels of 418,401 tons entered the port. The exports to the United States in 1871 amounted to about £1,200,000, being an

ment by his radical opinions on questions of reform. In February, 1814, a rumor prevailed that Napoleon had abdicated, and Lord Cochrane took advantage of the consequent rise in the funds to sell out. He was charged with originating a false rumor, was convicted of fraud, and sentenced to pay a fine of £1,000, to stand in the pillory, and be imprisoned for a year. The pillory punishment was subsequently remitted. He was at the same time expelled from parliament. His constituents, believing in his innocence, which has since been fully established, immediately returned him to parliament again, and his fine was paid by public subscription. Finding it impossible to obtain employment at home, he attached himself successively to the Chilian, Brazilian, and Greek navies, in each of which he earned fresh laurels, and he was created marquis of Maranham in Brazil. In 1830, on the accession of William IV. and a whig gov-



ernment, he returned to England, and was reinstated and made rear admiral. In 1851 he became vice admiral of the white, and in 1854 admiral of the United Kingdom. He was a man of considerable scientific attainments, and the author of "Observations on Rural Affairs" (1847), "Notes on the Condition of the British West India Islands" (1851), "Narrative of Services in the Liberation of Chili, Peru, and Brazil" (2 vols., 1859), and "Autobiography of a Seaman" (1860).—The succession to his title gave rise to a famous law case. His eldest son claimed the title, which was disputed by a younger brother, who aspersed the character of their mother. The case was decided (June 11, 1863) in favor of the eldest son, THOMAS BARNES COCHRANE (born April 18, 1814), the present earl.

**DUNDRUM BAY**, a bay of the Irish sea, on the coast of the county Down. Its entrance, which lies between St. John's point on the N. E. and the Mourne mountains on the S. W., is about 10 m. wide. It is subject to heavy swells during S. and S. E. winds. Near its N. side are two rocks called the Cow and Calf, connected with the mainland by a reef.

**DUNEDIN**, a city of New Zealand, capital of the province of Otago, on the S. E. coast of the Middle island, and the S. W. side of the harbor of Otago; pop. in 1871, 14,857; including the suburbs of Roslyn and Caversham, 21,511. The city is well paved, has a good supply of water from a reservoir at the head of Water of Leith valley, and is lighted with gas. Among the buildings are the post office, a hospital, and government structures, several banks, the athenæum and mechanics' institute, a masonic hall, and a Presbyterian church, one of the handsomest ecclesiastical buildings in the colony. It is the seat of a Protestant Episcopal and a Roman Catholic bishop, and in 1872 had 12 churches and a synagogue. A regular line of steamers connects Dunedin with Melbourne. The city was founded in 1848, but its more rapid progress dates from 1861, when extensive gold fields were discovered in the neighborhood.

**DUNFERMLINE**, a market town and parliamentary burgh of Fifeshire, Scotland, 13 m. N. W. of Edinburgh; pop. in 1871, 14,958. The houses on its principal streets are generally well built, and many of them have fine gardens. The first factory was established in Dunfermline in 1718, and it has since become one of the most flourishing of the northern manufacturing

towns. Its finest modern edifice is the abbey church, on the site of the ancient church of the abbey, long the place of sepulture of the Scottish kings, and which was destroyed at the

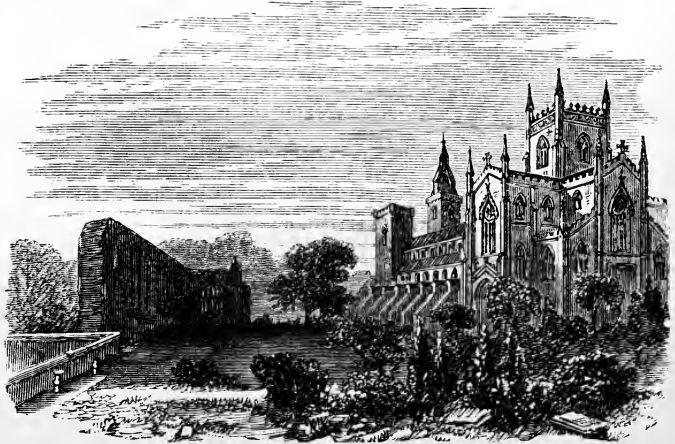

Dunfermline Abbey.

reformation. Beneath its pulpit are the remains of Robert Bruce, which in 1818 were discovered encased in lead.

**DUNGANNON**, a market town and parliamentary borough of Ireland, county Tyrone, 12 m. N. N. W. of Armagh, on the railway from Dundalk to Londonderry; pop. in 1871, 3,955. The town has Episcopal, Methodist, Presbyterian, and Roman Catholic places of worship, and a classical school founded in the reign of Charles II. There are manufactures of linen and earthenware. Dungannon was anciently the seat of the O'Neils, kings of Ulster. In 1782 the Ulster volunteers issued here their resolutions declaratory of the independence of Ireland.

**DUNGARVAN**, a maritime town and parliamentary borough of Ireland, county Waterford, principally situated on a peninsula in the estuary of the river Colligan, 25 m. W. S. W. of Waterford; pop. in 1871, 7,700. The river Colligan divides the town into two portions, connected by a bridge and causeway; the eastern is called Abbeyside. The public buildings are the provincial bank, a fine structure with granite front, two other banks, an Episcopal and two Roman Catholic churches, two convents, a monastery, a fever hospital, and a military barrack. The exports are chiefly grain, butter, and cattle. The inhabitants are largely engaged in hake and herring fisheries.

**DUNGLISON**, Robley, an American physician and author, born at Keswick, England, Jan. 4, 1798, died in Philadelphia, April 1, 1869. He graduated in medicine at Erlangen, Germany, in 1823, and in 1824 was called to the chair of medicine in the university of Virginia, which he held till 1833. He then accepted the professorship of materia medica and therapeutics in the university of Maryland, and in 1836

that of the institutes of medicine in Jefferson college, Philadelphia, which he held until a year before his death. He was a close student of philology and general literature, and enjoyed a high reputation for benevolence, which was especially exercised in giving time and services to the Philadelphia institution for the blind. His principal publications are: "Principles of Human Physiology" (2 vols. 8vo, Philadelphia, 1832; 8th ed., 1856); "New Dictionary of Medical Science and Literature" (2 vols. 8vo, Boston, 1833; 16th ed., revised and enlarged, under the title of "A Dictionary of Medical Science," 1 vol. 8vo, Philadelphia, 1865); "Elements of Hygiene" (Philadelphia, 1835; 2d ed., entitled "Human Health," 1844); "General Therapeutics" (8vo, 1836; 6th ed., 1857); "Medical Student" (8vo, 1837); "New Remedies" (1839; 7th ed., 1856); "Practice of Medicine" (2 vols., 1842; 3d ed., 1848). Dr. Dunglison also translated and edited several foreign medical works. A memoir by his son, Dr. R. J. Dunglison, was published in 1870.

**DUNKELD**, a town of Perthshire, Scotland, on the left bank of the Tay, 14 m. N. W. of Perth; pop. about 1,000. It lies in a picturesque valley, surrounded by mountains. W. of the town, near a bridge crossing the Tay, are the ruins of a cathedral of mixed Gothic and Saxon architecture, whose choir was built in 1330 by Bishop Sinclair. Bishop Lauder finished the nave in 1450, and the chapter house in 1469. The tower was completed in 1501. The building was 120 ft. long and 60 broad. The choir was repaired by the duke of Athol in 1845, and now forms the parish church. The unroofed nave and aisles are used as a cemetery, and contain some interesting monuments. The cathedral was held by a body of lowlanders against the highlanders after the battle of Killiecrankie, in 1689. It is said that the Culdees had a settlement here in 729. About 850 Kenneth II. removed the relics of St. Columba hither, and this was the seat of the primacy of Scotland until supplanted by St. Andrews. The old residence of the dukes of Athol is near by, and was partly rebuilt in 1830. It contains in its grounds two larches said to be the first brought into Britain. Dunkeld contains, besides the parish church, Free and Independent churches, and a royal grammar school founded by James VI.

**DUNKERS**, or **Tunkers**, a religious denomination founded in 1708, at Schwarzenau, Germany, by Alexander Mack and seven others, who, without any knowledge of the existence of other Baptists, were led by reading the Bible to the rejection of paedobaptism. The name Dunker or Tunker (from the German *tunken*, to dip) was originally given them as a nickname to distinguish them from the Menonites. They are also called Tumblers from their mode of baptism, which is by putting the person while kneeling head first under water. They are also called German Baptists, while they

themselves take the name of Brethren. In Germany they established two societies in addition to the original congregation, but these were soon driven by persecution to Crefeld and Holland, while the congregation removed voluntarily to Friesland. Between 1719 and 1729 they all emigrated to America, to which the denomination has since been confined. They are most numerous in Pennsylvania, Maryland, Virginia, Ohio, and Indiana. In 1859 they had 52 churches and about 8,000 members, since which there has been little change. Their church government is nearly the same as that of other Baptists, except that every brother is allowed to exhort. When they find a man apt to teach, they choose him to be their minister, and ordain him by the laying on of hands, attended with fasting and prayer and giving the right hand of fellowship. They also have deacons and deaconesses. From among the teachers who have been tried they choose bishops. An elder among them is, in general, the first or oldest chosen teacher in a congregation which has no bishop. Their annual meeting in May is attended by the bishops, teachers, and other representatives chosen by the congregations. Important cases brought before these meetings are in general decided by a committee of five of the oldest bishops. They use great plainness of dress and language, like the society of Friends; and, like them, they neither take oaths nor fight. They will not go to law, and until lately the taking of interest on money was not allowed among them. They celebrate the Lord's supper, with accompanying usages of love feasts, the washing of feet, the kiss of charity, and the right hand of fellowship. They anoint the sick with oil for recovery, and use trine immersion, with laying on of hands and prayer, even while the person baptized is in the water. They believe in general redemption, though it is with them not an article of faith.—From the Dunkers, as a sect, must be distinguished the Seventh Day Dunkers, also called the German Seventh Day Baptists. They were established by Conrad Beissel, a native of Germany, who had been educated for the ministry at Halle. When a member of the Dunker society at Mühlbach (Mill Creek), Lancaster co., Pa., he published (1725) a tract to prove that the seventh day, and not the first day, was established by Jehovah for ever as the sabbath. This created some disturbance in the society, and he retired to a hermitage on the banks of the Cocalico. He was discovered and joined by many of the society at Mill Creek, who settled around him in isolated cottages, establishing the first community of Seventh Day Dunkers in 1728. In 1733 a monastic society was established, constituting, with the buildings subsequently erected by the community, the irregular enclosed village of Ephrata. The habit of the Capuchins or white friars was adopted by both the brethren and sisters. Monastic names were given to all who entered the cloister. In 1740 there were 36 single brethren in the cloister and 35 sisters,

and at one time the society, including the members living in the neighborhood, numbered nearly 300. The property which belonged to the society by donation, and the labor of the single brethren and sisters, were common stock; but none were obliged to throw in their own property or give up any of their possessions. They considered celibacy a virtue, but never required it, nor did they take any vows in reference to it. When two wished to be joined in wedlock, they were aided by the society. In the earlier days the idea of a universal restoration existed among them; but it has never been taught as an article of faith. About 1740, 40 years before the present general system of Sunday school instruction was introduced by Robert Raikes, Ludwig Hoecker (Brother Obed) established a Sunday school, which was maintained for upward of 30 years. After 1777 the society at Ephrata began to decline, and of the peculiar features of the early Seventh Day Dunkers few traces are now to be found there. A branch of the society was established in 1758 at the Bermudian creek, in York co., Pa., of which likewise but little is left. Another branch established in 1763 at Bedford still flourishes. Their principal settlement is now at Snowhill, on the Antietam creek, in Franklin co., Pa.

**DUNKIRK** (Fr. *Dunkerque*), the most northern town of France, in the department of Le Nord, on the strait of Dover, 150 m. N. of Paris; lat. 51° 2' N., lon. 2° 22' E.; pop. in 1866, 33,083. It is a flourishing place, with an active commerce and manufactories of soap, beet-root sugar, leather, and starch, besides iron works and yards for ship building. Its fisheries are important, especially those of cod and herring, and employ about 100 vessels. The town contains many public buildings, including the town hall built in 1642, the church of St. Eloi, a high bell tower, hospitals, prisons, &c. The port is shallow, but the roadstead is good, and the progress of the commerce of the town since it was made a free port in 1826 has been rapid. The entrances in 1870 were 2,917 vessels, of which 872 were steamers, with a tonnage of 494,576.—The origin of Dunkirk is said to have been a chapel founded by St. Eloi in the 7th century, around which a number of fishing huts were erected. Charles V. defended it with a castle, which has been demolished. It was afterward taken by the English, who lost it again in 1558; and in 1559 it was acquired from the French by the Spaniards, whom the duke d'Enghien (afterward the renowned Condé) drove out in 1646. It soon passed again into the hands of Spain, and was once more taken by the French in 1658, who gave it up to Cromwell in accordance with a previous treaty. Charles II. sold it to France in 1662, and Louis XIV. strengthened its defences. The English made an ineffectual attempt to bombard it in 1695. After the peace of Utrecht its fortifications were dismantled and its port was filled up; the former, having

been restored, were again demolished at the peace of Aix-la-Chapelle, and again repaired in 1783. Ten years later it withstood a siege by the duke of York.

**DUNKIRK**, a village and port of entry of Chautauqua co., New York, 35 m. S. W. of Buffalo; pop. in 1870, 5,231. The Erie and the Lake Shore and Michigan Southern railroads connect it with the principal points both east and west, and the Dunkirk, Alleghany Valley, and Pittsburgh line gives access to the coal and oil regions of Pennsylvania. It is beautifully situated on rising ground on the shore of Lake Erie, and has an excellent harbor, protected by a breakwater. It is a port of refuge during bad weather, and has the advantage of being free from ice earlier than Buffalo. At the western extremity of the bay is a lighthouse, and at the main channel a beacon. For the year ending June 30, 1872, 31 vessels of 3,595 tons entered from, and 30 of 3,548 tons cleared for foreign ports; 61 vessels of 11,946 tons entered, and 64 of 12,258 tons cleared in the coastwise trade. Dunkirk contains extensive iron works, machine shops of the Erie railway, a glue factory, a brandy distillery, 3 breweries, several oil refineries, manufactories of sashes, doors and blinds, flouring mills, &c. There are 2 banks, 4 hotels, 6 public schools, 2 weekly newspapers, and 10 churches.

**DUNKLIN**, a S. E. county of Missouri, bordering on Arkansas, bounded W. by the St. Francis river, intersected by Castor river, and having Lake Pemisicot on its E. border; area, about 700 sq. m.; pop. in 1870, 5,982, of whom 166 were colored. The surface is occupied in great part by prairies and swamps, but the soil is generally fertile where not overflowed. Efforts have been made to reclaim the sunken lands, caused by the earthquakes of 1811 and 1812. The chief productions in 1870 were 256,620 bushels of Indian corn, and 5,267 of wheat. There were 1,211 horses, 1,697 milch cows, 3,251 other cattle, 2,622 sheep, and 11,376 swine. Capital, Kennet.

**DUNLAP, William**, an American painter and author, born in Perth Amboy, N. J., Feb. 19, 1766, died Sept. 28, 1839. In his 17th year he began to paint portraits, and in the summer of 1783 executed one of Washington. The next spring he went to London, and for several years was a pupil of Benjamin West. After his return to America he tried various pursuits, including painting, literary work, theatrical management, &c.; but at the age of 51, after repeated failures, he became permanently a painter. He executed a series of pictures on subjects selected by West and somewhat after his style, which were exhibited in various parts of the United States. He was also one of the founders of the New York academy of design. His "History of the American Theatre," published in 1832, and "Arts of Design in the United States," are standard works of much interest. He also wrote a number of plays, a biography of Charles Brockden Brown, and

a "History of the New Netherlands" (2 vols. 8vo, 1840).

**DUN-LE-ROI**, a town of France, in the department of Cher, on the Auron, 16 m. S. E. of Bourges; pop. in 1866, 5,454. It was formerly a very important town, and in the 12th century was strongly fortified. There are iron mines and quarries of lithographic stone in the neighborhood.

**DUNN**, a N. W. county of Wisconsin, intersected by Chippewa and Cedar rivers; area, 850 sq. m.; pop. in 1870, 9,488. The surface is uneven and generally covered with forests. The soil is fertile. The chief productions in 1870 were 204,346 bushels of wheat, 71,574 of Indian corn, 233,404 of oats, 45,069 of potatoes, 12,329 tons of hay, and 209,830 lbs. of butter. There were 1,567 horses, 2,813 milch cows, 4,512 other cattle, 4,182 sheep, and 4,214 swine; 3 flour mills, 1 planing mill, 14 saw mills, and 2 machine shops. Capital, Menomonee.

**DUNNING, John**, Lord Ashburton, an English lawyer, born in Ashburton, Devonshire, Oct. 18, 1731, died in Exmouth, Aug. 18, 1783. At the age of 19 he went to London, where he was admitted to the bar in 1756. For a long time he obtained little practice; but having been employed in 1762 to draw up the defence of the English merchants against the Dutch East India company, he gained much reputation, which was soon afterward increased by the able manner in which he conducted the case of Wilkes. In 1768 he was elected to parliament, where he sat in the house of commons until he was raised to the peerage in 1782. In 1770 he resigned the office of solicitor general, which he had held for three years. In 1782 he was appointed chancellor of the duchy of Lancaster. He was a strong opponent of the administration during most of the American war; but his reputation is tarnished by his acceptance of a pension of £4,000 after he was raised to the peerage, although he had before objected to the needless and burdensome amount of the pension list, and was very wealthy.

**DUNNOTTAR**, a parish of Kincardineshire, Scotland, on the shore of the North sea, noted for its castle, S. of Stonehaven, now in ruins, which stands on the summit of a perpendicular cliff, 160 ft. high, projecting into the sea, with a deep chasm between it and the mainland; it is approached only by a steep winding path. Sir William Wallace captured it in 1297, at which period it was regarded as one of the strongest places in the kingdom; and the privy council selected it during the wars of the commonwealth as the depository of the regalia of Scotland. It was defended long after every other fortress in Britain had passed into the hands of the protector, but was finally forced to surrender. In 1685 Dunnottar castle became the prison of many of the Covenanters. After the rebellion of 1715 it was dismantled.

**DUNOIS, Jean**, comte de, a French soldier, born Nov. 23, 1402, died Nov. 28, 1468. The

natural son of Louis, duke of Orleans, brother of Charles VI., he early gained warlike distinction under the appellation of the bastard of Orleans. In 1427, in conjunction with Lahire, he raised the siege of Montargis, then beset by the English. In 1428 he threw himself into Orleans, which was hard pressed by a powerful English army, and upheld the spirit of the troops and citizens until they were relieved in April, 1429, by Joan of Arc. Dunois then became a faithful follower of the heroine, sharing in all her exploits, and particularly in her victory at Patay. In 1432 he recovered Chartres by stratagem; and in 1436 he was one of the generals who marched into Paris, to help the citizens in driving out the English. Several measures adopted by the government of Charles VII. were obnoxious to the nobles, and Dunois in 1440 took part in the rebellion headed by the dauphin, and known as *La Praguerie*; but he soon became reconciled with Charles, and in 1449 received the title of lieutenant general of the king, with command of the principal force for the invasion of Normandy. In less than a year, chiefly by his activity, skill, and prudence, all the cities, towns, and fortresses of Normandy were recovered. In 1451 he led his victorious army into Guienne, stormed the town of Blaye on the Gironde, and within three months completed the conquest of that province, Bordeaux included, which for 300 years had been in the hands of the English kings. Nothing was now left them on the continent except the city of Calais and its vicinity. As a reward for his services Dunois was appointed grand chamberlain to the king. After the accession of Louis XI. he was deprived of some of his offices, and joined in 1465 the rebellious league of the great lords, which assumed the name of "league of the public weal;" but on the conclusion of the peace at Conflans, he was restored to his former offices.

**DUNS SCOTUS, John**, a scholastic theologian of the 13th century, born probably in Dunse, Berwickshire, Scotland, about 1270, died in Cologne in 1308. He was educated at Oxford, entered the order of St. Francis, and taught theology and philosophy first at Oxford, and then, his fame having spread all over Europe, at Paris. The acumen and subtlety of his reasoning obtained for him the cognomen of *doctor subtilis*. The controversies between Duns and Thomas Aquinas on the relation of human perception to real objects, and on various religious doctrines, were continued for a long time by their respective disciples, who were called Scotists and Thomists. The reasoning of Duns goes to show that the knowledge derived from human conceptions and experience is real and trustworthy, inasmuch as the fundamental ideas upon which human knowledge rests are identical with the absolute substance (*universale*) of existing objects. Reality is the limitation of the absolute substance by individuation, or, in the quaint terminology of Duns, the *hæc-*

*ceitas*, which might be rendered as the this-and-that-ity. Every existing being consists of substance and privation or limitation, while God is the unlimited absolute substance. The possibilities of limitations or individuations of substance are infinite, and hence follows the existence of accidental chances or occurrences; and hence the free will of individual man and his corresponding responsibility to God. The supernatural knowledge which cannot be derived from real experience is afforded by the Bible, but it is the province of philosophy to show the conformity of the teachings of the Bible with reason. The works of Duns were published by Wadding (12 vols. folio, Lyons, 1639).

**DUNSTABLE**, a town and parish of Bedfordshire, England, 29 m. N. W. of London, on the Great Northern railway; pop. in 1871, 4,558. The parish church is part of a celebrated priory founded in 1131 by Henry I. The town is the principal seat of the British straw plait manufacture.

**DUNSTAN, Saint**, an English prelate and statesman, born near Glastonbury, Somersetshire, in 925, died May 19, 988. Under the patronage of his uncle, the archbishop of Canterbury, he passed some years at the court of Athelstan; but the jealousy of courtiers depriving him of the king's favor, he retired to Winchester, and devoted himself to a monastic life. He built a cell against the wall of Glastonbury church, and there passed his time in prayer, fasting, and manual labor, transcribing manuscripts, painting, and fashioning utensils of metal for the use of the altar. About 942 he became abbot of the then ruined monastery of Glastonbury, and received from King Edmund authority to restore it at the royal charge. In the succeeding reign of Edred his power became almost absolute in the national councils. He restored the strictness of ecclesiastical discipline, and brought the Benedictines into England, but on the accession of Edwy was banished from the kingdom. His share in the story of Edwy and Elgiva has brought him into odium with all believers in that much discussed romance, the facts of which are yet unsettled. Edgar recalled the exiled abbot, doubled his honors, made him bishop of the united sees of Worcester and London, and in 959 advanced him to the primacy as archbishop of Canterbury. The prelate ruled both the monarch and the kingdom. He meted out justice with a stern hand, built up the power of the church, placed Benedictines in the livings of the disorderly secular clergy, and forced the king to do a seven years' penance for a sin of licentiousness. On Edgar's death his influence raised Edward to the throne, to the exclusion of a younger son, Ethelred; but on the accession of the latter in 978 his power was broken, and he retired to Canterbury, and there died. Of the writings attributed to him, only the "Concord of Monastic Rule" is known to be authentic. His life, edited by the Rev. J. E. Green, master of the rolls, was published in London in 1872.

**DUNSTER, Henry**, the first president of Harvard college, inaugurated Aug. 27, 1640, died Feb. 27, 1659. He was president till 1654, when, having become a supporter of the principles of the modern Baptists, he was persuaded to resign his office. He was respected as a modest and pious man, and esteemed an excellent oriental scholar.—See "Life of Dunster," by J. Chaplin (Boston, 1872).

**DUNTON, John**, an English bookseller and author, born in Grafton, Huntingdonshire, May 4, 1659, died in 1733. He was apprenticed to a bookseller in London, engaged in business for himself, came to New England in March, 1686, with a cargo of books, where he remained about eight months, and after his return embarked again in business, with little success. He conducted a weekly publication called "The Athenian Mercury," resolving all the most nice and curious questions proposed by the inquiring, of which 20 volumes appeared. A selection was made from this in four volumes, called "The Athenian Oracle." He wrote voluminously on religion, ethics, and politics. He gives us, in his "Life and Errors of John Dunton" (London, 1705 and 1818), the "lives and characters of more than 1,000 contemporary divines and other persons of literary eminence," and relates many curious facts in relation to the bookselling business, describing the ministers, booksellers, and other citizens of Boston and Salem. His "Letters from New England," edited by W. H. Whitmore, were published by the Prince society in 1867.

**DUODECIMAL**, proceeding by twelves, a term properly applied to an arithmetical scale using 11 digits and a cipher, which has been zealously advocated as an improvement upon ordinary decimal arithmetic. Thus if we use *g* for ten, and *e* for eleven, the number 275 may be written 1gg. But the term duodecimal is also given to the system of compound numbers sometimes used by artificers in calculating surfaces and solidities from measures taken in feet and inches. Duodecimals in the second sense are considered by most mathematicians as worthless, and in the first sense as not having sufficient superiority over decimals to counterbalance the inconvenience of making a change.

**DU PAGE**, a N. E. county of Illinois, drained by the E. and W. branches of Du Page river; area, 340 sq. m.; pop. in 1870, 16,685. It has a level surface, occupied in great part by prairies. The soil is exceedingly fertile. The Chicago and Northwestern and the Chicago, Burlington, and Quincy railroads traverse it, and the Chicago, Rock Island, and Pacific railroad crosses the S. E. corner. The Illinois and Michigan canal passes along the S. E. border. The chief productions in 1870 were 106,789 bushels of wheat, 331,981 of Indian corn, 860,809 of oats, 72,062 of barley, 141,599 of potatoes, 52,430 tons of hay, 58,504 lbs. of cheese, 548,453 of butter, and 153,611 of wool. There were 6,247 horses, 10,888 milch cows,

7,621 other cattle, 26,932 sheep, and 9,253 swine; 15 manufactories of carriages and wagons, 2 of machinery, 8 of saddlery and harness, 2 breweries, and 6 flour mills. Capital, Naperville.

**DUPANLOUP, Félix Antoine Philippe**, a French prelate, born at St. Félix, Savoy, Jan. 3, 1802. He was brought up in the house of his uncle, a country priest, and in his eighth year was placed at school in Paris. He was ordained priest in 1825, and attached for three years as catechist to the parish of the Assumption. In 1827 he was appointed confessor to the young duke of Bordeaux (now the count de Chambord), in 1828 catechist to the Orleans princes, and in 1830 chaplain to the dauphiness, duchess d'Angoulême, daughter of Louis XVI. In 1834 he opened the course of *conférences* or dogmatic lectures in the cathedral. In 1837 he was appointed superior of the diocesan seminary, and also named vicar general of Paris. Under Archbishop Affre he resigned that office, and in 1849 was nominated to the see of Orleans. In this new career he gave full scope to his plans of Christian education. He opened a school in his own residence, in which he acted as professor, and endeavored in all the establishments under his control to raise the standard of instruction to the highest degree of excellence. At that period a great rivalry existed between the university lyceums or colleges and the schools unauthorized by government. Bishop Dupanloup's efforts and success met with no favor from the administration. It was also at that time that the controversy about the classics arose, growing out of the publication of Abbé Gaume's *Ver rougeur*, in which the use of pagan authors in Christian schools was denounced. The *Univers* and its editor, Veuillot, advocated Gaume's views, and a large portion of the French bishops and clergy coincided in them. Bishop Dupanloup was supported by the remaining members of the episcopate. The pope, however, interfered and made peace between the parties. In 1848 Dupanloup was instrumental in having the first French expeditionary corps sent to the Papal States; and during the whole period of Napoleon's power he was the foremost defender of the temporal independence of the holy see. In 1863, in conjunction with eight other bishops, he issued an address to the French electors, which drew on him the censure of the minister of public worship. Bishop Dupanloup published in November, 1869, a pastoral letter, giving his own private opinion concerning the question of papal infallibility; and a public correspondence on the subject between him and Archbishop Manning excited much attention before the assembling of the council. In Rome, like Archbishop Darboy, he maintained a firm but respectful opposition; and, like him, he was among the first to accept the decree of infallibility when it came. During

the occupation of Orleans by the German troops in 1870 the bishop obtained a mitigation of many of the harsh measures of the military commanders. At the end of the war his people sent him as their representative to the national assembly. There he showed himself favorable to a constitutional monarchy under the reunited house of Bourbon, and advocated a perfect system of education for France, as well as the traditional right of his country to protect the holy see. His principal works are: *Exposition des principales vérités de la foi catholique* (2 vols., 1832); *Méthode générale de catéchisme* (2 vols., 1841); *Éléments de rhétorique sacrée* (1841); *L'Éducation* (3 vols., 1855-'7); *Œuvres choisies* (4 vols., 1861); and *Histoire de N. S. Jésus-Christ* (1872).

**DUPATY, Charles Marguerite Jean Baptiste Mercier**, a French jurist, born in La Rochelle, May 9, 1746, died in Paris, Sept. 17, 1788. In 1768 he became advocate general at the parliament of Bordeaux, strongly defended the privileges of the French parliaments against the encroachments of the crown, and was imprisoned. He wrote *Réflexions historiques sur le droit criminel*, and *Lettres sur la procédure criminelle de France* (1788), containing views subsequently embodied in the *Code Napoléon*.

**DUPERREY, Louis Isidor**, a French naval officer, born in Paris, Oct. 21, 1786, died Sept. 10, 1865. He entered the navy in 1802, became an ensign in 1811, and was sent in that year to make a hydrographic survey of the coast of Tuscany, which he accomplished in spite of the English cruisers and the hostility of the inhabitants. From 1817 to 1820 he was with Freycinet on his voyage of discovery, in which he had charge of the hydrographic explorations and charts. On his return to France he was promoted to lieutenant, and in 1822 he commanded an expedition for scientific observation in Oceania and on the coast of South America. During a voyage of 32 months he made investigations in hydrography, magnetism, and meteorology, and on the figure of the earth, and collected many thousands of specimens illustrative of zoölogy and botany. He published a large number of scientific treatises and many maps and charts. His most important researches were in terrestrial magnetism, and he determined accurately the positions of the magnetic poles and the figure of the magnetic equator.

**DUPERRON, Jacques Davy**, a French cardinal, born in St. Lô, Normandy, Nov. 15, 1556, died in Paris, Sept. 5, 1618. He received his education in Switzerland, whither his father, who had given up the practice of medicine to become a Protestant minister, had removed to escape persecution. At the age of 20 he went to Paris, where he abjured Protestantism. Brought to the notice of Henry III., he was appointed reader to the king. Although a layman, he was selected to preach before the king and court; and some of his sermons won him so much praise that he took orders. On

the death of Mary Stuart he was chosen to pronounce her eulogy, in which he spoke so harshly of Queen Elizabeth that the king thought it necessary to disavow his sentiments. Toward the end of the reign of Henry III. he became the confidant of the cardinal de Bourbon, and he has been accused of selling his secrets to Henry IV. He acquired the favor of the latter monarch, who created him in 1591 bishop of Évreux; and he was the chief agent in inducing Henry to abandon the reformed religion. After the taking of Paris he went to Rome and persuaded the pope to remove the interdict which had been placed upon France. In 1600 he was successful in a theological disputation, held before the court at Fontainebleau, over Duplessis-Mornay. In 1604 he was sent to Rome with the title of chargé des affaires of France, and the same year received a cardinal's hat from Clement VIII. He contributed greatly to the election of Leo XI. in 1605, and in the same year to that of Paul V., so that French influence was retained at the papal court. For these services he was made archbishop of Sens and grand almoner to the king. The principal controversial works of Duperron were collected and published in Paris in 1622 (3 vols. folio). He wrote also a number of hymns, ballads, and poetical satires, a poem entitled *L'Ombre de l'amiral de Joyeuse*, and translated into French verse a portion of the *Æneid* and some of the odes of Horace.

**DU PETIT-THOUARS, Abel Aubert**, a French naval officer, born Aug. 3, 1793, died March 17, 1864. He entered the navy in 1804, and was rapidly promoted. From 1837 to 1839 he was engaged in circumnavigating the globe as commander of the ship *Vénus*. He was afterward made rear admiral and put in command of the fleet in the Pacific. He proposed to his government the establishment of a protectorate over the Society islands; and in 1842, when three French Catholic missionaries were expelled from Tahiti at the instigation of the English missionaries there, he visited that island, demanded reparation, and with the aid of some chiefs placed the island under a French protectorate. In the same year he established a French protectorate over the Marquesas islands; and in 1843, when the English missionary and consul Pritchard persuaded the natives of Tahiti to rise against the French, he drove Pritchard from the island and took possession in the name of France of the whole Society group. At the demand of the English government Du Petit-Thouars was then recalled, and on his return declined the ovations offered him by the opponents of the government. In 1846 he was made vice admiral, and in 1849 elected to the legislative assembly from the department of Maine-et-Loire. He wrote *Voyage autour du monde* (10 vols., with 180 illustrations, Paris, 1840-'49).

**DUPIN. I. André Marie Jean Jacques**, a French lawyer and politician, born at Varzy, Feb. 1,

1783, died Nov. 10, 1865. He was early distinguished as a learned lawyer and an able speaker. A member of the chamber of deputies in 1815, he opposed the motion to proclaim the son of Napoleon I. emperor after his father's second abdication. The same year, in conjunction with Berryer, he was appointed counsel for Marshal Ney, and, gaining great popularity by his defence, was chosen to defend many political offenders. Among his most famous speeches were those in behalf of Béranger in 1821, and of the *Journal des Débats* on the eve of the revolution of 1830. Having become a member of the chamber of deputies, it was in great part through his exertions in that body that the duke of Orleans secured the crown, and he became a member of Louis Philippe's first cabinet. From 1832 to 1840 he was president of the chamber of deputies, and from 1849 to 1851 of the legislative assembly. He made some show of opposition to the government of Louis Napoleon, was taken unawares by the *coup d'état* of Dec. 2, but declined all participation or responsibility in the parliamentary resistance, and retained his office of attorney general. This, however, he resigned on the publication of the imperial decrees of 1852 confiscating the Orleans property; in 1857 he was reinstated. His writings, mainly on legal subjects, are numerous. His *bons mots* were renowned. **II. Pierre Charles François**, baron, brother of the preceding, born at Varzy, Oct. 6, 1784, died in Paris in January, 1873. He entered the navy as an engineer, and was actively employed in France and the Ionian islands. In 1812 a series of scientific papers attracted the attention of the academy of sciences. During 1814 and 1815 he evinced liberal opinions, but finally adhered to the Bourbons. In 1816 he visited Great Britain, to examine the general resources of the United Kingdom. The results of his travels, continued for more than four years, appeared in his *Voyages dans la Grande Bretagne* (6 vols., Paris, 1820-'24), and his *Force commerciale de la Grande Bretagne* (1826). He caused gratuitous lectures on the application of science to industry, for the benefit of workmen and artisans, to be established in the *conservatoire des arts et métiers* at Paris, and was appointed professor of geometry in that institution. His services were rewarded with a barony. In 1825 and 1826 he instituted a private inquiry into the intellectual and productive resources of France, the results of which he embodied in his *Situation progressive de la France depuis 1814*. In 1828 he was elected to the chamber of deputies. He adhered to the government of Louis Philippe, and was made a peer in 1837; but he nevertheless continued his regular course of public lectures. After the revolution of 1848 he was elected to the constituent and legislative assemblies, acted with the majority, and on the overthrow of the republic became a supporter of the imperial government. He wrote numerous works besides those mentioned,

relating mainly to statistics and political economy. He left a fortune of 10,000,000 francs.

**DUPLÉIX, Joseph François**, marquis, a French soldier and statesman, born at Landrecies, Jan. 1, 1697, died in Paris, Nov. 10, 1764. In 1720 he was sent as an agent to Pondicherry, and in 1730 was appointed director of Chandernagore, and during an administration of ten years acquired an immense fortune and changed that insignificant town into a flourishing city. In 1742 he became governor general of the French possessions in India, and through his energy and executive ability raised them to a degree of prosperity until then unknown. When Labourdonnais captured Madras in 1746, Dupléix refused to accede to the terms of capitulation, kept possession of the city, and sent Labourdonnais to France under a charge of treason. Letters of nobility were conferred upon him the same year. In 1748 he defended Pondicherry against Admiral Boscawen, who attacked it with a fleet of 30 vessels and a land force, and forced him to raise the siege. Peace having been concluded at Aix-la-Chapelle, Dupléix turned his attention toward territorial acquisition by political intrigue. On the death of the Nizam ul-Mulk, sultan of the Deccan, he supported the claim of Mirzapha Jung to the throne, and gained in return large possessions, covering 200 leagues of coast. Other acquisitions followed, which were confirmed by the Great Mogul, and France seemed about to obtain paramount power in India. The English, alarmed by these French successes, increased their forces under Lawrence and Clive. Dupléix submitted a plan of operations designed to open the way to Delhi, but the French company rejected it. He was recalled to France in 1754, and spent the rest of his life in a vain endeavor to obtain from the government some reimbursement of the fortune which he had spent in attempting to establish French supremacy in India.

**DUPLESSIS-MORNAY.** See MORNAY.

**DUPLIN**, a S. E. county of North Carolina, watered by the north branch of Cape Fear river; area, 670 sq. m.; pop. in 1870, 15,542, of whom 6,766 were colored. It has a level surface; the soil is generally sandy, but there are fertile tracts in the valleys of the streams. The Wilmington and Weldon railroad intersects it. The county contains several pitch-pine forests. The chief productions in 1870 were 291,633 bushels of Indian corn, 135,581 of sweet potatoes, 1,785 bales of cotton, and 155,599 lbs. of rice. There were 1,176 horses, 3,100 milch cows, 5,620 other cattle, 5,698 sheep, and 20,767 swine; 5 flour mills, 2 saw mills, and 7 manufactories of tar and turpentine. Capital, Kenansville.

**DUPONCEAU, Peter Stephen**, an American lawyer and scholar, born in the Isle of Ré, France, June 3, 1760, died in Philadelphia, April 1, 1844. After studying at colleges in St. Jean d'Angély and Bressuire he went to Paris in 1775, and engaged in translating English books.

He was secretary to Baron Steuben, with whom he came to the United States, and on Feb. 18, 1778, was made captain by brevet in the American service. He accompanied Steuben in all his movements until the close of the campaign of 1779, when the army went into winter quarters in Philadelphia. Here Duponceau was threatened with a pulmonary disease, which for some time prevented him from performing active duty. Toward the close of 1780 he went with Steuben to the south, but renewed ill health forced him to return to Philadelphia early the next summer. Robert R. Livingston, secretary of foreign affairs, gave him a place in his office in October, 1781, which he held until June 4, 1783. He was admitted to the bar in Philadelphia in 1785, and acquired an extensive practice in the courts of Pennsylvania and also in those of the United States, including the supreme court. Jefferson tendered him the office of chief justice of Louisiana, which he declined. In addition to the duties of his profession he devoted much attention to philology. As chairman of the committee of history, moral science, and general literature of the American philosophical society, in 1819 he made a report on the "Structure of the Indian Languages," which at once gave him a high position in this department of knowledge. In May, 1835, he received from the French institute, for a "Mémorial on the Indian Languages of North America," the linguistic prize founded by the count de Volney. In 1838 he published "A Dissertation on the Nature and Character of the Chinese System of Writing," in which he held that the written language was lexigraphic, representing sounds and not ideas. He published several essays, letters, and reviews, and expended several thousand dollars, in an unsuccessful effort to introduce into the United States the production and manufacture of silk. His remaining writings comprise an extensive range of subjects; among which are original treatises on points of law; translations from the Latin, German, and French on similar subjects; various treatises on philology; and numerous contributions to American history, including a translation of "A Description of New Sweden," by Thomas Campanius Holm.

**DUPONT, Jacques Charles**, a French politician, known as Dupont de l'Eure, born in Neubourg, Normandy, Feb. 27, 1767, died in Paris, March 3, 1855. First an attorney at the parliament of Normandy, he became a magistrate, and in 1811 president of the high court of Rouen, which post he held till 1818. He commenced his political career in 1798 in the council of 500, was a member of the legislative corps in 1813, and deputy to the chamber from his native department in 1814. He was constantly reelected from 1817 to 1848, and won the esteem of both friends and opponents. On the revolution of 1830 he accepted the ministry of justice, but left the office after a few months to resume his seat among the lib-



eral opposition in the chamber of deputies. In February, 1848, he was elected president of the provisional government, but old age interfered with his activity. He was elected to the constituent assembly, and in 1849 retired to private life.

**DU PONT, Samuel Francis**, an American naval officer, grandson of Du Pont de Nemours, born at Bergen Point, N. J., Sept. 27, 1803, died in Philadelphia, June 23, 1865. He entered the navy as midshipman Dec. 19, 1815, was promoted lieutenant in 1826, and commander in 1843. Ordered in 1845 to the Pacific in command of the frigate Congress, Commodore Stockton's flag ship, he reached Monterey (1846) just as the Mexican war began. Transferred at once to the command of the sloop of war Cyane, he did much active and gallant service on the California coast. At the capture of Mazatlan under Commodore Shubrick, in November, 1847, he headed the line of boats which entered the main harbor, and in February, 1848, landed at San José with a force of sailors and marines, marched three miles under fire, and defeated a large body of Mexicans, relieving Lieut. Heywood's little garrison, closely besieged and about to surrender. He became captain in 1856, and was sent on special duty to China in 1857, in command of the steam frigate Minnesota, returning in 1859, after a cruise to Japan, India, and Arabia. Placed in command of the Philadelphia navy yard Jan. 1, 1861, he rendered important services at the breaking out of the civil war. He was appointed flag officer in the following September, and assigned to the command of the South Atlantic blockading squadron. On Nov. 7 he attacked and captured, after a severe battle of four hours, the forts at Hilton Head and Bay Point, defending Port Royal harbor, S. C. His squadron, led by the flag ship Wabash, steamed thrice in an elliptic course between the forts, firing at each in turn; this skilful disposition saved his wooden ships from material injury. In August, 1862, he became rear admiral upon the creation of this rank in the United States navy. On April 7, 1863, Admiral Du Pont made a very gallant though necessarily unsuccessful attack with ironclads upon Fort Sumter. He was relieved from his command in the following July. He died of disease originated by his cruise in the East Indies. During the intervals of more than 25 years of sea service, Admiral Du Pont was constantly employed on important professional duties. He was the author of a treatise on the use of floating batteries for coast defence, which has been republished and highly commended in England.

**DUPONT DE L'ÉTANG, Pierre**, count, a French general, born at Chabannais, Angoumois, July 14, 1765, died Feb. 16, 1838. Appointed brigadier general in 1793 and general of division in 1797, he joined Bonaparte on the 18th Brumaire, contributed to the victory of Marengo, and at the close of 1800 defeated an over-

whelming Austrian force at Pozzolo on the banks of the Mincio. He won new laurels in 1805 and 1806 during the campaigns in Austria and Prussia, and in 1807, by a bold movement against the Russian imperial guard, decided the victory of Friedland. Sent to Spain in command of the army which was to conquer Andalusia, he was successful at first, but was surrounded in the Sierra Morena by a Spanish army under Castaños, and surrendered with his whole force, July 22, 1808. For this act, known as the capitulation of Baylen, Dupont was by imperial decree degraded from his rank and sent to the fort of Joux in the Jura. The fall of the empire restored him to liberty, and his supposed hatred of the emperor led to his appointment as minister of war, and the cancelling of all the proceedings against him; but he was soon dismissed from that office. After the second restoration he was appointed member of the privy council. His native department elected him several times to the chamber of deputies. He published pamphlets on the recruiting system and the campaign of Austria, and observations on Montgaillard's *Histoire de France*.

**DU PONT DE NEMOURS, Pierre Samuel**, a French economist and statesman, born in Paris, Dec. 14, 1739, died near Wilmington, Delaware, Aug. 6, 1817. Two pamphlets on the finances, published at the age of 23, gained him the acquaintance and regard of the celebrated Quesnay. Of all the economists, Du Pont did most to give currency to the doctrines of the school. His work, *De l'exportation et de l'importation des grains* (1764), caused Turgot to seek his acquaintance, and they became intimate friends. During the next eight years Du Pont published among other books *Physiocratie*, an analysis of Quesnay's system (1768), and *Le commerce de la compagnie des Indes* (1769); he also edited the *Journal de l'agriculture, du commerce et des finances*, and from 1768 the *Éphémérides du citoyen*, the organ of the school. Upon the suppression of the latter in 1772, Du Pont, who had received various titles and decorations from foreign princes, was invited to Poland by King Stanislas Augustus, and made secretary of the council of public education, and governor of his nephew, Prince Adam Czartoryski. When Turgot became comptroller general (1774), Du Pont was recalled to France, and took part in all the reform measures of that minister, particularly in financial matters, most of the principles upon which the French treasury is now conducted being derived from the measures which Du Pont attempted to carry out at that time. He also prepared the scheme for provincial administration recommended to the king by Turgot. Upon Turgot's disgrace (1776), Du Pont was banished from Paris, and busied himself with agricultural and literary pursuits, reappearing in print with a translation of a part of Ariosto's *Orlando furioso* (1781), and after Turgot's death with a memoir of his friend (1782). Re-

called to public life by Vergennes, he negotiated with the English envoy, Dr. James Hutton, the treaty of 1782, which recognized the independence of the United States, and later the commercial treaty of 1786 with Great Britain. For these services he was made councillor of state and inspector general of agriculture and commerce. In 1787 he was secretary of the assembly of notables, and instigated and drew up the famous memorial upon abuses which Calonne laid before it. On the fall of this minister the personal interference of Louis XVI. saved him from another banishment. Member of the states general from Nemours in 1789, and later of the constituent assembly, of which he was twice president, he was a steadfast advocate of constitutional monarchy and opposed the extreme revolutionists. For his opposition to the issue of assignats he was mobbed on leaving the assembly, and his life was with difficulty saved by the national guard. Upon the dissolution of the constituent assembly he exerted himself to resist the excesses of the revolution, but was marked for destruction after the 10th of August, 1792, when he went armed to the palace with his son to defend the king. He succeeded in escaping to the country after being hidden in the observatory for several weeks by the astronomer Lalande, and while in concealment wrote his *Philosophie de l'univers*. Finally arrested and imprisoned in La Force, the death of Robespierre saved him from the guillotine. As soon as he was liberated he renewed his struggle against the Jacobins, and helped to organize the unsuccessful revolt of the sections. He was elected member of the council of ancients from Loiret, and became president of the council on the success of the reactionary party in the elections of 1797. When the republicans broke up the councils with Augereau's troops, Du Pont's house and property were destroyed by the mob, and he narrowly escaped transportation to Cayenne. In 1799 he emigrated with his family to America, where he was received with much consideration. Returning to France in 1802, he declined the various appointments which Napoleon offered him, but as a friend of both countries was instrumental in bringing about the treaty of 1803 by which Louisiana was sold to the United States. During the empire he published a work on the bank of France (1806), and *Mémoires sur différents sujets d'histoire naturelle* (1807), and wrote many papers for the institute of France and other learned societies of which he was a member. His plan of national education for the United States, prepared at the request of Jefferson, and published in 1812, though not carried out in the country for which it was intended, has been partly adopted in France. Upon the fall of Napoleon (1814), Du Pont was secretary of the provisional government, and at the restoration became councillor of state. On Napoleon's return from Elba he rejoined his sons in America, where he died

two years afterward. In addition to numerous pamphlets on financial and political subjects, Du Pont also published *De l'origine et des progrès d'une science nouvelle* (1767); *De l'administration des chemins* (1767); *Objections et réponses sur le commerce des grains et des farines* (1769); *Observations sur les effets de la liberté du commerce des grains* (1770); *Table synoptique des principes de l'économie politique* (1775); *Idées sur les secours à donner aux pauvres malades dans une grande ville* (1786); *Notice sur la vie de M. Poivre* (1786); *Analyse historique de la législation des grains depuis 1692* (1789).

**DUPORT, James**, an English scholar, born in Cambridge in 1606, died July 17, 1679. He received his early education at Westminster school. In 1622 he entered Trinity college, Cambridge, and devoted himself especially to the study of Greek. He graduated in 1627, and was immediately elected fellow. In 1630 he was ordained to the ministry, in 1639 became regius professor of Greek in the university, and in 1641 was made prebendary of Lincoln and arch-deacon of Stow. During the commonwealth he was one of the few who were not expelled from the university; but in 1654 he was displaced from his professorship, although he continued his labors as fellow and tutor. On the restoration Duport was appointed king's chaplain. He was made D. D. in 1660, dean of Peterborough in 1664, master of Magdalen college in 1668, and vice chancellor of the university in 1669. Among his numerous publications are a Greek poetical version of the book of Job (1637), also of Proverbs, Ecclesiastes, and Song of Solomon, with Latin translations (1646); *Gnomologia Homeri* (1660); translation into Greek of the "Book of Common Prayer" (1665); the Psalms of David in Greek hexameters (1666); and "Lectures on Theophrastus's Characters" (1712).

**DUPRAT, Antoine**, a French cardinal and statesman, born at Issoire, Jan. 17, 1463, died July 8, 1535. He was successively bailiff of Montferrand, government advocate at Toulouse, member of the council of state, and president of the parliament of Paris. On the accession of Francis I., in 1515, he became chancellor and prime minister. In a conference with the pope at Bologna he conceded the abolition of the pragmatic sanction, and secured for the king the power of appointing the French bishops. His wife dying in 1516, he took orders, and was made archbishop of Sens, and finally a cardinal. The great object of his administration was to centralize all power in the hands of the king. To this end he sought to lessen the consequence of the constable duke de Bourbon by setting up the adverse claim of the queen mother Louise of Savoy to his great inheritance, thus driving him into an alliance with Charles V., and securing at his death in 1527 the confiscation of all his possessions in favor of Francis I. For the same purpose Duprat attacked the powers and privileges

of the parliament, and succeeded in reducing it to a mere judicial body, and freeing the king from all control. Duprat was noted for his subservience to the king, his cupidity, and his intolerance.

**DUPREZ, I. Gilbert Louis**, a French tenor singer, born in Paris, Dec. 6, 1806. He received his musical education at the conservatory, and was admitted to the singing school of Choron. In 1825 he was engaged at the Odéon, and married two years later Mlle. Dupéron, a vocalist. After a successful tour through the principal cities of Europe, he obtained in 1837 an engagement at the Opéra in Paris, and continued there till 1849, when he retired from the stage. He was a professor at the conservatory from 1842 to 1850. He produced some of his own compositions on the stage, but they failed. The principal ones are *Joanità* (1852), *La lettre au bon Dieu*, *Jeanne d'Arc* (1865), and an oratorio entitled *Le jugement dernier* (1863). He has also written a work entitled *L'art du chant*. **II. Caroline Van den Heuvel**, a French soprano, daughter of the preceding, born in Florence in 1832. She was one of the principal singers at the Opéra Comique from 1852 to 1856, when she married M. Van den Heuvel. She sang subsequently at the Théâtre Lyrique, and became in 1860 a member of the Opéra. She reappeared recently at the Opéra Comique, but remained only for a short time, and retired from the stage. **III. Édouard**, brother of Gilbert, was for some time a member of the troupe of the Opéra Comique, and has written several librettos for his brother and the composer Verdi. *Le bal masqué*, *Rigoletto*, and *La traviata* are among the best known of his writings.

**DUPUIS, Charles François**, a French scholar and philosopher, born at Trie-le-Château, Normandy, in October, 1742, died near Dijon, Sept. 29, 1809. He was the son of a country schoolmaster, and through La Rochefoucauld was enabled to complete a course of collegiate studies at Paris. In 1766 he was made professor of rhetoric at the Lisieux college, and in 1787 of Latin eloquence in the collège de France. He had a thorough knowledge of astronomy and ancient mythology, and spent the best part of his life in elaborating a theory tracing to the former the origin of all religions. His theory, first presented in several papers in the *Journal des Savants*, was more fully expounded in a 4to volume printed in 1781, under the title of *Mémoires sur l'origine des constellations et sur l'explication de la fable par l'astronomie*, and 14 years later was developed in *L'origine de tous les cultes, ou la religion universelle* (3 vols. 4to, Paris, 1795). In 1796 he published an abridgment, which has been frequently reprinted. While a deputy to the convention, Dupuis acted with the moderate party; he was a member of the council of 500, and a candidate for the directorship. On the establishment of the empire he returned to private life, and in 1806 published his *Dissertation sur*

*le zodiaque de Tentyra ou Denderah*, the complement of his great work.

**DUPUYTREN, Guillaume**, a French surgeon, born at Pierre-Buffière, Limousin, Oct. 6, 1777, died in Paris, Feb. 8, 1835. At the age of 12 he was placed in the college of La Marche at Paris, where he engaged in literary studies, but was rebellious, abandoned Latin for the sciences, and became enthusiastic only after undertaking the study of medicine. At 18 he was appointed one of the six assistant dissectors in the newly established schools of health; and in 1801 he succeeded Duméril without competition as curator of the anatomical department. He displayed unprecedented skill and activity in dissection, and became successively surgeon of the second class in the Hôtel-Dieu, inspector general of the university, professor of medical practice, and in 1815 surgeon-in-chief of the Hôtel-Dieu. Having now absolute power in the oldest and wealthiest hospital of France, he regularly passed five hours in the morning in performing operations in the presence of more than 400 students. After the fatal attack on the duke de Berry, in 1820, Dupuytren was called to the Tuileries for consultation, and three years later he was made first surgeon to the king. His proud, silent, and capricious character was the object of innumerable epigrams and calumnies. His health failed in 1833, and he went to Italy, but soon returned and resumed his lectures. He died after much suffering, which excited rather his curiosity than complaints or disquietude, and left a part of his fortune for the foundation of a chair of pathological anatomy in the faculty of medicine in Paris, and of a museum which bears his name. His principal works have been collected in an edition entitled *Leçons orales*. He simplified many surgical operations, and made some valuable innovations.

**DUQUESNE, Abraham**, a French naval officer, born in Dieppe in 1610, died Feb. 2, 1688. He was educated in his native town, early entered the naval service, and gained distinction in several encounters with the Spaniards, especially in 1637 off the isles of Lérins, in 1641 off Tarragona, and in 1643 off Cape de Gatte. Hostilities being suspended, he entered the Swedish service in the latter year as vice admiral, and in 1644 completely defeated the Danish fleet commanded by King Christian IV. in person. He soon afterward returned to France, and in 1650 fitted out a squadron at his own expense, with which he prevented the Spaniards from entering Bordeaux, then the stronghold of the rebellious princes. After the peace of 1659 he served against the pirates on the coast of Africa. He was made naval lieutenant general in 1667, and in the war with Holland was twice engaged against De Ruyter in 1676, in the Mediterranean. In both engagements the Dutch were defeated, and in the latter they lost their commander. A few weeks later Duquesne destroyed the remains of their fleet, and secured the naval supremacy of France.

Louis XIV. bestowed upon him the estate of Du Bouchet with the title of marquis. He was ordered to clear the Mediterranean of the Barbary pirates; defeated the Tripolitans off the island of Scio in 1681; attempted in 1682 the bombardment of Algiers, which stormy weather obliged him to abandon; resumed it the next year, and forced the dey to sue for peace. The first condition imposed by Duquesne was the liberation of a considerable number of Christian slaves. In 1684 he led a successful expedition against Genoa, and soon after retired to his native city. Duquesne was a firm Protestant, and after the revocation of the edict of Nantes he alone of all the French Protestants was permitted to remain in France and retain his rank and honors. His four sons, two of whom, Henri and Abraham, had served under him with great distinction, were compelled to leave their country; but their father obtained from them a promise, which they rigidly kept, never to serve against France.—See *Duquesne et la marine de son temps*, by Henri Plon (Paris, 1872).

**DUQUESNE, Fort.** See PITTSBURGH.

**DURAM**, or *Durão*, **Jozé de Santa Rita**, a Brazilian poet, born near Mariana, province of Minas Geraes, in 1737, died in Lisbon in 1783. He became an Augustinian monk after graduating as doctor of divinity at the university of Coimbra, and was professor of theology there from 1771 till his death. His chief work is a poem founded on the story of the Galician adventurer Diogo Alvarez Correa, surnamed Caramurú, the legendary hero of Bahia, which was published at Lisbon in 1781, under the title of *Caramurú, poema epico do descobrimento da Bahia*, and a French version appeared at Paris in 1829. The poem has gradually risen to the rank of a national epic in Brazil. Duram wrote other poems and prose works.

**DURAND, Asher Brown**, an American painter and engraver, born at Jefferson, Morris co., N. J., Aug. 21, 1796. His art education commenced in the shop of his father, a skilful watchmaker, where he acquired some knowledge of the elementary processes of engraving. His first attempts at the production of prints were made with plates hammered out of copper coins, and with tools of his own construction, his models being the cards inserted in the cases of watches. In 1812 he was apprenticed to Peter Maverick, an engraver of New York, with whom after the expiration of his term in 1817 he entered into partnership. His engraving of Trumbull's "Declaration of Independence," which cost him three years' labor, brought him into general notice, and thenceforth for many years his graver was in constant demand. His "Musidora" and "Ariadne," the latter engraved from Vanderlyn's picture, are among the most creditable specimens of the art produced in this country. In 1835, having for the previous ten years been a regular contributor of portraits, small figure pieces, or landscapes in oil, to the exhibi-

tions of the national academy of design, he finally abandoned engraving as a profession. For several years he painted portraits, landscapes, and occasionally figure pieces, but subsequently gave his exclusive attention to landscape painting. His pictures are pleasing in color and tone, and those representing woodland scenes are conceived with poetic feeling, and present fine studies of trees and foliage. His collected works, many of which are of large dimensions, and some of which have been engraved, would convey an unusually correct idea of American scenery under many different aspects. In 1854 he painted a portrait of William C. Bryant, the engraving from which, published in 1858, received its finishing touches from his hand. Mr. Durand was for many years president of the national academy of design, succeeding Prof. Morse.—His son, JOHN DURAND, conducted for several years a monthly publication called "The Crayon," devoted especially to the interests of the fine arts. He is also the translator of a number of Taine's works, including "Ideal in Art" (1868); "Italy: Rome and Naples" (1868); "Italy: Florence and Venice" (1869); "Philosophy of Art: Art in the Netherlands" (1870); and "Art in Greece" (1871).

**DURANGO. I.** A N. state of Mexico, bounded N. by Chihuahua, E. by Coahuila, S. E. by Zacatecas, S. by Jalisco, and W. by Sinaloa; area, 42,643 sq. m.; pop. in 1868, 185,077. The surface in the W. portion is broken by the Sierra Madre; in the E. are many large plains, with very fertile soil; the N. W. portion is a dreary waste, inhabited by savages. The principal rivers are the Rio de las Palmas, the Nazas, the Mezquital, and the Zunal, all rising in the Sierra Madre. The climate is cold on the mountains, hot on the W. slopes, and temperate in the remainder of the state. Agriculture is neglected, because of the frequent incursions of Indians from the north, by which the herds that once constituted the riches of the inhabitants have been almost entirely destroyed. On western slopes and in sheltered valleys the sugar cane and other tropical plants and fruits are produced; flax and potatoes grow wild in the Sierra Madre; and large quantities of cotton are raised in the valleys. Wheat and other cereals and vegetables of the temperate zone yield large crops in the central districts. Gold is abundant near Santa Maria del Oro, where large quantities of it were once extracted; near the capital are an iron mountain and inexhaustible mines; copper and lead are plentiful; and argenteriferous beds are numerous in the Sierra Madre. There are some schools and colleges; and the government is making efforts for the general diffusion of education. Under the Spaniards the state was called New Biscay. **II.** A city, capital of the state, near the foot of the S. E. slope of the Sierra Madre, in lat. 24° 4' N., lon. 104° 20' W., 480 m. N. N. W. of Mexico; pop. in 1868, 12,449. The city, which is nearly 7,000

ft. above the sea, was founded about 1560 by Alonso Pacheco as a military station, and soon after was made an episcopal see. Its original name was Guadiana, and it is now sometimes called Victoria. The streets are regular, but the houses are generally poor. The only buildings worthy of note are the government house, the cathedral, ten parish churches, and a spacious hospital. There are three small prisons, a penitentiary, a state prison, a coliseum, an arena for bull fights, and a cock pit whose main building presents a sumptuous appearance. There are public gardens, three public squares, and nine public baths. Thermal springs supply water, which runs in open streams through the streets. The inhabitants are remarkable for cleanliness. The climate is temperate, and the thermometer seldom rises above 78° F. There are manufactures of cotton and woollen goods, leather, iron, glass, and tobacco. The mint from 1811 to 1845 coined \$27,962,668. There is an institute in which jurisprudence, languages, and the sciences are taught, a seminary, and several minor schools.

**DURANTE, Francesco**, an Italian composer, born at Frattamaggiore, near Naples, about 1690, died Aug. 13, 1755. His parents were poor, and he was educated at a charity school. He was instructed in music by Scarlatti, and devoted himself to teaching and composition. In 1742, on the departure of Porpora to Germany, Durante was made master of the conservatory of Loretto. His works are 62 in number, mainly ecclesiastical. He was not fertile in melodic ideas, but his harmonies were fine in invention and pure in style. Robert Franz has given to some of this composer's works full modern orchestral accompaniment, and they have been recently revived both in Europe and in this country.

**DURAZZO** (anc. *Epidamnus* or *Dyrrhachium*; Turkish, *Dratch*; Slav. *Durtz*), a town of Albania, Turkey, on the E. coast of the Adriatic, 50 m. S. by W. of Scutari; pop. about 10,000. It is strongly fortified, has a safe and commodious harbor, and carries on a considerable trade in corn, tobacco, oil, wood, and British manufactured goods, which are imported from Trieste. It is the seat of a Roman Catholic archbishop. (See *DYRRHACHIUM*.)

**DURBIN, John Price**, D. D., an American clergyman, born in Bourbon co., Ky., in 1800. At the age of 14 he was apprenticed to a cabinet maker, and a few years later entered the itinerant ministry of the Methodist church. He studied at Miami university while preaching at Hamilton, Ohio, graduated at Cincinnati college, and soon afterward was appointed professor of languages in Augusta college, Ky. In 1831 he was elected chaplain of the United States senate, and in 1832 became editor of the "Christian Advocate and Journal." In 1834 he was elected president of Dickinson college at Carlisle, Pa., and during his incumbency made an extensive tour of observation in Europe and the East. As member of the

general conference of 1844 he was a prominent actor in the great contest on slavery which divided the church. Retiring from his office in 1845, he was pastor of churches in Philadelphia, and was also presiding elder of the Philadelphia district. He was secretary of the missionary society from 1850 to 1872, when he retired in consequence of physical infirmity. To his labors is largely due the establishment of missions in India, Bulgaria, western and northern Europe, and many parts of the United States, and the reinvigoration of those in China and elsewhere; while through his plans the annual contributions have increased from \$100,000 to \$600,000. In 1867 he again visited Europe in the interest of missions. Besides numerous contributions to periodical literature, Dr. Durbin has published "Observations in Europe, principally in France and Great Britain" (2 vols. 12mo, New York, 1844), and "Observations in Egypt, Palestine, Syria, and Asia Minor" (2 vols. 12mo, 1845).

**DÜREN**, a town of Rhenish Prussia, on the river Roer, 18 m. E. of Aix-la-Chapelle; pop. in 1871, 12,850. It has an asylum for the blind, and considerable manufactures of cloth, carpets, steel and iron ware, and paper. Under the Carolingians Düren was a town of importance, and councils were held there in 761 and 779. Charles V. captured and burned the town in 1543.

**DÜRER, Albrecht**, or **Albert**, a German painter and engraver, born in Nuremberg, May 20, 1471, died there, April 6, 1528. His father was a Hungarian goldsmith settled in that town. When 15 years old he was placed with Michael Wohlgemuth, the leading painter of Nuremberg. With him he remained four years, after which he travelled through Germany and the Low Countries, employing several years in the study not merely of his own art but of the most important collateral branches. He returned to Nuremberg in 1494, and soon after contracted a marriage which, according to the received tradition, was very unhappy. His earliest well authenticated picture bears the date of 1498, and is a portrait of himself. A similar portrait, dated 1500, and now in the Pinakothek at Munich, represents a man in the prime of life, standing in a dignified attitude, his hair falling over his shoulders. In his last portrait, a woodcut of the year 1527, the face is marked by lines of care, and the head is shorn of the flowing locks in which the artist was wont to take a complacent pride. In 1498 appeared his first great series of woodcuts, illustrating the Revelation of St. John; a work of singular power, in which the artist's imagination, however, is controlled by the fantastic element which then pervaded German art. At the close of 1505, by the aid of his friend Willibald Pirckheimer, Dürer made a journey to northern Italy, and remained a considerable time at Venice, Bologna, and other places; but so firmly was he grounded in his peculiar style, that the graceful productions of the

Italian schools had no influence upon him. From the time of his return to Nuremberg, in 1507, ensued a period of singular artistic activity, and among the great works which he then produced are the paintings of the "Martyrdom of the 10,000 Saints," at Vienna; the "Assumption of the Virgin," burned at Munich; the "Adoration of the Trinity," at Vienna; "Christ taken from the Cross," at Nuremberg; and the "Adoration of the Magi," at Florence; the woodcut series of the "Greater Passion" and "Lesser Passion," the "Life of the Virgin," and the "Triumphal Arch of the Emperor Maximilian;" the copperplate engravings of "The Knight, Death, and the Devil," "Melancholy," and "St. Jerome;" and portraits of his friends Pirkheimer, Melanchthon, and Erasmus. The print of "The Knight, Death, and the Devil" suggested to Fouqué his tale of "Sintram and his Companions." It is supposed that the woodcuts which pass under Dürer's name were cut by engravers from his drawings on the wood. He was very prosperous, and enjoyed the friendship of many of the most learned men of the day. The people of his native town delighted to honor him, and for many years he was one of its chief burghers. The emperors Maximilian I. and Charles V. successively appointed him court painter, and the chief cities of Germany were emulous for the possession of his works. In 1520 Dürer made a second journey to the Netherlands, and under the influence of this visit his subsequent works exhibit a soberer feeling and a refinement of his exuberant fancy. In 1526 were produced his two pictures containing life-size figures of the apostles John and Peter, and Mark and Paul, which were among his last, as they are generally esteemed his grandest works, and which he presented to the council of his native city. At this time Dürer had embraced the doctrines of the reformation, and these paintings are supposed to have conveyed the artist's exhortation to his countrymen to stand firm in the new faith.—As an engraver and a painter Dürer was one of the most remarkable men of an age prolific of great artists. In painting, he raised German art to an excellence which passed away with him; he found engraving in its infancy, and carried it to a perfection never since surpassed; he cultivated architecture and sculpture, and wrote valuable treatises on geometry and fortification, with a purity of style evincing a profound knowledge of the German language. He was the first German artist who taught the rules of perspective, and insisted on the study of anatomy. He rejected the classic ideal, which Raphael and his contemporaries had so successfully realized. Hence his strange attitudes, his fanciful draperies, his over-elaborate costumes and accessories, and the Gothic element which seems to pervade all his works. His wonderful creations, nevertheless, surprised and delighted the Italians. Raphael had the highest admiration of his genius, and

sent him a drawing executed by his own hand. The memory of Dürer is held in great veneration by the people of Nuremberg, who preserve his house with religious care. On the 300th anniversary of his birth the corner stone of a monument to his memory was laid there; and in May, 1840, the work was completed by the addition of a bronze statue of the artist by Rauch.—See Charles Narrey, *Albert Durer à Venise et dans les Pays-Bas* (illustrated, Paris, 1866); A. von Eye, *Albert Durer* (Nördlingen, 1867); Mrs. Heaton, "History of the Life of Albert Durer of Nuremberg" (London, 1869); William B. Scott, "Life and Works of Albert Durer" (London, 1869). A collection of his engravings has been reproduced under the care of Kaulbach (14 numbers, Nuremberg, 1857-'61).

**DURESS** (law Lat. *durities*; Fr. *duresse*), in law, the constraint by means of which a person is forced to act against his will. Duress is either of imprisonment, which must be either without lawful process, or by abuse of lawful process for an unlawful purpose; or it is *per minas*, where the compulsion is through fear of personal injury. Duress is admitted as a defence to a criminal charge only under several important restrictions. 1. It is not in general a justification for a felony, but only for the lesser offences called misdemeanor. 2. There must be apprehension of danger such as might reasonably be entertained by a person of ordinary courage; though in determining this, the age, sex, health, temperament, &c., of the person are important elements to be considered. 3. The injury threatened must be such as to endanger life or limb, and not of personal chastisement merely, or of injury to reputation or property. 4. Command by a father or master is not a justification to a child or servant for the commission of a crime; yet the wife was by the common law held to be in the power of the husband so far that what was done by her in his presence was deemed to be done under duress, and was a justification even for capital offences, except treason and murder. This was upon the legal presumption that if the husband was present the wife acted by his coercion; still greater would be her claim to exemption if actual coercion could be proved. There was, however, a singular inconsistency in not allowing the same excuse on the ground of coercion, actual or presumed, in respect to mere misdemeanors. It has been plausibly suggested that the reason of this anomaly was that the wife was not entitled to the benefit of clergy, while the husband was so entitled; and as he could therefore escape from punishment for certain offences, but the wife was subject to the penalty, the law humanely interposed and relieved her from all legal liability in cases where husband and wife were jointly chargeable, but in which a claim to benefit of clergy was allowed, and this privilege did not apply to misdemeanors, nor to murder or treason.—As a defence to contracts,

duress is admitted with much greater liberality. In general any contract entered into under duress of imprisonment, and in order to obtain relief therefrom, may be avoided for the compulsion; a reasonable fear of unlawful injury to one's person or reputation, or of destruction to one's property, may also constitute a valid defence; and in some cases it has been held that fear of unlawful imprisonment is legal duress, and that even detention of goods may be sufficient to avoid one's contract where he has no other speedy means than the giving of the contract for obtaining possession of them.

**DURFEE, Job**, an American author and jurist, born in Tiverton, R. I., Sept. 20, 1790, died there, July 26, 1847. He graduated at Brown university in 1813, studied law, and in 1820 was chosen representative in congress, where he served during two terms. For several terms he was a member of the state legislature, and in 1828 speaker of the house of representatives. In 1833 he was appointed associate justice of the supreme court of Rhode Island; and in 1835 he became chief justice, an office which he held until his death. In 1832 he published a poem in nine cantos, entitled "What Cheer," an account of the departure of Roger Williams from Salem, his adventures in the wilderness, and the settlement of Rhode Island. He also wrote a philosophical treatise called "Panidea," to prove the pervading influence and presence of God throughout nature. His works were collected and published with a memoir by his son (8vo, Providence, 1849).

**D'URFEY, Thomas**, a humorous English poet, born in Exeter about 1650, died in London, Feb. 26, 1723. He was of a French Protestant family which had fled from La Rochelle in 1628, when it was besieged by Louis XIII., and had settled in Exeter. Abandoning law for literature, he wrote ballads, sonnets, irregular odes, and more than 30 pieces for the theatre. The last were very successful; but as they are written in the licentious style prevalent after the restoration, they are not now represented upon the stage. He used to sing his own songs, and counted among his patrons King Charles II., Queen Anne, and even William III. His best known work, besides his plays, was a collection of songs and ballads, partly by himself, entitled "Wit and Mirth, or Pills to purge Melancholy" (6 vols. 12mo, London, 1719-'20).

**DURHAM**. I. A N. E. county of England, bordering on the North sea and on the counties of Northumberland, Cumberland, Westmoreland, and York, bounded N. partly by the river Tyne and S. by the Tees; area, 973 sq. m.; pop. in 1871, 685,045. Its general aspect is mountainous, particularly in the western part, where it is traversed by branches of a range of hills which has been called the English Apennines. From these several ridges shoot off, and some of them, projecting as far as the sea, terminate in tall cliffs and headlands. The rivers Tyne, Tees, and Wear are

navigable for a considerable part of their course, and have important towns and tolerable harbors at their mouths. The valley of the Tees, particularly near its estuary, has much alluvial soil, under careful cultivation, or devoted to pasturage. Here the famous Durham cattle are most extensively reared. Scarcely less celebrated are the Teesdale sheep, more highly prized than any other English breed. In the table lands of the western part, where cultivation is not attempted, are rich veins of lead; and east of this district is the Newcastle coal region, the most extensive in Great Britain. Iron, firestone, and millstone are also found in large quantities. Limestone, some of it peculiarly excellent, underlies a large portion of the county. Numerous railways and navigable rivers facilitate transportation. The principal manufactures are iron work, pottery, glass, coal, tar, salt, linen, and woollen. With the exception of the groves attached to country seats of the nobility, and some portions of the vale of Derwent, there is little woodland. Durham was formerly a county palatine, the bishop possessing regal rights within its borders; but his jurisdiction was transferred to the crown in the reign of William IV. The county consists politically of two divisions, each of which sends two members to the house of commons. II. An episcopal city and parliamentary borough, capital of the county, built on seven small hills, and nearly encompassed by the river Wear, which is here crossed by several bridges, 60 m. N. N. W. of York; pop. in 1871, 14,406. The river banks are skirted by plantations, hanging gardens, and beautiful public walks, beyond which the houses rise one above another, until they are crowned by the grand cathedral and an ancient Norman castle, on the summit of a rocky eminence. The division between the cathedral and the river has many elegant residences. The old town, N. of the castle, contains most of the shops, and a market place with a fountain. Among the public buildings and institutions are a town hall in the Tudor baronial style, a number of schools, an infirmary, hospitals, reading rooms, libraries, assembly rooms, a theatre, seven parish churches, various chapels, a school of art, and a university. A college was founded here as early as 1290 by the prior and convent of Durham, which was afterward enlarged, and under Henry VIII. was transferred with all its endowments to the dean and chapter. The present university was opened in 1833, and incorporated in 1837. It has two colleges, University and Bishop Hatfield's hall, instituted in 1846 for divinity students. The cathedral was founded in 1093. Its length, including the western porch, is 507 ft., its greatest breadth 200 ft., and it has a central tower 214 ft. high, besides two low towers, once surmounted by spires. The predominant style is early Norman, but in the various additions are specimens of the different styles which had prevailed in England up

to the close of the 14th century. The Galilee chapel at its W. end, built by Bishop Pudsey in the 12th century, contains the remains of the Venerable Bede; those of St. Cuthbert, patron of the church, rest in the chapel of the nine altars. The old church of St. Nicholas, partly repaired and partly rebuilt in 1858, is one of the finest specimens of modern church architecture in the north of England. Opposite

the cathedral stands the castle, founded by William the Conqueror for the purpose of maintaining the royal authority in the adjoining districts and protecting the country from the inroads of the Scots. Many additions have been made to it, and it is doubtful whether any part of the original keep, except the foundation, now remains. For many years it was the residence of the bishop, but of late it has

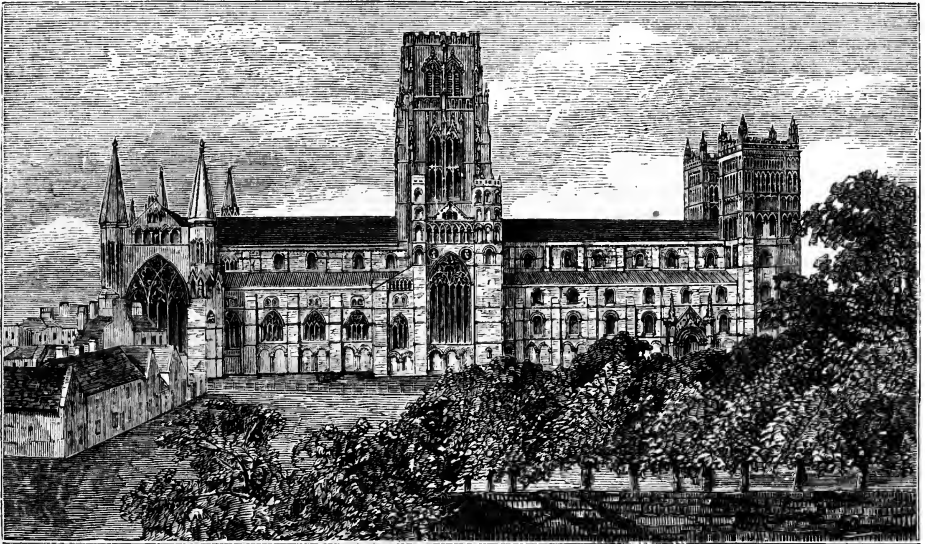

Durham Cathedral, north side.

been given up to the uses of the university. The see of Durham was long the richest in England, and for the three years ending with 1831 the average annual net revenue of the bishop was £19,066; but in 1836 his income was fixed at £8,000, the surplus being added to the incomes of poorer bishops.—The opening of collieries and construction of railways has given a powerful impetus to the trade and population of Durham. It has manufactories of carpeting and mustard. By the Great North of England railway it is connected with Newcastle-upon-Tyne, and by the Newcastle and Tyne railway with the W. coast. In the vicinity are Neville's Cross, erected by Lord Neville in commemoration of the defeat of David II. of Scotland in 1346, and the site of a Roman fortress, called the Maiden castle.

**DURHAM**, John George Lambton, earl of, an English statesman, born at Lambton Castle, county of Durham, April 12, 1792, died at Cowes, Isle of Wight, July 28, 1840. He was educated at Eton, served a short time in a regiment of hussars, and was returned to parliament in 1813, where he was one of the most liberal members of the whig party. During the reform excitement of 1819 he advocated the cause of the people, not only in parliament, but in public meetings. He was one of the

defenders of Queen Caroline, and in 1821 promulgated a scheme of parliamentary reform, which, though then unsuccessful, was embodied in the reform act ten years later. In 1826 his feeble health compelled him to relax his labors; he passed a year in Naples, and on his return was raised to the peerage as Baron Durham. He was lord privy seal in Earl Grey's ministry of 1830, and was one of the four who prepared the reform bill of the ensuing year, and the duty of defending this and the succeeding bills in the house of lords devolved upon him. In 1833 he retired from the cabinet, and was made an earl. In 1836-'7 he was ambassador to Russia. In 1838 he was sent with extraordinary powers as governor general to Canada, then in a state of rebellion; but returned in December, 1839, in consequence of a disagreement with the home ministry. He prepared an elaborate report on Canadian affairs, setting forth liberal principles of colonial government, and proposing the union of the two provinces.

**DÜRINGSFELD**, Ida von, a German authoress, born at Militsch, Lower Silesia, Nov. 12, 1815. She early became proficient in modern languages and literature, and in music, and commenced her literary career at the age of 15 by writing for a Breslau journal. Her first works



were *Gedichte* (1835), and a series of romances, *Der Stern von Andalusien* (1838), issued under the name of "Thekla." In 1841 she published at Breslau her *Schloss Goczyn*. This and other publications previous to her marriage with Baron Otto von Reinsberg, in 1845, appeared anonymously, but subsequently her writings have been published under her family name. Among her romances of "high life" are *Skizzen aus der vornehmen Welt* (1842-'5), *Graf Chala* (1845), *Esther* (1854), *Clotilde* (1855), *Milena* (1863), and *Die Literaten* (1863). Her historical romances are *Margaretha von Valois und ihre Zeit* (1847), and *Antonio Foscarini* (1850). Among her poetical publications are collections entitled *Für Dich* (1851), and *Amimone* (1852). In the *Böhmische Rosen* (1851) and *Lieder aus Toscana* (1855) she translated the folk songs of the Czechs and Tuscans. As the result of her travels appeared a series of sketches, among which is *Aus Dalmatien* (3 vols., Prague, 1855-'7). During a residence in Belgium she collected the materials for a work entitled *Von der Schelde bis zur Maas* (3 vols., Leipsic, 1861), in which she illustrated the intellectual progress of the Flemish people since 1830. She also wrote a work on proverbs, *Das Sprichwort als Kosmopolit* (3 vols., Leipsic, 1863).

**DURIO**, a fruit tree of the Indian archipelago, of the family *sterculiaceae*, the only known species of its genus (*D. zibethinus*). It attains a height of 80 ft., and in general appearance is like the elm. The leaves are entire, oblong, rounded at the base, and taper to a long point; their color is silvery red. The flowers are yellowish green, and grow in little clusters on the main branches. The fruit, known as the durian, is sometimes round, sometimes oval, 9 or 10 inches in longest diameter. It has a thick hard rind, covered with sharp strong prickles; it is divided into five cells, each containing from one to four seeds as large as pigeons' eggs; and a luscious cream-colored pulp which envelops these is the part that is eaten. It has a delicious flavor, though a repulsive odor, and commands the highest price of any fruit in the Indian markets. The seeds are often roasted and eaten; they taste like chestnuts. The durio is cultivated in Ceylon; each tree yields about 200 durians in a season.

**DÜRKHEIM**, a town of Rhenish Bavaria, on the Isenach, 15 m. N. W. of Spire; pop. in 1871, 5,572. The principal trade is in corn and wine; there are glass works and a paper mill. In the vicinity are the salt works of Philippsahl, with three saline springs. The place is chiefly remarkable as a resort of invalids who take the grape cure. In the environs are the ruins of the abbey of Limburg and of the castle of Hartenburg. On the summit of the Kastanienberg is a rampart known as the *Heidenmauer* or pagan's wall (the scene of Cooper's novel of this name), said to have been a Roman camp. Turenne here defeated the imperialists in 1674.

**DURLACH**, a town of Baden, at the foot of the Thurmberg, and on the right bank of the Pfalz, 4 m. E. of Carlsruhe; pop. in 1871, 6,327. It contains a fine castle, a parish church with an excellent organ, a quaint old town hall, and a statue of the margrave Charles II. in the market place. Linens, tobacco, chicory, and fruits are produced here. It was the residence of the margraves of Baden-Durlach from 1565 to 1771, when that line became extinct.

**DUROC, Gérard Christophe Michel**, duke of Friuli, a French general, born at Pont-à-Mousson, near Nancy, Oct. 25, 1772, killed near Markersdorf, Saxony, May 22, 1813. He served in the first wars of the revolution as adjutant of Gen. L'Espinasse, joined the army of Italy in 1796, became brigadier general in 1797, took part in the Egyptian campaign, and after Napoleon's return to France and the 18th Brumaire, in which he was a chief actor, he was made lieutenant general and governor of the Tuileries. He was employed on diplomatic missions to Stockholm, Copenhagen, St. Petersburg, Berlin, and Dresden; took part in the battle of Austerlitz as successor of Oudinot; and accompanied Napoleon in the campaigns of 1806 and 1807. In 1809 he was with the emperor in Austria, and negotiated the truce of Znaym. In 1812 he was in the Russian campaign, always enthusiastically devoted to the cause of Napoleon, of whom he was a great favorite. After the battle of Bautzen, while escorting the emperor to an elevation adjoining the battle ground, he was struck by a cannon shot. The farm house in which he died was purchased by Napoleon, who caused a monument to be erected there to Duroc's memory. His remains were removed in 1845 to the church of the Invalides in Paris.

**DURUY, Victor**, a French historian, born in Paris, Sept. 11, 1811. He was successively professor of history at colleges in Rheims and Paris, was made doctor of letters in 1853, and afterward inspector of the academy of Paris, inspector general of secondary instruction, and professor of history at the polytechnic school. In 1863 he became minister of public instruction, and in this position introduced many improvements and innovations, some of which excited great opposition. He retired in 1869, and became a senator. He is the author of numerous very popular works on ancient, mediæval, and modern geography and history, especially Greek, Roman, and French, several of which are included in a collection entitled *L'Histoire universelle*, edited by him. He also wrote important reports on the progress of literature and science as shown in the universal exposition of 1867.

**DUSSEK, John Louis**, a Bohemian composer and pianist, born at Czaslau, Feb. 9, 1761, died in Paris, March 20, 1812. His father, John Joseph Dussek, was organist and choir master at Czaslau, and he had learned to play the piano with much facility at the age of five.

He became a choir boy at the convent of Iglau, and there pursued the study of music. He afterward attended the university of Prague, receiving the degree of bachelor of philosophy, and commenced his professional life in Belgium as organist of the church of St. Rombaut at Mechlin. He resided also at Amsterdam and the Hague. In 1783 he went to Hamburg to consult Emanuel Bach, and receiving encouragement from him he took up his temporary residence at Berlin, and there excited much attention by his pianoforte playing. He went in turn during three succeeding years to Paris, to Milan, and to London, where he married and became a music publisher. In this he failed, and to avoid his creditors fled to Hamburg. After various wanderings he at last about 1807 settled in Paris, where he became concert master to Prince Talleyrand. He published 76 compositions. Those among them which he regarded as the best are known by the opus numbers 9, 10, 14, and 35. As a pianist he achieved a great distinction, and was among the first to make the piano popular at concerts. The instruments of this class were in his day very weak and imperfect, but by his broad style and great dexterity he overcame these disadvantages.

**DÜSSELDORF**, a city of Rhenish Prussia, capital of a district of the same name, at the confluence of the Düssel and the Rhine, 20 m. N. N. W. of Cologne; pop. in 1871, 69,351. Area of the district, 2,112 sq. m.; pop. 1,328,065. The city is a great focus of railway and steamboat communication, and much of the transit trade of the Rhine is carried on by its merchants. There are many carriage, tapestry, cotton, tobacco, and mustard manufactories, tanneries, and dyeing establishments. In 1288 Düsseldorf became a municipality. In modern times it has been successively under the dominion of Brandenburg and Neuburg, under French and Bavarian rule, and was for some time the capital of the duchy of Berg, until in 1815 it passed with the whole duchy under the sway of Prussia. It is divided into four sections, the Altstadt, the Karlstadt, the Friedrichstadt, and the Neustadt. The last was laid out by the elector palatine John William, whose statue adorns the market square and the palace yard. The Karlstadt derives its name from the elector Charles Theodore, its founder, who established in 1767 the academy of painting. The town possesses many delightful

parks, and the Hofgarten is one of the finest in Prussia. New and beautiful streets have been laid out within the last 25 years. The prominent public buildings are the former electoral palace, now the art academy, the town hall, the cabinet of antiquities and that of scientific instruments, the tribunals, the observatory, and the churches of St. Lambert and St. Andrew. Both churches contain monuments of the ancient sovereign princes of Düsseldorf. There are numerous charitable and literary associations, an academy of commerce, a good theatre, and a library of 50,000 volumes. The celebrated picture gallery, established here in 1690, was transferred to Munich in 1805. The collection of 14,500 drawings by the old masters, among which are several by Michelangelo, Raphael, Giulio Romano, Domenichino, and Titian, and of 24,000 engravings and casts, which formed part of the same gallery, still remains in Düsseldorf. Art has flourished here

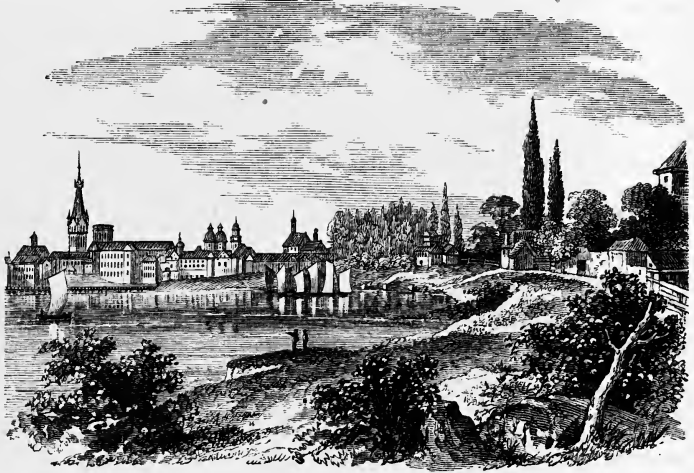

Düsseldorf.

more than in any other German town, especially since 1822, when Frederick William III. renovated the building of the academy, and when Cornelius, Schadow, and other artists of genius founded the Düsseldorf school of painters. The art union for Rhenish Prussia and Westphalia was founded here in 1828. The engravers' establishment of the royal academy of Schulgen-Bettendorf was removed from Bonn to Düsseldorf in 1837. In June, July, and August there is an exhibition of pictures by living artists. Besides the academy of painting, there is a school for painters and one for architects. A monument of Cornelius for this city was designed in 1874.

**DUTCH LANGUAGE AND LITERATURE.** See NETHERLANDS.

**DUTCHESS**, a S. E. county of New York, bounded W. by the Hudson river, and E. by Connecticut; area, 816 sq. m.; pop. in 1870, 74,041. The surface is uneven and in many

parts hilly. Fishkill river and Wappinger's creek supply water power, which is employed in a number of mills. Much of the soil is best adapted to grazing, but the cultivated portions are carefully improved and very fertile. Limestone, slate, marble, iron, and lead are the most important minerals. It has great facilities for communication by means of the Hudson river, the Hudson River and Harlem railroads, which intersect it, and the Dutchess and Columbia and the Poughkeepsie and Eastern railroads. The chief productions in 1870 were 87,921 bushels of wheat, 174,194 of rye, 509,608 of Indian corn, 700,100 of oats, 403,687 of potatoes, 136,554 tons of hay, 1,232,252 lbs. of butter, and 135,275 of wool. There were 10,397 horses, 27,209 milch cows, 16,732 other cattle, 35,422 sheep, and 13,540 swine; 19 iron works, 7 woollen mills, 1 cloth-printing establishment, 32 flour mills, 7 breweries, 7 tanneries, 7 currying establishments, 9 manufactories of agricultural implements, 7 of bricks, 6 of carpets, 27 of carriages and wagons, 11 of barrels and casks, 3 of cotton goods, 1 of dye stuffs, 2 of hats and caps, 1 of rubber goods, 5 of machinery, 10 of sashes, doors, and blinds, 20 of tin, copper, and sheet-iron ware, 20 of tobacco and cigars, and many others; in all there were 866 manufacturing establishments, with an aggregate capital of \$6,604,866. Capital, Poughkeepsie.

**DUTROCHET, René Joachim Henri**, a French physiologist, born at Néon, Poitou, Nov. 14, 1776, died in Paris, Feb. 4, 1847. His family was rich and noble; but its property having been confiscated during the revolution, he studied medicine in Paris, and served in the army as physician in the Spanish campaigns of 1808-'9. The rest of his life he passed chiefly on his estate in Touraine. He published researches upon the formation of the eggs in birds and fowls, the gradual unfolding of the allantois in the incubated egg, the increase of the young as the albumen diminishes, the structure and growth of feathers, the envelopes of the fœtus of mammalia and of the human fœtus, and the growth of vegetables and insects. His most remarkable achievement was the discovery of endosmosis in 1828, and in that year he published *Recherches sur l'endosmose et l'exosmose*. His principal writings were collected in 1837 under the title of *Mémoires pour servir à l'histoire anatomique et physiologique des végétaux et des animaux*; and in 1842 he published *Recherches physiques sur la force épiploïque*.

**DUTTEAH**, a town of India, capital of a state of the same name in the district of Bundelcund, lat. 25° 40' N., lon. 78° 31' E.; pop. over 40,000. It is nearly midway on the route from Agra to Saugor, 115 m. S. S. E. of the former. The town is in a narrow valley, between low rocky hills, and is surrounded by a wall 30 ft. high. The streets are narrow and crooked; but many of the houses, belonging to landholders of the neighborhood, are large and substantial. The

rajah's palace and pleasure ground of 10 acres are surrounded by a high wall. In the grounds is a reservoir with a fine fountain, around which eight sculptured elephants spout water.

**DUMVIRS**, among the ancient Romans, two officers appointed temporarily and for a particular purpose. They were therefore of various sorts, and were specially named from the nature of their functions. The *dumviri juri dicundo* were the highest magistrates of colonies and towns, where they had the rank of consuls at Rome. The *dumviri navales* had charge of the construction and equipping, and sometimes of the command of fleets. The *dumviri quinquennales* were the censors of municipal towns. The *dumviri sacrorum* had originally the charge of the Sibylline books. The *dumviri ludorum* in the Byzantine empire were functionaries elected for one year to the office of exhibiting games at their own expense to the people.

**DUVAL**. I. A N. E. county of Florida, bordering on the Atlantic, bounded N. by Nassau river and intersected by the St. John's; area, 430 sq. m.; pop. in 1870, 11,921, of whom 6,780 were colored. The surface is generally level. The Jacksonville, Pensacola, and Mobile, and the Florida railroads pass through it. The chief productions in 1870 were 32,737 bushels of Indian corn, 35,273 of sweet potatoes, and 17 hhd. of sugar. The total value of live stock was \$155,517. There were 2 brick yards, 10 saw mills, 1 ship yard, 2 manufactories of tin, copper, and sheet-iron ware, 1 of tar and turpentine, and 3 of jewelry. Capital, Jacksonville. II. A S. W. county of Texas, watered by affluents of the Rio Nueces, and by several streams that flow into the gulf of Mexico; area, 1,650 sq. m.; pop. in 1870, 1,083, of whom 3 were colored. Water and timber are scarce. The grass is good, and stock raising may be successfully pursued, but only along the streams is the land suitable for agriculture. In 1870 the total value of farm products was \$26,522, including 110,950 lbs. of wool. There were 2,622 horses, 4,472 cattle, and 34,325 sheep. Capital, Jacksonville.

**DUVAL, Valentin Jameray**, a French scholar, born in Champagne in 1695, died in Vienna in September, 1775. He was of humble parentage, and was employed in his boyhood as a herdsman, but found time for study. He accumulated about 200 books and a few maps, and one day was found in the midst of them by Leopold of Lorraine, who placed him under the instruction of the Jesuits of Pont-à-Mousson. Here he made rapid progress, and Duke Leopold took him to Paris in 1718, subsequently appointing him librarian and professor of history at the noblemen's academy of Lunéville. When Duke Francis Stephen, ceding Lorraine, became grand duke of Tuscany, he accompanied him as librarian to Florence. Here he resided for nearly ten years, until called to preside over the collection of coins and medals at Vienna, Francis Stephen having married Maria

Theresa and become emperor of Germany. His complete works, chiefly on numismatics, with a memoir, were published at Basel (with the imprint of St. Petersburg) in 1784, in 2 vols. 8vo, and at Paris in 1785, in 3 vols. 18mo.

**DUVERGIER DE HAURANNE. I. Jean**, a French theologian, born in Bayonne in 1581, died in Paris, Oct. 11, 1643. He was educated in theology at Louvain, where Jansenius was at the same time a student, with whom he formed an intimate friendship, and who accompanied him to Bayonne, but soon returned. Duvergier was appointed canon of Bayonne, and afterward of Poitiers and abbot of St. Cyran. His rigor and zeal becoming known, he was invited to Paris, where he made numerous disciples in all classes of society. He refused several bishoprics. His Jansenist principles brought upon him the enmity of the Jesuits, and in 1638 he was imprisoned at Vincennes by order of Richelieu, after whose death he was released, but did not long survive. His most celebrated writings are those which he directed against the Jesuit Garasse, Pascal, Arnauld, and Nicole were his disciples. **II. Prosper**, a French politician and author, descended from a brother of the preceding, born in Rouen, Aug. 3, 1798. He was for many years associated as a journalist with Guizot, Rémusat, and Rossi. In 1831 he was chosen to the chamber of deputies from Sancerre, and at first gave his support to the government of Louis Philippe, but became one of the prominent champions of reform. After the revolution of 1848 he represented the department of Cher in the constituent assembly, and in November, 1850, became a member of the legislative assembly. After the *coup d'état* of 1851 he was imprisoned, and then banished until August, 1852. His principal work is the *Histoire du gouvernement parlementaire en France* (7 vols., Paris, 1857-'65). He was elected a member of the academy in 1870.

**DUVERNOY, Georges Louis**, a French naturalist, born in Montbéliard, Aug. 6, 1777, died in Paris, March 1, 1855. He pursued his studies at Stuttgart, Strasburg, and Paris, and in 1802 was invited by Cuvier, to whom he was related, to assist in editing his treatise on comparative anatomy. With the aid of the notes and counsels of his master, he prepared the last three volumes of this work, embracing the organs of digestion, respiration, circulation, generation, and the secretions. For 20 years he practised medicine in Montbéliard, publishing only a few writings on fossils. In 1827 he was elected professor of natural history at Strasburg, where during ten years he published a variety of papers on anatomical subjects; and after the death of Cuvier he was engaged in arranging his papers for publication. In 1837 he was elected professor of natural history in the collège de France, and in 1850 was transferred to the chair of comparative anatomy. His numerous works have furnished important materials to anatomists and zoölogists.

**DUVEYRIER. I. Honoré Nicolas Marie**, baron, a French jurist and politician, born at Pignans, Provence, Dec. 6, 1753, died in May, 1839. He received a military education, but devoted himself to the law, and became a distinguished barrister. Louis XVI. sent him three days previous to his flight to Varennes on a mission to the prince de Condé, but he was detained for some time as a prisoner by the Austrians. Though elected on his return a member of the commune of Paris, he was put in prison at the instigation of Robespierre. After his release he was employed abroad as a commissioner for the supply of the French armies. In 1796 he resumed his practice in Paris, and was afterward general administrator of finance in Rome, acquiring a large fortune. He eventually became president of the court of appeal at Montpellier. His heroi-tragical comedy *La cour plénière* made a great sensation at the time of its publication (1775), and its authorship was long ascribed to Beaumarchais. His other principal work, in which his son Charles participated, is *L'Histoire des premiers électeurs de Paris en 1789*.

**II. Anne Honoré Joseph**, known as a dramatic author under the pseudonyme Mélesville, son of the preceding, born in Paris, Nov. 13, 1788, died there in 1865. He was originally a lawyer and magistrate, but after the restoration devoted himself to the drama. He wrote more than 300 plays, chiefly in conjunction with Seribe, and *Le chevalier de St. Georges* with Roger de Beauvoir. Among the best known comic operas of which he wrote the text is *Zampa*. **III. Charles**, brother of the preceding, born in Paris, April 12, 1803, died there, Nov. 10, 1866. He was an active St. Simonian, and organized branches of that sect in England and Belgium, wrote for Michel Chevalier's *Globe*, and was sentenced to one year's imprisonment for having published in that journal an article entitled *De la femme*. Subsequently he wrote plays with his brother and other authors. In 1855 he composed with Scribe the text of Verdi's "Sicilian Vespers." **IV. Henri**, son of the preceding, an explorer of Africa, born in Paris, Feb. 28, 1840. He completed his education in Germany, became acquainted with the traveller Barth, qualified himself for explorations by special studies in Paris, was in Africa in 1857 and 1859, and published *Exploration du Sahara* (2 vols., Paris, 1864 *et seq.*), besides contributions to periodicals and to the French and German geographical societies. He served in the French army in 1871, and was for some time a prisoner of war in the German fortress of Neisse.

**DUXBURY**, a town of Plymouth co., Massachusetts, on the N. shore of Plymouth harbor, at the terminus of the Duxbury and Cohasset extension of the South Shore railroad, 27 m. S. S. E. of Boston; pop. in 1870, 2,341. The N. E. boundary of the harbor is a peninsula, about 6 m. long, called the Gurnet. Near its extremity are two fixed lights. Duxbury is the terminus of the Atlantic telegraphic cable

laid in 1869 from Brest, France, via St. Pierre. In the S. part of the town is Standish or Captain's hill, 180 ft. high, commanding a fine view of the sea. It was the residence of Miles Standish, to whose memory a monument was erected in 1872. The inhabitants are chiefly engaged in commerce, fishing, and ship building. There are 10 schools, including a high school and an academy, and several churches.

**DUYCKINCK. I. Evert Augustus**, an American author, born in New York, Nov. 23, 1816. He is a son of Evert Duyckinck, for many years a leading bookseller and publisher of New York. He graduated at Columbia college in 1835. In 1840 he commenced, with Cornelius Mathews, a monthly periodical entitled "Arcturus," which was continued till 1842. In 1847 he commenced the "Literary World," a weekly critical journal; he withdrew from the editorship with the publication of the 12th number, but resumed it on the appearance of the 88th, in connection with his younger brother George; and the periodical remained under their joint management until its discontinuance at the close of 1853. In 1856 the two brothers completed the "Cyclopædia of American Literature" (2 vols. large 8vo), to which the elder brother added a supplement in 1865. He has also published "The Wit and Wisdom of Sydney Smith," with a memoir (1856); "Poems relating to the American Revolution," with memoirs (1865); "History of the War for the Union" (3 vols., 1861-'5); "National Portrait Gallery of Eminent Americans" (2 vols., 1866); "History of the World from the Earliest Period to the Present Time" (1870); "Memorials of John Allan" (1864); and "Memorials of Francis L. Hawks" (1871). He has also contributed largely to periodical literature. **II. George Long**, brother of the preceding, born in New York, Oct. 17, 1823, died there, March 30, 1863. He graduated at the university of New York in 1843. Besides his share in the editorial conduct of the "Literary World" and in the preparation of the "Cyclopædia of American Literature," he published "George Herbert of Bemerton" (1858), and lives of Bishop Thomas Ken (1859), Jeremy Taylor (1860), and Latimer (1861).

**DUYSE, Prudens van**, a Flemish poet, born at Dendermonde about 1805, died in Ghent, Nov. 13, 1859. He was professor of national history in the atheneum of Ghent, and archivist of the city, and contributed to the preservation of the Flemish dialect by his poems. He published *Vaterlandsche poëzij* (1839), *Het klaverblad* (1848), and *Dichtbespiegeling* (1849). He was also the author of several essays on the history and literature of the Netherlands.

**DWARACA, Dwarka**, or **Jigat**, a town of Guzerat, Hindostan, on the coast, near the western extremity of the peninsula of Cattywar, 270 m. W. of Baroda. It is fabled to have been the residence of Krishna, and contains several pagodas, the principal of which is the most celebrated temple of Krishna in India, with

a spire 140 ft. high, consisting of a series of pyramids. It is annually resorted to by 15,000 pilgrims. It contains about 2,500 houses, and has an important trade in chalk.

**DWARF** (Sax. *duerg*, *dueorg*), an animal or a plant that does not attain the ordinary size of its species. A degree of dwarfishness may be the general result of natural causes, as of excessive cold, since both plants and animals diminish in stature toward the poles; or it may be produced by artificial means. The Chinese have the art of dwarfing trees by diverting the growth from the foliage to the flowers and fruit. The ancients are said to have produced artificial dwarfs of the human race, who were highly esteemed by the Roman matrons for servants. During the middle ages dwarfs shared with fools the favor of courts and of the nobility, and a salary for the king's dwarf was not abolished in France till the reign of Louis XIV. A race of dwarfs, perhaps the pigmies of the ancients, has been said to exist in the interior of Africa; and Du Chaillu in his "Country of the Dwarfs" gives a curious account of a dwarfish race which he found in equatorial Africa. Symmetrical dwarfs are rare and remarkable phenomena. One of the most noted of those whose history is certain was the Polish gentleman, Count Borowlaski or Boruslawski (1739-1837). At 1 year of age he was 14 inches high; at 6, 17 in.; at 10, 21 in.; at 15, 25 in.; at 20, 28 in.; at 25, 35 in., which was nearly his greatest height. He early displayed wit and grace, and was taken into the family of the countess Hlumiecka, with whom he frequented the Prussian court. At the age of 40 he married, became a father, and, after giving concerts in the principal cities of Germany, visited England. In London he published his memoirs (8vo, 1788), and he afterward lived in elegant retirement in Durham. In contrast with him was the favorite dwarf of the ex-king Stanislas of Poland, commonly called Bébé (1741-'64). He was a native of Lorraine, and at 5 years of age was 22 in. high; at 15, 29 in.; and at his death, 33 in. His diminutive figure was well formed and justly proportioned till after the age of puberty, when his spine curved and he became decrepit. He was once visited by the count Borowlaski, and, having noticed the superiority of the latter in manners and intelligence, watched for an opportunity and attempted to throw his visitor into the fire. The Dutch dwarf, Wybrand Lolkes, born in 1730, possessed mechanical taste and skill, had success as a watchmaker, and when 60 years of age was 27 in. high and weighed 56 lbs. Mme. Teresia, called the Corsican fairy from the place of her birth (1743), was remarkable for physical symmetry and beauty, and mental vivacity. She spoke several languages, was charming in conversation, and when exhibited in London in 1773 was 34 in. high and weighed 26 lbs. Jeffery Hudson (1619-'82) was the favorite dwarf of Charles I. of England. He was a native of

Oakham, and about the age of 7 years, when 18 in. high, was taken into the service of the duke of Buckingham. From the age of 7 to 30 he grew no taller, but afterward shot up to 3 ft. 9 in. He was served up in a pie at a royal entertainment, from which he suddenly sprang forth in full armor. Sir William Davenant wrote a poem called "Jeffreidos" on a battle between him and a turkey cock, when a woman rescued him from his furious antagonist. The courtiers teased him about the story till he challenged a young gentleman, Mr. Crofts, who had affronted him. That gentleman appeared at the rendezvous armed only with a squirt, which so enraged the dwarf that a real duel ensued. The combatants were on horseback, and at the first fire Jeffery shot his antagonist dead. He was afterward taken prisoner by a Turkish rover, and was for a time a slave in Barbary. At the beginning of the civil war he was made captain in the royal army, but he closed his life in prison, into which he had been cast shortly before his death on suspicion of being privy to the popish plot. Charles I. of England attended the marriage of Richard Gibson and Anne Shepherd, each of whom measured 3 ft. 10 in. Waller wrote a poem on the occasion, and Sir Peter Lely painted the couple at full length. Gibson rose to celebrity as a painter. In 1710 Peter, czar of Russia, celebrated a marriage of dwarfs with great parade. All the dwarf men and women within 200 miles, numbering about 70, were ordered to repair to the capital. He supplied carriages for them, and so managed that one horse should be seen galloping into the city with 12 or more of them. All the furniture and other preparations were on a miniature scale. Gen. Tom Thumb (Charles S. Stratton), the celebrated American dwarf, was born in Bridgeport, Conn., in 1837, and at the age of 5 years was not 2 ft. in height and weighed less than 16 lbs.; and he had grown but very little for three or four years. He had fine talents, and was remarkable for agility and symmetry, while his lively sense of the ludicrous gave him excellent success in performances suited to his character. In 1842 he was exhibited in New York, his age being announced as 11 years. He visited England in 1844, was several times exhibited to the queen and court at Buckingham palace, gave levees, and was invited to parties of the nobility. In Paris he gained applause as an actor. He returned to the United States in 1847, and was exhibited in the principal cities of the United States and in Havana. He again visited England in 1857. In 1863 he married Lavinia Warren (born at Middleboro', Mass., Oct. 31, 1842), also a dwarf, who had been placed on exhibition in 1862. Since their marriage they have travelled extensively in the United States and Europe.

**DWIGHT, Edmund**, an American merchant, born in Springfield, Mass. Nov. 28, 1780, died in Boston, April 1, 1849. He graduated at Yale college in 1799, and studied law. In 1815

he founded in Boston a mercantile house which afterward built up the manufacturing villages of Chicopee Falls, Cabotville, and Holyoke. He was the first to propose the establishment of normal schools in Massachusetts, to secure which, in 1838, he pledged \$10,000 provided the state would appropriate a like sum, which was accepted by the legislature.

**DWIGHT, John Sullivan**, an American author and critic, born in Boston, Mass., May 13, 1813. He graduated at Harvard college in 1832, and studied theology in the divinity school at Cambridge. In 1840 he was ordained as pastor of the Unitarian congregation in Northampton, Mass., where he remained but a short time, relinquishing the ministry to devote himself to literature, and especially to musical criticism. In 1838 he published, in Ripley's "Specimens of Foreign Standard Literature," "Translations of Select Minor Poems from the German of Goethe and Schiller, with Notes." His translations are distinguished for their graceful diction, and not less for their conscientious adherence to their originals, and especially for their musical rhythm. Subsequently he delivered lectures in many cities upon Bach, Beethoven, Handel, Mozart, and other great composers, which did much to awaken popular attention to what is called classical music, and to develop the love and appreciation of it in this country. He also contributed many articles to the "Christian Examiner," the "Dial," the "Harbinger," and other periodicals, and musical critiques of a far higher character and range of thought than were then common to the newspapers of the day. He was one of the founders of the Brook Farm association, where he resided for nearly seven years. In April, 1852, he commenced in Boston the publication of "Dwight's Journal of Music," an independent journal of criticism of music, art, and literature, which is still in existence.

**DWIGHT, I. Timothy**, an American divine and scholar, born in Northampton, Mass., May 14, 1752, died in New Haven, Conn., Jan. 11, 1817. From his earliest years, under the training of his mother, a daughter of Jonathan Edwards, he gave indications of a thirst for knowledge and great facility of learning. He is said to have been able at the age of four to read the Bible correctly and fluently. He graduated at Yale college in 1769, and took charge of a grammar school in New Haven, where he remained for two years. From 1771 to 1777 he was a tutor in Yale college; in the latter year, when on account of the revolutionary troubles the students of the college were dispersed, he went with his class to Wethersfield, where he remained till autumn, and in the mean time was licensed to preach by an association in Hampshire co., Mass. Soon after this he was appointed chaplain to a brigade of the division under Gen. Putnam, and joined the army at West Point, where he remained for more than a year, not only laboring for the spiritual interests of the soldiers;

but heightening their enthusiasm by addresses and by patriotic songs, the principal of which was entitled "Columbia." By the death of his father in 1778 the support of his mother with 12 children devolving on him, the oldest of her sons, he resigned his chaplaincy and removed with his family to Northampton. Here he worked with his own hands on the farm, supplied some neighboring church on the Sabbath, established and sustained a school for both sexes, represented the town in 1781 and 1786 in the state legislature, and would have been chosen to the continental congress, but declined the intended honor in order to devote himself to the work of the ministry. In 1783 he was ordained pastor of the Congregational church at Greenfield Hill, Fairfield, Conn.; but as his salary was insufficient for his support, he established an academy, to which he devoted six hours of each day. In 1787 he received the degree of D. D. from the college of New Jersey, and in 1810 that of LL. D. from Harvard college. On the death of Dr. Stiles he was chosen his successor as president of Yale college, was inaugurated in September, 1795, and held the office until his death. In addition to its appropriate duties he performed a vast amount of labor belonging to other departments. He was in reality professor of belles-lettres, oratory, and theology, teaching a class preparing for the ministry, and preaching in the college chapel twice every Sunday; in the discharge of which latter duty he prepared and delivered in a series of discourses his well known system of theology. During several years he spent his vacations in travelling through New England and New York, making extensive notes and critical observations on the manners of the time, which were afterward published and have a permanent value. Dr. Dwight was a man of commanding presence, of dignified but affable manners, of striking conversational powers, of superior intellectual faculties, untiring in his industry and research, of great system and wonderful memory; as a teacher, remarkable for his skill and success; as a writer, interesting and sensible; and as a preacher, sound, strong, impressive, and at times highly eloquent. The literary labors of Dr. Dwight were very great, and his publications numerous, including dissertations, poems, and occasional sermons, issued during his life, and since his death; "Theology Explained and Defended," with a memoir (5 vols., 1818), often reprinted in this country and in England; "Travels in New England and New York" (4 vols., 1822); "Sermons on Miscellaneous Subjects" (2 vols., 1828). Among his poetical works are "The Conquest of Canaan" (1785), an epic poem in 11 books, finished in 1774, and "Greenfield Hill" (1794). **II. Sereno Edwards**, an American clergyman, son of the preceding, born at Greenfield Hill, Fairfield, Conn., May 18, 1786, died in Philadelphia, Nov. 30, 1850. He graduated at Yale college in 1803, and was tutor there from 1806 to 1810,

during which time he studied law in New Haven, and was admitted to the bar in the latter year. He practised till 1815, when he gave up law for theology, and in October of the year following was licensed as a preacher. He was chaplain of the United States senate for the session of 1816-'17, and in September of the latter year was ordained pastor of the Park street church, Boston, where he remained for ten years. Ill health obliged him to resign his charge in 1826, when he returned to New Haven, and occupied himself in writing the life and editing the works of the elder President Edwards, which were published in 1829. In 1828, in connection with his brother Henry, he opened in New Haven a school for boys, on the plan of the German gymnasiums, which was continued for three years. In March, 1833, he was chosen president of Hamilton college, N. Y., and the same year he received the degree of D. D. from Yale college. In 1835 he resigned his presidency, and in 1838 removed to New York, where sickness disabled him for active service. He died while on a visit to Philadelphia for medical advice. He published at various times several sermons and addresses, "The Life of Brainerd" (1822), a volume on the "Atonement" (1826), "Life of Edwards" (1830), and "The Hebrew Wife" (1836). A volume of his "Select Discourses" was published in 1851, together with a memoir by his brother, the Rev. Dr. W. T. Dwight. **III. William Theodore**, an American lawyer and clergyman, brother of the preceding, born at Greenfield Hill, Fairfield, Conn., June 15, 1795, died at Andover, Mass., Oct. 22, 1865. He graduated at Yale college in 1813, was a tutor there from 1817 to 1819, and was admitted to the bar in Philadelphia in 1821. After practising his profession for ten years he studied theology, and in 1832 became pastor of the third Congregational church in Portland, Maine, which position he held till May, 1864. He was one of the most prominent and influential ministers in Maine, and a popular preacher. He published in 1851 a memoir of the Rev. Sereno Edwards Dwight, and was the author of many addresses and reviews. **IV. Theodore**, an American lawyer, author, and journalist, brother of Timothy Dwight, born in Northampton, Mass., Dec. 16, 1764, died in New York, June 11, 1846. He studied law with his uncle, Judge Pierpont Edwards of Hartford, Conn., became eminent in his profession, and a leading speaker and writer of the federal party. He was for several years a senator in the Connecticut legislature, a representative in congress from that state in 1806-'7, and editor during the war of 1812-'14 of the "Hartford Mirror," the leading organ of the federal party in the state. During the session of the Hartford convention in 1814 he acted as its secretary, and in 1833 published a "History of the Hartford Convention," written from a strong federal point of view. From 1815 to 1817 he edited the "Albany Daily Ad-

vertiser," and in the latter year removed to New York, where he established the "New York Daily Advertiser," of which he remained the editor till 1836, when he retired to reside in Hartford. Three years before his death he returned to New York. In 1839 was published his "Character of Thomas Jefferson as exhibited in his own writings," a book intensely partisan. He was also the author of a "Dictionary of Roots and Derivations," and of several other educational works. **V. Theodore**, an American author, son of the preceding, born in Hartford, March 3, 1796, died in Brooklyn, N. Y., Oct. 16, 1866. He graduated at Yale college in 1814, and intended to study for the ministry, but was attacked with hæmorrhage of the lungs and ordered abroad by his physician. After travelling over the greater part of Europe, he published in 1824 "A Tour in Italy." In 1833 he removed to Brooklyn and engaged in many public and philanthropic enterprises. He assisted his father in editing the "Daily Advertiser," was for a time editor and publisher of the "New York Presbyterian," and contributed to most of the principal magazines and other periodicals. He was a man of great cultivation, conversing with ease in the French, Italian, Spanish, and Portuguese languages, and having a good knowledge of German, Greek, Hebrew, and Arabic. At the time of his death, which was caused by a railroad accident, he was engaged in translating American works of instruction into Spanish, with the purpose of introducing them into the Spanish American countries. He was the author of a "History of Connecticut" (1841), "The Northern Traveller" (1841), "The Roman Republic of 1849" (1851), "Life of Garibaldi" (1859), and of a number of educational works.

**DWINA**, or **Dvina**, **Northern**, a river of Russia in Europe, formed in the government of Vologda by the junction of the Sukhona and Vitehgeda, flows N. W. into the government of Archangel, where it receives the Pinega and the Vaga, and after a course of about 400 m. falls through several months, forming a number of islands, into the White sea, nearly 30 m. below the city of Archangel. It is navigable for its whole length, with an average width of 550 ft., and is the largest stream in northern Europe, traversing a marshy country, and increased by numerous affluents. It forms part of a system of canals completed in 1807, by which a water communication is established between the White, Baltic, Black, and Caspian seas. (For the Southern Dwina, see **DÜNA**.)

**DYAKS**. See **BORNEO**.

**DYCE**. **I. Alexander**, a British scholar, born in Edinburgh, June 30, 1797, died in London, May 15, 1869. He was educated at the high school of Edinburgh and at Exeter college, Oxford, and was several years a curate in Cornwall and Suffolk. In 1827 he removed to London, and for more than 40 years devoted himself to literary and critical studies. His publications were numerous and valuable, showing

not only patient industry and research, but great sagacity and acuteness. His editions of the older English dramatists are highly esteemed. In 1836-'8 he published an edition, with notes, of the works of Richard Bentley (3 vols.). He also contributed to Pickering's "Aldine British Poets" revised texts of Pope, Collins, Beattie, and Akenside, and brief but excellent biographical sketches of these writers. Through his efforts, in conjunction with Collier, Halliwell, Wright, and others, the Percy society was founded in 1840, for the publication of old English ballads and plays. Two editions of Shakespeare, one in 6 vols. (1850-'58), and the other in 9 vols. (1864-'7), contain the finished results of his critical labors and researches. He also wrote "Recollections of the Table Talk of Samuel Rogers." **II. William**, a British painter, cousin of the preceding, born in Aberdeen, Scotland, about 1805, died at Streatham, England, Feb. 14, 1864. He was educated at the university of Aberdeen, and obtained the degree of M. A. in 1822. After studying painting at the academy of Edinburgh, he spent two years (1825-'7) at Rome. On his return he settled in Edinburgh. Having been appointed head master of the school of design, he removed to London in 1838, and subsequently became professor of painting in the university of London. He was elected an associate of the royal academy in 1845, and royal academician in 1848. Having distinguished himself by his frescoes at the Westminster competition in 1844, he was one of the artists chosen to decorate the palace of Westminster and the house of lords, and executed several frescoes at Osborne house. Among his works are "St. Dunstan separating Edwy and Elgiva," "Baptism of Ethelbert" (in the house of lords), "King Joash shooting the Arrow of Deliverance," "Madonna and Child," "Meeting of Jacob and Rachel," "Lear in the Storm," "Christabel," "The Good Shepherd," "Titian preparing to make his Essay in Coloring," "Neptune assigning to Britannia the Empire of the Sea," frescoes in All Saints' church, Margaret street, "St. John leading home his adopted Mother," "The Man of Sorrows," and "George Herbert at Bemerton."

**DYEING**. Among the first records of the human race are frequent intimations of an appreciation of the brilliant hues displayed by natural objects, and means were early found of appropriating them for the adornment of personal apparel. To the fine linen were transferred the brilliant blue, scarlet, and purple hues extracted from vegetable or animal substances, the last named color reserved exclusively for the vestments of kings and high priests. The skins of the ram and the badger used by Moses for the tabernacle were dyed red, and in his time the art of coloring woollen purple was already known. The Tyrians early attained a high perfection in the art, and their king sent to Solomon a man skillful to work "in purple and blue, and in fine



linen and in crimson." Along the coast of Phœnicia they found the two kinds of shellfish called by Pliny the *buccinum* and *purpura*, and from them they extracted a juice which caused their name to be ever associated with the rich purple dye. In such estimation was this held in the time of the Roman emperors, that a pound weight of the cloth which had been twice dipped in it was sold, as Pliny states, for a sum equal to about \$150. But its use being restricted to the emperors, the art of preparing it was at last lost. It was revived in the 17th and 18th centuries in England and France, but better colors and cheaper processes were then in use. The discoverers and early conquerors of the countries of North and South America were astonished by the skill exhibited by the Peruvians and Mexicans in the application of numerous beautiful dyes extracted from forest trees. According to Pliny, the methods of dyeing black, blue, yellow, and green were brought into Greece on the return of the expedition of Alexander the Great from India, where it appears that the art of coloring cotton cloths with rich and permanent dyes had long been known and practised. The Venetians and Genoese in the height of their prosperity, in the time of the crusades, transferred the art to Italy; and Florence in the early part of the 14th century, it is said, contained 200 dyeing establishments. The important dyestuff archil was discovered about the year 1300 by a merchant of Florence. In the 15th century a work upon dyeing was published in Venice, of which subsequent editions were issued down to 1548, containing full details of the processes employed. From this work it appears that the use of indigo was unknown in Europe at the latter date, though in India it was probably an important article in dyeing at the remotest periods. It was afterward introduced from America together with cochineal, logwood, annatto, quercitron, Brazil wood, and other dyes; but its use in England and Saxony, as of logwood also, met with the most determined opposition. The cultivators of the woad then in use for dyeing blue caused decrees to be issued against indigo as a most dangerous product. By the German diet in 1577 it was declared to be "a pernicious, deceitful, eating, and corrosive dye;" and the name was given it of food for the devil. An act of parliament in the reign of Elizabeth forbade its use, and authorized the destruction of it and of logwood wherever found, and this continued in force for nearly a century. About the year 1630 it was discovered that the crimson color obtained from cochineal might be converted into a brilliant scarlet by the application of a salt of tin. The introduction of this metal as an occasional substitute for alum as a mordant is attributed to a dyer named Cornelius Drebbel. The use of pure mordants marks the great improvement of the art in modern times, as also the introduction of a great variety of new dyes ob-

tained from mineral substances. The Flemings during the 17th century carried the skill to which they had attained in this art into Germany, France, and England. After them the French directed particular attention to it, and men of eminence in chemical science, as Du Fay, Hellot, Macquer, and Berthollet, were appointed by the government to investigate and perfect the processes. The method practised in the East of giving to cotton the beautiful and permanent Turkey red dye was made known in their publications, and the art was about the same time introduced into France by some Greek dyers. The business was afterward permanently established at Glasgow by a Frenchman named Papillon.—The art of dyeing consists in the application of colors, principally organic, to animal or vegetable fibre or fabrics, such as silk, woollen, linen, or cotton. Some colors possess the property of uniting with the fibre without the intervention of any other body, the coloring matter being immediately taken up and retained in an insoluble state; such are called substantive colors. Others require the presence of another substance called a mordant, which furnishes a base for the coloring matter to unite with, and which also acts upon the fibre in such a way as to cause the insoluble dye to adhere more closely; these are called adjective colors. The materials also which are to be dyed have different powers of absorbing and retaining coloring matters; wool and silk possessing a greater facility in this respect than cotton or linen. Wool requires much less preparation than cotton to fit it to receive dyes, either with or without the use of mordants, it being only necessary to cleanse it from a fatty substance called the yolk, which is done by scouring it in a weak alkaline solution. The natural varnish which covers the fibre of silk does not prevent it from absorbing the dye, it being only necessary to rinse it in soap lye at a moderate temperature; but to remove the varnish boiling in an alkaline solution is usually practised. The dyeing substance must be applied in a state of solution, that the fibres of the material to be dyed may imbibe it. If, however, it remains in the fibre in a soluble state, it does not constitute a true dye, this term being only applied to a color which is retained as an insoluble precipitate. A color that may be washed out with warm soap suds or a weak alkaline solution is called a fugitive color; and one which will resist the action of these agents is called a fast color. Coloring matter may be fixed within a fabric by three methods: 1. By dissolving the dye in some material which being afterward abstracted will leave it in an insoluble state as regards ordinary solvents, such as soap suds and weak alkaline or acid solutions. If a cloth is stained with a solution of oxide of copper in aqua ammonia, the evaporation of the ammonia will leave the oxide of copper deposited in an insoluble state in and upon the fibre. The deposition in an insoluble condi-

tion of several coal-tar colors from alcoholic solutions is another instance of this mode of dyeing. 2. The coloring matter may be rendered insoluble by subjecting the material stained with it to the action of warm air, a process called ageing. Such is the case with indigo, quercitron, sumach, and fustic. The oxidizing process may also be accomplished by adding some oxidizing material, as when cloth is dyed black with logwood and chromate of potash, the hæmatoxyline of the wood being oxidized and chromic acid reduced to chromic oxide; or when aniline black is produced by the action of chlorate of potash, ferrocyanide of potassium, or chromate of copper upon aniline oil. 3. The coloring matter may be precipitated by the use of a mordant, and this is the most important as well as the most common method. A mordant, strictly speaking, is a solution of some substance which, not being itself a dye, has an affinity for the material to be dyed as well as for the coloring matter of the dyestuff, so that by its means the precipitate will be more firmly fixed upon and within the fibre. Organic coloring matters are generally more firmly fixed than inorganic by the use of mordants. A color is often produced upon a fabric by using two metallic salts whose double decomposition produces an insoluble compound, as for instance the formation of Prussian blue by the action of hydroferrocyanic acid upon a salt of iron, or the production of chromate of lead by using chromate of potash and a soluble lead salt. These latter substances when used in this way are considered by some as not being strictly mordants, but they can hardly be placed in any other category with convenience. The following are the more important mordants: alum; sulphate, acetate, and hyposulphite of alumina; aluminate and stannate of soda; chloride of tin; acetate of iron; fatty substances, as Galipoli oil in Turkey red dyeing; albumen, gluten, and caseine. Tannin is used in some cases as a mordant for madder and aniline colors, and for some metallic salts. Most dyes of organic origin can only be fixed by the use of mordants, but the original color may be much modified by these agents. With alumina compounds madder yields red, pink, and scarlet; with salts of iron, according to the degree of concentration, lilac, purple, and black. Dyed goods are often brightened by passing them through weak acid or alkaline solutions, soap suds, bran bath, or some other dye material. If a piece of cotton stuff is simply stained with a decoction of logwood, the color may be readily washed out with pure water. If, however, it is first dipped in a solution of protosulphate of iron and afterward washed, it will be found stained, a portion of the iron having been converted, either by the action of the air or of the fibre, into insoluble oxide. If the cotton is now dipped into a decoction of logwood, the coloring matter of the latter will combine with the oxide of iron within and upon the fibre,

and form a color which cannot be removed by washing in water. If the cotton is dipped in the sulphate of iron solution and not washed, but passed through an alkaline solution, so that the alkaline base may abstract the acid from the iron salt, a much greater quantity of oxide of iron will be formed within and upon the fibre, and a greater depth of color will be given to it by subsequent immersion in the decoction of logwood. When a solution of sulphate of iron and a decoction of logwood are added to each other, the same insoluble coloring matter will be precipitated in the mixture that was formed by bringing the two solutions together in the fabric. If cotton be now immersed in the mixture, it may be feebly stained, but can hardly be said to be dyed. If, however, a piece of woollen be placed in it, it will become strongly dyed. The precipitates which are formed by the combination of the decoctions of dyestuffs, or the pure coloring matters obtained from them with the bases of certain salts, are called lakes. The salts which are principally used for this purpose are those of aluminum and tin, because, their oxides being colorless, the lakes take the tints of the coloring matters. The lakes obtained with the use of iron salts have a different hue from the original coloring matters, being generally duller. In the salts of aluminum, tin, and iron, the base and acid are not held together by a very strong affinity, and consequently their separation by the attraction of the coloring matter for the base is easily effected; but the acetates are more readily decomposed than the corresponding sulphates, and therefore a mixture of alum with acetate of lead is often used as a mordant. Heat is employed in many cases to facilitate chemical action in dyeing, the solution of salt and coloring matter sometimes remaining together in the cold state without producing a precipitate, where boiling will at once cause it to appear. Sometimes the precipitation is effected by the addition of another substance; thus when a mixture of a solution of alum with certain coloring matters remains clear, a precipitate is formed by the addition of an alkali, which, taking the sulphuric acid from the alum, leaves the alumina to combine with the coloring matter. The principal use of mordants is therefore to form insoluble lakes; but the number of substances that can be used as mordants is much less than of those which may be used for making lakes, on account of the action which some of them have upon the fibre, as well as the influence of the fibre upon their action. The tendency of aluminum, tin, and iron salts to become basic, and of their bases to unite with coloring matters, is what renders them so well adapted to the dyer's art. A cloth to which a mordant has been applied requires before it is dyed to have a certain amount of the mordant fixed within its fibre, and the remainder removed. Fixing the mordant (ageing) is principally accomplished by heat, which promotes the separation of the base

from the acid. It was formerly effected with cotton goods by hanging them up after mordanting in a warm room; but now it is more quickly performed by combining the action of moisture with that of heat. An excessive consumption of coloring matter is avoided by the removal of superfluous mordant; and in the case of printed goods this is necessary to prevent the spreading of the color over the unprinted portions of the surface.—Wool may be dyed in the fleece, in the yarn, or in the cloth. It is usual, for fast colors, to mordant the goods with a solution of alum and cream of tartar; or the latter salt may be used with chloride of tin or with sulphate of iron, the selection depending upon the color which may be desired. For dyeing wool blue the best material is indigo, as it yields the finest and fastest color. This substance is not ready formed in the plants from which it is obtained, but is generated by exposing the juice to the action of the air. It is technically called indigotine, and sometimes oxidized indigo, and is precisely the same substance which exists in the dyed cloth and gives it its color. That it may be deposited in the fibre it is, however, necessary to reduce it to a soluble condition. This is effected by what has been termed deoxidation, but which is more strictly the absorption of hydrogen, as will presently be explained. Soluble indigo, called indigogene, is white, and soluble in alkaline liquids; but upon exposure to the air it parts with the hydrogen which had been absorbed, and again becomes indigotine or blue indigo. It was thought by Chevreul that the juice of the living plant contained indigo white, but this idea cannot be maintained in the light of the fact that white indigo is only soluble in alkaline liquids, whereas the juices of plants are acid. Moreover, the investigations of Schunck show that the organic substance in the living plant which is converted into indigo by fermentation is different from indigo white; he has named it indican. (See INDIGO.) The process of dyeing wool with indigo is accomplished in what are called blue vats, the formation of which differs somewhat in different countries. The German vat, which is very manageable, and may be used for two years by merely replenishing, is composed as follows: To 2,000 gallons of water, heated to 130° F., are added 20 lbs. of crystals of common carbonate of soda, 2½ pecks of bran, and 12 lbs. of ground indigo. The mixture being well stirred, fermentation commences in about 12 hours, the liquid assuming a green color. There are then added 2 lbs. of slaked lime, and the vat is again heated and covered for 12 hours longer, when about the same quantities of soda, bran, and indigo, with some lime, are again added. The vat is ready to be worked in about 48 hours after the commencement. It is usual also to add five or six pints of molasses to promote fermentation. Should this become too active, it is repressed by the addition of more lime; and if it is not

active enough, more bran and molasses are added. The bran and molasses are called reducing agents, because the fermentation which they undergo decomposes a portion of the water, abstracting the oxygen, while the hydrogen is taken up by the insoluble indigotine, or blue indigo,  $C_{16}H_{10}N_2O_2$ , which is thus converted into white indigo, or indigogene,  $C_{16}H_{12}N_2O_2$ , which is soluble in alkaline solutions, but not in pure water. The dyeing is performed by suspending the fabric on frames and moving it about in the vat for about two hours. It is then washed with water and treated with very dilute hydrochloric or sulphuric acid, to remove the alkali. In England blue vats for wool are made with water 500 gallons, indigo 20 lbs., carbonate of potash 30 lbs., bran 9 lbs., madder 9 lbs. The water is heated to just below the boiling point, and the potash, bran, and madder are put in first, and then the indigo, which in all cases should be previously very finely ground. Cold water is added to reduce the temperature to 90° F., which is maintained constantly by a steam pipe. The ingredients are well stirred every 12 hours, and the vat is ready to be worked in 48 hours. It cannot, however, be used for more than a month, and is also more expensive than the German vat, on account of the potash. For dyeing cotton goods, especially if they are heavy, the German vat is used with advantage; but most calicoes are dyed with the cold lime and copperas vat, which is made with 900 gallons of water, 60 lbs. of green copperas, 36 lbs. of ground indigo, and 90 lbs. of slaked lime, stirred every half hour for three or four hours, then left 12 hours to settle and stirred again, when it is ready for dyeing. The reactions are the formation of sulphate of lime and protoxide of iron, which latter body, by reason of its affinity for oxygen, removes this from a portion of the water, leaving the hydrogen to unite with the blue and form white indigo, which is soluble in the excess of lime. For dyeing Saxony blue sulphindigotic acid is employed, a substance formed by the action of concentrated sulphuric acid on indigo. It is made by treating one part of indigo with about five parts of fuming sulphuric acid. The solution is then poured into a vessel containing water, and in this the wool is immersed for 24 hours, when there will be formed upon it insoluble sulphindigotate of alumina. Wool is dyed with Prussian blue by immersing it in a solution of persulphate or pernitrate of iron and then passing it through a solution of ferrocyanide of potassium acidulated with sulphuric acid, by which brilliant, blue, insoluble ferrocyanide of iron, or Prussian blue, is formed. Wool is generally dyed yellow with weld, fustic, or quercitron bark. The yellow coloring matter of weld, luteoline, is extracted by boiling water, to which sometimes caustic lime or alkalis are added to increase the solvent power. Luteoline dissolves with a deep yellow color in caustic alkalis and alkaline carbon-

ates. Its aqueous extract yields beautiful yellow precipitates with alum, chloride of tin, and acetate of lead. Alum and cream of tartar are generally used together as the mordant for this color. The use of weld for wool dyeing has been abandoned in England, but is retained on the continent, and is also largely used there in silk dyeing. It has only about one fourth the tinctorial power of quercitron, which has so greatly superseded it. Fustic or yellow wood is generally considered the most suitable material for working with other colors, and is therefore extensively used. Quercitron bark has, however, more tinctorial power, and is largely used. Either dyestuff is made into a decoction with boiling water, and the goods are mordanted with alum, to which there is sometimes added chloride of tin, which increases the brilliancy of the color. Wool is dyed red with cochineal, with madder, and with coal-tar colors. Madder is used for the more common goods, but for the finer, on account of their superior brilliancy, cochineal colors, and for their peculiar hues the coal-tar colors, are used. The process with madder consists in mordanting the goods with a warm solution of alum and cream of tartar, and afterward immersing them in a madder bath, containing two parts of madder, by weight, to one of the goods, which after dyeing are thoroughly washed. The preparations of madder, such as flowers of madder and garancine, may be used in place of the pulverized root. The dried and ground root, besides containing the two chief coloring principles, alizarine and purpurine, also contains some resinous fawn-colored dyes, which exert an injurious effect when dissolved in the dye; but as they require a higher heat than the two named, it is usual in making a decoction of madder root not to raise it to the boiling point. Flowers of madder and garancine contain scarcely any other coloring matters than alizarine and purpurine. Instead of using the ground root which has undergone a slow fermentation by which the alizarine and purpurine are produced, E. Kopp has invented a process entirely different, and which consists in dissolving the unaltered coloring principle of the living plant, rubian, in sulphurous acid, and subsequently changing it into alizarine and purpurine by the action of sulphuric acid and heat. The process is extensively employed by MM. Schaff and Lauth of Strasburg. (See Madder.) Woollen may be dyed a scarlet or a crimson by the use of cochineal. In dyeing scarlet, cream of tartar, chloride of tin, and cochineal are used together as a mordant, the dyeing liquor being composed of cochineal and tin salt. If a crimson color is desired, it may be communicated by a single process, or the material may be first dyed scarlet. If by one process, a solution of  $2\frac{1}{2}$  oz. of alum and  $1\frac{1}{2}$  of cream of tartar for every pound of stuff is used as a mordant, the dyeing being done with an ounce of cochineal and a smaller quantity of tin salt than is used for

dyeing scarlet. Scarlet may be turned to crimson by using a bath containing an alkaline solution or alum, the latter being generally used. Wool is usually dyed green by first dyeing it blue, mordanting with cream of tartar and alum, and dyeing again with fustic or weld. Sometimes, as in dyeing the woollen fabric for covering billiard tables, alum, cream of tartar, Saxony blue, and fustic are all put together and the cloth immersed in the mixture and boiled two hours, then thoroughly washed and brightened in a second bath of fustic and Saxony blue. Woollen goods may be dyed black with aniline black or with a salt of iron and tannic or gallic acid. To obtain the finest and fastest colors, they are first dyed with madder or indigo. The goods are then mordanted with sulphate of iron and put in a bath made of a decoction of logwood, sumach, or galls. The celebrated Sedan black is produced by first dyeing blue with woad, washing, again dyeing with sumach and logwood, boiling three hours, and then adding a solution of sulphate of iron. Wool, by reason of its great affinity for tar colors, may be dyed with them of almost any hue or shade by simple immersion, subsequent exposure to the air, and washing.—Silk, after treatment in the hot soap bath to remove the varnish, may be dyed without bleaching (sulphuring); but when bright colors are required the goods should be bleached. It may be dyed black by means of logwood with an iron mordant; with logwood and bichromate of potash; with gallic or tannic acid in any form, with iron mordant; or, according to a recent method of Jules Persez, by mordanting with bichromate of potash and sulphate of copper and immersing in a solution of aniline. Silk may be dyed blue with indigo, Prussian blue, or aniline blue. When indigo is used, it is commonly in the form of sulphindigotic acid, or indigo carmine. It is dyed with Prussian blue by using a mordant of nitrate of iron. Napoleon blue is produced by using a mordant of nitrate of iron and chloride of tin, passing through a boiling soap solution, and dyeing with a solution of ferrocyanide of potassium to which has been added hydrochloric acid. The brilliancy is increased by subsequent treatment with solution of ammonia. Silk is dyed with aniline blue by simple immersion for a sufficient time in a solution of the dye in wood spirit or alcohol. Coal-tar colors are now used extensively in dyeing silk, especially the various shades of red, and have largely taken the place of cochineal, although the latter continues to hold its superiority for producing scarlet and crimson. In cochineal dyeing the silk is mordanted with alum, washed, and then immersed in a dye bath made by boiling 2 oz. of white galls for every pound of silk, adding 3 oz. of powdered cochineal, and afterward one fourth of an ounce of cream of tartar, and when it is dissolved, the same quantity of chloride of tin. Silk is more often dyed with fuchsine, coraline, or naphthaline red, the process being the

same as for blue, simple immersion and subsequent washing and exposure. Aniline red, also known as rosaniline, fuchsine, Magenta, and Solferino, is made by combining aniline with various mineral compounds, and also acids, such as chloridé of iron, tetrachloride of tin, nitrate of mercury, nitric acid, and arsenic acid, the last named substance being the one most used. The aniline may be separated from its mineral combinations by the action of alkalies, and the precipitate redissolved in acetic or hydrochloric acid, in one case forming an acetate of rosaniline or fuchsine, and in the other a hydrochlorate. Mauve, or aniline purple, was the first discovered of the aniline dyes, and consists of some salt of mauvine, as the sulphate, according to the process of Perkin, the discoverer, which consisted in oxidizing aniline with bichromate of potash and sulphuric acid. It may be prepared by using other reagents, as by the action of chloride of lime on a solution of aniline in hydrochloric acid. Silk is dyed with it by simple immersion in the alcoholic solution until the desired color is obtained. By the addition of acids a more decided purple may be formed. Since the discovery by Gräbe and Liebermann, in 1869, of the process of artificially producing alizarine from anthracene, this dye, which in chemical composition and behavior is identical with alizarine obtained from madder, has to a considerable extent taken its place, and is one of the principal coal-tar colors. It is used with mordants in a similar manner to that for the preparations of madder. (See ALIZARINE.) Silk is usually dyed yellow, especially on the continent of Europe, with weld, using alum as a mordant. In England, according to the plan of Mr. Bancroft, quercitron bark is frequently substituted, alum being retained as the mordant, to which sometimes a small quantity of tin salt is added. It is cheaper, and is thought to produce a color equal to that given by weld. Silk may be dyed a fast green by mordanting with persulphate of iron, dyeing blue with ferrocyanide of potassium, and afterward adding the yellow by treatment with fustic; but of late aniline green or emeraldine has been used with as much advantage as it previously had been with cotton. It is produced by dyeing with acid hydrochlorate of aniline goods which have been mordanted with chlorate of potash. If they are subsequently passed through a solution of chromate of potash, they are changed to a deep indigo blue, called azurine.—Cotton and linen are more difficult to dye than wool or silk, and require stronger mordants. Cotton may be dyed blue with the cold lime and coperas vat described for dyeing wool, and also by the use of sulphindigotic acid, and linen may be dyed by the same method. Either fabric may be dyed yellow with weld, fustic, quercitron, chrome yellow, or acetate of iron (nankéen). The most brilliant and permanent red which can be imparted to cotton goods, Turkey red, is produced by first saturating them in a

mixture of 100 lbs. of Gallipoli oil, 20 lbs. of pearlsh, and 50 gallons of water. This mixture is sufficient for the preparation of about 2,000 yards of calico. After padding, the pieces are exposed to the air at a temperature of 90° or 100° F. for 24 hours, and the padding and ageing are repeated as many as eight times when a deep color is required. The portion of the oil which has not suffered oxidation is then removed by steeping in an alkaline solution, and the goods are well washed. To a decoction of 30 lbs. of gall nuts there are added 120 lbs. of alum and 10 lbs. of acetate of lead, and the liquor is made up to 120 gallons. The goods are then immersed in it and aged three days, and fixed by passing through ground chalk mixture. They are then washed and dyed in madder, to which are added some sumach and blood. For deep colors the galling, aluming, and dyeing are repeated. The color is then a heavy brown red, which is brightened by soaping, or treatment with dilute nitric acid. The influence of the Gallipoli oil (a crude kind of olive oil) has long been a matter of discussion, but no settled conclusion has been reached in regard to it. It has often been attempted to shorten the process, but without success, except in the clearing and brightening, for which garancine, the product obtained by treating madder with concentrated sulphuric acid, has been used with advantage.—The fullest information in regard to the present state of the art of dyeing is given under the various related titles in Watts's "Dictionary of Chemistry" (6 vols., London, 1870-'72), and Wagner's "Chemical Technology" (New York, 1872). Among special works on the subject are those of C. L. and A. B. Berthollet, "Elements of the Art of Dyeing and Bleaching" (London, 1841); Robert McFarlane, "A practical Treatise on Dyeing and Calico Printing" (New York, 1860); M. Reimann, "Handbook of Anilines" (New York, 1868); Charles O'Neill, "Dictionary of Dyeing and Calico Printing" (Philadelphia, 1869); and James Napier, F. C. S., "Chemistry applied to Dyeing" (Philadelphia, 1869).

**DYER**, a W. county of Tennessee, separated from Missouri by the Mississippi river, and drained by Obion and Forked Deer rivers; area about 400 sq. m.; pop. in 1870, 13,706, of whom 2,893 were colored. The soil is rich, and the surface level and partly occupied by excellent timber tracts. The chief productions in 1870 were 74,090 bushels of wheat, 749,175 of Indian corn, 99,216 lbs. of butter, 412,440 of tobacco, and 4,908 bales of cotton. There were 3,855 horses, 3,531 milch cows, 5,571 other cattle, 8,831 sheep, and 36,448 swine. Capital, Dyersburg.

**DYER, George**, an English author, born in London, March 15, 1755, died there, March 2, 1841. He was educated at Christ's hospital and at Emmanuel college, Cambridge, and was successively a tutor, Baptist minister, parliamentary reporter, and writer. He was a schoolmate and

intimate associate of Charles Lamb. In 1830 he lost his eyesight. He was joint editor of Valpy's combination of the Delphin, Bipont, and Variorum editions of the Latin classics, and published a "History of the University and Colleges of Cambridge" (2 vols., 1814), "The Privileges of the University of Cambridge" (2 vols., 1824), and "Academic Unity" (1827).

**DYER, John**, an English poet, born at Aberglasney, Carmarthenshire, in 1700, died July 24, 1758. He was educated at Westminster, and after a short study of painting he rambled over England as an itinerant artist. In 1727 he published his "Grongar Hill," a poem marked by warmth of sentiment and an elegant simplicity of description. He travelled in Italy to pursue his studies as a painter, but the best result of his observations was his poem entitled "The Ruins of Rome" (1740). On his return he entered holy orders. In 1758 appeared his longer poem of "The Fleece," in which he attempted to treat the subject of wool in a poetical manner, and which is one of the most successful imitations of Virgil's "Georgics." All the poems of Dyer abound in happy and careful pictures of nature, and in appropriate and gentle moral sentiments. They were published collectively in 1761.

**DYER, Mary**, a victim to the persecution which befell the Quakers in the early history of Massachusetts, hanged on Boston common, June 1, 1660. The government of Massachusetts banished Quakers and sentenced to death any one of them who should be guilty of a second visit to the colony. The statute was construed as an invitation instead of a menace by those against whom it was directed. Mary Dyer had departed from their jurisdiction upon the enactment of the law, but soon after returned on purpose to offer up her life. She was arrested and sent to prison, was relieved after being led forth to execution, and was against her will conveyed out of the colony. She speedily returned and suffered as a willing martyr.

**DYMOND, Jonathan**, an English author, born in Exeter in 1796, died May 6, 1828. The son of a linen draper, and himself engaged in the business, he composed his books amid the pressure of other occupations. He was a member of the society of Friends. He published in 1823 an "Inquiry into the Accordance of War with the Principles of Christianity," a work which attracted much attention. His fame rests chiefly on his "Essays on the Principles of Morality," published in 1829, soon after the death of the author.

**DYNAMICS.** See MECHANICS.

**DYNAMITE.** See EXPLOSIVES.

**DYNAMOMETER** (Gr. *δύναμις*, force, and *μέτρον*, a measure), an instrument originally designed to ascertain the strength of men and animals, of the limbs of the body, the fingers, &c. Its application was afterward extended to the determination of the power exerted by machines, or of any portions of them, and the instrument

has hence come into use as a meter of the power of engines. The principle of the earlier contrivances was to weigh the force exerted by the amount of compression or of deflection produced upon an elliptical steel spring; this in the former case being drawn together by the application of the power and of the resistance at the two opposite ends, and in the latter separated by the force and resistance being applied upon the opposite sides of the spring, on the line of the minor axis of the ellipse; an index upon a graduated arc attached to the spring showed the amount of deflection. Another contrivance was a spiral spring enclosed in a tube, the force being applied in the direction of compression. By such means the greatest power exerted by one impulse was indicated; but as in most instances the power is not constant for any determinate time, the index must fluctuate in such a manner that the mean effort it should represent cannot be ascertained. If known, its amount multiplied by the time of continuance of the operation would give as a result the value of the whole power exerted. Instruments have been devised by MM. Poncelet, Morin, and others, which register upon papers, made to pass by a clockwork movement under the index, curved lines from which the whole power is directly calculated from the areas enclosed; the ordinates of the curves representing the power exerted, and the abscissas the length of time, or in some instances the space run over. The apparatus might be fixed to a carriage, the length of the index paper in this instance bearing a certain proportion to the length of the road gone over. A great number of different forms of this instrument have been devised by eminent engineers of France, England, and the United States. One by Watt, improved by Macknought, gives the force exerted by the piston of a steam engine against a spiral spring, a style attached to the piston inscribing a line representing its position during the unrolling of the paper which moves at an even rate against it. In the *Dictionnaire des arts et manufactures* the subject is fully treated in the article *Dynamomètre*, by M. Laboulaye. The descriptions of the various forms of the apparatus are made intelligible by many illustrations. In Appleton's "Dictionary of Mechanics," also, many forms of the apparatus are figured and described; and the following simple contrivance, applicable in some instances, is proposed: A cylinder of some material heavier than water is suspended in this fluid by a rope passing over a pulley. As power is applied to this rope to draw the cylinder out of the water, the increasing weight of this, as more is raised into the air, will at last cause the resistance to equal the force applied, the cylinder being sufficiently large and long. By means of a scale properly arranged, the amount of the power applied may be accurately measured.

**DYRRHACHIUM**, a city of ancient Illyricum, on the coast of the Adriatic, occupying very

nearly the site of the town known in Grecian history as Epidamnus. The latter is said to have been founded by the Corcyreans and by settlers from Corinth, about 627 B. C. Owing to its favorable situation, it soon became a wealthy and populous colony; and the Peloponnesian war arose in great part from a contest between Corinth and Corcyra brought about by appeals to them by the contending factions of Epidamnus. About 310 the Illyrians made themselves masters of the place, and not long afterward the inhabitants put themselves under the protection of the Romans, by whom its name was changed to Dyrrhachium. At a later period it was prominent in the contest between Cæsar and Pompey, and in 1081-'2 became memorable for its siege and capture by Robert Guiscard, who defeated there the Greeks under their emperor Alexis. (See DURAZZO.)

**DYSART**, or **Desart**, a parliamentary borough and seaport town of Fifeshire, Scotland, 12 m. N. N. E. of Edinburgh, on the N. side of the frith of Forth; pop. in 1871, 8,920. The town is very old, and in former times was a place of much importance. It carries on ship building, flax spinning, and manufactures of damasks and ticks. There are coal and iron mines in the vicinity.

**DYSENTERY** (Gr. *δυσ*, ill, and *έντερον*, intestine), an inflammation of the large intestine, producing frequent straining efforts at stool, attended by small and painful mucous and bloody discharges. Dysentery is more common in hot climates than in temperate ones; in summer and autumn than in winter and spring. It is subject to epidemic influences, being in some seasons frequent and fatal over an extensive region, and then almost disappearing for years. It is more common and severe in malarious districts. It sometimes breaks out and is excessively fatal in public institutions where the inmates have been subject to a vitiated atmosphere and an improper and innutritious diet; and it has often proved very destructive to armies. It is commonly attributed to the use of irritating and indigestible food, and to cold, particularly after the body has been debilitated by a prolonged exposure to heat. The milder cases are attended by little or no fever; but when the disease is severe fever is always present, and may precede though it more commonly follows the local manifestations. There is often much pain and soreness in the lower part of the abdomen or extending along the track of the colon, and frequent calls to stool, attended with painful and often violent straining; the stools consist chiefly of mucus more or less tinged with blood, and sometimes mixed with membranous shreds, or they may consist of blood almost pure, or resemble the washings of flesh; their odor is not feculent, but faint and peculiar, and sometimes fetid; occasionally the neck of the bladder sympathizes with the neighboring bowel, and there is difficulty in passing urine.

While mild cases of dysentery are attended with no danger, when severe the disease is always serious and often fatal; or it may become chronic, and slowly break down the constitution. When death occurs, *post mortem* examination reveals the existence of inflammation and ulceration in the large intestine. The ulcers are often large, irregular in shape, laying bare the muscular and sometimes the peritoneal coat; between them the mucous membrane is thickened, often lined with false membrane, sometimes appearing as if struck with gangrene.—When the pain and tenderness are very considerable, the treatment may be commenced by the application of leeches over the track of the inflamed bowel; if any constipation has previously existed, a dose of castor oil, to which a few drops of laudanum have been added, may be given; opiates and astringents may be afterward administered. From the fact that the rectum is the part of the intestinal canal most affected, opiates in the form of suppositories or enemata are found particularly useful. Calomel has been highly recommended in the treatment of the dysentery of tropical climates, but in temperate regions it is rarely necessary to resort to it. The patient should be confined to his bed, and the diet should be of the mildest and most unirritating character. When the dysentery becomes chronic, the tenesmus subsides, the stools are more copious and loose, and contain pus; the complaint is apt to be tedious and intractable, and when recovery takes place, the digestive organs remain for a long time feeble and irritable. A strictly regulated diet, with the use of opium, combined with a small dose of sulphate of copper or nitrate of silver, are the means commonly had recourse to in its treatment.

**DYSPEPSIA** (Gr. *δυσ*, ill, and *πέψις*, digestion), or **Indigestion**, a designation under which are commonly grouped all those functional disorders of the stomach which are independent of organic disease, and are not symptomatic of disease of other parts of the economy. Its characteristic symptoms, as given by Cullen, are "want of appetite, nausea, vomiting, flatulence, eructations, and pain; more or fewer of these symptoms concurring, together sometimes with constipation." Many circumstances must concur to render digestion easy and perfect. The mind should be free from any harassing care or anxiety; otherwise not only the appetite is impaired, but the food is digested with difficulty. The food should be thoroughly masticated and insalivated. After recovery from wasting diseases, a larger quantity of food is required and will be digested than at ordinary times. It should be suited to the digestive capacity of the stomach; if the quantity be too large or the quality too rich, a sense of fullness and weight in the region of the stomach, nausea, heartburn, and eructation of acid and gaseous matters follow; with these symptoms the tongue becomes furred, there is some feverish-

ness, and there is more or less headache; if vomiting occurs, and the ejecta contain bile, the sufferer in ordinary phrase is said to have had a bilious attack. The food should be taken at proper intervals, which are not always the same for all persons; before a second meal is taken, the previous one should be completely digested, and the stomach should have a period of repose. The food ought not only to be of a character which will permit its easy digestion by the stomach and small intestines, but it should also afford a residuum bulky and stimulating enough to maintain a regular action of the bowels. When constipation is induced by neglect, indolent habits, or too concentrated a diet, the stomach is apt to suffer, and dyspeptic symptoms follow. To all these causes of dyspepsia must be added the abuse of fermented and distilled liquors.—When dyspepsia has been induced by any one of the above mentioned causes, its cure is to be sought in the removal of the cause; but this alone will often be found tedious or inefficient. In one class of cases a certain degree of inflammation of the gastric mucous membrane seems to be produced. The presence of food excites pain, which continues so long as the food remains in the stomach; carminatives or stimulants, so far

from affording relief, aggravate the distress. In some cases the diet must be of the blandest and most unstimulating kind, and the amount of food rigidly limited. Restricting the patient to milk, diluted with an equal part of lime water, is sometimes attended by great benefit, and farinaceous articles are preferable to meat. In another and the larger class of cases, neither inflammation nor irritation is present, but the powers of the stomach seem enfeebled; here stimulants relieve the distress, and cause at least a temporary improvement. In such cases a meat diet agrees better than an exclusively farinaceous one, and the patient is benefited by bitter tonics, as colombo, gentian, or quassia. Certain remedies are adapted to the relief of particular symptoms; acidity is relieved by the use of alkalies and the alkaline earths; pain, by bismuth and hydrocyanic acid; flatulence, by carminatives; and constipation, when it cannot be obviated by diet and attention, may call forth the use of some of the purgative mineral waters, or of small doses of aloes in combination with nuxvomica. It is in these cases that travel, combining relaxation with mental excitement and exercise, is particularly serviceable.

**DZIGGETAI.** See Ass.

## E

**E**, THE fifth letter and second vowel of the Latin alphabet, and of those derived from it. It is both short and long, and in the Greek alphabet has two corresponding forms, ε ψιλόν (slender E), the fifth letter, and ἦρα (long E), the seventh letter (but counting eight if the stigma be included). The short and long O, ο μικρόν and ὦ μέγα, are analogous to them. Simonides is said to have formed the Η (ἦρα) by doubling the E (ε ψιλόν), thus ΕΗ, the epsilon having before been both short and long. The Η, however, was made by the Latins an aspirate, and was employed to represent the rough breathing, and the aspirate sound in Θ, Φ, and Χ, as *Homerus, Thales, Phylon, Charon*. The prototypes of the aspirated Greek letters in question are the Phœnician and Hebrew *He* and *Chet*. Indicating the most fleeting sound of the human voice, a mere breathing in many cases, the letter E is the basis of the vowel system and the most protean of all the vowels, as regards its shades of sound, its convertibility, the modes in which it is indicated in writing, and the uses that are made of it in various graphic systems. But few of its peculiarities can here be pointed out. In English it has five sounds, called long, short, open, obtuse, and obscure, respectively as in *mete, met, there, her, and brier*. The long English sound corresponds to the French and German I, while the French nasal E in *em* and *en* sounds like the English *a* in *mart*, and that in *bien* like the *a*

in *man*; and the sound of the French sharp E is represented in English by *a, ai, ay, or ey*, as in *made, maid, say, and they*. In Hebrew it has two sounds; the open is noted by *Tzere* (break), or two horizontal dots under the consonant; the close by *Segol* (grape) or three dots, and two kinds of *Sheva* (emptiness), or two vertical dots, the one movable (half mute), the other quiescent (mute). The long E is written AI in Mæso-Gothic. In Greek the long and short E (ε and η) are both either open or close, but the latter is pronounced as I in Neo-Hellenic, Coptic, and Old Slavic. It is often a euphonic means for facilitating the utterance of words, as in *establish, établir, establecer, épice, espritu, esprit, escrîvir, écrire, estado, état, estrella, étoile, Estéean, and Étienne*. It is prefixed for other reasons in *εκενος, ecquis*, and many other words. E frequently occurs instead of I in ancient Roman memorials, as on the *columna rostrata* of Duilius, on the tomb of the Scipios, and in manuscripts; thus, *sebe, quase, maeester, fuet, for sibi, quasi, magister, fuit*. In the Slavic it occupies, as *jest*, the sixth place of the Bukvitsa as well as of the Cyrillic scheme, and has two softening forms as finals (*-er, -eri*) toward the close of the alphabet.—Barrois asserts that E signifies one, since it is the initial of the Greek *εἰς*. As an abbreviation, E stands for Ennius, *eques Romanus, egregius, emeritus, ergo, editio, east, electricity, and excellence*. The letters *d. e.*



r. stand for *de ed re*; g. e. d. for *quod erat demonstrandum*; e. g. and e. c. for *exempli gratia* and *exempli causa*. In syllogisms, A = *asserit*, E = *negat*. On French coins it designates Tours; on those of Austria, Carlsburg in Transylvania; on those of Prussia, Königsberg. In Greek, E has the value of 5, and with a mark below it, of 5,000. According to Baronius, it represented the number 250 in the period of the decline of classic literature. It denotes the third great interval in modern musical nomenclature, or the fifth string in the chromatic scale, and is called *mi* in vocal music.

**EACHARD, John**, an English divine, born in Suffolk in 1636, died July 7, 1697. He was a fellow of Cambridge, in 1675 succeeded Dr. Lightfoot as master of Catharine hall, and early became known by his satires against the clergymen of his time. He wrote upon "The Grounds and Occasions of the Contempt of the Clergy and Religion," which he attributed to the insufficient salaries of clergymen, and the consequent necessity for them to eke out a living by unbecoming means. The work passed rapidly through six editions, and drew down upon its author abundant criticisms. He published two dialogues upon Hobbes's "State of Nature," in which he humorously attacked the ideas of that philosopher. An edition of his works was published in 1714, in 3 vols. 12mo.

**EADMER, or Edmer**, an English monk and historian, died in 1124. He was chosen in 1120 bishop of St. Andrews in Scotland, but the Scottish king refusing to allow his consecration by the archbishop of Canterbury, and thus to admit the primacy of that see, he either declined the bishopric or abdicated it after a short possession, and died as a monk of Canterbury. Besides a life of his friend St. Anselm, contained in most of his editions of Anselm's works, he wrote the lives of Wilfred, Dunstan, and other English saints; but his most valuable work is the "History of his own Times," an account of the principal events in England and in the English church from 1066 to 1122 (best ed. by Selden, 1623).

**EAGLE**, a bird of prey, of the order *raptores*, family *falconidae*, and subfamily *aquilinae*. The eagles have a strong bill, elevated at the culmen, straight at the base, and much arched to the tip, which is hooked and sharp; the sides are compressed, and the lateral margins festooned; the nostrils are in the cere, large; the wings are long and acute, the third, fourth, and fifth quills usually the longest; the tail is long, ample, mostly rounded at the end; the tarsi are long, either clothed with feathers to the base of the toes as in the golden eagle, or naked and covered with scales as in the bald eagle; the toes are long, strong, armed with large, curved, and sharp claws. In the type genus *aquila* (Möhr.) belongs the golden eagle of Europe and America (*A. chrysaetos*, Linn.). The length is about 3 ft. 2 in., the extent of wings 7 ft., the bill along the back 2½ in., the tarsus 4½ in., and the middle toe and

claw the same; the bill is very robust, angular above; the head is moderate, the neck short, and the body full; the tarsi are feathered to the toes, and the feet are very stout; the middle toe has a membrane at the base connecting it with the others. These are the dimensions of an adult female, the male being considerably smaller, in conformity with the rule that in birds of prey the females are larger than the males. The plumage is compact, imbricated, and glossy; the feathers of the neck and head are narrow and pointed, and may be erected like a short crest; the tail consists of 12 broad feathers. In the adult the bill is black at the tip, bluish gray at the base, the cere and margins yellow; iris chestnut; toes bright yellow, claws black; general color of the plumage dark brown, glossed with purple; the hind head and neck light brownish yellow, the feathers with dark shafts; the wing coverts light brown; primaries brownish black; tail round-



Golden Eagle (*Aquila chrysaetos*).

ed, dark brown, lighter at the base, irregularly marked with whitish; lower tail coverts, feathers of legs and tarsi, yellowish brown. The immature bird is of a deep brown, with the tail white at the base for three quarters of its length, and dark at the end; this is the ring-tailed eagle of Wilson and others; the adult, from its majestic appearance, is called in Europe the royal eagle; the American species is considered distinct by some, and is called *A. canadensis* (Linn.). The golden eagle is rarely seen in the eastern portion of the United States, though specimens have been obtained in all the northern states; the species is most common in the northwest, on the upper Mississippi, and in the mountainous regions; it is also found in the cold and mountainous districts of northern Europe and Asia. The flight is powerful, though less rapid than that of the bald eagle, being continued for hours in majestic circles at a great elevation, and without apparent exertion; its prey is not seized on

the wing, but is pounced upon on the ground from a great height with rarely failing precision. Its food consists of young fawns, raccoons, hares, wild turkeys, and other birds and animals of similar size, and, when hard pressed by hunger, of carrion; capable of going several days without food, it gorges itself when opportunity offers. Its strength is great, its weight about 12 lbs.; it is able to withstand extreme cold, and pursues its prey in the most violent storms. The voice is harsh and screaming, and very loud at the breeding season. The plumage does not attain its full beauty until the fourth year; the American Indians are fond of using the tail feathers as ornaments for their persons, pipes, and weapons. The nest is large, consists of a rude collection of sticks, and is placed on some inaccessible cliff; the eggs are generally two, of a dull white, with brownish shades,  $3\frac{1}{2}$  in. long and  $2\frac{1}{2}$  in diameter at the widest part; they are laid in February or March; the young, when able to provide for themselves, are driven from the eyry. This bird is long-lived, individuals, it is said, having been kept in captivity for more than a century. In proportion to their size, the eagles are less courageous and less powerful than the falcons. The noble nature of the eagle, like that of the lion, is mostly a creation of the imagination, founded on external characters which have no corresponding internal qualities; he attacks where he is sure of victory, gorges himself like a glutton, patiently bears forced abstinence from food, and at last soils his beak with carrion; the king bird and the shrike are far his superiors in bravery, and all the qualities which have been specially assumed for him can be found in great perfection in many common birds. The eagle is monogamous, and the mated pair are generally not far from each other; the same nest is used for many years. The scent of the eagle is feeble, but his sight is exceedingly keen. Like the condor, the eagle has been accused of carrying off little children to its nest, but such instances in both birds must be very rare, though they may have occurred. Another species of this genus is the spotted or rough-footed eagle (*A. navia*, Gmel.), smaller than the golden, of a brownish color, with black white-tipped tail and wings yellow spotted; it is found in the mountains of central and southern Europe and northern Africa, and preys upon the smaller animals.—In the genus *haliaëtus* (Sav.) belong the fishing or sea eagles, the best known and largest of which is the bald or white-headed eagle (*H. leucocephalus*, Linn.). The bill is  $2\frac{1}{2}$  in. long, very robust, convex above; the head is large, and flat above; neck short and thick; body large, wings long, and tail rounded; the tarsus only 3 in. long, bare for its lower two thirds, and covered with large scales; the feet are short and robust, and the toes are free, rough, and tuberculous beneath, with very sharp curved claws. The plumage is compact and imbricated; the feathers of the head,

neck, and breast are narrow and pointed, and of the other parts broad and rounded; there is a bare space between the bill and eye with a few bristly feathers; the eyebrows are bare and very prominent. In the adult the bill, cere, iris, and feet are yellow, the first three being often almost white; the general color of the plumage is chocolate-brown, the feathers with paler margins; the head, greater part of neck, tail and its coverts, white; the quills are brownish black, with lighter shafts. The length is about 3 ft., and the extent of wings 7 ft.; the female is somewhat larger. In the young bird the bill is black above, bluish gray at the end of the lower mandible; the feathers, which are white in the adult, are dark brown like the rest of the plumage, margined with lighter; the head and tail become white between the third and tenth year, according to circumstances. It is very generally distributed over North America. Its usual food



Bald Eagle (*Haliaëtus leucocephalus*).

is fish, but it eats the flesh of animals when it can get it, and often seizes small quadrupeds and birds of inferior flight, and when pressed by hunger will feed on decaying carcasses. When the fish hawk follows the shoals of fish in the rivers in spring, the eagle sits watching from the top of a tall tree; as soon as the former rises with a fish, and bends his course for the shore to devour it, the latter mounts above him, and forces him to give up his prey; the eagle closes his wings, drops down with great quickness, and seizes the fish before it reaches the water. The flight of this bird is very majestic, accomplished by easy flappings; it sails along with extended wings, and, according to Audubon, can ascend until it disappears from view, without any apparent motion of the wings or tail; and from the greatest heights it descends with a rapidity which cannot be followed by the eye. All authors are agreed as to the cowardice of the eagle when it is suddenly surprised or meets with unexpected re-

sistance; a game cock put into a cage with a full-grown male at once attacked the eagle and beat him in the most approved manner, and even the common cock has fairly put this cowardly bird to flight. The females are somewhat larger, braver, and fiercer than the males. Like the golden eagles, these birds live to a great age. They are generally seen in pairs, and the union appears to last for life. Along the southern Mississippi incubation commences in January; the nest is placed on the top of a tall tree, and not on cliffs like the golden eagle's; it is rudely made of sticks, turf, weeds, and moss, 5 or 6 ft. in diameter, used year after year, and added to annually. The eggs are usually two, of a dull white color. The attachment of the old birds to their young is great. The weight of the adult male is from 6 to 8 lbs., that of the female from 8 to 12. The flesh of the young is said to be palatable, having the taste of veal. Franklin, as quoted by Audubon, laments that this bird should have been selected as the emblem of the United States, on account of its cowardice, tyranny, and general ill condition. As observed in confinement, the female not only attacks and abuses the male, but stretches her wings to the utmost extent, attempting to cover with them every piece of food placed in the cage. The name of bald eagle is really a misnomer, as the head is as thickly feathered as in any species; the proper name is white-headed eagle.—The bird of Washington (*H. Washingtonii*, Aud.) was first described by Audubon ("Ornithological Biography," vol. i., p. 58), and seems not to have been seen by any other ornithologist; he first saw it on the upper Mississippi in February, 1814; a few years after he met with a pair near the Ohio river in Kentucky, which had built their nest on a range of high cliffs; two years after the discovery of the nest he killed a male which was the subject of his description; after this he saw two other pairs near the Ohio river. The flight of this is said to be different from that of the white-headed eagle, the former encircling a greater space, sailing nearer the surface of the earth, and darting spirally upon its prey. The bill was bluish black, with pale edges; the iris chestnut-brown; upper part of the head, hind neck, back, scapulars, rump, tail coverts, and posterior tibial feathers, blackish brown, with a coppery gloss; the throat, fore neck, breast, and abdomen light brownish yellow, each feather blackish brown in the centre; wing coverts light grayish brown, those next the body approaching the color of the back; primaries and tail dark brown; anterior tibial feathers grayish brown. The length is given at 3 ft. 7 in., extent of wings 10 ft. 2 in., bill 3½ in., tarsus 4½ in., and the weight 14½ lbs.; this was a male, and of course the female would have been considerably larger. Though this bird is generally admitted as a species on the authority of Audubon, many ornithologists do not regard it as such; and from Audubon's own testimony

there seems sufficient ground for doubting the validity of the species.—The white-tailed or cinereous sea eagle of Enrope (*H. albicilla*, Linn.), the young of which Audubon thinks bears the greatest resemblance to his bird of Washington, has at this age a blackish bill; head and hind neck dark brown, with white markings, disappearing with age; fore neck and breast brown, with brownish white marks; general color of the plumage light brown, with a dark streak on the middle of each feather. In the old bird the bill becomes yellow, the general plumage grayish brown, palest on the head and neck, and the tail white; the length is 3 ft., and the extent of wings 6 ft. 9 in. This species, called also osprey, ossifrage, and pygargus, is distributed over the northern portions of the old world; it feeds principally on fish, like our white-headed eagle, forcing the fish hawk to provide for it. It prefers cold climates, and the vicinity of the sea, though it visits the interior rivers and lakes; when un-



Cinereous Sea Eagle (*Haliaeetus albicilla*).

able to obtain fish, it feeds upon sea birds, young seals, and any small animals which it can surprise. Its flight is neither so elevated nor so rapid as that of the previously described species. The nest is placed on cliffs near the sea, and the eggs are two, of a dirty white color; incubation takes place in April.—The northern sea eagle (*H. pelagicus*, Pallas) is the largest of the family, and inhabits the islands of Alaska and northeastern Asia. The total length of the female is 3¾ ft.; the wings are shorter than usual, and the tail is wedge-shaped. In the adult the bill and the legs are yellow; the general plumage brownish black, with a large frontal space, greater wing coverts, abdomen, and tail, white. In the young the tail is white, with brownish black marks, the quills black, the secondaries and tertiaries white at their bases; other parts dull brownish black. It is a fishing eagle, though it occasionally captures birds and quadrupeds. According to Pallas, it breeds in northeastern Asia.—There are several genera of smaller

eagles, as the crested eagles (*spizaetus*, Vieill.). The black-tufted eagle (*S. ornatus*, Daud.) is as large as a raven, black, with a long tuft hanging from the occiput, and the edge of the wings and bands under the tail whitish; the crest is mixed with white; the thighs and tarsal feathers banded with black and white; tarsus feathered to the toes; it inhabits South America.



Reptile Eagle (*Morphnus urubitinga*).

Other species are found in Africa and the Indian archipelago, where they live in jungles and woods, pouncing on pheasants, hares, and similar animals passing underneath; they also seize prey on the wing. The reptile eagles (*morphnus*, Cuv.) are peculiar to South America; they live in the forests, feeding on reptiles, small animals, and birds. A well known



Brazilian Eagle, or Caracara (*Polyborus tharus*).

species is the *M. urubitinga* (Gmel.); this is black, without a crest, rump and lower part of the tail white; the long tarsi are bare of feathers. The harpy eagles (genus *thrasaetus*, Gray, or *harpia*, Vieill.) are peculiar to South America; they will be described in the article HARPY. The genus *pandion* (Sav.) will be described under FISH HAWK, the common name

of the best known species.—The caracara, or Brazilian eagle, does not belong to the *aquilinae*, but to the *polyborinae*, a subfamily coming nearest to the vultures; this bird (*polyborus tharus*, Molina) is of various shades of brown, with streaks and mottlings of brownish black; wings barred with white, and the tail coverts dull white barred with dusky; tail grayish white, with 16 narrow bars and a terminal band of blackish brown; the length is about 2 ft. and the extent of wings 4 ft., the bill  $2\frac{1}{4}$  in. It is found from Florida to Brazil, and it feeds on carcasses, small reptiles, and birds; it has the habits of the vultures, with the additional power of carrying prey in its talons; it walks like the turkey buzzard; its flight is rapid and graceful.—The eagle, in mythology, is the sacred bird of the Hindoo Vishnu and of the Greek Zeus. In the Roman ceremony of apotheosis an eagle ascended from the burning catafalque, and was believed to bear the soul of the deceased to Olympus. In the Scandinavian mythology, it is the bird of wisdom, and sits in the boughs of the tree *ygdrasil*.—The Etruscans were the first who adopted the eagle as the symbol of royal power, and bore its image as a standard at the head of their armies. From the time of Marius it was the principal emblem of the Roman republic, and the only standard of the legions. It was represented with outspread wings, and was usually of silver till the reign of Hadrian, who made it of gold. The double-headed eagle was in use among the Byzantine emperors, to indicate, it is said, their claim to the empire both of the East and the West; it was adopted in the 14th century by the German emperors, and afterward appeared on the arms of Russia. The arms of Prussia are distinguished by the black eagle, and those of Poland bore the white. The white-headed eagle is the emblematic device of the United States of America, is the badge of the order of the Cincinnati, and is figured on coins. Napoleon adopted the eagle for the emblem of imperial France; it was not, however, represented in heraldic style, but in its natural form, with the thunderbolts of Jupiter. It was disused under the Bourbons, but was restored by a decree of Louis Napoleon (Jan. 1, 1852).

**EAGLE**, a gold coin of the United States, of the value of \$10, first coined in 1795, as provided by the act of congress of April 2, 1792, of the fineness of 22 carats ( $916\frac{2}{3}$  thousandths), and weighing 270 grains, thus containing  $247\frac{1}{2}$  grains of pure gold. The silver dollar contained at the same time  $371\frac{1}{2}$  grains pure silver, the ratio of valuation of silver to gold being as 15 to 1. An ounce of pure gold being worth more than 15 of silver in Europe, our gold coins continued to be exported until the act of June 28, 1834, substituted the ratio of 16 to 1 by reducing the fineness of the eagle to  $899\frac{2}{10}$  thousandths, and its weight to 258 grains, being 232 grains pure gold. By the act of Jan. 18, 1837, the fineness of the eagle, as of all the other gold and silver coins, was

raised to 900 thousandths, its weight remaining as before, 258 grains, of which  $232\frac{2}{10}$  were pure gold; and at these rates it continues to be coined. There are also a half eagle, first coined in 1795, a quarter eagle, first coined in 1796, and a double eagle, first coined in 1849. These coins are a legal tender for all sums. The number of coins of each kind produced at the mint and branches from their organization to June 30, 1873, is as follows:

Double eagles.....	32,336,404	Half eagles.....	13,959,842
Eagles.....	5,553,249	Quarter eagles.....	10,417,561

The total number of pieces is 62,267,056, valued at \$798,103,682 50. (See Coins.)

**EAGLE WOOD**, a fragrant wood containing an abundance of resin and an essential oil, highly esteemed for its perfume by Asiatics, who burn it as incense. The tree from which it is obtained is a native of the East Indies, and belongs to the genus *aquilaria*. There are three varieties, *A. Malaccensis* or *ovata*, indigenous to Malacca and Siam, where it is called *garos*, and to which the name eagle wood is more generally applied; *A. gallochum*, a large tree with alternate lance-shaped stalked leaves, a native of Sillet, where it is called *ugoor*, supposed to be the *calambac* or *agallochum* of the ancients; and *A. secundaria*, a tree whose wood is white and inodorous in a healthy state, but when attacked by a disease to which it is subject becomes colored and gives out a powerful scent. The Cochin Chinese are said to make their paper from its bark. Eagle wood is largely used in India and Siam, but the greater part of it is exported to China. According to French authorities, it was burned as a perfume in the imperial palace in the time of Napoleon I. In India it is used also as a cure for the gout, and it is sometimes prescribed in Europe in rheumatic affections. Its Malayan name is *agila*, whence the wood was called by the Portuguese *pão d'agila*, which became corrupted into *pão d'aguila*, and finally *pão d'aguila* or eagle wood.

**EAR**, the organ of hearing. Anatomists divide it into the external, the middle, and the internal ear. The first consists of the visible external organ, a cartilaginous and fleshy structure, of the form best adapted to collect the atmospheric vibrations, and the meatus or tubular opening leading to the tympanum. The tympanum is a firm fibrous membrane stretched across this opening, whose office, as its name implies, is to communicate vibrations like the head of a drum. The middle ear is a cavity about the form and size of a kidney bean; from its lower point a tubular canal descends to the side of the pharynx, where it terminates in a trumpet-like expansion; this canal is called the Eustachian tube. Across the middle ear is stretched a chain of three small bones, connected with each other by cartilage and tendon. These are the *malleus* or mallet, the *incus* or anvil, and the *stapes* or stirrup, each named from some fancied resemblance. The

office of this chain, which is attached to the tympanum at one end, and to the membrane covering the *foramen ovale* at the other, is to transmit the vibrations of the air; to aid in this, they are controlled by three minute muscles, which serve to regulate the tension of the membrane of the tympanum, and the pressure of the stapes against the membrane of the foramen ovale. The internal ear, also called the labyrinth, to which the external and middle ear are but the anterooms, consists of the vestibule, the three semicircular canals, and the cochlea. The vestibule is an irregular cavity shut out from the middle ear by the membrane covering the foramen ovale, and communicating with the semicircular canals by five openings, two of these canals being joined at one end. The cochlea, as its name

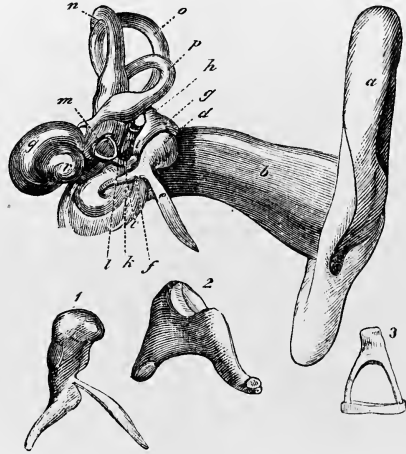

The Parts of the Auditory Apparatus.—*a*, external ear; *b*, auditory meatus; *c*, membrane of the tympanum; *d*, head of the malleus; *e*, bony process, and *f*, handle of the malleus; *g*, incus; *h, i*, short and long processes of the incus; *k, l*, articulation of incus and stapes; *m*, stapes; *n, o, p*, semicircular canals; *q*, cochlea; *r*, apex of the cochlea; 1, 2, 3, malleus, incus, and stapes, separated from each other and highly magnified.

implies, is a bony structure resembling in form a snail shell; internally it is divided by a lamina, bony, ligamentous, and muscular, into two cavities called the *scala vestibuli* and the *scala tympani*, which communicate at the top of the cochlea, in a curved channel called the *helicotrema*. The *modiolus*, or bony axis of the cochlea, has numerous orifices, through which pass the filaments of the auditory nerve. The whole internal ear is lined with a delicate serous membrane, containing a fluid called perilymph. Within the vestibule and the semicircular canals, we find the membranous labyrinth; in the vestibule it consists of two membranous sacs, one called the *utricle* and the other the *sacculus*, communicating with each other and extending in slender tubes through the semicircular canals, of which they only occupy about one third; in the vestibule and in the ampullæ of the semicircular canals these

sacs receive the nervous filaments, and are thus connected with the serous membrane lining the labyrinth, but everywhere else they are free, and separated from it by the perilymph, while their cavities contain a similar fluid called endolymph. In the vestibular portion is found a crystalline powder, proved by chemical experiment to be carbonate of lime, and denominated *otolithes*; the office of this is supposed to be to communicate the vibrations to the nervous surfaces. The filaments of the auditory nerve terminate by loops, or minute points, in the sacculus, the utriculus, the ampullæ of the membranous semicircular canals, and the membranous lamina which divides the cochlea. In the process of hearing, the vibrations of the atmosphere, caused, we will say, by touching one of the keys of a piano, pass toward the external ear, where they are collected and concentrated by its peculiar form and structure; thus concentrated, they pass along the canal to the tympanum, where they produce a vibration; this vibration is communicated by the chain of bones to the membrane covering the foramen ovale, by which it is passed to the fluid contents of the vestibule and to the sacs, and thus reaches the nervous surface, which is expanded over the whole labyrinth, and produces the sensation of sound. The internal and middle ear are situated wholly within the temporal bone, which is here much thicker and harder than elsewhere, in order to protect the delicate and complicated structure from injury.—In the article DEAF AND DUMB we have spoken in general terms of the causes which induce deafness; but we may say here that while congenital deafness is usually the result of deficiency or malformation of some portion of the organ, thus preventing the transmission of the vibration or sound wave, accidental deafness usually arises from mucous secretions, the result of inflammation, clogging or thickening the membranes of the middle ear, or ulceration attacking the little bones and causing their discharge; inflammation of the serous membrane of the labyrinth; or paralysis of the auditory nerve. As may be supposed, the cure of complete deafness is exceedingly rare.—The sense of hearing, like most of the senses, is capable of a much higher cultivation than is generally given to it. The blind, to whom touch and hearing make up in part for the loss of vision, acquire remarkable powers of hearing. They will hear a footstep or the opening of a door at a distance at which ordinary persons cannot distinguish a sound. In some brain affections there is more or less morbid sensitiveness of hearing; and in that condition of the nervous system brought on by long continued and intense excitement, and which often terminates in insanity, the same phenomenon is observed.—The form of the external ear varies materially in different races of men, and still more in the animal tribes. In the Caucasian race it is of moderate size, well formed, and neither

very prominent nor pressed closely to the head. In the Malay and Mongolian it is large, ill-proportioned, the lobe naturally long, and the whole ear standing out prominently; in the Indian race the conformation is similar to the Mongolian, though less prominent; in the negro the ear is flat, broad, and adheres so closely to the head as to give the idea of having been fastened there by a bandage. Of the inferior animals, the mammalia only have an external ear; in birds it is merely a small orifice; in fishes, when it exists, it is covered by the skin, as it is also in reptiles. The variety in its form in mammals extends even to different varieties of the same animal. The drooping ear of the King Charles and other spaniels contrasts forcibly with the erect prominent ear of the foxhound and the Esquimaux dog; and both differ greatly from the short open ear of the bulldog. The horse has a sensitive and well formed ear, though of small size; while the ass, with no better powers of hearing, is supplied with long aurial appendages which seem most adapted for fans. The elephant has a small ear as compared with his great size, though the flap of skin which protects it is of considerable dimensions. The carnivora generally have small but very quick ears, and they usually possess erectile power, which enables them to throw them into shapes in which they will most readily catch the sound wave. The mole, though his ear is hardly discernible in the fine fur which covers it, is yet very quick of hearing. Of all the mammals, the bat tribe possess the largest ears in proportion to the size of their bodies, the *phyllostomus* and the *megadenus* in particular being provided with these appendages so large as to form nearly one third of the superficial extent of their bodies. Among savage and half-civilized tribes the idea prevails that the lengthening of the lobe of the ear by heavy ornaments, and the enlargement of the perforations made for attaching them, both add greatly to the beauty of the wearer. In the Burmese statues of Gaudama he is represented in a sitting posture, and the lobes of his ears extend to the level of his lap. Among the African tribes the perforation in the ear is enlarged so that a stick an inch or more in diameter may be thrust through it, and some of them use the ear instead of a pocket to carry small articles.

**EARL**, the most ancient title of nobility used in Great Britain. Under the early Saxon kings the powerful nobles to whose charge shires or territories had been committed were called *ealdormen*, literally elder men (whence the modern alderman), a term equivalent to the Latin *senior* or *senator*, and given in Latin documents as *princeps*, *dux*, or *comes*. The Danes subsequently applied the term *eorle*, which signified originally a man of noble birth, as opposed to the *ceorl* or churl, to the same men who had borne the title of *ealdormen*. The Saxon earl derived his title solely from his

office, which was originally in the gift of the crown, and in recompense for his services received a part of the revenues of his province to his own use. Toward the close of the Saxon dynasty these provincial governors not only greatly enlarged their authority, but claimed the dignity as hereditary; and in the time of Edward the Confessor the whole kingdom was divided between five powerful earls, including Godwin and his sons Harold and Tosti, of whom Harold subsequently usurped the throne. After the Norman conquest the territorial possessions of the Saxon nobility were declared forfeited, and with many newly created fiefs were distributed among the chief followers of William the Conqueror, who thereupon severally assumed the title of count, from the Latin *comes*. But this title was very soon replaced by the old one of earl, while the territory from which the new dignity received his name or over which he exercised jurisdiction was thenceforth called a county, instead of a shire as previously under the Saxons, and the consort of the earl became a countess. According to Cruise, there were three sorts of earldoms under the early Norman kings: the first and highest, where the dignity was annexed to the possession of a whole county, with the *jura regalia*, in which case the county became a county palatine, and the person created earl of it exercised all the authority of a sovereign; the next, where the earl was entitled to the third part of the revenues of the county court; and the third, where a tract of land was erected into a county and granted with civil and criminal jurisdiction to be held *per servitium unius comitatus*. This statement, however, is open to controversy, and Sir Harris Nicolas is of opinion that the Norman earls, excepting in the counties palatine, possessed no jurisdiction over the counties from which they were denominated, the dignity being of a nature altogether personal. At present the title conveys no local jurisdiction or revenue, and is no longer confined to the names of counties, but may be derived from those of towns or villages, or of families. It remained the highest hereditary dignity in England until the reign of Edward III., when the first dukedom was created, and is now the third order of the British nobility, being next below that of marquis, and above that of viscount. The style of an earl is "right honorable," and he is officially addressed by the crown as "our right trusty and well beloved cousin," an appellation attributed to Henry IV., who had his own reasons for flattering the powerful earls, with nearly all of whom he is said to have been allied by birth or marriage, by frequent allusions to the relationship. He bears also on some occasions the title of "most noble and puissant prince." The coronet of an earl consists of a circle of gold chased as jewelled, upon which rise eight pyramidal points, gold, each point bearing a large silver ball, while between the points close to the rim of the coronet are straw-

berry leaves of gold. The cap is of crimson velvet with turned ermine and a golden tassel. Earls are now created by letters patent, in place of the old practice by which the sovereign girded on the sword of the new earl and invested him with mantle and coronet. In 1872 there were 110 earls (and one countess) in the peerage of Great Britain, including 32 Scotch and 21 Irish earls; besides which there were 34 earls in the Scotch and 20 in the Irish peerage; 9 Scotch and 10 Irish earls had seats in the house of lords as representative peers.—The EARL MARSHAL is an officer of state in England, who directs important ceremonies, takes cognizance of matters relating to honor, arms, and pedigree, and proclaims the declaration of war or of peace. The office was established in the reign of Richard II., who conferred it upon Thomas Mowbray, earl of Nottingham, and is now hereditary in the family of Howard, the head of which, the duke of Norfolk, is the present earl marshal of England.

**EARLE. I.** *Pliny*, an American inventor, born in Leicester, Mass., Dec. 17, 1762, died there, Nov. 19, 1832. In 1785 he became connected with Edmund Snow in the manufacture of machine and hand cards for carding cotton and wool. Mr. Earle at first made them by hand, but soon invented the machine still in use for their manufacture, by which the labor of a man for 15 hours could be performed in as many minutes. Aside from his inventive genius, he deserves a record for his extensive attainments in science and literature. **II.** *Pliny*, an American physician, son of the preceding, born in Leicester, Mass., Dec. 31, 1809. He was educated at the Friends' school in Providence, R. I., where he was subsequently employed as a teacher. He received his diploma of M. D. in 1837, and in 1840 was appointed resident physician of the insane hospital at Frankford, Pa., where he remained about two years. In 1844 he was appointed physician to the asylum for the insane at Bloomingdale, N. Y., where he remained till April, 1849, when he visited the insane hospitals of England, Belgium, Germany, Austria, Poland, and a part of those of France. In 1847 he declined an appointment of visiting physician to the New York city lunatic asylum, but accepted it in 1853. In 1841 he published a small volume of poems entitled "Marathon and other Poems;" and in the same year "Visit to thirteen Asylums for the Insane in Europe." In 1848 he published the "History, Description, and Statistics of the Bloomingdale Asylum." After his return from his second European tour, he published in the "American Journal of Insanity" a series of articles on institutions for the insane in Germany and Austria, which were subsequently collected in a volume. Another series of articles on "Bloodletting in Mental Disorders" was published in 1854. His other contributions to the medical and psychological journals are very numerous. **III.** *Thomas*, a writer on law, brother of the preceding, born

in Leicester, Mass., April 21, 1791, died in Philadelphia, July 14, 1849. In 1817 he removed to Philadelphia, and engaged in mercantile pursuits for a few years, and afterward became distinguished as a lawyer and journalist. He edited in succession the "Columbian Observer," "Standard," "Pennsylvanian," and "Mechanics' Free Press and Reform Advocate." In 1837 he took an active part in calling a convention to revise the constitution of Pennsylvania, was a prominent member of it, and is believed to have made the original draft of the new constitution. At this time he lost the support of the democratic party by advocating the extension of the right of suffrage to negroes. In 1840 he was the candidate of the liberty party for vice president. After that period he mingled little in political affairs, and devoted himself almost entirely to literary pursuits. His first published work was an "Essay on Penal Law," which was followed by an "Essay on the Rights of States to alter and annul their Charters," a work which elicited the approbation of Thomas Jefferson; a "Treatise on Railroads and Internal Communications" (1830); a spelling book for schools; and a "Life of Benjamin Lundy." At the time of his death he had nearly completed a history of the French revolution.

**EARL MARSHAL.** See EARL.

**EARLY**, a S. W. county of Georgia, bordering on Alabama, bounded W. by the Chattahoochee river; area, 500 sq. m.; pop. in 1870, 6,998, of whom 4,172 were colored. The surface is a fertile plain, watered by Spring creek and several of its branches, and occupied by corn and cotton plantations, interspersed with forests of oak and yellow pine. The Chattahoochee is navigable along the border of the county by steamboats, and the smaller streams furnish good water power. On the bank of Colamoka creek is a remarkable ancient mound, 75 ft. high, with a level surface on the top 240 by 90 ft. in extent. The chief productions in 1870 were 129,092 bushels of Indian corn, 11,201 of oats, 22,614 of sweet potatoes, and 3,461 bales of cotton. The value of live stock was \$193,961. Capital, Blakely.

**EARLY, Jubal A.**, a general of the Confederate States, born in Virginia about 1815. He graduated at West Point in 1837, and was appointed a lieutenant of artillery, but soon resigned, studied and practised law, and was elected to the legislature of Virginia. During the Mexican war he was major of a regiment of Virginia volunteers. Upon the breaking out of the civil war he entered the confederate army, and commanded a brigade at Bull Run, Cedar Mountain, and Fredericksburg. In May, 1863, he commanded the division which held the lines at Fredericksburg, while Lee was fighting the battle of Chancellorsville. He also commanded a division at Gettysburg. In 1864 he was sent to the valley of the Shenandoah, where his operations were at first very successful. In July he crossed the Potomac, gained several actions,

and even threatened Washington, but was obliged to retreat. Toward the end of the month a portion of his cavalry advanced into Pennsylvania as far as Chambersburg, which they burned. He was defeated by Sheridan on the Opequan (Sept. 19), at Fisher's Hill (Sept. 22), and at Cedar creek (Oct. 19); and in March, 1865, he was totally routed by Custer at Waynesborough. On March 30 he was dismissed by Lee from the command in the valley. After the close of the war he spent some time in Europe, and returning resumed the practice of law at Richmond. In 1867 he published "Memoirs of the Last Year of the War."

**EAR SHELL** (*haliotis*), a marine gasteropod mollusk, so called from its resemblance in shape to an ear. The spire is small and flat, the aperture large and without operculum, and the interior pearly and iridescent; the exterior is dull, of a brownish or mottled color. The outer angle is perforated by a series of holes, growing smaller toward the spire, where they are closed, forming tubercles; these are the openings for the respiratory currents, and also for the passage of tentacles. The genus includes about 75 living species, and a few have been found fossil in the middle tertiary epoch; they are met with in the temperate and tropical seas the world over, and are used in Japan and in the Channel islands for food, being made tender by beating. The common species (*H. tuberculata*) is often called the ormer. Some of the species are 6 to 8 in. long and 5 or 6 wide. They are used for inlaying and other ornamental purposes, and also for decorating houses, fixed in the plastered wall. They are usually found in deep water, and are obtained at low tide, adhering very firmly to rocks by means of the large foot, like the limpet.

**EARTH**, the globe on which we live, and the third planet in order of distance from the sun. The earth is a rotating globe, somewhat compressed or flattened at the poles. Its mean diameter is 7,912 m., its polar diameter 7,898 m., and its equatorial diameter 7,926 m. It travels in a nearly circular orbit around the sun, at a mean distance of about 91,500,000 m. When nearest to the sun the earth is about 90,000,000 m. from him, and when at her greatest distance about 93,000,000 m. She completes her circuit around him in 365.2564 days, rotating on her axis in 23h. 56m. 4s. of mean solar time.—It was supposed by the first astronomers and geographers that the earth was a vast fixed plane, probably circular, and that the heavenly bodies were carried around this fixed earth, passing alternately above and below its level. The discovery that the earth is not a plane has been ascribed to Thales of Miletus (born about 640 B. C.), and it is said that he ascribed to it a spherical figure, but Anaximander judged it to be cylindrical. Gradually, as more and more of the earth became known through travels and explorations, its real figure and dimensions be-



came more clearly recognized. Voyages northward and southward were found to lead to a steady rising or sinking of the north pole of the heavens, a circumstance which showed that there must exist a curvature in that direction; while voyages eastward and westward, being found by careful observation to lead to a shortening or lengthening of the intervals between noon and noon, proved that in that direction also the earth is curved. We pass over the history of such researches, in order to give more space to the exact investigations of modern times. The measurements made on the assumption that the earth is a true sphere had been conducted to a sufficiently satisfactory issue exactly at the time when Newton's discovery of gravitation was about to lead him to the inference that the earth must be somewhat oblate. Picard showed in 1679 that each degree of a great circle of the earth contains rather more than 69 m., instead of 60 as had been supposed. Soon after Newton pointed out that if the earth were regarded as originally a homogeneous fluid rotating mass, its shape would not be globular, but so far compressed that the polar diameter would bear to an equatorial diameter the ratio 229 to 230. By a singular misapprehension the elder Cassini was led to imagine that if the earth were thus compressed the degrees of longitude must diminish as either pole is approached; an obvious mistake, seeing that the polar flattening implies diminished polar curvature. But Cassini's actual measurements seemed to indicate a diminution of the degrees of longitude toward higher latitudes; and when it was pointed out to him that his results were the reverse of what Newton's theory required, he maintained their accuracy, and the inference that the earth is a prolate instead of an oblate spheroid; in other words, he maintained that the polar diameter exceeds the equatorial. The controversy hence arising led to the famous earth-measuring expedition of 1735-'45. Bouguer, La Condamine, and Godin left Paris for Peru, where they were joined by Antonio d'Ulloa and Jorge Juan from Spain. Maupertuis with four others sailed to Bothnia, where they were joined by the Swedish astronomer Celsius. The measurements made in both places were most satisfactory, repeated observations leading to results differing only a few feet per mile. The length of the degree in Peru was found to be 362,790 ft., while the estimated length of a degree in Sweden amounted to 365,744 ft. The difference was far too great to be ascribed to errors of measurement, and it was justly regarded as demonstrative of the general accuracy of Newton's reasoning. However, the value actually ascribed to the compression by Newton (on a certain hypothesis as to the earth's structure) was not confirmed by these observations; on the contrary, it appeared that the compression was 1 in about 300, instead of 1 in about 230. Subsequent observations, as well as considerations founded on the attraction exerted by the moon upon the

bulging equatorial parts of the earth, have shown that the compression has not so great a value as Newton's hypothesis required; nor need we wonder at this when we remember that under the influence of attraction the interior parts of an originally fluid earth would necessarily be much denser than the outer parts, and that Newton himself only introduced the hypothesis of homogeneity to simplify his calculations. The following list of measurements of degrees in different latitudes indicates what has been done since such labors were first undertaken, and serves to show how satisfactorily all observations agree in pointing to an increase of the length of a degree with increase of latitude, whether north or south of the equator:

COUNTRY.	Latitude of middle of arc.	Arc measured.	Mean length of a degree at the middle latitude in feet.
Sweden .....	66° 20' 10" N.	1° 37' 10"'	365,744
Sweden .....	66 19 37	0 57 30.4	367,086
Russia .....	58 17 37	3 35 5.2	365,368
Russia .....	56 8 55.5	8 2 28.9	365,291
Prussia .....	54 58 26.0	1 30 20.0	365,420
Denmark .....	54 8 13.7	1 31 53.3	365,087
Hanover .....	52 32 16.6	2 0 57.4	365,300
England .....	52 35 45	3 57 13.1	364,971
England .....	52 2 19.4	2 50 23.5	364,951
France .....	46 52 2	8 20 0.3	364,572
France .....	44 51 2.5	12 22 12.7	364,572
Rome .....	42 19	2 9 47	364,262
United States .....	39 12	1 28 45.0	363,786
India .....	16 8 21.5	15 57 40.7	363,044
India .....	12 32 20.8	1 34 56.4	362,956
Peru .....	1 31 04 S.	3 7 3.5	362,790
Cape of G'd Hope .....	33 15 30	1 13 7.5	364,713
Cape of G'd Hope .....	35 43 20.0	3 34 34.7	364,060

These measurements are due to the following mathematicians and observers: The two Swedish to Svanberg and Maupertuis; the two Russian to Struve and Tenner; the Prussian to Bessel and Bayer; the Danish to Schumacher; the Hanoverian to Gauss; the two English measurements to Roy and Kater; the two French to Lacaille, Cassini, Delambre, and Mechain; the Roman to Boscovich; the American to Mason and Dixon; the Indian to Lambton and Everest; the Peruvian to La Condamine and Bouguer; and lastly, the two measurements at the Cape of Good Hope to Lacaille and Maclear. Later measurements made in India by Sir George Everest give 363,606 ft. for the length of a meridional degree in lat. 26° 49', and 363,187 ft. for the length in lat. 21° 5'. Combining all the observations, and attributing minor irregularities either to errors of observation or to local peculiarities of the earth's surface, we deduce the following table of the lengths of degrees of latitude in feet for every tenth degree:

LATITUDE.	Length of degree in ft.	LATITUDE.	Length of degree in ft.
0° .....	362,734	50° .....	364,862
10 .....	362,543	60 .....	365,454
20 .....	363,158	70 .....	365,937
30 .....	363,641	80 .....	366,522
40 .....	364,233	90 .....	366,361

It follows from the measurements that the compression of the earth is very nearly  $\frac{1}{230}$ . But it is believed that the compression is different for different longitudes; in other words, that the earth is not a figure of revolution. It will be interesting for the reader to compare the following three sets of results: First, as the result of comparing the best measurements before the recent Indian and Russian observations, we have—Earth's equatorial diameter 41,843,330 ft., or 7,924,873 m.; polar diameter, 41,704,788 ft., or 7,898,634 m.; difference of diameters or polar compression, 138,542 ft., or 26,239 m.; ratio of diameters, 302.026 : 301.026; compression,  $\frac{1}{230}$ ; length of degree at equator, 362,732 ft.; length of degree in lat.  $45^\circ$ , 364,543.5 ft. Secondly, Sir John Herschel thus states the results obtained by Capt. A. R. Clark, R. E., from a combination of all the results which have been obtained, and especially those resulting from the recent extension of the great arcs surveyed in India and Russia: "The earth is not exactly an ellipsoid of revolution. The equator itself is slightly elliptic, the longer and shorter diameters being respectively 41,852,864 and 41,843,096 ft. The ellipticity of the equatorial circumference is therefore  $\frac{1}{2383}$ , and the excess of its longer over its shorter diameter about two miles. The vertices of the longer diameter are situated in lon.  $14^\circ 23' E.$  and  $194^\circ 23' E.$  of Greenwich, and of its shorter in  $104^\circ 23' E.$  and  $284^\circ 23' E.$  The polar axis of the earth is 41,707,796 ft. in length; and consequently the most elliptic meridian (that of lon.  $14^\circ 23'$  and  $194^\circ 23' E.$  of Greenwich) has for its ellipticity  $\frac{1}{281}$ , and the least elliptic (that of lon.  $104^\circ 23'$  and  $284^\circ 23' E.$  of Greenwich) an ellipticity of  $\frac{1}{303}$ ." Thirdly, Gen. Schubert, in the memoirs of the imperial academy of St. Petersburg, arrives (by a mode of reasoning which Sir John Herschel regards as less exact) to a similar but not identical conclusion. "He makes the ellipticity of the equator  $\frac{1}{2385}$ ," says Herschel, "and places the vertices of the longer axis  $26^\circ 41'$  to the eastward of Capt. Clark's. His polar axis, as deduced from each of the three great meridian arcs, the Russian, Indian, and French respectively, is 41,711,019 ft., 41,712,534 ft., and 41,697,496 ft., the mean of which, giving to each a weight proportional to the length of the arc from which it is deduced, is 41,708,710 ft." It may be added that the figure of the earth as thus determined accords well with the observed change of rate in a pendulum set swinging in different latitudes, as also with the observed values of precession and nutation (the motions of the earth's globe caused by the attraction of the sun and moon on the protuberant mass round the equator).—Next to the determination of the earth's figure, that of her density may be regarded as the most important terrestrial problem which men of science have attempted to solve. Newton was the first to show how the problem might be attacked, since he first showed that a plumb

met would be deflected from the vertical by the attraction of a mountain. But Bouguer (born 1698) was the first to suggest that the method should be put in practice with direct reference to the problem of determining the earth's mass. The method is applied by means of the instrument called a zenith sector, a telescope with a graduated arc attached to its lower extremity and a plumb line to the upper. This telescope, pointed to the same star successively at two stations separated by a known distance, serves to show how much the centre of gravity changes in passing from one to the other; and it is known that for each 100 ft. of horizontal distance on a north and south line, the change of direction is very nearly one second of angle. But if one of the stations be at the foot of a mountain, the same change of direction is not observed, because the attraction of the mountain deflects the plumb line; and the effect is even greater if both the stations lie at the foot of a mountain, one on the northern side and the other on the southern. Thus, let us suppose that the two stations are separated by 4,000 ft.; then the difference in the direction of gravity would be about  $40''$  if the stations were on a plain; but if a mountain separates them, this difference will be increased, because the positions of the lower ends of the plumb line, already tending to convergence in consequence of the fact that the earth's gravity is directed always toward the centre of the earth, are brought yet nearer together by the mountain's attraction. If this difference is carefully determined, and if the geological structure of the mountain is known, as well as its general shape and dimensions, it becomes possible to compare the density of the earth with the known mean density of the mountain. This method was first applied by Bouguer in 1738, on the flanks of Chimborazo; but as both his stations were on the southern side, he was unable to determine the direction of the plumb line by means of such an instrument as the zenith sector; he failed accordingly to obtain any trustworthy results. But in 1772 Dr. Maskelyne proposed to the royal society to renew the experiment on some mountain in Great Britain. Schehallien was selected, and after a careful series of measurements and observations it was found that at stations separated by 4,364.4 ft. the difference in the direction of gravity was  $54.6''$  instead of  $42.94''$ , the difference due to gravity; so that the double attraction exerted by the mountain was found to be  $11.6''$ . By a series of calculations devised by Cavendish and carried out by Dr. Hutton, the density of the earth was computed to be to that of the mountain as 17,804 to 9,933; and after carefully examining the geological structure of Schehallien, Dr. Playfair inferred the probable mean specific gravity of the earth to lie between 4.56 and 4.87, that of water being unity. More recently Col. James, superintendent of the ordnance survey in Great Britain, has deduced a mean density

of 5.316 from observations made on Arthur's Seat, near Edinburgh.—Another method of determining the earth's density is based on the circumstance that the earth's attraction is less on a body raised to a considerable height above its surface than on a body at the sea level. Hence a pendulum of given length swings more slowly the higher it is raised above the earth's surface. Now if such a pendulum be taken to the summit of a mountain, it is clear that the reduction of the rate of swing will not be so great as the estimated reduction for the amount of elevation alone, simply because the attraction of the mountain will have an appreciable effect on the pendulum's rate. Thus as in the former case it becomes possible to compare the attraction exerted by the mountain with that exerted by the earth, and so to determine the density of the earth. From observations made on Mont Cenis by this method, Carlini and Plana deduced for the earth's mean density the value 4.950.—A third method may be described as the converse of that just mentioned. If a pendulum could be caused to swing at a great depth below the surface of the earth, it would swing more slowly than at the sea level. For, considering a spherical surface concentric with the earth's to pass through the place of the pendulum, the attraction of all the mass of the spherical shell outside that surface would produce no effect on the pendulum; while the sphere within that surface would exert a less influence on the pendulum than is exerted by the earth's mass on a pendulum at the sea level; for though the pendulum would be nearer to its centre, yet this cause could only be effective to increase attraction inversely as the squares of the radii of the two spheres, whereas the volume of the inner sphere would be less than the volume of the earth in the direct proportion of the cubes of the radii. But a pendulum placed at the bottom of a cavity, like a mine, would not have its rate reduced to the same extent, or might even have its rate increased. For, since the whole of the spherical shell just referred to exerts no attraction on the pendulum, the space dug out to form the mine should be occupied in order that the attraction of the shell should be *nil*; and when it is vacant there is wanting a portion of that matter whose attraction outward (or diminishing the earth's) is necessary to produce the equilibrium referred to. Failing, then, this attraction outward, the remainder of the shell in question must exert a certain amount of attraction inward, and according to the shape and extent of the cavity this attraction inward may cause the resultant attraction on the pendulum to be nearly or quite equal to, or even greater than, that at the sea level. And it is clear that if the geological structure of the region surrounding the mine is known, as well as the exact shape and extent of the mine, this method, like the last, supplies a means of determining the mean density of the earth. Prof.

Airy applied this method at the Harton colliery in 1854; but it is to be noted that he first tried the experiment, though unsuccessfully, in 1826 and 1828. "The two stations selected were exactly in the same vertical, excellently walled, floored, and ceiled. Every care was taken to secure solidity of foundation and steadiness of temperature. At each station (upper and lower) was mounted an invariable brass pendulum, vibrating by means of a steel knife edge upon plates of agate, carried by a very firm iron stand. Close behind this was a clock, and before it a telescope mounted so that coincidences of the pendulum of the clock might be accurately observed through a slit in front of the telescope. By this means the proportion of invariable pendulum swings to clock pendulum swings was found; and then, as the clock pendulum swings in any required time are denoted by the clock dial, the corresponding numbers of invariable pendulum swings at the two stations were determined. In order, however, to do this, the clock rates had to be frequently compared; this was done by means of an electrical apparatus. In this manner the pendulums were observed, with 104 hours of incessant observations, simultaneous at both stations, one pendulum (A) being above and the other (B) below; then with 104 hours, B above and A below; then with 60 hours, A above and B below; then with 60 hours, B above and A below. No less than 2,454 effective signals were observed at each station. The results showed that the pendulums suffered no injury in their changes, and that the acceleration of the pendulum on being carried down 1,260 feet was 214 seconds per day, or that gravity is increased by  $\frac{1}{135,146}$  part. It does not appear likely that this determination can be sensibly in error." From it, taking into account the structure of the region and the figure of the mine, Prof. Airy deduced for the earth's density the value 6.565.—The remaining method of determining the earth's density is that of comparing the earth's attraction directly with the attraction of large spheres of lead or other heavy metal. It was devised

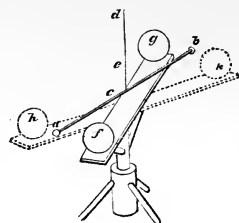

Michell's  
Torsion Balance.

by Michell, who also prepared the apparatus by means of which it was first applied by Cavendish in 1789. Two globes of lead, *f* and *g* in the engraving, are attached to the extremities of a strong horizontal bar, movable in a horizontal plane around its centre. Above this centre a light horizontal rod, *a b*, is supported by a fine wire. Two equal balls of lead, *a* and *b*, about two inches in diameter, are attached to the ends of this rod; and the proportions of the instrument are so adjusted

that the distance between these two small spheres (about 6 ft.) is equal to the distance between the two large ones. When the rod bearing the two small spheres is in as nearly perfect equilibrium as possible, the bar bearing the globes of lead is rotated on its vertical axis until these globes are brought nearly into perfect contact with the small balls on opposite sides, as at *f* and *g*. Their attraction on these balls being thus called into play, they tend to draw the light rod from its position of rest. The amount of the torsion thus produced in the supporting wire is observed through a telescope placed some distance off, so as to avoid disturbing influences. Then the bar is turned round in a contrary direction until the large balls are again nearly in contact with the small ones, as at *h* and *k*, so that the fine rod is swayed in a contrary direction from its position of rest, and the torsion thus caused is observed as before. The mean of the two results indicates the actual amount of torsion which the attraction of the two large globes is capable of producing. The experiments of Cavendish gave the attractive force exerted by two leaden spheres, each 174 lbs. in weight, as equivalent to  $\frac{1}{4375}$  of a grain weight, and he thence computed the density of the earth to be 5.48 times that of water. Reich of Freiberg, in two series of experiments, made the density 5.438 and 5.582. The late Francis Baily made more than 2,000 experiments by this method, and deduced from them a density equal to 5.660. It is worthy of notice how closely the results obtained by Michell's method (or, as it is called, the Cavendish experiment) agree together. The inference appears to be that this method is more trustworthy than any of those before described. It is also remarkable that Newton had stated in his *Principia* that probably the mean density of the earth is five or six times that of water (*Verisimile est quod copia materiæ totius in terra, quasi quintuplo vel sextuplo sit quam si tota ex aqua constaret*).—Sir John Herschel (*“Outlines of Astronomy,”* 11th ed., p. 559) thus sums up the evidence hitherto obtained respecting the earth's density and mass: “The final result of the whole inquiry will stand as below, the densities concluded being arranged in order of magnitude:

	Density.
Seehallien experiment by Maskelyne, calculated by Playfair.....	4718
Carlini, from pendulum on Mont Cenis (corrected by Ghilic).....	4950
Col. James, from attraction on Arthur's Seat.....	5316
Reich, repetition of Cavendish experiment.....	5438
Cavendish, result 5.489 corrected by Mr. Baily's re-computation.....	5448
Baily's repetition of Cavendish experiment.....	5660
Airy, from pendulum in Harton coal pit.....	6565
General mean.....	5441
Mean of greatest and least.....	5689

Calculating on  $5\frac{1}{2}$  as a result sufficiently approximative and convenient for memory; taking the mean diameter of the earth considered

as a sphere at 7,912.41 m., and the weight of a cubic foot of water at 62.3211 lbs., we find for its solid content in cubic miles 259,373 millions, and for its weight in tons of 2,240 lbs. avoirdupois each 5,842 trillions (= 5,842 × 10<sup>18</sup>).” The low specific gravity of the earth, compared with that which might be expected from the enormous pressure to which her interior parts are subjected and the compressible nature of their materials, has led some men of science to the conclusion that the temperature of the interior is sufficiently high to exert an important counteracting influence.—The principal motions of the earth are her rotation on her axis and her revolution around the sun. The main proofs of both these motions are found in the results of astronomical observation. The revolution of the earth around the sun is in particular placed beyond all possibility of question by the phenomenon called the aberration of light, which affects every star in the heavens, and is at once explained on the hypothesis of the earth's motion; while it remains absolutely without explanation, and even without the possibility of explanation, if the earth be regarded as at rest. And when the revolution of the earth is once admitted, her rotation must be admitted at the same time; for it would obviously be absurd to regard the sun's apparent annual motion around the heavens as due to a real motion of the earth around the sun, while at the same time the sun's apparent diurnal motion around the heavens was regarded as due to a real motion of the sun around the earth. But there are certain proofs of the earth's rotation which may be regarded as in a sense terrestrial, since they have no reference to the celestial bodies. Among these we may mention Foucault's experiments with the gyroscope and pendulum. The gyroscope as applied by him to this problem is a heavy disk or ring rapidly rotating in its medial plane, and so suspended as to be free to turn in any direction. Such a disk or ring tends to preserve the plane of rotation unchanged in position, and if the earth were not rotating would remain unchanged under the closest scrutiny. But as the rotation of the earth tends to change the position of the medial plane of the rotating body, the tendency before alluded to is called into action and causes the medial plane apparently to shift, while in reality it is only maintaining its position against the effects of the earth's rotation. The result is, that when carefully examined through a telescope the rotating disk or ring is seen to shift steadily in a direction opposed to that of the earth's rotation. Foucault's pendulum experiment depends on similar principles: the “plane of swing” of a pendulum tends to resist any motion by which it would be caused to take up a position intersecting its former one. Now, if a pendulum be set swinging in a north and south plane, a tangent to the arc of swing at its lowest point passes when produced through a point on the produced axis of the earth; and if the pendulum

continued to swing in a north and south plane while the earth rotated through any considerable angle, this tangent would continue to pass through the same point on the axis; in other words, the plane of swing would have taken up a position intersecting its former position. This at least would be the case for all points on the earth's surface except those lying on the equator. But the plane of pendulum swing resists the influence, thus causing it really to shift its plane, and therefore this plane apparently shifts from the north and south position; this apparent shifting being obviously greater or less according as the pendulum is further from or nearer to the equator. The experiments on this plan, when carefully conducted, have been found to accord perfectly with theoretical anticipations based on the theory of the earth's rotation. Another proof of the earth's rotation is founded on the fact that bodies let fall from a considerable height fall slightly to the east of the point which lies directly below the point whence they had been dropped. Newton showed that this should be the case, because the point of suspension, being further from the earth's centre than the point directly beneath it, has a greater velocity on account of the earth's rotation. The experiment is not an easy one, for many reasons; and it is only on the average of a great number of experiments that the tendency to easting can be established. Benzenberg in 1820 made a series of such experiments, letting 31 balls fall from a height of 235 ft., within a tower, upon a sheet of soft wax. He found the sum of deviation toward the north to be 46·4 Paris lines, toward the south 92·6 lines, toward the east 174·5 lines, and toward the west 50·5 lines. He repeated these experiments in an abandoned coal pit at Schlebusch in Rhenish Prussia, where the fall was 262 ft. Twenty-nine balls gave the following sums of deviation: toward the north 124 lines, toward the south 103 lines, toward the east 189 lines, and toward the west 42 lines. Lastly, a long and most convincing series of experiments was carried out on the same plan by Prof. Reich in the mines of Freiberg. He dropped 106 balls to a depth of no less than 488 ft. There was a balance of southerly deviations amounting to 48·76 lines, and a balance of easterly deviations amounting to 1,093·92 lines; so that the mean deviation toward the south was but 0·46 lines, or practically inappreciable, while the mean deviation toward the east was 10·32 lines. Thus we may regard the rotation of the earth as abundantly demonstrated, independently of any evidence afforded by the celestial bodies.—The various divisions of the earth's surface are described in the article GEOGRAPHY; its structure is treated in GEOLOGY. See also PHYSICAL GEOGRAPHY. The subject may be further studied in the following works: Steffens, *Beiträge zur innern Naturgeschichte der Erde* (Berlin, 1801); Ritter, *Die Erdkunde im Verhältnisse zur Natur und Geschichte des*

*Menschen* (2d ed., 19 vols., Berlin, 1822-'59), and other writings of the same author; Steinhäuser, *Neue Berechnung der Dimensionen des Erdsphäroids* (Vienna, 1858); Burmeister, *Geschichte der Schöpfung* (Leipsic, 7th ed., 1867); Sandberger, *Der Erdkörper* (Hanover, 1856); Berghaus, *Was man von der Erde weiss* (4 vols., Berlin, 1860); Figuier, *La terre avant le déluge* (8vo, Paris, 1862); Häckel, *Natürliche Schöpfungsgeschichte* (8vo, Berlin, 1868); Reclus, *La terre* (2 vols., Paris, 1867-'8; Woodward's translation, 1871); Newton's *Principia*; Laplace, "System of the World," (Harte's translation; Humboldt, "Cosmos," (5 vols., 1844-'58); Guyot, "Earth and Man" (revised ed., Boston, 1858); Sir John F. W. Herschel, "Outlines of Astronomy" (11th ed., 1872).

**EARTHENWARE.** See POTTERY.

**EARTHQUAKE**, a shaking of the solid ground by more or less violent movements, produced by natural forces. Such shakings, to which every part of the world is liable, are often imperceptible except to very sensitive instruments, but on the other hand are frequently productive of fearful destruction of life and property. These phenomena claim our special attention, since we must hope through them to make our next steps toward a full knowledge of the condition of the interior of our globe. After briefly considering the history of our knowledge of this subject as shown in its bibliography, we shall recount successively a few of the remarkable earthquakes, and shall then proceed to a short summary of our present knowledge of the subject, giving first some general views on the distribution of earthquakes, and then reviewing some of the many theories that have been broached in connection with this subject; in conclusion we shall give with some minuteness the remarkable results attained by Mallet and others who have lately established the science of seismology (Gr. *σεισμός*, earthquake) upon a firm basis.—Among the classical writers, Aristotle, Strabo, Seneca, Pliny, Josephus, &c., give numerous facts mixed with fanciful theories on the subject of earthquakes. In the earlier works of the modern revival of knowledge, Beccaria, Bylandt, Flamsteed, Percival, Priestley, Stukeley, and others, have sought with but little success by observations and theories to advance our knowledge of the origin of earthquakes; and with these we may class the memoir by Michell published in 1760. Of the works belonging to the present age of philosophical inquiry may be mentioned, first, those that treat specially of the phenomena of individual earthquakes, such as Kant, Roche, and Pereira, on the Lisbon earthquake of 1755; the report to the academy of Naples on the great earthquake of 1783 in Calabria; that of Palmieri and Scacchi on the Melfi earthquake of 1851; that of Volger on the earthquake of Viége, 1855; the report by Gilliss on his astronomical expedition to Chili, 1849-'52; and that of Mr. Mallet to the royal society at Lon-

don on the Neapolitan earthquake of 1857, which was published in 1862 under the title of "First Principles of Observational Seismology." Numerous special or general catalogues of earthquakes have been published, of which we note those of Von Hoff, Cotte, Hoffmann, Merian, and especially the great catalogue of Mallet, "The Earthquake Catalogue of the British Association," which very complete record embraces between 6,000 and 7,000 earthquakes recorded between the years 1606 B. C. and A. D. 1842. For the interval 1842 to 1872 the catalogues compiled by Perrey and published from time to time in the transactions of the Belgian royal academy form an almost exhaustive record. The special catalogues of Perrey for southern Europe, of W. T. Brigham for the United States, &c., may also be consulted. The catalogue by Scrope in his treatise on volcanoes (2d ed., revised and enlarged, 1872) is quite trustworthy for the most recent dates. Of theoretical works on the nature and origin of earthquakes there is scarcely any end, but among the few who have really advanced this branch of knowledge we may mention Dr. Thomas Young and Gay-Lussac, who seem to have remarked the similarity between earthquake shocks and the vibrations of sounding bodies, and Mr. Mallet, who, viewing all the phenomena with the eye of an expert mechanical engineer and by the application of rigidly exact measurements and inductive reasoning, has undoubtedly succeeded to a remarkable degree in perfecting our views of the forces acting during an earthquake, and advanced our knowledge of the ultimate origin of the initial disturbance. The intimate connection between the phenomena of geology on the one hand and of volcanoes and earthquakes on the other has been treated of with more or less fullness by Babbage, Élie de Beaumont, Leopold von Buch, Dana, Darwin, Daubeny, Forbes, Herschel, Hopkins, Höttingen, Humboldt, Hunt, Lyell, Murchison, Phillips, Ritter, Rogers, and Scrope; and the established laws of dynamics, of heat and of strength of materials, have been applied with much success to the question of the origin of these disturbances by Haughton, Hopkins, Oldham, Prévost, Thomson, and especially by Mallet (see his preface to Palmieri's "Vesuvius," London, 1873). Of general treatises, that by Prof. J. D. Whitney, "Earthquakes, Volcanoes, and Mountain Building" (New York, 1871), and that by Prof. Boccardo, *Seismopirologia* (Genoa, 1869), are among the most recent. The essay by Mallet lately presented to the royal society promises when printed in full to mark an epoch in the science of seismology. Interesting matter will also be found presented in a popular style in Reclus on "The Earth."—*Memorable Earthquakes*. In southern Italy and Sicily no century has elapsed since the earliest periods of history that has not been distinguished by severe if not frequent earthquakes. From 1773 to the end of 1776 this region was almost

constantly disturbed; no fewer than 947 shocks were experienced in the first of these years, of which 501 were of the first degree of force. Lyell observes that great importance attaches to these from the minuteness of the observations of men competent to collect and describe with accuracy the physical facts that throw light on geological questions. The great earthquake of 1783 in Calabria probably caused the death of 100,000 persons, and was felt in a great part of Europe; it was fully described by the commission of the Neapolitan academy. The origin of the shock was at a spot under the centre of Calabria; the disturbance passed under the sea without producing any great sea wave, but on reaching the opposite coast of Sicily destroyed the city of Messina. The destructive sea wave that entered the harbor of the latter city was not propagated across the sea, but was probably caused by the dislocation of large masses of rock that fell into the waters near Messina. In central Italy, among the earliest of the recorded earthquakes is that of the year A. D. 63, which resulted in the partial destruction of Herculaneum and Pompeii, 16 years previous to the time when those cities were buried under the lava and ashes accompanying an eruption of Vesuvius. The earthquake of 1857 in the kingdom of Naples is the most noteworthy that has occurred there during the present century, not only because of its extent and fatal violence, but even more so because of the masterly investigation to which its phenomena were submitted by Mallet on behalf of the British association for the advancement of science. This earthquake was felt throughout the kingdom of Naples; in the city itself comparatively slight damage was done, the chief scene of the destruction being in the provinces. The velocity with which the wave of shock spread in all directions from its origin near the town of Potenza was about 775 ft. per second. Of the many suggestive results of Mallet's investigation we shall have occasion to speak further on.—The earthquake of 1855, known as the earthquake of Viège, has been carefully studied by Volger. It was felt slightly in Paris, Mentz, and Geneva; the region of greatest violence was between Bern, Lugano, and Chamouni; the velocity of translation of the wave of shock was northward 2,861 ft. per second, but southward only 1,391 ft. On Nov. 14, 1861, another great earthquake occurred in Switzerland, simultaneously with which it was noticed that in the artesian wells at Passy, Paris, the sediment suddenly increased from 956 to 2,268 grains per cubic metre, after which it began to decrease. In general it has been noted that the springs of this place are similarly affected by almost every earthquake of western Europe.—In Portugal, the city of Lisbon was visited on the morning of Nov. 1, 1755, by one of the most memorable earthquakes recorded in history. The rumbling sound that precedes most earthquakes was immediately followed by the great shock which

threw down the principal portion of the city. The sea retired, leaving the bar dry, and returned in a minute as a great wave or breaker 50 ft. or more in height. It is believed that 60,000 persons perished in the space of six minutes. The part of the city that was permanently engulfed beneath the waters of the bay was covered to the depth of 600 ft. The portion of the earth that was shaken by this earthquake was estimated by Humboldt as equal to four times the extent of Europe; but many of the reports and estimates in reference to it have been greatly exaggerated, and from more exact considerations Reclus states that probably an area equal to six times that of France was sensibly disturbed. The shock was felt in the Alps and on the coast of Sweden; in Bohemia the warm springs of Teplitz disappeared for a time, and again burst forth, deluging the region with ochre-stained waters. Many towns were destroyed in northern Africa. The waves of shock reached Scotland, probably passing under it, causing temporary changes in the waters of Loch Lomond, which suddenly rose more than two feet and then fell to below their usual level. Almost if not quite simultaneously there began the great eruption of the volcano of Kōtluggia in Iceland. The velocity of propagation of the wave of shock was about 2,000 ft. per second, and its origin was probably under the ocean some distance west of Portugal. The great sea wave that swept over the coast of Portugal was nearly 60 ft. high at Cadiz, and extended to Madeira, and possibly to the West Indies. The numerous other earthquakes and earthquake waves experienced during the same month throughout Europe and America may very probably have had some connection with that at Lisbon, but are not to be confounded with the shock of Nov. 1.—In Syria, the Biblical records preserve notices of earthquakes in the reign of Ahab, about 900 B. C., and again in the reign of Uzziah, about 800. The earthquake that devastated Judea at the time of the battle of Actium, 31 B. C., was such as according to Josephus had never happened before, and caused the death of 10,000 persons. That which occurred at the crucifixion was accompanied by a darkness very similar to that recorded Jan. 22, 1835, in Central America, on the occasion of the eruption of the volcano Coseguina and the attendant earthquake. The ancient city of Antioch has been peculiarly visited from time immemorial. Besides many other instances, the following may be especially noted: The city was almost destroyed A. D. 115, at the time of the visit of the emperor Trajan, who was himself hurt. In 458 it was again visited, and in 526 occurred the most disastrous one of which any record has been preserved; Gibbon states that 250,000 persons are said to have perished at this time. Sixty years later, in 587, an earthquake destroyed 30,000 persons. The last occurred there in April, 1872.—In India, by the

earthquake of 1819, a tract of 2,000 sq. m. of country near the mouth of the Indus was submerged, and a neighboring region elevated into a mound. The great earthquake of Jan. 10, 1869, has been studied by Oldham with results of great value. The origin of the shock was a point under Asaloo, somewhat deeper down than in the Neapolitan earthquake as investigated by Mallet. Eruptions of sand and hot water took place through the fissures, forming cones. The entire lower valley of the Ganges was embraced in the field of disturbance, and the shock was felt quite decidedly at Calcutta.—In mid ocean there are certain regions frequently visited by earthquakes, if we may rely on the testimony of those navigating them. Among these may be specially designated the portion of the Atlantic ocean near the equator and about half way between Guinea and Brazil.—In the United States, in 1811, occurred the famous earthquake of New Madrid in Missouri, in the valley of the Mississippi river. Humboldt remarks that it presents one of the few examples of the incessant quaking of the ground for several successive months far from any volcano. Over an extent of country stretching for 300 miles southward from the mouth of the Ohio river the ground rose and sank in great undulations, and lakes were formed and were again drained. The surface burst open in fissures that generally trended N. E. and S. W., and were sometimes more than half a mile long; from these fissures mud and water were often thrown as high as the tops of the trees. During the continuance of these convulsions the inhabitants distinguished two classes of movements, the vertical and the horizontal; the latter were regarded as far more desolating than the former. The disturbances continued over what has since been called "the sunk country" until March 26, 1812, when they ceased coincidentally with the great earthquake of Carácas. The most severe earthquake that has been recorded in the middle and eastern states was that of Nov. 18, 1755. The shock then felt in New England was undoubtedly a wave promulgated from either the same centre whence emanated the tremendous disturbance that had destroyed Lisbon on the first day of the month, or from a centre whose activity had been stimulated by the continual quakings that then prevailed from Iceland to the Mediterranean. This earthquake of the 18th began in Massachusetts with a roaring noise like that of thunder; after a minute's continuance of this there came the first severe shock with a swell like that of a long rolling sea—a swell so great that men in the open fields ran to seize something by which to hold on lest they should be thrown down. After two or three lesser shocks there came the most violent of all, producing a quick horizontal tremor with sudden jerks and wrenches; this continued two minutes, and after a slight revival died away. Numerous other shocks followed in the course of a month. In Boston the main shock threw

down or dislocated and twisted many chimneys, wind vanes, brick buildings, &c., and throughout the country it threw down the rude stone walls bounding the farms; new springs of water were opened; the vessels in the harbor felt the shock; large numbers of fish were killed and floated on the surface of the water. Nine hours afterward, at 2 o'clock P. M., a sea wave 20 ft. high, that had undoubtedly originated at the source of this earthquake, arrived at the harbor of St. Martin's in the West Indies. On Oct. 19, 1870, occurred the most considerable shock that has been observed in the middle and eastern states during the present century. The source of this disturbance has been traced with some probability to the volcanic region 50 to 100 m. N. E. of Quebec; from this region the shock spread to St. Johns, New Brunswick, and thence was felt westward to Chicago and southward to New York. The velocity of the wave of shock was about 14,000 ft. per second. The occurrence of the shock felt at Quebec was telegraphed to Montreal by the operators of the Montreal telegraph company in time to call the attention of those at the latter city to the phenomena about 30 seconds before the shock reached them. In California, the earthquake of 1852 destroyed one of the southern missions. That of March 26, 1872, was the most severe that has occurred there during many years; special damage was done in San Francisco by the cracking of the walls of fine public buildings. In Nevada, the mining regions suffered in 1871 by the destruction of Lone Pine and other settlements. In Mexico a disastrous earthquake occurred June 19, 1858. It extended throughout the valley of Mexico, demolishing the aqueduct that supplies the city with water; it was felt in most of the surrounding provinces, where it also did great damage, and was in some places recorded as being the most severe ever experienced there.—In the West Indies, subject as they are to very frequent shocks, we need only note that of June 7, 1692, by which Port Royal, the capital of Jamaica, was in less than three minutes sunk beneath the sea. The fissures produced in the earth opened and closed so rapidly that in some cases, it is said, the lower parts of the bodies of persons were buried while the upper portions remained above ground.—In San Salvador, near the capital, is a volcano that was thrown up in 1770, and which is very similar to Stromboli in the regularity of its intermittent eruptions; it has remained in a state of constant activity, and continues to increase in size by means of the accumulation of ejected lava, ashes, &c. Its origin was preceded by earthquakes for several months, and on Feb. 23, 1770, by the opening of a crevice whence issued lava, ashes, smoke, and flame. On March 19, 1873, San Salvador was utterly destroyed. Three successive severe shocks were experienced; but the inhabitants were by the previous noises so well warned that a comparatively small loss of life (less than

500) took place. The frequency of earthquakes in this region is expressively told by the name given to it by the aboriginal Indians, Cuscatlan, "the land that swings like a hammock."—In South America, the city of Caracas, Venezuela, was entirely destroyed by three shocks within 50 seconds on March 26, 1812. In Ecuador, the city of Quito was almost destroyed on March 22, 1859. On Aug. 16, 1868, a terrible earthquake devastated a large part of Ecuador; this was one feature in the series of severe shocks that between the 13th and 16th were experienced over nearly the whole of the southern half of the eastern coast of the Pacific ocean. In Peru, Callao was destroyed in 1586; the accompanying sea wave must have been about 90 ft. high, and resulted from the joint action of two shocks. It was again destroyed in 1746. On Aug. 13 and 14, 1868, the seaport of Arica suffered severely; and during several days there occurred numerous shocks throughout the coast region from lat. 10° to 25° S. The earthquake sea wave was specially destructive (see ΔΡΟΑ), and it sped thence across the Pacific ocean, reaching the Hawaiian islands on the 14th and Yokohama on the 15th; it was also felt on the coasts of Australia and of Alaska. Among the numerous earthquakes that have visited Chili we will mention three very instructive ones. That of 1822 is interesting historically, because the accounts given of certain twisting effects led Mallet to enter upon those dynamical studies that have done so much to elucidate the obscure points in seismology. The earthquake was itself a very severe one, and specially interesting, since in connection with it there occurred a permanent elevation to the extent of from two to seven feet of fully 100,000 square miles of land lying between the Andes and the coast; lines of sea beaches at higher levels and further inland indicate the previous lifting up of the same region at different times along the same lines. About midnight of Feb. 20, 1835, the city of Concepcion was for the fourth time destroyed; there were felt over 300 successive shocks within two weeks; the accompanying sea wave was 30 ft. high, and probably originated near the island of Juan Fernandez, where there also simultaneously broke forth a submarine volcano, which sent up a column of fiery ejecta through a depth of 400 ft. of water; about the city of Concepcion the sea water was black and of an offensive smell, killing many fish. Among the numerous earthquakes observed by Gilliss during his astronomical expedition to Santiago was that of April 2, 1851, the most severe since 1822. The heaviest portion continued a minute and a half, within which interval were experienced continuous rumbling and innumerable severe shocks or oscillations. The movements of pendulums and other free bodies were nearly in the meridian. The warning rumbling noises preceded the shock by about 15 seconds. The earthquake was severely felt over a region extending 200 m. N. and



S., and at least 100 m. E. and W.; the point of greatest severity was apparently 30 m. S. of Santiago, though at all places visited by it it seemed to come from some point further south. This earthquake was one of the cases, extremely rare in Chili, in which the origin of the disturbance was under the mainland, and where therefore no great sea wave was produced. In the Argentine Republic, Mendoza was overturned in March, 1861; the shock was very severe, and continued from the 20th to the 23d over Buenos Ayres and the entire confederacy, and 12,000 persons are estimated to have perished.—In the Hawaiian islands, the most severe earthquake ever known occurred on Feb. 19, 1871. At Honolulu it lasted 50 or 60 seconds, the motion being chiefly vertical with a N. E. and S. W. rocking movement; a roaring sound that was also heard far out at sea preceded the shock, and it was noticed that vessels that lay furthest from the wharves were first struck, and afterward those close to the shore. At Lahaina the direction of the vibration was S. and N. On the W. coast of Hawaii the shock was as severe as on the S. coast of Oahu; it seemed to come from the west. The various observed phenomena point to a centre of disturbance near the centre of the circle in the circumference of which is the group of islands.—In the East Indies is a seat of almost perpetual volcanic and earthquake activity. In 1772, during an eruption of Papandayang, one of the loftiest volcanoes of Java, an area of 100 sq. m. was overwhelmed with ashes (not submerged under the sea), destroying about 40 villages and 3,000 inhabitants. Simultaneously eruptions took place from two volcanoes respectively distant 184 and 352 m. from Papandayang, although the many neighboring volcanic vents were quiet. On July 3, 1863, the city of Manila was much damaged by a violent earthquake; two systems of shocks were experienced, trending respectively in a N. to S. and E. to W. direction. The islands of Japan are subject to numerous violent disturbances. The earthquake of Dec. 23, 1854, which destroyed the ports of Simoda and Osaka and injured the city of Yedo, was accompanied by a sea wave 30 ft. high, which made the destruction more complete, and then swept eastward over the Pacific ocean in a series of five or seven waves that were felt a few hours later at the Bonin islands and on the California coast, affording Bache an opportunity to determine approximately the average depth of the water.—*Registration of Earthquakes.* The observations of the nature of earthquake shocks have heretofore been generally indefinite and unsatisfactory. Every disturbed stone or other object forms of itself a permanent record of the force and direction of the shock, but the difficulty of properly interpreting the often complex results has led to the suggestion of a system of automatic registration by means of permanent simple instruments called seismographs, of which the following

are some of the principal: 1. Horizontal plates of glass, wood, or stone, strewn with sand or loose blocks of various sizes, densities, and proportions, show by the changes impressed on the positions of the movable materials the direction and force of the horizontal components of a shock. 2. Tide gauges record not only the great sea wave, but also the smaller forced waves that precede this, and therefore give the means of determining the time of the occurrence as well as other data. 3. Similarly, the self-recording mercurial barometer, if sufficiently sensitive, records the time and also the force of the vertical component of the shock. 4. The delicate levels of the accurate astronomical instruments give information of the slightest change of level, and have in the hands of Wagner recorded vibrations that would otherwise have wholly escaped the senses. 5. An accidental observation of Gilliss, who happened to be viewing the moon during a slight earthquake, shows that by means of a telescope sighted on celestial or distant terrestrial objects we may become aware of the slightest imaginable vibrations, which may be recorded photographically. 6. The telegraph as used by Gilliss at Santiago in 1852, and by the operators in Montreal in 1871, may be used especially with a chronograph to record the times of transit of a shock as it passes several stations successively. 7. The self-recording magnetometers afford a very delicate record of the changes affecting the suspended needle, and also of the effect of the shock on the magnetic condition of the globe. 8. Pendulous bodies (neither barometers nor magnetometers, but simple pendulums) have long offered a favorite mode of observing the direction of the shock, which is the same as the azimuth of the axis of the ellipse described by the pendulum in consequence of the disturbance; the force of the shock is recorded by the extent of the arc of vibration. 9. Vertical spiral springs, from which weights are suspended or upon which they press, afford very delicate means of observing and recording the vertical component of the force. 10. The Cacciatore seismometer consists simply of a basin filled to the brim with mercury; at the eight points of the compass are small holes through which the liquid may be projected by the force of the earthquake shock. 11. Lamont's apparatus consists of finely balanced needles, to which may be attached small mirrors throwing a reflected beam of light into a telescope, so that the slightest movement may become visible. 12. The most complete instruments for self-registration are those employed by Palmieri, Kreil, and Mallet, but the last is far more perfect than any other. Palmieri's apparatus consists of a fillet of paper drawn along uniformly, on which are made marks corresponding to the times and extent of the disturbances communicated by the vertical component of the shock to certain weights hung on spiral springs; for

the horizontal component Palmieri employs four open U-shaped tubes partly filled with mercury; they are so set up that the planes of the tubes are directed toward different points of the compass; when the earthquake shock disturbs the quiescent mercury, a galvanic current is made or broken, by which the time record is made on a moving fillet of paper; light floats are also disturbed, and show by the extent of their movements the force of the shock. 13. The preceding instrument has some points of resemblance with that first proposed in 1846 by Mallet; the latter is however calculated to resolve with greater ease and accuracy all the problems connected with terrestrial waves of shock. Mallet employs one vertical and four horizontal L-shaped glass tubes, each separated from the other and filled for a short distance with mercury; the mercury being originally in a quiescent state, the linear motion that is communicated to it relative to the sides of the tubes by the wave of shock breaks or makes a galvanic circuit by which the time is recorded on a revolving cylinder; the extent of the vibrations of the mercurial column is also recorded by appropriate dots or lines, and the apparatus is so placed that we are able to deduce the movements of the earth in three directions, vertically, meridionally, and at right angles thereto, whence the angle of emergence and all the other local phenomena may be calculated. 14. Kreil of Vienna proposed in 1855 to employ a pendulum suspended by two independent springs, of which the lower for instance allowed of motion in the meridian, but the upper in a plane at right angles thereto; the movement of the pendulum is recorded by its lower end marking on a revolving disk of paper or metal.—*Connection between Earthquakes and Volcanoes.* The intimate relation of these phenomena is apparent at once to even the most careless observer, but correct and exact ideas on the subject have been attained only within the present age. On the one hand, earthquakes are most numerous in the volcanic regions of the globe; on the other, they are not at all confined to these centres; they are sometimes attended by the growth or formation of volcanoes, and in general no volcanic activity is manifested without being attended by more or less notable earthquakes, the quakings being however to a great degree confined to the volcano in eruption; the only exception to the latter statement can indeed be shown to be explicable in such a way as to give further confirmation of the general statement that the strains, pressures, and explosions occurring within the depths of the solid earth give rise at the surface of the globe, if feeble, to slight earthquakes, and if stronger, to more severe shocks accompanied by upheavals and depressions; if yet stronger, though not paroxysmal, to the formation of fissures, volcanic vents, and eruptions of steam, gases, hot water, mud, scorïæ, ashes, lava, and flying stones. A slight earthquake central in

a non-volcanic region is "an uncompleted effort to establish a volcano." The presence of a volcano is demonstrative of a previous earthquake, and the volcanic vent, offering as it does a way of easy escape for gases, &c., is, unless it becomes clogged up, to some extent an assurance that subsequent earthquakes in its immediate region will be of less severity. The area thus protected may extend to a distance of 100 miles from the volcano, but is usually much less, showing that within the earth's surface the centres of the origin of earthquake disturbances are often quite insulated. The exceedingly great variety in the strata of the earth and the nature of the volcanic eruptions necessitates a special study of the individual cases, in order to perceive how intimately and yet how diversely these phenomena are associated with every variety of earthquake.—*Atmospheric Relations.* The connection between the atmosphere and the earthquake, though probably incidental, is an important one. It is found that there is a decided increase in the frequency and severity of shocks during the rainy season, at least in certain localities, and especially, as Mallet says ("First Principles of Seismology," 1862), in very dry countries such as Asia Minor and Syria, and in the volcanic regions where eruptions of steam prevail, and where the melted snows and heavy rains are rapidly drained off into deep fissures. There seems to be no reasonable doubt that in these cases the pressure of the drainage water directly affects the liquid in the interior of the earth, and increases the supply of both steam and lava for the volcanoes, as well as the liability to such internal explosions of steam as may originate the earthquake shocks. That the diminution of atmospheric pressure such as prevails over the central regions of some severe storms, or during certain seasons, cannot directly be of importance in comparison with the above mentioned more powerful hydrostatic pressure, seems quite evident; yet there are volcanoes, such as that of Stromboli, where the conditions of equilibrium are so delicately adjusted that, according to the testimony and traditions of those living in their neighborhood, their activity increases perceptibly on the approach of every storm.—*Geographical Distribution of Earthquakes.* Besides the preceding general relations between earthquakes and volcanoes, it is important to consider the distribution of the former, or rather their segregation in certain well marked regions. It is not necessary in this place to enumerate the regions of volcanic activity, although these are peculiarly also subject to earthquakes. (See VOLCANO.) The regions that are far removed from active volcanoes, yet specially subject to earthquake shocks, are, in the order of the severity of the phenomena, the Himalaya mountains and India, Syria, Algeria, the W. coast of North America, the Mississippi valley, Scotland, New England, and the Saint Lawrence valley. The re-

gions that are at present comparatively free from sensible earthquakes are Egypt and the eastern and southern portions of Africa, northern Europe and Asia, Australia, many portions of North America, the eastern portion of South America, and Greenland.—*Chronological Distribution of Earthquakes.* The contortions of geological strata, their faults and fissures, and still more the presence of old trap dikes, &c., that break through every known geological formation, sufficiently show that in every part of the world earthquake phenomena have been common at some time throughout the entire history of the globe since the formation of its solid crust; indeed, we have in these phenomena the record of the condition of the interior of the earth at successive stages separated by long intervals of time. The periodicity of earthquakes has been studied by many writers, of whom among the earliest was Merian, whose conclusion, confirmed by Mallet, Perrey, Volger, Kluge, Bridgman, &c., was that these occur more frequently in the winter than in the summer months, as for instance in New England, Bridgman finds that between 1638 and 1869, of 227 earthquakes, 148 occurred during the winter half of the year, and 74 during the summer half. If this were an annual period independent of the wet and dry climatological seasons before alluded to, it would be of deep import; but on the contrary it is less marked in some countries than in others, its laws being apparently peculiar to the various centres of shock; it has therefore been treated in the preceding section as one depending on climatological considerations. Mallet has indeed shown that, considering the whole world in one view, there is a preponderance of shocks recorded in certain months; but it is possible, as he states, that this preponderance results from the greater fullness of the records relating to them for the northern hemisphere. A daily period has also been recognized, such that more shocks are recorded during the day than during the night. This periodicity, which has been demonstrated for Switzerland, if it (as thus enunciated) be a law of nature, will be so neutralized by the corresponding daily period of the antipodal regions, that in the total sum of the earthquakes over the whole earth no such period will be noticed. The gradual diminution and ultimate cessation of earthquakes, as maintained in 1771 by Castilhon, and the periods depending on hurricanes and on electric phenomena, are all too poorly established to be worthy of more than a passing mention. Thus also must we dismiss the attempts of Falb and others to predict earthquakes for any considerable period in advance. The other periods of really cosmical importance are as follows: 1. That depending on the variations in the solar spots. 2. That depending on or connected with terrestrial magnetism. These two classes of phenomena, however, have as yet not been so well established as is necessary to their full acceptance. Lamont (1840), Varley (1870),

and Sumichrast (1871) trace a connection between terrestrial magnetism and earthquakes, though they differ as to whether the former is to be considered as the cause or the consequence of the latter; most likely is it that both are consequences of a deeper common cause; in either case, however, there results a periodicity of earthquakes allied to the known periods in terrestrial magnetism. 3. The periods demonstrated by Perrey to be connected with the moon's phases. 4. That discovered by Palmieri for Mount Vesuvius, the violence of whose eruptions perceptibly increases twice in the solar day in a manner similar to the ebb and flow of the tide. Both these latter may possibly be actual laws, though the modes of their connection are quite unknown and are likely to prove very complicated. 5. The quasi-periodical alternation of force announced by Mallet in his fourth report, such that a season of many severe shocks is followed by one of very few and sometimes slight shocks. 6. Mallet also detects indications of an increase in the frequency of earthquakes about the middle and end of each century. 7. The periodicity suggested by the facts first published by Humboldt, who remarked that in Mexico, South America, and the United States, the centres of earthquake influence seem to change their positions. Perrey and Mallet, agreeing with Miraldi and with the ancient traditions of Italy, announce the same fact for that peninsula; in it the numerous earthquake centres follow the general line of the ridges of the Apennines, as indeed Mallet has shown to be the rule over the whole world; but further it is shown that in Italy each of these centres has apparently a slow secular movement along the general line, so that its greatest energy is not recurrent at the very same spot, or not until after a long period.—*Physical Changes produced by Earthquakes.* Permanent upheavals and depressions affecting the physical geography of large regions of the earth are considered as being on an extended scale manifestations of the same force that suddenly elevates and depresses smaller districts at the moment of an earthquake. Dana, Lyell, and others, presume that extended changes take place with extreme slowness and comparative quiet; and Prévost, Dana, Mallet, and others, attribute these to the influence of tangential pressures and to the slow cooling and contracting of the earth. Beaumont and others ascribe the elevation of the great mountain chains to single upheaving shocks, with of course accompanying earthquakes of the greatest severity. The former views have now far more adherents, they being more in accordance with the customary modes of operation in nature; it is however not to be denied that both methods of operation are admissible. Of sudden changes may be noticed the elevations during the earthquake at Concepcion in 1835, and the depressions attending the shock at Lisbon in 1755. Of slow movements we find examples in the upheaval of the Scandina-

vian peninsula, which is now proceeding at the rate on its eastern coasts of five feet per century. About one half of the islands of the Pacific ocean are believed to be rising, as also the island of Spitzbergen, the West Indies, and the whole of the W. coast of South America. Among the most remarkable slow depressions are the case of the southern portion of Greenland, the numerous coral-reefed islands and atolls of the Pacific, and the countries of Holland, Belgium, Denmark, and the S. shore of the Baltic sea. In North America the most notable well established case of depression is that now in progress along the Atlantic coast from Cape Cod to Cape Hatteras, which region is calculated to be sinking at the rate of about two feet per century.—*Earthquake Waves.* This term is commonly applied to the great oceanic waves that attend such earthquakes as originate under the ocean. These waves while in deep water are merely very long but decided swells; in traversing shoal water they become more marked, and on nearing the shores often break most disastrously upon them, being in this case preceded by a rapid fall of the water, as is the case in ordinary breakers. The numerous cases that have been cited in a former section of this article suffice to show how prominent a feature of a disastrous earthquake are these sea waves. On account of their sudden definite origin and their vast size, these waves have on several occasions afforded a reasonable basis, in connection with the received principles of wave motion, for an approximate computation of the average depth of the sea over which they may have passed. A fine example of such a computation was given by Prof. Bache in the case of the waves that rolled into the harbors of Simoda, Osaka, Peel's island, San Diego, and San Francisco, in December, 1854. These waves apparently started from a point near Simoda, and on reaching the American coast were recorded on the self-registering tide gauges of the coast survey. The crest of the highest wave experienced at Simoda was 30 ft. above the average sea level at 9h. 30m. A. M., local time; the highest at San Francisco was 0.45 of a foot above the normal height of the water, and occurred about nine hours after the wave at Simoda. From these and other data Prof. Bache concluded the mean depth of the intermediate Pacific ocean to be between 2,100 and 2,500 fathoms. The wave attending the Arica earthquake of Aug. 13, 1868, also extended over the entire Pacific ocean; from the records at four tidal stations of the United States coast survey, and the observations made at eight other points, including Australia, Hilgard (1872) concluded that the eastern equatorial portions of the Pacific are the deepest, while the depth of the northern portions seems quite small.—*Nature of the Earthquake Shock.* The discovery of the true nature of the earthquake, to say nothing of its ultimate origin or cause, for a long time baffled the labors of mankind; the application of a purely inductive train of

reasoning has always been difficult, because of our own inability to experiment on the earth on so large a scale as was necessary, and because of the absence of exact observations and records. The principal results arrived at previous to or independently of Mallet's dynamical studies have been already given in the generalizations under the head of geographical distribution, &c. The history of the numerous hypotheses and crude theories that have been advanced from time to time in reference to the nature of the earthquake shock may be thus briefly summarized. Up to the beginning of the 17th century no views other than the most indefinite and superstitious notions seem to have been propounded and accepted. In 1679 Travagini suggested that the successive shocks are pulses of force. Flamsteed in 1693 considered that vibrating air caused the earth to tremble, as in ordinary thunder. During the 18th century Buffon and others used the term concussion in speaking of the movement of the earth; and an anonymous French author in 1756 maintained that chains of mountains are long levers, so that a slight movement at one end will be felt as a blow or earthquake shock at the other. Since this period all students have recognized the phenomena as those of a concussion, except perhaps Michell, who in 1760 announced his theory that the surface of the earth heaved like the swell of the ocean, or even like a wave; a view adopted in some respects in 1843 by H. D. and W. B. Rogers to explain the plication of the strata of the Alleghanies. In 1807 Dr. Thomas Young suggested the probability that the motion of the earth at any point is a vibratory one, and that it is propagated through the earth in a manner analogous to that of waves of sound; but he appears to have made no clear distinction between the subterraneous waves of shock and sound. Similar views were adopted in 1823 by Gay-Lussac. In 1846 Mallet published his work on "The Dynamics of Earthquakes," in which, without specially indicating the ultimate origin of the earthquake, he very clearly presents views that are now widely accepted as to the true nature of the phenomena observed at the surface of the earth. These views are substantially as follows: An earthquake is the passage past the observer of a wave of elastic compression, in any direction from vertically upward to horizontally through the crust and along the surface of the earth, from any centre of impulse or from more than one, and which may be attended with sound and tidal waves depending upon the circumstances of the original impulse. When the wave of compression is passing through a solid stratum, each particle of the earth performs a vibratory movement similar to that made on the passage of a wave of sound, moving forward and returning in an elliptical or a more complicated curve. When the shock reaches the earth's surface the vibration of the particles at any point

may be somewhat to the right or left of the line of propagation from the origin of the impulse, owing to unequal strains or other disturbing causes; but in the main it is simply forward during the first half of the orbit (the first semiphase), and backward during the latter half, and therefore nearly in a straight line. The forward and the return movements when at their maximum velocities are generally almost precisely in a line with the direction of the propagation, and it is at these moments of maximum velocity that the destruction of walls, &c., by the earthquake is accomplished. During the forward movement occurs also the greatest velocity in the upward direction. The downward movement of the earth accompanies the backward or the latter half of the pulse; but the backward movements are generally slower than the forward, and therefore have a less destructive effect. The twisting of isolated blocks, which had by many been ascribed to a circular or vorticose movement of the earth, is in reality, as Mallet shows, the effect of a simple direct stroke acting in connection with the inertia of the body and the friction at its base as a mechanical couple. When the origin of the impulse is vertically beneath the observer, the movement of each particle of the earth about him will be mainly in the vertical direction; when the origin is at a distance, the movement will be more or less inclined to the horizon; and if by a proper seismometer we determine for several places the azimuthal direction and the angle of emergence of the pulse, it becomes possible to fix exactly the position of the origin. The destruction of walls, moving of solid bodies, &c., are therefore due not to the velocity of transit or that with which the shock passes along over the earth's surface, but to the velocity of the movement of each particle of the surface of the earth in its small elliptical orbit. The velocity of translation depends on the elasticity of the rock or earth, but rapidly diminishes in proportion as the rock is discontinuous or non-homogeneous; it is therefore generally different in each direction. The wave of shock or the pulse of compression is reflected and refracted on encountering a new stratum of different elasticity, precisely as in the case of sound. So also phenomena of interference can arise, and it is in such cases that the pulses cease to be rectilinear or elliptical, and become more complicated curves. When the earthquake originates under the bed of the sea, the vertical shock communicated to the waters causes a wave or a swell, often of large extent, that spreads outward in all directions with a velocity varying with the depth of the ocean at the point over which it may be passing, and which on reaching shallow water rushes along as a breaker preceded by a fall or a recession of the water. In earthquakes of this kind, therefore, there may proceed from a single origin (the seismic focus) within the earth a great wave of compression (the wave of shock)

and, accompanying it, a wave of sound; both waves will before they reach the observer be transformed by the influence of discontinuity and non-homogeneity into a complicated mixture of strong and weak shocks and loud and feeble noises. The sea water first affected by the shock will receive and propagate waves of sound, small forced waves of water, and the large swell which ultimately becomes the great earthquake wave, all of which will reach the observer on the land at different moments, depending on their respective velocities. The disturbance having passed through the ocean upward to the atmosphere must communicate to it the three sorts of waves already existing in the water, but of these the sound wave is the only one that is perceived. This completes the entire phenomena of an earthquake so far as relates to the shocks and sounds. When the impulse originates under the land, there is wanting from the preceding enumeration of six classes of waves or pulses only the great sea wave; all the others may be present, but if the shock extends with severity to the shore of a sea, the small forced waves that will arise may be of considerable magnitude, while the vertical stroke that was in the former case expended in producing the great sea wave now expends itself on terrestrial objects. The preceding views, as elaborated by Mallet, and in part adopted by Hopkins in his report of 1847 to the British association, were very generally accepted, but partook somewhat of a hypothetical nature, because of the scarcity of accurate observations of actual earthquakes, till 1862, when Mallet published the details of the methods and results of his investigation of the Neapolitan earthquake of 1857, to the study of which he had devoted much time at the expense of the royal society. In this investigation, the great importance of which as well as its complete success justifies our detailed attention, Mallet has established the science of seismology upon an immutable basis of accurate observation. By using the fissures in buildings, the disturbances of heavy objects, &c., as natural seismometers, and by proper selections of representative cases, he was able, with the mathematical assistance of the Rev. Samuel Houghton, to fix from 177 determinations the position of the seismic focus or origin of the disturbance as being a cavity beneath the village of Caggiora near Potenza. From 26 determinations of the angle of emergence he found the mean depth of the cavity to be  $5\frac{1}{2}$  m. beneath the sea. Lines of equal seismic disturbance being drawn, he showed the earthquake to have desolated a region larger than any of which we have exact knowledge. The refractions and reflections of the wave of shock in encountering various strata were clearly shown. From the number and directions of the sounds and shocks he deduced the general form and position of the focal cavity, and showed that it must have been of the nature of a curved fissure whose height was 3 m., length 9 m., and

thickness very small. The amplitude of the vibrations of the particles at the surface of the earth near the seismic vertical was deduced as 2.5 in. ; at a greater distance it was found to be somewhat greater, and Mallet remarks that it thus becomes evident that the earthquake is itself not an agent capable of directly producing any considerable permanent elevation of the land, but that it occurs along with and as part of a train of circumstances that do occasionally produce such elevations. The velocity with which the shock is propagated along the surface, or the velocity of transit, was found from seven determinations to vary between 989 and 658 ft. per second, depending on the nature of the strata concerned. This agrees well with other determinations made by Mallet in England and Schweitz in Hungary; but the velocities are 300 ft. less than those found by Nöggerath in southern Germany, where however different strata come into consideration, and Mallet has shown that owing to discontinuity and other causes the actual velocity of translation may be so low as one tenth of that which would take place were the rock continuous. These velocities refer to the surface of the ground, and require a slight increase in order to obtain the true velocity normal to the front of the wave. The maximum velocity of the wave particle in its orbit, or the velocity of the shock itself, was determined in 13 cases; the results vary from 9.8 to 21.2 ft. per second, their mean being 12.4 ft., and only three of the determinations materially differ from this. There were strong indications of a diminution of wave velocity with increase of distance from the focus. It is therefore evident that the velocity of the shock that causes the destruction during an earthquake is far less than the rapidity with which it is propagated. It is not necessary to presume that a similar velocity prevails in all other earthquakes; indeed, in the case of the tremendous shock at Riobamba in 1797, Mallet shows that the velocity of the shock must have been about 80 ft. per second, and this is very probably one of the most violent on record. Owing to the imperfect elasticity of the earth, the return movement in the orbit of each particle is not so great or rapid as the forward movement; in two cases Mallet was able to determine the existence of a slight difference of this kind. A definite idea of the severity of the maximum shock experienced during this earthquake may be formed by considering that it was such as would have been given to an obstacle run into by a locomotive moving at the rate of 10 m. per hour. The nature of the fleeting earthquake forces that instantaneously desolate the earth having been thus most successfully investigated by Mallet, the same path has been followed by Oldham in an equally successful and instructive manner in reference to the earthquake of Cachar, India, on Jan. 10, 1869; but the details of this work have as yet been only partially published.—*The Origin of Earthquakes*. If our ideas as to the true nature of

earthquakes have but recently come into some degree of accordance with the truth, still more is this the case with our views as to their ultimate cause and origin. On this difficult subject it might still be hazardous to offer any conjectures, were it not that the many unsuccessful attempts of the past have resulted to a certain degree in limiting our views to one or two causes that are not improbably in continual and effective operation. The theories relative to the origin of earthquakes may be divided into two classes: first, those that relate to the immediate active cause of all classes of earthquake motions; second, those that relate to the origin of the internal heat of the earth. The views of the first class have already been incidentally partially indicated in the preceding section. Considering them chronologically, we come first to the ancient indefinite notion of a blow or concussion somewhere within the earth, which was more definitely explained by Fromondi (1527) and by Travagini (1679). In 1693 Flamsteed suggested that explosions of gas communicated tremblings to the air and thus to the earth; in which view he was followed by Amontons (1703), who invoked heated air as the exploding gas. Lister regarded lightning and earthquakes as the results of the firing of "the inflammable breath of pyrites," *i. e.*, sulphur; and Lémery (1700) considered earthquakes to be due to the explosions of any chemical mixtures containing sulphur and iron. Bouguer also invokes the inflammation and explosion of gases. Stukely (1750) finds their origin in electrical discharges within the earth, in which he is followed by Beccaria, Donati, Percival, and Priestley; and even Humboldt and Poey do not deny the possibility of some connection with electricity. Buffon held that caverns exist in the interior of the earth, and that the falling of their ceilings down upon their floors produced the initial concussions and noises; Humboldt, Darwin, and others, have shown that such caverns may have some connection with earthquakes, though not necessarily in the manner indicated by Buffon. The theory of the Rev. J. Michell (1760) demanded the sudden formation or condensation of aqueous vapor between the crust and the molten interior of the earth, and the passage of waves of this vapor in between the sedimentary strata of the crust, lifting the upper strata in waves like those of a carpet when it is gently shaken on the floor. In 1785 Dolomieu explained how water penetrating into the interior of *Ætna* might flash into steam, producing eruptions and earthquakes; this idea, extended by Bakewell (1813), has since become a favorite with many, and in some shape or other probably has been the prevailing one of the past 30 years. To meet certain very serious objections to Dolomieu's theory, Scrope (in 1825 and 1872) considers that the water is already in place, being confined in cavities within the earth, long before a given earthquake, but that it is exploded into steam by

the heat conducted from some source perhaps at a great horizontal distance; he thinks that no concussion in the proper sense of the word takes place, but that when the expansive power of the water and vapor overcomes the adhesion of the rock and splits it, then the sudden tearing is accompanied by a reaction, giving rise to waves of shock, sound, &c. The idea of the formation of fissures as the result of protracted increasing tension seems also to have been adopted by Hopkins, Darwin, and others. In 1834 Keferstein, and in 1836 Sir John Herschel, independently of each other, advocated certain views that have been more elaborately treated by many geologists, such as Hunt (1858-'72), Sorby (1863), Deville, Naumann, Forbes, and Daubrée. Starting with a suggestion of Scrope and Babbage that the heat slowly conducted from the solid interior of the earth would be concentrated near the surface under the increasing accumulation of sedimentary deposits that are poor conductors of heat, these chemical geologists show that such heat would probably slowly bring about chemical changes, metamorphism, evolution of gases, the transformation of the strata into a pasty mass of lava, and the explosion of the confined water, if such existed or were formed by the chemical changes. In 1854 Zantedeschi maintained that the fluid nucleus of the earth and the exterior thin crust are subject to solar and lunar tides, the crust being flexible like a thin sheet of iron; and that the upward pressure against the crust of a high tide in the interior ocean of lava elevates and cracks the solid strata, causing earthquakes and volcanoes. These hypothetical tides have been rendered quite improbable by the researches of Hopkins and Thomson. Lamont (1862), Varley (1870), and Sumichrast (1871) have connected together the phenomena of terrestrial magnetism and earthquakes, and have expressed the belief that the latter are due to magnetic action. The earlier papers of Mallet (1846 and 1862) made highly probable the general truth of the theory that the sudden expansion of steam under high tension is the immediate cause of the earthquake; he showed that the phenomena of the earthquake of 1857 may be thus explained in a very reasonable manner; but in 1873 he concludes that more causes than one may and probably do produce these concussions, as will be seen in our next section.—The second class of theories of the origin of earthquakes includes those that seek for the source of the internal heat of the globe. Passing by the ancient idea of internal fire, we come to Lémery (1700), Lister, Boyer, Breislak, Sir William Hamilton, Sir Humphry Davy, Daubeny, and many others, who attributed the heat to some form or other of internal chemical changes. Stukely (1750) and his followers sought its origin in electric currents. The nebular hypothesis of Laplace (1780) afforded Poisson, Scrope, Hopkins, Lyell, Phillips, and others, a base for the idea,

now widely accepted, that the present internal heat is but the remnant of that which prevailed when the earth was in its original condition of entire fluidity, and which it has slowly lost by radiation. Finally, when the mathematical investigations of Sir William Thomson had confirmed the idea of Hopkins that the earth must be in general solid, perhaps even to the centre, and when the ideas of permanent internal lakes of lava and of areas of special heat were beginning to be looked upon as too purely hypothetical, Mallet (1873) has with great success undertaken to solve the problem, and his views, covering as they do the whole field of vulcanicity, seem to meet with universal approbation. He shows that the secular cooling of the earth, supposing it to have been once a hot fluid globe, gave rise at first to a thin crust, whose contraction while thin was more rapid than that of the interior, thus causing it to be torn into segments by forces of tension; but that as the crust thickened it became subject to strains of the nature of tangential pressures as soon as the interior began to contract more rapidly than the exterior (the existence of such pressures was first pointed out by Prévost in 1835); the bending and crushing consequent upon these crushing pressures formed the chief mountain chains and ocean beds, as urged by Prévost, Dana, and others; the nucleus shrinking more than the shell, and the latter not being able to resist the strain upon it, it must crush and sink down upon the shrinking nucleus, the crushing being more or less paroxysmal; this crushing is accompanied by an immense evolution of heat, the quantity of which may be calculated by means of the theorems of the mechanical theory of heat, in connection with experiments instituted by Mallet (the heat resulting from crushing is a reality; that which Vose in 1866 suggested as resulting from pressure only cannot exist unless the pressure produce crushing or sudden compression); this heat, acting on the already heated interior, abundantly suffices to melt the adjacent portions thereof, producing lava, or to convert water into the steam that produces both earthquakes and volcanic eruptions. Mallet has made such experiments on the crushing of rocks and such calculations for all the volcanoes of the earth as prove that of the telluric heat known by the observations of the temperature of the earth to be annually dissipated into space, one fourth part is sufficient to account for the annual volcanic energy. He discerns therefore in the secular cooling of the earth and crushing of its shell a true physical cause for the earthquake; the crushing goes on *per saltum*, and is attended with either partial permanent elevations or with heat sufficient to melt rock and produce volcanoes and earthquakes. The function of the earthquake and volcano is thus seen to be preservative and not destructive; these are the instruments by means of which the solid crust of the globe

is kept in a state to follow down after the shrinking nucleus; little by little they accomplish in each locality a work that would otherwise be accomplished by sudden and terrible paroxysms overspreading the whole earth.—*Earthquake-proof Buildings.* The views of Mallet as to the nature of the movement of the surface of the earth during an earthquake shock have enabled him to define certain principles according to which buildings may be constructed so that they shall be able to resist any shock that is likely to visit them. These principles have been already applied by Mallet and Stevenson in the construction of light-houses for the Japanese government, and by Mr. W. Lloyd in the construction of the new custom house at Valparaiso.

**EARTHS,** the oxides of the metals aluminum, glucinum, thorium, zirconium, lanthanum, erbium, and yttrium, called alumina, glucina, &c. They are often called the earths proper, to distinguish them from the alkaline earths, baryta, strontia, lime, and magnesia, the oxides of the metals barium, strontium, calcium, and magnesium. Before the decomposition of some of them by Sir Humphry Davy they were thought to be elements. Silica was formerly regarded as an earth; but on account of its forming definite compounds with the earths in which they act the part of bases, it must be classed as an acid. The earths generally exist in nature in combination with silica; although in the varieties of corundum, such as the gems sapphire, ruby, oriental topaz, and oriental amethyst, alumina exists principally as oxide, the Indian sapphire having the composition  $Al_2O_3$ , 97.5 per cent.; magnesia, 1.9; silica, .8 per cent.; and the Indian ruby containing barely more than 1 per cent. of silica. In feldspar alumina is found combined with silica, sometimes with silicate of soda, but more frequently with silicate of potash. The gem hyacinth is composed of silicate of zircon. The silicate of glucina is found in the beryl and erbium. Associated yttrium is found, combined with silica, in the mineral gadolinite.

**EARTH WORM** (*Lumbricus terrestris*, Linn.), an articulate animal belonging to the abbranchiate division of the class of annelids. (See ANNELIDA.) This well known worm has a long, cylindrical, contractile body, divided into many apparent rings (sometimes 150) by transverse wrinklens; the internal surface of the muscular envelope sends off annular septa, dividing the cavity of the body into as many chambers as there are segments, the partitions having openings which allow the passage of the contents of the general cavity from one chamber to the others. Each segment is provided with *setæ* or bristles, beginning at the 14th ring from the head, four on each side, united in pairs, forming eight longitudinal rows, of which four are lateral and four inferior; they are short and rough, and are used as fulcra during creeping or climbing in the

ground. The sense of touch is very acute, as is shown by the quickness with which they retire into the ground when touched, or at the jar produced by an approaching footstep; the sense is believed to be most acute toward the head, especially in the first segment. The eyes are wanting. The mouth is near the anterior extremity of the body, without teeth, with two somewhat prominent lips; the pharynx is simple, short, and muscular, the œsophagus narrow, the stomach very muscular, and the intestine short, straight, constricted by the muscular septa, and opening at the posterior extremity of the body. The blood is red, and the circulation is complete and closed; the several pairs of simple, transverse canals, situated above the stomach, whose pulsations may be distinctly seen, may be considered the heart. The dorsal vessel lies upon the intestinal canal enveloped in the hepatic tissue. The blood, though red, is quite different from that of the vertebrates; according to Siebold, it contains colorless, spherical, unequal-sized granular globules; these, Quatrefages says, are not part of the blood, but belong to the fluid of the general cavity; the latter maintains that the coloring matter is in simple solution. There is no apparent external organ of respiration, and the peculiar canals in the abdominal

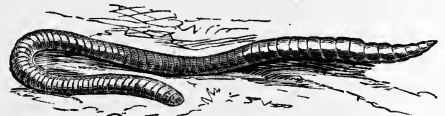

Earth Worm (*Lumbricus terrestris*).

cavity are regarded by some as internal branchiæ or aquiferous vessels. The structure of these organs is little understood; but in all genera of the division there are at the commencement of the intestine very tortuous canals, opening generally on the ventral surface; these canals are lined with ciliæ, which have an undulatory movement always in one direction; they never contain air, according to Siebold, but circulate an aqueous respiratory fluid by means of the ciliæ; even the terrestrial earth worms can live only in damp earth, from which they obtain the necessary aqueous fluid. In the *lumbricus* these canals are surrounded by a distinct vascular network; they appear to end in loops, and their external orifices have not been satisfactorily ascertained. The most probable opinion is that the respiration is carried on principally by the general integument, and partly by the vascular system on the walls of the intestine; the ciliated canals described by Siebold are believed by Quatrefages to be organs for the secretion of the mucus which invests the body; but Dr. Williams, in his "Report on the British Annelida" (1851), considers them as utero-ovaria. The *lumbrici* reproduce by sexual organs; their eggs are spherical and present nothing



remarkable; the sexes are united in the same individual. During the breeding season, from six to nine of the segments (from the 26th to the 37th, as generally described) are developed into a kind of collar, nearly surrounding the body, by which these animals seize each other during coition; its component glandular follicles secrete a whitish viscid fluid, probably used for the formation of their cocoons or egg cases. According to Dufour, these cocoons have a long narrow neck, each, in the largest species, containing from one to six eggs; the statement of Montègre that the young are born alive seems to be confirmed by the observations of Dr. Williams, who says that they escape from the egg before leaving the body of the parent. It seems certain from the experiments of Dufour (*Annales des sciences naturelles*, t. v. p. 17, and t. xiv. p. 216, 1st series) that the earth worm reproduces by means of eggs; he describes them as an inch in length, of a corneo-membraneous consistence, deposited in the earth at a depth of from 6 in. to 6 ft., in localities where the soil is neither inundated nor too dry, isolated, and each egg containing one or two young. Earth worms live in moist earth, in which they make galleries in all directions, swallowing the earth as they proceed; their food is principally soft and decaying vegetables, as may be proved by any one who chooses to watch a garden walk by the light of a lantern on a damp evening, when they may be seen creeping out of their holes, elongating their first tactile segment, feeling in all directions for food, and, seizing upon any suitable substance that presents itself with their projected proboscis, retiring backward into the ground; their constant presence in situations where there is decaying vegetable matter proves that their food is principally derived from such substances; they also, as Montègre observed, feed on animal matters; it seems more reasonable to believe, with De Blainville, that they swallow earth for the purpose of making progress in their galleries, than that they do this to extract humus or any other nutritious substance from it. They seek each other chiefly at night and in the latter part of spring, though some species have been noticed together at all times of the day, and during all the warm months; it is well known that they are most abundant on the surface of the ground during and after nocturnal rains. It has long been believed that this animal possesses a remarkable power of reproducing parts lost by accident or design, even to the extent of forming perfect individuals from separated portions; the experiments of Dugès prove that very important parts may be reproduced, and it may easily be believed that in a worm divided into two, the anterior portion might produce an anus by the simple contraction of the wound; but that the posterior portion should be able to reproduce cerebral ganglia, mouth, stomach, cardiac and sexual organs, cannot be admitted; the anterior may survive a long time, but the

posterior division gradually dries up and dies. —Though occasionally marring the beauty of the garden walks by little hillocks of earth, they not only do not injure vegetation, but are useful in permitting air and water to penetrate the ground through the channels which they pierce in every direction, manuring the fields, and throwing up fine dirt around the roots of grass; a field in which no worms exist can be safely put down as of little value to the agriculturist; they are most active in spring, when most needed, and retire during winter deep into the ground; according to Mr. Darwin, they perform under ground that which the plough and the spade do on the surface, and have covered a field manured with marl, in the course of 80 years, with a bed of earth 13 inches thick. Worms also furnish food for birds, moles, frogs, and other small animals, and are used as bait for many kinds of fish. The rapid ascent and descent of worms in the ground are easily understood from the action of their numerous setæ; they have often been seen high up on perpendicular surfaces, and in situations which they could not have reached without climbing perpendicularly. In their movements they display great muscular force, each seta being moved by its appropriate system of muscles, and being capable of penetrating a deal board; in ascending perpendicular surfaces of glass or other impenetrable material, they must retain their hold by means of the tenacious mucus with which their skin is covered. —There is no question that many species have been confounded under *L. terrestris* (Linn.). The largest European species is called *L. gigas*, and is 18 in. long, and as large as the little finger; other common and smaller species are *L. anatomicus* and *L. trapezoides*. Whether all the American species are distinct has not been sufficiently demonstrated. Those who wish to pursue this subject into its details are referred to the writings of Dufour, Dugès, Milne-Edwards, Blanchard, and especially Quatrefages in the *Annales des sciences naturelles* since 1828; to the article "Annelids," in the "Cyclopædia of Anatomy and Physiology;" to the report of Dr. Williams, above quoted; and to Siebold's "Comparative Anatomy."

**EAR TRUMPET**, an instrument intended to aid the hearing of persons partially deaf, although sometimes used by ordinary persons to intensify distant sounds. We have no means of ascertaining at what period or by whom ear trumpets were invented. The practice of putting the hand to the ear in a trumpet shape probably first suggested it, and from occasional allusions to the use of the trumpet in old writers it would seem to have been of very early origin. The earliest form of which we have any knowledge was a rude imitation on an exaggerated scale of the form of the external ear; but as this was found inconvenient from the difficulty of retaining it in place, a form more nearly resembling a speaking trumpet was substituted. This was modified by bend-

ing the tube and applying the mouth, turned forward and given an elliptical form, close against the ear. Another modification was a flat tube passing over the head and applied to each ear, while in front and immediately over the forehead was an opening to receive the sound. One inventor, having observed that in listening intently people opened their mouths, contrived a sort of plectrum or vibrating body to be held between the teeth, and thus to convey sounds by the Eustachian tube. After the introduction of caoutchouc and gutta percha into the arts, a long tube of one or other of these materials, with a bell-shaped trumpet at the end, took the place of the metallic trumpet, and for many purposes is very convenient. In England in some of the churches pews are constructed with tubes to conduct the sound, opening in convenient positions for the ear of the listener. Among the more recent inventions for facilitating hearing are the auricle, a small tube of silver with a semi-globular expansion, intended to be inserted into the meatus of the ear; and the tympanum, a small thin disk of rubber, having a silver wire passing through it to transmit the sound wave. In a few cases the latter has been of considerable service. In total deafness such means are of no advantage.

**EARWIG**, an orthopterous insect, of the family *cursoria* or runners, which also includes the cockroach; it belongs to the genus *forficula* (Linn.). All the six feet are formed for running; the wings are four, the upper pair very short, coriaceous like the elytra of coleoptera, without veins, enclosing the under wings, which are folded both longitudinally and transversely; the mouth is formed for mastication; the body is long and somewhat flattened, and armed at the hinder end with a pair of curved blades shutting like scissors or nippers; there are three joints to the tarsus; the antennæ are filiform. These insects undergo a partial metamorphosis. They seem to form the connecting link between coleoptera and orthoptera, resembling the former in their elytra, and the latter in the shape of the wings and mouth, and the metamorphosis; for these reasons most English entomologists adopt for them the order *dermaptera* of Mr. Kirby and Dr. Leach, considering them coleoptera with



Earwig.—1. Forficula. 2. Lithobius.

the metamorphosis and caudal appendages of orthoptera. They are common in moist earth, under stones, in decayed wood, and in similar damp and dark places; they are considered in Europe injurious to peaches, pears, apples, to

greenhouse plants, and to pinks, dahlias, and other favorites of the flower garden. The full-grown insect, including its caudal forceps, is not quite an inch long, and its width is one sixth of an inch; the color is light brown. Being nocturnal, they creep in the daytime into any crevice or hole, and this has given rise to the popular belief that they enter the human ear; they might attempt this, but the waxy bitter secretion of the ear would probably prevent their entrance; there are no well authenticated instances of their doing this, and no harm could result if they did, as the drum of the ear would arrest them, and a drop or two of oil would soon destroy them by stopping up their respiratory tracheæ. The common way of catching them in England is by hanging up any convenient vessel or tube for them to crawl into in the morning, from which they are shaken and killed. In the larvæ there are no wings or elytra, but the skin is changed several times; the nymph differs little from the perfect insect; in both these conditions they are voracious, even devouring each other. In this country there are several species, rather uncommon, and never injurious to vegetation.—The many-footed creeping animal erroneously called earwig in America (genus *lithobius*) is not an insect, but a myriapodous crustacean, equally innocent of entering the human ear.

**EASDALE**, or *Elsdale*, an island on the W. coast of Argyleshire, Scotland, in the frith of Lorn, nearly adjoining the island of Seil, about  $\frac{1}{2}$  m. long and of nearly the same width, noted for its slate quarries, which have been worked for nearly two centuries, and furnish annually more than 4,000,000 slates. The island consists entirely of slate, and has been so much cut away that a large part of it is now even with or below the level of the sea.

**EASEMENT**, a privilege which the owner of one tenement, called the dominant tenement, has in respect to another, called the servient tenement, by which he may require the owner of the latter to permit something to be done thereon, or to refrain from doing something, which otherwise as owner he would be entitled to do. It must be defined and limited in extent, and it must in some way be for the benefit of the dominant tenement, and not for some general benefit to the owner. Among the principal easements are rights of way, the right to carry water or to obtain light or air over the adjoining lands, the right to support of land or buildings by adjacent land or buildings, the right to have party walls and fences kept in repair, &c. In general, they must be created by deed or established by prescription, though every man has a natural right to the support of his land by the adjacent land of another, but not to the support of the artificial structures he may rear upon the land. Easements are lost by release, by abandonment, or by the dominant and servient tenements becoming united in the same ownership. Public rights

over the lands of private individuals, for purposes of travel and the like, are often spoken of as public easements.

**EAST** (Anglo-Saxon, *East*; the corresponding word in many other languages having a similar etymological significance), the quarter in which the heavenly bodies rise. Due east is the direction toward the east precisely at right angles to each meridian line; the reverse direction is due west. An object is said to bear due east when it is seen exactly in this direction, but it is said to be due east when it is on the same parallel of latitude as the observer. An object that is due east will in northern latitudes bear N. of E., unless it be very near the observer, because a line perpendicular to a meridian in any latitude, if continued in one direction as a great circle, would depart from the parallel of latitude and intersect the equator at a distance of one fourth of a circle. A column of smoke, for example, over New York city, could it be seen at Nauvoo, would bear  $5\frac{3}{4}^{\circ}$  N. of E., and smoke rising from Nauvoo would bear from New York  $5\frac{3}{4}^{\circ}$  N. of W. The bearing is the direction in which a great circle from the observer through the object starts from the observer; while the course or actual direction is the direction of a line to the object cutting every meridian at the same angle.

**EAST BATON ROUGE**, a S. E. parish of Louisiana, bounded E. by the Amite river and W. by the Mississippi; area, about 450 sq. m.; pop. in 1870, 17,816, of whom 11,343 were colored. The surface is level in the north and gently undulating in the south; the soil is moderately fertile. There are extensive forests of live oak, cypress, and magnolia. The chief productions in 1870 were 185,133 bushels of Indian corn, 3,163 of Irish and 32,075 of sweet potatoes, 8,967 bales of cotton, 833 hogsheds of sugar, and 59,497 gallons of molasses. There were 1,296 horses, 1,275 mules and asses, 3,203 milch cows, 5,936 other cattle, 3,470 sheep, and 7,819 swine; 1 manufactory of agricultural implements, 1 of boots and shoes, 2 of carriages, 1 of barrels and casks, 1 of cotton goods, 1 of gas, 10 of molasses and sugar, 1 of woollens, and 1 sawmill. Capital, Baton Rouge.

**EAST BIRMINGHAM**, Pa. See BIRMINGHAM.

**EASTBURN**. I. James Wallis, an American author, born in England in 1797, died at sea, Dec. 2, 1819. He graduated at Columbia college, New York, in 1816, and studied theology under Bishop Griswold at Bristol, R. I., with a view of taking orders in the Protestant Episcopal church. While thus employed he undertook a new metrical version of the Psalms, which he did not live to complete. In conjunction with Robert C. Sands he published in 1818 "Yamoyden," a romantic poem founded on the history of King Philip, the sachem of the Pequots. He also wrote several fugitive poems, some of which are very gracefully versified. In 1818 he was ordained, and was about to take charge of a parish in Accomac, Va. He sailed for Santa Cruz to restore his health,

but died a few days after embarking. II. **Manton**, an American bishop, brother of the preceding, born in Leeds, England, Feb. 9, 1801, died in Boston, Sept. 11, 1872. He came to America with his parents while a child, graduated at Columbia college in 1817, studied at the Episcopal theological seminary in New York, and was ordained deacon in 1822, and priest in 1825. He was for five years assistant minister in Christ church, and in 1827 became rector of the church of the Ascension, New York. At the close of 1842 he was consecrated assistant bishop of the diocese of Massachusetts; and in February, 1843, on the death of Bishop Griswold, he became bishop of the diocese. His principal works were: "Four Lectures on Hebrew, Latin, and English Poetry" (1825); two essays in a volume entitled "Essays and Dissertations in Biblical Literature" (1829); "Lectures on the Epistle to the Philippians" (1833); "Oration on the Semi-centennial Anniversary of Columbia College" (1837); and many sermons and pastoral charges. He also edited, with notes, "Thornton's Family Prayers" (1836). He bequeathed his property to the domestic missions in Massachusetts, to the Episcopal theological seminary in Massachusetts, to the American Bible society, and for other benevolent objects.

**EAST BRIDGEWATER**. See BRIDGEWATER.

**EASTER** (Germ. *Ostern*, old Saxon *oster*, *osten*, rising), the Christian passover and festival of the resurrection of Christ. The English name is probably derived from that of the Teutonic goddess of spring, Ostera or Eostre, whose festival occurred about the same time of the year as the celebration of Easter. The Hebrew-Greek word *πάσχα* has passed into the name given to this feast by most Christian nations. The French call it *Pâques*, the Scotch *Pasch*, the Dutch *Paschen*, the Danes *Paaske*, and the Swedes *Påsk*. St. Paul calls Christ "our Pasch;" and both the eastern and western churches from the beginning distinguished a twofold event in the Easter commemoration, the slaying of "the Lamb of God" and his resurrection; hence the terms in their liturgies, *pascha crucifixionis* and *pascha resurrectionis*. And the distinction between the day on which Christ died and that on which he rose again had not a little to do with the Easter controversy in the early church, originating in a difference of custom with regard to the day of the week and the day of the month on which Easter should be celebrated. As the Christians held that Christ, the true paschal lamb, had been slain on the very day when the Jews in celebration of their passover immolated the figurative lamb, so, both in the West and in the East, those who believed the Christian passover to be a commemoration of Christ's death adhered to the custom of holding the Easter festivity on the day prescribed for the Jewish pasch. Now, as the Jews celebrated their passover on the 14th day of the first month, that is to say,

the lunar month of which the 14th day either falls on or next follows the day of the vernal equinox, all Christians who persisted in following this custom in the celebration of Easter came to be called quartodecimans or "fourteenth-day men," or, still more opprobriously, Judaizing Christians. The great majority of Christian churches, attaching most importance to the day of Christ's resurrection, which was the first day of the week (hence called the Lord's day, our Sunday), held to Easter's being celebrated on that day, and on the Sunday which followed the 14th day of the moon of March, the day on which Christ suffered. This question, one of custom and local discipline in the beginning, had given so much trouble that about 158 Polycarp, disciple of St. John the Evangelist and bishop of Smyrna, went to Rome to consult with Pope Anicetus on the means of healing the difference. In the council held in Rome on this occasion, the western or present manner of celebrating Easter was affirmed; but Polycarp departed with the full friendship of the pope and in the communion of the church of Rome. Gradually, however, the question of the Easter celebration from one of discipline became one of dogma. In 182 a priest called Blastus made himself very obnoxious in Rome by endeavoring to have the Jewish rule of celebrating Easter on the 14th day of the moon of March adopted as a rule of faith. The discussion throughout the Christian world had become so angry that Polycrates, bishop of Ephesus, appealed to Victor, bishop of Rome, asking to have this matter decided once and for all. Councils were at once assembled in Gaul, Pontus, Osroene, Achaia, and other countries, as well as in Rome. The result was a decision fixing the feast of Easter, or the resurrection, on the Sunday immediately following the 14th day of the March moon. Polycrates refused to acquiesce in this decision, because it involved an abandonment of the customs of his fathers. The decree of excommunication pronounced against the quartodecimans by the council of Rome was held in abeyance, at the prayer of Irenæus of Lyons; and a schism was thus averted. After this the contending parties agreed to maintain their respective customs and practices in this respect without censuring one another. Constantine had the subject brought before the council of Nice, in 325. The question was fully discussed, and finally settled for the whole church by adopting the rule which makes Easter day to be always the first Sunday after the full moon which happens upon or next after March 21; and if the full moon happen on a Sunday, Easter day is the Sunday after. By this arrangement Easter may come as early as March 22, or as late as April 25. In France the year began with Easter from the 12th century till 1564, for which year Charles IX. fixed Jan. 1 as the first day.—This sacred festival has been termed the queen of festivals; it has been observed from the very beginning,

and is celebrated in every part of the Christian world with great solemnity and devotion. Formerly the churches were ornamented with large wax candles, and the Christians saluted each other with a kiss and the words "Christ is risen," to which the response was made, "He is risen indeed." This custom is still retained in the Greek church, particularly in Russia. The day before Easter Sunday, or Holy Saturday, has ever been set apart as a day for especially solemnizing baptism. Courts of justice were closed, alms were distributed, slaves were freed, and the people gave themselves up to enjoyment and feasting. In nearly all Christian countries the recurrence of Easter has been celebrated with various ceremonies and popular sports and observances. Among the best known is the custom of making presents of colored eggs, called pasch or pace eggs, which were often elaborately ornamented; and in a royal roll of the time of Edward I., preserved in the tower, appears an entry of 18*d.* for 400 eggs to be used for this purpose. Colored eggs were used by children at Easter in a sort of game which consists in testing the strength of the egg shells, and this practice is still continued in most Christian countries. In some parts of Ireland the legend is current that the sun dances in the sky on Easter Sunday morning. This was once a prevailing superstition in England also, which Sir Thomas Browne, in his "Inquiry into Vulgar Errors," thought it not superfluous to declare unfounded. The game of ball was a favorite Easter sport, in which municipal corporations formerly engaged with due parade and dignity; and at Bury St. Edmund's within a few years the game was kept up with great spirit by twelve old women. In the northern counties of England the men parade the streets on Easter Sunday, and claim the privilege of lifting every woman three times from the ground, receiving in payment a kiss or a silver sixpence. The same is done by the women to the men on the next day.

**EASTER ISLAND**, an island in the eastern part of the Pacific, lat. 27° 6' S., lon. 109° 17' W., distant about 2,300 m. from the coast of South America. From its solitary position it has been but seldom visited. It was discovered in 1722 by Roggweeen, a Dutch navigator, and was visited in 1774 and described by Cook. It is about 11 m. long and 6 broad, and contains three extinct volcanoes of large size, rising to the height of 1,200 ft. above the sea. The land in the valleys is fertile and well cultivated; but the island is deficient in water. The natives, who number about 1,000, are tall and robust, with regular features and dark complexion. They belong to the Polynesian race, and until lately were fiercely hostile to the whites. In 1865 some French missionaries landed among them, and, though at first treated with great rudeness, finally succeeded in converting them to Christianity, which is now professed by the entire population.—The remarkable feature of the island is that it con-

tains several hundred gigantic stone statues, tolerably well chiselled. The largest of these are 40 ft. high, and measure 9 ft. across the shoulders. Many of them stand in the crater of the great volcano, while others are scattered about the island, generally prostrate. They were cut from the common rock of the island, and many unfinished statues are yet to be seen in the quarries. Nothing is known of the origin of these statues. They were certainly not made by the present race of inhabitants, who have no tools adequate to their sculpture, nor any means of moving such huge masses. The native traditions about them are puerile, and seem to ascribe them to a supernatural origin. The conjecture has recently been advanced that the island is the remnant of a submerged continent, and that the statues were made by an extinct people who worshipped their idols in high places, and to whom the craters of volcanoes were peculiarly sacred.

**EASTERN EMPIRE.** See **BYZANTINE EMPIRE.**

**EAST FELICIANA,** a S. E. parish of Louisiana, bounded N. by Mississippi, E. by the Amite river, S. W. by the Mississippi, and W. by Thompson's creek; area, about 500 sq. m.; pop. in 1870, 13,499, of whom 9,393 were colored. The Clinton and Port Hudson railroad extends from the capital to the Mississippi river. The surface is moderately uneven, and the soil is well watered, fertile, and easily tilled. There are forests of pine, oak, and bay. The chief productions in 1870 were 167,262 bushels of Indian corn, 26,263 of sweet potatoes, 10,252 bales of cotton, and 5,900 lbs. of rice. There were 1,147 horses, 890 mules and asses, 2,155 milch cows, 3,954 other cattle, 2,284 sheep, and 5,637 swine. Capital, Clinton.

**EAST INDIA COMPANIES,** associations formed to conduct trade between Europe and the Indies. The overland trade, in which the Italian republics were foremost, was terminated by the Turkish conquest of Constantinople and Egypt. The necessity of a new route to India then became the problem of western Europe, and Vasco da Gama rounded the Cape of Good Hope and reached the Malabar coast in 1498. The Portuguese then established themselves in India, and for nearly a century monopolized its trade. Portugal being united with Spain in 1580 and its ports closed to British vessels, the English bought their Indian supplies of the Dutch. But when on the revolt of the Netherlands Dutch vessels also were excluded from the port of Lisbon, both Dutch and English established direct trade with the Indies. In 1587 a charter was granted to a Portuguese company, in consideration of an annual tribute. On the breaking out of the war between England, Holland, and Spain, which struck a disastrous blow at the India trade, the Portuguese company became unable to pay its annual tribute to the government, and was abolished in 1640. In 1595 a "Company for Remote Parts" was formed at Amsterdam, which in 1602, having been united with other

companies, received a charter from the states general conferring on them the exclusive privilege of trade to the East Indies for 21 years, with the necessary civil and military powers. They began with a capital of 6,500,000 guilders, and in 20 years their dividends amounted to 30,000,000 guilders, besides vast amounts of property in colonies, fortifications, and vessels. The charter was extended to 1644; Batavia was founded; the commerce with Japan, which returned silver and copper for commodities, was extended; in 1641 Malacca, capital of the then neglected Portuguese East India possessions, was acquired by the Dutch; and from 34 to 41 freighted vessels were sent out annually, of which from 25 to 34 returned loaded. Yet so rapidly did the English and French commerce increase during these years, that in 1644 the Dutch East India company could scarcely command the 1,600,000 guilders required as a subsidy to the government, on again renewing its charter for 21 years. The peace of Westphalia, which secured the independence of the republic of the United Provinces, once more gave the company life. In 1665 the charter was with much opposition renewed till 1700. At this time the company held the principal seats of commerce in Ceylon, Sumatra, Java, Borneo, and in fact throughout the Indian archipelago, and had large colonies in South Africa. They commanded the trade with Pegu, Siam, Tonquin, Japan, the Banda and Molucca isles, Amboyna, &c. Batavia was then in all its glory, and the straits of Sunda on which it is situated had become, instead of those of Malacca, the channel to the further Indies. The charter was renewed in 1701, in 1741, and in 1776, the last time for 30 years, and on condition of paying down 2,000,000 guilders, with 360,000 annually. Turning their hands against every one in the East, and seeking, by oppression of natives, exclusion of Europeans, and the forced production of some spices with prohibition of the cultivation of others, to rule the markets of the world and to extend and consolidate their dominion and wealth, the company was yet so exhausted by war with England and political expenses, that in 1781 the states general were obliged to assist it with a loan. In the first French revolution it lost nearly all its possessions. The establishment of the Batavian republic in 1795 terminated its existence, and the affairs of the company passed into the hands of the government. A new company was established in 1824, called the *Handel Maatschappij* or trading association. This company became the agent for the sale of the government produce in Europe, and the carrier of this produce, and farmed some branches of the public revenue of Java and the other Dutch East India colonies.—A French East India company, founded in 1664 by Colbert, was broken up in 1770.—A Danish East India company, founded in 1618, was dissolved in 1634; it was reconstituted in 1670, and again dissolved in 1729. A new company, formed

in 1732 under the name of the Danish Asiatic company, was prosperous during the 18th century, but afterward declined. — The English endeavored to open commercial intercourse with India as early as 1553, during the reign of Edward VI., but without success. In 1599 a company of London merchants was formed, representing a capital of £30,133, which received a charter from Queen Elizabeth, Dec. 31, 1600, under the title of "The Governor and Company of Merchants of London trading with the East Indies." The charter was for 15 years, and granted the exclusive right of trading to all countries from the cape of Good Hope eastward to the straits of Magellan, excepting those which were possessed by friendly European powers. The first governor was Thomas Smythe, who was assisted by 24 directors named in the charter, which empowered them to elect a governor and directors and other office-bearers; to make by-laws for their government; to inflict punishments, corporal or pecuniary, on those in their employ, provided such punishments be within the laws of Great Britain; to export all goods duty free for four years, and to export foreign coins as bullion to the amount of £30,000 a year, £6,000 of the same being previously recoined at the mint; with the proviso that they must import within six months from the conclusion of every voyage after the first an amount of specie equal to that before exported. It was also provided that should the company not be found to the public advantage, its charter might be cancelled after two years' notice. The first expedition to India sailed under command of Capt. Lancaster, Feb. 15, 1601, from Torbay. It consisted of five ships, varying in size from 130 to 600 tons, having cargoes of bullion, iron, tin, broadcloths, cutlery, glass, &c. The entire venture, ships and all, was valued, at £69,091. It arrived at Acheen, Sumatra, June 5, 1602. Lancaster made treaties with the kings of Acheen and Bantam, and returned to the Downs Sept. 11, 1603, with cargoes of pepper and other produce. For several years the expeditions were not increased in size or value, but were generally fortunate in their results. In 1607 Capt. Hawkins was sent out to establish commercial intercourse with the dominions of the Great Mogul, but his mission proved of no avail. In 1612 Capt. Beal obtained from the court at Delhi several important privileges, among which was that of establishing a factory at Surat, which city continued to be the chief British station in India until the organization of Bombay. Factories were depots for goods, fortified, to protect the lives and property of resident representatives of the company. In 1613 the capital of the company was united; the largest stockholders took the management of affairs, and these were so prosperous that in four years the shares of the company rose to the value of 203 per cent., while its factories were extended to Java, Sumatra, Borneo, the Banda islands, Celebes, Malacca, Siam, the Coromandel and

Malabar coasts, but chiefly to the dominions of the Great Mogul, whose favor the company had finally secured. From the beginning of the company's trade to July, 1620, it had sent 79 ships to India, of which 34 had come safely home richly laden, 4 had been worn out in India, and 20 had been lost—2 by careening, 6 by sea perils, and 12 captured by the Dutch. At that time (1620) the capital of the company in ships, goods in India, &c., amounted to £400,000; it had exported from England to India the value of £840,376; had imported what cost £356,288 in India, which brought £1,914,600 in England; and finally quarrels with the Dutch, their most energetic rivals, had occasioned losses to the amount of £84,088. In 1616 a new stock subscription had been opened, and £1,629,040 were raised. But in 1627 complaints were made of abuses and bad management; during the reign of the Stuarts there was much murmuring against the monopoly, and Charles I. in 1635 gave to Sir William Courten and several private individuals the right to trade to India. In 1645 permission was given by the natives to the company to build Fort St. George at Madras. In 1655 Cromwell vainly attempted to make the East India trade free. In 1657 he renewed the company's charter, which was confirmed by Charles II. in 1661, who at the same time conferred on it authority to make peace or war with any power not of the Christian religion; to establish fortifications, garrisons, and colonies; to export ammunition and stores to its settlements duty free; to exercise civil and criminal jurisdiction in its settlements according to English law; and to seize and send to England all Englishmen found trading on their private account. In 1667-'8 the tea trade was begun, a branch of commerce which in a few years proved to be of vast importance to the company. In 1669 the island of Bombay was granted to the company by Charles II., who had received it as part of the marriage portion of the princess Catharine of Portugal. In 1676 a factory was established on the Hoogly in Bengal, which led to the foundation of Calcutta; and other factories were shortly started in that region. In 1677 the company received a renewal of its charter, with indemnity for past misuses, and permission to establish a mint at Bombay. In 1681, by a report of the governor, the company had 35 ships, of from 100 to 700 tons, trading between India and England, or coastwise in India; and the exports from England of lead, tin, cloth, stuffs, &c., amounted to from £60,000 to £70,000 a year. The trade was astonishingly small; the affairs of the company were not prosperous, and in 1688 the validity of its charter was questioned, but in 1693, after a heavy struggle, it was renewed. In 1694 a vote of the house of commons threw open the trade to all England. In 1698 a new company received a charter, conferring much the same privileges as those of the old one, for the consideration of a loan of £2,000,000 to the

state. The two companies were united in 1702 under the title of "The United Company of Merchants trading to the East Indies." They advanced a further sum to the state, making in all a loan of £3,200,000, at 3 per cent., in consideration of which their charter was extended until the expiration of a notice of three years, which could not be given sooner than March, 1726, nor until the money borrowed by government should be repaid. The act ratifying this was passed in 1708. By it the local affairs of the company were intrusted to the three councils of Madras, Bombay, and Calcutta, while the general direction was retained in England. Meanwhile, in 1698, a grant of Calcutta and two adjoining villages had been acquired, with the right of jurisdiction over the inhabitants, and leave to erect fortifications, which was immediately done; and in 1715 this jurisdiction was largely extended by grant from the emperor Ferokshere. In 1701 an act prohibited the importation into England of manufactured Indian goods. In 1732 the renewal of the charter was obtained with much difficulty; and in 1744 the company bought its extension to 1780 by a loan of £1,000,000 at 3 per cent. The territorial conquests of the company were inaugurated by the expulsion, in 1749, and ultimate protection of the rajah of Tanjore, he making some concessions of territory on each occasion of the British exercise of protection. In 1757 they deposed Surajah Dowlah, nabob of Bengal, gaining thereby several large and rich provinces. In 1761 the defeat of the French left the English free to pursue their schemes of aggrandizement in India. In 1792 Tippoo Sahib was compelled by Cornwallis to give up half his dominions, and £3,500,000 in bullion. In 1799 Seringapatam was taken, Tippoo slain, and some more territory annexed. Subsequently, by war with the Pindarees, with Burmah, Nepaul, and the Afghans, and by judicious protection, interference, and annexation, the company mastered the whole of Hindostan, with small exceptions. The sudden increase of territory and power in India threw everything into confusion. Corruption reigned everywhere. The revenues fell short of expenses, and in 1772 the company, notwithstanding its immense possessions and privileges, was obliged to raise a loan of £6,000,000 from the bank of England, and of £1,400,000 from government for current expenses. In 1773 reform was called for, but was only incompletely effected. In 1781 the privileges of the company were extended to 1791, with three years' notice; the dividend on its stock was fixed at 8 per cent.; £400,000 was to be paid as an annual subsidy to the government, and three fourths of the surplus revenue was to go to the government, one fourth to the company's use. Yet in 1780 the East India trade formed only  $\frac{1}{3}$  part of the entire foreign trade of the empire. In 1783 the company was again so involved, on account

of wars, &c., as to be unable to pay the subsidy. In the following year, on the proposition of Mr. Pitt, a board of control was appointed, consisting of such members of the British privy council as the sovereign of England chose to appoint, the two principal secretaries of state and the chancellor of the exchequer being three of the members. The president was usually a cabinet minister. In 1793 the charter was prolonged to 1814. From that date the charter was again prolonged 20 years, but the trade to India was substantially thrown open, though the monopoly of the trade to China was continued, and did not cease till 1834. Parliament in 1833 granted a new charter, by which—1, the company ceased to be a trading association; 2, it was continued in the government of India until 1854, subject to the authority of the board of control; 3, India was thrown open to the independent enterprise of British subjects; 4, all the property, real and personal, in possession of the company on April 22, 1834, was vested in the crown, and was to be held and managed by the company in trust for the crown, the stockholders being assured by government an annual dividend of  $10\frac{1}{2}$  per cent. on the stock; 5, of the treasure of the company, valued in 1834 at £21,103,000, £2,000,000 were formed into a sinking fund, with the proceeds of which, in or after 1874, to buy out the stockholders at 200 per cent. valuation, £8,423,000 were consumed in the payment of the company's debts, and the balance was appropriated to various improvements in India; 6, the stock might be bought in by parliament at the rate of £200 for £100 at any time after 1874, with the further condition that if at any time after 1854 the company were deprived by parliament of the government of India, stockholders might demand of parliament to purchase their stock, after three years' notice given. When in 1854 the last charter of the company expired, it was determined by act of parliament to renew it, but not for any given time.—The capital stock, originally £2,000,000, had been increased at various times, till in 1793 it amounted to £6,000,000. At this it remained by law. This stock was owned in 1835 by 3,579 persons. As it was marketable, of course the number of stockholders continually changed. The ownership of stock to the amount of £1,000 (worth in 1835 £2,540) gave the privilege of one vote at the stockholders' meetings. The owner of £3,000 had two votes, of £6,000 three, of £10,000 and over, four. Women as well as men, and foreigners as well as Britons, if owning the requisite amount of stock, and present in London in person or by proxy, had the privilege of debating and voting. Stock must, however, have been held 12 months before the owner was entitled to a vote. In 1852 there were 2,583 voters, of whom 372 were women, 20 were peers of the realm, 10 members of parliament, 50 ex-directors, 86 clergymen, 19 physicians, 222 army officers, and 28

naval officers. Before 1836 the majority of the stockholders were merchants and bankers, but the changes in the constitution, which extinguished the company as a trading association, caused a material decrease of this class. The court of directors was originally composed of 24 stockholders, qualified by the ownership of at least £2,000 of stock. By the act of 1853 the court consisted of 18 members, of whom 12 were elected by the stockholders, and 6 were chosen by the crown from men who had served in India. For expediting business, the members were annually divided into three committees: one on finance, and interior and marine interests connected therewith; the second on politics and war; and the third on the judicial and legislative interests. The most important part of the court of directors, however, was the secret committee. To this, composed of the chairman, deputy chairman, and the senior director, were referred all confidential communications between the board of control and the court. The despatches of the board as to political matters were transmitted through the secret committee, and might be sent on by them without being submitted to the court. The chief privilege of directorship was that of making appointments; the directors filled all vacancies, not only in the English branch of the company's service, but in all the subordinate functions in India. The board of control, the governing power in the company, consisted at first of six members, but afterward the sovereign had the privilege of appointing a suitable number, of whom the lord president of the council, the lord privy seal, the first lord of the treasury, the two principal secretaries of state, and the chancellor of the exchequer must form part. The powers of the board increased until long before its abolition in 1858 it had become a court from whose decisions there was no appeal.—The expense of the company's military force in the East Indies in 1856 was £10,229,584. The debts of the Indian government in England on May 1, 1857, amounted to £9,377,401, and the credits to £5,488,467, leaving a surplus of debts of £3,888,934. The Indian revolt of 1857-'8 called public attention more forcibly than at any previous period to the management of Indian affairs by the company, and led to the passing (Aug. 2, 1858) of the act "for the better government of India," by which "all the territories heretofore under the government of the East India company are vested in the British queen, and all its powers are to be exercised in her name, one of the principal secretaries of state to have all the powers hitherto exercised by the company or by the board of control. The military and naval forces of the East India company are to be deemed the forces of the queen, and all persons holding any office, employment, or commission in India are transferred to the service of the crown. All functions and powers of the courts of directors and proprietors are to cease, to-

gether with the salaries paid, and the board of control is likewise abolished." This act, although depriving the East India company of all its power and importance, did not abolish it, and provided for the manner in which the directors should thereafter be appointed; but its functions are by it almost exclusively confined to the administration of the stock and the distribution of the fixed interest or dividends upon the old share capital of the company.

**EAST INDIES**, a vague geographical term applied to southern Asia east of the Indus, and to the adjacent islands. (See **INDIA**.) The name India was unknown to the earlier Greeks, and the later ones used it to signify an indefinite extent of country lying beyond the Indus, of which they had a very imperfect knowledge. The modern Europeans applied it in much the same way until after the discovery of America. Columbus supposed that he had reached India by sailing westward, and the lands discovered by him and the other Spanish navigators in the western hemisphere were for a time collectively known as India. The king of Spain assumed the title of king of the Indies, and the council for the colonies was styled the supreme council of the Indies. When the mistake was discovered, the distinctive term West Indies was applied to America, and that of East Indies to Asiatic India. In process of time the term West Indies became restricted to the islands lying between North and South America, and the term India to the two peninsulas of Hither and Further India. The latter country is also called Chin-India or Indo-China, and in its most restricted sense the term India now includes only the western of the two peninsulas, or Hindostan in the wider sense. The term East Indies, as vaguely and popularly used, comprises Hindostan, Burmah, Siam, Laos, Anam, Malacca, Ceylon, Sumatra, Java, Borneo, Celebes, the Sunda and Banda islands, the Moluccas, the Philippines, and the rest of that vast archipelago, and is sometimes extended even to China and Japan.

**EASTLAKE**, Sir **Charles Lock**, an English painter, born in Plymouth in 1793, died in Pisa, Italy, Dec. 23, 1865. He commenced the study of art at the royal academy, under the direction of Fuseli, and continued it at the Louvre in Paris. He was compelled to leave France by the return of Napoleon from Elba, of whom he painted soon after a portrait, as he appeared at Plymouth on board the *Bellerophon* on his way to St. Helena. In 1817 he went to Rome, and remained there for many years, with the exception of visits to Greece, Sicily, &c. Among his most celebrated paintings are one in illustration of a passage in Byron's "Dream," "Christ weeping over Jerusalem," "Escape of Francesco di Carrara," "Pilgrims arriving in sight of Rome," "Christ blessing little Children," "Hagar and Ishmael," and the "Raising of Jairus' daughter." In 1841 he was appointed secretary to the royal commission on fine arts; from 1843 to



1847 he was keeper of the national gallery; and in 1850 he was knighted, made president of the royal academy, and director of the national gallery. He was the author of notes to Kugler's "Handbook of Painting," which was translated by Lady Eastlake, and of "Materials for a History of Oil Painting."—Lady Eastlake, whom he married in 1849, had acquired before her marriage, while Miss Elizabeth Rigby, literary reputation by the publication of "Letters from the Shores of the Baltic" (1841), "Livonian Tales" (1846), and other writings. She is also an artist of considerable ability. Eastlake's life was published by Lady Eastlake (London, 1870), who also edited his posthumous "Contributions to the Literature of the Fine Arts."

**EASTLAND**, a N. W. county of Texas intersected by Leon river; area, 900 sq. m.; pop. in 1870, 88. The central portion is hilly, the E. part is covered with post oak, &c., and some fertile prairies exist in the west. In 1870 there were 14,041 cattle.

**EAST LIVERPOOL**, a village of Columbiana co., Ohio, on the right bank of the Ohio river, and on the Cleveland and Pittsburgh railroad, about 35 m. N. W. of Pittsburgh; pop. in 1870, 2,105. It is famous for its potteries. The manufacture of china and parian ware has been recently commenced. It contains 16 manufactories of earthen ware, 2 of red brick, 2 of terra cotta, 1 of barrels, 2 flour mills, 2 planing mills, an iron foundry, 2 weekly newspapers, and several schools and churches.

**EASTMAN, Charles Gamage**, an American poet, born in Fryeburg, Me., June 1, 1816, died in Burlington, Vt., in 1861. He early went with his parents to Barnard, Vt.; was editor of the Burlington "Sentinel" in 1835-'6; commenced the "Lamoille River Express" newspaper at Johnson, Vt., in 1838; established the "Spirit of the Age" at Woodstock, Vt., in 1840; and purchased the "Vermont Patriot" and removed to Montpelier in 1846. He was postmaster at Woodstock and Montpelier for several years, and senator for Washington county in 1851-'2. He published a volume of poems in 1848, was a contributor of poetry to reviews and magazines, and pronounced poems at the university of Vermont, and at Dartmouth and other colleges.

**EASTMAN, Mary Henderson**, an American authoress, born in Warrenton, Fauquier co., Va., about 1817. In 1835 she married Capt. Seth Eastman of the U. S. army (author of a "Treatise on Topographical Drawing," and of the illustrations to national publications on the Indians, 1850-'57), with whom she resided for many years at Fort Snelling, Min., and at other frontier stations. She has published "Dacotah, or Life and Legends of the Sioux" (New York, 1849); "Romance of Indian Life" (Philadelphia, 1852); "Aunt Phillis's Cabin," a reply to Mrs. Stowe's "Uncle Tom's Cabin" (1852); "American Aboriginal Portfolio"

(1853); and "Chicora and other Regions of the Conquerors and the Conquered" (1854).

**EAST NEW YORK**, a post village of the town of New Lotts, Kings co., New York, joining the S. E. extremity of Brooklyn; pop. about 5,000. It is built on elevated land, fanned by the sea breezes, and is very healthy. Most of the residents are employed in New York or Brooklyn. Cypress Hills cemetery and the cemetery of the Evergreens are near its borders. The village is at the terminus of a branch of the Long Island railroad from Jamaica, and is connected by horse cars with the Brooklyn ferries. It contains a few manufactories, several schools, two weekly newspapers, and five churches. An unsuccessful attempt was made in 1873 to annex it, with the rest of Kings co., to Brooklyn.

**EASTON**, a borough, and the capital of Northampton co., Pennsylvania, on the right bank of the Delaware river, between the mouths of the Lehigh river and Bushkill creek, opposite Phillipsburg, N. J., and 54 m. N. of Philadelphia; pop. in 1850, 7,250; in 1860, 8,944; in 1870, 10,987. Excepting the eastern part of the town, the site is hilly, but the plot is nevertheless very regular, and the streets are wide and at right angles. The town has a public square, is lighted with gas, and supplied with water from the Lehigh river. The height of reservoirs on the surrounding hills is so great that a large portion of the town fires are extinguished without the aid of engines. A handsome cemetery of 40 acres has been laid out on picturesque and broken ground overhanging the Bushkill creek. There is a farmers' and mechanics' institute, whose buildings and grounds cover 30 acres, where fairs are annually held. The rivers are each spanned by several bridges, and the town is connected with the anthracite region, and with New York, Philadelphia, and the west, by means of the Lehigh, the Morris, and the Delaware canals, and the Lehigh Valley, the Lehigh and Susquehanna, the Central New Jersey, the Morris and Essex, the Belvidere Delaware, and the Delaware, Lackawanna, and Western railroads. Being the outlet of a rich agricultural region, Easton formerly manufactured and exported a large amount of agricultural products. The surrounding country contains inexhaustible deposits of the best iron ore, which is largely manufactured here; and within 12 miles are found large deposits of the best zinc ore, which is manufactured near the mines. The borough contains 3 lager-beer breweries and 4 bottling establishments, 3 tanneries, extensive paint works, 3 carriage factories, 3 machine shops and founderies, 3 manufactories of cabinet ware, a pottery, 2 sash and blind factories, an extensive rope walk, an oil refinery, and 3 banks, with an aggregate capital of \$987,600. In South Easton, a borough on the opposite bank of the Lehigh (pop. in 1870, 3,167), are a cotton factory, a blast furnace, a large wire and

rolling mill, and the machine shops of the Lehigh Valley railroad. Easton is the seat of Lafayette college (Presbyterian), organized in 1831, which in 1872 had 25 professors and instructors, 259 students, and a library of 9,000 volumes. A scientific department was organized in 1865. There are 35 public schools, with 90 teachers. The Easton library association has 6,000 volumes. There are 2 daily and 4 weekly newspapers, a free reading room, and 14 churches.—The borough was laid out in 1738 and incorporated in 1789. The Six Nations and seven other Indian tribes met here in council in 1758 with the governors of Pennsylvania and New Jersey and Sir William Johnston. Gen. Washington made it in the revolution a rendezvous for numbers of British prisoners.

**EASTPORT**, a town of Washington co., Maine, and the port of entry of Passamaquoddy district, situated on the boundary line between the United States and New Brunswick, about 90 m. E. of Bangor; pop. in 1870, 3,736. Its area is little more than 3 sq. m., comprising Moose island and several smaller islands in Passamaquoddy bay. It was incorporated in 1798. The village is compactly built on the S. E. shore of Moose island, and communicates with the mainland by a covered bridge 1,200 ft. long to Perry, and by ferries to Lubec and other places. The town has a spacious harbor, in which the tides rise more than 25 ft., and which is never blocked up by ice. In the season of navigation regular lines of steamers run up the river St. Croix to St. Andrew's and Calais, and also to Boston, Portland, and St. John, N. B. The harbor is defended by Fort Sullivan, which stands on a hill in the midst of the village. The custom house is a fine building of brick and stone, erected in 1850 at a cost of \$36,500. The trade with the neighboring British provinces is large, and lumber is exported in considerable quantities. Eastport is also the seat of a considerable fishing business. Large quantities of herring are taken in weirs about the shores of the bay. The value of imports from foreign countries for the year ending June 30, 1872, was \$933,536; exports to foreign ports, \$1,036,350. The town contains a national bank, a savings institution, a fire insurance company, a weekly newspaper, six school houses, which have an average attendance of about 450 pupils, and seven churches.—Eastport was captured by a British force July 11, 1814. It was claimed as included in the original limits of the province of New Brunswick, and the British commissioners at Ghent refused to agree to the surrender of the island in Passamaquoddy bay. The matter was referred to another commission, and on June 30, 1818, the place was surrendered to the United States. During the four years of military occupation it was governed by martial law.

**EAST RIVER**, a strait connecting New York bay with Long Island sound, about 18 m. long,

and between New York and Brooklyn about three fourths of a mile wide. It leaves the sound at a point called Throg's neck, where there is a lighthouse with a fixed light, and where Fort Schuylcr defends the N. E. approach to New York; and it enters the bay S. E. of Manhattan island, between the metropolis and Brooklyn. It also communicates with the Hudson by a narrow channel called Harlem river and Spuyten Duyvel creek, which separate Manhattan island from the mainland. It has a rapid current caused by the tide from the Atlantic, which, gathering force as it flows W. into the narrowest part of the sound, reaches its greatest height in the East river, arrives at New York three quarters of an hour earlier than that which rises in the bay, and drives upward along the E. shore of the Hudson many miles in advance of the tide on the W. shore. The East river is navigable by vessels of the largest size, and is crossed by numerous steam ferries. It contains several islands, and has a pass called Hellgate, 7 m. from New York bay, the navigation of which is attended with considerable danger; but extensive blasting operations are now (1874) in progress at the expense of the United States government to remove all the obstacles to navigation. (See **BLASTING**.)

**EAST RIVER BRIDGE**. See **BRIDGE**, and **BROOKLYN**.

**EAST SAGINAW**, a city of Saginaw co., Michigan, on the E. bank of Saginaw river, about 16 m. above the bay of the same name, opposite and a little below the city of Saginaw, 57 m. N. N. E. of Lansing, and 90 m. N. N. W. of Detroit; pop. in 1860, 3,001; in 1870, 11,350, of whom 5,066 were foreigners. The city extends along the river, nearly N. and S., about 3 m., and is built up for about a mile back. The business portions are constructed chiefly of brick, and several of the schools and churches are handsome edifices. Three swing bridges cross the Saginaw at this point, and there are two street railroads. The Flint and Pèrè Marquette railroad passes through the city, from which radiate a branch to Bay City and another (in progress) to Caro, Tuscola co. It is also the terminus of the Saginaw Valley and St. Louis railroad, while the Jackson, Lansing, and Saginaw line runs along the opposite bank of the river. It is the principal depot of the lumber and salt trade of the Saginaw valley, and is largely engaged in furnishing provisions and supplies to the lumber regions in the vicinity. It contains 5 founderies and machine shops, 2 boiler shops, 5 saw mills, a shingle and stave mill, and 4 salt manufactories, producing 102,752 barrels of salt in 1872. There are also several shingle and saw mills on the opposite side of the river. The car and repair shops of the Flint and Pèrè Marquette railroad employ about 500 men. There are 3 national banks, with an aggregate capital of \$500,000, and a savings bank, with \$100,000 capital. The city is divided into six

wards, and has more than a mile of paved streets, and an extensive system of sewers in progress. Water works are also in process of construction. An excellent system of public schools is in operation, embracing in 1872 1 high, 8 grammar, and 22 primary schools, with 34 teachers and 1,628 pupils. The expenditures for school purposes during the year were \$46,375, of which \$20,350 were for permanent improvements, and \$15,859 for teachers' wages. There are 2 daily and 4 weekly (1 German) newspapers, and 10 churches.—East Saginaw was laid out in 1850; about 1855 it was incorporated as a village, and in 1859 a city charter was granted.

**EATON**, a S. county of Michigan, intersected by Grand river; area, 576 sq. m.; pop. in 1870, 25,171. The surface is undulating. In the N. and middle part are forests, and in the S. plains with scattered trees. The soil is productive. The Peninsula railroad and the Grand River Valley division of the Michigan Central railroad pass through it. The chief productions in 1870 were 326,377 bushels of wheat, 231,955 of Indian corn, 300,308 of oats, 16,876 of barley, 177,313 of potatoes, 31,212 tons of hay, 749,464 lbs. of butter, 221,732 of wool, 204,028 of maple sugar, and 213,611 of hops. There were 5,526 horses, 6,423 milch cows, 8,932 other cattle, 49,733 sheep, and 10,243 swine; 6 manufactories of agricultural implements, 9 of carriages and wagons, 5 of furniture, 5 of iron castings, 5 of saddlery and harness, 3 of sashes, doors, and blinds, 4 flour mills, 4 planing mills, 36 saw mills, 1 wool-carding and cloth-dressing, and 5 wood-turning and carving establishments. Capital, Charlotte.

**EATON, Amos**, an American physicist, born in Chatham, N. Y., May 17, 1776, died in Troy, May 6, 1842. He was early employed as a surveyor, graduated at Williams college in 1799, was admitted to the bar in 1802, and settled in Catskill as a lawyer and land agent. For several years he devoted his leisure to the study of the natural sciences, in 1810 delivered at Catskill a popular course of lectures on botany, and in 1817 he lectured at Williams college on chemistry, geology, and mineralogy. His lectures were repeated in several New England towns and cities, and in 1818, by the invitation of Gov. Clinton, before the legislature of New York. While in Albany he made suggestions which ultimately resulted in the publication of "The Natural History of New York." In 1820-'21, in connection with Drs. T. Romeyn Beck and Lewis C. Beck, and at the expense of Stephen Van Rensselaer, he made geological and agricultural surveys of Albany and Rensselaer counties, the beginning of such surveys in the United States, reports of which were published. In 1820 he was made professor of natural history in the medical college at Castleton, Vt. Van Rensselaer subsequently employed him to make a geological survey of the district adjoining

the Erie canal, and the result was published in 1824, together with a profile section of rock formations from the Atlantic ocean across Massachusetts and New York to Lake Erie. In 1824 the Rensselaer school of science (now polytechnic institute) was established at Troy, and Eaton was placed at its head as senior professor. His works, of which several editions have been published, are: "Elementary Treatise on Botany" (1810); "Manual of Botany" (1817); "Botanical Dictionary" (1817); "Botanical Exercises" (1820); "Botanical Grammar and Dictionary" (1828); "Chemical Note Book" (1821); "Chemical Instructor" (1822); "Zoological Syllabus" (1822); "Cuvier's Grand Division" (1822); "Philosophical Instructor" (1824); "Directions for Surveying and Engineering" (1838); "Geological Text Book" (1830); "Geological Note Book" (1841); and extended reports of several geological and agricultural surveys.

**EATON, George W.**, an American clergyman and educator, born near Huntingdon, Pa., July 3, 1804, died at Hamilton, N. Y., Aug. 3, 1872. He graduated at Union college in 1829, and was appointed a tutor. From 1831 to 1833 he was professor of ancient languages in Georgetown college, Ky. In 1833 he became connected with the Hamilton literary and theological institution (Baptist), incorporated in 1846 as Madison university, where he was successively professor of mathematics and natural philosophy, of civil and ecclesiastical history, and of systematic theology. He was president of the university from 1856 to 1868, and president of the theological seminary and professor of homiletics from 1861 to 1871.

**EATON, William**, an American soldier, born in Woodstock, Conn., Feb. 23, 1764, died in Brimfield, Mass., June 1, 1811. At the age of 16 he enlisted in the revolutionary army, from which he was discharged in 1783. In 1790 he graduated at Dartmouth college, and two years later received a captain's commission in the army. In the summer of 1797 he was appointed American consul at Tunis, arrived there in March, 1799, and for several years was engaged in a series of negotiations and altercations with the bey, having reference to the annual payment of tribute money. In this he acted with a boldness and tact which secured to the commerce of his country an immunity from the attacks of Tunisian cruisers. In 1803 he returned to the United States, received the appointment of navy agent of the United States for the Barbary states, and accompanied the American fleet to the Mediterranean in the summer of 1804. Learning that Hamet Caramelli, rightful bey of Tripoli, with which the United States were then at war, had taken refuge in Egypt, he sought him out, and in the early part of 1805 assisted him in assembling a force of about 500 men, four fifths of whom were Arabs, the remainder being Christian adventurers, principally Greeks, with nine Americans. Having secured the coöperation of the

American fleet, the little army, under the command of Eaton, took up its march across the Libyan desert for Derne, the capital of the richest province of Tripoli, a distance of about 600 miles. On several occasions the mutinous disposition of the Arab sheiks and the irresolution of Hamet imperilled the safety of the handful of Christians belonging to the expedition; but the forces were brought in safety to Bomba, on the coast, where the American ships Argus and Hornet were in waiting. On April 27, with the assistance of the ships of war, Eaton attacked and carried Derne after a furious assault, in which he was wounded. A few days later an army of several thousand Tripolitans, despatched by the reigning bey, approached the town, and for several weeks occasional sharp skirmishes took place between the opposing forces, Eaton's army having meanwhile been considerably augmented. On June 11 a general engagement was fought, and the enemy was totally routed and driven back to the mountains. At this moment, when Eaton was preparing by a rapid march to fall upon Tripoli, reinstate Hamet on the throne, and release the American captives detained there without ransom, intelligence arrived that a peace had been concluded by Col. Tobias Lear, the American consul general at Algiers, one of the conditions of which was that \$60,000 should be paid the bey for the ransom of the Americans. Eaton soon after returned to the United States, where he received many marks of popular favor, the legislature of Massachusetts voting him 10,000 acres of land. The remainder of his life was passed in Brimfield, Mass., which town he at one time represented in the state legislature. A memoir of him was published in Brookfield, Mass., in 1813; and another, by C. C. Felton, is contained in Sparks's "American Biography."

**EAU CLAIRE**, a W. county of Wisconsin, intersected by Chippewa and Eau Claire rivers; area, 648 sq. m.; pop. in 1870, 10,769. The surface is uneven, and the soil fertile. The West Wisconsin division of the Milwaukee and St. Paul railroad passes through it. The chief productions in 1870 were 205,827 bushels of wheat, 69,964 of Indian corn, 294,493 of oats, 18,336 of barley, 29,011 of potatoes, 5,760 tons of hay, and 124,365 lbs. of butter. There were 1,458 horses, 1,834 milch cows, 2,509 other cattle, 1,864 sheep, and 1,839 swine; 7 manufactories of carriages and wagons, 4 of furniture, 3 of iron castings, 2 of machinery, 4 of sashes, doors, and blinds, 5 of bricks, 3 flour mills, 23 saw mills, and 4 breweries. Capital, Eau Claire.

**EAU DE COLOGNE**, or **Cologne Water**, alcohol perfumed with essential oils, named from the city of Cologne, in which its manufacture is extensively prosecuted, and from which several million bottles are annually exported. It was first made at Cologne in the 17th century by an Italian named Feminis, and after him, there as well as in Italy, by an Italian family

named Farina, the most famous of whom was Giovanni Maria Farina, who succeeded to the business in 1709. His name is now adopted by several of the manufacturers of Cologne, and in other countries it is attached to very different preparations, resembling the genuine only in the bottles and labels. Numerous recipes are given for this preparation, most of which are very complicated from the great number of ingredients. Purity of the volatile oils, and also of the alcohol, and freedom especially of the latter from fusel oil, are essential to the perfection of the perfume. It is also important that no one of the volatile oils should so predominate that its odor may be perceived above the rest. Distillation after mixing is recommended in some cases, and in others contemned, as the volatile oils do not distil over so readily as the spirit. When not distilled, the mixtures should stand for some weeks or months, that the oils may be thoroughly dissolved in the alcohol. The following is given as the process of Farina in the *Dictionnaire des arts et manufactures*: balm and mint of Notre Dame, each 350 grams; petals of roses and violets, each 120; lavender flowers, 60; absinth (wormwood), 30; sage and thyme, each 30; orange flowers, nutmegs, mace, cloves, and cinnamon, each 15; camphor and angelica root, each 8. These ingredients are digested in 660 lbs. avoirdupois of rectified alcohol for 24 hours, adding two lemons and two oranges cut into slices. The mixture is then distilled by heat of the sand bath until 440 lbs. have passed over. To this product are then added essences of lemon, of cedrat, of balm, and of lavender, each 45 grams; essences of neroli and of rosemary, each 15; essence of jasmine, 30; essence of bergamot, 350. The whole are thoroughly mixed and then filtered. It is also prepared without distillation, but the odor is never so fine. Several recipes are published for imitations which may be more cheaply prepared.

**EAU DE LUCE** (*agua lucia*), a liquid soap made by mixing a little oil of amber and mastic or balm of Gilead with ammonia. It is a remedy for the bites of poisonous animals. The compound tincture of ammonia is substituted for it, made by dissolving 2 drachms of mastic in 9 fluid drachms of rectified spirit, pouring off, and adding a pint of strong ammonia, and 14 minims of oil of lavender.

**EBAL AND GERIZIM**, two mountains in Palestine, within 200 paces of each other, and separated by a deep valley, in which stood the old city of Shechem, now Nablus. They are much alike, being semicircular, about half a league long, and on the sides nearest Shechem nearly perpendicular. Ebal is 1,028 ft. above Nablus and 2,700 ft. above the sea; Gerizim about 100 ft. lower. They were made memorable by the solemn ratification of God's covenant with the Jews after they had passed over Jordan, when six tribes were placed on Gerizim and six on Ebal, the former to pronounce blessings on

those who should faithfully keep the divine law, and the latter to pronounce curses on those who should violate it; whence Gerizim was known as the mount of blessing and Ebal as the mount of cursing. According to the injunction of Moses, the Jews after obtaining possession of Canaan built an altar and celebrated a feast on Ebal. The Samaritans contended that this should have been done on Gerizim, and they built a temple on the latter, the ruins of which are still visible, and regarded it as the Jews regarded their temple at Jerusalem. They also held that Gerizim was the mountain upon which Abraham was directed to offer up Isaac. The remark of the Samaritan woman to Christ at Shechem (John iv. 20) is in allusion to this difference of opinion as to the proper place of worship. The Samaritans still have an annual sacrifice on Mt. Gerizim.

**EBELING, Christoph Daniel**, a German scholar, born near Hildesheim, Hanover, in 1741, died in Hamburg, June 30, 1817. He was noted for his extensive knowledge of oriental languages, of classic and foreign literature, and of history and geography. One of his publications was a history and geography of North America (7 vols., Hamburg, 1796-1816), forming a continuation of Büsching's general geography, for which he received a vote of thanks from the United States congress. He paid special attention to the geography of the new world, and collected about 10,000 maps and nearly 4,000 books, all relating to America. This library is now in Harvard college.

**EBENEZER**, the name of a place where the Israelites were defeated when the ark of God was taken (1 Sam. iv. 1), and also of a memorial stone or monument set up by Samuel to commemorate their victory over the Philistines at Mizpeh, when God interposed for their deliverance (1 Sam. vii. 5-12). The compound word signifies the stone of help. The monument was erected by the prophet, saying, "Hitherto hath the Lord helped us." The name of the place, though mentioned first, was probably of later use, being borrowed from that of the monument.

**EBERHARD IM BART** (Eberhard with the Beard), the first duke of Würtemberg, born Dec. 11, 1445, died Feb. 14, 1496. His father, Count Louis the Elder, dying while he was young, his education was neglected. Before he was 14 he wrested the government from his uncle Ulric, who had been appointed regent. A pilgrimage to the Holy Land, and the influence of his wife, the princess Barbara of Mantua, had a happy effect upon his character. He became celebrated in German history as the founder of the undivided sovereignty and of the representative constitution of Würtemberg. He devoted himself to study, promoted science and literature, and founded in 1477 the university of Tübingen. He improved the laws and the condition of the convents in his country, and was a friend of peace. The emperor Maximilian of Germany, who confer-

red on him the title of duke (1495), declared at his grave several years afterward: "Here lies a prince who has left no equal in the German empire in princely virtues, and whose advice I have frequently followed with advantage."

**EBERHARD, Johann August**, a German philosopher, born in Halberstadt, Aug. 31, 1739, died Jan. 6, 1809. He was first a teacher, and then a pastor. In a work entitled *Neue Apologie des Sokrates* (3d ed., Berlin, 1788), he opposed the opinion which had been lately advanced that the virtues of the pagans were only splendid vices. A religious romance entitled *Amyntor* did not, as it was designed to do, cause the bold assertions of this apology to be forgotten. In 1778 he was appointed professor of philosophy in the university of Halle, and soon after a member of the academy of Berlin. He was attached to the philosophy of Leibnitz and Wolf, and combated the systems of Kant and Fichte. His writings on philosophical and æsthetical subjects are numerous.

**EBERHARD, Konrad**, a German sculptor and painter, born at Hindelang, Bavaria, Nov. 25, 1768, died in Munich, March 13, 1859. He studied at Munich and Rome, and in 1816 became professor of sculpture in the academy of fine arts at Munich. He painted many pictures illustrating the conflicts, progress, and triumphs of the Christian religion. Among his best works are the tomb of the princess Caroline in the *Theatinerkirche*, and the statues of St. George and St. Michael before the Isar gate in Munich.

**EBERS, Georg Moritz**, a German Egyptologist, born in Berlin, March 1, 1837. He studied at Göttingen and Berlin, and taught for several years at the university of Jena. After a visit to Egypt, Nubia, and Arabia, he received in 1870 a professorship at Leipsic. His first publication, *Eine ägyptische Königstochter* (3 vols., Stuttgart, 1864), which describes the subjugation of Egypt by the Persians in the style of a historical novel, has passed through numerous editions, and was translated in Holland, England, and America (New York, 1871). His subsequent works are more scientific; the most important are *Aegypten und die Bücher Mose's* (1st vol., Leipsic, 1868) and *Durch Gosen zum Sinai* (1872).

**EBIONITES** (Heb. *ebyonim*, poor people), a party in the early Christian church. The name was first assumed by such Christians as held to Jewish opinions and practices. After the Christianity which savored of Judaism had come to be regarded by the church as a heresy, the name, in its Greek form, was applied to the members of the party by their opponents, and they themselves adopted that of Nazarenes. The doctrine of the Ebionites was a mixture of Judaism and Christianity. While they accepted the Old Testament in its integrity, they rejected the New Testament, substituting a gospel based upon the facts in the Gospel of Matthew. This was known to the primitive Christians as the "Gospel of the Hebrews."

The Ebionites denied the divinity of Christ, retained the practice of circumcision while observing the rites of baptism and the Lord's supper, kept the seventh day of the week, and conformed in many things to the ascetic discipline of the Essenes. Their opinions were afterward somewhat modified, and they were divided particularly in their dogma concerning the birth of Jesus and the method of his union with God. As Epiphanius represents them, they believed that Jesus was the incarnation of an exalted superangelic spirit, who came to republish the law which Moses had published before, and which was the law of right and truth given to the original Adam. They were opposed to the doctrine of priestly and monastic celibacy. They interpreted literally the Hebrew prophecies in regard to the Messiah's kingdom, and expected that material reign of Christ which Isaiah describes. Ebionites were found in Palestine and Syria down to the end of the 4th century. They began about that time to come into frequent collision with the Catholics, and soon disappeared from history.

**EBN.** See BEN.

**EBOLI**, *Anna de Mendoza*, princess of, a Spanish lady of the 16th century, daughter of a viceroy of Peru. At an early age she was introduced at the court of Philip II. by her husband the prince of Eboli, a favorite of the king and preceptor of his son Don Carlos. Though one of her eyes was defective, her beauty attracted general attention, and she became noted for her amorous as well as political intrigues. Among her admirers were the king and his secretary of foreign affairs, Antonio Perez. She was implicated in the assassination of Escovedo, the envoy of Don John of Austria.

**EBONY** (*diospyros ebenum*, Willdenow), a tree with hard, heavy wood, native of the East Indies. The black ebony, the most highly prized, grows spontaneously in Ceylon, Madagascar, and Mauritius. There are other colors, such as green, red, yellow, and white and black striped. There is another kind called ironwood from its intense hardness. The heart wood of *D. reticulata*, a lofty tree in Mauritius, is also esteemed. The ebony of the Comandel coast is derived from *D. melanoxylon* (Roxburgh). Ebony is likewise procured from *D. tomentosa* and *D. Roylei* of the East Indies. The fruit of many of the ebony trees is considered edible by the natives, although it is generally astringent. The famous oblivion-producing fruit of the lotus is supposed to be that of *D. lotus* of Africa. The date plum and persimmon are representatives of this genus.

**EBRO**, a river of Spain, the Iberus of the Romans, which gave the name of Iberia to the country it waters. It rises in the mountains on the N. border of Spain, in the province of Santander, and flows S. E. at first between lofty and picturesque heights, separating Álava and Navarre from Old Castile, intersecting Aragon near its centre, and after a course of about 400 m. emptying into the Mediterranean through

a double embouchure at Cape Tortosa, near the S. extremity of Catalonia, in lat. 40° 42' N. At Mequinenza it passes through a defile where once was probably a barrier restraining its waters as a lake in the country of Aragon. Its principal tributaries are the Aragon, Gallego, and Segre, on the left or N. side, and the Oca, Jalon, and Guadalupe, on the right or S. It abounds with shoals and rapids, but boats may pass with difficulty as high as Tudela in Navarre. A canal has been cut parallel with its bank from Tudela to Sastago, about 40 m. below Saragossa. Improvements have also been made in the bed of the river lower down, and from a point near Amposta the San Carlos canal has been opened southerly across the delta to the harbor of Los Alfaques. The principal traffic is the transport of grain, and the floating of timber from the northern forests. The Ebro was the boundary between the possessions of Rome and Carthage, and afterward between those of Charlemagne and the Moors.

**ÉCARTÉ**, a game of cards, played by two persons with a piquet pack, or pack from which the twos, threes, fours, fives, and sixes have been taken, leaving 32 cards. These rank as follows: the king is the highest card, and queen, knave, ace, ten, nine, eight, and seven follow in succession, the only peculiar feature being the position of the ace below the court cards and above the rest. The pack having been shuffled as usual (the deal belonging to the player cutting the highest card by whist rules), five cards are dealt to each person, two and three or three and two at a time, as in the American game of euchre. The eleventh card is turned as in that game, and determines the trump, the rest of the pack being called the talon. If the non-dealer is satisfied with the hand he holds, he now plays, first naming the suit he intends leading. If his adversary has a higher card of the suit led, he is obliged to take the trick; but he is not obliged to trump, though of course permitted to do so. The holder of the king of trumps must declare, before playing at all, that he has it, by saying "I have the king." If he leads the king, he may declare it just after putting it down, but before it is covered by his adversary's card, else he cannot score it in that hand, *i. e.*, he cannot count the one point to which his holding or turning up the king would otherwise entitle him. The winning three tricks also counts one point; the winning all (called having the vole) counts two; five points make game. If the non-dealer, contrary to what has been thus far assumed, is not satisfied with the cards dealt to him, he says, before playing, "I propose;" and the dealer, if he also wishes other cards, assents. The non-dealer then throws aside such cards as he wishes to reject (called the discard), and the dealer gives him, from the top of the talon, a corresponding number to take their place. The dealer also exchanges his own cards in the same manner; but both must discard before the fresh cards

are seen. If both the players agree, they may continue discarding, and so changing their hands, until the talon is exhausted; but one cannot keep on after the other is satisfied; and if it is found, after several discards, that too few cards remain in the talon to supply the number required, this must be made up from the cards last discarded. If the dealer will not consent to allow his adversary an exchange after the first deal, he is obliged to win three tricks, or if he fails loses two points; and if the non-dealer plays without requesting a discard, he is subject to the same conditions. If either party looks at the discards, he must as penalty play all the rest of the game with his cards exposed to his opponent's view. If the dealer turn up a trump by mistake in dealing cards for the discard, he is not permitted to refuse his adversary an exchange of cards during that hand. The general rules concerning mistakes, misdeals, &c., are the same as in similar games at cards.—Écarté had its origin in Paris, and derives its name from the French verb *écarter*, to discard.

**ECBATANA**, an ancient city, capital of the Median empire, and the favorite summer residence of the kings of Persia. Its foundation was attributed to Semiramis; but Herodotus makes Deioeces its founder, and describes particularly its position on a conical hill, and its enclosure by seven concentric walls, each inner one being higher than the next outer one, which were painted with different colors, the innermost wall being gilded, and the next plated with silver. An account of the building of the city by Artaphaxad is given in the book of Judith, and it is mentioned by Ezra under the name of Achmetha. It is probable that this city was founded and flourished subsequently to Babylon and Nineveh, and that it occupied the position ascribed to it by Diodorus and others, near the site of the modern city of Hamadan. Its citadel was of enormous strength, and adjoining it was the royal palace, rivalling the noblest edifices of the East. The fragrant cedar and the cypress were the only kinds of wood that entered into its construction, and its columns, beams, and ceilings were covered with golden and silver plates. Its splendid architecture and spacious apartments, its fountains and gardens, and the mild climate of the place, attracted to it, even after the fall of the Median empire, the sovereigns of Persia, to repose during the summer months. Darius fled from his defeat at Arbela to Ecbatana, and Alexander the Great, having become master of the town, bore away a rich booty. Under the Seleucidæ its edifices and palaces were plundered, and its ramparts began to crumble away. It subsequently fell to the Parthians, and was the frequent residence of their kings; but its ruin was completed amid the revolutions which preceded the establishment of the new Persian empire. Of its former magnificence only a few broken columns, cuneiform inscriptions, medals, and fragments of sculpture, dug from the

earth in the vicinity of Hamadan, now remain. (See **HAMADAN**.)

**ECCHELLENSIS**, or **Echellensis**, **Abraham**, a learned Maronite, professor of the Syriac and Arabic languages in Paris and in Rome, born at Ekkel, Syria, died in Italy in 1664. He was educated at Rome, and took the degree of doctor of theology and of philosophy. In 1630 he was invited to Paris to assist in editing the polyglot Bible of Le Jay. He contributed to this work the book of Ruth in Syriac and Arabic, and the third book of Maccabees in the latter language. He was besides the author of several historical writings and translations from the Arabic. In 1642 he returned to Rome as professor of the oriental languages.

**ECCLESIA** (Gr. ἐκκλησία, from ἐκκαλεῖν, to call out or summon), in ancient Athens, a general assembly of the citizens summoned together to discuss and decide matters of public interest. The ordinary assemblies were held three times monthly on established days; the extraordinary were specially convened on any sudden and pressing emergency. When the occasion was of extreme importance, special messengers were despatched into the country to summon the people, and the assembly thus convened was termed a cataclesia. These assemblies were originally held in the Agora; but during the most flourishing periods of Athens, in the times of Themistocles, Pericles, and Demosthenes, they were usually held on the rock of the Pnyx, where a semicircular space, partially formed by excavation from the native rock, and containing 12,000 square yards, could accommodate all the Athenian citizens. There were neither seats nor awning, and the assembly met at daybreak. The *bema* on which the orators stood to address the people was carved from the rock, and yet remains. It was often called "the stone;" and as the destinies of Athens were swayed by the orators who stood upon it, it became a figure of speech for the existing government, and the phrase "master of the stone" indicated the ruling statesman of the day. At a later period the assemblies were often held in the great theatre of Dionysus, and also in the Piræus, and in the theatre at Munychia. The right of convening the citizens was vested in the *prytanes*, or presidents of the council of 500, but in times of war or sudden emergency the generals also had the power to call extraordinary assemblies. Any citizen refusing to obey the call was fined. The poorer classes received a small fee for their attendance as a recompense for their time. Before the assembly entered upon any business, a sacrifice, usually of a suckling pig, was offered, and incense was burned. Then the herald proclaimed silence and offered a prayer to the gods; after which, under the direction of the prytanes and the *proëdri*, or heads of tribes, the subjects to be discussed were stated, and permission was given to the speakers to address the people. No measure could be acted upon in the assembly which had not been passed

upon by the senate, but the decrees of the senate might here be approved, altered, or rejected; and a new proposition might be introduced on any subject which had already been discussed in the senate. According to the older regulations, persons above 50 years of age had the privilege of speaking first; but this distinction was obsolete in the days of Aristophanes. No new decree could be publicly proposed till it had been shown to the *proëdri*, that they might see whether it contained anything injurious to the state or contrary to existing laws. The people voted either by show of hands or occasionally by ballot. The assembly could make inquisition into the conduct of magistrates, and in turbulent times exercised a power resembling that of impeachment, as in the cases of Demosthenes and Phocion. It was sometimes suddenly broken up at the occurrence of an unfavorable omen, as thunder and lightning, sudden rain, or any unusual natural phenomenon.—In later Greek and Latin the name signified the church.

**ECCLESIASTES**, or **The Preacher** (Heb. *Koheleth*, assembler), one of the didactic books of the Old Testament canon, professing to be the words of the preacher, the son of David, king in Jerusalem. It contains allusions to the writer's riches, palaces, and parables, and its sententious style reminds one of the author of the Proverbs. Yet its diction is marked by Chaldaisms and linguistic usages which are thought not to have been introduced into the Hebrew language till about the period of the Babylonish captivity. The authorship of Ecclesiastes was attributed to Solomon by nearly all the rabbinic commentators and patristic writers; but in modern times this view has been relinquished by all the writers of the various liberal schools without exception, and even by theologians like Hengstenberg, Stuart, and Keil; in fact, no prominent theologian of the 19th century has defended it. According to Hengstenberg and Keil, the book was compiled in the time of Nehemiah; according to Hitzig, about 200 B. C.; and according to Grätz, not until the Herodian time. Some entertain the opinion that its original form must have been a dialogue in which the sage carries on a discussion with a skeptic and a libertine. Yet it is more commonly regarded as the monologue of a Hebrew moralizing on life and searching for the highest good, scanning the perversities and follies of man, and at length, after a review of the evidence, declaring the verdict that obedience to God is the only real and substantial good.—Among the best commentaries on this book are those of Knobel (1836), Hitzig (1847), Stuart (New York, 1851), Elster (1855), Vaihinger (1858), Hengstenberg (1859; English translation, 1860), Ginsburg (London, 1861), Ewald (2d ed., 1867), and Grätz (1871).

**ECCLESIASTICUS**, one of the apocryphal books of the Old Testament, called also "The Wisdom of Jesus, the Son of Sirach." The author

appears to have lived in the 3d and 2d centuries B. C., and wrote in Hebrew, though no copy of the Hebrew original has been preserved; and his work was subsequently (probably about 130 B. C.) translated into Greek by his grandson. The book contains—1, an anthology of moral and prudential precepts for the various circumstances of life; 2, a discourse which the author puts into the mouth of wisdom herself, inviting men to virtue; and 3, a panegyric in which the author celebrates the praises of God and eulogizes the great men of his nation. In the Roman Catholic church it has been held as canonical since the council of Carthage, whose decision was confirmed by the council of Trent. The best commentary on the book is by Fritzsche (1859).

**ECHENEIS**. See SUCKING FISH.

**ECHEVERRIA**, *Estéban*, a South American poet, born in Buenos Ayres in 1809, died in Montevideo in 1851. He published his first poems in 1829, subsequently went to France, and on his return prepared several other volumes, after the style of Byron and Lamartine. *La cautiva* (1837), his best poem, contains exquisite descriptions of the pampas and the Argentine people. Rosas expelled him from Buenos Ayres, and he spent the latter part of his life in Montevideo, where in 1849 he published *La insurreccion del Sud*.

**ECHIDNA**. See PORCUPINE ANT-EATER.

**ECHINADES**, in ancient geography, a group of islands in the Ionian sea, off the coast of Acarnania, near the entrance of the gulf of Corinth. They were said to have been formed by the alluvial deposits of the river Achelous; and Herodotus says that many of them in his time had become reunited to the mainland. They took their name from the *echinus*, or sea urchin, in consequence of their sharp and prickly outlines. The largest of them was Dulichium, now a part of the mainland. Homer describes them as inhabited, but later writers speak of them as barren and deserted.—They are now called the Curzolari islands, and have five small villages, but their size is so small, and their productions so few, that they are of little importance. Lord Byron during his voyage from Cephalonia to Missolonghi, in January, 1824, took refuge among them, twice from storms and once from a Turkish cruiser. The great battle of Oct. 7, 1571, commonly called the battle of Lepanto, was fought off these islands instead of off the city of Naupactus, or Lepanto, and within the gulf, as the name implies.

**ECHINODERMS**, or *Echinodermata* (Gr. *ἐχίνος*, a hedgehog, and *δέρμα*, skin), the highest class of radiated animals, so named from the spines with which many of the genera are covered. They all have a tough envelope, containing calcareous particles, or a kind of shell of movable pieces, provided with tubercles or spines; the oral or abactinal region is beneath, the aboral or abactinal above, the parts radiating from the former and meeting above; along



certain of the rows of plates are perforations for the ambulacra or suckers used in locomotion, and between them the spine-bearing plates, when these exist. They have well developed muscles, and a nervous ring around the œsophagus, which sends off branches to the rays, which are generally five or a multiple of five. • Respiration is by means of branchiæ, by organs performing other functions, and by water passing into the general cavity of the body. They reproduce by means of eggs, and abound in almost all seas; some of the lower orders were among the earliest created animals, and the class ranges from the Silurian to the present epoch. They embrace the five orders of crinoids or stone lilies, ophiurans or brittle stars, asterioids or star fishes, echinoids or sea urchins, and holothurians or sea cucumbers, the last being the highest, and seemingly a connecting link between radiates and articulates. There is a remarkable persistency of form in the class from the earliest to the present time, some of the oldest being referred by Goldfuss to existing genera. They are essentially carnivorous.

**ECHINUS**, a genus of echinoderms, the type of the order echinoids, represented by the sea urchins or sea eggs common on our coast.

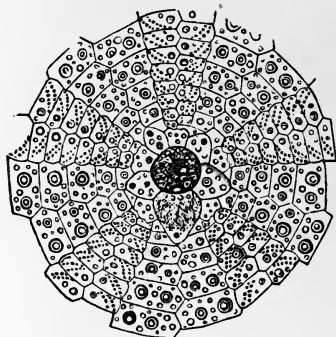

Sea Urchin, top view.

They have globular cases with flat bases, formed of calcareous plates accurately fitted together in rows of larger alternating with smaller plates, the former covered on the outside with movable spines; in some species they are 5 or 6 in. long, exceeding the diameter of the body. These spines fit by a ball-and-socket joint into little depressions, which occupy the centre of tubercles that cover the larger or ambulacral plates, and by the movement of the muscles which are attached to them they admit of considerable motion. Besides these organs of motion, upon which the weight of the animal not buoyed up by the water is sustained, hundreds of tubular feet, or ambulacra, project through openings in the smaller interambulacral plates. These may be thrust out beyond the spines, and, having a little sucker at their ends, they serve to take hold of any object that comes in contact with them; and

thus the animal may cause the shell to roll slowly, the spines aiding the motion. The tubular feet also serve to seize their prey, one foot after another fastening to it and passing it around to the mouth, which is in the centre of the under portion of the shell. This being furnished with a powerful arrangement of teeth, small shellfish and crabs are easily masticated. —The echinoids are divided into regular and irregular. The former, containing the globular

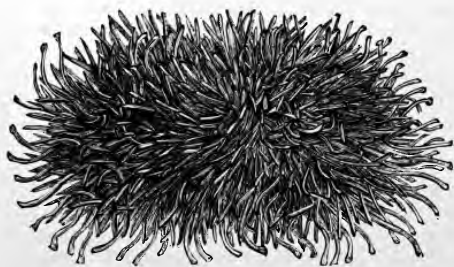

Sea Urchin (*Toxopneustes drobachiensis*).

genera, have the mouth below and the vent above, both central, and the ambulacra in five pairs continuous from vent to mouth; the dental apparatus is complicated. They vary from 1 to 4 in. in diameter, with spines of equal length. The common sea urchin of the American coast (*toxopneustes drobachiensis*, Ag.) is generally about an inch in diameter, and will be easily recognized by the above general description and by the figures. Some of the

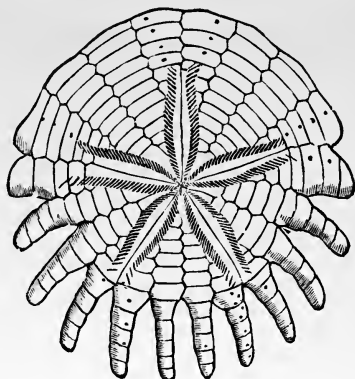

Rotula.

large species of tropical climates are used as food. In the *cidaris* family, which includes those best known, are more than 20 genera. The irregular echinoids have the mouth below, the vent sometimes below, sometimes at one side, and the ambulacra not continuous. In the family *clypeastridae*, in which the ambulacra resemble the petals of a flower, are the flat sea urchins, *echinarachnius parma* (Gray) and *mellita quinquefora* (Ag.), which are cov-

ered with soft velvety spines, living on sandy shores, where they lightly bury themselves, only discoverable after storms or in still days when they slowly change their places. In the globular forms the eye specks, which are at the end of the rays in the star fish, are drawn close together at the summit; at the same place is a curious little sieve or madreporic body, through which water is admitted to the five principal tubes of the interior. Sea urchins are able to bore holes in the hardest rocks, in which they lodge, enlarging the cavity as they increase in size, the opening remaining the same, so that they are prisoners for life. It is generally believed that they thus penetrate and excavate rocks by the constant motion of the microscopic vibratile cilia which cover their spines. The heart-shaped sea urchins, the spatangoids, bury themselves in mud

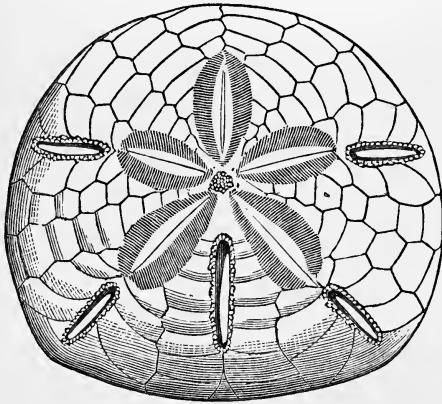

*Mellita quinquefora.*

and sand. Sea urchins are found from the upper Silurian to the present time; they were very abundant in the mesozoic age, especially in the chalk epoch.

**ECHO** (Gr. ἠχώ, from ἠχῆ, a noise), a sound reflected by an opposing surface and repeated to the ear of a listener. The nature of those pulses that are propagated through the air to the ear and produce the sensation of sound is fully explained under the latter title, where also it is shown that the sound pulse is partly reflected when it encounters in its path a medium of different elasticity or density; if the reflected sound reach the observer so long after the original sound as to constitute a distinct noise, it is called an echo. Simple echoes, and even those that repeat several times in succession the words of the human voice or other sounds, are familiar to all. Of more remarkable cases we may instance the following. A writer in 1766 states that at the Simonetta palace near Milan there was an echo that repeated 60 times the sound of a pistol; this echo does not now exist. Sir John Herschel quotes the case of an echo at Woodstock park that repeats 17 syllables in the daytime and 20 at

night. Dr. Page (1839) notices one at Belvidere, Allegany co., N. Y., that repeats three syllables distinctly 11 times, the observer standing between two barns. Most remarkable, however, are the phenomena of harmonic echoes, or those that repeat in a different key the direct sound. Dr. Page observed such an echo in Fairfax co., Va., which repeats 13 syllables three times; and if 20 notes be played on a flute, they are returned with perfect distinctness, but some of them are raised in pitch by a third, a fifth, or an octave, the effects varying with the state of the atmosphere. Tyndall describes the echoes of the Alpine horn rebounding from the rocks of the Wetterhorn or Jungfrau as dying away in successive reflections, gradually becoming more soft and flute-like. Dr. Brewer in his work on "Sound and its Phenomena" (1864) instances the following cases: Not far from Coblenz an echo is found that makes 17 repetitions at unequal intervals, some loud, some soft; some to the right, others to the left of the observer; some in unison with the direct sound, others a third, fifth, or tenth of the fundamental. At the lake of Killarney is an echo that renders an excellent second to any simple air played on the bugle. Some distance from Glasgow there was formerly a remarkable case in which eight or ten notes of a trumpet were repeated a third lower, and again a second and third time, each time lower still. The Hon. J. W. Strutt, now Lord Rayleigh, observed ("Nature," 1873) the sound of a woman's voice echoed from a plantation of firs, but its pitch raised an octave; with a man's voice the phenomenon could not be produced.—The various interesting peculiarities of echoes depend upon the conditions under which the reflection takes place, and the position of the observer with respect to the reflecting surfaces; these conditions may be so varied as to more or less affect the intensity and the quality of the original sound, and we will separately consider these two peculiarities. The intensity of a sound varies, other things being equal, directly as the solid angle included at the origin of the sound between the extreme limits of the wave that enters the observer's ear. If the reflecting surface be plane and so small that it subtends a smaller angle than the tympanum of the ear, the intensity of the observed echo will be diminished in proportion to the size of the reflector. If the effective surface be larger than this limit, and nothing of intensity be lost in the act of reflection, the echoes will be as loud as the direct sounds that have passed over the same length of path. There is however always in the act of reflection an actual loss, depending on the relative density and elasticity of the air and the reflecting body; this principle is applied to deaden the echoes within a poorly contrived auditorium, by encasing the bare walls in wooden panels or draping them with any light material. Two planes may be so placed that the reflected sounds proceeding from each reach the ob-

server at the same instant; he will then perceive an echo of twice the intensity of that produced by either reflector separately. The curvature of an elliptical mirror is such that all the rays of sound, or to speak more properly the whole wave of sound, that starts from one focus will be reflected precisely to the other focus, so that the ear placed at this point perceives a sound as intense as that at the origin; this principle is applied in the construction of whispering galleries, where, however, circular or other curved surfaces frequently replace the ellipse. If a sound originate near the focus of a parabolic mirror, the reflected portion of the wave will be confined to a cylindrical or conical space in front of the mirror; a principle that finds application in the construction of speaking trumpets and tubes, ear trumpets, sounding boards for pulpits, &c. The louder portions of the rolling of artillery or of a clap of thunder are doubtless sometimes the effect of a concentration of several echoes reflected from objects properly placed with respect to the observer. On the other hand, a convex surface scatters the waves of sound and diminishes the intensity of the echo; a principle that finds frequent application in the construction of large halls, whose walls, ceilings, pillars, &c., are covered with protuberant convex ornaments. If the reflecting surfaces are arranged in a promiscuous manner, there will be heard a confused mixture of echoes, each perhaps so faint that the direct sound greatly preponderates; and in the case of many public halls it will be noticed that if empty the speaker's voice is unpleasantly reëchoed, while if filled by an audience the echoes become much subdued and often inappreciable. So also a wave of sound passing through a mixture of heterogeneous bodies (such as a forest, currents of hot and cold air, a glass full of champagne, a stratum of rock full of faults and fissures, &c.) is quite completely broken up into smaller pulses moving in every possible direction. Thus fog bells and whistles, and indeed all other sounds, are heard further during cloudy and foggy weather, and during the night, when the earth is shaded from the sun's heat; and balloonists testify that during the night they hear terrestrial sounds more distinctly. A mixture of rapid currents, even if the liquid be homogeneous, has the same effect; so that the attempts made in 1870 during the siege of Paris to send sound signals through the waters of the Seine were quite unsuccessful, the range of distinct hearing being far less than in the quiet waters of a lake.—The nature of a pulse of sound is such that if two or more pulses meet under certain conditions they will interfere with each other so as to produce silence instead of sound at the point of their intersection. The echoes within rooms of regular symmetrical proportions do thus interfere with each other, and to a slight extent with the direct waves of sound, so that the loudness of the sounds perceived by the ear varies greatly

with a change of position of a few feet. In order that reflected waves should thus produce silence, they must have travelled over paths differing in length by some odd multiple (3, 5, 101, &c.) of a half of the wave length peculiar to the pitch of the sound in question. Because of the variety in the length of the waves that issue from the vocal organs, it follows that a point in an auditorium may be unfavorable to the perception of certain notes in the speaker's voice or in the music of an orchestra, yet favorable to the perception of all others. In the study of the acoustic properties of public halls, Langhans (1810) and Orth (1871) have made valuable investigations. Some of their results are as follows: 1. The phenomena of interference are of minor importance as disturbing elements, while the principal evil to be avoided is the confusion and repetition of echoes. 2. It is less important to provide for the concentration of the sounds of the speaker's voice than for the suppression of all echoes. 3. A difference of path between the direct and the reflected sounds of from 15 to 22 ft. does not disturb and may even assist the hearing; a difference of from 185 to 215 ft. may be disregarded because of the comparative feebleness of the echo; a difference of 30 ft. is to be avoided, as being the most annoying. 4. Low roofs, as in theatres, are advantageous; high ceilings, as in Gothic churches, are of no decided advantage, and may help to produce undesirable echoes. 5. If wood panelling or plaster is introduced to deaden the echo, it is most important to attend to the backing by which the panels are fastened to the walls.—The pitch of an echo, like that of any sound, depends on the rapidity with which the individual pulses encounter the tympanum. When these pulses follow each other at the rate of from 10 to 16 per second, the ear ceases to be able to separate one from another, and the whole are merged in an apparently continuous humming noise or a musical note of low pitch; the pitch increases directly as the rapidity of the pulsation. If the pulses occur at irregular intervals, and with unequal intensities, a noise or a sense of confusion is produced. These principles find an application in the case of sound reflected from a series of plane reflecting surfaces, such as the palings of a fence, a row of square pillars, &c.; in these cases the original sound does not appear to be echoed, but instead thereof we hear a musical note, generally of high pitch, lasting for a second or two only, and rapidly diminishing in intensity; if the observer be in motion, the individual echoes reach his ear more or less rapidly than if he be stationary, thus producing a corresponding change in the pitch. Lord Rayleigh has shown that a group of bodies whose dimensions are quite small in comparison with the wave lengths of sound reflect the first harmonic or octave 16 times more powerfully than the fundamental tone; and in general the reflecting or diverting power of

small obstacles varies inversely as the fourth power of the wave length. When therefore a composite note, such as those of the human voice, is echoed back from such a group of objects, the notes of higher pitch will be returned in far greater proportion, and the general effect will be that the echo appears to be pitched in a higher key than the original. On the other hand, the direct wave, being shorn of its higher elements, will appear to be duller than the original, and may appear to have fallen an octave, since it is well known that pure tones are apt to be estimated too low. It is therefore evident that the sounds from any musical instrument, if echoed from a proper group of surfaces, will be shorn of the lower or fundamental tones and appear pitched a third, a fifth, &c., higher, as in the harmonic echoes above enumerated; while on the other hand, if echoed from a plane surface studded with small obstacles, they may be deprived of those higher rates of vibration that constitute the peculiarities of timbre or quality, and be reduced to their fundamental vibrations, whereby the notes from the various instruments are made to sound more like each other, as in the case quoted above from Tyndall. If, on the other hand, a pure tone be echoed from a sounding board or other elastic surface, there are induced in the latter such subordinate harmonic vibrations as it may be capable of, and these communicated to the air return to the ear along with the fundamental note, thus producing an effect as to quality of tone precisely the reverse of that observed by Tyndall.

**ECHO**, in Greek mythology, an oread nymph, daughter of the earth and air. While Jupiter waned with the other nymphs, she detained Juno with endless speech. As soon as Juno understood the device, she changed the nymph into an echo. Thus transformed, Echo withdrew to the banks of the Cephissus, not far from Athens, at the foot of Mt. Pentelicus, and became so desperately in love with Narcissus, son of the river god, that she followed him through the forests, in the chase, to the darkness of grottoes, and to the borders of fountains, and ever repeated in solitary places the name of her beloved. Narcissus disdained her passion; and she retreated into the depths of the woods, and pined away in secret. Only her plaintive voice was always heard in the distance, and it was said that her bones were changed into rocks, and her voice alone remained. She was avenged by Nemesis, who inspired Narcissus with a passion for himself.

**ECHOLS**, a S. county of Georgia, bordering on Florida and intersected by the Allapaha river; area, about 400 sq. m.; pop. in 1870, 1,978, of whom 465 were colored. The surface is level, the soil sandy. The chief productions in 1870 were 41,814 bushels of Indian corn, 7,947 of oats, 16,957 of sweet potatoes, and 457 bales of cotton. Capital, Statenville.

**ECIJA** (anc. *Astigi*), a city of Andalusia, Spain, on the Genil, in the province of 47 m.

E. N. E. of the city of Seville; pop. about 30,000. There are several fine residences in the city, a pretty theatre, a handsome square, and a charming promenade outside the town. In the Plaza de Toros some of the best bull fights in Spain take place. From its excessive heat the town is called the *sartenilla* (frying pan) of Andalusia. Its industry consists chiefly in the manufacture of woollens, linen, silk, and oil, and tanning. *Écija* was for a long time in the middle ages an important border town between the Moors and Christians, and the scene of many romantic adventures. Inscriptions and relics of antiquity still exist here.

**ECK**, or **Eckius**, **Johann Mayr von**, a German theologian, born in Eck, Swabia, Nov. 13, 1486, died in Ingolstadt in 1543. The son of a peasant, he acquired, by a profound study of the Christian fathers and the scholastic philosophers, an erudition and skill in disputation which Luther and Melancthon much admired. He was doctor of theology, canon of Eichstädt, and vice chancellor of the university of Ingolstadt, when in 1518 he appeared as an adversary of Luther by his notes upon the theses of that reformer. He met Luther and Carlstadt in the conferences at Augsburg and Leipsic, but failing to convince them, he went to Rome to urge severe measures against them. He returned to Germany with a papal bull of condemnation, but at Leipsic the people had so warmly embraced the new doctrines that he saved himself from violence only by retreating to a convent. He subsequently labored fruitlessly to reunite the divided church.

**ECKERMAN**, **Johann Peter**, a German author, born at Winsen, Hanover, in 1792, died in Weimar, Dec. 3, 1854. He assisted Goethe in his last edition of his complete works, and was named in his will editor of his literary remains, which were published in 1832-'3. In 1839-'40 he edited Goethe's works complete in 40 volumes; but the work which won for him much reputation was his *Gespräche mit Goethe* (3 vols., Magdeburg, 1836-'48). Extracts of this work were translated into many foreign languages, including the Turkish. The first English translation was made by Margaret Fuller, and published at Boston in 1839. Another English translation by John Oxenford appeared in London in 1850.

**ECKERSBERG**, **Christoph Wilhelm**, a Danish historical, marine, and portrait painter, born near Apenrade, Jan. 2, 1783, died in Copenhagen, July 22, 1853. He studied at the Copenhagen academy, and in Italy and France. Rising rapidly to considerable distinction, he was in 1817 made an academician, and almost immediately a professor at the academy. Among his important works are his picture of Moses commanding the Red sea to close after the passage of the Israelites, "Death of Baldu," a scene from Oehlenschläger's "Axel and Walpurga," and "Roadstead of Helsingfors."

**ECKFORD**, **Henry**, an American ship builder, born in Irvine, Scotland, March 12, 1775, died

in Constantinople, Nov. 12, 1832. He served his apprenticeship in Quebec, and in 1796 removed to New York, where he introduced many important changes in the art of ship building. During the war of 1812 he built a fleet of vessels of war for the United States on the lakes with great rapidity, cutting the timber from the forests and transporting the equipments from the seaboard. After the war he constructed the Robert Fulton, which made in 1822 the first successful voyage by steam to New Orleans and Havana. He was for a time naval constructor at the navy yard in Brooklyn, and he also built war vessels for various European and South American powers. In 1831 he built a sloop of war for Sultan Mahmoud, and was invited to enter his services as naval constructor. He took up his residence in Constantinople, organized a navy yard there, and laid the keel of a ship of the line, but did not live to see it completed.

**ECKHART, Meister** (master), the father of German mysticism, born probably in Strasburg in the middle of the 13th century, died probably in Cologne about 1328. He studied theology and philosophy in Paris, became a Dominican friar in Rome, and afterward provincial of the order in Germany, vicar general for Bohemia, and prior in Frankfort-on-the-Main. His attempts to reform the Dominican convents and his exalted mysticism caused him to be suspected of heresy, and in 1327, while he was in Cologne, Archbishop Henry substantiated the charge before a tribunal of the inquisition. A papal bull was issued against his writings, March 27, 1329, which declared that he had recanted before his death. This alleged recantation merely consisted, according to a document of Feb. 13, 1327, still extant, in his protest against the malicious interpretation of garbled passages from his doctrines, which in his opinion had never transcended the bounds of orthodoxy. Tauler, Suso, and other eminent men were among his disciples, who cherished his memory as a profound thinker, a lucid expounder of the most abstruse speculation, and one of the best German prose writers. The second volume of Pfeiffer's *Die Deutschen Mystiker des 14. Jahrhunderts* (Leipzig, 1857) contains his preserved sermons and treatises. See also Bach's *Meister Eckhart, der Vater der deutschen Speculation* (Vienna, 1864).

**ECKMÜHL, or Eggmühl**, a village of Bavaria, on the river Grosse Laber, 13 m. S. E. of Ratisbon, memorable for the great victory gained there by Napoleon over the Austrians under the archduke Charles, April 22, 1809. Marshal Davoust, having especially signalized his valor during the engagement, was created prince of Eckmühl. This battle, and the minor actions of Abensberg (April 20), Landshut (21), and Ratisbon (23), which closely preceded or followed it, cost Austria 25,000 men, and obliged the archduke Charles to retire into Bohemia, and to leave open to Napoleon the highway to Vienna.

**ECKSTEIN, Ferdinand**, baron d', a French publicist, born of Jewish parents in Denmark in 1790, died in November, 1861. He became a convert to Catholicism, took part in the campaigns of 1812-'14, held various offices under the Bourbons in France, who conferred on him the title of baron, and retired from public life in 1830. From 1826 to 1829 he conducted a periodical, *Le Catholique*, in which he advocated the religious views of De Maistre and De Bonald. Among other works he published *De l'Espagne, Des Jésuites, De l'Europe, and Des sources de l'opinion publique en Europe*. He was an orientalist, and at his death was engaged on a *Histoire des origines de l'humanité*.

**ECCLECTICS** (Gr. ἐκλέγεσθαι, to select), a class of ancient philosophers who professed to select whatever was good and true from all the other philosophical sects, that they might combine it in a new system. They held Plato in the highest esteem, but did not hesitate to add to his doctrines whatever they thought conformable to reason in the tenets of the other schools, or to reject whatever they disapproved. The eclectic system is supposed to have originated with Potamon of Alexandria, a Platonist; it flourished at Alexandria about the beginning of our era; and it reached its perfection under Ammonius Saccas, who blended Christianity with his views, and founded the Neo-Platonic sect of the Ammonians toward the end of the 2d century. The moral doctrine of the Eclectics was, that the mind of man, originally part of the Divine Being, having fallen into darkness and defilement through its connection with the body, is to be gradually emancipated from the influence of matter, and rise by contemplation to the knowledge and likeness of God; and that this result, which is the great end of philosophy, is to be attained through abstinence, voluntary mortification, and religious exercises. In the infancy of this school, not a few professors of Christianity were led to think that a coalition might advantageously be formed between its system and that of the gospel. The only consequence was the corruption of the doctrines of the New Testament, by their mixture with pagan ideas and opinions. One of the most eminent Eclectics was Proclus, an edition of whose works was prepared by Victor Cousin (6 vols., Paris, 1820-'27), who used the term Eclecticism in a different sense to represent his own philosophical system.

**ECLIPSE** (Gr. ἐκλείπειν, to fade away, vanish), the obscuration of one celestial body by another, whether by intercepting the light coming from it or the light illuminating it. Eclipses of the former kind are sometimes called eclipses, sometimes occultations, and sometimes transits. Thus when the moon hides the sun's face wholly or in part, the phenomenon is called an eclipse of the sun or a solar eclipse; but when the moon conceals a star, the phenomenon is called an occultation of the star. Again, when Jupiter or Saturn hides one of his satellites by intervening between the earth and that

satellite, the event is called an occultation of the satellite; but when a satellite of Jupiter hides a portion of the planet, a transit of the satellite is said to be in progress; and when Venus or Mercury hides a portion of the sun's face, a transit of Venus or Mercury is said to be in progress. Events of the second kind are called eclipses in nearly all cases, but occasionally the transit of a shadow. Thus if the earth's shadow falls upon the moon, so as to obscure her face either wholly or partially, the phenomenon is called an eclipse of the moon; so also if the shadow of Jupiter or Saturn obscures a satellite of either planet, the phenomenon is called an eclipse of the satellite; but when the shadow of a satellite of either planet falls upon the planet, a transit of the shadow is said to be in progress.—For the principal phenomena presented during a solar eclipse, see SUN. It is only necessary to mention here that, owing to the various distances of the sun and moon, a solar eclipse may be total or annular when central; that is, either the whole face of the sun may be concealed, or a ring of the sun's light may remain visible all round the disk of the moon. When the eclipse is not central, so that at the moment of greatest obscuration a crescent-shaped portion of the sun remains visible, the eclipse is said to be partial.—In lunar eclipses the shadow of the earth seldom falls very nearly centrally upon the moon; yet owing to its great breadth at the moon's distance, the moon is often totally immersed in the shadow. When this happens the phenomenon is called a total lunar eclipse. When the moon passes only in part into the earth's true shadow the phenomenon is called a partial lunar eclipse. As the earth's shadow is surrounded by a penumbra, it occasionally happens that the moon passes partly within the penumbra without reaching the true shadow. Such phenomena have been called penumbral lunar eclipses. It might be supposed that when the moon is totally immersed in the true shadow of the earth she is totally obliterated from view; but this seldom happens. Usually the moon in the heart of the earth's shadow presents a dark red or copper-colored disk. It is believed that the light which thus illuminates her is sunlight which has undergone refraction by the earth's atmosphere. Indeed, it is demonstrable that if the moon is centrally eclipsed, even when she is nearest to the earth, a visual line from any point of the moon tangential to the earth's globe would be so bent by refraction in its passage through the earth's atmosphere as to reach the sun's disk; so that an inhabitant of the moon would see a ring of reflected sunlight all round the earth's disk during one of these total eclipses. But this would not happen if all those parts of the terrestrial atmosphere which bordered on the earth's visible half were cloud-laden; and this is believed to be the reason why occasionally the moon disappears wholly from view when totally eclipsed.

**ECLIPTIC**, the great circle of the heavens along which the sun appears to travel in the course of a year. It is inclined at an angle of about  $23^{\circ} 28'$  to the celestial equator. The name is derived from the fact that the light of the sun or moon can only "pass away" when the moon is on or near the ecliptic. The ecliptic is divided by astronomers into 12 equal portions, each of  $30^{\circ}$ . These are called signs, and supply the means of indicating the annual progression of the sun. They commence with the point where the ecliptic crosses the equator passing from south to north. This point is called the first point of Aries, and is indicated by the sign  $\varphi$ ; and Aries extends  $30^{\circ}$  along the ecliptic eastwardly, that is, in the direction of the sun's motion, from this point. Then follow successively the signs Taurus  $\tau$ , Gemini  $\text{II}$ , Cancer  $\text{C}$ , Leo  $\text{L}$ , Virgo  $\text{V}$ , Libra  $\text{Z}$ , Scorpio  $\text{S}$ , Sagittarius  $\text{Z}$ , Capricornus  $\text{C}$ , Aquarius  $\text{A}$ , and Pisces  $\text{P}$ . These signs, whether regarded as ecliptical or zodiacal, are not identical with the corresponding zodiacal constellations, each of which, owing to precession, has been carried so far forward as to agree very nearly with the next sign. Thus the constellation Pisces corresponds very nearly with the sign Aries, the constellation Aries with the sign Taurus, and so on. The sun enters Aries at the vernal equinox, on or about March 21, Taurus on or about April 20, Gemini on or about May 21, Cancer on or about June 21 (the summer solstice), Leo on or about July 22, Virgo on or about Aug. 23, Libra on or about Sept. 23 (the autumnal equinox), Scorpio on or about Oct. 23, Sagittarius on or about Nov. 22, Capricornus on or about Dec. 21 (the winter solstice), Aquarius on or about Jan. 20, and Pisces on or about Feb. 19.

**ECUADOR**, a republic of South America, named from its situation under the equator. It lies between lat.  $1^{\circ} 50' \text{ N.}$  and  $5^{\circ} 30' \text{ S.}$ , and lon.  $69^{\circ} 52'$  and  $80^{\circ} 35' \text{ W.}$ , and is bounded N. by the United States of Colombia and Brazil, E. by Brazil, S. by Peru, and W. by the Pacific. The Ecuadorians assert their right to the province of Mainas, S. of the Marañon; but most geographers assign that river as the greater portion of the southern boundary, adopting for the northern a right line drawn from the northernmost mouth of the river Mira E. by S. to the Caqueta or Japurá, some 30 m. below the confluence of the Mesaí, the Caqueta itself forming the remainder of the boundary to lon.  $69^{\circ} 52' \text{ W.}$  The extreme length of the republic would thus be about 740 m. from E. to W., and the greatest breadth 520 m. from N. to S. The area, according to the best estimates, is about 252,000 sq. m., and that of the Galápagos islands 2,951, making a total area of 254,951 sq. m.—The coast presents a sinuous convex line, about 700 m. long, with a general bearing from S. W. to N. E. Principal among the numerous indentations is that formed by the gulf of Guayaquil, 80 m. wide, at the mouth of the river of the same name. Further northward



are the bays of Santa Helena, Callo, Carácas, Mompiche, and Pailon. Mompiche bay is S. of Cape San Francisco, and Carácas S. of Cape Pasado. Point Santa Helena, a rocky promontory, is the most westerly land in the republic; and the whole coast from that point to Punta Galera, 350 m. northward, including the sinuosities, is of the same character as the promontory. Besides the Galápagos, which will be treated under that title, Ecuador possesses numerous islands, most of which are in the immediate vicinity of the coast. The principal of these are Puná, at the mouth of the Ría de Guayaquil (the landing place of Pizarro in 1531 when on his way to conquer Peru), Santa Clara, La Plata, and Tumaco. Of the three ports, that of Guayaquil, sheltered by the island of Puná, is the most important; it is one of the best on the Pacific, and monopolizes the maritime commerce of the republic. Esmeraldas, on the Río Esmeraldas, has anchorage for ships of small draft. Manta is now abandoned to coasters.—No country in the world presents a more varied surface than that of Ecuador; about nine tenths of it is composed of snow-clad mountains, dense forests, and vast *Ulanos* or savannas. To the east extend interminable forests and immense plains, intersected by rivers, lagoons, and marshes, and interrupted by mountain ranges stretching from the Andes obliquely to the banks of the Amazon. To the west the country is covered with extensive forests, with less lofty mountains, and cut by rivers of lesser magnitude. The centre swells into two Cordilleras separated by a valley 300 m. long, with snow-covered peaks, ranking among the loftiest of the earth. The valley is remarkable as being, next to the basin of Titicaca, the centre of the most ancient native civilization of America. The Andes enter the republic by the mountain knot of Loja, where they separate into two chains parallel to each other and to the coast, traversing the state in a N. N. E. direction, until the chains again unite in the mountain knot of Pasto, near the northern limit. At two points transverse ridges link the two parallel chains together, dividing the large valley into three smaller ones, named severally, commencing at the south, Cuenca, Alausí and Ambato, and Quito. The first of these cross ridges occurs about lat.  $2^{\circ} 27'$  S., and takes its name from the trachytic range of Asuay, which attains an elevation of 15,440 ft.; and the second, the Alto de Chisinche, only 500 ft. above the surrounding plain, about lat.  $0^{\circ} 40'$  S. This latter ridge forms the Ecuadorian watershed between the Atlantic and Pacific. The elevation of the valleys varies from 8,500 to 14,500 ft., that of Quito having a mean elevation of 9,540 ft. None of the mountains bordering the southern valley, Cuenca, reach the line of perpetual snow. The principal summits are comprised between lat.  $2^{\circ} 27'$  S. and  $1^{\circ}$  N., the eastern range, or Cordillera Oriental, maintaining the greatest general elevation, although

Chimborazo, the culminating point of the system, 21,422 ft. above the sea, is in the Cordillera Occidental or western range. The other noteworthy peaks in the Cordillera Occidental are: Iliniza (17,380 ft.), Pichincha (15,924), Carihuirazo (15,920), Chiles (15,960), and Cumbal, about 1,500 ft. above the snow line, which in Ecuador is a little above 14,000 ft. The principal summits of the Cordillera Oriental are Cayambi (19,813 ft.), the only volcano on the globe immediately under the equator; Sara Urcu or Supai Urcu (17,276 ft.), 35 m. E. of Quito, forming part of a ridge known by the name of Guamani; Antisana, 35 m. S. E. of Quito (about 19,200 ft.), Cotopaxi (about 19,500), Llanganate (18,639), Tunguaragua (16,424), Altar (17,126), and Sangay (16,138). Nowhere in the whole system of the Andes are more colossal mountains than those on either side of the valleys of Quito and Ambato,  $2^{\circ}$  S. and  $0^{\circ} 15'$  N. of the equator. Many of these are volcanoes, a few being extinct, and the others in activity. The whole table land of Quito constitutes one vast volcanic hearth, the subterranean fire bursting sometimes from one and sometimes from another of the openings, which have generally been regarded as independent volcanoes. The country between the Andes and the Pacific is intersected by spurs detached from the western chain, and gradually sinking into low hills as they approach the coast, except the portion adjacent to the Ría de Guayaquil, which is a plain several miles in extent, and so low as to be inundated during the flood. Swamps prevail also in this region.—The Amazon, here called the Marañon, on the southern boundary, receives the waters of several tributaries taking their rise within the territory of Ecuador. The most important of these is the Napo, which, rising in the eastern declivities of Cotopaxi and Sincholagoa, holds a generally S. E. course through the plains of Oriente to its junction with the Amazon, a distance of about 600 m., receiving the Arajuno, Yasuní, Coca, Aguárico, Curaray, and other tributaries. It is navigable by steamers from its mouth to the confluence of the Coca, about 400 m.; above that point the natives navigate it in canoes. Orellana, the first European who navigated the Amazon, embarked on the Coca, a few miles above its junction with the Napo. The Pastaza has a course of 540 m., about 270 of which are navigable by steamers, and 60 more by small craft; it takes its rise in the same region as the Napo, and joins the Amazon in lat.  $4^{\circ} 35'$  S., lon.  $76^{\circ} 35'$  W. The upper part of this river is called Patate. The Santiago, flowing from the lakes Quinuas, Cajas, and Culebrillas, in the valley of Cuenca, maintains first an easterly and afterward a southeasterly course, and falls into the Marañon near the town of its own name, and in the vicinity of the falls of Manseriche; its length is 500 m., and it may be navigated by steam for 300 m.; it receives the waters of the Zamora and other important streams. Besides the foregoing,<sup>11</sup>



there are the smaller rivers Chinchipe, Morona, Tigre, and a few others, navigable for greater or lesser distances. N. of the Napo are the Putumayo and the Caqueta or Japurá, both of considerable magnitude, but neither wholly within the territory of Ecuador. The first enters it near San Miguel, and after traversing the northern portion of Oriente in a generally S. E. direction, flows through the Brazilian forests to the Amazon. The second constitutes part of the N. boundary line of the state. All the rivers on the W. side of the Cordillera Occidental hurry by briefer courses to the Pacific. The Guayaquil is formed by the union of numerous streams issuing from the mountains adjacent to Chimborazo, and falls into the gulf of Guayaquil; it is navigable as far as Babahoyo, 75 m., and receives the waters of the Baba and the Daule. The Mira falls into the sea by several mouths at the northern extremity of the coast; the Esmeraldas into the Ancon de Sardinas; the Chones and the Charapotó into Caracás bay; and the Jubones and the Tumbes into the bay of Tumbes. All these, except the Guayaquil, are only navigable by boats, rafts, and small craft. Ecuador has no lakes properly so called; but there are many lagoons, some in connection with the various tributary streams of the Marañon, others in the elevated table land formed by the eastern and western Cordilleras, and a few in the high plains of the Cordilleras. The Yaguarechoa, in the plains of Imbabura, is one of the largest. In the province of Guayas numerous lagoons are formed in the rainy season, which dwindle into stagnant pools in the dry months.—Little has been done toward the examination of the special structure of the equatorial Andes. The characteristic syenitic rocks and porphyries occur here in as great abundance as elsewhere in the Andine system; yet several important ridges and peaks are observed to be of trachytic formation. Chimborazo, Asuay, and many other mountains of either Cordillera, present the last named character; and extensive tracts in the vicinity of Sangay and Cotopaxi are covered with lava, pumice stone, and cinders; while ruined temples and causeways, the work of the incas, constructed almost wholly of freestone, attest the existence of this last in considerable quantities. Gold, silver, copper, iron, lead, zinc, and sulphuret of mercury occur in various parts. Gold is said to be washed down by most of the rivers descending from the eastern declivities of the Andes; but the gold mines of the elevated mesas of the Cordilleras were, in common with those of silver and mercury, long ago abandoned. At present there are few gold mines, and these only in the mountains near the coast. Antimony, manganese, sulphur, salt, coal, and petroleum are found. But the only productive mining operations are those of iron and copper.—The climate of Ecuador is as varied as the face of the country. In the wooded and marshy regions E. of the Cordilleras and in the

lowlands on the west it is hot and moist; while in the great valley between the eastern and western chains, the climate and temperature vary with the elevation of the plains, or their proximity to the mountains. There are but two seasons, summer and winter. The former, commencing in June and lasting till November, is the season of winds; and the latter, beginning in December and ending in May, is the rainy season. This regular succession of the seasons, however, is known only in the table land between the mountains, and on the plateaus along the declivities of the western Cordillera. Hail and snow storms are common in the elevated plains of the Cordilleras, and frosts destroy the unripe cereals. The direction of the wind changes with the localities. In the great inter-alpine valley, the prevailing wind is from the south, with an occasional norther; but in the more elevated regions the wind currents are almost constantly from the east, sometimes increasing to terrible tempests. In the coast region the south wind prevails in summer and the north wind in winter. In the latter season the copious rains at the head waters of the rivers cause them to inundate the surrounding districts. After the floods subside, the region is for some time covered with a pestilential marsh, which sends forth myriads of noxious insects. Fevers are prevalent during the wet season in the low country, which consequently has few inhabitants of European descent. The climate on the whole is salubrious, particularly that of the valley between the Cordilleras. Intermittent and other fevers are frequent in the coast region; but they are unknown in the highlands, and pulmonary consumption is rarely heard of. Elephantiasis is common at Quito.—In consequence of the equatorial position of Ecuador and its varying elevation, it has in close proximity all the productions of the tropical and temperate zones. In the plains of Quito are produced sugar cane, cotton, and maize, and higher up European cereals and fruits. The low lands produce cacao, coffee, sugar cane, rice, cotton, pepper, tobacco, India rubber, copal gum, vanilla, sarsaparilla, and the tropical fruits, among which are chirimoyas, granaditas, aguacates, plantains, mameys, guavas, and a variety of melons. Besides cinchona (the original home of which is the southern frontier of Ecuador, and especially the region around Loja), there is an immense variety of medicinal roots and plants. The pita or American aloe, and the species of grass called *pajon*, from which are made the so-called Panama hats, are among the most useful productions of the country. The great forests present inexhaustible quantities of timber suitable for every purpose in ship building, house carpentry, and cabinet work. Among the woods are the guachapeli, which hardens in water or in contact with the humidity of the atmosphere, and the *sindicaspí*, which burns freely when fresh cut. Agriculture is in a low condition; the imple-

ments of the husbandman of to-day differ little from those used by his forefathers at the time of the conquest.—Three species of *felidae* infest the great forests at the east, the jaguar, puma, and a kind of wild cat. There are also bears, tapirs, several varieties of wild hogs, deer, hares, rabbits, squirrels, armadillos, and monkeys. Among the reptiles are caymans, lizards, adders, and vipers; the great boa, the rattlesnake, coral, equis, tayas, and tigre. Mosquitoes and other noxious insects infest the marshes and coast region. The shores abound in turtles. There are two or three species of condor. Of fishing birds, the principal are the albatross, sea gull, and kingfisher; and there are cranes and ducks of many kinds, pheasants, partridges, pigeons, and a host of others. In the forests are the nightingale, blackbird, thrush, corregidor, and a variety of parrots, parroquets, and other birds of brilliant plumage. The rivers afford an abundant supply of excellent fish. Salt-water fishing is carried on to a considerable extent. Horses, asses, and mules are abundant. The rearing of cattle and sheep forms an extensive industry; and numerous herds of llamas pasture on the páramos.—Manufacturing industry is not extensive in the interior, and still less so on the coast. The natives of the highlands make furniture, saddles, earthenware, and cotton and woollen goods. In Otavalo and elsewhere are factories for linen cloths, damasked quilts, carpets, and drapery for beds, highly esteemed for the delicacy and durability of their colors. About 6,000 ponchos are made monthly at Cotacache, Hatuntaqui, and Guano. There are a few silk-weaving establishments, for which the raw material is mostly imported from France; but some attempts have lately been made to acclimatize the silkworm, which are likely to prove successful. Gold lace is manufactured at Quito, where the women make fine embroidery, needlework, and lace. The manufacture of jipijapa hats constitutes an important industry; some of the hats bring \$40 on the spot where they are made. Large quantities of cheese are made for exportation. Numerous sugar mills are in operation, as also tanneries and iron foundries. Cuenca has many sugar refineries, and is celebrated for its hams and sweetmeats. In Esmeraldas and Guayas immense quantities of cacao are prepared, that of the latter province being among the most esteemed in America. Rum is made from the juice of the sugar cane, and chicha from the yuca and other plants. The production of indigo bids fair to become a source of wealth. Ropes, mats, sackcloth, hammocks, and other articles are made from the fibre of the pita or American aloe. Ship building is carried on to a limited extent at Guayaquil. The implements employed in the foregoing manufactures are for the most part very imperfect; but some of the factories, especially those for cotton, are fitted with American machinery.—The leading articles of export from Ecuador

are cacao, hats, tobacco, cascarilla, leather, India rubber, timber, cundurango, and precious metals and stones. The export trade has been steadily increasing for the last few years; and the value of the exports in 1871 was \$3,045,684, distributed as follows: cacao, \$1,707,400; cascarilla, \$92,102; hats, \$74,256; India rubber, \$693,376; cotton, &c., \$30,816. There were exported in the same year 1,700 quintals of cundurango; and in 1870 precious metals and stones to the value of \$681,280. The imports consist chiefly of manufactured goods, principally from Great Britain, the value of which in 1870 was \$285,040. Cotton fabrics from the same country to the value of \$64,505 were imported in 1871. The total value of the imports is about \$2,500,000 per annum. Some coarse cotton goods are imported from the United States; wines, liquors, cloths, fancy articles, glass, chinaware, hardware, cutlery, &c., from England and France; and, owing to bad mills and worse roads, flour from Chili, and lard from the United States, have to be imported, while wheat and lard are exported from the high lands. The number of vessels which entered the port of Guayaquil in 1870, inclusive of 66 British packets, was 125, with an aggregate of 55,310 tons. There is an important coasting trade between the ports of the republic and those of Chili, Peru, and Colombia.—Hitherto the roads of Ecuador have been among the rudest in South America, and especially those from the coast to the interior; the only one worthy of the name of highway being that from Quito to Bogotá in Colombia. Three roads lead from Quito to the Amazon, and several from the more important cities of the highlands to those on the coast. All are extremely bad, even in the dry season, and become impassable in the wet. The roads to Guayaquil are mule paths; but those to the other seaports have to be traversed on foot. The government has recently decided to build suitable roads, of which some are in process of construction. A cart road, the first in the republic, has been finished as far as Sibambe, where it will unite with the railway of Milagro, soon to be undertaken by the government. Other railways are projected. Steamers already ply between Guayaquil and Babahoyo. There are three joint-stock banks in Guayaquil, and many private banking houses. The national bank was abandoned in 1872 in consequence of an unfavorable banking law passed in 1871.—Ecuador is divided into 13 provinces, which with their respective capitals are as follows:

PROVINCES.	CAPITALS.	PROVINCES.	CAPITALS.
Asuay.....	Cuenca.	Loja.....	Loja.
Chimborazo.....	Riobamba.	Los Rios.....	Babahoyo.
Esmeraldas.....	Esmeraldas.	Manabi.....	Portoviejo.
Galápagos.....	Albemarle.	Oriente.....	Archidona.
Guayas.....	Guayaquil.	Pichincha.....	Quito.
Imbabura.....	Ibarra.	Tunguragua.....	Ambato.
Leon.....	Latacunga.		

The population, according to the census of 1854, was 1,065,500; to which may be added 517,824 for the increase during 18 years, at the

mean annual rate of  $2\frac{1}{6}$  per cent., as computed by Villavicencio, and 200,000 savages inhabiting the province of Oriente; making a total population of 1,783,324 at the end of 1872. The chief towns are Quito, the capital (pop. about 70,000), Cuenca (32,000), Guayaquil (26,000), and Riobamba (20,000). The population consists of six classes: whites, Indians, cholos or mestizos, negroes, mulattoes, and zambos. The whites, who are the ruling class although comparatively very few, are almost exclusively descended from the early Spanish colonists, and constitute a species of aristocracy. As a rule they have preserved their European blood in tolerable purity, although here and there coarse black hair, particularly among the females, reveals the Indian element. They are shrewd, intelligent, generous, hospitable, and distinguished by extreme suavity of manner, but are averse to every species of manual labor. The few white creoles engaged in commerce or industrial pursuits are infected with a mutual distrust which damps or precludes all spirit of enterprise. The Indians are divided into 11 great families, each subdivided into numerous tribes. The Quitus, by far the most numerous, are the direct descendants of one of the most civilized aboriginal races of the continent. At the time of their subjugation by the Peruvian conqueror Huayna Capac, they constituted a powerful kingdom, and had attained a considerable degree of proficiency in some of the fine arts, such as architecture and painting. The victorious inca divided the kingdom of Quito into provinces, under the charge of military governors chosen from his own army. Many modern writers confound the Quitus with the Peruvians, deceived by the similarity between the two languages. The other families are the Cayapos, Colorados, Jivaros, Záparos, Anguteros, Encabellados, Orejones (or "Big Ears," so named from their habit of distending the lobes of the ears by inserting large disks of wood), Avijiras, Santa Marias, and Cofanes. Each of these families has a language of its own, though some of them speak the *lengua general*, or Quito, and Spanish. A few of them have fixed habitations, profess Christianity, and have fairly entered upon the career of civilization, although little attention has been paid to their education. The so-called free Indians are mule drivers, guides, and the like, a very small number being engaged in industries on their own account. Yet they may be said to be the husbandmen, herdsmen, miners, and even the manufacturers of Ecuador. They weave cotton and woollen stuffs, make the far-famed jipijapa or Panama hats, manufacture quilts and carpets esteemed for brilliancy and durability of color, and produce the best earthenware on the southern continent. Their skill as engineers is attested by their rope bridges, spanning rivers and chasms; and as mariners they are noted for their rafts or *balsas*, on which they navigate

the rivers, and not unfrequently perform long sea voyages. Their dwellings are hovels, made in the lowlands of a sort of wild cane, and covered with palm-leaf; and in the highlands, of mud thatched with rushes. Slavery no longer exists nominally; but the planters hire the Indians at insufficient wages, and then grant them advances in order to have the right to retain them in virtual bondage. These Indians are called *concertados* or *gañanes*. Some of the families are independent, roaming along the banks of the great rivers E. of the Andes, subsisting by hunting and fishing; while others cultivate maize and other plants, which, with meat and a poison used on arrows, they barter for tools, ornaments, and other commodities. The cholos, from the union of white and Indian, number about 900,000, and constitute the chief element of the population. Here, as elsewhere, they are more comely than the pure-blooded Indians. A large portion of the retail commerce is in their hands; they are also shoemakers, tailors, carpenters, and blacksmiths, and not a few of them acquire distinction in the various liberal professions. The negroes, whose number is small, live for the most part in the seaports and along the coast; their occupations are analogous to those of their class in other American countries. Almost the entire population of Esmeraldas is composed of mulattoes. The zambos, a mixture of Indian and negro, are chiefly found in the small seaports of the north. The Ecuadorians are all fond of music and amusement. The chief pastime of the whites and cholos is bull fighting; gambling is common to all classes, and drunkenness is the besetting vice of the Indians. —The present constitution of Ecuador was framed in 1845, and has twice undergone modifications: once by the national assembly at Guayaquil in 1852, and again by the regular legislative body in 1853. The form of government is republican, and the supreme power is divided into executive, legislative, and judicial. The executive power is vested in a president, elected for four years; the present executive, however, has been elected for six years. The legislature consists of a senate and a chamber of deputies, the first composed of 18 members and the second of 30, both elected by universal suffrage. The congress assembles annually on Sept. 15, at Quito. The nomination of the president takes place indirectly by 900 electors returned for that purpose by the people. At the same time the electors appoint a vice president, who in certain cases may be called upon by congress to take the place of the president before his term of office has expired. The president is assisted by three ministers (of the interior, of foreign affairs and finance, and of the army and navy), who, with the president and vice president, are responsible to the congress. The president has no power of veto, nor can he dissolve, shorten, or prorogue the sessions of congress. The judicial power rests in a supreme and superior courts, with parochial

judges, commercial judges, and municipal alcaldes. Criminal cases only are tried by jury. Capital punishment is inflicted by shooting. There being no penitentiary, offenders are condemned to labor on public works. In trials by jury, witnesses are examined, not by the attorneys, but by the judges; and if a witness fails to appear, his original deposition may be read even in criminal cases. A petit jury consists of nine members.—Nearly one half of the revenue is derived from the customs receipts. These were in 1865, \$417,697; in 1866, \$560,916; in 1867, \$565,382; in 1868, \$567,193; in 1869, \$663,356; in 1870, \$1,037,247; and in 1871, \$1,097,151. The total revenue in 1870 amounted to \$1,451,096, and the expenditure to \$1,119,737. Through increased imposts and the undertaking of public works, the revenue for the first half of 1872 was raised to \$1,510,072, and the expenditure to \$1,446,737. By a tariff law which took effect Jan. 1, 1872, excessive duties are laid upon many of the most indispensable articles of import. Articles for agricultural and educational purposes are admitted free of duty; firearms and all commodities of war are absolutely prohibited; and the publication, introduction, and sale of books and prints offensive to religion and good morals are prohibited. The foreign debt in 1865 was \$5,634,332; the home debt \$2,214,773. For some years past Ecuador has suspended payment of both debt and interest. English bondholders in 1873 complained of this, and were assured that one fourth of the customs receipts would at an early day be applied toward the liquidation of their claims. In 1863 there were a university and 310 schools, attended by 14,000 pupils. In 1873 the number of schools was nearly doubled. An academy of arts and sciences and a school of agriculture were to be established in Quito, and the advantages of the Guayaquil normal school were to be extended to Indian children. In 1872 prospectuses were issued for a school of obstetrics and one of sculpture to be opened in Quito under the direction of European professors. The course of teaching in the primary schools embraces reading, writing, arithmetic, and religion; in the higher schools, Latin and sometimes Greek. The university course comprises the Spanish language and literature, Latin, Greek, law, medicine, &c. The income is small and the salaries of the professors very low. The established religion is the Roman Catholic, and no other is tolerated in public. There is an archbishop at Quito, and bishops at Cuenca and at Guayaquil.—After the conquest of the inca dominions (see PERU, PIZARRO, and QUITO), the kingdom of Quito was made a presidency of the viceroyalty of Peru, and remained under Spanish rule from 1533 to 1822. It was one of the most productive of the Spanish colonies. In 1809 it revolted, and after many fruitless struggles achieved its independence by the battle of Pichincha, May 22, 1822. The ter-

ritory was incorporated into the republic of Colombia, on the disruption of which in 1831 it became an independent republic under the name of Ecuador. But a series of civil wars ensued, lasting almost without intermission for more than 20 years. In 1852 a quarrel arose with Peru, whose government was accused of openly favoring a revolutionary expedition under Gen. Flores against Ecuador. Desultory hostilities continued for six years, and in 1858 Guayaquil was blockaded by sea and land. The contest was terminated in August of that year. In September, 1859, President Robles was compelled to quit the country, and in the same year Guayaquil was almost totally destroyed by fire, and Quito laid in ruins (March 22) by an earthquake. In 1862 Guayaquil again suffered from a conflagration. Several important improvements were accomplished about this time, among which were the adoption of the French metrical system, the construction of a road and later of a telegraphic line from Guayaquil to Quito, and the paving of Guayaquil and supplying it with gas and water. In consequence of the interference of Mosquera, president of New Granada, who was endeavoring to bring about the reconstruction of the Colombian republic, Ecuador declared war against him, Nov. 20, 1863. The Ecuadorian army, under Flores, was completely routed, with the loss of all its baggage, 1,500 killed, and 2,000 prisoners; these, however, Mosquera released on their promise not to serve again in that war, and signing a petition in favor of the Colombian republic. Garcia Moreno, elected president in 1861, tendered his resignation March 23, 1864; but it was refused by the assembly. An unpopular measure of Moreno's was the concluding a concordat with the see of Rome, which gave the care of public education to the priests, and restricted the toleration of creeds hitherto enjoyed. He was forced to revise and modify the measure. He assumed the dictatorship Aug. 30, 1864, and perpetrated many cruelties in his efforts for the prevention of civil war. Don Geronimo Carrion was elected president in May, 1865, and was inaugurated in August following. In January, 1866, the government joined with Peru and Chili in an alliance against Spain, and banished all Spaniards. Carrion, whose administration had become unsatisfactory to the congress, was censured, and resigned in November, 1867. Congress in its next session revoked the power of the president to imprison persons regarded as dangerous to public order, set at liberty all who were in confinement, and recalled those who had been expatriated. By a decree of Oct. 25, 1867, Bolivians, Chilians, Peruvians, and Colombians may become naturalized without a previous term of residence. Ecuador was visited in August, 1868, by one of the most awful earthquakes on record. It was especially destructive in the province of Imbabura, completely overthrowing the capital, Ibarra; 30,000 persons are said to have perished.

About the beginning of 1869, Dr. Javier Espinosa being president, the government was overthrown by a revolutionary movement under Garcia Moreno, who succeeded in establishing himself as president. One of his first acts was to order all schools to be closed except those under the control of the Jesuits. Imprisonment for debt, unless under special circumstances, was abolished. Rafael Carvajal was elected president May 16, Moreno having resigned; but the latter was reelected for a term of six years before the end of 1869.

**EDDA** (Icelandic, ancestress), the name of two collections of ancient poems and legends of the Northmen, or early Scandinavians, from which is chiefly derived our knowledge of Scandinavian mythology. The Eddas, and in some instances the Sagas, were composed originally in Denmark, in Sweden, and doubtless also in Norway, where the language now known as Icelandic was longest preserved on the European continent. There is no doubt that the greater part of the Edda songs were in existence before the emigration to Iceland. They are generally assigned to the 8th, and a few of them to the 9th or 10th century. Judging from the unmixed pagan spirit that pervades them, it is probable that they belong to a much earlier age, and the primitive form of the language in which they have come down to us seems to warrant this opinion. The older Edda is well known under the title of *Edda Sæmundar hins Fróða*, "The Edda of Sæmund the Learned." What has been preserved of it consists of 39 poems, collected by Sæmund Sigfusson, an Icelandic priest, who died in 1133. A copy of this Edda on vellum, the best which is preserved, was found in Iceland by Bishop Brynjulf Sveinsson in 1643, and published under the above title (3 vols., Copenhagen, 1787-1828), with an excellent *Leicon Mythologicum* by Finn Arni Magnusson, the editor of the last volume. This copy is believed to date from the 14th century, and all the other manuscripts are more or less directly related to it. There are editions by Afzelius in Swedish (Christiania, 1818), by Munch (Christiania, 1847), and by Studach (Nuremberg, 1829). The different poems may be classed, according to the nature of their subjects, as mythological and legendary. The most remarkable in the former classification is that which bears the title *Völuspá*, the oracle of the *vala* or prophetess. It is a rapid exposition of the cosmogony of the Scandinavians, from the creation to the destruction of the universe. The *Grógaldr*, or magical song of Groa, purports to be a response to her son calling her from the grave to teach him the terms of magic. The *Vafþrúdnis-mál* narrates that Odin, desiring to test the wisdom of Vafþrúdnir, the wisest of the giants, sought his hospitality, and proposed a contest in questions and answers, the wager agreed upon being the head of the vanquished disputant. The giant recognized his guest at a question which Odin alone could put

and answer. The *Grimnis-mál* describes the 12 homes of the gods (the 12 signs of the zodiac). In the *Alviss-mál*, the dwarf Alvis goes to Thor and claims his daughter for his bride. The god agrees to give him his daughter if he will answer his questions. Alvis complies, but failing to watch for the break of day is changed into a stone. The *Hyndlu-liðs* tells of Freyja, who goes with Ottar to the vala Hyndla, that she may give him an account of his genealogy. The *Háva-mál*, the sublime discourse of Odin, is a collection of maxims, ending with a chapter wherein the god explains the mysterious power of the runes against various misfortunes. The *Hymiskviða*, or song of Hymir, describes a feast given by a sea god to his brother divinities. The *Hrafnagaldur-Óðins*, the song of the raven of Odin, describes the gods lamenting the approach of their last day. The class of legendary poems in the Edda is more abundant than the other. They narrate heroic days, and record the adventures of heroes who have been more or less truly identified with Dietrich, Sigfried, and Attila and his Huns, during their first inroads upon the provinces of Rome.—The peculiarity of the verse of the Edda songs consists in alliteration and in the number of rises and falls of the voice, without regard to the number of syllables. The peculiarity of the alliteration is that different vowels are considered to effect it, and that words beginning with *sk*, *st*, *sp*, must be harmonized with other words commencing with the same two letters. A stanza of the Edda song consists either of two equal parts of four half lines or two full lines, with two rises of the voice for each half line; or of two parts, each containing a proposition, and each formed of two half lines with two, and a longer line with two to four rises of the voice.—The younger or prose Edda, also called the *Snorra-Edda*, is ascribed to the celebrated Snorri Sturlason, who was born in 1178. It is a collection of the myths of the gods, and of explanations of the versification of the scalds or poets. It was gradually formed by the labors of several writers, although it usually bears the name of Snorri Sturlason alone. It was intended for the instruction of the young scalds, and shows that the old poetry of the Icelanders came to be cultivated as a learned art. The Edda of Snorri, obviously of less value than that of Sæmund, is principally worthy of attention in so far as it completes and aids the comprehension of the other. The first copy of it was found by Arngrim Jonsson in 1628, and the first complete edition was published in Stockholm in 1818, by Prof. Rask. The work had been imperfectly known in the edition of Resenius (Copenhagen, 1665), which made a careless use of the manuscript, often confounding the text with the notes of the scalds. The introduction, or *Formáli*, is a quaint compendium of Jewish, Christian, Greek, Roman, and Icelandic legend, illustrating the origin and chain of descent of the

Scandinavian race from the heroes of Troy. The *Gylfa-ginning* follows, and relates the visit of Gylfe, a Swedish king and magician, to Asgard, in order to observe at its fountain head the spirit of northern wisdom. An English translation of the first part of the prose Edda is contained in Mallet's "Northern Antiquities" (Bishop Percy's translation, new ed., London, 1847). The second part of the prose Edda, called *Bragar hättir*, represents Bragi, the god of poetry, at a feast given by Ægir, god of the sea, entertaining the celestial company with a narration of their own exploits. The epilogue, or *Eptimarli*, written by Snorri Sturlason or by a contemporary, is an attempted solution\* of the Edda fables by events of the Trojan war. At the end of the prose Edda we have the *Scalda*, a kind of *ars poetica*, or manual for the use of the young students of the art. The German song of the *Nibelungen* speaks of adventures and heroes like those of the Scandinavian poems; but while the German poem was probably written about the year 1207, the Scandinavian poems are known to have been earlier, probably by several centuries.—Among the several editions and translations of the older Edda prepared in modern times stands prominent for scientific accuracy and convenience of use, H. Lünig's *Edda, Ur-schrift mit Anmerkungen, Glossar und Einleitung* (Zürich, 1859). The best German translation of the two Eddas is by Karl Simrock (Stuttgart, 1851), which has passed through several editions. The best French translation is by Léouzon-Leduc (Paris, 1868). Baring-Gould's "Iceland, its Scenes and Sagas" (London, 1863), gives an entertaining account of the substance of the Eddas. Eirikr Magnussen and William Morris assert that they give in their "Story of the Volsungs and Niblungs, with certain Songs from the Elder Edda" (London, 1870), the first translation into the English language.

**EDDYSTONE ROCKS**, a reef in the English channel, 600 or 700 ft. long, off the coast of Cornwall, about 10 m. S. of the Rame head, entrance of Plymouth sound. They consist of three principal ridges, which are entirely covered at high water. The celebrated lighthouse on one of these rocks was begun in 1756 and finished in 1759. Its tower is 68 ft. high, and is surmounted by a lantern which is furnished with 16 powerful argand burners, with parabolic reflectors of silvered copper. The first lighthouse on these rocks was built in 1696-'9, of stone and timber. It was swept away in 1703, and another tower of wood was completed six years afterward. This was burned in 1755, and the present edifice was then commenced by the celebrated engineer John Smeaton. The material employed was Portland stone, encased in granite, partly quarried from the rock itself, into which the foundations were dovetailed. The violence of the swell at the lighthouse renders communication with the shore extremely difficult even in serene weather, and

the sea frequently rises above the light, the strong plate glass of the lantern having been more than once broken by the waves.—See

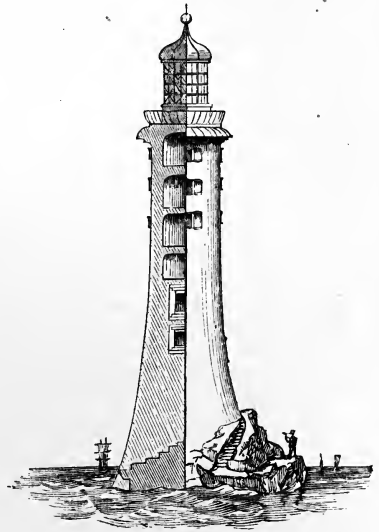

Eddystone Lighthouse (with section showing the interior arrangement).

"A Narrative of the Building of Eddystone Lighthouse," by Smeaton (4to, London, 1791).

**EDEN** (Heb., pleasure, delight; also *gan Eden*, garden of delight), the Scriptural name of the place where God placed Adam and Eve before the fall. In the Septuagint it is called Paradise, that is, a park or pleasure garden. It was watered by a river which, issuing forth, branched into four streams, named Pison, Gihon, Hiddekel (or Tigris), and Euphrates. No locality can now be fixed for the garden of Eden. The geographical indications in the book of Genesis are too vaguely expressed to enable us to determine with any approach to certainty which locality is meant. The most probable opinion seems to be that which assigns Eden a place somewhere among the mountainous regions of Armenia, where the rivers Tigris and Euphrates take their rise. Some writers, however, are of opinion that the garden of Eden is only a figurative expression, not intended to indicate any actual locality on earth. A few years ago Sir Henry Rawlinson, in a discourse before the royal society, asserted that he had deciphered the word "Eden" in cuneiform inscriptions among the ruins of Nineveh, and that it was a name given to Babylon.—Eden is also the Scriptural name of a territory, probably in the Euphrates valley, mentioned among the conquests of the Assyrians.

**EDENTATA**, a small group of mammals, elevated into an order by Cuvier, and associated rather by negative than positive characters; these are, a partial or total absence of teeth, the possession of very large claws embracing

the ends of the toes, and a general slowness of motion arising from the organization of the limbs. One group consists of strictly vegetable feeders, the *tardigrada* of Illiger, including the sloths (*bradypus*, Linn.); the other group is principally insectivorous, including the ant-eater (*myrmecophaga*, Linn.), the armadillo (*dasypus*, Linn.), the pangolin (*manis*, Linn.), the aard-vark (*orycteropus*, Geoff.), and the gigantic fossil *megatherium*. The term *edentata*, or toothless animals, is not properly applied to any of the group except the ant-eaters and the pangolins. The sloths are fitted for a life among the branches of trees, which they rarely leave unless in search of fresh food, and then in the slowest and most awkward manner; the ant-eaters dig up their insect food with their powerful claws, and entrap them on their glutinous tongues; the armadillos, with their hard external covering, pursue insects on the ground, dig after vegetables and roots, and eat even decaying carcasses. The skull in the sloth is very short and round, in the armadillo longer and pointed, and in the ant-eater much elongated; in the *megatherium* there is a return to the short and solid skull of the sloth, and this animal seems in many respects intermediate between the *tardigrada* and the true *edentata*. The spine varies in the length and firmness of its parts, according to the habits of the animal; the neck is long and capable of great rotation in the sloth, the two upper dorsals being so modified that they perform the functions of cervicals, with rudimentary ribs; the dorsal portion is very long, and contains more vertebrae than in any other mammalian group, viz.: 16 in the great ant-eater, 14 in the three-toed and 23 in the two-toed sloth; the ribs are remarkably broad, overlapping each other near the spine in some of the ant-eaters, giving thus great solidity to the chest and the necessary support for the digging fore limbs; the lumber vertebrae are broad, with strong spinous, transverse, and articulating processes; the caudal vertebrae are 7 or 8 in the sloths, 40 in the great ant-eater, 45 in the long-tailed pangolin, and at least 18 in the *megatherium*; the V-shaped bones on the inferior surface are well developed in the true *edentata*, and in the *megatherium*; the anterior bone of the sternum is considerably developed in the whole group, especially in the ant-eaters and armadillos. The pelvis in the sloths and the *megatherium* is wide and capacious, and the ilia very broad; in the true *edentates* it is elongated, with the acetabulum behind the middle, and the ilia are very long. In the latter the anterior limbs are formed for digging, and therefore the scapular arch is well developed, the humerus short and robust, with strongly marked processes for muscular attachments; a clavicle is present in the ant-eaters and armadillos, but absent in the pangolins; the forearm has so large an olecranon that the ulna is nearly or quite twice the length of the radius; the bones are robust,

and the hand is remarkable for the unequal size of the fingers, the middle one being in most of them much the largest; the peculiarities of the posterior limbs are less remarkable. Another reason for separating the *tardigrades* from the *edentates* is found in the digestive apparatus. In the former the teeth are simple, formed for bruising leaves and stems; the stomach is complicated, divided into numerous compartments by internal folds, somewhat like the stomach of ruminants; the large intestine is readily distinguished by its size from the small, and by their partial separation. In the *edentates*, the teeth when present are simple, more numerous, and formed for crushing insects; the stomach is far less complicated, and the division into small and large intestine is not well marked. The peculiar subdivision of the arteries of the limbs in the sloths is not required in the active and terrestrial *edentates*; and the investing armor of the armadillo and the pangolin would be equally unnecessary for the arboreal *tardigrades*. The *edentata* seem to establish the passage from the *unguiculata* to the *ungulata*, as the nails are greatly developed, and cover in a great degree the ends of the fingers. That which especially characterizes them is the absence of teeth in the anterior portion of the jaws, the dental apparatus being in most reduced to molars and canines.

**EDESSA. I.** An ancient city of northern Mesopotamia, the capital of the district of Osroëne; now Urfa, 84 m. S. W. of Diarbekir. Tradition ascribes its foundation to Nimrod, and supposes it to be on or near the site of Ur of the Chaldees. Sabaism is supposed to have been the religion of the early inhabitants, and in particular the worship of the goddess Atargatis. Under the Seleucidae it was called Callirrhoë, and under Antiochus IV. it took the name of Antiochia. In 137 B. C. it became the capital of an independent kingdom. The name or title Abgar or Agbar (the mighty) appears as that of its sovereigns, and its manufactories of arms were celebrated. Edessa was sacked by Trajan, on account of the equivocal conduct of its rulers during the wars of the empire against the Armenians and Parthians. In 216 it was made a Roman military colony by Caracalla, who was murdered there in the following year. It played an important part in the early Christian church, was the residence of St. Ephraem Syrus, had famous schools of theology and more than 300 monasteries, and was for many years the principal seat of oriental learning. It was taken by the Arabs shortly after the death of Mohammed, and in the time of the first crusade became a Christian principality under Baldwin I., brother of Godfrey de Bouillon. Baldwin ruled it from 1097 to 1100, purchased Samosata and several other places, and abandoned his fief for the crown of Jerusalem. Baldwin II., cousin of the preceding, reigned from 1100 to 1118, and was called in his turn to the throne of Jerusalem. Jocelin de Courtenay, the succes-

sor of Baldwin, was surnamed the Great by reason of his victories over the Saracens. Jocelin II., who reigned after him, was defeated by the sultan Nour ed-Din, who captured Edessa and exterminated the inhabitants. It was plundered by Tamerlane in 1393, subsequently annexed to Persia, and in 1637 fell into the

hands of the Turks, who changed its name to Urfa or Orfah. The modern town is large and well built, with a wall 7 m. in circuit, and 40,000 or 50,000 inhabitants, of whom about 4,000 are Armenians, 1,000 Jacobites, and the rest Turks, Arabs, Kurds, and Jews. Its grand mosque has considerable architectural merit; within it



The Castle of Edessa.

are several schools for the instruction of young men in religion and law. Among the antiquities are the ruins of a tower said to have been the palace of Nimrod, and the catacombs in the rock beneath. It derives great commercial importance from its position on the route between Aleppo and Kurdistan. **II.** The ancient capital of Macedonia (probably the same as *Ægæ*, now *Vodena*), situated on a branch of the river Ludias and on the Egnatian way, at the entrance of the pass leading from the mountain provinces into upper Macedonia, and also by another branch into Pelagonia and Lyncestis. The town was the cradle of the Macedonian dynasty, and even after the removal of the seat of government to Pella, in the plains below, Edessa was still the national sanctuary and the burial place of the kings. From its commanding position it continued to be of importance under the Roman and Byzantine emperors. Taken by Basil II., the conqueror of Bulgaria, it was strongly fortified under his reign (976-1025), and was called *Bodina*, whence the modern name. The modern town, which has few remains of antiquity, is 45 m. W. by N. of Salonica. The locality is still celebrated for its scenery.

**EDFOO** (Coptic, *Atbo*; anc. *Apollinopolis Magna*), a city of upper Egypt, about 2 m. from the left bank of the Nile, 50 m. S. S. E. of Thebes. It has about 2,000 inhabitants, and manufactories of earthenware. Here are remarkable ruins of two temples partly covered by sand, built by the Ptolemies after the ancient Pharaonic models. The entrance

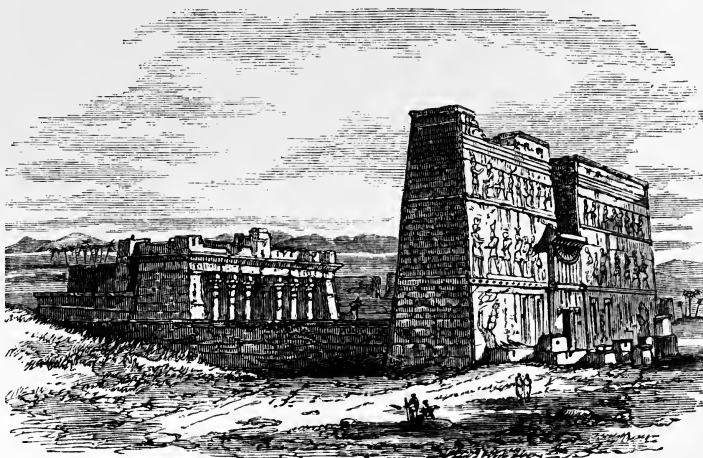

Ruins at Edfoo.

to the larger temple was by a gateway 17 ft. wide and 50 ft. high, between two truncated pyramids, 134 ft. long, 37 ft. wide at the base, and 114 ft. high. This entrance leads to a court 161 ft. long and 140 ft. wide, surrounded by walls; on each side is a row of pillars at some distance from the wall, the



space between being roofed over with stone, forming a covered portico about 35 ft. high. From the entrance to the court there is a gradual ascent to the portico of the temple, which is supported by 18 pillars in three rows, the whole height being 56 ft. Within the temple are several chambers, the last of which was the sanctuary, 33 ft. by 17, in which was placed the image of the god Num or Kneph, to whom the temple is generally supposed to have been dedicated. Champollion, however, supposed that it was dedicated to the worship of a triad, answering to the Greek Apollo, Aphrodite, and Eros. The whole is enclosed by lofty walls, and is 414 ft. long and 154 ft. wide. Every part of the temple and walls is covered with hieroglyphics, representing the daily progress of the sun through the heavens. This great structure is the most perfect example remaining of an Egyptian temple. The smaller temple, it is supposed, was dedicated to Horus, the son of Kneph; but Champollion thinks it was an adjunct of the great temple, and marks the birthplace of the third person of the triad. About three miles from Edfoo are many grottoes, excavated in the hillside, which probably served as the cemetery of the city.

**EDGAR**, an E. county of Illinois, bordering on Indiana; area, about 600 sq. m.; pop. in 1870, 21,450. It is drained by a branch of the Embarras river, and by Brulette and Clear creeks, affluents of the Wabash. The surface is nearly level, and occupied partly by prairies and timber. The soil is fertile. The Indianapolis and St. Louis railroad passes through it. The chief productions in 1870 were 260,643 bushels of wheat, 37,508 of rye, 2,107,615 of Indian corn, 290,679 of oats, 88,508 of potatoes, 36,638 tons of hay, 457,104 lbs. of butter, and 164,105 of wool. There were 10,294 horses, 6,666 milch cows, 20,935 other cattle, 42,786 sheep, and 38,654 swine; 3 manufactories of boots and shoes, 15 of carriages and wagons, 5 of furniture, 10 of saddlery and harness, 1 of sashes, doors, and blinds, 4 flour mills, 1 planing mill, and 3 saw mills. Capital, Paris.

**EDGAR**, a king of the Anglo-Saxons, son of Edmund I., born about 943, died in 975. He succeeded his brother Edwy about the beginning of 959, and made Dunstan his chief counsellor, whose influence continued paramount throughout his reign. While he was king England was disturbed neither by foreign invasions nor by the attacks of the northern pirates, and he was consequently surnamed "the Peaceful." He favored the monasteries, and especially contributed to increase the power of the Benedictines, about 50 monasteries of that order having been established during his reign. Having carried off a young lady from the convent of Wilton and made her his mistress, he was ordered by Dunstan, as a penance, to abstain for seven years from wearing his crown. His first wife was Elfreda, and his second Elfrida, the daughter of Ordgar, earl of Devonshire. William of Malmesbury, on the authority of a

Saxon ballad, relates that Edgar, having heard of the great beauty of Elfrida, sent his minister Ethelwold to ascertain whether, the reports were true. Ethelwold on seeing the lady was captivated by her charms, represented to the king that she was unworthy of his admiration, and married her himself. Edgar having discovered the deceit caused Ethelwold to be put to death and married Elfrida. The story has been made the theme of an English tragedy by William Mason, and of a French opera by Guillard. He was succeeded by his son Edward II.

**EDGAR ATHELING** (that is, Edgar the Noble), an Anglo-Saxon prince, in the second half of the 11th century. He was the grandson of Edmund Ironside by his exiled son Edward, and was born in Hungary. In 1057 he followed his father to England, after whose sudden death in 1066 he became heir to the crown, being the nearest relative to Edward the Confessor. Yet he was young and feeble, and presented no claim, while Harold and William of Normandy fought for the kingdom at Hastings. After that battle (1066) he was received at court by William, confirmed in the earldom of Oxford, which had been granted him by Harold, and treated with the greatest kindness. He accompanied the king in his visit to Normandy, but after his return, persuaded by the discontented Northumbrian lords, he took refuge with his followers in Scotland, and sought to lead a rebellion in Northumberland. Failing in this and in other enterprises, he returned to England in 1073, having previously rendered his submission to the king and received pardon. He was afterward engaged in a Scottish war to place a relative upon the throne of that country. The best result of his career was the introduction of the superior cultivation of the south into Scotland.

**EDGARTOWN**, the shire town and a port of entry of Dukes co., Mass., comprising Chappaquiddick island and the E. portion of Martha's Vineyard, about 75 m. S. S. E. of Boston; pop. in 1870, 1,516. The harbor is well sheltered, and has a depth of four or five fathoms. At the entrance is a lighthouse showing a fixed light 50 ft. above the sea, erected on a pier 1,000 ft. long. Steamers run daily to Wood's Hole, the terminus of the Falmouth branch of the Cape Cod railroad, and to New Bedford. In Edgartown is Wesleyan grove, the seat of a celebrated Methodist camp meeting, at which yearly in August about 20,000 visitors assemble. Near the camp ground, on bluffs 30 ft. high, overlooking the sea, the village of Oak Bluffs has recently been laid out, and has become a summer resort; it contains several hotels and numerous cottages of summer residents. The inhabitants are mostly engaged in navigation and fishing. For the year ending June 30, 1872, 25 vessels entered at the port and 16 cleared; 4 were engaged in the whale fishery, and there were 20 registered, enrolled, and licensed. The town contains the

county buildings, a town hall, a national bank, 8 schools (including a high school), a weekly newspaper, and Baptist, Congregational, and Methodist churches.

**EDGECOMBE**, a N. E. county of North Carolina, watered by Tar river, and by Fishing, Sandy, and Contenty creeks; area, about 600 sq. m.; pop. in 1870, 22,970 of whom 15,112 were colored. The soil is fertile and sandy. The surface is mostly level, and occupied in part by pine forests, from which quantities of turpentine are obtained. It is traversed by the Wilmington and Weldon railroad and the Tarboro branch. The chief productions in 1870 were 6,102 bushels of wheat, 488,800 of Indian corn, 48,573 of oats, 58,055 of sweet potatoes, 3,059 tons of hay, and 18,361 bales of cotton. There were 1,164 horses, 1,919 mules and asses, 1,403 milch cows, 3,339 other cattle, and 14,214 swine; 3 manufactories of carriages and wagons, 1 of cotton goods, 5 flour mills, and 7 saw mills. Capital, Tarboro.

**EDGEFIELD**, a W. county of South Carolina, separated from Georgia by the Savannah river, and bounded N. by the Saluda; area, 1,540 sq. m.; pop. in 1870, 42,486, of whom 25,417 were colored. It has a fertile soil and a moderately hilly surface. Water power is abundant, and there are numerous mills and factories. The Savannah river is navigable for steamboats to the S. part of the district, and by small boats a still greater distance. It is traversed by the South Carolina, the Charlotte, Columbia, and Augusta, and the Greenville and Columbia railroads. The chief productions in 1870 were 43,157 bushels of wheat, 412,259 of Indian corn, 77,370 of oats, 29,896 of sweet potatoes, and 17,553 bales of cotton. There were 3,134 horses, 3,459 mules and asses, 6,596 milch cows, 8,579 other cattle, 6,985 sheep, and 20,352 swine; 3 manufactories of carriages and wagons, 1 of cotton goods, 1 of printing paper, 1 of bricks, and 10 saw mills. Capital, Edgefield Court House.

**EDGEHILL**, a high ridge in Warwickshire, England, 12 m. S. S. E. of Warwick, noted as the scene of the first battle between Charles I. and the parliamentary forces, Oct. 23, 1642. On the side of the hill is cut the colossal figure of a horse, whence a valley below has been named the Vale of Red Horse.

**EDGEWORTH. I. Richard Lovell**, a British inventor and author, born in Bath in 1744, died at Edgeworthstown, county Longford, Ireland, June 13, 1817. He belonged to an ancient Irish family, and was educated at Trinity college, Dublin, and at Oxford. While at the latter university he ran away with a young lady of Oxford, married her, and settled near Reading. He had great mechanical ingenuity, and invented various contrivances, particularly a system of telegraphs, and a locomotive machine which carried with itself a movable railway. For these he was awarded two medals by the society of arts. In 1771 he went to France, and superintended part of

the works undertaken at Lyons to alter the course of the Rhône. In 1782 he took up his residence at Edgeworthstown and devoted himself to the cultivation of his estates. He was much interested in questions of education, and brought up his eldest son upon the principles inculcated in Rousseau's *Emile*. He was also interested in political economy, and labored for the improvement of the condition of his tenants. He took an active part in public affairs, was a member of the reform convention which assembled at Dublin in 1783, and entered the Irish parliament in 1798. He was opposed to the legislative union of England and Ireland, and when the Irish parliament gave its assent to that measure, he retired from political life. In 1804 he constructed for the government a telegraph between Dublin and Galway. He was placed upon commissions to revise the laws relating to education, and to investigate the best means of draining an extensive bog in Ireland. He was married four times, the last time to Honora Sneyd, who is supposed to have been affianced to Major André. Besides various parliamentary reports, he wrote, either alone or in conjunction with his daughter, among other things, "Professional Education," "Practical Education," and an "Essay on the Construction of Roads and Carriages."—See "Memoirs of Richard Lovell Edgeworth, Esq., begun by himself and concluded by his daughter" (2 vols. 8vo, London, 1820). **II. Maria**, an English authoress, daughter of the preceding, born at Hare Hatch, near Reading, England, Jan. 1, 1767, died at Edgeworthstown, Ireland (where she had resided since 1782), May 21, 1849. She was educated by her father, and became his assistant both in business affairs and in literary pursuits. The "Early Lessons," "Parent's Assistant," and "Essay on Irish Bulls" were the fruit of their joint labors. The views which she shared with him in regard to education were exemplified in "Harry and Lucy" and "Rosamond," commenced by him and completed by her after his death, and in "Frank," written by herself. The long series of excellent novels and tales for which she was celebrated began with "Castle Rackrent" (1801). Among the most noted of them are "Belinda," "Ennui," "The Absentee," "Patronage," "Harrington," "Helen," and "Ormond." All her writings are characterized by strong good sense, practical judgment, and high moral tone. Sir Walter Scott, whom she preceded as a novelist, was her warm friend and admirer, and she passed a fortnight with him at Abbotsford in 1823. A complete edition of her works was published in London in 1832, in 18 vols. 12mo, and they still continue to be reprinted.

**EDGEWORTH DE FIRMONT, Henry Allen**, abbé, the last confessor of King Louis XVI. of France, cousin of Maria Edgeworth, born in Edgeworthstown, Ireland, in 1745, died in Mitau, Russia, May 22, 1807. His father (Essex Edgeworth of Fairy Mount, whence Firmont)

having been converted to Catholicism, and removed to France, he received his education under the Jesuits at Toulouse and at the Sorbonne in Paris. He was the confessor of Madame Elizabeth, the sister of Louis XVI.; and at her suggestion he was invited by him at the time of his trial and condemnation to administer the consolations of religion. He attended the king during his last days, accompanied him to the scaffold, and was reported to have exclaimed at the moment of the execution, *Louis, fils de Saint Louis, montez au ciel*. The abbé himself always professed that he had no recollection of having uttered these words, and Lord Holland has shown that they were a royalist invention, made some time later. After the death of Madame Elizabeth he joined Louis XVIII. at Blankenburg in Germany, and went with him to Mitau. While caring for French prisoners at that place, he contracted a disease which occasioned his death. He left a volume of "Memoirs," edited in English by C. S. Edgeworth (London, 1815), and in French by Dupont (Paris, 1815). A collection of his "Letters" was also published at Paris in 1818.

**EDINBURGH**, a city of Scotland, capital of Edinburghshire, about 2 m. S. of the frith of Forth, 357 m. N. N. W. of London by road, and 399 m. by the Great Northern railway, in lat.  $55^{\circ} 57' N.$ , lon.  $3^{\circ} 11' W.$ ; pop. in 1871, 196,500. It is built principally on three parallel ridges running E. and W., the central one terminated on the west by a mass of rock seven acres in extent at the top, which is 443 ft. above the sea, and upon which stands Edinburgh castle. The palace of Holyrood is at the E. end of the same ridge. Along the top of the ridge runs the principal street of the old town for the distance of a mile, its successive parts being named Castle Hill, Lawn Market, the High street, Netherbow, and Canon-gate; it contains many public buildings, and is a fine street. Upon the sides of the ridge are the ancient houses, five, six, and sometimes ten and eleven stories high, laid out in flats, in which are concentrated a great part of the poor population. Steep lanes descend from the high ground on both sides, some not more than six feet wide, and others broad enough to admit the passage of a cart or carriage; the narrower ones are called closes, and the wider ones wynds. Along the valley into which these closes and wynds descend on the south runs Cowgate, which was once a fashionable street. At its W. extremity toward the castle is an open rectangular space called the Grass market. Near the E. end rises a belt of precipitous rocks called Salisbury crags, 547 ft. above the sea, behind which is a conical hill called Arthur's Seat, 822 ft. high. The S. portion of the city is connected with the old town by two bridges over the valley: South bridge, finished in 1788, and George the Fourth's bridge, finished in 1836. It is bounded S. by a large level park, called the Meadows. The ridge on which this part of the town stands is

more elevated than that occupied by the new town, but the latter is much more handsomely built. It is N. of the castle and the High street, and separated from them by a valley, crossed by the North bridge, which is opposite the South bridge, and was opened for use in 1768, and by a broad causeway, called the Earthen Mound, which has been a thoroughfare since the commencement of the century. This valley formed for centuries a lake called the North Loch, but it was drained in 1763, and has been laid out in gardens. The laying out of the new town beyond these gardens was begun in 1767. Its streets have a regularity and magnificence in strong contrast with those of the old town. The three principal ones are Queen, George, and Princes streets, parallel with each other and with the High street. George street runs along the middle of the ridge. Princes street is between it and the High street, and is one of the finest promenades in Europe; it is built up only on one side, and commands a fine view of the castle and the old town. Queen street is N. of George street, and fronts toward the north on the Queen street gardens. The new town is adorned by many fine open squares, among which are St. Andrew square, Charlotte square, Drummond place, Moray place, the Royal Circus, &c. East of the new town is a rocky eminence called Calton hill, the broad, verdant summit

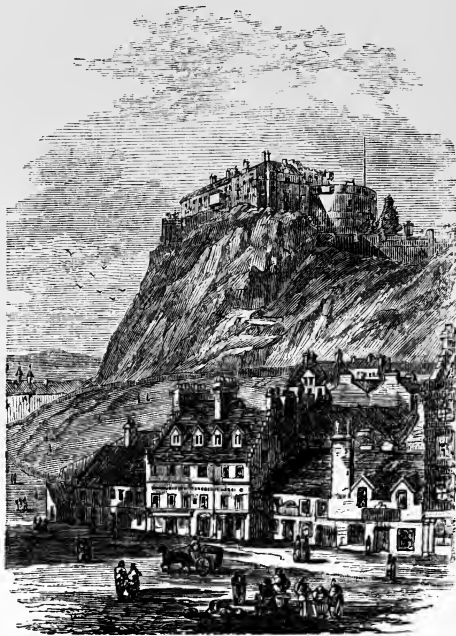

Edinburgh Castle.

of which is studded with monuments and looks out upon the frith of Forth. The new town is bounded on the north by a small stream called the Water of Leith, which empties into

the frith at Leith, the port of Edinburgh, distant 2 m. Leith is connected with Edinburgh by a spacious street called the Leith Walk.—Edinburgh castle is one of the most remarkable public buildings of the city. In former times it was called *Castrum Puellarum*, because, as it is said, the daughters of the Pictish kings resided there before their marriage. Its position upon a rugged basaltic rock, perpendicular on all sides except that next the old town, is picturesque and romantic. Its construction is irregular, and it has no great value as a fortification. It can accommodate 2,000 soldiers, and has an armory with space for 30,000 stand of arms. On its summit is a huge cannon, Mons Meg, formed of staves of wrought iron surrounded by hoops, supposed to have been constructed at Mons, Hainaut, in 1468. The regalia of Scotland, consisting of the crown, sceptre, sword of state, and treasurer's mace, are deposited in the crown room of the castle, and on the ground floor is a small apartment in which Queen Mary gave birth to James VI. The palace of Holyrood, in the E. part of the town, was the ancient residence of the Scottish kings. A part of the present structure was built in 1528, in the reign of James V. The edifice is quadrangular, with an open square in the centre, the sides of which are 94 ft. long. This palace was the residence of Mary, queen of Scots, and was the scene of Rizzio's murder. The queen's bedchamber is still shown almost exactly in the same state as when she occupied it. The largest apartment in the palace is known as the picture gallery; it contains 106 pictures which purport to be portraits of the ancient kings of Scotland. Adjoining the palace are the ruins of the abbey of Holyrood, founded by David I. in 1128. Its precincts, including Salisbury crags and Arthur's Seat, are a sanctuary within which debtors are privileged from arrest. The royal institution, one of the finest buildings of Edinburgh, built between 1823 and 1836, stands at the termination of the Earthen Mound and fronts on Princes street. It has a range of Doric pillars on each side and one in front. It belongs to the board of trustees for manufactures in Scotland, and furnishes rooms for the accommodation of the royal institution for the encouragement of fine arts in Scotland, and for other institutions. The national gallery of painting and sculpture stands upon the Mound; it is a fine building of the Ionic order of architecture. At the E. end of Princes street is the register house, a costly building 200 ft. long and 120 ft. broad, designed for the accommodation of the records of the Scottish supreme court, &c. Victoria hall, for the use of the general assembly of the church of Scotland, with its spire 241 ft. high, occupies a conspicuous position upon Castle hill.—Edinburgh is remarkable for the number of its monuments erected in honor of distinguished men. The Scott monument in Princes street is 200 ft. high. A marble statue

of Sir Walter by Steell is in its centre, and it has niches for representations of the principal characters in his writings. On Calton hill are monuments in honor of Dugald Stewart, Playfair, Nelson, and the Scotch soldiers who fell at Waterloo. On the S. side of the hill is the Burns monument, with a statue by Flaxman. Within the city are monuments also to Hume, Lord Melville, George IV., William Pitt (by Chantrey), the duke of Wellington, and others.—Edinburgh formerly consisted of a single parish, of which John Knox was for a time minister. The parish church was St. Giles's in the High street, named after the tutelary saint of the city. It is an ancient cathedral, 206 ft. long, containing three separate places of wor-

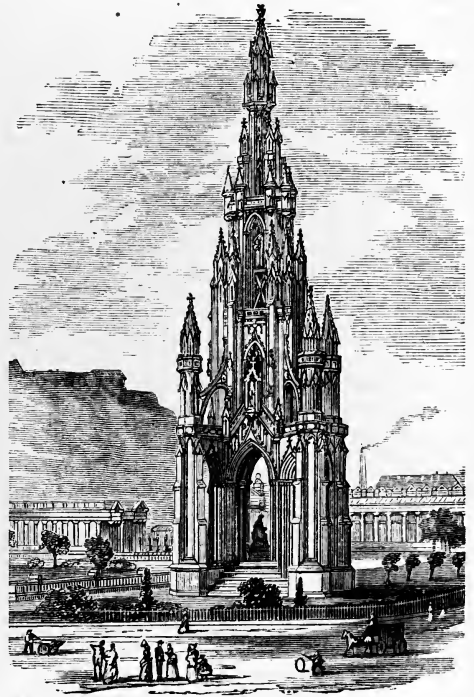

The Scott Monument.

ship, and adorned with a square tower which is surmounted by arches. They unite in the centre and support a spire which rises to the height of 161 ft. from the ground. The Tron church, so named from the tron or weighing beam which was formerly on or near its site, is in the High street at the intersection of the South bridge. The city has several other noted churches, of which three are Roman Catholic.—Among the charitable institutions, the most noted is George Heriot's hospital, founded by George Heriot, goldsmith and jeweller to James VI.; it is a fine old Elizabethan structure, designed by Inigo Jones. It is near the Grass market, on what is called High Riggs. It has a revenue of more than £17,000,

which is appropriated for the maintenance and education of children at the hospital, and for the establishment of free schools in different parts of the city. The hospital for the maintenance of poor children, erected out of funds amounting to £210,000 bequeathed by James Donaldson, printer, in 1830, is a handsome building. There are also within the city George Watson's, John Watson's, Gillespie's, and the orphan hospitals, the asylum for the blind, the deaf and dumb institution, and many other similar establishments. Edinburgh is also noted for its educational institutions. The principal of these is the university, which was chartered by James VI. in 1582. The front of the college building, 356 ft. long, is in South Bridge street. The building is of Roman architecture, heavy in design and massive in execution. There are faculties of theology, law, medicine, and the arts, with over 30 professorships. The many eminent instructors who have been employed in the medical school have given it a rank among the first in Europe. The university derives a revenue of £1,172 from foundations or bursaries, which is applied in aid of 80 poor students. The total number of matriculated students in 1872-'3 was 1,906, including 728 in medicine. Students are not required to live within the college walls, and are not subjected to discipline except when in attendance at the college. The university library contains 120,000 printed volumes and 500 volumes of MSS. The high school was founded in 1519; its present building, on the S. slope of Calton hill, was opened for use in 1829, and cost £34,000. It has a rector and four Greek and Latin masters, and the average number of students is between 400 and 500. The college founded under the auspices of the Free church is at the S. end of the Mound, and has about 500 students. There are many private medical schools of celebrity in the city which are not connected with the university. Students who attend them may obtain degrees in surgery upon examination from the royal college of surgeons. Among the other schools are the Edinburgh academy, the naval and military academy, the normal schools, Dr. Bell's schools, the Lancasterian schools, and the school of arts. The royal association has spent since its foundation £130,000 for promoting the fine arts, besides £81,000 for pictures and sculptures, and £3,000 for works to be deposited in the Scott gallery. The corner stone of the Watt institution and school of art was laid in October, 1872.—Edinburgh is the seat of the supreme courts of Scotland. The court which has supreme jurisdiction in law and equity is called the court of session, and is composed of 13 judges or lords. The court of supreme criminal jurisdiction is called the high court of justiciary. The right of pleading in the court of session belongs exclusively to an association of barristers called the faculty of advocates, and the privilege of preparing such papers and warrants as require the royal seal or signet is vested exclusively in

the writers of the signet. The judges and members of the supreme courts, including the advocates and writers of the signet, form what is called the college of justice, an institution founded by James V. in 1532. The old parliament house of Scotland is appropriated to the use of this body. It is in the heart of the old town, separated from the High street by Parliament square and the cathedral of St. Giles. Connected with it are the libraries of the writers of the signet and the faculty of advocates, both of which are extremely valuable, the latter being the finest in Scotland, and containing 150,000 volumes.—Several railways centre in Edinburgh. The Edinburgh and Glasgow, the North British, and the Granton have their termini in the valley N. of the old town, near the North bridge. The terminus of the Caledonian is in the W. part of the city, and of the Dalkeith line in the E. Through the Union canal, which connects with the Forth and Clyde canal, Edinburgh has communication with Glasgow.—On the establishment of the "Edinburgh Review" (1802) and the publication of the earlier works of Sir Walter Scott, Edinburgh began to be the seat of a large publishing business. There are about 60 printing houses, which give employment to more than 1,000 workmen. About 500 are employed in bookbinding. The manufactures of the city are not very important, but ale, shawls, carriages, and linen are made, and iron founding is carried on to some extent. The city is governed by a council of 41 members, which elects from its own number a lord provost, and six bailies, who constitute the civic magistracy. It has two representatives in parliament.—The city is supposed to have received the name of Edwin's burgh early in the 7th century, from Edwin, king of Northumbria, who is said to have made it his place of residence. The name of the place in Gaelic was Dunedin. It became a walled town and the capital of Scotland in the 15th century, when, after the murder of James I., its castle was selected as the only sufficient stronghold for the royal family and the government offices. The necessity of keeping within the walls was the cause of the houses being extended to such unusual heights. In 1513 the city was desolated by the plague. In 1544 the earl of Hertford, landing at Leith with an English army, set fire to the town, but failed to take the castle. Many conflicts took place here during the minority of James V.; one of the most violent, in which 200 men were killed, was between the Hamiltons and Douglasses, and is known in history as "clear the causeway." While John Knox was minister of Edinburgh, his preaching in 1556 gave occasion to tumults which were followed by the triumph of Protestantism. Disturbances also arose on the marriage of Queen Mary with Bothwell, and on the accession of James VI. of Scotland to the throne of England, when the union of the two kingdoms was proposed. In 1650 Cromwell, after the battle of Dunbar, took posses-

sion of the city and castle. From 1663 to 1685 large numbers of Covenanters were executed here on account of their faith. In 1736 John Porteous, captain of the city guards, ordered his men to fire upon a mob, and 6 men were killed and 11 wounded; he was tried, convicted, and condemned to death. He was relieved by Queen Caroline, then regent, and so much indignation was aroused thereby that he was forcibly taken out of prison by another mob and hanged. This prison, the Old Tolbooth, also called the Heart of Mid-Lothian, was taken down in 1817. Sir Walter Scott introduced the breaking open of the jail by the Porteous mob into the novel which he named after it.

**EDINBURGHSHIRE** (formerly MID-LOTHIAN), a maritime county of Scotland, extending about 36 m. from E. to W., and 18 m. from N. to S.; area, 367 sq. m.; pop. in 1871, 328,335. Its N. boundary is formed by the frith of Forth, and is studded with important towns and havens. The S. outline is very irregular, being deeply indented by Peeblesshire, from which it is partly separated by a continuation of the Moorfoot range. These hills, the highest of which is nearly 1,900 ft. above the sea, occupy an area of nearly 50 sq. m. in the S. E. part of Edinburghshire; but many fertile dales lie hidden among them, and a great part of their acclivities is under profitable cultivation. The Pentland hills, which extend from Peeblesshire N. E. through the centre of the county, are bleak and sterile, but afford some fine scenery. The soil, except in the valleys of the Forth and N. and S. Esk, is naturally inferior, and most of the land is used for pasturage, but the farms are skillfully worked. The chief crops are wheat, barley, oats, beans, peas, potatoes, and turnips. Good breeds of sheep and cattle are reared. The minerals comprise coal, limestone, sandstone, and porphyry. The chief streams are the N. and the S. Esk, Gala Water, and Water of Leith. The county is not extensively engaged in manufactures, but whiskey and the famous Edinburgh ale are largely produced. The Union canal and several lines of railway terminate at the capital. The principal towns are Edinburgh, Leith, Dalkeith, Musselburgh, and Portobello.

**EDISTO**, a river of South Carolina, formed by the union of the N. and the S. Edisto, the former rising in the W. part of Lexington county, and the latter in Edgefield. They unite a few miles W. of Branelville, whence the course of the main stream is S. E. and S. It enters the Atlantic by two channels, between which lies Edisto island, about 20 m. S. W. of Charleston. It is navigable 100 m. from the sea.

**EDMONDS, John Worth**, an American lawyer, born in Hudson, N. Y., March 13, 1799. He graduated at Union college in 1816, was admitted to the bar in 1819, and in 1820 commenced the practice of his profession in his native city. In 1831 he was a member of the lower branch

of the legislature of New York, and for the four years ensuing of the senate and the court of errors. Retiring from the legislature in 1836, he was sent on special missions by the federal government among the Indians. In 1837 he resumed practice in New York. In 1843 he became one of the inspectors of the state prisons, and with the sanction of the legislature substituted for corporal coercion the system of kindness. In 1845 he was appointed one of the circuit judges of the state of New York, in 1847 was elevated to the bench of the supreme court, and in 1852 became a member of the court of appeals. At the close of 1853 he retired from the bench, and has since been engaged in the practice of his profession in New York. Early in 1851 he began to investigate the subject of alleged intercourse with the spirits of the departed, and in the summer of 1853 made a public avowal of his belief in the same. In connection with George T. Dexter, M. D., he has published a work entitled "Spiritualism" (2 vols. 8vo, New York, 1853-'5; new ed., 1865). He has also published "Reports of Select Law Cases" (1868).

**EDMONDSON**, a central county of Kentucky, drained by Green river and Bear creek; area, 225 sq. m.; pop. in 1870, 4,459, of whom 226 were colored. The surface is hilly or moderately uneven; the soil is fertile and suitable for grass and grain. Coal is abundant, and a considerable portion of the county is occupied by beds of cavernous limestone. The famous Mammoth cave is situated here. The Louisville and Nashville railroad passes through the S. E. part. The chief productions in 1870 were 11,098 bushels of wheat, 172,998 of Indian corn, 23,684 of oats, and 414,940 lbs. of tobacco. There were 1,602 horses, 1,246 milch cows, 2,246 other cattle, 6,852 sheep, and 11,892 swine. Capital, Brownsville.

**EDMUND I.**, a king of the Anglo-Saxons, son of Edward the Elder, and successor of Athelstan, born about 922, ascended the throne Oct. 27, 941, and died May 26, 946. Immediately after his accession Aulaf, the Northumbrian prince, invaded Mercia, and was victorious at Tamworth and Leicester. Edmund concluded a peace with him, surrendering all England north of Watling street. Aulaf died the following year, and Edmund recovered Northumbria, and subsequently conquered Cumbria, and conferred it on Malcolm, king of Scotland, on condition that he should do homage for it, and protect the north from all future incursions of the Danes. As Edmund was celebrating a festival in Gloucestershire, he perceived Leof, a noted outlaw whom he had sentenced to banishment, enter the hall and seat himself at the royal table. Edmund turned to seize the ruffian, who stabbed him fatally in the breast. He was succeeded by his brother Edred.

**EDMUND II.**, surnamed Ironside, a king of the Anglo-Saxons, son and successor of Ethelred II., born in 989, ascended the throne in 1016, and died the same year. Even before his

accession he was recognized as the champion of the English cause against the Danes under Canute, but his abilities and hardy valor were unable to prevent the subjugation of the kingdom. Canute was proclaimed at Southampton at the same time that Edmund was recognized by the burgesses of London, which was immediately besieged by the Danes. Edmund fled, raised an army in Wessex, and at Scoerston in Gloucestershire gave battle to Canute, who was assisted by many disaffected English nobles and prelates under Edric. The battle raged for two days, and fortune seemed to have declared for Edmund, when a stratagem of Edric made the victory undecided. He again met his enemies at Brentford and at Otford; but by the perfidy of Edric, who had joined Edmund, and fled with his division at the onset, he sustained a decisive discomfiture at Assington. Edmund was prepared to meet Canute with a new army, when both the Danish and English troops, wearied of the strife, obliged their kings to compromise by dividing the kingdom. Mercia and Northumbria were the portion of Canute, and the southern parts were left to Edmund, with the provision that on the death of either the survivor should succeed to the entire kingdom. He is believed to have been murdered at Oxford, thus making way for the accession of Canute.

**EDMUNDS**, a S. E. central county of Dakota, recently formed, and not included in the census of 1870; area, about 900 sq. m. The E. portion is drained by branches of the Dakota or James river. The surface is mostly table land. The greater part of the county is occupied by the Plateau du Coteau du Missouri.

**EDOM**, or *Idumæa*, the ancient name of a region intervening between Palestine and Egypt. The book of Genesis describes it as the field or land of Edom. The word signifies red, and probably refers to the color of the mountain range. It was previously called Mount Seir, signifying rugged. Most of the tract is a rocky desert; but there is a considerable amount of soil that admits of cultivation, and vegetation enough for the maintenance of numbers of camels, goats, and sheep. The plain rises gently from the Dead sea to an imperceptible watershed, about 14 m. from the wady Ghurundel. Adjoining the Arabah are low calcareous hills, which are succeeded by a range of igneous rocks, chiefly porphyry, overlaid with red sandstone, reaching the height of 2,000 ft. Further E. is a range of limestone, 1,000 ft. higher, which sinks down into the plateau of the Arabian desert. The principal part of the country was that situated between the Dead sea and the gulf of Akabah; the limits and extent of the whole, however, are not precisely ascertained.—According to the Biblical narrative, Esau took possession of this land immediately after the death of Isaac; and when his descendants increased they extirpated the Horites, the original inhabitants. (See HORITES.) Eliphaz, Esau's oldest son, was the father of Am-

alek, whose descendants took possession of the desert et-Tih, which was afterward absorbed by the Edomites. The Edomites were at first divided into ten tribes, and some of these adopted subsequently an elective monarchy, while those of Mount Seir preserved their patriarchal organization. The list of the kings given in Genesis contains but eight names, and therefore does not carry us back more than two centuries before the exodus. The king of Edom refused the Hebrews permission to pass through his territory, and forced Moses to march round the edge of the desert, and turn the kingdom of Moab, to arrive at the Jordan. The power of the kings was subsequently extended over all divisions of the Edomites, and after the time of Gideon even over the remnant of the Midianites. After the settlement of the Hebrews the Edomites were constantly at war with them. Saul fought against them successfully, and David defeated them completely, and placed garrisons in their towns. Hadad, an Edomite prince, excited a rebellion against Solomon, which was suppressed. The Edomites remained thereafter a dependency of Judah, and revolting with the Moabites under Jehoshaphat, they sustained great losses without gaining their object. They were more successful in the time of Joram, and were once more ruled by their own kings. Amaziah defeated them in the Salt valley and took the city of Sela (afterward called Petra by the Greeks), the capital of the new Edomite monarchy. The Edomites regained their independence during the reign of Ahaz by the help of Rezin, king of Syria, and Pekah, king of Israel, and laid waste the southern portion of Judah. The first king of the new monarchy is supposed to be the Kadumalka mentioned by the Assyrian king Tiglath-pileser II. as one of his tributaries. The Edomites continued dependent upon Assyria until the time of Nabopolassar, when Necho, king of Egypt, overran the whole of Syria, and took his share of the spoils of the Assyrian empire. After the defeat of the Egyptians by Nebuchadnezzar the Edomites were incorporated in the Chaldean empire. About this time the name Edomite begins gradually to disappear, and in its stead is found the hitherto unknown word Nabathean. This is ascribed by some to an internal revolution, a change of the royal race and of the dominant tribe, of which we have no record. The monuments of Asshur-bani-pal (about 660) are the first that speak of the "country of the Nabatheans." In 590 these Nabatheans, or Edomites, joined with the Moabites, Ammonites; and Tyrians in the revolt of Zedekiah, king of Judah, against Nebuchadnezzar, which proved fatal, and drew upon them a complete devastation of their country and their capital Sela or Petra. They soon recovered from its effects, and their trade regained even a greater activity, for the complete ruin of Tyre rendered Petra the chief station for caravans from southern Arabia and the great market of the produce

of India. Their prosperity increased under the Persian kings, whose supremacy they peaceably acknowledged, and long survived the fall of Persia. After the time of Alexander the Great the Nabatheans formed an independent kingdom, which was often at war with the Jews. The prince of the latter, John Hircanus, annexed most of Idumæa. The Romans absorbed it under Trajan. Herod, who reigned in the time of the emperor Augustus, and the emperor Philip, surnamed the Arab, were Idumæans. The country was overrun by the Arabs in the 7th century, and ceased to form a distinct political division.—Besides Petra, the principal inland town was Bozrah, their ancient capital; and on the sea were the ports of Elath and Eziongeber, both of which were captured by David, and Havara, afterward called Leucecome by the Greeks. The government was a kind of tribal system, each tribe having its chief, subject to the supreme authority of the king. In the inscriptions recently found, persons are designated as scholars, doctors, and poets, revealing that they possessed some intellectual and literary culture. The monuments show that the supreme deity was Al or El, with a feminine counterpart under the name of Alath; other gods were principally the various Baalim, Baal Samim, Yarhi Baal, &c. Religious pilgrimages were very frequent, and the most important were to Wady Feiran, to Mount Serbal, and especially to Tor on the shores of the Red sea.—The history and topography of ancient Edom have recently been made subjects of careful investigation, and much important information may be found in Palmer's "Desert of the Exodus" (2 vols., London, 1872), Tristram's "Land of Moab" (London, 1872), and in "The Ordnance Survey of Sinai, with Notes, Plans, &c." (London, 1872).

**EDRED**, a king of the Anglo-Saxons, son of Edward the Elder, successor of his brother Edmund I, ascended the throne in 946, and died Nov. 23, 955. The two sons of Edmund being children, Edred in an assembly of the prelates and thanes was chosen king, and consecrated, in the style of his charters, to the "government of the Anglo-Saxons, Northumbrians, pagans, and Britons." Though afflicted with a lingering disease, he marched into Northumbria and quelled the turbulent Danes. In this reign St. Dunstan rose to power, and important ecclesiastical and monastic reforms were undertaken. His nephew Edwy succeeded him.

**EDRISI**, an Arabian geographer, supposed to be the person mentioned by historians of his nation under the name of Abu Abdallah Mohammed ben Mohammed ben Abdallah ben Edris esh-Sherif, who was a descendant of the Mussulman Edriside princes who reigned at Fez before the Fatimites, born in Ceuta in 1099, died in Sicily about 1180. He studied at Cordova, where he distinguished himself by his knowledge of cosmography, geography, philosophy, medicine, and astrology, and by his skill as a poet. After visiting Constanti-

nople, Asia Minor, Egypt, Morocco, Andalusia, France, and England, he went to Sicily on the invitation of King Roger II. He made for that prince a terrestrial globe of silver, upon which he inscribed in Arabic characters all that he knew of the various countries of the earth. To explain the globe, he compiled from the reports of travellers a treatise on geography. The globe is lost, but a complete manuscript of the geography was discovered in the royal library at Paris in 1829, of which a French translation by Jaubert appeared in 1836-40. Several portions and abridgments of the work had been published many years before. Edrisi divides the earth into seven climates or zones, and each of these into eleven regions; and in his descriptions he adheres strictly to his scheme, without considering whether his divisions resemble those which have been traced by natural features or society. His work represents the state of geographical knowledge among the Arabs in the 12th century, and although it contains nearly as many errors as there are in Strabo, it was the source from which the western geographers derived their notions prior to the Portuguese discoveries in the 15th century.

**EDUCATION** (Lat. *educare*, to bring up, to instruct), the development and cultivation of the various physical, intellectual, and moral faculties. In a general sense, it comprehends all the means which contribute to this result in an individual from infancy through manhood—the agencies by which the faculties of the mind are drawn out, its powers disciplined, and knowledge acquired; embracing the arrangements and contrivances for the better nursing, training, and rearing of children, their physical and mental development, their nourishment, cradles, nurseries, gardens, games, and amusements; schools of every grade, from the kindergarten to the university, including special, technical, and professional schools, together with school architecture and all apparatus, means, and methods of instruction, and institutions for the instruction of every class of society, the blind, deaf and dumb, insane, idiotic, vicious, criminal, &c.; besides the instruction afforded through literature, the pulpit, and educational societies. "Education," says Paley, "in the most extensive sense of the word, may comprehend every preparation that is made in our youth for the sequel of our lives." Without treating the subject in its broadest sense, or in its strictly metaphysical relations, and without dwelling upon the various theories and speculations that have been advanced concerning education by philosophers and educators, the aim of this article will be to treat generally of the system and condition of education in the principal countries of the world, as represented by their public schools and other institutions for instruction. Details and statistics will be found in the articles devoted to the separate countries, states, and institutions of learning, as



well as separate articles on the various subjects comprised under the general head of education, such as BLIND, COLLEGE, COMMON SCHOOLS, DEAF AND DUMB, GYMNASIUM, IDIOCY, INSANITY, INFANT SCHOOLS, MILITARY SCHOOLS, NORMAL SCHOOLS, and UNIVERSITY.—In the earliest ages the entire education and culture of the people were in the hands of priests, who were the first founders of institutions, the first savants, statesmen, judges, physicians, astronomers, and architects; and science has been separated from religion, and teaching has been a distinct profession, only in the most highly civilized communities. Even in these, learning and schools have often been to a greater or less extent, more or less directly, under the patronage and care of religious bodies, since religion has been esteemed by all nations the highest interest of society. Historians usually account the inhabitants of India the most highly educated of the ancient nations of the East. Yet Hindoo learning and science have always been almost exclusively in the hands of the caste of Brahmans, who are allowed to explain the Vedas or sacred books only to the two castes next in rank. The early culture of the Egyptians was such, that the Greeks derived from them their first lessons in science and philosophy. In Egypt, too, the Israelites obtained the knowledge which enabled them to measure and “divide the land.” Public education existed only in the castes of priests and warriors, until it became more general after the rise of the Persian and Greek dominion. While the mass of the people were trained to the mechanical arts, a few only were instructed in the mathematical sciences, and in the doctrines of morality and religion.—The theocratic constitution of the Hebrew nation, and the founding of its politics and ethics on religion, produced a mental cultivation as manifested in its literature very unlike that found among any other oriental people. The schools of the prophets are the only schools which are mentioned, but children were generally instructed by their parents in the law of Moses and the history of the nation. The obedience of children to the commands of their parents is a frequent injunction in the Scriptures. Girls were taught to sing, to play upon musical instruments, and to dance on solemn occasions; and many female poets and learned women figure in the history of the ancient Jews. After the exile the rabbis established schools to which children were sent from their 5th or 6th year, and in which, besides the teaching of the Scriptures, the commentaries and traditions, the Mishnah and Gemara, were taught and committed to memory. The instruction was oral, no student ever taking notes, and the Mishnah had long been transmitted from master to pupil before it was committed to writing. The most celebrated of the early rabbinical schools were those of Jamnia (long under the direction of Gamaliel, and at which Saint Paul studied), Tiberias,

Alexandria, Babylon, and Jerusalem. During the greater part of the middle ages Jewish astronomers, physicians, poets, and philosophers were scattered through the cities of northern Africa and western Asia, Spain, Italy, and France. Their greatest schools flourished in Babylonia, Egypt, Fez, Andalusia, and Languedoc.—The culture of the ancient Persians was the exclusive care of the magi, a priestly caste of Median origin, who were the savants of the empire, the legislators, judges, interpreters of dreams, astrologers, and highest functionaries at court. There was no general system of national education, but the instruction was simple for the people, learned and religious for the magi, and military and political for the warrior. According to Herodotus, “they instructed their boys from their 5th to their 20th year in three things alone, to ride, to draw the bow, and to speak the truth.”—In Greece, boys at the age of six years passed from the exclusive care of their mothers, who educated them till then along with the girls. At about their 8th year the boys were intrusted to the care of a pedagogue, who accompanied them to school, and kept them constantly under surveillance. The schools were under the supervision but not the patronage of the state, and the fees received from pupils constituted the schoolmaster’s income. Instruction began in the early morning, and was in three branches: the letters (comprehending reading, writing, and arithmetic), music (including also literature and art), and gymnastic exercises. Having learned to read, the boy was made familiar with the works of the poets, and required to commit to memory long select passages. Attendance at school was continued till the 16th or 18th year, after which those who wished became disciples of teachers of a higher order, the philosophers, rhetoricians, and sophists. For girls there were neither educational institutions nor private teachers. It was in obedience to the principles of the code of Solon that Athens became the centre and mother of liberal culture. Though education, like religion, was recognized as a part of the political constitution, yet the state left it to parental interests and affection to educate the young, ordaining only certain general rules, chiefly in behalf of morality. Thus every citizen, under a severe penalty, was required to teach his son to read and to swim; he was also to fit him for some occupation, otherwise the son would not be obliged to support him in his old age. Intellectual and æsthetic culture was always prominent in Athenian education, and gymnastic training was encouraged as much in the interest of physical beauty as of physical strength.—The Hellenic methods of education were in most respects copied by the Romans, who, however, at first laid greater stress on vigorous corporeal exercises and the encouragement of patriotism. The ancient title of the schoolmaster was master of the games (*ludi*

*magister*), and instruction was entirely independent of the state till near the time of the emperors. Under the empire the Greek literature was taught to the sons of the wealthy as carefully as the Latin, and the education was completed by rhetoricians, who in the time of Quintilian often received a salary from the public treasury. Athens, where there was an academy with 10 professors, was much frequented by the young Romans, and a school of high repute was founded in Constantinople by Constantine and reorganized by Theodosius the Younger. Girls were often carefully educated during the latter period of the empire; and from about the close of the republic there appear to have been schools designed for them exclusively, where they were rarely visited by their fathers.—The early Christians, unable to find separate schools for the education of their children, either instructed them at home or sent them to pagan schools. The most flourishing of these schools in the 2d century was that of Alexandria, where a multitude of pagans, Jews, and Christians prosecuted their studies together. By the side of this ancient institution soon arose the Christian school of the catechists, said to have been founded by Pantaenus in 181, in which Christian theology assumed a regular and scientific form. Similar schools were soon established at Cæsarea, Antioch, Edessa, &c. In the West there were till the 5th century pagan schools in the largest cities, as Carthage, Rome, Milan, Treves, Marseilles, and Lyons; and owing to the paucity of the Christian institutions, it was common for distinguished doctors of the church to assemble around them the young men who purposed entering the priesthood, and to instruct them by their conversation rather than by regular lessons. Early in the 5th century learning found a refuge in the monasteries, which had been introduced in the East for purposes of solitude and contemplation, but in the West for quiet and union amid the disorders of society. In the 6th and 7th centuries the schools were of three classes, the parochial, the cathedral or episcopal, and the cloistral or conventual. The Irish monasteries at this time surpassed all others in maintaining the traditions of learning. The course of seven sciences or liberal arts, divided into the trivium (grammar, dialectics, and rhetoric) and the quadrivium (arithmetic, geometry, astronomy, and music), was introduced in the 6th century, and defined in two jargon hexameters:

*Gramm. loquitur; Dia. vera docet; Rhet. verba colorat;  
Mus. canit; Ar. numerat; Geo. ponderat; Ast. colit astru.*

The 7th century, says Hallam, was the nadir of the human mind in Europe, and its movement in advance began with Charlemagne before the close of the next. This monarch invited to his court Alcuin from the cloisters of York, Clement from Ireland, and Theodulf from Germany, and reestablished the palatial

school, in which the sons of some of the nobility were educated with his own children, and which accompanied him wherever he went. In this school (called the palatine academy), and afterward in those of Tours and Fulda, the course of instruction embraced all the learning of the age. He also founded schools in every bishopric and monastery, in which reading, singing, computation, grammar, and the learning of psalms by heart were the exercises. Less than a century after Charlemagne, King Alfred revived letters and schools in England, which had been almost extinguished by the Danish invasion, rich libraries having disappeared in the pillage of churches and convents. At his accession Wessex could not boast a single person able to translate a Latin book. He invited to his court the most celebrated scholars, established schools in different parts of his kingdom, and ordained that the children of every free man whose circumstances would allow it should acquire the arts of reading and writing, and that those designed for civil or ecclesiastical offices should be instructed in the Latin language. Yet his efforts in behalf of learning were as unfruitful after his death as those of Charlemagne had been in France, and were succeeded by the mental torpor of the 10th century, in which, it has been remarked, no heresies appeared. As learning in that age was chiefly contained in a dead language in all the countries of Europe, it did not reach the mass of the people; the art of writing was so rare among laymen even of the higher ranks, that it was called the clerical art. In the 10th century, the darkest period of Christian literature, the Arabs had flourishing schools of learning from Bagdad to Cordova. Of their 17 universities, that of Cordova enjoyed the highest reputation, and is said to have possessed a library of 600,000 volumes. Grammar, the art of versifying, history, geography, astronomy and astrology, chemistry and alchemy, mathematics, and medicine were all studied; and in the last two departments the Arabians made important improvements on their Greek masters. An elementary school was attached to every mosque, in which reading and writing were taught, the pupils at the same time learning many poems by heart. The universities were chiefly occupied with theology, jurisprudence, and speculative philosophy; and for the natural sciences there were special schools, while medicine was taught in hospitals. The rise of the scholastic philosophy and of the troubadour poetry, the institution of universities, and the return to a profound study of the Greek and Latin classics, were the literary steps during and after the 11th century which preceded the revival of learning in the 14th and 15th centuries.—From the 12th and 13th centuries, the era of the schoolmen, date 20 universities, including those of Paris, Montpellier, Oxford, Cambridge, Bologna, Padua, Rome, Salamanca, and Lisbon. That of Bologna was especially famous for its revival

of the civil law, and attracted lawyers and students in large numbers to northern Italy from remote parts of Europe. Paris was unrivalled in the department of theology, and Montpellier in that of medicine. During the period preceding the revival of learning female education declined. Only a few schools were maintained in the large cities for the instruction of girls in reading, and the inmates of convents were taught hardly more than to repeat their prayers and to practise embroidery and other needlework. When the Byzantine empire approached its fall, the Greek scholars who had there preserved some acquaintance with ancient learning took refuge in Italy, where the love of letters had been already awakened by the genius of Dante, Petrarch, and Boccaccio, and where industrious scholars under the patronage of princes were devoting their lives to the recovery of manuscripts and the revival of philology. From Italy the more profound study of classical authors passed to the other countries of Europe, and a contest was long maintained between the scholastic and the anti-scholastic studies; between the Aristotelians, who included the most learned ecclesiastics, and the Platonists, to whom were attached most of the cultivators of polite literature. Agricola in Germany, Valla in Italy, and above all Ramus in France, wrote against scholasticism. It was assailed by the reformers and defended by the Jesuits, and is still in honor in some of the Spanish universities. Purbach, Regiomontanus, and Nicholas Casanus were the first to promote the study of the higher mathematics. Nicholas de Clemangis and Gregorius Tifernas revived the classical taste in France, Vitelli and Coilet in England, Lebrixa in Spain, and Reuchlin in Germany. The pious "Brethren of the Common Life," whose first school was founded by Gerard Groot at Deventer in 1376, also exerted a wide influence. Their schools were extended throughout the Netherlands and Germany, were distinguished alike for piety and solid acquirements, and attracted students even from Italy. In Brabant the university of Louvain was the centre of a wide intellectual culture, and the *alma mater* of many celebrities. Its European reputation increased till in 1570 it had 8,000 students. The golden age of the literature of the Spanish Netherlands was that of Albert and Isabella in the first quarter of the 17th century, in which the triumph of the renaissance was completed.—Education and the doctrines concerning it played an important part in the movements of the Protestant reformers, and also in the reaction in favor of the papacy under the Jesuits. The revival of intellectual culture among the people was associated in the mind of Luther with religious reform, and in 1528 with the aid of Melancthon he drew up the plan of studies which was followed in the Protestant common schools of Germany till the close of the century. The first class learned to read, to repeat from memory a few distichs, to write, and to

sing, and began the study of Latin. The second class studied Latin, grammar, and music for an hour daily, read and interpreted the fables of Æsop, the *Padologia* of Mosellanus, and the colloquies of Erasmus, and committed to memory parts of Terence and Plautus, and some of the psalms and other portions of Scripture. The third class advanced to the Latin poets, and to exercises in dialectics and rhetoric, and were required to speak in Latin, and to write an exercise in that language weekly. Luther also assailed the Aristotelianism and scholastic methods which prevailed in the universities, and recommended the establishment of libraries in every town. Education was in like manner encouraged by Zwingli and Calvin, the latter of whom caused the erection of a splendid edifice for the gymnasium of Geneva, to which eight distinguished professors of Hebrew, Greek, philosophy, and theology were invited. About this time the gymnasium of Strasburg under Johann Sturm became the most flourishing of the age, and in 1578 it had more than 1,000 students, 300 of whom were of noble or princely birth. The Protestants having awakened a zeal for learning, the Jesuits determined to avail themselves of this zeal in the interest of the Catholic church, and to combat the reformation with its own weapon. They cultivated to the highest possible degree all departments of science, and employed the authority of learning in favor of the pontifical power. From Cologne, Ingolstadt, and Vienna they spread between 1550 and 1560 throughout Germany. Opposed in France by the Sorbonne, the university, and the parliaments, they did not establish their first school in Paris till 1665; but in 1750 they had won from the ancient Benedictines their pedagogic laurels, and possessed in France 669 schools, which were attended by the children of the princes and nobles.—Between the latter part of the 17th and the close of the 18th century, four distinct theories and methods of the pedagogic art arose, which are usually named the pietistic school, the humanistic school, the philanthropic school, and the eclectic school. Jansenius in the Netherlands, the Wesleys in England, and especially Spener and Francke in Germany, were the first representatives of the pietistic tendency. Spener was the teacher of Francke, who established a school at Halle for children of both sexes, and another for teachers, on the principle that religious and moral instruction should be made more prominent than intellectual acquirements, that the end of education should be a living knowledge of God and of pure Christianity. It was succeeded by similar schools in many other cities. In Greek the New Testament was the only text book. Hebrew was one of the studies of the regular course, and a change of heart was declared essential to successful scholarship. The humanistic school maintained the principle that the ancient languages and literature, especially the Greek and Latin (which were termed the

humanities), should be the foundation of education, and should be exclusively studied till the pupil went to the university. Basedow, Campe, and Salzmann were the foremost representatives of the school which made philanthropy the aim of all education, and conformity to nature its basis. Under the name of ecclesiastics are classed those who were the disciples of no exclusive school, but from truly philanthropic motives sought to instruct classes hitherto neglected. Such was the origin of the efforts for the instruction of deaf mutes by Heinicke, Braidwood, the abbé de l'Épée, and Sicard; the instruction of the blind by Valentin Haüy, Klein, and Lenne; the institution of Sunday schools by Robert Raikes, Oberlin, and others; the organization of reformatories by Odescalchi and Tata Giovanni in Rome, and by the philanthropic society in London; and many of the special schools of commerce, agriculture, mines, the arts of design, and other departments.—In Germany since the latter part of the last century the principles of education have been actively discussed, the most prominent writers on the subject, besides some who have been already mentioned, being Sulzer, Miller, Weisse, Ehlers, Büsch, Feder, Resewitz, Gurlitt, Funk, Heusinger, Niemyer, Schwartz, and Beneke. But the man who for the last hundred years has exerted the greatest influence on education is the Swiss Pestalozzi. According to the principles developed by him in various writings, education must begin early, under the discipline of home and the direction of parental wisdom and power. It must proceed according to the laws of nature, slowly and uninterruptedly, the teacher exciting the child to activity and rendering him but a limited amount of assistance. Individuality must be held sacred, and carefully studied and encouraged. Verbal teaching is futile unless it be implanted on previous mental experiences and verified by the senses. A development by merely mental operations, which the Socratic method favors, is vain and harmful, for the child can only utter a judgment concerning an object when he has examined it experimentally, and learned precisely to distinguish its qualities and attributes by words. Form, number, and language are the elements of knowledge, the principles by which the mind must be developed; and a thorough acquaintance with them in the various departments of learning constitutes an education. Therefore mental arithmetic, geometry, and the arts of drawing and modelling objects of beauty, are as important exercises as the study of languages. The school should be a place of liveliness and activity, and the scholar should have opportunity to exercise and reveal his power. The system of Pestalozzi has been adopted in the Prussian schools with slight modifications, and has exerted a greater influence than any other on teachers in England, America, and the north of Europe. His system was modified by Fellenberg in his institution

at Hofwyl, by Jacotot in the university of Louvain, and by Felbiger, bishop of Sagan, in the schools which he organized. There were combined at Hofwyl an agricultural institute, theoretical and practical, a rural school for the poor, a superior school for the sons of the nobility, an intermediate school for those of the middle classes, and a normal school for the instruction of the teachers of the canton. To Fröbel, the founder of the kindergarten, also belongs high honor for his reform in the principles of education.—While secondary schools have a long history, public elementary schools for the poor are of modern origin. Although government regulations concerning schools had long existed in Prussia, the present system of that country may be said to date from 1794, when the general common law (*allgemeines Landrecht*), which was prepared by order of Frederick the Great and promulgated under his successor, declared all public schools and institutions of learning to be under the supervision of the state, and established regulations for their support, management, inspection, appointment of teachers, obligatory attendance of pupils, &c. By the same order it was declared that teachers in "the gymnasia and other higher schools have the character of state functionaries." The constitution of 1850 declared that "all public and private establishments are under the supervision of authorities named by the state." National education in France may be said to date from 1833. Prior to that time many institutions for secondary, superior, and the highest culture had been liberally supported, but the educational wants of the masses had been greatly neglected. In 1831, when Guizot was minister of public instruction, Victor Cousin was sent to Prussia to study and report upon the educational system of that country. As a result of this mission a new school law for France was passed in 1833, many features of which still remain. In England until recently the establishment and maintenance of schools have been left entirely to the people. In 1834 the government began to make grants in aid of schools, and in 1839 a committee of the privy council on education was constituted for the distribution of the money. The most important step toward governmental control of education was made in 1870, when grants were authorized for the maintenance of elementary schools and their partial supervision by the government. For a more detailed statement of the historical development of national education, see COMMON SCHOOLS.—In all civilized countries education has come to be regarded by the government as a leading force not only in producing the best results in public intelligence, virtue, and citizenship, but also in developing the physical strength, as seen in war, and the material prosperity of the nation, attended with a corresponding increase of the national wealth. This is attested by the advantage gained in agriculture, commerce, industry, and skilled

labor in general, by those nations in which schools of agriculture, commerce, the arts and trades, and other special schools have received their highest development. The superiority of the Prussian arms has been attributed not only to the military organization and discipline of that country, but also in a large measure to its magnificent system of civil education. On maps showing the distribution of wealth and illiteracy in the United States, the maximum of the former is generally found in those sections where the minimum of the latter exists. And so the wisest statesmen and publicists have found that the best way to diminish the crime and pauperism of a community is to lessen its ignorance. Dr. Wines reported in 1869 that 95 per cent. of the convicts in France were illiterate, 34 per cent. in the English county or borough prisons, 49 per cent. in Belgium, 83 per cent. in Switzerland, 40 per cent. in Italy, and 35 to 38 per cent. in the Netherlands; while in the United States the percentage is about 22 of the totally ignorant and about 50 of the very deficient. Mr. E. D. Mansfield, in discussing the relation between crime and education (in the report of the United States bureau of education for 1872), concludes: "First, that one third of all criminals are totally uneducated, and that four fifths are practically uneducated; secondly, that the proportion of criminals from the illiterate classes is at least tenfold as great as the proportion from those having some education." According to the same authority, about 60 per cent. of paupers in the United States are totally ignorant, and about 13 per cent. of illiterates are paupers. "In other words, the proportion of paupers among the illiterates is 16 times as great as among those of common education." Dr. Jarvis of Massachusetts has shown that an important relation exists between education and health. Dividing the marriages for a given period in England into classes, in the first of which from 20 to 30 per cent. of the women were illiterate and in the second from 60 to 70 per cent., he found that 14.65 per cent. of the children born in the first class died under one year old, and 24.87 per cent. of those in the second. These and other considerations have recently led to a fuller recognition of the right and duty of the state to provide for public education. Hence in France, Russia, Italy, Great Britain, the United States and other countries, radical reforms in the system of education have been introduced or agitated, and the plan of compulsory education for all children of school age has been widely extended and is still undergoing a rapid growth. In Prussia, as early as 1763, a decree of Frederick the Great required parents to send their children to school, a duty which is still enforced by admonitions, reprimands, and fines. Obligatory attendance is a prominent feature of the educational system of Austria, Italy, Switzerland (except in the four small cantons of Geneva, Schwytz, Uri, and

Unterwalden), Denmark, Norway, Sweden, and other European states. The new school law of England simply permits the school boards to enforce attendance of children between the ages of 5 and 13 years; while in France compulsory education is among the reforms agitated. In the United States provision is made for compulsory school attendance in the constitutions of several states. In some states laws to this effect are now in force, while in numerous others the highest officers of public instruction have urged the necessity of such laws. Educators have usually classified general education into three grades, primary, secondary, and superior; and the schools of all countries have been arranged correspondingly. The lines of separation, however, are not drawn with precision, and the classification varies in different countries. Thus in Europe the primary division embraces the lower grades of schools; the secondary, the colleges, gymnasia, and *Realschulen*; and the superior the universities. In the United States, the primary division embraces the lowest grade of schools; the secondary, the academies and high schools; and the superior, the higher institutions of learning, such as colleges. Some authorities regard colleges as within the second class, and assume that there is no provision for superior education in this country. Outside of these grades is the special education afforded in all countries by the professional and technical schools. Perhaps a more satisfactory classification would be: 1, elementary schools, including common schools, evening schools, and schools for the blind, deaf and dumb, and idiots; 2, middle schools, comprising colleges, gymnasia, *realschulen*, &c.; 3, professional and technical schools; 4, universities.—The plan of public instruction in Prussia, which also prevails generally throughout the German states, has long been preëminent as the most complete system of national education yet developed. The cardinal features of this system are: 1, the right and duty of the state to establish a sufficient number of elementary schools for all children of school age; 2, the obligatory attendance of every child between the ages of 7 and 14 years at some elementary school, public or private; 3, the special preparation of teachers, as far as practicable, for every grade of school, with opportunities for professional improvement and promotion, and guaranty of pecuniary aid when sick, infirm, or aged, and for their families in case of death; 4, a system of inspection, intelligent, frequent, constant, and responsible, reaching every school and every teacher. The superintendence over all institutions of instruction, private and public, belongs to the state. Formerly the supervision of the schools in the lower grade was held largely by the clergy, but in 1872 a new school law was passed looking to the entire separation of school and church, and withdrawing the direction of educational matters from the clergy as such, al-

though clergymen may be and are appointed by the state as school superintendents. For political purposes the state is divided into 11 provinces, which are subdivided into 35 regencies (*Regierungsbezirken*), and these again into districts (*Kreise*) and parishes (*Gemeinden*). These divisions are also adopted for educational purposes. The supreme authority in all matters relating to education is vested in a minister of public instruction, who is appointed by the crown. Local supervision is vested in the provincial authorities, who have general control of secondary education, including the gymnasia, realschulen, and primary normal schools. Each province has a *Consistorium*, which is divided into two sections, one for ecclesiastical purposes, and the other, the *Schulcollegium*, for educational affairs. The members of the latter receive their appointment and salary from the crown. As a general rule, the administration of the school fund provided by the state, and the management of the lower and elementary schools, are exercised by the civil government of the province, while the *Schulecollegium* supervises the higher schools, the general system of instruction and discipline, the selection of text books, the examination and appointment of masters, and the examination of those who leave school for the universities. Immediately below this is the church and school section of the supreme council of the regency, presided over by the school councillor (*Schulrath*), and charged with the examination and appointment of teachers in the primary schools, with keeping the schools in good condition, and with collecting and disbursing school funds. The educational affairs of a district are intrusted to the councillor of the district (*Landrath*) and the inspector. Finally, each commune or parish must have its school, and each school its committee of supervision (*Schulvorstand*), consisting of the curate, two magistrates, from two to four notable persons of the parish, and its inspector, usually the parish clergyman. In the larger towns and cities the general management of all the schools is intrusted to a board consisting of the burgomaster (mayor), members of the municipal council, pastors, and directors of the higher schools. There is also a committee of management for each school. A complete plan of inspection exists throughout the system. Each of the heads of council, from the highest to the lowest civil division, is appointed by the government, and has the power of veto over the acts of the council, board, or committee over which he presides. Thus the entire school system is completely under the control of the general government. In case the funds arising from endowment, tuition, &c., are insufficient, the deficit is made up by local taxation. The rate of tuition is low, generally one groschen (2½ cents) a week in the villages, and from 10 silver groschen to 2½ thalers a month in the towns. Children unable to pay this amount may have the benefit of a deduction,

or be admitted entirely free. Each parish or commune must maintain its own school; if it is unable to do so, the district, the province, and the state share the expense. Attendance upon the schools is obligatory during school age, 7 to 14, and is enforced by admonitions, reprimands, and fines. A close supervision over the examination and appointment of teachers is maintained by the government, and no teacher is appointed until his moral and educational qualifications have been proved. Private schools may be opened by individuals, but they must be under state supervision, and the teachers must be examined and receive permission to teach from the government authorities. The schools of Prussia may be divided into five general classes: 1, primary; 2, burgher; 3, *Realschule*; 4, gymnasium; 5, university. Besides these there are normal schools or teachers' seminaries of three grades, and a great variety of special and professional schools devoted to instruction in the practical arts, and the application of science to industry, the liberal professions, and the fine arts. In country or smaller towns the *Volksschulen* combine the American primary and grammar schools; children enter at six years of age, and remain till their school education is completed. In the burgher schools the course of instruction covers eight years, and embraces the ordinary elementary studies, prominence being given to religious instruction, music, drawing, and gymnastics. During the first three years the sexes are taught together; afterward in separate schools, except in villages where the population is small. Generally no opportunities are offered in the public schools for the higher education of girls, except that afforded by the burgher schools; but in several of the cities schools have been organized for this purpose. Instruction in household work, handiwork, or some branch of trade, is given in the regular course, or in separate departments. The burgher schools are of several grades, the highest ranking with the American high school. The realschule has a "realistic" course (*Realia*), which differs from that of the gymnasium mainly in being less classical, and which provides a broad course of education for those intending to pursue commercial or mechanical occupations, or prepare for any of the special schools without entering the university, their object being to "prepare by scientific education for those higher vocations of life for which academic studies are not required." Realschulen are classified into those of the first rank, those of the second rank, and higher burgher schools. The ordinary studies of the realschule are German, French, English, Latin, mathematics, geography and history, natural history, physics and chemistry, mechanics, drawing, religion, singing, and turning or gymnastics. Students are usually admitted at seven years of age, and complete their studies at 15 or 16. From 32 to 34 recitations, of 50 minutes each, are required each

week. The highest secondary institution is the gymnasium, which is intended to prepare students for the university. The general plan of instruction is fixed by the state, and great prominence is given to classical studies. The course covers nine years, students being usually received at 9 or 10 and graduated at 18 or 19. The number of recitations varies each year, and ranges from 25 to 32 a week, exclusive of singing and turning. The realgymnasium has a classical and a realistic course combined. On the completion of the course in the gymnasium, a thorough examination (*Abiturienten-Examen*) is held, which the student must pass satisfactorily before obtaining the certificate (*Maturitätszeugniß*) by which alone admission to the university is secured. A marked feature of the Prussian system is the governmental supervision of university education. The universities, of which Prussia has ten, were in most cases founded by the sovereign, who endowed them with lands and money. The government retains supreme authority over these institutions, and even appoints the professors; it also provides for deficiencies in their incomes. Special officials (*Curatores*) form the connecting link between the government and the universities. The German university comprises four schools called faculties: theology, law, medicine, and philosophy. The last named comprises language and literature, the mathematical, physical, and natural sciences; in short, the whole range of knowledge as considered independent of the professions. The course of study is commonly four years. Most thorough instruction is given by means of lectures, and examinations are held for degrees. The extent of the instruction provided may be inferred from the fact that nearly 400 distinct courses of lectures, covering the entire realm of science, letters, philosophy, and religion, are given during the year at the Frederick William university in Berlin. To be qualified for a learned profession, or for employment as a teacher in the higher schools and universities, it is necessary to have completed the university course and to have graduated. In the German empire in 1873 there were 21 universities, with 1,734 professors and 18,858 students.—The classification of schools in Austria is similar to that in Prussia. The school law of 1869 provides that in every common elementary school (*allgemeine Volksschule*) at least the following subjects shall be taught: religion, language, arithmetic, the most necessary elements of natural philosophy, geography and history, with particular regard to the country and its constitution, writing, geometrical forms, singing, and gymnastics. Girls shall also be instructed in needlework and housekeeping. The plan of instruction is determined by the minister of education, on the recommendation of the provincial school boards. Religious instruction is cared for and superintended by the respective church boards. The time required

to complete the course in these schools is eight years. The obligation to attend begins with the 7th year and lasts until the 14th is completed. Parents or their substitutes, as well as the owners of factories and industrial establishments, are responsible for the attendance of children, which may be enforced. The law provides that "the obligation to establish schools shall be regulated by the provincial legislature, on the principle that a school under any circumstances must be established in every locality, where, in a circuit of one hour's walk, on an average of five years, more than 40 children can be found who have now to attend a school more distant than one hour's walk. For children in manufacturing establishments who may be prevented from attending the common school, the proprietors of such factory, &c., shall establish, either by themselves or in connection with other manufactories, separate schools of the same grade as the public schools." All schools and educational institutions founded or supported wholly or entirely by the state, by a province, or by municipalities, are accessible to all citizens of the state, without regard to creed. A well organized system of inspection extends to every grade of instruction. The institutions for secondary and superior instruction are similar to those in Prussia. Austria has 4 universities, with (1873) 443 professors and 5,382 students. The institutions devoted to education in special branches comprise theological seminaries, schools of surgery, higher commercial colleges, polytechnic schools, nautical schools, schools of midwifery, of mining, of forestry, of agriculture and horticulture, military schools, conservatories of music, academies of fine arts, and a school of industrial art.—The rigid supervision exercised by the government over education in Germany is perhaps most marked in the measures adopted to secure efficient teachers. The teacher, being trained, examined, appointed, and paid by the government, is regarded as an officer of the government. He is virtually exempt from military service, and is entitled to a pension when no longer able to teach. No person is appointed as teacher who is not in good standing in the church, Lutheran, Catholic, or Jewish. The teachers' seminaries or normal schools are of two grades, designed for the training of teachers for the lower primary schools of the rural districts, and the burgher and other higher schools of the cities. There are separate schools for males and for females. Each one consists of the professional or normal school proper and a primary model school, or school of practice. The number of pupils in each school is limited to about 70, who are admitted by competitive examination, which is open to all over 17 (in some states 18) years of age, who possess certificates as to character, health, natural aptitude, &c. Before being admitted, the candidate must sign an agreement to teach for three years after completing the course in the seminary, or to pay the whole cost of his education therein. The course of

study is usually three years, and embraces religious, intellectual, and industrial instruction. Frequent examinations are held as a test of progress. The study of music and drawing and practice in the art of teaching are more prominent features perhaps than in any other country. For a more comprehensive education of teachers special courses are established in some of the universities and technical schools, and their improvement is further provided for by means of educational journals, libraries for teachers, periodical conferences for teachers, and special courses for professional improvement. In no other country has the kindergarten been so successfully established as in Germany. This institution, originated by Fröbel, provides for the education of infants between the nursery and the school by means of plays, games, stories, conversations, singing, and other simple exercises adapted to the nature of the child. Much importance is also attached to object teaching, which is a continuation of the kindergarten, and designed especially to develop the perceptive faculties. The kindergarten has also been introduced into Italy and other continental countries and the United States. Many of the seminaries of Germany for training female teachers have departments for the preparation of teachers for the kindergarten. Another important feature of the German system is the numerous schools open evenings and Sundays for adults who are unable to attend the ordinary schools.—In France, as in Germany, every grade of public instruction is under the direct control of the government, which acts through the minister and superior council of public instruction. This council under the late empire consisted of the minister, three senators, five bishops or archbishops, three councillors of state, three members of the court of appeals, eight inspectors general, three clergymen (Lutheran, Reformed, and Jewish), five members of the institute, and two heads of private educational establishments. The schools are classified as—1, primary, including all elementary and the lowest grade of normal schools; 2, secondary, comprising the communal colleges, lycées, and the second grade of normal schools; 3, superior, comprising the academies. To insure a high standard of excellence in the schools of every grade, a rigid system of inspection prevails. Every commune is required to establish and maintain schools for primary instruction, and is aided by the government whenever the school fees and local taxes are insufficient. Instruction in religion is given in all public schools, but no pupil is obliged to receive instruction in any creed against the wish of his parents. Private schools are encouraged, but instructors in these must pass the examinations required of those serving in the public schools; and the proficiency of their pupils and their general management are subject to governmental supervision. The lycées are founded and maintained by the state with the coöperation of the departments and

towns, while the communal colleges are founded and maintained by the communes. The arrangement of classes and studies is fixed by the government, and is the same in both. Superior education is provided for by the academies, of which there are 15 in France proper, each constituting the educational centre of an academy district and embracing several departments of the country. These institutions correspond to the universities of other countries, though many of them are inferior to the German universities. A complete academy embraces the five faculties of sciences, letters, theology, law, and medicine. Only the academy of Paris, however, includes all these faculties. All have faculties of letters and science, five of theology, ten of law, and two of medicine. The affairs of each academy, including all superior and secondary institutions of the district properly subordinate to the minister of public instruction, are managed by an academic council. Under the empire this consisted of the rector as president, the academy inspectors (one for each department in the academic district, except in Paris, where there were eight), the heads of faculties, known as deans, and seven additional members appointed triennially by the minister, and including an archbishop or bishop of the district, two ministers of the Catholic, Protestant, or Jewish church, two magisterial officers, and two public functionaries or other notable persons of the district. The degrees conferred by all the faculties are those of bachelor, licentiate, and doctor. Besides the academies, there are numerous institutions of great excellence in France for advanced education, among which may be mentioned the *collège de France* in Paris; the *école des chartes*; the museum of natural history; the school of living oriental languages, with chairs of learned Arabic, vulgar Arabic, Persian, Turkish, Armenian, modern Greek, Hindostanee, modern Chinese, Malay and Javanese, Algerian Arabic, Thibetan, and Japanese; the school of Athens, &c. All these institutions, with the chief public libraries of Paris, are under the supervision of the minister of public instruction. In like manner the special schools are under the supervision of the different ministries. Thus the minister of war has the supervision of the polytechnic school, the military school of Saint Cyr, and the cavalry school of Saumur; the minister of marine, of the naval school and the schools of hydrography; the minister of finance, of the school of woodcraft (*école forestière*); the minister of the household, of the school of fine arts; the minister of agriculture, commerce, and public works, of the schools of agriculture, veterinary science, arts and trades, arts and manufactures, commerce, mines and miners, &c. Applicants for the position of teacher in any of the public schools of France must prove their qualifications by rigid examinations regulated by the government. The educational



system of France has recently undergone some changes, and is now in a transitional state. In 1871 Jules Simon, minister of public instruction, brought before the assembly a new school law which had been approved by the council of ministers. It made attendance upon the schools obligatory, and provided for the disfranchisement after 1880 of those electors who have not attended school, or cannot read or write. Rules were laid down for the inspection of schools and the employment of teachers. The expenses for elementary education were, in the first place, to be met by the municipalities and the departments, and aid to be granted by the general government only in extraordinary cases. In every department a teachers' seminary for males and females was to be established, supported by the government. Jules Simon having been succeeded by M. Babinet, these reforms have not been realized.—The English system of public instruction has until recently, as before mentioned, been remarkable for its complete independence of the government and want of national organization. While in Germany the organization and entire control of all schools for general instruction is assumed by the government, and in the United States all the common schools are supported and controlled by the people under the supervision of the state, and open to all classes without charge for tuition, in England these important interests have been left to individuals and corporations. Except the pauper schools and those belonging to naval, military, and penal establishments, no schools have been organized by the government, nor has their management been vested in the government. It has, however, made conditional grants in aid of popular education. These grants were of two kinds: 1, to aid in establishing schools; 2, annual grants conditional upon the attendance and proficiency of the scholars, the qualifications of the teachers, and the state of the schools. All schools receiving grants were subject to yearly examination by government inspectors. In 1870 a new school system was established by the government, which, though far from being complete, was an important improvement upon the existing one, and may lead to a comprehensive system of national instruction. This measure provides for the annual grant by parliament of a sum of money to secure the establishment and maintenance, in every school district, of public schools sufficient for the elementary instruction of all the children resident therein whose education is not otherwise provided for. This fund is administered by the department of education, at the head of which is the lord president of the council on education. Two classes of schools come within the provisions of the act: 1, elementary schools, which comprise those where the principal part of the instruction is elementary, and not including any school or department where the tuition exceeds ninepence a week; 2, training schools to qualify teachers for the elementary schools. The grant

is given annually to managers of schools, and is intended to aid voluntary local action in the establishment of new schools and the maintenance of existing ones. It is made only on certain conditions, the chief of which are that no child shall be refused admission except on reasonable grounds; sectarian religious exercises shall not be required of any pupil; certificated teachers must be employed except in the evening schools; and the schools must be open to the government inspectors. School boards, composed of not less than 5 nor more than 15 members, intrusted with seeing that the provisions of the law are complied with, are elected in boroughs by the burgesses, and in parishes not within the metropolis by the rate payers. They are permitted to enforce the attendance of children between the ages of 5 and 13 years. Special provision is made for the election of school boards in London. All school expenses are paid out of the school fund, which consists of fees, parliamentary grants, loans, &c. All children whose parents are unable to pay for their education shall be admitted free to these elementary schools. Under the new law, schools which have met not less than 400 times in the morning and afternoon during the year may claim 6s. per student, according to the average number in attendance throughout the year; for every scholar present on the day of examination who has attended not less than 150 morning and afternoon meetings, if above 4 and under 7 years of age, 8s.; or 10s., if the infants are taught in a separate department; if more than 7 years of age, 12s., subject to passing an examination in reading, writing, and arithmetic. The managers of evening schools which have met not less than 80 times during the year may claim 4s. per student, according to the average number in attendance throughout the year, and 7s. 6d. for each one who has attended not less than 50 evening sessions, subject to a successful examination in reading, writing, and arithmetic. Provision is made for the individual examination of students upon certain standards clearly defined for each grade of schools. The parliamentary grant to popular education in Great Britain was £1,093,624 in 1871, and £1,551,560 in 1872. The importance of training schools for teachers is recognized in the new school law, and government aid is extended to this class of institutions on the same conditions as to the public elementary schools. Provision is also made for training and employing "pupil teachers." A training school includes a college for boarding, lodging, and instructing candidates for teachers in the elementary schools, and a practising department to afford training in the art of teaching. Admission is by competitive examination open to all who intend to adopt teaching as a profession, and have either served the apprenticeship of pupil-teachers or are over 18 years of age. The course of study is two years. To obtain certificates teachers must be examined and must undergo probation by actual service. It will

be noticed that the above described supervision by the government applies only to the lower grade of schools in England and Wales, and only to such as choose to comply with the conditions laid down. Higher instruction is afforded by the great body of endowed schools, including grammar schools and colleges, and by the universities. In the former, which are the middle schools of England, students are fitted for the universities. They are attended largely by the wealthier classes; and the studies are chiefly classical. In England there are the universities of Oxford, Cambridge, Durham, and London; there are four in Scotland, and two in Ireland. The most famous of these are Oxford and Cambridge, which have been richly endowed by the government and by individuals. Both are corporations comprising numerous colleges (Oxford 24, Cambridge 17), each college being a distinct organization with its own governing body. Instruction is administered by tutors, and examinations are held for degrees. In 1869 a bill was passed bringing all the educational endowments of England under the supervision of the department of education. The educational interests of Ireland are under the supervision of a board of commissioners for national education; but there is no educational division of the country, and no public tax for school purposes. Parliamentary grants are made in aid of popular education on certain conditions, and a vigorous system of inspection by government commissioners prevails. The parliamentary grants for popular education amounted in 1872 to £430,390.—The Swedish system embraces the usual classes of schools. A *folk skola*, or school for the common people, is required to be maintained in each *socken* or parish, of which there are more than 2,000. Instruction is gratuitous, the schools being supported by direct government grants and local taxation. Children between the ages of 9 and 15, who are not otherwise receiving instruction, must attend these schools, under penalty of separation from their parents; but this is seldom enforced. A prominent feature in the management of these schools is the power vested in the clergy. Educational matters in a parish are controlled by the church meeting (*kyrko-stämman*), which is presided over by the pastor and composed of tax-paying parishioners who belong to the established church. Inspectors are appointed by the ecclesiastical department, on the recommendation of the bishop of the diocese in which they are to act. In the selection of teachers special regard is paid to their religious sentiments. Where fixed schools are impracticable, "ambulatory" schools have been provided for, whose teachers travel from one farm to another, instructing the children of the peasants. In the folk schools prominence is given to religious instruction (Biblical history and the catechism), drawing, singing, military exercises, and gymnastics. There are 10 higher folk schools designed to afford a

somewhat more advanced course of study to children of the common classes. The studies are proposed by the parents and teachers, and determined by the bishop and rector. The state annually appropriates 1,000 rix dollars (\$265) for each school. Tuition is gratuitous. Between the folk school and the university are the higher elementary, the lower elementary, the pedagogical schools, and the normal schools. There are 31 schools for higher elementary instruction, one or more being established in every *stift* or diocese, sustained by appropriations out of the state treasury. These institutions afford complete preparation for the university, corresponding to the gymnasia of Germany and the grammar schools of England. There are two courses of study, the classical and the practical, and seven annual classes. The power of appointing all the teachers of these schools is virtually with the bishops. Each school has a principal called the rector, who is assisted by about five lecturers or teachers, who must at least have had the degree of master of arts before appointment; there are also from seven to fifteen assistants, who must be graduates of the university, besides three or more teachers of music, drawing, military tactics, and gymnastics. Each school has an inspector who is appointed by the bishop. The usual fee paid by each pupil is about 10 rix dollars (\$2 60) for the term of eight months. The lower elementary schools differ from those above described chiefly in the number of classes. Each school has an inspector, a rector, and from one to five assistant teachers, all appointed by the bishop. A small tuition fee is paid. The pedagogical schools are inferior to the lower elementary. These are in the smaller towns, are exclusively for boys, and are supported by appropriations out of the state treasury. There are nine normal schools, seven for males and two for females. Instruction is gratuitous; the course is three years. To each is attached a school for practising the art of teaching. The private schools of Sweden are under the same inspection that the government requires for elementary schools. With the exception of one seminary and two normal schools for the training of female teachers, no provision exists for the instruction of girls beyond what is afforded in the folk schools. Sweden has two ancient and famous universities: that of Upsal, with 100 professors and tutors and about 1,500 students, and that of Lund, with 75 professors and tutors and about 500 students. In the former the course of study varies from three to six years, the faculties being the same as in the German universities. All public lectures are free. The other educational institutions of Sweden embrace folk high schools for the instruction of children and adults in business, politics, and the duties of life; an institution for the deaf, dumb, and blind in Stockholm; agricultural institutes and schools, which receive some aid from the government, but are principally self-

sustaining; an institute and schools for instruction in maintaining and stocking forests; industrial and trade schools; schools for drawing and designing; navigation schools, and an institute for ship building. The government grants aid to numerous scientific and art academies, a medical school, two veterinary institutes, a military, and a naval school.—Since 1814, when Norway regained its independence, the system of education has received careful attention, and the various reforms in it attest the democratic spirit which pervades the Norwegian institutions and constitutes their strength. Its educational institutions may be divided into five classes: 1, common schools; 2, grammar and high schools; 3, Latin schools, and combined Latin and high schools; 4, the university; 5, schools for special branches. The first class comprise common schools in the country and those in towns. The former include "lower schools," in which children belonging to a circle of the district receive instruction either voluntary or compulsory, and "higher schools," comprehending several circles or districts, in which the children receive a more complete education. The law requires that wherever there are 30 children, legally bound to attend school, living so near each other as to be able to attend the same school daily, a common school shall be established. In districts where a small population is scattered over a surface of several miles, "ambulatory schools" have been established. Where even these are impracticable, the law requires that instruction shall be provided in some other manner. The school committee is empowered to establish schools for children under the school age, which may be conducted by female teachers, and also sewing schools and other industrial schools. Manufactories and other industrial establishments are obliged to provide a school for the children of their workmen. The establishment of lower common schools is obligatory on the school districts, but that of the higher schools is optional. It is provided that there shall be at least one common school in every town. The branches of instruction in these are almost the same as in the rural schools, and embrace reading, knowledge of the Christian religion, selected parts of the reading book (which is published by the government and is the same in all these schools), chiefly such as relate to history, geography, and knowledge of nature, singing, writing, arithmetic, gymnastics, and military exercises. Attendance on the common schools 12 weeks annually is obligatory for all children living in the country, from the 8th year (in the towns from the 7th year) till the time of their confirmation, unless otherwise instructed, under penalty of fine and separation from their parents. The school committee, however, may allow the child to leave school at the age of 13, if sufficiently advanced in instruction. Once a year a public examination of the pupils in the common schools is held, in the presence

of the pastor and other members of the school committee. All children above nine years of age who are bound to attend school must take part in it, even those receiving private instruction corresponding to that of the common schools. As a rule the primary instruction is free. Each municipal district forms a school district, and has a school fund common to the several circles into which a district may be divided. The municipal council grants the money in all school matters, determines the amount of school expenditures, and apportions the school tax, which is sometimes distributed among all the families of the district, but generally assessed on the residents in proportion to their fortune. All the school districts belonging to the same province form together a higher school district and have a common fund. A normal school has been established by the government in each of the six dioceses. They are under the supervision of the government, and their teachers are appointed by the king. Connected with each normal school is a children's school to exercise the normal pupils as teachers. In addition to these, there are smaller institutes for teachers, either as parallel classes of a higher common school, or as a higher class of a public common school. The so-called higher or civic schools differ chiefly from the best arranged common schools in the addition of modern foreign languages, and in giving a fuller instruction in other branches. Some of these schools also prepare pupils for the university. They are supported by the municipalities, or at least guaranteed by the towns in case the pupils pay for their tuition. Most of them are exclusively for boys, some for both boys and girls, and two are exclusively for girls. Many of these schools are under the inspection of the superintendents of the diocese, and some are supported by the educational fund, which now amounts to more than 3,000,000 specie dollars (\$3,335,000). This fund owes its origin to the sale of large estates formerly bequeathed to the clergy and churches. The Latin schools and combined Latin and high civic schools are in the principal towns and belong to the state. They afford a higher general education, intended to prepare students by classical studies for the university, or by the study of natural sciences for practical life. The greater part of these schools are partly supported by contributions from the state and the town. The pupils pay for tuition in all of them. Until quite recently particular attention has been paid to the study of the classics, but public opinion has compelled a reduction in those studies and a proportionate increase in the study of modern languages and natural science; and the old Norse tongue and English have been made obligatory studies. The highest instruction is afforded by the university in Christiania, which has the five faculties of theology, law, medicine, history and philosophy, and mathematics and natural science, with about 50 professors and 1,000

students. The lectures are gratuitous, and the students are not bound to any fixed term of study. The special educational establishments of Norway comprise asylums for very small children in the towns and Sunday schools (for secular instruction), which are chiefly supported through private liberality; the peasants' high schools, copied from the Danish system; agricultural schools in most of the provinces, supported by the state and the various districts; nautical schools established by the government in the towns along the coast to educate captains for the commercial marine; a military college for the training of army officers, a naval school, a military high school for the education of engineers and artillery officers, and a school for engineers recently founded by the government.—In Denmark popular education has been provided for and fostered by the government for more than 300 years. The general control of this interest is vested in a minister of public instruction and subordinate superintendents for the several departments of the kingdom. Each parish is obliged to furnish good primary-school buildings, with teachers for the instruction of children in reading, writing, arithmetic, the Lutheran catechism, grammar, history, and geography. There are normal schools for the training of teachers, which add to these primary branches studies in mathematics, the natural sciences, the art of teaching, gymnastics, drawing, and music. About six years are devoted to secondary instruction, the studies being similar to those of the German gymnasium. In the four lower classes choice of studies is given to students; in the two higher the instruction is divided into two coördinate divisions, one devoted to philological and historical studies, and the other to mathematics and natural science. Old Norse, Danish, French, English, and history are taught in both divisions. More than 70 farmers' high schools (*Folkhøiskoler*) have been founded for the purpose of elevating the standard of education among the rural population and making them acquainted with the national history and literature. They are supported by private means, aided by the government. These schools have also been introduced into Sweden and Norway, where they have attracted much attention. Superior education is afforded by the university of Copenhagen, founded in 1478, which has faculties of theology, law and political science, medicine, philosophy, and mathematics and natural science. Instruction is given to more than 1,000 students by about 80 professors and docents.—In the Netherlands the plan of education is threefold: primary, embracing the elementary schools of various grades, normal schools, evening schools, &c.; secondary, including the burgher schools, agricultural, polytechnic, and navigation schools, institutions for deaf mutes and blind, schools for nurses, and schools of veterinary surgery; superior, comprising the universities, athenæums, Latin schools, and

gymnasias. There are also schools and academies for the army and navy, prison schools, and infant schools. Educational matters are under the control of the minister of the interior. The 11 provinces are divided into 89 school districts, and these into communes, in each of which there must be a primary school under the charge of a local board; and each commune of 3,000 persons has a school commission. For each district there is an overseer, who is chairman of all the commissions within his jurisdiction. At the head of the districts of each province is a provincial inspector, salaried by the state, whose duty it is to superintend all the schools in his province, receive the reports of district overseers, and once a year to sit in the council of provincial inspectors under the presidency of the minister for the consideration of the general interests of primary schools throughout the kingdom. Each commune must support a sufficient number of primary schools, or, if it is unable, the province and the state must share equally the expense. Primary schools must be open throughout the year, excepting on holidays. Attendance is not obligatory, but parents are denied aid from charitable institutions if their children have not been instructed in the elements of a popular education. An educational society has been formed, with branches all over the country, whose object is to use all moral means possible to induce parents to send their children to school. It also aims to secure the enactment of a law prohibiting the employment in factories of children below the age of 12. A regular school fee is generally paid in the private and public day schools, but in the case of poor parents an exception is made. About one half of the children attending schools are instructed free. Numerous schools for adults are maintained. There are both public and private normal schools and normal classes. There are three government normal schools; the course of instruction occupies four years, with from 39 to 44 hours a week. In all the provinces of the Netherlands there is a large number of evening schools, kept partly for the benefit of pupils of the day schools who wish more extended opportunities for study, and partly for the benefit of young persons employed in stores and factories. The plan of instruction in the higher burgher schools embraces the following studies: natural philosophy, chemistry, natural history, mathematics, the Dutch, French, English, German, and Italian languages, political economy and statistics, bookkeeping, commercial law, knowledge of goods, commercial arithmetic and weights and measures, general history and history of commerce, general and commercial geography, constitution and laws of the Netherlands, history, geography, &c., of India, penmanship, and free-hand drawing. Among the other institutions for secondary instruction are two, one government at Leyden and one municipal at Delft, for the preparation of civil offi-

cers for Dutch India, affording instruction in the Javan and Malay languages, Mohammedan law, the institutions, religions, geography, history, ethnology, and statistics of Dutch India. Holland is rich in educational institutions for the army and navy. Provision is also made for instruction to the inmates of prisons; and there are special schools for the instruction of children between the ages of 4 and 6. Superior instruction is provided for by three universities, Utrecht, Leyden, and Groningen; two athenæums, Amsterdam and Deventer; and 55 gymnasia and Latin schools. The universities have five faculties each: theology, law, medicine, mathematics and natural sciences, and literature. The athenæums have the same faculties and the same course of instruction as the universities; the only difference between them is that the athenæum is not a government but a municipal institution, though under government supervision. The gymnasia and Latin schools afford a classical and mathematical education to students preparing for the universities and professional schools.—The Swiss system of popular education bears a general resemblance to that of the United States. There is, in fact, no national system, but each canton has its own system complete. The administration of educational affairs rests primarily in the cantonal minister of public instruction, aided by a board of three or more members elected from the communes or sections, which are the only school divisions known to the canton. The gradation of the schools and plan of inspection are essentially German. The communal inspectors report to the cantonal, and these to the minister, whatever relates to the fulfilment or evasion of the law and the general condition of the schools. Attendance is obligatory in all but four of the cantons, unless it be shown that children are receiving equally good instruction in private schools or at home; and even then, such children must undergo examinations. In some of the cantons the prescribed school age is from 7 to 14, in others from 6 to 16. The schools are maintained by taxation. Gymnastic and military exercises form a prominent feature, and to provide competent teachers young men are sent by the government to receive instruction in the great gymnastic establishment in Dresden. There are three Swiss universities, situated at Basel, Bern, and Zürich. These are cantonal rather than national, and are organized after the general plan of the German university, but are of inferior rank.—In Italy all matters pertaining to education are under the control of the ministry of public instruction, which has six divisions or bureaus. The first is the financial bureau, through which the payments to all the institutions dependent on the ministry are made; the second has the administration, and gathers the statistics of all the institutions for the fine arts and antiquities, the musical institutions, the libraries, archives, the scientific and literary academies; the third

has the superior instruction, universities, schools for engineers, schools for veterinary surgery, and astronomical observatories; the fourth the institutions for secondary instruction; the fifth the institutions for primary instruction; and the sixth is the auditor's office, through which also all communications to and from the royal court of accounts are transmitted. Elementary education in Italy has been very backward, but the whole system of public instruction is now undergoing a thorough reorganization. The new school law provides for elementary instruction to be given everywhere free of charge, for obligatory attendance upon the schools under penalty of fine, and that no one shall be appointed to any state, provincial, or communal office who cannot read and write.—In China, more than in any other country, with perhaps the exception of Prussia, a learned education is the means of official promotion. Instruction begins in the family, where the boys are taught to enumerate objects, to count to the number of 10,000, and to reverence their parents and ancestors by a minute ceremonial. At the age of 5 or 6 they are sent to school. For the sons of the nobles a higher course of instruction is provided in universities under the surveillance of the state. One of these exists in most of the large cities, and the most advanced of them is the imperial college in Peking. Candidates for admission into this institution are required to pass a strict examination, and the graduates from it are at once appointed to public office. The education of girls is neglected, but the daughters of the wealthy are generally taught to read, write, sing, and sometimes to make verses. For a more complete account of education in this country, see CHINA.—The new school law of Japan, when carried out, will secure a thorough system of education for that country. According to its provisions, the management of educational affairs throughout the country is vested in one central authority, the department of education. For educational purposes the empire will be divided into eight grand divisions, called collegiate, which will be subdivided into 256 academical districts, each to contain a middle or high school, and these again into 53,760 school districts, with one school each. There shall be appointed in every academical district by the local authorities from 10 to 13 directors, each to control from 20 to 30 schools. Every child of all classes must be sent to school from the age of 6 years, and continue long enough at least to finish the elementary course. There are to be three classes of schools: great learning (superior), middle learning (secondary), and small learning (elementary). The different grades of elementary schools embrace common, girls', village, charity, private, infant, and evening schools, and schools for imbeciles. The common (public) schools will have two grades; in the lower will be taught spelling, writing, conversation, vocabularies, reading, morality, letter-writing, grammar, arithmetic, lessons on

health, outlines of geography and of natural history, and gymnastic exercises; in the upper, the outlines of history, geometry, trigonometry, botany, chemistry, and physiology. One or two foreign languages, bookkeeping, drawing, and political economy may also be taught. The lower grade is for children between 6 and 9 years of age, and the upper for those between 10 and 13. The secondary schools, or academies, are intended to afford instruction in the ordinary college branches to those between 14 and 18 years of age. In this grade are also agricultural academies, foreign languages for those preparing for commercial pursuits, and industrial academies. The superior schools will afford instruction in the professional branches, logic, literature, law, and medicine. Normal schools will be established to provide teachers for the public schools. Provision is made for sending about 180 students abroad to receive advanced instruction at the expense of the government. In every class of schools a tuition fee must be paid. The educational funds are under the exclusive control of the department of education.—In the United States the regulation of all matters pertaining to education is left entirely to the states, each of which maintains a system of public instruction independently of the others. These systems differ mainly in details, while the general features are common to all, and give to public instruction in the United States an individuality which distinguishes it from the educational systems of all other countries. In each state instruction is provided by law for all persons of school age, free of all charge for tuition. Attendance is not generally obligatory, but there is a rapidly increasing tendency among educators toward the recognition of the right and duty of the state to educate its entire school population. New Hampshire, Massachusetts, Connecticut, Michigan, and Nevada have laws requiring parents to send their children to school during a specified period between certain ages. The public schools are established and controlled entirely by the people through their chosen officers, and are supported chiefly by voluntary taxation, but partly by funds derived from the sale of government lands and from the gifts of individuals. These schools are entirely independent of any religious organization, and sectarian instruction is carefully avoided; the Bible, however, is generally read in them as a daily exercise. The school system of each state is adopted and all changes therein made by the legislature. The general supervision and control of the educational interests of the state are vested in a board of education or superintendent of public instruction, who are generally elected by the people or appointed by the governor and legislature, and receive a salary. The powers and duties of these officers vary greatly in the different states. The state superintendent generally has his office at the state capital, where he receives reports from the various school districts and local superintendents,

showing how many months of the year each school has continued, how many children have attended, what has been the success of the methods employed, and what is the condition of the schools in every district. This information is embodied in an annual report to the governor or legislature, and distributed among the people. The superintendent has also a sort of judicial supervision of all matters pertaining to schools, is appealed to for the construction of the law, and acts generally for the stimulation and advancement of education. For purposes of local government each state is divided into counties, which are subdivided into towns or townships; a further division of the towns is made into districts of a size suitable for the maintenance of a school. Of these school districts there are 11,350 in the state of New York, and about 167,800 in the United States. In each of them a school is maintained for the accommodation of all the children in the district. In each district officers are chosen by the people who have charge of the school property, employ teachers, provide furniture, fuel, and sometimes books, and have power to levy taxes to meet any expenses that may accrue. In each county there is generally a board of trustees or one or more superintendents or commissioners of public schools chosen by the people to look after their educational interests. Besides these, visitors or inspectors are appointed in each school district or town to inspect the schools and conduct examinations at intervals. By the above mentioned officials all matters pertaining to public instruction are administered, embracing the construction of school houses, the choice of text books and other means for instruction, the examination and appointment of teachers, matters of discipline, the best systems of teaching, and in general whatever may lead to the best results in public instruction. It will be seen that the general supervision of the system is exercised by the state, while the details are determined by the subordinate districts, thus securing local responsibility under state supervision. In the larger cities special provision is usually made vesting the management of the schools in a board of education and a superintendent of public schools. In cities and the larger towns the public schools are graded into primary, grammar, and high schools. The schools are generally open five or six hours a day and about 40 weeks during the year in the cities, but a much less time on the average in rural districts. The school age varies in different states, ranging from 4 to 21 years. After passing through the primary grade, where the ordinary elementary branches are taught, including frequently vocal music, the pupil enters the grammar school, where, in addition to the ordinary branches, music, French, German, drawing, natural philosophy, and chemistry are taught. The time required to pass through these two grades averages about eight years. At this point the education of many pupils ceases, while others

continue through the high schools, where the course of instruction occupies from three to five years, and embraces generally the ancient and modern languages, the higher mathematics, philosophy, &c. In 1872 statistics were collected by the United States bureau of education showing the extent to which music, drawing, French, and German were taught in the public schools of cities containing 10,000 or more inhabitants. Reports were received from 140 cities, from which it appears that the study of vocal music is almost universal in schools of all grades, but only three cities reported instrumental music as among the branches taught in the public schools. Drawing was taught in all the schools of 47 cities, in the high of 4, in the high and grammar of 12, in the grammar of 3, and in the grammar and lower grades of 24; making 90 cities in which drawing was reported as among the studies. German was reported to be taught in 76 cities, viz.: in all the schools of 15, in the high of 33, in the high and grammar of 20, in the grammar of 4, and in the lower grades of 4. Instruction in French was provided by 73 cities; it was a regular study in all the schools of 2, in the high of 63, in the high and grammar of 7, and in the grammar of 1. In some of the cities, and especially in the rural districts, the same schools are attended by both sexes; but in most of the larger cities, especially in the higher grades of schools, separate schools are maintained for boys and for girls. In regard to color, in some instances, no distinction is made in the admissions to the public schools, but more generally colored pupils are required to attend schools specially provided for them. In all the schools pupils pass from a lower to a higher grade after an examination, oral and written, in the studies pursued. These examinations are sometimes conducted by the teacher, but more frequently by other school officers, such as the superintendent of schools or a member of the board of visitors.—In nearly every state there is a normal school for the preparation of teachers; in several, three or four; and in New York, eight. The course of instruction usually occupies two, but sometimes three years, upon the completion of which diplomas or certificates are conferred, which are generally accepted as evidence of qualification to teach in the public schools without further examination. In the absence of such certificates, applicants before being chosen as teachers are required to pass an examination conducted by school officers appointed for that purpose. In many states the system of examining teachers is very deficient. In California a great advance has been made in this respect. State and county boards of examination, composed exclusively of professional teachers, have been organized. The system embraces written examinations and the issue of graded certificates to teach, from life certificates down to limited certificates for temporary teachers. According

to the report of the bureau of education for 1872, there were 101 normal schools in the United States, with 773 instructors and 11,778 students. Of these, 48 schools, with 454 instructors and 7,157 students, were supported or aided by states; 2, with 9 instructors and 182 students, by counties; 7, with 72 instructors and 816 students, by cities; 44, with 248 instructors and 3,623 students, are connected with other educational institutions. In 66 of these schools drawing is taught, and 16 have collections of models, casts, apparatus, and examples for free-hand drawing; vocal music is reported as taught in 74, and instrumental music in 51; 45 possess chemical laboratories, 52 philosophical cabinets and apparatus, and 32 have cabinets of natural history. Model schools are connected with 57 normal schools, and 70 confer diplomas and certificates upon students completing the course. While there has been a steady growth of normal instruction as an element in the educational system of the United States, the present provision is entirely inadequate for the training of the necessary number of teachers, the deficiency being supplied by graduates of other public and private institutions. According to an estimate made by the bureau of education, based on the assumption that teachers do not continue in service on the average more than three years, 120,897 new teachers are annually demanded in the United States, while the normal schools can supply only about 4,000.—Another most important feature of the system of education in the United States is the numerous conventions and associations of teachers and educators held for the discussion of all topics pertaining to education. These organizations are national, state, and county. In many of the states county institutes or teachers' associations are held at frequent intervals during the year, for the purpose of securing a higher degree of efficiency among the teachers by means of lectures and other forms of instruction given by experienced educators, and discussions by teachers themselves. The state organization of teachers usually meets annually, sometimes oftener, under the direction of the state school officers, for the consideration and advancement of the educational interests of the state. The national educational association is composed of the foremost teachers and educators in every department of learning, and meets annually for the discussion of whatever may tend to promote education in any of its branches in the United States. This body, which held its 13th annual session in 1873, comprises four departments: elementary, normal, superintendence, and higher instruction. Besides this, the American institute of instruction meets annually for similar purposes, and there are other national educational associations. In the United States the plan of the school house is recognized as an important element in the system of education, and much attention is given to secure the best models in regard to light, ventilation, location, and other de-

tails affecting the health, comfort, and mental activity of the student. The organization of free evening schools as a part of the system of public instruction is of comparatively recent origin, but the growth in their number and efficiency has been marked. They are provided chiefly in the large cities and manufacturing districts, and are intended to afford instruction in the ordinary branches to those adults and others who are prevented by employment from attending the day schools. Of the 141 cities having 10,000 or more inhabitants that reported to the bureau of education in 1872, 51 had 218 evening schools, with 1,350 teachers and 60,297 pupils; of 82 cities with a population between 5,000 and 10,000, 7 were reported as having 14 schools of this class, with 20 teachers and 555 students; while of 103 cities having less than 5,000 inhabitants, 7 reported 9 evening schools with 312 pupils. —In addition to the public schools, private schools for all grades and classes of students are extensively encouraged and patronized. In this manner many denominational schools are supported, especially by the Roman Catholics. So far as the state is concerned in the control and support of education, public instruction is generally limited to the common schools, embracing the primary, grammar, and high, including academies; and beyond the last named grade means for education in most instances is dependent upon individual or corporate provision. Institutions of the highest class, such as universities, colleges, schools of science, &c., are in a few of the states maintained at the public expense; but in most they are supported by income from tuition and by endowments under the direction of private corporations, which are exempted from taxation. Where tuition is charged, the rate is always low. Institutions of this class are everywhere protected and encouraged by favorable laws and charters. No definite line of classification can be drawn separating universities, colleges, academies, and seminaries for advanced instruction. The mode of organization and government, and the system of instruction, are often the same in an academy as in a college or university. Nor is there any standard of requirements to determine whether an institution shall be admitted to either of these classes. Consequently the variety among colleges, for example, as far as concerns the endowment of the institution, the number of instructors and pupils, the extent and thoroughness of instruction, and the general facilities for affording advanced education, may be so great as to suggest no comparison or similarity. Many institutions, therefore, assuming the name of college or university, are insignificant in comparison with the best institutions of that class. The representative American college is a corporation deriving its charter and powers from the state, and supported by endowment and funds arising from gifts, tuition, &c. Its external adminis-

tration is vested in a board of overseers or trustees, some of whom are appointed by the state, while it is governed more immediately by a faculty composed of professors and instructors. The chief executive officer is a president, generally chosen by the overseers or trustees. The course of study extends through four years, and embraces the ordinary branches of advanced learning, such as ancient and modern languages, mathematics, the sciences, philosophy, logic, &c. Students are admitted at from 16 to 18 years of age, after examination. In most colleges all the studies are required, while in others the student has a choice of different branches. Instruction is administered by recitations and lectures, chiefly the former. Written and oral examinations are frequent, and annual written examinations are held as a condition of passing from a lower to a higher class, there being four classes in all. Degrees are conferred upon those students who pass a successful written examination which is frequently limited, however, to the studies of the last year of the course. Discipline and attention to study are secured by a graded system of marks of merit and demerit. Many of these institutions have various funds for indigent and meritorious students, consisting of prizes, loans, scholarships, &c., arising from gifts by individuals. In some cases a student may defray the expenses of his education from these sources. The degree usually conferred at graduation is that of bachelor (A. B.), while the master's degree (A. M.) is conferred three years later, the only condition except at Harvard being the payment of a fee. The degree of bachelor in the various professional and scientific departments is also conferred, while doctor of divinity (D. D.) and doctor of laws (LL. D.) are granted as honorary degrees. In the United States there is no university or university instruction according to the European classification, especially that adopted in Germany. There are, however, more than 100 organizations that assume that title, which may be divided into three general classes: denominational universities, founded and managed by religious sects; non-sectarian, which, though in the main independent, are partly endowed and controlled by the state; and those originally founded and wholly controlled by the state. Several institutions, however, partake of the university character, such as Harvard and Cornell universities and Yale and Columbia colleges, whose organizations embrace, besides the academic department, professional and technical schools with numerous professorships, libraries, museums, collections, apparatus, &c., for the most advanced instruction. The oldest and most completely developed institution of this class is Harvard university in Cambridge, Mass., which may be taken as a representative of the most advanced instruction afforded in the United States. It embraces an academic department, with a four years' course of study; a divinity school, three



years; a law school, two years; a scientific school, with a four years' course in civil and topographical engineering, three years' courses in practical and theoretical chemistry, in natural history, and in mathematics, physics, and astronomy, besides teachers' courses of one year and instruction for advanced students; a school of mining and practical geology, with a four years' course; medical school, three years; an astronomical observatory, with special instruction; a dental school; a school of agriculture and horticulture; a museum of comparative zoölogy; and the Peabody museum of American archæology and ethnology. (See HARVARD UNIVERSITY.)—The United States government exercises no control over public education, and makes no regular provision for its support, except that military instruction is afforded at West Point, N. Y., in a four years' course, and also at the school of artillery, Fortress Monroe, Va., and naval instruction at Annapolis, Md., free of charge. These institutions are wholly supported and controlled by the general government, and are intended to provide trained officers for the army and navy. Liberal aid, however, has been extended by congress for purposes of education, by various grants of land dating as far back as 1803. The land granted or reserved for common schools and universities amounts to about 68,000,000 acres, in addition to which 7,830,000 acres were reserved by act of congress passed July 2, 1862, granting to the several states and territories 30,000 acres for each senator and representative in congress, to provide "colleges for the benefit of agriculture and the mechanic arts." The organization and management of these institutions are transferred to the respective states on certain conditions. In almost every state the funds thus realized have been added to those of some existing institution in order that better results may be obtained by the concentration of resources; but in such cases the government funds must be devoted to the special studies for which they were intended. In 1867 an important step, growing out of the numerous inquiries and demands by foreign educators and others for information and statistics concerning education in the United States, was taken by congress in the establishment of a department, now called the bureau of education, "for the purpose of collecting such statistics and facts as shall show the condition and progress of education in the several states and territories, and of diffusing such information respecting the organization and management of school systems and methods of teaching as shall aid the people of the United States in the establishment and maintenance of efficient school systems, and otherwise promote the cause of education throughout the country." At the head of this bureau is a commissioner who makes an annual report to congress, which is printed for gratuitous popular distribution. This report aims to present full information concerning all the educa-

tional institutions in the different states and cities, and all educational forces, such as libraries, museums, newspapers, and periodicals. It also presents a summary of the latest educational information and statistics of all parts of the world, and contains articles on various subjects connected with education. The bureau also publishes in pamphlet form reports on education in different countries. According to this authority, the total school population of the 34 states and 7 territories reporting in 1872 was 12,828,847, and the enrollment 7,379,656. In 28 states and 4 territories reporting, the average attendance was 4,110,525. The number not registered in 34 states and 6 territories reporting was 4,608,803. There were attending private schools in 18 states and 5 territories 364,283. The number of teachers reported in 33 states and 7 territories was 217,239. The total income in all the states and territories from which it is reported was \$72,630,269, of which \$55,889,790 were from taxation; total expenditure for educational purposes, \$70,891,981. In 31 states having a permanent school fund the total amount was reported at \$65,850,572. Of 326 cities in the United States, 295 reported their school population at 2,123,889; in 318, the enrollment was 1,215,897; in 298, the average attendance was 787,860; in 292, the number of schools is reported at 7,917; and in 315, the number of teachers at 23,194. The following summary of educational institutions in the United States is reported by the bureau of education for 1872:

INSTITUTIONS.	No.	Teachers.	Pupils.
Normal schools.....	101	773	11,773
Business colleges.....	66	263	8,451
Academies.....	811	4,501	98,529
Colleges.....	293	3,040	*45,617
Institutions for superior instruction of females.....	175	1,617	11,288
Schools of science endowed by national grant of lands.....	38	411	2,971
Schools of science (including collegiate departments) not so endowed..	32	313	2,443
Theological schools.....	108	435	3,351
Law schools.....	42	151	1,976
Medical schools, regular.....	61	607	4,857
"    "    eclectic.....	3	25	259
"    "    homeopathic.....	6	72	585
Dental schools.....	59	58	199
Pharmaceutical schools.....	13	36	650
Institutions for the blind.....	27	513	1,856
"    "    deaf mutes.....	86	267	4,337
Reform schools.....	26	331	4,230
Orphan asylums.....	77	852	10,324

From the United States census for 1870 it appears that of the 17,389,784 persons between 5 and 24 years of age inclusive, 7,209,938, or more than one third, were receiving instruction. As the number over 21 under instruction must be very limited, nearly one half of the population between 5 and 20 years of age, inclusive (14,507,658), are reported to be in institutions of learning. The total number of instructors

\* Unclassified, 6,694; preparatory, 19,476; collegiate, 19,249.

was 221,042, of whom 93,329 were males and 127,713 females. The total wealth of the country was \$30,068,518,507; the total income of schools, which may also be taken as the total expenditure, was \$95,402,726. Of this amount \$3,663,785 was from endowment, \$61,746,039 from taxation and public funds, and \$29,992,902 from other sources, including tuition. In the United States more than 17 per cent. of the adult males and 23 per cent. of the adult females are illiterate. In a total population of 38,558,371, 4,528,084 persons 10 years of age and over could not read, and 5,658,144, 10 years of age and over were unable to write, including 777,873 of foreign birth and 2,789,689 colored. It will thus be seen that a large portion of the illiteracy is due to those who prior to the civil war were slaves, a fact which is further illustrated by a map published by the census to show the distribution of illiteracy by states. The following statement of illiteracy has been compiled by the bureau of education from the census of 1870:

Aggregate population.....	38,558,371
Total population, 10 years old and over.....	28,238,945
Illiterate population, 10 years old and over.....	5,658,144
Male population, 10 years old and over.....	14,258,866
Illiterate males, 10 years old and over.....	2,608,888
Female population, 10 years old and over.....	13,970,079
Illiterate females, 10 years old and over.....	3,054,256
Percentage of total illiterates to total population of same age.....	20-04
Percentage of male illiterates to male population of same age.....	18-26
Percentage of female illiterates to female population of same age.....	21-87
Total population in 1870, 10-21 years old.....	9,692,945
Illiterate population, 10-21 years old.....	1,942,948
Male population, 10-21 years old.....	4,815,865
Illiterate males, 10-21 years old.....	984,741
Female population, 10-21 years old.....	4,877,080
Illiterate females, 10-21 years old.....	958,207
Percentage of illiterates, 10-21 years old, to population of same age.....	20-05
Percentage of male illiterates to male population, both 10-21 years old.....	20-45
Percentage of female illiterates to female population, both 10-21 years old.....	19-65
Total male adults, 1870.....	9,443,001
Male adult illiterates.....	1,619,147
Total female adults.....	9,092,999
Female adult illiterates.....	2,096,049
Percentage of male illiterate adults to total adults.....	17-15
Percentage of female illiterate adults to total females.....	23-05

—*Professional Education.* The system of professional education in the United States, so far as there is any system, is greatly inferior to that of continental Europe. There instruction in medicine, law, and theology is usually provided by faculties of the university, and is consequently regulated by the government. The conditions of admission and graduation are such as to secure thorough training. In the United States professional schools sometimes form departments of colleges, but are frequently independent of other educational institutions, and usually of the government. The courses of study are shorter and less thorough than in Europe, while the requirements for admission and graduation are far less. The requisites for admission to American medical schools, where any exist, can generally be met by the preparation received in a common school or academy.

The usual course of study is three years, in which are included at least two courses of lectures, when the student receives the degree of M. D. In Italy the applicant for admission to the medical school must have completed the studies of the lyceum—Greek, Latin, and Italian literature, history and geography, philosophy, chemistry, mathematics, natural history, mechanics, and gymnastics. The term of study is six years. In France the standard of admission is even higher; and to obtain the degree of doctor, which alone secures the privilege of full practice in medicine and surgery anywhere in France, the student must have completed a four years' course in one of the great faculties, or the courses in an *école préparatoire* for three and a half years, and at least one annual course in a faculty of medicine; spent two years in a hospital near the faculty or preparatory school; and undergone three annual examinations and five on the completion of his studies, besides preparing a satisfactory thesis. The schools for educating physicians and surgeons for the army and navy are under the direct management of the government. In Austria a certificate of the gymnasium is essential for admission to the medical schools; and a four years' course of study, confined almost exclusively to strictly professional branches, is requisite for admission to the final examinations which all candidates for the doctorate must pass. The course of study in the *medizinisch-chirurgische Facultät* of the royal university in Vienna, the greatest school of medicine in Austria, and in some respects the greatest in Europe, comprises 10 semi-annual courses, in each of which nearly 100 courses of lectures and practical exercises, comprising not less than 9,000 lessons of one hour each in every branch of medicine and nearly every disease within the range of medical practice, are given by 35 full professors, 19 assistant professors, and 39 *Privatdocenten*. The collections, museums, libraries, laboratories, botanical gardens, &c., constitute an array of material aids no less remarkable; while the general hospital, with its numerous divisions for all the important classes of disease, its thousands of beds, and superior facilities for a dozen or more distinct clinics on a large scale, surpasses all others in the world. The Prussian system of medical education is similar to that of Austria. In Great Britain admission to the medical schools is preceded by a thorough examination. The course of instruction is four years, two of which must have been spent in attending the medical and surgical practice of a general hospital having not less than 80 patients.—In the Italian universities a student is required to study law for five years in order to obtain the degree of doctor, and as a condition of admission he must possess the *certificato di licenza* (equivalent to an American A. B.), and pass an oral and written examination in Italian and Latin literature, ancient and modern history, and

moral philosophy. There are 21 faculties of *giurisprudenza*, with an average of 15 full professors, and in some cases honorary and extraordinary professors. There are also special courses in many of the faculties. At the conclusion of the first three years of study the degree of bachelor in law is conferred; at the end of the fourth year, the degree of licentiate; and at the end of the fifth, the diploma of doctor. In France there are 11 faculties of law, with 98 chairs. As in Italy, legal instruction is under control of the state, and the degrees and the general regulations governing admission are the same in both countries. No person in France is admitted to the courses prescribed for any degree unless a graduate in the arts. No one can practise as a barrister (*avocat*) without the degree of licentiate of law, or as a solicitor (*avoué*) without the *certificat de capacité en droit*. To obtain the degree of bachelor, which entitles the holder merely to practise as a solicitor, the candidate must complete the courses of the first two years and undergo examinations in the Institutes of Justinian and the Code Napoléon, the penal code, and the codes of civil procedure and of criminal instruction. The degree of licentiate is conferred only upon those who have received the degree of bachelor, have completed the third year's course of study in a faculty of law, and have passed examinations in the Code Napoléon and the codes of commerce and of administrative law, besides defending a thesis on questions of Roman and French law. To obtain the degree of doctor in law it is necessary to be a licentiate, to complete the four years' course of study, and to pass two examinations on Roman, French, and international law. For those who design to practise in a subordinate capacity, as mere solicitors, notaries public, &c., a *certificat de capacité en droit* is granted at the end of one year's study, embracing the first and second years' courses in the Code Napoléon and the codes of civil and criminal procedure. In the German empire law is taught in the universities, which have 30 faculties of law and about 300 professors. The degree of doctor is the only one conferred; the term of study is four years. The *Maturitätszeugniss* (corresponding to the American A. B.) granted by the gymnasia is requisite for admission. In the Scandinavian states the law schools are not numerous or provided with large corps of instructors. The gradation of studies and the degrees conferred resemble those of the French and Italian, rather than the German schools. Instruction is given by lectures, and examinations are frequent. The Anglo-Saxon schools of law, both in Great Britain and the United States, are regarded as vastly inferior to those of the continent. There are law departments in most of the British universities, which confer degrees only upon those who have a general knowledge of language, literature, and philosophy. In the United States law schools

are generally departments of colleges or universities. The professors number from one to five, and are often judges of the court or practising lawyers. The course of study is usually two years, on the completion of which the degree of bachelor (L. B.) is conferred almost as a matter of course, the final examination in many cases being merely nominal, or not required at all. Usually no educational or professional requirements for admission exist. In some instances this degree entitles the holder to practise in all the courts of the state; and even without the diploma of any law school, a person may be admitted to the bar upon examination, which is frequently very limited, in certain legal studies.—In Europe the system of ecclesiastical education comprises the two general divisions Protestant and Catholic, while in the United States there are almost as many kinds of theological schools as there are sects. The continental faculties of theology represent the one or the other of those two branches of the Christian church. In Italy, Austria, Bavaria, Belgium, Spain, and Portugal, they are Catholic; in the North German states, in Switzerland, the Netherlands, and Scandinavia, they are Protestant; while in France they are divided. In the United States, where there is no connection between church and state, each denomination guards its own theological interests by the establishment of such schools as may be required. Accordingly the 108 theological schools, with 435 professors and 3,351 students in 1872, were distributed among 19 sects. The multiplication of sectarian theological schools is also a feature of ecclesiastical education in Great Britain, but not so extended as in the United States. This department of education in France is provided for by 7 faculties with 42 professors; Italy, 8 faculties and 64 professors; Prussia, 12 faculties and 112 professors; Austria, 4 faculties and 38 professors; the Netherlands, 3 faculties and 14 professors; Denmark and Norway, each 1 faculty and 5 professors; Sweden, 2 faculties and 8 professors; and Great Britain, 8 faculties and 34 professors. In regard to the subjects taught and the qualifications for admission, there seems to be a nearer accordance among the different nations than in either medicine or law. In Europe the degree of A. B. or the certificate of maturity from the gymnasium is necessary to admission; in the United States the qualifications for admission in some cases are nearly the same, though in most of the theological seminaries little more than a common school education is really required. In France five professorships are regarded as essential (there are sometimes seven), and the term of study is three years; the Italian schools have eight full professors and a course of five years. In Germany the term of study is shorter, being four years in Austria and three in Prussia and most of the other states. The number of full professors is often 10 or 12, besides numerous extraordinary pro-

fessors and *Privatdozenten* who deliver courses of lectures. In Great Britain and the United States the course of study averages three years, and the number of professors is generally about four. The degrees conferred in European countries are those of bachelor, licentiate, and doctor in theology. In Great Britain and the United States only the bachelor's degree (B. D.) is conferred, except that the degree of doctor (D. D. or S. T. D.) is conferred honorarily. Very few of the American seminaries confer any degree in course.—The educational system of Europe embraces special schools devoted to almost every branch of science, art, and industry, viz.: science and art, arts and trades, chemistry, agriculture, forestry, veterinary surgery, mines, engineering, architecture, commerce and navigation, science and art of war, painting, sculpture, drawing, music, &c. In each of these departments special schools are organized with regular courses of study and well defined requisites as to admission and graduation. The extent and variety of schools devoted to special education in Germany are shown by the statement that in 1873 there were in the German empire 140 schools of agriculture, horticulture, &c., 34 of commerce, 27 of navigation, 18 of mining, 17 of forestry, 9 of veterinary surgery, 5 of surgery, 31 of architecture, 17 of music, 6 normal schools of gymnastics, 35 military schools, and 114 technical schools. In the United States many of these schools either do not exist at all, or have a very imperfect organization. In Great Britain and some continental countries schools are maintained for instruction and practical training in some branch of art, trade, or manufacture. The schools of chemistry usually have a two years' course and from six to twelve professors. In the United States there is no distinctive school of this class, but extended courses of instruction in chemistry are given in numerous schools connected with colleges and universities. Schools specially designed to give instruction in the applications of science to agriculture were founded in Prussia, Switzerland, and Austria as early as 1799, and they have since become general throughout Europe. The royal agricultural school of Hungary at Altenburg has nine professors and a two years' course. The applicant for admission must have completed the course of study embraced in the first seven classes of a gymnasium or the first five of a realschule.—The Russian agricultural schools rank among the best in Europe. The Petrovskoi agricultural and forestry academy near Moscow, established in 1865, has a faculty of agriculture and one of forestry, with 18 professors, and a farm of 1,200 acres. The course of study occupies three years in each faculty, and embraces the following general departments: agriculture, zoötechny, veterinary science and art, rural constructions, civil engineering, sylviculture, agriculture and forest technology, and rural and political economy. The academy con-

fers the degrees of bachelor and master, which are obtained only on examination. As early as 1837 the importance of creating state colleges of agriculture in the United States was urged by prominent agriculturists; but no institution of this kind was established till 1857, when the state agricultural college of Michigan was opened with seven professors and a farm of 676 acres. Similar institutions were soon organized by other states, and in 1862 congress passed an act providing for the establishment of colleges of agriculture and the mechanic arts in all of the states and territories, endowing them with about 8,000,000 acres of the public lands. Nearly all of the states have taken steps to organize institutions pursuant to this act, and in several of the states the institutions are in successful operation.—Numerous schools of mines of a high order are maintained in France, Saxony, Prussia, Austria, Sweden, Russia, and other European countries. The course of instruction is from three to four years, although in the imperial school of mines in St. Petersburg, which has 36 professors, it extends through eight years. In the United States schools of mining are of recent origin, and are connected with other institutions, as for example that connected with the Massachusetts institute of technology, the Lawrence scientific school of Harvard university, the Sheffield scientific school of Yale college, the mining school of Columbia college in New York, &c. The term of study varies from two to three and four years, on the completion of which the degree of mining engineer is conferred.—Schools of commerce of a high grade are maintained in most European countries, both separate and in connection with other institutions. Owing to the high character of this branch of education in France, commerce might be almost regarded as a profession. In the United States commercial training is afforded only by the business colleges established and maintained by private enterprise.—Perhaps the most extensive and magnificent institutions in Europe devoted to special education are the polytechnic schools, which are found in most of the continental countries. In the front rank of this class is the polytechnic school at Carlsruhe, Baden, which has upward of 50 instructors and more than 500 students. The main object of the institution is to educate engineers, machinists, architects, chemists, foresters, and agriculturists. It is divided into: 1, the mathematical school, with a course of two years; 2, the school for engineers, course two years and a half; 3, the school for machine builders, course three years; 4, the school of architecture, course four years; 5, the school of chemistry; 6, the school of forestry, with three different courses; 7, the school of agriculture, with a course of two and a half years. The standard of admission is very high, and the instruction is thorough. The system of polytechnic schools has been less developed in Great Britain than on

the continent, but ample instruction of this kind is afforded in the former country by numerous schools of the arts and academies of design, mechanics' institutes and museums with courses of lectures on various branches of applied science, and universities for the working classes, such as the Andersonian university in Glasgow, in which working men and others have the advantage of regular courses of lectures on the sciences. In the United States, the chief polytechnic schools, at least those distinctively so called, are the Massachusetts school of technology in Boston, the Rensselaer polytechnic institute in Troy, N. Y., the polytechnic college of Pennsylvania, in Philadelphia, and the Stevens institute of technology, in Hoboken, N. J. The first named institution, founded in 1862, comprises: 1, a school of industrial science; 2, a museum of arts; 3, a society of arts. The course of study is four years. Candidates for admission must have attained the age of 16 years and pass an examination in the branches ordinarily taught in a high school or academy. The objects of the institute are: 1, to provide a full course of scientific studies and practical exercises for students seeking to qualify themselves for the professions of the mechanical engineer, civil engineer, practical chemist, engineer of mines, and builder and architect; 2, to furnish a general education founded upon the mathematical, physical, and natural sciences, English and other modern languages, and mental and political science; 3, to provide courses of evening instruction in the main branches of knowledge above referred to for persons of either sex. Instruction of this kind is provided for in other institutions, and will constitute a feature in the colleges of agriculture and the mechanic arts endowed by the national grant.—Prominent among the excellent special schools of various kinds maintained in Europe, which are either not found in the United States or exist only in a very imperfect state, are the schools of forestry, which have contributed largely toward the preservation and better cultivation of forests. Among the best are those of Austria, which possesses vast public and private forests. The aim of these schools is to give a thorough theoretical and practical instruction in woodcraft, so as to prepare competent foresters and hunters. Instruction is classified into lower, middle, and superior; the course is from one to three years. The imperial academy of forestry at Mariabrunn is under the immediate administration of the minister of agriculture; it has one director and four professors, and a course of three years.—Until recently there have been in the United States either no opportunities for public instruction in veterinary science, or they have been exceedingly limited. The Massachusetts agricultural college and Cornell university have each a professor of veterinary science; and since 1857 there has been a veterinary college in New York which claims to

be the only regular institution of this kind in the country. The United States commissioner of education, John Eaton, estimating the value of all the horses in the United States at \$800,000,000, concludes "that the proportion of this amount annually lost for want of skillful medical treatment is not less than \$15,000,000." In Europe there are more than 25 well organized veterinary colleges, the best of which are found in Germany. The aim of the imperial school of veterinary surgery in Vienna, which may be taken as an example, is to educate veterinary surgeons for the army and the civil service, to advance the science of veterinary surgery, and to treat sick animals of every kind in its large and well appointed hospital. Instruction is theoretical and practical, the course lasting three years for students and two years for doctors of medicine and surgery who have taken a university degree. Besides annual examinations a rigorous examination is held at the end of the course, when certificates are given which entitle the graduate to become a veterinary surgeon in the army or in the civil service. A special two years' course of horse-shoeing, for private cavalry and artillery soldiers, is connected with the schools. When this is successfully completed, a certificate of "privileged horseshoer" is given. In some other veterinary schools the course of instruction is four years.—Schools of navigation are found in most of the maritime countries of Europe, the object of which is to train mariners and masters of merchant vessels. The school of navigation at Stettin, Prussia, has a director, two professors, and an assistant who teaches drawing. Lessons are given 32 hours a week for three years, the first being a course for pilots, while during the last two the art of navigating the high seas is taught.—Schools for nurses (midwives) are common in Europe, and in some countries no woman is allowed to practise as midwife unless she is provided with their certificate. Austria has eight of these schools, and instruction of the same kind is also given to women at the faculties of medicine in the universities and at the schools of surgery. The course of instruction occupies four, five, or six months. It is both theoretical and practical, and is given by a professor of obstetrics, aided by a midwife and a nurse. A thorough examination is held at the end of the course. In the Austrian schools for midwives more than 1,200 are instructed every year. The United States are very deficient in means for such education, though a few of the medical colleges have courses of lectures for nurses, and the number of female medical schools is increasing.—Special schools of architecture, although of comparatively recent origin, now form a part of the educational system of various continental countries. In the royal architectural academy of Berlin instruction is given by more than 20 professors besides numerous assistants, and extends through from five to seven years. A certificate of builder is given after a two years'

selected course and one year of practice; and that of architect after three years' study and two of practice.—Among the most valuable works on the subject of education are: Schwarz, *Erziehungslehre* (Leipsic, 1829); Cramer, *Geschichte der Erziehung und des Unterrichts in welthistorischer Entwicklung* (Leipsic, 1832-'8); Cousin, "Report on Public Instruction in Prussia" (New York, 1835); Foster, "Educational Reform" (London, 1837); Bache, "Report on Education in Europe" (Philadelphia, 1839); Von Raumer, *Geschichte der Pädagogik seit dem Wiederaufblühen classischer Studien* (Stuttgart, 1843-'52); Fritz, *Esquisse d'un système complet d'instruction et d'éducation* (Strasburg, 1841-'3); E. D. Mansfield, "American Education" (New York, 1851); Henry Barnard, "National Education in Europe" (New York, 1854); Edison, "National Education" (London, 1855); Horace Mann, "Lectures on Education" (Boston, 1855); Théry, *Histoire d'éducation en France* (Paris, 1858); Wiese, *Das höhere Schulwesen in Preussen* (Berlin, 1864); Lowe, "Primary and Classical Education" (Edinburgh, 1867); Blake, "American Schools and Colleges" (London, 1867); Matthew Arnold, "Schools and Universities on the Continent" (London, 1868); Randall, "First Principles of Popular Education and Public Instruction" (New York, 1868); Staunton, "The Great Schools of England" (London, 1869); Arnott, "National Education" (London, 1869); Roberts, "National Education" (London, 1869); "Report on Education," by John W. Hoyt, United States commissioner on education to the Paris exposition of 1867 (Washington, 1870); J. W. Hoyt, "University Progress" (New York, 1870); *Encyclopädie des Erziehungs- und Unterrichtswezens*, edited by Dr. K. A. Schmid of Stuttgart (81st part, 1871); Barnard, "National Education," German States (New York, 1871); Randall, "History of the Common School System of the State of New York" (New York, 1871); Hazen, "The School and the Army in Germany and France" (New York, 1872); "Report of Committee of Council on Education for 1871-'2," Great Britain (London, 1872); Carl Rosenkranz, *Die Pädagogik als System* (Berlin, 1847; English translation by Anna C. Brackett, St. Louis, 1873); Dr. G. A. Riecke, *Erziehungslehre* (3d ed., Stuttgart, 1873); Herbert Spencer, "Education, Intellectual, Moral, and Physical" (New York, 1873); "Education in Japan, a Series of Letters addressed by prominent Americans to Arinori Mori" (New York, 1873); Northrop, "Education Abroad" (New York, 1873); Rigg, "National Education in its Social Conditions and Aspects, and Public Elementary School Education, English and Foreign" (London, 1873). See also Lüben's *Pädagogischer Jahresbericht*, published annually at Leipsic; Wolfram's *Allgemeine Chronik des Volksschulwesens*, published annually at Hamburg; annual reports of the United States bureau of education, beginning with 1870, also numer-

ous circulars of information published by that bureau; and the annual reports of the superintendents and boards of education for the various states and cities of the United States.

**EDWARD I.**, surnamed the Elder, king of the West Saxons, son and successor, in 901, of Alfred the Great, died in 925. His claim to the throne, though recognized by the witenagemote, was disputed by his cousin Ethelwald, who gained the support of the Northumbrian and East Anglian Danes. The rebels marched through the counties of Gloucester, Oxford, and Wilts, and Edward, unable directly to oppose them, retaliated their ravages in the country of the East Angles. He thought proper to withdraw his army, loaded with booty, before the approach of the rebels; but the Kentish men, greedy of more spoil, stayed behind in defiance of orders. They were assaulted by the East Angles, and resisted so valiantly that, though at last obliged to retreat, it was not till after they had slain a great number of the enemy, and had terminated the rebellion by causing the death of Ethelwald himself. The reign of Edward was occupied with subduing the turbulent Danes, who abounded and were constantly reinforced in the provinces of East Anglia and Northumbria. In this he was assisted by his sister Ethelfleda, who governed Mercia. He protected his territories by fortresses which gradually became centres of trade and population. He gained two victories at Tempsford and Maldon, and subjected all the tribes from Northumbria to the channel. His sons Athelstan, Edmund, and Edred successively occupied the throne.

**EDWARD II.**, surnamed the Martyr, king of the Anglo-Saxons, son and successor of Edgar, born about 962, ascended the throne in 975, and was murdered in 978. His stepmother Elfrida raised a faction in favor of her own son Ethelred, who was but seven years of age. Ecclesiastical parties took opposite sides, the married clergy who had been ejected in the preceding reign regarding Elfrida as their patroness and supporting the pretensions of Ethelred, and the monastic followers of St. Dunstan maintaining the claim of Edward. A civil war had already begun, when at a general meeting of the witenagemote Edward, after much opposition, was formally accepted as king. The strife among the clergy still divided the kingdom, and the party opposed to St. Dunstan plotted the murder of the young monarch. He was stabbed in the back at Corfe castle, the residence of his stepmother, as he was drinking a cup of mead on horseback, and sinking from his seat was dragged away by his horse. Ethelred II. succeeded him.

**EDWARD III.**, surnamed the Confessor, king of the Anglo-Saxons, son of Ethelred II. and successor to Hardicanute, born at Islip, Oxfordshire, about 1004, ascended the throne in 1042, and died Jan. 5, 1066. His mother was a Norman princess, Emma, and during the Danish

domination which succeeded the death of Edmund Ironside he dwelt in exile in Normandy. On the death of Canute in 1035 he crossed the channel with 40 ships, and landed at Southampton. He found himself opposed by his mother, who had become a second time queen of England by marriage with the Danish monarch, and was now regent of the kingdom. Menaced by a constantly increasing force, he hastily retreated. With his brother Alfred he received a perfidious invitation from King Harold to cross the sea in 1037. Alfred was murdered at Guildford, but Edward escaped into Flanders. After the accession of his half brother Hardicanute, Edward was received with honor into England, and was at court when the king suddenly died in 1042. The Danish heir Sweyn was then absent from the kingdom; the rightful heirs of the Saxon line, the sons of Edmund Ironside, were in exile in Hungary; the Anglo-Saxons were determined to throw off the Danish yoke; the Danes were divided and dispirited; Edward was the nearest to the throne of any one present, and after a short period of hesitation and commotion he was recognized as king in a general council at Gillingham. During his reign the mutual aversion of the two fierce Teutonic peoples, whose struggles had vexed the country during six generations, began to subside, intermarriages and a blending of language and customs having nearly effaced the distinction between them, and the Normans began to exercise a potent influence in the country. The first royal act of Edward was to dispossess his mother of her immense treasures, and to confine her for life in a monastery at Winchester. The government was in the hands of three powerful noblemen: Earl Godwin, who ruled all the southern provinces; Earl Leofric, who governed Leicester and the northern counties of Mercia; and Earl Siward, whose sway extended from the Humber to the confines of Scotland. Edward married Earl Godwin's daughter Editha, a lady praised by the chroniclers for her learning, piety, and benevolence; but his motive was merely political, and the alliance proved a source of enmity between the king and his father-in-law. Edward was partial both to Norman manners and people; many foreign churchmen and dignitaries had followed him to England, where they had acquired influence in the government. A popular jealousy was already felt against them, when in 1051 Eustace, count of Boulogne, with his train, visiting England, quarrelled with the burghers of Dover, and in the tumult several persons were slain. Edward gave orders to Godwin, in whose government Dover lay, to chastise the insolence of the men of that city. The earl refused to obey; and three armies under the command of Godwin and his two sons immediately marched against the king in Gloucestershire. Edward summoned to his aid Leofric and Siward, and was quickly in a condition to intimidate his opponents, when it was agreed to refer the dispute

to the witenagemote. But Godwin fled with his wife and sons to Flanders; their estates were then confiscated, and Queen Editha was confined in a monastery. Tranquillity was hardly restored when William, duke of Normandy, the future conqueror, reached the coast of England to assist his royal kinsman. He was received honorably, visited several of the royal villas, and was dismissed with magnificent presents. Godwin, having gradually collected a fleet, suddenly appeared in 1052 on the southern coast of England, swept away the ships from the harbors, entered the Thames, menaced London, and extorted from the king the restoration of himself and his son Harold to their earldoms and the banishment of the foreigners. Godwin did not long survive this triumph, and left his possessions to his son Harold. At this period occurred the events which form the groundwork of Shakespeare's tragedy of "Macbeth." In 1039 Macbeth, a turbulent nobleman, murdered Duncan, king of Scotland, chased Malcolm, his son and heir, into England, and usurped the crown. The exiled prince received from Edward permission to vindicate his rights with an English army, and at length in 1054 was successfully supported by Macduff, thane of Fife, and Siward, earl of Northumberland. But the support which Edward gave to Malcolm resulted in adding largely to the power of his own most ambitious and dangerous subject. To oppose Harold's progress, the king invested Algar, the son of Leofric, with the government of East Anglia, which, after a struggle, he succeeded in holding. At Algar's death in 1058 Harold was left without a rival, the most powerful subject in England. Edward the Outlaw, the Saxon heir to the throne, after a life of exile, died within a few days of his arrival in England, and there now stood between Harold and the crown only the returned exile's young and feeble son Edgar. The infirm old king turned his eyes toward his kinsman, William of Normandy, as a person whose capacity and power would render him the most formidable rival to Harold; but he was deterred by the latter, on his return from Normandy, as Hume says, from abdicating in William's favor, and Harold was crowned on the day of Edward's death. The laws and customs of "good King Edward" were long remembered with popular affection. He was highly esteemed for his sanctity, was the first English prince that touched for the king's evil, and was canonized and styled "the Confessor" about a century after his decease. The most commendable feature of his government was his attention to the administration of justice, and to collecting the laws of the realm.

**EDWARD I.** (of the Norman line), king of England, surnamed Longshanks, from the excessive length of his legs, son of Henry III. and of Eleanor of Provence, born in Westminster, June 16, 1239, crowned Aug. 19, 1274, died July 7, 1307. Being invested with the duchy

of Guienne, his right to that province was disputed by Alfonso X. of Castile, who renounced his claim in consequence of Edward's marrying his sister. In 1254 he received the lordship of Ireland and of the provinces which had been seized in the reign of John Lackland by the king of France. He supported the throne against the revolted barons, and with his father and his uncle Richard, king of the Romans, was made prisoner at the battle of Lewes, May 13, 1264. He recovered his liberty in 1265, defeated and slew Simon de Montfort, earl of Leicester, at Evesham, and in 1267 conquered the last of the insurgents in the isle of Ely. Shortly after he joined the crusaders, and served two years in the East. Nearly two years after his father's death he was crowned without opposition at Westminster, and began to signalize his ability both as a warrior and legislator. His arms were first directed against Llewellyn, prince of the Welsh, whom he reduced, but who rebelled again, and was slain in single combat by an English knight immediately after the army of Edward had reappeared in that country. He established corporate bodies of merchants in the principal towns of Wales, and introduced the jurisprudence of the English courts. Edward, as the chroniclers have it, had promised to appoint as prince of Wales a person born in the principality, and who could not speak English. His queen Eleanor, being delivered of a son in the castle of Carnarvon, the English king maintained that his son fulfilled the conditions, and declared him prince of Wales, a title which has ever since been borne by the eldest son of the sovereign. In 1289 he resolved upon the subjugation of Scotland, to whose crown there were at this time 13 claimants. Being invited to the office of arbitrator, he took possession of many of the Scotch fortresses, and then conferred the crown upon John Balliol, who soon renounced his allegiance. Edward marched again across the Tweed, gained a great victory at Dunbar in 1296, sent Balliol into exile, bore away the Scotch sceptre and crown, and left the highest offices in the hands of Englishmen, under the earl of Surrey, who received the title of guardian of the kingdom. The Scots rallied in 1297 under the chieftain William Wallace, and drove the English out of their kingdom, totally defeating them in the battle of Stirling, Sept. 10. Edward hastily finished the war which he had meanwhile undertaken in France, advanced again to the Forth, and defeated the insurgents with the loss of from 20,000 to 40,000 men near the forest of Falkirk, July 22, 1298. Wallace himself escaped. The rebellion again broke out in 1303, and again Edward overran the kingdom, its temporary subjugation being completed by the surrender of the strong castle of Stirling. Wallace was soon after surprised and captured, and was hanged in Smithfield (1305). In 1306 the war was again kindled by Robert Bruce, who was elected king, and,

though at first unsuccessful, at length gained a decisive victory over the earl of Pembroke. Edward marched again to the north, but was surprised by death on the frontier at Burgh-upon-Sands. The most enduring results of the reign of Edward were the reforms which he introduced in the administration of government, of justice, and of the finances, which had gained for him the title of the "English Justinian." He ameliorated the laws, confirmed and finally established the two great charters, gave to the parliament the form it has since retained, and is said to have first instituted justices of the peace. The Jews during his reign were cruelly despoiled, and in 1290 ordered under penalty of death to quit England for ever before a certain day.—See "History of the Life and Times of Edward I.," by William Longman (2 vols., London, 1869).

**EDWARD II.**, king of England, son and successor of the preceding, born in Carnarvon, April 25, 1284, ascended the throne in 1307, and was murdered Sept. 21, 1327. From his childhood he had lived in close intimacy with Piers de Gaveston, the son of a gentleman of Guienne, who was at length banished from the kingdom as a corrupter of the prince. Edward I. on his deathbed forbade his son under pain of his paternal malediction to allow the vicious favorite to return; yet the first act of the new king was to recall Gaveston, whom he created earl of Cornwall and married to his own niece, and to the scandal of the whole kingdom appointed him regent while himself went to France to marry the princess Isabella. A formidable league under the earl of Lancaster drove Gaveston into exile; but he was appointed lieutenant of Ireland by his royal friend. He returned soon after, when an army raised by confederate powerful barons and commanded by the earl of Lancaster pursued him to the north; he was besieged at Scarborough, captured, and put to death at Warwick, June 19, 1312. Edward then turned his attention to the revolted Scots. At the head of an immense army he crossed the frontier, but after losing the battle of Bannockburn (1314) fled from the kingdom with a body of Scottish cavalry at his heels. In 1321 he was again defeated at Blackmoor, and pursued to the walls of York. The public discontent was increased by the honors which the king bestowed upon Hugh le Despenser, a new favorite, and an armed insurrection of the barons under the earls of Lancaster and Hereford caused the Despensers to be banished; but on their return Lancaster was seized and put to death. In 1323 Edward negotiated a truce for 13 years with Scotland. The triumph of the Despensers was complete, but the partiality of the king for his favorites alienated not only his subjects but his queen. To arrange some differences between her husband and her brother she went to France, where she found a great number of English fugitives, the friends of Lancaster,



the most considerable and potent of whom was the young Roger Mortimer. A domestic rebellion supported by a foreign invasion was projected, and in September, 1326, the queen with a foreign force of 3,000 men, led by Mortimer and John of Hainaut, landed on the coast of Suffolk. The most powerful nobles and prelates hastened to meet her, and Edward, having in vain appealed to the citizens for support, retreated to the marches of Wales. The queen pursued him, and he was captured at Neath abbey, Glamorganshire, and sent to the castle of Kenilworth. The favorite Despenser was taken at the same time and hanged. The parliament being assembled, by the influence of Isabella and Mortimer, it was resolved, in January, 1327, that the reign of Edward of Carnarvon had ceased. While imprisoned in Berkeley castle under the charge of ruffians employed by Mortimer, Edward II. was found dead in his bed in the morning after shrieks had been heard from his apartment, and his distorted features betrayed the agony in which he had expired. It is said that his bowels were burned out with a hot iron.

**EDWARD III.**, eldest son of Edward II. and Isabella of France, born at Windsor, Nov. 13, 1312, proclaimed king of England Jan. 25, 1327, died at Shene (now Richmond), June 21, 1377. At the age of 12 he went with a splendid retinue to France to do homage to Charles IV. for the possession of Guienne and Ponthieu, which had been resigned to him by his father. He remained with his mother at the French court, was contracted in marriage by her to Philippa, daughter of the count of Hainaut, whom he married Jan. 24, 1328, and was declared king after the captivity of his father. A council of regency, consisting of four bishops and ten noblemen, most of whom, being of Isabella's party, gave up to her and Mortimer (now created earl of March) the ascendancy in the government, had but just been appointed, when Robert Bruce, in violation of the truce, sent an army of 24,000 men under Randolph and Douglas, which ravaged the county of Cumberland. Young Edward marched to the north with more than 40,000 men, made a vain pursuit of the Scots, came up with them twice when they were in inaccessible positions, is recorded to have wept when he found himself outgeneralled by an inferior enemy, and concluded an inglorious campaign by a treaty in which the entire independence of Scotland was recognized. The odium of this settlement was thrown upon Isabella and Mortimer, who increased their unpopularity by intrigues against the earl of Kent, whom they caused to be executed for high treason in 1330. In the same year Edward asserted his own authority against his mother and her paramour. Mortimer was executed for high treason at Smithfield, and Isabella was confined for the rest of her life in the manor of Risings. He immediately renewed his father's project of conquering Scot-

land, and secretly encouraged the claim of Edward Balliol to the crown of that country, who was willing to hold it as a fief of the English monarch. Balliol won the crown and lost it within three months, and the incursions of the Scots gave to Edward a pretext for renewing the war. He laid siege to Berwick, and on July 19, 1333, defeated on Halidon hill with great loss the army of the regent Douglas. The town and castle were immediately surrendered, and Balliol, being again seated on the throne of Scotland, ceded a large territory to England, a measure which was followed by his flight to that country within four months. Three times in three years Edward invaded and devastated Scotland in support of Balliol, and then laid claim to the crown of France against Philip of Valois. The ground of this pretension was, that although females were excluded from the French throne, their male descendants were not; and that as the son of Isabella, the daughter of Charles IV., his claim was better than that of Philip, who was descended from a younger brother of Charles IV. Edward made alliance with several continental princes and rulers, the chief of whom were Louis the Bavarian, emperor of Germany, the dukes of Brabant and Gueldres, and James van Artevelde of Ghent. He formally published his claim in 1337, and in the following year sailed with a numerous fleet to Antwerp, designing to begin the campaign with the siege of Cambrai; but perceiving the difficulty of the enterprise, he advanced into France with about 50,000 men, was almost confronted with an army of nearly double that force under Philip, yet no engagement ensued, and he returned to Brussels and disbanded his army without having derived any advantage from his immense expenditures. He returned to England in 1340, obtained an unprecedented grant from parliament, defeated a French fleet off Sluis, returned to the continent, and at the head of nearly 200,000 men, including his Flemish allies, undertook at the same time the sieges of Tournay and St. Omer, both of which were unsuccessful; and he quickly concluded an armistice for nine months, and soon after another for three years and eight months. Another English campaign in France was begun in 1346 under the earl of Derby, and prosecuted with uninterrupted success. Edward also landed with a numerous force on the coast of Normandy, advanced to Rouen, sent his light troops to insult the faubourgs of Paris, and on Aug. 26 gained over Philip the decisive battle of Crécy. The siege of Calais followed, and while the chivalry of England lay before the walls of that city, the Scots suddenly crossed the frontier, but were defeated near Durham by a miscellaneous and rapidly collected army, and their king David captured. Calais surrendered after an obstinate defence, and a truce followed which lasted till 1355. Meantime Edward invaded and widely desolated Scotland, causing a havoc long remem-

bered. The war was renewed in France under the Black Prince, who gained on Sept. 19, 1356, the memorable victory of Poitiers, in which he took King John of France prisoner. The Scottish king was ransomed for £100,000 in 1357, and in 1360 the "great peace" was concluded at Bretigny, by which Edward renounced his pretensions to the crown of France and restored his conquests, retaining only the full sovereignty of Poitou, Guienne, and the county of Ponthieu. Though the misfortunes of the latter years of his reign contrasted strongly with the glories of its commencement, and though his victories left few lasting acquisitions, yet they gave to England a lustre and renown which were long her strength and safety. In his reign the elegant arts began to be cultivated, the castle of Windsor was rebuilt, and English poetry and prose may be said to have been begun. He was succeeded by his grandson Richard II.

**EDWARD IV.**, king of England, born in Rouen, April 29, 1441, died April 9, 1483. The lot of the feeble Henry VI. fell in an age of violence, to which he brought only meekness of spirit. His own insignificance, the dishonor of the English arms, and the passionate tyranny of his indomitable queen, Margaret of Anjou, revived the long forgotten pretensions of the house of York. The great Lancastrian chiefs, Cardinal Beaufort and the dukes of Bedford and Gloucester, who supported the throne during the minority of Henry, were dead, when Richard, duke of York, the father of Edward IV., cautiously and gradually advanced his claim to the throne, gained the support of the powerful earls of Warwick and Salisbury, took arms against Somerset, the last great nobleman of the Lancastrian branch, and began by a victory at St. Albans, in 1455, the wars between the red rose of Lancaster and the white rose of York. The claims of both these Plantagenet lines were derived from Edward III. From the first two sons of that sovereign no issue survived; the three Lancastrian kings who had occupied the throne for more than half a century were descended from the fourth son; the dukes of York were descended from the fifth son, but had also by intermarriage become heirs to the rights of the third son. The question was rendered more complicated by the irregular accession of the first Lancaster while Edmund Mortimer, heir of the third son, was alive, and by decrees of parliament. Richard, duke of York, after various successes and reverses in maintaining his claim, was defeated and slain by Queen Margaret, at Wakefield, in 1460; but young Edward immediately put himself at the head of an army of Welsh borderers and mountaineers, and defeated a formidable force under the earls of Pembroke and Ormond, near Hereford. He then marched southward, supported by the earl of Warwick, who suffered a defeat at Barnet, by which Henry was again restored to his friends. Edward marched di-

rectly to London, which he entered without opposition, and where his youth, boldness, and beauty gained him the public favor. He was proclaimed king by parliament, March 4, 1461, and thus there were two kings and two royal armies in the land. Both parties made formidable preparations for battle, and at Towton, near York, 100,000 Englishmen were drawn up, in not very unequal division, in hostile array. Proclamation had been made that no quarter should be given, and the battle (March 29, 1461) was probably the bloodiest ever fought in England. It lasted more than a day, and ended, after the slaughter of over 30,000 persons, in the total rout of the Lancastrians; and thus the crown was firmly placed on the brow of Edward IV. Margaret sailed to France, seeking the alliance of the French king; and in 1464 she appeared again in Scotland, at the head of only 500 French troops, with whom, and a band of Scottish borderers, she gave battle to the English general, Lord Montacute, near Hexham. The Lancastrians were again completely routed; the king and many of the chiefs were captured, and Margaret again made her escape into France. Edward, anticipating the maxim of Machiavelli, made a terrible slaughter of his enemies in the first moment of victory, and in his subsequent administration ruled with clemency. After this second retreat of Margaret, he devoted himself for a time to pleasure. He had privately married Elizabeth, widow of Sir John Gray and daughter of Richard Woodville, Baron Rivers, whom he had met at her father's house while hunting in the forest of Grafton. In September she was publicly acknowledged queen, and her father was made an earl. This union displeased the powerful and haughty earl of Warwick, who had been authorized to negotiate a marriage between the king and the princess Bonne of Savoy, and had succeeded in doing so. Alying himself with Edward's brother, the duke of Clarence, he revolted in 1469. The effect of his combination with the discontented nobility and gentry was quickly seen in seditions fomented in every part of the country. In Yorkshire, Robin of Redesdale, a hero among the troopers of the frontier, took the field with 60,000 men. Edward marched against them. Warwick, absent in France, had gained the favor of Louis XI., and become reconciled with his old enemy Margaret. He landed at Dartmouth with a small body of troops, where his popularity swelled his army in a few days to more than 60,000 men. He advanced to the north, and his approach shook the fidelity of the royal troops. Edward fled in 1470 to Holland, and his imprisoned rival was led forth from the tower to hear the streets of London resounding once more with the name of King Henry. A parliament was summoned in the name of the restored king, by which Edward was pronounced a usurper, his adherents were attainted, and all acts passed by his authority repealed. Secretly assisted by the duke of

Burgundy, Edward collected a body of Flemings and Dutchmen in a few months, with whom he landed at Ravenspur. He advanced into the interior, pretending at first that he came only to recover his patrimony as duke of York, and making his followers cry "Long live King Henry," till he received reinforcements which put him in a condition to face the enemy. The armies met at Barnet on April 14, 1471, and the Lancastrians were defeated and Warwick himself was slain. Edward again became master of London, and of the person of Henry, who was remanded to the tower. Meanwhile Margaret, with her son Edward, 18 years of age, landed at Weymouth at the head of a body of French troops on the very day of the battle of Barnet. With an army commanded by the duke of Somerset she made a stand at Tewkesbury, May 4, 1471. Her army was defeated, her son Prince Edward slain, and she herself taken prisoner and held in captivity five years, when she was ransomed by the king of France. Her husband perished in the tower a few weeks after the battle. Edward formed an alliance in 1474 with the duke of Burgundy, by which France was to be divided into two states, one of which, comprehending the northern and eastern provinces, should belong to Burgundy, and the other should be possessed by England. He passed over to Calais with a force of archers and men-at-arms, only to be disappointed by the duke of Burgundy, who sent his apology instead of an army, and to make an advantageous treaty with Louis without a battle. By this treaty pensions of considerable amounts were bestowed by Louis not only upon the English king, but upon all the considerable persons of the English court. Edward then became involved in a bitter strife with his brother Clarence. The interference of Edward prevented the marriage of Clarence with the wealthy heiress of Burgundy; soon afterward two of the friends of Clarence were put to death upon a frivolous pretence, joined with an accusation of sorcery; and when he maintained their innocence, he was himself privately put to death in February, 1478, on a charge of treason for arraigning public justice. During the latter part of his life Edward was sunk in indolence and pleasure. He left five daughters, of whom Elizabeth was afterward married to Henry VII.; and two sons, the ill-fated princes Edward and Richard.

**EDWARD V.**, king of England, of the York branch of the Plantagenets, son and successor of the preceding, born Nov. 4, 1470, in the sanctuary of Westminster abbey, whither his mother had fled from the army of the Lancastrian Queen Margaret and of Warwick, died doubtless by murder in the tower of London in 1483. At the time of his father's death, April 9, 1483, young Edward was residing on the borders of Wales, in the care of Earl Rivers, brother of the queen. In company with Rivers he immediately set out for London, while the duke of Gloucester, brother

of the late king, and now regent during the minority, started south from York, attended by a splendid retinue. The two processions met at Stony Stratford, when Gloucester approached the young prince with the greatest demonstrations of respect, but soon after charged Rivers and the queen's son, Sir Richard Grey, with having aimed to estrange from him the affection of his nephew, arrested and imprisoned them in the castle of Pomfret, and endeavored unsuccessfully to satisfy Edward with regard to the violence thus exercised upon his kindred. The king was from this time a captive. The queen mother hastily took refuge with her second son, the duke of York, and her five daughters, in the sanctuary at Westminster. Gloucester postponed the coronation of the young king, confined him for security in the tower, and was formally invested with the office of protector. His next step was to withdraw the duke of York from his retreat with his mother at Westminster; but he had still to fear opposition on the part of those noblemen, such as Lords Hastings and Stanley, who were friends of the late king, and unswerving in their fidelity to his children. Their destruction or imprisonment without form of trial, or even specification of offence, swiftly followed. Earl Rivers also and his friends were put to death without any semblance of judicial forms. The amours of the late king now suggested to Gloucester a means of vilifying the queen dowager and her descendants. He did not hesitate to malign his own mother, affirming that the resemblance of Edward IV. and of the duke of Clarence to notorious gallants was a sufficient proof of their spurious birth, and that the duke of Gloucester alone, of all his sons, appeared by his features and countenance to be the true offspring of the duke of York. He openly denied the title of Edward V., who meanwhile, with his brother, languished in prison. The precise time and the details of the death of these princes are unknown. A conspiracy had been set on foot for their liberation during the first year of the usurper's reign, when it was announced that they were no longer alive. Sir Thomas More's account, which was collected from the confession of the murderers in the next reign, is as follows: that Richard had in vain tampered with the governor of the tower, Brackenbury, to put them to death, but found a ready instrument for the execution of his purpose in Tyrrel, his master of horse; that Tyrrel was despatched with a commission to receive the keys of the tower for one night, and during that night he watched without while one of his grooms, accompanied by a notorious assassin, entered the sleeping room of the princes, stifled them with feather beds and pillows, and buried their bodies at the foot of the staircase. The testimony of More is almost contemporaneous with the event itself, and is confirmed by the honors which were certainly conferred upon

the alleged murderers. In the reign of Charles II., when alterations were made in the tower, there was found at the foot of an old stairway a heap of decayed bones which were supposed to be those of two boys. They were removed by royal command to Westminster abbey, where an inscription, beginning *Ossa desideratorum diu et multum quesita*, was placed upon the monument.

**EDWARD VI.**, third king of England of the Tudor dynasty, born Oct. 12, 1537, ascended the throne in 1547, and died July 6, 1553. The son of Henry VIII. and Jane Seymour, he was little cared for by the three stepmothers whom he had in quick succession; but at the age of six years, being intrusted to the learned masters Anthony Cooke and John Cheke, he made progress in philosophy, divinity, Greek, and Latin. Henry VIII. appointed in his will a council of executors to exercise the royal authority during the minority of his son, who at their first meeting, fearing that the government would lose its dignity for want of some head to represent the royal majesty, bestowed upon Edward Seymour, now created duke of Somerset, or allowed him to assume, the titles of governor of his majesty, lord protector of all his realms, and lieutenant general of all his armies. Sir Thomas Seymour, the brother of Somerset, was created Baron Seymour of Sudley, and appointed lord high admiral. The government was almost entirely Protestant, and its first object was to complete the religious revolution and establish a church independent of the see of Rome. The statute of the six articles was repealed, prisoners under it were released, and exiles were recalled. Preaching, which had been rare in Catholic times, was enforced by visitors despatched throughout the kingdom, who were authorized to require that four sermons be preached every year in every church against the papacy. Images, which Luther had tolerated as aids to devotion, and of which Cranmer vindicated a moderate use, became objects of dislike, and were torn down in places where they had been honored by pilgrimages and offerings. The English Bible, with Erasmus's commentary on the gospels, was placed in every church for the use of the people. In the first parliament the statutes of Richard II. and Henry IV. against the Lollards were repealed, together with all the acts in matters of religion passed under Henry VIII., except those directed against the papal supremacy. The uniformity of public worship was established, and all ministers were enjoined to use only the "Book of Common Prayer." The English clergy were emancipated from compulsory celibacy, though it was recommended to them "to live separate from the bond of marriage, for their own estimation, and that they might attend solely to the ministration of the gospel." There were as yet no Protestant nonconformists, but all persons were commanded to attend public worship under pain of ecclesiastical censures,

of six months' imprisonment for the first offence, twelve for the second, and confinement for life for the third. Bonner, bishop of London, Gardiner, bishop of Winchester, and several others, were deprived of their sees because they could not keep pace with the reformatory movement. The first step toward religious liberty was a distinction, recognized practically though not by canon, between what were supposed to be the essential and the unessential parts of Christianity, and only offences against the former were liable to deadly persecution. Thus, no Roman Catholic suffered death for religion in this reign; but Joan Bocher, commonly called Joan of Kent, was burned for an unintelligible heresy, which denied something, though her words vainly struggled to explain what, concerning Christ. Van Parris, a Dutchman, was also burned for denying the divinity of the Saviour. Among civil occurrences in this reign, the first of importance, after the settlement of the government, was the expedition of Somerset into Scotland to compel the marriage of Mary, the young queen of Scots, to Edward, according to a previous treaty. A bloody encounter, begun between the Scottish and English cavalry at Falside, Sept. 9, 1547, was continued the next day between the entire armies at Pinkie, and ended in the victory of the English protector. But he was quickly called home by machinations against him, and Mary was sent to France. His brother and rival, Lord Seymour, was committed to the tower early in 1549, and a bill attainting him was brought into the house of lords. This bill, by the influence of Somerset, who was present in the house to encourage it, was passed unanimously within three days; and Seymour, without an opportunity to defend himself or to confront his accusers, was beheaded on Tower hill, March 20. During the next summer formidable insurrections broke out in various parts of the kingdom. The depreciation of the currency during the last reign had been followed by an advance in the price of commodities; at the same time the demand for labor had been lessened and wages reduced. The new owners of abbey lands had enclosed many of the fields which had formerly been allotted for the common use of the poor inhabitants, and their rapacity was contrasted with the indulgence of the monks, who had often been the most lenient of landlords. There were armies of insurgents in several counties, the largest and most violent being in Cornwall, where a tanner named Kett encamped near Norwich at the head of 20,000 men. He repulsed the marquis of Northampton, but was at length defeated and hanged with his principal associates. The protector had incurred odium by what was termed his feeble administration during this rebellion, and also by his lavish expenditures upon his magnificent palace of Somerset house. He had wavered and almost given sanction to the demands of the populace when they were in arms against the royal au-

thority; and had become from a simple knight with a slender fortune the possessor of more than 200 manors and parcels of land. The discontented lords, directed by Dudley, earl of Warwick, gradually withdrew from court and met in London with bodies of their retainers. The protector, as soon as he received intelligence of their movements, took the king with him to Windsor, and called by proclamation on all faithful subjects to join him at Hampton court in arms for the protection of the royal person against a conspiracy. Multitudes of the common people, but scarcely a gentleman, obeyed his summons, and his cause was rendered desperate when the council declared against him. The king was obliged to sanction the vote for his deposition, and he was brought to London and incarcerated in the tower, Oct. 14, 1549. Warwick dissembled for the moment his purpose concerning the prisoner, and was obliged by his position, though a secret Catholic, to favor the cause of the reformation, and, though a rancorous enemy of Somerset, soon to set that nobleman free, and to give his own son in marriage to Somerset's daughter. But when Warwick had received the office of lord high admiral, had been raised to the dignity of duke of Northumberland, had become the undisputed chief of the government, and had annihilated the power of Somerset, he was able to proceed further against that duke, who was again committed to the tower in 1551, was convicted of felony, and executed on Tower hill, Jan. 22, 1552. Warwick next persuaded Edward to make a new settlement excluding his sisters from the succession to the throne, and giving the nomination to Lady Jane Grey, who had been his playmate and companion in studies. Edward sank rapidly after this, and died in the 16th year of his age and the 7th of his reign. His accomplishments were such as to surprise the famous Italian physician Jerome Cardan, who visited him in his last sickness; and for his diary and other compositions he is included by Walpole in his list of royal authors. He was succeeded by his sister Mary, after Lady Jane Grey's nominal reign of a few days.—The literary remains of Edward VI., edited with historical notices and a biographical memoir, by John Gough Nichols, were printed in 1859, for the Roxburgh club (2 vols., London).

**EDWARD**, prince of Wales, surnamed the Black Prince, from the color of his armor, eldest son of Edward III. and Philippa of Hainaut, born at Woodstock, June 15, 1330, died June 8, 1376. In his 16th year he accompanied his father in his invasion of France, and he held the nominal command of the largest and most actively engaged division of the English forces in the battle of Crécy. Among the slain was John of Luxemburg, the blind king of Bohemia, whose crest of three ostrich feathers, with the motto *Ich dien* (I serve), was adopted by the prince of Wales, and has always been

borne by his successors. In 1356 he gained the victory of Poitiers, in which the French King John was taken prisoner. He returned to England in 1357, the king of France on a splendidly caparisoned charger forming the principal ornament of the cavalcade with which he entered London. In 1361 the king of England united all his dominions between the Loire and the Pyrenees into one principality, and bestowed it upon the Black Prince, with the title of prince of Aquitaine. There Pedro the Cruel took refuge from Castile, and young Edward undertook to replace him on his throne. He marched through the valley of Roncesvalles and by Pamplona to the frontiers of Castile, met and defeated Henry of Trastamare on the plains between Navarrete and Najera, was disappointed of the reimbursements which had been stipulated, and returned into Guienne with an exhausted treasury and a shattered constitution. To defray the expenses of his court, perhaps the most magnificent in Europe, and to fulfil his contracts with the troops that had followed him to Spain, he imposed taxes which made him unpopular with his barons. Summoned in 1369 to answer before King Charles of France to the complaints of his vassals, he replied that he would obey, but at the head of 60,000 men. He appeared in the field, but the French generals avoided an engagement and garrisoned their strong places. He laid siege to Limoges, captured it and reduced it to ashes, and massacred the inhabitants. This was the end of his military career, and by the advice of his physicians he returned to England, where he lingered for six years. The Black Prince is portrayed by contemporary writers as the most heroic of princes. He married his cousin Joan, countess of Kent, famed for her beauty, by whom he left one son, Richard, who succeeded Edward III. as king.

**EDWARDES**, Sir **Herbert Benjamin**, an English soldier and author, born at Frodesley, Shropshire, Nov. 12, 1819, died Dec. 23, 1868. He studied at King's college, London, entered the East Indian service, was wounded in the battle of Moodkee, December, 1845, and participated in the victory of Sobraon, February, 1846. When Moolraj, in April, 1848, stirred up a rebellion of the Sikhs, it was the courage and skill of Lieut. Edwardes that saved the British power in the Punjab. With Col. Cortlandt he moved down the W. bank of the Indus at the head of 7,000 men, and crossed the stream with a small body of infantry to attack the enemy. He was confronted by a force of 12,000 men, and after a hard-fought battle, memorable for a gallant charge of the mounted British officers upon the Sikh front, the insurgents were routed by the opportune arrival of Col. Cortlandt, and made their way to Mooltan. In the subsequent siege of that city and its assault he gained new laurels, but lost his right hand by the accidental discharge of a pistol. He finally reached the rank of major general. After the war he visited England, married, and pub-

lished "A Year on the Punjaub Frontier" (2 vols. 8vo, London, 1851). He afterward returned to India, and in 1864 was appointed lieutenant governor of the Punjaub. His "Life of Sir Henry Lawrence" was completed by Herman Merivale (London, 1872).

**EDWARDS, I.** An unsettled S. W. county of Texas; area, 1,225 sq. m. It is chiefly noted for its mountain cedar, cold springs, and large rocks. **II.** A S. E. county of Illinois; area, 200 sq. m.; pop. in 1870, 7,565. Bon Pas creek flows along its E. border, and the Wabash touches it on the S. E. The surface is occupied by forests and fertile undulating prairies. The chief productions in 1870 were 122,703 bushels of wheat, 352,371 of Indian corn, 129,152 of oats, 14,522 of potatoes, 7,374 tons of hay, 48,703 lbs. of wool, and 133,150 of tobacco. There were 2,952 horses, 2,045 milch cows, 2,900 other cattle, 14,401 sheep, and 13,274 swine. Capital, Albion.

**EDWARDS, Amelia Blandford**, an English novelist, born in 1831. She early exhibited literary and artistic tastes, and in 1853 began to contribute to periodicals. She has written an "Abridgment of French History," a school history of England, a volume of ballads, and several books for children, the most successful of which are "The Little Marquis" and "The Story of Cervantes." But she is best known by her novels: "My Brother's Wife" (1855), "The Ladder of Life" (1857), "Hand and Glove" (1859), "Barbara's History" (1864), "Half a Million of Money" and "Miss Carew" (1865), "Debenham's Vow" (1870), and "Monsieur Maurice and other Tales" (1873).

**EDWARDS, Bela Bates**, an American author and editor, born in Southampton, Mass., July 4, 1802, died in Georgia, April 20, 1852. He graduated at Amherst college in 1824, entered the seminary at Andover in 1825, in 1826 was appointed tutor at Amherst, and in 1828 was chosen assistant secretary of the American education society, and performed the duties of this office till 1833. His literary and editorial labors were very great and important. From 1828 to 1842 he edited for the education society the "American Quarterly Register." In 1833 he established the "American Quarterly Observer," which, after three volumes, was united with the "Biblical Repository" of Prof. Robinson, which he edited from 1835 to 1838. Of the "Bibliotheca Sacra" he was the editor from 1844 to 1852. In 1837 he was appointed professor of Hebrew in the seminary at Andover; and in 1848 of Biblical literature, which office he held till his death. He prepared the "Eclectic Reader," "Biography of Self-taught Men," "Memoirs of E. Cornelius" (1842), a volume on the Epistle to the Galatians, and the "Missionary Gazetteer" (1832). A selection of his sermons, lectures, and addresses, with a memoir by Prof. Park (2 vols. 12mo), was published in Boston in 1853.

**EDWARDS, Bryan**, an English historian, born in Westbury, Wiltshire, May 21, 1743, died

July 15, 1800. After acquiring a good English education at Bristol, he emigrated to Jamaica in 1759, where a rich uncle gave him the means of completing his studies, and made him his heir. He became a prominent member of the colonial assembly, and published in 1784 a pamphlet against the restrictions laid by government on the trade between the West Indies and the United States. He afterward went to Santo Domingo, and collected materials for his "Historical Survey of the French Colony" in that island (4to, London, 1797), which was incorporated in the author's best known work, "The History, Civil and Commercial, of the British Colonies in the West Indies" (2 vols. 4to, London, 1793; 3d ed., 3 vols. 8vo, 1801; 5th ed., with a continuation to 1796, 5 vols. 8vo, 1819). This work bears a high character, and gives very minute and varied information. Mr. Edwards returned to England, and from 1796 till his death represented Grampond in parliament.

**EDWARDS, George**, an English ornithologist, born in Stratford, Essex, about 1693, died July 23, 1773. He was brought up to trade, but developed a taste for natural history and antiquities, and at the close of his apprenticeship visited Holland, Norway, and other parts of Europe, in prosecuting his favorite researches. The fruit of his labors appeared in his "Natural History of uncommon Birds, and of some rare and undescribed Animals" (4 vols. 4to, London, 1743, '47, '50, and '51); to which three more volumes were added in 1758, '60, and '64, called "Gleanings of Natural History." This exceedingly valuable work contained numerous plates, with descriptions in French and English of more than 600 subjects. In its original form it is scarce, but several partial editions and abridgments have been published. He left a work entitled "Elements of Fossilology," which appeared in 1776.

**EDWARDS, John**, an English divine, born in Hertford, Feb. 26, 1637, died in Cambridge, April 16, 1716. He graduated at Cambridge in 1661, and took charge of Trinity church there, thence removed successively to Bury St. Edmund's, to Colchester, and back to Cambridge. In 1699 he was made doctor of divinity; and from this time he became a voluminous writer, showing himself a subtle, able, and learned polemic. He was a very earnest Calvinist, and from his abhorrence of Arminianism connected it with popery. His most important works are "Veritas Redux, or Evangelical Truths Restored;" "Inquiry into four remarkable Texts;" "Discourse concerning the Authority, Style, and Perfection of the Books of the Old and New Testaments;" "Survey of the several Dispensations of Religion;" "Answer to Dr. Whitby's Five Points;" "Animadversions on Dr. Clarke's Scripture Doctrine of the Trinity;" and "*Theologia Reformata*: the Body and Substance of the Christian Religion." He wrote also several treatises against the Socinians.

**EDWARDS, Jonathan**, an American divine and metaphysician, born at East Windsor, Conn., Oct. 5, 1703, died at Princeton, N. J., March 22, 1758. He was an only son, with ten sisters, four of whom were older than himself. His father and his mother's father were eminent ministers; he sprung directly from John Warham, the west of England minister who reached America a week or two before Winthrop, settled first in Dorchester, and then with a part of his flock removed to Windsor. He was trained by his father and his elder sisters for college and to habits of careful study and analysis. The community in which he lived was eminently religious, and before he was ten years old his religious sensibilities were strongly aroused. His childhood was troubled with anxious doubts as to the divine sovereignty. At the age of ten he wrote a paper ridiculing the idea that the soul is material. He early showed quickness and accuracy of observation; when twelve years old he sent to a European correspondent of his father an account "of the wondrous way of the working of the spider" in the forest, whose habits he had watched. In September, 1716, he entered Yale college. He gained a good name for "his carriage and his learning;" but in his scanty opportunities the range of his learning was very limited. He knew little of classic literature; the best impulse to his mind was given by Locke's "Essay on the Human Understanding," which he read with delight. But he was quickened, not subdued or mastered, by Locke's system, which turned him to speculative activity. He inclined to that system which in Europe had found its representatives in Malebranche and Leibnitz; and, probably from citations, something of Plato's theory of ideas, and something of the doctrine of Cudworth's "Intellectual System," infused themselves into his reflections. When about 15, in opposition to Locke, he denied the possibility of adding to matter the property of thought, and held that "everything did exist from all eternity in uncreated idea;" that "spirit or mind is consciousness and what is included in consciousness;" that "truth is the agreement of our ideas with the ideas of God;" that "nothing has a proper being but spirit;" that "matter is merely ideal;" that "the objects of the external senses are but the shadows of being;" that "the universe exists nowhere but in the divine mind." His speculations have sometimes a startling resemblance to those of Spinoza. The latter calls thought and extension the "attributes of God," and ascribes being to God alone; Edwards wrote that "space is God." In one of his latest works he says of God, "He is all and alone;" "the infinite, universal, all-comprehending entity." In his youth he said, "God and real existence are the same; God is, and there is none else." While a collegian he argued out for himself his theory of the will and his theory of virtue. One thing more was wanting to shape his

course. He counted himself still among the unregenerate; but after an illness in his last year in college, when not yet 17, how or by what means he could never tell, "his past convictions" were overcome, and he had no more doubts of "God's absolute sovereignty and justice with respect to salvation and damnation." Now he had found the purpose of his life; his speculative opinions and his religious faith were unalterably formed. He had no less than Locke a disposition to show the harmony between reason and religion, the faculties of man and the dogmas of the true faith; but from the first he repelled the materialist philosophy; and while he never came forward as the express combatant of Locke, it became from his early youth the object of his earthly career to combat the results of Locke's philosophy in its application to the sources of knowledge, the science of morals, and theology. His sense of divine things would often of a sudden kindle up "a sweet burning in his heart." He gave an account of his experience to his father, and united with the church. For two years after he took his degree he remained in New Haven as a student for the ministry; and in August, 1722, he was selected to preach in a Presbyterian church in the city of New York. Here he remained eight months, and here on Jan. 12, 1723, he made anew a solemn dedication of himself to God. In April, 1723, he returned home, and at his father's house in East Windsor continued his studies, made with the pen in hand. Here he finished a series of 70 resolutions, in regard to which he humbly entreated God by his grace to enable him to keep them all: to act always for the glory of God, for the good of mankind in general; to lose not one moment of time; to live with all his might while he did live; to let the knowledge of the failings of others only promote shame in himself; to solve as far as he could any theorem in divinity he might think of; to trace actions back to their original source; to be firmly faithful to his trust; to live as he would if it were but an hour before he should hear the last trumpet; to strive every week for a higher and yet higher exercise of grace; "to keep a benign aspect, and to let there be something of benevolence in all his speech." In September, 1723, several congregations invited Edwards to be their minister; but he declined every proposal, reserving two years more for study. In June, 1724, he became tutor in Yale college. In the summer of 1726 he was invited to become the pastor at Northampton, as the colleague of his grandfather, Solomon Stoddard; and on Feb. 15, 1727, he was ordained to his office. On July 28 he married Sarah Pierrepont, daughter of a minister at New Haven. In February, 1729, the senior pastor died, and the young minister was left alone. It was his habit to rise early, and study during the whole day. He made no visits unless sent for by the sick or the sorrowing, but encouraged persons under religious

impressions to come to consult him. In spite of this comparative seclusion, and in spite of a weak and infirm constitution, he was an acceptable pastor, and his fame as a preacher was very wide. The little exercise which he took consisted in solitary walking or in rides on horseback in the lonely woods. In July, 1731, he was prevailed upon to deliver the Thursday lecture in Boston; and his discourse was printed and greatly approved. It was his habit to write out his thoughts with care, but to utter himself fluently without regard to his notes. His voice, though not strong, was clear and distinct; and his manner, though he used little of gesture, showed his own fervor and moved the hearts of his hearers. The Arminian doctrine seemed to him of the most dangerous practical tendency, and in 1734 he began to preach on justification by faith alone. His preaching was followed by a wonderful revival of religion, exceeding everything that had been known at any time in any part of the country. On this occasion he printed a sermon on "A Divine and Supernatural Light imparted to the Soul by the Spirit of God," and he wrote a narrative of this great awakening, which was printed in England, and republished in Boston, with some doctrinal discourses against the Arminians. The revival began to extend far and wide through the New England colonies, having a permanent influence on the character of the people and their conduct in events that were soon to come. Tradition still keeps in memory the wonderful effect of Edwards's sermon at Enfield on sinners in the hands of an angry God. He wrote "Thoughts on the Revival of Religion," and published in 1746 his "Treatise concerning Religious Affections." His life was now destined to meet with seemingly one of the saddest of afflictions. Edwards noticed among his people levities of manner, consequent as it seemed on reading books which a severe morality could not approve, and he invoked the attention of his church to the subject. The church disapproved of the scandal which would follow an inquiry, and let the matter drop. Under the lax discipline of his predecessor the church had been filled up with persons who, though outwardly well behaved, were not strictly religious. Calvin and the Congregationalists admitted to the communion only those who professed personal religious convictions, and baptized only the children of communicants. On this system the churches of Massachusetts and Connecticut were founded. But the Roman Catholic and the Lutheran and Anglican churches baptized all children born within their pale; and the influence of their example made the New England people generally desire to secure the ordinance of baptism for their offspring, and the "half-way covenant" was adopted. Edwards desired to enforce the old rule, which in the Northampton church had never been abrogated, and found himself at variance with the church. He held

that experimental piety should go before admission to full communion; the church held that the Lord's supper is a converting ordinance. Edwards was overborne by the majority. He proposed to deliver a course of lectures on the subject, and they refused him their consent; and on June 22, 1750, he was forced to resign. His friends in Scotland invited him to come over and establish himself in that country; Samuel Davies of Virginia entreated him to remove to that state, offering to surrender to him his own parish, and pleading that he and he only had weight enough by his representations in Great Britain to stop the illiberal oppression of Presbyterians by the governors of the Old Dominion. But he accepted an offer from the agent of the London society for propagating the gospel, to become a missionary to the remnant of the Housatonic Indians at Stockbridge. The handful of white settlers that had gathered round the tribe also asked him to become their pastor. His trifling income was slightly augmented by the delicate handiwork of his wife and daughters, which was sent to Boston to be sold. At Northampton Edwards had been the centre of a wide circle of influence, visited by many guests, consulted by many churches; at Stockbridge all his preaching to the Indians was uttered extempore, without notes, aided by an interpreter; and when he was once established in a house of his own, he found himself possessed of more leisure than he had ever before enjoyed. The next six years were given to uninterrupted study. The narrow apartment that formed his workroom found him early and late at his desk; he scarcely shared the meals of his family. The development of the views which had long engaged his mind formed the chief entertainment and delight of his life. The main point in the discussion between Arminians and Calvinists had been carefully considered by him from the time he was 15 years old, and he had kept minutes of his thoughts during the intervening period. He now finished his "Inquiry into the Freedom of the Will," and published it in 1754. After a half year's illness he completed a dissertation on "God's Last End in the Creation of the World," which is a picture of his own character, reasoning, and mind. He also wrote at this period his dissertation on the "Nature of True Virtue," and his essay on "Original Sin," and planned a comprehensive work on Christian theology in the form of a history, a revision and completion of the history of redemption which he had written at Northampton, to be carried on with regard to all three worlds, heaven, earth, and hell. Plans of other treatises crowded also upon his mind. These studies were interrupted by the death of his son-in-law, President Burr of Princeton college, and Edwards was called to succeed him. He kindled by his presence and his words the liveliest interest among the students, and on Feb. 16, 1758, was installed as president. The



smallpox was prevailing in the neighborhood, and he was inoculated; but the disease took an unfavorable turn, and he died 34 days after his installation, at the age of 54. In 1872 his descendants erected to his memory at Stockbridge a monument of red granite, 25 ft. high.—In considering the writings of Jonathan Edwards, the first thing to be borne in mind is his unquestioning acceptance of the truth of the Holy Scriptures, of every event recorded there, every miracle, and every prophecy; the actual fall of man, the incarnation, death, resurrection, and ascension of Christ. The next is, the intensity of his attachment to the system of Calvinism as opposed to that of Arminianism. These points being premised, the characteristics of all that Edwards has written are threefold. He looks always to establish the reasonableness of his views. The doctrine of a divine incarnation, for example, approves itself, as he thought, to human reason; and he cites in proof the authority of Greeks and Romans, the most philosophical nations of the world, and refers to the *anima mundi* of Blount and the pantheism of Spinoza. He scoffs at the pretensions to greater liberality of the Arminians, and puts reason and common sense on the side of orthodoxy. He thought there was no need that the strict philosophic truth should be at all concealed. "The clear and full knowledge of the true system of the universe will greatly establish the doctrines which teach the true Christian scheme of divine administration in the city of God." Least of all would Edwards give up the individual right of free inquiry, for he says: "He who believes principles because our forefathers affirm them, makes idols of them; and it would be no humility, but baseness of spirit, for us to judge ourselves incapable of examining principles which have been handed down to us." He knows no scheme of Christianity that is the fruit of time; the divine administration began from eternity and reaches forward to eternity. The third great feature of his mind is its practical character. His system has in view life and action; he puts aside all merely speculative questions, and while he discusses the greatest topics, it is only because of his overwhelming consciousness of their important bearing on conduct and morals. He moves in the real world, and brings theology down from the dim clouds of speculation to the business and the bosoms of the universal people. It is a strange misconception about Edwards, that he drew his philosophy from Locke. In the want of books, the essay of Locke trained him to philosophical meditation; but his system was, at its foundation and in every part, the very opposite of the theory of Locke. On the subject of the origin of ideas he accords with Leibnitz. The doctrine that all truth is derived from sensation and reflection he discards. The knowledge of spiritual truth he considers "a new principle," "the divine nature in the soul." "It is the Spirit of God that gives

faith in him," were the words of his sermon at the Boston lecture in 1731; and three years later he enforced at large that it is a doctrine of reason that "a divine supernatural light is immediately imparted to the soul by the Spirit of God." He teaches that knowledge of spiritual truth cannot be derived from the senses; it is a wisdom not earthly or natural, but descending from above; "it is the image and participation of God's own knowledge of himself." In like manner he finds the idea of causality "implanted by God in the minds of all mankind." As a consequence, the contrast of Edwards with Locke and those who came after him appears equally in the different manner in which they sought to establish the truth of Christianity. The disciples of Locke's philosophy cling to the historical evidence from miracles as the principal proof of the Christian religion. Edwards, on the contrary, laid down the principle that "no particular sort of outward representations can be any evidence of a divine power." "Unless men may come to a reasonable, solid persuasion and conviction of the truth of the gospel, by the internal evidences of it, by a sight of its glory, it is impossible that those who are illiterate and unacquainted with history should have any thorough and effectual conviction of it at all." "It is unreasonable to suppose that God has provided for his people no more than probable evidences of the truth of the gospel. It is reasonable to suppose that God would give the greatest evidence of those things which are greatest, and the truth of which is of the greatest importance to us. But it is certain that such an assurance is not to be attained, by the greater part of them who live under the gospel, by arguments fetched from ancient traditions, histories, and monuments."—The theory of Edwards respecting providence corresponded with that of Leibnitz. To him the laws of nature were not established and left to themselves, but were the methods according to which God continued his "immediate influence." "His preserving created things in being is equivalent to a continued creation." The presence of moral evil, the depravity of human nature, he considered from two points of view. He raised his mind to the contemplation of God as the Creator, and had then no theory to offer for man's depravity but the divine will. He never presumed to ask Almighty God why it was so. But to those who questioned this absolute sovereignty, and rejected it as a doctrine full of horror, he made a twofold answer, not as finding excuses for the Creator, but subjectively as shutting the mouth of cavillers: First, that man's depravity is an unquestionable fact; that through the medium of his senses and merely animal organization man can attain to no knowledge of God and no spiritual perfection. Secondly, he set forth the unity of the race; its common constitution as branches from one root, forming one complex person, one moral whole;

which is the view of Augustine and Calvin. This view also had a most important bearing on the theory of morals. The momentous question of man's relation to moral evil, and the way of his escape from it, formed one of the chief objects of Edwards's thoughts during his whole life. "Men in a very proper sense may be said to have power to abstain from sin, because it depends on the will;" and if they will not, the defect is in themselves; yet a man's evil disposition may be as strong and immovable as the bars of a castle. The law of causality extends to every action. Liberty consists in the power of doing what one wills, not in any power of willing without a motive. The will always follows the greatest seeming good; and what shall seem to a man the greatest good depends on the state of his soul. Liberty is not in the act, but in the man; and if a depraved nature is to abstain from sin, it can only be effected by a change of heart. This theory Edwards asserted by an appeal to the facts of universal experience, and by a thorough analysis of the complex cause of action. In his essay on the "Nature of Virtue" he finds it to consist in love; not in love as resting complacently on its objects, but in love as the ruling motive of the will; love in action, benevolence. And this love is not for self; the doctrine of Edwards is the intensest protest against the theory of self-love. Taking Christ's summary of the law under two commandments of love to God and love to one's neighbor, he finds a general term which includes both God and man in "Being," and he therefore defines virtue as the "love of Being." Thus virtue implies the love of God with all the soul, for God is the Being of beings, "in effect, Being in general." The love to universal Being includes all being, each in its degree, according to its amount of existence; active love for the good of the world of mankind before the love of country, of country before that of a single city, of a city before a family, of the family before the individual, of the individual only in subordination to the great system of the whole. The theory is the opposite of that which makes self-love the foundation of moral order. It does not weaken the bonds of family affection; only the love of wife or husband, parent or child, must not be the paramount motive. In this light the doctrine of the oneness of the race, which Edwards asserted with great clearness and force, gains new significance.—The ethical theory of Edwards is cosmical. It is universal history resting on the principle of the redemption of the world, decreed from all eternity; the gradual progress and advancement of the race through the presence of the Divine Word and its ever approaching triumph over all enemies. Events seem confused like the work of an architect, who employs many hands in many kinds of labor at once; but a knowledge of the design removes all appearance of confusion; and so the design of the Divine Word in redemption

gives unity to the history of all the nations of the earth. The development of this idea employed the latest thoughts of Edwards, though his "History of Redemption" is only a sketch of the great work which he planned.—Edwards makes a turning point in the intellectual, or, as he would have called it, the spiritual history of New England. New England and New Jersey, in the age following him, applied more thought to the subject of religious philosophy and systematic theology than the same amount of population in any other part of the world; and his influence is discernible on every leading mind. Bellamy and Hopkins were his pupils; Dwight was his expositor; Smalley, Emmons, and many others were his followers; through Hopkins his influence reached Kirkland, and assisted in moulding the character of Channing. Edwards sums up the old theology of New England, and is the fountain head of the new.—There are several lives of Jonathan Edwards. The most interesting is that by Hopkins, who was his pupil; the fullest is that by Sereno Edwards Dwight. There have been two editions of his works in England, one in 8 vols. 8vo, and one in two compact volumes. The American editions are to be preferred. One was published at Worcester, Mass., edited by Samuel Austin, in 1809, in 8 vols. The New York edition is by Sereno E. Dwight, in 10 vols. 8vo, of which the first contains the life. There is also a later and convenient New York edition in 4 vols.

**EDWARDS, Jonathan**, president of Union college, Schenectady, N. Y., son of the preceding, born in Northampton, Mass., May 26, 1745, died in Schenectady, Aug. 1, 1801. At the age of six he went with his parents to Stockbridge, where there was but one school for both Indians and whites, of the latter of whom there were so few that he was in danger of forgetting the English tongue. He thoroughly learned the language of the Stockbridge Indians, and in later years published a treatise on the subject. In his 10th year he was sent by his father with the Rev. Gideon Hawley among the Six Nations, that he might also learn their language and become qualified to be a missionary among them. Here he made rapid progress; but owing to the disturbances of the French war, he soon returned to Stockbridge. In 1761 he entered the college at Princeton, N. J., where he graduated in 1765. He studied divinity with Dr. Bellamy, and in 1766 was licensed to preach. In 1767 he became tutor in the college at Princeton. In 1769 he was ordained as pastor of the church in White Haven, in the town of New Haven, Conn., where he continued till May 19, 1795. Resigning his charge, mainly on account of difference in doctrinal views between himself and some of his people, he was settled in 1796 as pastor of the church in Colebrook, where he gave much time to study, and to an extensive correspondence with learned men in America and in Europe. In May, 1799, he was

elected president of Union college, but only lived two years after his inauguration. His complete works, edited with a memoir by his grandson, the Rev. Tryon Edwards, D. D., were published in 2 vols. at Andover in 1842.

**EDWARDS, Justin**, an American clergyman, born in Westhampton, Mass., April 25, 1787, died at Virginia Springs, July 23, 1853. He graduated at Williams college in 1810, settled in the ministry at Andover in 1812, removed to the Salem street church, Boston, in 1828, and in 1829 resigned this charge to become secretary of the American temperance society, in the service of which he was engaged for seven years, delivering lectures and addresses, and preparing the "Temperance Documents." After this, he was for six years president of the Andover theological seminary. He wrote the "Sabbath Manual," and spent four years in preparing a brief commentary on all the New and part of the Old Testament, for the American tract society, before finishing which he died. He was the author of several valuable tracts, some of which have had a wide circulation. Of his "Temperance Manual" and of the different parts of his "Sabbath Manual" many hundred thousand copies have been printed. A memoir of his life and labors was published by the American tract society in 1855.

**EDWARDS, Milne.** See MILNE-EDWARDS.

**EDWARDS, Richard**, an English dramatist, born in Somersetshire in 1523, died about 1566. He was educated at Corpus Christi college, Oxford. His "Damon and Pythias" was the first English tragedy on a classical subject, and was acted before the queen at Oxford about 1566. All his other dramas are lost. He wrote several minor poems, of which *Amantium Ira* has been often reprinted.

**EDWARDS, Tryon**, an American clergyman and author, grandson of the younger Jonathan Edwards, born in Hartford, Conn., Aug. 7, 1809. He graduated at Yale college in 1828, studied law in New York and theology at Princeton, and settled in the ministry at Rochester, N. Y., in 1834. He removed in 1845 to New London, Conn. In 1832 a prize tract on Sabbath schools appeared from his pen, and he has from that time contributed constantly to the religious press. Among his publications are an address delivered at Williams college in 1841, entitled "Christianity a Philosophy of Principles," a memoir of the younger President Edwards, published with his complete works (1842); "Self-Cultivation" (1843); and a memoir of Dr. Bellamy, published with his complete works (1850). He has edited a volume entitled "Charity and its Fruits," from the MSS. of the elder President Edwards, and several collections designed especially for domestic culture, as "Select Poetry for Children and Youth" (1851), "Jewels for the Household" (1852), "The World's Laconics" (1852), and "Wonders of the World" (1855). He was long editor of the "Family Christian Almanac."

**EDWIN**, king of Northumbria, born about 586, ascended the throne in 617, and died in 633. He was an infant when at the death of his father, Ælla, king of Deira, the throne was usurped by his brother-in-law, Ethelfrid, king of Bernicia, who in 593 united the two kingdoms under the name of Northumbria. Edwin was placed by his friends under the protection of Cadvan of North Wales. The British prince was assailed by the Northumbrian, and the two armies met in the vicinity of Chester. Victory decided for Ethelfrid; a body of monks who had stationed themselves on a neighboring hill to deprecate the success of the invader were put to the sword, and the great monastery of Bangor, containing 2,100 monks, was demolished. Edwin then wandered through the different principalities of the Britons and Saxons, till he found an asylum at the court of Redwald, king of the East Angles. Redwald made war on Ethelfrid; the armies met in 617 on the banks of the Idle, in Nottinghamshire; Ethelfrid was defeated and slain, and Edwin without further opposition ascended the throne. The martial genius of Edwin raised Northumbria to preëminence among the Anglo-Saxon states. The islands of Anglesea and Man became subject to his authority, all the princes of the Britons paid him tribute, and among the Saxon kings Eadbald of Kent alone retained a nominal independence. So inflexible was his administration of justice, that in his days it was a common saying that a woman or a child might openly carry everywhere a purse of gold without danger of robbery. The chief event of his reign was the introduction of Christianity into the kingdom of Northumbria. He married Ethelburga, a princess of Kent, daughter of that Bertha by whose influence the king and people of Kent had been already converted to Christianity. Yet neither the entreaties of the young queen, the arguments of the learned bishop Paulinus, nor the letters and presents of Pope Boniface V., could for a long time turn him from the worship of his fathers. He consulted alternately the priests on either side, revolved in solitude their opposite arguments, assembled the witenagemote for consultation, and at last avowed himself a convert, and was followed by his people. Edwin perished in a disastrous battle with the combined armies of Penda, king of Mercia, and Ceadwalla, king of the Britons, who had raised the standard of rebellion, and marched into Yorkshire; and the kingdom was soon after recovered by Oswald, son of Ethelfrid.

**EDWY**, surnamed the Fair, a king of the Anglo-Saxons, son of Edmund I., and successor of his uncle Edred, born about 938, ascended the throne in 955, and died at the close of 958. He was passionate and dissolute. Having on the day of his coronation retired from the banquet to the apartment of a young princess named Elgiva, he was violently taken back to the table by St. Dunstan, whom he then ban-

ished from the kingdom. Archbishop Odo broke with an armed force into the villa where Elgiva resided, defaced the beauty of that lady with brands, and exiled her to Ireland; but she returned to England, where she suffered hamstringing and died. It is in dispute among historians whether Elgiva, who was within the prohibited degrees of consanguinity, was the wife or the mistress of Edwy. The English favored the ecclesiastics rather than the king, and a rebellion broke out under Edgar, a younger brother of Edwy, who was chosen king by the Mercians. Edwy was obliged to flee beyond the Thames, and the civil war was ended in 957 by a general meeting of the thanes, who determined that that river should be a boundary between the dominions of the two brothers. Edwy governed Wessex and Kent till his death.

**EECKHOUT**, or **Eekhout**, **Gerbrant van den**, a Dutch painter, born in Amsterdam, Aug. 19, 1621, died there, Sept. 22, 1674. He was a pupil of Rembrandt, and in some measure successful in imitating his manner, especially in the early part of his life. He excelled chiefly in portraits, and these as well as his historical pictures abound in the best collections of Holland, while several are to be found in Germany.

**EEOLOO**, or **Eecloo**, a town of Belgium, in the province of East Flanders, 11 m. N. W. of Ghent; pop. in 1866, 9,564. It has an active industry and commerce in woollen and cotton fabrics, hats, tobacco, and oil, and is an important grain market.

**EEL**, a name applied to several malacopteron fishes of the families *anguillidæ*, *congeridæ*, and *murænidæ*, especially to the typical genera *anguilla* (Cuv.), *conger* (Cuv.), and *muræna* (Thunb.). From their snake-like appearance, and the absence of ventral fins or posterior limbs, they have been called anguiform *apodes*; they all have the body more or less elongated and cylindrical, no ribs in the skeleton, a cæcal stomach, and simple not-jointed fin rays. In the genus *anguilla*, to which the common eel belongs, the scarcely apparent scales are cycloid, narrow, oblong, arranged in groups at right angles to each other, forming a kind of lattice-work under the cuticle; the whole skin is soft and slimy, thickly studded with muciparous glands and ducts; the nostrils are double, each having two orifices, the anterior prolonged into a tube, and the posterior opening above the mouth; the teeth are card-like or villiform in both jaws, and a few on the anterior part of the vomer; the gill opening on each side is very small, and just in front of the pectoral fin, which exists in all the species; the dorsal fin begins at a considerable distance from the head, behind the pectorals, and forms a continuous fin with the caudal and anal; the lower jaw is longer than the upper. About 50 species are described. The common eel of the northern and middle states (*A. Bostoniensis*, Lesueur, and *vulgaris*, Mitch.) is greenish or olive-brown above, and yellowish or yellowish white be-

neath, often with a reddish tinge along the anal fin; in a specimen 2 ft. long, measured by Dr. Storer, the short pectorals were about 8 in. from the end of the snout. The eel inhabits both salt and fresh water, from the British provinces to the southern states, wherever it can find its favorite muddy bottoms and extensive flats; it prefers shallows near the shore, where it may be caught in great numbers by hook and line, by bobbing, and by spearing; the places frequented by it are called eel grounds, in which during winter the fishes bed themselves in the soft mud to the depth of about a foot, and are then speared through holes cut in the ice; the best time for catching them is at night, by torchlight. During their passage up and down rivers they are taken in baskets and pots baited with fish or any decaying matter. The eel is very voracious and quite omnivorous; when in good condition it is well flavored, though from its snake-like appearance (and it is only in form that it resembles a snake) most persons are prejudiced against it. The length varies from 6 in. to 2½ ft.; in summer it is sometimes seen weighing several pounds. At the mouths of the rivers emptying into Boston

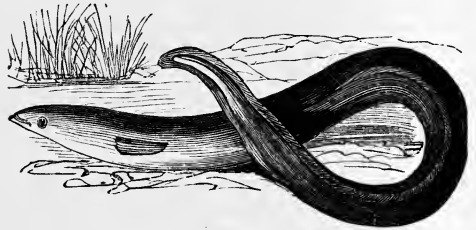

Common Eel (*Anguilla vulgaris*).

harbor eels are caught in nets, 15 or 20 bushels at a time, and are kept alive until wanted in ditches supplied by the tide. The silver eel (*A. argentea*, Les.) is silvery gray, darker above, and satiny white below; the pectorals are nearer the head than in the common species, of which, however, it is considered by some only a variety; it is taken in pots in October, when it leaves the ponds. A large species, caught in the lakes of western New York, is the beaked eel (*A. rostrata*, Les.); the snout is elongated and pointed; the upper parts are olive-gray, sometimes slaty blue, and the lower parts white; the dorsal and anal fins reddish; length about 2 ft. The common eel of Europe (*A. acutirostris*, Yarrell) has a sharper snout than ours; it is highly esteemed as food, and the London market is supplied principally from Holland, from which the eels are brought alive in vessels carrying each from 15,000 to 20,000 lbs. Eels are much esteemed in other countries, especially, according to Ellis, in Polynesia, where they are often tamed and fed until they attain an enormous size. They are prolific, hardy, and easily preserved in salt, fresh, or brackish water. They make two migrations annually, one in autumn to the sea, the other in

spring or summer from the sea to the rivers. They are not found in arctic regions, nor in the rivers of the extreme north of Europe; even in temperate regions, at the approach of winter, they bury themselves in the mud, remaining torpid until spring; they remain without food, breathing hardly at all, at a low animal temperature, and almost motionless; yet the irritability of the muscular fibre is very great, as is shown by the restless motions of eels during thunderstorms, and by their well known movements after the skin has been removed. Though not possessing the respiratory pouches of the anabas, the eel is able to survive a long time out of water, simply because the gills remain moist from the small size of the branchial orifices; by this means it traverses considerable distances on land, moving like a snake through the grass; this explains the appearance of eels in fish ponds from which the utmost care has been taken to exclude them, on account of their destruction of the spawn and young of more valuable fishes; they have been often seen performing such overland journeys at night. Eels are found in fresh water which has no communication with the sea; having a capacious air bladder, they are able to ascend rapidly to the surface, and sometimes swim very high in deep water; though slow of growth, they attain a large size under favorable circumstances, having been caught in England weighing 27 lbs. The town of Ely is said to have been so named from the rents having been formerly paid in eels, the lords of the manor being annually entitled to more than 100,000; Elmore, on the Severn, was so called from the immense number of these fish there taken; so also Aalborg (Eel Town) in Denmark, &c.—The conger eels differ from the genus *anguilla* in having the dorsal fin begin nearer the head, at or even in front of the pectoral, and in having the upper jaw the longer; the anterior nostrils open by short tubes close to the end of the snout, and the posterior in front of the large eyes; the teeth of the palate and vomer are slender, with chisel-shaped crowns, and closely arranged; the skin is naked and scaleless, and the tail elongated and pointed; in other respects they resemble the common eel. The American conger (*conger occidentalis*, De Kay) is olive-brown

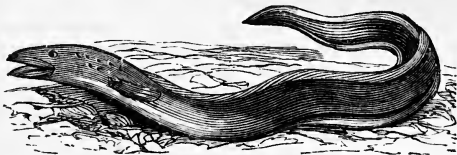

Conger Eel (*Conger occidentalis*).

above and whitish below; the dorsal and anal fins are transparent, with a dark border; the lateral line is distinct, with a series of white dots; it is from 3 to 5 ft. long, and either this or another species is found from the gulf of St. Lawrence southward as far as the coast of

New Jersey. The European conger (*C. vulgaris*, Cuv.) is common on the coast of Cornwall, on the eastern rocky shores, and in banks off the coast of France; it is caught on lines, the best bait being the sand lance (*ammodytes*) or the pilchard, and the fishing is performed at night; great numbers are taken, and meet with a ready sale at a low price to the poorer classes, but it is not held in much estimation. Congers are very voracious, and specimens have been caught weighing 130 lbs., more than 10 ft. long and 18 in. in circumference; they are very strong, bite sharply, and have great tenacity of life. As many as 156 vertebræ have been found in the conger, about 40 more than are found in the eel; they spawn in December and January. Sir John Richardson alludes to nine species.—The eel of the Mediterranean, so famous in the days of ancient Rome, belongs to the genus *muræna*, characterized by the absence of pectorals, smooth and scaleless skin, small lateral branchial orifice on each side, and the united dorsal and anal fins, low and fleshy, hardly distinguishable beyond the margin of the body; the teeth are arranged in a single row around the edge of the nasal bone, with a few on the longitudinal median line. More than 20 species are described, attaining the size of 4 or 5 ft.; one (*M. moringa*, Cuv.) was found by Catesby at the Bahama islands. The classic species of the Mediterranean (*M. Helena*, Linn.), the Roman *muræna*, grows to the length of 4 or 5 ft.; the color is a purplish brown, marked with sub-angular yellow markings, and spotted with beautiful shades of yellow, purple, golden yellow, and white; the anterior nostrils open near the end of the snout, the posterior just above the eyes; the cheeks are rather tumid from muscular development. It has been caught on the English coast, but it abounds in the Mediterranean; great numbers were consumed by the ancient Romans, who kept them in ponds, and placed them alive on the table in crystal vessels, that the guests might admire their beautiful colors before they were cooked. Cæsar is said to have distributed 6,000 of these fishes among his friends on the celebration of one of his triumphs. They are very voracious, fierce, and tenacious of life, and are said sometimes to have been fed on the flesh of slaves who had offended their Roman masters. Their bite is much dreaded by the fishermen. The flesh is white, delicate, and much esteemed. There are many species, exclusively marine.—The sand eel (*ammodytes Americanus*, De Kay) has an elongated, slightly compressed body, large gill openings, a dorsal fin extending nearly the whole length of the back, and an anal fin of considerable size, both separated from the caudal; the lower jaw the longer; the color is yellowish or bluish brown above, mixed with silvery and light green; the sides and abdomen are silvery; the length is from 6 to 12 in. This species is found from the coast of Labrador to that of New York; in the provinces it is largely used as

bait for cod; it is very common in Long Island sound from May to November, constituting in its season the principal food of the bluefish and bass; it is also eaten by eels and other fish; the cephalopod cuttle fish preys upon it extensively; like the tropical flying fish, it is pursued by fishes in the water, and by gulls and terns in the air. The names of sand launce and *ammodytes* are given it from its habit of darting out of and into the sand head foremost and instantly, by means of its projecting lower jaw. Its food is principally insects. On the coast of England it is esteemed as food, and is raked out of the sand at low tide in great numbers; it is also caught in seines. Two species are described.

**EEL, Electrical.** See ELECTRIC FISHES.

**EEL-POUT.** See BURBOT.

**EELS.** See ILIYATS.

**EESAH.** See SOMAULI.

**EFFERVESCENCE** (Lat. *effervesce*, from *ex*, out of, and *fervescere*, to begin boiling), a state of ebullition, without vaporization, caused by the setting free of gases. It may be effected by chemical decomposition, or by diminishing the solvent capacity of a fluid which contains a gas in solution, either by raising its temperature, by diminishing the pressure upon it, or by adding some other body which in dissolving will cause a part of the gas to be expelled. Thus, when a solution of carbonate of soda is mixed with a solution of tartaric acid, the acid and soda unite and carbonic acid gas is set free, causing effervescence. If the solutions are very weak and very cold, the gas may be all absorbed by the water and no effervescence produced. At 65° F., and under the ordinary pressure of the atmosphere, water will absorb about its own volume of the gas. By lowering the temperature or increasing the pressure the amount of the gas absorbed will be increased. In the ordinary soda-water and mineral-water fountains the carbonic acid gas is held in solution under great pressure. When the water is drawn from the fountain into an open glass, the pressure being removed, the gas immediately begins to escape, causing effervescence. The gas is usually made by dissolving marble or chalk, which are carbonates of lime, in hydrochloric or sulphuric acid. It is then cleansed from impurities and forced by great pressure into a condenser, whence it is transferred to the fountains. Effervescence may also be caused by dissolving zinc in dilute sulphuric acid, or zinc or iron in hydrochloric acid. In both cases hydrogen gas is set free. —**EFFERVESCING POWDERS** are preparations of acid and alkaline powders, put up in differently colored papers in order to distinguish them. They are administered by first dissolving the contents of two different papers in separate glasses, then mixing the solutions, and drinking while the chemical reaction is taking place with effervescence. The common soda and Seidlitz powders form effervescing draughts, the acid in one of the papers combining with

the alkali of the carbonate in the other, and expelling the carbonic acid. This gas, continuing to be evolved in the stomach, acts as a refrigerant and diaphoretic, while the alkaline salt is slightly laxative. The drink is especially adapted to febrile complaints. The common soda powders consist of 25 grains of tartaric acid in one paper, and 30 grains of bicarbonate of soda in the other. An equivalent proportion of bicarbonate of potash is sometimes substituted for the soda. The following are the proportions given in the "American Dispensatory": tartaric acid 1 oz., bicarbonate of soda 1 oz. and 54 grains, or bicarbonate of potassa 1 oz. and 160 grains. The acid and either bicarbonate, being separately reduced to fine powder, are divided each into 16 portions. Citric acid is sometimes employed instead of the tartaric acid, in the proportion of 9 drachms to 11 of the soda salt, or 13 of the potash. Seidlitz powders are a mixture of 2 drachms of Rochelle salts (tartrate of potash and soda) and 2 scruples of bicarbonate of soda in one paper, and 35 grains of tartaric acid in the other. The tartaric acid being in excess renders the medicine more pleasant to take, without interfering with its aperient quality. The acid and the carbonate may be prepared in a single powder, in which the chemical action does not take place until it is dissolved in water. Such a preparation should of course be carefully preserved from moisture. Seidlitz and Rochelle powders are more laxative than the common soda powders.

**EFFINGHAM, I.** An E. county of Georgia, separated on the east from South Carolina by the Savannah river, and bounded W. by the Ogeechee; area, 480 sq. m.; pop. in 1870, 4,214, of whom 1,704 were colored. The Georgia Central railroad passes through it. The surface is level, and the soil sandy. Pine and cypress are found. The chief productions in 1870 were 55,854 bushels of Indian corn, 15,932 of sweet potatoes, 294 bales of cotton, and 149,455 lbs. of rice. There were 294 horses, 283 mules and asses, 2,201 milch cows, 4,510 other cattle, 1,238 sheep, and 8,162 swine. Capital, Springfield. **II.** A S. E. county of Illinois, drained by Little Wabash river; area, 500 sq. m.; pop. in 1870, 15,653. The surface is level and partly wooded, and the soil fertile. Copper, iron, and lead are found. The Chicago division of the Illinois Central, and the St. Louis, Vandalia, Terre Haute, and Indianapolis railroads pass through it. The chief productions in 1870 were 195,793 bushels of wheat, 19,759 of rye, 620,247 of Indian corn, 386,073 of oats, 54,671 of potatoes, 11,360 tons of hay, 210,155 lbs. of butter, and 35,650 of wool. There were 4,907 horses, 4,316 milch cows, 5,833 other cattle, 13,228 sheep, and 17,259 swine; 8 flour mills, 12 saw mills, 5 manufactories of saddlery, and 2 of woollen goods. Capital, Effingham.

**EFT,** a name given to several species of newts, especially to the common smooth newt

(*Lissotriton punctatus*, Daud.). The generic characters of the tritons, or aquatic salamanders, will be given under NEWT, which the eft resembles in the slightly free tongue, double longitudinal series of palatal teeth, and nailless toes, four before and five behind. The skin is smooth, and the dorsal and caudal crests are continuous; there are two patches of glandular pores on the head, and none on the back or sides. The newts belong to the genus *molge* of Merrem, and *triton* of Laurenti. Bell separated the efts in the genus *Lissotriton*. The color in the male is brownish gray above, passing into yellowish beneath, which in the spring becomes bright orange; there are numerous round dark spots of unequal size, and two longitudinal streaks on the head; the crest in spring is often tipped with red or violet. The female is light yellowish brown, or buff with brown dots, plainer below. The total length is about  $3\frac{1}{2}$  in., of which the tail is nearly one half. It is very common in the ditches and ponds of Europe, especially where the water is clear; its food consists

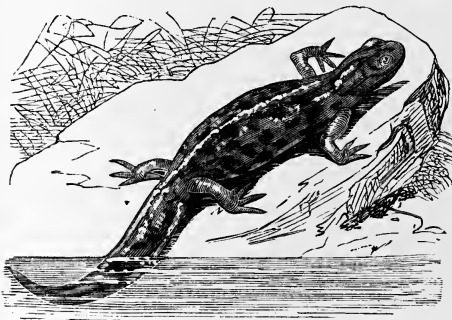

Eft (*Lissotriton punctatus*).

principally of aquatic insects, larvæ, worms, and mollusks. The reproduction and metamorphosis are almost identical with those of the newts. Though usually spending most of their time in the water, the young in June, and the adults in summer and autumn, become terrestrial; they appear to attain their full size the first year. The experiments of Spallanzani show that the members of the tail may be reproduced several times in succession, with bones, muscles, vessels, and nerves. Like the other amphibia, it is very tenacious of life, and can resist even congelation. Its bite is perfectly harmless.

**ÉGALITÉ, Philippe.** See ORLEANS.

**EGBERT**, king of Wessex, and first king of the united Anglo-Saxons, born about 775, ascended the throne of Wessex in 800, and died about 836. The defeated rival of King Brihtric, he took refuge first at the court of Offa, king of Mercia, and afterward in France, where he was received at the court of Charlemagne, in whose armies he served three years. After the death of Brihtric in 800 he was the last

remaining prince of the house of Cerdic, and was recalled and acknowledged as king by the West Saxon thanes. In 809 he commenced his career of conquest; and, successively subduing the Britons of Cornwall and the Saxons of Mercia, Kent, Essex, and Northumbria, and assuming at its request the protectorship of East Anglia, by 827 he had become the actual sovereign of the whole heptarchy, and in 828 assumed the title of king of England. In 832 the Danes landed on the isle of Sheppey, and carried off a rich booty. In 833 they disembarked at Charmouth, and defeated Egbert's forces. They landed again in 835 on the coast of Cornwall, where they formed an alliance with the Britons. Egbert encountered their united forces at Hengston hill, gained a decisive victory, punished the rebels, and drove the invaders to their ships.

**EGEDE. I. Hans**, the apostle of Greenland, born in Norway, Jan. 31, 1686, died in November, 1758. After having been several years a pastor near Drontheim, he resigned in 1717, to embark for Greenland as a missionary. The wars with Charles XII. of Sweden engrossing the public attention, he was unable immediately to execute his design; but he received the patronage of Frederick IV. of Denmark in 1719, set sail in May, 1721, with his wife, two sons, and some 40 other persons, and in July following landed on the coast of Greenland in lat.  $64^{\circ}$  N. His mildness and zeal gained the affections of the rude natives, and after several years of effort he was able to preach the gospel in their language. Various calamities, among which were the ravages of the smallpox, almost annihilated the result of his labors; yet before his departure he succeeded in laying a foundation for the propagation of Christianity and for an important commerce. The Danish government sent out three Moravian Brethren to aid him, and after a residence of 15 years in Greenland, Egede, seeing the colony flourishing, returned to Denmark. He published several works on Greenland, and superintended a seminary for the education of missionaries. **II. Paul**, son of the preceding, born at Waagen, near Drontheim, in 1708, died June 3, 1789. He returned from Greenland in 1728, bringing several Esquimaux, but they all died of the smallpox. After studying theology he went back to the mission, and labored there four years after the return of his father. He translated the "Imitation of Christ" and portions of the Bible into the language of Greenland, and at his departure left the colony highly prosperous. He fulfilled various functions in Denmark, was active in expediting the exploring mission of Lövenön to the coast of Greenland, and at the time of his death occupied a chair of theology.

**EGER** (Boh. *Chéb*), a frontier city of Bohemia, on a river of the same name, at the foot of the Fichtelgebirge, and at the junction of six lines of railway, 91 m. W. of Prague; pop. •

in 1869, 13,463. It has cotton and woollen manufactories, and in its vicinity at Franzensbad are chalybeate springs and baths. Its fortifications, formerly strong, were demolished in 1808. It has a city hall, in which Wallenstein was assassinated, Feb. 25, 1634, the ruins of a castle in which the friends of Wallenstein were murdered, a gymnasium, military school, chamber of commerce, two convents, and four churches.—Eger was formerly the capital of a county of that name, and belonged to the margrave of Vohburg, and passed over by marriage to the emperor Frederick I. In 1270 the city was burned down, and in 1285 the emperor Rudolph gave it as a marriage portion to King Wenceslas of Bohemia. In 1350 a great massacre of the Jews took place here. It was taken and retaken by both Swedes and imperialists during the thirty years' war. In the Silesian wars it was taken by the French under Marshal Saxe in 1742, and again under the marshal de Belleisle in 1745. (For Eger in Hungary, see ERLAU.)

**EGERIA**, one of the Camenæ or nymphs of Roman mythology, who was believed to have dictated to Numa Pompilius his wise laws, and to have instructed him respecting the forms of worship which he introduced. It was said that she became his wife, and that being inconsolable after his death, she was changed into a fountain. She had been worshipped as a rural and prophetic divinity from the earliest periods of Latium, and was invoked as the giver of life by pregnant women. Numa consecrated to her a grove in the environs of Rome, and to strangers visiting that city even now the grotto and fountain of Egeria are pointed out in the beautiful valley of Caffarella. On ancient sculptures this nymph is represented in a costume similar to that of the muses, with floating robe, naked feet, dishevelled hair, and in the attitude of writing in a volume which she holds upon her knees.

**EGERTON, Francis.** See BRIDGEWATER.

**EGERTON, Thomas**, baron of Ellesmere and Viscount Brackley, lord chancellor of England, born at Dobbleson, Cheshire, in 1540, died in London, March 15, 1617. He was educated at Brasenose college, Oxford, was called to the bar, and by his learning and integrity soon attracted the attention of Queen Elizabeth. He was appointed successively solicitor general, attorney general, master of the rolls, and in 1596 lord keeper. James I., on his accession, created him Baron Ellesmere, and appointed him lord high chancellor. He was subsequently elected chancellor of the university of Oxford. In 1616 he was made Viscount Brackley. A few days before his death he resigned the great seal, having retained it, as lord keeper and chancellor, for a longer period uninterruptedly than any of his predecessors or successors. He was succeeded by Sir Francis Bacon. Besides his judicial duties, he was frequently employed by Elizabeth and James in the negotiation of treaties, and in other im-

portant state affairs. His son John was the first earl of Bridgewater (1617), and lord president of Wales.

**EGG**, the organized germinal body from which all animals originate, formed within the mother, and developed into the living being either before or after extrusion. In this article only those of the latter kind, chiefly of birds, will be considered; the general subject will be treated under EMBRYOLOGY. The eggs of many of the lower orders of animals are collected and held together in great numbers by a viscous membrane, and are called spawn. Those of birds and of many reptiles, as the tortoises and turtles, are deposited singly. Birds' eggs are contained in a calcareous shell, white or colored, formed almost wholly of carbonate of lime; the other constituents are minute quantities of animal matter, phosphate of lime, carbonate of magnesia, oxide of iron, and sulphur. Lining this hollow shell is a thin and tough membrane, composed principally of albumen. At the larger end of the egg is a space between the outer shell and this membrane, which, very small when the egg is first laid, increases with its age; it is called the *vesicula ævis*, and is filled with air, in which the proportion of oxygen is larger than in the atmosphere; this is said to be for the respiration of the unhatched chick. Within the membrane is the white of the egg, or the albumen, a viscid liquid, in membranous cells, which encloses the yolk and the real germ of the animal. As this germ leaves the place of its production and passes into the egg-discharging canal, the albumen gathers around it in successive layers, a portion in very delicate membranes, called the *chalazæ*, which are attached to the poles of the yolk, and serve to suspend it in such a manner that the smaller and lighter half must always be uppermost. The outer layer of the albumen is less thick and viscid than that next the yolk; around it the lining membrane and calcareous shell are successively added before the egg is laid. In the hen's egg, the composition of the albumen is: water 85 parts, pure albumen 12, mucus 2·7, and saline matter 0·3, including soda with traces of sulphur; or, according to Dr. Thomson, water 80, albumen 15·5, mucus 4·5, ash 0·475. The yolk, called *vitellus*, is also a glairy fluid, commonly yellow, enclosed in its own membrane, and consists of a great variety of constituents, viz.: water, 41·486; a form of albumen called vitelline, 15·76; margarine and oleine, 21·304; cholesterine, 0·438; oleic and margaric acids, 7·226; phosphoglyceric acid, 1·2; muriate of ammonia, 0·034; chlorides of sodium and potassium and sulphate of potassa, 0·277; phosphates of lime and magnesia, 1·022; animal extracts, 0·4; and 0·553 of coloring matter, traces of iron, lactic acid, &c. Upon one side of the yolk is a round spot, yellowish white, called the *cicatricula*, the germ of the ovum, which by the arrangement of the *chalazæ* already referred to is always kept



uppermost, and next to the source of heat supplied by the animal in sitting. As this is developed into the fetus, the albumen first furnishes nourishment to it, and when this is consumed more is supplied by the yolk. Eggs of the hen are hatched by being kept at a temperature of 104° for three weeks. Their vitality has been retained after they have been exposed to a temperature of 10° F.; and it is a remarkable fact that the freezing point of new-laid eggs is much lower than that of the water and albumen of which they principally consist, both of which congeal at about the same temperature. Eggs that have been once frozen, or have been long kept, freeze at the point their constituents would require. The specific gravity of new-laid eggs is from 1·08 to 1·09; by keeping they diminish in weight from evaporation of water, and the substitution of air through the pores of the shell. This diminution has been observed to continue for two years; an egg weighing originally 907·5 grains being reduced, as remarked by Dr. Thomson, to 363·2 grains. When they have lost so much weight as to float upon water, they are generally unsound. The preventing of this evaporation by covering their surface with a coating of varnish, wax, gum arabic, or lard, checks their putrefaction. The Scotch sometimes drop them into boiling water for two minutes, by which the membrane within the shell is partially coagulated and rendered impervious to air. Hens' eggs vary so much in gravity, that it is a wonder they continue to be sold by numbers instead of weight. A dozen of the largest have been found to weigh 24 oz., while the same number of smaller ones of the same stock weighed only 14½ oz. The fair average weight is about 22½ oz. to the dozen. The relative weights of the portions of the egg as given by Dr. Thomson are: shell and membrane, 106·9; albumen, 604·2; yolk, 288·9. About one third of the entire weight may be regarded as nitrogenous and nutritious matter; a greater proportion than that of meat, which is rated at only from 25 to 28 per cent., while the nutritive portion of the oyster is only about 12 per cent. The white of the egg, from its tendency to coagulate into a hard and indigestible substance, is likely to disagree with the stomach of invalids, when the yolk may prove perfectly harmless. Raw eggs are more wholesome than boiled, or even than those lightly poached, which are very digestible. Eggs become more difficult of digestion by being kept.—In medicine the shell is used as an antacid, its animal composition seeming to adapt it better for the stomach than chalk, the mineral form of carbonate of lime. The white is employed for clarifying liquors and sirups, which it accomplishes by entangling the small particles floating in them as it coagulates, and either rising with them to the surface, or sinking to the bottom. An astringent poultice is formed by causing it to coagulate with a piece of alum briskly stirred with it. This, under the name

of alum curd, is used as an application to the eye in some forms of ophthalmia. The white is also used as an antidote to corrosive sublimate and salts of copper. The yolk is sometimes given in jaundice, and forms an excellent diet in dyspepsia; it is preferable to the white in making emulsions.—The largest eggs of which we have any account are some found in 1850 in alluvium in Madagascar. They belong to a bird which it is supposed has recently become extinct, to which M. Saint-Hilaire has given the name of *epiornis maximus*. Two of the eggs are preserved in the French academy, and casts are to be seen in the principal museums of the world. One of them measures 13½ in. on its longest diameter, and 8½ in. on the shortest. The shell is about one eighth of an inch thick. The capacity of the egg is about 8½ quarts, six times that of the ostrich's egg, and equal to 144 hens' eggs, or 50,000 eggs of the humming bird. From some of the bones of the bird which have been preserved, its height is calculated to have been about 12 ft.

**EGG, Augustus Leopold**, an English painter, born in London, May 2, 1816, died in Algiers, March 26, 1863. He became a contributor to the academy exhibition in 1838, and was elected associate of that institution in 1848, and a member in 1860. He produced a great number of pictures illustrative of humorous scenes from Shakspeare, Le Sage, and Scott.

**EGG PLANT**, or **Vegetable Egg**, the popular name of a species of the *solanaceæ* (*solanum melongena*, Willd.), a native of North Africa. The plant grows to the height of about two feet, with a prickly stem, and with large ovate, downy, prickly leaves; flowers of a violet



Egg Plant (*Solanum melongena*).

color, of some beauty; fruit, a globose berry, crowding itself out from the downy calyx, which remains until the fruit ripens, and the deep purple color it assumes indicates its perfection. Its size depends considerably upon richness of soil and warmth of climate; in

propitious seasons it reaches several pounds' weight. It is a favorite article of food in India and other hot countries, and is much used in the United States. It is generally served up in India with sugar and wine, and is used by the French and Italians in stews and soups. Another smaller species is *S. ovigerum*, having a white fruit of the size and appearance of a fowl's egg, chiefly cultivated as an ornamental curiosity, and sometimes reared in pots to secure the ripening, as a long season seems requisite at the north. The seeds of the egg plant should be sown on a slight hot-bed in March or early in April, and the plants should be transplanted in the latter part of May, or in June, in rich, warm ground, 2½ ft. apart every way. The soil should be frequently loosened with the hoe, and drawn up around the stems. Among the Chinese, *S. Ethiopicum*, having similar fruit, furnishes an ornamental dish on great occasions.

**EGINHARD**, or **Einhard**, the secretary, confidential adviser, and biographer of Charlemagne, born in Austrasia, died at Seligenstadt about 844. He was a pupil of Alcuin, who introduced him at court. He retired after his patron's death to a country residence near Mühlheim, in the Odenwald, where he devoted himself to literary pursuits. After the death of his wife, who according to a romantic tradition was a daughter of Charlemagne, he built a convent at Seligenstadt, in the present grand duchy of Hesse, and entered it as a monk. The sarcophagus in which he and his wife were buried is still shown at the castle of Erbach, and the counts of Erbach claim to be his lineal descendants. The *Vita Caroli Magni*, by Eginhard, is one of the best biographical works of the middle ages. It has been republished by Ideler (Hamburg, 1839), and also in the second volume of Pertz's *Monumenta Germaniæ Historica*. Eginhard's *Annales Regum Francorum*, and a collection of his letters, are likewise of value to the historian.

**EGLANTINE**, an old English name for the sweet brier (*rosa rubiginosa*, Linn.), which grows plentifully in rich pastures and neglected fields. In deep soils and under favorable circumstances it is not uncommon for the old roots to send up vigorous shoots or suckers 8 or 10 ft. high, which are covered with harsh, crooked pickles. The flowers, which are for the most part borne upon the lower branches, are of a beautiful light rosy color, and full of fragrance. But the chief perfume of the plant is in the foliage, its leaves being beset with russet-colored glands, which on being slightly bruised emit a peculiar scent. The eglantine succeeds well in the garden, if ample room and a deep soil are allowed it, and in such cases it has been known to produce occasionally double flowers. It grows readily from the seeds, and sown in rows the plants have been clipped into shape to form low and ornamental hedge divisions. The species best known in the United States is supposed to be an adventitious one

from Europe, and was introduced with a co-species, also fragrant (*R. micrantha*, Smith), having smaller flowers and a different-shaped



Eglantine (*Rosa rubiginosa*).

fruit or seed vessel. Both have extended scarcely beyond the seacoast of New England.

**EGMONT**, or **Egmond**, **Lamoral**, count of, a soldier and statesman of the Netherlands, born in the castle of La Hamaide, Hainaut, in 1522, beheaded in Brussels, June 5, 1568. He inherited from his mother the title of prince of Gavre and from his father that of count of Egmont, and preferred to be known by the latter. While a boy he was a page at the court of the emperor Charles V. In his 19th year he commanded a troop of horse in the expedition against Algiers. In 1545 he married Sabina of Bavaria, sister of the elector palatine. The next year he was invested with the order of the golden fleece. In 1554 he was placed at the head of the embassy sent to England to solicit the hand of Queen Mary for Philip II. of Spain. He commanded the cavalry of the Spanish army in 1557 on the invasion of France. St. Quentin having been invested, Egmont made a brilliant charge upon the French, who came up to its relief under Montmorency, and defeated them. In 1558 the French under Marshal de Thermes invaded West Flanders, and laid waste the country. Egmont intercepted them at Gravelines on their march homeward with their booty, cut their army in pieces, and took the marshal prisoner. These victories added greatly to his reputation, and he was appointed by Philip II. stadtholder of Flanders and Artois. In this position he favored somewhat the party who were dissatisfied with the king's administration, being swayed alternately by sympathy with the popular movement and by his loyalty to the throne and devotion to the Roman Catholic church. When Margaret of Parma was appointed regent of the Netherlands in 1559,

with Granvelle as minister, Egmont and the prince of Orange were made members of the state council. Important affairs of state having been transacted by the regent and Granvelle without consultation with the council, Egmont in 1561 and 1563 joined in letters of remonstrance to the king. His opposition to Granvelle finally forced him to give up his position and leave the country. In 1565 he was sent as envoy to the court of Spain for the purpose of making the condition of the Netherlands better understood. The king made him many promises, but the government did not relent in its severity toward the provinces. On the contrary, nine inquisitors were sent thither to reestablish the inquisition. Egmont was indignant, and permitted the assembling of the nobles (1566), who declared that they would never submit to the inquisition and founded the league of the Gueux. During the iconoclastic risings which broke out soon after, Egmont obtained from the regent favorable terms for the insurgents who belonged in the provinces over which he was stadtholder. These terms having been ratified by the king, Egmont's confidence in the royal favor was strengthened. He restored the Catholics to the possession of their churches, and restrained and punished the excesses of the Protestants. He aided the royal troops in besieging Valenciennes, renewed his oath of allegiance to the regent, and finally broke off his connection with the prince of Orange and the Gueux. When Philip II. in 1567 sent the duke of Alva with a strong army to take the place of Margaret of Parma, the prince of Orange and other leaders of the people left the country; but Egmont, relying upon his interest at court, remained to look after his estates. He went out to meet the duke of Alva as he approached Brussels, and made him a present; but he was treacherously arrested, Sept. 9, together with the count of Horn. They were tried by the "council of blood," and adjudged guilty of treason. Egmont met his death with calmness, and was regarded by the people as a martyr in the cause of liberty.—One of Goethe's tragedies is founded upon his history. See Prescott's "History of Philip II.;" *Le comte d'Egmont et le comte de Horne*, by Juste (Brussels, 1862); and Motley's "Rise of the Dutch Republic."

**EGRET**, a name given to those species of white herons which have the feathers of the lower part of the back elongated and their webs disunited, reaching beyond or to the tail, at certain seasons; their forms are also more graceful than those of common herons. They belong to the old genus *ardea* (Linn.), of the order *grallatores*, since divided into many subgenera. The great American egret (*A. [herodias] egretta*, Gmel.) is about 37 in. long to end of tail, 49 to end of claws, with an extent of wings of 55 in.; bill  $4\frac{1}{2}$  in., tail  $6\frac{1}{4}$ , tarsus 6; anterior toes  $2\frac{3}{4}$ , 4, and  $3\frac{1}{8}$  in., with the claws,  $\frac{1}{2}$ ,  $\frac{3}{4}$ , and  $\frac{2}{8}$  of an inch respectively; the hind toe  $1\frac{1}{2}$ , and its claw  $1\frac{1}{8}$  in. long; weight about

$2\frac{1}{4}$  lbs.; the female is somewhat smaller. The bill is straight, tapering to an acute tip; the head compressed and oblong; neck long and slender; body compressed; feet, tarsus, and tibia long, the latter bare in its lower half. The space between bill and eye, and around the latter, is bare; the plumage is soft and blended; head not crested, though its feathers are elongated, as are those on the lower neck in front; from between the shoulders arises a tuft of long, decurved, and delicate disunited feathers, extending about 10 in. beyond the tail; the wings are moderate, and the tail short, of 12 weak feathers; the bill is bright yellow, feet and claws black, and the plumage white, in some parts slightly tinged with yellow. This elegant bird breeds from Florida to New York, and along the shores of the gulf of Mexico to Texas, and probably further; it is rarely seen in Massachusetts, and does not appear more than 50 miles inland, unless along the courses of large rivers; it generally breeds in

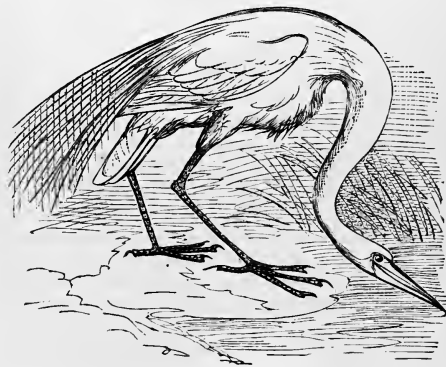

Great American Egret (*Ardea egretta*).

low marshy places, dismal swamps, and the margins of lakes and ponds; the nests are sometimes made on low bushes, and occasionally on sandy islands near the coast, but generally on high trees. The long, silky filaments of the back are hardly to be seen except in the love season, which varies from early spring to midsummer, according to latitude; both sexes possess them, and many are shot during the breeding season to obtain these feathers for ornamental purposes. It feeds by day, on small fishes, crustacea, and reptiles, which it catches in the shallows and marshes; its flight is well sustained, and its gait and movements are graceful. The nest is made of loose sticks, overhanging the water, and is used for years by the same birds, which annually repair it; the eggs, two or three in number, are  $2\frac{1}{4}$  in. long, when freshly laid smooth and pale blue, becoming afterward rough and whitish. The egret is shy and difficult to obtain, except in the breeding season; many of the young are destroyed by crows and turkey buzzards.—The European egret (*A. alba*, Gmel.) is about 3 ft. 5 in. long, with pure white plumage. Accord-

ing to Selby, the bill is black or dark brown, yellow at the base and about the nostrils, and the legs are almost black. It is common in southern Europe, but comparatively rare in the northern and central parts; the white herons of Asia are believed to be of this species. The

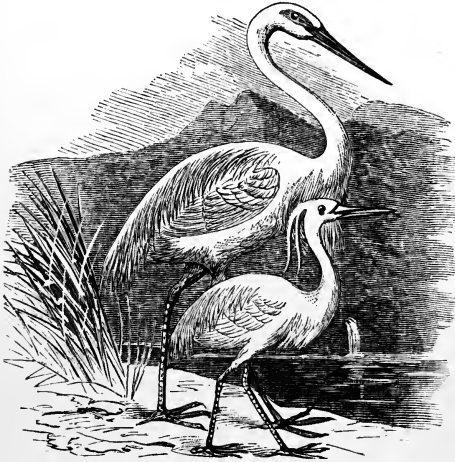

Great White Egret (*Ardea alba*), and Little Egret (*A. garzetta*).

little European egret (*A. garzetta*, Linn.) is about 22 in. long from bill to end of tail; the plumage is white; from the hind head spring two narrow feathers 4 in. long; the plumes of the back are elongated; the bill and tarsi are black; the tarsus is 4 in. long. This species is



Reddish Egret (*Ardea rufa*).

confined to the eastern hemisphere, being most abundant in southern Europe, Greece, and northern Africa; it occasionally wanders as far as England. The buff-backed egret (*A. Coromanda*, Bodd.) is about 20 in. long, the bill 2 in. and orange yellow; the plumage is white,

except the top of the head and front neck, which are buff, becoming browner as the bird grows older; it is very generally distributed over Asia. The reddish egret (*A. [demi-egretta] rufa*, Bodd.), of which Peale's egret is believed to be the young, is about 31 in. long, and 46 in extent of wings; the pale bill has a black tip; the iris is white; the feathers of the head and neck are loose and pendent, of a light reddish brown tinged with lilac, fading into brownish white at the tips; the back and wings grayish blue; long feathers of the back yellowish-tipped; pale grayish blue below. It seems never to go far from the Florida keys, except westward along the gulf of Mexico; it is a plump and graceful bird, and an easy and high flier; it rarely associates with other species; it is probably strictly marine. The nests are made by the middle of April; the eggs are three, of a pale sea-green, and are excellent food.

**EGYPT** (Gr. *Αἴγυπτος*; Lat. *Egyptus*; Heb. *Mitzraim*; Coptic, *Khami* or *Kemi*), a dependency of the Turkish empire in N. E. Africa, bounded N. by the Mediterranean, and E. by the Red sea and a direct line from Suez to El-Arish, a seaport town on the Mediterranean. Egypt proper extends S. to the first cataract of the Nile, between Asswan and Philæ, lat. 24° 5' N., and W. beyond the oases of the Libyan desert to the frontier of Barca. The area is estimated in an annual publication of the Egyptian government, *Le guide général d'Égypte* (Alexandria, 1870), at 216,000 sq. m. But the rule of the viceroy has of late also been established over an extensive region to the south, officially called Soudan, which comprises Lower Nubia, Sennaar, Dongola, Taka, Fazo-glu, Kordofan, the provinces of the White Nile, and Khartoom, and since 1865 also the coasts of the Red sea down to and inclusive of the seaport town of Massowah, lat. 15° 34' N. Inclusive of this territory, the area of the Egyptian empire was in 1872 estimated by Régný at 730,000 sq. m. Egyptian rule was recently extended by Sir Samuel Baker over a vast territory reaching south to the equator. —With the exception of a few small rivers that empty into the Red sea, the Nile is the main irrigator of the country. The White and Blue Nile unite near the city of Khartoom, forming the Nile proper, which assumes a winding N. E. course through Nubia, and receives near El-Damer the Atbara, coming from the south-east. It flows thence in a N. N. W. direction till it reaches El-Gooba, where it turns abruptly S. W., enclosing the northern point of the Bayuda desert. At Ambukol it resumes its N. N. W. course, descends the cataract near Haf-fir, turns N. N. E., and enters Egypt proper at the island of Philæ near Asswan, the ancient Syene, where it descends the famous cataracts, and flows thence unbroken by falls or rapids, and not augmented even by a rivulet, till it reaches the Mediterranean. From the cataracts the river, whose general breadth is about half a mile, runs for 600 m. through a valley

bounded by hills varying in height from 300 to 1,200 ft. The average breadth of the valley is 7 or 8 m., its greatest breadth 11 m. Anciently the whole of this valley was called Upper Egypt, but afterward the term Middle Egypt was applied to the northern part of it. About 100 m. from the sea the hills disappear, and the river enters an extensive and perfectly level alluvial plain, where, 12 m. N. of Cairo, it separates into two great streams, which continually diverge until they reach the Mediterranean by mouths about 80 m. apart, the eastern at Damietta and the western at Rosetta. This great plain is Lower Egypt. The triangular space enclosed by the two arms of the river and the sea is called the Delta, from its resemblance in shape to the Greek letter  $\Delta$ ; but the term Delta is also sometimes applied to the whole plain, or to so much of it as consists of fertile land. The greater part of the country consists of deserts, with the exception of the valley of the Nile, a few oases, and the region called Fayoom, which lies at no great distance W. of the Nile, between lat.  $29^\circ$  and  $30^\circ$ , and has a fertile area of 340 sq. m. The largest of the oases, the one most remote from the Nile, is Siwah, the ancient Ammonium, the site of the temple and oracle of Jupiter Ammon. It lies ten days' journey W. of Fayoom, and has an area of only 15 or 20 sq. m. The desert between the Nile and the Red sea is intersected by chains of mountains, whose highest summits attain an elevation of 6,000 ft.—The most noted lake of Egypt is the Birket el-Keroon, in the N. W. part of Fayoom; it is 30 m. long and from  $2\frac{1}{2}$  to  $3\frac{1}{2}$  m. broad. The remains of the famous ancient artificial lake Mœris have been identified in the E. part of Fayoom. To the north of the Birket el-Keroon, at the distance of 50 m., are the natron lakes, from which the water evaporates in the dry season, leaving the ground covered with a crust of natron or carbonate of soda. Along the seacoast of the Delta is a series of lagoons stretching for nearly 200 m., of which the principal are Lake Maryoot, the ancient Mareotis, 40 m. long, Lake Boorlos, 30 m. long, and Lake Menzaleh, 50 m. long, with an average breadth of 15 m. From a very ancient period Egypt has abounded in canals, chiefly constructed to facilitate the distribution of the water of the Nile for irrigation. The Mahmoudieh canal, 50 m. long and 100 ft. broad, was made in 1820 to accommodate the commerce between Alexandria and the Nile. Great efforts have been made during the last 20 years to render the country less dependent upon the annual inundation. The Mahmoudieh canal was connected with about 50 new canals for irrigation, which proved of some service in 1868, when the Nile failed to attain its usual height. The canal across the isthmus of Suez, to unite the Red sea with the Mediterranean, was begun in April, 1859, and opened in November, 1869. (See CANALS.)—The most striking geological feature of Egypt is the vast bed of alluvium deposited by the Nile, which covers all

Lower Egypt to a depth that probably averages 30 or 40 ft. The predominant rocks are limestone, sandstone, and granite. The great pyramids are built of limestone, and stand on a limestone plateau. This rock extends up the valley of the Nile as far as Esne, and thence to Asswan or Syene sandstone prevails, from the quarries of which most of the temples of Egypt have been built. At Asswan, at the southern extremity of the country, granite predominates, and the quarries there have chiefly furnished the materials for the obelisks and colossal statues of Egypt. The soil is of unsurpassed fertility, and its richness is annually renewed by the inundation of the Nile, which deposits upon the land a coating of mud rendering needless any other manure. In many parts ploughing is dispensed with, the seed being thrown upon the mud, and sheep, goats, or oxen turned loose in the fields to trample in the grain; though in other parts agriculture is carried on with considerable labor and care, especially where artificial irrigation can be resorted to. The rise of the Nile begins in Egypt in the latter part of June; but it is perceptible at Gondokoro, lat.  $5^\circ$  N., as early as February, at Khartoum in the latter part of March, and at Dongola in May. The inundation reaches its greatest height between Sept. 20 and 30, when it is usually 24 ft. above the low-water level. It remains at that height about 15 days, and then gradually falls, till it is at the lowest about the middle of May. It rises sometimes 30 ft., when it does great damage. If it rises less than 18 ft., a famine is the consequence in some districts not yet under artificial irrigation. The following plants are sown immediately after the inundation begins to subside, and are harvested three or four months later: wheat, barley, beans, peas, lentils, vetches, lupins, clover, flax, lettuce, hemp, coriander, poppies, tobacco, watermelons, and cucumbers. The following are raised in summer chiefly by artificial irrigation: durra, maize, onions, henna, sugar cane, cotton, coffee, indigo, and madder. Grapes are plentiful, and other fruits abound, of which the most common are dates, figs, pomegranates, apricots, peaches, oranges, lemons, citrons, bananas, mulberries, and olives. There are no forests in Egypt, and few trees of any kind except the palm, of which there are usually groves around the villages. From the absence of forests there are few wild beasts, the principal species being the wolf, fox, jackal, hyæna, wild ass, and several kinds of antelope. The chief domestic animals are camels, horses, asses, horned cattle, and sheep. The hippopotamus is no longer found in Egypt, though it is met with in the Nile above the cataracts, and the crocodile has abandoned the lower part of the river, and is becoming rare even in Upper Egypt. Among the birds are three species of vultures (one of which sometimes measures 15 ft. across the wings), eagles, falcons, hawks, buzzards, kites, crows, linnets, larks, sparrows, and the beautiful hoopoe, which is regarded with

superstitious reverence. Pigeons and various kinds of poultry are very abundant. The ostrich is found in the deserts. Among the reptiles are the cerastes and asp (*naya haye*), both deadly poisonous. Fishes abound in the Nile and in the lakes, and furnish a common and favorite article of food. Locusts occasionally invade the country and commit great ravages.—The climate of Upper Egypt differs from that of Lower Egypt, which has occasionally considerable rain, while the former is an almost totally rainless district. The average temperature of Lower Egypt ranges between 80° and 90° in summer and 50° and 60° in winter, and that of Upper Egypt between 90° and 100° in summer and 60° and 70° in winter. The most common diseases are dysentery, liver complaints, and ophthalmia, the last being very prevalent. The plague was formerly frequent and virulent, but owing to the sanitary precautions of the government it has not made its appearance since 1843. One of the most disagreeable features of the climate is the kham-sin, a hot wind from the desert which prevails for 50 days, beginning generally about May 2, and has a peculiarly oppressive and unhealthy effect.—In 1871 the country was divided into 13 provinces, 7 of which belong to Lower Egypt and 6 to Upper Egypt, Middle Egypt being at present only a geographical abstraction. The provinces of Lower Egypt E. of the Nile are: Kaliubieh, capital Kalioob; Sharkieh, capital Zagazig; Dakalieh, capital Mansoorah; in the Delta: Menoofieh, capital Menoof; Garbieh, capital Tanta; W. of the Nile: Behareh, capital Damanoor; Gizeh, capital Gizeh. The provinces of Upper Egypt, or Said, are Beni-Sooef, Minieh, Sioot, Girgeh, Kenneh, and Esne; they are named after their capital cities, with the exception of Girgeh, of which Sohag is the capital. To these has recently been added the province of the Isthmus, capital Ismailia. The cities of Cairo, Alexandria, Suez, Port Said, Damietta, Rosetta, and Kosseir are exempt from the provincial administration and placed under governors of their own. Special governors were also appointed in 1865 at Massowah and Soakin on the Red sea, who are dependent on the governor general of the southern provinces (residing in Khartoom), but are authorized to report directly to Cairo all important matters concerning the Red sea. Subordinate to the governor of a province (*mudir*) are the heads of districts (*kosafs*) and cantons (*nasirs*); the heads of single localities bear the title *sheikh el-beled*, which is also that of the magistrates of the wards of larger cities. Anciently, under its native rulers and their Persian, Greek, and Roman successors, the country was divided into districts called nomes, varying in number at different eras from 36 to 56 or 58.—A government census in 1866 officially stated the number of inhabitants at 4,848,529. In March, 1871, the population of Egypt proper amounted, according to Régnay, to 5,115,367 natives and 88,038 foreigners; total, 5,203,405;

the foreign population consisting of 34,000 Greeks, 24,000 Italians, 17,000 Frenchmen, 6,500 Austrians and Germans, and 6,000 Englishmen. With the exception of 600,000 Christians, namely, 350,000 Copts and 250,000 Franks, the inhabitants are all Mohammedans. They call themselves Arabs, though they are probably in great part descended from the ancient Egyptians. They are handsome, well made, and courteous. In northern Egypt they are of a yellowish complexion, growing darker toward the south, until the hue becomes a deep bronze. Mr. Lane speaks highly of their mental capacity, and gives them credit for uncommon quickness of apprehension and readiness of wit. They are highly religious, and are generally honest, cheerful, humane, and hospitable. The Arabs of pure blood belonging to Egypt are chiefly



Modern Egyptians.

Bedouins who dwell in tents in the desert, and number about 400,000. The native Christians, termed Copts, are the recognized descendants of the ancient inhabitants. They are generally employed as clerks and accountants in government and mercantile offices. Besides these there are about 20,000 Turks, the ruling class, and Armenians, Berbers or Nubians, and Jews.—Agriculture is the chief pursuit, and furnishes all the staples of export. The exports of Egypt amounted in 1861 to \$19,465,000; in 1865 to \$87,679,000; in 1867 to \$51,950,000; in 1869 to \$55,969,312; in 1871 to about \$52,000,000. The exceptional amount in 1865 was altogether due to the English demand for cotton, which in that year was exported from Egypt to the value of \$77,215,000, while in 1867 it fell to \$33,000,000, and in 1868 to \$29,000,000. Next to cotton, the most valuable article of export is wheat, which in 1868

was exported to the value of \$6,548,000. The export of beans, peas, lentils, barley, and dates is also increasing. The export of sugar promises to become of great importance; it rose from \$200,000 in 1867 to \$855,000 in 1868, and has considerably increased since. The imports amounted to \$26,800,000 in 1865, and to \$29,000,000 in 1867. The principal articles are timber, copper, coal, woollen, cotton, and silk goods, ivory, amber, gums, drugs, tinware, paper, oil, jewelry, sugar, glass, tobacco, spices, and coffee. The foreign commerce is chiefly with Great Britain, which receives about 75 per cent. of the Egyptian exports, and with France, Germany, and Austria. An extensive trade by means of caravans is maintained with the interior of Africa. The manufacture of firearms, and of cotton, silk, and woollen goods, is carried on extensively in establishments founded and directed by the government. The length of the state railways in Egypt in January, 1872, amounted to 649 m., 286 m. of which had double tracks. The only private railway, that from Alexandria to Ramleh, is 5 m. long. The railway from Cairo to Suez was abandoned in 1868. The telegraphic lines in operation in 1872 were 3,900 m. (560 m. being private), and had 8,300 m. of wire. Numerous sailing vessels and smaller craft ply on the Nile and the navigable canals, especially in Lower Egypt, where the principal towns are beginning to maintain regular steamboat communication. The movement of shipping in the Suez canal in 1871 was 765 vessels, of an aggregate burden of 761,410 tons. The number of arrivals at the port of Alexandria was 2,921 vessels, and at Port Said 1,275 vessels, exclusive of 87 men-of-war. There were forwarded in 1871 by the Egyptian mail 1,490,000 letters, by the Austrian 124,000, by the Italian 135,000, by the Greek 30,000.—At the head of the government stands the khedive, a vassal of the sultan of Turkey, whose office is hereditary from father to son. According to the *hatti-sherif* and *firman* of investiture of 1841, Egypt must maintain the fundamental laws of the Ottoman empire, raise taxes in the name of the sultan, issue coin with his name, and pay an annual tribute. The parliament consists of deputies elected for a period of three years. The central government is vested in the ministries of foreign affairs, finance, war, navy, public works, and the interior. The cabinet of the khedive comprises a councillor, a secretary, a seal-bearer, a treasurer, and a chief of interpreters. There are also councils of agriculture, of commerce, and for the preservation of antiquities. There are four principal courts of justice, whose seat is at Cairo: that of the chief of police, which summarily decides petty cases; that of the *cadi*, or chief judge; that of the *mufi*, or chief doctor of the law; and that of the pasha's *divan*. There is also a *cadi* in each town and village, who dispenses justice on religious transgressions, inheritance, right of succession, &c.; and each province and subdivision of the coun-

try has a *mudir* or governor who administers the criminal law. The revenue increased from £4,813,970 in 1864 to £10,571,048 in 1873, derived from taxes on land, tithes, tolls, &c., and from railways and customs duties. The total revenue in the 10 years ending Sept. 10, 1873, was £98,102,720, and the expenditure £112,561,784, of which about £6,000,000 were tribute to the sultan, £10,000,000 the cost of railways, and £16,000,000 that of the Suez canal. A new loan of £11,700,000 was contracted in 1873, making the total debt £49,000,000. The army was formerly limited to 18,000 men, but in consideration of the increase of the annual tribute from 80,000 purses to 150,000, under Saïd Pasha, permission was given to raise the army to 30,000. The navy in 1870 consisted of 12 steamers (3 yachts, 2 frigates, 2 corvettes, 4 screw gunboats, and 1 aviso).—Schools for primary instruction are connected with the mosques. The number of pupils is rapidly increasing, and in 1871 was estimated at 60,000. The university of Cairo, called *el-Ashar* (the Blossom), has students from all parts of Africa, from Turkey, and even from the Sunda islands. Education has made great progress during the reign of Ismail Pasha, especially since the establishment in 1868 of government schools in the large towns. These schools were attended in 1870 by about 4,000 pupils who received support from the government. The schools embrace both elementary and secondary education. In the secondary department the students take a three years' preparatory course, after which they are transferred to one of the special schools. These special schools are: a polytechnic school (which prepares the way for either the school of administration or the military academy), a law school, a philological and arithmetical school, a school of arts and industry, a medical school, and a naval school. In 1871 Prof. Brugsch, of the university of Göttingen, was called by the Egyptian government to Cairo, to establish there an academy for archaeology, and in particular for Egyptological studies. The periodical press is still in its infancy, and almost entirely in the hands of foreigners. There were published in 1872, in the Arabic language, an official paper and a weekly journal called *Madi el-Nil* ("Valley of the Nile"), in Cairo, and a number of French, Italian, and Greek papers in Alexandria, two of which, *L'Égypte* and *Manifesto Giornaliero*, were dailies. A press bureau is connected with the department of foreign affairs.—The history of Egypt divides itself into six great periods, each characterized by a different race of rulers: 1, that of the Pharaohs, or native kings; 2, of the Persians; 3, of the Ptolemies (Greeks); 4, of the Romans; 5, of the Arabs; 6, of the Turks. The main sources of its history under the Pharaohs are the Scriptures, the Greek writers Herodotus, Diodorus, and Eratosthenes, some fragments of the writings of Manetho, an Egyptian priest of the 3d century B. C., and the hieroglyphic inscriptions on the

monuments, that is, on the temples, tombs, and other buildings of ancient date. From works written on rolls of papyrus, found in the tombs, information has also been derived by recent Egyptologists. From the Scriptures we learn that the Hebrew patriarch Abraham went into Egypt with his family because of a famine that prevailed in Canaan. He found the country ruled by a Pharaoh, the Egyptian term for king. The date of Abraham's visit, according to Usher's chronology of the Hebrew text of the Bible, was about 1920 B. C.; according to the Septuagint, about 2550; while Bunsen fixes it at 2876. Nearly two centuries later Joseph, a descendant of Abraham, was sold into Egypt as a slave to the captain of the guards of another Pharaoh, whose prime minister or grand vizier the young Hebrew eventually became. Joseph's father, Jacob, and his family, to the number of 70, accompanied, as Bunsen conjectures, by 1,000 or 2,000 dependants, followed their fortunate kinsman into Egypt, where they settled in a district called the land of Goshen. There they remained until their numbers had multiplied into two or three millions, when under the lead of Moses they revolted and quitted Egypt to conquer and possess the neighboring land of Canaan. The date of their exodus, according to Usher, was 1491 B. C., after a sojourn in Egypt of about 210, or at most of 430 years. Bunsen assigns the date to 1320, and maintains the duration of the sojourn in Egypt to have been 1,434 years. The most recent Egyptologists generally agree that it occurred about 1300 B. C., and identify the Pharaoh of the exodus with Merneptah I. (pronounced Mernephtah in Lower Egypt), the Menephthes of Manetho, one of the last kings of the 19th dynasty. From the exodus, for several centuries, the relations between the Hebrews and the Egyptians appear to have been generally friendly, until in the 5th year of the reign of Rehoboam, about 970, Shishak, king of Egypt, conquered and plundered Jerusalem, an event the occurrence of which is attested and confirmed by the monuments.—The first of the Greek authorities upon Egypt, Herodotus, visited the country about the middle of the 5th century B. C. His knowledge of its history was derived from conversation with the priests of various cities, with whom he talked by means of interpreters. He did not himself understand the language, and his Greek guides appear to have told him many vulgar fables and legends, while what he gathered from the priests he seems to have imperfectly understood. They told him, he says, that Menes was the first king of Egypt, and was succeeded by 330 monarchs, of whom one, Nitocris, was a queen. None of them were distinguished, and none of them left any monuments worthy of note, except Mœris, the last of the 330, who constructed the artificial lake which bears his name. He was succeeded by Sesostris, who conquered Ethiopia and the greater part of Europe and Asia. His successors were

Pheron, Proteus (who was contemporary with the Trojan war), Rhampsinitus, Cheops, Cephren, and Mycerinus. The last three kings built the three great pyramids. Mycerinus was succeeded by Asychis, and Asychis by Anysis, in whose reign Egypt was conquered by the Ethiopians, who held it for 50 years under King Sabaco. At the expiration of the half century they voluntarily abandoned the country and retired to Ethiopia. The next king of Egypt was Sethos, between whom and the first king Menes, the priests told Herodotus, there had been 341 generations, a period of 11,340 years. Sethos was succeeded by 12 kings, who reigned jointly, and together built the labyrinth, which Herodotus thought surpassed all the works of the Greeks, and was even more wonderful than the pyramids themselves. After the lapse of some years, Psammetichus, one of the 12 kings, dethroned the others and made himself sole sovereign of Egypt. He was succeeded by Necho, Psammis, and Apries, the last of whom Herodotus calls the most prosperous king that ever ruled over Egypt. But in the 25th year of his reign a rebellion broke out which was headed by Amasis. Apries was defeated and put to death, and Amasis became king. Amasis was succeeded by his son Psammenitus, at the very beginning of whose reign (525) Egypt was invaded and conquered by the Persians under Cambyses. Diodorus, the next of our Greek authorities, was in Egypt about 20 B. C. Like Herodotus, he begins the line of Egyptian kings with Menes, who, he says, was succeeded by 52 monarchs, reigning 1,400 years. These were succeeded by Busiris I., and seven or eight generations later by Busiris II., who built Thebes. Later still reigned Osymandyas, and after eight more generations Uchoreus, who built Memphis, and after 15 more generations was succeeded by Myris or Mœris. Diodorus also relates the exploits of the great conqueror Sesostris, whom he calls Sesosis. He computes the whole number of native sovereigns of Egypt at 470 kings and 5 queens, and the duration of the native monarchy at 4,700 years. Eratosthenes, who died about 196 B. C., was a native of Cyrene, and was made librarian of the Alexandrian library by Ptolemy III. He wrote a work on universal chronology, fragments of which have been preserved by Syncellus and others. His computation of Egyptian chronology, so far as it goes, has been adopted by Bunsen. Manetho was high priest of Sebennytus about 280 B. C. He wrote a history of Egypt for the information of the Greeks, of which only some extracts have reached us in the works of later writers, who do not agree in their transcription of the most important part of these remains, which is a list of the dynasties and sovereigns of Egypt from the earliest period to the end of the Persian rule. But notwithstanding the occasional discrepancies produced by careless or fraudulent copyists, these "dynasties" of Manetho are



of the highest value to Egyptian history, and their general authenticity has been fully established by comparison with the monuments. There were 31 dynasties which reigned successively in Egypt, numbering upward of 300 kings, the sum of the years of whose reigns from Menes to Nectanebo II. (about 350 B. C.), the last king of the 30th dynasty, which was succeeded by the last Persian, was 3,555 years. "This succession of time," says Bunsen, "the vastest hitherto established anywhere in the old world, is now also the best authenticated. It is based upon lists of kings and their regnal years; and these lists are corroborated and elucidated by contemporary monuments up to the 4th dynasty, with slight breaks; an authentication which is as unexampled as its extent." The era of Menes, according to Bunsen, was 3643 B. C.; according to Lepsius, 3893; according to Brugsch, 4455; according to Mariette, 5004. Wilkinson remarks of Menes that the frequent occurrence of a similar name in early history, as Manes, the first king of Lydia, the Phrygian Manis, the Minos of Crete, the Indian Menu, the Thibetan Mani, the Siamese Manu, the German Mannus, and others, may seem to assign him a place among mythical beings; but that the Egyptians themselves believed him to be a real personage, and accepted the recorded events of his reign as undoubted facts. It is still in dispute among Egyptologists whether the first 17 dynasties which succeeded Menes were consecutive. It is maintained however by the latest writers, that the dynasties, with inconsiderable exceptions, were consecutive, and that the kings enumerated reigned over the whole of Egypt. In the following table we give a list of the dynasties with their capitals, the duration of their reigns, and the periods of their accession according to Mariette:

DYNASTY.	Capital.	Duration.	Date B. C.
I.	This.....	253 years.	5004
II.	".....	302 "	4751
III.	Memphis.....	214 "	4449
IV.	".....	254 "	4235
V.	".....	243 "	3951
VI.	Elephantine.....	203 "	3708
VII.	Memphis.....	70 days.	3500
VIII.	".....	142 years.	3560
IX.	Heraclopolis.....	109 "	3358
X.	".....	155 "	3249
XI.	Thebes.....	213 "	3064
XII.	".....		
XIII.	".....	453 "	2851
XIV.	Xois.....	154 "	2398
XV.	(Shepherds).....	511 "	2214
XVI.	".....		
XVII.	".....		
XVIII.	Thebes.....	241 "	1708
XIX.	".....	174 "	1462
XX.	".....	175 "	1288
XXI.	Tanis.....	130 "	1110
XXII.	Bubastis.....	170 "	980
XXIII.	Tanis.....	89 "	810
XXIV.	Sais.....	6 "	721
XXV.	(Ethiopian).....	50 "	715
XXVI.	Sais.....	133 "	665
XXVII.	(Persians).....	121 "	527
XXVIII.	Sais.....	7 "	..
XXIX.	Mendes.....	21 "	..
XXX.	Sebennytus.....	33 "	..
XXXI.	(Persians).....	8 "	..

Of the 1st dynasty, founded by Menes, no monuments exist. The second king, Teta, is mentioned in later records as having built a palace at Memphis and as the author of books on surgery. The fifth king, Hespui, was the author of sacred writings. The 2d dynasty comprised nine kings, of whom the second, Kekeu, built the pyramid at Sakkarah, the oldest monument in Egypt. He also established, it is said, the worship of some sacred animals, among others the bull Apis, who was considered to be a living manifestation of the god Ptah. The eighth king of this dynasty, Sesocris, is said to have been a giant. Some remains of sculpture made in the latter reigns of this dynasty have been found, marked by a rudeness of style showing that Egyptian art was still imperfectly formed. The 3d dynasty, whose seat was at Memphis, was founded by the earliest of Egyptian conquerors, Seker-neferke, who subdued the Lybians. Snefru, the last but one of the dynasty, subdued some of the nomadic tribes of Arabia. The pictures in the tombs of his reign show Egyptian civilization as completely organized as it was 4,000 years later. Nearly all the animals now used by man were domesticated, and the Egyptian language seems to have been completely formed. The 4th dynasty was like the 3d of Memphis, and the three great pyramids were built by three of its kings, Khufu, Shafra, and Menkara. Khufu was warlike, and won victories over the Anu, a people of northern Arabia. These kings built also the great sphinx at Gizeh, which was probably finished in the reign of Shafra, and near it a vast temple which was for ages buried in the sand of the desert, but has recently been discovered by M. Mariette. The splendor and wealth of Egypt seem to have been very great under this dynasty, but the people were oppressed and became rebellious, and the dynasty ended in a revolution about 3951 B. C. The 5th dynasty came originally from Elephantine, and numbered nine kings, whose reigns seem to have been prosperous and peaceable. Many monuments of this period remain, and from the sculptures and the paintings in the tombs it is evident that a high state of civilization existed, and that art had attained a remarkable degree of excellence. Some of the writings of this age on sheets of papyrus have been found in the tombs. The national library of France possesses a book dated in the reign of Assa-Tatkeru, the last king but one of this dynasty, written by an old man of the royal family named Ptah-hotep. It is a sort of handbook of good manners for young people, a treatise on practical morality, somewhat in the style and tone of the writings of Confucius. Filial obedience is inculcated as the basis of all good order. On the death of the last king of the 5th dynasty, a new family, of Memphian origin, came to the throne. The first king, Ati, was, it is said, after a stormy reign of 30 years, assassinated by his guards. His son and successor, Pepi Merira, was very powerful and

warlike, and has left monuments in all parts of Egypt. He conquered the Wa-Wa, a nomadic negro nation who had invaded Egypt. A second Pepi, surnamed Nefer-keru, is said to have reigned 100 years, but of this long reign little is known except that toward its end troubles broke out, the most serious and violent that had yet occurred in Egypt. The next king, Mentemhaf, was assassinated after a reign of a year. His sister Neit-aker, whom the Greek writers called Nitocris, was celebrated both for beauty and wisdom. She seized the reins of government, and for 12 years struggled energetically against the revolutionary party. At the end of that time she invited the murderers of her brother to a banquet in a subterranean gallery, and drowned them all by letting in the waters of the Nile upon them through a secret culvert. She soon after committed suicide to avoid the vengeance of their partisans. With her ended the 6th dynasty. A period of convulsion, dismemberment, and weakness succeeded, which lasted 436 years, and during which four dynasties reigned of whose history scarcely anything is known. The primitive art of Egypt attained its highest point under the 6th dynasty; but for more than four centuries afterward art and civilization seem to have been eclipsed by circumstances of which we can only conjecture that the kingdom had been subdued by foreign invaders. Memphis and Heracleopolis were the capitals during this dark period. It terminated with the 10th dynasty, or nearly 20 centuries after Menes. These 20 centuries comprise the period known among modern Egyptologists as the old empire. A new monarchy, which Egyptologists call the middle empire, began 3064 B. C. with the accession of the 11th dynasty, whose capital was Thebes. That city seems to have been founded during the period of anarchy, or at least of darkness, which followed the extinction of the 6th dynasty. From it came the six kings of the 11th dynasty, whose names were alternately Entep and Mentu-hotep, and who carried on for nearly two centuries an energetic struggle with the kings of the Delta, who had set up a separate kingdom and were perhaps foreign conquerors. The end of the struggle was the subjection of all Egypt to the Theban dynasty, one of whose monarchs is constantly designated on the monuments by the epithet "great." The 12th dynasty was also Theban, and was probably related to the 11th. All its monarchs were called Osortasen or Amenemhe, except the last, a queen named Ra-sebek-nefru. Its epoch was one of prosperity, of peace at home and of conquest abroad. Osortasen I. made great acquisitions in Arabia and in Nubia. The record of his Arabian exploits is engraved on the rocks of Sinai. Osortasen III. was also a great conqueror, and subjugated Ethiopia. Among the works of this dynasty were the labyrinth and Lake Mæris. This lake, of which some remains yet exist, was the work

of Amenemhe III., and showed a high degree of engineering skill. The art of sculpture under this dynasty was brought to a degree of perfection not subsequently surpassed. Its chief characteristics were delicacy, elegance, and harmony of proportion. The history of the 13th dynasty, which lasted from 2851 to 2398 B. C., was one long series of revolutions and internal and external troubles. Its kings were 16 in number, nearly all being named either Sevek-hotep or Nofre-hotep. No building of this dynasty remains, and the history of its kings is consequently very obscure. Toward its close, about 2400 B. C., a rival and probably a rebel line seems to have established itself at Xoïs in the Delta, where it reigned for 184 years, and constituted the 14th dynasty. This division of the nation into two hostile kingdoms doubtless facilitated and perhaps instigated the conquest of Egypt by the Hyksos or shepherd kings, who invaded the country about 2214, and soon made themselves masters of it, and ruled it for four centuries. According to Mariette and others, these Hyksos were a combination of the nomadic hordes of Arabia and Syria. The chief of them, the tribe that led the rest, were the Hittites of the Bible, who are called Khitas by the Egyptian monuments. They treated the Egyptians with great cruelty, and defaced and destroyed the temples and other monuments with savage violence. Their kings established their capital at Avaris on the northeastern frontier, where they maintained a powerful garrison. These monarchs formed the 15th, 16th, and 17th dynasties. In course of time, like the Tartars in China, they were subdued by the superior civilization of the people they had conquered, and adopted Egyptian manners and names. The last king of the 17th dynasty, whose name was Apepi, reigned 61 years, and he is considered by many authorities the Pharaoh in whose reign Joseph came into Egypt and was made governor over all the land. Soon after the conquest by the shepherds many of the Egyptians took refuge in Ethiopia, whence in time they gradually returned and founded a native kingdom at Thebes, which probably paid tribute to the shepherds, who remained directly dominant in Middle and Lower Egypt. Of these Theban kings we know the names of only two, Tiaaken and Kames. The shepherd king Apepi required his vassal Tiaaken to worship his Canaanitish god Sutekh or Set, whom he had added to the Egyptian pantheon and to whom he had built a temple. The Theban refused, and war began. The contest was long and severe. It continued through the reign of Tiaaken and of his successor Kames, and terminated in that of Ahmes, the son of Kames. The shepherds were driven at last into their great fortress Avaris, where they were besieged by the Egyptians, and were finally permitted by treaty to depart into Palestine, though a portion of them were allowed to remain and cultivate a district in the east of Lower Egypt, in much

the same way as the Israelites were allowed to settle in the land of Goshen. After the expulsion of the shepherds, King Ahmes, who had married an Ethiopian princess, turned his arms toward Nubia, which had revolted, and in a few battles completely subdued the rebels. The remainder of his reign was occupied in works of peace, in rebuilding the temples and the palaces destroyed by the shepherds. The civilization of Egypt appears to have revived immediately with great force, and trade, agriculture, and the arts to have received a fresh and vigorous expansion. The disasters and depression of four or five centuries of foreign rule seem to have been repaired in a few years. The buildings of this period are among the best in Egypt, and jewels of great richness and of incomparable workmanship have recently been found on the mummy of Queen Aah-hotep, the mother of Kames. Ahmes is considered the founder of the 18th dynasty, the greatest and most magnificent that ever reigned in Egypt (1703-1462 B. C.; according to Rawlinson much later, 1525-1324). With it opens the third historical period, known as the new empire. From this time for several centuries Egypt was one of the greatest powers of the world, and her influence was strongly felt by all surrounding nations. Her kings made great efforts to conquer Asia, from which quarter experience had shown that danger was chiefly to be apprehended. They also maintained the traditional policy, inherited from the kings of the 12th dynasty, of endeavoring to subjugate the whole valley of the Nile, which they regarded as belonging legitimately to Egypt. During the whole period of this dynasty, therefore, their armies were waging war either to the south or to the northeast. Ahmes conquered Canaan, and his successor Amen-hotep, called Amenophis by the Greeks, subdued a large part of Arabia. The next king, Thothmes I., defeated the Rotennu or Syrians near Damascus, crossed the Euphrates, and subdued Mesopotamia, which the Egyptians called Naharaina. In these wars the Egyptians first learned the use of horses, which seem previously to have been unknown to them, but which thrived exceedingly in the rich pastures of the valley of the Nile, and as well as chariots played from that time forward a very conspicuous part in their wars. Thothmes I. reigned 21 years, and was succeeded by his son Thothmes II., whose reign was short. His successor was his brother Thothmes III., a child, whose elder sister Hatasu (or Amen-set) governed for many years in his name. Her reign was brilliant, and distinguished by the conquest of Yemen or Arabia Felix, a rich and fertile country, the possession of which was always greatly coveted by the Egyptian monarchs. Among the works of Hatasu are the temple of Deir el-Bahri and the two great obelisks of Karnak, erected to the memory of her father. Under Thothmes III. Egypt attained the summit of her glory and power. Her internal affairs were well administered, and her

empire extended over the countries now called Nubia, Abyssinia, Arabia, Syria, Mesopotamia, Kurdistan, and Armenia. A great fleet, manned probably chiefly by Phœnician sailors, was created on the Mediterranean, with which Cyprus and Crete and the islands of the archipelago, the southern coasts of Greece, and probably the south of Italy, were conquered, and all northern Africa as far west as Algeria, where monuments of Thothmes III. have been found. In Egypt itself his monuments are very numerous, and are all in the best style of architecture and of the highest excellence of workmanship. He was succeeded by Amen-hotep or Amenophis II., whose reign was short, as was that of his successor Thothmes IV. The next king, Amen-hotep III., reigned at least 36 years, and was a great builder. His monuments are remarkable for their grandeur and for the perfection of their sculpture. He built the temple at Luxor and made great additions to that at Karnak, and erected the famous colossal statue at Thebes known to the Greeks and Romans under the name of Memnon. His son and successor Amen-hotep IV., whose mother, Queen Taia, was not an Egyptian, but a woman of some fair-haired, blue-eyed northern race, attempted, apparently under her influence, to reform the religion of Egypt, and to establish in place of polytheism the worship of one God. He closed the temples and effaced the images of the deities, abandoned Thebes and established his capital at a place now called Tell el-Amarna, where he erected monuments on which the ceremonies of his new worship are represented, bearing a singular resemblance to the external forms of Israelitish worship in the wilderness as described in the books of Moses. The persecution of the Israelites which led to their exodus seems to have begun shortly after this period; and it has been conjectured that the monotheism of Amen-hotep IV. may have had its origin in Hebrew influence, and that the reaction which followed his attempt at religious reformation may have caused the persecution. But the history of Egypt at this period is still very obscure, and nothing is known with certainty except that after the death of Amen-hotep IV. the kingdom became a prey to factions, whose chiefs seized the supreme power and followed each other at short intervals. Finally, however, the legitimate heir to the throne, Har-em-Hebi, the last son of Amen-hotep III., established his authority and reigned for nearly 40 years. With him ended the glorious 18th dynasty. The first Pharaoh of the 19th dynasty was Rameses I., a grandson of Har-em-Hebi. His reign was very short, and he was succeeded by Seti I., the Sethos of the Greek writers, who seems to have been not his son but his son-in-law, and to have been, strangely enough, of the shepherd race who still remained settled in the eastern part of the Delta. He was one of the greatest of the Pharaohs, and was distinguished not only as a conqueror but as a builder. He erected

the great temple of Osiris at Abydos, brought to light by recent excavations, and built also the famous "hall of columns" in the palace at Karnak. On the walls of this vast hall his warlike exploits are depicted in an immense series of magnificent sculptures. The Asiatic subjects of Egypt had revolted during the recent period of confusion, and Seti in a series of campaigns, carried as far as the mountains of Armenia, chastised and subdued them and re-established the supremacy of Egypt over western Asia. He reigned probably about 30 years, and was succeeded by his son Rameses II., whose reign lasted for 66 or 67 years. Rameses II. was the greatest builder among the Pharaohs. The two magnificent subterranean temples at Ipsambul in Nubia, the Ramesseum of Thebes, a large part of the temples of Karnak and Luxor, and the small temple at Abydos, are his works. He built also large edifices at Memphis, at Tanis, and in the Fayoom. He was also a great warrior, and made many campaigns against the tribes of the Upper Nile, who revolted at the beginning of his reign and were subdued with difficulty. While he was engaged with them in Ethiopia the subject nations of Asia deemed it a good opportunity to throw off the Egyptian yoke, and Armenia, Assyria, Mesopotamia, and Syria all revolted at once, probably by concert, and drove out the Egyptian garrisons. The Khitas or Hittites, the old enemies of Egypt, headed the rebellion, which was only subdued after a long contest, in which Rameses won high renown by his personal prowess. From these wars, and from those of his predecessors Seti and Thothmes, the Greek writers formed the legend of Sesostris, the great Egyptian conqueror, whose name was a modification of Sesu-Ra, a title given by the people for some unknown reason to Rameses during his life. The Greek accounts, which represent Sesostris as having conquered Media, Persia, Bactria, and India, are mere fables; the armies of the Pharaohs never penetrated much beyond the Tigris. Nor are the Greek legends of the internal government of Egypt under Sesostris confirmed by the real annals of Rameses, who seems to have been a cruel tyrant, and to have built his great monuments by the forced labor of prisoners of war and by oppressing his own subjects, especially the Semitic tribes who under his predecessors had settled in the Delta and were peaceably cultivating the land. Among these were the Hebrews, who had now grown very numerous, and whose increase Egyptian tyranny finally sought to check by dooming all their male children to death. The last days of this monarch show a marked decline in the arts, especially of sculpture, and also a decay of military power. Egypt was invaded by men of northern race, apparently Pelasgians, who came by sea and laid waste Lower Egypt. They finally seized the western part of the Delta and drove out the native inhabitants, and when the aged Rameses died a considerable part of his kingdom was in the

hands of these foreign barbarians. He was succeeded by his son Merneptah, who established his capital at Memphis, and at the very beginning of his reign had a contest with the northern settlers of the Delta, who sought to extend their dominion over all Egypt, but were finally defeated. A short time after this struggle is supposed to have occurred the exodus of the Israelites, which was a great blow to Egypt by depriving it of millions of industrious people, not to speak of the calamities described in the Scripture narrative. A few years later, while Merneptah still reigned, another disaster befell Egypt. A body of foreigners employed in forced labor at the granaries revolted to the number of 80,000, and called to their aid the Khitas, who invaded Egypt with such force that the king could not resist them, but retired to Upper Egypt, where he died, leaving the country full of foreign invaders and his son and heir Seti, a boy five years old, concealed for safety in Ethiopia. On the death of Merneptah a prince of the royal family usurped the throne, and succeeded in a few years in driving out the foreigners. His son Merneptah II. succeeded him, and was for a time recognized as king by Prince Seti, who received from him the title of viceroy of the southern provinces. But on arriving at manhood Seti claimed the throne and succeeded in attaining it. His reign was long, but no particulars of it are known. He died without children in 1288, and with him ended the 19th dynasty. Seti II. was succeeded by Nekht-Set, the founder of the 20th dynasty, whose reign was short and unimportant, but whose son and successor Rameses III. was one of the most eminent of the Pharaohs. He was a great soldier, though his wars were entirely defensive ones. His military genius preserved the empire from the barbarians who attacked it on every side. After his death an obscure period of a century and a half occurred, during which there were 14 or more kings named Rameses, under whom the kingdom was dismembered and again overrun by foreigners. A rival dynasty, the 21st, arose at Tanis in Lower Egypt, and after a prolonged struggle with the Pharaohs of Thebes succeeded in establishing their authority over all Egypt. One of this dynasty, whose name was Psin-en-sam, bestowed his daughter in marriage on Solomon, king of Israel. This dynasty lasted only 130 years, and was succeeded by the 22d, whose seat was at Bubastis, and whose names are almost all Assyrian, such as Nimrod, Tiglath, and Nabonasi. The first of this dynasty was Sheshonk, the Shishak of the Bible, who conquered Judah and plundered Jerusalem about 970. The duration of this dynasty was 170 years, and it was succeeded in 810 by the 23d dynasty, whose capital was Tanis. It comprised only four kings, though there were several pretenders and usurpers whose names are found on the monuments. The 24th dynasty consisted of a single king, Bokenranf, the Bocchoris of the Greeks, who reigned six years at Sais. He

was succeeded by the 25th dynasty, the founder of which was Shabaka, an Ethiopian, the Sabaco of the Greeks, the So of the Bible, who about 725 invaded Egypt with an army of Nubians and negroes and conquered it completely. He took Bokenranf prisoner, and to strike terror into the people caused him to be publicly burned alive. This Ethiopian dynasty consisted of four kings and lasted 50 years, during most of which term it was at war with the Assyrians, by whom Egypt was repeatedly invaded and conquered. The last Ethiopian king, Rot-Amen, at last voluntarily evacuated Egypt and retired to the upper Nile. Two years of anarchy followed, at the end of which Egypt was ruled for 15 years by a confederacy of 12 chiefs, one of whom, Psammetik (Psammetichus), at the end of that period dethroned his colleagues, expelled the foreigners, and made himself master of all Egypt from the cataracts to the sea. He founded the 26th dynasty, whose capital was Sais, and whose duration was 138 years. Under this dynasty Egypt, according to the Greek writers, was more prosperous than she had ever been before. She became wealthy by trade with the Greeks and other foreigners who now flocked into her ports, and who were enlisted in great numbers as mercenaries in her army. But her national spirit was corrupted; the military caste, disgusted by the favor shown to foreigners, emigrated in a body to Ethiopia; and when about 525, at the beginning of the reign of Psammetik III., the country was invaded by the warlike Persians led by Cambyses, little resistance was offered by a people who had lost all aptitude for arms, and Egypt became a Persian province governed by a satrap. The people frequently revolted and were as often subdued, but at length, about 405, they succeeded in driving out the Persians, and with the aid of Greek auxiliaries maintained their independence under a series of native monarchs, the last of whom was Nectanebo II., who was conquered and dethroned by Ochus or Artaxerxes III., in 346. Egypt continued a Persian province only till 332, when it was conquered by Alexander the Great.—Of the manners and customs, mode of life, and social condition of the ancient Egyptians, we can form a very satisfactory opinion from the representations on the monuments. It is evident from their testimony that at a very early age the Egyptians were a highly civilized people, wealthy, industrious, with a fully organized society, and great proficiency in arts, manufactures, and agriculture. The fertile soil of the Nile valley was highly cultivated. A great number of workmen were employed in weaving and dyeing rich stuffs. The arts of working in metals, of making porcelain and glass, and of preparing enamel and mastic for mosaics, had attained a high degree of perfection. The rich products of Egyptian industry were exported to the most distant countries. The progress of the Egyptians in sculpture and painting was hampered by re-

ligious restraints, which prevented their development beyond a point which was early reached. In architecture, however, they occupy perhaps the most distinguished place among the nations. No people has equalled them in the grandeur, the massiveness, or the durability of their structures. A competent authority, Fergusson, the author of the "Illustrated Handbook of Architecture," says: "Taken altogether, perhaps it may be safely asserted that the Egyptians were the most essentially a building people of all those we are acquainted with, and the most generally successful in all they attempted in this way. The Greeks, it is true, surpassed them in refinement and beauty of detail, and in the class of sculpture with which they ornamented their buildings, and the Gothic architects far excelled them in constructive cleverness; but besides these, no other style can be put in competition with them. At the same time neither Grecian nor Gothic architects understood more perfectly all the gradations of art, and the exact character that should be given to every form and every detail. They understood, also, better than any other nation, how to use sculpture in combination with architecture, and to make their colossi and avenues of sphinxes group themselves into parts of one great design, and at the same time to use historical paintings, fading by insensible degrees into hieroglyphics on the one hand, and into sculpture on the other, linking the whole together with the highest class of phonetic utterance, and with the most brilliant coloring, thus harmonizing all these arts into one great whole, unsurpassed by anything the world has seen during the 30 centuries of struggle and aspiration that have elapsed since the brilliant days of the great kingdom of the Pharaohs."—Of the religious system of the Egyptians we possess scanty information. The people were of a peculiarly devout character, and their daily lives, as well as their language, literature, art, and sciences, were strongly influenced by religion. In the earliest ages they recognized only one God, who had no beginning and would have no end; who made all things, and was not himself made. To the last the priests retained this doctrine, and taught it privately to a select few. But in the course of time it became unknown to the multitude, who began to worship the symbols under which the attributes of God were represented. The oldest temples, some of which Mariette has discovered near the pyramids, were without idols or sculptures of any kind. But this primitive simplicity soon gave way to priestly inventions by which the multitude were led into idolatry and polytheism, until at last the people worshipped many gods, and each city or district had its tutelary deity, who in that place was particularly adored, while in the rest of the country he was little regarded. The principal gods were Osiris and Isis, who were worshipped throughout Egypt; Amen, or Ammon, who like Jupiter was held to

be the "king of gods," the especial tutelar deity of Thebes; Num or Knuphis, the god of the cataracts and oases, who in later times under the Romans was called also Ammon, and considered the same as Jupiter; Sale, his wife, who corresponded to Juno; Ptah, the Memphian deity, who symbolized the creative power; the goddess Neith, worshipped at Sais, who may be compared to Minerva; Khem, who represented universal nature, and particularly the generative principle, and whose chief temples were at Coptos and at Chemmis; the goddess Pasht, whose worship prevailed at Bubastis, and who corresponded to the Artemis or Diana of Greek and Roman mythology; Maut, the maternal principle; Ra or Pthah, the sun; Seb, the earth, who was called "father of the gods;" Nepte, the sky, wife of Seb, the "mother of the gods;" Mui, the sunlight; Atnu, the darkness; Thoth, the intellect. Other noted deities were Khons, Anuke, Tafne, Savak, Mandu, Set, Horus, and Athor or Hathor. A great variety of abstract principles and even of animals and vegetables were worshipped by the multitude. To each deity an animal seems to have been held sacred, which was probably regarded as his symbolical representative. Bulls were consecrated to Osiris and cows to Athor; the sacred bull of Memphis, called Apis, being particularly venerated throughout Egypt. A hawk was the symbol of Ra, the ibis of Thoth, the crocodile of Savak, and the cat of Ptah. Of the doctrines of the Egyptian religion little is accurately known. The existence of the spirit after death was believed, and a future state of rewards and punishments inculcated, in which the good dwelt with the gods, while the wicked were consigned to fiery torment amid perpetual darkness. It was believed that after the lapse of ages the spirit would return to the body, which was therefore carefully embalmed and preserved in elaborately constructed tombs.—The government of Egypt was a monarchy, limited by strict laws and by the influence of powerful hereditary privileged classes of priests and soldiers. The priests were the ruling class. They were restricted to a single wife, and if polygamy was permitted to the rest of the people, it must have been very seldom practised. The marriage of brothers and sisters was permitted. The laws were wise and equitable, and appear to have been rigidly enforced. Murder was punished with death, adultery by bastinadoing the man and by cutting off the nose of the woman, forgery by cutting off the culprit's hands. Imprisonment for debt was not permitted, but a man could pledge to his creditors the mummies of his ancestors, and if he failed in his lifetime to redeem them, he was himself deprived of burial. Women were treated with respect, and the laws and customs seem to have been so favorable to them that their condition in Egypt was much higher than in any other nation of antiquity. The military force of Egypt

was a species of hereditary militia, which formed one of the leading classes, and in time of peace cultivated the land, of which it held a large portion. The king's guards, some few thousands in number, were the only standing army. The number of soldiers in the military class is stated by Herodotus at 410,000, which probably included all the men of that class able to bear arms. Their arms were spears and swords, and they were protected by large shields. They were distinguished for their skill as archers, and also used the sling. They do not seem to have been well supplied with cavalry, though they made much use of war chariots.—The researches of modern investigators have established the fact that the ancient Egyptians were of the Caucasian type of mankind, and not of the negro. Their language bore unmistakable affinities to the Semitic languages of western Asia, such as the Hebrew and the Arabic. Herodotus, it is true, speaks of them as black and woolly haired, but the mummies, of which immense numbers remain, prove that his words are not to be taken literally. The shape of their skulls is Asiatic, not African; and the paintings on the monuments show that they were neither black like the negro nor copper-colored like some of the Ethiopian tribes. The true negroes are distinctly represented on the monuments, and in a style of caricature which the Egyptians would not have applied to themselves. There is, however, reason to believe that the Egyptians had mixed largely with the negroes, and from the positive statements of Greek and Roman eye-witnesses there can be no doubt that they were of very dark complexion. We have no certain knowledge of the amount of population under the Pharaohs. By some of the Greek and Roman writers the number of inhabitants at the most flourishing periods is said to have been 7,000,000, a prodigious amount for so small a country, the average number to the square mile, exclusive of the desert, being twice as large as in the most densely peopled lands of modern times. Still, so great was the fertility of the country that the statement is not improbable. The cultivable land is somewhat greater in extent now than it was in antiquity, owing to the wider spread of the inundation of the Nile; and it is computed that if properly tilled it would yield more than is requisite for the food of 8,000,000 people, though without allowing any considerable surplus for exportation. Under the Pharaohs little or no corn was exported, and the land seems to have been carefully cultivated. Another statement of the Greeks and Romans, that at the height of her prosperity there were in Egypt 20,000 cities, is altogether preposterous. The country contained several large and populous cities, the most considerable of which were Thebes, Latopolis, Apollinopolis, and Syene, in Upper Egypt; Memphis, Heracleopolis, and Arsinoë, in Middle Egypt; Heliopolis, Bubastis, Leonto-

polis, Sais, Busiris, Naucratis, Mendes, Tanis, and Pelusium, in Lower Egypt.—The conquest of Egypt by Alexander the Great was much facilitated by the hatred of the natives to their Persian masters. He conciliated the priests by sacrificing to the sacred bull Apis, whom the Persians had treated with indignity; and in order to restore to the people their ancient laws and usages, he established two judgements, with jurisdiction over the whole country, and appointed two eminent Egyptians to these offices, directing also all the Greek officers to regard the customs of Egypt in administering the government. But the greatest and most permanent benefit which the Macedonian conqueror bestowed upon Egypt was the foundation of Alexandria, whose capacities to be made a port of the first class and an emporium for the commerce of the eastern Mediterranean he perceived at a glance while passing through the place on his way to visit the oracle of Ammon. The city which he ordered to be built there became in a few years one of the great capitals of the world and the chief centre of Greek civilization. Alexander effected not merely a political, but a social and intellectual revolution in Egypt, which for a thousand years after the conquest remained essentially a Greek country—the Greeks being the dominant if not the most numerous race. After the death of Alexander, 323 B. C., and the division of his empire among the Macedonian captains, Egypt became subject to Ptolemy, surnamed Soter, an able and enlightened ruler, who after a splendid reign of 38 years abdicated in favor of his son Ptolemy Philadelphus, and died two years afterward. The early part of the reign of Ptolemy Philadelphus was disturbed by civil war with his rebellious brothers, two of whom he put to death. The domestic state of Egypt was greatly improved under his administration, and Upper Egypt, which had been in a turbulent condition for half a century, was reduced to order and made safe for merchants and other travellers. The port of Berenice on the Red sea was constructed, and other cities were built or enlarged, to facilitate the trade with India, which was at that time extensive and profitable. The museum of Alexandria and its famous library, both founded by Ptolemy Soter, were under him and his son at the height of their prosperity. Demetrius Phalereus was librarian, Euclid was head of the mathematical school, and the poets Theocritus, Callimachus, and Philætas were reckoned among the ornaments of the court. The Jews at this time were numerous in Egypt, and with the king's sanction the version of the Old Testament known as the Septuagint was made from the Hebrew into the Greek. The dominions of Ptolemy Philadelphus comprised besides Egypt a considerable part of Ethiopia, together with Palestine, Cœle-Syria, Cilicia, Pamphylia, Lycia, Caria, Cyprus, and the Cyclades. His army is said to have numbered 200,000 foot and 20,000 horse, 2,000 char-

lots, 400 elephants, and a navy of 1,500 ships of war and 1,000 transports. Commerce and the arts, science and literature, directed by Greek genius and Greek energy, were carried to a height of splendor that rivalled the brightest days of the elder Pharaohs. Alexandria, the capital, was a superb city, adorned with magnificent edifices, and preëminent throughout the civilized world as a seat of learning, science, and trade. Ptolemy Philadelphus reigned like his father 38 years (285–247), and was succeeded by his son Ptolemy Euergetes, who had a brilliant and prosperous reign of 25 years. He rebuilt many of the great temples of Egypt and founded others, and his court was thronged by artists and authors. Under his profligate and tyrannical son, Ptolemy Philopator, the kingdom began to decline; and in the reign of the next king, Ptolemy Epiphanes, a minor, the king's guardians were forced to invoke the protection of the Romans against the ambitious designs of the sovereigns of Syria and Macedon, who had formed a combination against Egypt. The result of their interference was that, after a century and a half of turbulence and misrule, under eight sovereigns bearing the name of Ptolemy, the last of whom, Ptolemy XIII., reigned jointly with his sister and wife, the famous Cleopatra, Egypt was reduced to the condition of a Roman province by Augustus Cæsar, 30 B. C. It remained subject to the emperors of Rome for more than three centuries, with the short and doubtful exception of a period when it may have been held by Zenobia, queen of Palmyra. It was looked upon as the most valuable of the provinces of the empire, as the granary of Rome, upon whose harvests the idle and turbulent millions of the imperial metropolis depended for their daily bread. Its history during this long period is a record only of fruitless rebellions and of savage persecutions of the Christians, whose religion had been early introduced and made rapid progress. After the transfer of the seat of the empire to Constantinople, A. D. 330, the Christians of Egypt triumphed over the pagans, and for another period of three centuries its history presents little but theological contests, which not unfrequently broke out into civil strife. The first of these contests was the Arian controversy; Arius, who was pronounced a heretic by the council of Nice (325), being a presbyter of the church of Alexandria, while Athanasius, his orthodox opponent, was archbishop. By the emperor Constantius II. Athanasius was removed from his see and an Arian appointed in his place, while the orthodox Christians were grievously persecuted. When Julian the Apostate became emperor, the pagan mob of Alexandria rose against the Christians and murdered the Arian archbishop, and Athanasius finally regained the archbishopate. The emperor Valens appointed an Arian to succeed him, and the persecutions of the orthodox were renewed. Theodosius I. in 379 issued stringent edicts

against paganism, which still held its ground, and in Alexandria numbered among its adherents most of the learned and scientific classes and the students in the schools of philosophy. In compliance with the orders of the emperor, the pagan temples were broken into by the Christians and the statues of the deities destroyed or overthrown. The great temple of Serapis, which had been for ages the most sacred and celebrated of pagan fanes, was plundered and desecrated, and its library of 700,000 volumes despoiled by the mob. The pagans resented these outrages, and took arms in defence of their religion; but after several battles had been fought in the streets, the Christians were victorious, and the pagan leaders were driven from the city. In the reign of Theodosius II., Cyril, archbishop of Alexandria, in 414, expelled every Jew from the city. The pagans were next assailed, and one of their most popular teachers of philosophy, Hypatia, daughter of Theon the mathematician, was brutally murdered. At a later period the theological controversies of Egypt culminated in the complete separation of the Coptic or Egyptian church from the orthodox, whose bishops held a council at Chalcedon in 451, and denounced the Egyptian doctrines as heretical. The animosities generated by these contests alienated the Egyptians from the government at Constantinople, so that they made no opposition when in the reign of Heraclius, in 616, the country was overrun by the forces of the Persian king Chosroes II., who held it ten years, until the outbreak of Mohammedanism so harassed the Persians that Heraclius was enabled to recover the province, only however to lose it a few years later, in 640, when it was conquered by the Arabs, led by Amru, the general of the caliph Omar. For more than two centuries after the Mohammedan conquest Egypt remained a province of the caliphate. In 868 Ahmed the viceroy threw off his allegiance and established an independent kingdom, which lasted 37 years, when the caliphs again reduced it to subjection. After a long period of anarchy, Moez, the fourth of the Fatimite caliphs, who reigned in northern Africa, and were rivals of the caliphs of Bagdad, conquered Egypt in 970, built the city of Cairo, and made it the seat of his government. The Fatimite dynasty ruled Egypt for two centuries. The most distinguished of them was Hakem (died 1021), the prophet and messiah of the Druses, who still look for his return to earth. Adhed, the last of the Fatimites, died in 1171, and was succeeded by his vizier or prime minister, Saladin, the chivalrous and successful adversary of the crusaders. He took the title of sultan of Egypt, and at his death in 1193 was sovereign of a vast empire which his sons divided among themselves, Egypt falling to the share of Aziz. Successive invasions by the crusaders harassed Egypt for the following century, but they were all repelled by the descendants of Saladin, with signal loss to the

Christians. The last and most disastrous of these attacks was made by Louis IX. of France in 1248, who landed with a large army and the flower of the French chivalry at Damietta, but after some successes was defeated and compelled to capitulate with the loss of 30,000 men. A remarkable revolution next took place in Egypt. Saladin and his successors had organized a numerous body of guards, called Mamelukes, composed exclusively of slaves brought from the countries around the Caspian sea. They gradually acquired such power and influence that at length they deposed their lawful sovereign and made one of their own number sultan. For about 130 years these mercenaries controlled the destinies of Egypt, making and unmaking sultans at their pleasure. At length, at the close of the 14th century, the Circassians, from whom the ranks of the Mamelukes had long been largely recruited, overthrew the power of the Turkish Mamelukes and took the government into their own hands. Another century of anarchy succeeded, and in 1517 Egypt was conquered by the Ottoman sultan Selim I. and reduced to a Turkish province. Some of the Mameluke sultans were men of talent and energy, and under their rule Egypt was at times the centre of an extensive though fluctuating empire. The arts were cultivated with some success, as is shown by the mosques and tombs of these sultans at Cairo, which justly rank among the most magnificent and elegant specimens of Saracenic architecture. Under their sway Cairo became the chief seat of Mohammedan learning and intellectual cultivation. For two centuries the Turkish pashas ruled Egypt, which decayed like all the lands subjected to them. But in the 18th century the Mamelukes, who still constituted the military force of the province, gradually regained their former power to such an extent that in 1768, under the lead of their ablest and most influential chief, Ali Bey, they threw off the Turkish yoke and declared Egypt independent. But after four years Ali Bey was betrayed and poisoned, and the authority of the sultan was nominally reestablished. Confusion and civil war between the different factions of the Mamelukes continued to prevail until in 1798 the invasion of Egypt by Napoleon Bonaparte united their chiefs in self-defence. Their famous cavalry was forced to give way before the science and tactics of Europe. In the battle of the Pyramids the Mameluke army was nearly annihilated. The French conquered the whole of Egypt, and held it till 1801, when they were expelled by a British army under Generals Abercromby and Hutchinson. After the departure of the French civil war broke out afresh between the Turks and the surviving Mamelukes, which resulted in 1806 in the elevation to the post of pasha of Mehemet Ali, an Albanian adventurer who had become leader of one of the contending factions. His authority, however, was not firmly established until after a long struggle



with the Mamelukes, 500 of whom he perfidiously massacred in 1811. The dispirited survivors fled to Nubia. Mehemet Ali introduced great reforms into Egypt, in the system of administration, and in the organization of the army and navy. With the aid of European adventurers he armed and disciplined a large native force, and created a respectable fleet. Manufactures of arms, cloths, and other important articles were introduced and sedulously fostered; the commerce of Alexandria, which had dwindled almost to nothing, was revived, and the population of the city was increased tenfold during his reign. Egypt, firmly and moderately governed, enjoyed a state of peace and good order to which it had been a stranger for centuries, and attained a commanding position among the surrounding nations. He carried on a long war with the Wahabees of Arabia, finally conquering them and taking possession of their country in 1818. He next subjected Nubia to his sway. The pasha aimed at complete independence, and so great were his resources that in 1831-'3 he waged a highly successful war with the Turkish sultan, conquered Syria and a great part of Asia Minor, and would have made himself master of Constantinople had not the European powers interfered to arrest the progress of his army, and avert the overthrow of the Ottoman empire. Another war in 1839-'40, though successfully begun, ended with a considerable loss of power, owing to a new intervention. In 1848 Mehemet Ali, at the age of 80, grew imbecile, and his son Ibrahim was invested with the pashalic. Ibrahim died at the end of two months, and was succeeded by his nephew Abbas, who as governor of Cairo had been guilty of the greatest atrocities, for which Ibrahim had sent him into exile at Hedjaz as soon as he entered upon his reign. Abbas erected palaces and castles in the deserts, and withdrew to them for months at a time, without paying any attention to the duties of government. One of his first acts was to abolish the educational institutions established by his predecessors, and his next step was to dissolve the army in order to save the expense of it and increase his personal revenues. He hated Europeans, turned them out of office, and tried to drive them out of the country. The only concession he ever made was to permit an English company to build a railway between Alexandria, Cairo, and Suez. In 1852 Abbas received from the Porte an order to introduce the Tanzimat, the fundamental law of Turkey, dating from 1839, which, while granting greater liberties to the people, diminished the autocratic power of the pasha. He refused at first to obey the mandate; but finding that he was involving himself in difficulties which he would not be able to meet, he issued a firman putting the Tanzimat into immediate effect. The Porte found soon after another opportunity for humiliating the pasha. Abbas treated his relatives with great

cruelty and threatened their lives, and they fled to Constantinople and instituted proceedings against him. But a liberal use of money saved him from great molestations, and the ensuing Crimean war made it necessary for the Turkish government to keep on good terms with him. He furnished a contingent of 15,000 men and large sums of money, besides providing for the maintenance of his troops. In July, 1854, Abbas suddenly died, being assassinated, as is believed, by two Mamelukes in the service of a princess of his family whose life he had threatened. The assassination was kept a secret for nearly a week to gain time for the return of El-Hami, his son, in order to secure to him the viceroyalty, which according to the Turkish law of succession fell to Said Pasha, the fourth son of Mehemet Ali. Said Pasha was however informed of the death of Abbas in time to obtain recognition on the part of the foreign consuls and of the Turkish government. He curtailed the power of the mudirs and sheiks el-beled, instituted a new order of conscription, ordered a more equitable taxation, permitted the sale of produce to other purchasers than the government, and undertook several public works, like the cleansing of the Mahmoudieh canal and the continuation of the railway between Alexandria and Cairo to Suez. But the \$5,000,000 which he spent on the last enterprise were thrown away, as this portion of the railway failed to pay the expense of running, and was abandoned for the road subsequently built from Benha to Suez. The construction of the Suez canal is also due to him. His foreign policy was peaceful. After the close of the Crimean war the only use he was called upon to make of his large army was to check the inroads of the Bedouins, and to advance into the Nubian territories not before annexed, which he put under his protectorate. His reforms failed to bear good fruit during his lifetime, because his extravagance heaped upon the country enormous debts. He died Jan. 18, 1863, and was succeeded by his nephew Ismail Pasha. The dearth of cotton caused by the American civil war induced him to cultivate that plant upon his domains, inviting his people to follow up his experiments; the result is that Egypt has become a very important cotton market. The difficulties that beset the continuance of the excavation of the Suez canal he managed with considerable tact, and he was equally successful, by the aid of an enormous sum of money, in obtaining at Constantinople an avoidance of the Mohammedan law of succession as applied to the viceroyalty of Egypt, and the substitution of succession from father to son. In 1866 he put at the service of the Porte an army of 30,000 men to suppress the rebellion in Candia, and soon after increased voluntarily the amount of his tribute. Toward the end of the year he established a kind of parliament, consisting of 75 members, chosen without regard to religion,

for the discussion of measures that he might wish to submit for approval; but he remained as absolutely the ruler of the country as before. In the following year he obtained from the Porte several concessions on the hatt-i-sherif of 1841, which bound Egypt to an observance of the general laws of the Turkish empire, and of the treaties which it made with foreign powers. The sultan gave Ismail power to issue laws relating to the interior administration, tolls, and taxes, and to conclude treaties with other powers in regard to general transit and postal affairs. Ismail thereupon asked for the appellation of *aziz ul-Misir*, sovereign of the land of Egypt, but the sultan granted him instead the title of *khedive*, substitute or viceroy. His subsequent demands for an entirely independent legislation, and diplomatic representation at foreign courts, revealed that his aim was gradually to render himself independent of the Turkish empire. He attempted to force the Porte into granting his request by threatening to withdraw his troops from Candia, and by demanding that his tribute should be reduced to the former amount, and that it should be remitted for the next five years; he even hinted that he might take possession of Candia if his demands were not complied with. It was through the interference of the foreign powers to check his ambitious projects that a war between the sultan and his vassal was prevented. Ismail advanced in 1868 into the countries of the Upper Nile, over which he extended his sway. In the autumn of 1869 he sent out an expedition under Sir Samuel Baker to establish his rule in the lands bordering on the White Nile. In the same year he attempted to negotiate a neutralization of the Suez canal, as well as a loan, while inviting the different sovereigns to be present at the opening festivities. He received soon after an order to reduce his army to 30,000 men; to countermand the ironclads and breech-loaders which he had ordered in France, or, if that was impossible, to transfer them to the Turkish government on payment of their cost; to abstain in future from all diplomatic transactions and from making foreign loans; and to submit for inspection the annual budget of the income and expenditures of Egypt. The khedive's reply was unsatisfactory; he made no concessions, and declared that he would make loans whenever and wherever he wished. The sultan was about to send a messenger to Cairo with the ultimatum to the khedive of obedience or deposition. England and France tried to bring about a more peaceful course, but the sultan declined all interference; he was, however, induced to defer action until after the visit of the European princes at the opening of the canal. At this festivity 10,000 persons of all countries were entertained at the expense of the khedive. The empress of France, the emperor of Austria, and the crown prince of Prussia were present. Before the last guests had left Egypt a note arrived from



the sultan presenting the alternative of submission or war. Ismail had seen that he could not expect armed assistance from the European powers; he therefore issued (Dec. 9) a firman declaring his submission to the will of the sultan. But in the following year he threw another loan on the European market, saying that he offered no other guarantee than his private treasury. The sultan thereupon cut off his credit by a public announcement to the effect that the loan proposed by the khedive had not the support of the laws of the country. This and the subsequent Franco-German war obliged the khedive to abandon for a while his attempt to establish a recognized independence. He has since been busy in carrying out his other plan of getting under his control the whole country extending to Gondokoro and the coast of the Albert Nyanza, about lat. 2° S., in which he has been served by Sir Samuel Baker. The constant wars between the several rulers of Abyssinia since the English expedition afforded the khedive an opportunity to push into that country, and establish over portions of it a sort of military rule, on the pretext of protecting Egyptian trade. Through the other native territories he has drawn a military cordon, and opened roads for traffic. His intention is to transform those regions into an agricultural district; he supplies the chiefs with seed, and holds them under obligation to furnish certain quantities of produce. Thus he has made their stores of ivory, gums, hides, wax, gold, &c., more accessible; and the railways and telegraphs which he is now rapidly building through Nubia, as well as his control over the Red sea and the Suez canal, enable him to secure the wealth of these districts for the benefit of the lower provinces. These efforts of the khedive to secure the prosperity of Egypt restored to him the confidence of the sultan, and on June 8, 1873, a firman was granted which not only confirms the privileges enjoyed by his predecessors, but changes the position of Egypt from a province into an almost sovereign kingdom. The firman authorizes the khedive to make laws and internal regulations; to organize every means of defence, and without restriction to augment or diminish the number of his troops; to contract with foreign powers commercial treaties, and others regulating the position of foreigners and their intercourse with the government and the population; and to contract loans abroad in the name of the Egyptian government, with complete and entire control of the financial affairs of the country. The khedive is forbidden to make treaties bearing on political matters; he can have no agents accredited at foreign courts; the money coined in Egypt must be coined in the name of the sultan; the colors of the Egyptian army and navy must be in no way different from those of the Turkish forces; ironclad vessels must not be built without the permission of the sultan. The khedive retains the privilege of conferring military promotions up

to the rank of colonel, and civil grades to that of *rutbeh-i-sanieh* only. Finally, he is bound to remit every year, in full and without delay, to the Turkish treasury 150,000 purses of tribute.—The following is a list of some of the most important works on ancient and modern Egypt: Denon, *Voyage dans la basse et la haute Égypte* (Paris, 1802); Champollion (the younger), *L'Égypte sous les Pharaons* (Paris, 1814), and *Monuments de l'Égypte et de la Nubie* (1843); *Description de l'Égypte* (26 vols. 8vo, and 12 vols. fol. of plates, new ed., 1820-'30); Lane, "Manners and Customs of the Modern Egyptians" (2 vols., London, 1836); Russegger, *Reisen* (7 vols., Stuttgart, 1841-'50); Bunsen, *Aegyptens Stelle in der Weltgeschichte* (5 vols. 8vo, Hamburg and Gotha, 1845-'57), and more especially the second edition of the English translation, with additions by Samuel Birch (5 vols., London, 1867); Samuel Sharpe, "History of Egypt from the earliest Times to the Conquest of the Arabs" (London, 1846; new ed., 1870); Wilkinson, "Manners and Customs of the Ancient Egyptians" (3d ed., 5 vols., London, 1847), "Handbook for Travellers in Egypt" (1847), "A popular Account of the Ancient Egyptians" (2 vols., 1854), and notes and appendices to Rawlinson's "Herodotus" (1858-'9); Lepsius, *Denkmäler aus Aegypten und Aethiopien* (Leipzig, 1849 *et seq.*), *Chronologie der Aegypter* (Berlin, 1849), and *Briefe aus Aegypten und Aethiopien* (Berlin, 1852; English translation, London, 1855); Kenrick, "Ancient Egypt under the Pharaohs" (2 vols., London, 1850); Brugsch, *Reiseberichte aus Aegypten* (Leipzig, 1855), *Histoire d'Égypte des premiers temps jusqu'à nos jours* (3 vols., 1859 *et seq.*; abridged by Mariette for the use of the colleges of Egypt as *Aperçu de l'histoire d'Égypte*, Alexandria, 1864), and *Geographische Inschriften Altägyptischer Denkmäler* (Leipzig, 1857-'60); Uhlemann, *Handbuch der gesammten Aegyptischen Alterthumskunde* (4 vols., Leipzig, 1857-'8); Alfred von Kremer, *Aegypten, Forschungen über Land und Volk* (2 vols., Leipzig, 1863); Chabas, *Voyage d'un Égyptien en Syrie, Phénicie et Palestine* (Châlons, 1866); Dümichen, *Historische Inschriften* (Leipzig, 1867-'9); Ebers, *Aegypten und die Bücher Mose's* (2 vols., Leipzig, 1871-'4); and Stephan, *Das heilige Aegypten* (Leipzig, 1872). See also the travels of Savary, Sonnini, Belzoni, St. John, Harriet Martineau, J. L. Stephens, Dr. Robinson, Bayard Taylor, G. W. Curtis, W. C. Prime, &c.

**EGYPT, Language and Literature of.** Nothing is positively known of the origin and chronology of the old Egyptian language. Though very distinct, it indicates some affinity to the Semitic languages, but not as great a relationship as exists between Hebrew, Aramaic, Arabic, and Assyrian. Besides the analogy in the mode of writing, which omits many vowels and gives the words only in skeleton, there are numerous coincidences in the vocabulary. The Berber, Saho, and Galla languages, which









are considered one in origin with Semitic tongues, have also an unmistakable affinity with Egyptian: The Semitic character of the language is specially maintained by Benfey, Ernst Meir, Karl Lottner, F. Müller, De Rougé, Ebers, Brugsch, and Lepsius. Some words, however, are Indo-European, and Pott, Ewald, and Renan have placed Egyptian in that family of languages. Ewald and Renan are of late less positive, and the internal evidence seems sufficient to establish some relationship between Semitic and Egyptian. The history of the development and decay of the language has not yet been traced; only the four distinct graphic systems, hieroglyphic, hieratic, demotic, and Coptic, can safely be confined within chronological limits. The time of the development of the old and full hieroglyphic writing is unknown. It was perfectly understood and freely used in the time of the 3d and 4th dynasties, which renders it probable that the date of its discovery must be placed much earlier than 3000 B. C. The use of this writing was not confined to the sacerdotal classes, as was formerly believed on the authority of the Greeks, but it was employed by all, and for all purposes. Though shorter methods of writing were afterward devised, the hieroglyphic or pictorial representation of the language continued in use for important state documents, inscriptions, and religious compositions, and is found, accompanied by transcriptions in demotic and in Greek, down to the Roman emperor Decius, and, if Lenormant's reading is correct, as late as the usurpation of the government of Egypt by Achilles, who was put to death by Diocletian, A. D. 296. The spread of Christianity in Egypt caused a proscription of the hieroglyphics, because they are full of mythological allusions and sensual figures. The wants of a reading and writing nation led at an early period to the use of linear hieroglyphics in long documents, which subsequently developed into a cursive hand, called the hieratic. The great body of Egyptian literature has reached us through this character, the reading of which can only be determined by resolving it first into its prototype hieroglyphics. It is not possible to fix the time of the first use of hieratic writing; but from the actual preservation of several hieratic papyri of the 11th dynasty, presenting it as a perfectly distinct and well developed mode of writing, it is safe to conclude that it must have come into use long before 2000 B. C. The demotic indicates a rise of the vulgar tongue into literary use, which took place about the beginning of the 7th century B. C., when it was brought into fashion by the great social revolution in the reign of Psammetik (Psammetichus). The oldest demotic papyrus found, now in the Turin museum, dates from the 45th year of his reign, or 620 B. C. The demotic was used to transcribe hieroglyphic and hieratic papyri and inscriptions into the vulgar idiom till the 2d century



A. D., and the gradual transition from the obscure and difficult demotic to the more intelligible Coptic alphabet can be easily discerned. Demotic words were occasionally transcribed in Greek letters, pure Coptic occasionally in the demotic characters, and again demotic in Greek letters, with the sounds not found in Greek preserving their original signs, which was in reality the Coptic alphabet. Coptic is the exclusive character of the Christian Egyptian literature, and marks the last development or final decay of the Egyptian language, which became almost extinct during the last century, and made way for Arabic. (See COPTIC LANGUAGE.)—To understand the varied use of the hieroglyphic signs which make up the language, it is necessary to inquire how this system of writing came to be established. There are traces in Egyptian of a purely pictorial stage, when, as in the North American and Mexican graphic pictures, no attempt was made at recording particular words, but only ideas, which could be read in any language whatever. The great pictures on temple walls and the vignettes in the funeral rituals were probably the original text, expounded subsequently by writing proper, and ultimately preserved as illustrations. After this period of ideographs, or picturing the thing itself instead of tracing signs to suggest the name of it, the Egyptians learned in very early times to use certain objects symbolically to represent abstract ideas, actions, and relations, like goodness and anger, to adore and to rule; thus an irritated ape stood for anger, a lute for goodness, a man lifting his hands for adoration, and a whip for ruling. When no symbol could be found to convey such abstract ideas, the discovery was probably made that the sound of its name might be depicted by an object of which the name was the same or nearly the same in sound; just as in English the verb "can" might be represented by a can. This system of suggesting an idea by the picture of a different idea which accidentally had the same sound for its name, became the source of great confusion; and this led to the addition of determinative signs expressing the idea of the hieroglyphs which denoted the sound; and the subsequent desire of using consistently a selection of objects for representing names of other objects than themselves gave rise to the syllabics and alphabets. Hieroglyphs are therefore either ideographs or phonetics. The ideographs (of which there are about 900) are used in various ways: 1, directly, or representing the object itself intended to be expressed; 2, indirectly, or expressing the idea subjectively; 3, tropically, intended to convey only the quality of the object represented; 4, putting the cause for the effect, as a whip for to rule; 5, putting the effect for the cause, as a fallen man for to kill; 6, putting sacred animals and other symbols for the deities to which they belonged. The determinatives are also a subdivision of ideographs, though some pho-





netics are occasionally used as such, and form a class of about 200 hieroglyphs. They convey an idea either directly or indirectly connected with the sense of the word to which they are attached. The determinatives generally follow an ideograph, as  , a lion, where the lion is followed by the hieroglyph of a skin, which is determinative of all animals, and here shows that the lion is to be read *lion*, not simply *r*. Certain words have two determina-

tives, as , young troops, where







































































the boy expresses the special nature of the troops, and the three men the determinative conditions or kinds of men. When two determinatives were required, one sometimes preceded and the other followed the phonetic group, or occurred in the second place after a phonetic; and sometimes a phonetic was used as a determinative of a sound not afterward attached to it. Thus the determinative lion which is the phonetic for *r* or *l* is not sounded in









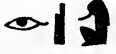

   (*shuk*), to repulse. All groups, with the exception of the verb to be, pronouns, and prepositions, are followed by a determinative. Every hieroglyphic word in fact consists of two portions: one or more hieroglyphs expressing its sound, and one hieroglyph expressing its idea. All hieroglyphs used phonetically are sounded as the original name of the object which they represent. The so-called alphabets are single syllables composed of two vowels. The syllabic phonetics represent disyllables, as  (*au*), sometimes written with its second vowel  (*u*);  (*fi*), sometimes written  " (*fi*); and trisyllables, each terminating with a vowel, as  

(*mer*), composed of  (*mu*), =  

(*mu*), and  (*ru*). Some phonetic hieroglyphs are found in the place of others in groups expressing the same idea, and are called homophones. Some alphabetic and syllabic hieroglyphs have sometimes the hieroglyph nearest approaching to their sound placed before them. Phonetics are used to express entire words, principally of an abstract nature, as the verbs to be and to have, the pronouns, prepositions, adverbs, interjections, and other words often used, as  (*neb*), a lord. They often express an entire word with only the aid of determinatives denoting the genus of the idea. Phonetics were also used to complete or indicate the meaning of certain ideographs and determinatives, and in this case are generally placed after them. In a few instances groups of ideographic hieroglyphs are used for phonetic purposes, and again some phonetics occur as determinatives of other phonetics. The form  or , which sometimes

interchange, was indifferently prefixed to certain nouns, and  to some verbs. The following is a list of alphabets in common use :













	Au		Mu		Am
	Âu		Na		Ar
	'Au		Na		As
	Ba		Nu		Âk
	Ba		Pa		Hk
	Bu		Pu		Hn
	Fi		Ra		Hr
	Zi		Ru		Km
	Hâ		Sa		Kr
	Hâ		Su		Mh
	H'a		Su		Mr
	Hu		Su		Nfr
	Iu		Ta		Nn
	Iu		Tu		Pr
	Iu		Ua		Sb
	I		Ui		Sb
	I		Ui		Ts
	K'a		Kh'a		Uh
	Ka		Khi		Ur
	K'a		Shâ		Shm
	K'a		Sha		Sh'n
	Mâ		Shi		Sh't
	Mâ		Shu		Kh'pr
	Mâ		Khnt		

	.....	<i>Amn</i> , Amen, Jupiter.
	.....	<i>Bast</i> , Bubastis, Diana.
	.....	{ <i>Hathar</i> , Athyr, Venus.
	.....	<i>Heshar</i> , Osiris.
	.....	<i>Ptah</i> , Vulcan.
	.....	{ <i>Mut</i> , wife of Amen-Ra, Thermontis.
	.....	<i>Ra</i> , the Sun.
	.....	<i>Teti</i> , Thoth, Mercury.
	.....	{ <i>Khem</i> or <i>Min</i> , Chem. (Ithyphallic god.)
	.....	<i>Assuru</i> , Assyria.
	.....	<i>Kenus</i> , Nubia.



—The Egyptian wrote with a reed and a palette, with two small oval wells of red and black ink, tracing the hieroglyphs in outline and in black, and commencing paragraphs, directions, and repetitions in red. Hieroglyphical papyri, in rolls about 10 inches wide, and often 150 feet long, present one continuous text of vertical lines, without any separation into pages. The hieroglyphs used in sculpture were generally embellished with colors, and cut from a line to an inch deep, the outline being countersunk, and the details elaborately carved on the inner surface. This protected the texts from ordinary injury and the ravages of time. Most of the hieroglyphs are only relieved by a single color, and it is often necessary to consult the polychromatic texts to determine the character of objects that are now unknown or too crudely represented. Of the colors of the monochromes, black was chiefly used during the 4th and several of the subsequent dynasties, in the 19th dynasty, and still later for sculptures in alabaster; blue, the favorite color of the Egyptians, belongs to all times, but chiefly to the 12th and 18th dynasties; green was used in the 13th, and yellow at the close of the 18th and the commencement of the 19th dynasty. The polychromes imitate, according to Egyptian notions, the color of the objects which they represent: blue, celestial objects, water, liquids, some metals, and edifices; green, trees, vegetable substances, and bronze; red, human flesh, earthenware, and the sun; yellow, light, wood, and some animals; black, hair, and several animals. The



The following are some of the principal deities and important places:

order in which the hieroglyphs are written is not uniform. When used in isolated words explanatory of persons and objects represented, they are distributed promiscuously, either in horizontal or vertical groups, or both. More careful inscriptions have them in vertical or horizontal lines, the columns separated by a broad straight line. Except in a few instances, all the animals and other objects belonging to a certain group, or a sentence, face in one direction, and are to be read in the opposite direction. The signs face generally to the right, whether written in vertical or in horizontal columns, and are read accordingly from right to left; but sometimes the reading is from left to right, although the characters face the other way. Another arrangement is to have half a sentence in vertical and the remainder in horizontal lines, and in some instances the hieroglyphs are without any arrangement whatever, distributed within the limited area of the field of a picture.—The Egyptian language retains always the verbal root of a noun unchanged, the numbers being formed by suffixes and the cases by prefixes. The singular number has the root only; the dual is expressed by repeating it if an ideograph, or by doubling the initial sign of syllables if a phonetic; and the plural by repeating three times the ideograph, syllabic, or phonetic, or by affixing three vertical bars to a masculine noun, and the half circle and three bars to a feminine. The phonetic mode of









forming the plural was to affix  (*u*), to which the three bars were usually added. The indefinite article *ua* scarcely ever occurs, and the definite article only occasionally. In the singular the masculine article is *pa* or *pui*, the feminine *ta*; in the plural, masculine or feminine, *na*, *naiu*, or *nn*, prefixed to the noun. There are only the masculine and feminine genders. Though the masculine is generally expressed by the verbal root of the noun alone, the single bar,  (*ua*, one), was sometimes affixed. The verbal root received a  (*t*), and at a later period  (*ts*), when feminine. The genitive case is formed in the singular by prefixing a noun of different signification before another, but this form is only elliptical, and during the old empire it was formed by prefixing  (*n*), or by its homophones  and  during the 20th and 21st dynasties. The genitive plural is formed at all periods by  (*nu*), following the noun. The dative is formed by  or  (*n*) when in the sense of possession, and by  (*r*) in the sense of direction. The accusative is like the nominative, and the vocative and ablative are formed by  or  (*m*), and other prepositions.



Simple adjectives are always placed after the



















noun which they qualify, compound adjectives before; and they form the masculine, feminine, and plural like the noun. The comparative is formed by adding  (*er*), the superlative by making the noun in the genitive precede, or by trebling the adjective, or by affixing  (*i*). The phonetic names of the numerals are:































-  ..... *ud*, one.
-  ..... *sen*, two.
-  ..... *khemt*, three.
-  ..... *ftua*, *ft*, four.
-  ..... *seb*, five.
-  ..... *ses*, six.
-  ..... *sefkh*, seven.
-  ..... *sesennu*, eight.
-  ..... *put*, nine.
-  ..... *kh'a*, a thousand.
-  ..... *ash*, many.

The general mode of expressing them was by repeating the vertical bar as often as required until 10; after which the characters are as follows:

- |  |   |
|--|---|
|  ..... tens.              |  ..... millions. |
|  ..... hundreds.          |  ..... billions. |
|  ..... thousands.         |   |
|  { tens of thousands.     |  ..... infinity. |
|  { hundreds of thousands. |  ..... zero.     |

Ordinals are formed by prefixing  (*meh*) or affixing  (*n*) to the cardinals. The prefix or isolated pronouns are placed at the beginning of sentences and before substantives and verbs, and are used emphatically; they are *anak*, *anuk*, *nuk*, I; *ntek*, *net*, thou; *ntef*, *su*, *ntes*, his; *nen anen*, me; *nteten*, ye; *ntesen*, *natsen*, *sen*, they. The affix pronouns either express relation or form the paradigms of verbs; they are *a*, my; *k*, masc., *t*, fem., thou; *f*, *u*, *su*, masc., *s*, *st*, fem., he, him, she, her; *n*, *nu*, we, our; *ten*, ye, your; *u*, *su*, *st*, they, them, their. When the affix pronouns are found combined with the article, the latter indicates the number and gender of

the object possessed, and the former those of the possessor. The demonstratives are *pen*, *ten*, this; *apen*, *apui*, these; *ua*, one, united with *neb*, all, to express every one; *tennu*, each; *ari*, another; *akh*, who or which, interrogative; *ma*, the relative who or which. The verb to be, when rendered by *pu*, is declaratory, and equivalent to the impersonal it is or was, following the nominative case. It is generally omitted after the pronoun *anuk*, I. When rendered by *ar*, it is often placed at the commencement of sentences, but also at the close, and either precedes or follows the nominative case. The substantive verb *au* is nearly an equivalent of the English verb to be. *Auenti* and *autu* express being or having been. Other forms of the verb to be are *au* and   (*kheper*), the latter generally in the sense of coming into existence or happening. The imperfect is formed by the introduction of  or  (*an*), between the verbal root and the nominative case, and the infinitive by prefixing *r*. The active particle *enti*, being, is often used for the relative form who is and who are, and also for it is and that; it is declined with the articles *pa*, *pui*, *ta*, *tui*, and *t* prefixed. The Egyptian verb is conjugated by prefixes, affixes, and auxiliary, abstract, or substantive verbs accompanied by prepositions. The passive form is less frequently used than the active, and chiefly in the past participle. The moods are the indicative, subjunctive, optative, imperative, and infinitive; the tenses are the same as in other languages. The present tense is formed by affixing the noun or pronoun in the nominative case to the verbal root, as *mer-a*, I love (masc.), *mer-t*, I love (fem.); *mer-k*, thou lovest (masc.), *mer-t*, thou lovest (fem.); *mer-f*, he loves; *mer-s*, she loves; *mer-neu*, we love; *mer-ten*, ye love; *mer-sen* or *su*, they love. The distinction between the perfect and the imperfect is not always strictly observed, and both tenses are formed by prefixing   (*ha*), to stand, often accompanied by the affix  (*n*) or  (*nn*), and also by placing between the auxiliary and the verb  (*her*), about, on the point of, or  (*tu*). The perfect tense can also be formed by the usual affix, as  (*ar*), to make,  (*arna*), I made, which are pronouns preceded by  ,  , or  (*n*), or by the auxiliary  (*au*), which serves also to express the future tense. The preposition  (*r*) before the verbal root and after the auxiliary is, however, the usual form of the future, which is the same as the infinitive with the verb to be. 

or  (*tu* or *ut*) forms the past participle. The simplest mode of forming the imperative is by prefixing the interjections *A!* *Oh!* or *Hai!* to the subject. *Am*, *amma*, *ma*, generally used for the optative, and *akhi*, equally used for the imperative, and the prepositions   ,  (*ar*, *r*), placed after the verb and before the subject, have the same force. The regular form of the subjunctive is hardly distinguishable from the infinitive; it has the preposition  (*n*) prefixed to the verb, and is only determined by the context. The optative mood is formed by prefixing   (*mai*). The infinitive is often given by the verbal root alone, but generally by placing the root of one verb before another, with occasionally the preposition  (*r*). A kind of gerund or participle is formed by prefixing  (*m*), or by  (*her*), in the act of, about, or  (*r*), to, in. The participle is formed by affixing the verbal root to the subject instead of prefixing it, and can be declined by adding the usual terminations; it can also be formed by prefixing  (*nt*), or by affixing  ,  , the homophones of *ta*, as   (*mer-t*), loved. The passive voice is conjugated the same as the active, but giving the verbal root the form of the past participle before the affix pronouns. The forms of *tau* or *ra* are supposed to be prefixed to verbs to give them an impulsive or causative sense, which is also effected by prefixing  or  (*s*) to nouns and verbs. The prepositions are either simple or compound. The former generally consist of one phonetic character or group; the latter of a preposition united with a noun. Both classes are prefixed to their objects, which include also verbs and sentences.  ,  , and  (*n*) are used at different periods for the genitive, dative, and ablative cases; they have the sense of by and to;  or  (*an*) indicates by means of;  (*m*) and its homophones convey the meaning of in the condition of, as, in, for, throughout, by means of, to, from, with;  (*r*), to, for, with, by, from, over, in, as far as, as, &c., and, after an adjective, than;  (*her*), or its fuller form   , signifies by means of, for, in favor of, against, beyond, in the moment of, and by;  , or the fuller form   (*kar*), stands for under, at the time of, to, at, for, and with. The compound prepositions are sometimes followed by the prefix form of the genitive. Adverbs of negation are always placed before the verb or adjective to which they belong.

(*nen*), not, and or or (bird),

(*nent*), are the principal forms of negation, combined with *put* or *sep*; they signify never.

(*m*) is used as a prohibitive negative.

Conjunctions are often omitted; (*hua*),

and, (*mak*), because, and (*khetf*),

when, are those chiefly used. Prepositions put before the verb have also the force of conjunctions: (*en*) or (*an*), for that;

(*em*), inasmuch, &c. The syntax consists chiefly in making the sentences short, rarely exceeding ten words; making the verb agree with the subject in number, but putting the verbal root, if alone, always in the singular; prefixing prepositions and interjections to the noun or verb which they govern; and putting the adverb last. The sentence consists often of two antithetical members, in which a substitution of different pronouns frequently occurs, transitions being abruptly made from different persons among themselves. The following is a portion of an inscription found in the tomb of Amenis in Beni-Hassan, dating from the 12th dynasty :



The order both of the columns and the hieroglyphs is from left to right. Verbally translated it reads as follows:

- |                  |               |             |             |  |  |
|------------------|---------------|-------------|-------------|--|--|
| 1. <i>nuk</i>    | <i>neb</i>    | <i>aamt</i> |             |  |  |
| I am             | a lord        | excellent   |             |  |  |
| 2. <i>uah</i>    | <i>mert</i>   | <i>heka</i> |             |  |  |
| very             | beloved       | ruler       |             |  |  |
| 3. <i>mer</i>    | <i>tamaf</i>  | <i>arna</i> | <i>kar</i>  |  |  |
| loving           | his country   | passed I    | for         |  |  |
| 4. <i>renpau</i> | <i>em</i>     | <i>heka</i> | <i>em</i>   |  |  |
| years            | as            | the ruler   | of          |  |  |
| 5. <i>Sih</i>    | <i>baku</i>   | <i>neb</i>  | <i>en</i>   |  |  |
| Sah              | the work      | all         | of          |  |  |
| 6. <i>sutna</i>  | <i>kheper</i> | <i>em</i>   | <i>tuta</i> |  |  |
| the palace       | was done      | by          | my hand.    |  |  |

It may be rendered thus: "I was an excellent and very beloved person, a ruler beloved in his district. I passed many years as the ruler of Sah (Speos Artemidos). All the work of the palace was done by my hand."—The history of the recovery of the Egyptian language, of which not only the vocabulary but also the characters were totally unknown, presents a

wonderful process of induction. The earlier Greeks and Romans were so little interested in the speech of other nations, and at the same time such imperfect linguists, that they left no other information concerning the language than that the Egyptians had two or three different kinds of writing, used for different purposes, and that two of them were confined to sacred uses, which is now known to be erroneous. Their other accounts of the Egyptians and their language are with few exceptions entirely wrong. They picked up stories here and there from communicative priests, and these, mixed up without discrimination, passed from one writer to another, no one caring to criticise, compare, or methodize them. The learned men who in the last century turned their attention to Egyptian writing naturally consulted the works of the ancients, and were consequently led astray. With the exception of a single passage in Clemens Alexandrinus, which is so obscure that it lends itself to many interpretations, all the ancients agreed in speaking of the hieroglyphic system as ideographic. They even gave the meaning of a few signs which are common in the inscriptions, and seemed to be well informed as to their interpretation. As the hieratic and demotic character appeared more cursive, and better suited to the transcription of long documents, they maintained that by means of them the same language was written in letters representing sounds. The writings of Kircher during the 17th, and of De Guignes and Koch during the 18th century, and later those of Zoëga, were based on the opinions of the Greeks and Romans, and failed consequently to throw light on the language. It happened that in 1799 a French engineer officer, M. Broussard, throwing up earthworks at Rosetta (Reshid), discovered a large black slab of stone, somewhat mutilated, with an inscription in hieroglyphics, in demotic, and in Greek. The victory of the English a few days later threw it into the hands of the ambassador Sir William Hamilton, who deposited it in the British museum. By this accident a text was discovered, of which the Greek version stated that it was an ascription of divine honors to one of the Ptolemies, and that the hieroglyphic and demotic versions were transcriptions of the Greek text. Though the sense of a hieroglyphic inscription was thus ascertained, the difficulty remained of determining the value and sound of each character. It was observed that at about the place corresponding to the name of Ptolemy in the Greek version, there was in the hieroglyphic inscription an oval ring enclosing a group of characters; and as a long series of sitting figures on the temple of Karnak had also such rings placed over them, apparently indicating their names or titles, it was conjectured that this ring was the sign of the proper name. An amusing account of the false conjectures made in deciphering this celebrated



inscription, based on the assumption of the Greeks that the hieroglyphic signs were purely ideographic, is given by Birch in Wilkinson's "Egyptians under the Pharaohs." The great discovery that the character was a mixed one, containing partly pictures of objects and partly signs of sounds, was announced by Champollion in a paper read at Grenoble in 1810, and soon after by Thomas Young. Champollion acknowledged that he was led to the discovery by the labors of De Sacy and Akerblad, who had shown that the Greek proper names on the Rosetta stone were transcribed phonetically in the demotic version. These results were obtained by guessing that a group occurring in almost every line was the conjunction; and that a group repeated 29 times in the demotic version corresponded to king in the Greek, where this word occurred about the same number of times; and for the words Alexander and Alexandria in the 4th and 17th lines of the Greek, were discovered two groups of equally close resemblance in the 2d and 10th lines of the demotic. Young's most important contribution was to assert the ideographic nature of many demotic signs, in opposition to the current belief that hieratic and demotic writing were entirely phonetic. It was thereupon observed that the hieratic and demotic characters were abbreviations of the fuller pictures; and Brugsch, now the highest authority on the language, shows in his *Grammaire démotique* that demotic contains at least as many ideographic signs as hieratic writing. All these conjectures were at first applied only to the characters inside the rings. But there remained the difficulty of determining the order in which the characters were written, which might be, as in Hebrew, from right to left, or, as in modern systems, from left to right. This point was soon settled by Champollion. Mr. Bankes brought a little obelisk found in the island of Philæ, which was inscribed with a dedication in Hebrew and Greek to a Ptolemy and his sister Cleopatra. This



FIG. 1.—Cleopatra.

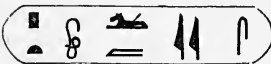

FIG. 2.—Ptolemy.

inscription was copied by Cail-liaud in 1816, and commented on by Letronne and Champollion in the French scientific journals in 1822. Figs. 1 and 2 are the hieroglyphs for

Cleopatra and Ptolemy. There was a ring identical with the ring for Ptolemy in the Rosetta stone, and another for Cleopatra. By a fortunate coincidence these names have several letters in common. Assuming from the analogy of other systems that the objects depicted signified the initial letter of their Coptic names, both groups were spelled out, and Champollion was in possession of 11 phonetic signs of the old Egyptian lan-

guage. It now became plain that in this case the signs were not syllabic, but alphabetic. Applying them to monuments which appeared to be of the Roman epoch, and attempting to decipher the royal rings upon them, Champollion found an almost complete list of the Roman emperors, each with his title, emperor, added, and this title became a clue to all similar inscriptions. Some of the opponents of Champollion suggested that the hieroglyphs were only used phonetically in order to transcribe the names of the foreign lords of Egypt; but further researches proved that well known old Egyptian kings, as Psammetichus, Shishak, and Rameses, had their names written in phonetic characters also. These discoveries made it certain that the hieroglyphic inscriptions could only be read by ascertaining the sounds of the old Egyptian language; if the writing were pictorial or symbolical, the sense could have been discovered without knowing a single sound. To discover the sounds, several learned men turned to the modern Egyptian or Coptic language, which was expressly stated by early Christian fathers to be almost the same as the demotic, though written in a different alphabet. Though the Coptic language was almost extinct, there was a school of Coptic priests at Rome during the last century, who could still speak the language of their sacred books; and from the information they possessed, together with the Coptic version of the Scriptures, a very good knowledge not only of the grammar but also of the vocabulary had been obtained. Champollion made himself master of the Coptic language, and saw that it retained more or less accurately the old Egyptian names of a large number of objects. He further analyzed grammatical forms, terminations, and inflections, and found the same close correspondence. When he was sent to Egypt to explore the ruins in person, he applied what letters he knew to groups of hieroglyphics, apparently giving the names of numerous pictures of well known objects, engraved in the tombs of Beni Hassan, and found that the Coptic furnished in almost every case a direct clue to the sound of the hieroglyphs. He thereupon easily completed his alphabet from partially read words, agreeing in sense with known names; and so the great discovery was gradually completed, sounds suggesting signs, and signs sounds, each new step verifying and correcting previous inferences as well as suggesting new ones. Two difficulties impeded the progress of the discovery. The first was to understand the proper application of the symbolical hieroglyphs, and when the same sign was to be used in the ideographic and when in the phonetic sense. Champollion concluded that the written system of 1,000 signs, used at random ideographically or phonetically, must have been a source of confusion to the Egyptians themselves, and that they must have used some means to avoid it. He therefore looked for and found indications added to the pictures, informing the

reader how to understand them. But there are some specimens of a sort of writing which Champollion left unexplained, and which he considered symbols used by the priests as a really secret character. This view has been supported by De Rougé and Lauth, but has been denied by Dümichen, who says he has been unable to find in the monuments any systematic secret writing, side by side with the usual hieroglyphics. Birch agrees with this view, and advances the theory that the 22d dynasty, of Assyrian origin, introduced phonetic signs for many ideographs, and so produced these so-called anaglyphs. Brugsch considers them merely a profusion of licenses and individual fancies, which make the interpretation a matter of great labor and ingenuity, but not impossible. The second obstacle, though greater, was readily overcome. It soon became evident that the Egyptians used different signs to signify the same sound. At the outset, when the names *Berenike* and *Aleksandros* were guessed at, it was found that there were different signs for *k* and for *s*. On comparing the several copies in the European museums of the long and elaborate book of ritual which the old Egyptians placed beside mummies in the coffin, it was found that, though they are identical in sense and character, they contain frequent variations as to single signs, and that in hieratic copies the same sign generally represents these varieties. It was clear that these were different equivalents for the same sounds, or what are called homophones. After the discovery of one of them the rest became quickly known. Lepsius has since established that the most ancient alphabet admitted very few homophones, and De Rougé says that many of them really indicate slight variations of pronunciation, which, like the various sounds of *th*, were carefully distinguished by some scribes by separate signs. After the discovery of the homophones it only required additional researches to complete the structure of which Champollion had laid the foundation and sketched the plan. Hundreds of perfectly distinct documents have since been read by the received principles of interpretation, and a consistent meaning extracted from them. Though no other corroboration was wanting, it came crowding upon the Egyptologists in the numerous confirmations of historical facts thus deciphered. Lepsius found in 1866, while making researches at Tanis, another trilingual inscription in hieroglyphics, demotic, and Greek; and the Egyptian, according to Birch, was read off and explained much easier than a fair Latin scholar could have rendered the same amount of Tacitus, and the translation produced a sense identical with the Greek version. Another test of the correctness of the principles of interpretation laid down by modern Egyptologists was offered a few years ago by Mariette, who copied from the pillars along the line of the Suez canal inscriptions set up in four languages by Darius I.,

king of Persia, describing how he had undertaken the cutting of the canal, but stopped it when almost completed because he was persuaded that the levels of the Red sea and the Mediterranean varied, and that Egypt would be inundated by opening the canal. The inscription found on several stone pillars was written in hieroglyphics and in the three kinds of cuneiform characters, and it was found that the Persian and Assyrian versions correspond in sense to the hieroglyphic as now interpreted, adding, however, many details intended for the special edification of the Egyptian subjects of the great king. Champollion's system of interpreting hieroglyphics encountered great opposition at every step of his discovery. Among his most prominent opponents were Klaproth, Palin, Janelli, Williams, Secchi, Seyffarth, and Uhlemann, every one of whom proposed some method of decipherment as much at variance with the methods of the others as with Champollion's; with the exception of Uhlemann, who adopted Seyffarth's suggestions. The chief value of their writings consisted in stimulating new researches to correct or establish the rules laid down by Champollion and his followers. The most eminent among these are Sylvestre de Sacy, Niebuhr, Humboldt, Lepsius, Bunsen, Rosellini, Leemans, Wilkinson, Hincks, Brugsch, Birch, De Rougé, Chabas, Le Page Renouf, Lauth, Dümichen, Goodwin, Czermak, Devéria, Eisenlohr, Ebers, Mariette, and Maspero. The researches on the hieratic writing were of necessity closely linked to the study of hieroglyphics. The decipherment of the demotic writing was specially studied by De Sacy, Akerblad, and Young. It was further elucidated by Champollion, Tattam, Salvolini, Lepsius, De Sauley, Leemans, and Maspero, and was finally treated by Brugsch in a separate grammar and a hieroglyphic-demotic dictionary.—LITERATURE. The literature of Egypt presents a remarkable exception to the literatures of other countries. It contains no signs of a gradual development of different species of composition at different epochs. The characters were changed, and the language underwent some modifications, but the literature remained in its principal features the same. Novels or works of amusement predominated in the great epoch of the Rameses, and historical accounts of Egypt under the Ptolemies, just as homilies, church rituals, and other Christian literature invaded Egyptian in its Coptic stage; but the same type and general style appear in every epoch. There is therefore no need of a chronological sketch of Egyptian literature. Its materials are scanty, and many periods of Egyptian history are as yet complete literary blanks. Another misfortune is that even the scanty documents recently obtained are not all accessible; many of them are lying unread in private collections. The magnificent collections of Mr. Harris of Alexandria, and of Mr. Smith, an American resident at Luxor, and doubtless many others,

are yet almost entirely unknown.—The religious is the most important branch of the Egyptian literature that has come down to us. At first sight it seems to proclaim the Egyptians the most polytheistic of men, but a more careful examination leads to the supposition that the various gods were only intended to bring out in symbol and in allegory the various qualities and manifestations of one great God, uncreate, eternal, and omnipotent. Egyptologists strongly combat the commonly received opinion that the doctrine of one God was the belief of the learned only, and that the Egyptian ritual was intended for the vulgar. The most prominent of the theological treatises is the "Book of the Dead," also called the "Funeral Ritual." The earliest known copy is in hieratic writing of the oldest type, and was found in the tomb of a queen of the 11th dynasty, which can hardly be placed later than 3000 B. C. The sense of certain chapters had already become obscure to the writers, who add many notes and rubrics, and sometimes another reading; thus it contains another version of the 64th chapter, ascribed to King Menkera of the 4th dynasty. The latest copy is of the 2d century A. D., and is a demotic papyrus written in pure Coptic. It consists, in its complete state, of 166 chapters, many of which were added in the days of the new empire, or about 1600 B. C., and perhaps as late as the time of Psammetik. The main body of the work is uniform throughout, and gives a mystical account of the adventures of the soul after death, and directions how by the use of theological knowledge, as being able to recite the names and titles of innumerable gods, the soul could reach the hall of Osiris. Here it was to be judged by Osiris and the 42 assessors, who took cognizance of the 42 mortal sins. It was probably from some confused report of this chapter of the ritual that Diodorus was led to state, what is often repeated in modern books, that the Egyptians held trial over their dead before burial. The soul was sent, after a successful examination, to the abode of the sun, to live in blessedness. Almost every museum in Europe has specimens of the ritual, and many have published facsimiles of it. A complete translation, by Dr. Birch, may be found in the 5th volume of the 2d edition of Bunsen's "Egypt's Place in Universal History" (London, 1867). The best editions of the whole text are Lepsius's *Todtenbuch* (Leipzig, 1842), from a Turin copy in linear hieroglyphics; De Rougé's *Rituel funéraire* (Paris, 1861-'5), in hieratic; and a collection of the most important texts in Lepsius's *Älteste Texte des altägyptischen Todtenbuchs* (Berlin, 1867). The preparation of these books of the dead seems to have been a regular trade with the Egyptian priests. They were written and illustrated in various styles, proportioned to the rank of the deceased or to the price which his relatives chose to pay, and they were placed in the coffin with the dead. As the books were to be sealed up, and

not to be read, or seen again by the relatives, they are often written with the greatest carelessness, and are full of omissions and gross faults in orthography. They seem to have been kept ready made, for the name of the deceased appears in different ink and handwriting from the rest of the book, and appears to have been inserted in a blank left for the purpose. The only other kind of composition which can be strictly classed as theological are the treatises describing the metamorphoses of the gods, and the lamentations of Isis, found in the tombs of priests and priestesses; but these books are so replete with allegories that it is almost impossible to discover their meaning. To this class belong also the myths in the Ptolemaic temples, and it is believed that when the immense profusion of pictures found at Edfoo, Esne, Denderah, and other such temples are collected and deciphered, the obscurities of the ritual will be greatly diminished. They explain such myths as that of the winged disk, or the adventures of Horus in avenging his father Osiris, and possess occasional historical allusions of great value. Some of these texts are given in Brugsch's *Die geflügelte Sonnenscheibe* (Berlin, 1870), and Naville's *Textes relatifs au mythe d'Horus* (Paris, 1870). The devotional treatises mainly consist of hymns, some of which are addressed to the sun or to the god of Egypt considered as such, and abound in lofty and pure sentiment. Translations of such hymns are scattered among the archaeological, philological, and oriental reviews; some may be found in Chabas's *Papyrus magique Harris* (Châlons, 1861) and Maspero's *Hymne au Nile* (Paris, 1868). The ethical treatises are in part in the form of regular moral essays, either in a connected discourse or in disjointed proverbs; partly in an epistolary form, under the garb of a private letter from a teacher to his pupil, but evidently intended for general use; and also in the form of dialogue. The oldest hieratic book which we possess is the moral treatise of Prince Ptah-hotep, and the copy of it, called the Prisse papyrus, may have been prepared as late as the 11th dynasty; but the author speaks of himself as having reached a ripe old age under Assa, the last king of the 15th dynasty. The collection of proverbs in the Leyden papyri, which is of the Ramesid era, and the instructions of a demotic papyrus in the Paris library, dating from the Ptolemies, differ in no fundamental point from the ancient treatise, and do not even show a development. They enumerate and enjoy the same private and social qualities which are now thought to make a man respectable. Fragments of Ptah-hotep's moral discourse have been translated by Dümichen in *Der Aegyptische Felsentempel von Abu-Simbel* (Berlin, 1869), and by Lauth in his *Moses der Ebräer* (Munich, 1868). The proverbial precepts of the demotic treatises are given in the *Recueil de travaux relatifs à la philologie égyptienne et assyrienne* (Paris, 1870). The moral philosophy of one of the Leyden papyri speaks in para-

bles, and explains its truths by the aid of metaphors from common life. A translation of it is given in Leemans's *Monuments du musée d'antiquités des Pays-Bas* (Leyden, 1839-'64). The instructions conveyed in letters mostly concern particular cases, and recommend special professions; and being all the compositions of literary men, they naturally laud their own occupation as the highest. The Sallier papyri in the British museum furnish the best specimens of these epistolary treatises. There are translations of them by Prof. Goodwin in the "Cambridge Essays" for 1858.—The magical literature has come down to us in many specimens. They are preserved in the papyrus of Mr. Harris, which Chabas has translated, and in the Ramesid papyri and demotic fragments of the Leyden and Paris museums. The principles adopted in the magic ceremonies of the Egyptians were uniform. There is first a mention of a mythological event, generally relating to some of the conflicts between Osiris and Set, or the good and evil powers in nature; secondly, the conjurer identifies himself with a deity whose powers and attributes he assumes by means of incantation; lastly, injunctions and threats against the objects to be conjured. People in almost every condition of life appear to have sought assistance from magic, and numerous little rolls of papyrus inscribed with magic formulas have been found, which were used as amulets to protect the wearer from sickness or death.—The medical papyri, or prescriptions of the old Egyptians, are described by Brugsch in his *Ueber die medizinischen Kenntnisse der alten Aegypter* (1853), and in his *Notice raisonnée d'un traité médical, &c.* (Leipsic, 1863), reprinted from the second volume of his *Recueil de monuments* (Leipsic, 1859); by Chabas in his *Mélanges égyptologiques* (vol. i.); and by Birch in Lepsius's *Zeitschrift* for 1871. The most remarkable is the papyrus of Berlin, which states that it was discovered rolled up in a case, under the feet of an Anubis in the town of Sekhem, in the days of Tet (or Thoth), after whose death it was transmitted to King Sent, and was then restored to the feet of the statue. King Sent belonged to the 2d dynasty, and if the treatise was old in his day, Manetho's statement that the second king of Egypt, the successor of Menes, composed works on anatomy, is more than probable. These data remove the origin of medicine among the Egyptians to a time long previous to 3000 B. C. The contents of this papyrus give a kind of anatomy of the human body, and a number of remedies, which were generally to be taken internally, and consisted of carefully proportioned prescriptions, in which the milk of various animals, honey, salt, and vinegar play a prominent part. There are also directions for the application of raw flesh, lard, and ammonia, and prescriptions of draughts, unguents, and injections. Noticeable is the entire absence of charms and superstitious observances in administering medicines,

and the attempts at rational treatment far surpass the medical literature of the early Greeks. Later documents are of inferior scientific value, and they contain a great deal of magic and incantation, although the remedies are prescribed for the most part separately from them. But the documents are so few that we may have recovered accidentally a higher order of treatise from the earlier, and inferior kinds from the later period of Egyptian history. The demotic papyrus repeats the same technical terms for remedies, but shows a small proportion of honest prescriptions; and love philtres, which turn the love of women toward their husbands and lovers, and not the opposite, as generally told by classical authors, play a great part in it. The Coptic period furnishes a fragment treating of skin diseases, one of the most prevalent and permanent plagues of Egypt. It is a small portion of a large work, as the prescriptions preserved are called the 185th chapter; they consist of potions, baths, and unguents.—The scientific treatises show, especially in a document belonging to the old empire, and now preserved in the Berlin museum, that the Egyptians were acquainted with the true motion of the planets, including that of the earth. Among the Rhind papyri in the British museum, there is one called the geometric papyrus, of which Mr. Birch has published a short description in Lepsius's *Zeitschrift* for 1868. The age is given as the 20th dynasty, or about 1100 B. C. The treatise proceeds in regular propositions, stating the questions with "Suppose," and the answers with "Therefore" or "It follows." It is chiefly concerned with mensuration, the measuring of fields, and the estimating of the solid contents of pyramids; its title reads, "Principle of arriving at the Knowledge of Quantities, and of solving all Secrets which are in the Nature of Things." The area to be measured is divided into parallelograms or isosceles triangles, and the lengths of the sides are generally given in the statement of the question.—Epistolary correspondence is, like the solar hymns, one of the best known and most perfectly understood branches of Egyptian literature. From the Ramesid era, which was undoubtedly the most literary of all, we have about 80 letters on various subjects, from different scribes, of whom the names of 13 are preserved, and they are mere specimens of style and illustrations of manners. There are about 20 letters in different papyri of the Leyden collection, but as some of them seem to have been prepared for transmission, they cannot well be considered as specimens of literature. The most important collection is that in the Sallier and Anastasi papyri of the British museum, and consists of 58 letters, of which a few are duplicates. The collection was made by three scribes, about the time of the Exodus, and their names are Pentaur, Pinebsa, and Enna.—The fictitious writing of the ancient Egyptians is represented by two valuable and tolerably com-

plete relics: "The Tale of the Two Brothers," contained in the document known as the D'Orbigny papyrus of the British museum, and first described by De Rougé, and "The Romance of Setna," recently discovered in the tomb of a Coptic monk by Brugsch, who furnished a translation of it in the *Revue archéologique* for 1867. The former was written by the scribe Enna, and evidently intended for the amusement or instruction of one of the royal princes, whose name is mentioned in the last chapter. One of the most striking features of this romance is the low moral tone of the women introduced, and the blunt realism exhibited in their life and language. Other documents of the same period show that the Egyptian ladies held a far higher position than is here implied. Our demotic copy of the "Romance of Setna" was written in the 2d or 3d century B. C. The story turns upon the danger of acquiring possession of the sacred books without a clear right and great precaution; but the opening of the story and its date and superscription are missing. The epics and biographical sketches, excluding here the sepulchral monuments, which are of greater value to history than to literature, consist of a number of narrations of personal adventure in war or travel, and are distinguished by special efforts at the graces of style. Prominent among them is the epic of Pentaur, on the achievements of Rameses II. in his war against the Kheta. This poem, which has been called the Egyptian Iliad, was very popular and widely known, and several copies of it are in existence. Considering that it is several centuries older than the Greek Iliad, it deserves admiration for the rapid narration of the antecedents and consequents of the great scene in order to preserve it as the most prominent and central picture of the poem. Translations of it are given by Prof. Goodwin in the "Cambridge Essays," and by De Rougé in the *Recueil de travaux relatifs à la philologie égyptienne*. The biographical sketch of Mohar has been called the Odyssey, by way of contrast with the preceding. The author gives an account of the journey of Mohar, evidently a high official, through Syria and Palestine, gathered from the correspondence or diary which the latter had sent to him. This papyrus, in the Anastasi collection of the British museum, has been translated by Chabas, under the title of *Voyage d'un Égyptien* (Berlin, 1866), by Goodwin, and by Lauth in the appendix of his book *Moses der Ébräer*; and the last named author endeavors to establish that the person spoken of in the document was Moses himself, while Brugsch and De Rougé believe that the journey is not real, but only intended to furnish an entertaining description of the lands spoken of. The satirical writings and beast fables of the Egyptians caricature the foibles of all classes, and do not even spare the sacred person of the king. They are often illustrated with satirical pictures in mimicry of the Pharaohs and their

courts. One such, known as the satirical papyrus of Turin, has been published with the caricatures in Lepsius's *Auswahl*. — Besides these numerous specimens of a strictly literary nature, a large amount of judicial documents, as petitions, processes at law, judgments, decrees, and treaties, has also been recovered. In the chronological documents, history is computed after the manner of early nations by a list of kings and priests; and without dwelling upon their historical value, we owe to them the whole of our knowledge of the Egyptian language, as the decipherment of some proper names mentioned in them furnished the first clue to the reading of hieroglyphics.

**EHNINGER, John Whetton**, an American artist, born in New York, July 22, 1827. He graduated at Columbia college in 1847, and in 1848-'9 he was a pupil of Couture in Paris. His first oil painting, "Peter Stuyvesant" (1850), the subject of which was taken from "Knickerbocker's History of New York," was engraved by the American art union. Among his best works are "Love me, love my Horse," "The Sword," "The Foray," the landscape of which is by Mignot, "Lady Jane Grey," and *Ars Celare Artem*. He has also produced a series of etchings illustrating Hood's "Bridge of Sighs," published in 1849, another on subjects from Irving's story of "Dolph Heylinger" (1850), eight illustrations of Longfellow's "Miles Standish" (1858), and various other works of the kind.

**EHRENBERG, Christian Gottfried**, a German naturalist, born at Delitzsch, April 19, 1795. He was educated at Leipsic and Berlin. In 1818 he published *Sylva Mycologica Berolinenses*, in which he described 62 new species of cryptogamous plants. In 1820 he visited Egypt, Nubia, and Arabia, at the expense of the Berlin academy of sciences, and continued his scientific explorations in those countries for six years. On his return to Berlin he was appointed extraordinary professor of medicine. In 1829 he accompanied Humboldt to the Ural mountains and central Asia. In 1842 he was elected permanent secretary of the academy, and in 1847 was appointed to a regular professorship. The scientific results of his observations in Africa are contained in *Symbola physica Mammalium, Avium, Insectorum et Animalium Evertibratorum* (Berlin, 1828-'33); *Die Korallenthierse des Rothen Meeres* (1834); and *Die Akalephen des Rothen Meeres* (1836). He engaged in the investigation of infusoria, and arrived at results of the greatest value, which were presented in various publications, the most complete of which is *Die Infusions-thierchen als vollkommene Organismen* (with 64 plates, Leipsic, 1838). He discovered fossil infusoria, showed the similarity of their phenomena in different parts of the world, and published on this subject *Die fossilen Infusorien und die lebendige Dummerde* (1837); *Die Bildung des europäischen, libyschen und wralischen Kreidfelsens und Kreidemergels aus*

*mikroskopischen Organismen* (1839); and especially *Mikrogeologie* (1854). For some account of his discoveries and classification, see ANIMALCULES. Among his works on other subjects is *Ueber die naturwissenschaftlich und medicinisch völlig unbegründete Furcht vor körperlicher Entkräftung der Völker durch die fortschreitende Geistesentwicklung* (Berlin, 1842). His latest publication is *Mikrogeologische Studien als Zusammenfassung seiner Beobachtungen des kleinsten Lebens der Meeres-tiefgründe aller Zonen und über dessen geologischen Einfluss* (Berlin, 1872).

**EHRENBREITSTEIN** (*i. e.*, the broad stone of honor), a town of Prussia, on the right bank of the Rhine, opposite Coblenz, with which it is connected by bridges; pop. in 1871, 2,504, exclusive of the garrison. It is situated at the foot of a rocky height, upon which is the fortress. The fortress of Ehrenbreitstein was probably founded by the Romans under the



Ehrenbreitstein.

emperor Julian, was rebuilt in the 12th century by Hermann, archbishop of Treves, and became of great strategical importance during the thirty years' war. The French under Marshal Boufflers, aided by Vauban, in vain besieged it in 1688. They assailed it again at the end of the following century, but gained possession of it (January, 1799) only after a siege of 14 months, and after reducing the garrison to starvation. In 1801 they blew up its defences, but the fortress was subsequently rebuilt by Prussia. The works will lodge 100,000 men, yet a garrison of 5,000 is deemed sufficient to defend them. The magazines are capable of containing provisions for 8,000 men for ten years. The escarped rocks and steep slopes on three sides of the fortress seem impregnable. The platform on the top of the rock serves as a parade ground, and covers vast arched cisterns capable of holding a three years' supply of water, which is obtained from springs without the walls.

**EIBENSTOCK**, a town of Saxony, near the right bank of the Mulde, 16 m. S. E. of Zwickau; pop. in 1871, 6,362. It has manufactories of muslin, lace, chemicals, and tobacco; and in the vicinity are several tin mines, to which the town owed its foundation in the 12th century.

**EICHENDORFF, Joseph Karl Benedikt**, baron, a German author, born near Ratibor, Upper Silesia, Dec. 10, 1788, died at Neisse, Nov. 26, 1857. He fought as a volunteer in the last campaigns against Napoleon I., and held various offices under the Prussian government, retiring in 1844. He was a representative of the romantic school, wrote many fine poems, novels, and plays, and translated Don Juan Manuel's *El conde de Lucanor* (Berlin, 1824) and Calderon's religious plays (2 vols., Stuttgart, 1846-'55). Among his critico-historical writings are *Der deutsche Roman des 18. Jahrhunderts in seinem Verhältnisse zum Christenthum* (1851), and *Geschichte der poetischen Literatur Deutschlands* (1856). The 4th edition of his poetry and of his most popular novel, *Aus dem Leben eines Taugenichts*, appeared in Berlin in 1856.

**EICHHORN, Johann Gottfried**, a German scholar, born at Dörenzimmern, in the principality of Hohenlohe-Oehringen, Oct. 16, 1752, died in Göttingen, June 25, 1827. He studied theology at Göttingen, in 1775 was elected professor of oriental languages in the university of Jena, and in 1788 was called to the same office at Göttingen, where he taught till near his death. He first proved the extent of his learning by treatises on the commerce of the East Indies prior to the time of Mohammed, and on the ancient history of the Arabs. At Göttingen he devoted himself especially to Biblical criticism, and published *Repertorium für biblische und morgenländische Literatur* (18 vols., Leipsic, 1777-'86), and the *Allgemeine Bibliothek der biblischen Literatur* (10 vols., 1787-1801), which he prepared in connection with other learned men. He was especially influential in founding the interpretation of the Scriptures on a knowledge of Biblical antiquity and oriental modes of thought by his introductions to the Old and New Testaments, and his works on the Hebrew prophets and on the Apocalypse, besides many valuable papers in periodical works. Having conceived the plan of a full history of all branches of intellectual culture in Europe since the revival of letters, he associated him-

self with several scholars, and composed, as an introduction, the *Geschichte der Literatur von ihrem Anfange bis auf die neuesten Zeiten* (6 vols., Göttingen, 1805-'12). Among his other writings are *Urgeschichte* (edited by Gabler, 2 vols., 1790-'93), in which he examined the Mosaic records of the creation and fall; and works on the French revolution (1797), on ancient history (2 vols., 1811-'13), and on the history of the last three centuries (6 vols., 3d ed., 1817-'18).—His son KARL FRIEDRICH, born Nov. 20, 1781, professor of law at Berlin and elsewhere, Prussian state councillor, &c., was the author of works on German law and history, and edited with Savigny and others from 1815 to 1838 the *Zeitschrift für geschichtliche Rechtswissenschaft*. He died July 4, 1854.

**EICHSTÄDT**, a town of Bavaria, on the river Altmühl, 56 m. N. N. W. of Munich; pop. in 1871, 7,011. It is the seat of a bishop and has several schools and hospitals. Its manufactures are chiefly woollen and cotton fabrics, iron and stone ware, and beer. The most remarkable public buildings are the castle, the council house, and the cathedral, a fine Gothic edifice. The castle of Wilibaldsburg, which overlooks the town from a height of 1,200 ft., was formerly the residence of the bishops, and is now used for barracks.—Eichstädt was founded by the Anglo-Saxon St. Wilibald, created bishop about 745, whose statue is in one of the public squares. It increased in size through the pilgrimages made to the shrine of St. Walpurgis, whose remains were deposited there in 871, and whose church is still visited annually by thousands of pilgrims. Upon the death of Count Hirschberg, in 1305, the bishopric was endowed with his estates, and afterward it became one of the richest foundations of Germany. It was secularized in 1802, and erected into a principality, and in 1805 was incorporated into Bavaria. The principality was in 1817 assigned with other territory to Eugene Beauharnais, duke of Leuchtenberg. It ceased to be a principality in 1854. The present bishopric of Eichstädt is under the jurisdiction of the archbishop of Bamberg.

**EICHWALD**, Edward, a Russian naturalist, born at Mitau, July 4, 1795. He studied at Berlin, spent several years in travel, and in 1823 was appointed professor of zoölogy and midwifery at Kazan. In 1827 he became professor of zoölogy and comparative anatomy at Wilna, and in 1838 of mineralogy and zoölogy at St. Petersburg. From 1825 to 1827 he explored the Caspian sea and the Caucasus. In 1846 he made scientific excursions in the Tyrol, Italy, Sicily, and Algeria. He also made geological journeys through France, Switzerland, parts of Russia, and the Scandinavian countries. His numerous works, written in Latin, German, French, and Russian, relate chiefly to the botany, natural history, geology, mineralogy, and palæontology of Russia.

**EIDER**, a river of northern Germany, rising near Kiel, and flowing into the North sea not

far from Tönning. Its general course is W., and for a considerable distance it forms the boundary between Schleswig and Holstein. Its length is about 105 m., of which 70 are navigable. With the aid of a canal from Rendsburg to Kiel fiord, this river forms a communication between the North and Baltic seas.

**EIDER DUCK** (*somateria mollissima*, Leach), one of the *fuliginæ* or sea ducks, well known for the remarkable softness of its down and the beauty of its plumage, and common, like other arctic species, to both hemispheres. The bill is elevated at the base, compressed behind the nostrils, divided in front by an acute angle of feathers, flattened at the tip, which is armed with a strong, broad, and hooked nail; the lamellæ are moderate and far apart; the wings are moderate, pointed, the first and second quills longest; the tail short and wedge-shaped; tarsi more than half as long as the middle toe; the toes long, united by a full web. The head is very large, the neck short,

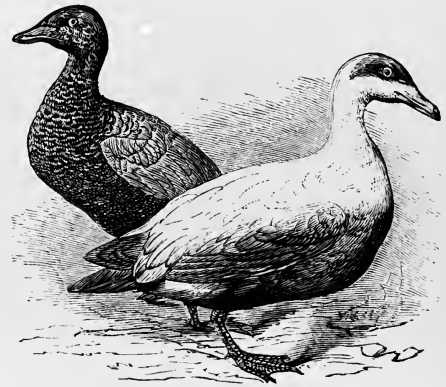

Eider Ducks (*Somateria mollissima*), Male and Female.

the body bulky and much depressed; the feet are short, and placed far behind. The plumage is short, dense, soft, and blended. The bill is short, pale grayish yellow, iris brown, feet dingy light green with dusky webs; upper part of head bluish black, with the central part white; occiput, upper part of hind neck, and sides of neck delicate pale green; sides of head, throat, and neck white; lower neck and upper breast cream-colored or buff; rest of lower surface black, as are the tail coverts and middle of the rump; rest of upper parts white, the scapulars tinged with yellow, except the secondaries, which are brownish black, and the primaries, grayish brown; the length is 25 in., the extent of wings 42, the tail 4½, bill 2¾; the weight is from 4½ to 5½ lbs., greatest in winter. The female differs greatly from the male, being somewhat smaller, and having the general plumage brown barred with black, lighter on the head and neck; secondaries and their coverts with white tips; the young in the first winter resemble the female. The eider is rarely seen south of New York; east of Boston it

is more and more abundant as the latitude increases. Thousands of pairs breed and pass the summer in Labrador, where they are called sea ducks, a name also given to other species; they there begin to make their nests about the last of May, amid the grass and low bushes, and in sheltered places among the rocks; many nests are found near together, made of seaweed, moss, and twigs, each containing from five to seven eggs, about 3 in. long, of a pale olive green; the eggs are considered great delicacies by the fishermen. When the eggs are laid, the female plucks the down from her breast, and places it under and around them, and when incubation commences the male leaves her to take care of her eggs and herself; when she quits the nest in search of food, she pulls the down over the eggs; she leads the young to the water, or carries them thither in her bill, teaches them to dive for food, and protects them from their worst enemies, the black-backed gulls; by the 1st of August old and young are moving southward. In many places the nests are robbed by man of both down and eggs, when the female seeks another male, and lays a second time with the usual quantity of down; if again disturbed, she will try a third time, the down being supplied from the breast of the male. The unnecessary destruction of the birds by the eggers of Labrador has nearly destroyed the trade, and driven them further north. The down of a nest, though bulky enough to fill a hat, when cleared of grass and twigs rarely weighs more than an ounce, though an instance has been related in which the quantity obtained the first time from a single nest is said to have weighed half a pound; when properly cleaned it is worth from 12s. to 14s. per lb. for the English market. So highly is it prized for warmth and lightness, that in Iceland and Norway the districts resorted to by the duck are valuable property, and are strictly preserved. The Icelanders make artificial islands by cutting off projecting points from the mainland, such spots being more attractive to the birds from their seclusion than the mainland itself. Eiders fly rapidly, steadily, and generally near the water, rarely more than a mile from the shore; they are very expert divers, descending several fathoms, and remaining long under water; their food consists of crustacea, mollusks, and the roe of fishes; the gizzard is large and muscular; they are rarely seen inland, unless driven in by storms. They are shy, and difficult to kill; the flesh of the young and females is said to be well flavored, but that of the males is tough and fishy, and rarely eaten. The common eider has been reared in captivity, becoming as gentle and tame as the domestic duck, with which it readily associates; from its eminently social disposition, it would doubtless be a valuable acquisition in a domesticated state, for its feathers and down, for its eggs, and even for its flesh. —The king eider (*S. spectabilis*, Leach) is handsomer than the preceding, and like it is an

inhabitant of the higher latitudes of both continents. The bill of the male is yellowish, the upper mandible having at the base a soft, compressed, orange-colored substance, extending upon the forehead; the front is covered with short black feathers; the general shape is like that of the common eider, and the character of the plumage the same. The iris is bright yellow, feet dull orange with the webs dusky; the head is bluish gray, darkest behind; the sides of the head pale bluish green; a black spot below the eye, and two lines of the same color on the throat; fore neck cream-colored; the sides and posterior part, with a patch on the wings, and one on each side of the rump, white; lower plumage blackish brown; posterior part of back, scapulars, larger wing coverts, and secondaries brownish black, the latter with a greenish gloss; primaries and tail blackish brown; the size is about that of the other species. The female is quite different,

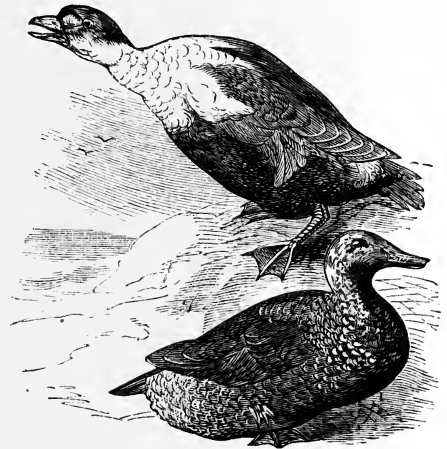

King Eider Ducks (*Somateria spectabilis*).

having the head grayish yellow, with small brownish black lines, the scapulars with brownish red margins, the general color of the lower parts pale yellowish brown, and the quills and tail deep grayish brown; the feathers of the lower neck, breast, sides, and lower tail coverts with a centre and margin of brownish black. The king eider is not often seen in the United States, breeding further north than the common eider; its habits resemble those of the latter species; its home is the sea, the land being visited only in the breeding season; its down is valuable; the eggs are about  $2\frac{1}{2}$  in. long, of a dull greenish color.

**EILDON HILLS**, a group of hills in Roxburghshire, Scotland, consisting of three conical peaks, the highest of which has an elevation of about 1,350 ft. At their foot on the north is the town of Melrose. From their summits a magnificent view of the romantic border scenery of Scotland may be obtained. There is a tradition among the peasants of the neigh-



boring country that these hills were originally one mountain, which was divided into three separate summits by a demon under the wizard Michael Scott.

**EILENBURG**, a town of Prussia, in the province of Saxony, 1½ m. N. E. of Leipsic, on an island formed by the Mulde; pop. in 1871, 10,135. It has many flourishing manufactures, chiefly of cotton and linen goods, chemicals, and tobacco. It received its name from the ancient castle near it, which is mentioned in the 10th century as a seat of the counts of Ilburg, and as an important frontier fortress against the Wends and Sorbs.

**EIMBECK**, or **Einbeck**, a town of Prussia, in the province of Hanover, on the Ilme, 21 m. N. N. W. of Göttingen; pop. in 1871, 6,189. It has manufactories of woollens and linens, several bleacheries and tanneries, and a gymnasium founded by Luther. It was formerly the capital of the county of Mansfeld, and was once prominent among the military towns of the empire, but the French destroyed its walls in 1761.

**EINSIEDELN**, or **Einstedlen**, a village of Switzerland, in the canton of Schwytz, on the Sihl, 20 m. S. E. of Zürich; pop. in 1870, 7,633. It

is about 3,000 ft. above the sea. Adjoining the village is a famous Benedictine abbey whence it derives its name, founded about 900, at the spot where St. Meinrad was murdered, but several times rebuilt. The present edifice, which dates from 1719, is in the modern Italian style, and contains a museum, a library of 30,000 volumes, and a marble chapel wherein is an image of the Virgin that attracts multitudes of Roman Catholics from many parts of Europe. The average number of communicants, chiefly from Switzerland, Germany, and Italy, annually exceeds 150,000. The yearly festival is held on Sept. 14; and in 1861 the thousandth anniversary of the death of St. Meinrad was celebrated with great pomp. Connected with the abbey are an ecclesiastical seminary, a gymnasium, and a lyceum.

**EISENACH**, a town of Germany, in the grand duchy of Saxe-Weimar, formerly capital of the principality of Saxe-Eisenach, 45 m. W. of Weimar; pop. in 1871, 13,967. It is situated on the border of the Thuringian forest, at the confluence of the Hörsel with the Nesse, 712 ft. above the sea, and is the chief station on the Thuringian-Saxon railway. The town is enclosed by a wall, has broad streets generally paved with

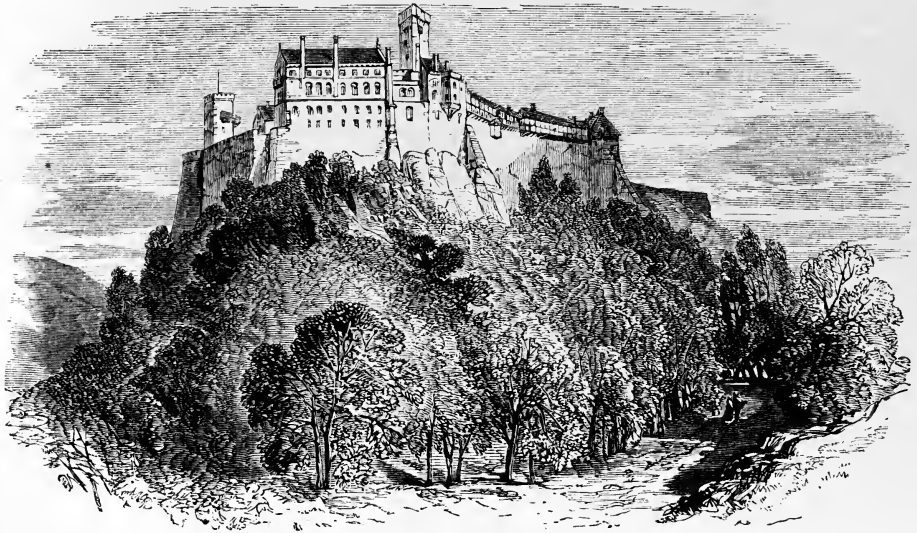

The Wartburg, Eisenach.

basalt, and several remarkable public buildings, among which is the castle, formerly the residence of the princes of Eisenach. Its manufactures are chiefly woollen and cotton fabrics, white lead, and pipe heads of soap stone. In its environs on a lofty height is the ancient castle of Wartburg, once the residence of the landgraves of Thuringia, celebrated as the place where the minnesingers contended for the palm of poetry, and as the asylum where Luther composed his translation of the Bible. The "Evangelical church conferences," consisting of repre-

sentatives of all the governments of Germany and of Austria, for the regulation of the Protestant church affairs of these states, have been held here biennially since 1852.—The ancient principality of Eisenach was in 1440 united with Saxony. Three times, in 1596, 1640, and 1672, a special line of Saxe-Eisenach was founded, but each of them was of short duration; the last became extinct in 1741, when the country was united permanently with Saxe-Weimar.

**EISENBERG**, a town of Germany, in the duchy of Saxe-Altenburg, on an affluent of the

Elster, 40 m. S. W. of Leipsic; pop. in 1871, 5,261. It has a Protestant lyceum, an observatory, and manufactories of china ware and woolen goods. An important trade is carried on in lumber. The ducal castle, Christiansburg, has a beautiful church in Italian style, built from 1676 to 1692. In 1675 Eisenberg became the capital of the new sovereign duchy of Saxe-Eisenberg, which became extinct on the death of its founder, Duke Christian.

**EISENBURG**, a county of Hungary. See VAS.

**EISENLOHR, Wilhelm Friedrich**, a German physicist, born at Pforzheim, Jan. 1, 1799, died in Karlsruhe, July 9, 1872. He studied at Heidelberg, and in 1819 was appointed teacher of mathematical and physical sciences at the lyceum of Mannheim, where he remained till 1840. From that date till 1865 he was professor in the polytechnic institute at Karlsruhe. His principal work is *Lehrbuch der Physik* (1836; 10th edition, 1872).

**EISENSTADT** (Hun. *Kis-Márton*), a town of Hungary, on the slope of the Leitha hills, near the frontier of Lower Austria, 11 m. N. W. of Oedenburg; pop. about 3,000. It consists of the town proper, surrounded by walls, and of the Schlossberg, which formerly belonged to the Esterházy family, and contains a magnificent palace with pleasure grounds, a theatre, and a chapel. The library is rich in church music, masses, and oratorios, and contains some of Haydn's MSS. In a church for pilgrims on a so-called Calvary mountain the remains of Haydn are buried.

**EISELEBEN**, a town of Prussia, in the province of Saxony, 18 m. W. by N. of Halle, on the railway from Halle to Nordhausen and Cassel; pop. in 1871, 13,434. It contains a castle, and has manufactories of linen, tobacco, saltpetre, potash, and copper, the metal being largely mined in the vicinity. The portion called the old town is surrounded with walls. It is noted as the place where Martin Luther was born and died. The house in which he was born was burned in 1689, but that in which he died is still preserved, and has been converted into a school for poor children. In an upper story of the house several relics of Luther are kept, among which is the album of his friend the painter Cranach, who made the designs for his works. In the church of St. Andrew, the pulpit from which Luther preached but a few days before his death is still preserved.

**EISTEDDFODS** (from *eistedd*, to sit), meetings of bards held in Wales down to the time of Queen Elizabeth. Several associations have been formed in modern times in Wales which hold periodical meetings called Eisteddfods, as for example the Gwyneddigion, founded in 1770, the Cambrian, founded in 1818, and the Metropolitan Cambrian institution. They seek to preserve the poems of the ancient bards, and to promote national feelings by awarding prizes for Welsh poems, singing, &c. (See BANDS.)

**EJECTMENT** (Lat. *ejectio firmæ*; Fr. *ejectement de firme*), an action for the recovery of

the possession of lands. It was originally applicable to the case of a lessee for years who had been dispossessed; but by the legal fiction of supposing a lease to the imaginary person John Doe, and that he had been ousted by the other imaginary person Richard Roe, it was gradually made the substitute for the cumbrous real actions of the common law, and has come to be the common action, wherever the common law prevails, for the trial not merely of the right to possession, but to the title. To maintain the action it is sufficient that the plaintiff has a present legal right to possession, whether as tenant to another or as owner of the freehold; and a previous peaceful possession is sufficient evidence of such right as against a mere intruder who shows no right in himself. The legal fictions formerly belonging to this action are now generally dispensed with, and it has become one of the most simple and direct of all legal proceedings.

**EKATERINBURG**. See YEKATERINBURG.

**EKATERINODAR**. See YEKATERINODAR.

**EKATERINOGRAD**. See YEKATERINOGRAD.

**EKATERINOSLAV**. See YEKATERINOSLAV.

**EKHMIN**, or *Akhmin* (anc. Eg. *Khemmin*; Gr. *Chemmis* and *Panopolis*), a town of Upper Egypt, on the right bank of the Nile, 60 m. above Sioot and 75 m. below Kenneh; pop. about 10,000. It stands on the ruins of one of the most ancient cities in Egypt, the capital of the Chemmite nome in the Thebaid, which was dedicated to Khem or Min, whom the Greeks identified as Pan. In the vicinity of the modern town are the remains of several temples and tombs, and large excavations have recently been made which are expected to throw new light on the condition of the ancient empire, and especially on the nature of the worship of Khem, who is believed to have been a phallic deity. The place contains at present the finest Coptic church in Egypt, and a Coptic and a Franciscan convent. The inhabitants carry on a lively trade in cotton goods and agricultural produce. The name of the town is sometimes given as El-Akhmin, and by the Copts as Khmim.

**EKRON**, the most northern of the five Philistine cities, assigned in Joshua's distribution of territory to Judah. The ark was taken to Ekron after its capture by the Philistines. Beelzebub was called the god of Ekron, and was here worshipped, and the prophets made this city the burden of some of their most violent denunciations. Its site is occupied by the town of Akir, 10 m. from the Mediterranean, 15 m. S. E. of Jaffa, and 25 m. N. W. of Jerusalem. The present town is built of unburnt bricks; and as there are no ruins, the ancient city was probably constructed of the same materials.

**ELAGABALUS**, or *Heliogabalus*, *Varius Avitus Bassianus*, a Roman emperor, son of the senator Varius Marcellus and cousin of Caracalla, born in Emesa, Syria, about A. D. 205, killed in Rome in 222. He has been called the Sardanapalus of Rome. While yet a child he

was made priest of Elagabalus, the Syro-Phœnician sun god, in his native city; and the Roman soldiers, beholding the elegant figure of the young pontiff, thought they recognized in him the features of Caracalla. His grandmother, Julia Mæsa, willing to advance his fortune at the expense of her daughter's reputation, spread a report that he was the offspring of an intrigue between her and the murdered emperor. The army, disgusted with the parsimony and rigid discipline of Macrinus, was disposed to admit his pretensions. Elagabalus, as he was called from his sacred profession, took the name of Antoninus, was received with enthusiasm by the troops of Emesa, and declared emperor under the name of Marcus Aurelius Antoninus (218). Macrinus sent detachments of his army from Antioch to crush the rebellion, but the legions murdered their commanders and joined the enemy. At length Macrinus himself marched to meet the pretender, but was signally defeated. He was soon after captured and put to death, and the Roman senate recognized Elagabalus as emperor. His elevation he thought to be due to the power of the sun, which he worshipped in the form of a black conical stone, and Rome saw her hills covered with altars and her streets filled with processions in honor of the god of Emesa. The Palatine hill became the seat of a magnificent temple, where lascivious dances were performed by Syrian damsels. The Quirinal was occupied by a senate of women, who gravely discussed matters of toilet and ceremonial. In a mystical fancy about the sun and moon, he married the Carthaginian priestess of the moon, which was adored in Africa under the name of Astarte. He abandoned himself to the wildest pleasures, but neither a rapid succession of wives, nor a long train of concubines, nor the art of his cooks, could satisfy his passions or save him from satiety. Wearied at length with playing the part of a man, he declared publicly that he was a woman, wished to be dressed like the empress, chose a husband, and worked upon lace. His cruelties were as fantastic as his follies. Having at one time invited the patricians of Rome to a dinner, in the midst of the repast he opened the doors and let in upon them several furious tigers and bears. The patience of the populace and soldiers being exhausted by his vices and tyranny, a sedition was about to break out, when Elagabalus was induced to adopt as his colleague his cousin Alexander Severus. Alexander cherished the rigid manners and primitive usages of Rome, and quickly became the favorite of the army. When Elagabalus sought to withdraw from him the power which he had granted, or to compass his death, the prætorians mutinied, killed the emperor and his mother, and threw their bodies into the Tiber.

**ELAM**, afterward *Susiana* (called by the Greeks *Cissia* and *Susis*), an ancient country of S. W. Asia, bounded N. by the river Diyaleh, E. by the Kebir Kuh range, W. by the Tigris, and S. by

the Persian gulf. It comprised a low and fertile tract, originally peopled by Turanians and descendants of Shem, who were conquered at a very early time by a Hamitic or Cushite race from Babylon. According to the Biblical account, a very important power had been built up in this region by the time of Abraham. The dynasty of the Chaldean empire mentioned by Berosus after the Median or Aryan, occupying the throne from about 2300 to 2100 B. C., was probably of Elamite origin. It is certain that Chedorlaomer, who belongs to this period, was master of the whole Tigro-Euphrates basin, having as vassals Amraphel, king of Shinar, Arioch, king of Ellasar, and Thargal, the Tidal of the Bible, "king of nations," probably nomadic tribes. He made with them an expedition toward the west, temporarily subjugated parts of Syria, plundered the cities of Sodom and Gomorrah, led Lot away captive, and was at last defeated by Abraham. Ashur-bani-pal mentions in two inscriptions that he took Susa 1,635 years after Kedor-nakhunta or Kudur-nanhundi, king of Elam, had conquered Babylonia, which would give the year 2295 B. C. as the date of the establishment of the Elamite dynasty in Chaldea. Other names of Elamite kings of this dynasty, obtained from inscriptions recently discovered, are: Kedor-mabug and his son Zikar-Sin, Burnaburyash I. and his son Kurigalzu I., Ishmi-Dagan and his sons Gungun and Shamshi-Bin. It is certain that Elam was afterward a formidable feudatory of Babylonia and Assyria, and had its own monarchs and an independent government. An inscription of the 9th century includes Elam in the Assyrian empire; and others show that the Assyrian kings were continually engaged in war with Elamites, who in conjunction with Babylon attempted to assert their independence. About 790 the Elamites became again an independent state under Shutruk-Nakhunta. About 60 years after, Sargon or Saryukin defeated, as he relates in his annals, Humbanigash I., king of Elam, in the plains of Kalu. During the time of Sennacherib, 704-680, Elam revolted again under Kedor-nakhunta II. in concert with Babylon. Sennacherib devastated the whole southern part of the country, and captured Suzub, the Babylonian king, who contrived to escape, and "opened the treasure of the pyramid, the gold and silver of the temples of Bel and Zapanit; he plundered them to give to Umman-Minan, king of Elam," brother and successor of Kedor-nakhunta. Umman-Minan accepted the bribe and joined the invasion of Assyria. Sennacherib bribed in turn Humban-undasha, the Elamite general-in-chief, and gained an easy victory over the combined army of 150,000 men. Babylon and Elam made renewed efforts, and Sennacherib, exasperated by these continued revolts, chastised them with the utmost severity, and the sacred city of Babylon, revered by the Assyrians as much as by the Chaldeans, was given

up to be plundered. Esarhaddon or Asshurakhiddin (680-667) established in the Israelitish territory large numbers of captives from the land of Elam. Esarhaddon and his son Asshur-bani-pal were constantly kept busy by the troublesome and rebellious inhabitants of Elam. Nine kings of Elam are mentioned in the inscriptions of these two monarchs. They maintained the struggle against Assyria without abatement, and often came near overwhelming it, but Asshur-bani-pal put an end to it by devastating the whole country, and reducing the populace to slavery. At the subsequent conquest of the Assyrian empire and its division between Cyaxares and Nabopolassar, the Elamite country was assigned to the Medes. It became afterward part of the Persian empire, forming a distinct satrapy and paying an annual tribute of 300 talents. At the time of Darius the Elamites had regained sufficient strength to venture on an insurrection under Martius, the son of Sisiscres, who made himself king, representing himself as Omanes, a descendant of the old native dynasty. Darius relates in the Behistun inscription: "Upon this I was moving a little way in the direction of Elam; then the Elamites, fearing me, seized that Martius who was their chief, and slew him." Shortly after the Elamites joined their old friends the Babylonians in another revolt, which was suppressed in the following year by Gobryas, Darius's general. This was the last effort of the Elamites to regain their independence; their country remained a Persian province, sharing the fortunes of the empire.—In regard to the various names assigned by Greek and Roman writers to the country, Elymais seems to be less comprehensive than Elam, and Susiana and Susis are terms formed artificially from the capital city Susa; Cissia is used by Herodotus as the name of the territory of the Cushites. The modern Khuzistan nearly corresponds to it.

**ELAND**, a name applied by the colonists of the Cape of Good Hope to the impoofoo (*boselaphus oreas*, H. Smith; *oreas canna* of some authors), an antelopean ruminant, resembling the bovine group in stature, shape, dewlap, and high shoulders. The general color above is a grayish yellow, with rusty and purplish shades shining through it; the lower parts cream yellow; the forehead with long, stiff, yellowish brown hairs; face brownish red, chin white, eyes chestnut; a slight brownish yellow mane, along the back becoming reddish brown; muzzle black; hoofs brownish black, edged above with brownish red hair; the tail is brownish red, with a tuft of yellowish brown; the mane of the dewlap is yellowish brown, pencilled with brownish red. This is the color of the male, which has a small head, a neck tapering above, but bulky toward the chest; the body is thick and heavy; the limbs are elegant and slender; the eyes full and soft, and the expression of the face is gentle and ovine; the horns slope slightly back from the crown, being

very thick at the base, with two spiral turns having an obtuse ridge, and the upper two thirds straight, tapering to a point; the ears are long, narrow, and pointed, hairy on both sides; the hair is rather thin, except on the neck, mane, dewlap, and tuft of tail. The length from nose to base of tail is about 10½ ft., the head being 17 in.; the horns are nearly 3 ft. long; the height at the shoulder is 5¾ ft., and at the crupper 2 in. less; the length of the tail 2½ ft., and of the dewlap at its base 20 in. The female is of a pale sienna yellow, deadened with pale brown above; below dirty white, with a cream-yellow tinge; the figure is more delicate and elegant than that of the male, the limbs are more slender, the mane is shorter, the dewlap narrower, the tail less tufted; and the horns are straight, slender, somewhat spiral at the base, with a rudimentary ridge on the spire. The young are of a tint between reddish orange and yellowish brown. This is probably the largest of the antelopes, equalling the horse in

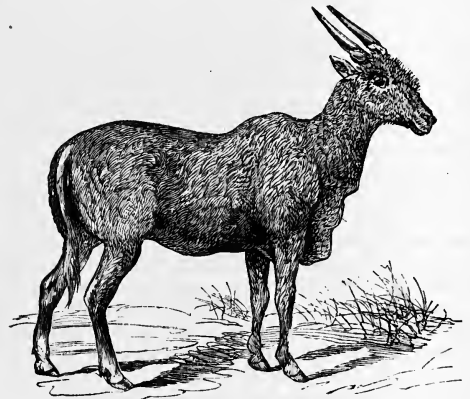

Eland (*Oreas canna*).

height, and weighing from 7 to 10 cwt. It ranges the borders of the great Kalahari desert in herds varying from 10 to 100; rare at present within the limits of Cape Colony, it was found in abundance in the wooded districts of the interior by R. Gordon Cumming. The flesh is most excellent, and is greatly esteemed. When young and not over-fed the eland is not easily overtaken by the Cape horses; but in good pastures it grows so fat that it is easily run down; it is said that when pursued it invariably, if it can do so, runs against the wind, which gives it an advantage in outrunning a horse. The hide is very tough, and much prized for shoes and traces. Like other antelopes, it seems to be independent of water, frequenting the most desert localities far from streams and rivers; except in the breeding season and when pursued, the males generally keep in groups apart from the females. A variety of this species is called bastard eland by the colonists; it is smaller than the other, dark

brownish gray, with a white space between the fore legs. The name of eland, or elk, is applied to this as well as to several other species of deer and antelope by the Dutch colonists of Africa and the Indian archipelago, and is apparently indiscriminately given to any large hollow-horned ruminant; the animal called eland by recent travellers and hunters in south Africa is in most cases the first described species, and probably sometimes the second, as both are found in the same districts, though the herds do not intermingle; they may be the same animal at different ages. These animals are gentle and readily domesticated; but though strong, the shoulders do not possess that solidity which renders common domesticated cattle so valuable. The first specimens brought alive to Europe were received in England in 1842; they all died except one, but others have been imported and the herd has increased rapidly. The first one was killed for the table in 1859; it was five years old, and weighed 1,176 lbs., "huge as a short-horn, but with bone not half the size." The meat resembles beef, with a venison flavor, and has a fineness of fibre and a delicacy of fat which place it high on the list of choice and nutritious articles of food. They are to be seen now in many of the zoölogical gardens of Europe.

**EL-ARAISH**, or **Al-Arish**, also called **LARACHE**, a fortified town of Morocco, capital of the province of Azgar, on the Atlantic coast, 45 m. S. S. W. of Tangier; pop. about 5,000. It is built on two hills on the southern bank of the wady El-Khos or Luccos, is surrounded by walls, and contains an exchange, a bazaar, a fine mosque, and a dilapidated castle occupied by the governor of the province. The fortified harbor is about  $\frac{1}{4}$  m. wide and 1 m. long, with an average depth of 24 ft. The exports consist mainly of grain, wool, hides, beans, and cork. The beautiful orchards and pleasure gardens from which it derives its name are suffering from neglect, though some olives and oranges are cultivated. —The town stands probably on the site of the ancient Lixus, on the river of the same name, but only a few Roman ruins have been discovered here. Opposite, on the right bank of the wady El-Khos, are the ruins of the Phœnician colony Lex or Lix (Arabic, *Teshemis*), and several tombstones with Phœnician inscriptions have recently been found. The wonderful island and gardens of the Hesperides were located by the ancients at the mouth of this river, which accordingly sometimes received the name of Hesperides. The island now found here is about 600 ft. long and 120 ft. wide. The town was occupied by the Portuguese during the 17th century, and became the centre of a large export trade in African produce. In 1829 the Austrian fleet destroyed here the pirate fleet of Morocco.

**EL-ARISH**, or **Kalat el-Arish**, a fortified town in Lower Egypt, on the Mediterranean near the mouth of the wady El-Arish; pop. about 2,000. It is the frontier town between Egypt and

Syria, and as such a great centre of inland traffic between the two countries. Since the construction of railways through the Delta it has lost much of its maritime importance. The fortifications are insignificant.—At this place stood the ancient Rhinocorura or Rhinocolura, an Egyptian penal colony, which is said to have derived its name from the convicts having their noses cut off. Baldwin I., king of Jerusalem, returning from his Egyptian expedition, fell sick and died here in 1118. The French defeated here the Turks, captured the town, and reduced the fort in February, 1799. The place was retaken by the grand vizier in December. The convention for the evacuation of Egypt by the French was concluded here, Jan. 24, 1800, between Gen. Kléber, Sir Sidney Smith, and the grand vizier.

**ELASMOSAURIANS**, a genus of gigantic marine saurians, of the cretaceous epoch, whose remains have been found especially in New Jersey. These, with the huge mosasaurus, the

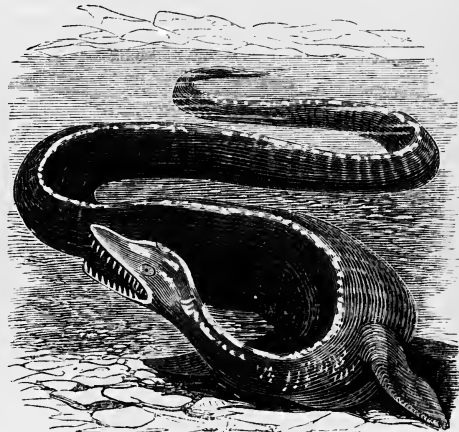

Restoration of an Elasmosaurian.

pythonomorphs of Prof. Cope, were the sea-serpents of the close of the mesozoic age. They seem to have combined the features of serpents, lizards, and plesiosaurs, and to have resembled the *varanidæ* of the tropics of the old world more than any other living type. The *elamosaurus*, with the allied *cimoliasaurus*, both found in New Jersey but not elsewhere in America, and in England, were reptilian whales; the latter genus resembled the plesiosaurus, while the former had an enormously long and flattened tail; in both, the zygapophyses or processes connecting the vertebral arches, are very oblique, with their articular faces turned opposite to that which prevails among vertebrates generally. The *E. platyrus* had vertebræ nearly as large as those of an elephant; the bulk was whale-like, the neck long and flexible, the paddles short, and the tail serpent-like; skull light, with long, narrow, and flat muzzle; nostrils or spout holes near

the orbits; teeth long, cylindrical, very sharp, and fitted for seizing the fish upon which it fed. It attained a length of 45 feet, and might well furnish a model for the modern sea serpent, which in the light of geology is not a zoological impossibility.

**ELASTIC CURVE**, the curve assumed by a straight spring of uniform thickness when the ends are brought forcibly together. It embraces a variety of appearances, simple waves, overlapping waves, a figure of eight, retrograde loops or kinks, ordinary loops, and the circle. The fundamental law or equation of the curve is that the curvature of each point is directly proportional to its distance from a certain straight line on which the curvature is zero; so that when the curve crosses this line it reverses the direction of its curvature.

**ELASTICITY**, the property in virtue of which a body tends to recover its form and dimensions on the removal of the forces by which these have been changed. A perfectly elastic body is defined by Thomson and Tait (1872) as one which "when brought to any one state of strain requires at all times the same stress to hold it in this state, however long it may be kept strained, or however rapidly its state may be altered from any other strain or from no strain to the strain in question." According to Maxwell (1872), a perfectly elastic body is one "which, subjected to a given stress at a given temperature, experiences a strain of definite amount, which does not increase when the stress is prolonged, and which disappears completely when the stress is removed." If the form of the body is found to be permanently altered, its state of stress just previous to the change is called the limit of perfect elasticity. If the stress increases until the body breaks, the value of the stress is called the strength of the material. If breaking takes place before there is any permanent alteration of form, the body is said to be brittle. If the stress, when it is maintained constant, causes a displacement within the body which increases continually with the time, the substance is said to be viscous. Viscosity, whether in solids or fluids, is then intimately connected with their elasticity, and the preceding definitions of elasticity, although popularly associated with the behavior of solid bodies, are equally applicable to liquids and gases; indeed, strictly interpreted, they have reference to the behavior of the molecules and ultimate atoms of which bodies are supposed to be composed. A perfect knowledge of the laws of elasticity is nothing less than a knowledge of the exact laws according to which atoms attract and repel each other, or, more generally, of the ultimate constitution of matter. In this broad sense this subject offers the most important and at the same time the most difficult field of study that can be cultivated by the physicist. The ultimate constitution of matter is in fact as truly the goal of the modern physical and chemical sciences, as the constitution of the universe is the final problem of astron-

omy. The tendency of modern physics is to look with distrust upon all theories of molecular action that assume the principle of action at a distance. When, however, we have attained to a correct knowledge of the internal constitution of bodies, it may be expected that the laws of elasticity will be deduced therefrom by mathematical processes. Until then the subject of our article must be treated inductively, except in so far as we assume the relative position of the particles of bodies to be disturbed only to an indefinitely small degree by the exterior forces; in these cases the molecular motions may be deduced from the established general laws of mechanics, and have indeed been so investigated with great success by a host of scientists, beginning with Bernoulli, Young, Fresnel, and Green. The general investigation of the relation between the strains and deformations of a solid has been shown by Green (1830) to depend upon the solution of a quadratic equation having 6 unknown quantities and 21 terms whose coefficients are essential for a complete theory of the dynamics of an elastic solid subjected to infinitely small strains. **I. ELASTICITY OF MASSES.** The elastic properties of homogeneous bodies relate to the behavior either of the constituent molecules and sensible masses of the bodies or of their ultimate atoms to each other. In considering the latter class of relations we have to do with chemical changes and the properties of heat, light, electricity, and magnetism. Considering the behavior of molecules, we have to do with the laws of strength of materials, elasticity of springs, propagation of sound, &c. The latter class of phenomena will here first attract our attention, and we shall treat in succession of solids, jellies, fluids, vapors, and gases, concluding with some of the relations between the molecular elasticities of these bodies and the agencies of heat, light, and electricity.—Our first ideas as to the elasticity of solids are derived from the properties of extension and compression under forces respectively of tension and pressure. In the second column of the following table is given for each substance the weight necessary to extend by  $\frac{1}{100}$  part of its length (or one centimetre) a bar whose section is one square millimetre, and whose length is one metre :

SUBSTANCE.	Weight in kilogrammes.	Modulus in kilogrammes per sq. mm.	Modulus in pounds per sq. inch.	Specific gravity.	Modulus of length in metres.
Flint glass.....	585.1	5,851	8,800,000	3.3	19,000
Brass.....	1,094.8	10,948	15,500,000	8.3	91,000
Copper.....	1,255.8	12,558	17,800,000	8.9	111,000
Cast iron.....	1,374.1	13,741	19,500,000	7.25	99,000
Wrought iron.....	1,999.4	19,994	28,400,000	7.5	150,000
Steel.....	2,179.3	21,793	30,900,000	7.85	170,000

When the elongations are small they are, according to the law of Hooke, directly proportioned to the tension or the applied weight; therefore in the preceding cases weights ten times as great as those in the second column

will extend the bars to double their original length, if we suppose the material to withstand such a force without breaking; the corresponding numbers are found in the third column of the preceding table, and constitute for each substance the so-called "Young's modulus of elasticity," which may be defined as the weight that will so elongate a bar of unit square section as to double its original length. The moduli given in the third column in kilogrammes per square millimetre may be converted into the British system of pounds per square inch by multiplying by 1,422·3, as given in the fourth column. It is frequently convenient to express the above given weight modulus by an equivalent length of a bar of the same material; this number, which may be called the length modulus, is found by dividing the weight modulus by the weight of the unit of length, or in the French system, by the specific gravity of the substance and multiplying the quotient by 100,000. Thus a bar of glass will be stretched to double its length by the weight of a similar bar of glass whose length is 19,000 metres. In general, for large forces and changes of form that leave a permanent deformation of the solid, the resistance to crushing differs from the resistance to stretching; this is shown by the coefficients of strength for these two kinds of forces; and the difference of bodies in this respect is a highly important element in calculating their fitness for building or mechanical purposes. On the other hand, the effect of an exceedingly small force in producing a slight compression is sensibly equal to the effect of the same force in producing a slight extension; therefore the above given moduli of elasticity hold good for such values of both pressure and tension as do not approach the limit of perfect elasticity. If now a bar of any substance be slightly bent, its convex side is extended, but its concave side compressed; there must therefore be within its substance some neutral line, or axis of no change whatever; this line constitutes the elastic curve of Bernoulli, and has been the subject of many investigations. The exact curvature of this line, or of the bar, is known when the applied forces are given. The formulas relating to the various cases that occur in engineering are given in works on applied mechanics, such as those of Weisbach and Rankine. One of the most interesting and important applications of the elasticity of a plane curved spring is found in the case of the mainspring and especially of the hair spring of a chronometer; the theory of their action has been studied, among others, by Yvon Villarceau (1863). Other applications are found in the dynamometer for measuring great tensions, the horizontal fixed glass thread for weighing minute quantities, the tuning fork and the stretched strings of musical instruments, &c. —The near approach to perfect elasticity that is the property of some bodies, as steel and glass, is evinced by the perfect uniformity of

the times of vibration of the strings, bells, bars, &c., that give out pure musical notes on being struck, and that no matter how extensive their arcs of vibration or how loud their corresponding notes; if the elastic force did not increase precisely in proportion to the amount of the molecular displacement, we should notice discords instead of the single pitch that emanates from the sounding body. The perfect uniformity of these minute vibrations has suggested their application in the sphygmograph and other chronographs, where they replace the pendulum for the measurement of minute intervals of time; indeed, in the chronograph of M. Hipp, a vibrating spring serves also as the regulator of the revolving cylinder. The vibrations of a carefully arranged metallic spring, hermetically sealed in an exhausted glass vessel, and at a standard temperature, depending as they do solely on the elasticity of the body, offer a means of measuring small intervals of time with almost absolute perfection; and Sir William Thomson has suggested that for scientific purposes such an arrangement must be adopted as a standard far more constant than the rotation of the earth or the vibration of a pendulum.—If a straight bar be twisted about its longitudinal axis, an elastic force is brought into play to resist the mechanical couple by which the twisting is effected. This, the elasticity of torsion, does not depend upon that of compression or extension; its modulus must therefore be determined by direct experiment. The laws of the elasticity of torsion have been studied originally by Coulomb, and subsequently by Binet, J. Thomson, and especially by St. Venant (1855) and Thomson and Tait. The principal applications of torsional elasticity are found in the spring balance in ordinary commercial use, and in the torsion balance used in electrical measurements, in the Cavendish experiment, and other delicate researches. In the latter instrument the amount of torsion is evidently a direct measure of the external force applied and to be measured. In the former instrument (the spring balance) the elastic wire is coiled around a cylinder like the threads of a screw, and an external force is applied parallel to the axis of the cylinder to increase or diminish the distance between the coils. The theory of the action of such spiral or helicoidal springs has been developed by Binet (1814), and by Prof. J. Thomson (1848), by whom it has been shown that the force that opposes the elongation or contraction of a helicoidal spring is the elasticity of torsion. Besides the applications above mentioned of the spring balance to commercial uses, it has been proposed to use a very delicate instrument of this construction as a means of investigating the local and general variations of gravity on the earth's surface, for which purpose it possesses some advantages over the pendulum.—The grandest application of the laws of the elasticity of solids that has yet been made consists in the investigation into

the elasticity of the earth, considered as a whole, which is an important element in the theory of oceanic tides. Sir William Thomson, who has given much attention to this problem, concludes (1871) that the earth has considerably more average rigidity than a globe of glass of the same size; were it not so, the yielding of the solid earth to the tidal influence of the sun and moon would to a great degree annul the observed ocean tides.—The elasticity of a body subjected to a severe strain is in general permanently injured; and Messrs. Hodgkinson and Fairbairn (1837) concluded from their experiments on iron, &c., that the limit of perfect elasticity is much lower than was formerly conceived; that, indeed, a permanent set takes place in ordinary cast iron on the application of even a very slight force; and that there is in general no clearly defined limit of perfect elasticity. This conclusion is probably applicable only to the metals as found in commerce, and not to chemically pure homogeneous or crystalline masses. The ease with which a solid body receives a slight permanent set or deformation is expressed by the words soft and plastic, and the stress on a unit section exerted at the time the body breaks or crushes is the coefficient of rupture; at the limit of perfect elasticity the investigation of elasticity proper ceases, and the phenomena become those of viscosity, as previously defined, until the force applied causes a rupture of the body.—In connection with the elastic properties of solids there remain to be noticed the phenomena of impact. When two bodies strike each other, the portions in contact are forcibly compressed; and as no body is perfectly inelastic, they begin to separate as soon as the compression reaches its maximum value. Newton found that the relative velocity of separation after impact bears a proportion to the previous relative velocity of approach, which is constant for the same two bodies; this proportion is always less than unity, but approaches that limit the harder the bodies are. To this proportion the name coefficient of elasticity is frequently given; this, however, is a misnomer, and Thomson and Tait suggest the more appropriate term coefficient of restitution, while others call it the coefficient of impact. The quantity of force, if any, that is apparently annulled on the collision of two bodies, is not destroyed, but is converted into the other forms of molecular elasticity, *i. e.*, the vibrations of sound, heat, light, and actinism, which spread in all directions to indefinite distances from the place of their origin.—Crystalline bodies differ from homogeneous ones, so far as concerns their elastic properties, only in that the coefficient of elasticity varies with the direction of the external forces that produce the strain.—Jellies form a class of solids distinguished by a wide range of distortion possible within the limits of perfect elasticity, or without producing permanent deformation. In solid bodies the limit of perfect elasticity varies

from something indefinitely small, as in most hard bodies, to a number as large as 1.1 or 1.2, as in the case of cork, and to 2 or 3 in the case of India rubber; the latter is, in its purest state, more properly allied to the class of jellies. In the vibration of solids it has been observed that a force generally called internal or molecular friction resists the vibrations and diminishes their amplitude; this resisting force is probably nothing but the transformation of a portion of the vibratory movement of the mass into heat vibrations. The development of internal friction is specially notable in the vibrations of jellies; it is allied to, if not the same as, the property of viscosity in fluids.—The distinctive property of a fluid is that its molecules can quickly, easily, and permanently change their relative positions; a perfect fluid is a body incapable of resisting a change of shape, provided only that its volume be not altered. Fluids are divided into the two classes of liquids and gases, according to the relative values of their coefficients of elasticity and viscosity.—The elasticity of liquids is generally known as their compressibility, which property has reference to the behavior of the interior of a mass of liquid; the phenomena of capillarity, on the other hand, depend on the peculiar elastic condition of the superficial film of a mass of liquid. “The coefficient of elasticity of a fluid is the ratio of any small increase of pressure to the cubical compression thereby produced. The elasticity however varies with certain conditions that may be imposed, such as that the fluid be under a given pressure or exposed to a given temperature. Every substance has two elasticities, one corresponding to a constant temperature, the other corresponding to the case where no heat is allowed to escape from the body during the process of compression. In the latter case the elasticity is always greater than in the case of uniform temperature.” The following are the coefficients of compressibility of several liquids, or the fractions by which the original volume is diminished for an increase of pressure of one atmosphere or about 15 lbs. to the square inch:

Substance.	Coefficient of elasticity.
Mercury at a temperature of 82° Fahr. ....	0.00003
Water “ “ “ 32 “ .....	0.00050
“ “ “ 107 “ .....	0.00044
Alcohol “ “ “ 45 “ .....	0.00084
Ether “ “ “ 32 “ .....	0.00111
“ “ “ 57 “ .....	0.00140

The other and highly important property, the superficial elasticity of liquids, is commonly known as the phenomena of thin films, of capillarity, &c, and is well illustrated by the blowing of a soap bubble, which operation is but the forcible stretching of a superficial sheet of a highly elastic liquid membrane. The superficial tension of the latter may be measured in grammes weight per linear metre or other unit; it is the same whether the globe be hollow or full; it varies with different liquids and with the nature of the gas or other fluid



contiguous to the thin film. The following table contains some results obtained by Quincke; the figures hold good for the temperature of 20° centigrade and the above units of weight and length :

LIQUID.	Tension of surface separating the liquid from	
	Alr.	Water.
	Grammes.	Grammes.
Water.....	8·253	0·000
Mercury.....	55·03	42·53
Olive oil.....	3·760	2·10
Turpentine.....	3·030	1·18

The investigation of the superficial tension of liquids leads to the explanation of the phenomena of capillarity, evaporation, the wetting of surfaces, the condition of vapor in clouds, or of vapor vesicles if such there be, &c.; and thus brings these diverse subjects within the range of the laws of elasticity.—The elasticity of vapors, or more strictly their expansibility, is a matter of such importance in connection with the steam engine, &c., and in meteorology, that it will be specially treated of under those heads. By the removal of pressure or the communication of heat, or both, a solid or liquid may be converted into a more or less perfect gas, usually called a vapor. The vapors generally have coefficients of elasticity that depend almost wholly upon the temperature; a few such are given in the following table, from Regnault :

Temperature, centigrade.	Alcohol, millimetres.	Ether, millimetres.	Water, millimetres.
-20°	3·8	68·9	0·9
0	12·7	184·4	4·6
+20	44·5	432·8	17·4
40	133·7	907·0	54·9
60	350·2	1725·0	145·8
80	812·9	3022·8	354·6
100	1697·6	4958·3	760·0
120	3231·7	7719·2	1491·3
140	.....	.....	2717·6

—The elasticity of a gas is its power to resist compression, and to restore either its original volume or its original tension. At ordinary temperatures all gases are perfectly elastic, so far as the most delicate measures have as yet been able to determine, for the most extreme changes of pressure. The limits of perfect elasticity are therefore practically infinite; thus justifying the law first announced by Boyle, though frequently spoken of as the law of Mariotte, because firmly established by him, that the density of a gas is directly, or its volume inversely, proportional to the pressure. The elasticity of gases, being to a high degree independent of temperature, finds an important application in mechanical engineering, in the transmission of power to great distances by means of compressed air. It is through this elastic property of the air that sounds are conveyed by it at the rate of about 1,100 feet

per second in all directions. II. ELASTICITY OF MOLECULES AND ATOMS. The explanation of the phenomena of heat and light has led to the assumption of the existence throughout all space of a highly elastic gas, the ether of physical science; the vibrations of the molecules of this ether, being communicated to the nerves of the body, produce the sensations of heat and light. This gas is supposed to exist, though in a state of constraint, among the atoms of transparent bodies, and the mathematical development of the nature of its molecular vibrations offers a complete explanation of all the phenomena of optic and thermic science; and indeed, according to Maxwell and Edlund, we can use this same ether for the explanation of the phenomena of electricity and magnetism. Its elasticity is such that heat, light, and electricity are transmitted by it at the rate of about 200,000 miles per second through the interplanetary spaces. It is in general homogeneous, but in the interior of many crystalline bodies its elasticity varies as does that of the material of the crystal, thus producing the phenomena of polarization, double refraction, &c. While heat itself apparently consists of molecular vibrations depending on the elasticity of the ether, it on the other hand exerts a marked and highly important influence over the elasticity of bodies. So intimate is this connection that it may indeed be doubted whether the elasticity of the ether can be properly spoken of as distinct from the elasticity of the more material bodies that are recognized by the methods of chemical science. In general an excess of heat induces such molecular vibrations that the constituent atoms become separated from each other, producing in the chemical nature of the body the changes known as dissociation, changes that may be compared with the rupture or crushing of a solid mass when subjected to too great a stress. When, on the other hand, a more moderate degree of heat is applied, most interesting changes occur, which will be briefly indicated in so far as they affect the elasticity of the substances. The elasticity of solid bodies is in general diminished by heat, thus tending to lengthen the time of vibration of chronometer springs, tuning forks, &c., retarding the velocity of sound waves, contracting the limits of perfect elasticity, diminishing the force of cohesion or the strength of the material, increasing its plasticity, diminishing its viscosity, &c. Iron and steel are among the few known instances of departure from this general rule. The elasticity of liquids is so affected by heat that, according to Gladstone and Dale, the index of refraction and the coefficient of dispersion diminish as the temperature increases. An increase of temperature diminishes the compressibility of water, but increases that of ether, alcohol, and chloroform. With regard to vapors and gases there seems to be one uniform rule, *i. e.*, that an increase of heat increases the elasticity of these forms of matter. The pre-

ceding table from Regnault has shown the connection between temperature and elastic pressure for some of the more interesting vapors. For short distances on either side of the boiling point of a liquid the elasticity of its vapor approximately varies directly as the temperature, as was first propounded by Dalton. In considering the effects of heat on the elasticity of a vapor or a gas, it is necessary to distinguish between (1) the elastic pressure exerted by a gas that is confined within a constant volume and has its temperature altered by external heat, and (2) the pressure exerted by a gas that is compressed by external force to a smaller volume, but whose temperature is not altered. The former is the elasticity under constant volume or the expansion under constant pressure; the latter is the elasticity under constant temperature, and is for perfect gases expressed by Boyle's law, which however holds good only approximately for vapors. Gay-Lussac has shown that the expansion under constant pressure is sensibly the same for all perfect gases, and is such that the volume increases by 0.002036 of its original value for an increase of 1° F., or by 0.00367 for an increase of 1° C. This law was fully confirmed by Regnault, who showed that it is only approximately true when gases or vapors approach the point of liquefaction. The effect of heat on the elasticity of a gas is so combined with its effect on the density as in general to increase the velocity of the transmission of sound. Thus in air at a pressure of 30 inches the velocity in feet per second is 1,089 at a temperature of 32° F., but is 1,131 at a temperature of 70° F.

**ELATERIUM** (Gr. *ἐλαττειν*, to drive out), a substance deposited by the juice of the fruit of *momordica elaterium*, or squirting cucumber, a plant of the order *cucurbitacea*, growing in the south of Europe. (See CUCUMBER.) It is found in thin flat cakes of a gray or greenish color, which have a feeble odor and a slightly bitter taste. Its medicinal activity depends upon a crystalline, neutral, active principle, called elaterine. This is insoluble in water and alkaline solutions, sparingly soluble in dilute acids, and freely soluble in alcohol. The proportion of elaterine in different specimens of elaterium varies exceedingly, and the medicinal activity of the latter article varies proportionally. Elaterium and its active principle elaterine are violent cathartics, and also increase somewhat the secretion of urine. In small doses, that is, from  $\frac{1}{15}$  to  $\frac{1}{12}$  of a grain of elaterine and from  $\frac{1}{8}$  of a grain to 2 grains of elaterium, these articles produce copious watery discharges, which are frequently attended with nausea, vomiting, and depression. In larger doses they act with great violence upon the stomach and bowels, and in still larger doses excite an inflammation of these organs which has sometimes proved fatal. Their action is rapid. They generally purge in an hour or less, and a legitimate dose may be repeated in an hour if it has not acted by

that time. On account of the energy of their operation, they are not much used medicinally except when, in the treatment of dropsy and disease of the kidneys, it is desirable to obtain copious, frequent, and watery evacuation. They should always be administered cautiously, and never given when great constitutional weakness exists.

**ELATH** (in Josephus *Ælane*, in Roman geography *Elane*, now *Ailah*), a seaport of ancient Idumæa, on the shore of the eastern or Elanitic gulf of the Red sea, now the gulf of Akabah. It was a part of David's conquest from the Edomites; was a place of great importance in Solomon's time, as the port in which he built and fitted out his ships for bringing gold from Ophir; was captured by the revolted Edomites in the reign of Joram, after having been in the possession of the Israelites 150 years; was retaken by Uzziah, who fortified it anew, peopled it with his own subjects, and restored the trade to Ophir; was afterward taken by Resin, king of Damascus, who in turn was deprived of it by Tiglath-pileser, king of Assyria, from whose time it was never recovered by the Jews. Later it fell under the power of the Romans, became the residence of a Christian bishop, and submitted to the Moslems, its governor paying them an annual tribute. In 1116 it was taken by King Baldwin of Jerusalem, and in 1067 was again wrested from the Christians by Saladin. Edrisi describes it as a small town frequented by Arabs, and forming an important point on the route between Cairo and Medina. Elath adjoined Eziongeber; and Akabah now occupies the site of one or both of these ancient towns.

**ELBA**, an island in the Mediterranean, belonging to the Italian province of Livorno, separated from the mainland by the strait of Piombino; length about 18 m., greatest breadth 12 m.; area, about 90 sq. m.; pop. about 20,000. Its outline is irregular, the mountains which traverse the island rising in some parts more than 3,000 ft., and being indented by deep gulfs and inlets, so that its breadth in some places does not exceed 3 m. The soil is fertile, but only a small portion is under tillage. The valleys abound with fruit trees, but are not well cultivated, and the fruits are of inferior quality, excepting oranges. Among the annual products of the island and its waters are red and white wine, marine salt, tunnies, sardines, anchovies, and other fish, and iron, for which the island has always been celebrated. The iron is found in a mountain near Rio, on the E. coast, about 2 m. in circumference, 500 ft. high, and yielding from 50 to 75 per cent. pure metal. There are quarries of granite in the S. W. part of the island, in which crystals of red and green tourmaline and emeralds are found. The principal towns are Porto Ferrajo, Porto Longone, Rio, and Marciana. The island was called *Æthalia* by the Greeks and *Ilva* by the Romans, and was noted for its minerals. Ancient ruins

are still visible in several places. During the middle ages it was ruled by various Italian princes and chiefs. In 1548 Charles V. ceded the territory of Porto Ferrajo to Tuscany. Afterward the island was successively governed by Spain, Naples, and the lords of Piombino.

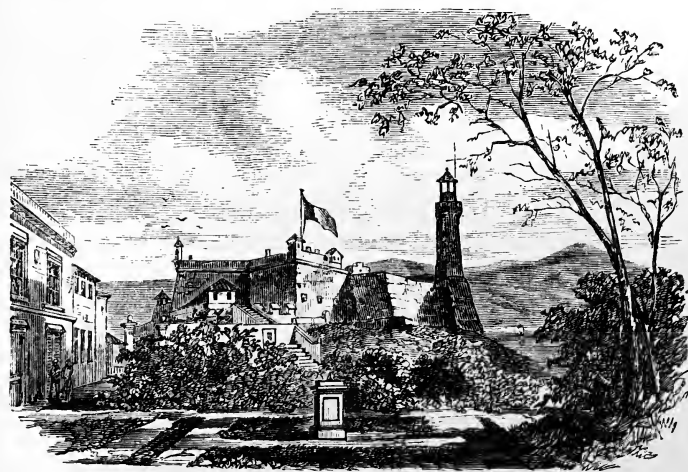

Porto Ferrajo, Elba.

From July, 1796, to April, 1797, it was occupied by the British. It was then ceded to France, and in 1801 united with the new kingdom of Etruria. The treaty of Paris in 1814 erected Elba into a sovereignty for Napoleon I., who resided there from May 4, 1814, to Feb. 26, 1815. During his brief sovereignty Napoleon caused a road to be built uniting Porto Ferrajo with Porto Longone. The villa of San Martino near Porto Ferrajo, which was occupied by Napoleon, has been converted into a Napoleonic museum, and contains various objects of interest relating to the first empire. (See *Napoléon à l'île d'Elbe*, by Amédée Pichot, Paris, 1873.) In 1815 Elba reverted to the grand duke of Tuscany, and with the rest of his territory was annexed to the kingdom of Italy in 1860.

**ELBE** (Bohem. *Labe*; anc. *Albis*), a river of Germany, rising in Bohemia, near the frontier of Prussian Silesia, and flowing into the North sea below Glückstadt in Holstein. It is about 700 m. long. It originates in a number of springs on the western slope of the Schnee-Koppe (snow summit), one of the peaks of the Riesengebirge, at an elevation of about 4,500 ft.; runs mainly in a N. W. course; is navigable from its confluence with the Moldau, and has but a very slight inclination, its bed 40 m. from its sources being but 658 ft. above the sea. Its chief affluents are: on the right, the Iser, Black Elster, and Havel; on the left, the Moldau, Eger, Mulde, Saale, Jetze, Ilmenau, and Oste. The chief places on its banks are Josephstadt, Königgrätz, Theresienstadt, and Leitmeritz, in Bohemia;

Pirna, Dresden, and Meissen, in Saxony; Tor-gau, Wittenberg, Magdeburg, Lauenburg, Altona, and Glückstadt, in Prussia; and Hamburg. Its channel between Hamburg and the sea admits of the passage of vessels drawing 14 ft. of water at all times, but is much encum-

bered with sand bars and shoals. By means of its own waters and those of the numerous canals branching from it, the Elbe places all N. W. and central Germany in connection with the seaboard. Wood, stones, fruits, and earthenware are exchanged through it for corn, salt, and colonial produce. But until recently its navigation has been much complicated by the regulations of the states through which it runs. These regulations were the subject of much controversy and negotiation. By the *Elbschiffahrtsacte* of June 23, 1821, the entire

navigation of the Elbe was thrown open to the commerce of the world, and the charges to which it was subject were fixed and rendered uniform. The regulations were still further modified by conferences which were held from time to time for their revision, and particularly by the additional act of April 13, 1844. The toll collected at Stade was abolished July 22, 1861, and finally all the remaining tolls were removed by act of the North German confederation, which went into operation July 1, 1870. The numerous river transportation companies are thus enabled to compete at better advantage with the railways, and the amount of business has been much increased.

**ELBERFELD**, a city of Rhenish Prussia, on the Wupper, a branch of the Rhine, in the district and 16 m. E. N. E. of the city of Düsseldorf, with which it is connected by the Bergisch-Märkische railway; pop. in 1871, 73,394. The town of Barmen adjoins it on the east, and the two towns taken together form one of the most important manufacturing centres of Germany. The number of looms in Elberfeld employed in the cotton manufacture in 1871 was estimated at 6,000, and the value of the products at \$13,000,000. There are besides large manufactories of silks, ribbons, carpets, carriage and furniture stuffs, buttons, machinery, &c. The establishments for dyeing are particularly celebrated. The railway has its principal office here, and every year extends its connections. A large amount of business is transacted at the two fairs which are held here annually. The finest public buildings are the council house, the court house, the new post

office, the railway station, the casino, the hospital, and the orphan asylum. It is the seat of a mercantile and other courts; has a gymnasium, and numerous schools, including one for teaching the management of the Jacquard loom and pattern drawing. Elberfeld is the centre of the Protestant Bible and missionary societies. It was originally settled in 1527 by refugees from the Netherlands, and of late years has increased in importance from the adoption of improvements in spinning. Though the town is mainly of recent origin, it is irregularly built, but the number of handsome private residences is increasing. West of the town is a hill called the Haardt, on which stands a round tower commanding a fine view of the valley of the Wupper; it is surrounded by a handsome park.

**ELBERT**, a N. E. county of Georgia, separated from South Carolina by the Savannah river, bounded S. and W. by Broad river; area, 514 sq. m.; pop. in 1870, 9,249, of whom 4,863 were colored. The surface is hilly, and the soil, particularly near the rivers, is fertile. Near the Savannah river are several remarkable artificial mounds, one of which is 40 or 50 ft. high and has a large cedar growing on its summit. The chief productions in 1870 were 22,736 bushels of wheat, 140,435 of Indian corn, 13,263 of oats, and 3,035 bales of cotton. There were 1,051 horses, 1,848 milch cows, 2,957 other cattle, and 7,097 swine. Capital, Elberton.

**ELBEUF**, a town of Normandy, France, in the department of Seine-Inférieure, on the left bank of the Seine, 13 m. S. S. W. of Rouen, and 63 m. N. W. of Paris; pop. in 1866, 21,784, and rapidly increasing. It manufactures double-twilled and water-proof cloth, billiard-table cloth, flannels, zephyrs, and light woollens of high finish. It has also dye houses, founderies, machine shops, and manufactories of soap and chemicals. The total value of goods manufactured annually is estimated at nearly \$18,000,000. Many of the workmen employed reside in neighboring villages; the whole number is estimated at 24,000. The town has eight artesian wells and six public fountains. There is daily communication with Rouen by steamers, and Elbeuf is connected with the village of St. Aubin, on the opposite side of the river, by a suspension bridge. It has a tribunal of commerce, a library, societies for the encouragement of the industrial arts, &c. The finest churches are those of St. Étienne and St. Jean.

**ELBING**, a town of Prussia, in the province of West Prussia, and in the district and 34 m. E. S. E. of the city of Dantzic, situated upon a river of its own name, 5 m. from the Frische Haaff; pop. in 1871, 28,600. The city is composed of the old and new towns, and several suburbs, and is in part enclosed within ancient fortifications. It has one Catholic and nine Protestant churches, a synagogue, a gymnasium in which is the city library of 24,000 volumes, and several hospitals and charitable

institutions, including one founded by an Englishman named Cowle, in which 400 children are educated. The principal manufactures are of sugar, pearlsh, tobacco, soap, chicory, vitriol, sail cloth, and leather and woollen fabrics. Ship building, especially of iron, has of late become of great importance. On account of the shallowness of the Frische Haaff, foreign commerce is carried on by way of the Kraffohl canal (from Elbing to the Nogat, a branch of the Vistula) and Dantzic; but as Elbing communicates with the lakes of E. Prussia through the Oberländische canal, its inland business is large. The chief exports are grain, timber, staves, hemp, flax, feathers, horse hair, wool, fruit, butter, and manufactured goods.

**ELBURZ**, *Elbruz*, or *Alburj*, a lofty range of mountains extending over northern Persia, connected on the west with those of Armenia and with the great Caucasus chain, and eastward with the Paropamisian range. It averages from 6,000 to 8,000 ft. in height, the highest peak, Mt. Demavend, being about 18,000 ft. (See *DEMAVEND*.) It enters N. Persia from the Caucasus, and runs for some distance parallel with the S. shore of the Caspian to Astrabad, whence it branches off in an easterly direction toward Afghanistan and Turkistan. By the Sahund mountains it also connects with the Zagros range on the Turkish border. The valleys of the Elburz, especially toward the S. declivities, are exceedingly fertile. In the slope of the mountains opposite Teheran is the tract of Shama-i-Iran or Shamirun (*i. e.*, the light of Persia), extending over 20 m., and containing nearly 40 villages surrounded by gardens and famous as summer resorts. The most celebrated pass is that of Sardari, known to the ancients as the Caspian gates, situated about 55 m. S. by E. of Mt. Demavend, and extending nearly 30 m. in a narrow road between high rocks, forming a barrier against foreign enemies.—One of the principal summits of the Caucasus range is also known as Mt. Elbruz, or Elburz, 18,514 ft. high. (See *CAUCASUS*.)

**ELCSAITES**, a sect of Asiatic Gnostics, founded in the reign of Trajan, about the beginning of the 2d century, a branch of the Jewish Essenes, kindred to and finally confounded with the Ebionites. A Jew named Elxai or Elkesai is supposed to have been their founder. Their most distinctive tenet was that man is but a mass of matter in which the divine power is concealed. They believed in the repeated and continuous incarnation of Christ, were tenacious of their oaths, practised circumcision, abstained from meat, favored early marriages, and rejected portions of the Old Testament and the epistles of Paul.

**ELCHE** (anc. *Nici*), a town of Spain, in the province and 16 m. S. W. of the city of Alicante, on the river Tarafa, 10 m. from the Mediterranean; pop. (including the surrounding plantations) about 20,000. It is girdled on every side by forests of palm trees, and has

been named the city of palms. The chief industry is the culture of dates, which is conducted with great skill. The leaves of the male and barren female palms are sent to all parts of Spain for use in the processions and decorations of Palm Sunday.

**ELCHINGEN, Ober and Unter**, two villages of Bavaria, situated on the sides of a steep mountain near the Danube, about 3 m. apart and 7 m. N. E. of Ulm. At Ober Elchingen was fought, Oct. 14, 1805, one of the most famous battles of the campaign of Austerlitz. For his conduct in this battle Marshal Ney received the title of duke of Elchingen. In the upper village is a Benedictine abbey founded in 1128, and celebrated in the middle ages.

**ELDER**, an overseer, ruler, or leader. The reverence paid to the aged in early times was doubtless the origin of this title, it being used as a name of office both among Jews and Christians. Macknight thinks it was applied in the apostolic age to all, whether old or young, who exercised any sacred office in the Christian church. Elders or seniors, in the ancient Jewish polity, were persons noted for their age, experience, and wisdom; of this sort were the 70 whom Moses associated with himself in the government of Israel, and such also were those who afterward held the first rank in the synagogue as presidents. In church history, elders were originally those who held the first place in the assemblies of the primitive Christians. The word presbyter is sometimes used in the New Testament in this signification, and as interchangeable with ἐπίσκοπος; and hence the first meetings of Christian ministers were called *presbyteria*, or assemblies of elders. Among the Baptists, ministers of the gospel generally are called elders. In the Presbyterian churches they are the officers who, in conjunction with the ministers and deacons, compose the church session, representing the church itself, conducting its discipline, and aiding in the promotion of the interests of religion. They are chosen from among the people, usually for life; are generally set apart to their office with some public ceremony; and their number is different in different churches.—It has long been a matter of dispute whether there are any such officers as lay elders mentioned in Scripture. On the one side, it is said that these officers are mentioned separately from the brethren, and that their office is described as being distinct from that of preaching, he that ruleth being expressly distinguished from him that exhorteth or teacheth. On the other side, it is contended that the distinction alluded to does not refer to different orders of officers, but only to the degree of diligence with which they discharge their duties.

**ELDER**, the popular name of plants of the genus *sambucus*. The most common American elder, *sambucus Canadensis*, Linn., is a showy shrub, well known from its numerous flat cymes of white flowers appearing in June, to

be succeeded by heavy black-purple, crimson-juiced berries in August, and overtopping the wild reeds and bushes on the borders of fields. On account of its long and spreading roots it is sometimes troublesome to the farmer. A wholesome sudorific decoction is prepared from its flowers, which are carefully gathered and

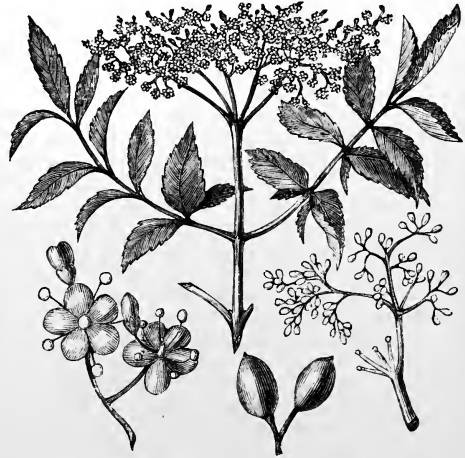

*Sambucus Canadensis*.

dried for the purpose; the fruit is much esteemed by some in the manufacture of a sort of wine, while the pith of the stem furnishes excellent pith balls for electrical experiments. The parsley-leaved elder (*S. laciniata*), an English variety, is one of the more ornamental species, and is often cultivated. It is one of



*Sambucus laciniata*.

the kinds most frequently used for medicinal purposes. The downy elder (*S. pubens*) has handsome flowers, of a greenish or purplish-white, borne in thyrses-like spikes, and a scarlet fruit, fully ripe at the time *S. Canadensis* is in

blossom. There are two very variable species of elder indigenous to Great Britain; the *S. Canadensis* and *S. pubens* are the only species peculiar to North America; southern Europe has three species, and China one.

**ELDON, John Scott**, earl of, lord chancellor of England, born in Newcastle-upon-Tyne, June 4, 1751, died in London, Jan. 13, 1838. He became a fellow of University college, Oxford, in 1767, in 1771 gained a prize for an English prose essay, and in 1772 forfeited his fellowship by a runaway marriage. The forfeiture not taking effect for a year, he resumed his studies at Oxford with the intention of taking orders, if a living fell vacant during that period. This not having been the case, he devoted himself to the study of the law, removed to London in 1775, and entered the office of a conveyancer. He was called to the bar in 1776, and for several years attended the northern circuit without much success. In 1780-'81 he distinguished himself in the case of *Ackroyd v. Smithson* and in the Clitheroe election case, and his professional success was assured. His receipts ranged from £6,054 in 1785 to £10,557 in 1798. He was made king's counsel in 1783, and in the same year became a member of the house of commons, where he kept his seat till he entered the house of lords. He was knighted in 1788, and appointed solicitor general, and in 1793 attorney general, which office he held till 1799, conducting the state trials of 1794 against Horne Tooke, Hardy, and others. In 1799 he was appointed chief justice of the common pleas, created Baron Eldon of Eldon, and entered the house of lords. He proved a consummate common law judge. He became lord chancellor in 1801, and held the office for 26 years, with the exception of the time (1806-'7) during which it was filled by Erskine. As head of the court of chancery, though distinguished for his knowledge of the law and the acuteness and subtlety with which he applied it, he encumbered the court with arrears, and caused great prejudice to the suitors immediately interested by his delay in rendering his judgments. The language in which they were stated was also obscure; but the extreme care with which they were prepared gives them high value as precedents. In the cabinet he had great influence; and under George III. he was said to have sometimes used the great seal in the name of the king even when the king was suffering from mental incapacity. He took part in all important debates in the house of lords, vigorously supported tory principles, and was earnest in his opposition to parliamentary reform and to the Catholic emancipation bill. He was created Viscount Encombe and earl of Eldon in 1821.—See "The Public and Private Life of Lord Chancellor Eldon, with Selections from his Correspondence," by Horace Twiss (3 vols. 8vo, 1844), and "Lives of the Lord Chancellors," by Lord Campbell.

**EL DORADO** (Span., the golden), a country which, during the 16th and 17th centuries, and

to some extent during the 18th century, was supposed to lie somewhere in the new world. Men's imaginations were inflamed by the riches actually discovered in Mexico and Peru, and they conceived a belief that there was an undiscovered country in which gold was even more abundant. Many attempts were made to discover it. Orellana, the lieutenant of Pizarro, reported that he had obtained definite information in regard to it on his voyage down the Amazon in 1540-'41. He pretended to have visited Manoa, its capital, and to have seen there immense treasures of gold and jewels. Martinez, a Spaniard, asserted that he resided seven months in the country, and gave full particulars in regard to its ruler and inhabitants. The two expeditions of Sir Walter Raleigh to Guiana (1595 and 1617) were undertaken in quest of this country. The faith in its existence was so enduring that Spanish expeditions on the same errand took place even in the latter part of the 18th century.

**EL DORADO**, an E. county of California, drained by three forks of the American river and by the Cosumnes; area, 1,872 sq. m.; pop. in 1870, 10,309, of whom 1,582 were Chinese. It is crossed by the Sierra Nevada. It is one of the richest mining counties in the state, and mining is the chief industry. Besides gold, rich copper ore and excellent marble are found. There is also considerable timber and tillable land. The Placerville and Sacramento Valley railroad terminates in the county. The chief productions in 1870 were 3,997 bushels of wheat, 8,642 of barley, 6,235 tons of hay, 215,530 lbs. of butter, 50,096 of wool, and 118,831 gallons of wine. There were 2,098 horses, 3,809 milch cows, 5,402 other cattle, 17,387 sheep, and 4,123 swine; 39 quartz mills for the production of gold, 21 saw mills, and 2 flour mills. Capital, Placerville.

**ELEANOR OF AQUITAINE**, queen of France and afterward of England, born about 1122, died about 1203. She was the eldest daughter and heiress of William IX., duke of Guienne or Aquitaine, and was married in 1137 to Prince Louis, who in the same year succeeded to the throne of France as Louis VII. She was a lover of poetry and art, and could not sympathize with her ascetic husband. She accompanied him on the second crusade to the Holy Land in 1147. At that time he complained of her preference for other men, and on their return from Asia they were divorced, March 18, 1152. A short time afterward she bestowed her hand upon Henry Plantagenet, the future Henry II. of England. This alliance, which made Henry master of Eleanor's possessions in France, produced protracted wars between the two countries. She bore him many children; but his infidelities and neglect having changed her love into hatred, she incited her sons Geoffrey and Richard to rebel against their father, was arrested in 1173, and remained in confinement until after Henry's death in 1189. She was released by his suc-

cessor, Richard I., Cœur de Lion, who placed her at the head of the government on his departure for the Holy Land. She negotiated his marriage with the daughter of the king of Navarre, and went to Germany with his ransom from captivity. She afterward retired to the abbey of Fontevrault, and surviving Richard, lived to see him succeeded by one of her other sons, John, the signer of Magna Charta.

**ELEATIC SCHOOL**, a group of Greek philosophers, beginning with Xenophanes of Colophon, who settled in Elea or Velia, a Greek colony of southern Italy, in the latter part of the 6th century B. C., and whose principal disciples were Parmenides and Zeno, both of Elea, and Melissus of Samos. Some of the ancients also ranked Leucippus and Empedocles among them, but for this there is no evidence. The general spirit of the school may be defined as an attempt, perhaps the first ever made, to refer all science to the absolute and pure ideas of the reason. There are, according to the Eleatics, two kinds of knowledge, that which comes to us through the senses, and that which we owe to the reason alone. The science which is composed of the former is only an illusion, for it contains nothing true, fixed, and durable. The only certain science is that which owes nothing to the senses, and all to the reason. Children and the untaught may believe in the reality of sensible appearances, but the philosopher who seeks the foundation of things should appeal only to the reason. There are two principles in nature, on the one side fire or light, and on the other night, or thick and heavy matter. These principles are distinct but not separate; they act in concert, playing together a perpetual and universal part in the world. The world is bounded by a circle of light as by a girdle, and is divided into three parts, in the central one of which necessity reigns supreme. The stars are but condensed fire, and the earth is the darkest and heaviest of all bodies. It is round, and placed by its own weight in the centre of the world. Men are born of the earth, warmed by the solar rays, and thought is a product of organization. From this commingling of fire and earth have begun all the things which our senses show us, and which will some time perish. But in all these physical phenomena there is no true science. Reason is the exclusive source of certainty, and reason conceives and recognizes as true nothing but absolute being, being in itself considered, that is, as disengaged from every particular, fleeting, and perishable circumstance, modification, or accident. Thus everything which has ever begun to be, everything which is susceptible of change or modification, of birth or destruction, has no veritable existence; it is not being, but only appearance. Besides being, in this sense of the word, there is, according to the Eleatics, only nothingness; and as this is but the negation of all things, one can neither affirm it nor deny it. Being is eter-

nal, unchangeable, self-existent; it has neither past nor future, neither parts nor limits, neither division nor succession; it is then an absolute unity, and everything else is but an illusion. Thus, the Eleatic system denies the data furnished by the senses, denies the generalizations and abstractions which the reason found upon such data, and affirms only those necessary ideas which the reason owes solely to itself, and which it employs in its operations. The result is a pantheism, in Xenophanes resembling the blended material and spiritual pantheism of Spinoza, and in Parmenides approaching the spiritual idealistic pantheism of Fichte.

**ELEAZAR** (Heb., God is help), the name of several ancient Hebrews, of whom the following are the most important. **I.** The third son of Aaron, who held in his father's lifetime the oversight of the Levitical order, and on Aaron's death was raised to the dignity of high priest. His pontificate was contemporary with the military government of Joshua, and the book of Joshua closes with an account of his death and burial. **II.** One of David's three mighty men, who smote the Philistines till his hand was weary, and who with two others broke through the Philistine host to bring to David a draught of water from the well at Bethlehem.

**ELECAMPANE** (Fr. *érule campana*, from Lat. *inula campana*), the common name of the *inula helenium*, a handsome herb of the order *composita*, which, introduced into America from Europe, is now common in our gardens, and grows wild in meadows and by the roadsides in the northern states. The root should be dug in autumn and of the second year's growth. It has an agreeable aromatic odor



Elecampane (*Inula helenium*).

when dried, somewhat like that of camphor, and its taste when chewed is warm and bitter; water and alcohol extract its peculiar properties, the latter most readily. Its extracts afford the vegetable principles alantine or inuline, resembling starch, and helenine, which

forms long white crystals. The powdered root or the decoction in water is used in medicine as a tonic and stimulant. It is prescribed, if at all, in chronic diseases of the lungs. It is known in medicine by the name of inula. The dose of the powder is about a drachm; of the decoction one or two fluid ounces.

**ELECTOR**, or **Prince Elector** (Germ. *Kurfürst*), in the old German empire, the title of the princes who elected the emperor. The electoral privilege had its origin in the right assumed by the powerful nobles, who acquired supremacy in Germany after the extinction of the Carolingian dynasty, of choosing one from their own number to be their head. In the ordinance issued by the emperor Charles IV. in 1356, known as the "golden bull," the archbishops of Mentz, Treves, and Cologne, the count palatine, the duke of Saxony, the margrave of Brandenburg, and the king of Bohemia were recognized as the persons in whom this right was vested. These electors formed an electoral college, had the rank of king though without the title, and were possessed of various important rights and privileges. The electoral rights of the count palatine having been transferred during the thirty years' war (1623) to the duke of Bavaria, an additional or eighth electorate was created for the palatinate in 1648, which ceased to exist in 1777, when the house of Bavaria became extinct. Brunswick-Lüneburg was created an electorate in 1692. (See HANOVER.) When the left bank of the Rhine was ceded to France in 1801 by the treaty of Lunéville, changes in the electoral college became necessary, and were made in 1803. In place of the three ecclesiastics who were previously members of the college, the margrave of Baden, the landgrave of Hesse-Cassel, the duke of Würtemberg, the grand duke of Tuscany, who was also archbishop at first of Salzburg and afterward of Würzburg, and the archbishop of Mentz, with the style of archchancellor of the German empire, were confirmed in the electoral right. The whole electoral system, however, soon afterward (1806) came to an end upon the renunciation by the emperor Francis of the title of emperor of Germany. After that event most of the electors were designated by other titles. Hesse-Cassel ceased to be an electorate during the time it was merged in the new kingdom of Westphalia, but resumed the name upon the dissolution of that kingdom in 1813, and continued to be known by it until annexed to Prussia in 1866.—In the United States electors are chosen by the people of each state to elect the president and vice president. Each state chooses as many electors as it has members in the two houses of congress; and these electors meet at the capitals of their respective states, on the first day of January next after the election, and cast their votes for president and vice president. These votes are then sealed up and carried by special messengers to Washington, where they are opened and counted before

both houses of congress, and the result proclaimed by the president of the senate.

**ELECTRA**, in Greek legend, daughter of Agamemnon and Clytemnestra, and sister of Orestes, Iphigenia, and Chrysothemis. The crimes of her mother and Ægisthus threw her into great distress. Fearing for the life of her younger brother Orestes, she sent him under the protection of a slave to King Strophius of Phocis. When he was grown up to manhood she instigated him to avenge their father's death, and became his accomplice in the murder of their mother. She subsequently married her brother's friend Pylades, and became the mother of Medon and Strophius. Her tomb was shown in later times in Mycenæ. There are different versions of her story, which was used by the Attic dramatists Æschylus, Sophocles, and Euripides, the "Electra" of Sophocles being one of his most famous plays. It has also furnished a subject for Racine, Alfieri, and Goethe among the moderns.

**ELECTRIC FISHES.** The extraordinary modification of the peripheral extremities of nerves by which electricity is generated and discharged is found in four genera of fishes, and in no other class of the vertebrata. The best known of these fishes are the torpedo and the electrical eel; the former will be separately treated under its own name, and the latter, with two others for which there is no common name, in this article.—The electrical eel (*Gymnotus electricus*, Linn.), though apodal and eel-like in general appearance, differs from the eels in the completeness of the jaws, the presence of ribs, and the jointed fin rays; it has neither ventral nor dorsal fin; the anal reaches to the point of the tail, and like the pectorals is enveloped in a thick skin which conceals the rays; the skin is soft and scaleless; the head is oval and flat, the mouth furnished with broad lips, and opening not quite as far as under the eyes; the anterior nostrils are small tubes in a slight depression on the side of the

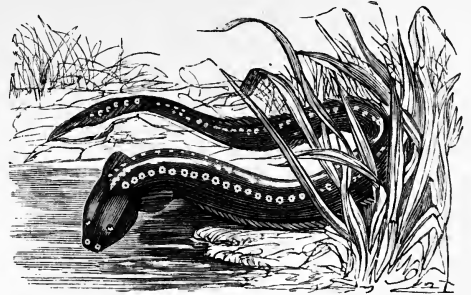

Electrical Eel (*Gymnotus electricus*).

lips; the posterior are behind and above them; lateral line distinct; about 50 pointed teeth on the upper jaw, and 60 on the lower, a second row of about six behind the middle of the upper ones, and four small teeth in two rows along the symphysis; the vent opens before the



branchial orifices, and behind it is a small opening and a slender papilla. The only species known inhabits the rivers of the northern parts of South America; it attains a length of 5 or 6 ft., and is brown and yellowish. The electric apparatus which has rendered this fish so celebrated occupies the space between the pectorals and the tail, for a large part of the lower bulk of the body; the organs are four in number, two on each side, the upper and larger organ being separated from the lower by a thin stratum of muscle and membrane, and the organs of one side are distinct from those of the other; the apparatus consists of an assemblage of membranous horizontal plates, nearly parallel and intersected by delicate vertical plates; the cells thus formed are filled with a glutinous matter; the septa, according to Hunter, are about  $\frac{3}{8}$  of an inch from each other, and one inch in length contains 240 cells, giving a very great surface to the electric organs. The system is abundantly supplied with nerves from the



*Malapterurus Electricus.*

200 pairs of ventral spinal nerves, but not from the lateral continuation of the trigeminal and vagus nerves from which the electric system of the torpedo is supplied. The electric eel seems to be a mere appendage to the anterior part of its battery for moving it about, as all the other organs are confined to a very small space, even the vent opening under the head; and the nerves supplying the electric organs are much larger than those sent to any sensory or motor organs. According to Humboldt, the South American Indians capture these eels by driving horses and mules into the water inhabited by them; the electric powers of the fish being exhausted on the quadrupeds, the former are harpooned and thrown on shore; the horses suffer greatly, many of them being killed by the electric discharges of the fish which glide beneath their bodies. By grasping the head of the eel with one hand and the tail with the other, painful and almost insupportable shocks were received in the experiments of Faraday. This fish is neither voracious nor fierce, but uses its battery to secure its prey, and to defend itself

from its numerous enemies.—The third electric fish belongs to the family of *siluridae*, and the genus *malapterurus* (Lacép.). The *M. electricus* (Lacép.) differs from the common siluroids in having no anterior dorsal fin nor pectoral spine; the skin is naked and scaleless; there is an adipose dorsal fin near the caudal; the ventrals are just behind the middle, and the anal occupies about half the distance between them and the rounded caudal; the body is stout, the tail thick, and the head short and conical; the lips are fleshy, with six barbels; five villiform teeth in each jaw, none on the vomer. The fish attains a length of 18 or 20 in., and is found in the Nile, Senegal, and other rivers of northern and central Africa; the color is cinereous or olive above, spotted and irregularly marked with black, whitish below; anterior nostrils tubular. The existence of a fish with benumbing powers in the Nile has been known for more than 300 years, but Geoffroy and Rudolphi were the first to give detailed descriptions of the electric organs. Valenciennes describes these as forming on each side of the body, between the skin and the muscles, two thin layers of spongy cellular tissue uniting together small lozenge-shaped cells filled with gelatinous fluid, and six or more fine longitudinal membranes; combining the structure of these organs in the torpedo and gymnotus, and receiving the nervous influence both from the lateral branch of the vagus and from the ventral branches of the spinal nerves. The shock given by this fish is comparatively feeble, the discharge taking place when the head is touched; no shock is felt when the tail is grasped, as the electric organs do not extend to this part; in giving a shock the tail is moved, as if the muscles were active. This fish is much esteemed as food. The Arabs call it *raash* (thunder).—The fourth electrical fish belongs to the order *plectognathi*, family *diodontidae*, and genus *tetraodon* (Cuy.). The upper and under jaws are divided by a median suture, so that they seem to have two teeth above and two below, incorporated with the jaws; in most of the species of the genus, the body, except the head and tail, is rendered rough by spines made erectile by the inflation of the skin, or naturally erect; but in the electric species (*T. electricus*, Paterson) the skin is destitute of spines, in conformity with the ascertained law that no electric fishes have either scales or spines; the body is brown above, yellow on the sides, sea-green below, and varied with red, green, and white spots. It attains a length of 7 or 8 in., and is found in the lagoons of the Pacific. Its electric powers are comparatively feeble.—The most characteristic feature of all these batteries is their enormous supply of nervous matter; the electric organs generate the electricity, which is rendered active by nervous influence. In the torpedo the shock is best received when one hand is placed on the back and the other on the abdomen of

the fish; in the gymnotus the intensity of the shock is in proportion to the length of the fish included between the hands; actual contact with the torpedo is not essential, as it is well known by the Neapolitan fishermen that the shock is felt when the water is dashed upon it, the electric current passing up along the stream, the circuit being completed through the earth to the ventral surface of the fish; the dorsal surface is always positive, and the ventral negative. That this is the same as common electricity has been shown by Matteucci and Faraday; it renders the needle magnetic, and decomposes chemical compounds; by it heat is evolved, and the electric spark is obtained. The exciting nerves terminate in loops, as in the muscular tissue, and they arise like motor nerves from the anterior tract of the cord; the reception and conveyance of impressions, and the voluntary act which results in the shock, are of the same nature and follow the same course as the muscular contractions; a division of the electric nerves at their origin arrests all voluntary shocks, but an irritation of the ends of the nerves in connection with the organ is followed by an involuntary electric discharge, just as an irritation of the end of a divided motor nerve in connection with muscle is followed by its contraction. The electric like the muscular power is exhausted by exercise, and recovered by rest; both are increased by energetic respiration and circulation, and both are exalted by the action of strychnine, which produces tetanic contraction of the muscles, and a rapid succession of involuntary electric discharges. The phenomena displayed by these fishes afford no ground for the opinion that nervous influence is identical with electricity; the former is no more identical with the latter than it is with muscular contractility; the contractility of the muscle resides in its fibre, and the electricity is generated in the battery of the fish; both are brought into play through nervous influence, but neither resides in or is a property of the nerves. The phenomena of heat, electricity, and phosphorescence within the animal body depend on chemical actions, which take place in the system just as they would in the chemist's laboratory, modified always by the mysterious vital principle. According to Faraday, the shock of the electrical eel is equal to that of 15 Leyden jars of 3,500 square inches of surface.

**ELECTRICITY**, the science which treats of the peculiar phenomena of attraction and repulsion exhibited when friction and other mechanical forces are applied to bodies, and of certain effects which accompany chemical decomposition or other change of physical state; or the phenomena that arise from the relation which bodies may bear to terrestrial and other magnetic lines, particularly when these are undergoing change in quantity or direction. The general science includes statical and dynamical electricity, or electric force in a state of rest or of motion. The former, being

usually developed by friction, at least for experimental purposes, is often called frictional electricity. The latter may be developed by chemical action, by heat, magnetism, and other forces; but in whatever way produced, it is always in the form of currents, and exhibits a constant manifestation of power. Statical electricity may also be obtained by greatly increasing the intensity of dynamical electricity, as will be shown in the articles **GALVANISM** and **MAGNETO-ELECTRICITY**. This article will treat of frictional electricity, while dynamical electricity, so far as it relates to the development of currents by chemical action, will be treated in the article **GALVANISM**. That part of dynamical electricity which relates to the development of magnetism by electrical currents, and of the development of electrical currents by magnetism, will be treated under the heads **ELECTRO-MAGNETISM** and **MAGNETO-ELECTRICITY**. The development of electricity by heat will be treated in the article **THERMO-ELECTRICITY**.—The word electricity is derived from the Greek *ἤλεκτρον*, amber, a substance described by Thales of Miletus six centuries before Christ as possessing the property, when rubbed with a piece of silk, of attracting light bodies; this he ascribed to the presence of a soul, which when excited left the body and brought the light bodies to it. Theophrastus and Pliny mention the power of amber to attract straws and dry leaves, and also the possession of the same property by the *lapis lincurius*, supposed to be the mineral tourmaline. The electricity of the torpedo was known to the ancients, as we learn from Pliny and Aristotle; or rather, it was known that the fish had the power of producing certain physiological effects, but their explanation, or the relation which they bore to the property of amber, was unknown. As regards the science of electricity, a record of the simple phenomena of attraction and repulsion is all that has been handed down to us by them, and but little knowledge of the subject was acquired until toward the end of the 16th century, when Dr. Gilbert of Colchester, England, made a series of experiments on account of which he has been called the founder of the science. This title, however, can scarcely be justly applied to any one individual, especially at that early day, when a few isolated facts, as yet unconnected with any mathematical law, were all that was known. Robert Boyle, while investigating other physical subjects, added several substances to the list of "electrics." Otto von Guericke, about the same time or a little earlier, made discoveries of still greater scientific value; for instance, that of electrical induction. Sir Isaac Newton also made some important investigations in electricity, and Sir David Brewster ascribes to him the invention of the glass globe electrical machine. Stephen Gray, a member of the royal society, between the years 1720 and 1736 made several discoveries in regard to the conduction of electricity. M. Du Fay of the

French academy was perhaps the first to approach the subject in a theoretical way. He found that all bodies were susceptible of electrical excitement by friction if they were insulated, and was the first to propose the theory of two fluids, which he termed vitreous and resinous. The results of the labors of other investigators will be mentioned in the descriptions of apparatus or experiments. The discoveries of Franklin and some further notice of static electricity will be found in the article LIGHTNING.—The ordinary phenomena of frictional electricity may be observed by taking a dry glass rod, rubbing it on a piece of dry silk, and presenting it to small scraps of paper or pieces of pith, when they will fly against the rod, and after remaining a short time, the length of which depends on the intimacy of contact and the nature of the light bodies, they will fly off with a sudden motion, as if repelled. Similar effects may be produced by using a stick of sealing wax, a material mainly composed of gum shellac, in place of the glass rod. It was supposed for a long time that only certain bodies were capable of becoming electrically excited, and they were called electrics, while those which did not distinctly manifest excitement under similar circumstances were called non-electrics. When the conduction of electricity was made the subject of investigation by Stephen Gray, it was found that all the so-called electrics were non-conductors, and that those which were termed non-electrics were conductors. This discovery led to the insulating of conductors and subjecting them to friction, when it was found that they also were readily excited. The division into electrics and non-electrics was thus found to be incorrect, and was abandoned, the fact being recognized that under proper circumstances all bodies are electrics. Bodies differ so greatly in the power of conducting electricity that they may be classed into conductors and non-conductors; but there are none which are perfect non-conductors except possibly dry gases. The following list of solids and liquids exhibits the conductors in the order of their conductivity, and the non-conductors in the inverse order, the best non-conductors being placed first:

## CONDUCTORS.

All metals,	Snow,
Well burned charcoal,	Living vegetables,
Plumbago,	Flax,
Concentrated acids,	Hemp,
Dilute acids,	Living animals,
Saline solutions,	Flame,
Spring water,	Moist earth and stones.
Rain water,	

## NON-CONDUCTORS.

Shellac,	Diamond,	Baked wood,
Amber,	Ebonite,	Porcelain,
Resins,	Gutta percha,	Marble,
Sulphur,	Silk,	Camphor,
Wax,	Wool,	Caoutchouc,
Jet,	Feathers,	Chalk,
Glass,	Dry paper	Oils,
Mica,	Leather,	Metallic oxides.

If an electrically excited insulated conductor is placed in contact with another conductor which is also insulated, a portion of its electricity disappears, and the two become equally excited. If the first body is large in proportion, it loses but little of its electricity; but if it be smaller than the other body, it parts with a proportional quantity; and if the difference is vast all sensible excitement disappears, as when communication is made with the earth, which is often called the common reservoir. Non-conductors may be used as insulators. Dry air is an excellent insulator; if it were not so, it would be impossible under ordinary circumstances to collect electricity upon any body, because it would be conveyed away as fast as generated. Damp air is a partial conductor, and therefore experiments in frictional electricity cannot be well performed during moist weather. It was for a long time observed that different bodies when electrically excited seemed to possess opposite states of electricity.

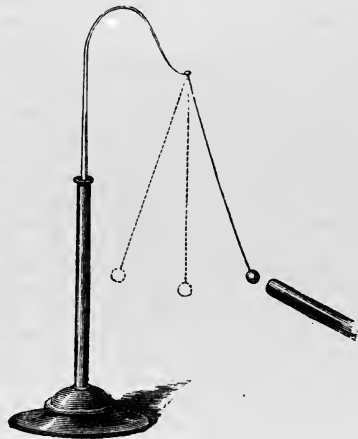

FIG. 1.—Attraction and Repulsion.

Thus, if a gilt pith ball be suspended by a silk thread, as in fig. 1, and approached by a glass rod which has been excited by friction with a piece of silk, it will be attracted to it; but as soon as contact is made it will be repelled, and the repulsion will continue as long as the ball retains its charge. If, however, a stick of excited sealing wax be brought toward it before its charge is lost, it will be attracted, and more powerfully than it was at first, by the glass rod. To explain this phenomenon different theories have been proposed, which are discussed in the article ELECTRO-MAGNETISM. In this article, for convenience of explanation, the existence of two fluids will be assumed, termed positive and negative, which in the natural state of bodies are supposed to be combined, but which are separated or decomposed by mechanical or some other force, and are moreover mutually attractive, but self-repulsive. There is no proof of a special electric fluid,

either compound or simple; but it may be that the luminiferous ether which most physicists now suppose to be the common medium for the transmission of light and heat will play an important part in a future theory of electricity. The fact that what is called the electric fluid cannot be discharged through a nearly perfect vacuum presents apparently a strong objection to the idea that the ether may be an electric medium; but this consideration does not affect the possibility that it may exert a controlling influence, and it is not improbable that the recent investigations into the molecular nature of bodies in relation to heat and light will lead to others by which the problem may at last be solved. With regard to the kinds of electricity which may be developed upon a body, it is found that it not only depends upon the body itself, but upon the body with which it is rubbed; thus, although glass in almost every instance collects positive electricity by friction, if the fur of the cat be used for this purpose it will be found to be negatively electrified. The surface also has much to do with the nature of the fluid which a given body may acquire; thus, if a piece of polished and a piece of rough glass be rubbed together, the former will be positively and the latter negatively electrified. If two silk ribbons are rubbed across each other, the one transversely rubbed will be negatively and the other positively electrified; and again, if two bodies of the same substance and having the same kind of surface, but differing in temperature, are rubbed together, negative electricity will be developed upon the warmer body. The kind of excitement a body may manifest also depends upon the color. When a piece of white is rubbed with a piece of black silk, the former acquires positive, and the latter negative electricity. The general deductions of Coulomb from numerous experiments are, that when two bodies are rubbed together, the one whose particles are least disturbed is more disposed to collect positive electricity. Other forms of mechanical action besides friction will develop statical electricity. Several minerals when pressed between the fingers exhibit free electricity. Calc spar, topaz, and fluor spar are examples, the first retaining its excitation for several days. According to the observations of Becquerel, the excitation is not perceptible while the pressure continues, but during the act of separation. Two similar bodies do not develop electricity when pressed together unless one is colder than the other, the colder body always becoming negative. Cleavage or the tearing asunder of laminae will produce electrical disturbance in minerals, card board, or other laminated bodies. Vibration develops electricity. A wire composed of iron and brass, connected with a galvanometer, on being made to vibrate so as to produce a musical sound, will cause a deflection of the needle. Statical electricity is also developed by heat; a familiar example is the attraction and repulsion

of ashes when tourmaline is placed in hot embers.—*Electrical Induction.* If a globe, C, fig. 2, supported upon an insulating pillar, and charged with positive electricity, be placed near one end of a cylinder, A B, also insulated, but not previously electrified, from which small gilt

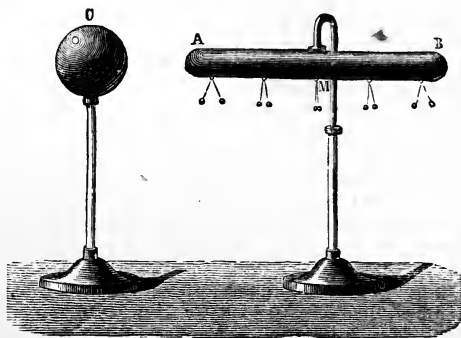

FIG. 2.—Electrification by Induction.

pith balls are suspended, the latter will be seen to separate, the separation being greatest at the two ends, while at a place midway no excitement will be manifested. It will be found that that portion of the cylinder nearest the globe will have negative and the further end positive electricity, the amount in either case diminishing from the ends to the place between where there is no excitement. The greatest divergence of the pith balls will be upon the end nearest the globe, and the point of no excitement will be nearer this than the other end. If the globe is removed to a considerable distance from the cylinder, the latter will assume its natural state, the excitation having been caused simply by a separation by induction of the combined fluid upon the cylinder, and without any abstraction of either positive or negative fluid. If, however, while the globe is near the cylinder, the latter be placed in communication with the earth, the positive electricity which is repelled to the further end will escape, and a corresponding quantity of negative electricity will flow in the contrary direction to the cylinder, and, being attracted by the positive fluid of the globe, will increase the charge upon the end nearest it. Then, if communication with the earth be interrupted and the globe removed, the cylinder will be charged with negative electricity, which will manifest itself in the separation of the pith balls, the divergence being now equal along the whole length of the cylinder. If the experiment is made with two cylinders, placed end to end, they will both become excited by induction, the induced electricity of one causing induction in the other. In this manner a number of cylinders may be electrified, but the excitation will become feebler in proportion to the departure from the globe. The ordinary explanation includes the idea that the action takes place at a distance, the non-conducting medium

between the excited globe and the cylinder being disregarded; but according to the researches of Faraday, the molecules of this intervening medium, which is called a dielectric because the electric action is propagated through it, become alternately positively and negatively electrified. This condition he called polarization of the medium, and to exhibit it experimentally he placed small fragments of silk in a vessel of turpentine, in the opposite sides of which two conductors were placed. Upon charging one of these, and connecting the other with the ground, the particles of silk immediately placed themselves end to end, forming a continuous chain from one conductor to the other. The influence of the dielectric is also shown by placing a plate of shellac between the electrified globe and the cylinder, fig. 2, when the latter will manifest more excitement than before, the divergence of the pith balls increasing. By using different substances as dielectrics, it will be found that each exerts a specific influence, the relative amount of which Faraday has termed specific inductive capacity. An experiment of Matteucci supports Faraday's theory. Several thin plates of mica were placed closely together, the terminal ones having metallic coatings. While in a state of excitation by induction the plates were removed one by one, and found charged, on one side with positive and on the other with negative electricity. If a pith ball be suspended by a linen or cotton thread, it will be more strongly attracted by an excited body than if suspended by a silk thread, because the linen or cotton thread will allow the electricity which is of the same kind as that of the excited body to pass away from the ball, while it becomes fully charged with the opposite kind. The silk thread, however, prevents this, and only allows the fluid which is of the same kind as that of the excited body to pass to the further side of the ball.—*Electroscopes*. These are instruments used for the purpose of detecting the presence of free electricity, and also its nature. The pith balls represented in fig. 2 are electroscopes, but they possess little delicacy. A much more efficient apparatus is formed by two strips of gold leaf placed together and suspended by a conductor, as in Bennet's gold-leaf electroscope, fig. 3. It is protected by a glass cover, within which, at either side, project from the bottom two conductors for the purpose of preventing the rupture of the leaves if they should diverge rapidly from a strong charge. A body having only a small amount of electricity, upon being held near the knob of the conductor, causes induction and separation of the leaves. In order to ascertain the kind of electricity any excited body may have, it is first brought near the knob; this is then touched with the finger to bring it in communication with the earth, and thus permit the escape of the electricity which is of the same kind as that of the body to be tested. Then, while the excited body is near, the finger is

removed from the knob, the gold leaves and the conductor being thereby again insulated. The instrument is now charged with electricity of an opposite kind to that of the body, the presence of which is manifested by a divergence of the leaves. The body to be tested is

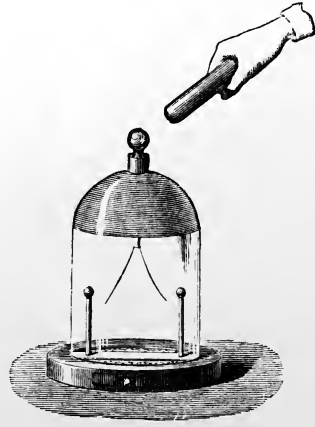

FIG. 3.—Bennet's Gold-leaf Electroscope.

now removed, and a glass rod that has been rubbed by a piece of silk is brought near the conductor. If the divergence of the leaves increases, it will indicate the presence of positive electricity, because the positive electricity of the glass repels that of the same kind from the knob to the leaves. If, on the contrary, the approach of the excited glass rods causes a diminution of divergence, it will show the presence of negative electricity, because it will be attracted from the leaves to the knob.—*Electrometers*. For the purpose of ascertaining the intensity with which a body is charged, and also the laws of electrical attraction, an instrument was invented by Coulomb, called Coulomb's torsion balance electrometer, represented in fig. 4. Its essential parts consist of a very fine metallic wire, weighing about one tenth of a grain to the foot, which is held in a cap at the top of the apparatus, and supports a delicate needle of shellac in a horizontal position at its lower end. This shellac needle has a small gilt ball, *g*, at one extremity, which being insulated may be made to receive, and for a short time to retain, a quantity of electricity. Another rod of shellac, *f'*, is so adjusted in the cover of the large glass cylinder that the small gilt ball *g'* which it carries, and which is of the same size as the ball *g*, may be passed down and held at a level with the latter. If now the horizontal needle *f* is so placed that the ball *g* may be touched by the ball *g'*, and the latter is charged with electricity and introduced, it will deliver to the former half of its charge, and the two will be mutually repelled, the repulsion being measured by the amount of torsion of the suspending wire, which may be ascertained by

means of a circular scale marked upon the circumference of the cylinder, and another suitably adjusted at the upper end of the small cylinder from which the wire is suspended. The cap at the top may be turned to increase the force of torsion, which is in proportion to the angle, and bring the balls nearer together; and it will be found that when the distance has been reduced to one half, the angle of torsion will be four times as great. It must be remembered, however, in making the calculation, that the actual distance between the balls is measured by the chord of the arc, and not by the arc itself. With this instrument Coulomb demonstrated the two following laws: 1. The force of attraction and repulsion between two electrified bodies is in the inverse ratio of the squares of their distance. 2. The distance remaining the same, the force of the attraction and repulsion between two electrified bodies

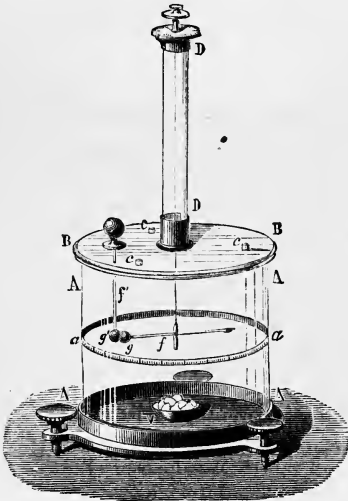

FIG. 4.—Coulomb's Torsion Balance Electrometer.

is directly as the product of the quantities of electricity with which they are charged. It is a natural conclusion that when a body is electrically excited, that is, when it contains free statical electricity, it resides upon the surface, being held there by the resistance of the insulating air and the self-repulsion of the fluid; and such a conclusion is borne out by experiment; but in the case of currents the capacity of a body depends upon the area of its cross section, a hollow wire not being so good a conductor as a solid one. If a hollow, insulated globe, fig. 5, having an aperture, is charged with electricity, and a small disk of gilt paper, called a proof plane, is carried by means of an insulating handle into the globe and applied to its interior surface, it will be found upon withdrawal to contain no free electricity. Faraday used a wire-gauze cylinder in place of the globe. It rested upon an insulated metal plate, which being charged of course supplied electricity to

the cylinder, but it all resided upon the exterior, no trace being found on applying the proof plane to the interior. Coulomb's torsion electrometer may also be used to demonstrate the same condition; for if a solid and a hollow sphere of the same diameter be brought

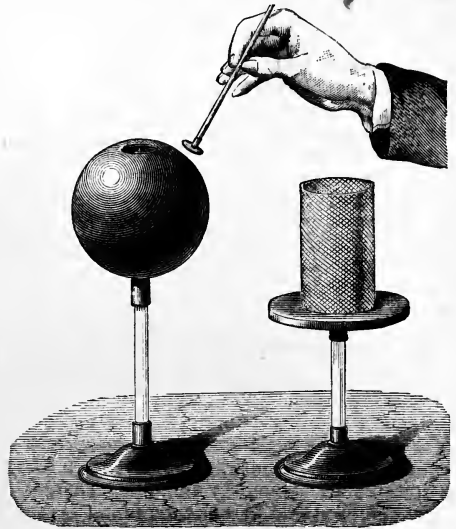

FIG. 5.—Proof Plane and Hollow Sphere.

together, one having free electricity, the charge will be equally divided between them. In consequence of the self-repelling force of the electric fluid which thus causes it to reside upon the exterior of bodies, it will be distributed in equal quantities over the surface of a sphere; but upon an ellipsoid or an elongated cylinder it will be greatest at the ends, and if these be quite acute the tension will become so great as to cause it to be discharged in a current. A disk also contains nearly all the charge at the circumference, as may be shown by the use of the proof plane and Coulomb's torsion electrometer, substituting the proof plane in place of the gilt ball in the carrying rod. An exception to the rule that statical electricity is confined to the exterior of a body is when an insulated electrically excited body is placed in the interior of a hollow conductor. In this case the excited body will induce upon the interior surface of the conductor a charge of opposite electricity; and if the conductor be insulated, an equal quantity of the same kind will be repelled to the outside. Again, if a conducting body be suspended by a wire connected with the earth inside of a hollow, charged, insulated conductor, it will become charged by induction with electricity opposite to that of the hollow conductor, a part of the charge of the latter being at the same time brought to its inner surface also by induction. If, now, the inner body be insulated and lifted out by a silk thread attached to the wire, it will retain its charge of opposite

electricity to that of the hollow conductor, but the electricity which existed upon the internal surface of the latter while the conducting body was inside will now return to its external surface. In fact, the two bodies are related to each other in a manner similar to the conductor and cylinder in fig. 2, so that the exception to the rule is more apparent than real. An electrified insulated body after a time loses its electricity; this is called dissipation of charge, and takes place partly along the supports and partly through the air. Coulomb found that, other circumstances remaining the same, the rate of loss is simply proportional to the charge, so that at equal intervals of time the charges form a decreasing geometrical series, following a law similar to Newton's law of cooling.—*Electrical Machines.* The first electrical machine was invented by Otto von Guericke, who was also the inventor of the air pump. A ball of sulphur turned on an axis was electrified by friction with the hand, receiving negative electricity, while the positive flowed to the earth through the person. Sulphur was afterward replaced by resin, and for this the English philosopher Hawksbee substituted a cylinder of glass. The hand was used as a rubber in all these, the cushion rubber made of horsehair, covered with silk, being introduced by Winckler in 1740. About the same time it is said that Boze, another German philosopher, used an insulated cylinder of tin. In 1760 Ramsden replaced the glass cylinder by a circular glass plate. Fig. 6 is a modification of Ramsden's machine in use at the present time. Between the two supports in which the glass wheel turns, and near its upper and lower edges, are two pairs of cushions, usually made of leather stuffed with horsehair and

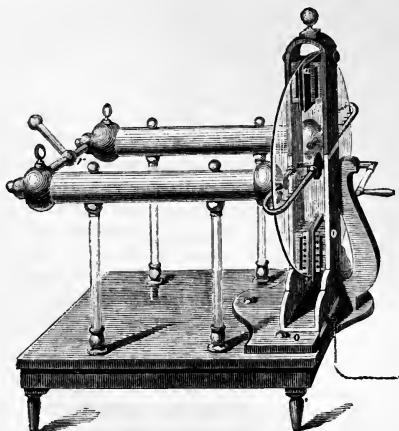

FIG. 6.—Ramsden's Plate Electrical Machine.

coated with bisulphide of tin or some amalgam, mixed with grease, as Kienmier's amalgam, which is composed of one part of zinc, one of tin, and two of mercury. These cushions are the rubbers for producing friction, and are con-

nected with the earth by means of a metal chain or rod. Two large hollow cylinders of brass, C C, with globular ends, each supported by two glass pillars, constitute the reservoir for receiving the electricity, which in this case is positive. They are called the prime conductors, and are supplied with U-shaped rods of metal, furnished with points along their sides called combs, for the purpose of receiving the electricity from the glass plate, the arms of the U being held upon either side. The other ends of the conductors are connected by a rod,  $r$ , from the middle of which projects another short rod terminating in a knob for delivering the spark. The action of the machine is as follows: When the plate is turned friction decomposes the fluid, positive electricity going to the glass and negative to the rubbers. The positive electricity of the plate attracted by the combs, passes to the prime conductor, while the negative upon the latter passes in a contrary direction to the plate, which in turn delivers it to the rubbers. The rubbers in consequence of their connection with the earth, receive positive electricity, which is powerfully attracted by the negative they contain, the union being again destroyed by friction and the positive fluid delivered to the prime conductor, where it collects until the tension becomes greater than the confining force of the air. It is then spontaneously discharged in sparks and jets, with a crackling and hissing noise, unless taken off by a conducting body. Upon the two-fluid theory it is supposed that as much of negative fluid passes in one direction as of positive in the opposite; so that a body always contains the same amount of electricity, either of one or of both kinds. Some machines, like that of Prof. Nairne, which employs a glass cylinder, are constructed with two conductors, one connected with the rubbers and the other with the points which receive the fluid from the cylinder. By connecting the positive conductor with the earth, and insulating the rubbers, negative electricity may be obtained. A convenient method is to mount the prime conductor upon an independent stand, and connect it at pleasure either with the points or with the rubbers. A great variety of forms of machines may be constructed, and the prime conductors may be made to receive their charge either by conduction from the plate or rubbers, or by induction. Of the latter kind, one invented by Holtz of Berlin, in 1865, remarkable for its great power, is represented in fig. 7. A circular glass plate,  $a$ , is fixed in an insulating frame. In opposite sides, near the circumference, are two large orifices, which are partly covered at the back by two bands or armatures of thick paper,  $f f'$ , having points projecting in the opposite direction to that of the motion of a second glass plate,  $b$ , somewhat smaller than  $a$ , and made to revolve very near it. Opposite the face of the movable plate, which has no orifices, there are metal combs,  $p p'$ , con-

nected with insulated conductors which terminate in adjustable knobs, *m* and *n*. An orifice in the centre of the fixed plate gives passage to the axis of the movable one, which can be rapidly rotated by a system of band wheels. The machine is started by bringing the knobs *m* and *n* of the conductors together and elec-

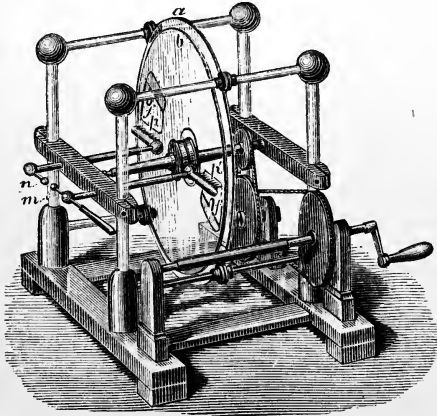

FIG. 7.—Holtz's Electrical Machine.

trifying one of the armatures, say *f*, by holding against it a plate of ebonite which has been negatively excited. After a few turns of the plate both armatures become highly charged with opposite kinds of electricity, *f*' becoming positive, and if the knobs are separated a stream of sparks will pass from one to the other. By increasing, within a certain limit, the distance between the knobs, the sparks become larger and less frequent; but beyond this limit, which depends upon the insulation and working order of the machine, the sparks will no longer pass, and unless the knobs are quickly brought together the machine will cease to act. The following is a brief explanation of its action. The negative electricity of the first armature tends to repel the same fluid in its vicinity, and to attract the opposite; consequently negative electricity flows from the face of the movable plate to the points of the comb, while positive electricity is discharged by the comb upon the plate. This will cause the comb of the second conductor, which at the commencement, as has been said, is in connection with the first, to become negative, while each portion of the glass plate will pass from the first to the second comb positively electrified. When successive portions of the plate thus charged arrive opposite the second armature, the latter, through its point, discharges negative electricity upon the plate and receives positive in return, thus becoming positively charged. Positive electricity from the face of the plate also passes to the second comb, and the latter discharges negative electricity upon the plate, which then passes on to the first armature and comb negatively electrified. Therefore the comb will dis-

charge positive electricity on and receive negative from the plate, and the armature will also receive a higher negative charge from the other side of the plate, because the latter is charged with higher tension. The effect is to cause the plate to leave the first comb more highly positive than it was the first time, and on again coming opposite the second armature to increase its positive charge. Both armatures become thus in a short time highly charged with opposite electricities, whose tension is only limited by the degree of insulation. A strong current of positive electricity, it will therefore be seen, is constantly passing through the conductors from the second to the first comb, and a corresponding current of negative electricity from the first to the second comb; and when the knobs of the conductors are separated the electricity will leap from one to the other. It is moreover evident that the action of the machine requires that each part of the movable plate be charged with electricity of an opposite kind to that of the armature it leaves, and of the same kind to that of the one it approaches. This condition, however, cannot continue if the conductors are so far separated as to prevent communication, or are beyond striking distance, because there would then simply be two armatures in opposite electrical conditions, with a moving plate passing from one to the other and gradually equalizing the charge. The inventor has recently modified this machine by placing the plates horizontally and turning them in opposite directions, as represented in fig. 8. Neither plate has openings, but two combs are placed above the upper plate opposite each other, and two others below the lower plate, at right angles to the upper ones. Each of the upper

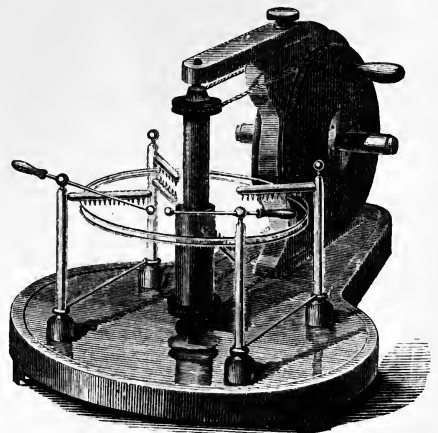

FIG. 8.—Holtz's Machine with Horizontal Plates.

conductors is connected with one of the lower, so that there are only two conductors. The machine is started by holding for a short time an excited plate of ebonite opposite one of the combs. Sometimes, as in the figure, a third



upper comb is placed above one of the lower combs, which appears to increase the power. In both forms of the machine work is expended in turning the plates in opposition to electrical attractions and repulsions, by which mechanical is converted into electrical energy. It will always be found difficult to obtain good results with electrical machines in damp weather. By warming the glass insulators, however, and frequently rubbing them with a warm dry cloth, their non-conducting property may be in a degree preserved. The Holtz machine is more sensitive to moisture than the ordinary kinds.—Other apparatus besides the ordinary machine are employed to develop statical electricity, the electrophorus of Volta being used with advantage in some experiments. It usually consists of a cake of resin about 1 in. thick, represented in fig. 9, resting upon a metallic base called the sole, and having resting upon it a metal disk with a rounded edge, and of less diameter than the resinous cake, furnished with an insulating handle. A good material for the resinous cake is composed of ten parts of shellac and one of Venice turpentine. Resin is better than glass or ebonite, because it does



FIG. 9.—Electrophorus.

not so readily condense moisture on its surface, and this little instrument requires to be in excellent condition to yield satisfactory results. In making experiments with the electrophorus the resinous cake is whipped with a catskin or rubbed with fur, which excites it negatively, and the metal disk is then laid upon it; this therefore has its natural fluid decomposed, the positive being drawn to the under and the negative repelled to the upper surface. The disk is now touched with the finger, by which it becomes positively charged from the earth, and if removed by the insulating handle will yield a spark; an operation which may be repeated several times before the resinous cake loses its charge.—The hydro-electric machine of Sir William Armstrong, which is said to have been discovered by accident, consists of a wrought-iron plate boiler, fig. 10, standing upon four glass legs. It is about 5 ft. long by 2 ft. in diameter, provided with a gauge, O, to show the height of water. A stopcock, C, when opened allows the steam to pass through a number of tubes in the box B,

containing cold water for cooling the steam. The ends of the tubes are furnished with jets whose construction is such as to increase the friction, and the jets are lined with hard wood, as shown in the figure at M. A metal plate, P, armed with points, collects the electricity, which is ordinarily positive, and conveys it to the prime conductor, D. There

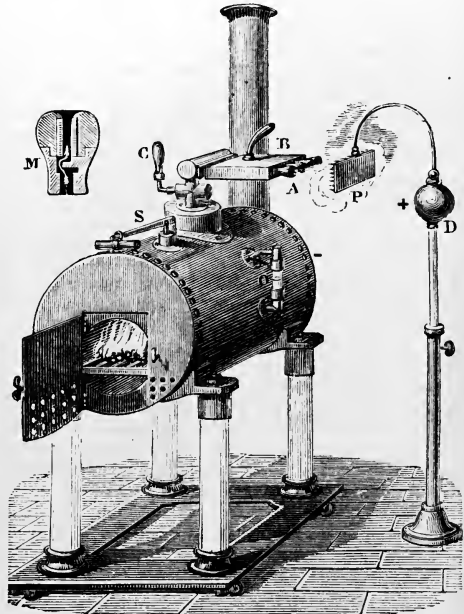

FIG. 10.—Sir William Armstrong's Hydro-electric Machine.

should be a pressure of several atmospheres in the boiler, and the water should be pure, the presence of a saline solution in the escape tube being sufficient to prevent development of electricity. By changing the material of which the jets are made the kind of electricity may be varied. If a small quantity of oil of turpentine is introduced into the boiler, the steam will become negatively and the boiler positively electrified. The generation of electricity by this machine was at first attributed to condensation of steam, but Faraday showed that it was caused by the friction of minute globules of water passing through the jets. Experiments are made with the ordinary glass-plate machine, represented in fig. 6, in the following manner: Let the rubbers be connected with the earth, the surface of the machine, especially the insulating supports, having been well rubbed with a warm dry cloth. If now the glass plate is turned briskly by the winch, on presenting a knuckle to the prime conductor induction takes place, the knuckle becoming charged with negative electricity. As soon as the tension is sufficient to overcome the resistance of the air, the fluids combine with a sharp report and a spark, a stinging sensation being felt in the knuckle. The spark will be

seen to better advantage if the room is darkened. By employing a hollow metal globe five or six inches in diameter, held by a glass handle, longer sparks may be obtained, as a greater quantity of negative electricity will be retained upon it before this discharge takes place. When the distance is short the spark is usually straight; when greater, it becomes curved, with branches or forks; and when considerable, say a foot, in large machines, it takes a zigzag course like that of lightning. When the air is dry and the machine working well, a hissing sound is heard, and in the dark luminous brushes are seen to issue from projecting parts of the conductor, and it will be found that the escape of positive electricity gives larger brushes than negative. Brilliant sparks will often leap across the plate



Fig. 11.—Spark in Rarefied Air.

between the cushions and the conductor, when the fluid is not otherwise taken away. By passing the spark through rarefied air and other gases various pleasing and curious effects are obtained. An apparatus called the electric egg, fig. 11, is often employed for this purpose. It consists of a glass globe with a cap at either end, through which passes a metal rod with a knob upon the interior extremity. The upper rod is made to slide so that the distance between the two knobs can be regulated at pleasure. Through the lower there is an opening provided with a stopcock, which may be screwed to a stand or to the plate of an air pump. When the egg is filled with air the spark has the ordinary appearance, but when partially exhausted it passes more readily, generally presenting the form given in the figure, the negative knob being usually surrounded by a violet halo, while the positive one exhibits a purple or a deep crimson. As the air becomes more rarefied the resistance to the discharge diminishes, and the brilliancy of the spark decreases, unless a nearly perfect vacuum is obtained, when no discharge will take place, as has been shown by Gassiot. These experiments are advantageously performed with the Holtz machine

by connecting the two poles with the two knobs of the egg, or other apparatus. The color of the spark depends on the gaseous medium and on the material of the conductors. When the spark is strong a portion of the conductor appears to be volatilized, from the fact that examination with the spectroscope reveals bright lines denoting the presence of metallic vapor, which are characteristic. When the spark is weak the influence of the gaseous medium is readily observed, nitrogen producing a blue, hydrogen a red, and carbonic acid a green color. The old electricians devised many pieces of apparatus for making curious and pleasing experiments, such as tubes, globes, and plates of glass, having small disks of tin foil placed at regular distances, distributed in spiral and other forms, so that when a spark was passed through the system it would be multiplied and exhibit illuminated figures. A person standing upon an insulated stool, and connected with the prime conductor, will become electrically excited, and sparks may be taken from the face or hands, or through the clothing, the resistance offered by the latter often causing the discharge to be quite loud and attended with a smart sting. The hair of the insulated person, if not too long, will stand upon end, and if dry each hair will be separate. A set of radiating arms like the spokes of a wheel, having their points bent in one direction, balanced upon an upright pointed rod supported by the prime conductor, fig. 12, will revolve when the machine is in action; an effect caused by the repulsion between the electricity of the points and that of the adjacent air which has been charged by them. A point placed upon the conductor, as in fig. 13, will create a current of air which may be felt by the hand or made manifest by placing a candle before it.—A phenomenon usually accompanying the passage of a stream of electricity from a point, or of the spark, is the conversion of a portion of atmospheric oxygen into its allotropic condition, ozone, which is easily perceived by the sense of smell. The conversion is supposed to be

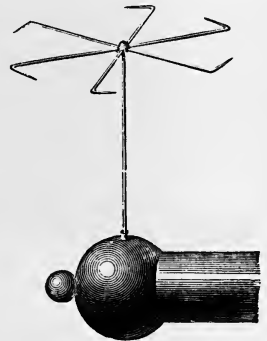

Fig. 12.—Revolving Points.

fig. 12, will revolve when the machine is in action; an effect caused by the repulsion between the electricity of the points and that of the adjacent air which has been charged by them. A point placed upon the conductor, as in fig. 13, will create a current of air which may be felt by the hand or made manifest by placing a candle before it.—A phenomenon usually accompanying the passage of a stream of electricity from a point, or of the spark, is the conversion of a portion of atmospheric oxygen into its allotropic condition, ozone, which is easily perceived by the sense of smell. The conversion is supposed to be

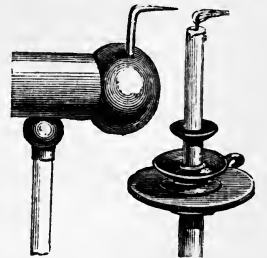

Fig. 13.—Current shown by means of a Flame.

produced by a rearrangement of the atoms of the oxygen molecules in consequence of vibrations communicated by the electric force.—*Duration of Spark.* The duration of the electric spark was measured by Wheatstone in 1835 by means of a rotating mirror. Let  $m n$ ,

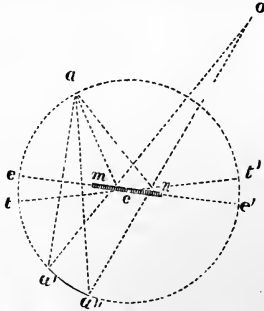

FIG. 14.—Duration of Spark.

fig. 14, represent a section of a mirror revolving on an axis  $c$ . A spark at  $a$  will be seen from  $o$  in the position of  $a'$  when the surface of the mirror is in the plane  $e e'$ , and in the position  $a''$  when the surface of the mirror is in the plane  $t t'$ . An instantaneous spark would appear as a point; that it has duration is proved by its having the appearance of a line. Wheatstone estimated this duration to

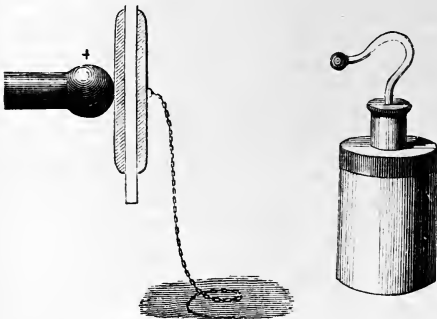

FIG. 15.—Condenser.

FIG. 16.—Leyden Jar.

be  $\frac{1}{74,000}$  of a second. Experiments afterward made by Feddersen, and published in 1858, showed that the spark when analyzed consisted of two parts, viz., a whitish streak and a red tail; and that, exclusive of the red tail, it was prolonged by increasing the charge, and also the area of the coating. A further and more careful analysis of the spark from a Leyden jar, connected with a Ruhmkorff coil, has recently been made by Prof. O. N. Rood of Columbia college, in which he found the duration varied with the substance of the electrodes, and also with the striking distance and the area of coating. By the use of nicely adjusted apparatus he succeeded in producing sparks from platinum electrodes at a distance of one millimetre, whose duration was ascertained to be a little more than 41 billionths of a second.

An account of the experiments may be found in the "American Journal of Science" for September, 1869, September, 1871, and September, 1872.—*Condensers.* The condensation of electricity is usually effected by separating two conductors by a plate of glass or other non-conductor, and connecting one of them with the earth in the manner shown in fig. 15. A plate of glass or other non-conductor employed in this manner is called a dielectric. On bringing the insulated conductor in connection with an electrified body, as the prime conductor it becomes charged with one kind of electricity, while the conductor on the other side of the plate becomes charged with the opposite kind, drawn from the earth and held by the powerful attraction exerted through the non-conductor, or dielectric. Charges of enormous intensity may be obtained by these means. The Leyden jar, fig. 16, said to have been in-

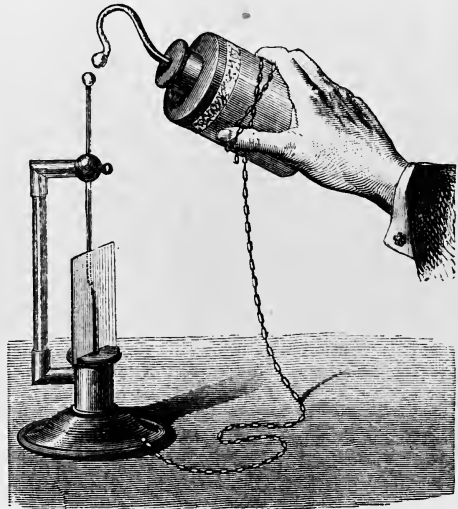

FIG. 17.—Puncture of Card.

vented by Cuneus, a pupil of Musschenbroek of Leyden, in 1746, is constructed upon this principle. It consists of a glass jar coated with tin foil upon both inner and outer sides to the same height, space enough being left to avoid union of the opposite fluids across the edge. To the mouth is fitted a cover of baked wood, through which passes a rod carrying a chain which lies upon the inner coating, and having a knob upon its upper end by means of which connection between the outer and inner coatings may be readily made by a jointed discharger provided with a glass handle. The Leyden jar is advantageously used in making experiments requiring great intensity of charge. Its condensing capacity depends, within certain limits, upon the thickness of the glass, it being in the inverse proportion of the distance between the two coatings, and upon the extent of their surface. Its power may there-

fore be increased by placing a number of jars together on a sheet of tin foil or other good conductor, and connecting all the inner coatings by rods or chains passing from knob to knob. Such an apparatus is called a Leyden battery, and it may be charged, like a single jar, with the ordinary machine, by connecting one coating, it is not very material which, with the prime conductor, and the other with the earth or with the rubbers. In charging with the Holtz machine, one conductor is connected with the inner and the other with the outer coating. If a piece of card board is placed between two points, as in fig. 17, and one of them, say the lower, is connected with the outer coating of a charged Leyden jar, on bringing the knob of the jar near the knob connected with the upper point, the fluid will leap across the spaces between the knobs as well as between the points, but in passing from point to point it will pierce the card board. The hole will be found burred on both sides in consequence of the repulsion of the particles of paper, and its location is also nearer the negative than the positive point, unless placed in an exhausted receiver, when it will be nearer the middle. By using a battery of several jars the fluid may be made to pierce a hole through a thin plate of glass. It may be remarked that if the experiment fails the first time, subsequent ones with the same piece of glass will scarcely succeed as the fluid will almost invariably follow the course it first took. Gunpowder, turpentine, and combustible gases may be fired by means of the Leyden jar or battery, and metallic wires may be fused if they are small enough to offer sufficient resistance to the passage of the fluid. After a Leyden jar is discharged, if a short time is allowed to elapse, and the coatings be again brought near together, a second or a third smaller spark may be obtained. The electricity thus remaining after the first discharge is called the residual charge, and, according to Faraday's experiments, it is caused by the gradual penetra-

tion of the electric fluid into the substance of the glass dielectric, and accords with his opinion that conductors differ only in degree. The charge of a Leyden jar or battery may be estimated by means of an apparatus called a unit jar. Lane's unit jar or electrometer is represented in fig. 18. The jar or battery whose charge is to be measured is placed upon an insulated stand, and the inner coating connected with the prime conductor. If no connection were made between the external coating and the earth, it is evident that the jar could not be charged. The connection is made through a small Leyden jar, *c*, whose inner coating is connected with the outer coating of the first jar or battery, while its outer coating is connected with a rod carrying a knob, which is brought near to the knob connected with the inner coating. When the small jar becomes sufficiently charged the fluid will leap across the space between the two knobs, which is called the striking distance, the amount being quite uniform for the same distance, and called the unit of measurement. By using the same instrument similarly adjusted a comparison of charges of different batteries, or of the same battery at different times, may be made. The physiological effects of the discharge of a Leyden jar are similar to those of lightning. A small jar of only a few inches surface is capable of giving a powerful shock when passed through the arms, and a large jar or a battery strongly charged is capable of giving a shock sufficient to produce death.—Frictional electricity is sometimes used in medicine, and it may often be employed with advantage, either by passing small repeated shocks by means of a small unit jar through the body or limbs, or the patient may be insulated and have sparks drawn from him; but the galvanic battery, employed alone or with electro-magnetic currents, may generally be used with more certain results. The subject will be noticed in the article **MEDICAL ELECTRICITY**.—Among the numerous works that have been published on electricity are the following: *Æpinus, Tentamen Theoriæ Electricitatis et Magnetismi* (4to, St. Petersburg, 1759); Franklin, "Experiments and Observations on Electricity, made at Philadelphia in America" (London, 1769); Haly, *Exposition raisonnée de la théorie de l'électricité et du magnétisme* (Paris, 1787); Tiberius Cavallo, "A Complete Treatise on Electricity" (3 vols. 8vo, London, 1795); Faraday, "Experimental Researches in Electricity" (London, 1849-'55); Sir W. Snow Harris, "Electricity, Magnetism, and Galvanism" (London, 1867); Deschanel, "Natural Philosophy" (New York, 1873); Ganot, "Physics" (New York, 1873); Fleming Jenkin, "Electricity and Magnetism" (New York, 1873); J. Clerk Maxwell, "Electricity and Magnetism" (London, 1873).

**ELECTRIC LIGHT**, the light produced by a current of electricity in passing through a resisting medium, as a gas or a small wire. Like solar light, it also produces the combination of chlorine and hydrogen, acts chemically on chloride of silver in the photographic process, and when viewed through a slit in a screen by a prism it presents a spectrum crossed by very bright lines, differing in character with the substance of which the electrodes are formed, and with the gases through which

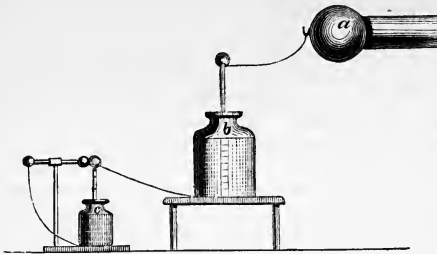
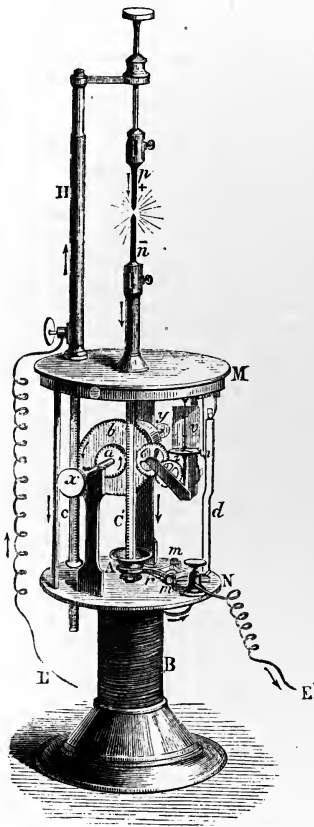

FIG. 18.—Lane's Unit Jar.

tion of the electric fluid into the substance of the glass dielectric, and accords with his opinion that conductors differ only in degree. The charge of a Leyden jar or battery may be estimated by means of an apparatus called a unit jar. Lane's unit jar or electrometer is represented in fig. 18. The jar or battery whose charge is to

the sparks are passed. Hence the electric light becomes an important means of chemical analysis. With carbon the lines are remarkable for number and brilliancy; with silver they are intensely green; with lead, of a violet tint; and so on, varying with each different substance. Being producible in nitrogen, the electric light is not the effect of combustion, but of the intense heating and volatilization of ponderable matter. We say ponderable matter, because the electric spark cannot pass through a vacuum. A most intense and steady electric light is evolved be-



Duboscq's Regulator.

tween two points of coke, forming the poles of a battery, and brought into close proximity. From its great brilliancy and cheapness this light would seem to be well adapted for illumination, especially for lighthouses, and if introduced into mines it would apparently prove the most powerful illuminating agent, without tending, like other lights, to contaminate the purity of the air. But this light is deficient in the most penetrating ray of the spectrum, the red, and therefore does not produce the effect which was anticipated from it in the way of

penetrating fog. It is also so very intense, a large quantity of radiation being given off from a single point, that the eye is dazzled, and vision becomes much more indistinct than with the same quantity of light given off from a lamp with large concentric wicks. It may however be used with much success in various optical experiments. But in this application one of the principal obstacles to be overcome is the continual separation of the charcoal or coke points as these are slowly consumed. Caution is required in experimenting with this light when of great intensity; a single moment of exposure to the radiation from a battery of 600 couples produces violent headache and inflammation of the eyes. For the purpose of illumination it is necessary to have the light constant and uniform. The galvanic current as well as the distance between the carbon points must not change; and as the carbon slowly wears away, an apparatus is required to move them toward each other. The engraving represents Duboscq's regulator. Both the points move, but with unequal velocities, so as to keep the light at a fixed point, the positive point wearing away twice as fast as the negative. The motion is produced by a coiled spring in the drum placed on the axis  $xy$ . This turns two wheels,  $a$  and  $b$ , which move the racks  $C$  and  $C'$ , and by these the carbon points, one up and the other down. The current passes into the apparatus by the wire  $E$  and leaves it by  $E'$ , without however passing through the rackwork, which is insulated. Before leaving it passes through the coil  $B$ , surrounding a piece of soft iron, which is a magnet while the current passes, and constitutes the regulator. When the carbon points approach too near the strength of the magnet is increased, and by means of a lever the rod  $d$  is made to turn in such a way as to stop the motion of a series of toothed wheels which are moved by the drum. In this way the motion of the points is arrested until they have wasted enough to diminish the current, and consequently the strength of the magnet, when the stop is relieved, and the motion continues.

**ELECTRO-MAGNETISM**, that science which treats of the development of magnetism by means of voltaic electricity. In our article on electricity we have given an exposition of the facts of this branch of science, independent of any hypothesis as to the causes of the phenomena; but the present topic cannot be treated satisfactorily without giving some idea of the generalizations which have been invented to explain the phenomena, and to express the laws of their mutual connection and dependence. It must be recollected that science does not consist in an accumulation of facts, but in a knowledge of principles, and it is impossible to arrive at a full comprehension of these principles without expressing them by means of some hypothesis from which logical deductions can be made, which will enable us at any time, independently of mere memory, to

say what result will be produced when the conditions are known, or in other words, which will not only present to us the relations of known phenomena, but enable us also to predict the occurrence of those which have not been observed. Without hypotheses of this kind no extended and definite progress can be made in science. It should, however, always be borne in mind that they are the provisional expressions of the generalizations of our knowledge at a given time, and that we must hold ourselves in readiness to modify or even abandon them when we meet with facts with which they are decidedly inconsistent. Two hypotheses have been proposed to account for the phenomena of electricity: one, that of Du Fay, known by the name of the theory of two fluids, and the other by that of the Franklinian, of one fluid. According to the first, all bodies are pervaded by two elastic fluids, the atoms of each repelling those of the same kind and attracting those of the opposite kind. When the two fluids are together in equal quantities in the same body, they neutralize each other; but when separated by friction or other means, their attractions and repulsions are manifested by various electrical phenomena. The second hypothesis supposes that all the electrical phenomena are produced by the disturbance of one highly elastic fluid, which pervades the earth and all material bodies, and which is able to move with various degrees of facility or not at all through the pores of substances of different kinds of gross matter, which are hence considered either conductors or non-conductors; that the atoms of this fluid repel each other with a force varying inversely as the square of the distance; that the atoms of the same fluid attract the atoms of gross matter, or some ingredients in it, with a force varying in accordance with the same law; and that the atoms of gross matter devoid of electricity tend to repel each other with a force inversely as the square of the distance. When any body has so much electricity combined with it that the self-repulsion of its atoms is just balanced by the attraction of the same atoms for the unsaturated matter, then the body is said to be in its natural state. So long therefore as all portions of space contain their natural share of the fluid, no electrical phenomena are exhibited; but if, by means of friction, chemical action, heat, or other agencies, together with the interposition of partial or non-conducting substances, the electricity is accumulated in one portion of space, and rendered to the same amount deficient in another, then two classes of phenomena are manifested: 1, those called statical, such as induction and the consequent attraction and repulsion of light bodies, due merely to the accumulation or deficiency of the fluid; 2, dynamical, or those which arise from the transfer of the fluid from the place where it is redundant to that where it is deficient. Franklin's claims to philosophical genius rest particularly upon his con-

ception of this theory of electricity, which, with slight modifications and additions, is still sufficient to express the connection and relation of the multiplicity of facts which have been discovered since his day. However different the two theories at first sight may appear, their mathematical expression and the deductions from them do not differ, provided that we adopt the modification of the latter proposed by *Æpinus* and *Cavendish*, that matter devoid of electricity repels matter; an assumption not inconsistent with the attraction of gravitation and chemical action, since we may refer even these to the same cause. The theory of *Du Fay* was generally adopted by German and French savants, because it was first discussed by them in a mathematical form. The theory of *Franklin* was afterward developed mathematically, and with the modifications we have mentioned is, we think, more readily applicable to the facts of the present state of the science than the other. It follows from the theory of *Franklin* that if electricity be communicated to a sphere of conducting matter, all the fluid will be found at the surface, because each atom repels the other, and the state of equilibrium will be that of an equal distribution at the circumference; the atoms are prevented from flying into space by the non-conducting medium of air in which the globe exists. In like manner it follows from an application of the law of attraction inversely as the square of the distance, that when a body has less than its natural share of electricity the deficiency must exist at the surface. In charged conductors of elongated forms, the distribution of the fluid will be greater at the two extremities. The phenomena of the *Leyden jar* are readily deduced, and all the facts connected with it may be anticipated even with numerical exactness, by the application of this theory. When a redundancy of electricity is thrown on one side of a pane of glass, the repulsion acting through the glass will drive off a portion of the natural electricity on the other side, the unsaturated matter of which will attract the free electricity thrown on the first side and thus neutralize its repulsive energy; and in this way an immense amount of electricity can be accumulated in a small space. When the two surfaces are joined by a conducting circuit a discharge takes place with great intensity, because the fluid on the charged side is impelled through the circuit by the repulsion of its own atoms, and because it is attracted to the other side by the unsaturated matter. If an insulated conductor in the form of a long cylinder with round ends be brought near a charged conductor, but not within striking distance, the natural electricity of the former will be repelled to the further end; the end nearer the charged body will be in a state of deficiency of electricity, or negatively electrified, while the further end will be in a state of redundancy, or positively electrified. Between the two ends there will be a point which will be neutral or

in its natural state. The intensity of this action diminishes rapidly with the distance, particularly in the case where the cylindrical conductor is short and the excited body is small; but in the case of atmospherical electricity, in which the charge is on the surface of a large cloud, the inductive action takes place through several miles of intervening space. An attempt was made by *Æpinus*, *Poisson*, and others, to apply the same hypothesis to the phenomena of magnetism. Between these and those of electricity a striking analogy was observed. For example, bodies which are dissimilarly electrified attract each other; those which are similarly electrified repel each other. In like manner, two similar poles of a magnet repel, and two dissimilar poles attract each other. Again, if the north pole of a magnet be brought near an unmagnetized bar of soft iron, the near end exhibits southern polarity and the further end northern polarity, apparently similar to the result of the action in the example we have just given of electrical induction. There is however this remarkable difference, that if we magnetize a piece of hardened steel in the same way by the induction of a powerful magnet, and afterward break the bar into two pieces, each half will exhibit a north and south pole of equal intensity; and if we continue to break each piece into two others, however far the division may be continued, the same result will be produced, namely, a pole at each end of each piece and a neutral point in the middle. From this experiment we infer that the polarity of magnetism results from the development of the magnetic power in each atom of the mass; while if the same experiment be made with an electrical conductor, that is, if it be separated into two parts while under the influence of the excited body, each half will exhibit a charge of only one kind of electricity. By considering therefore that electrical induction is produced by a bodily transfer of fluid from one end of the conductor to the other, and limiting the disturbance in magnetism to the particles of gross matter, a mathematical expression of most of the phenomena known previous to the discovery of *Oersted* was obtained. Still electricity and magnetism were so dissimilar in some particulars that they continued to be studied as distinct branches of science. The fact had long been noticed that discharges of lightning frequently gave polarity to bars of steel, and in some cases reversed the mariner's compass. A series of experiments to imitate these effects were made by *Franklin* and others by passing shocks through darning needles. The results were unsatisfactory, since the needle was sometimes magnetized in one direction and sometimes in the other, and frequently not at all, without any apparent change in the conditions. Indeed, ordinary electricity was not favorable to the study of the connection of electricity and magnetism, since the phenomena which belong to both are exhibited during the continuance of

an electrical current; and in the case of the discharge of a *Leyden jar* the transfer is so instantaneous that we are only able to study effects which have taken place, without being able to make any observations as to the manner in which they have been produced. This was the condition of the science up to the winter of 1819-20, when *Prof. Oersted* of *Copenhagen* put a new interrogation to nature by asking what would take place in regard to a magnetic needle when a wire transmitting a current of galvanism was brought near it. He found that when the wire was brought parallel to and near the needle, the latter tended to turn at right angles to the former. This was a new result, unlike any phenomenon before discovered. Previous to this, the connection between electricity and magnetism had been sought in the analogy of the polarity of the two ends of a magnetic bar and the two extremities of a galvanic battery, both of which exhibited polarity. An account of this remarkable discovery was published in all parts of the civilized world, and everywhere excited the interest of men of science. It was repeated in *England*, *France*, and *Germany*. The additional fact was discovered by *Arago* in *France* and *Davy* in *England*, that the wire joining the two poles of a galvanic battery while the latter was in action was capable of imparting magnetism to iron filings; but the person who seized on the phenomenon with the greatest avidity, and who in the course of a few months developed the whole subject to such an extent as to elevate it to the rank of a new science, was *Ampère*, of the *French academy*. He discovered an additional fact which gave a key to all that had previously been found by his contemporaries, namely, that two parallel wires transmitting currents of electricity in the same direction attract each other, while similar wires transmitting currents moving in opposite directions repel each other. On this fact, combined with the hypothesis that all magnetic action consists in the attraction or repulsion of electrical currents, he founded his celebrated theory of electro-magnetism, which gives in a single sentence a generalization from which all the known phenomena of electro-magnetism as well as ordinary magnetism can be deduced. This theory is based upon one fact and one hypothesis. The fact is this, that currents moving in the same direction attract, and moving in opposite directions repel, each other; the hypothesis is, that the magnetism of a bar of steel consists in currents of electricity revolving at right angles to the length of the bar around each particle of the metal, the resultant of which would be a current around the circumference of the bar. Let us suppose a number of shillings or cents piled one on the other, and cemented together so as to form a cylindrical column or rod 8 or 10 in. in height; and let us further suppose that on account of some molecular action a current of electricity is perpetually circulating in the circumference of each piece of coin, and that the direction of

the currents is the same in the whole series. If we further suppose that the column is standing on end, and that this motion is contrary to that of the sun and contrary to that of the hands of a watch when placed face upward, such arrangement will represent the hypothetical magnet of Ampère, in which the north end, or that which turns to the north, is uppermost, and consequently the south pole undermost. If these postulates be granted, instead of loading the memory with an almost infinite variety of disconnected facts, we shall have at once a generalization from which all the phenomena can be deduced at pleasure in a series of logical corollaries. If this theory be true, or if it be even an approximation to the truth, it will follow that if currents of electricity be transmitted through an arrangement of the kind we have described, the phenomena of ordinary magnetism will be exhibited; and this anticipation will be realized if we coil a piece of copper wire covered with silk into the form of a corkscrew spiral, forming a cylinder 8 or 10 in. long, and if the two projecting ends not included in the spiral be passed backward through the cylinder and made to project from the middle at right angles to the length of the cylinder on opposite sides. If this cylinder, the several spires of which will represent the pieces of money, be supported horizontally, so as to turn freely as a magnetic needle moves on its pivot, it will take a north and south position when a powerful current of galvanism is transmitted through the wire. Nay, more, another cylinder formed of like spires through which a current of galvanism is passing will act upon the first precisely as a magnet would act upon another magnet. Indeed, so long as the galvanic current is passing through this helix or spiral, it exhibits all the properties of an ordinary magnet; but they immediately disappear when the current is interrupted. To deduce from his theory the almost infinite number of facts which it involves, Ampère first considered the action of currents on currents. Starting with the hypothesis that the attraction and repulsion were inversely as the square of the distance between the elementary parts or smallest portion of the currents, he deduced mathematically the consequence that the force of a current of considerable length acting on a single element of a current would vary inversely as the simple distance; and this he was enabled to verify by experiment by suspending a bent wire through which a current was passing so as to be free to oscillate under the influence of a single element, which was ingeniously effected by doubling a piece of covered wire in the middle of its length, thus  $\gg$ . When a current was passed through this double wire, the portion of it which went to the point of bending and that which came from it neutralized each other, and the residuary effect therefore was that of a single point, which gave a result exactly in conformity to the deduction from the theory. After proving experimentally this fundamental principle, he was enabled by

mathematical reasoning, principally of a simple character, to deduce the resultant action of the most complex forms of conductors upon conductors. Among many others, the following important deductions immediately flow from the premises assumed. If a current of electricity be sent in the direction from A to

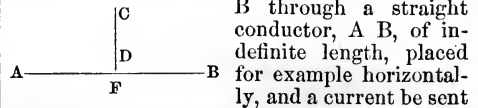

B through a straight conductor, A B, of indefinite length, placed for example horizontally, and a current be sent downward through a terminated conductor, C D, perpendicular to the former, the latter conductor will be impelled parallel to itself along the length of the horizontal conductor. This effect will be due to the fact that on the right side of the short conductor the elements of the two currents are moving in opposite directions; the current in the short wire is approaching the point F, while the current in the horizontal wire is moving from this same point, and hence on this side repulsion will take place; while on the left-hand side of the short wire the two currents are moving toward the same point, and therefore attraction will be exhibited; and under the influence of these two forces, the short conductor will move parallel to itself from right to left along the horizontal conductor. If the direction of the current in either of the two conductors be reversed, the motion of the short conductor will also be reversed. If, instead of the short conductor, one in the form of a ring be freely suspended over the long conductor, with the plane of the latter across the former, the current passed through this will ascend on one side of the ring and descend on the other. Therefore, the one side will tend to move to the right and the other to the left, and the resultant action will be to bring the plane of the ring parallel to the horizontal current; in which case the current in the lower part of the ring will be moving in the same direction as the current in the long wire. Now, since, according to the theory of Ampère, magnetism depends upon currents of electricity, it follows that the magnetism of the earth results from currents of electricity moving continually from east to west. Hence, if a conductor be bent into the form of a ring or hoop, and freely suspended, it will arrange itself east and west. To insure the success of this experiment, the hoop should be formed of a long wire covered with silk and coiled into the form of a ring so as to multiply the actions. Such a ring may be considered as one of the disks represented by the shillings in the hypothetical magnet; and since each disk making up the whole length of the rod would be similarly acted upon by the currents of the earth, the axis of the rod would assume a north and south direction if left free to move, thus affording an explanation of the fact, so long considered an ultimate one, of the directive property of the needle. Let us return again to the action of the long horizon-



tal conductor on the short perpendicular one. If the former be bent into a horizontal circle, then it is evident, from the reasons we have before given, that the short conductor, moving perpetually round it parallel to itself or retaining its perpendicular position, will describe a

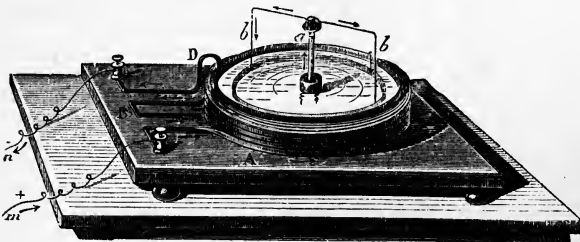

FIG. 1.—Rotation of a Vertical Current.

circle. This may be shown experimentally by bending a piece of wire into the form of a  $\cap$ , and supporting it vertically on the point of a perpendicular wire which fits lightly into a socket on the under side of the middle of the arch. (See fig. 1.) If the two ends of this bent wire dip into a circular basin of mercury through the middle of which, surrounded by a glass tube, the supporting pointed wire passes, and if a powerful current of galvanism be sent down through this wire, it will descend through the legs of the  $\cap$  into the mercury; and if at the same time a powerful current be passed through a ring or hoop conductor placed horizontally around it, a rapid rotation of the bent wire will take place. Now since magnetism, according to the theory which we have adopted, consists in currents of electricity revolving at right angles to the magnet, if a magnetized bar be introduced within the branches of the bent conductor, a similar rotary motion will be produced. This fact was first shown experimentally by Prof. Faraday. It is, however, a logical consequence of the theory of Ampère, and might have been deduced from it. A beautiful illustration of the phenomena of terrestrial magnetism was first exhibited by Prof. Barlow of Woolwich, England. He prepared a wooden globe, into the surface of which a long conductor was buried in a spiral groove extending with many turns from pole to pole. This globe was afterward covered with paper, on which were drawn the continents and oceans. When a small dipping needle was placed over this apparatus and a current of galvanism sent through the concealed conductor, the needle assumed a direction similar to that which would be due to an analogous position on the earth's surface; and since, in all cases, the needle tends to arrange itself at right angles with the direction of the current, by a proper adjustment of the conducting wire in the groove the variation of the needle at every point of the earth's surface could be accurately represented. The explanation of all the phenomena of ordinary

magnetism readily flows from the same principles. We have stated that if a magnet be broken in two, each half becomes a separate magnet, exhibiting north and south polarity. If the hypothetical magnet which we have illustrated by a pile of shillings be broken in the same way, each part will become a separate magnet, and the two ends of the two parts which were previously in contact will attract each other, because the currents will be revolving in the same direction; but if we turn the other end of one magnet to the same end of the other, repulsion will ensue, because the currents are revolving in different directions. By a little reflection it will not be difficult to explain or to anticipate the action of the two mag-

nets on each other under any assumed condition. In adopting this hypothesis, it is not necessary to contend for the actual existence of electrical currents in the magnet or even in the earth. It is sufficient to assert that all the peculiarities of the known phenomena of magnetism are precisely such as would result from an assemblage of currents such as Ampère has supposed to exist. It is probable that in the phenomena of magnetism a molecular distribution of the fluid takes place which is analogous to that in a wire transmitting a current. Indeed, we know that at the moment of magnetizing a bar of iron, a molecular change is produced in the metal of sufficient intensity to cause a sensible sound; a fact which was first noticed by Prof. Charles G. Page of Washington.—It is an interesting fact in the history of science, that discoveries in one branch serve to throw light on other branches, and in many cases to furnish instruments by which actions too delicate to be appreciated by ordinary means may be exhibited and measured. Soon after the discovery of Oersted, Prof. Schweigger of Germany covered a long wire with silk and coiled it into the form of a rectangle, within which he suspended by means of a fibre of silk a magnetic needle. When a very feeble current of electricity was sent through this conductor, each turn of the wire acted on the needle to turn it at right angles to its own direction; and in this way an instrument called the galvanometer was produced, by which the most feeble galvanic action in the form of a current is exhibited.—It has been before stated that Arago and Davy discovered that the conducting wire through which a galvanic current is flowing is capable of inducing magnetism in iron filings. They also showed that a discharge of ordinary electricity, when made above or below a sewing needle, gave it definite polarity; and in this way the reason of the failure of Franklin and others, who had attempted to magnetize steel wire by ordinary electricity, was explained. In these attempts the electricity was sent through the length of the

needle, instead of across or around it, as the theory of Ampère would indicate. Mr. Sturgeon, in England, was the first to construct an electro-magnet, which consisted of a piece of iron wire bent in the form of a horseshoe, insulated with a coating of sealing wax, over which was loosely coiled a few feet of copper wire. (See fig. 2.) When the current was sent

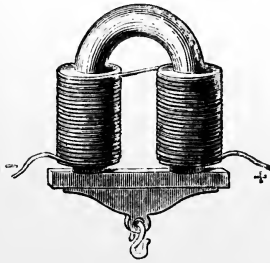

FIG. 2.—Horseshoe Electro-magnet.

through the latter, the iron became magnetic, and exhibited in proportion to its size a very intense action. The first person, however, who exhibited the great power of the galvanic current in producing magnetic effects was Prof. Henry of Washington. He found that by surrounding a large bar of iron bent into the form of a horseshoe with a number of coils of wire, so connected with the battery of a single element that the current in each wire would move in the same direction, a magnetic power of astonishing magnitude could be produced with a comparatively small galvanic apparatus. A magnet constructed on this principle, now in the cabinet of the college of New Jersey, at Princeton, will readily support 3,500 lbs. In order, however, to produce a maximum effect of this kind, it is necessary that great care be taken in the insulation of the wires, that there be no cutting across from one wire to another; and for this purpose the ends of two wires intended to be soldered to the positive pole of the battery should project together, while the two ends intended to be united to the negative pole of the battery should also be associated. If the magnetic power of the iron is to be developed by means of a compound battery, then a single long wire may be employed instead of a number of short ones. The power of the electro-magnet depends on the following conditions: on the energy of the current, the dimensions and form of the iron, the nature of the iron—the softer the better—the perfect insulation of the wire, and the proper adjustment of the length of the wire to the intensity of the battery. By means of an electro-magnet of the kind we have mentioned, the instantaneous development of an immense magnetic power is produced, by which discoveries have been made in regard to this mysterious agent, of the highest interest. Prof. Faraday showed by the application of this instrument that magnetic property is possessed by all bodies, either in the direction of the greatest length of the body, the form in which it is ordinarily developed, or at right angles to this length. He found, for example, that when different substances are made into bars and suspended by means

of a fibre of silk between the poles of a powerful electro-magnet, they arrange themselves with the longer axis in the direction of the pole or with the shorter axis in the same direction. Bodies of the former class are called magnetic; those of the latter class are called diamagnetic. This property is even possessed by gases. (See DIAMAGNETISM.) An electro-magnet even of immense power can be magnetized, unmagnetized, and remagnetized in an opposite direction, by instantaneous changes in the direction of the current of the galvanic battery. The large magnet we have mentioned as at Princeton can be loaded with several hundred pounds, and while in this condition may be so rapidly unmagnetized and remagnetized with the opposite polarity that the weight has not time to commence its fall before it is arrested by the attraction of the reverse magnetism. This sudden change of polarity affords a means of producing mechanical movements of considerable power through the agency of electro-magnetism, which have by some been considered as a rival to steam power. The first machine moved by this power was invented by Prof. Henry immediately after his experiments in developing electro-magnetism, and an account of it was published in the "American Journal of Science" in 1831. It consisted of an oscillating iron beam surrounded by a conductor of insulated copper wire. A current of electricity was sent through this in one direction, which caused one end to be repelled upward and the other attracted downward by two stationary magnets. The downward motion of the one end of the beam near its lowest point brought the conducting wires in contact with the opposite poles of the battery, which produced the reverse motion, and so on continually. In a subsequent arrangement, the velocity of motion was regulated by a fly-wheel, and electro-magnets substituted for the permanent magnets at first used. Prof. Ritchie of the London university afterward produced a rapid rotatory motion between the two legs of an inverted horseshoe magnet in a piece of iron around which a current of electricity was made to revolve, and the magnetism reversed at each semi-revolution. Modifications of these two forms of the apparatus have since been made in almost every part of the civilized world. A large electro-magnetic engine was constructed by Prof. Jacobi of St. Petersburg, by which a small boat was propelled at the rate of several miles an hour. But the largest and most efficient engine of this kind was constructed by Prof. Page of Washington, at the expense of the government. It exhibited sufficient power to propel with considerable velocity a railway car, and afforded the best means which has yet been presented of estimating the comparative cost of the application of electricity as a motive power. From all the experiments which have been made, it appears that though the electro-magnetic power can be applied with less loss in the way of effective work than heat by means of the steam engine,

yet the cost of the material by which it is generated is so great that it cannot be economically employed. According to the experiments of Despretz, one pound of coal in burning develops as much heat as six pounds of zinc; consequently, under the same conditions, six times as much power is developed from the burning of an equal weight of the former as from that of the latter. Now the power of the steam engine is produced by the burning of coal in air, while that of the electro-magnetic engine is developed from the oxidation or burning of zinc in acid; and since coal and air are the simple products of nature, while zinc and acid require artificial preparation at the expense of power, it must be evident that electro-magnetism cannot compete with steam, although it may be applied in some cases where the expense of materials is of secondary consideration. Electro-magnetism, for example, is applied with much success in calling into operation power at a distance, as in the case of the electro-magnetic telegraph, in giving simultaneous motion to the hands of clocks situated in different parts of a city, in measuring very minute portions of time, and in bringing into action the power necessary to ring alarm bells.—For an exposition of the scientific principles of electro-magnetism, see De Montferrand's work on the subject, translated from the French by Prof. Cumming of Cambridge, England; and for various ingenious modifications of apparatus, and interesting facts of the science, Dr. Page's papers in the "American Journal of Science and Art." (See GALVANISM, MAGNETISM, and MAGNETO-ELECTRICITY.)

**ELECTRO-METALLURGY, Electrotyping.** See GALVANISM.

**ELEMENT, Chemical.** In the present state of science this term admits of no very precise definition. In general the word element is applied to any substance which has as yet never been decomposed into constituents or transmuted into any other substance, and which differs in some essential property from every other known body. Several elements indeed occur under two or more allotropic conditions, in which states they exhibit different properties. These modifications are however mutually convertible into each other, and are regarded as mere varieties of one and the same substance. As now used, the term element does not possess in any degree the absolute signification at one time attached to it, none of the elements now admitted being regarded as proved to be primary principles of matter, although it is not impossible that some of them may be such. Provisionally, all substances which have hitherto resisted every method of analysis that has been applied to them—all, in short, which cannot be proved to be compound—are called elements. The number is increasing, some having been discovered by means of the spectrum analysis: cæsium and rubidium by Bunsen and Kirchhoff in 1860, thallium by Crookes in 1861, and indium by Reich and Richter in

1863. There are now 64 admitted in the list. Whether the number will continue to increase, or whether it may be diminished by the discovery that some of them are different conditions of the same substance, of course cannot be foretold. Some of these so-called elements are exceedingly rare, and have been seen but by few persons besides their discoverers. Two have been proposed which are not included in the list, dianium and norium, their existence being uncertain, and their properties not well known. The great mass of the matter of which the world is composed consists of about 30 elements, the remaining 34 being comparatively rare.—For a complete catalogue of the elements, see EQUIVALENT.

**ELEMI,** a resinous exudation from a number of trees in different parts of the world. Coming from so many sources, the substance known in common is by no means of uniform character, and the trees which afford the gum are very little understood. That from Holland is supposed to be from the Dutch East India possessions, and the product of the *canarium balsamiferum* of Ceylon. The Manila article is believed to be the product of the *canarium commune*; that of *C. album* or *arbolabrea* is used in the Philippine islands for pitching boats and vessels. The Brazilian elemi is from the *iceia icicariba*; the *iceia* is a genus separated from *amyris*, to which the elemi is commonly referred. The Mexican is said by Dr. Royle to be from a species of the *elaphrium*, which he names *elemiferum*. The resin is imported in various shapes, and in different colors and degrees of consistency. It was formerly much employed in plasters and ointments, but is more used in Europe than in this country. Hatters make use of it, and it is in some demand for varnishes by coach painters. It is one of the ingredients of pastilles, burned as incense. It has been resolved into two resins, one amorphous and one crystallizable; for the latter the name elemine has been proposed by its discoverer, M. Baup. In its medicinal properties it resembles the oil of turpentine.

**ELEONORA OF ESTE,** an Italian princess, born June 19, 1537, died Feb. 10, 1581. She resided in Ferrara at the brilliant court of her brother, Alfonso II., of which she and her sister Lucrezia were the most accomplished ornaments. Tasso seems to have conceived an ardent passion for Eleonora, and to have addressed to her some of his most fervent effusions, to the discovery of which the persecutions to which he was subjected by Alfonso were in part ascribed. But the evidence on the subject is conflicting. There were several other ladies of the name of Eleonora whom Tasso celebrated; as, for instance, Eleonora San Vitale, the beautiful countess of Scandiano, in whose praise he wrote charming verses. However, most biographers agree in pointing to the princess Eleonora as the lady of his special adoration. How far the princess reciprocated his affection is not clearly estab-

lished, and the presumption is that she gave him only friendship and poetical sympathy in return for his love. She was never married.

**ELEPHANT** (*elephas*, Linn.), the only existing representative of the proboscidian pachyderms, the mammoth or fossil elephant and the mastodon having lived in the preceding geological epoch. The elephant, the largest and heaviest of terrestrial animals, has from time immemorial been celebrated for his intelligence and sagacity, for the services he has rendered to man in eastern lands, for his imposing appearance, for his immense strength guided by gentleness and docility, and for the astonishing feats he is able to perform by means of his trunk. Since the time of Cuvier the anatomy of the elephant has been thoroughly studied. The skull is remarkable for its vertical elevation, giving to the head the well known aspect of sagacity; this, though far superior to that of the other pachyderms, has doubtless been overrated from the peculiar cranial formation in this animal. The great elevation of the frontal region does not arise from any increase of the cranial cavity or corresponding development of brain, but depends on the great separation of the tables of the skull, and the excessive enlargement of the frontal sinuses, affording ample space for the origin of the muscles of the trunk; the upper jaw has a similar structure for the accommodation of the enormous tusks; in both cases strength and solidity are obtained without too much weight. The nearly perpendicular facial line of the elephant, then, depends on the size of the frontal sinuses, the shortness of the bones of the nose, and the vertical position of the maxillary and intermaxillary bones; and the cranial cavity occupies but a small part of the head at its posterior central portion. The occipital bone forms the posterior wall of the skull, and advances also on to its upper surface; the parietals are early consolidated to it, to each other, and to the temporals, forming a solid box; the ethmoid is large, and the extent and surface of the cribriform plate indicate a delicate organ of smell; the sphenoid is very flat internally, but its cells are enormously developed, encroaching largely upon the base of the skull. The teeth consist of two long curved tusks, one in each intermaxillary bone, and of large and compound molars in each jaw. The permanent tusks, which are monstrous incisor teeth, are preceded by two small deciduous ones, which make their appearance between the fifth and seventh months, rarely exceed two inches in length and one third of an inch in diameter, and are shed before the second year, their roots being considerably absorbed; about two months after the milk teeth are shed, the permanent tusks, which are situated to the inner side of and behind the former, pierce the gum when about an inch long, and grow from the base during the whole life of the animal. The molar teeth are remarkable for their size and the complexity of their structure;

there is not more than one wholly, or two partially, in use on each side in each jaw at one time; they are constantly in progress of destruction and formation, succeeding each other horizontally, instead of vertically as in other mammals; according to Owen, the molars are successively brought forward until each jaw has had on each side 6, or 24 in all. Each tooth is composed of a number of transverse vertical plates of dentine or ivory, enveloped in enamel, and united together by the cement of *crusta petrosa*; only a small portion of the crown appears above the gum. This gradual progress of the teeth from behind forward explains how the elephant has always a grinding surface ready to bear the great pressure to which his teeth are always subjected; the constant wear of the grinding surface keeps it in order for mastication; the manner in which the enamel is arranged on this surface, after the ivory is worn down, enables the anatomist to refer a tooth either to the Asiatic or African elephant. From the oblique position of the molars in the jaws, the anterior portion pierces the gum first, and may be quite worn while the middle and posterior portions are slightly or not at all used, so that these teeth diminish in length at the same time that their depth is worn away; as the anterior grinding surface becomes useless, the root is removed by absorption, enabling the tooth to be pushed forward by that behind. The tusks are formed of ivory and enamel, the former making the central and by far the largest portion; the tusks exist in both sexes, but are smaller in the females than in the males; they sometimes measure 9 ft. in length, and weigh over 200 lbs. the pair; this great weight is kept in place only by the tight embrace of the socket and surrounding parts, explaining the abnormal direction of the tusks produced either by sudden and violent or by gentle and long continued pressure. The lower jaw is massive, and prolonged in front, where the extensible lower lip is elongated into a triangular deeply concave organ for receiving the extremity of the trunk. The spine consists of 7 cervical vertebrae, 20 dorsal, 3 lumbar, 5 sacral, and from 24 to 26 caudals; the number of ribs is 19, and in some specimens 20, of which 5 or 6 are true. The thoracic cavity is very large, the ribs being continued back nearly to the pelvis, of great size and width; the sternum is long, compressed laterally, and somewhat prolonged in front. The limbs being designed more for strength and solidity than speed, their bones are thick and large; the shoulder blade is wide, its posterior margin much the shortest; and the spine, beside the acromial process, has a broad, sickle-shaped prominence extending downward and backward; there is no clavicle, as the approximation of the limbs toward the centre of gravity is necessary to support the weight of the body. The humerus is short and massive, the upper extremity having a flat articular surface with large protuber-

ances for the insertion of the muscles of the shoulders, a strongly ridged shaft, and a pulley-like lower surface for the forearm, admitting only of flexion and extension; the external condyle is very extensive upward. The radius and ulna are permanently pronated, and both enter into the formation of the elbow and wrist joints; the eight bones of the wrist are arranged in two rows, and the five metacarpals are short and robust, five fingers being attached to them, but concealed by the thick and overhanging skin, with the exception of the ends. The pelvic bones are large, to accommodate the powerful muscles to which they give origin; the ilia are broad, rounded anteriorly and concave toward the abdomen; the femur is simple in shape, comparatively smooth, resembling considerably that of man; this resemblance is continued in the leg and tarsus; the os calcis is very large and prominent; the metatarsus consists of five bones, the external one being imperfectly developed; the toes are also five, each consisting of three bones, except the outer, which has one, all encased in the thick skin, the division being indicated only by the projecting extremities. The bones of the elephant may be easily distinguished from those of other quadrupeds; they resemble, except in size, the bones of man, particularly the cervical and dorsal vertebrae, the shoulder blade and pelvis, the femur, tarsus, and the bones of the metacarpus and metatarsus; so that it is not surprising that even anatomists, ignorant of the elephant's skeleton, should have mistaken their recent and fossil bones for the remains of gigantic human beings. The food of the elephant is entirely vegetable, and must be immense in quantity, and the digestive apparatus is accordingly largely developed. The stomach is simple, of a lengthened and narrow form, its cardiac extremity being prolonged into a pouch of considerable size, its internal membrane divided into thick folds and transverse wrinkles, and its muscular coat very thick; the small intestines are voluminous, and the large of enormous size; in a moderate-sized animal the intestinal canal was 60 ft. long, the small intestines being 38 ft., the cæcum  $1\frac{1}{2}$  ft., and the large  $20\frac{1}{2}$  ft.; the circumference of the first being 2 ft., of the second 5 ft., and of the last (colon) 6 ft. The gall bladder is situated between the coats of the duodenum, and is divided by transverse partitions into four compartments; the spleen is 4 ft. long. The heart resembles that of the rodents in having three venæ cavæ opening into the right auricle, two above and one below, and the Eustachian valve is furnished with a rudimentary superior division. The brain is small in proportion to the size of the animal; in one  $7\frac{1}{2}$  ft. high the whole organ weighed but 9 lbs., and in another 9 ft. high the internal capacity of the cranium was only 354 in., being less than three times the weight of the human brain, and less than four times the capacity of the Caucasian skull; the convolutions are well marked, and the cerebellum is proportionately very large;

the fifth pair of nerves, which supply the trunk, are enormously developed. The trunk of the elephant is an elongated nose, but is chiefly an organ of touch, though capable of being used for smelling; it forms a conical mass, 4 or 5 ft. long, gradually tapering to the end, which is provided with a thumb-like appendage, endowed with a most delicate sense of touch, and capable of picking up a needle; it contains a double tube, strengthened by membranes, extending up as far as the bony nostrils, just before which they form a sudden curve; the true nasal passages are provided with a valve by which the cavity of the trunk may be cut off from the nose, a provision rendered necessary when the animal takes fluid into the former. The great bulk of this organ is made up of transverse and longitudinal muscles so arranged that the trunk may be elongated, shortened, raised, and bent in any desired direction, with the precision of the human hand. Though the trunk is capable of performing the most delicate operations, it is also an organ of great strength and a weapon of the most formidable character; with it the animal tears the branches from trees in its search for food, performs the heaviest tasks for his human owner, and defends himself from his smaller enemies; with it he introduces food and drink into his mouth, which, from the shortness of his neck, he cannot bring to the ground; by inspiring through the trunk he fills it with water, which he discharges into his mouth or in refreshing showers over his back. So important is this organ that the animal's first act when in danger is to raise it above his head; when hunting the tiger or other wild animal, he carries it high in the air; any wound of it seems to render him helpless; in ordinary cases he rarely uses it to strike an object. When crossing deep rivers the body is deeply immersed, and respiration can be carried on with only the tip of the trunk above water. The sense of smell is acute, though not resident in the trunk proper, as is indicated by the extent of the frontal and maxillary sinuses communicating with the nose; the sphenoidal sinuses are also of unusual dimensions. The sense of hearing is also acute, as it should be for an animal living in thick woods and jungles, in which vision can hardly detect the approach of an enemy; the ear communicates with extensive bony cells, and the external auricle is large to collect the sounds and convey them to the tympanum. The eye is small, but is well protected by thick lids and a nictitating membrane. The muscular system is of immense strength; and the ligamentum nuchæ, which supports the heavy head, is of uncommon size and firmness.—Elephants inhabit the tropical forests of Asia and Africa, living in troops; though often destructive to trees, and especially to saccharine plants, they are quiet and inoffensive unless attacked; they prefer well watered regions, where a large herd may frequently be seen guided by some old male, keeping in the shade during midday and

feeding at morning and evening; easily alarmed, they retire to the woods at the approach of man, but if pursued will turn and attack him with the greatest fury. Only two species are described, the Asiatic and the African elephant. The Asiatic elephant (*elephas Indicus*, Cuv.), extensively distributed over S. India and the E. Asiatic islands, has an oblong head, concave forehead, and the crowns of the molars presenting transverse undulating ridges; the ears are small compared with those of the African species. The skin is hard and thick, wrinkled about the legs, neck, and breast; the general color is a brownish gray, mottled sometimes with lighter spots; pure white albinos are very rarely seen; the hairs are few and rigid, most abundant on the head; the feet have five toes, the nails of which are seen beyond the cutaneous envelope. The usual height is from 7 to 10 ft., that of the females a foot or two less; specimens are on record considerably larger than

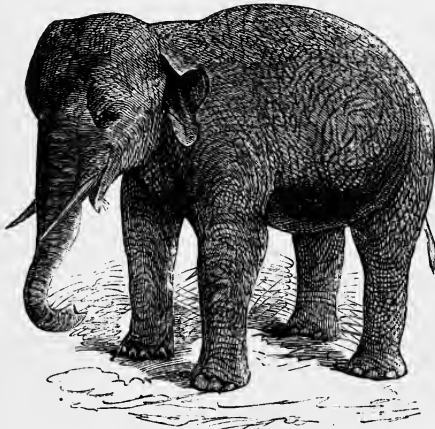

Asiatic Elephant.

this, some having a length of 15 ft. and a height of over 12 ft. The period of gestation is about 20½ months; the new-born animal is 3 ft. high, with all its senses perfect; sucking is performed by the mouth, the trunk being turned back, and is continued for a period of nearly two years. The young grow rapidly, being 4 ft. high in the second year, and are said to be suckled indiscriminately by any female in the herd; they attain maturity at about the age of 30 years, and live certainly for 150 years, and probably for 200. The weight of a full-grown elephant is from three to five tons. One kept in London for many years, between 10 and 11 ft. high, consumed daily three trusses of hay and about 200 lbs. of carrots and fresh vegetables, drinking from 60 to 80 gallons of water. Though the elephant will breed in captivity, the supply for domestic and warlike purposes must be kept up by hunting the wild animals and reducing them to servitude. The favorite way in India is to capture the wild by the aid of tame animals, especially females; these display

as much treachery, ingenuity, perseverance, and courage as ever did human seducer to compass the destruction of a victim. Following in the track of the male wild animals, the wily females move gradually toward them, grazing with the same complacency and indifference as if they were inhabitants of the forest; while the females are cajoling a male, the hunters cautiously approach and fasten his legs by ropes to trees, the former distracting the attention of the intended captive, and even assisting in binding the cords; the females then leave him, when he has discovered his condition, to vent his useless rage to his own exhaustion; further reduced by hunger and thirst, he will soon allow himself to be led by his treacherous companions to stations appointed for the training of elephants, where, after a few months' discipline, he becomes quite docile and contented. There are various other modes of taking elephants by female decoys, by stratagem, and by driving. Elephants, both Asiatic and African, frequently figure in the history of the wars of the Greeks and Romans. Darius III. had a small number of them in his war against Alexander; Porus of India brought a large number into the field against the same conqueror. Seleucus had hundreds of them in his army at the great battle of Ipsus. Pyrrhus of Epirus, Hannibal, and Antiochus the Great fought with elephants against the Romans, who themselves soon made use of them in their campaigns, and also exhibited them at their public shows, triumphs, and combats of wild animals in the theatres. In the ancient Indian empires elephants formed a necessary appendage to the royal retinue; they were used for show, for warlike purposes, and for carrying burdens. In the East at the present time elephants are employed for transporting baggage, dragging artillery over difficult places, and otherwise in connection with army movements, but without entering into the actual manoeuvres of battle; they exercise their strength and sagacity in lifting, dragging, and pushing with their leather-protected foreheads. When the elephant gets under full headway, his speed is considerable, and his momentum overcomes all ordinary obstacles; though able to carry an immense weight on a level surface, he is liable to totter and fall backward when forced up considerable elevations; a strong animal can travel 50 miles a day with a burden weighing a ton. The anecdotes illustrating the docility, affection, sagacity, irritability, capriciousness, and revengeful spirit of the elephant are innumerable. The natural enemies of the elephant, besides man, are the tiger and the rhinoceros, and the nasal horn of the latter often proves a more formidable weapon than the trunk and tusks of the elephant; the sight of even a dead tiger is enough to excite most elephants into a transport of fury.—The African elephant (*E. Africanus*, Cuv.; genus *Loxodonta*, F. Cuv.) has a more rounded head, a rather convex forehead, enormously

long ears, and cheek teeth with lozenge-shaped divisions of the crown; the generic name of F. Cuvier was founded on the last characteristic. It inhabits Africa from Caffraria to the Niger, living in similar localities and with the same manners as the other species. The males attain a height of over 12 ft., but decrease in size north of 20° S. latitude; the tusks, however, are larger as you approach the equator; the females are smaller than the males. The natives estimate the height of this species by doubling the circumference of the impression made by the fore foot; this is tolerably accurate for adult animals. In the most favorable localities the African elephant is considerably larger than the Asiatic; but toward the equator the female African is about as large as the Asiatic male. The ear of the African species is sufficient to distinguish it, being often more than 5 ft. long and 4 ft. wide, three times as large as that of the other species; it descends

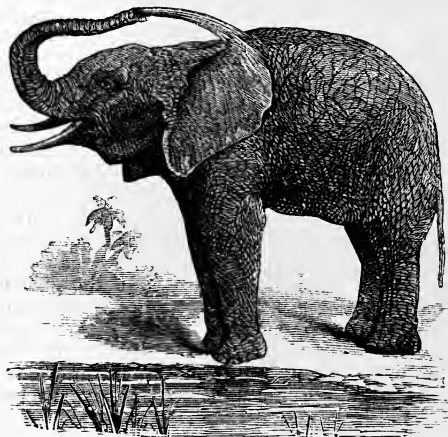

African Elephant.

upon the legs, and is frequently used as a sledge at the Cape of Good Hope. From the ancient coins it is evident that this species was known by the old naturalists, and it has been justly said that Aristotle knew it better than did Buffon. It seems to be a dainty feeder, selecting the sweetest fruits and vegetable matters containing sugar, mucilage, and gum; there is a dwarfish evergreen, the *speck boom*, which forms very dense jungles in Caffraria, utterly useless on account of its pithy branches even for fuel; this is a favorite food of elephants, which formerly frequented this region in large herds, whose paths are still discernible on the hillsides, and whose bones are still bleaching in all directions. From this selection of food they are not so injurious to the vegetation of a district as would be supposed, quality being more requisite than quantity. Most of the native tribes hunt them more for their flesh than their ivory, the latter, until the advent of Europeans, being of little value to them except for rings and ornaments; the

flesh is much relished as food, and the internal fat is highly prized for domestic and medicinal purposes. They hunted them with light javelins of their own making, overpowering them by numbers. This species is wilder and fiercer than the Asiatic elephant, defending its young with great courage, and furiously attacking the hunter; though not domesticated in modern times, it probably might be as easily as the other species, were the same pains taken to tame and train it; it can hardly be doubted that the elephants used by the Carthaginians in their wars with the Romans were of African origin. The male tusk is from 6 to 8 ft. long, and weighs from 60 to 100 lbs.; Cumming mentions a single one in his possession 10½ ft. long, and weighing 173 lbs.; the price which they bring in the English market is from £22 to £32 per 112 lbs., according to quality. Such is the terror which these animals have acquired from the persecutions of man, that a child will put a herd to flight; they are very difficult to hunt, from their hiding themselves in the most remote and inaccessible forests, going often 20 miles by night to water. When at ease they sleep on their sides, but when liable to be disturbed they sleep standing; their gait, when natural, is bold, free, light, and graceful. Cumming in his "Hunter's Life in South Africa" gives an interesting description of the manner in which the Bechuanas cook the feet and trunk of the elephant in hot earth and sand. In his experience from 5 to 30 rifle shots were necessary to kill an elephant, and the best place to direct them is just behind the shoulder; it is useless to aim at the front of the head, as the chances of a ball penetrating the brain from this direction are very small. Sir Samuel Baker in his "Rifle and Hound in Ceylon," however, says that he was accustomed to kill elephants by a single rifle shot directly in the forehead. —Many species of fossil elephants are described from the drift of Europe and Asia; the best known of these, the *E. primigenius* (Cuv.), will be treated in the article MAMMOTH, which is the common name; their remains have been abundantly found in Siberia, and fossil ivory from this source has been an important object of trade. The fossil elephants of Europe resemble most the Asiatic species, but they were more bulky, with larger tusks, narrower teeth, and with the skin covered with hair and wool to enable them to dwell in climates colder than any in which these animals are now found, though not in a climate so rigorous as that of Siberia at the present time, which would be unable to furnish the necessary vegetable food. Fossil species resembling the African, and others with mastodon-like teeth, have been found in the Himalaya mountains by Cautley and Falconer. The fossil elephant of North America is said by Prof. H. D. Rogers to occur above the drift, in the superficial deposits of a distinctly later age; it must therefore have been contemporary with the *mastodon gigan-*

*teus*; indeed their bones and teeth have been found side by side in the marshy alluvium of Big Bone Lick, and the two animals must have been exterminated together.

**ELEPHANTA**, or **Garapori**, a small island of British India, on the E. side of Bombay harbor, about 5 m. from the mainland; lat. 18° 57' N., lon. 73° E.; circumference about 5 m. It consists of two hills with a valley between them. It is much overgrown with wood, but diversified with some rice fields and pastures. The inhabitants, about 100 in number, are engaged in rearing sheep and poultry for the Bombay market. The usual landing place is on the S. coast, about 250 yards from which, rudely cut from an isolated black rock, was the figure of an elephant 13 ft. long, now fallen to decay, from which the European name of the island is derived. Further inland, about half way up the N. side of a hill, is a remarkable cave temple of unknown antiquity, which

capello. Several other figures of Siva, one of the four-faced Brahma, and one of the double deity, half male, half female, called Viraj, formed by the union of Siva with Parvati, are also to be seen. There are two smaller excavations on the E. and W. slopes of the hill, similar to the great temple, and filled with representations of Hindoo deities. But what is most remarkable is, that although most of the subjects of these sculptures are evidently Brahmanical, and the temples were probably dedicated to Siva, there is at least one figure which appears to be that of Buddha. No record of the origin of the shrines can be found. The general opinion of Europeans who have examined them is that they date after the birth of Christ, perhaps as late as the 9th or 10th century.

**ELEPHANTIASIS.** Under this common name two entirely different diseases are comprehended: *E. Arabum*,

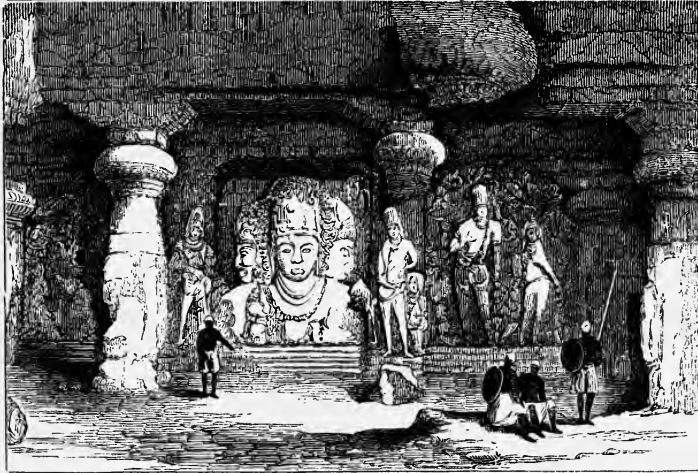

Triad Figure, interior of Temple at Elephanta.

has long been deserted by its priests, and is now frequented only by married women praying for fecundity. The spacious entrance, 60 ft. wide and 18 ft. high, is supported by two massive pillars and two pilasters, being thus divided into three passageways. The interior breadth of the cavern is 123 ft., and its length, presenting a seemingly endless vista of huge columns cut from the living rock, some of them broken by the Portuguese, who formerly possessed the island, is about 130 ft. The roof is generally flat, though not a perfect plane. The sides are excavated into compartments, all filled with mythological sculptures. Opposite to the main entrance there is a bust supposed to represent the Hindoo trinity, Brahma, Vishnu, and Siva. The heads are 6 ft. long and well cut. The head dresses are curiously ornamented, and among other symbols a human skull and a young infant are represented on that of Siva, who also holds in his hand a cobra de

Barbadoes leg; and *E. Gracorum*, elephant skin, or tubercular elephantiasis. I. *Elephantiasis Arabum* was described by Rhazes in the 9th century; it prevails extensively in Barbadoes, and is common in Demerara, Cayenne, and Brazil, in the S. W. part of the island of Ceylon, and on the Malabar coast in India; it is sometimes found in Castile and the Asturias in Spain, and occasional sporadic cases are met with throughout Europe and America. Notwithstanding its name, the disease is not con-

fined to the leg, but may attack almost any part of the body. The attack is ushered in by marked rigor, headache, pain in the back and limbs, followed by heat of the skin, alternating with profuse perspiration, and attended with burning thirst; at the same time some part of the body becomes red and swollen, hot and painful, particularly along the tract of the lymphatic vessels. In a few days the symptoms, both general and local, subside, with the exception that the affected part remains more or less swollen. At irregular intervals similar paroxysms recur, the affected part being each time left more swollen and indurated; as the enlargement increases, the skin often becomes rough, covered with scales, and fissured. The disease is usually confined to one part of the body, though occasionally both legs are affected. The affected parts often attain an enormous size. The causes of Barbadoes leg are not understood; its occurrence in particu-



lar districts shows that local causes have something to do with its production. In the West Indies the negroes, and in Ceylon the native race, are affected much more frequently than the whites; and of the whites, the creoles, those born in the country, are more liable than recent immigrants. In the treatment of the disease in the earlier stages, emollient applications, the warm bath, and bloodletting have been advised. Some physicians think benefit has been derived from the exhibition of mercury. When the disease has already made considerable progress, rest in a position which favors the return of the blood from the limb, and compression by means of proper bandaging, are the means most to be relied upon. II. *Elephantiasis Græcorum*, tubercular elephantiasis, appears to have been the disease which during the middle ages was known as leprosy; it is most frequently met with in the West India islands, and in other tropical regions, while it also prevails extensively in certain parts of Norway, where it is known as *spédalsked*. The disease ordinarily commences by the appearance of dusky shining spots upon the skin, slightly swollen, and more or less insensible. After a variable period, which may extend to months, and even years, these spots are succeeded by tubercles or small tumors, soft, reddish, or livid in color, and varying in size from a pea to an English walnut. These tubercles developed upon the face deform it excessively, giving it often a fancied resemblance to the head of the lion, whence one of the names by which the disease is known (*leontiasis*) is derived. As the disease advances, the tubercles become inflamed and ulcerated; the ulcers exude a sanious fluid, and this concretes into thick crusts; the bones become softened and altered in form. In the progress of the disease the gastro-intestinal mucous membrane becomes involved, and tubercles make their appearance in the pharynx; the sense of smell is lost, sight is weakened, and the touch blunted. In this wretched condition the patient may continue to exist a long time, unless cut off, as is commonly the case, by some intercurrent disease. In a second form of the disease, *E. anæsthetica*, patches of an irregular shape, sometimes slightly elevated above the surface, appear upon the extremities, of a tawny color; in whites they are lighter than the rest of the surface; in the negro they are dry, shining, rough, denuded of hair, and insensible. The hands and feet, and afterward the limbs, generally become swollen, stiff, and numb; ulcers form on the metacarpal and metatarsal articulations; these enlarge, penetrate the joint, and finally amputate the toes and fingers. As the disease advances, the pulse becomes slow and the bowels constipated; sometimes it is complicated with the tubercles of the other variety; in other cases the lobes of the ears, the wings of the nose, and the lips become thick, hard, swollen, and ulcerated. The patient is listless, and his in-

tellect enfeebled, and in this condition he may live many years. The causes of tubercular elephantiasis are unknown; it appears to be hereditary; but the once prevalent opinion of its contagiousness is not found to agree with recent observations. Of its proper treatment little is known.

**ELEPHANTINÉ**, or *Elephantina* (Arab. *Jeziret el-Sag*, "islet of flowers," or *Jeziret el-Aswan*), an island of the upper Nile, about 1 m. long and  $\frac{1}{2}$  m. broad, at the foot of the little cataracts, opposite Asswan, the ancient Syene. It is formed of granite covered with a fertile soil. It contains several ancient ruins; among others, the Nilometer mentioned by Strabo, whose upper part was destroyed in 1822, several dilapidated temples, and a gateway, as well as numerous fragments of pottery with Greek inscriptions. In antiquity Elephantiné or Elephantis was renowned for its fertility. Herodotus regards it as marking the boundary between Egypt and Ethiopia. Elephantiné was strongly garrisoned by the Persians as well as Romans. The present inhabitants are Nubians.

**ELEUSIS** (now *Levsina* or *Lepsina*), an ancient fortified town in Attica, on the bay of Salamis. It was said to have been founded by Eleusis, a son of Hermes. At an early period it was conquered by the Athenians and became one of the most populous cities of Attica. Its principal importance was derived from its being the seat of the celebrated Eleusinian mysteries. These mysteries formed a peculiar religious festival celebrated in honor of the goddess Demeter (Ceres), the patroness of agriculture, and the representative of the procreative power of nature. Originally these celebrations appear to have been something like modern thanksgiving festivals, but afterward a symbolic meaning was attached to them, and they became the vehicle of a secret science, conducive as was believed to eternal bliss. They consisted in dramatic representations of the myth of Ceres and the rape of Proserpine, her daughter, by Pluto, and would seem to have been intended to propagate the belief in the immortality of the soul, and to give an ideal meaning to the coarse fancies of the popular religion. The lesser Eleusinian mysteries were celebrated at Agræo on the Ilissus during the spring, and were a preparation for the greater. The great mysteries were celebrated at Athens and Eleusis in the latter half of September and the first of October; they lasted nine days. Except to murderers, barbarians, slaves, and afterward Epicureans and Christians, the admission to the public performances and religious exercises was free for all; but in the secret allegorical representations none but the initiated were allowed to participate, and they were bound by solemn oaths never to reveal what they had seen or heard. The unity of God and the immortality of the soul are supposed to have been the secret doctrine of the mysteries; and the symbolism of the ceremonies was probably, as Bishop Thirlwall

suggests, the remains of a worship which preceded the rise of the Hellenic mythology. In 1858 a Greek schoolmaster named Vlastos discovered at the village of Hagi-Constantios an inscription upon an old marble slab, containing rules and regulations for the celebration of the Eleusinian mysteries, but nothing was learned from them about their allegorical meaning.—See Uvaroff, *Essai sur les mystères d'Éleusis* (3d ed., Paris, 1816), and Preller, *Demeter und Persephone* (Hamburg, 1837).

**ELEUTHERIA** (Gr. *ἐλευθέρια*, freedom), among the ancient Greeks, a festival commemorative of deliverance from the armies of Xerxes. It was instituted after the battle of Plataea (479 B. C.), and celebrated annually at that place in the month Maimacterion, nearly corresponding to our September. At the dawn of day a procession marched through the town, at the head of which trumpeters blew the signal for battle. At midday a chariot was driven toward the altar crowned with myrtle and various garlands, and leading behind it a black bull. In front of the altar the archon of Plataea immolated the bull to Jupiter and Mercury, eulogized the heroes who had fallen at Plataea, and sprinkled the ground with wine. Every fifth year these solemnities were attended by contests, chaplets being the reward of the victors.

**ELGIN**, a S. W. county of Ontario, Canada, on the N. shore of Lake Erie, traversed by Otter creek, and bordered by the Thames river; area, about 730 sq. m.; pop. in 1871, 33,666. Capital, St. Thomas.

**ELGIN**, a city of Kane co., Illinois, on both banks of Fox river, which is spanned by an iron bridge, and on the Chicago and Northwestern railroad, 35 m. W. N. W. of Chicago; pop. in 1870, 5,441. It is laid out with broad streets, contains many brick blocks, and is well provided with shade trees. There is good water power and an active trade with the surrounding country. It is chiefly noted as the seat of the national watch factory, established in 1866, which has a capital of \$1,500,000, employs 550 hands, half of them females, and manufactures 50,000 watches a year, valued at \$850,000. There are also a woollen mill, a flouring mill, a butt and screw factory, a milk-condensing establishment, and two national banks. The city contains 16 public schools, including a high and two grammar schools, with an average attendance of 928 in 1872; two newspapers, a monthly periodical, and several churches.

**ELGIN**, a royal, parliamentary, and municipal burgh and market town, capital of Elginshire, Scotland, on the S. bank of the Lossie, 115 m. N. of Edinburgh; pop. of parliamentary burgh in 1871, 7,339. It is surpassed by few cities of Scotland in the number and interest of its ancient monuments. In former times it was a bishop's see; its cathedral was founded in 1224, and was burned in June, 1390, by Alexander Stuart, commonly called the wolf of Badenoch. Bishop Barr soon after erected in

its stead a cruciform church with three towers. About 1568 the privy council ordered the lead to be stripped from the roof and sold to maintain the soldiers of the regent Murray. The noble structure has ever since been falling piecemeal to destruction. The great central

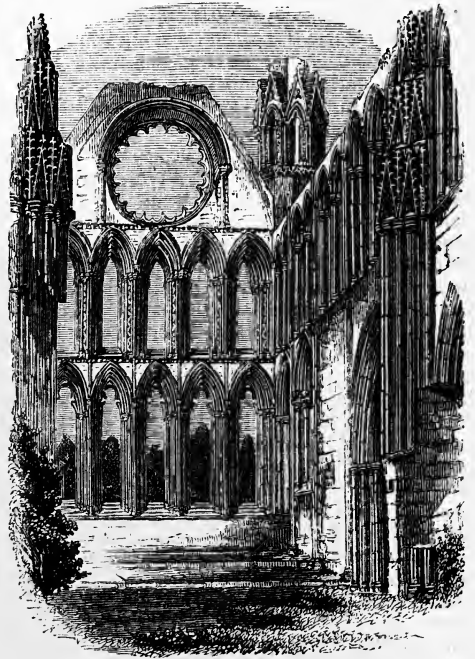

Elgin Cathedral.

tower and spire, 198 ft. high, fell in 1711. The chapter house, a beautiful octagon building, with a groined roof, supported by a handsome column in the centre, and elaborately ornamented, is still entire. As late as the beginning of this century Elgin bore an antiquated look, but new houses and streets have taken the place of the old; assembly rooms have been fitted up; a neat modern church has been built; and the streets are well swept, drained, and lighted with gas. Gray's hospital or infirmary, an institution endowed with £26,000, occupies an elevated site in the western part of the city. An orphan asylum here was endowed with £70,000. Elgin has a considerable trade in corn and wool, and markets are held on each Tuesday and Friday. It has also a woollen manufactory, tannery, millstone quarry, and lime works. Three weekly newspapers are published.

**ELGIN**. **I. Thomas Bruce**, 7th earl of Elgin and 11th of Kincardine, a British diplomatist, born July 20, 1766, died in Paris, Nov. 14, 1841. He passed some time at Harrow and at the university of St. Andrews, studied law in Paris, and having pursued military studies in Germany, entered the army and rose to the rank of general. His time, however, was mostly

passed in diplomatic employments. After filling missions to Brussels and Berlin, he was sent in 1799 as envoy extraordinary to Constantinople, when the idea occurred to him of rescuing from time and the Turks and removing to England the celebrated sculptures which are now in the British museum, and bear his name. He procured the permission of the Porte to take away from the ruins of ancient Athens "any stones that might appear interesting to him." With the aid of a corps of artists from Italy, and at his own expense (the British government having declined to further the undertaking), he succeeded in the course of ten years in detaching from the Parthenon, or in excavating from the rubbish at its base, abundant specimens of the various descriptions of sculptures with which it was ornamented. The first instalment of these treasures of antiquity arrived in England in 1808, and excited a feeling of admiration and delight, not unmingled, however, with indignation at what was considered the vandalism of Lord Elgin in removing them from their original resting place, or with doubts as to their artistic value. It was said that he had spent much time and money in procuring indifferent Roman marbles of the time of Hadrian, and the project of purchasing them for the nation was strongly opposed. Lord Byron is said to have carried his feelings on the subject of the alleged depredations of Lord Elgin to such an extent, that on a visit to the Parthenon he inscribed in a conspicuous place, *Quod non fecerunt Gothi, hoc fecerunt Scoti*; and he further gave vent to his indignation in the "Curse of Minerva," written in 1811. Among those who urged upon government the purchase of the marbles was the painter Haydon, whose style received its direction from the contemplation of them, and to whose earnest pleas with men in power was partly attributed the offer of £30,000 for the entire collection, made by Mr. Perceval, the premier, in 1811, which however was refused. In 1812, 80 additional cases arrived in England, a number of valuable marbles having previously suffered shipwreck, and in 1815 Lord Elgin offered to make over the collection to the nation for a reasonable sum. In the succeeding year the purchase was effected for £35,000, the actual outlay having exceeded £50,000. The services of Lord Elgin in bringing within the reach of artists, as well as in preserving from the ravages of time, these masterpieces of antiquity, are now fully appreciated; subsequent events having shown that, had he not removed them, the greater part would have been long since destroyed. In the war of Greek independence, and especially in the last siege of Athens in 1826-'7, the Parthenon suffered very serious damage. Lord Elgin was a Scotch representative peer for 50 years. In 1810 he published in defence of his conduct a 4to volume, entitled "Memorandum on the subject of the Earl of Elgin's Pursuits in Greece." **II. James Bruce**, 8th earl of Elgin

and 12th of Kincardine, a British statesman, son of the preceding, born July 20, 1811, died at Dhurmsala, India, Nov. 20, 1863. His studies were begun at Eton, and completed at Christchurch, Oxford, where he graduated in 1833. He was afterward elected fellow of Merton college. He commenced public life as one of the members of parliament for Southampton in 1841, but before the year was out succeeded to the title and estates of his father. In 1842 he was appointed governor of Jamaica, and in 1846 governor general of Canada. He negotiated in 1854 a treaty of commercial reciprocity with the United States, after which he resigned his office, returned to England, and received the appointment of lord lieutenant of Fifeshire. In the spring of 1857 he was appointed minister plenipotentiary to Peking, immediately proceeded to the East, was present at the taking of Canton, and, in conjunction with the French, succeeded by vigorous measures in reducing the Chinese to terms. After signing a treaty with the Chinese commissioners at Tientsin, June 26, 1858, the conditions of which were highly favorable to the British, he sailed for Japan, entered the harbor of Yedo, which the Americans had opened to foreigners, obtained important commercial privileges for his countrymen, concluded a treaty with the Japanese, Aug. 26, and in May, 1859, returned to England. He was again sent to China in the following year, and on the conquest of Peking by the allied French and British entered that city in triumph. He returned in 1861, and in 1862 was appointed viceroy and governor general of India, but was soon compelled by ill health to resign, and died shortly after. His "Letters and Journals," edited by Theodore Walrond, was published in London in 1872.

**ELGIN MARBLES**, a collection of ancient sculptures chiefly taken from the Parthenon at Athens, now deposited in the British museum. They derive their name from the earl of Elgin. (See **ELGIN**, **EARL OF**.) The sculptures on the Parthenon consisted of three kinds: the colossal statues on the tympana of the pediments, the metopes, and the frieze around the cella. Of the first, the Elgin collection contains statues or fragments of statues from both pediments, those from the eastern, on which was represented the birth of Minerva, being the best preserved, while those representing the contest of Neptune and Minerva for the possession of Attica are chiefly torsos and fragments, procured by excavation. Of the 92 metopes, it contains 15 from the S. side of the building, representing in high relief the combats of the Centaurs and Lapithæ, and a cast from another now in the Louvre. The slabs from the frieze of the cella, representing in low relief the great Panathenaic procession, are the most numerous and the best preserved of all the specimens in the collection. In addition to these, Lord Elgin procured from the ruins about the Athenian Acropolis the colossal

statue of Bacchus from the choragic monument of Thrasylus, one of the caryatides from the temple of Pandrosus, a portion of the frieze from the Erechtheum, and fragments of the columns of the Parthenon and Erechtheum; numerous inscriptions, including that commemorating the Athenians who fell at Potidæa; and urns, &c., taken from various parts of Athens and its neighborhood. The sculptures executed by Phidias, as has been generally supposed, or under his direction, exhibit the highest development of Greek art. As types of beauty they have never been surpassed, and even in their present fragmentary condition they afford models of form which modern art has not been able to equal. Under their influence a national school of sculpture has been established in England. A paper in "Blackwood's Magazine" for December, 1873, by W. W. Story, controverts the opinion that Phidias was the sculptor of the Parthenon marbles.

**ELGINSHIRE** (formerly **MORAYSHIRE**), a N. E. county of Scotland, bounded N. by Moray frith; area, 528 sq. m.; pop. in 1871, 43,598. It is divided into two parts by a detached portion of Inverness-shire, the smaller on the south. It has a coast line of about 30 m., on which are a few small harbors. With the exception of some broken masses of rock, the surface in this quarter is nearly level, but inland it rises into hills, interspersed with fertile valleys, and diversified by lakes. The Spey, Lossie, and Findhorn, the first and last of which contain salmon, are the chief rivers. Slate and freestone are the only valuable minerals. The climate is mild and dry; the soil of the lowlands is generally fertile, and the hills furnish pasturage for black-faced sheep, cattle, and horses. The staple production is wheat, but oats, potatoes, and turnips are also grown extensively. Less than a quarter of the land is cultivated, and there are large unenclosed tracts. Corn, whiskey, fish, and timber are the most important exports. The county is traversed by a number of good roads, but has no canals or railways. Chief towns, Elgin, Forres, Fochabers, and Burghead.

**ELI**, judge of the Hebrews immediately before Samuel. He was of the race of Aaron, and officiated as high priest and judge during 40 years; yet he lacked the power to discipline his own family, and a train of woes befell him and his house during the latter years of his life. His piety was exemplary, but his inefficiency was a source of many calamities. After a disastrous battle with the Philistines (about 1110 B. C.), in which his two sons were slain and the ark of the Lord was captured, Eli, on hearing the last news, fell back from his chair and broke his neck, at the age of 98.

**ELIAS**. See **ELIAH**.

**ELIAS LEVITA** (Heb. *Hallevi*, the Levite), a Hebrew scholar, born according to some in Franconia, according to others in Italy, about 1470, died in Venice in 1549. At the beginning of the 16th century he lectured in Padua

on Hebrew grammar, and wrote a commentary on one of Moses Kimhi's grammatical works (Pesaro, 1508; frequently reprinted). When Padua was plundered in 1509 he lost all his property, and afterward visited Venice and Rome. Here he became the teacher in Hebrew of Cardinal Egidio. He was again reduced to poverty by the sack of Rome in 1527, and returned to Venice. In 1540, with Paul Fagius, he established a Hebrew printing office at Isny, Swabia; and in 1547 he again established himself in Venice. He rejected many of the Hebrew traditions, and spoke so favorably of the Christians that he was suspected of infidelity to Judaism. But his high personal character and his profound scholarship were never questioned. Besides numerous lexicographical and grammatical treatises, of which his *Tishbi* (Isny, 1541; Basel, 1557) and *Ba'hur* (Rome, 1518; Basel, 1825) are the most celebrated respectively, he wrote poems, translated the Psalms into German, and was said to be the author of the Jewish-German novel *Baba*. But his great work was *Masoreth hammasoreth* (Venice, 1538), a critical commentary on the Biblical text and its authors. The best translation is the English, published, with a critical edition of the original, by Dr. Ginsburg (London, 1867).

**ÉLIE DE BEAUMONT**, Jean Baptiste Armand Louis Léonce, a French geologist, born at Canon, Calvados, Sept. 25, 1798. In 1821 he undertook, by order of the government, a series of metallurgical explorations, and was made on his return in 1824 a mining engineer. In 1829 he became professor at the school of mines, in 1832 at the collège de France, and in 1833 engineer-in-chief. After the death of François Arago he was made perpetual secretary of the academy of sciences. Napoleon III. appointed him senator. He was appointed in 1823, together with Dufrénoy, to aid M. Brochant de Villiers in preparing the materials for the geological map of France; and in this commission they were charged to visit England, where a similar work was in progress, and at the same time to examine the metallurgical operations there practised. The results of their investigations were published by Dufrénoy and Élie de Beaumont in a work entitled *Voyage métallurgique en Angleterre* (1827), illustrated with numerous plates, and afterward enlarged with the aid of Léon Coste and Perdonnet. Élie de Beaumont afterward devoted himself almost exclusively to geological researches, while engaged upon the preparation of the map of France, and published frequent papers in the *Annales des mines* and other scientific journals. In his *Notice sur les systèmes des montagnes* (1852), he endeavored to prove that mountain chains are to be classed according to the direction of their range, all those lying parallel with the same great circle of the earth, wherever they may be found, having been uplifted suddenly during the same geological epoch. He described in the last edition of his work the

features of no less than 95 systems of mountains; and the facts he collected added largely to the geological knowledge of the day. A decree of 1868 appointed him to direct a geological survey of France.

**ELIJAH** (in the New Testament called **ELIAS**), a Hebrew prophet, whose history is given in the later chapters of the first book of Kings, and in the opening chapters of the second. He suddenly appeared before King Ahab, declaring that as a punishment for the king's iniquities neither dew nor rain should fall for years, until he himself announced the change. He took refuge from the wrath of the monarch in the desert, by the brook Cherith, where he was miraculously fed by ravens; and after the drying up of the brook he proceeded to Zarephath, where he was supported by a poor widow, for whom his presence was a source of blessings during the distresses of the time. After drought and famine had desolated the country during three years, he reappeared before the king, offering to demonstrate the vanity of the worship of Baal. He requested Ahab to assemble on Mt. Carmel the idolatrous priests, 850 in number, who had followed in the train of Queen Jezebel, and there defied them to make fire fall from heaven to consume their sacrifice. The long prayers of the Baalites were without success, but in answer to Elijah's short prayer the fire came down and consumed not only the bullock but the altar. The people instantly massacred the priests, and then Elijah promised an end to the famine, and there was an abundant rain. But Jezebel swearing revenge for the destruction of the priests, Elijah again fled to the wilderness of Mt. Horeb and hid himself in a cavern. Then he was commanded to return and anoint Hazael king over Syria and Jehu over Israel, and appoint Elisha as his own successor. On his way he found Elisha and made him his disciple, and as he appeared again before Ahab, who was guilty of the blood of Naboth, the king humbled himself and repented. Ahaziah, the son of Ahab, who succeeded to the throne, fell ill, and Elijah announced to him through his agents that his sickness would end in death. Ahaziah sent a captain and 50 armed men to seize Elijah; but fire from heaven consumed the band. A second company met with the same fate. At length Elijah appeared personally before the king and repeated his announcement. His mission was now accomplished. He made a visit to the school of the prophets at Bethel, and having in company with Elisha crossed the Jordan, the waters of which he divided by smiting them with his mantle, he was taken up into heaven by a whirlwind, in a chariot of fire drawn by horses of fire. The date of the termination of his career is fixed in the beginning of the 9th century B. C.—In the New Testament Elias is mentioned as appearing with Moses to Christ at his transfiguration on the mount. He has been canonized in both the Greek and Latin churches. Among the Chris-

tians in the East Mar Elias is the patron of elevated places, and many conspicuous summits are called after his name. Two convents in Palestine are dedicated to him, one near Jerusalem, and the other on Mt. Carmel. His day is July 20, under which date the traditional account of him will be found in the *Acta Sanctorum*. The Mohammedan traditions respecting him are given in the introduction to Lane's "Arabian Nights."

**ELIOT, Charles William**, an American educator, born in Boston, Mass., March 20, 1834. His father was Samuel Atkins Eliot, the author of a "History of Harvard College," a member of congress in 1850-'55, and for 11 years treasurer of Harvard college. At the age of 15 the son entered Harvard college, and graduated in 1853. Immediately afterward he was appointed a tutor in mathematics, and held that position till 1858, when he became assistant professor of chemistry. In 1863 he resigned his professorship and went abroad, in order to perfect himself in chemical research and to study the various methods of scientific and literary education in England and on the continent. Returning home in 1865, he was appointed professor of chemistry and metallurgy in the Massachusetts institute of technology. In the spring of 1869 he was chosen president of Harvard university, as the successor of Dr. Thomas Hill, and was inaugurated on Oct. 19. President Eliot has been a frequent contributor to the "Atlantic Monthly," "Journal of Science," and other periodicals; and he is the joint author of a "Handbook of Chemistry" (Boston, 1868). In 1869 he received the degree of LL. D. from Williams and Princeton colleges, and in 1870 from Yale college.

**ELIOT, George.** See LEWES, MARIAN EVANS.

**ELIOT. I. John**, commonly called the "Apostle of the Indians," born at Nasing, England, in 1604, died at Roxbury, Mass., May 20, 1690. He was educated at Cambridge, and in 1631 came to Boston, Mass., where he preached to the church of Mr. Wilson, who was then in England. In 1632 he was settled as teacher of the church in Roxbury. Being impressed with the benighted condition of the Indians, whom he fancied to be the descendants of the lost tribes of Israel, he commenced preaching to them in their own language at Nonantum, now a part of Newton. He had acquired their language through the assistance of an Indian servant in his family who had learned English. The first service was held Oct. 28, 1646. After prayer he stated the leading doctrines of Christianity, and applied them to their condition, inviting his hearers at the close to ask any questions. One asked whether God could understand prayers in the Indian language; another, how could there be an image of God since it was forbidden in the second commandment; another, how the Indians could differ so much from the English in their views of religious truth if they all at first had but one father; another, how came the world so full

of people if they were all once drowned in the flood. The conference lasted three hours, and was followed by others in which similar queries were propounded by the Indians, one of whom, very aged, inquired whether it was too late for such an old man as he to repent and be saved. Eliot was strongly opposed by some of the sachems and conjurers, who threatened him with violence if he did not desist from his labors; but his answer was: "I am about the work of the great God, and he is with me, so that I neither fear you, nor all the sachems in the country. I will go on; do you touch me if you dare." A settlement of "praying Indians" was soon formed at Nonantum, which in 1651 was removed to Natick, where in 1660 an Indian church was organized, and the community flourished for many years. Eliot travelled extensively, planted a number of churches, visited all the Indians in the Massachusetts and Plymouth colonies, and once preached the gospel to the famous King Philip, who rejected it in disdain. He induced large bodies of Indians to give up their savage customs and form themselves into civilized communities, led many persons to engage in the missionary work among them, and lived to see 24 of them become preachers of the gospel to their own tribes. His influence over the Indians was almost unbounded. He protected them in 1675, during Philip's war, when some of the people of Massachusetts had resolved to extirpate them; and though he suffered much abuse for the part he took, nothing could shake his friendship for them. At the age of 80 he offered to give up his salary from the church in Roxbury, and desired to be released from his labors as their teacher; and when, from increasing infirmities, he could no longer visit the Indians, he persuaded a number of families to send their negro servants to him every week, that he might instruct them in the word of God. He gave to the Indians most of his annual salary of £50, which he received from the society for propagating the gospel; and it is related that on one occasion, when the parish treasurer was paying him, he tied the ends of the handkerchief into which he put the money in as many hard knots as possible, to prevent Mr. Eliot from giving it away before he should reach home. Calling at once, however, on a family suffering from sickness and want, he told them God had sent them relief, and began to untie the knots; but becoming impatient, he gave handkerchief and all to the mother, saying: "Here, my dear, take it; I believe the Lord designs it all for you." Richard Baxter said of Mr. Eliot, "There was no man on earth that I honored above him." All New England bewailed his death, and Cotton Mather tells us, "We had a tradition that the country could never perish as long as Eliot was alive."—A list of the published works of Eliot may be found in his life, in Sparks's "American Biography." Among them are accounts of the progress of the gospel among

the Indians; the "Christian Commonwealth," published in England about 1660, which when received in Massachusetts was regarded as so seditious, that the governor and council required Eliot to retract its teachings, because opposed to the monarchy of their native country; an Indian grammar (1664); the psalms translated into Indian metre (1664); and a harmony of the gospels, in English (1678). His great work, however, was the translation of the Bible into the Indian tongue; the New Testament was first published at Cambridge in 1661, and the Old in 1663; and both were issued in subsequent editions. This was the only Bible printed in America until a much later period. Copies of it are very rare, and have been sold at £170 and £210. In a late London catalogue a copy is quoted at £225. A copy was sold in New York in 1868 for \$1,130. The language in which it is written has utterly perished, and only one or two persons in modern times have been able to read it.

**II. Jared**, grandson of the preceding, minister of Killingworth, Conn., born Nov. 7, 1685, died April 22, 1763. He was a preacher, a botanist, and a scientific agriculturist, introduced the white mulberry tree into Connecticut, and discovered a process of extracting iron from ferruginous sands. He was also the first physician of his day in the colony, was sometimes sent for to Newport and Boston, and was more extensively consulted than any other physician in New England. He published "Agricultural Essays" (1735, several times reprinted), "Religion supported by Reason and Revelation" (1738), and sermons.

**ELIOT, John**, an American clergyman, born in Boston, May 31, 1754, died there, Feb. 14, 1813. With Dr. Belknap he cooperated in establishing the Massachusetts historical society, and in 1809 published the "New England Biographical Dictionary." He also published sermons and biographies.

**ELIOT, Samuel**, an American author, born in Boston, Dec. 22, 1821. He graduated at Harvard college in 1839, and passed two years in a counting room and four years in foreign travel and study. While in Rome in 1845 he conceived the plan of writing a history of liberty, the first portion of which he published in Boston in 1847, under the title "Passages from the History of Liberty." In this work he reviewed the career of Arnold of Brescia, Giovanni di Vicenza, Savonarola, and other early Italian reformers. In 1849 appeared "The Liberty of Rome" (2 vols. 8vo, New York). A revised edition was published in 1853, under the general title, "The History of Liberty," with two additional volumes: part I., "The Ancient Romans;" part II., "The Early Christians." These constitute a portion of an extensive history, the remaining three parts of which the author intends to devote to the papal ages, the monarchical ages, and the American nation. In 1856 he was appointed professor of history and political science in Trinity college, Hart-

ford, and the same year published a "Manual of United States History, 1492-1850" (12mo, Boston). He was president of Trinity college from 1860 to 1866, and is now (1874) professor of political science and constitutional law in that institution.

**ELIOTT, George Augustus**, Baron Heathfield, a British general, born at Stobbs, Roxburghshire, Scotland, in 1718, died in Aix-la-Chapelle in July, 1790. He was educated at the university of Leyden, and subsequently studied the art of war in the school of artillery at La Fère. He entered the British army in 1735, distinguished himself at Dettingen and in other actions in Germany and the Netherlands, obtained the rank of lieutenant general, and in 1775 was appointed governor of Gibraltar, which he successfully defended for more than three years against the combined French and Spanish forces. On his return to England he received the thanks of both houses of parliament, and was made a knight of the bath by George III.; and in 1787 he was raised to the peerage as Baron Heathfield of Gibraltar.

**ELIS**, or **Elea**, in ancient Greece, a division of the Peloponnesus, extending along the Ionian sea from the promontory of Araxus to the river Neda; greatest breadth about 35 m., from the promontory of Chelonatas to the foot of Mt. Erymanthus, where the boundaries of Elis, Arcadia, and Achaia come together; area, about 1,000 sq. m. It contained the western slopes of the Achaian and Arcadian mountains, Erymanthus, Pholoë, and Lycæus; and though its surface was for the most part uneven, it had many valleys and hillsides of great fertility. Its principal rivers were the Alpheus (now Ruphia) and the Peneus (Gastuni). The whole territory included three districts: Elis, in its narrower sense, or Hollow Elis; Pisatis, separated from the first by a branch of the Pholoë mountains; and Triphylia, lying S. of the Alpheus. Of these, Hollow Elis, so called from its being a vale set in a circle of mountains, was the most northern and the most fertile. Here, and nowhere else in Greece, grew the fine flax called *byssus*. At the time of the Doric invasion, Oxylus led the Heraclidæ south by the more difficult way of Arcadia, lest they should see and be attracted by the richness of this plain. Hollow Elis contained three cities, Elis, its port Cylene, and Pylos. These were unwall'd, and protected only by the sanctity of the country; for by the common law of Greece Elis was a sacred state and inviolable, on account of its possession of the temple of the Olympian Zeus on the banks of the Alpheus. This sacred character of Elis was, however, disregarded during the Peloponnesian war by the Athenians. Afterward King Agis of Sparta pressed across the Larissus to attack Elis, but on the first attempt fled, alarmed by an earthquake; and he failed in a subsequent attack. Pisatis, which was the lower valley of the Alpheus, had eight cities, two of which, Pisa and Salmone, are

celebrated in the legends of Enomaus, Pelops, and Salmoneus. In this district was Olympia, the seat of the most famous of the Greek games, and the quadrennial scene of the most splendid of Greek assemblages. From the time of the Doric invasion there was hostility between the proper Eleans and the Pisatians, caused by the claim of the former to direct the Olympic games. This jealousy gave rise to several wars. The Eleans, finally victorious in the 52d Olympiad, destroyed the city of Pisa. Triphylia, the smallest and the southern division of Elis, was separated from Messenia by the Neda, and was fertile only in the interior. Here was Mt. Minthe, the highest in Elis, one of the seats of the worship of Hades. The Eleans took part in the Trojan, Peloponnesian, and the other general Grecian wars, and were constantly in strife with some one of their neighbors. They retained the celebration of their renowned Olympic games till A. D. 394, when the festival was abolished by the emperor Theodosius. Two years later the country was laid waste with fire and sword by Alaric. Again in the middle ages Elis became of some importance in the hands of French adventurers, and subsequently of the Venetians. But the memory of its ancient religious character, and traditions of its cultivation and large and active population, give to it its only modern interest. Its two northern divisions now form part of the nomarchy of Achaia and Elis, and Triphylia of that of Messenia.

**ELISABETHGRAD**, or **Yelisavetgrad**, a fortified town of South Russia, in the government and 130 m. N. of the city of Kherson, on the river Ingul; pop. in 1867, 31,968. It is hexagonal in shape, fortified and well built, is the headquarters of the military colonies E. of the Bug, contains a large hospital and five churches, has considerable trade, and the principal annual fair in the government. It was founded in 1754, and named after the empress Elizabeth.

**ELISABETHPOL**. **I.** A government of Asiatic Russia, in the division of Transcaucasia, bordering on the governments of Tiflis, Baku, and Erivan, and bounded S. by Persia; area, 17,038 sq. m.; pop. in 1867, 503,282. The western portion is mountainous; the eastern is more level. The principal river is the Kur. **II.** A town, capital of the government, on an affluent of the Kur, 90 m. S. E. of Tiflis; pop. in 1867, 14,971. It has several churches and mosques, and considerable trade in fruit. Its original name was Gansha. Here Paskevitch defeated the Persians, Sept. 25, 1826.

**ELISHA**, a Hebrew prophet, whose history is given in the books of Kings. He was ploughing with twelve yoke of oxen when Elijah called him to the prophetic office. At the moment when Elijah disappeared from the earth, Elisha received his mantle, and was recognized by the other prophets as their spiritual chief. He divided the waters of the Jordan by extending over them the robe of his master; rendered the bitter fountain of Jericho

sweet by casting salt into it; cursed the children of Bethel, who mocked him, and were devoured by two bears; predicted the victory of Jehoram and Jehoshaphat over the Moabites; restored the fortune of a widow persecuted by her creditors; raised to life the son of a woman of Shunam who had given him hospitality; and cured the leprosy of Naaman. He defeated the projects of Benhadad, king of Syria, against Israel, and caused the host sent to capture himself to be struck with blindness. Samaria being reduced to extreme famine by siege, Elisha predicted incredible abundance, which was suddenly obtained by the panic and flight of the Syrian army, who left their tents filled with gold and provisions. He foretold the death of Benhadad, and the succession of Hazael, his murderer. Upon his deathbed he was visited by King Joash, to whom he promised three victories over the Syrians. His death is commonly fixed about 840 B. C.—Elisha is canonized in the Greek church; his day is June 14. Under that date the traditions concerning him are given in the *Acta Sanctorum*. In the time of Jerome his mausoleum was shown at Samaria. Under Julian his reputed bones were taken from their receptacle and burned.

**ELIXIR**, a word probably of Arabic origin, applied in old pharmacy to certain extracts obtained by boiling; as elixir of vitriol, a mixture of sulphuric acid with some aromatic tincture. In modern pharmacy the name is retained for various tinctures made up of several ingredients. The alchemists applied it to a number of solutions which they employed in the transmutation of metals, and to the *elixir vita*, a preparation which when discovered was to endow the person taking it with immortality.

**ELIZABETH**, a city and the capital of Union co., New Jersey, on Newark bay and Staten Island sound, 11 m. W. S. W. of New York; pop. in 1850, 5,583; in 1860, 11,567; in 1870, 20,832, of whom 6,752 were foreigners. It is situated on elevated ground on both sides of the Elizabeth river, a small stream emptying into the sound. It is regularly laid out, with broad streets shaded with trees, and contains several small parks and numerous handsome residences. Many retired merchants and persons doing business in New York reside here, and it has long been noted for its wealth, its good schools, and its refined society. Elizabethport, the portion bordering on the bay and sound, can be reached by vessels of 300 tons. It is the seat of nearly all the manufactories, and annually ships large quantities of coal and iron, brought by rail from the Pennsylvania mines. The railroads passing through the city are the New Jersey, the Central of New Jersey, the Newark and Elizabeth, and the Perth Amboy and Elizabethport. It is nearly connected by horse car with Newark, 5 m. distant, and a line of steamboats plies between New York and Elizabethport. The principal manufactories are 2 of cordage, 1 of

edge tools, 1 of gas machinery, 1 of carriages and spokes, 1 of boots and shoes, 2 of zinc, 1 of combs, 1 of lampblack, 1 of saws, 1 of stoves, 1 of straw hats, 1 of trunks, 2 potteries (vitrified stone drain pipe), 5 breweries, 3 planing and moulding mills, and several large iron founderies. The largest establishment is the factory of the Singer sewing machine company, one of the most extensive in the world, recently erected in Elizabethport. There are 2 national banks, with an aggregate capital of \$600,000, 3 saving banks, 1 life insurance and 3 fire insurance companies. The city is divided into eight wards, and is governed by a mayor and a common council, consisting of two members from each ward. The police force consists of a chief and 40 patrolmen. There is a volunteer fire department, and a fire alarm telegraph is in operation. The water works, owned by a private company, supply the greater portion of the city from the upper part of Elizabeth river. The city is lighted with gas, and has 24 m. of streets paved, in about equal proportions, with wooden and stone pavement, and about 27 m. of sewers. The assessed value of property (about one third of the true value) in 1873 was \$15,563,625; total taxation, \$408,994 32, of which \$268,000 were for city purposes. The debt amounted to \$600,000, besides which there were outstanding \$3,000,000 improvement bonds, for which the treasury is to be reimbursed by assessments on the property improved. The principal public buildings and institutions are the court house and county jail, the city hall, 4 public school houses, 6 hotels, the city almshouse, the orphan asylum, and the old ladies' home. The public schools (2 high, 4 grammar, and 5 primary) are under the charge of a board of 16 commissioners, and have an average attendance of about 2,500 pupils. The amount appropriated for school purposes in 1873 was \$32,000. There are a business college, a collegiate school for young men, and five other private schools. The periodicals are three daily, one semi-weekly (German), three weekly, and one monthly. There are 24 churches, viz.: 3 Baptist, 1 Congregational, 4 Episcopal, 1 German Lutheran, 1 German Moravian, 5 Methodist (1 German), 5 Presbyterian, and 4 Roman Catholic, besides a nunnery.—Elizabeth, formerly called Elizabethtown, was settled in 1665, and was the colonial capital from Feb. 24, 1755, to Sept. 13, 1757. A city charter was granted in 1865.

**ELIZABETH**, second queen regnant of England, and last sovereign of the Tudor line, daughter of Henry VIII. and Anne Boleyn, born at the palace of Greenwich, Sept. 7, 1533, died March 24, 1603. She was virtually made heiress presumptive to the throne immediately after her birth, by act of parliament, to the exclusion of her sister Mary, daughter of Catharine of Aragon, who was more than 17 years her senior. The king, though bitterly disappointed in the sex of the child, showed attach-



ment to her, and interested himself in her education. He purposed wedding her to the third son of Francis I. of France. In her third year her fortunes were clouded by the occurrence of that tragedy which sent her mother to the scaffold. Elizabeth was in her turn declared illegitimate, and fell into contempt. The birth of her only brother, afterward Edward VI., happened in 1537, and her first public act was to bear the chrism at his christening, she being herself carried in the arms of Lord Hertford. She was educated by Lady Bryan, a superior woman, and early showed talent. She became attached to her brother, and was on the best of terms with Henry's last three wives. At 10 years her hand was offered to the earl of Arran, but refused. A marriage between her and Prince Philip of Spain was talked of in 1545. The preceding year she had been restored to her right of succession, but the act declaring her illegitimate was never repealed. She already understood the Latin, French, Italian, Spanish, and Flemish languages. She translated a work from the Italian, and dedicated it to her last stepmother; but her favorite study was history. She shared the instruction received by her brother from some of the most learned men of England. Henry dying in January, 1547 (N. S.), Elizabeth found herself by his will the next person in the order of succession to Mary, and in other respects liberally provided for. Lord Seymour of Sudley, an uncle of the king, endeavored to get her for his wife; but he failed, and married Catharine Parr, Henry's last wife, at whose instance Elizabeth had rejected him. Her studies were continued, and she became the pupil of Roger Ascham, on the death of William Grindal, when she was 16. With him she read in Latin the works of Livy and Cicero, and in Greek those of Sophocles, the select orations of Isocrates, and the New Testament. Elizabeth was residing with her stepmother, and the freedom she allowed Lord Seymour caused much scandal and led to her removal to Hatfield. After his wife's death Seymour renewed his acquaintance with Elizabeth, but his arrest and execution on the charge of treason prevented the success of his designs. Elizabeth on hearing of his death merely said that there had died a man of much wit and very little judgment; words which accurately described him. She was now regarded as being in some sort the rival of Mary, and as the chief person in the Protestant party, as Mary was at the head of the Catholics; but this rivalry was ended by the plot of Dudley, duke of Northumberland, to exclude both from the throne, and to secure it for Lady Jane Grey, whom he had caused to marry one of his sons. Edward VI. was Northumberland's tool, and was not allowed to see Elizabeth in his last days. On his death the duke offered Elizabeth a large sum of money and a valuable grant of lands if she would acquiesce in the new order of things; but she referred him to Mary, during whose

life she had nothing to resign. She joined Mary soon after her success, in 1553, at the head of a body of troops. In a month however they became enemies. Mary's adherence to the Roman Catholic faith offended many of her subjects, who looked to Elizabeth as their future sovereign, the queen having passed middle life and being single. Their relative positions were sufficient to cause enmity between them, and Elizabeth's refusal to attend mass offended the sovereign and her Catholic advisers. After much quarrelling the princess affected to give way, and attended the queen at mass. Her object was to have her right to the succession admitted at the coronation, in which she succeeded. The estrangement between the sisters was however renewed when an act of parliament was passed, declaring valid the marriage between Henry VIII. and Catharine of Aragon, from which Elizabeth's illegitimacy followed, though it was not set forth in words. After considerable disagreement and contention at court, Elizabeth was allowed to retire to the country, where she refused to marry either the duke of Savoy or the prince of Denmark. Growing out of the general discontent in regard to the proposed marriage of Mary with Philip II. of Spain, there was a plot to marry Elizabeth to Courtenay, earl of Devonshire, and to elevate them to the throne. Some persons even resolved to resist the Spanish alliance by arms. Sir Thomas Wyatt undertook to raise Kent, and seemed at first successful, but soon his rebellion was put down, and some of the rebels accused Elizabeth of being in the plot, while there were other circumstances that bore against her. A royal commission was sent to remove her to London, which was done, though she was very ill. She was lodged at Whitehall, Mary refusing to see her. The royal councillors were divided, some being in favor of her execution, while others were more merciful. Finally she was sent to the tower, March 17, 1554, where she was examined. She was forced to hear mass. Wyatt exonerated her on the scaffold from being privy to his intended rebellion, but his language was ambiguous, and there seems little reason to doubt her complicity in the plot. The ambassador of Charles V., anxious for the interests of Philip, Mary's intended husband, warmly urged Elizabeth's execution. Mary would not listen to his entreaties, and soon gave orders for her sister's removal from the tower. She was sent to Woodstock, where she remained in detention for some time, and professed herself a Catholic. Mary was married to Philip II. in July, 1554, and her belief that she was to give an heir to the crown had a good effect on Elizabeth's fortunes; she was now taken to London, had an interview with the queen, and appeared publicly at court. Though treated with much respect, she was not made free until some months later, when she was allowed to reside at Hatfield, but with a sort of keeper in her household. She was visited

by the queen, and went herself to court. The object of many plots, her life continued to be unpleasant, and at one time she thought of flying to France. Overtures of marriage were made to her from various quarters, but she would not listen to them. Philip, who now treated her with marked friendship, on politic grounds, was anxious that she should marry Philibert of Savoy, but all his endeavors were fruitless, and he could not prevail upon his wife to coerce her sister's inclinations. The sisters were on good terms during the last months of Mary's life. The queen, anticipating her husband's request, declared Elizabeth her successor shortly before her death, exacting, however, a profession of adherence to the old religion. Affecting to feel hurt that her Catholicism should be doubted, the princess "prayed God that the earth might open and swallow her alive if she were not a true Roman Catholic." She declared that she prayed to the Virgin, and on the day before she became queen the Spanish ambassador wrote to his master that she had told him that she acknowledged the real presence in the sacrament. Mary died Nov. 17, 1558, and Elizabeth ascended the throne without opposition. Cecil was appointed her principal secretary of state, and Nicholas Bacon lord keeper. The queen continued to conform to the Catholic worship until Christmas morning, when she took the final step that placed her at the head of the Protestant world, by refusing to hear mass in the royal chapel. Other changes were made, but her coronation was according to the forms of Catholicism. She sent friendly messages to Protestant sovereigns, and directed her minister at Rome to assure Paul IV. that no violence should be done to the consciences of Englishmen; but the pontiff made only sharp comments on the message, declared that she was not legitimate, and required her to submit her claim, as against that of Mary Stuart, to his arbitration. She recalled her minister, whom the pope frightened into staying at Rome under the threat of excommunication. A bull was issued against Elizabeth soon after, but she was not expressly named in it. The religious change went on, though Elizabeth was averse to innovations, and would have preferred to proceed so slowly as to have virtually kept things in the state she had found them. Catholic and Protestant services were strangely mixed up in her public worship; but this could not last, and 13 bishops were deprived of their sees by parliament for refusing to take the oath of supremacy. The church of England was restored, and the use of the Bible in English was legalized. Philip of Spain sought her hand, and wrote to her often; but though she was anxious not to offend him, England being in a very depressed state, she would not accept the offer. By the treaty of Cateau-Cambrésis (April, 1559) peace was restored, France agreeing to give up Calais in eight years. Six months after her accession the Catholic service was finally discontinued

in Elizabeth's private chapel. At first she would not take the title of head of the church, assuming that of its governess; but at a later period she asserted her supremacy arbitrarily. In France the English throne was claimed for Mary, queen of Scots; a foolish pretension, destined to have bloody consequences. Elizabeth early began to interfere with Scotch affairs, and the party of the reformation was enabled to triumph there through her aid. Pope Pius IV. sought to win the queen back to the church of Rome, but unsuccessfully. She restored the currency to sterling value in 1560, a reform that did much to promote the prosperity of her subjects. Aid in money, arms, and men was sent to the French Huguenots, and secret assistance to the Protestants of Flanders. When the queen of Scots sought a safe passage from France to Scotland, Elizabeth refused her request, and it is believed that she endeavored to seize her person. In 1563 parliament entreated the queen to marry, the question of the succession being one of much interest to all classes of her subjects, who were not yet free from the terror caused by the wars of the roses. Candidates for her hand continued to spring up at home and abroad. The most prominent Englishman who aspired to the honor was Henry Fitzalan, 18th and last earl of Arundel of that name. Though she was entreated to acknowledge Mary Stuart as her heiress presumptive, she would not do so, and the question was left open. She recommended Lord Robert Dudley as a husband to Mary Stuart, before he had been made earl of Leicester, though his object was to marry herself. She was offered the hand of Charles IX. of France, but though pleased with the offer she would not accept it. Another suitor of the highest rank was the archduke Charles, son of the German emperor. Leicester approved of this match. The fortunes of this new noble were rapidly rising, and though he and the queen occasionally fell out, they were soon reconciled, and to his increased gain. Their intimacy began early, in the days of Elizabeth's adversity, and lasted until the earl's death, causing scandalous stories to obtain currency. Her marriage with the favorite was expected daily. The marriage of Darnley and Mary Stuart annoyed her; and the birth of a son from that union caused alarm in England, as showing that the crown might pass to a Catholic. Parliament being summoned in October, 1566, one of the first acts of the commons was to vote that the bill for supplies should be accompanied by one for the settlement of the succession; for this Elizabeth hotly rebuked them. Even Leicester, whose schemes had been traversed by Cecil, was one of the leaders of the opposition on this occasion. In November she was waited upon by a deputation from both houses, and entreated to marry or to name a successor. She endeavored to reason them out of their obstinacy, and as to the succession, she said, they should have the benefit of her pray-

ers. The commons were stubborn, but the dispute was compromised, the queen taking half the money without naming her successor. The murder of Darnley led to the overthrow of Mary Stuart, and to her flight to England the next year (May, 1568), when she was made Elizabeth's prisoner. Mary submitted her case to be tried by English commissioners. Serious internal troubles now began, and those from without assumed a critical character. The asylum England afforded to those who fled from persecution in Flanders offended Spain. The English flag was insulted in the gulf of Mexico, and the English minister at Madrid badly treated. The queen retaliated by seizing treasure found in Spanish vessels which had taken refuge in English ports; and when Alva laid an embargo on Englishmen and their property, she arrested all the Spaniards in England, not even excepting the ambassador. She corresponded directly with Philip II., but that monarch took a high tone, and threatened war. The duke of Norfolk had become attached to Mary Stuart, and Elizabeth bade him be on his guard. He was arrested and imprisoned. The great northern rebellion broke out (1569), headed by the Catholic earls of Westmoreland and Northumberland, but was rapidly crushed by the earl of Sussex, and 800 of the rebels were executed. In 1570 the queen was excommunicated by Pope Pius V., and a copy of the bull was fastened on the gate of the episcopal palace of London by a Catholic named Felton, who was put to the rack and executed. After the failure of another attempt to bring about a marriage between the queen and the archduke Charles, it was proposed that she should marry the duke of Anjou, afterward Henry III. of France, and last of the Valois. When the council was informed of this, one of them observed that the duke was rather young for the queen (Anjou was 20 years old, Elizabeth 37), which enraged her. In this, as in all her negotiations of a similar character, she does not seem to have been sincere; but it was always a source of anger when any one of her suitors saw fit to marry some other lady. Cecil was now created Lord Burleigh, and made lord high treasurer, and Sir Thomas Smith principal secretary of state. Hatton now began to attract attention, being high in the queen's favor because of his personal accomplishments and beauty; and her reputation has been assailed on account of her fondness for him. For his good she despoiled the bishop of Ely of much church property, and wrote him a truculent epistle in three lines. The French marriage project halting, Anjou's mother proposed his younger brother Alençon in his place, who was Elizabeth's junior by 22 years, and as ugly in person as he was morally depraved. Subsequently the negotiation with Anjou was resumed. The emperor Maximilian II. offered the hand of his son Rudolph to the queen, who was more than old enough to be his mother. Henry of Navarre was also placed

at her disposal. She favored Anjou most, but finally rejected him, ostensibly on religious grounds. Philip II. was now engaged in a plan involving the assassination of Elizabeth, with which Norfolk and Mary Stuart had some connection. It was discovered, and Norfolk was executed. The Alençon marriage project was now resumed. Parliament passed a bill to put Mary Stuart to death, but Elizabeth would not give her consent to it. Meantime, in 1572 occurred the St. Bartholomew massacre, which made the English clamorous for the death of Mary. Elizabeth would not directly consent to this; but she agreed to a project for giving Mary up to her Scottish subjects, who it was understood would at once put her to death. In 1575 the Dutch offered their government to Elizabeth, whom they respected as descended from Philippa of Hainaut. She did not at first help them, and it was not till 1578 that she agreed to aid them with money and men, on conditions by which she could not lose anything. Ireland gave her great trouble, and the contest which was waged there by Lord Mountjoy was called by the Irish "the hag's war," in derision of the queen. Conspiracies began to multiply around her, naturally having Mary Stuart for their central figure. The Jesuits were conspicuous in these plots, in one of which the Spanish minister Mendoza was implicated, and forced to leave the country. Many persons were executed and others imprisoned. Philip Howard, earl of Arundel, son of the duke of Norfolk, was condemned to death, and died in the tower after a long imprisonment. An association to protect the queen against "popish conspirators" was formed by Leicester, and was converted into a statute by parliament, which actually prepared the way for the murder of Mary Stuart, should Elizabeth be assassinated in her name. The discovery of a conspiracy, in which Anthony Babington was a leading actor, which aimed at the simultaneous assassination of Elizabeth and the liberation of Mary, proved fatal to the latter. Her trial has been the subject of bitter discussion. She was convicted of complicity in the conspiracy, and was executed at Fotheringay, Feb. 8, 1587. Elizabeth professed great grief and anger at her execution. It is now pretty well established that her signature to Mary's death warrant was a forgery, and it is beyond doubt that it was sent to Fotheringay castle without her knowledge or sanction. Burleigh was the sender of it, and the forgery is supposed to have been perpetrated by the order or under the direction of Walsingham. Angry as she was, Elizabeth dared to punish no one but the secretary Davison, who was only a tool of the higher ministers; for not only had foreign affairs assumed a serious aspect, but the killing of Mary was unquestionably a popular act with the ruling classes and party. The Scotch people were enraged, and gladly would have assailed their old enemy; but nothing was done. The condition of France

left no room for fear on that side; but the pope and the king of Spain were active enemies. Sixtus V. anathematized Elizabeth, and proclaimed a crusade against her. Philip II. laid claim to the English crown, as legitimate heir of the house of Lancaster, in virtue of his descent from two daughters of John of Gaunt, who had been queens of Portugal and Castile. He made open preparations to enforce this claim, and the pope promised large conditional aid. Meantime, Drake ravaged the coasts of Spain, preyed on her commerce, and made a successful attack on the shipping in the harbor of Cadiz. The English were not backward in preparing to meet Philip's attack. All parties, Catholics and Puritans, as well as the rest of the people, showed a patriotic spirit. A fleet of 180 sail was got ready, commanded by Lord Howard of Effingham, Drake, Frobisher, and Hawkins. Two armies were raised, numbering over 60,000 men. The Spanish armada sailed May 29, 1588, but a storm compelled it to return; and it was not till the end of July that the two fleets met and joined battle near the English coast. After a series of actions that lasted several days the Spaniards were utterly routed, the elements greatly assisting the English, whose commanders had been seriously hampered by the indecision, perverseness, and avarice of the queen, who would not supply them with provisions or ammunition in anything like sufficient quantities. The country was thus delivered from present fear of invasion. In 1589 an expedition was sent to effect the liberation of Portugal; but though the army was landed and marched to the suburbs of Lisbon, the undertaking signally failed. Aid in men and money was sent to Henry IV. of France, then contending with Spain and the league, in 1590-'91. A parliament met in 1593, and the commons after some contention with her submitted to the sovereign. The decision of Henry IV. to abandon the Protestant faith annoyed Elizabeth, and she sought to influence his mind to remain firm, but ineffectually. A plot to poison her was detected, and her physician, Roderigo Lopez, a Spaniard of Jewish extraction, who had been in her service for some years, was executed for his part in it. Religious persecutions were now common, and several noted Puritans were put to death. The war with Spain was carried on with vigor, and Cadiz was taken in 1596, by a fleet and army commanded by Howard of Effingham and Essex. The latter was now the principal subject in England, but the infirmities of his temper prevented him from profiting fully by his position and the queen's regard. The court was full of intrigues, and Essex, the most generous and imprudent of men, was the victim of all who chose to play upon him. Philip II. having formed a plan to place his daughter on the English throne, Essex was sent to assail the Spaniards at home and on the ocean. He accomplished nothing, which offended the queen; but he soon recovered her favor, and was en-

abled to beard Burleigh, until the latter discovered that he was in correspondence with the king of Scotland. Henry IV., having resolved upon peace with Spain, to the anger of Elizabeth, offered to mediate a general peace. Burleigh favored this, and Essex took the other side. In a consultation on Irish affairs, in the royal closet, Essex turned his back contemptuously on the queen, who struck him on the head, and told him to "go and be hanged!" After a display of rashness and temper the earl left the presence. While efforts for a reconciliation were making, Burleigh died, Aug. 4, 1598. Six weeks later died Philip II. Essex returned to court, and shortly after was appointed lord deputy of Ireland, which was in a miserable state. The office was given less in love than in anger, and was the gift of enemies. A politician rather than a statesman, and a knight rather than a soldier, Essex failed entirely in Ireland, whence he returned without permission and entered upon a reckless course of action that ended in his death on the scaffold in 1601. Sir Robert Cecil, a son of Burleigh, was now Elizabeth's most powerful minister, and he was in correspondence with the king of Scotland. The queen sought to have Henry IV. visit her at Dover, he being at Calais, but he contented himself with sending M. de Rosny, later the duke de Sully, as his ambassador. Their interviews were interesting, and in the first she spoke of the king of Scotland as her successor, who, she said, would be king of Great Britain. This title originated with her. Another embassy was sent to England by Henry, and was well received. Elizabeth's last parliament met in October, 1601. It made great opposition to the oppressive monopolies she had granted, and she gracefully gave way. In the early part of 1603 (N. S.) she suffered from a complication of complaints, but the immediate cause of her death, which took place at Richmond, was a cold. She was buried April 28. Her reign is justly considered one of the most important England has known. "The Elizabethan age" is one of the most brilliant periods of English history, and the numerous statesmen, soldiers, scholars, and other intellectual personages who then existed, achieved for it a place in the world's annals that has never been surpassed.—The leading events in the life of Elizabeth are unquestioned. Of her personal character various and wholly diverse views have been formed. Froude at the close of his elaborate history thus sums up his judgment respecting her: "Her situation from the very first was extremely trying. Her unlucky, it may be almost called culpable, attachment to Leicester made marriage unconquerably distasteful to her, and her disappointment gave an additional twist to her natural eccentricities. Circumstances more than choice threw her originally on the side of the reformation. She found herself compelled against her will to become the patron of heretics and rebels, in whose objects she had no

interest, and in whose theology she had no belief. She resented the necessity while she submitted to it, and her vacillations are explained by the reluctance with which each successive step was forced upon her, on a road which she detested. Her keenness of insight was not combined with any profound concern for serious things. She was without the intellectual emotions which give human character its consistency and power. One moral quality she possessed in an eminent degree: she was supremely brave. For 30 years she was perpetually a mark for assassination, and her spirits were never affected, and she was never frightened into cruelty. She had a proper contempt also for idle luxury and indulgence. She lived simply, worked hard, and ruled her household with rigid economy. But her vanity was as insatiate as it was commonplace. No flattery was too tawdry to find a welcome with her; and as she had no repugnance to false words in others, she was equally liberal of them herself. Her entire nature was saturated with artifice. Except when speaking some round untruth, she could never be simple. Obligations of honor were not only occasionally forgotten by her, but she did not even seem to understand what honor meant. Vain as she was of her own sagacity, she never modified a course recommended to her by Burghley without injury both to the realm and to herself. She never chose an opposite course without plunging into embarrassments, from which his skill and Walsingham's were barely able to extricate her. The great results of her reign were the fruits of a policy which were not her own, and which she starved and mutilated when energy and completeness were needed. That she pushed no question to extremities has been interpreted by the result into wisdom. She gained time by it, and her hardest problems were those which time alone could resolve satisfactorily. She wished only to reign in quiet till her death, and was contented to leave the next generation to settle its own difficulties. Mercy was the quality with which she was the most eager to be credited. Her tenderness toward conspirators was as remarkable as it was hitherto unexampled. Unlike her father, who ever struck the leaders and spared the followers, Elizabeth could rarely bring herself to sign the death warrant of a nobleman; yet without compunction she could order Yorkshire peasants to be hung in scores by martial law. She was remorseless when she ought to have been most forbearing, and lenient when she ought to have been stern; and she owed her safety and her success to the incapacity and the divisions of her enemies, rather than to wisdom and to resolution of her own."

**ELIZABETH**, queen of Spain, born at Fontainebleau, Nov. 22, 1602, died in Madrid, Oct. 6, 1644. She was the daughter of Henry IV. of France and Maria de' Medici, and was married to Philip, infante of Spain, Oct. 18, 1615.

Philip, having in 1621 succeeded to the crown as Philip IV., surrendered the administration to the count of Olivarez, and gave himself up to pleasure. Elizabeth made vain efforts to rouse him from his supineness, and to counteract the ruinous policy of his minister. In 1640, when Catalonia revolted, when Portugal separated from Spain, and French armies co-operated with the rebels, the queen appealed in person to the Castilians, and succeeded within a few weeks in raising an army of 50,000 men. Then, proceeding to the king's pleasure house of Buen Retiro, and holding her son by the hand, "Sir," said she, "this boy, our only son, is doomed to be the poorest gentleman in Europe, if your majesty does not forthwith dismiss a minister who has brought Spain to the verge of ruin." Olivarez was thereupon exiled, and Philip roused to momentary energy. Elizabeth broke off all relations with her own family, now become the worst enemies of Spain, and took into her own hands the administration of the kingdom, while Philip at the head of his armies vainly endeavored to retrieve his fortunes. She displayed equal wisdom and patriotism in her management of public affairs, allayed party strifes by her eloquent appeals, and set the example of generosity by sacrificing her jewels, and reducing her household expenses to the lowest figure. Her death was mourned as a national calamity.

**ELIZABETH** (Élisabeth Philippine Marie Héléne), madame, called Elizabeth of France, a French princess, sister of Louis XVI., born in Versailles, May 3, 1764, guillotined in Paris, May 10, 1794. At an early age she distinguished herself by charity and a taste for study, especially of botany. When the revolution broke out, she shared her brother's trials and misfortunes, evincing in all circumstances unflinching firmness, courage, and sweetness of temper. On Oct. 5, 1789, she succeeded in preserving the lives of several of the royal body guard, threatened by the infuriated mob; in June, 1791, she accompanied her brother to Varennes, and sustained his spirit in their dangerous journey back to Paris; on June 20, 1792, when the populace broke into the Tuileries, her life was in danger from being mistaken for the queen; and in all the perils of that period she retained her wonted composure, and thought only of the safety of her brother and his family. She was incarcerated with them in the Temple, but was separated from the king on his trial before the convention, and afterward from the queen and the dauphin; and finally, although nothing could be adduced against her except her devotion to her brother, was sentenced to death by the revolutionary tribunal. She met her fate with the patience and intrepidity which had marked all her life.

**ELIZABETH**, Saint, called Elizabeth of Hungary, landgravine of Thuringia, daughter of Andrew II., king of Hungary, born in Presburg in 1207, died in Marburg, Germany, Nov. 19, 1231. At four years of age she was betrothed

to Louis, the eldest son of Hermann, landgrave of Thuringia, and according to the custom of the age was transferred to the household of her future husband, to be educated for her expected rank. The nuptials were celebrated when she had reached her 14th year; and continuing the religious practices for which she had early been remarkable, she enlisted the aid of her husband in the charitable works which engrossed her time. Louis joined the sixth crusade, but died before reaching the Holy Land, and his death at once changed the circumstances of the landgravine. Her infant son, Hermann, was declared incapable of succeeding to his father's rule; a party was organized in behalf of Henry, brother of the late landgrave; the castle was seized, and Elizabeth with her three children was turned out of her home without provision, money, or a change of raiment. After living some time in great destitution, subsisting now by charity and now by spinning, she was sheltered by her aunt the abbess of Kitzingen, until a more suitable asylum was found in a castle offered for her use by her uncle the bishop of Bamberg. At the intercession of the friends of the deceased landgrave, Henry recalled her to the Wartburg, and acknowledged the rights of her son; but afterward, in order to live in religious seclusion, and give herself wholly to works of charity, she took up her abode at Marburg in Hesse, where she spent the remaining three years of her life. She wore beneath her garment the haircloth of St. Francis, bound herself to obey the orders of her confessor, dismissed her favorite maids when she found herself loving them too well, devoted her liberal allowance entirely to the poor, and supported herself by spinning; she ministered to the most loathsome diseases, and even received lepers into her house. Her confessor, Conrad the legate, in compliance with her own wishes, subjected her to unusual penances. She was buried with great pomp in the chapel near the hospital which she had founded in Marburg, and the report of the frequent miracles wrought at her tomb induced Gregory IX. in 1235 to add her name to the list of saints. Her shrine was for ages one of the most famous of Europe, and the altar steps before it are worn hollow by the knees of pilgrims. Her life has been written by many authors, Catholic and Protestant, in many languages. No fewer than 38 published works and 13 MSS. relating her story are catalogued by Count de Montalembert, whose biography was translated by Mary Hackett (New York, 1854). The best Protestant life of St. Elizabeth is that of Justi (Zürich, 1797; new ed., Marburg, 1835). Her husband Louis IV. was also canonized, and their lives have been written together by Simon (Frankfort, 1854).

**ELIZABETH CHARLOTTE**, duchess of Orleans, born in Heidelberg, May 27, 1652, died at St. Cloud, Dec. 8, 1722. She was a daughter of the elector Charles Louis of the Palatinate, and

so homely that a duke of Courland who had been betrothed to her refused to marry her. After embracing Catholicism she became the second wife (Nov. 16, 1671) of Philip, duke of Orleans, brother of Louis XIV. At the French court she became distinguished for her integrity and intellect, as well as for her bluntness and eccentricity. She had a cordial hatred for Mme. de Maintenon, and opposed the marriage of her son (the future regent) with Mlle. de Blois, the king's natural daughter. Saint-Simon gives an amusing account of the energetic manner in which she displayed her feelings on the occasion by slapping her son in the face in the presence of the whole court. She often attended Louis XIV. to the chase, and the king enjoyed her wit and originality and esteemed her truthful character. Her predilection for the German language and literature increased the intercourse of French with German scholars, especially with Leibnitz, one of her principal favorites. Her claims to the Palatinate, however, proved disastrous for Germany, resulting in the devastation of that country by the armies of Louis XIV. (1688-'93). She wrote various memoirs, which have been several times translated and published in France. Her posthumous letters were also translated into French from the German, and published by P. G. Brunet in 1853; and into English, edited by Holland (2 vols., London, 1867-'72).

**ELIZABETH CHRISTINA**, queen of Prussia, born in Brunswick, Nov. 8, 1715, died Jan. 13, 1797. She was a princess of Brunswick-Bevern, and a niece of the empress of Germany, and was betrothed to the future Frederick the Great, March 10, 1732. Carlyle describes her as being at that time "an insipid, fine-complexioned young lady;" and Frederick, who was compelled to marry her by his father, and who was much opposed to the match, said of her in his letters to Grumkow: "She is not at all beautiful, speaks almost nothing, and is given to pouting." The marriage ceremony, however, was performed at Potsdam, June 12, 1733; and Carlyle says that, "with the gay temper of 18 and her native loyalty of mind, she seems to have shaped herself successively to the prince's taste, and growing yearly gracefuller and better-looking was an ornament and pleasant addition to his existence." Frederick made generous provision for her, and remarked in his will: "During my whole reign she has never given me the slightest cause of dissatisfaction, and her high moral character must inspire respect and love." She wrote several works in French.

**ELIZABETH CITY**, a S. E. county of Virginia, bordering on Chesapeake bay at the mouth of James river, bounded S. by Hampton Roads, and N. by Back river; area, 50 sq. m.; pop. in 1870, 8,303 of whom 5,471 were colored. It was one of the eight original shires into which Virginia was divided in 1634. It has a fertile soil, suitable for grain and potatoes.

The chief productions in 1870 were 10,820 bushels of wheat, 78,646 of Indian corn, 6,717 of oats, 15,024 of Irish and 15,879 of sweet potatoes. There were 280 horses, 107 mules and asses, 416 milch cows, 242 other cattle, 134 sheep, and 2,121 swine. Capital, Hampton.

**ELIZABETH CITY**, the county seat of Pasquotank co., North Carolina, on Pasquotank river, 20 m. from its mouth, and 40 m. S. of Norfolk, Va.; pop. in 1870, 930, of whom 421 were colored. It communicates with Norfolk by means of the river, which is navigable by small vessels, and of the Dismal Swamp canal. It has considerable trade, chiefly in lumber and other products of the pine, and contains a flour mill, four saw mills, three schools, a weekly newspaper, and several churches. Several confederate war vessels, which had escaped to this point after the occupation of Roanoke island by the Union forces, were captured or destroyed by a fleet under Commander Rowan, Feb. 10, 1862.

**ELIZABETH FARNESE**, queen of Spain, born Oct. 25, 1692, died in 1766. She was a daughter of Edward II., prince of Parma, and of the duchess Sophia Dorothea of Neuburg. Her ungainly appearance and headstrong disposition alienated from her the affections of her mother, and her education was neglected; but those who proposed her as a consort to Philip V. in the hope of making her their tool were greatly disappointed. The king of Spain on becoming a widower in 1714 resigned himself to the guidance of the French princess des Ursins, the favorite of his late beloved queen, and desired to follow her advice in the choice of a second wife. The princess selected Elizabeth on account of her apparent disqualification for an exalted position, and she was married to the king before the end of the year. But the first act of the new queen was to cause the dismissal of the princess, and she soon gained a complete mastery over her weak-minded husband and over the affairs of Spain. By her ambition and intrigues, and the great schemes of her minister, Cardinal Alberoni, Europe was thrown into confusion. Her eldest son Don Carlos obtained possession of the Two Sicilies. (See CHARLES III. of Spain.) Carlyle, in his "History of Frederick the Great," characterizes her as "a termagant, tenacious woman, whose ambitious cupidities were not inferior in obstinacy to Kaiser Karl's, and proved not quite so shadowy as his."

**ELIZABETH ISLANDS**, a group of 16 small islands, constituting the town of Gosnold, Dukes co., Mass., lying between Vineyard sound on the S. E. and Buzzard's bay on the N. W., and extending about 16 m. S. W. from Cape Cod, from which they are separated by a narrow channel known as Wood's Hole; pop. in 1870, 99. The principal islands, commencing at the north, are Naushon, about 8 m. long by 1 to 2 m. wide; Pasque, about 2 m. long; Nashawena, 3 m.; and Cuttyhunk, 2½ m.; they are separated from each other by narrow channels.

They were discovered in May, 1602, by Bartholomew Gosnold, after whom the town is named; he called the last mentioned island Elizabeth, in honor of the queen, a name since transferred to the group. On a rocky islet situated in a pond on this island a fort and storehouse were built, and the foundations of the first colony in New England were laid. Upon the return of Gosnold, about a month later, the colonists refused to remain, and the design of effecting a settlement was abandoned. Until 1864 the group formed a part of the town of Chilmark. The islands are noted for their beauty, have a delightful summer climate, and afford rare opportunities for fishing. On the E. shore of Naushon is Tarpaulin cove, a harbor much frequented by wind-bound vessels on the passage from Boston to New York. This island, which is well wooded and contains an abundance of deer, was the favorite residence, in the early part of the century, of James Bowdoin, the diplomatist, who had here a fine mansion furnished with a large library, philosophical apparatus, and a picture gallery. It is now the property of a Boston gentleman, who has here his summer residence; and it is much resorted to by artists. Pasque and Cuttyhunk are occupied by New York clubs for boating and fishing purposes. About 2 m. N. and W. of Cuttyhunk and Nashawena is Penikese, comprising about 100 acres, formerly owned and occupied as a summer residence by John Anderson of New York, who in April, 1873, gave the island with the buildings and furniture (reserving the right of residing on a promontory of about 15 acres at the E. extremity) to Prof. Agassiz as a site for a summer school of natural history. He also gave to the institution the sum of \$50,000 as a fund for its maintenance. The school, known as the "Anderson School of Natural History," was opened in the summer of 1873, and is to be carried on in connection with the museum of comparative zoology at Cambridge.

**ELIZABETH PETROVNA**, empress of Russia, daughter of Peter the Great and Catharine I., born in 1709, died Jan. 5, 1762. After the death of her parents, her nephew, Peter II. (1727-'30), son of Alexis, and her cousin Anna Ivanovna (1730-'40), daughter of the elder brother of Peter the Great, successively occupied the throne of Russia, for which she showed little desire, the pleasures of love, as she used to say, being her supreme good. Anna appointed Ivan, son of Anthony Ulrich, duke of Brunswick, a child but a few months old, heir to the crown under the tutelage of his mother Anna, and the regency of Biron, the favorite of the empress. Thus Elizabeth was for a third time excluded from the throne of her father, but even her freedom was now menaced by the jealousy of the mother of the infant czar, who wished to get rid both of the regent and the princess, and advised the latter to take the veil. Under these circumstances her surgeon and favorite, Lestocq, brought about a con-

spiracy, which being seconded by the favor of the national Russian party, and the intrigues of the ambassador of Louis XV., terminated in a military insurrection, the overthrow of Anna and Ivan, and the proclamation of Elizabeth as empress (December, 1741). Anna and her husband, as well as many other victims, were punished by confinement, and the young prince was imprisoned in the fortress of Schlüsselburg, which he never again left; while the successive favorites of Elizabeth, like herself destitute of character and talent, ruled the court and Russia. Her vanity equalled her gross sensuality; but, though sometimes exceedingly cruel and barbarous, she often showed humanity, and even generosity. Subsequently some abler Russians obtained the management of affairs, among them Rumiantzeff, Bestuzheff, and Vorontzoff. Peter, son of her deceased elder sister Anna, duchess of Holstein-Gottorp, was appointed heir to the throne. A war with Sweden was successfully conducted, and terminated in the peace of Abo (1743). A plot against her was detected, and the parties implicated were severely punished. An army sent to assist the empress Maria Theresa against Frederick the Great contributed to the conclusion of the peace of Aix-la-Chapelle (1748). Influenced by Shuvaloff and Bestuzheff against Prussia, and mortified by a sarcasm of the witty Prussian king, Elizabeth allied herself against him with Austria and France in the seven years' war; and her armies, under Apraxin, Fermor, Soltikoff, and Buturlin, contributed not a little to the distresses of the almost isolated Prussian monarch. They won the battles of Gross-Jägerndorf and Kunersdorf, took Colberg, and even occupied Berlin. The death of the empress not only freed Frederick from a dangerous enemy, but also promised to give him in her successor, Peter III., an ardent supporter. The licentious disorder in her court lasted till her death. Razumovski, originally an obscure Cossack, successively her servant, chamberlain, and field marshal, finally became her secret husband, and is regarded as the father of three of her children. The founding of the university of Moscow and of the academy of fine arts at St. Petersburg are among her greatest merits. She patronized the fine arts, and carried on a correspondence with Voltaire, furnishing him with materials for the history of her father.

**ELIZABETH STUART**, queen of Bohemia, born in the palace of Falkland, near Edinburgh, Aug. 16, 1596, died at Leicester house, London, Feb. 13, 1662. She was a daughter of James I. of England, and a highly accomplished princess. She had many suitors, among whom the most eminent were the young king of Spain, Philip III., Charles Emanuel I., duke of Savoy, and Frederick V., elector palatine; but as a Protestant Frederick was preferred. The marriage was celebrated with great pomp in Whitehall chapel, Feb. 14, 1613. To defray part of the expenses of the ceremonies the king levied

new taxes to the extent of £20,500. The total expense amounted to about £53,000, exclusive of the bride's portion of £40,000. Her husband was the head of the Protestant interest in Germany, and when in 1619 the crown of Bohemia was tendered to him by the insurgents, she urged his acceptance of it, with the remark that he should not have married a king's daughter if he had not the courage to become himself a king. Her entrance into Prague and her coronation were magnificent pageants, but her sovereignty soon came to an end. The imperialist forces advanced into Frederick's hereditary dominions and into Bohemia, and after the battle of Prague (Nov. 8, 1620) he and his queen were compelled to flee. A refuge was offered to them by her husband's uncle Maurice of Nassau, at the Hague, where most of her children were born. One of her sons was Prince Rupert, so well known in the history of the English civil wars. Her youngest child, Sophia, afterward electress of Hanover, and ancestress of the present English royal family, was born in 1630, soon after the birth of her nephew, Charles II. Elizabeth went to England in 1660, and resided for about six months in the house of Lord Craven, whose acquaintance she made after the death of her husband (1632), and with whom she lived on terms of the greatest intimacy. Her charms are celebrated by Sir Henry Wotton, in his famous lines beginning, "You meaner beauties of the night."

**ELIZABETH OF VALOIS**, or **Isabella**, queen of Spain, born at Fontainebleau, April 13, 1545, died in Madrid, Oct. 3, 1568. She was a daughter of Henry II. and Catharine de' Medici. By a treaty concluded at Angers in 1551 she was betrothed to Edward VI. of England, but the marriage was prevented by his premature death. By the preliminaries of the treaty of peace of Cateau-Cambrésis, her hand was assigned to Don Carlos, infante of Spain. The treaty was ratified April 3, 1559; but the father of Don Carlos, Philip II., being left a widower by the death of his wife, Queen Mary of England, and fascinated by a portrait which he had seen of the French princess, substituted himself for his son. After a wedding by proxy celebrated at Paris in June, she was united to Philip in February, 1560, the marriage ceremony being performed with great splendor at Toledo. Just before her death she was delivered of a daughter, who lived only to be baptized and was buried in the same coffin with her mother. Romantic accounts have been given of the relations between Elizabeth and Carlos, but Prescott in his "History of the Reign of Philip II." proves their groundlessness.

**ELK**, a name properly applied to the alceine division of the deer of the snowy regions, constituting the genus *alces* or *alce* (H. Smith). In this genus the muzzle is very broad, and covered with hair, except a small bare spot in front of the nostrils; the upper lip is 4 in. longer than the lower, and answers for pre-



hensile purposes; the neck is thick and short, and the throat somewhat maned in both sexes; the hair is coarse, thick, and brittle; the hind legs have the tuft of hair rather above the middle of the metatarsus; the horns in the males are broad and palmated; the tail is short. The nose cavity in the skull is very large, reaching posteriorly to a line over the front of the molars; the long intermaxillaries do not reach to the very short nasals. The horns have no basal snag, the first branch being considerably above the crown. The young are not spotted, but colored like the adult. Elks live in the woods in the northern parts of both continents, but the American is by some considered a distinct species from the European. The true American elk, or moose (as it is universally called here), *Alce Americanus* (Jardine), exceeds all other existing deer in size and strength, and unites to great speed remarkable powers of endurance; it is as large



American Elk (*Alce Americanus*).

as a horse, standing 5 ft. high at the shoulders, and measuring about 7 ft. from nose to tail; the length of the latter is about a foot; the weight of the horns varies from 45 to 70 lbs., and that of the animal from 8 to 12 cwt. The moose is an awkward, clumsy, and disproportioned creature, though from its size it possesses a certain majesty when seen amid the wild scenery of its favorite haunts. The head is too large in proportion to the body for any pretension to the symmetry usually seen in the deer family; the long, tumid, and movable upper lip gives to the face somewhat of an equine expression, and the heavy ears, more than a foot long, are decidedly asinine. Audubon says, "The head forcibly reminds us of that of an enormous jackass." The eyes are deep-seated and comparatively small; under the throat there is in both sexes a tuft of coarse bristly hair attached to a pendulous gland, which is most conspicuous in the young. The

horns are found in the males only, and require five years for their full development; they begin to sprout in April, and complete their growth in July; the first year they are about an inch long; the second year, 4 or 5 in., with perhaps a rudimentary point; the third year, about 9 in., each dividing into a round fork; in the fourth year they become palmated, with a brow antler and three or four points; and the fifth year they have two crown antlers and four or five points; after this one or two points are added annually, up to as many as 23, with an expanse sometimes of nearly 6 ft. to the outside of the tips, with the palm a foot wide within the points, and a circumference above the burr of 9 in. The horns diminish in size after the animal has passed the period of greatest vigor; in old and vigorous animals they are shed in December, but young animals sometimes carry them till March. The first inner branch begins about 9 in. from the base; the palms are often unlike on the right and left sides, and are channelled irregularly on both surfaces; their color is brownish yellow, with the ends yellowish white. The incisor teeth, six in the lower jaw only, are gouge-like and very white; the eyes are black; the nose, forehead, and upper lip yellowish fawn; the sides of the head yellowish brown; the general color above varies from blackish to ashy gray; below lighter, with a yellowish white tinge. In winter the color is darker, and in advanced age so dark as to merit the name given to it by H. Smith, "the American black elk;" the grayish are said to be the largest, reaching a height of 7 or 8 ft. In summer the hair is short and soft, in winter longer and very coarse, with a fine short wool next the skin. Moose are not uncommon in the northern parts of Maine, and in Canada, Nova Scotia, and Labrador, especially in winter. In summer they frequent lakes and rivers to free themselves from insect pests, and feed upon water plants and the tender branches of overhanging trees. In winter they retire to the elevated ridges abundantly provided with maple and other hard-wood trees, on the twigs and bark of which they feed. By the elongated upper lip they pull down the branches, which they hold with their fore legs until they are stripped of the twigs; they peel off the bark by including it between the hard pad on the roof of the mouth and the lower incisors. In winter they tread down the snow, forming what are called "yards," in which are generally found a male, female, and two fawns; as the trees are stripped they tread down fresh snow, and they are fond of going always in the same tracks. They prefer the twigs of the maple, willow, buttonwood, birch, and aspen, and grasses; in captivity they will eat the food of domestic cattle. Though their flesh is coarse, it is esteemed by hunters; the nose or muffle is a special favorite, being rich, gelatinous, and juicy, when cooked like calf's head; the steaks are juicy, often tender, but seldom fat;

the flesh of yearlings is always preferred; the tongue is much relished, as are the fatty appendages to the large intestines, by the hunters, who also consider the marrow warm from the shank bones an excellent substitute for butter. The moose trots, runs, and jumps with great speed, passing through seemingly impenetrable thickets and over broken ground without apparent effort; it swims well, with only the head and part of the neck above water; it is never seen like the reindeer on the ice, except from absolute necessity; when walking on untrodden snow its feet generally sink into it to the ground. Its sense of smell is very acute, and enables it to detect an enemy at a great distance; the breaking of the smallest twig is sufficient to startle it from its hiding place. The pairing season begins in September; during October the males become furious, fighting each other whenever they meet; they run noisily through the woods, and swim lakes and rivers in pursuit of the female; at this time it is dangerous for the hunter to approach, as they do not hesitate to attack him. The young are born in May, the first time one, and two annually afterward; the females are also very fierce in defence of their calves. The males are called bulls and the females cows. The proper times for hunting the moose are in March and September; in the latter month the animals are in their prime, and in the former they are most easily taken on account of the sharp crust impeding their progress through the snow. In hunting them in March, a few small curs are useful in worrying the animal and delaying it until the hunter comes up; it is useless to pursue them through soft snow, which offers no impediment unless it be deep, when the hunter can easily overtake them on snow shoes. Many are shot from canoes on moonlight nights in September; the hunter imitates the call of the male, which, angry at the supposed intrusion of a rival, rushes to the water's edge to fight him. Slip-nooses attached to strong saplings, bent down in the moose paths to the water, will occasionally entrap a victim. The most successful way is to start them from their yards, and pursue them over the snow. When wounded and brought to bay, they defend themselves fiercely, striking with their fore feet and horns; they will frequently turn upon the hunter when not wounded, and force him to fly for his life. Moose have been domesticated, and taught to draw carts and sledges, but during the rutting season they become perfectly intractable. Their geographical distribution is extensive; they have been found at the mouths of the Mackenzie and Coppermine rivers, on the E. slope of the Rocky mountains at the sources of Elk river, and in Oregon; on the E. coast they are found from Labrador to northern New England and New York, their southern limit seeming to be 43° 30'. As in all other deer of cold and mountainous regions, there is considerable diversity in the size of the body and

the horns of the moose, according to the abundance of food in the places inhabited by them.—The European elk (*A. malchis*, Ogilby) was once found between the 53d and 65th degrees of latitude in Prussia, Poland, Sweden, Norway, and Russia, but is rarely seen at present except in the most northern of these countries; it is also found in Asiatic Siberia. The appearance is the same as that of the moose; from its long legs and overhanging lips the old authors thought that it grazed walking backward. From the great height of the shoulders above the crupper its gait is awkward and shuffling, and when running fast the hind limbs are very wide apart; its joints crack at every step, with a sound which may be heard at a considerable distance; a part of the sound is said to be made by the hoofs striking against each other. According to Hamilton Smith, the Teutonic term *elend* (miserable) was applied to this animal from its supposed frequent attacks of

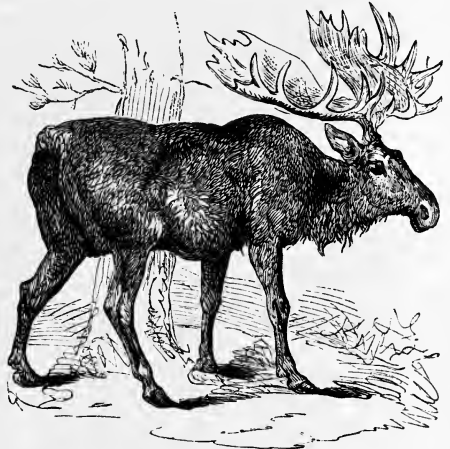

European Elk (*Alce malchis*).

epilepsy, while its falls are really attributable to its tripping itself up by treading on its fore heels, the elevated position of the nose, with the horns laid horizontally on the back, preventing it from seeing the ground distinctly before it. The European elk seems to attain a size equal to that of the moose, measuring 6 ft. high at the shoulder. The period of life is said to be about 20 years. Pennant states that elks were once used to draw sledges in Sweden, and that they could travel over 200 m. a day. Their hide makes excellent leather for belts and coverings for the feet. Though most authors have regarded the American and European elks as the same, Agassiz has described the former as distinct, with the specific name *lobatus*, from differences in the shape of the nose, the form and branching of the horns, and other points. Sir John Richardson (in the "Fossil Mammals" of the "Zoology of H. M. S. Herald") also considers the species distinct, calling the American *A. muswa*; he compares

the skeletons carefully, and mentions, among other characters, that the breadth of the face at the most protuberant part of the maxillary bones is less in the American than in the European elk; if they be regarded as the same, the proper name would be *A. Americanus* (Jardine).—The name of elk is applied in this country to the wapiti (*cervus Canadensis*, Briss.), which should be called the American stag (see WAPITI); this name is also given by the British sportsmen in India to some of the rusa or samboo deer; so that it is necessary to consider the country of the animal before deciding on the meaning of the word "elk."—There are many fossil species called elks, as the fossil or Irish elk (*cervus giganteus*, Ouv.; *megaceros Hibernicus*, Owen), found in the diluvial strata of Europe, and especially in the peat bogs of Ireland; this species was of great size, with an enormous development of horns, which, resembling those of the elk in their broad palmations, differed in the size and low situation of the basal antlers; in other parts of the skeleton it resembled most the stags. Another species, found in the peat bogs and upper tertiary of France and Germany, seems to have been a gigantic fallow deer. The fossil elk described by H. de Meyer, from the diluvium of Europe, differed from the living animal in the form of its forehead. A fossil elk, allied to the wapiti, has been found in the United States, with the bones of the mastodon. The fossil *sivatherium*, described by Cautley and Falconer, from the Sivalik hills of the lower Himalaya range, seems in many respects to have resembled the moose; the form of the head and its size lead to the belief that it was elephant-like in the cellular prominences of its posterior portion; the face was short, and the nasal bones were raised into an arch over the external nostrils, indicating the probable existence of a trunk; we see the upper lip of the moose elongated also into a kind of prehensile proboscis; the head was also armed with two spreading horns, arising above and between the orbits; the molar teeth are entirely like those of ruminants; the anterior extremities (of which casts exist in the cabinet of the Boston society of natural history) indicate an animal of the size of a large elephant. This animal was undoubtedly a ruminant, with the pachyderm characters of a heavy form, short neck, and probably a proboscis; in like manner the ruminant moose departs from the deer family, and approaches the pachyderms (especially the *equidae*) in its movable elongated snout, long ears, and general shape.

**ELK**, a N. W. county of Pennsylvania, traversed by Clarion river, its branches, and some other small streams; area, about 700 sq. m.; pop. in 1870, 8,488. The surface is broken by many hills and rough mountain peaks, the principal of which is Elk mountain, in the S. part. The county is occupied chiefly by thick forests, and lumber is the most important article of export. Bituminous coal is found in

great abundance. The soil is better adapted to grazing than to the culture of grain. The Philadelphia and Erie railroad passes through it. The chief productions in 1870 were 6,372 bushels of rye, 12,234 of Indian corn, 61,573 of oats, 35,694 of potatoes, 6,182 tons of hay, and 108,730 lbs. of butter. There were 2,953 cattle and 3,031 sheep; 2 flour mills, 36 saw mills, 4 breweries, 3 tanneries, and 3 manufacturing of carriages. Capital, Ridgeway.

**ELKHART**, a N. county of Indiana, bordering on Michigan, and watered by St. Joseph's and Elkhart rivers, which unite within its borders; area, 467 sq. m.; pop. in 1870, 26,026. The surface is moderately uneven and diversified by prairies, oak openings, and several small lakes. The soil is fertile. The Lake Shore and Michigan Southern railroad, and the Warsaw branch of the Grand Rapids and Indiana railroad, pass through it. The chief productions in 1870 were 542,042 bushels of wheat, 268,538 of Indian corn, 108,480 of oats, 148,527 of potatoes, 20,888 tons of hay, 446,269 lbs. of butter, and 71,453 of wool. There were 7,204 horses, 6,370 milch cows, 7,768 other cattle, 24,147 sheep, and 14,197 swine; 7 manufacturing of agricultural implements, 3 of boots and shoes, 5 of bricks, 13 of carriages and wagons, 13 of barrels and casks, 12 of furniture, 6 of iron castings, 1 of wrapping paper, 5 of woollen goods, 10 flour mills, 2 planing mills, and 20 saw mills. Capital, Goshen.

**ELKHART**, a town of Elkhart co., Indiana, at the confluence of the St. Joseph's and Elkhart rivers, on the Lake Shore and Michigan Southern railroad, about 80 m. E. by S. of Chicago; pop. in 1870, 3,265. It is the principal shipping point for the county. The water power is good, and the town contains several saw mills, flouring mills, and a paper mill, besides extensive machine shops of the railroad company. There are a national bank, a school building, three weekly newspapers, two monthly periodicals (one German), and several churches.

**ELKO**, the N. E. county of Nevada, bordering N. on Idaho and E. on Utah; area, 13,800 sq. m.; pop. in 1870, 3,447, of whom 439 were Chinese. The sources of the Humboldt and Owyhee rivers are in this county. The land is high and much of it suitable for farming and grazing. Silver is mined to some extent, and gold, copper, and lead are found. Three quartz mills for the production of silver are in operation. The chief productions in 1870 were 4,535 bushels of wheat, 30,560 of barley, 9,841 of potatoes, and 406 tons of hay. Capital, Elko, a station on the Central Pacific railroad.

**ELLENBOROUGH**. **I. Edward Law**, baron, chief justice of the court of king's bench in England, born at Great Salkeld, Cumberland, Nov. 16, 1750, died in London, Dec. 13, 1818. He was a son of Edmund Law, bishop of Carlisle, and was educated at the Charterhouse school in London, and at St. Peter's college, Cambridge. His abilities as a lawyer and speaker were first displayed in the trial of Warren

Hastings in 1788-'95, in which he was leading counsel for the defendant. In 1801 he was appointed attorney general, and in 1802 he succeeded Lord Kenyon as chief justice of the king's bench, on which occasion he was elevated to the peerage as Baron Ellenborough. He retired from the bench in November, 1818.

**II. Edward Law**, first earl of, an English statesman, son of the preceding, born Sept. 8, 1790, died Dec. 22, 1871. He was educated at Eton and at St. John's college, Cambridge, where he graduated in 1809. Shortly afterward he entered parliament as a member for the now disfranchised borough of St. Michael's. In 1814 he received from his father the sinecure office of clerk of the court of queen's bench, worth £7,000 a year, which he held until his death, receiving in all about £400,000 without having any duty to perform. He succeeded to the peerage as second baron in 1818, and upon the accession of the duke of Wellington to office, in 1828, he was appointed lord privy seal. During the administration of Sir Robert Peel, in 1834-'5, he became president of the board of control and first commissioner of Indian affairs, an office to which he was reappointed in September, 1841. In the following month he was appointed to succeed Lord Auckland as governor general of India. He arrived in Calcutta in February, 1842, and in April, 1844, he was recalled by the board of East India directors, contrary to the wishes of the cabinet. During his administration Scinde was annexed to the British dominions, and Gwalior reduced to subjection; but he was charged with excessive tenderness for the native troops, to the neglect of the employees in the civil service; with issuing proclamations which seemed to sanction idolatry; and with other questionable acts in his official capacity. Upon his return to England, however, he was created an earl, and in January, 1846, was appointed first lord of the admiralty, which office he held for only six months. He remained out of office until the formation of the Derby cabinet in February, 1858, when he again became president of the board of control. Early in May a despatch from him to Lord Canning, governor general of India, strongly condemnatory of the proclamation confiscating the property of the natives of Oude, was made public, and excited so much animadversion that on the 11th, after vindicating his course in a speech, he announced that rather than expose his colleagues to the censure of parliament he had resigned his office. His first wife died childless; from his second, who bore him a son who died in infancy, he was divorced. He was succeeded by his nephew, Charles Edmund, born in 1820. **III. Jane Elizabeth**, second wife of the preceding, born about 1807. She was a daughter of Admiral Digby, was married to the earl of Ellenborough in 1824, and in 1830 eloped with Prince Felix Schwarzenberg, then Austrian ambassador to England, and her marriage was dissolved by special act of parliament. She

was soon abandoned by her paramour; but by the terms of her divorce she was in possession of a large income. For years she led a gay and abandoned life in Italy and elsewhere. She was in time married to a Greek count, from whom she separated. After a while she set out on a journey to the East, and going from Palmyra to Damascus, her guard was commanded by a petty Bedouin sheik named Medjuel. She took a fancy to him, and upon their arrival at Damascus told him that she intended to marry him. He ran away; she followed him into the desert, caught him, and was married to him by the Bedouin ceremony, without other witnesses than his Arab companions. In his name she purchased a country house and gardens outside the walls of Damascus, and made it her home for a part of the year, the remainder being passed in the tent of her Bedouin husband. These events occurred about 1850. An account of a visit to her residence in Damascus in 1855 is given by Mr. W. C. Prime in his "Tent Life in the Holy Land" (New York, 1857).

**ELLERY, William**, one of the signers of the Declaration of Independence, born in Newport, R. I., Dec. 22, 1727, died there, Feb. 15, 1820. He graduated at Harvard college in 1747, and became a merchant in Newport; was naval officer of the colony of Rhode Island; and in 1770 he commenced the practice of the law. In May, 1776, he was elected to the memorable congress of that year as one of the delegates from Rhode Island, and with his colleague, Stephen Hopkins, he set his name to the Declaration of Independence. He remained in congress till 1786, with the exception of the years 1780 and 1782; and as a member of the marine committee, and subsequently of the board of admiralty, he exercised considerable influence. The plan of fire ships to be fitted out at Newport has been attributed to him. In April, 1786, he was elected by congress commissioner of the continental loan office for the state of Rhode Island, and in 1790 was appointed by Washington collector of Newport, an office which he held until his death. A biography of him by his grandson, Edward T. Channing is contained in Sparks's "American Biography," vol. vi.

**ELLESMERE, Francis Egerton**, earl of, an English nobleman, born in London, Jan. 1, 1800, died there, Feb. 18, 1857. He was the second son of the first duke of Sutherland, and until the death of his father was known as Lord Francis Leveson-Gower. He was educated at Eton, and at Christchurch, Oxford, left the university in 1820, and in 1822 entered parliament as a liberal conservative and a supporter of Canning, and became one of the earliest and most earnest advocates of free trade. He also supported the project for establishing the university of London, and on one occasion carried a motion through the house of commons for the endowment of the Roman Catholic clergy of Ireland. In 1827 he was a lord of the trea-

sury; from January, 1828, to July, 1830, he was chief secretary for Ireland; and from July to November, 1830, he was secretary at war. In 1833, upon the decease of his father, he came into possession of the immense estates of the late duke of Bridgewater, and of the picture gallery, valued at £150,000, which had been bequeathed to the duke of Sutherland, with reversion to his second son; on which occasion he assumed the name of Egerton in the place of his patronymic of Leveson-Gower. In 1835 he was elected member of parliament for South Lancashire, and represented that constituency till 1846, when he was raised to the peerage as earl of Ellesmere, after which he retired from active political life. In 1841 he was elected rector of the university of Aberdeen. While a student at the university he printed a volume of poems for private circulation; but his first public appearance as an author was in 1824, when he published a translation of "Faust," with versions of popular lyrics from the works of Goethe, Schiller, and other German poets. He subsequently produced "Mediterranean Sketches" (London, 1843), containing "The Pilgrimage," a poem which records the author's tour in Palestine; "The two Sieges of Vienna by the Turks" (1847); "Guide to Northern Archaeology" (1848); "Life and Character of Wellington" (1852); and a number of poems and plays printed for private circulation. "The Pilgrimage," after having been withheld from general circulation for many years, was republished in 1856 with a number of additional poems. In 1853 Lord Ellesmere visited the United States.

**ELLET, Charles, jr.**, an American engineer, born at Penn's Manor, Pa., Jan. 1, 1810, died at Cairo, Ill., June 21, 1862. He planned and built the first wire suspension bridge in the United States, that across the Schuylkill at Fairmount, Philadelphia, the first suspension bridge across the Niagara below the falls, and the first one at Wheeling, Va. He was employed in many other important engineering works, and in 1846-'7 was president of the Schuylkill navigation company. During the civil war he urged upon the government the construction of steam rams for use on the large rivers of the west, and after his plans had been rejected by the navy department he presented them to the secretary of war, by whom they were approved. He was commissioned as colonel of engineers, and converted several powerful light-draught steamers on the Mississippi river into rams. With these he engaged in the naval battle off Memphis, June 4, 1862, and sank or disabled several of the confederate vessels. During the battle he was wounded above the knee by a musket ball, from the effects of which he died. He was the author of "The Mississippi and Ohio Rivers," containing plans for their improvement and the protection of the delta (8vo, Philadelphia, 1853), &c.

**ELLET. I. William Henry**, an American chemist, born in New York about 1804, died there,

Jan. 26, 1859. He graduated at Columbia college in 1824. While pursuing his medical studies he gained a gold medal for a dissertation on the compounds of cyanogen. In 1832 he became professor of experimental chemistry in Columbia college, and in 1835 of chemistry, mineralogy, and geology in the South Carolina college. In 1848 he returned to New York, where he resided until his death. The legislature of South Carolina presented him with a service of silver plate for the discovery of a new and cheap method of preparing gun cotton. During the last five years of his life he was consulting chemist of the Manhattan gas company of New York. **II. Elizabeth Fries Lummis**, an American authoress, wife of the preceding, born at Sodus Point, on Lake Ontario, N. Y. She has published a volume of poems (1835), "Scenes in the Life of Joanna of Sicily" (1840), "Characters of Schiller" (1841), "Women of the American Revolution" (1848), "Evenings at Woodlawn," "Family Pictures from the Bible" (1849), "Domestic History of the American Revolution" (1850), "Watching Spirits" (1851), "Pioneer Women of the West" (1852), "Novellettes of the Musicians" (1852), "Summer Rambles in the West" (1853), "Women Artists in all Ages and Countries" (1861), "Queens of American Society" (1867), and "Court Circles of the Republic" (with Mrs. R. E. Mack, 1869). She also edited "The Practical Housekeeper," and has contributed largely to periodicals.

**ELLCOTT. I. Andrew**, an American astronomer and civil engineer, born in Bucks co., Pa., Jan. 24, 1754, died at West Point, N. Y., Aug. 28, 1820. His father, a Quaker, having united with a brother in the purchase of a large tract of wild land on the Patapasco river, in 1774 founded the town of Ellicott's Mills (now Ellicott City), in Maryland, where the younger days of his son were devoted to the study of the sciences and practical mechanics. His scientific attainments early attracted attention, and he enjoyed the friendship and confidence of Washington, Franklin, and Rittenhouse. At various times he was appointed commissioner for marking parts of the boundaries of Virginia, Pennsylvania, and New York. About 1785 he removed to Baltimore, and represented that city in the state legislature. In 1789 he was appointed by Washington to survey the land lying between Pennsylvania and Lake Erie, and during that year he made the first accurate measurement of the Niagara river from lake to lake, with the height of the falls and the descent of the rapids. In 1790 he was employed by the government to survey and lay out the federal metropolis. In 1792 he was made surveyor general of the United States, and in 1795 he superintended the construction of Fort Erie at Presque Isle (now Erie, Pa.), and was employed in laying out the towns of Erie, Warren, and Franklin. In 1796 he was appointed by Washington commissioner on behalf of the United States, under the treaty of

San Lorenzo el Real, to determine the southern boundary separating the United States territory from the Spanish possessions. The results of this service, embracing a period of nearly five years, appear in his "Journal" (4to, with 6 maps, Philadelphia, 1803). Upon the completion of this service he was appointed by Gov. McKean of Pennsylvania secretary of the state land office, from which he retired in 1808, and in 1812 he became professor of mathematics at West Point, a post which he occupied till his death. In 1817, by order of the government, he went to Montreal to make astronomical observations for carrying into effect some of the articles of the treaty of Ghent. He was an active member of the American philosophical society, and maintained correspondence with the learned societies of Europe; but with the exception of his "Journal," contributions to philosophical societies, and a few other writings, his works are yet in manuscript.

**II. Joseph**, brother of the preceding, born in Pennsylvania, died in Batavia, N. Y., in 1826. In 1790 he assisted his brother Andrew in laying out the city of Washington, and in 1791 was appointed to run the boundary line between Georgia and the Creek Indians; and for a long period, embracing the most active portion of his life, he was engaged in the service of the Holland land company. He was identified with the great public improvements of the state of New York.

**ELLCOTT, Charles John**, an English prelate and author, born at Whitwell, near Stamford, April 25, 1819. He graduated at St. John's college, Cambridge, in 1841, and was rector of Pilton, Rutlandshire, from 1848 to 1858, when he succeeded Dr. Trench as professor of divinity in King's college, London. In 1860 he became Hulsean professor of divinity at Cambridge, in 1861 dean of Exeter, and in 1863 bishop of Gloucester and Bristol. His works are: "Treatise on Analytical Statics" (1842); "History and Obligation of the Sabbath" (1844); "Critical and Grammatical Commentaries" on the epistles of St. Paul to the Galatians, Ephesians, Philippians, Colossians, Thessalonians, and Philemon, and on the "Pastoral Epistles" (1854-'61); "Lectures on the Life of our Lord Jesus Christ" (1860); and "Considerations on the Revision of the English Version of the New Testament" (1870). He has also published many addresses, lectures, sermons, and charges. His commentaries are highly esteemed, and are used as text books in English and American seminaries.

**ELLCOTT CITY** (formerly **ELLCOTT'S MILLS**), the county seat of Howard co., Maryland, situated on both sides of the Patapsco river, partly in Baltimore co., about 10 m. W. of the city of Baltimore and on the Baltimore and Ohio railroad; pop. in 1870, 1,722, of whom 355 were colored. The water power is excellent, and supplies several flour mills and manufactories. The town is the seat of St. Charles college (Roman Catholic), organized in 1848, which in

1871 had 12 professors and instructors, 180 students, and a library of 4,000 volumes. Rock Hill college, also a Roman Catholic institution, organized in 1857, had in 1872 22 professors and instructors, 156 students, and a library of 6,800 volumes. The town was settled in 1774 by the brothers Andrew and John Ellicott, whose large flouring mills here at one time held precedence in extent and perfection over all similar establishments in the country. It was incorporated under its present name in 1867.

**ELLIOT, George Thomson**, an American physician, born in New York, May 11, 1827, died there, Jan. 29, 1871. He received his academic education at Columbia college, graduated in medicine at the university of New York in 1849, and subsequently spent three years in professional study abroad, during which period he was resident interne in the lying-in hospital of Dublin, and of the royal maternity hospital in Edinburgh. Upon his return in 1852 he was made resident physician to the New York lying-in asylum, and in 1854 attending physician to the Bellevue hospital. In 1858 and 1859 he was lecturer on operative midwifery in the college of physicians and surgeons, New York, and in 1861 became professor of obstetrics and diseases of women and children in the Bellevue hospital medical college, an institution of which he was one of the founders. He wrote much for medical journals, but his principal work was "Obstetric Clinic" (1868), giving the results of midwifery cases selected from his own practice. On June 26, 1870, he had a severe attack of apoplexy with hemiplegia, which came on while he was engaged upon a case of operative midwifery. From this he partially recovered, but on Jan. 28, 1871, he had a second attack, which proved fatal.

**ELLIOTSON, John**, an English physician and physiologist, born in London about 1790, died there, July 29, 1868. He was educated at Jesus college, Cambridge, studied medicine and surgery in Edinburgh, and at St. Thomas's and Guy's hospitals in London, and in 1822 was elected physician to the former institution. Subsequently he became lecturer on the practice of medicine in St. Thomas's hospital, and in 1831 professor of the principles and practice of medicine and of clinical medicine in University college, London, in connection with which three years later he established a hospital, when he resigned his professorship at St. Thomas's. As a lecturer he obtained great popularity, though in attempting to reform the old routine of the hospitals he incurred the hostility of many of the profession. He was the founder and president of the phrenological society, and the president of the royal medical and surgical society. He had many disputes with members of the profession with regard to the use of certain remedies, now established, and advocated mesmerism as a remedy in some diseases and an agent for allaying pain in surgical operations. The unwilling

ingness of his medical colleagues and of the council of the university to allow the mesmeric cure to be applied to the hospital patients induced him, in December, 1838, to sever his connection with University college; and in 1849 a mesmeric hospital was founded, of which he was physician. A mesmeric journal, called "The Zoist," was also established by him. His principal contributions to medical science are: a translation with voluminous notes of Blumenbach's "Physiology" (1817); "Lectures on Diseases of the Heart" (1830); "Human Physiology" (1835-'40); "Principles and Practice of Medicine" (1840); and "Surgical Operations without Pain" (1843).

**ELLIOTT**, an E. county of Kentucky, drained by Little Sandy river and the N. fork of the Licking; pop. in 1870, 4,433, of whom 22 were colored. The surface is broken by hills containing coal and iron ore. The chief productions in 1870 were 8,261 bushels of wheat, 171,389 of Indian corn, 21,600 of oats, and 12,024 of potatoes. There were 908 horses, 1,083 milch cows, 2,129 other cattle, 6,835 sheep, and 6,493 swine. Capital, Sandy Hook, or Martinsburg.

**ELLIOTT**, Charles, D. D., an American clergyman, born at Greenconway, county Donegal, Ireland, May 16, 1792, died at Mount Pleasant, Iowa, Jan. 6, 1869. In his youth he became a member of the Wesleyan Methodist society, and soon after began a course of study preparatory for the ministry. In 1815 he emigrated to America, and went to Ohio, where he was received into the travelling connection of the Ohio conference in 1818. In 1822 he was appointed superintendent of the mission among the Wyandot Indians at Upper Sandusky, was subsequently for five years presiding elder of the Ohio district, and was then elected professor of languages in Madison college, Uniontown, Pa., where he remained four years. In 1831 he was stationed in Pittsburgh, and was subsequently presiding elder of that district. While serving in this capacity he was chosen editor of the "Pittsburgh Conference Journal," and afterward of the "Western Christian Advocate," at Cincinnati, where he remained till 1848. He again entered the regular work of the ministry, but in the general conference of 1852 he was re-elected editor of the "Western Advocate." From 1857 to 1860 he was professor of Biblical literature and president of the Iowa Wesleyan university. He was then appointed editor of the "Central Christian Advocate" at St. Louis, Mo., and during the civil war strongly sustained the cause of the Union. After its close he was again connected with the Iowa university till 1866. His chief works are: "Treatise on Baptism" (1834); "Delineation of Roman Catholicism" (2 vols. 8vo, 1851); "Life of Bishop Roberts" (1853); "History of the Great Secession from the Methodist Episcopal Church" (1855); "Political Romanism" (1859); "Reminiscences of the Wyandotte

Mission;" "Southwestern Methodism;" and two works against slavery.

**ELLIOTT**, Charles Loring, an American painter, born in Scipio, N. Y., in December, 1812, died in Albany, Aug. 25, 1868. He was for some time employed in a country store, but that occupation being distasteful to him, his father, who was an architect, allowed him to study drawing with a view to that profession. Elliott went to New York and became a pupil of Trumbull, and subsequently of Quidor, a painter of fancy pieces, with whom he remained long enough to acquire a knowledge of the technicalities of his art. His chief employment for some time was copying prints in oils, and he afterward attempted portraits. Some of his paintings representing scenes from Irving's and Paulding's works attracted attention. After about a year's residence in New York he returned to the western part of the state, where he practised portrait painting for about ten years. Returning to New York in 1845, he established himself there as a portrait painter, and soon rose to the head of his profession. He painted about 700 portraits, many of them of prominent persons, and all remarkable for fidelity of likeness and vigorous coloring. Not long before his death he established his studio and residence in Albany.

**ELLIOTT**, Charles Wyllis, an American author, born in Guilford, Conn., May 27, 1817. He is a lineal descendant in the fifth generation from Eliot the "Indian Apostle." After some years spent in mercantile life in the city of New York, he in 1838-'9 studied horticulture and landscape gardening with A. J. Downing at Newburgh, and from 1840 to 1848 practised those pursuits at Cincinnati. He then returned to New York and engaged in mercantile business, but devoted attention to literary pursuits. He was one of the founders and first trustees of the "Children's Aid Society" in 1853. In 1857 he was appointed one of the commissioners for laying out the Central park in the city of New York. He has published "Cottages and Cottage Life" (1848); "Mysteries, or Glimpses of the Supernatural" (1852); "St. Domingo, its Revolution and its Hero, Toussaint l'Ouverture" (1855); "The New England History, from the Discovery of the Continent by the Northmen, A. D. 986, to 1776" (2 vols., 1857); "Remarkable Characters and Places in the Holy Land" (1867); and "Wind and Whirlwind, by Thom Whyte" (1868). He has also been a frequent contributor to periodicals, and is the author of several novels published anonymously. He is now (1874) a resident of Cambridge, Mass., and manager of the "Household Art Company" of Boston.

**ELLIOTT**, Ebenezer, an English poet, called "the corn law rhymer," born at Masborough, near Rotherham, Yorkshire, March 17, 1781, died near Barnsley, Dec. 1, 1849. His father, who was employed in a foundry near Masborough, was a dissenter of what was called the Bercan sect, an occasional preacher, and a forcible

ble political speaker of the ultra radical type. Young Elliott received the education usually afforded to boys of his condition, but at school was noted for little else than dulness and laziness. He was unable to master the rudiments of grammar or arithmetic, and often gratified an instinctive love for nature and solitude by stolen rambles in the meadows and woodlands. His father consequently set him to work in the foundry. He was beginning to fall into dissipated habits when the perusal of a treatise on botany revived his love of nature, and he became an industrious collector of botanical specimens. He also procured access to a small library of the old divines and poets, and in his 17th year produced his first published poem, "The Vernal Walk," which was followed by "Night," "Wharnccliffe," "Love," and others. His powers increased with each new work, and he attracted the notice of Southey, to whose kind offices he was accustomed to refer with affection and gratitude. He had meanwhile worked steadily till his 23d year in the foundry, which his father had purchased on credit, and having married set up at Rotherham in the iron business on his own account, but was unsuccessful. At 30 years of age he became an earnest advocate of the laboring classes. The corn laws in particular struck him as unjust, and upon his failure in business he attributed his misfortunes to their influence. In 1821 he made another venture as an iron merchant in Sheffield, with a borrowed capital of £100, and was soon embarked in a lucrative business. He now commenced his "Corn Law Rhymes," which were written with the sole purpose of procuring the repeal of the obnoxious laws. At first published in a local paper and afterward collected in a single volume, these poems brought Elliott into notice. "The Ranter," which succeeded, was a long poem in a similar vein. In 1829 appeared his "Village Patriarch," the best of his larger pieces. In 1833 he commenced a complete edition of his works, which appeared during the next two years, and for the first time made generally known many of the author's poems not of an exclusively political character. Several other editions appeared in the course of his life, and to the last he continued to write verses, chiefly for the periodical press, and occasionally spoke in support of his peculiar views. The commercial panic of 1837 entailed serious pecuniary losses upon him, but by careful management he was enabled in 1841 to retire from business with a competency and settle at a villa near Barnsley, where he passed the last years of his life in pleasant seclusion. Soon after his death was published "More Prose and Verse by the Corn Law Rhymer" (2 vols., London, 1850), and his "Autobiography," in the "Athenæum" (January, 1850).

**ELLIOTT, Jesse Duncan**, an American naval officer, born in Maryland, July 14, 1782, died in Philadelphia, Dec. 18, 1845. He entered the service as a midshipman in April, 1804, and was promoted to a lieutenant April 23,

1810. In 1812 he was attached to the command of Commodore Isaac Chauncey at Sackett's Harbor, and on the declaration of war against Great Britain was sent by him to the upper lakes to purchase vessels, and make other preparations for the creation of a naval force in those waters. While he was at Black Rock, engaged in this service, two armed British brigs, the *Detroit* and *Caledonia*, anchored, Oct. 7, 1812, near the opposite shore under the guns of Fort Erie. A boat expedition was organized under Elliott's command, and the vessels were boarded and carried with but slight loss a little after midnight, Oct. 8. The *Caledonia* was safely brought over to the American side; but the *Detroit* was compelled to drop down the river, passing the British batteries under a heavy fire, and afterward was burned by the Americans, most of her stores having first been removed. For this exploit Elliott was voted a sword by congress. In July, 1813, he was promoted to the rank of master commandant, and appointed to the *Niagara*, a brig of 20 guns, on Lake Erie. In Perry's engagement with the British squadron, Sept. 10, 1813, Elliott was second in command, and a gold medal was voted him by congress for his conduct on the occasion. In October he succeeded Perry in command on Lake Erie, and in 1815 he commanded the Ontario sloop of war, one of the squadron of Commodore Decatur employed against Algiers. He was promoted to the rank of captain, March 27, 1818, and till 1824 was engaged in selecting sites for dockyards, lighthouses, and fortifications on the coast of North Carolina. From 1829 to 1833 he was in command of the West India squadron, and in the latter year of the Charlestown navy yard. Afterward he commanded for several years the Mediterranean squadron. His conduct in this position did not meet the approval of the executive, and resulted in his trial by court martial in June, 1840, and suspension from duty for four years. In October, 1843, the period of his suspension which then remained was remitted by the president, and he was appointed to the command of the Philadelphia navy yard.

**ELLIOTT. I. Stephen**, an American naturalist, born in Beaufort, S. C., Nov. 11, 1771, died in Charleston, March 28, 1830. He graduated at Yale college in 1791, and two years later was elected a member of the legislature of South Carolina, a position which he retained until the establishment of the "Bank of the State" in 1812, of which he was chosen president. He retained this office till his death. His leisure was devoted to literary and scientific pursuits, and he cultivated the study of botany with enthusiasm. In 1813 he was instrumental in founding the literary and philosophical societies of South Carolina, of each of which he was president. He lectured gratuitously on his favorite science, and was for some time chief editor of the "Southern Review," to which he contributed a number of articles. In



1825 he aided in establishing the medical college of the state, and was elected one of the faculty, and professor of natural history and botany. He is the author of "The Botany of South Carolina and Georgia" (2 vols. 8vo, Charleston, 1821-'4), in the preparation of which he was assisted by Dr. James McBride, and left a number of works in manuscript. His collection in the several departments of natural history was at the time of his death one of the most extensive in the country. The degree of LL. D. was conferred upon him by Yale and Harvard colleges. **II. Stephen**, son of the preceding, bishop of the Protestant Episcopal church for the diocese of Georgia, born at Beaufort, S. C., Nov. 13, 1805, died in Savannah, Dec. 21, 1866. He graduated at Harvard college in 1824, practised law in Charleston and Beaufort till 1833, and was ordained a deacon in 1835, and a priest in 1836, soon after which he became professor of sacred literature in the South Carolina college. In 1840 he was elected bishop of Georgia.

**ELLIOTT, William**, an American author and politician, born in Beaufort, S. C., April 27, 1788, died there in February, 1863. He was entered in Harvard college at the age of 18, but ill health compelled him to return home before the completion of his studies. For many years he devoted himself to the management of his estates, and served in both branches of the state legislature. During the nullification crisis in South Carolina in 1832 he was a senator in the state legislature, but resigned upon being instructed by his constituents to vote to nullify the tariff law. He afterward participated less frequently in public affairs, his letters against secession signed "Agricola," and published in 1851, being among his latest expressions of opinion on political subjects. He contributed largely to the periodical press of the south. He published "Address before the St. Paul's Agricultural Society" (1850), "Fiesco," a tragedy (1850), "Carolina Sports by Land and Water" (1856), and several occasional poems.

**ELLIPSE**, an oval figure produced from the section of a cone by a plane which cuts both sides of it in an oblique direction. It may also be obtained by letting the shadow of a circle fall on a plane; or it may be drawn by driving two pins into a board to mark the foci, putting a loose loop of inelastic thread over them, and drawing the curve with a pencil placed inside the loop and stretched out as far as the loop will allow. Instruments to describe an ellipse are called ellipsographs or elliptographs. The foci of an ellipse are the given points around which another point is conceived to move in such a manner that the sum of their distances from it is always the same; the line thus described is an ellipse. The centre of an ellipse is the point which bisects the straight line between the foci. The distance of either focus from the centre is called the eccentricity. A straight line passing through the centre, and

terminated both ways by the ellipse, is called a diameter. The diameter which passes through the foci is called the transverse axis, also the greater axis. The ellipse is the projection of a circle; the curve which is everywhere equally distant from the sum of the foci is an ellipse. Kepler announced the law that planetary orbits are ellipses, and upon the three simple formulas which he laid down for the solution of this problem is based all that has been done since to determine the movements of the planets. The ellipse, and the ellipsoid, which is a solid figure all plane sections of which are ellipses or circles, enter largely into mechanical contrivances. The method given above of describing an ellipse is applied in machines to turn wood and other substances into elliptic forms. An instrument similar to the elliptograph is employed for engraving ellipses on metals, and for dividing these ellipses accurately, so as to give the perspective representation of a circle divided into equal parts.

**ELLIS. I. A N.** county of Texas, drained by Trinity river, which forms its E. boundary; area, 1,000 sq. m.; pop. in 1870, 7,514 of whom 1,506 were colored. The surface is occupied by prairies and tracts of hard timber. The prairies are very fertile. The chief productions in 1870 were 11,943 bushels of wheat, 312,843 of Indian corn, 16,076 of oats, and 2,960 bales of cotton. There were 7,387 horses, 3,892 milch cows, 21,211 other cattle, 3,007 sheep, and 8,171 swine. Capital, Waxahachie. **II. A W.** central county of Kansas, intersected by Smoky Hill and Saline rivers and Big creek; area, 900 sq. m.; pop. in 1870, 1,336. The Kansas Pacific railroad passes through it. Capital, Rome.

**ELLIS, George**, an English author, born in 1745, died in April, 1815. He commenced his literary career as a writer of political satires, and became favorably known as a contributor to the "Rolliad," and subsequently to the "Anti-Jacobin." The study of early English literature, however, occupied his leisure hours, and in 1790 he produced "Specimens of Ancient English Poetry," of which enlarged editions appeared in 1801 and 1811. A companion work, "Specimens of Ancient English Romances," appeared in 1805 (3 vols. 8vo), and has been republished in Bohn's "Antiquarian Library" (London, 1848).

**ELLIS, George Edward, D. D.**, an American clergyman, born in Boston, Aug. 8, 1814. He graduated at Harvard college in 1833, studied theology at the Cambridge divinity school till 1836, and after a year's travel in Europe was ordained in 1840 as pastor of the Harvard church, Charlestown, Mass., and resigned Feb. 22, 1869. From 1857 to 1864 he was professor of doctrinal theology in the Cambridge divinity school. In 1864 he delivered a course of Lowell lectures on the evidences of Christianity. He wrote the lives of John Mason, Anne Hutchinson, and William Penn, in Sparks's "American Biography," and in 1857 pub-

lished a very elaborate work, "The Half Century of the Unitarian Controversy." He edited for a time the "Christian Register," the religious newspaper of the Massachusetts Unitarians; and for some years, in connection with the Rev. Dr. George Putnam, he conducted the "Christian Examiner." He has published many sermons and addresses, and has contributed largely to various periodicals, most frequently upon topics of American history. He is also the author of "The Aims and Purposes of the Founders of Massachusetts" (1869), "Memoir of Jared Sparks" (1869), and "Memoirs of Sir Benjamin Thompson, Count Rumford" (1871).

**ELLIS, George James Welbore Agar**, Lord Dover, an English author, born Jan. 14, 1797, died July 10, 1833. He was the son of Henry Welbore, afterward Viscount Clifden; was educated at Christchurch, Oxford; represented various constituencies in the house of commons, and was raised to the peerage as Baron Dover in 1831. He was a munificent patron of the fine arts, and in 1832 was president of the royal society of literature. He wrote "The true History of the Man in the Iron Mask," "Historical Inquiries respecting the Character of Edward Hyde, Lord Clarendon," and a "Life of Frederick the Great." He also edited the "Ellis Correspondence," and "Horace Walpole's Letters to Sir Horace Mann."

**ELLIS, Sir Henry**, an English author and antiquary, born in London, Nov. 29, 1777, died Jan. 15, 1869. He graduated at St. John's college, Oxford, in 1799, in 1805 became one of the assistant librarians of the British museum, and was head librarian from 1827 to 1856. A new and enlarged edition of Brand's "Popular Antiquities" was issued under his care in 1813, and was republished in a cheaper form in 1842. In 1816 he wrote a careful and elaborate introduction to the "Domesday Book," and in 1824 published a series of "Original Letters illustrative of English History," from autographs in the British museum, in 3 vols. 8vo; a second series, in 4 vols., in 1827; and a third, in 4 vols., in 1846. He was also the author of works on the Towneley and on the Elgin and Phigalean marbles (each 2 vols. 8vo, 1833 and 1836), and compiled and edited several valuable volumes for the society of antiquaries and for the Camden society. He received the Hanoverian Guelphic order of knighthood in 1833.

**ELLIS. I. William**, an English missionary and author, born in London in 1794, died there, June 9, 1872. In 1815 he became connected with the London missionary society, under whose auspices, in January, 1816, he sailed for Polynesia. He spent eight years in promoting the spiritual welfare of the natives of the South sea islands (at one of which, Tahiti, he erected the first printing press in Polynesia), and in 1824 returned to England on account of the illness of his wife, stopping for some time on the way in the United States. For some years he

was employed in the business of the London missionary society at home, and published "Narrative of a Tour through Hawaii" (London, 1826); "Polynesian Researches" (2 vols. 8vo, 1828); "History of Madagascar," compiled from information received from missionaries and government documents (2 vols., 1838); "History of the London Missionary Society" (1844); "Village Lectures on Popery" (1851), &c. In 1835 his wife died, and two years later he was married to Sarah Stickney, with whom he resided many years in Hoddesdon, Hertfordshire, where Mrs. Ellis conducted a school for girls. In 1853 he went to Madagascar on a mission of observation for the London missionary society, and after two other visits to that island published "Three Visits to Madagascar, during 1853-'6, with Notices of the People, Natural History, &c." (London, 1858). A memoir of Mr. Ellis by his son was published in 1873.

**II. Sarah Stickney**, an English authoress, wife of the preceding, born in London in 1812, died there, June 16, 1872. Her parents belonged to the society of Friends. Her first literary production was a didactic work for the young, entitled "The Poetry of Life." She subsequently wrote many volumes devoted to the moral and mental culture of her sex. The principal of these are: "Home, or the Iron Rule," a series entitled "The Women of England" (1838), "The Daughters of England" (1842), "The Wives of England" (1843), and "The Mothers of England" (1843); "Look to the End" (2 vols., 1845); "Hearts and Homes" (3 vols., 1848-'9); "Mothers of Great Men" (1860); "The Brewer's Family" (1863); "Education of the Heart" (1869); and "The Melvill Family" (1871).

**ELLIS, William**, an English writer on social science, born in London in 1800. In 1846 he procured the introduction of social science as a branch of elementary education in the London schools, and is the author of "Progressive Lessons in Social Science," "The Phenomena of Industrial Life," "Education as a Means of preventing Destitution," &c. He has written several articles on these subjects for periodicals.

**ELLISTON, Robert William**, an English actor, born in London, April 7, 1774, died there, July 7, 1831. He was educated at St. Paul's school, but at the age of 17 ran away and joined a theatrical company at Bath, where he made his first appearance on the stage April 21, 1791. Five years later he made his debut in London, at the Haymarket theatre, and in 1803 became principal actor and acting manager of that house. In the succeeding year he was engaged at Drury Lane, but after the burning of the theatre, having quarrelled with Thomas Sheridan, he left the company, and opened the Surrey theatre. On the rebuilding of Drury Lane he was again engaged as a leading actor, and recited the address written by Lord Byron for the opening night. In 1819 he became the lessee of Drury Lane, but in 1826 retired a bankrupt. Subsequently he was

again manager of the Surrey theatre, and continued occasionally to perform his principal characters until the close of his life. He was called the first comedian of his time. His chief merit perhaps was the facility with which he adapted himself to every variety of characters, from the humorous to the tragic. He possessed inordinate self-esteem, and many anecdotes are told of his eccentricities.

**ELLORA, Elora, or Elouro**, a decayed town of Hindostan, in the Nizam's dominions, 13 m. N. W. of Aurungabad, celebrated for its cave temples, excavated from the inner slope of a crescent-shaped hill of red granite and black and gray basalt, about a mile from the town. These caverns are sculptured over an extent  $1\frac{1}{2}$  m. in length, and may be regarded as a Hindoo pantheon, since every divinity of India has there a shrine. Most of the caves are not less than 100 ft. in depth; 20 of them are conse-

designs and sculptures representing lions, tigers, elephants, and fantastic animals of all sorts. Within are 42 colossal figures of Hindoo divinities, each one the centre of a group; and beyond this main temple may be seen others of smaller size and similar decorations. These gigantic works, which Elphinstone and others compare with the pyramids of Egypt as works of labor, and far surpassing them as specimens of art, are of unknown antiquity, and seem to have been executed by Buddhists as well as by Brahmans. The village of Ellora is small, and is resorted to by numerous pilgrims.

**ELLSWORTH**, a central county of Kansas, intersected by Smoky Hill river; area, 720 sq. m.; pop. in 1870, 1,185. The Kansas Pacific railroad passes through it. The chief productions in 1870 were 2,175 bushels of wheat, 12,167 of Indian corn, 4,393 of potatoes, and 1,604 tons of hay. Capital, Ellsworth.

**ELLSWORTH**, a city and the capital of Hancock co., Maine, the port of entry of the district of Frenchman's Bay, 26 m. S. E. of Bangor, situated on both sides of Union river, a navigable stream, which empties into Frenchman's bay about 4 m. below this point, the opposite banks being connected by several bridges; pop. in 1870, 5,257. It is one of the most flourishing towns of the state, and is extensively engaged in the lumber trade. In 1872 there were registered, enrolled, and licensed 290 vessels, with an aggregate tonnage of 17,-

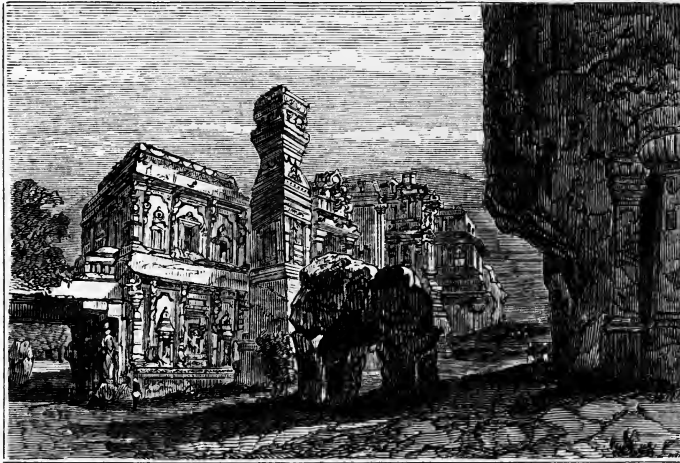

Temple of Kailasa.

crated to Siva, and two to the Trimurti, or Brahmanic trinity. They are all adorned with colossal statues and innumerable sculptures and bass-reliefs. The greatest and most remarkable of these monuments is the *Kailasa*, or paradise, dedicated to Siva, and designed to represent the court of that divinity where he receives those of his worshippers who, having escaped metempsychosis, come after death to enjoy eternal happiness. This does not, like the others, extend subterraneously, but rises to a lofty height in an excavation 401 ft. in depth and 185 in breadth. It is composed of a portico, a chapel, and a grand pagoda. The portico is sustained by pillars and flanked by curious sculptures. Two obelisks, 41 ft. in height, 11 ft. square, beautifully carved, and two gigantic elephants, surround and support the chapel, which is likewise adorned on every side by statuary. The pagoda rises from the centre of the whole structure to the height of 100 ft., and is surrounded externally by mythological

736; engaged in the cod and mackerel fishery, 50 vessels of 1,543 tons. The city contains 11 manufactories of lumber, 2 of planing machines, pails, sash, blinds, &c., 1 of pumps, blocks, &c., 4 of saddles and harness, 2 of carriages and sleighs, 1 of axes, 1 of furniture, 2 of sails, and an iron and brass foundry. There are 4 hotels, a weekly newspaper, a library of 1,000 volumes, 22 school houses with an average of about 800 pupils, and 6 churches.

**ELLSWORTH. I. Oliver**, an American statesman and jurist, born in Windsor, Conn., April 29, 1745, died Nov. 26, 1807. He graduated at the college of New Jersey in 1766, and soon after commenced the practice of law. In 1777 he was chosen a delegate to the continental congress, and he was a member of the council of Connecticut from 1780 to 1784, when he was appointed a judge of the superior court. In 1787 he was elected to the convention which framed the federal constitution, and was afterward a member of the state convention

which ratified that instrument. He was a senator of the United States from 1789 to 1796, when he was nominated by Washington chief justice of the supreme court of the United States, over which he presided with great distinction, his opinions being marked by sound legal and ethical principles, in clear and felicitous language. In 1799 he was appointed by President Adams envoy extraordinary to Paris, and with his associates, Davie and Murray, he successfully negotiated a treaty with the French. This accomplished, and his health beginning to fail, he visited England for the benefit of its mineral waters; but his infirmities increasing, he resigned his office of chief justice in 1800. Returning to Connecticut, he was again elected a member of the council; and in 1807 he was appointed chief justice of the state, which office he declined on account of his health. **II. William Wolcott**, son of the preceding, born in Windsor, Nov. 10, 1791, died in Hartford, Jan. 15, 1868. He graduated at Yale college in 1810, and was admitted to the bar in 1813. From 1829 to 1833 he was a representative in congress; from 1838 to 1842 governor of Connecticut; and from 1847 to 1861 judge of the supreme court of that state.

**ELLWANGEN**, a town of Würtemberg, situated on the Jaxt, 55 m. N. E. of Stuttgart; pop. in 1867, 3,895, of whom about 700 are Protestants. It is the seat of the government of the circle of Jaxt, and has several schools and charitable institutions. The manufactures were formerly insignificant, but are growing in importance. Until 1802 it was the capital of the sovereign Benedictine provost of Ellwangen, who had a territory of about 140 sq. m. and an income of 120,000 florins. Near the town are the castle of Hohen-Ellwangen and a famous pilgrims' church.

**ELLWOOD, Thomas**, an English Quaker minister, a friend of Milton, born in Crowell, Oxfordshire, in 1639, died March 1, 1713. At an early age he attached himself to the society of Friends, thereby giving great offence to his father; but neither blows nor persuasions could induce him to renounce his new sentiments, to take off his hat before his parents, or to address them with other pronouns than "thou" and "thee." He was the author of numerous controversial works, the most considerable of which is his "Sacred History of the Old and New Testaments" (1705-'9). He wrote a poem entitled "Davideis" (1712), of which King David was the hero, and also left "Memoirs of his own Life" (1714). But he is chiefly known from the circumstance that he was one of those selected by the poet Milton to read to him after the loss of his sight. During the raging of the plague in London in 1665 he obtained a retreat for Milton at Chalfont, and there he is said first to have suggested the idea of the "Paradise Regained."

**ELM**, a tree of the natural order *ulmaceæ*, which embraces some of the noblest and most important species in the United States. All

the plants belonging to this family have simple, rough, serrate, unequal-sided leaves; flowers small, in bunches on the side of the twigs; the fruit either a winged samara or a drupe. Three genera of *ulmaceæ* are found within the limits of the United States. The most conspicuous of these is *ulmus*, of which we especially notice the white or American elm (*U. Americana*, Linn.). No tree can surpass this in the beauty of its proportions. In old trees especially, from the wide-spreading, buttress-like roots to the wider spreading branches, the curvature is beautiful and graceful in the extreme. Situation seems, however, to give variety to the outline. In wet pastures or similar moist places, it sends up a tall, slender trunk, crowned with a few pendent limbs, and clothed nearly from the ground with a feathery investment of small branches, which are scarcely more than leafy bunches of twigs, and presents a most graceful and striking appearance. The rapidity of its growth adapts it to arti-

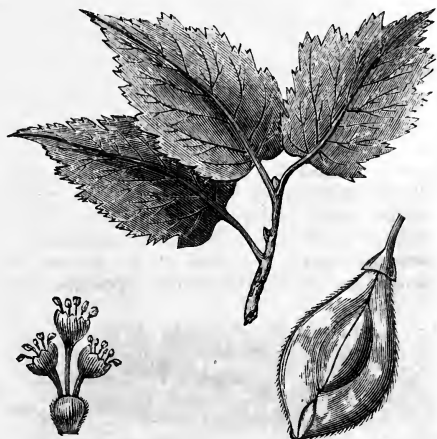

American Elm (*Ulmus Americana*).

ficial planting where shade is soon needed. Hardy to an unusual degree, it is a great favorite with the tree planter, and is found from Hudson bay to Georgia. The wood of the white elm is used for making hubs of wheels, and is preferred for that purpose to any other native wood. Yokes are made of it, and near the coast ship blocks are constructed of its timber. The white elm grows readily from seed, which should be sown as soon as ripe, and may be gathered in almost any desirable quantity from the ground under the trees, falling as early as June. The seeds should be very slightly covered, and the young plants will rise in a few weeks, when they should be watched and weeded, and in succeeding seasons should be thinned out and transplanted to insure well formed trees. In transplanting large and vigorous young specimens found where they have appeared spontaneously, it is necessary to secure as many of the fibrous

roots as possible, and have them spread out in large and ample holes, well prepared with good soil; care must be taken not to have them too deeply covered. The slippery or red elm (*U. fulva*, Mx.) is a much smaller tree, with larger and more beautiful foliage, and



Slippery Elm (*Ulmus fulva*).

soft, downy, rusty-haired buds, whence the name sometimes applied of red elm. Its flowers are in lateral clusters; the samara is larger and with a broader border. The inner bark contains a great quantity of mucilage, of much value in medicine. Michaux considers its wood as superior to that of the white elm. The tree can be readily grafted upon the white



American Elm (*Ulmus americana*).

elm, and if only for ornament it is well worthy of cultivation. The corky white elm (*U. racemosa*, Thomas) has its branches often beset with corky ridges; its leaves are similar to those of the white elm; its flowers are in racemes; its wood is tougher and finer grained.

The wahoo or winged elm (*U. alata*, Mx.) is a small tree, seldom exceeding 30 feet in height, has a fine-grained, valuable wood, and is to be found in Virginia and southward. The English elm (*U. campestris*, Linn.) was early introduced into this country, and is a



English Elm (*Ulmus campestris*).

stately tree, contrasting finely with the American. Its branches, unlike that, tend upward, or else spread more horizontally, and its foliage is of a darker green and more pleasing to the eye. The wych elm (*U. montana*, Bauhin) has been partially introduced; it is much cultivated in Scotland, and goes by the name of the Scotch elm. It resembles the slippery



Wych Elm (*Ulmus montana*).

elm.—The nettle tree (*Celtis occidentalis*, Linn.) has a trunk from 20 to 60 ft. high. Its leaves are obliquely lanceolate, acuminate, sharply serrate; its fruit is a sort of plum or drupe of a yellowish green color. It has several varieties, considered by some botanists as distinct species, but probably nothing more

than forms of the above. They grow on the poorest and most arid soils, but flourish best in a rich and moist ground. Michaux says that the wood of the hackberry (*C. crassifolia*, Mx.) is fine-grained and compact, but not heavy. The planer tree (*planera aquatica*, Gmelin) has small leaves like those of elms; the flowers are borne in small axillary clusters; the fruit is nut-like. According to Michaux, it grows on wet banks in Kentucky and southward. He considers its wood as hard, strong, and proper for various purposes. It has not, however, been put to any use in this country, and is so little esteemed as to have received no popular name. It is worthy of attempts at cultivation northward, and can be readily propagated by grafting it upon the elm.

**ELMACINUS, Elmacin, or Almakin, George** (known in the East by the name of Ibn Amid), an Arabian historian, born in Egypt in 1223, died in Damascus in 1273. He was a Christian, and held at the court of the sultans of Cairo the office of *ketib* or secretary. He wrote a history of the East, especially of the Arabs, from the creation of the world to the time of the crusades, a portion of which was published both in Arabic and Latin by Erpenius, at Leyden, in 1625; the Latin version was soon reprinted, and was followed by a French translation. A complete edition in Arabic remains in use among the Christians of the Levant.

**ELMES, James**, an English architect, born in London, Oct. 15, 1782, died in 1862. He gained the silver medal in architecture at the royal academy in 1804, and was for some time surveyor and civil engineer of the port of London; but loss of sight (which, however, he afterward partially recovered) caused him to relinquish the office in 1828. He published "Sir Christopher Wren and his Times" (4to, 1823); "Lectures on Architecture" (8vo, 1823); "General and Bibliographical Dictionary of the Fine Arts" (8vo, 1826); "On the Law of Dilapidations" (royal 8vo, 1826); "Treatise on Architectural Jurisprudence" (8vo, 1827); "Survey of the Harbor and Port of London" (1838); "Horæ Vacivæ" (1851); and "Thomas Clarkson, a Monograph" (1854).

**ELMINA, or St. George da Mina**, a British settlement on the Gold coast, Ashantee, Africa, at the mouth of the river Beyah, about 6 m. W. of Cape Coast Castle; lat. 5° 5' N., lon. 1° 20' W.; pop. about 15,000. The native town is large, irregular, and very dirty. The inhabitants are chiefly fishermen, traders and their servants, and slaves employed as mechanics; but there are a few mulattoes who are wealthy. In the neighborhood are some handsome country residences and cultivated farms. The surrounding country is undulating and thickly wooded. The town is defended by a castle built on a low rocky peninsula extending from the E. bank of the river. The point is surrounded by a bed of rocks, on which the sea breaks with great violence. The castle, the oldest European settlement on the Guinea coast, was begun by the

Portuguese about 1481, and was 80 years in building; it is secure against an attack from any native force. There is another large defensive work, the fort of St. Jago, which commands the castle; but its climate is reputed to be fatal to Europeans.—Elmina was captured by the Dutch in 1637, and was ceded to them by Portugal in 1641. In 1872 it was transferred together with the other Dutch settlements on the coast to Great Britain. This transfer resulted in a war with the Ashantees in 1873; and on June 13 the native king's quarter of Elmina was bombarded and burned by the British, because the inhabitants had supplied the Ashantees with munitions of war.

**ELMIRA**, a city and the capital of Chemung co., New York, situated on both sides of the Chemung river, near the mouth of Newtown creek, about 160 m. W. S. W. of Albany, and 175 m. W. N. W. of New York; pop. in 1870, 15,863, of whom 3,391 were foreigners. It is handsomely laid out, in a broad and fertile valley. The Chemung canal connects it with Seneca lake, the Junction canal with central Pennsylvania, and the Erie and Northern Central railroads with New York, Philadelphia, &c. Newtown creek furnishes abundant water power. There are rolling mills and other iron works, flour mills, breweries, tanneries, and manufactories of boots and shoes, edge tools, agricultural implements, carriages, &c. The Elmira iron and steel works manufacture large quantities of rails, besides about 16,000 tons of locomotive and bridge iron annually. The railroad companies have extensive car shops here. There are four banks, a savings institution, 300 stores, a large number of warehouses, and several hotels. The city is governed by a mayor and a board of 12 aldermen, two from each ward. The fire department is under the charge of a chief engineer and two assistants. There are 31 public schools, including a high and a normal school, which in 1872 had 56 teachers and an average attendance of 2,295 pupils; total expenditure for school purposes, \$64,348, of which \$31,037 were for teachers' wages. The Elmira female college (Presbyterian), organized in 1855, had in 1872 12 professors and instructors, 123 students, a library of 3,000 volumes, and an endowment of \$100,000. The Elmira free academy had 5 instructors and 128 pupils. There are two daily and two weekly newspapers, a quarterly periodical, a young men's Christian association, and 20 churches.—Elmira was settled about 1790. It was incorporated as a village under the name of Newtown in 1815, and received its present name in 1828. In 1864 a city charter was granted. Its use by the government during the civil war as a rendezvous for Union troops and as a depot for confederate prisoners materially aided its prosperity.

**ELMORE**, a S. E. county of Alabama, bounded E. and S. by the Tallapoosa river and intersected by the Coosa; area, about 550 sq. m.;

pop. in 1870, 14,477, of whom 6,730 were colored. The South and North Alabama railroad passes through the S. W. part. The surface is undulating and the soil fertile. The chief productions in 1870 were 10,330 bushels of wheat, 198,371 of Indian corn, 18,078 of oats, 32,560 of sweet potatoes, 5,697 of peas and beans, and 7,295 bales of cotton. There were 944 horses, 1,411 mules and asses, 2,706 milch cows, 3,812 other cattle, and 8,286 swine; 9 manufactories of carriages and wagons, 1 of cotton goods, and 2 saw mills. Capital, Wetumpka.

**ELMSLEY, Peter**, an English scholar, born in 1773, died March 8, 1825. He was educated at Westminster school, and at Merton college, Oxford. He officiated for a time in a small chapelry in Little Horkesley, Essex; but becoming master of a fortune by the death of an uncle, he devoted himself to literary studies, and particularly to Greek literature. He lived for a while in Edinburgh, where he was intimately associated with the founders of the "Edinburgh Review," and contributed to that periodical several articles, among which were reviews of Heyne's "Homer," Schweighäuser's "Athenæus," Blomfield's "Prometheus," and Porson's "Hecuba." In 1816 he made a voyage to Italy in search of manuscripts, and passed the winter of 1818 in researches in the Laurentian library at Florence. The next year he was appointed to assist Sir Humphry Davy in trying to decipher some of the papyri found at Herculanum. After his return to England he became principal of St. Alban's hall, Oxford, and Camden professor of modern history in the university. From 1809 to 1823 he published editions of several of the Greek tragedies.

**ELOCUTION.** See ORATORY, and VOICE.

**ELOHIM**, one of the Hebrew names of the Deity, the plural of *Eloah*. The name is also applied to angels, princes, judges, great men, and even to false gods.

**EL PASO.** I. The extreme W. county of Texas, bounded N. by New Mexico, touched on the N. E. by the Rio Pecos, and separated on the S. W. from Mexico by the Rio Grande; area, 9,450 sq. m.; pop. in 1870, 3,671, of whom 306 were colored. More than nine tenths of the area consists of sandy plains without timber or water. Salt lakes are found in the N. part. It is crossed by several mountain ranges. The only cultivated portion is the narrow valley of the Rio Grande, which is productive when irrigated. Capital, Franklin.

II. A central county of Colorado, bordering on the Rocky mountains, and containing Pike's peak; area, about 2,500 sq. m.; pop. in 1870, 987. The surface is diversified. It is traversed by the Fontaine qui Bout, the valley of which is fertile. The chief productions in 1870 were 11,455 bushels of Indian corn, 11,727 of oats, 8,876 of wheat, 760 tons of hay, and 16,900 lbs. of wool. There were 10,800 sheep; 2 flour mills, and 4 saw mills. Capital, Colorado City.

**EL PASO**, or **El Paso del Norte**, an inland town of Mexico, in the N. E. angle of the state of

Chihuahua, on the Rio Grande, near the frontier of New Mexico, 945 m. N. W. of the city of Mexico; lat. 31° 45' N., lon. 106° 28' W.; pop. about 6,000, chiefly mestizoes, with many Indians of pure blood. This place was first established as a military post to check the inroads of the savage tribes which then, as now, ravaged the whole north of the republic. It forms a separate town, though the name is often extended to a series of minor settlements reaching some 15 m. along the banks of the Rio Grande. The fort has been transferred to El Paso del Rio Grande, on the road from Chihuahua to Santa Fé. The country surrounding El Paso consists of well cultivated fields of maize, wheat, and other cereals, dotted with gardens and orchards yielding a luxuriant supply of all the delicate fruits of the temperate zone. The best wine in the republic is made here; and also a species of brandy, called by the border Americans Paso whiskey. The inhabitants, though generally rich, pay little attention to material comfort.

**ELPHINSTON, James**, a Scottish grammarian, born in Edinburgh in 1721, died at Hammersmith, near London, Oct. 8, 1809. He studied at the university of Edinburgh, became tutor to Lord Blantyre, superintended an edition of the "Rambler" in his native town, and in 1751 opened a school at Kensington. He was a zealous advocate of a change in English orthography, and published several works on the subject which exposed him to great ridicule. A translation of Martial (4to, 1782) was no better received. His principal works are: "French and English Languages" (2 vols. 12mo, 1756); "Education, a Poem" (1763); "English Language" (2 vols. 12mo, 1765); "Propriety ascertained in her Picture" (1786); *Poeta Sententiosi, Latini*, &c. (1794); and "Fifty Years' Correspondence, English, French, and Latin, in Prose and Verse, between Geniusses ov boath Sexes and James Elphinston" (8 vols. 12mo, 1794).

**ELPHINSTONE, George.** See KEITH.

**ELPHINSTONE, Mountstuart**, an English statesman and historian, 4th son of John, 11th Baron Ephinstone, born in 1779, died Nov. 20, 1859. In 1795 he entered the service of the East India company; in 1808 was ambassador to the Afghan court at Cabool; from 1810 to 1817 was resident at the court of Poonah, and was commissioner to that province from 1817 to 1819, when he was appointed governor of Bombay. He resigned in November, 1827. He was the author of an "Account of the Kingdom of Cabul and its Dependencies in Persia, Tartary, and India" (4to, London, 1815), which has been twice reprinted; and "History of India: the Hindoo and Mahometan Periods" (2 vols. 8vo, 1841; 3d ed., 1848).

**ELSNORE**, or **Elsineur** (Dan. *Helsingör*), a maritime town of Denmark, in the bæiljwick of Frederiksborg, island of Seeland, 23 m. N. E. of Copenhagen; lat. 56° 2' N., lon. 12° 38' E.; pop. in 1870, 8,891. It is built on

the narrowest part of the Sound, here but 3½ m. in width, opposite the Swedish town of Helsingborg. It commands the principal passage between the Cattagat and the Baltic, and is the spot where the Sound dues (abolished in 1857) were formerly paid by all foreign vessels, except those of Sweden, navigating that channel. The town is substantially but irregularly built on ground rising gradually from the shore. The harbor is very small, but has a depth of 18 ft. The roadstead is excellent, and is generally crowded with vessels, and there is a large foreign commerce. Adjacent to the harbor, on the N. E., on a tongue of land running out into the sea, is the castle of Kronborg, built by Frederick II. about 1580. Modern fortifications have since added to its strength. It is now chiefly used as a prison. Caroline Matilda, queen of Christian VII., was imprisoned here until the interference of her brother, George III. of England. Under the

the Swedes, under the orders of Wrangel, but was restored to the Danes in 1660. It failed to prevent the passage of the British fleet under Sir Hyde Parker, with Nelson as his second in command, in 1802.

**ELSSLER, Fanny and Therese**, two sisters celebrated as dancers, born in Vienna, Therese in 1808, Fanny in 1811. Fanny, the more famous, was instructed in the juvenile ballet corps of the Viennese theatre, and at the age of six made her appearance on the stage. Subsequently she received instructions from Aumer, and a marked influence upon her general æsthetic culture was exercised by Baron Friedrich von Gentz. The two sisters went to Naples in 1827, and in 1830 made their first appearance at Berlin. Subsequently they went to Vienna and other cities, and on Sept. 19, 1834, they made their first appearance in Paris, in *La tempête*, a ballet adapted from Shakespeare's "Tempest" by Adolphe Nourrit. Fanny was

ranked with Taglioni, then at the head of her profession in Paris, and she soon eclipsed her celebrated rival in the Spanish *cachucha*. In 1841 the sisters visited the United States, where they met with brilliant success, and afterward went to Russia. In 1851 Fanny retired from the stage with a large fortune, and purchased a villa near Hamburg. Her sister contracted in April, 1850, a morgantic marriage with Prince Adalbert of Prussia (who died in 1873), and was ennobled under the title of Frau von Barnim.

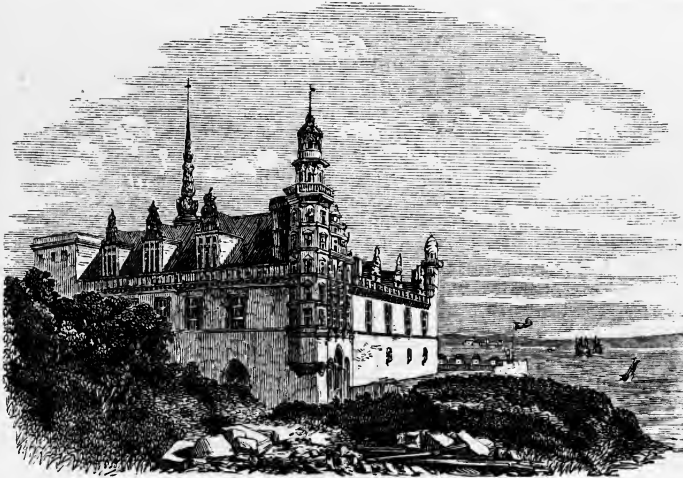

Kronborg Castle.

castle are casemates capable of holding 1,000 men. According to a popular tradition, Holger Danske, the legendary hero of Denmark, resides in one of the subterranean vaults. In the courtyard of the castle is the lighthouse, showing a fixed light 113 ft. above the sea. A short distance N. W. of the town is the palace of Marienlyst (Mary's delight), once a royal residence, but now in private occupation. Near by is shown a pile of rocks, erroneously called the tomb of Hamlet, of whose story, as told by Shakespeare, Elsinore is the scene. Local industry is mostly engaged in the refining of sugar and brandy, printing cottons, fishing, &c.; and there is an extensive manufactory of arms at Hammerwolle in the suburbs. —Elsinore was erected into a city in 1425; was taken and burned by the forces of Lübeck in 1522, and was retaken in 1535 by Christian II. It was enlarged by Dutch colonists in 1576. The castle was taken Sept. 6, 1658, by

**ELTON**, a salt lake in the government of Saratov, Russia, 70 m. E. of the Volga, and 130 sq. m. in extent. It yields annually upward of 100,000 tons of salt, the collection of which gives employment to 10,000 persons. In the hottest season the crystallized salt along its banks and on its surface gives it the appearance of a vast sheet of ice or frozen snow. It is nowhere more than 15 inches deep.

**ELVAS**, a fortified frontier city of Portugal, in the province of Alemtejo, 105 m. E. of Lisbon, and 10 m. W. of Badajoz, Spain, on a hill near the bank of the Guadiana; pop. about 10,000. It became a city in 1513, and was created a bishopric by Pius V. in 1570. It is an important stronghold, having an arsenal, and spacious bomb-proof barracks for 7,000 men. The fort of Lippe on a neighboring hill is considered impregnable. The town itself is poorly built, and many of the venerable Moorish buildings which line its streets are crumbling to



pieces. It has a cathedral, college, seminary, theatre, several churches and convents, and manufactories of arms and jewelry. It is supplied with water from a distance of three miles, by means of a fine Moorish aqueduct. During the peninsular war it was a place of great importance; and in March, 1808, it was taken by the French under Junot, and held till the convention of Cintra in August, 1808.

**ELWES, John**, an English miser, born in Southwark about 1714, died Nov. 26, 1789. His own family name was Meggot, but he exchanged it for that of his uncle, Sir Harvey Elwes, from whom he received a large inheritance. At an early period of his life he attended Westminster school, and became a good classical scholar. He was sent to Geneva to complete his education, and there distinguished himself as one of the boldest riders in Europe. After returning to England he indulged in

gambling, frequenting the most noted gaming houses. He next took to hunting, and his stable of fox hounds was considered the best in the kingdom; yet he kept but a single servant to attend to all his cows, dogs, and horses. From his parsimonious mode of life his fortune rapidly increased, and when worth half a million he refused to accept a seat in parliament unless on the express stipulation that he should be brought in for nothing, and was elected for Berkshire in 1774. His miserly habits increased with his fortune, and during the latter years of his life he abandoned gaming, hunting, and every comfort, and died the possessor of £800,000, after having suffered greatly from fear of poverty.

**ELY**, a city of Cambridgeshire, England, on an eminence near the Ouse, 16 m. N. N. E. of Cambridge; pop. about 8,000. It consists principally of one street, and contains many old

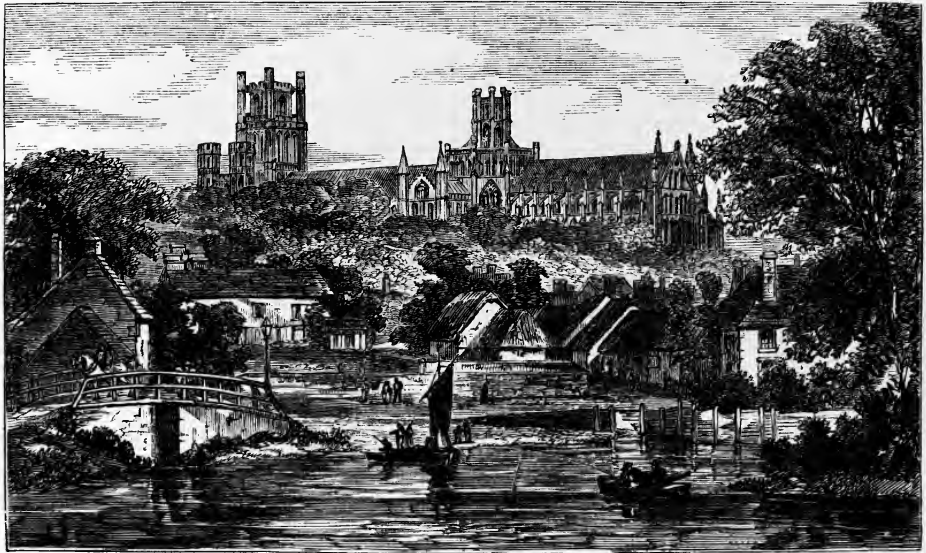

Ely Cathedral.

buildings. It is the seat of a bishopric which was founded in 1107. Its cathedral is a splendid structure, built in successive centuries from 1174 to 1534, and presenting a singular mixture of the Saxon, Norman, and early English styles. The churches of St. Mary and of the Holy Trinity are also remarkable both for their age and splendor. A famous convent was founded here about 670 by Ethelreda, wife of Egfrid, king of Northumberland, and she became its first abbess. It was destroyed by the Danes in 870, and 100 years later was rebuilt by Ethelwold, bishop of Winchester, who placed in it monks instead of nuns. Ely has manufactories of earthenware and tobacco pipes, breweries, flax and hemp-seed oil mills, lime kilns, extensive gardens in its vicinity, the produce of which is sent to the London and Cambridge

markets, and several benevolent institutions and schools, among which is a grammar school founded by Henry VIII. It is the capital of a division of Cambridgeshire called the "Isle of Ely," separated from the rest of the county by the Ouse. This district is included in the reclaimed marsh known as Bedford Level.

**ELYMAIS**, a province of ancient Elam, between the river Eulæus and the Persian gulf. The notices of it in classical writers are very confused; but it was more probably a district of Elam than an independent territory S. of it, or merely a town. The books of Maccabees and Tobias name it as a city of Persia, to which Antiochus Epiphanes laid siege; but not one of the ancient writers who speak of this expedition mentions the place. Elymais is often used as equivalent to Elam. (See **ELAM**.)

**ELYSIUM**, or **Elysian Fields**, among the Greeks and Romans, the dwelling place of the blessed after death. While the oriental and most other peoples sought this abode in the upper regions of the sky, the Greeks placed it in the west, on the ends of or beneath the earth, where the sun goes down. According to Homer, Elysium was a plain on the ends of the earth, where men live without toil or care, where there is neither snow nor winter storms nor rains; where the lovely and cooling zephyrs blow unceasingly with light murmur; and where dwelt Rhadamanthus, who, in the upper world, was the justest of men. The position of Elysium changed with the progress in geographical knowledge, proceeding further and further to the west. Hesiod speaks of the happy isles of the ocean, and other writers supposed it to be somewhere in the Atlantic, till Pindar and the later poets put it beneath the earth. According to the later description, the meads of Elysium three times in a year brought forth the most beautiful flowers. The inhabitants enjoyed the reward for their virtues on earth, and whoever had three times resisted a temptation to do evil attained to this abode. A never-setting sun shone upon them, and melancholy was removed far away. The air, fragrant and tinted with purple, breathed softly from the sea, the flowers were twined into wreaths for the dwellers, peaceful waveless rivers flowed by, and horse races, games, music, and conversation occupied the hours. According to Homer, Rhadamanthus alone ruled Elysium, being admitted there as the representative of justice. Hesiod knows Elysium as the Isles of the Blessed, where Cronos rules, and Titans and heroes dwell.

**ELZEVIR**, **Elsevier**, or **Elzevler**, the name of a family of Dutch printers, established at Leyden, Amsterdam, the Hague, and Utrecht, in the 16th and 17th centuries, and who for nearly 100 consecutive years were distinguished for the number and elegance of their publications, especially their editions of ancient authors.—Louis, the founder of the family, born in Louvain in 1540, emigrated to Holland in 1580, in consequence of the religious troubles which agitated his native city, and settled in Leyden, where he died, Feb. 4, 1617. He became a petty officer of the university of Leyden, and also engaged in the business of a bookseller and printer. In the latter capacity he is said to have produced, between 1583 (when the *Drusii Ebraicarum Questionum ac Responsionum libri duo*, the first book bearing the imprint of Elzevir, appeared) and his death, 150 works. He is said to have been the first printer who observed the distinction between the vowels *i* and *u* and the corresponding consonants *j* and *v*. Of the seven sons of Louis, five followed the business of their father, viz.: MATTHEUS, who was established at Leyden, where upon his death in 1640 he was succeeded by his sons Abraham and Bonaventure, who became partners in Leyden; LOUIS (II.), who

in 1590 established a printing house at the Hague, and died there in 1621; GILLES, who was in business at the Hague and subsequently in Leyden; JOOST, who settled in Utrecht; and BONAVENTURE, who was born in 1583 and died about 1652. Bonaventure in 1626 associated himself with ABRAHAM, the son of Mattheus, and from their press issued those numerous exquisite editions of the classics, as also those on history and politics (62 vols. 16mo), called by the French *Les petites républiques*, with which the name of Elzevir is now most familiarly associated. The Livy and Tacitus of 1634, the Pliny of 1635, the Virgil of 1636, and the Cicero of 1642, are among the best of their productions. Abraham died Aug. 14, 1652. Their children carried on the business for some time under the name of their parents. LOUIS (III.), son of Louis (II.), founded the Elzevir printing establishment at Amsterdam in 1638, and entered into a partnership with his cousin Daniel in 1654, which lasted 10 years. He was born in 1617, and died in 1670, at which time the reputation of the Elzevirs had reached its highest point. Among their chief publications are the celebrated New Testament of 1658, a series of Latin classics, the *Etymologicon Linguae Latinae*, and an edition of the *Corpus Juris*. Between 1664 and 1680 Daniel carried on the business alone, and in that period published 152 works. He was the last of his family who excelled in printing, although his widow and Pieter, grandson of Joost, carried on the business for some years.—The merit of the Elzevirs consisted less in their learning or critical abilities, in which they were inferior to the Aldi, the Stephenses, and others of the celebrated printers of the 15th, 16th, and 17th centuries, than in the clearness and beauty of their type, the excellent quality of their paper, which was made in Angoulême, and the general elegance of their publications. The texts of their editions of the classics were generally reprints, and were sometimes pirated from other sources. All their choice works, particularly the small editions of the classics, bring large prices at the present day; and the name Elzevir applied to a book has become a synonyme for typographical correctness and elegance. The Elzevirs printed several catalogues of their works, but the best account of them is to be found in the *Notice de la collection d'auteurs latins, français et italiens, imprimée de format petit en 12mo par les Elzevir*, in Brunet's *Manuel du libraire* (Paris, 1820), and in Bérard's *Essai bibliographique sur les éditions des Elzevirs* (Paris, 1822). See also Pieter's *Annales de l'imprimerie elzévirienne* (Ghent, 1851-'2), in which the number of works printed by the Elzevirs is stated at 1,213, of which 968 were in Latin, 44 in Greek, 126 in French, 32 in Flemish, 22 in oriental languages, 11 in German, and 10 in Italian. Their imprint was: *Apud Elzevirios, or Ex Officina Elzeviriorum or Elzeviriana*; and frequently the title page of their books contains a device of a blazing wood

pile, emblematic of their name, compounded of *els*, alder, and *vuur*, fire.

**EMANUEL**, an E. county of Georgia, bounded N. by the Ogeechee river, and S. W. by Pendleton's creek; area, about 1,000 sq. m.; pop. in 1870, 6,134, of whom 1,703 were colored. The principal streams which intersect it are the Great Ohoopee and the Cannouchee. It has a level surface, and a sandy, unproductive soil. Timber is abundant. The chief productions in 1870 were 103,705 bushels of Indian corn, 21,399 of oats, 24,353 of sweet potatoes, and 1,376 bales of cotton. There were 1,094 horses, 4,013 milch cows, 11,167 other cattle, 14,988 sheep, and 15,464 swine; 4 saw mills and 1 cotton factory. Capital, Swainsborough.

**EMANUEL** (Port. MANOEL) I., king of Portugal, called the Great, and the Happy, born May 3, 1469, ascended the throne upon the death of John II., in 1495, and died in Lisbon, Dec. 13, 1521. He was the son of Duke Ferdinand of Viséu, grandson of King Edward of Portugal, nephew of Alfonso V., and cousin of John II. His father, accused of conspiracy against John II., was slain by the latter with his own hand. Emanuel, bearing the title of duke of Beja, was educated in Spain, where in 1497 he married Isabella, daughter of Ferdinand and Isabella, and heiress to the crown of Castile. She died in 1498, and Emanuel married Donna Maria, her sister, two years later. He received the kingdom in a state of prosperity, and by his activity and sagacity raised Portugal to her most brilliant point of power and glory. He signalized the beginning of his reign by pursuing with an ardor surpassing that of all his predecessors the long-sought passage by sea to India. Mainly under his patronage were made the voyages of Vasco da Gama, Albuquerque, and Pedro Alvarez de Cabral; in his reign Goa became a Portuguese settlement, and Brazil, the Moluccas, &c., were discovered; the commerce of the Indies was opened to Portugal, wealth accumulated, and a spirit of enterprise took possession of the nation, which could now boast of a brilliant succession of navigators and generals. Less successful were his efforts for conquest in Morocco, where dearly purchased victories secured no lasting gain. He devoted himself to the Roman Catholic church, sent missionaries with all his fleets to convert whatsoever people they might discover, and sought to reform the character of the Portuguese ecclesiastics. He banished the Jews and Moors, and introduced the inquisition. He ruled 20 years without convening the cortes, published a code of laws, and succeeded in remaining at peace with all Europe. He was a patron of men of letters, and himself the author of memoirs of the Indies. His second wife, Maria, died in 1517, and in 1519 he married Eleonora of Austria, sister of Charles V.

**EMBALMING**, the process of preserving animal bodies from corruption by introducing antiseptic substances into the spaces left vacant by the

removal of the internal parts. The art was extensively practised by the ancient Egyptians, and the mummies found at this day in their sepulchres, where they have lain for 3,000 years or more, testify to the perfection it had reached in those remote periods. Reptiles and other animals were held sacred and worthy of embalming; therefore when, in addition to the countless bodies of human beings still to be found in the places where they were deposited, are reckoned the millions of dogs, apes, crocodiles, cats, ibises, bulls, rams, foxes, asps, and other animals, of more than 50 species in all, it is a matter of wonder whence were obtained all the resins, drugs, and spices which are described as essential to the process. After Egypt became a Roman province the art continued to be practised, and was adopted to some extent by the Romans themselves. Among other races also the same practice has in former times prevailed, or at least a modification of it designed to produce a similar result; such, for example, as drying the bodies of the dead. This was probably the custom of the Guanches, the former inhabitants of the Canary islands. In the great temple of the sun at Cuzco bodies of the incas and of their queens have been found, clothed in their former princely attire, seated upon chairs of gold, their heads inclined downward, covered with raven-black or silver-gray hair, and their hands placidly crossed over their bosoms. Exposure of the bodies to the exceedingly dry and cold air of the mountainous region, it was thought by Garcilaso, was sufficient to preserve these bodies without recourse to the artificial processes adopted by the Egyptians. These have been particularly described by Herodotus and Diodorus Siculus, and the accounts of the former especially have been regarded by most authorities as presenting an exact exposition of them. Some, however, question the adequacy of the processes thus given to account for the results, and state that modern experimenters fail entirely of success in endeavoring to perform the operation by their instructions. The account given by Herodotus (ii. 86) is as follows: "There are a set of men in Egypt who practise the art of embalming, and make it their proper business. These persons, when a body is brought to them, show the bearers various models of corpses made in wood, and painted so as to resemble nature. The most perfect is said to be after the manner of him [Osiris] whom I do not think it religious to name in connection with such a matter; the second sort is inferior to the first, and less costly; the third is the cheapest of all. All this the embalmers explain, and then ask in which way it is wished that the corpse should be prepared. The bearers tell them, and having concluded their bargain, take their departure, while the embalmers, left to themselves, proceed to their task. The mode of embalming, according to the most perfect process, is the following: They take first a crooked piece of iron and with it draw out the brain through the nostrils, thus

getting rid of a portion, while the skull is cleared of the rest by rinsing with drugs; next they make a cut along the flank with a sharp Ethiopian stone, and take out the whole contents of the abdomen, which they then cleanse, washing it thoroughly with palm wine, and again frequently with an infusion of pounded aromatics. After this they fill the cavity with the purest bruised myrrh, with cassia, and every other sort of spicery except frankincense, and sew up the opening. Then the body is placed in natron for 70 days, and covered entirely over. After the expiration of that space of time, which must not be exceeded, the body is washed, and wrapped round from head to foot with bandages of fine linen cloth, smeared over with gum, which is used generally by the Egyptians in the place of glue, and in this state it is given back to the relatives, who enclose it in a wooden case which they have had made for the purpose, shaped into the figure of a man. Then fastening the case, they place it in a sepulchral chamber, upright against the wall. Such is the most costly way of embalming the dead. If persons wish to avoid expense and choose the second process, the following is the method pursued: Syringes are filled with oil made from the cedar tree, which is then, without any incision or dis-embowelling, injected into the abdomen. The passage by which it might be likely to return is stopped, and the body laid in natron the prescribed number of days. At the end of the time the cedar oil is allowed to make its escape; and such is its power that it brings with it the whole stomach and intestines in a liquid state. The natron meanwhile has dissolved the flesh, and so nothing is left of the dead body but the skin and the bones. It is returned in this condition to the relatives, without any further trouble being bestowed upon it. The third method of embalming, which is practised in the case of the poorer classes, is to clean out the intestines with a clyster, and let the body lie in natron 70 days, after which it is at once given to those who come to fetch it away." Diodorus, whose account is similar, also says: "First, one who is termed a scribe marks upon the left side of the body, as it lies on the ground, the extent of the incision which is to be made; then another, who is the dissector, cuts open as much of the flesh as the law permits with an Ethiopian stone, and immediately runs away, pursued by those who are present, throwing stones at him amidst bitter execrations, as if to cast upon him all the odium of this necessary act." Sir Gardner Wilkinson, in his "Popular Account of the Ancient Egyptians," says: "The embalmers were probably members of the medical profession, as well as of the class of priests. Joseph is said to have commanded the physicians to embalm his father, and Pliny states that during the process certain examinations took place which enabled them to study the disease of which the deceased had died. They appear to have been made in compliance with an order

from the government, as he says the kings of Egypt had their bodies opened after death to ascertain the nature of their diseases, by which means alone the remedy for phthical complaints was discovered." Dr. Cormack of London, who has investigated the subject, is of opinion that the essential part of the process was the application of heat to the bodies, which were filled with some form of bitumen. By this means creosote was generated and diffused throughout all tissues of the body, and this method was never divulged, while the other operations may have been practised the better to conceal this as well as to add dignity and mystery to the art. The substances found in mummies are altogether of a resinous nature, and the tissue is impregnated with resinous matter; but this and the wine said to be employed could not preserve the animal substance. All parts, and the linen used for enveloping the body in folds sometimes of 1,000 yards, bear the mark of heat; the bandages are commonly reduced almost to tinder. The object of the gum with which they were smeared may have been to produce creosote by the calcination to which they were subjected. Bitumen also appears to have been employed in a liquid state for filling the cavities of the bodies, though no mention is made of heat being applied to decompose it. The cost of the most expensive method of embalming was a talent of silver.—Thénard's "Chemistry" contains a description of a method employed in recent times by Dr. Chaussier. The body, thoroughly emptied and washed in water, is kept constantly saturated with corrosive sublimate. The salt gradually combines with the flesh, gives it firmness, and renders it imputrescible and incapable of being injured by insects and worms. The author states that he had seen a head thus prepared, which for several years had been exposed to the alternations of sun and rain without having suffered the slightest change. It was very little deformed, and easily recognized, although the flesh had become as hard as wood. A process has been introduced into France by J. N. Gannal of injecting a concentrated solution of sulphate of alumina into the veins of the body, which is employed for anatomical preparations as well as for embalming. Dr. Ure states that a solution of chloride of mercury and wood vinegar is most efficacious for similar uses. He is also of opinion, from the statements of Pliny, that wood vinegar, the antiseptic virtue of which is in the creosote it contains, was the essential means employed by the ancient Egyptians in preparing their mummies, and that the odoriferous resins were of inferior consequence. M. Falconi, in a paper read to the French academy some years ago, stated that after a series of experiments made with different salts, he found that sulphate of zinc, prepared of different degrees of strength, was the best material which he had used. An injection of about a gallon would perfectly well preserve a dead body, as

is proved by the preparations belonging to the anatomical cabinet at Genoa. Bodies so prepared preserve all their flexibility for 40 days. It is only after that period that they begin to dry up, still preserving, however, their natural color. The process employed by Brunetti consists of: 1, washing the circulatory system with water by means of injections; 2, injecting with strong alcohol to remove water; 3, injecting with ether to remove fat; 4, injecting with a strong solution of tannin; 5, submitting the body to a current of warm air, dried by passing over chloride of calcium, a sufficient length of time to abstract all moisture. Removal of viscera and filling cavities with undecomposable and antiseptic material will, of course, render the operation more perfect than when these precautions are not taken. During the late civil war in the United States a process of partial embalming was extensively practised, which, when well performed, often preserved dead bodies for a considerable time. It consisted principally in injecting a strong solution of creosote or of carbolic acid into the veins and arteries, and sometimes removing the contents of the abdominal viscera. A strong solution of alum and sugar of lead was also used, and sometimes chloride or sulphate of zinc. Since then carbolic acid and camphor, dissolved in petroleum and colored with vermilion, have been used, it is said, successfully.

**EMBARGO** (Sp. *embargar*, to arrest), a public prohibition forbidding ships to sail, which may be issued at the outbreak of a war for the purpose of making lawful prizes of hostile ships in port; or, when an important expedition is contemplated, to detain all private vessels, domestic as well as foreign, to secure secrecy; or an embargo may be laid on ships belonging to subjects or citizens with a view to their use as transports or for other government service. In 1794 the American congress laid an embargo for 60 days upon all vessels in the ports of the republic. This was said by the opponents of the measure to be done to obstruct the supply of provisions to the British forces in the West Indies, then engaged in hostilities against the French republic. The embargo most famous in American history is that intended to countervail Napoleon's Berlin and Milan decrees and the British orders in council. On Dec. 22, 1807, on the recommendation of President Jefferson, a law was enacted by congress prohibiting the departure from the ports of the United States of all but foreign armed vessels with public commissions, or foreign merchant ships in ballast, or with such cargo only as they might have on board when notified of the act. All American vessels engaged in the coasting trade were required to give heavy bonds to land their cargoes in the United States. This embargo was repealed by an act passed Feb. 27, 1809, and taking effect March 15, 1809, except so far as related to France and Great Britain and their dependencies; and in regard to them also it was to take

effect after the conclusion of the next succeeding session of congress. A third embargo, laid April 4, 1812, was superseded by the declaration of war against England, June 18, 1812. A fourth embargo was laid by act of Dec. 19, 1813, and repealed four months afterward, prohibiting all exports whatever, and even stopping the coasting trade; fishermen were required to give bonds not to violate the act.

**EMBER DAYS**, certain days in each of the four seasons set apart by the church for fasting, prayer, and the conferring of holy orders. They are the Wednesday, Friday, and Saturday immediately following the first Sunday in Lent, the feast of Pentecost, the 14th of September, and the 13th of December. The weeks in which these fasts occur are called ember weeks. The name is probably derived from the Saxon *ymbren*, a circuit, *i. e.*, the circular days. Among the English Catholics the term "quarter tenses" is still applied to these quarterly fasts. The French call them *jeûne des quatre temps*, and the Roman ritual *jejunia quatuor temporum*. Some writers have supposed the name to be taken from the ancient custom of using ashes or embers in connection with fasting. The custom of fasting on these days is traced back as far as the 3d century; and a decree of the council of Piacenza, in 1095, fixed the time for them as now observed.

**EMBEZZLEMENT**, the wrongful appropriation of the goods of another by a clerk, servant, or other person intrusted therewith; differing in this particular from larceny, where the taking as well as the appropriation is felonious. It was not an indictable offence at common law, and the owner of the property embezzled had no other remedy but a civil action for damages, or in some cases for the recovery of the property itself. Thus if a man hired a horse and fraudulently sold him, if the sale was made in the usual course, *i. e.*, in market overt, and there was nothing to put the purchaser upon his guard, the sale was valid, and the owner could only recover damages against the man who had committed the fraud; though if the horse had been stolen, and afterward sold in market overt, the title did not pass, and the owner could reclaim his property. To remedy this defect, various statutes have been enacted whereby the embezzling of the goods of a master by a servant, or by a clerk or person employed, provided such servant or clerk had the custody of the goods, was made felony; so of a guest in an inn, or a lodger in furnished rooms, carrying off any of the effects which he had possession of for use, it was declared to be larceny. Severe penalties are also enacted against embezzlement by clerks in the post office, or by brokers, bankers, attorneys, &c., of any moneys or valuable securities placed in their hands for safe keeping or any special purpose, or by persons intrusted with public moneys or property, munitions of war, &c.

**EMBLEMETS**, a term applied to the growing crops of land, produced annually by the labor

of the cultivator. By the common law, if the estate of a tenant for life or at will is terminated unexpectedly without his volition or default, the emblements belong to such tenant or his representatives; but if terminated by the act of the tenant himself, or if a tenant for years sows crops which do not mature within the life of the lease, the emblements pass with the land to the landlord; for the law does not relieve a man from the consequences of his own voluntary act.

**EMBRACERY**, an attempt to influence a juror by any unlawful consideration, as by private influence or by bribery. This was a criminal offence at common law, and the punishment has been prescribed by different statutes in England and the United States. The offence consists in the attempt, and it is not necessary that it should be successful.

**EMBRUN** (anc. *Eburodunum*), a fortified town of Dauphiny, France, in the department of Hautes-Alpes, 19 m. E. by N. of Gap; pop. in 1866, 4,736. It is a dreary-looking town of great antiquity, built upon a rock at whose foot flows the Durance. It contains a cathedral with a fine Romanesque tower, and near the former episcopal palace, which is used as a barrack, rises a quaint tower of ancient masonry known as *la tour brune*. The fortress is of the fourth rank, and is separated by a ditch from the mountain behind it. The principal manufactures are of woollen and linen goods.—The bishops (subsequently archbishops) of Embrun are traced back to the days of Constantine the Great, and were endowed by Conrad II. with princely power over a large part of Dauphiny. A portion of their archives was carried off during the wars of the league, and is now in the public library of Cambridge, England. Embrun was successively sacked by the Vandals, Huns, Saxons, and Moors; in 1573 it was taken by the Protestants, who razed the citadel; and in 1692 it was devastated by the duke of Savoy. Louis XIV. built the chateau of Mont-Dauphin in the vicinity.

**EMBRYOLOGY**, the study of the mode of formation and development of the animal fœtus. The progress of our knowledge on this subject has been marked by several well defined epochs, corresponding with the successive discoveries of as many different investigators. Though many important facts bearing upon embryology were known to the earlier anatomists and physiologists, they were often misinterpreted, and their true relations consequently mistaken. Aristotle and his followers recognized three different modes of generation as occurring among animals, viz. : oviparous, viviparous, and spontaneous generation. Oviparous generation was that form in which the female parent produced eggs, from which the young were hatched, as in most fishes, reptiles, and birds; viviparous generation was that in which the young were discharged alive and fully formed from the body of the parent, as in quadrupeds and the human species; while spontaneous or

equivocal generation was that in which certain animals of a low order, such as worms, insects, parasites, maggots, &c., were supposed to be produced spontaneously, without parents, from the soil, the water, or decaying animal and vegetable substances. By the progress of investigation, however, the last mode of generation was shown to be much less frequent in its occurrence than Aristotle had supposed. The first advance in this direction was made in the latter part of the 17th century, when Redi, an Italian naturalist, studied with care the generation and metamorphoses of insects, showing that many worms and maggots, instead of being produced without parents, were in reality hatched from eggs laid by perfect insects, and that they afterward became developed by the process of growth into forms similar to their parents. He also in 1684 showed that most parasitic animals were provided with sexual organs, and produced their young in the same manner with other and larger species. Vallisneri soon afterward (1700) extended the observations of Redi, and applied the same conclusions to other species of insects, and to the parasites inhabiting vegetables. In this way the number of species in which spontaneous generation was regarded as possible or probable gradually diminished, as zoological science became more extended and more accurate; until, in 1837, Schultze demonstrated, by his experiments upon the infusoria, that even these microscopic animalcules are never produced in situations where their germs neither existed before nor could gain access from without. Subsequently it was generally acknowledged by physiologists that spontaneous generation was a thing unknown in nature, and that the supposed instances of its occurrence were only cases in which the real process of generation had not been sufficiently investigated. The discussion on this point has again been taken up since 1858, and it has been maintained by Pouchet, Bastian, and others, that spontaneous generation may and does take place in the case of the lowest and most imperfectly known forms of infusoria, such as *vibrio*, *bacterium*, *monas*, and *spirillum*. Their experiments, however, are by no means regarded as conclusive by physiologists in general, a large proportion of whom consider the apparent uncertainty of origin as dependent on our imperfect acquaintance with the natural history and development of these minute forms of infusorial life.—The distinction between oviparous and viviparous animals was supposed by the ancients to indicate a fundamental difference in their mode of generation. In oviparous animals the eggs were known to be produced by the female and fecundated by the male, after which the young were hatched from them by incubation. In the viviparous species the embryo was thought to be produced by a mixture of the male sperm with the fluids of the female generative organs; some thinking that the material for the body of the embryo was supplied by the menstrual

blood, others that it came from a kind of female sperm, or seminal fluid secreted by the female organs. In 1651 Dr. William Harvey, in his book on generation, first announced the fact that there is no essential difference in the mode of generation between oviparous and viviparous animals, but that "all animals whatsoever, even the viviparous, and man himself not excepted, are produced from ova." But though the truth of this opinion has since been amply confirmed, and its expression (*omne animal ex ovo*) has now passed into a physiological aphorism, yet it was not intended by Harvey precisely in the sense which is now given to it. Harvey never saw the unimpregnated eggs of the quadrupeds, nor did he have any idea of the real structure and function of the ovaries in these animals; and in stating the opinion that the young of the vivipara and of man were produced from eggs, he only meant to say that after sexual intercourse and conception, the first thing produced in the uterus was not the embryo, but rather resembled an egg; and that the embryo was afterward formed from this by the process of growth. In 1672 Regneer de Graaf showed that the ovaries, in women and in female quadrupeds, were filled with globular vesicles, visible to the eye, similar in appearance to the eggs of birds and fishes. These vesicles he pronounced to be eggs; and the organs in which they were found then took the name of ovaries. A century and a half later (1827) Karl Ernst von Baer discovered by the microscope the real egg of the human female and of the viviparous animals, which is contained in the interior of the vesicles of De Graaf. These eggs were shown to exist in the ovaries of virgin females, as well as of those in whom sexual intercourse had taken place; and it was accordingly demonstrated that in all animals and in man the eggs are formed originally in the ovaries of the female, independently of the male, and that these eggs are afterward fecundated and developed into embryos. Another important discovery remained to complete our knowledge on this part of the subject, viz., that of the spontaneous ripening and discharge of the eggs, in quadrupeds and in man. Négrier (1840), Pouchet (1842), and Bischoff (1843) demonstrated that the eggs of the female, originally produced in the ovaries, ripen and are discharged, independently of sexual intercourse, at certain regular periods; and that the impregnation of these eggs by the male sperm is a subsequent process, taking place after the eggs have left the ovary and entered the Fallopian tubes. The origin of the embryo accordingly takes place in the same manner in all classes of animals, viz.: from an egg, which is produced in the ovary of the female, discharged thence at certain definite periods, and afterward fecundated by contact with the spermatic fluid of the male; and the only real difference between oviparous and viviparous animals is that in the former species (ovipara) the fecundated egg is discharged from the body of the female and

deposited in the nest, or other suitable receptacle, in which it is afterward hatched; while in the latter (vivipara) it is retained in the body of the female, and there nourished during the development of the embryo. The egg, at the time of its discharge from the ovary, consists of a globular vitellus or yolk, surrounded by a membrane termed the vitelline membrane,

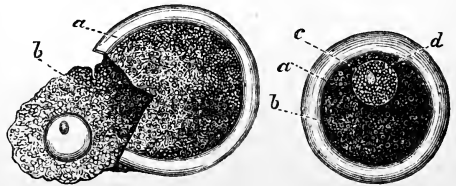

Mammalian Egg, highly magnified.

a. Vitelline membrane. b. Vitellus. c. Germinative vesicle. d. Germinal spot. In the left-hand figure the egg is shown burst open by the rupture of the vitelline membrane and the vitellus partly escaping.

and containing a spherical vesicle termed the "germinative vesicle," marked with the "germinative spot." In very many instances this becomes surrounded, while passing downward through the Fallopian tubes or ducts, with a layer of transparent albuminous matter; as for example, in the eggs of frogs, tritons, &c. In other cases, in addition to the albuminous matter, certain membranous coverings are deposited round the egg, of a fibrous and calcareous texture, as in birds and the scaly reptiles. In all instances, however, it is the vitellus which is the essential part of the egg, and that from which the embryo is directly produced.—The first change which occurs after the impregnation of the egg is a spontaneous division or segmentation of the vitellus. The vitellus divides successively into smaller and smaller portions, in such a way as to produce at last a multitude of minute flattened bodies or cells, which are attached edge to edge, and which form accordingly a continuous membrane, which is called the blastodermic membrane. In eggs which have a large-sized yolk, as those of the birds, lizards, and turtles, the formation of the blastodermic membrane begins at a particular spot on the surface of the vitellus, termed the *cicatrice*, and thence spreads in every direction, so as to enclose gradually all the rest of the yolk. But in those which are of minute size, as in quadrupeds and the human species, the whole vitellus is converted into the blastodermic membrane, which after its formation encloses only a small cavity filled with transparent, watery fluid. The blastodermic membrane then becomes variously altered and developed in different parts so as to form the various organs and tissues of the embryo. A line or furrow first shows itself in the thickest and most condensed portion, known as the primitive trace. This indicates the future situation of the spinal column; and the different parts of the vertebrae gradually grow around it, forming a chain of cartilaginous rings, with

transverse and oblique processes, which envelope the primitive trace or furrow, and convert it into a closed canal, large and rounded at the anterior extremity, or head, but narrow and pointed at the posterior extremity, or tail. In this canal the brain and spinal cord are formed and complete the development of their various parts. At the same time the remainder of the blastodermic membrane becomes more condensed and organized, forming the integument and muscles of the chest and abdomen; and these portions finally unite with each other in front, forming at the point of junction a longitudinal or rounded cicatrix, known as the umbilicus. The alimentary canal, formed in the interior of the abdominal cavity, is at first entirely closed; but two openings are afterward formed, one at the anterior extremity of the body, the other at the posterior. These openings become respectively the mouth and anus. In frogs, tritons, and some kinds of fish, all these changes take place after the eggs are discharged from the body of the female. In birds and turtles the segmentation of the vitellus and the formation of the blastodermic membrane are already far advanced at the time the eggs are laid. In the lizards, most serpents, and some kinds of cartilaginous fishes, the development of the embryo takes place partly while the egg is still in the generative passages of the female, and partly after its expulsion. In a few species of serpents, and in some fishes, the embryo is completely developed within the egg in the body of the female, so that the young are finally brought forth alive; while in all the warm-blooded quadrupeds, as well as in the human species, the fecundated egg is also retained in the uterus until the embryo is sufficiently developed to be born alive.—In the frog, the eggs are deposited in the early spring, in some shallow pool, freely exposed to the light and air. Immediately after their expulsion the albuminous matter with which they are surrounded absorbs water and swells up into a tremulous and gelatinous mass, which floats near the surface, with the eggs imbedded in its substance. The formation of the embryo then goes on as above described, and the young animal, at first curled up in the interior of the vitelline membrane, soon ruptures it and effects its escape. The body is at this time of an elongated form, terminating behind in a narrow, compressed tail. The integument is covered with vibrating cilia, which produce a constant current of fresh water over the surface of the body. Respiration is performed by gills, situated at the sides of the neck, which are at first exposed, but afterward become covered by a fold of integument. The muscular system is very feeble, and the young animal remains nearly motionless, attached by the mouth to the gelatinous matter around the eggs, upon which he feeds for several days. As he increases in size and becomes stronger, he abandons the spawn and swims about freely in the water, feeding upon the juices and tissues of aquatic vegetables.

The cilia with which the body was covered disappear. The alimentary canal is at this time very long in proportion to the size of the whole body, being coiled up in the abdomen in a spiral form. During the summer lungs are developed in the interior, and the young tadpole frequently comes to the surface to take in air. But the gills also continue in existence, and are still the most active organs of respiration. Toward the end of the season anterior and posterior extremities or limbs begin to grow; the posterior sprouting externally from each side, in the neighborhood of the anus; the anterior remaining concealed under the integument, just below the situation of the gills. The tadpole passes the winter in this transition state. The next spring the lungs increase in size, and the gills become less active as organs of respiration. The anterior extremities are liberated from their confinement by a rupture of the integument which covered them, and both anterior and posterior limbs grow rapidly in size and strength. The tadpole at this time, therefore, has both fore and hind legs and a tail. The tail early in the summer becomes atrophied, and finally withers and disappears altogether; while the limbs, and especially the hind legs, grow to a larger size. At the same time, the lungs attaining their full development and the gills finally disappearing, the tadpole is thus converted into a perfect frog, capable of living and moving upon the land as well as in the water. The tadpole swims by the tail and breathes by gills, while the frog swims by the legs and breathes by lungs. Simultaneously with these changes, the alimentary canal becomes very much shorter in proportion to the rest of the body, and the frog becomes carnivorous in its habits, living principally upon insects, which he is enabled to capture by the great development of his muscular system, and the rapidity and suddenness of his movements.—The process of development of the embryo consists, accordingly, in the successive formation and disappearance of different organs which are adapted to different modes of life. When these changes take place after the young embryo has left the egg, as in the case of the frog, and so produce marked alterations in the external form of the body, they are termed transformations or metamorphoses. Thus the egg of the butterfly, when first hatched, produces a caterpillar, or larva; an animal with a worm-like body, sluggish crawling movements, and no sexual apparatus, but furnished with largely developed digestive organs and a voracious appetite. This condition is succeeded by the pupa state, in which the animal changes its skin, losing the legs and bristles which were his locomotory organs, and becomes motionless and nearly insensible to external impressions, and stops feeding altogether. During this period another integument grows underneath the old one, with new legs and wings; and when the skin is again changed, the animal appears as a



perfect insect, or imago, capable of rapid and sustained flight, ornamented with brilliant colors, provided with different sensory and digestive organs and a well developed sexual apparatus.—In those instances where the hatching of the egg is a longer process, similar changes to the above take place while the embryo is still retained in its interior. At the same time certain other organs are formed in addition, which either disappear before the time of hatching, or are thrown off when the young animal leaves the egg. With turtles, for example, the eggs, consisting of the vitellus, albumen, and shell, are deposited in an excavation in the earth or sand, and allowed to hatch in these situations. With birds, they are placed usually in nests, formed of twigs, leaves, and fibres, and there kept constantly warmed and protected by contact with the body of the female parent. This process is termed incubation, and may be imitated artificially by keeping the eggs at a temperature of 104° F. and providing for the regular supply of fresh air and a proper regulation of the atmospheric moisture. During incubation the eggs of the common fowl lose 12 per cent. of their weight, of which 11 per cent. is due to the exhalation of moisture. They also absorb oxygen and exhale carbonic acid. The segmentation of the vitellus and formation of the blastodermic membrane, and of the organs of the embryo, take place for the most part according to the plan already described, but variations present themselves which make the process more complicated. The vitellus, for example, instead of being entirely surrounded by the abdominal walls, is divided into two portions by a constriction situated about its middle. One of these portions remains outside the abdomen of the embryo, though still connected with it by a narrow neck, and by blood vessels which ramify upon its surface. This sac, containing a portion of the vitellus, is called the umbilical vesicle. It supplies the embryo with nourishment during the whole period of incubation; for immediately after the egg is laid the albumen, which is at first gelatinous in consistency, begins to liquefy near the upper surface, and the liquefied portions are immediately absorbed into the yolk. The yolk, therefore, grows larger and more fluid than before, while the albumen diminishes in quantity, and loses its watery portions. The blood vessels of the embryo, ramifying over the surface of the vitellus and the umbilical vesicle, in their turn absorb the nutritious fluids from it, and convey them into the interior of the body, to be used in the formation of the tissues. At the end of incubation the albumen has disappeared and the umbilical vesicle has much diminished in size, while the body of the chick has increased at the expense of both; but the umbilical vesicle, containing the remains of the yolk, still exists, and is enclosed within the abdominal walls when the chick leaves the egg. In quadrupeds and the human species the umbili-

cal vesicle is much smaller in proportion to the body, and less important in function, than in birds and the scaly reptiles. In the human embryo the umbilical vesicle, always very small, diminishes rapidly soon after the end of the third month, and is hardly distinguishable during the latter period of gestation. In the egg of the fowl certain accessory membranes or envelopes begin to grow around the embryo at an early period. The first of these is the amnion, which is formed by a double fold of the blastodermic membrane, rising up about the edges of the body of the embryo, so as to surround it by a kind of circumvallation, or embankment. By continued growth these folds at last approach each other and meet over the back of the embryo, forming by their union and adhesion an enclosing membrane, or sac, which is the amnion. The amnion, therefore, is a membranous envelope, which is closed over the back of the embryo, but which remains open in front of the abdomen. About the same time a vascular, membranous diverticulum grows out from the alimentary canal, near its posterior extremity, and emerging from the open part of the abdomen turns upward over the back of the embryo, outside the amnion, and just inside the shell membranes. This vascular membrane is the allantois, an organ which surrounds the embryo in quadrupeds, birds, and some reptiles, and which serves as an organ of nourishment, or for the aëration of the blood. It first makes its appearance in the early stages of embryonic life, as we have mentioned, in the form of a protrusion or offshoot from the lower part of the alimentary canal. It rapidly increases in extent, protrudes further from the abdomen, spreads laterally in every direction, and thus finally envelopes the body of the fœtus; its edges, as they come in contact with each other from opposite directions, in many species becoming adherent, so as to form a continuous membrane. This membrane, which in the bird's egg is situated immediately underneath the shell, is abundantly supplied with blood vessels coming from the interior of the abdomen of the embryo, and returning thither after having ramified upon the surface of the allantois. It is by this means that the absorption of oxygen and exhalation of carbonic acid take place, which are so distinctly marked in the fowl's egg during the latter period of incubation. The allantois in these animals is accordingly an organ of respiration for the fœtus. Toward the latter period of incubation the allantois becomes very closely adherent to the egg shell, and the shell itself grows thinner, more porous, and more fragile; whence it is believed that the allantois also serves to absorb calcareous matter from the shell, which it conveys into the interior of the body, to be used in the formation of the bones, the ossification of which takes place about this period. When the chick is sufficiently developed to leave the egg, usually at the end of the 21st

day, by a sudden movement it strikes its bill through the end of the attenuated and brittle egg shell, and by inhaling the air and continuing its struggles, finally extricates itself from the cavity of the shell, leaving the allantois adherent to its internal surface. The blood vessels of the allantois are torn off at the umbilicus, which afterward closes and unites by a permanent cicatrix.—Another important change which takes place in the development of birds and quadrupeds, in addition to those presented by frogs and fishes, is the formation of the urinary apparatus. In fishes and batrachians the urinary organs are two long glandular bodies situated on each side the spinal column, which are known as the Wolffian bodies, and which remain permanent throughout the life of the animal, no true kidneys ever being produced. But in birds and quadrupeds the Wolffian bodies, which are at first very large and important organs, disappear during the progress of embryonic development, while the kidneys are formed at the same time, and gradually take their place as urinary organs. The kidneys are accordingly substituted for the Wolffian bodies in these instances, very much as lungs are substituted for gills in the development of the frog.—In many species of quadrupeds the allantois attains a large size, and performs a very important function, during intra-uterine life. In the ruminating animals, cows, sheep, goat, deer, &c., it forms an elongated sac, taking the form of the uterine cavity, and lying in close contact with the lining membrane of the uterus. The cavity of this sac communicates with the cavity of the posterior part of the intestine, from which it was originally developed, and receives the secretion of the Wolffian bodies, and afterward of the kidneys. Its exterior is covered with a large number (60 to 80) of tufted vascular prominences, which are entangled with similar elevations of the uterine mucous membrane, called cotyledons; and the blood of the embryo, while circulating through these bodies, absorbs from the maternal vessels the materials requisite for its nutrition. In the pig the allantois is nearly smooth on its external surface, merely presenting transverse folds and ridges, which lie in contact with similar inequalities of the uterine mucous membrane. In the carnivorous animals its middle portion is shaggy and vascular, and entangled with the blood vessels of the uterus, while its two extremities are smooth and unattached. In the human embryo the amnion is formed in the same manner as already described; but the allantois, instead of constituting a hollow sac, with a cavity containing fluid and communicating with the intestine, spreads out into a continuous flattened membrane, the two layers of which are in contact with each other and adherent, leaving consequently no cavity between them. It extends, however, quite round the fetus, enveloping it in a continuous vascular membrane, which here takes the name

of the chorion. The chorion is, accordingly, the same thing in the human species as the allantois in the lower animals, except that its cavity is obliterated by the adhesion of its walls. It is covered uniformly at an early date with tufted villousities, which become entangled with the mucous membrane of the uterus. But during the third month it begins to grow smooth over the greater portion of its surface, while at a certain part the villous tufts grow more rapidly than before, until they are finally converted into a thick vascular, spongy, and velvety mass of villousities, which penetrate into the uterine mucous membrane, and become adherent to its blood vessels. This organ is then termed the placenta; and from that time forward it serves the fetus as an organ of absorption and nourishment, its blood vessels imbibing from the circulation of the mother the albuminous fluids which it requires for growth and nutrition.—The amnion in the human species is at an early period so arranged that it closely invests the body of the embryo, while between it and the chorion there is interposed a thick layer of soft gelatinous material. During the second and third months the cavity of the amnion enlarges, by the accumulation of a watery and albuminous fluid (the amniotic) in its interior, while the gelatinous matter between it and the chorion is gradually absorbed and disappears, in order to make way for its expansion. By this enlargement the amnion approaches nearer the internal surface of the chorion, and by the beginning of the fifth month the two membranes come in contact with each other. By this means the fetus becomes enclosed in a large cavity (the amniotic cavity), filled with fluid, so that a free space is allowed for the movements of the fetal limbs. These movements begin to be perceived about the fifth month, at which time quickening is said to take place. They afterward become more strongly pronounced, and before birth are frequently very active. These movements are also favored by the formation and growth of the umbilical cord. The blood vessels of the fetus, termed the umbilical vessels, which pass out from the abdomen to the placenta and the chorion, become much elongated, and at the same time covered with a deposit of firm gelatinous matter, the whole being surrounded by a prolongation of the membrane of the amnion. This bundle of vessels, covered with the above investments, is termed the umbilical cord. It grows very long, and also becomes spirally twisted upon its own axis, usually in a direction from right to left. There are in the latter periods of gestation two umbilical arteries, carrying the blood of the fetus outward to the placenta, and one umbilical vein, in which it is returned to the body and the internal venous system.—The formation of the blood and blood vessels in the embryo takes place at a very early period. Soon after the production of the blastodermic membrane, some of the cells of which it is

composed break down, or separate from each other in such a manner as to leave irregular spaces, or canals, which inscuate with each other by frequent communications. These canals are destined afterward to become the blood vessels, the structure of which is gradually perfected by the growth of fibrous tissue in their walls, and their complete separation from the neighboring parts. In the interior of these canals, or imperfectly formed blood vessels, there is to be seen at first only a transparent, colorless fluid, holding in suspension a few large, roundish, nucleated cells, which move sluggishly to and fro, as the current of the circulating fluid begins to be established. These cells do not differ much at this period from those which constitute the general mass of the neighboring tissues; but soon afterward they begin to be modified in their appearance, and give place to true blood globules. Their surface becomes smooth, and a reddish coloring matter is produced in their interior, which gives them a tinge similar to that of the red globules of the blood in the adult condition. The red blood globules of the foetus, however, still differ in several important particulars from those of the adult. They are considerably larger and more globular in shape, and have also a very distinct nucleus, which is wanting in the blood globules of the adult, at least in the quadrupeds. They increase in numbers also at this time by spontaneous division, one globule becoming divided into two, which separate from each other and afterward become themselves divided in a similar manner. In this way the quantity of the blood globules is very rapidly increased, and they soon become also still further altered in form and structure. They diminish in size, become in the human subject and the quadruped flattened and biconcave in form, and finally the nucleus disappears. These changes are all effected during fetal life, and chiefly during the early months, so that at the time of birth the blood globules have already the characteristics which distinguish them in adult life. The multiplication of the blood globules by subdivision is a process which takes place only in the embryo. The perfectly formed blood globules increase in number in some other way, probably by the isolated production and growth of new cells.—At the time of birth the foetal membranes (amnion and chorion) are ruptured, and the foetus escapes. The umbilical cord being at the same time divided and tied, the portion still connected with the foetus soon shrivels and separates by spontaneous ulceration, while the spot at which it was attached heals in a few days, leaving a cicatrix on the middle of the abdomen, which is permanent throughout life, and which is called the umbilicus.—The limbs grow, by a kind of budding or sprouting process, from the side of the body. They are at first mere rounded eminences, without distinction of parts or articulations; but they subsequently become successively divided into fingers and toes, and

the different joints of the arm and leg. The upper extremities during the greater part of foetal life are larger than the lower, but afterward the lower extremities and the pelvis grow faster than the arms and shoulders, and finally become after birth much the larger of the two. The lungs are small and solid in texture before birth, but immediately afterward they expand by the inhalation of air, and receive a much larger supply of blood than before. On the other hand, the liver is much larger in proportion to the rest of the body at an early period than subsequently. In some animals it amounts during the first part of foetal life to 12 per cent. of the entire weight of the body, and is reduced to 3 or 4 per cent. at the time of birth. In the human subject it is equal at birth to  $3\frac{1}{2}$  per cent. of the entire weight, but is reduced in the adult to less than 3 per cent. Great changes take place also during foetal life in the anatomy of the heart and circulatory system, as well as in the relative size and development of nearly all the organs in the body. These changes continue to take place after birth, though less rapidly than before, and the entire process of development is not regarded as complete until the individual has reached the adult condition.—A very singular modification of the above process of embryonic development among the mammalia occurs in the marsupial animals, of which the American opossum (*Didelphys Virginiana*) is a representative. In these animals the eggs are impregnated and the formation of the embryo commenced in the usual way; but after remaining for a comparatively short time in the uterus, and while their development is still very incomplete, the embryos are discharged from the generative passages, and are immediately afterward found attached by the mouth to the teats of the parent. They are then less than half an inch in length, and quite gelatinous and embryonic in appearance. They are protected by a double fold of the integument of the abdomen, which forms a kind of pouch, surrounding the teats, and serving to enclose the young and helpless embryos. They remain in this situation during the completion of their development, continuing attached for the most part to the teats, from which they derive nourishment; and even after they have become capable of running about by themselves, they still, upon an alarm, take refuge for a time in the pouch as before. It is not known how the young embryos, when expelled from the uterus, find their way into the external pouch so as to reach the teats, for, notwithstanding many attempts have been made to ascertain this point, the animal is so secret in her habits at the time of delivery that they have been thus far entirely unsuccessful.—Among invertebrate animals the egg is constituted, as a general thing, in nearly the same way as in vertebrata, and its impregnation takes place also in a similar manner. The segmentation of the yolk goes on by repeated subdivisions, until the whole vitellus is converted into a mulberry-shaped mass out of which the embryo is formed.

While, however, in the vertebrate animals, the embryo always lies with its belly upon the surface of the yolk, in some of the invertebrates, as the articulata (insects, spiders, crustaceans), the back of the embryo is in contact with the yolk, and the closing up or union of the two sides of the body takes place along the dorsal line, instead of the abdominal. In many mollusks, as for example in snails, the embryo, soon after the commencement of its formation, begins to rotate slowly in the interior of the vitelline sac; and this rotation continues more or less rapid until the hatching of the egg. In the invertebrate classes the metamorphoses or transformations of the young animal are more frequent and more striking than in vertebrata. In many of them the young animal when first hatched from the egg is entirely unlike its parent in structure, external appearance, and habits of life. In the class of insects many of these transformations are well known, and have always attracted the attention of the curious. Frequently the young animal, in passing through several successive transformations in which he is adapted to different modes of life, necessarily changes his habitation; and being found accordingly in totally different localities, and presenting at successive intervals corresponding differences of organization, the same embryo at different ages is often mistaken by the ignorant for an entirely distinct species of animal. These changes of habitation, occurring in the course of embryonic development, are termed migrations. They are often very marked in parasitic animals. Thus the tænia, or tapeworm, inhabiting the small intestines of certain animals, such as the dog, cat, &c., produces an egg containing a small globular embryo, armed with certain hard spikes, or curved prominences, capable of being moved by muscular fibres inserted into their base. The portion of the tapeworm in which these eggs are contained, known as the proglottis, is discharged from the intestine of the first animal, and the eggs, becoming mixed with vegetable matter, are devoured by animals belonging to other species, as for example the pig. Either in the process of mastication, or by the action of the digestive fluids of the stomach, the external envelope of the egg is destroyed, and the embryo set free. By means of its movable projecting spines, the embryo then makes its way through the walls of the stomach or intestine into the neighboring organs, and often reaches distant parts of the body. Here, becoming arrested, it is temporarily fixed in place by the consolidation of the tissues round it, and becomes enlarged by the imbibition of fluid, assuming a vesicular form. A portion of this vesicle becomes inverted, and at the bottom of the inverted part a head is produced, upon which there are formed four muscular disks, or suckers, and a circle of calcareous spines or hooks, different from those present at an earlier period, which are thrown off and lost. In this state the animal receives the name of *scolex* or

*cysticercus*. It remains in that condition till the death of the animal whose tissues it inhabits, when, being devoured with the flesh by an animal belonging to the first species, it passes into the intestine of the latter, and there becomes developed into the complete tapeworm, or *strobila*, similar to that from which its embryo was first produced. The same animal is accordingly a parasite in different organs, and even in different species, at different periods of its development. Some of the invertebrata are parasitic at one stage of their existence, and lead an independent life at another. Such are the small crustacea which infest the bodies and gills of certain fishes. In the family of *æstridæ*, or bot flies, the eggs are deposited by the female insect, and attached to the hairs of horses, cattle, &c.; from which situation, after the embryo has become partly developed, they are detached in some instances (as in *gastrophilus equi*) by licking, and swallowed into the stomach. Here the larva is set free, and attaches itself to the mucous membrane of the stomach, nourishing itself upon the fluids obtained from this source, and gradually increasing in size. After a certain period the larva lets go its hold, passes through the intestine, is discharged with the fæces, and, assuming the pupa state, is finally transformed into the perfect insect. The process of embryonic development is accordingly a succession of changes, in which the structure and organization of the young animal are adapted to different modes of existence, and in which different organs and apparatuses, successively appearing and disappearing, replace each other in the progress of growth, and give rise to the appearance of transformations, which affect the body as a whole.—See Harvey, *Exercitationes Anatomicae de Generatione Animalium* (London, 1651; Sydenham edition, London, 1847); Spallanzani, *Saggio di osservazioni microscopiche*, &c. (Modena, 1767), *Prodromo sopra le produzioni animali* (Modena, 1768), and other works; Baer, *De Ovi Mammalium et Hominis Genesi Epistola* (Leipsic, 1827), and *Ueber Entwickelungsgeschichte der Thiere* (1828); Valentin, *Handbuch der Entwickelungsgeschichte des Menschen* (Berlin, 1835); Coste, *Recherches sur la génération des mammifères* (Paris, 1834), *Embryogénie comparée* (1837), and *Histoire générale et particulière du développement des corps organisés* (1847, '49, '53); Pouchet, *Théorie positive de la fécondation des mammifères* (1842), and *Théorie positive de l'ovulation spontanée et de la fécondation des mammifères et de l'espèce humaine* (1847); Bischoff, *Reifung und Loslösung der Eier der Säugethiere und der Menschen* (Giessen, 1844), and his treatises on the embryology of the hedgehog (1853), ape (1866), &c.; Rathke, *Ueber die Entwickelung der Schildkröten* (Brunswick, 1848), *Flusskrebs* (1829), *Columber Natriz* (1839), *Krokodille* (1866), &c.; Agassiz, "Lectures on Comparative Embryology" (Boston, 1849); H. Baudrimont and Martin Saint-Ange,

*Du développement du fœtus* (Paris, 1850); Bergmann and Leuckart, *Vergleichende Anatomie und Physiologie* (Stuttgart, 1852); Kölliker, *Entwicklungsgeschichte des Menschen und der höheren Thiere* (Leipsic, 1861); Ernst Haeckel, *Generelle Morphologie der Organismen*, vol. ii., *Die Wissenschaft von den entstehenden organischen Formen* (Berlin, 1866).

**EMBURY, Emma Catharine**, an American authoress, born in New York in 1806, died in Brooklyn, N. Y., Feb. 10, 1863. She was the daughter of Dr. James R. Manley of New York, and was married to Mr. Daniel Embury in 1828. In the same year she published "Guido and other Poems." She frequently contributed to periodicals poems and tales, most of which afterward appeared in a collected form, under the titles of "The Blind Girl and other Tales," "Glimpses of Home Life," and "Pictures of Early Life." In 1845 she supplied the letterpress, both prose and verse, to an illustrated gift book entitled "Nature's Gems, or American Wild Flowers," and in the succeeding year published a collection of poems called "Love's Token Flowers." In 1848 she published "The Waldorf Family, or Grandfather's Legends," a fairy tale of Brittany, partly a translation and partly original.

**EMBURY, Philip**, the first Methodist minister in America, born in Ballygaran, Ireland, Sept. 21, 1729, died at Camden, Washington co., N. Y., in August, 1775. He was of German parentage, was educated at a school near Ballygaran, and learned the carpenter's trade. In 1758 he joined the Irish Methodist conference as a preacher. He emigrated to America in 1760, settled in New York as a carpenter, and in 1766, upon the advice of Barbara Heck, commenced preaching, first in his own house, and soon after in a rigging loft, afterward famous as the birthplace of Methodism in New York. The first Methodist church was erected under his charge in 1768, on the site of the existing John street church, he himself working upon the building as a carpenter. He preached here without salary until the arrival in 1769 of missionaries sent out by Wesley, when he resigned and emigrated to Camden, where he worked at his trade during the week, and preached on the Sabbath. He organized a Methodist society, chiefly of Irish emigrants, at Ashgrove, seven miles distant from Camden, being the first Methodist organization within the bounds of what is now the Troy conference. He died suddenly, in consequence of an accident in mowing, and was buried on a neighboring farm; but in 1832 his remains were removed to Ashgrove churchyard, and in 1866, by order of the Troy conference, to the Woodland cemetery, Cambridge, N. Y.

**EMDEN**, or **Embsden**, a seaport town of Prussia, in the province of Hanover, on the Dollart estuary, near the mouth of the Ems, 45 m. N. W. of Oldenburg; pop. in 1871, 12,588. The harbor is shallow, but the roadstead is capable of accommodating large vessels. Canals

intersect the town in various directions; one connects it with the town of Aurich, and another (opened in 1847, at a cost of \$300,000) with the Ems. It is protected by a high and strong embankment against the incursions of the Dollart, from which it has frequently suffered. Although the town has declined in population and prosperity, it continues to be the most important commercial town of Hanover. About 400 vessels enter and leave the port annually, and ship building is extensively carried on. Emden is of very ancient origin, and resembles more a Dutch than a German town. In the present century it has passed through the hands of Prussia, Holland, and France, came to Hanover in 1815, and in 1866 was again incorporated with Prussia.

**EMERALD** (Sp. *esmeralda*; Gr. *σμάραγδος*, from *σμάρασσειν*, to shine, whence the old name of smaragd and the German *Smaragd*), a name given to the finest crystals of the mineral species beryl, transparent and of rich green colors derived from oxide of chrome, which is present in the proportion of about 1 per cent., but, according to Vauquelin, sometimes as much as 3.5 per cent. (See **BERYL**.) They are found in metamorphic rocks, the granites, and mica schists. The finest specimens come from near Muzo, N. N. W. of Bogotá, South America. Here it occurs in isolated crystals or in nests in a clay slate, a rock containing cretaceous fossils in its limestone concretions, and not in veins, as has been stated. A perfect hexagonal crystal from this place, 2 in. long and measuring across its three diameters  $2\frac{1}{2}$ ,  $2\frac{3}{4}$ , and  $1\frac{1}{4}$  in., and weighing 8 oz. 18 dwts., is in the cabinet of the duke of Devonshire. A still finer specimen, but only 6 oz. in weight, is in the possession of Mr. Hope, and cost £500. Emeralds of much larger size, but of less beauty, are found in Siberia, on the river Tokovoya, in mica schist. One in the royal collection is  $14\frac{1}{2}$  in. long by 12 broad, and weighs  $16\frac{1}{2}$  lbs. troy. The true emeralds of the ancients are said to have been principally obtained from Mt. Zabarah in Upper Egypt, where the old workings were discovered by the French traveller M. Cailliaud, and reopened by Mehemet Ali. They are, however, inferior to the South American gems. The Peruvian emeralds were famous from the time of the conquest of that country by Pizarro. They were obtained in the barren district of Atacama, and worked by the native artists with the skill of the modern lapidary. To this day a river and a village of Ecuador are known by the name of Esmeraldas, from the abundance of emeralds formerly found in that region. Mexico at the same early period had produced crystals of rare beauty, which were no less appreciated and highly valued by the rulers of the Aztecs than were those of Peru by its incas. For one of the fine emeralds brought by Cortes on his return to Europe some Genoese merchants are said to have offered him 40,000 ducats. They had been cut by the exquisite workmanship of the

Aztecs, one in the form of a rose, the second in the form of a horn, the third like a fish with eyes of gold, and the fourth like a little bell, with a fine pearl for the tongue; the fifth, which was the most valuable, was a small cup with a foot of gold, and with four little chains of the same metal attached to a large pearl as a button. From these sources were probably obtained the magnificent emeralds now in the royal collection at Madrid, some of which are stated to be as large as those of the duke of Devonshire, and of the finest water. The emerald has long been highly esteemed, ranking in value next to the diamond and the ruby. Pliny states that in his time those of considerable size, which were free from defects, were sold at enormous prices.—The color of the emerald is of a finer green than that of any other stone, having different shades, some of verdigris or grass green, and some of a paler hue. They all appear best by daylight, and to retain their effect by candle light they require to be set with small diamonds or pearls. Emeralds are generally cut in the form of a square table, with bevelled edges, the lower surface being cut into facets, parallel to their sides. Beudant, in his *Minéralogie*, gives the value of emeralds of fine colors, and free from flaws, as follows: one of 4 grains, 100 to 120 francs; of 8 grains, 240 francs; of 15 grains, as high as 1,500 francs; and he cites a fine stone of 24 grains which was sold at 2,400 francs.—Immense emeralds are mentioned by ancient authors, but they were undoubtedly glass imitations. Such was the colossal statue of Serapis in the Egyptian labyrinth, 13½ ft. high; also an obelisk in the temple of Jupiter, 60 ft. high and 6 ft. broad, composed of four pieces. Sir J. Gardner Wilkinson remarks that the forming of these huge blocks of glass was a greater triumph of art than imitating the stones. Egypt was the country especially noted for the manufacture of artificial emeralds, and Pliny says that they succeeded so completely that it was “difficult to distinguish false from real stones.”—The oriental is not, like the true emerald, a silicate of alumina and glucina, but is a green, transparent variety of corundum, and therefore nearly pure alumina, differing from the sapphire only in color. It is the rarest of gems, and from this and its superior hardness, although inferior in color, it is highly prized. Mr. Emanuel of London says that he has only met with one specimen; but in the autumn of 1872 Dr. J. Lawrence Smith had sent to him from the territory of Montana a quantity of rolled pebbles, which were found to be corundum. They were flattened hexagonal prisms with worn edges, and were either colorless or green, varying in shade from light to dark; none were red. They are found on the Missouri river, near its source, about 160 m. above Benton, and are obtained from bars on the river, where considerable gold is also found. The corundum is scattered through the gravel, which is about 5 ft. in depth, lying upon the bed rock. It is

most abundant on the Eldorado bar, 16 m. from Helena. One man could collect on this bar from one to two pounds per day. Dr. Smith has had some of the stones cut, one of them very perfect, of 3½ carats, of a fine green, almost equal to the best oriental emerald.

**EMERALD HILL**, a municipal town of Victoria, Australia, 1½ m. S. of Melbourne; pop. in 1871, 17,121. It has a mechanics' institute with a library of 2,350 volumes, several public buildings, and a weekly newspaper. It was one of the earliest municipalities of the colony, being proclaimed in May, 1855.

**EMERSON, George Barrell**, an American educator, born in Kennebunk, York co., Maine, Sept. 12, 1797. He graduated at Harvard college in 1817, and soon after took charge of an academy in Lancaster, Mass. Between 1819 and 1821 he was the tutor in mathematics and natural philosophy in Harvard college, and in 1821 was chosen principal of the English high school for boys in Boston. In 1823 he opened a private school for girls in the same city, which he conducted till 1855, when he retired from professional life. He wrote the second part of the “School and Schoolmaster,” of which the first part was written by Bishop Potter of Pennsylvania, and is the author of a number of lectures on education. He was for many years president of the Boston society of natural history, and was appointed by Gov. Everett chairman of the commissioners for the zoölogical and botanical survey of Massachusetts. He has published a “Report on the Trees and Shrubs growing naturally in the Forests of Massachusetts” (Boston, 1846), and a “Manual of Agriculture” (1861).

**EMERSON, Ralph Waldo**, an American poet and essayist, born in Boston, Mass., May 25, 1803. He is the son of the Rev. William Emerson, pastor of the first church in that city. In his eighth year, on the death of his father, he was sent to one of the public grammar schools, and was soon qualified to enter the Latin school. Here his first attempts in literary composition were made, consisting of original poems recited at exhibitions of the school. He entered Harvard college in 1817, and graduated in August, 1821. He does not appear to have held a high rank in his class, though the records show that he twice received a Bowdoin prize for dissertations, and once a Boylston prize for declamation. He was also the poet of his class on “class day.” While at the university he made more use of the library than is common among students, and was distinguished among his classmates for his knowledge of general literature. For five years after leaving college he was engaged in teaching school. In 1826 he was “approbated to preach” by the Middlesex association of ministers; but his health at this time failing, he spent the winter in South Carolina and Florida. In March, 1829, he was ordained as colleague of Henry Ware, at the second Unitarian church of Boston. He belongs to a clerical race. For eight

generations, reckoning back to his ancestor Peter Bulkley, one of the founders of Concord, Mass., there had always been a clergyman in the family, either on the paternal or maternal side. He was the eighth in succession of this consecutive line of ministers. In 1832 he asked and received a dismissal from the second church, on account of differences of opinion between himself and its members touching the Lord's supper; and in December he sailed for Europe, where he remained nearly a year. On his return in the winter of 1833-'4 he began his career as a lecturer, with a discourse before the Boston mechanics' institute on the subject of "Water." Three others followed, two on Italy descriptive of his recent tour in that country, and the last on the "Relation of Man to the Globe." In 1834 he delivered in Boston a series of biographical lectures on Michel Angelo, Milton, Luther, George Fox, and Edmund Burke, the first two of which were afterward published in the "North American Review." In this year also he read at Cambridge a poem before the Phi Beta Kappa society. In 1835 he fixed his residence at Concord, Mass., where he has since lived. During the winter he delivered in Boston a course of 10 lectures on English literature. These were followed, in 1836, by 12 lectures on the philosophy of history; in 1837, by 10 lectures on human culture; in 1838, by 10 lectures on human life; in 1839, by 10 lectures on the present age; in 1841, by 7 lectures on the times; and since that period he has delivered several courses of lectures in Boston. A small volume entitled "Nature" (1836), an oration before the Phi Beta Kappa society, with the title of "The American Scholar" (1837), an address to the senior class of the Cambridge divinity school (1838), and "The Method of Nature" (1841), contained the most prominent peculiarities of his scheme of idealism, and by their freshness and depth of thought, and compact beauty of expression, allured many readers into becoming disciples. In 1840 a quarterly periodical called "The Dial" was commenced, with Miss Margaret Fuller as editor, assisted by A. B. Alcott, William H. Channing, Mr. Emerson, Theodore Parker, George Ripley, and others. It was published for four years, and during the last two years of its existence it was under the editorship of Mr. Emerson. In 1841 the first, and in 1844 the second series of his "Essays" were published. In 1846 he collected and published a volume of his poems. The next year he visited England to fulfil an engagement to deliver a series of lectures before a union of mechanics' institutes and other societies. In 1849 he collected in one volume entitled "Miscellanies" his "Nature" and nine lectures and college addresses, which had been previously issued in pamphlet form, or printed in "The Dial." In 1850 "Essays on Representative Men," a series of masterly mental portraits, with some of the features overcharged, was published. To the "Memoirs of Margaret

Fuller Ossoli," which appeared in 1852, he contributed some admirable interpretative criticism. In 1856 he published "English Traits," a work in which he seizes and emphasizes the characteristics of the English mind and people; and in 1860 "The Conduct of Life." His contributions to the "Atlantic Monthly" have been collected. "May Day and Other Pieces" (poems) appeared in 1867; "Society and Solitude" in 1870. A revised edition of his "Prose Works Complete" was published in 1869. Mr. Emerson has also delivered many unpublished addresses on slavery, woman's rights, and other topics of public interest; and he has been one of the most prominent of the lecturers who address the lyceums of the country.—As a writer, Mr. Emerson is distinguished for a singular union of poetic imagination with practical acuteness. His vision takes a wide sweep in the realms of the ideal, but is no less firm and penetrating in the sphere of facts. His observations on society, on manners, on character, on institutions, are stamped with sagacity, and indicate a familiar knowledge of the homely phases of life, which are seldom viewed in their poetical relations. One side of his wisdom is worldly wisdom. The brilliant transcendentalist is evidently a man not easy to be deceived in matters pertaining to the ordinary course of human affairs. His common-sense shrewdness is vivified by a pervasive wit. With him, however, wit is not an end, but a means, and usually employed for the detection of pretence and imposture. Mr. Emerson's practical understanding is sometimes underrated from the fact that he never groups his thoughts by the methods of logic. He gives few reasons, even when he is most reasonable. He does not prove, but announces, aiming directly at the intelligence of his readers, without striving to extract a reluctant assent by force of argument. Insight, not reasoning, is his process. The bent of his mind is to ideal laws, which are perceived by the intuitive faculty, and are beyond the province of dialectics. Equally conspicuous is his tendency to embody ideas in the forms of imagination. No spiritual abstraction is so evanescent but he thus transforms it into a concrete reality. He seldom indulges in the expression of sentiment, and in his nature emotion seems to be less the product of the heart than of the brain. Mr. Emerson's style is in the nicest harmony with the character of his thought. It is condensed almost to abruptness. Occasionally he purchases compression at the expense of clearness, and his merits as a writer consist rather in the choice of words than in the connection of sentences, though his diction is vitalized by the presence of a powerful creative element. The singular beauty and intense life and significance of his language demonstrate that he has not only something to say, but knows exactly how to say it. Fluency, however, is out of the question in a style which combines such austere economy of words with the determination

load every word with vital meaning. But the great characteristic of Mr. Emerson's intellect is the perception and sentiment of beauty. So strong is this, that he accepts nothing in life that is morbid, uncomely, haggard, or ghastly. The fact that an opinion depresses, instead of invigorating, is with him a sufficient reason for its rejection. His observation, his wit, his reason, his imagination, his style, all obey the controlling sense of beauty, which is at the heart of his nature, and instinctively avoid the ugly and the base. Those portions of Mr. Emerson's writings which relate to philosophy and religion may be considered as fragmentary contributions to the "Philosophy of the Infinite." He has no system, and indeed system in his mind is associated with charlatanism. His largest generalization is "Existence." On this inscrutable theme his conceptions vary with his moods and experience. Sometimes it seems to be man who parts with his personality in being united to God; sometimes it seems to be God who is impersonal, and who comes to personality only in man; and the real obscurity or vacillation of his metaphysical ideas is increased by the vivid and positive concrete forms in which they are successively clothed.

**EMERY**, an impure, granular variety of corundum, intimately mixed with hematite or with magnetic iron ore. It has the appearance of fine-grained iron ore, for which it was long mistaken. Often the crystals of corundum are separable by washing. Its extreme hardness, derived from the corundum, and the ease with which it is obtained in large quantities, have led to its extensive use in the arts, for grinding and polishing hard stones, metals, and glass. Some of the localities from which it is obtained in the Grecian archipelago, and in the vicinity of Smyrna and ancient Ephesus in Asia Minor, were probably known to the ancient Greeks and Romans, as the use of a substance of this nature seems to have been required by the lapidaries of Magnesia, Ephesus, Tralles, and Tyre. In later times the island of Naxos in the archipelago has furnished all the supplies of commerce, the mineral being shipped from the port of Smyrna, and known by the name of Smyrna emery. From 1835 to 1846 the trade in emery was a monopoly granted by the Greek government to an English merchant, who so regulated the supply as to raise the price from its former rate of \$40 a ton to about \$140. This monopoly was broken up and the whole trade changed in consequence of the discoveries of Dr. J. Lawrence Smith of the United States, who in the course of his explorations in the service of the Porte discovered in 1847 a number of localities of the mineral belonging both to the Turkish and Greek governments. By an arrangement with the former, operations were commenced in the same year at some of the localities and afterward extended to others, so that the price has since been reduced to \$50 a ton. At the Juma Dagh, 12 m. E. of the ruins of Ephesus, Dr. Smith found the

emery scattered about upon the summit in loose pieces of all sizes up to masses of several tons weight. The rock to which it belongs is a bluish metamorphic marble, reposing upon mica slate and gneiss. In this rock the mineral is found in nodules and in amorphous masses, some of which are several yards in length and breadth, and of the weight of 80 to 40 tons. The structure of this rock is compact and tolerably regular, but the surface presents a granular appearance. Unless traversed by fissures, the rock is broken with great difficulty, and attempts to drill it are made in vain from its wear upon the tools. As the transportation from the quarries is only on the backs of camels or horses, many of the heavier masses are necessarily left behind. Some of the blocks, however, yield to the hammer after being exposed for some hours to the action of fire. The color of the powder varies from dark gray to black; but its shade has no relation to its hardness, and is consequently no index of the value of the article. The relative degrees of hardness of different samples were determined by Dr. Smith by collecting the powder just coarse enough to pass through a sieve of 400 holes to the inch, and with weighed samples of this rubbing little test plates of glass till they ceased to be further reduced. The rubber was the smooth bottom surface of an agate mortar. The loss in weight experienced by the glass plates gave the relative values of the samples of emery. On this plan Dr. Smith prepared a table exhibiting the different degrees of hardness; and making use of sapphire of Ceylon as the standard of comparison, the hardness of which he called 100, and the effective wear of which upon glass was equal to about four fifths of its own weight, that of the best emery was about one half of its weight. This table, to which were appended the results of the analyses of many samples of the mineral made by Dr. Smith, was published in the elaborate articles which he furnished to the "American Journal of Science," second series, vols. x. and xi. The hardness of the sapphire as rated upon the mineralogical scale is 9, next to the diamond, which is 10. That of emery is not necessarily indicated by the proportion of alumina, for a part of this may be in combination with the silica. It seems to vary with the water present, those samples containing the least water being the hardest. In 1855 the annual production of emery was 2,000 tons of Naxos stone and 1,600 tons of Turkish. The whole business was concentrated in the hands of Mr. Abbott, who held the contract with the Greek government, extending for ten years, and had purchased the Turkish firman, unlimited in time, for the annual payment of \$55,000. An arrangement was entered into with the house of Messrs. John Taylor and sons of England to employ a capital of £120,000 in this business, and supply the emery either in the stone or powder to all parts of the world, with the guaranty of its being free from adulterations,



such as had previously impaired its qualities and reduced its value.—The principal consumption of the article is in polishing plate glass, and the increase of this business causes a constantly increasing demand for emery. The discovery of new localities is a matter of great importance, the few that are known in other parts of the world furnishing no supply capable of competing with that brought from the head of the Mediterranean. It is said to be found near Petschau in Bohemia, near Yekaterinburg in the Ural, near Miyask in the Ilmen branch of that range, and in Frederick valley, Australia. An extensive vein of emery, exhibiting blue crystals of corundum, was discovered a few years ago at Chester, Mass., by Dr. C. T. Jackson of Boston. The mineral, which had for some time been mistaken for magnetic iron ore, occurs associated with margarite, diaspore, and chlorotoid, in talcose schist. The "American Journal of Science" for September, 1873, contains an article by Dr. J. Lawrence Smith giving an account of the discovery of beds of corundum containing emery in North Carolina, Georgia, and Montana. The beds in North Carolina are very extensive; the corundum is described as being very beautiful, and is found in masses weighing from 600 to 800 lbs., "having large cleavages, and being remarkably free from foreign ingredients," and in such quantities as to admit of its use as a substitute for emery. It occurs in chrysolite or serpentine rocks, belonging to a regular system of dikes lying on the N. W. side of the Blue Ridge, at an average distance from the summit of about 10 m., and which have been traversed for 191 m. Dr. Smith remarks that through all the range the corundum forms a geognostic mark of the chrysolite, as it does of the calcareous rock containing corundum, described by him in Asia Minor, and belongs to the same geologic epoch. For a notice of the Montana mineral, see EMERALD.—Emery is prepared for use by crushing the stone under stamps, and sorting the powder into different sizes by appropriate sieves. For the most delicate uses of opticians it is separated in a small way by a system of washing over called by chemists elutriation. After being ground, the powder is thrown into water, or water containing gum arabic, or it may be oil, and allowed to subside for a certain number of seconds or minutes. The process being systematically conducted, the powder is sorted into many sizes, and named according to the time the fluid is allowed to stand before the substance in suspension is collected, as emery of 10 seconds, of 30 seconds, 2 minutes, 30, 60, 80 minutes, &c. Emery is applied to paper, thin cloth, and slips of wood, by dusting the powder upon these articles after they have been coated with thin glue. They are then ready for sale or for use under the name of emery paper, cloth, or sticks. Mixed with paper pulp and fine glass and rolled into sheets, it forms the patent razor-strop paper; and by a variety of other methods

it is prepared for convenient application to its numerous uses of grinding and polishing.

**EMETICS**, medicines used to produce vomiting. They may be divided into two classes, specific and irritant. The first class require for their operation absorption into the circulation, and they produce their specific effects whether they are absorbed from the stomach or injected directly into the blood. When taken internally their action does not commonly commence until after 20 or 30 minutes; then nausea, chilliness, and a feeling of weakness are produced, while the pulse is slow and soft; and as vomiting is induced, these give way to a flushed countenance, a warm skin, and a full pulse. The most important of these are tartar emetic (tartrate of antimony), potassa, ipecacuanha, and the lately discovered apomorphia, which is an artificial alkaloid, prepared, as its name indicates, from morphia. Tartar emetic has recently been supposed to produce its effect, like the second class, by an irritant action upon the mucous membrane of the stomach, to which it is either directly applied or by which it is excreted when injected into the blood. Apomorphia, when injected subcutaneously, acts with great rapidity and in much smaller dose than when given by the stomach. *Lobelia inflata*, or Indian tobacco, has been largely used as an emetic by botanic practitioners, but is exceedingly depressing in its effects. Irritant emetics, as sulphate of zinc, copper, mustard, &c., on the other hand, produce vomiting by their direct effect upon the lining membrane of the stomach. Their action is immediate and unpreceded by any nausea or other precursory symptoms. They are used chiefly in cases of narcotic poisoning, and of accumulation in the bronchial tubes, where from the feebleness of the patient it is desirable to shun the depression preceding the action of ordinary emetics, while full and prompt vomiting is required. Emetics were formerly used extensively in the treatment of a large variety of diseases; but the careful observation of recent times has greatly restricted their employment. They find their most appropriate use in relieving the stomach from an excess of food, or from indigestible food, and from poisons, and occasionally in the treatment of bronchitis and croup.

**EMIGRATION** (Lat. *e*, from, and *migrare*, to depart), the act of leaving the country or place where one has resided, in order to reside in another. The terms emigration and emigrant are strictly applicable only with reference to the country from which the migration is made, and the converse terms immigration and immigrant are used when express reference to the country into which it is made is intended; but in the unlimited sense of change of residence, the former are generally employed in connection with either the old or the new domicile.—Of the earliest migrations by which the fundamental features of European history have been defined, no records remain,

but numerous traces of them are found by the archæologist, ethnologist, and linguist. Emigration proper commenced when herdsmen congregated into nomadic tribes. Of such corporate emigration patriarchal history records some examples, as those of Abraham and Jacob. With the progress of agriculture and the growth of more definite political relations, trade, and commerce, began the emigration of single bodies of adventurers to distant countries. In this way, according to Hellenic traditions, Phœnicians, led by Cadmus, and Egyptians, led by Danaus and Cecrops, emigrated to Greece, the Heraclidæ from Greece to Asia Minor, and the Tyrrhenians to Italy. The exodus of the Israelites from Egypt to Canaan was a corporate emigration of a people, on account of religious and political oppression, for which modern history furnishes parallels in the Mormon emigration to Utah and the emigration of the Boers in southern Africa. During the historical times of ancient Greece emigration generally assumed the character of colonization. Many flourishing and powerful Greek colonies were thus sent forth along the shores of the Mediterranean and Black seas by Greece. The colonies of ancient Rome for the most part were rather outposts of an army and combinations of fortune hunters than settlements of men intending to found permanent residences. The great migration of the Germanic nations having destroyed the Roman empire, European society was for centuries subject to constant changes. Charlemagne changed the direction of German emigration from the south to the east and north. While from that time the movements of German nations toward Italy assumed the character of mere military conquests, their emigration conquered nearly the whole country between the Elbe and Vistula rivers from the Slavic race. A counter-current from Asia, which set in at various periods of the middle ages, consisting of Magyars and Tartars, was successfully resisted, and the tide was even turned upon Asia by the crusades; but at a later period another Asiatic race, the Osmanli Turks, succeeded in displacing the most decayed of Christian nations in southeastern Europe, while almost simultaneously still another Asiatic race (the Arabs) was expelled from the southwestern peninsula, Spain, to which they had emigrated eight centuries before.—In Europe, Russia was among the earliest to perceive the advantages of immigration. Peter the Great invited emigrants from all nations to settle in Russia. His successors followed the same policy by granting premiums and valuable privileges, such as exemption from taxation for a certain number of years, exemption from military duty, and free homesteads to colonists. Induced by these advantages, a large number of emigrants from the Palatinate settled in southern Russia about 1784. Immediately after the Napoleonic wars an extensive Germanic emigration to Russia (includ-

ing Poland) took place. The total number of Germans who emigrated thither between the years 1816 and 1826 is estimated at 250,000. The agricultural colonies of Vielovish in the government of Tchernigov, and Riebendorf in that of Voronezh, a manufacturing colony near Poltava, a Moravian settlement at Sarepta, and a number of German colonies in the Crimea, originated in this way. During the reign of Nicholas emigration to Russia ceased almost entirely, but it revived to a certain degree after the accession of Alexander II.—Individual emigration, as distinguished from the movements of nations, commenced on a large scale after the discovery of America. During the 16th century the nations in which the Roman element predominated, Spain, Portugal, and France, sent forth a great number of emigrants, most of them mere adventurers who did not intend to stay longer than might be necessary to become rich. The first attempts by the English to organize emigration to America likewise originated in adventurous designs. In such attempts 300 men and £40,000 were lost from 1585 to 1590. In 1606 more than 2,000 emigrants were sent from England to North America to seek for gold, but they perished miserably, and in 1609 but 60 remained. The Hakluyt company for the colonization of Virginia lost 9,000 men and £100,000. At last religious contests laid a firm foundation for the permanent settlement of the North American continent. The emigration of the Puritans and their successful establishment in New England served as an example to all those who in Europe were oppressed for the sake of their religion. Besides, the ground having been broken for the settlement of what are now the southern states of the Union, the fertility of their soil, their genial climate, and withal the still lingering hope of sudden enrichment by discoveries of precious metals, attracted large numbers of colonists. A strong tide of emigration from Germany set in toward Pennsylvania near the end of the 17th and during the 18th century; the Dutch colonized New York; the Swedes Delaware; Canada and Louisiana were settled by the French. Still the current of emigration to America during the 170 years of the colonial history was slow and tedious when compared with that which commenced after the war of independence, and especially when the success of American institutions had been tested by the experience of one generation. Since the formation of the government, the United States has been the principal point of emigration from Europe, and of late also from Asia, owing chiefly to the advantages presented to the laboring classes, who constitute the great bulk of emigrants. Immigration from whatever source has been regarded with favor by the government, and laws have been passed at different times for the regulation of emigrant ships and the protection and comfort of emigrants. During the latter part of the 18th and the early part of the 19th century

the practice prevailed in New York and Philadelphia of selling by public auction into temporary servitude emigrants who were indebted for their passage money and other advances. During the last century the prepayment of the passage by the emigrant was the exception, and its subsequent discharge by compulsory labor the rule. Ship owners and ship merchants derived enormous profits from this traffic, as they charged very high rates for the passage and added a heavy percentage for their risks. Adults were sold for a term of from 3 to 6 years, and children from 10 to 15 years. Servants signed indentures and were known as "indentured servants." The last sales of this kind took place in Philadelphia in 1818 and 1819.—During the early part of the present century there was little protection for emigrants during the sea voyage. Ship owners generally chartered the lower decks of their vessels to agents, who made temporary arrangements for the accommodation of the passengers, and either underlet the steerage to associations of emigrants or parcelled it out to sub-agents or to single passengers. These agents crowded emigrants into vessels without regard to their comfort or health, and there was no authority to which the latter could appeal for protection. As late as 1819 the lower deck of an emigrant vessel was no better than that of a slave or coolie ship. The ordinary height of the steerage deck was from 4 to 5 ft.; the lower, or orlop deck, which was also used for the transportation of passengers, was still worse. The natural consequence was a mortality frequently amounting to 10 and sometimes to 20 per cent. The first law which prescribed the space to be allotted to each steerage passenger was that passed by congress in March, 1819, which made it unlawful for a ship to carry more than two passengers for every five tons, custom-house measure. This law, however, did little toward reducing the hardships of the voyage, which was attended with much sickness and many deaths, the prevailing diseases being typhus or ship fever, cholera, and smallpox. In 1855 an act was passed by congress intended to secure\* the rights of emigrants on shipboard, by giving to each of them two tons of space, and providing for the proper ventilation of the ship, as well as for a sufficient amount of proper food; and this law has resulted in great amelioration. Another circumstance which has largely reduced the suffering and mortality during the voyage is the use of steamers instead of sailing vessels. In 1856 only about 3 per cent. of the emigrants came in steamers, while in 1873 more than 96 per cent. arrived in steamers and less than 4 per cent. in sailing vessels. The deaths in steamers were about 1 in 1,128 passengers, while the death rate in sailing vessels reached the significant ratio of 1 in 65. The port of New York is the great gate through which the emigration to the United States chiefly passes. Of the total number (437,004) of emigrants

in 1873, 266,818 entered at New York. Here exists the only thoroughly organized system in the country for their reception and protection. The extortions and frauds which had been practised upon emigrants arriving at New York, as well as the rapidly increasing tide of immigration, led to the passage by the legislature of the act of May 5, 1847, creating the board of commissioners of emigration of the state of New York, which has since been in successful operation. It consists of nine members, six of whom are appointed by the governor of the state with the consent of the senate, and three are members *ex officio*, viz.: the mayor of New York, the president of the German society, and the president of the Irish emigrant society. All the commissioners serve without compensation. Their duties are to protect alien passengers arriving at New York from fraud and imposition, to care and provide for the helpless among them, to give them trustworthy advice and information, and generally to guard their interests. To provide a fund for this purpose, the owner or consignee of any vessel carrying emigrants to New York is required to give a bond, with a penalty of \$300 for each alien passenger, to indemnify the commissioners and the state from any cost that may be incurred for the relief, support, or medical care of the person named in the bond during five years. In lieu of this bond he may pay a commutation, originally fixed at \$2 50, but in 1871 reduced to \$1 50, for each alien passenger brought into the port. For the more effectual protection of emigrants arriving at New York, an act was passed by the legislature in 1868, by which the commissioners of emigration are invested with authority to examine under oath any witness as to the condition of any ship, and the treatment of the emigrants while on board. The commissioners may also take testimony in reference to any death that may have occurred during the voyage; and such testimony, if made in the presence of the persons complained of, may be used as evidence in any subsequent action. The good intentions of the legislature, however, have not been realized, as the emigrants cannot afford the necessary time and money to enter into a long litigation against rich and powerful companies. The commissioners of emigration have therefore repeatedly and strongly urged congress to negotiate with foreign governments for the appointment of a joint high commission or court for the speedy adjudication of all cases relating to the treatment of emigrants while on board of a ship. Upon the arrival of an emigrant vessel at quarantine, six miles below the city, it is inspected by the health officer of the port, and the sick emigrants, if any, are transferred by steamer to hospitals, where they are cared for by the commissioners of emigration. If removed by authority of the health officers, they are taken to the quarantine hospital, where they are under charge of the quarantine commission. The vessel is then taken in charge by an officer

of the department who ascertains the number of passengers, the deaths, if any, during the voyage, and the amount and character of the sickness; he also examines the condition of the vessel in respect to cleanliness, and hears complaints by passengers; of all which he makes reports to the superintendent at Castle Garden. He remains on board the ship during the passage up the bay, to see that the passengers are not interfered with by any unauthorized person from the shore. After examination of their luggage by the customs officers the emigrants are transferred to the landing depot at Castle Garden, which was formerly a fortress defending the port, and was subsequently used as a place of amusement. It was opened as the emigrant landing depot in August, 1855, and is well adapted for the purpose. The emigrants are brought by barge or tug from the vessel in which they arrived, and after examination by a medical officer are ushered into the rotunda, a circular space comprising 50,000 sq. ft., and with a dome in the centre about 75 ft. high. It is well warmed, lighted, and ventilated, and will properly accommodate about 4,000 persons. Here the name, nationality, former place of residence, and intended destination of each individual, with other particulars, are registered. The newly arrived emigrant here finds facilities for supplying every immediate want without leaving the depot. The names of such as have money, letters, or friends awaiting them are called out, and they are put into immediate possession of their property or committed to their friends, whose credentials have first been properly scrutinized. There are clerks at hand to write letters for them in any European language, and a telegraph operator to forward despatches. Here, also, the main trunk lines of railway have offices, at which the emigrant can buy tickets, and have his luggage weighed and checked; brokers are admitted, under restrictions which make fraud impossible, to exchange the foreign coin or paper of emigrants; a restaurant supplies them with plain food at moderate prices; a physician is in attendance for the sick, and a temporary hospital ready to receive them until they can be sent to Ward's island; employment is provided by the labor bureau, connected with the establishment, to those in search of it; such as desire to start at once for their destination are sent to the railway or steamboat; while any who choose to remain in the city are referred to boarding-house keepers admitted to the landing depot, whose charges are regulated under special license, and whose houses are kept under supervision by the commission. Ample facilities for the care of sick and destitute emigrants are afforded by the institutions on Ward's Island, which are under the supervision of the commissioners of emigration. This island comprises about 200 acres in the East river, and extends opposite the city from 100th to 116th street; 121 acres, including the entire water front next to New York, are used for em-

igrant purposes, and the remaining portion is chiefly used by the commissioners of public charities and correction. The institutions embrace the hospitals, the refuge, the lunatic asylum, the nursery, dispensary, chapels, schools, workshops, &c. These institutions contain on an average about 2,000 inmates, the most of whom are more or less helpless. The chief building is the Verplanck hospital, which consists of a corridor 450 ft. long and two stories high, from which project five wings each 130 ft. long, 25 ft. wide, and two stories high except the centre wing, which has three stories; the corners of each wing are flanked with towers. It is constructed upon the most approved plans for perfect ventilation, and all necessary comforts for the sick. It has accommodations for about 500 patients, and is used exclusively for non-contagious diseases and surgical cases. A new lunatic asylum has recently been erected, with accommodations for more than 300 patients. The extent of the work done by the commission since its organization is indicated by the fact that of the 5,033,392 emigrants arriving at New York from May 5, 1847, to Jan. 1, 1873, for whom commutation money was paid, and all of whom received protection, advice, and information from the commissioners, 1,465,579 were provided and cared for out of the emigrant fund for a greater or less period during the five years subsequent to arrival, viz.: 398,643 received treatment and care in the institutions of the commissioners; 449,275 were supplied temporarily with board and lodging and money relief in the city of New York; 349,936 were provided with employment through the labor bureau at Castle Garden; 53,083 were forwarded from Castle Garden to their destination in the United States, or returned to Europe at their own request; and 214,642 were relieved and provided for in various parts of the state of New York at the expense of the commissioners of emigration. During 1873, 731 emigrant vessels from 23 different ports arrived at Castle Garden. In the labor bureau employment was procured for 25,325, including 7,504 females. Through the agency of the information bureau, about 12 per cent. of the total arrivals were delivered to their friends. The number cared for in the institutions on Ward's island was 12,586, including 2,134 receiving treatment at the beginning of the year; of this number 10,430 were discharged during the year, and 439 died, leaving 1,717 under treatment Jan. 1, 1874. The expenditures for the year amounted to \$466,108, including \$215,066 for support of the institutions on Ward's island, \$133,451 for expenses at Castle Garden, and \$61,188 for buildings and permanent improvements. The current expenses of the commission were \$510,306 in 1869, \$540,467 in 1870, \$518,387 in 1871, and \$461,028 in 1872. In addition to these sums, \$651,980 were expended during these four years in the erection of buildings and permanent improvements. These expendi-

tures are met by the funds realized from the commutation fund paid by owners or consignees of emigrant ships, which amounted to \$657,072 in 1869, \$534,056 in 1870, \$372,528 in 1871, \$442,429 in 1872, and \$402,199 in 1873. The emigrants are not considered or treated as paupers, but as persons requiring temporary aid and protection, for which neither the state nor any community is required to contribute. In 1872-'3 bills were introduced into congress to supersede the New York commission of emigration by a national bureau, thus vesting in the general government all control and regulation of this important subject; but the measures met with great opposition from the New York commissioners of emigration and others, and failed.—Prior to 1819 no official record was kept of the number and character of the persons coming to the United States from

abroad. The extent of the immigration prior to that date has been differently estimated by various authorities. Mr. Lorin Blodget thought the arrivals did not exceed 4,000 a year from 1789 to 1794. Dr. Adam Seybert estimated the number at 6,000 a year from 1790 to 1810. According to Prof. Tucker, whose estimate is confirmed by high authorities, 50,000 arrived from 1790 to 1800, 70,000 from 1800 to 1810, and 114,000 from 1810 to 1820; making 234,000 from 1790 to 1820. According to Mr. Young, chief of the United States bureau of statistics, the total number of arrivals prior to 1820 was 250,000, of whom 25,000 came between 1776 and 1790. In the following table are indicated the total number of alien passengers arriving in the United States in each year since 1820, and the chief countries from which they emigrated:

YEARS.	England.	Ireland.	Scotland.	Total British Isles.	British America.	Germany.	Prussia.	Holland.	Sweden and Norway.	France.	Switzerland.	Italy.	Total.
1820*	1,782	8,614	263	6,024	209	948	20	49	8	871	81	25	8,857
1821*	3,073	1,518	238	4,723	154	865	18	56	12	870	98	62	9,125
1822*	856	2,267	198	3,438	204	189	9	51	10	851	110	82	6,911
1823*	851	1,903	180	3,003	167	179	4	19	1	460	47	82	6,354
1824*	718	2,345	257	3,000	155	224	6	40	9	877	253	41	7,912
1825*	1,002	4,888	118	6,983	314	445	2	87	4	515	166	58	10,199
1826*	1,459	5,403	230	7,727	223	405	16	176	16	545	245	50	10,887
1827*	2,521	9,766	400	13,952	165	425	7	245	13	1,280	297	85	13,875
1828*	2,785	12,483	1,041	17,540	267	1,806	45	263	10	2,943	1,592	80	27,882
1829*	2,149	7,415	111	10,574	409	582	15	169	13	582	814	16	22,520
1830*	738	2,721	29	3,874	159	1,972	4	22	3	1,174	109	8	23,822
1831*	251	5,772	226	8,247	176	2,395	18	175	13	2,088	68	28	22,633
1832†	944	12,486	158	17,767	603	10,168	26	205	818	5,861	129	2	60,482
1833†	2,966	8,643	1,921	13,564	1,194	6,823	165	89	16	4,682	634	1,608	58,640
1834†	1,129	24,474	110	34,964	1,020	17,654	82	87	42	2,989	1,839	103	65,655
1835†	463	20,927	63	29,897	1,193	8,245	66	124	81	2,696	543	56	43,374
1836†	420	30,573	106	43,634	2,814	20,183	563	301	57	4,443	445	107	76,242
1837†	836	28,808	14	40,726	1,270	28,086	704	812	230	5,074	883	86	79,340
1838†	157	12,645	43	18,055	1,476	11,869	314	27	60	3,675	123	82	83,914
1839†	62	28,963	.....	34,233	1,226	19,794	1,284	85	324	7,198	607	76	65,069
1840†	318	29,430	21	42,043	1,938	28,881	1,123	57	55	7,419	500	28	84,066
1841†	147	87,772	85	58,960	1,816	13,727	1,534	214	195	5,006	751	166	80,259
1842†	1,748	51,842	24	73,847	2,078	18,287	2,083	890	538	4,504	483	98	104,565
1843†	3,517	19,670	41	28,100	1,502	11,482	3,009	380	1,748	3,346	538	108	52,496
1844*	1,357	83,490	23	47,843	2,711	19,226	1,505	184	1,311	3,155	839	79	78,615
1845*	1,710	44,821	368	64,081	3,193	83,188	1,217	791	928	7,663	471	63	114,871
1846*	2,854	51,752	305	73,982	3,855	57,010	551	979	1,916	10,683	698	88	154,416
1847*	8,476	105,386	887	128,888	8,827	73,444	887	2,631	3,807	20,040	192	160	224,963
1848*	4,455	112,984	659	143,093	6,473	58,014	451	918	908	7,743	819	219	226,572
1849*	6,036	159,893	1,060	214,530	6,590	60,062	173	1,190	3,473	5,941	18	208	297,024
1850*	5,276	138,896	627	175,485	7,796	63,168	14	576	1,363	8,009	146	360	310,004
1850†	1,521	80,198	233	89,614	1,580	14,969	745	108	206	1,372	179	46	59,976
1851†	5,306	221,218	966	272,740	7,483	71,322	1,160	852	2,424	20,126	427	428	379,466
1852†	30,007	159,548	8,148	200,247	352	143,575	2,843	1,719	4,108	6,763	2,788	297	371,603
1853†	23,867	162,649	6,006	201,225	5,424	140,653	1,293	600	3,364	10,770	2,748	267	368,645
1854†	43,901	105,931	4,605	160,235	6,891	206,054	8,955	1,594	3,831	13,317	7,953	94	427,898
1855†	33,871	56,832	5,275	97,199	7,761	66,219	5,699	2,538	821	6,044	4,438	1,024	200,877
1856†	25,904	59,008	3,297	29,007	6,498	69,877	7,221	1,395	1,157	7,246	1,780	962	200,896
1857†	27,804	70,211	4,132	112,840	5,670	83,798	7,988	1,775	1,712	2,397	2,086	632	251,806
1858†	14,638	84,410	1,946	55,829	4,603	42,291	3,019	185	2,430	8,155	1,050	889	128,126
1859†	18,826	49,709	2,298	61,879	4,163	39,315	2,463	290	1,091	2,579	833	764	121,282
1860†	13,001	60,692	1,618	73,874	4,514	50,746	3,745	351	298	8,971	118	770	153,640
1861†	8,970	83,274	767	43,472	2,039	80,189	1,472	283	616	2,326	1,007	764	91,920
1862†	10,947	85,359	637	47,990	3,275	24,945	2,544	492	892	3,142	643	541	91,987
1863†	24,065	96,088	1,940	122,739	3,464	31,939	1,173	416	1,627	1,838	690	557	176,252
1864†	26,096	89,442	3,476	116,951	3,636	54,379	2,897	708	2,249	8,128	1,896	597	193,416
1865†	15,083	77,870	3,087	112,287	21,566	80,797	2,627	779	6,109	8,583	2,839	928	249,061
1866†	2,770	83,894	672	131,620	32,150	110,440	5,432	1,716	12,683	8,585	8,823	1,298	318,494
1867†	.....	108,857	.....	125,520	6,014	121,240	12,186	2,223	7,055	5,287	4,168	1,612	298,358
1868†	11,107	50,857	1,949	107,652	10,894	111,508	11,567	652	20,420	8,936	3,261	1,402	297,215
1869†	55,046	79,080	12,415	147,716	30,921	124,776	22	1,860	41,888	4,118	3,488	2,182	306,922
1870†	59,483	75,544	11,820	151,089	53,840	91,163	611	970	24,365	8,556	2,474	2,940	373,796
1871†	61,174	61,468	12,185	143,934	39,929	107,201	.....	1,122	22,966	6,780	2,824	2,927	367,739
1872†	72,810	69,761	14,565	157,905	40,288	155,595	.....	2,006	24,992	13,752	4,081	7,239	449,458
1873†	69,600	75,848	18,003	159,355	29,508	183,141	.....	4,640	29,458	10,813	8,223	7,478	487,004
Total.....	719,776	2,907,865	124,381	4,319,048	894,216	2,603,437	100,953	88,886	281,344	276,187	71,650	41,626	8,803,141

\* Years ended Sept. 30. † 1882 and last quarter of 1831. ‡ Years ended Dec. 31. § First three quarters. ¶ Last quarter.

To obtain the net immigration from the preceding table, about 1 $\frac{2}{3}$  per cent. of the total aliens should be deducted for those not intending to remain in the United States. Those who died during the voyage are included prior to 1867. Prior to 1871 the statements for Germany do not include the emigrants from Prussia and Austria. Since 1819 a law of congress has required that all who come to the sea and lake ports shall be registered at the custom houses. The number, age, sex, nativity, occupation, and destination of all passengers coming to the United States, distinguishing aliens from citizens returning from abroad, and those intending to remain from those who come merely for temporary purposes, are ascertained and reported to the general government. This information is compiled and published annually by the United States bureau of statistics. No official registration is made, however, of those foreigners who enter the country through other channels than the sea and lake ports, many of whom come across the border from Canada and New Brunswick. The following statement shows the principal countries represented in the emigration to the United States from 1820 to 1874, with the total number from each during that period and in 1873:

FROM	1873.	1820 to 1874.
Great Britain and Ireland .....	159,355	4,819,048
Germany (including Prussia).....	183,141	2,764,420
Austro-Hungary.....	7,885	28,742
Sweden and Norway.....	29,453	231,844
Denmark.....	5,095	84,624
Netherlands.....	4,640	38,886
Belgium.....	1,306	19,716
Switzerland.....	3,223	71,650
France.....	10,813	276,187
Spain.....	456	24,876
Portugal.....	84	5,153
Italy, Sicily, Sardinia, and Malta.....	7,511	44,684
Greece.....	87	2,638
Turkey.....	78	440
Russia, Poland, and Finland.....	6,466	20,398
Other parts of Europe.....	9	33
<b>Total Europe.....</b>	<b>369,437</b>	<b>7,880,469</b>
Azores.....	1,397	10,187
Other islands of the Atlantic.....	81	1,060
West India islands.....	1,974	54,692
British North America.....	29,503	894,216
Mexico.....	473	21,722
Central America.....	84	1,253
South America.....	108	8,045
China.....	18,154	144,328
Japan.....	25	324
Other countries of Asia.....	40	866
Africa.....	13	736
Australasia, Pacific, and East India islands.....	1,052	4,794
Countries not specified*.....	14,460	255,721
Born at sea.....	133	862
<b>Total other countries than Europe and countries not stated.....</b>	<b>67,517</b>	<b>927,672</b>
Aggregate alien passengers.....	437,004	8,808,141
Estimated arrivals prior to 1820.....	.....	250,000
<b>Grand aggregate.....</b>	<b>.....</b>	<b>9,058,141</b>

The distribution of sex and age among those arriving for a series of years has been:

\* Includes aliens not intending to remain in the United States.

SEX AND AGE.	1870.	1871.	1872.	1873.
Number of passengers arrived:				
Male.....	255,540	247,756	299,746	297,162
Female.....	164,458	167,399	199,077	186,237
Total.....	419,998	415,155	498,823	483,409
Citizens of the U. S. returning:				
Male.....	26,271	30,188	32,737	30,297
Female.....	14,931	17,228	16,603	16,158
Total.....	41,202	47,366	49,340	46,455
Foreigners visiting the U. S.:				
Male.....	14,384	12,800	8,440	10,465
Female.....	8,109	7,961	3,213	3,994
Total.....	22,493	20,851	11,733	14,459
Net immigration under 15 years:				
Male.....	42,666	38,665	40,757	47,915
Female.....	38,621	35,378	49,063	44,444
Total.....	81,307	74,043	98,820	92,359
Net immigration, 15 to 40 years:				
Male.....	146,662	140,081	173,025	109,473
Female.....	84,966	88,252	104,911	98,347
Total.....	231,628	228,333	277,939	207,820
Net immigration over 40 years:				
Male.....	25,537	25,982	35,754	39,012
Female.....	17,831	18,580	25,237	28,854
Total.....	43,368	44,562	60,991	67,866
Total net immigration:				
Male.....	214,885	204,728	258,569	256,400
Female.....	141,418	142,210	179,181	166,145
Total.....	356,303	346,938	437,750	422,545

The number of foreigners in the United States in 1870, with the places of their birth, is reported as follows in the census of 1870:

Aggregate population.....	38,558,371	Lübeck.....	279
Born in the United States.....	32,991,142	Mecklenburg.....	89,670
Born in foreign countries.....	5,567,229	Nassau.....	8,962
White.....	5,493,712	Oldenburg.....	10,266
Colored.....	9,645	Prussia.....	596,782
Chinese.....	62,736	Saxony.....	45,256
Indian.....	1,136	Weimar.....	1,628
Not stated.....	954	Württemberg.....	127,919
Africa.....	2,657	Not specified.....	253,632
Asia.....	664	Gibraltar.....	77
Atlantic islands.....	4,431	Great Britain and Ireland (total).....	2,626,242
Australasia.....	3,118	England.....	550,924
Austria (proper).....	30,508	Ireland.....	1,855,827
Belgium.....	12,553	Scotland.....	140,835
Bohemia.....	40,289	Wales.....	74,533
British America (total).....	453,464	Not specified.....	4,123
Canada.....	414,912	Greece.....	390
New Brunswick.....	26,737	Greenland.....	3
Newfoundland.....	3,423	Holland.....	46,802
Nova Scotia.....	33,562	Hungary.....	3,787
Prince Edward Island.....	1,861	India.....	586
Not specified.....	18,469	Italy.....	17,157
Central America.....	801	Japan.....	73
China.....	63,042	Luxemburg.....	5,892
Cuba.....	5,819	Malta.....	15
Denmark.....	30,107	Mexico.....	42,455
Europe (not specified).....	1,546	Norway.....	114,246
France.....	116,402	Pacific islands.....	326
Germany (total).....	1,690,533	Poland.....	14,436
Baden.....	153,366	Portugal.....	4,542
Bavaria.....	204,119	Russia.....	4,644
Hamburg.....	7,829	Sandwich islands.....	684
Hanover.....	104,965	South America.....	3,555
Hesse.....	131,524	Spain.....	8,764
		Sweden.....	97,332
		Switzerland.....	75,158
		Turkey.....	802
		West Indies.....	6,250
		Born at sea.....	2,638

According to Mr. Young, 46 per cent. of the whole immigration, after deducting the women and children, had been trained to various pursuits, nearly half being skilled laborers and workmen. Nearly 10 per cent. consist of merchants and traders. The occupations of the

emigrants arriving in the United States from 1820 to Jan. 1, 1874, are shown in the following table, compiled by the United States bureau of statistics:

OCCUPATIONS.	1820-'30.	1831-'40.	1841-'50.	1851-'60.	1861-'73.	Aggregate.
Laborers	10,280	53,169	251,229	527,639	785,464	1,657,781
Farmers	15,005	88,240	256,350	404,712	318,434	1,083,271
Mechanics, not specified	6,805	56,582	164,411	179,726	176,113	583,637
Merchants	19,434	41,881	46,388	124,149	113,870	845,722
Servants	1,327	2,571	24,538	21,058	180,840	179,834
Miners	341	863	1,735	37,523	70,960	110,927
Mariners	4,995	8,004	6,398	10,087	23,624	53,108
Clerks	582	1,143	1,065	792	22,197	23,979
Weavers and spinners	2,937	6,000	1,308	717	6,945	18,502
Physicians	805	1,959	2,116	2,229	3,766	10,875
Seamstresses, dressmakers, and milliners	413	1,072	2,096	1,065	5,737	11,033
Clergymen	415	932	1,559	1,420	4,118	8,444
Bakers	583	569	28	92	10,247	11,519
Artists	139	513	1,223	615	3,951	6,441
Butchers	329	432	76	103	8,505	9,750
Tailors	953	2,252	65	834	10,871	14,505
Shoemakers	1,109	1,966	63	836	10,660	14,134
Manufacturers	175	107	1,533	1,005	1,917	6,037
Lawyers	244	461	831	1,140	1,861	4,537
Masons	793	1,435	24	58	15,235	17,545
Engineers	226	811	654	825	4,001	6,017
Teachers	275	267	832	154	3,096	4,624
Millers	199	189	88	210	2,286	2,917
Painters	232	369	8	33	4,056	4,703
Printers	179	472	14	40	1,395	2,100
Musicians	140	165	236	183	2,079	2,808
Actors	183	87	233	65	403	991
Hatters	137	114	1	4	85	641
Other occupations	5,466	4,004	2,892	13,884	67,842	94,048
Occupations not stated, and without occupation	101,442	363,252	969,411	1,544,494	2,395,612	5,624,211
Total	176,473	640,066	1,768,175	2,874,637	4,206,350	9,635,771
Deduct citizens of the United States	24,649	40,961	54,924	276,473	460,623	857,630
Aliens	151,824	599,125	1,713,251	2,598,214	3,745,727	8,808,141

In respect of nationality, more than half of those having arrived are British, coming from the United Kingdom of Great Britain and Ireland and the British possessions in North America, and speaking the English language. The German element is next in magnitude, and embraces nearly two thirds of the remainder. A large proportion settle in rural districts and develop the agricultural resources of the west and south, while the remainder, consisting largely of artisans and skilled workmen, find employment in the cities and manufacturing towns. About 25 per cent. of the emigrants are under 15 years of age, and less than 15 per cent. over 40, leaving more than 60 per cent. in the prime of life. The number of males is largely in excess of that of females, the ratio varying with the nationality. Among the Chinese only about 7 per cent. are females, while their ratio among the Irish is over 45 per cent., and in the total number of emigrants about 40 per cent.—For several centuries there has been a great emigration from China to the surrounding countries, both by sea and land. Vast multitudes of Chinese have settled in Tartary, Thibet, Anam, Siam, Burmah, Malacca, and in Borneo, Java, Sumatra, the Philippine islands, and in short everywhere in the East Indian archipelago. But of these emigrants there are no accurate statistics. Of late years they have made their way in considerable numbers to Australia; and in 1853, attracted by the gold of California, they began to come to the United States, and their immigration has attained a magnitude worthy of at-

tention. The whole number who had arrived up to Jan. 1, 1874, was 144,328, nearly all of whom entered at San Francisco. Most of them have settled in California, where they are occupied chiefly in mining pursuits; but many have found their way to Nevada and some of the territories, and a few to the Atlantic and some of the other states. Nearly one half of all who have arrived have returned to their native country. According to the census of 1870, there were 63,199 Chinese in the United States, of whom only 4,566 were females; there were 49,277 in California, 4,274 in Idaho, 3,330 in Oregon, 3,152 in Nevada, and 1,949 in Montana. The number of arrivals, according to the United States bureau of statistics, is given below; those prior to 1855 are differently reported by another authority in the article CHINA:

YEARS.	No. of Im-migrants.	YEARS.	No. of im-migrants.
1853	42	1865	2,942
1854	13,100	1866	2,385
1855	3,526	1867	3,868
1856	4,733	1868	10,654
1857	5,944	1869	14,902
1858	5,123	1870	11,943
1859	3,457	1871	6,039
1860	5,467	1872	10,642
1861	7,518	1873	18,154
1862	3,633		
1863	7,214	Total	144,328
1864	2,795		

The Chinese emigration to the United States has been characterized by an organized system which is not found in the emigration from any European nation. The latter, as has been

seen, is entirely without system or organization, and the emigrant is wholly unrestrained as soon as he reaches his destination. The emigration from China, however, is controlled by men of large capital, who engage in it as a traffic. A contract is made with the emigrants in their native country by which they mortgage their future earnings to secure the cost of passage and other expenses, and which binds them to a specified term of service after arrival in this country. In many instances the Chinaman gives a mortgage on his wife and children, with a stipulation that at the end of his term of service he is to be brought back to China by his contractor. This contract is sold

or transferred to an agent in the United States at an advance, and is thus a source of great profit to the dealer. The agent contracts for the labor of the Chinese in any part of the United States. Perhaps the most prominent contractor of this kind has been Mr. Koopmanschap, who sought to introduce Chinese labor under this system into the southern states and other parts of the United States. The contract made in China has no validity in the United States, but it has always been strictly observed by both parties. The following table, from the census of 1870, exhibits the distribution by states and territories of the leading nationalities in the United States:

STATES AND TERRITORIES.	Aggregate population.	Total foreign.	British America.	England.	Ireland.	Scotland.	Wales.	France.	Germany.	Holland.	Switzerland.	Norway and Sweden.
Total of the U'd States.	88,555,988	5,366,546	498,464	550,924	1,555,779	140,885	74,538	116,402	1,690,588	46,802	75,158	211,578
Total of the states....	88,118,258	5,472,346	457,605	528,990	1,898,678	136,846	71,907	115,040	1,679,146	46,501	73,972	206,568
Alabama .....	996,992	9,962	183	1,041	3,878	458	39	594	2,482	14	168	126
Arkansas .....	484,471	5,026	842	526	1,428	156	24	587	1,568	71	104	154
California .....	560,247	209,581	10,660	17,699	54,421	4,449	1,517	8,068	29,701	452	2,927	2,944
Connecticut .....	587,544	118,639	10,561	18,001	70,080	3,288	258	1,211	12,448	59	492	805
Delaware .....	125,015	9,166	112	1,421	5,907	229	48	127	1,142	16	33	9
Florida .....	157,748	4,967	174	399	787	144	6	126	597	7	14	46
Georgia .....	1,184,109	11,127	247	1,088	5,068	420	61	312	2,761	42	103	49
Illinois .....	2,539,891	515,198	82,550	58,871	120,162	15,737	3,146	10,911	203,758	4,180	8,180	41,659
Indiana .....	1,630,687	141,474	4,765	9,945	28,698	2,507	556	6,363	78,060	573	4,287	3,803
Iowa .....	1,191,792	204,057	17,905	16,660	40,124	5,248	1,667	3,180	66,162	4,513	3,987	28,352
Kansas .....	864,399	48,392	5,324	6,161	10,540	1,531	1,021	1,274	12,775	300	1,322	5,542
Kentucky .....	1,321,011	68,398	1,082	2,511	21,642	1,019	347	2,057	80,818	270	1,147	128
Louisiana .....	726,915	61,827	712	2,797	17,068	814	114	12,841	18,923	232	573	434
Maine .....	626,915	48,881	26,788	3,650	15,745	1,998	279	187	506	26	9	149
Maryland .....	750,894	88,412	644	4,868	23,650	2,432	194	649	47,045	236	207	118
Massachusetts .....	1,457,351	353,319	70,055	34,085	216,120	9,003	576	1,629	13,072	480	491	21,603
Michigan .....	1,184,059	268,010	83,580	35,047	42,018	8,552	568	3,121	64,148	12,559	2,116	3,922
Minnesota .....	439,706	160,697	16,688	5,672	21,746	2,194	944	1,743	41,364	1,555	2,162	56,927
Mississippi .....	827,922	11,191	375	1,051	3,859	434	25	630	2,960	38	266	1,048
Missouri .....	1,721,295	222,267	8,448	14,314	54,983	3,238	1,524	6,298	113,618	1,167	6,597	2,599
Nebraska .....	122,993	30,748	2,685	3,602	4,999	792	220	340	10,974	160	563	2,538
Nevada .....	42,491	18,801	2,865	2,547	5,085	380	301	414	2,181	44	247	297
New Hampshire .....	318,800	29,611	12,955	2,637	12,190	892	27	60	436	5	11	97
New Jersey .....	906,096	18,943	2,474	26,674	56,784	5,710	804	3,130	84,001	2,844	2,061	644
New York .....	4,852,759	1,189,253	79,042	110,003	528,806	27,282	7,837	22,302	316,902	6,426	7,916	6,497
North Carolina .....	1,071,361	8,029	171	500	677	420	10	54	904	13	60	40
Ohio .....	2,665,260	872,439	12,988	36,538	82,674	7,819	12,939	12,781	182,997	2,015	12,727	316
Oregon .....	90,223	11,600	1,187	1,344	1,967	394	63	308	1,875	39	160	281
Pennsylvania .....	3,521,791	545,261	10,022	69,668	285,750	16,846	27,638	8,695	160,146	819	5,775	2,381
Rhode Island .....	217,353	55,396	10,242	9,285	31,534	1,948	56	167	1,201	45	74	123
South Carolina .....	705,606	8,074	77	616	3,262	310	15	143	2,754	82	45	61
Tennessee .....	1,263,520	19,816	587	2,085	8,048	875	814	1,662	4,589	100	502	856
Texas .....	818,579	62,411	597	2,087	4,081	621	85	2,232	23,976	54	599	767
Vermont .....	380,551	47,153	28,544	1,946	14,080	1,240	565	98	870	20	19	117
Virginia .....	1,225,163	13,754	327	1,909	5,191	705	148	369	4,050	231	148	47
West Virginia .....	442,014	17,091	207	1,811	6,332	746	321	223	6,282	174	325	6
Wisconsin .....	1,054,670	364,499	25,664	28,192	48,479	6,500	6,550	2,704	162,314	5,900	6,069	42,845
Total of the territories.	442,730	94,200	5,859	21,924	17,101	3,989	2,626	1,262	11,387	241	1,181	5,015
Arizona .....	9,668	5,809	142	184	495	54	8	69	379	11	23	14
Colorado .....	39,864	6,599	753	1,858	1,685	188	165	209	1,456	17	140	220
Dakota .....	14,181	4,815	906	248	888	77	8	57	565	8	33	1,559
District of Columbia .....	131,700	16,254	290	1,422	8,218	352	29	238	4,018	83	175	27
Idaho .....	14,999	7,555	384	540	966	114	335	144	59	9	52	152
Montana .....	20,595	7,979	1,172	692	1,635	208	197	198	1,238	18	97	229
New Mexico .....	91,874	5,620	125	120	543	36	9	124	552	3	42	11
Utah .....	56,786	30,702	657	16,073	502	2,391	1,788	63	885	122	609	2,408
Washington .....	23,955	5,024	1,121	791	1,047	309	44	113	645	25	50	262
Wyoming .....	9,118	3,513	329	556	1,102	260	58	57	652	5	60	137

—The variance in the magnitude of the emigration to the United States in different periods presents results of great interest and importance, and points to the causes that increase or diminish the movement from foreign countries.

Chief among these causes are war, political troubles, famine, commercial panics, and other influences which produce distress at home or an unfavorable condition of affairs in the country to which emigration is directed. The most



remarkable illustrations of this kind were presented by the great exodus from Ireland and that from Germany during the period 1845 to 1854, when the highest figures till then known in the history of emigration were reached. After the great famine of 1846, the emigration from Ireland to the United States, which had increased from 44,821 in 1845 to 51,752 in 1846, rapidly rose to 105,536 in 1847, 112,934 in 1848, 159,398 in 1849, and 164,004 in 1850. It reached its maximum in 1851, when 221,213 Irish emigrants arrived in the United States; and in the following year it decreased to 159,548. During the period from 1845 to 1854 inclusive, 1,512,100 Irish left their country for the United States, of whom 607,241 came during the first and 904,859 during the last half of the decade. Since 1854 the movement has fallen off to less than one half of the average of the preceding ten years. During this same period the emigration from Germany also culminated. This increase was very marked as early as 1845, when the number of German emigrants was 33,138; in 1847 it reached 73,444; in 1848, 58,014; in 1849, 60,062; and in 1850, 63,168. This disturbance in the ordinary tide of emigration has been attributed to the political revolutions attempted in 1848 and 1849. The increase continued till 1854, when the German emigrants reached the number of 206,054. In discussing the causes of this remarkable exodus Frederick Kapp, for many years a commissioner of emigration, says in his work on "Immigration": "The *coup d'état* of Louis Napoleon closed for all Europe the revolutionary era opened in 1848. In the three years preceding that event, the issue of the struggle of the people against political oppression had remained doubtful. But the second of December, 1851, having decided the success of the oppressors for a long time to come, the majority of those who felt dissatisfied with the reactionary *régime* left their homes. The fact that the largest number of Germans ever landed in one year in the United States came in 1854, showed the complete darkening of the political horizon at that time. The apprehension of a new continental war, which actually broke out a year later in the Crimea, also hastened the steps of those who sought refuge in this country. People of the well-to-do classes, who had months and years to wait before they could sell their property, helped to swell the tide to its extraordinary proportions." From the beginning of 1845 to the close of 1854 the number of Germans arriving in the United States was 1,226,392, of whom 452,943 came in the first and 773,449 in the last five years. In 1866 and 1867 the tide of German emigration again began to swell, "in consequence," according to Mr. Kapp, "of the emigration of men liable to military service from the new provinces annexed to Prussia in 1866, and of families dissatisfied with the new order of things." In 1872 it reached the unprecedented magnitude, except in 1854, of 155,595.

The extent of the emigration to the United States, however, is not governed by political events, failure of crops, commercial and industrial crises, &c., acting in Europe alone, but also by the same causes operating in this country. The effects of the great financial crisis of 1837 are indicated in the falling off of the total immigration from 79,340 in that year to 38,914 in the following. And so the commercial crisis of 1857 was followed in the two ensuing years by a smaller immigration than that of any year since 1845; while during the first two years of the civil war (1861 and 1862), the number of aliens arriving was less than that of any year since 1844. Since the close of the war there has been a marked increase. The arrivals amounted to 449,483 in 1872, being more than in any preceding year, and 437,004 in 1873. The northern and western states, chiefly the latter, have been the chosen destination of the great majority of emigrants to the United States. Prior to the civil war there was very little emigration to those states in which slavery existed, except Missouri. Since the war great efforts have been made by the southern and southwestern states to encourage emigrants to settle there, but with only partial success as yet. In many of these states bureaus of emigration have been established or commissioners appointed, for the purpose of preparing reports showing the inducements offered to emigrants. This information is published in various languages and gratuitously distributed in the United States and in Europe. The United States bureau of statistics also publishes information for emigrants relative to the demand and compensation for labor in the several states, the cost of living, the price and rent of land, staple products, market facilities, the cost of farm stock, and such other practical information as the emigrant most needs.—The contribution made by emigration to the population and wealth of the United States has been in the highest degree valuable and important. Its extent, however, is determined only by computation, and different authorities have reached different results. According to Mr. Kapp, who followed the estimate of Mr. Schade that the natural rate of increase in the native population of the United States, exclusive of slaves, had been 1.38 per cent., that population, including white and free colored, would have been 8,435,882 in 1860, and 9,675,041 in 1870; whereas the total white and free colored population, including the foreign element, was 27,489,662 in 1860, while the white population alone in 1870 was 33,589,377. According to this calculation, more than 24,000,000 of the population in 1870 was of foreign extraction. Dr. Jarvis, however, has shown that this proportion is entirely too great, owing in part to the fact that the census reports of the number of births and deaths on which the calculation is based are erroneous. According to the federal census, the number of foreign-born living in the

United States was 2,244,602 in 1850, 4,138,697 in 1860, and 5,567,229 in 1870. In the last named year statistics concerning the nativity of parents were collected for the first time, and show that there were 10,892,015 persons having one or both parents foreign, 10,521,233 a foreign father, 10,105,627 a foreign mother, and 9,734,845 both parents foreign. There were therefore 1,157,170 persons of mixed (half American and half foreign) parentage. In measuring the increase of the foreign element, Dr. Jarvis assumes that only one half (578,585) of this number should be added. Deducting this from the census statement, 10,313,430 remain as the surviving number of foreigners and their children of the first generation, as reported by the census of 1870. This, however, does not include the children of the second and third generations, the number of whom Dr. Jarvis determines at 400,000, making the total foreign element in 1870, 10,813,430; American, 22,775,947; aggregate white population, 33,589,377. The census reports the total number of surviving foreigners in 1870 and the total of their children born in the United States of entire and half foreign parentage, but gives no indication of the nationality or race of these children. The distribution of the entire foreign

element into the chief nationalities has been computed by Dr. Jarvis as follows:

NATIONALITY.	Born in foreign countries.	Their children born in U. S.	Total.
Irish.....	1,855,827	1,775,012	3,630,839
German.....	1,600,410	1,616,795	3,207,205
British.....	715,027	781,712	1,496,739
Scandinavian.....	268,791	228,892	497,683
All others.....	1,017,074	972,875	1,990,049
Aggregate.....	5,567,229	5,824,786	10,892,015

According to the report of the United States bureau of statistics, 9,058,141 aliens had arrived in the United States from the foundation of the government to Jan. 1, 1874, of whom 250,000 were estimated to have come prior to 1819. Deducting 1½ per cent. for those not intending to remain, the total number of aliens permanently added to the population to the close of 1873 was 8,907,172. Dr. Jarvis has determined the number of foreigners arriving and of those surviving in the United States at decennial periods since 1790. These results are exhibited in the following statement, and it will be seen that the variance is slight from the census returns of foreigners in 1850, 1860, and 1870:

EMIGRANTS ARRIVING IN DECENNIAL PERIODS AND SURVIVING AT THEIR CLOSE.

ARRIVED.		SURVIVING IN							
Period.	Number.	1800.	1810.	1820.	1830.	1840.	1850.	1860.	1870.
1760-1800.....	50,000	44,282	84,732	27,241	21,864	16,755	18,185	10,272	8,179
1800-1810.....	70,000	.....	61,993	43,623	88,137	29,912	23,796	18,237	14,600
1810-1820.....	114,000	.....	.....	100,561	79,157	62,100	49,409	37,868	30,815
1820-1830.....	500,000	.....	.....	.....	177,141	138,940	110,578	84,714	67,810
1830-1840.....	682,112	.....	.....	.....	.....	611,486	456,450	372,529	298,459
1840-1850.....	1,711,161	.....	.....	.....	.....	.....	1,552,709	1,110,066	952,685
1850-1860.....	2,766,435	.....	.....	.....	.....	.....	.....	2,421,944	1,988,742
1860-1870.....	2,424,350	.....	.....	.....	.....	.....	.....	.....	2,223,548
1790-1870.....	8,018,153	44,282	96,725	176,825	315,890	559,202	2,236,217	4,135,890	5,564,878
Census.....	.....	.....	.....	.....	.....	.....	2,244,602	4,138,697	5,567,229
Variance.....	.....	.....	.....	.....	.....	.....	8,865	2,807	2,851

In reaching the above results, the numbers of the survivors of those who arrived in each decade are calculated at the annual rate of 2.4 per cent. mortality and .976 per cent. surviving for the periods 1790 to 1850, 2.625 per cent. mortality for the period 1850 to 1860, and 2.2 per cent. mortality for the decade 1860 to 1870. This is a very high rate of mortality, especially when it is considered that among the emigrants are included only a small portion of those in the perilous periods of life, the very young and the aged, but that they are chiefly in the healthy ages, when the death rate is low. This, however, may be explained by the fact that they are mostly of the poor, whose death rate is everywhere greater than that of the comfortable classes; and that a large proportion of them are Irish, whose vitality is very low. It would be important to know the capital value of immigration to the United States, and the addition thus made to

the national wealth; but this result can only be reached by a computation which will be but approximately accurate. In 1856 the commissioners of emigration in New York examined every emigrant as to the amount of his means, and it was ascertained that the average cash of each of the 142,342 arriving that year was \$68 08. This amount, however, was thought to be much below the actual average, since it subsequently appeared that many emigrants, not understanding the object of this inquiry, were careful not to report the full amount of their means. Mr. Kapp estimated the average amount of money brought by each emigrant at \$100, and other personal property at \$50; total, \$150. This estimate, however, is believed by many to be far beyond the facts. Dr. Young estimates the average amount brought by each at \$80. Assuming that the 422,545 aliens who arrived in the United States in 1873 with the inten-

tion of remaining brought an average of \$80 each, it will be seen that the immigration of that year added \$33,803,600 to the wealth of the country. Applying the same calculation to the total number of aliens arriving with the intention of remaining from the formation of the government to the beginning of 1874, and the result is about \$712,000,000 as the total amount contributed by immigration to the wealth of the country since its origin. In the above computation only the money value of the emigrant is considered, but the economic value of each, arising from the addition to the industrial and intellectual resources of the country, is still greater. Mr. Kapp, taking the estimate of the distinguished German statistician, Dr. Engel of Berlin, that it costs 750 thalers to produce a manual laborer in Germany, and assuming that about double this amount is the cost of an unskilled laborer in America, calculates that the capital value of each male emigrant is \$1,500, and of each female \$750, making the average for every person of either sex \$1,125. Dr. Young, however, considers this estimate to be too high, and makes the average capital value of each immigrant \$800. At this rate the emigration to the United States in 1873 added about \$338,000,000 to the national wealth, while the increase from this source since the formation of the government is about \$7,125,700,000. The uncertainty of such computations, however, is made still greater by the fact that no allowance is made for unfortunates, paupers, and criminals, who are a charge to the community. These classes of foreigners in 1870 numbered nearly 50,000, as appears by the following statement from the census, showing the total of each class national and foreign in the United States :

CLASSES.	Aggregate.	Born in United States.	Born in Foreign Countries.
Blind.....	20,320	17,048	3,277
Deaf and dumb.....	16,205	14,869	1,336
Insane.....	37,352	26,161	11,221
Idiotic.....	24,527	22,582	1,645
Paupers receiving support June 1, 1870.....	76,737	53,939	22,798
Number of persons in prison June 1, 1870.....	32,901	24,173	8,728
Total.....	208,072	150,067	49,005

—The most extensive European emigration has been from Great Britain and Ireland. According to the report of the land and emigration commissioners, 7,561,285 persons emigrated from the United Kingdom between 1815 and 1873, the principal points of destination being the North American colonies, the United States, and the Australian colonies. The largest proportion of these have been from Ireland. Thus the official reports of the United States show that of the 4,319,048 immigrants from the British isles between 1820 and the beginning of 1874, 2,907,565 were from Ireland, 719,776 from England, and 124,331 from Scotland.

Prior to 1815 the emigration from the United Kingdom was unimportant. Up to 1835 the main stream was toward the North American colonies; but since that year the great body of British emigration has been to the United States. Including the foreign emigration passing through the country, which has been considerable since 1864, and constituted 26 per cent. in 1872, it has been :

YEARS.	To the North American Colonies.	To the United States.	To the Austral. Colonies and New Zealand.	To other places.	Total.
1815....	680	1,209	.....	192	2,081
1816....	3,370	9,022	.....	115	12,510
1817....	9,797	10,280	.....	557	20,634
1818....	15,136	12,429	.....	222	27,787
1819....	23,584	10,674	.....	579	34,757
1820....	17,921	6,745	.....	1,078	25,729
1821....	12,355	4,958	.....	384	18,297
1822....	16,018	4,187	.....	219	20,429
1823....	11,255	5,182	.....	163	16,550
1824....	8,874	5,152	.....	99	14,025
1825....	8,741	5,551	465	114	14,891
1826....	12,818	7,003	903	116	20,900
1827....	12,648	14,226	715	114	28,003
1828....	12,064	12,517	1,056	135	26,092
1829....	13,307	15,678	2,016	167	31,198
1830....	30,574	24,887	1,242	204	56,907
1831....	53,067	23,413	1,161	114	83,160
1832....	66,329	32,572	3,782	196	103,140
1833....	28,808	29,109	4,003	517	62,527
1834....	40,000	33,074	2,800	588	76,222
1835....	15,573	26,220	1,660	325	44,473
1836....	34,226	37,174	3,124	218	75,417
1837....	29,854	36,770	5,154	326	72,034
1838....	4,577	14,322	14,221	292	33,222
1839....	12,658	33,536	15,766	227	62,207
1840....	32,293	40,422	15,570	1,153	90,743
1841....	38,164	45,017	32,625	2,786	118,592
1842....	54,128	63,852	37,784	1,385	156,844
1843....	23,518	28,335	3,478	1,851	57,212
1844....	22,324	43,660	2,229	1,573	70,666
1845....	31,808	58,538	1,800	2,320	93,501
1846....	43,439	62,139	2,947	1,856	129,851
1847....	109,650	142,154	4,159	1,487	256,270
1848....	31,065	18,323	53,004	4,857	106,699
1849....	41,367	219,450	32,191	6,400	299,498
1850....	32,961	223,078	16,937	8,773	280,549
1851....	42,605	167,357	21,132	4,472	335,966
1852....	32,573	244,261	57,581	3,749	368,764
1853....	34,522	230,875	61,401	3,159	329,937
1854....	48,761	173,065	18,337	3,976	324,229
1855....	17,966	108,414	52,809	3,118	176,807
1856....	16,378	111,537	44,784	3,775	176,544
1857....	21,001	126,905	61,248	3,721	212,875
1858....	9,704	59,716	39,225	5,277	114,972
1859....	6,659	70,308	31,113	12,427	120,433
1860....	7,766	65,700	24,502	6,851	125,469
1861....	12,707	49,764	23,768	5,161	91,770
1862....	15,522	58,706	41,743	5,143	121,214
1863....	18,058	146,818	13,454	5,808	228,758
1864....	12,721	147,042	40,742	8,195	208,500
1865....	17,211	147,258	37,208	8,449	209,801
1866....	13,355	161,000	24,977	6,730	204,582
1867....	15,538	159,275	14,406	6,719	195,953
1868....	21,062	175,582	12,809	6,152	196,325
1869....	23,891	203,001	14,001	6,124	206,927
1870....	25,215	196,075	17,065	8,515	206,940
1871....	32,671	198,843	12,227	8,094	222,485
1872....	32,205	233,747	15,276	13,185	295,213
Agg'te.	1,456,647	4,905,262	1,016,926	182,150	7,561,285

Notwithstanding this great exodus, the population of the United Kingdom increased from 18,627,476 in 1811 to 31,817,108 in 1871. The increase has been steady and constant in England, Wales, and Scotland; but in Ireland there has been a remarkable decrease. In 1841 the population of Ireland was 8,175,124; and in

1851, owing chiefly to the great exodus following the famine of 1846, it had decreased to 6,551,970. In 1861 it was 5,792,055, and in 1871 5,402,759, or more than half a million (535,097) less than it was in 1811. In Great Britain protection is extended by the government to emigrants, especially those destined to the British possessions. Emigration is regulated to a considerable extent by the government, acting through the land and emigration commissioners. Acts have been passed at various times for regulating the number of passengers in each ship and providing for their proper accommodation on board, and for protecting them from the numerous frauds to which they are exposed. To enforce the provisions of these acts, and generally to protect the interests of emigrants, government agents are stationed at the principal ports of embarkation, and at the chief colonial ports to which emigration is directed.—The German emigration is chiefly to the United States, and its principal points of departure are the ports of Hamburg and Bremen. As early as 1819 efforts were made in Brazil to attract emigration from Germany and Switzerland, but the treatment of the emigrants by the large property holders prevented the success of the enterprise. In 1850 an act was passed offering great inducements to colonists, and the immigration of settlers from Europe, particularly Germans and Swiss, has been otherwise encouraged by the government. These efforts have been attended with but partial success, as only about 50,000 persons have settled in the empire, chiefly in the southern provinces. There has been an immigration of some importance during recent years into the Argentine Republic. This amounted for 14 years ending Jan. 1, 1871, to 204,451 persons, who were mostly from Italy, Spain, and France. In order to encourage immigration, the government of Buenos Ayres in 1873 offered a premium of \$50 each to the first 100,000 immigrants between the ages of 12 and 45, to be paid at the expiration of 18 months after arrival.—Formerly the doctrine was held by Great Britain and other European powers that a subject could not throw off his allegiance by emigrating therefrom; and whether he became a naturalized citizen of another country or not, his own still retained its claim upon him. Treaties, however, have been recently concluded between the United States and Great Britain, Sweden and Norway, Denmark, Belgium, the late North German Confederation, Austria, Hungary, Baden, Bavaria, Hesse-Darmstadt, Württemberg, and Mexico, which provide that subjects of these powers who have become naturalized citizens of the United States, and have resided uninterruptedly therein for five years, shall be held to be citizens thereof. The treaties with Belgium and Great Britain do not require a residence of five years within the United States, but recognize citizenship if sooner acquired. It seems to be the opinion of French jurists

that a French subject can at any time by his own act transfer his allegiance to any country which consents to naturalize him. He thus, according to the Code Napoléon, "loses the quality of a Frenchman." Italy, Spain, Norway, and Greece follow substantially the Code Napoléon, and treat nationality as lost by naturalization in a foreign country, or by entering without royal license into its civil or military service. A Russian subject cannot emigrate or become naturalized in a foreign country without the permission of the emperor; if he does so, he commits an offence for which he may be for ever excluded from the Russian dominions. Nor can a subject of the Ottoman empire divest himself of that character without the authority of the imperial government.

**EMINENT DOMAIN** (in the Roman law, *dominium eminentis*), the right of property possessed by a state, which is higher over all the goods and valuables within the state than that of any individual. *Dominus* and *magister* are both translated by the word "master;" but *dominus* means master by the right of property, while *magister* means master by the right of superiority. Hence *dominium* as a law term is quite accurately represented by the word property. The phrase eminent domain means, in practice, the right inherent in any sovereignty of taking possession of any valuable thing, be it real or personal, and using it for a public purpose. Where, in the theory of the law, all property is held by tenure from the sovereign, the exercise of this right may be regarded as only a resumption of that which it originally granted; and all property may be supposed to rest on a title to which the condition was annexed that it might be thus resumed by the original grantor. In this country, as in all other republics, the right of eminent domain rests on the paramount right of the public welfare. Whatever be its ground, it is entirely certain that the right of eminent domain, or the right to take private property for public use, is distinctly asserted and frequently exercised, both by the national government and by that of the several states. One condition is always affixed to it, viz., that the public good requires that private property should thus be taken for public use; and this fact must be ascertained under legislative authority. Another condition is annexed to the exercise of this power by the constitution of the United States, and by that of many states—a condition which is universal in practice, and would doubtless be held to be always implied in law; it is that adequate compensation be made to those from whom the property is taken. The most common instances of the exercise of this power are in the case of lands taken for roads or canals; but it is, we conceive, quite certain that the principle itself is wholly unlimited, and that by virtue of it any property may be taken by the sovereign power from any owner, provided it is required for public use, and compensation is made to the owner from whom the prop-

erty is taken. The taking need not be by the sovereignty itself, but, under legislative authority, may be by corporations or individuals empowered to construct works of public utility; and in several of the United States it has been decided that the construction of mills and manufactories is so far a matter of public concern as to justify the appropriation of private property under the eminent domain to obtain the requisite water power.

**EMIR**, or **Amir**, an Arabic title, meaning a prince or commander. The caliphs had the title of *emir al-mumenin*, commander of the faithful; and the Abbassides toward the latter part of their dynasty named their chief minister *emir al-omra*, prince of the princes. This official presided over the council and commanded the army. About 1588 Amurath III. appointed one of the Druse sheiks emir, with viceregal powers. In Persian *mir* is derived from *emir*, and hence *mirzadeh*, descendant of a prince, which has been corrupted to *mirza*.

**EMLYN, Thomas**, an English clergyman, born in Stamford, May 27, 1663, died July 30, 1743. He was educated at Cambridge, and settled in 1691 in Dublin, where he gained great reputation as a preacher. In 1697 he advanced doctrines at variance with those of his congregation, declaring the Father preëminent over the Son and Spirit, and thus reviving Arianism. The opposition which was excited against him obliged him to leave Ireland, and he published in England a "Vindication of the Worship of the Lord Jesus Christ on Unitarian Principles" (1706). This book brought upon him a prosecution for blasphemy, and he was fined and condemned to a year's imprisonment. He did not pay the fine, but remained in prison two years, and after his release preached to a congregation of his friends in London. Besides his theological works, he wrote "Memoirs of the Life and Sentiments of Dr. Samuel Clarke" (1731).

**EMMANUEL, Emanuel, or Immanuel**, a Hebrew word signifying "God with us." It is used by Isaiah in a prophecy which according to Matthew was accomplished in Jesus Christ, who is thus divinely recognized as the predicted Messiah, the true Immanuel, or "God with us."

**EMMENAGOGUES**, drugs used to promote the menstrual function. No drug has the power to do this directly and independently of the efforts of nature. Some medicines, such as aloes and other cathartics, produce a congestion in the neighborhood of the uterus which may be shared by this organ. Local warmth has a similar effect. Savin, tansy, rue, and to a less degree other aromatics, act as general stimulants, and under favorable circumstances assist the natural function. But tonics, and especially iron, are in many cases of much greater use than any of these. The local application of electricity is often of service. The name emmenagogue is in some classifications made to include ergot and other drugs which have no effect upon the secretions of the uterus. Certain emmenagogues are used as abortifacients, but for-

tunately are but little to be relied upon for this purpose. Ergot alone is inefficient as an abortifacient. Tansy and savin are not only dangerous, but frequently fail to produce abortion, even when they destroy the life of the mother. The root of the cotton plant (*gossypium*) has been much used in the southern states for the purpose of regulating and promoting the catamenial discharge, and when properly administered is not without value for this object. Whenever there is local disease of the ovaries or uterus, which disturbs and checks the menstrual function, the best emmenagogue is an appropriate local treatment.

**EMMERICH**, a town of Prussia, on the right bank of the Rhine, 5 m. N. E. of Cleves; pop. in 1871, 7,817. It is the nearest Prussian town to Holland, on the railway connecting Cologne with Amsterdam, and here the baggage of travellers is inspected by the custom-house officials. The minster is the oldest church in that part of the Rhine country. Woollens, hosiery, linens, hats, and other goods are manufactured, and there is an active shipping trade.

**EMMET**, a N. county of Michigan, bordering on Lake Michigan and the straits of Mackinaw; area, about 700 sq. m.; pop. in 1870, 1,211. It is indented by numerous bays. The chief productions in 1870 were 4,452 bushels of Indian corn, 5,972 of oats, and 40,730 lbs. of maple sugar. Capital, Little Traverse. (See EMMETT.)

**EMMET. I. Robert**, an Irish revolutionist, born in Dublin in 1780, hanged in the same city, Sept. 20, 1803. He gained high honors at Trinity college, from which he was ultimately expelled for avowing himself a republican. He joined the association of United Irishmen, whose object was to separate Ireland from Great Britain and to establish an independent republic, and he was implicated in the rebellion of 1798. After the failure of this attempt he escaped to France, returned secretly to Dublin in 1802, reorganized the malcontents, established various depots of powder and firearms in different parts of the city, and fixed upon July 23, 1803, as the time to seize the castle and arsenals of Dublin. On the evening of that day he directed the distribution of pikes among the assembled conspirators, to whom he delivered an animated harangue. The insurgent band, marching with cheers into the principal street, and swelling into an immense and furious mob, assassinated Chief Justice Kilwarden, who was passing by in his carriage; but they hesitated to follow their enthusiastic leader to the castle, and dispersed at the first volley from a small party of soldiers. Emmet escaped to the Wicklow mountains. After the failure of the first blow he checked the other movements which had been projected, husbanding his resources in the hope of soon renewing the revolt. He might have evaded the pursuit of the government, but an attachment for Miss Curran, the daughter of the celebrated barrister, induced him to return to Dublin to bid her

farewell before leaving the country. He was tracked, apprehended, tried, and convicted of high treason. He defended his own cause, delivering an address to the judge and jury of remarkable eloquence and pathos, met his fate with courage, and won general admiration for the purity and loftiness of his motives. His fate and that of Miss Curran are subjects of two of the finest of Moore's Irish melodies. **II. Thomas Addis**, a politician and lawyer, brother of the preceding, born in Cork, April 24, 1764, died in New York, Nov. 14, 1827. He graduated at Trinity college, Dublin, studied medicine at the university of Edinburgh, visited the most celebrated schools of the continent, then selected the legal profession, studied two years at the Temple in London, and was admitted to the bar of Dublin in 1791. He soon became a leader of the association of United Irishmen, and was one of a general committee to superintend all similar associations, having rebellion for their ultimate object. He was arrested with many of his associates in 1798, and was finally conveyed a prisoner to Fort George in Scotland, where he was confined for more than two years. After the treaty of Amiens he was liberated and permitted to withdraw to France, the severest penalties being pronounced against him if he should return to Ireland. His wife obtained permission to join him on condition that she should never again set foot on British soil. From Brussels, where he passed the winter of 1802-'3, he saw his brother Robert embark in the enterprise which led him to the scaffold. He came to America in 1804, rose to eminence in his profession in New York, and was attorney general of that state in 1812. While in prison in Scotland he wrote sketches of Irish history, illustrative especially of the political events in which he had taken part, which were printed in New York in 1807, under the title "Pieces of Irish History." His biography was written by C. G. Haynes (London, 1829), and a monument was erected to him in St. Paul's churchyard, New York. **III. John Patton**, an American physician, son of the preceding, born in Dublin, April 8, 1797, died in New York, Aug. 13, 1842. He came with his father and other Irish exiles to the United States, was educated for three years in the military school at West Point, resided one year in Italy, and studied medicine after his return. His delicate health obliging him to seek a milder climate, he removed to Charleston in 1822, and began practice. He was in 1824 elected professor of chemistry and natural history in the university of Virginia, and during several years was a contributor to Silliman's "Journal."

**EMMETT**, a N. W. county of Iowa, bordering on Minnesota, and intersected by the East and West forks of Des Moines river; area, about 450 sq. m.; pop. in 1870, 1,392. There are several lakes in the county. The chief productions in 1870 were 29,621 bushels of wheat, 12,816 of Indian corn, 27,819 of oats, and 6,948 tons of hay. Capital, Esterville.

**EMMETTSBURG**, a town of Frederick co., Maryland, about 50 m. N. W. of Baltimore; pop. in 1870, 706. It contains several churches, an academy, an institute for girls under the care of the sisters of charity, and Mount St. Mary's college and theological seminary, a Roman Catholic institution, organized in 1808. In 1871 the college had 26 professors and instructors, 161 students, and a library of 8,000 volumes; the theological department had 4 professors and 25 students.

**EMMONS, Nathanael**, an American theologian, born in East Haddam, Conn., April 20, 1745, died in Franklin, Mass., Sept. 23, 1840. He graduated at Yale college in 1767, was licensed to preach in 1769, and ordained pastor of the church in Franklin in April, 1773, continuing in the pastorate till 1827. He claimed to be a genuine Calvinist, though differing from the theological views of Calvin in several important respects. Of some of his peculiar speculations, one is, that there is no such thing as holiness or sinfulness except in the exercise of the voluntary affections, so that there is no depravity except in voluntary disobedience; and another, that God is the efficient, producing cause of every act of the human mind, thus making the will of God the source of all sinfulness as well as holiness, while every moral act, he would claim, is at the same time perfectly free and voluntary on the part of man. Dr. Emmons was one of the founders and first president of the Massachusetts missionary society, and one of the editors of the "Massachusetts Missionary Magazine." He guided the studies of some 87 theological students. His writings published in his lifetime were numerous, and his complete works, in 6 vols., edited with a memoir by the Rev. Jacob Ide, were published in Boston in 1842. See also "Memoir of Nathanael Emmons," by Professor Edwards A. Park, D. D. (Andover, 1861).

**EMORY, I. John**, a bishop of the Methodist Episcopal church, born in Queen Anne's co., Md., April 11, 1789, died in Baltimore co., Dec. 16, 1835. He was admitted to the bar at the age of 19, but soon abandoned the legal profession, and in 1810 joined the Philadelphia conference. During the following ten years he filled important stations in Washington, Philadelphia, Wilmington, and other cities. In 1820 he was chosen the first delegated representative of the Methodist Episcopal church of America to the British Wesleyan conference. From 1824 to 1832 he was book agent and editor of the book concern in New York. In this difficult position he displayed a rare combination of intellectual power and culture with business habits, by which the embarrassments that had surrounded the concern from its organization were entirely removed and a better policy inaugurated. He was the originator of the publishing fund and the founder of the "Methodist Quarterly Review." In 1832 he was elected bishop. In this capacity he was especially active in forwarding the educational interests

of the church, being one of the chief founders of Dickinson college and the originator of a plan designed to aid in the education of the sons of the clergy. Besides contributing nearly every original article in the first two volumes of the "Methodist Quarterly Review," he wrote two pamphlets in reply to Bishop White's "Objections against Personal Assurance by the Holy Spirit;" "The Divinity of Christ vindicated against the Cavils of Mr. John Wright;" "The Defence of our Fathers;" and "The Episcopal Controversy Reviewed." His son published his biography with a collection of his writings (8vo, New York, 1841). **H. Robert**, an American clergyman, son of the preceding, born in Philadelphia, July 29, 1814, died in Baltimore, May 18, 1848. He graduated at Columbia college in 1831, and commenced the study of law. In 1834 he was called to the chair of ancient languages in Dickinson college, resigned his professorship in 1839, and entered the Baltimore conference of the Methodist Episcopal church; but in 1842 he was recalled, as president *pro tem.*, during the absence of President Durbin, upon whose resignation Dr. Emory was chosen his successor. This office he held until the close of his life. Besides a life of his father, he wrote a "History of the Discipline of the Methodist Episcopal Church" (8vo, New York, 1843; revised and brought down to 1856 by the Rev. W. P. Strickland), and an unfinished "Analysis of Butler's Analogy," which was completed by the Rev. George R. Crooks (1856).

**EMPEDOCLES**, a Greek philosopher, born in Agrigentum, Sicily, flourished about the middle of the 5th century B. C. The son of a rich family, he was instructed by the Pythagoreans, and was acquainted with Parmenides and Anaxagoras. Like his father Meton, the leader of the popular party at Agrigentum, he saved the republic from a dangerous conspiracy, and refused the supreme power. A priest and a poet, a physician and a philosopher, his contemporaries esteemed him as a god; Plato and Aristotle admired him, and Lucretius sang his praises. It is said that he saved the life of a woman in a lethargy from which other physicians were powerless to revive her; and that he blocked up a mountain gorge through which pestilential winds were driving upon Agrigentum, and at another time stopped the raging of the plague by turning two rivers through a morass. His vanity equalled his ability. He appeared in public only in the midst of a retinue of attendants, with a crown upon his head, sandals of brass on his feet, his hair floating over his shoulders, and a branch of laurel in his hand. He proclaimed his divinity himself, and it was recognized throughout Sicily. It was his aim to affect the imagination not less than the reason. In his old age he left Sicily, not, as has been said, to converse with the priests of Egypt and the magi of the East, but to teach philosophy in Greece. He visited Thurium and Athens, sojourned in the Pelopon-

nesus, and read a poem at the Olympic games. His last days were passed in obscurity in the Peloponnesus. Some imagined that he was translated to heaven; others that he was drowned in the sea; that he fell from his chariot; that he was strangled by his own hands; or that he plunged into the crater of Etna, in order by hiding his body to certify his divinity, but that the volcano subsequently belched forth one of his sandals. The works of Empedocles were all in verse, embracing tragedies, epigrams, hymns, and an epic. The most important of them were two didactic poems, one on "Nature," the other on "Purifications," treating of worship and magic, and containing his religious precepts. Fragments only of these remain, but those of the treatise on nature are sufficient to give an idea of the plan of the work. It consists of three books: in the first, after stating the conditions of human knowledge, he treats of the universe in general, of the forces which produce it, and the elements which compose it; in the second, of natural objects, of plants and animals; and in the third, of the gods and divine things, and of the soul and its destiny. A Homeric spirit, as Aristotle calls him, he personifies and deifies everything, and robes himself in symbols and mystery. The doctrine of Empedocles is developed in the "Sophist," the "Meno," and the "Phædo" of Plato, and in the "Soul" and the "Metaphysics" of Aristotle. The best edition of his remains is that by Karsten (Amsterdam, 1838), which is furnished with admirable dissertations.

**EMPEROR** (Lat. *imperator*, commander), a title bestowed in the Roman republic on chief commanders of great armies, on consuls elect before entering upon their office, and often used by victorious troops to hail on the battle field a successful general. In later times it designated the highest authority in the state. Cæsar, returning from his last campaign, after the victory of Munda (45 B. C.), received it in this sense, but died soon after. Octavianus Augustus, after the battle of Actium (31 B. C.), assumed this now regal title in preference to *rex*, and Rome became an empire. Augustus and his successors took in addition the name of Cæsar, and both the title and the name (*Kaiser*) were afterward adopted by monarchs of other states. When the rule of the Roman empire was divided, the name Cæsar designated the adopted assistant of the emperor, who was himself honored by the title of Augustus. These titles disappeared in the West with the fall of Rome (476), but continued in the eastern or Byzantine empire for nearly ten centuries longer. During the crusades we find also a Nicæan and a Trapezuntine empire in the East. But all these eastern states were swept away and replaced by the power of the Turks, whose sultans never officially adopted the title of the vanquished Christian monarchs. This had been restored in the mean while in the West by Charle-

magne, who received the imperial crown from the hands of Leo III. at Rome on Christmas day, 800, and was hailed by the people with shouts of "Life and victory to Carolus Augustus, the God-sent, pious, and great emperor of Rome, the bringer of peace." When the empire of this great Frankish monarch was divided by his grandsons, the title of emperor of Rome was given to the eldest of them, the king of Italy, and his descendants bore it until it was taken (962) by the mightier king of Germany, Otho I. And now began a long series of expeditions to Italy, undertaken by the German monarchs, in order to be crowned in Milan with the iron crown of Lombardy, and in Rome by the pope with that of the Roman empire; a series of struggles between the emperors, claiming the sovereignty of the Roman world according to their title, and the popes, claiming the same as successors of St. Peter; between the worldly and spiritual heads of the Christian nations. German bravery and Italian diplomacy were by turns victorious and vanquished; emperors were humiliated, popes were stripped of their dignity; Germany was distracted and Italy desolated. The reformation struck at the pope, and indirectly at the empire. The German kings, who usually had been elected exclusively from Frankish or German houses, in earlier times by all, but later only by the greatest princes of Germany, who were hence called electors, gave up their Roman imperial pretensions, and were crowned in Germany as emperors of that country. At their coronation, celebrated in Aix-la-Chapelle, Angsburg, Ratisbon, or Frankfort, the emperors were obliged to sign an instrument, called capitulation, containing the conditions under which they were raised to their dignity. They lived in *palatia* set apart for their use (*Pfalzen*), in later times in their hereditary dominions. The wars of the reformation broke the ancient forms and institutions; the imperial dignity became almost hereditary in the house of Austria; the other German states were made nearly independent; Prussia became a kingdom under Frederick I.; and the unity of Germany was virtually destroyed. The wars that followed the French revolution wrought still greater changes, and when Napoleon had assumed the imperial dignity (1804), and founded the Rhenish confederacy, Francis II., who had proclaimed himself emperor of Austria in 1804 (as such Francis I.), in 1806 finally renounced the German imperial title, and what was once the Roman, now the German, empire expired. Its restoration was during the revolutionary period of 1848-'9 the favorite idea of a party in the Frankfort parliament; but the refusal of the king of Prussia to accept the imperial crown made the scheme a failure.—Several other monarchies of Europe had taken the imperial title. Russia assumed it under Peter the Great (1721), and the assumption was in time acknowledged by all the states of Europe. The empire of the French, founded

by Napoleon on the ruins of the republic, perished at Waterloo (1815), but was revived after two revolutions by the nephew of its founder (1852), and was succeeded by a republic, proclaimed Sept. 4, 1870. The empire of Germany was reestablished by the assumption of the title of emperor by King William of Prussia, Jan. 18, 1871. On the American continent several empires have been established, but most of them destroyed by revolutions. That of Mexico under Iturbide (1822) was ephemeral; under Maximilian it lasted from June 12, 1864, to June 19, 1867. That of Brazil is governed constitutionally. That of Hayti, which was nominally constitutional, was overthrown in January, 1859, and replaced by a republic. The Asiatic states of China, Japan, and Anam, and the African Fez and Morocco, are also often called empires.

**EMPHYSEMA** (Gr. *ἐμφύσημα*, inflation, from *ἐν*, in, and *φυσᾶν*, to blow), a diseased condition of man and animals, in which gases are developed in or have been introduced into any part of the body; generally restricted to the dilatation of the cells of areolar tissue or of the lungs by atmospheric air. Gaseous collections in serous cavities, or in canals lined with mucous membrane, have received other names. Three kinds are usually described, which may be called surgical or traumatic, spontaneous, and pulmonary emphysema.—Traumatic emphysema, though always subcutaneous in the commencement, is not always accompanied by wound of the skin; it may occur after severe contusions of the chest, or after fracture of the ribs, the air cells of the lungs being ruptured, and in the latter case punctured by the broken bone, with or without external communication. In any of these conditions, if the wound of the lung be small, and especially if it be not in direct connection with an opening in the skin, the respired air, not being able to pass out freely, becomes infiltrated in the areolar or cellular tissue, forming a soft and crepitating swelling, which may extend over a great part of the body; during inspiration the air escapes into the cavity of the chest through the wound in the lung, and during expiration, being compressed between the lung and the thoracic walls, it is forced into the subcutaneous cells, the amount tending to increase at each performance of the respiratory act. Emphysema may arise from any portion of the air passages, and frequently is seen accompanying wounds of the larynx and trachea; if the external wound be extensive, and the opening in the lung or trachea small, this complication is not likely to occur. The ordinary symptoms are painful constriction of the chest at the injured part, and difficulty of breathing, which may become almost insupportable, and even produce death by suffocation. The swelling of emphysema may be distinguished from effusions of fluids under the skin by its crepitation and elasticity, by its not pitting on pressure of the finger, and by the absence of redness, pain, and weight.



After distending the cellular tissue under the skin, the air may penetrate between the muscles, along mucous canals, vessels, and nerves, to the inmost recesses of the organism. The treatment consists in letting out the confined air by minute punctures with a lancet, and preventing its reaccumulation by proper bandages, and in cases of extreme oppression by paracentesis or incision of the thoracic walls; the cure may be hastened by antiphlogistic measures, and by stimulating applications and frictions. In Europe it is not uncommon for persons desirous of securing immunity from military service, and for purposes of mendicancy and deception, to inflate with air various parts of the surface of the body, pretending that their condition is the result of chronic or congenital diseases; the treatment in these cases consists in scarifications, bandages, and tonic frictions. Spontaneous emphysema may occur after exposure to great cold, in certain cases of internal poisoning and of poisonous bites, after copious bleedings and various severe accidents, and in debilitated conditions accompanied by gangrene. The treatment for this is the same as for the preceding variety.—Pulmonary emphysema may be either vesicular or interlobular. In the first the vesicles are enlarged, ruptured, and united, and the lung, when the chest is opened, may be so distended, more especially the upper lobes, as to protrude from its cavity; when only one side is affected it presses upon and displaces the heart and the other lung; such diseased portions are strongly crepitant, part with their contained air with difficulty, and float very lightly on water. In interlobular emphysema the distended vesicles assume an irregular form, sometimes of considerable size, and are situated just under the pleura; and the emphysematous swelling may be made by pressure to move under the serous covering as far as the next lobular division of the organ. Sometimes the enlarged vesicles are not in the subserous tissue, but in the tissue separating the lobules, between which they may descend to a considerable depth. These varieties are usually combined, their symptoms are the same, and the latter is generally considered the consequence of the former, the distention and rupture of the vesicles proceeding to a greater extent. Laennec and Piorry maintained that pulmonary catarrh was one of the principal causes of the dilatation of the vesicles, which, unable to free themselves from the viscid mucus without great effort, of necessity became enlarged. Louis seems to consider that some power of active dilatation is brought into play. Admitting the connection between emphysema and obstructed bronchi, with the first named authors, there is no necessity for making the former a direct consequence of the latter; measured by a pressure gauge, the forced expiratory act has been found one third more powerful than the act of forced inspiration; as Dr. W. T. Gairdner has well observed (in his work on bronchitis), whenever viscid obstructions

are to be removed from the air passages, the air is gradually expelled from the affected part of the lung by expiration, and they become collapsed in proportion to the obstruction. Emphysema is the direct opposite of bronchial collapse, and its indirect consequence; because, whenever a part of the lung is obstructed or collapsed from bronchitis or any other cause, the air during inspiration must rush with greater force and volume into the portions still freely open. Bronchitic accumulation and collapse are most common at the posterior and lower part of the lungs, and emphysema on the free anterior borders; the emphysematous portions are easily inflated from the bronchi, while the collapsed parts are not. Emphysema is, therefore, essentially a mechanical lesion from distention of the air cells, in proportion to which the flow of blood through the ultimate capillaries of the lungs is arrested, causing absorption of their walls, and tension and obliteration of their vessels. In the case of Mr. E. A. Groux, with congenital fissure of the sternum, in the course of prolonged forced expiration, the chest and abdomen became smaller, the veins at the root of the neck swollen, the upper intercostal spaces convex, and the fissure assumed its greatest width; and above the pulsatile cardiac tumor was a protruding mass which percussion showed to be the anterior portion of the upper lobe of the right lung. This can throw little light on the ordinary causes of emphysema, though the cells are doubtless dilated, because the protrusion is evidently due not so much to the obstructed passage of air or blood as to active muscular effort, and to the raising of the whole thoracic contents by the diaphragm and abdominal muscles in a cavity whose bony wall is deficient in front, where of course the free portion of the lung would protrude. Emphysema has been traced to compression of the bronchi by tumors; to the great respiratory efforts required in playing on certain wind instruments, showing the connection between this disease and forced expiration, and as partly exemplified in the above case of Mr. Groux; the disposition to this disease has also been considered hereditary, and doubtless many cases of so-called hereditary phthisis or asthma are due to the vesicular dilatation consequent on spasmodic bronchial contractions. It is found in both sexes, at all ages, and in all constitutions; once developed, it remains during life, sometimes stationary, but generally increasing, with irregular intervals of ease; the dyspnoea is sometimes such that the patient is obliged to sit up in order to breathe; slight causes, as a catarrh, exposure to irritating gases or dust, or vivid emotions, are sufficient to bring on an attack. Examination of the chest will show an enlargement of the affected side at the upper region of the ribs and intercostal spaces. On percussion the chest is very sonorous, and the respiratory sounds feeble, with râles sonorous, dry, or humid, according to the accompanying catarrhal condition, and the

presence or absence of cough. It is a very common disease, generally chronic in its nature, but sometimes acute and speedily fatal. It may be known by the occurrence of dyspnoea, without palpitations, disease of the heart, œdema, or fever, and often without any signs of catarrh. The principles of treatment are to guard against pulmonary congestion by proper depletives, to diminish the frequency of respiration by opium and other sedatives, to strengthen the weakened system by tonics, to relieve the obstructed bronchi by emetics and expectorants, and to avoid all the exciting causes of catarrh and bronchitis, the most frequent originators and aggravators of the disease.

**EMPOLI**, a town of Italy, in the province and 16 m. S. W. of the city of Florence, on the left bank of the Arno; pop. about 6,500. It is situated in a fertile valley, and is surrounded by walls flanked with towers. The collegiate church, built at the close of the 11th century, contains fine statuary and excellent pictures, including Giotto's "St. Lucia in the Cavern." The adjoining baptistery and the San Stefano and Santa Croce churches contain likewise several notable paintings. The principal manufactures are cotton, leather, glass, beaver hats, earthen vases, and the so-called Tuscan straw bonnets, the straw being a local product.

**EMS**, a river of N. W. Prussia, rising in the province of Westphalia, near the S. E. extremity of the Teutoburg forest, on the confines of Lippe-Detmold. It flows first S. W. and then N. W. through Westphalia, and finally N. through Hanover, until it empties through the Dollart estuary into the North sea near the town of Emden and the boundary of Holland. Length of course, about 200 m. It is navigable for vessels of 200 tons to a distance of about 14 m. from its mouth; for small vessels as far as the town of Rheine, about 75 m. from the sea, and a few miles S. of the Hanoverian boundary. Its chief affluents are the Hopster-Aa, Haase, and Leda on the right, and the Werse on the left. The Ems enters the estuary of Dollart by four streams, or "gats," separated by islands, the chief of which is that of Borkum.

**EMS**, a market town and watering place of Prussia, province of Hesse-Nassau, in the valley of the Lahn, 7 m. S. E. of Coblenz; pop. in 1871, 5,438. It is one of the most famous resorts of Germany, its waters being used with great effect, especially against chronic nervous diseases, both for bathing and drinking. On July 13, 1870, the famous interview between King William of Prussia and the French ambassador Benedetti took place here, which was followed by the declaration of war by France.

**EMSER**, Hieronymus, a German theologian, born in Ulm, March 26, 1477, died Nov. 8, 1527. In 1502 he became professor at the university of Erfurt, and in 1504 established himself at Leipsic, where he lectured at the university, and in the year following Duke George of Saxony made him his secretary. With Luther and the theologians of Wittenberg generally he

was on good terms until the disputation of Leipsic in 1519, from which time he made, in union with Dr. Eck, incessant endeavors to oppose the increasing influence of Luther and the progress of Protestantism. He attacked the German translation of the Bible by Luther as erroneous, whereupon it was forbidden in ducal Saxony by Duke George. Emser then himself published a German translation of the New Testament, made from the Vulgate (Dresden, 1527). He also wrote *Vita S. Bennonis*.

**EMU** (*dromaius Novæ Hollandiæ*, Latham), a bird closely allied to the cassowary, a native of Australia and the adjacent islands. The emu differs from the cassowary in its broader bill, in its head covered with feathers above, and in its smaller and more obtuse claws; as in the latter, the cheeks and sides of the neck are naked, the legs long and robust and protected by strong scales, and the wings and tail not



Emu (*Dromaius Novæ Hollandiæ*).

apparent; the middle toe is the longest, the inner the shortest. This bird was named emu by the English colonists, who confounded it with the cassowary or emu of the Moluccas; to distinguish them, ornithologists call the present bird the New Holland emu. There is only one species of the genus, living in the eucalyptus and casuarina forests in the Australian islands. Its length is about 7 ft.; its plumage is thick, and of a brownish color. The feathers are remarkable from their two central stems being united at the base, bearing simple barbs, and sometimes very short barbules. The form is thick and heavy, the back arched, the denuded neck of a violet color, and the feathers on the head are few, simple, and hair-like. The emu presents the closest analogy to the ostrich in its anatomical structure; a wide membranous sac is formed below the crop by a dilatation of the œsophagus, which ends in a slightly developed gizzard; the intestinal canal is about 16 ft. long; the windpipe is very long, and at its 52d ring opens into an immense muscular sac, whose

use is not well ascertained; according to Wagner, the bones of the wrist are wanting in this bird. The natives of New South Wales call the emu *parembang*. It is timid, runs with great rapidity, and is very rarely taken; it was once common in the neighborhood of Sydney, but civilization has driven it beyond the Blue mountains. It prefers open shrubby places and sandy plains. When pursued it takes readily to the water, and swims with its body mostly submerged. It feeds on fruits, berries, roots, and various herbs. The female lays six or seven eggs, in a slight hollow scratched in the earth; the male hatches the eggs, and takes care of the brood until they can provide for themselves; the young are grayish with four bands of bright red. The flesh is eaten by the natives, and is said to have the taste of beef.

**ENALIOSAURIANS** (Gr. *ἐνάλιος*, marine, and *σαῦρος*, a lizard), an order of fossil marine reptiles, found in the liassic, triassic, and cretaceous epochs. They unite characters which appear at first sight incompatible, having the vertebræ of fishes, the teeth of crocodilians, the body of lizards, the paddles of cetaceans or marine turtles, and some have a long snake-like neck. Many of these aquatic saurians attained a large size, and from their voracity must have been the terror of the waters of the secondary epoch, after the disappearance of the great sauroid fishes of the carboniferous period. Pictet considers them as coming nearest to the saurians, though so different from any existing types as to require the establishment of a new order, whose principal characters are biconcave vertebræ, wider than long, with laminae feebly united to the bodies; conical teeth, without cavity at their base, implanted in short deep-seated alveoli; and four short, flattened limbs, whose fingers are formed by discoidal bones disposed like those of cetaceans. They have been divided into two groups, whose characters correspond also to their geological position. The ichthyosaurians (including the *ichthyosaurus* and *plesiosaurus*) have well developed crania, with small fossæ and cavities; these have been found in the Jurassic and cretaceous strata. The other group, the simosaurians (including *nothosaurus*, *simosaurus*, &c.), have the cranium with very large temporal fossæ and orbital and nasal cavities; they are found only in the triassic strata. The first two genera are the best known, and the most common in the strata of England and Germany; the *ichthyosaurus* must have attained a length of 25 ft., and the *plesiosaurus* of more than 12, and both presented forms most unlike those of any existing animals, though admirably adapted to the circumstances in which they lived. (See **ICHTHYOSAURUS**, and **PLESIOSAURUS**.)

**ENAMELLING**, the art of applying a coating of vitreous substance called enamel to a surface of glass or of metal, and causing it to adhere by fusion. In its homeliest application it is a sort of glazing, and as applied by modern methods to ornament and protect surfaces of

cast or wrought iron, it may be considered simply a process of japanning. The facility with which colors might be introduced in vitreous compounds or applied to them, and become fixed by a subsequent fusion or baking, made the art in early times exceedingly popular, and in the middle ages it attained a higher rank even than it now holds, as one of the fine arts. The ancient Persians and Arabians appear to have practised it upon earthenware and porcelain; and the mode of coloring this ware at the present day is properly a process of enamelling. Articles of pottery enamelled in colors are found among the ruins of ancient Thebes, and in many of the cities of Egypt are buildings constructed of enamelled bricks taken from the ruins of older cities. Wilkinson says: "It has been questioned if the Egyptians understood the art of enamelling upon gold or silver, but we might infer it from an expression of Pliny, who says, 'The Egyptians paint their silver vases, representing Anubis upon them, the silver being painted and not engraved;' and M. Dubois had in his possession a specimen of Egyptian enamel." From the Egyptians the art is supposed to have passed to the Greeks, and afterward to the Romans. Brongniart, however, in his *Traité des arts céramiques*, traces its introduction into Italy from the Balearic isles by the Spaniards, who derived the art from the Arabs. The Romans introduced it into Great Britain, as appears from various enamelled trinkets that have been dug up there with other vestiges of the Roman conquerors. That the Saxons practised the art appears from an enamelled jewel found in Somersetshire, and preserved at Oxford, which according to its inscription was made by direction of the great Alfred. The gold cup given by King John to the corporation of Lynn in Norfolk shows, by the colored enamelled dresses of the figures with which it is embellished, that the Normans also practised the art. Among the Gauls enamelling upon metallic surfaces is understood to have been in use in the 3d century. As practised upon earthenware in the style called by the French *faïence commune ou émaillée*, and by the Italians majolica ware, it was carried to great perfection in the 16th century at Castel Durante and at Florence by the brothers Fontana d'Urbino. Other Italian cities adopted the art, and Faenza became famous for the works of Guido Selvaggio. The high style of art attained hardly outlived the artists who perfected it, and from 1560 it gradually deteriorated. Bernard Palissy, by practice of 25 years directed to the production of a cup like one of great beauty shown to him, sought to introduce the art in France, and his works became very famous, but his method died with him. His productions were interesting from being true copies of natural objects, in relief, and colored with exact faithfulness. Of late years the art has been revived in France, chiefly through the skill of Brongniart; and in Berlin also beautiful work of the

kind has been executed by Feilner.—Painting in enamel, as practised upon plates of gold and copper, can hardly be regarded as applied to works of high art until the 17th century. Jean Toutin, a goldsmith at Châteaudun, appears about the year 1630 to have first made enamels of fine opaque colors, and applied them to portraits and historical subjects. Other artists profited by his instructions, and several miniature painters attained great distinction in this branch. The art afterward fell into disuse, and was only applied to ornamenting watch cases and rings. In the early part of the present century it reappeared in some fine portraits by Augustin, and various French and English artists have since executed many portraits in this style, distinguished for the brilliancy of their colors, and the more valuable for their permanence. A piece of five inches in its longest dimensions was considered the largest that could be undertaken with safety; for with the increase of size the liability of injury to the enamel by cracking, and to the plate by swelling and blistering in the several processes of baking, rapidly increased; but by backing the metallic plate with one of porcelain, the work is now executed in pieces even 18 inches long by nearly as great a breadth. The process is usually conducted as follows: The plate is coated on both sides with white enamel, and on this the design is lightly sketched with a pencil. The colors, finely ground and mixed with oil of spike, are then laid on as in miniature painting. By gentle heat the oil is evaporated, and in an enameller's fire the plate is next made red-hot to incorporate the colors with the enamel. The painting may then be retouched, and the colors again be burned in, and this may be repeated several times. But the greatest accuracy in the first drawing and coloring is essential for a perfect picture. In this department may be consulted the work of Count de Laborde, *Notice des émaux exposés dans les galeries du Louvre*.—In the ordinary processes of enamelling, the enamels used for the ground are opaque, and must bear a higher degree of heat without fusing than the colored enamels, which are afterward melted into them. They are made after a great variety of recipes, according to their uses. All those designed for metallic surfaces have a transparent base, which is rendered opaque by the substitution of combined oxide of lead and oxide of tin, in the place of the oxide of lead used as one of its ingredients. Five different mixtures of the two oxides are in use, the proportions varying from  $3\frac{1}{2}$  parts of lead and 1 of tin to 7 parts of lead and 1 of tin. The two metals are melted together, and the combined oxide is removed as fast as it appears upon the surface. When the oxidation is as thoroughly effected as practicable, the product is well washed to remove any particles of metal that may have escaped oxidation, as these would greatly impair the quality of the enamel; for the same

reason it is essential that the metals themselves should be absolutely pure. One or other of the mixtures of oxides obtained by the method described is next melted with proper quantities of silica, saltpetre, and a little borax; the last gives greater fusibility as its proportion is increased, and no more is used when the enamel is to be applied upon copper or silver than upon gold. The plates are sometimes chemically acted on by the enamel, and if the gold of the gold plates is alloyed with too much copper, the appearance of the enamel is injured. An excellent enamel is prepared by mixing 30 parts of saltpetre, 90 of silica, and 250 of litharge; after fusion it is white, and may be used in taking photographs without collodion—gum, honey, and bichromate of potash being used instead. For making colored enamels, either the opaque or transparent enamel serves as a base, and with it is melted a suitable proportion of some metallic oxide as a coloring matter; for a blue enamel, the opaque is used with oxide of cobalt; for a green, oxide of chromium, or binonide of copper; for a violet, peroxide of manganese; for a yellow, chloride of silver; for a purple, purple of Cassius; and for a black, the transparent enamel is used with mixed oxides of copper, cobalt, and manganese. The different enamels, being prepared beforehand, are crushed to powder when wanted for use, and then kept at hand under water in vessels well covered to protect them from all impurities. The metallic surfaces to be coated are cleaned by boiling in an alkaline solution, and are then washed with pure water. The copper alloy in gold may be dissolved from the surface by boiling in a strong solution of 40 parts of saltpetre, 25 of alum, and 35 of common salt.—In the manufacture of enamelled earthenware, the white enamel is prepared by melting 100 lbs. of lead with 15 to 50 lbs. of tin, and adding to the oxides thus obtained the same weight of quartz sand, and about 30 lbs. of common salt. The whole being well rubbed together is melted; and though it may appear dark, it becomes white when reduced to powder and baked upon the utensils. The proportions of the materials employed are very variable, and other ingredients are often introduced, particularly oxide of manganese, the effect of which in small quantity is to yield its oxygen to any carbonaceous impurities that may be present, and remove these in the form of carbonic acid. The colored enamels are applied by painting them when finely ground, and mixed with some vegetable oil, upon the white enamel, either before or after this has been once heated, and then baking them in. The ovens for metallic articles are muffles made to slide closely into the furnace, and furnished with a small aperture through which the progress of the operation may be observed.—The enamelling of cast-iron cooking utensils was practised at the close of the last century, and a number of different mixtures have since

been in use. The use of lead must be carefully avoided in articles of this kind. Vessels of wrought iron are also treated by the same process; and iron pipe for conveying water is advantageously protected by a clean silicious enamel not liable to affect the purity of the water.—The process employed for many years by the Messrs. Clarke of England consisted in the use of the following composition and method: 100 lbs. of calcined ground flints and 50 lbs. of borax calcined and finely ground, to be mixed, fused, and gradually cooled. Of this, 40 lbs. are mixed with 5 lbs. of potters' clay, and ground in water to a pasty mass. The vessel, first thoroughly cleaned, is lined with a coating of this about one sixth of an inch thick, and left for it to harden in a warm room. A new coating is next added, prepared from 125 lbs. of white glass without lead, 25 lbs. of borax, 20 lbs. of soda in crystals which have been pulverized and fused together, ground, cooled in water, and dried. To 45 lbs. of this 1 lb. of soda is added, the whole mixed in hot water, dried and pounded. A portion of it is sifted over the other coating while it is still moist, and dried in a stove at the temperature of boiling water. The vessel is then heated in a stove or muffle till the glaze fuses. It is taken out, more glaze powder is dusted on the glaze already in fusion, and it is again subjected to heat. The *Polytechnisches Centralblatt* for 1872 recommends the following enamel for copper cooking vessels: 12 parts of white fluor spar, 12 of gypsum, and 1 of borax, finely powdered, and fused in a crucible; when cold the mass is again pulverized, and made into a paste with water, laid upon the metal, and fused. Small articles of enamel, as little toys imitating the figures of birds, &c., and also artificial eyes, are made by melting with the table blowpipe rods or tubes of enamel prepared for this purpose, and shaping them by hand, just as the glass blower works with tubes and rods of glass.—Enamelling of slates to imitate marble and malachite was introduced in London by Mr. G. E. Magnus. The art was first practised in the United States at Boston, and slates from Wales were imported for this purpose. Subsequently the slates of the Lehigh river were applied to this use in Lehigh co., Pa., and were also sent to Philadelphia to be there enamelled. In Vermont the business is now carried on at West Castleton, where are extensive quarries of slate, and an establishment of the same kind is in operation in New York. A great variety of useful articles are produced, among which the most important are billiard tables, mantels, tubs for bathing, sinks, &c. The slates are sawed to proper shape, planed to uniform thickness, and rubbed smooth with polishing stones. The ground color adapted to the marble it is designed to imitate is then laid on, and after this the variegated colors. The slab is then placed in an oven heated to 200°, and allowed to remain over night. In the morning

after cooling it receives a coat of varnish, and is returned to the oven till the next day. Other heatings and varnishings alternately succeed, with rubbing with pumice stone; and a final polishing with pumice stone, rotten stone, and the hand completes the process.

**ENCAUSTIC** (Gr. *έν*, in, and *καυστικός*, burning), a term applied to the method of fixing colors upon objects by burning them in. Enamelling in colors is an encaustic process. The word is most commonly used in its application to an ancient method of painting, in which wax was employed with the colors, and a coating of the same material was finally applied to the picture to preserve it from the action of the atmosphere and light. In modern use a peculiar kind of tiles are called encaustic; and by the French the same epithet is applied to preparations of wax used for polishing and protecting the surface of wood. The little that is known of the ancient art of encaustic painting is derived from the mention made of it by Pliny ("Natural History," lib. xxxv. ch. xi.), Marcianus (lib. xvii.), and Julius Paulus (lib. vii. *et seq.*). M. Bachelier, author of a treatise *De l'histoire et du secret de la peinture en cire*, produced a picture in wax in 1749. In 1829 M. de Montabert, in his *Traité de tous les genres de peinture*, favorably noticed the process, and M. Durozier of Paris soon after announced that he had perfectly succeeded with the method given by Montabert. The ancient methods appear to have consisted in the use of wax crayons, in which the colors were embodied, and which were used upon a heated surface, the outline of the picture having been first traced. The whole was afterward covered with a varnish of wax melted in and polished. The method of Count Caylus consisted of rubbing and melting wax into the canvas or panel, then coating the surface with Spanish white, and painting upon this with water colors. By warming the picture the colors are absorbed into the wax, and thus protected. Mr. J. H. Muntz recommends waxing only one side of the canvas, painting on the other in water colors, and then melting the wax through to fix them.—**ENCAUSTIC TILES** consist of a body of red clay, faced with a finer clay, which bears the ornamental pattern, and strengthened at the base with a thin layer of a clay different from the body, which prevents warping. The clay of the body is exposed to the weather for six months or more, and is afterward thoroughly worked over and tempered, and mixed with other substances, and at last evaporated at the slip-kiln. From a cubical block of this, formed in the usual method by slapping, a square slab is cut off with a wire, upon which slab the facing of finer clay colored to the desired tint is battled out and slapped down; a backing is then applied in the same way to the other side of the tile. It is then covered with a piece of felt, and put into a box press; a plaster of Paris slab containing the pattern in relief is then brought down upon the face of the tile,

and the design is impressed into the soft tinted clay. The hollows thus formed are filled with a semi-fluid clay of a rich or deep color poured into them and over the whole surface of the tile. In 24 hours this has become hard enough to admit of the surplus clay being removed, which is done by placing the tile, still in the box, upon a horizontal wheel, and as it revolves applying a knife or scraper entirely across, so as to rest upon the edges of the box. The surface is thus cut down so as to expose the pattern and the ground. The defects are removed with a knife, and the edges after being square are rounded off with sand paper. The tiles are kept for a week in a warm room called the greenhouse, and the drying is completed in another called the hothouse. They are then baked like other articles of pottery, except that double the ordinary time is given to the process, and the oven is left six days to cool before the tiles are taken out. They contract in baking from one eighth to one sixteenth of their dimensions. The process is supposed to be nearly the same as that employed in the middle ages in France and England in making pavements for churches, and also for the beautiful pottery called Henry II.'s ware, peculiar to France in the 16th century.—The French apply the term encaustic to preparations of wax used for covering furniture and floors, which are then polished by friction.

**ENCKE, Johann Franz**, a German astronomer, born in Hamburg, Sept. 23, 1791, died in Spandau, Aug. 26, 1865. He studied under Gauss at the university of Göttingen, served in the Hanseatic legion against Napoleon in 1813-14, and in 1815 entered the Prussian military service, but afterward accepted a situation in the observatory of Seeberg near Gotha. In 1825 he was appointed director of the royal observatory at Berlin. He wrote many valuable memoirs on astronomical subjects, of which the most important are the treatises published in the *Astronomische Nachrichten*, at Berlin, in 1831 and 1832, upon the comet then called by the name of Pons, the astronomer of Marseilles, who discovered it in November, 1818, but now known as Encke's comet. After its discovery Encke diligently applied himself to the determination of its orbit. Making use of the methods of Gauss, as explained in his work *Theoria Motus Corporum Cælestium*, of calculating an orbit assumed to be elliptical, he showed that its period of recurrence must be about  $3\frac{1}{2}$  years, and that it was probably the same comet observed by Méchain in 1786, by Caroline Herschel in 1795, and by Pons in 1805. He calculated the effects of the perturbations it would experience from the planetary bodies, especially from Jupiter, and predicted its return in 1822, though it would probably not be visible in Europe. On June 3 of that year it was discovered at the observatory of Sir Thomas Brisbane, governor of New South Wales. Encke predicted its return in 1825, and with each reappearance as predicted more

elements were afforded for computing its exact orbit. It appeared again Oct. 30, 1828, and he was able to fix its orbit as within that of Jupiter, its greatest distance from the sun being four times the earth's distance, and its least distance but one third that of the earth, and its period of revolution  $3.29$  years. By comparison of the times of its earlier and later apparitions, Encke was afterward led to detect a gradual acceleration of its movement, amounting to about  $2\frac{1}{2}$  hours on each revolution. This secular acceleration, never before recognized in the movement of any other celestial body, Encke ascribed to a resisting medium, which sensibly affects a body of the extreme rarity of this comet, which is transparent to its centre, but has no perceptible effect upon the denser planetary bodies. Resistance shortens the time of the revolution by giving greater effect to the attraction of the sun, which then draws the body more forcibly toward itself, lessening the major axis of the ellipse, and thus its orbit of revolution. In investigating the perturbing effects of the planets upon this comet, of Jupiter in its aphelion, and of Mercury in its perihelion, Encke was led to suspect that the mass of the former had been greatly underrated (a fact afterward established by Prof. Airy); and in 1838 he proved that Lagrange had ascribed nearly three times too great a bulk to Mercury. Encke's explanation of the cause of the acceleration is not universally accepted, although the fact itself is not questioned. Bessel particularly opposed the explanation; by the English astronomers it is more favorably received. Besides these investigations, Encke improved the theory of Vesta, and published a new method of computing perturbations, especially for orbits considerably elliptical. The planet Neptune was discovered at his observatory by Galle, his assistant. From 1830 Encke annually published the *Astronomisches Jahrbuch*, and from 1840 *Astronomische Beobachtungen auf der Sternwarte zu Berlin*. In 1845 he published dissertations *De Formulæ Dioptricis*; and in 1846 a treatise *Ueber das Verhältniss der Astronomie zu den anderen Wissenschaften*. In the autumn of 1863 he resigned his office.

**ENCRINITE** (Gr. *κρίνον*, a lily), a fossil genus of the order of crinoids, of the class echinoderms. It appeared among the earliest forms of animal life, its remains being preserved in the rocks of the Silurian period. In succeeding formations, nearly to the lias, they are often so abundant that calcareous strata extending over many miles are in great part made up of them. As described by Miller in his work on the crinoids, the animals of this family are furnished "with a round, oval, or angular column composed of numerous articulating joints, supporting at its summit a series of plates or joints, which form a cup-like body containing the viscera, from whose upper rim proceed five articulated arms, dividing into tentaculated fingers more or less numerous surrounding the aper-

ture of the mouth." In the encrinite the stem is cylindrical; in the kindred genus pentacrinite it is five-sided. The cup-like body is the portion representing the flower of the lily, for which the creature is named. When the tentacula are spread out, the appearance is that of an opened flower; when closed, they represent the bud. The stem served to attach the animal to any bodies in the water, and by the manner of articulation of the plates composing it, it admitted of much motion, swaying back and forth. By this means the head with its tentacula was brought within reach of its prey. The plates of the stem, separating into short cylinders, present the form in which the remains of this animal are most commonly seen. In the marble used for chimney pieces they are often very abundant, the polished surface presenting some of them of a different color from the ground in longitudinal section, some in oblique conical-formed cutting, and some in



ENCRIINITES.—1. *Periechocrinus* (*Actinoocrinus*). 2. Stem and Pelvis of ditto. 3. Pelvis of *Crotalocrinus* (*Cyathocrinus*). 4. *Dimercrinus* *Scosidactylus*. 5. *D. Decadactylus*.

circular disks, being transverse sections. By the disintegration of the rock the little joints of the fossil stem frequently fall out, and may be gathered in great numbers. Each has a hole through its centre. Dr. Mantell says he has found them preserved in tumuli of the ancient Britons, having evidently been worn as ornaments. In the north of England they are called "wheel stones" and St. Cuthbert's beads," and were formerly used for rosaries. The encrinites are remarkable for the multiplicity of small calcareous pieces, which make up the various parts of the animal—the stem, the parts that may be called the ten arms, the hands and fingers, and the numerous tentacula which proceed from them all. These pieces, as enumerated by Parkinson in his "Organic Remains," amount to not less than 26,000, thus showing a complexity of structure equal to any that is met with in the nearest living analogues of these ancient animals. The structure of one

of the fossil pentacrinites (a genus which began to abound as the encrinite disappeared, and has been represented in some of its species down to the present time from the lias, or indeed in a single species from epochs much more remote) has been cited by Dr. Buckland as "showing an equal degree of perfection, and a more elaborate combination of analogous organs than occurs in any other fossil species of more recent date, or in its living representative." The species thus cited is the Briarean pentacrinite of the lias. The *pentacrinus caput medusæ* is almost the only living analogue of the ancient crinoids. (See CRINOIDEA.)

**ENCYCLOPEDIA.** See CYCLOPEDIA.

**ENDER, Johann Nepomuk**, an Austrian painter, born in Vienna, Nov. 3, 1793, died there, March 16, 1854. He studied at the Vienna academy, and when he had hardly attained his majority won its four leading prizes. He accompanied the Hungarian count Szecheni on a journey through Greece and Turkey in 1818. In 1820 he went to Italy, and in Florence and Rome produced a number of works from Biblical and historical subjects. In 1827 he returned to Vienna, after spending a year in Paris. The more noteworthy of his works are his great cartoon of the entry of Christ into Jerusalem; "Judith," exhibited in 1824; and several frescoes of much merit, one of which, the last of his important productions, is in a chapel of the church of St. Stephen in Vienna.

**ENDICOTT, John**, governor of Massachusetts, born in Dorchester, England, in 1589, died in Boston, Mass., March 15, 1665. He was sent out by the "Massachusetts Company" to carry on the plantation at Naumkeag, or Salem, where he arrived Sept. 6, 1628. In April, 1629, he was chosen governor of "London's plantation;" but in August it was determined to transfer the charter and government of the colony to New England, and Winthrop was appointed governor. In 1636, with Capt. Underhill, Endicott conducted the sanguinary but ineffectual expedition against the Block Island and Pequot Indians. He was deputy governor of the Massachusetts colony from 1641 to 1644, in 1650, and 1654; and was governor in 1644 and 1649, from 1651 to 1654, and from 1655 to 1665. He was bold and energetic, a sincere and zealous Puritan, rigid in his principles, and severe in the execution of the laws against those who differed from the religion of the colony. So averse was he to everything savoring of popery, that he cut out the cross from the military standard. He was opposed to long hair, insisted that the women should wear veils in public assemblies, and did all in his power to establish what he deemed a pure church. During his administration four Quakers were put to death in Boston.

**ENDLICHER, Stephan Ladislaus**, a Hungarian botanist and linguist, born in Presburg, June 24, 1804, died in Vienna, March 28, 1849. He studied at the universities of Pesth and Vienna, and intending to become a clergyman, he en-

tered subsequently the archiepiscopal seminary in the latter city. After having received the minor clerical orders, he abandoned theology and devoted himself to the study of the natural sciences, especially botany. He continued at the same time his studies of the oriental languages, and obtained in 1828 a position in the court library of Vienna, where he was intrusted with the compilation of a new catalogue of the manuscripts. In 1836 he was appointed keeper of the court cabinet of natural history, and in 1840 professor of botany and director of the botanical garden of the university. During this period he exhausted his personal resources in supplying the institution with costly materials for the study of botany which the government failed to procure, and in publishing or aiding others in publishing valuable works. He corresponded with scientific men and institutions in every part of the world, and was one of the chief founders of the Vienna academy and of the *Annalen des Wiener Museums*. He presented his own choice library and rich herbaria to the state, and passed several hours every week for ten years in the society of the emperor Ferdinand; but he received no other reward than the title of *Regierungsrath*. The political turmoil of 1848 found him in pecuniary embarrassment, and becoming known as a sympathizer of the popular party, he was made the butt of the intrigues of his enemies, which hastened his death. Some believe that he died by his own hand. He made valuable contributions to the science of old German and classic literature, and pointed out new sources of Hungarian history, publishing *Fragmenta Theotisca Versionis antiquissimæ Evangelii Matthæi* (edited with Hoffmann von Fallersleben, 1834); an edition of two poems of Priscian (1828); and *Anonymi Belæ Regis Notarii de Gestis Hungarorum Liber* (1827). His linguistic publications comprise *Analecta Grammatica* (with Eichenfeld, 1836), and *Anfangsgründe der chinesischen Grammatik* (1845). His *Verzeichniss der japanesischen und chinesischen Münzen des kaiserlichen Münz- und Antikencabinetts* (1837) and *Atlas von China nach der Aufnahme der Jesuitenmissionäre* (1843) are finely executed, and deserve mention as specimens of his great liberality. The majority and the most valuable of his works treat on botany. Foremost among them are his *Genera Plantarum* (1831-'41), in which he lays down a new system of classification; *Grundzüge einer neuen Theorie der Pflanzen-erzeugung* (1838); and *Die Medicinalpflanzen der österreichischen Pharmakopöe* (1842). The principal of his other botanical works are: *Ceratotheca* (1822); *Flora Posoniensis* (1830); *Diesingia* (1832); *Atacta Botanica* (1833); *Iconographia Generum Plantarum* (1838); *Enchiridium Botanicum* (1841); and *Synopsis Coniferarum Sancti Galli* (1847). Besides these he wrote several works in conjunction with other scholars, and many of his minor writings are scattered among the periodicals of his time,

especially in the *Annalen des Wiener Museums*. (See BOTANY.)

**ENDOGENS** (Gr. *ἔνδον*, within, and *γένειν*, to produce), a class of plants so called because their stems increase in diameter by the deposition of new woody matter in the centre, in contradistinction to exogens, whose stems increase by the formation of a new layer of wood outside of that previously formed, and immediately beneath the bark. In endogens the stem has no medullary rays, concentric rings, or apparent distinction of pith, wood, and bark, but consists of fibres of woody or vascular tissue, distributed with little apparent regularity through the cellular system of the stem. They may be traced from the base of the leaves downward, some passing into the roots, and others curving outward until they lose themselves in the rind or cortical integument, which differs from the bark of exogens in that it does not increase by layers, and cannot be separated from the wood. As the plant grows, new threads or fibres spring from the freshly formed leaves, and passing first down the centre of the stem crowd the old ones out, and are finally directed toward the rind. In some plants the rind, being soft, is capable of unlimited distention; in others it soon indurates, and the stem consequently ceases to grow in diameter. The best example of this class of plants is the palm, whose branchless trunk, rising from 30 to 150 feet from the ground, and terminated by a simple cluster of foliage, has a striking and majestic appearance. The growth of this tree is from the terminal bud, and if the bud is destroyed the tree perishes. In some instances, as in the doum palm of Upper Egypt, and the pandanus or screw pine, two terminal buds appear and branches then shoot forth. The asparagus is an example of endogenous growth. Endogens are monocotyledonous; the veins of their leaves are almost uniformly in parallel lines connected by simple transverse bars; their flowers are trimerous, or have their sepals, petals, stamens, and styles in threes. They luxuriate in hot and humid climates, and comprise the greater number of plants contributing to the food of man, and but a small proportion of poisonous plants. They are generally shorter lived than exogens, though the dragon tree and others, whose growth is not limited by the hardening of the cortical integument of the stem, may attain a great age. The average age of the palms is perhaps 200 or 300 years.

**ENDOR**, a town of Palestine, W. of the Jordan, assigned to the tribe of Manasseh, although situated within the territory of Issachar. It was in a solitary valley, not far from this town, that the sorceress resided whom Saul went to consult on the evening before the fatal battle of Gilboa.

**ENDOSMOSE** (Gr. *ἔνδον*, within, and *ὄσμις*, impulsion), the action exhibited by one of two fluids of different densities and composition in passing through an organic membrane which separates them, till they become both of the



same density. Let a solution of sugar in a tube closed below with a slip of bladder tied across the end, and open above, be suspended in a vessel of water. The quantity of liquid in the tube is soon seen to increase by the passing through of the thinner fluid. It may even flow over and run down into the outer vessel, and so the action will go on until the membrane becomes partially decomposed, or until the two mixtures become uniform. Dutochet, who first observed this phenomenon, found that the height to which the fluid would rise increased with the density of the thicker fluid. With a membrane  $1\frac{1}{2}$  in. in diameter and sirup of the density 1.083, the liquid rose, in a tube  $\frac{1}{2}$  of an inch in diameter, more than  $1\frac{1}{2}$  in. in  $1\frac{1}{2}$  hours; with sirup of a density of 1.45 the fluid rose nearly 3 in.; and when the density was 1.228 the rise was 4 in. A considerable force is exerted in this movement; in sirup of density 1.3 Dutochet estimated it to be equal to the pressure of  $4\frac{1}{2}$  atmospheres. If the flow is drawn inward, the action is called endosmose; if outward, exosmose. It is supposed to be on this principle that the sap ascends in trees and fluids are diffused through animal bodies. Liebig, after describing some experiments, in which fluids were made to pass through nine membranes, to fill the vacant space left by evaporation of another fluid in a glass tube, remarks with reference to the application of the results to the processes taking place in the animal body as follows: "The surface of the body is the membrane from which evaporation goes constantly forward. In consequence of this evaporation, all the fluids of the body, in obedience to atmospheric pressure, experience motion in the direction toward the evaporating surface. This is obviously the chief cause of the passage of the nutritious fluids through the walls of the blood vessels, and the cause of their distribution through the body. We know now what important functions the skin (and lungs) fulfil through evaporation. It is a condition of nutrition, and the influence of a moist or dry air upon the health of the body, or of mechanical agitation by walking or running, which increases the perspiration, suggests itself." Interesting examples of this phenomenon are seen in the passage of the gases through membranes. If a tumbler, filled with air and covered at top with a thin sheet of India rubber, be placed under a bell glass filled with hydrogen, the gas will soon penetrate the cover and mix with the air; and this action will go on till the India rubber bursts open from the increased bulk of the contents of the tumbler. If the tumbler contained hydrogen and the bell glass air, the India rubber would be pressed in by the escape of the gas, leaving the portion remaining of greatly reduced density.

**ENDYMION**, in Greek legend, a shepherd of remarkable beauty, who retired every night to a grotto of Mount Latmus in Caria. As he slept the goddess Selene (the moon) became enamored of him, and leaving her chariot came

down to him. The eclipses of the moon were attributed to these visits. By Selene he had 50 daughters. Jupiter condemned him to perpetual sleep, or, according to other accounts, to 50 years of sleep.

**ENFANTIN, Barthélemy Prosper**, generally known under the name of Père Enfantin, one of the founders of St. Simonism, born in Paris, Feb. 8, 1796, died there, Sept. 1, 1864. He was the son of a banker, and with his fellow pupils was dismissed from the polytechnic school after March 30, 1814, for having on that day fired on the allied troops. He then became a commercial traveller, and in 1821 entered a banking house in St. Petersburg. He returned to France in 1823, and became cashier of a mercantile firm, at the same time joining the carbonari. In 1825 he made the acquaintance of Olinde Rodrigues, a follower of Saint-Simon, who introduced Enfantin to his teacher. After the death of Saint-Simon, May 19, 1825, Enfantin and Rodrigues began the publication of a journal, *Le producteur*, in which Enfantin broached new social and religious doctrines, which displeased many who at first supported it, and it was discontinued toward the end of 1826. Enfantin, however, continued to advocate his views by lectures and public meetings. The revolution of 1830 favored the movement, which was soon formally organized with Enfantin and Bazard as the chief leaders (*pères suprêmes*), and with the *Globe* newspaper, of which Michel Chevalier was editor, as its organ. A schism soon broke out between the leaders. Enfantin proposed the overthrow of all legislative and social restraint in the sphere of love and affection, except that of the "priest" or "confessor," who should have full command over the body and soul of his disciples for the control of their passions. Bazard declared this an attempt to convert Saint-Simon's economical doctrines into a religious creed, and a social order founded upon licentiousness, and withdrew in 1831. His secession was followed by that of the economical and political section of the school. But Enfantin persisted in his endeavors to establish a new religion. He addressed his followers (whom he estimated at 40,000 in France alone) with the authority of a superior being set apart by Providence for the purpose of inaugurating a new era for humanity through the emancipation and the agency of woman. He endeavored to find the female Messiah (*femme Messie*) who in his opinion was predestined to bear to him a new saviour of mankind, and in this search is said to have spent more than 250,000 francs in splendid entertainments. He still gained adherents and procured a loan of 80,000 francs for the establishment of industrial workshops. His meetings were closed by the authorities in May, 1832; but he now withdrew with 40 of his followers, among whom were Michel Chevalier and other eminent men, to some land which belonged to him in the vicinity of Paris, near Ménilmontant,

where they established a community and spent their time in manual labor and St. Simonian religious ministrations, over which Enfantin presided. Again arraigned by the government, Enfantin appeared in the court with two ladies as his counsel; but they were not permitted to plead his cause. After two days he was found guilty, and sentenced to a year's imprisonment, but was pardoned after a few months' detention. He spent two years in Egypt, then returned to France, devoted himself to agricultural pursuits, and was postmaster near Lyons. By the influence of his former disciples and associates he became in 1841 a member of the scientific board for Algeria. From 1845 to 1848 he was director of the Lyons railway. In November, 1848, he established, in concert with M. Duveyrier, a daily journal, *Le Crédit*, with a view of reconciling political reforms with his Utopian views of social relations; but the journal was discontinued in 1850. He again received an appointment in connection with the administration of railways, which he held until his death. His writings are not numerous. Among the principal are: *Traité d'économie politique* (1830); *La religion saint-simonienne* (1831); *Correspondance philosophique et religieuse* (1847); *Correspondance politique* (1849); and *Réponse au P. Félix* (1858). A few months before his death he published *La vie éternelle*, a kind of religious and political testament (Paris, 1863).

**ENFIELD**, a town of Hartford co., Connecticut, bordering on Massachusetts, situated on the E. bank of the Connecticut river, and on the New Haven, Hartford, and Springfield railroad, 14 m. N. of Hartford; pop. in 1870, 6,322. It was settled in 1681, and formed part of Springfield, Mass., till 1752, when it was annexed to Connecticut. It is connected with Suffield on the opposite bank of the river by a bridge constructed in 1808, the first one built across the stream in this state. A mile or two below is an iron truss bridge, 1,525 ft. long, erected in 1866 at a cost of \$265,000, over which the railroad crosses to Windsor Locks. A canal  $5\frac{1}{2}$  m. long has been constructed around the falls of the Connecticut in this town, which is intersected by the Scantic and Freshwater rivers, branches of that stream. Enfield contains the villages of Thompsonville and Hazardville, the former being noted for its carpet factory, which contains 141 looms, and manufactures 1,800,000 yards annually, and the latter as the seat of one of the most extensive powder mills in the world. There are also manufactories of sewing machines, ploughs, carriages, sashes and blinds, harness, hats, bricks, distilled spirits, ale, and porter; a savings bank, a trust company, several schools, and four churches. The town contains a community of Shakers, who are especially noted for their culture of garden seeds.

**ENFIELD**, a market town and parish of Middlesex, England, 9 m. N. by E. of London; pop. of the parish about 13,000. It is noted as the

seat of an ancient palace, now half ruined, built in the time of Henry VII., and of the government manufactory of the rifles which take their name from this place. The term "Enfield rifle" does not denote any particular improvement, but the result of a series of improvements on the old musket. (See RIFLE.)

**ENFIELD**, William, an English theologian, born in Sudbury, March 29, 1741, died in Norwich, Nov. 3, 1797. He was a dissenter, and in 1763 was chosen pastor of a congregation in Liverpool, where he remained seven years, and published some devotional works and two volumes of sermons. He was professor of belles-lettres in the academy at Warrington from 1770 to 1783, and was subsequently pastor in Norwich. His "Biographical Sermons on the Principal Characters of the Old and New Testament" are not only valuable as aids to interpretation, but exhibit considerable force of thought and elegance of expression. He published an abridgment of Brucker's "History of Philosophy," and a work entitled "Institutes of Natural Philosophy," and wrote many articles in Aikin's "Biographical Dictionary." He was also the compiler of "The Speaker," a very popular collection of pieces for reading and reciting in schools.

**ENGADINE**, or **Engadin**, or **Valley of the Inn**, a beautiful valley of S. E. Switzerland, near the sources of the Inn, at an altitude varying from 3,500 to 6,100 ft. above the sea, and extending along the banks of the Inn, through the canton of the Grisons, between two principal chains of the Rhaetian Alps, from the Maloja, which separates it from the picturesque valley of Brigell, to the gorge of Finstermünz, on the confines of the Tyrol; length, nearly 60 m.; average breadth between 1 and 2 m.; pop. about 12,000, all Protestants, with the exception of the valley of the Tarasp, which is Catholic. The valley is divided into Upper Engadine, with the watering place of St. Moritz, and the villages of Silva Plana, Samaden, Bevers, &c., and Lower Engadine, with Zernetz, Tarasp, the mineral springs of Scuols, &c. It has more populous villages than any other Alpine valley at so great an elevation, and it has at least 20 important tributary valleys. The tops of the surrounding mountains are inaccessible rocks, and the sides are sometimes covered with glaciers. The valley and the lower part of the mountains are susceptible of cultivation, but are for the most part occupied by forests or used for pasture lands. The climate is so cold and severe that cattle have to be kept indoors during seven or eight months of the year, but during the short summer the valley is visited by large numbers of tourists. The only grain raised is rye, and barley and potatoes seldom mature. The valley was for some time subject to Austria, which lost it in 1623. Most of the male population emigrate at an early age, in order to become rich, and then return to their native valley. Some of the higher Alpine pastures are let

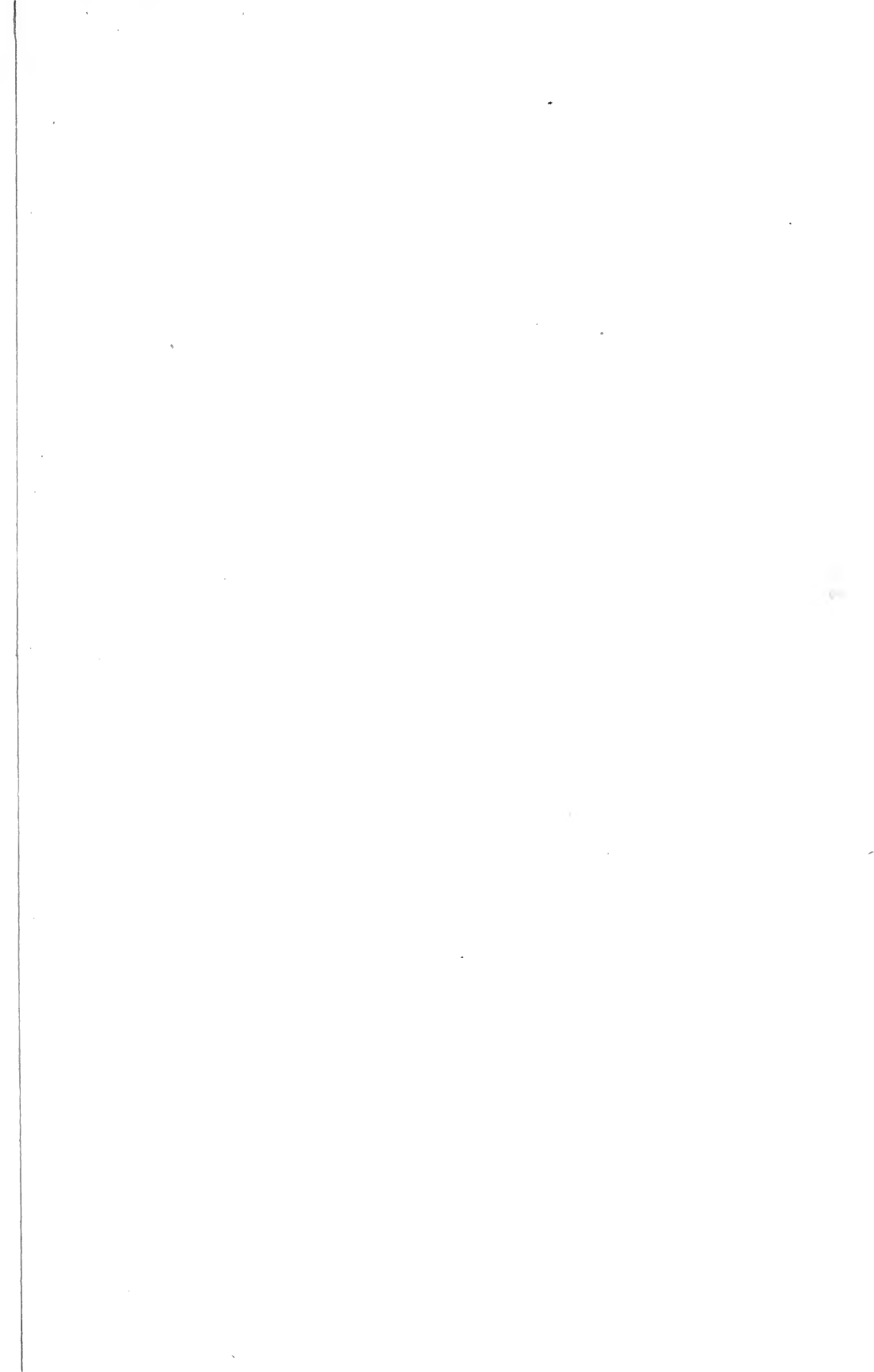

72° 73° 74° 76° 77° 78°

# ENGLAND AND WALES

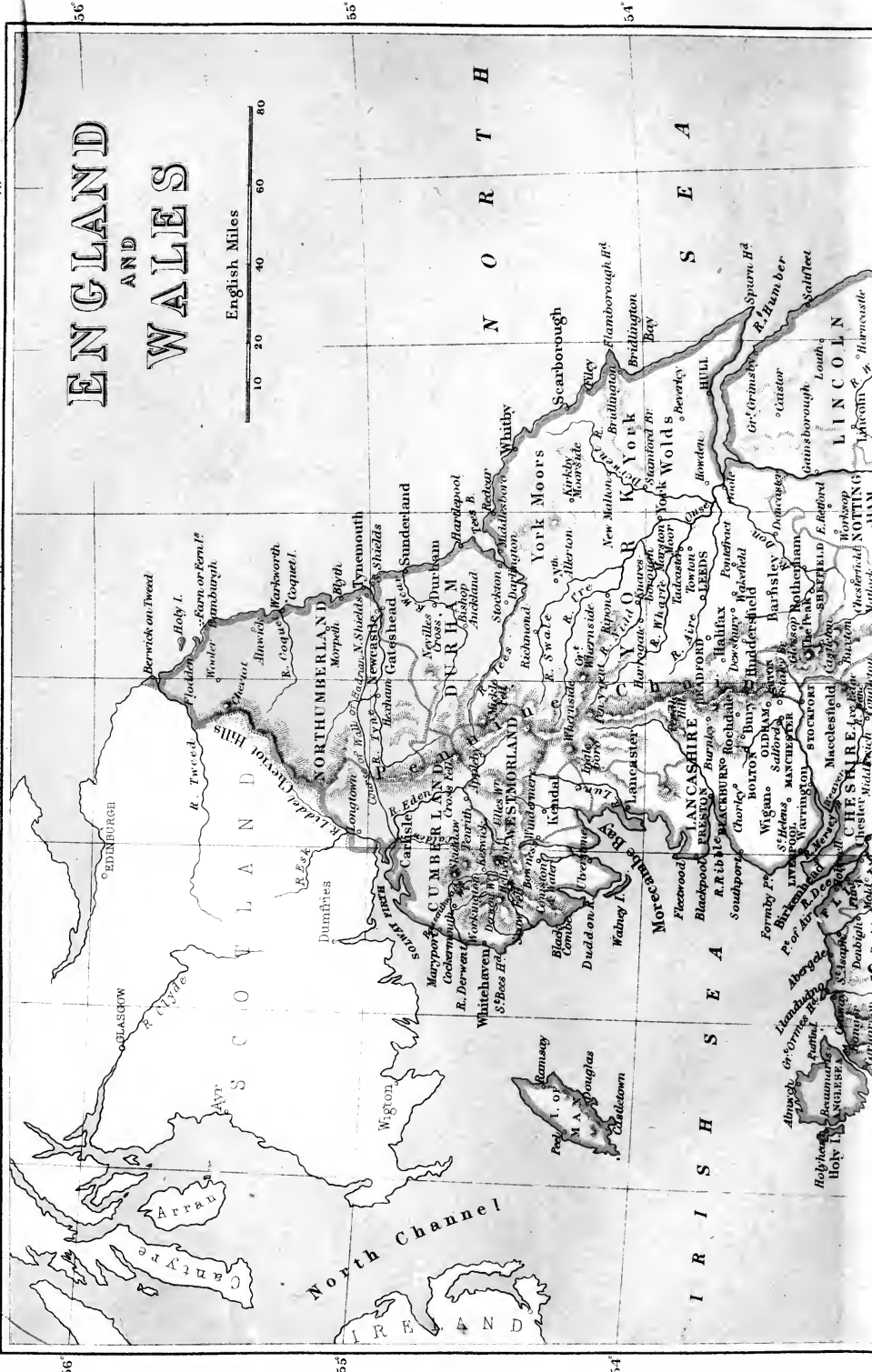
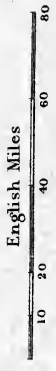

N O R T H

S E A

I R I S H

L I N C O L N

I R E L A N D

56°

55°

54°





every summer to Italian shepherds. The natives speak the dialect called *Romansh*.

**ENGIEN, Louis Antoine Henri de Bourbon, duke d'**, a French prince, of the Condé family, born in Chantilly, Aug. 2, 1772, executed at Vincennes, March 21, 1804. He received an excellent education, served under his grandfather, Prince Louis Joseph, at the outbreak of the revolution in 1789, and accompanied his father and grandfather into exile. He bore arms against revolutionary France in the famous corps of royalist emigrants commanded by his grandfather, and distinguished himself by bravery and humanity to his prisoners. On the disbanding of the corps in 1801 he fixed his residence at a château near Ettenheim, Baden, being impelled to that choice, it is said, by his affection for the princess Charlotte de Rohan, who lived in Ettenheim, and to whom he was perhaps secretly married. Though it does not appear that he took part in any subsequent plots against the first consul, he was generally looked upon as a leader of the *émigrés*, and was suspected of complicity in the attempt of Cadoudal to take Bonaparte's life. The reports of spies gave some color to these surmises, for it appeared that he was frequently absent for 10 or 12 days together, at which times it was supposed that he secretly visited Paris. It was thought that an unknown person who had been seen to visit Cadoudal at Paris, but who afterward proved to be Pichegru, could be none other than the young duke. Anxious to terrify the royalists, and to put a stop to their attempts upon his life, Bonaparte resolved to seize and execute the duke, and

sent Gen. Ordener with 300 gendarmes to make the capture. The soldiers surrounded the château on the night of March 15, 1804, arrested the duke in his bed, and conducted him immediately to Strasburg, whence he was removed on the 18th to the fortress of Vincennes. He had received warning from Talleyrand and from the king of Sweden, through his minister at Carlsruhe, but his escape had been prevented by the delay of the Austrian authorities in forwarding a passport. The prisoner reached Vincennes on the evening of the 20th, and a few hours afterward a court martial, presided over by Gen. Hullin, assembled in the fortress. A mock trial was gone through, and, without the examination of witnesses or written testimony, the duke was found guilty on various charges of treason, and at once led out to execution. His requests to see the first consul and to be allowed a confessor were denied. He was shot by torchlight between 4 and 5 o'clock A. M., in the ditch outside the walls, and his body was thrown, dressed as it was, into a grave which had been dug the day before. Bonaparte and his chief instruments took every pains to justify their conduct, and it has never been known who of them was most guilty.

**ENGLAND** (Lat. *Anglia*; Fr. *Angleterre*), a country of Europe, forming with Wales the southern, larger, and more important division of the island of Great Britain, and the principal member of the United Kingdom of Great Britain and Ireland. This division is bounded N. by Scotland, E. by the North sea, S. by the English channel, separating it from France by distances increasing westward from 21 m. at



Great Seal of England.

the strait of Dover to 100 m., S. W. by the Atlantic, and W. by St. George's channel and the Irish sea, dividing it from Ireland, and having an average width of about 90 m. It lies between lat. 49° 57' and 55° 46' N., and lon. 1° 46' E. and 5° 45' W.; its greatest length N. and S. is 365 m., and its greatest breadth 280

m. Its shape bears some resemblance to a triangle, the apex being at Berwick-on-Tweed, the northernmost point in England, and the extremities of the base at the South Foreland, near Dover, and the Land's End, at the S. W. point of Cornwall. The distance in a direct line from Berwick to the South Foreland is

345 m.; from the South Foreland to the Land's End, 317 m.; and from the Land's End to Berwick, 425 m.; making a total perimeter of 1,087 m., but following the sinuosities of the coast the perimeter is about 2,000 m. The area of England is 50,922 sq. m.; that of Wales 7,398 sq. m. The divisions of England are very ancient, the counties being substantially the same now as they were ten centuries ago, though a few have been made in later times. Each county is subdivided into hundreds, and the hundreds into parishes. London is the metropolis of the United Kingdom, and among the other principal places are Liverpool, Manchester, Birmingham, Leeds, Sheffield, Bristol, Bradford, Stoke-upon-Trent, Newcastle, Hull, Portsmouth, Brighton, Southampton, and York. The following table shows the population of the counties in 1861 and 1871, and the county towns:

COUNTIES.	POPULATION.		COUNTY TOWNS.
	1861.	1871.	
Bedford.....	185,285	146,256	Bedford.
Berks.....	176,103	196,445	Reading.
Buckingham.....	106,597	175,870	Aylesbury.
Cambridge.....	175,950	186,893	Cambridge.
Cheshire.....	505,153	561,181	Chester.
Cornwall.....	369,323	362,098	Bodmin.
Cumberland.....	205,293	220,245	Carlisle.
Derby.....	389,377	380,538	Derby.
Devon.....	584,581	600,814	Exeter.
Dorset.....	158,051	195,544	Dorchester.
Durham.....	509,018	688,045	Durham.
Essex.....	404,044	466,427	Chelmsford.
Gloucester.....	485,502	584,320	Gloucester.
Hereford.....	123,659	125,364	Hereford.
Hertford.....	173,294	192,725	Hertford.
Huntingdon.....	64,297	68,672	Huntingdon.
Kent.....	738,675	847,597	Canterbury.
Lancaster.....	2,428,744	2,818,904	Lancaster.
Leicester.....	237,402	268,764	Leicester.
Lincoln.....	411,977	436,168	Lincoln.
Middlesex.....	2,205,771	2,588,882	Brentford.
Monmouth.....	174,670	195,891	Monmouth.
Norfolk.....	435,422	498,511	Norwich.
Northampton.....	227,727	248,896	Northampton.
Northumberland.....	348,028	386,959	Newcastle-upon-Tyne.
Nottingham.....	298,784	319,956	Nottingham.
Oxford.....	172,266	177,956	Oxford.
Rutland.....	21,859	22,070	Oakham.
Salop (Shropshire).....	240,876	248,064	Shrewsbury.
Somerset.....	444,725	463,412	Bath.
Southampton (Hants, Hampshire).....	481,495	548,897	Winchester.
Stafford.....	746,584	857,393	Stafford.
Suffolk.....	396,271	448,479	Ipswich.
Surry.....	630,685	1,060,270	Guildford.
Sussex.....	363,648	417,497	Chichester.
Warwick.....	561,728	638,902	Warwick.
Westmoreland.....	60,809	65,005	Appleby.
Wilts.....	249,455	257,202	Salisbury.
Worcester.....	307,601	388,848	Worcester.
York.....			
East Riding.....	240,359	260,505	Beverley.
City.....	40,377	48,796	York.
North Riding.....	244,804	291,580	Northallerton.
West Riding.....	1,507,511	1,881,223	Ripon.
Total.....	18,949,980	21,487,688	

Wales, which was incorporated with the English monarchy in the time of Edward I., is divided into 12 counties, with an aggregate population in 1861 of 1,111,795, and in 1871 of 1,216,420. The aggregate population of England and Wales in 1871 was 22,704,108, of

whom 11,040,403 were males and 11,663,705 females. The number of marriages registered in 1871 was 190,015; births, 797,143; deaths, 515,096; the mortality being thus a little less than 22·7 per 1,000, and the natural increase 282,047, or 12·9 per 1,000 nearly. The increase of the population in England and Wales from 1861 to 1871 was 2,637,884, or 13·15 per cent., being an average annual increase of 1·24 per cent.—The most important rivers are the Medway, Thames, Stour, Orwell, Great Ouse, Nene, Welland, Witham, Humber (with its branches the Trent and Ouse), Tees, Wear, Tyne, and Tweed, flowing into the North sea; the Esk, Eden, Lune, Ribble, Mersey, Dee, Severn, Avon, Taw, and Torridge, which empty on the W. coast; and the Tamar, Exe, Frome, Avon (Hampshire), and Southampton water, which flow into the English channel. Many of these have broad estuaries and are navigable by large vessels. The English lakes, though few, are famed for their beauty. The picturesque districts of Westmoreland and Cumberland, in which are Ullswater (9 m. long, and from ¼ to 2 m. wide), Windermere, the largest lake in England (10½ m. long, and from 1 to 2 m. wide), Bassenthwaitewater, Derwentwater, Buttermere, Ennerdalewater, &c., are favorite summer resorts. The sea-coast is much broken, and abounds in fine harbors and roadsteads. On the east are the estuaries of the Medway, Thames, and Humber, and the Wash, into which empty the Great Ouse, Nene, Witham, &c.; on the west the broad Solway frith, between England and Scotland, Morecambe bay, the Bristol channel, and the estuaries of the Duddon, Ribble, Mersey, Dee, and Severn; and on the south Mount's bay, Falmouth harbor, Plymouth sound, Tor bay, the estuary of the Exe, Weymouth bay, Poole harbor, the Solent and Southampton water between Hampshire and the Isle of Wight, Portsmouth and Chichester harbors. Near the entrance of Dover strait into the North sea are the well known anchorage grounds called the Downs, opposite the towns of Deal and Sandwich. The E. coast presents an alternation of sandy beaches and chalk cliffs, hollowed out in many places into caves, and with several high promontories. The Atlantic tides form a strong current, sweeping S. along this coast, and continually wearing away the limestone cliffs and headlands; the encroachments of the sea have already buried large tracts of land. A submarine forest has been traced along a great part of the coast of Lincolnshire. On the sandy portions of the seaboard the opposite phenomenon is observed; portions of land have here been gained from the water, the town of Norwich, which is now near the centre of the E. division of Norfolk, having stood in the 13th and 14th centuries on an arm of the sea. The S. coast, from the South Foreland to beyond Folkestone, is characterized by lofty chalk cliffs, which are continually diminishing in height. It then gradually subsides into Rom-



ney marsh, W. of which the shore becomes alternately precipitous and flat. The W. is by far the most irregular of the English coasts. It is high and rocky as far as Minehead bay on the Bristol channel. North of Wales the shore consists of wasting cliffs of red clay and marl, of peninsulas which were probably once more elevated than now, of abrupt headlands, and toward Solway frith of sands and marshes. The most mountainous part of England lies N. of the rivers Humber and Mersey, and is traversed N. and S. by a range called the Pennine mountains or the northern range, connected with the Cheviot hills on the Scotch border, and terminating in Derbyshire. The highest summits rise to about 3,000 ft. West of this range are the Cumbrian mountains, occupying the central and southern portions of Cumberland, the larger part of Westmoreland, and the N. part of Lancashire. Their highest summits are Scafell (3,229 ft.), Helvellyn (3,055), and Skiddaw (3,022). The Devonian range extends from Somersetshire to the Land's End, and its highest summit, Yestor Beacon, reaches a height of 2,077 ft. Three cross ridges occupy the S. E. part of the kingdom, extending from Salisbury plain, one S. E. to Beachy head, another E. to the E. shore of Kent, and the third N. E. into Norfolk. The famous South Downs, 50 m. long and 5 or 6 m. wide, are in the first, and the Surrey hills or downs in the second, both being celebrated for their sheep pastures. The Malvern hills extend over parts of the counties of Gloucester, Hereford, and Worcester. The Cotswold and Stroudwater hills are in Gloucester, and the Chiltern hills extend from Hertford, across Bucks, into Oxford. Between these ridges lie many beautiful vales; other parts of the country spread out in vast plains, such as the plain of York, which extends from the valley of the Tees to the confluence of the Ouse and Trent, 70 or 80 m., and others abound in rugged and picturesque scenery. Northumberland is largely occupied by moors, which also cover much of Lancashire, Yorkshire, Staffordshire, Cumberland, Westmoreland, and Durham. These are elevated tracts, in most places sterile, heath-grown, or gravelly. Those of the East Riding of Yorkshire alone cover an area of 400 or 500 sq. m. The wolds of Yorkshire, which closely resemble the chalk hills of many other counties, occupy about 500 sq. m.—The distribution of the geological formations through England is closely connected with that of its inhabitants, their industrial pursuits, and physical condition; all which indeed are in great measure controlled by the nature of the mineral productions and of the soil. Nearly all that portion of England lying E. of a line drawn from the mouth of the Tyne in Northumberland in a southerly direction through the towns of Nottingham and Leicester, thence S. W. nearly to Gloucester, and again S. to Bath and S. W. to Exmouth, consists of the upper secondary formations, including the oolite, lias, chalk, and

greensand; and on both sides of the Thames, widening as the formation extends N. along the coast of Suffolk, is the tertiary group of clays and sands, which constitutes the London basin, and rests in the depression of the chalk. Similar strata hide the secondary rocks over a small area about Southampton and the northern part of the Isle of Wight. In Lincolnshire a strip of alluvial skirts the coast, and stretches S., constituting the boggy district of Huntingdonshire and Cambridgeshire. Over this region of secondary rocks the prevailing dip is toward the S. E., so that the lower members of the series are in general met with in passing from the eastern coast westward. They constitute narrow belts, which are traced with great uniformity in their line of bearing, or N. E. and S. W. Thus from Weymouth to the Humber one may continue on that bed of the middle oolite called the Oxford clay, the average thickness of which does not exceed 500 ft. A little further west, from Bridport in Dorsetshire to Flamborough head on the coast of Yorkshire, the topography, rocks, and soil all designate the chalk formation of earlier date; but west of this, on the line from Lyme Regis to Whitby, the limestones of the lias appear in the general order of older rocks in a westerly direction. Over all this region no mines of coal or of metallic ores are found. The easily disintegrated strata present no bold hills, except in the cliffs of chalk abutting upon the coast, but are spread out in elevated plains, and gentle undulations and hills of smoothly rounded outlines. The calcareous nature of the strata secures fertility to the soil; and the region is distinguished for its agricultural character. West of this, occupying a belt not many miles wide, is the manufacturing district of England, made so by the mines of coal and iron ore along its range. They occur at intervals in isolated basins of moderate area, but remarkably productive in coal by the close grouping of the beds and the great depths to which they are carried by the steepness of the dip. These basins are often overlaid in part by the sandstones and marls of the new red sandstone formation, which rests upon the upturned edges of the strata of the coal formation. The marls afford rock salt and strong brine springs, which have long been advantageously worked in Cheshire, and near Droitwich in Worcestershire. Associated with the salt are valuable beds of gypsum. The coal fields are too numerous to be all particularly named. That of Newcastle extends from the N. E. extremity of England to the river Tees, along the coast of Northumberland and Durham; it is traced further S. to Leeds, but this portion has only the lowest beds, which are of little importance. The Yorkshire and Derbyshire extends S. from Leeds to near Derby, and covers in its northern portion a breadth of about 25 m. Some small but very productive coal basins lie S. W. of Derbyshire, of which that near Coventry is the most southern locality

of coal in the midland counties. On the N. W. is the Cumberland and Whitehaven coal field, extending along the coast to the north of Maryport; some of its mines have been worked beyond low-water mark, and the convenience of shipping gives a high importance to their products. The Lancashire coal field lies W. of a range of hills that extends along the borders of this county and Yorkshire, separating the two coal fields by the underlying shales and millstone grit of which they are composed. The strata of the coal formation on the W. side dip toward the west, and the margin of the field in this direction reaches to Prescott, near Liverpool, and extends N. E. toward Colne. A little beyond the southern extremity of the Lancashire coal field is that which supplies the potteries near Newcastle in Staffordshire, and which, with those referred to as lying S. W. of Derbyshire, makes up the central coal district as grouped by Conybeare and Phillips. These include the fields of Ashby de la Zouch and Warwickshire. In the South Stafford or Dudley coal field the coal has been worked in a single bed 30 ft. thick, and at one locality it has reached a thickness of more than 45 ft. The western coal district comprises the mines in North Wales, the island of Anglesea, and Flintshire. The middle western or Shropshire district comprises those of the Cleve hills, Colebrook dale, Shrewsbury, &c.; the southwestern district, those of the Forest of Dean, South Gloucester, and Somerset, on both sides of the river Avon, and the coal field of the S. coast of Wales, bordering the British channel for 100 m. E. and W., and stretching inland toward the north from 5 to 20 m. This field is in convenient proximity to the copper mines of Cornwall, the ores from which are transported to the great smelting establishments on tide water near the coal mines. Much of the coal of this region is semi-anthracite, like that of the Cumberland coal field of Maryland, and some is true anthracite. The latter was first successfully applied upon a large scale to the smelting of iron ores in this district at the Crane iron works. Iron ores abound in the coal measures of this field as well as in many of the others, especially that of Dudley and Wolverhampton, near Birmingham. The same measures also yield fire clay and limestone, and the millstone grit which underlies and holds as in a cup the coal measures furnishes a most durable building stone. Besides the coal measures scattered over the area in which coal and iron are found, and the newer formations which here and there overlie them, there are frequent patches, like islands, of rocks of older date, which have intruded through the carboniferous strata and the later formations above them. These are of granite, syenite, and metamorphic slates. Some are basaltic dikes, and one such of extraordinary extent appears from under the alluvium on the coast of the North sea, near Harwood dale, and is thence traced toward the N. W. across the Tees to the

western part of Durham. It traverses strata of the lias, oölite, the coal measures, and of the metalliferous or mountain limestone of the lower carboniferous group. Its length is from 50 to 60 m., and in some places it is seen only 25 to 30 ft. thick, dipping at a steep angle. The mountain limestone is productive in lead, copper, and zinc ores in three districts of England. Veins of galena near Alston moor in Cumberland traverse adjoining beds of limestone and sandstone, yielding well in the former and poorly in the latter. Others are found in the same county, as also in Durham and Yorkshire, in the upper portions of the valleys of the Tyne, the Wear, and the Tees. Pyritous copper is obtained S. W. of Alston moor, and near Ulverstone beds of red hematite alternate with those of the same limestone. A second district is in Derbyshire and the contiguous parts of the neighboring counties. Zinc blende is economically worked in this district, which also includes the copper mine of Ecton in Staffordshire. The third district is in the N. E. part of Wales, where mines of galena and calamine have long been profitably worked, lying partly in the mountain limestone and partly in older formations. Bordering the coal fields frequently are seen the strata of the old red sandstone and other rocks of the Devonian series; and from beneath these appear the older and lower fossiliferous strata of the Silurian and Cambrian formations; they produce little of economical importance. The metalliferous districts of Cornwall and Devonshire are noticed in the articles upon those counties. The granitic rocks and metamorphic slates, such as are seen in this portion of England, are repeated in North Wales, where the argillaceous slates are worked in the immense quarries near Bangor. The same rocks occur again in the N. W. part of Yorkshire and Lancashire, and are traced through Westmoreland and Cumberland into Scotland. The granite, often disintegrating rapidly, produces the white clay called kaolin, which is used in making fine porcelain; but it affords little good building stone, and there are no important quarries of this rock in England. Good building stone is not readily found in any of the formations; and the want of durable materials is the more sensibly felt because the humid atmosphere produces a rapid disintegration of stone exposed to it. England is deficient in fine marbles and in good iron ores. The best of the latter are the hematites; but those chiefly employed in the immense production of iron are the poor argillaceous ores of the coal formation. For making the excellent cast steel for which English manufacturers are celebrated, the better iron from the magnetic and specular ores of Norway and Sweden is largely imported. The annual produce of salt is over 1,000,000 tons, a large part of which is exported to America.—The climate is subject to considerable variations of heat and cold, and of dryness and moisture, but the winters are not severe for

the latitude, and the heat of summer is often relieved by periods of cool weather. The atmosphere is chilly and damp, and particularly moist in the western counties, but the E. coast is the colder. The mean annual temperature of the S. W. at sea level is about 52°; at Greenwich, 49°; at Penzance, 51·8°. There is thus an increase of mean temperature from N. to S. and from E. to W. July and August are the hottest months; December and January are the coldest, the thermometer in the latter two near London having a mean height of 39·7°. The W. and S. W. are the most prevalent and constant winds, but a blighting N. E. wind blows in April and May on the E. coast, doing great damage to the crops and live stock of Norfolk and Kent. The dry parching character of the latter renders it deleterious to health, but the S. W. winds, which come from the Atlantic, are moist and genial, and it is on their greater frequency that the general salubrity of the climate depends. Notwithstanding the humidity of the climate, the average fall of rain is less than in the northern United States. For the British islands it is given as 32 in., while at Cambridge, Mass., it is stated by Prof. Guyot to be 38 in., and at the Western Reserve college, Ohio, it was found by Prof. Loomis to be 36 in.—The general character of the soil is that of great fertility, and seven ninths of the land is available for cultivation. The principal cultivated crops are wheat, oats, beans, barley, rye, turnips, potatoes, clover, hops, and flax. Few of the forests are extensive, but the country is well wooded, most of the timber being found in small plantations belonging to private individuals. There are some very large forest lands, however, such as the New forest in Hampshire, Dean forest in Gloucestershire, and Sherwood in Nottinghamshire, which are the property of the crown. The principal trees are the oak, ash, mountain ash, fir, beech, sycamore, maple, poplar, elm, larch, pine, chestnut, horse chestnut, and willow. There are not many indigenous fruits; the pear, crab, medlar, wild cherry, bullace, raspberry, blackberry, gooseberry, currant, strawberry, and cranberry are the most important species. Foreign fruits, however, except such as require a powerful sun to bring them to maturity, are found to thrive. Of the small herbaceous plants, besides the common grasses covering the country with verdure which the winter seldom destroys, may be mentioned the daisy, primrose, cowslip, violet, hyacinth, harebell, tamarisk, musk, gentian, foxglove, henbane, hemlock, and nightshade.—Many of the wild animals which formerly inhabited the forests, such as the bear, wolf, wild boar, and wild cat, have disappeared; and the stag, fallow deer, and roe have been preserved only by strict game laws. The other indigenous wild quadrupeds are the fox, badger, polecat, beech and pine martens, otter, weasel, stoat, hedgehog, mole, squirrel, hare, rabbit, dormouse, lemming, shrew, and several varieties of the rat and mouse. More than 270

species of land and water birds have been noticed, of which 20 are birds of prey and 80 are gallinaceous. The bustard seems to be the only bird which has become extinct. Of about 170 species of fish which frequent the coasts, rivers, and lakes, the chief are the herring, pilchard, mackerel, sprat, cod, and salmon. The sea fisheries are chiefly of cod, mackerel, oysters, and lobsters.—The various improvements which modern science has introduced in agriculture are generally adopted in England, and under careful management the land, which once with difficulty supported a population of 10,000,000, now easily maintains more than double that number. The best systems of drainage are employed, not as formerly in marshy grounds alone, but on nearly all farms. Artificial manuring receives due attention, and steeps which a few generations ago would have been thought waste land are now under profitable culture. English husbandry, however, has risen to its present high state very slowly. The farms are small, averaging in England and Wales about 111 acres each, but there are comparatively few land owners, most of the farms being held by tenants at will or by lease. The best tilled counties are those of the E. coast. The capital used in agriculture is about £186,000,000; rent of farms, £60,000,000. Cattle raising is a most important branch of husbandry, and the country has been famous for live stock since the days of Cæsar. Somewhat more than half the arable land is used for grazing, the best pastures being found in Buckinghamshire, Kent, Middlesex, and several of the western and midland counties. In the last are bred good dray horses. Yorkshire is noted for carriage horses, and an excellent breed for farm labor is raised in Suffolk. The English race horse is renowned for speed and beauty. Lancashire is noted for its long-horned cattle; Northumberland, Durham, Devonshire, Herefordshire, and Sussex, for their short-horned breeds; and Suffolk for its duns. Essex, Cambridgeshire, and Dorsetshire are celebrated for good butter; Cheshire, Gloucestershire, Wiltshire, other western counties, and Leicestershire, for cheese. The well known Stilton cheese is made in Leicestershire. The sheep are highly prized for the quality both of their flesh and of their wool. In 1872 there were in Great Britain 9,573,551 acres in grain crops, 3,616,383 in green and other crops, 4,513,451 in clover and grasses under rotation, and 12,575,606 in permanent pasture. There were 2,115,068 horses, 5,624,994 cattle, 27,921,507 sheep, and 2,771,749 swine.—The manufactures of England are commensurate with her greatness in other respects. The most important is that of cotton, which employs more hands than any other in the kingdom, and furnishes about two fifths of the exports. The principal seats of this manufacture are Lancashire, Cheshire, Derbyshire, and Yorkshire. The census of 1871 gives the statistics of the leading textile manufactures of England and Wales as follows:

MATERIALS.	No. of factories.	Spindles.	Power looms.	Operatives.
Cotton.....	2,371	32,013,691	411,836	414,970
Wool.....	1,550	2,193,942	37,356	100,640
Shoddy.....	120	133,793	2,690	8,816
Worsted.....	599	2,068,576	63,445	108,514
Flax.....	155	402,288	3,043	19,816
Silk.....	692	1,117,798	12,185	47,311

The imports of cotton for 1871 were 1,778,139,776 lbs.; exports, 368,234,160 lbs.; retained for home consumption, 1,409,905,616 lbs. The imports of wool for 1871 were 323,036,299 lbs.; exports, 135,089,794 lbs.; retained for home consumption, 187,946,505 lbs. The chief woollen and worsted manufactories are in Yorkshire, Lancashire, and Gloucestershire. The raw material is mostly domestic, though for some years past large quantities have been imported. The great centres of the hardware manufactures are Birmingham and Sheffield, the former having workshops of iron, steel, copper, and brass, and the latter being famous chiefly for cutlery, agricultural implements, grates, fire irons, &c. Linen is manufactured to some extent in Leeds and the counties of Lancaster, Dorset, Durham, and Salop. The silk manufacture made great progress under the tariff of 1826, before which date it was unable to compete with France and Italy. The glove trade of the midland and western counties is important, the principal establishments being at Woodstock, Worcester, Ludlow, Hereford, and Yeovil. The vast number of establishments engaged in the book and newspaper publishing business gives a strong impetus to the production of paper. Distilling is carried on to much smaller extent than in Scotland and Ireland, but the breweries are very numerous, and many of them on the largest scale. The quantity of malt charged with duty in 1872 was 57,308,082 bushels; free of duty, 6,082,284; home consumption, 61,608,569. Among other important manufactures are hats, glass, pottery, soap, lace, &c. Ship building is also a prominent branch of industry. —The commerce of England, until the rise of the trading and maritime power of the United States, had long been without a parallel. Her situation is in the highest degree favorable; the hardihood, industry, and enterprise of her people have turned her natural advantages to account, and there is no accessible part of the world with which she has not established commercial relations. With Ireland she has a trade in grain and provisions in exchange for manufactured goods; from N. Europe she receives timber, iron, flax, hemp, pitch, tallow, potash, and wheat; from central Europe, agricultural produce, silk, linen, lace, gloves, timber, flax, wine, and gin; from S. Europe, wine, brandy, fruit, drugs, silk, &c.; from the United States, cotton, tobacco, rice, grain, flour, and petroleum, the imports thence being considerably inferior in value to the exports; from South America, hides, skins, indigo, cochineal, and bullion; from Asia, tea, coffee, sugar, indigo,

drugs, cotton, piece goods, and ivory; from Africa, drugs, ivory, teak wood, and hides. Manufactured goods are the staples furnished by England in exchange for all these commodities. The following table shows the value of the commerce of the United Kingdom for four years ending with 1872:

YEARS.	Imports.	EXPORTS.		
		Produce and manufactures of the United Kingdom.	Foreign and colonial merchandise.	Total exports.
1869...	£295,460,214	£189,958,957	£47,061,095	£237,014,052
1870...	303,257,493	199,586,522	44,493,755	244,080,577
1871...	331,015,430	223,066,162	60,508,588	283,574,700
1872...	354,693,624	256,257,347	58,831,487	314,588,584

The following table shows the value of the imports of the United Kingdom from and exports to the chief British colonies and the principal foreign countries in 1872:

COUNTRIES.	Imports.	Exports.
<b>BRITISH POSSESSIONS.</b>		
India.....	£33,682,156	£18,471,394
Australasia.....	15,625,866	14,141,673
Canada and North America.....	9,130,919	10,193,277
West Indies.....	5,032,297	2,438,570
Ceylon.....	3,163,153	
Cape and Natal.....	3,717,465	3,705,554
Straits Settlements.....	3,505,114	2,420,072
Guiana.....	1,362,977	
Hong Kong.....		2,872,673
Gibraltar.....		1,189,023
All other possessions.....	4,102,906	5,123,461
Total British possessions.....	£79,372,853	£60,555,997
<b>FOREIGN COUNTRIES.</b>		
United States.....	£55,663,948	£40,736,597
France.....	41,503,444	17,265,839
Russia.....	24,320,338	6,609,224
Germany.....	19,231,873	31,618,749
Egypt.....	16,455,731	7,218,063
Netherlands.....	13,108,473	16,211,775
Belgium.....	13,211,044	6,499,062
China.....	13,246,092	6,624,511
Spain.....	9,316,820	3,614,448
Sweden and Norway.....	9,091,307	3,411,280
Brazil.....	9,450,249	7,519,719
Turkey in Europe.....	2,894,998	5,184,252
Italy.....	4,159,161	6,557,538
Peru.....	4,211,723	2,570,293
Portugal.....	4,119,363	2,310,202
Chili.....	5,591,783	3,147,843
Spanish West Indies.....	5,231,543	3,042,257
Denmark.....	3,618,337	2,056,390
Asiatic Turkey.....	2,545,531	2,504,891
Greece.....	1,998,153	
Argentine Confederation.....	1,902,839	3,911,419
Western Africa.....	1,895,656	
Philippine Islands.....	1,376,055	
Austria.....	911,607	1,471,118
Uruguay.....	1,416,933	1,517,733
Roumania.....	1,044,406	
Colombia.....		3,150,337
Japan.....		1,961,327
Mexico.....		843,186
All other countries.....	7,513,739	7,599,307
Total foreign countries.....	£275,320,771	£195,701,950
Total imports and exports.....	£354,693,624	£256,257,347

The six principal articles of import into the United Kingdom, with their value in 1870-'72, were:

ARTICLES.	1870.	1871.	1872.
Cotton, raw.....	£53,469,768	£55,907,070	£58,380,670
Corn and flour.....	84,169,644	42,502,252	51,228,816
Sugar, raw and refin'd	17,184,868	18,188,417	21,187,601
Wool, sheep and othr	15,512,598	17,940,639	18,523,350
Silk manufactures....	15,171,291	8,397,324	9,141,573
Tea.....	10,097,619	11,635,644	12,938,143

The six principal articles of export are :

ARTICLES.	1870.	1871.	1872.
Cotton manufactures	£71,410,181	£72,821,411	£80,164,155
Woolen and worsted manufactures	26,821,217	88,283,112	38,493,411
Iron and steel.....	24,083,000	26,124,134	35,996,167
Linen manufactures....	9,435,835	9,741,664	10,956,761
Coals, cinders, and culm.....	5,506,890	6,267,047	10,442,321
Machinery.....	5,286,508	5,966,941	8,201,112

The total number and tonnage of sailing and steam vessels that entered and cleared at the ports of the United Kingdom in 1872 are exhibited in the following statement :

COUNTRIES.	ENTERED FROM.		CLEARED FOR.	
	No. Vessels.	Tons.	No. Vessels.	Tons.
<b>BRITISH POSSESS'NS.</b>				
Channel Islands.....	1,623	243,650	1,609	226,160
East Indies.....	968	877,944	1,126	1,075,081
Australia.....	242	225,716	411	390,955
North America.....	1,840	1,302,972	1,599	1,073,544
West Indies.....	639	211,978	504	174,529
British Guiana.....	107	47,090	206	76,802
All other possess'ns	350	265,656	1,278	727,215
<b>Total British possessions.....</b>	<b>5,769</b>	<b>3,130,006</b>	<b>6,738</b>	<b>3,744,236</b>
<b>FOREIGN COUNTRIES.</b>				
<b>Russia:</b>				
Northern ports....	3,399	1,024,406	2,563	771,892
Southern ports....	1,224	824,029	370	204,195
Sweden.....	4,441	1,092,573	2,721	743,376
Norway.....	4,018	824,258	3,100	677,427
Denmark.....	1,566	205,373	4,041	700,530
Germany.....	8,019	2,557,829	9,156	2,542,679
Holland.....	5,369	1,471,067	4,305	1,139,221
Belgium.....	4,155	1,124,646	3,050	814,075
France.....	15,041	2,769,573	14,769	2,616,901
Portugal.....	827	213,254	983	271,167
Spain.....	2,873	843,373	2,353	665,776
Spanish W. Indies.	413	153,370	532	235,530
Italy.....	656	277,854	1,311	763,345
Austrian territories.	49	40,532	312	154,222
Greece.....	197	110,131	157	63,384
Turkey.....	533	262,504	467	251,223
Egypt.....	593	424,698	633	542,513
United States.....	2,726	2,430,741	2,652	2,602,737
Mexico.....	106	37,592	84	34,844
Brazil.....	654	247,720	950	433,043
Peru and Chili.....	384	243,550	690	522,193
Argentine Republic.	170	83,801	257	132,356
All other countries.	1,541	713,715	2,040	814,745
<b>Total foreign countries.....</b>	<b>58,959</b>	<b>17,835,409</b>	<b>53,150</b>	<b>17,741,374</b>
<b>Total foreign and colonial.....</b>	<b>64,728</b>	<b>21,015,415</b>	<b>64,888</b>	<b>21,485,610</b>
<b>Coasting trade.....</b>	<b>186,394</b>	<b>18,099,150</b>	<b>136,130</b>	<b>17,922,597</b>
<b>Aggregate.....</b>	<b>201,122</b>	<b>39,114,565</b>	<b>201,013</b>	<b>39,403,507</b>

Of the total number of vessels that entered, 36,822 of 14,173,289 tons were British, and

27,906 of 6,842,126 tons were foreign; and of those that cleared, 37,149 of 14,545,801 tons were British, and 27,734 of 6,939,809 tons were foreign. The above statistics are for the United Kingdom. For England, the entrances were 49,150 vessels of 15,331,948 tons in the foreign, 4,821 of 2,582,485 tons in the colonial, and 91,831 of 11,105,245 tons in the coasting trade; clearances, 49,340 vessels of 15,662,006 tons in the foreign, 5,743 of 3,134,855 tons in the colonial, and 100,613 of 11,789,499 tons in the coasting trade. In addition to the above, 1,501 vessels of 107,556 tons in the colonial and foreign trade, and 1,344 of 114,354 tons in the coasting trade, entered the Channel islands and isle of Man, and 1,510 of 86,235 tons in the foreign and colonial, and 707 of 77,211 tons in the coasting trade cleared. The total number of vessels registered for England under merchant shipping acts in 1872 was 20,097, with a tonnage of 4,510,556, including 17,290 sailing vessels of 3,290,025 tons, and 2,807 steam vessels of 1,220,531 tons. The total number of vessels built at ports of England, exclusive of vessels built for foreigners, was 687 of 236,871 tons, of which 345 of 34,159 tons were sailing, and 342 of 202,712 tons steam vessels. The ocean steam navigation of England is incomparable, and her lines of steam packets may be said to perform the mail service of the world. Steam vessels of iron are now extensively built.—The means of internal communication are superior to those of any other country. It is about a century since the English began to make good roads, though turnpikes were set up 100 years earlier. The total length of all roads in England and Wales, exclusive of paved streets and roads in towns, is about 100,000 m.; of the latter, 30,000. The canals of England are next in importance to those of Holland, and were commenced in the last century. The first railway was begun in 1825 and opened in 1830, and 6,621 m. of lines had been constructed in the United Kingdom in 1850, being at the rate of 265 m. per annum. At the end of 1860, 10,433 m. were open; at the end of 1872, 15,814. These lines had a total capital paid up at the end of 1872 of £569,047,346, had conveyed 422,874,822 passengers, besides season-ticket holders, and had received during the year £51,304,114. Of these lines there were in England and Wales 11,136 m., in Scotland 2,587 m., and in Ireland 2,091 m. The number of post offices in the United Kingdom at the beginning of 1873 was 12,200. The gross revenue of the post office department in 1872 was £5,208,922; cost of management, £2,754,764. The postal savings banks received £7,567,034, and paid out £5,402,644. The post office department was authorized by act of parliament, July 31, 1868, to buy up all the telegraph lines, and to charge the public a uniform rate irrespective of distance. A supplementary act was passed in 1869 making the telegraph a government monopoly like the post office. The purchases

were made late in 1869, and possession obtained in February, 1870, when there were 2,933 telegraph offices. At the beginning of 1873 there were 5,400 offices, of which 3,593 were postal offices, and 1,807 railway telegraph offices. The latter slightly decreased in 1870-'71, while the postal offices were greatly multiplied. Up to June, 1871, about £930,000 had been expended, besides the purchase money; 5,000 persons were employed, and the net receipts for about 14 months had been £798,580, at a current expense of £470,000. The investment of the government was thought to amount to a capital of £7,500,000, upon which it is believed that a reasonable interest is returned.—The public institutions of charity, of learning, of the arts, of education, and of religion are in great number and of high repute. Every considerable town has its hospitals, many of which are liberally endowed, its free schools, mechanics' institutes, &c. The principal cities possess galleries of arts, and several have valuable libraries. Compulsory provision for the poor has long been established in England. The whole country is divided into poor-law unions, over which are guardians elected by the rate payers. On Jan. 1, 1873, there were 736,201 outdoor paupers in receipt of relief; indoor paupers, 154,171. The total amount expended by the poor-law boards in England and Wales during the year ending Jan. 1, 1873, was £8,007,403; a decrease from the preceding year in actual amount, and a decrease in rate upon the average of several years. The number of charitable institutions other than schools in London alone in 1874 was about 600.—England has done much for the cause of education, but not so much as should have been done by so old, wealthy, and humane a nation. Among the higher institutions of learning are the universities of Oxford, Cambridge, and Durham; University college and King's college, London (the last two founded for the purpose of cheapening and popularizing academical instruction); college of preceptors, London; Owen's college, Manchester; Manchester New college; Queen's colleges, Birmingham and Liverpool; St. David's college, Lampeter; royal agricultural college, Cirencester; besides good foundation schools at Winchester, Eton, Manchester, Great Berkhamstead, Warrington, Shrewsbury, Birmingham, Tunbridge, Westminster, Highbate, Bedford, Ipswich, Repton, Rugby, Harrow, and London. The great public schools of Eton, Westminster, Harrow, Winchester, St. Paul's, the Charterhouse, and merchant tailors' school, are of the highest reputation, and have educated many of the distinguished men of England. Public education has made much progress within the last quarter of a century, though a great difference exists in the prevalence of elementary knowledge in different parts of the country. The uneducated are found in greater numbers among the mining and manufacturing populations than in the agricultural portions of the kingdom. The latest returns show that

one fifth of the adults in England are unable to write their names. By the school law of 1870 parliament ordered that sufficient accommodation in public elementary schools should be provided for all resident children, and that all children whose parents are unable to pay for their education shall be educated at the public expense, while the school boards shall have power to compel parents to give their children between the ages of 5 and 13 the advantages of education. The condition of the elementary schools in England and Wales subject to government inspection is shown in the following statement:

	Year ending Aug. 31,	
	1870.	1871.
Estimated population at the middle of the year.....	22,090,163	22,704,108
Number of schools, <i>i. e.</i> , of departments under separate head teachers, inspected:		
Receiving annual grants.....	14,565	15,484
Simply inspected.....	688	776
Total.....	15,253	16,210
Accommodation:		
In annual-grant schools.....	1,878,584	2,012,679
In simple-inspection schools.....	53,982	72,785
Total.....	1,932,566	2,085,414
Number of scholars in schools receiving annual grants:		
Present at examination:		
Day scholars.....	1,434,766	1,509,288
Evening scholars.....	77,918	86,279
Total.....	1,512,684	1,595,567
Average number attending:		
Day scholars.....	1,152,389	1,231,484
Evening scholars.....	73,375	83,457
Total.....	1,225,764	1,314,991
Number of scholars in schools simply inspected:		
Present at examination:		
Day scholars.....	39,117	48,959
Evening scholars.....	5	178
Total.....	39,122	49,167
Average number attending:		
Day scholars.....	16,592	24,656
Evening scholars.....	7	.....
Total.....	16,599	24,656
Number of teachers:		
Certificated.....	12,467	13,195
Assistant.....	1,262	1,251
Pupil-teachers.....	14,304	16,941

A large part of this work is under the care of the established church and other religious organizations, the state doing but a small proportion. The first education grant, of £20,000, was made in 1833. In 1872 the grants were raised to £1,551,560, of which about one tenth was spent in administration and building. This grant was an increase over that of the preceding year of £512,936. The total amount of education grants from 1833 to 1872 has been £14,553,262. The subject of national education is of increasing interest in England. The

question of religion causes the chief difficulty. The rivalry of different religious organizations has stimulated them to great exertions for education, but a strong sentiment urges the separation of public education from all religious control. For a more complete account of the system of education in England, see EDUCATION.—The established religion is that of the church of England, which will be treated in a separate article. The dissenters constitute some of the most respectable religious bodies in the world. They consist of Presbyterians, Independents, Baptists, Friends, Methodists, Unitarians, Bible Christians, Moravians, and some others. The Presbyterians, Methodists, and Baptists are severally divided into a number of sects. The Roman Catholics are not numerous, but among them are many old and wealthy families. The Jews are few, but since July 23, 1858, when they were permitted to sit in parliament, they have enjoyed all civil rights.—The government is a limited hereditary monarchy, the supreme power being vested in a king or queen and ministry, and a parliament composed of lords and commons, the former sitting chiefly by hereditary right and the latter by popular election. A previous knowledge of English history being required for a comprehension of the changes and present state of the English constitution, we shall refer the reader for an account of the latter to the concluding part of this article. The following tables show the revenue and expenditure of the United Kingdom for the year ending March 31, 1873 :

REVENUE.

Customs.....	£21,033,000
Excise.....	25,785,000
Stamps.....	9,947,000
Land tax and house duty.....	2,337,000
Income tax.....	7,500,000
Post office.....	4,820,000
Telegraph service.....	1,015,000
Crown lands (net).....	375,000
Military and naval, extra receipts and proceeds of old stores sold.....	889,490
Amount received from the revenues of India on account of British troops serving in that country.....	996,373
Allowance out of profits of bank of England per act 24 Victoria, c. 3.....	138,573
Miscellaneous receipts.....	1,772,329
<b>Gross income.....</b>	<b>£76,608,770</b>

EXPENDITURES.

<b>Debt:</b>		
Interest and management of the permanent debt.....	£22,136,893	
Terminable annuities.....	4,539,547	
Interest of exchequer bills.....	128,912	£26,804,852
<b>Charges on consolidated fund:</b>		
Civil list.....	£406,910	
Annuities and pensions.....	303,139	
Salaries and allowances.....	100,269	
Courts of justice.....	644,657	
Miscellaneous charges.....	108,239	
Telegraph sinking fund.....	11,740	1,574,954
<b>Supply services:</b>		
Army.....	£14,466,700	
Navy.....	9,543,000	
Army purchase commission.....	946,500	
Miscellaneous civil services.....	10,175,135	

Supply services, continued:	
Customs and inland revenue.....	2,594,302
Post office.....	2,634,130
Telegraph service.....	841,766
Packet service.....	1,133,058
	<u>42,324,641</u>
Total ordinary expenditure.....	£70,714,448
Army expenses provided for by annuities.....	308,000
Total expenditure.....	<u>£71,022,448</u>
Excess of income over total expenditure.....	£5,586,322

The public debt, March 31, 1873, was:

Funded.....	£726,584,423
Estimated capital of terminable annuities.....	33,558,560
Unfunded.....	4,829,100
Total.....	<u>£764,972,103</u>

The total debt at historical periods during the past century has been :

PERIODS.	Capital of debt.	Interest and management.
1775 } American war.....	£128,583,635	£4,471,571
1784 } .....	249,851,628	9,451,772
1793... Beginning of French wars.	239,350,148	9,208,495
1817 } Consolidation of English and Irish exchequers..	840,850,491	32,038,191
1836.....	757,638,516	29,143,517
1837.....	784,972,103	26,804,853

The army estimates for 1873-'4 called for a total expenditure of £14,416,000, and gave the regular army at 125,000 men, including 63,000 home forces; besides militia 139,000, yeomanry 15,000, volunteers 161,000, first reserve 10,000, and second reserve 20,000. The desertions from the regular forces in 1872 were 4,000. The navy estimates for 1873-'4 called for an expenditure of £9,704,985, and gave the following numbers of seamen and marines :

For the fleet:		
Seamen.....	34,000	
Boys.....	7,500	
	<u>41,500</u>	
Marines.....	14,000	
For the coast guard (ashore).....	4,300	
Indian service.....	1,200	
Total.....	<u>61,000</u>	

The total naval force in September, 1872, was: steam vessels, including 60 iron-clads, 167 in commission and 197 in reserve and building; coast-guard tenders, 25; sailing vessels, 38 in commission and 106 in reserve and building; total tonnage, 677,883; number of guns 5,080. The government has fine dockyards at Deptford, Woolwich, Chatham, Sheerness, Portsmouth, Devonport, and Pembroke, a naval academy at Portsmouth, a military academy at Woolwich, and a military college at Sandhurst.—The judicial system of England until recently comprised four superior courts: the high court of chancery, the court of exchequer, the court of king's (or queen's) bench, and the court of common pleas. The court of king's bench was the supreme court of common law, and took cognizance of both civil and criminal causes, and to it could be removed by writ of error the judgments of all other English courts

of record. It consisted of a chief justice and four other justices. The court of common pleas likewise consisted of five justices, and took cognizance of civil cases between subjects. The court of exchequer consisted of a chief baron and four other barons; it was both a law and an equity court, trying all revenue questions and many other cases. The judges of these three courts were called the fifteen judges of England. In August, 1873, by an act to take effect in November, 1874, the superior courts of England were united into a supreme court of judicature, divided into two parts, a high court of justice and a court of appeal. The judges of the old courts are retained in the new one, which is presided over by the lord chancellor. The forms of administering justice are simplified, while the former distinction between law and equity is not recognized. The high court is divided into sections named after the old courts. The court of appeal consists of the chancellor, the two chief justices, the chief baron, and master of the rolls, with not exceeding nine ordinary judges. By act of parliament in 1846, and by several subsequent acts, a system of county courts has been formed, giving increased facilities for the prompt and inexpensive collection of small debts. The judges of these courts are appointed by the lord chancellor, and must not exceed 60 in number. Demands not exceeding £50 are brought before these courts, the judges of which determine all questions whether of law or fact, unless a jury be summoned, which is done at the request of either party. The number of jurymen is five. A court of general quarter sessions of the peace is held four times a year in every county, its jurisdiction extending to all felonies and trespasses, but the capital cases generally are remitted to the assize. The criminal code, which for a long time was excessively severe, has been greatly improved. The commitments and convictions from 1869 to 1873 were as follows:

YEARS.	COMMITTED.			Con- victed.
	Men.	Women.	Total.	
1869.....	15,722	3,596	19,318	14,340
1870.....	14,010	3,568	17,578	12,953
1871.....	12,640	3,629	16,269	11,946
1872.....	11,467	3,384	14,859	10,862

Most of the convicts sentenced for long terms of detention were formerly transported to penal colonies, or confined on board hulks, but prisons are now established at home capable of receiving all. There are in England 121 county, borough, and "liberty" prisons (*i. e.*, prisons for the districts so called). The commitments for 1872 to reformatory schools were 1,445; the number detained at the end of the year was 5,356, 4,322 males and 1,034 females. The average annual cost per head was, boys £18 19s. 9½*d.*, girls £17 16s. 3¼*d.* There were also 2,050 commitments to industrial schools

schools in the year, and detained at the close of the year 7,120, 5,443 boys and 1,677 girls. The police force of England and Wales in 1870 was 26,441, and the cost of maintaining it during the year was £2,182,522.—The history of England begins shortly before the commencement of the Christian era, when Cæsar first invaded the island, landing near Deal or Walmer (55 B. C.). Britannia and Albion were the names by which it was known to the Romans. The inhabitants, called Britons, were of Celtic race, kindred to the Gauls. The Phœnicians had known the island, and so had the Carthaginians and Massilians; and all of them are supposed to have traded with it directly or indirectly, the Phœnicians especially, for tin. Yet at the time of Cæsar's invasion little was really known concerning the country, and for a long period afterward it was regarded as cut off from the rest of the world. He made little impression on it, and his invasion probably met with more resistance than is commonly supposed. Augustus proposed an expedition to Britain, but never attempted it. Caligula also threatened an invasion without executing it. Claudius began the work of real conquest, A. D. 43. During the next 40 years the conquest of south Britain was completed, many generals being employed, including Aulus Plautius, Vespasian, Suetonius Paulinus, and Agricola. The main divisions of the country were Britannia Romana, embracing England and Wales, which had been entirely subdued, and Britannia Barbara, which at first included all the country to the north of the wall of Hadrian, but later only what was to the north of the wall built by Antoninus, from the frith of Clyde to the frith of Forth. This region defied all the efforts of the Roman arms. The other was in a very flourishing condition, and at a later period was divided into five provinces, named Britannia Prima, Britannia Secunda, Maxima Cæsariensis, Maxima Flaviensis, and Valentia. Christianity had been early introduced, and before the close of the 3d century a regular hierarchy was established. The country suffered with the rest of the empire from the invasions of barbarians, and was abandoned by the Romans before the middle of the 5th century. The Britons then became independent, and displayed much energy and spirit in contending with the invaders. They were less successful in their endeavors to establish a body politic, and the island was distracted by contentions and civil wars. The disturbed state of the country was favorable to the incursions of the Picts and Scots, tribes like the Britons of Celtic origin, when a few Saxons, said to have been exiles, arrived in the isle of Thanet. They were but 300, and were led by two brothers commonly called Hengist and Horsa. They were, it is probable, on a piratical excursion. The story that they came by invitation probably originated in the fact that other Saxons were subsequently invited to Britain. The British chiefs hired their visitors as soldiers, according



to a not uncommon custom. They chastised the Scottish invaders, and when the Saxon leaders proposed sending for more of their countrymen, in order that their defensive measures might be more extensive, the proposition was readily received, and numbers of Saxons, Angles, and Jutes arrived in the country. At first these strangers proved good friends to the Britons, but when they had conquered the other barbarians they took Britain for their reward. This, however, was not effected without a bloody contest, in which the Britons evinced great bravery, and at one time are said to have expelled their false allies. The history of these times is little better than fable, and the very names of Hengist and Horsa are perhaps as mythical as those of Romulus and Remus. The most that is known is, that certain Germanic invaders subdued the greater part of Britain, driving the Celtic natives into Wales and adjoining parts, and laid the foundation of that England which has occupied so large a space in the history of the world for so many centuries. These invaders appear to have belonged substantially to one race, but they had strong points of difference, which were particularly prominent as between Saxons and Angles. One effect of this German conquest was to cause Britain to revert to heathenism; but in the pontificate of Gregory the Great the work of Saxon conversion commenced, under the guidance of the monk Augustin. Seven independent kingdoms, jointly called the heptarchy, had gradually been formed by the conquerors since the year 449, viz.: Kent, Sussex, Wessex, Essex, East Anglia, Mercia, and Northumbria. The last consisted of the two prior kingdoms of Deira and Bernicia, united by King Ethelfrid in 593. There was almost constant war among them, and two or more were frequently united under one head (in which case the monarch of the united kingdoms was called a *bretwalda*), until finally Egbert, king of Wessex, about 827, conquered them all, and first styled himself king of England. In his reign the Northmen first appeared in force in England; and it shows the vitality of the old British race that numbers of them joined the invaders. There had been previous attacks, but this was the most serious; it was unsuccessful, and the Britons who had risen were punished severely. These invasions were constantly renewed, the Northmen and Danes being the terror of all peoples who could be reached from the sea. Large portions of England fell into their hands. Much of Alfred's reign (871-901) was passed in contests with them. The fortune of these wars was various, but even the victories of the Anglo-Saxons cost them dear; yet it is probable that the general result was good, and that the infusion of new blood into England prevented the country from degenerating, and gave to it a new life. Much of what is called Saxon is of Danish origin; but the Danes and Saxons were substantially of the same race, the differ-

ences being in favor of the former. A Danish dynasty was established in the early part of the 11th century, and the name of Canute, or Knut, is high on the list of England's sovereigns. The Saxon dynasty was restored in 1042, in the person of Edward the Confessor, on whose death the throne was conferred on Harold, son of Earl Godwin, a great Saxon statesman. But an event was impending over England which was to color her history for ever. The Normans, descendants of those Northmen who had settled in Neustria (N. W. France) and given it the name of Normandy, had obtained considerable influence in England in the Confessor's time, and were indeed the leading race of the West. William, duke of Normandy, claimed the throne of England through his great-aunt Emma, mother of Edward the Confessor; the latter favored his claim, although compelled to leave the crown to Harold. Neither William nor Harold had a strictly legitimate right to the throne, but Harold had the support of the English nation, and William assembled a powerful army to enforce his claim. The support the duke received from his own subjects was reluctantly given, but the promises of spoil attracted many adventurers from different parts of Europe, so that he was enabled to land 60,000 men in England. Harold, who had just defeated an army of Norwegian invaders, met the Normans at Hastings, where he lost his life and his kingdom, Oct. 14, 1066. William's victory was complete, and the Normans and other adventurers soon became masters of all England. Saxons and Danes were involved in common slavery. The victor introduced the feudal system into England. It is probable that the extent of the Norman spoliation has been much exaggerated, but that the natives were reduced to a state of political bondage admits of no doubt whatever. The very name of Englishman was made odious. A foreign rule was established over England, and it was not until seven generations had passed away that the distinction between Norman and Saxon was nearly obliterated. It did not disappear altogether till a much later period, but it ceased to influence legislation about the end of the 13th century. The Norman line gave three sovereigns to England: William I., William II., and Henry I. The death of the last, in 1135, was followed by the reign of Stephen of Blois, his nephew, and by the wars between that king and the adherents of the old dynasty. Henry I. left an only daughter, Matilda, married first to the emperor of Germany, and then to Geoffrey, earl of Anjou, by whom she had that prince who became Henry II. of England in 1154. England suffered terribly in the contest between Stephen and Matilda, the rightful heiress to the crown, who was supported by a powerful party. Henry II. became king in consequence of an arrangement with Stephen, who had lost his only son Eustace, but the treaty was really the work of the

barons, who had risen to high power during Stephen's reign. The young king was the founder of the royal family of Plantagenet, which held the English throne 330 years. He had Saxon blood, his great-grandmother being a Saxon princess, descended from Alfred. There have been few abler monarchs than Henry II. He was duke of Normandy and count of Anjou, and, having married Eleanor of Aquitaine, was also duke of Aquitaine and count of Poitou. Maine belonged to him. He undertook the conquest of Ireland. Had it not been for his dispute with Becket, and domestic troubles at a later period, he might apparently have conquered the whole of France. The crusades, too, were prejudicial to his interests. He died in 1189, and was succeeded by Richard I. (Cœur de Lion). The English are proud of this chivalrous king, yet he was a Frenchman, could not speak the language of the island people, and kept out of England whenever he could. His brother and successor, John, who ascended the throne in 1199, was one of the weakest and most wicked of kings; he is one of the few men, eminent either from talent or position, who, after having been long regarded as monsters, have had nothing said in their favor by modern writers. His French rival, Philip Augustus, was an able statesman. Their contests were ruinous to John as a continental sovereign. Normandy, Brittany, and Anjou were lost, and the English Plantagenet had little more than England for his dominion. His continental possessions were all to the south of the Loire. The insular Normans were thus separated from the continental Normans, and were compelled to have the same interests with the mass of the people. From this came the series of events that led to the concession of the great charter, June 15, 1215. John was involved in disputes with Pope Innocent III., to whom he afterward resigned his kingdom, and received it back on terms which made him a vassal. In a contest with France his troops shared in the loss of the battle of Bovines. The barons called Louis, the son of the king of France, to their aid, and he at first was successful; but evincing a partiality for his countrymen, he lost ground, many of his first supporters joining John, who was about to fight him, when he died, Oct. 19, 1216. He was succeeded by his eldest son, Henry III., then nine years old. The government was conferred on the earl of Pembroke, who compelled the French to make peace and to leave the country. On Pembroke's death power passed to the hands of Hubert de Burgh and the bishop of Winchester, but the former was soon compelled to resign it. The reign of Henry III. is the longest in English history save that of George III., and it was passed in constant troubles. The favor shown to foreigners caused much irritation. There were frequent disputes with the barons, which led to important consequences. Under the lead of Simon de Montfort, earl of Leices-

ter, the barons defeated the king at Lewes in 1264, and took him captive; and under Leicester's rule, the first English parliament in the modern sense was assembled in 1265. But in the same year the party of Leicester was overthrown, and the royal authority seemed firmly established. Prince Edward, the son of Henry, who had effected this, set out to join the last crusade. Henry's weakness encouraged his enemies, and the country was relapsing into confusion, when he died in 1272. Edward I. ascended the throne without opposition, and proved himself a good sovereign, founding permanent legal institutions which have ever since been spoken of with respect. He conquered Wales, annexed it to England, and conferred the title of prince of Wales on his son and heir, which has ever since been borne by the eldest son of the sovereign of England. He sought to conquer Scotland, and at one time appeared to have succeeded; but the resistance of the Scotch, first under Wallace, then under Comyn and Fraser, and finally under Bruce, saved their country from becoming an English dependency. Edward was involved in a war with France, which had seized Guienne, one of the few remaining possessions of the English on the continent, but it was restored under papal mediation. His wars made him dependent on parliament, the power of which was much increased in his reign, the commons first sitting in a separate chamber in 1295. This has been considered the first session of the commons, though perhaps that distinction belongs to the parliament summoned by Simon de Montfort under Henry III. Edward violated the great charter, and for a time showed every disposition to reign arbitrarily; but the opposition he experienced was not to be overcome, and he gave way before it. While marching to meet Bruce in Scotland, he died, July 7, 1307. His successor, Edward II., was unable to comprehend or to accomplish his father's designs. He was governed by favorites, whose insolence provoked the barons, by whom the chief favorite, Gaveston, was put to death in 1312. The king was induced to lead a great army to Scotland in 1314, which was completely defeated at Bannockburn, an event that established the Scottish nation and the throne of Bruce. At the instance of Edward's queen, Isabella of France, parliament deposed the king, who was soon afterward murdered, September, 1327. The government was now nominally in the hands of Edward III., a boy of 15, but in reality it was wielded by Isabella and Roger Mortimer, her paramour. These rulers were unpopular, and their unpopularity was increased by a treaty which they made with Scotland in 1328, renouncing all claim to superiority over that country. Mortimer was able and unscrupulous, and the young king conspired against him. The queen mother and her lover were seized, and the latter was executed. The reign of Edward III. is one of the most brilliant in Eng-

lish history. He repressed the lawless men who had had their way during his father's reign. Aiding Balliol in an attempt to obtain the crown of Scotland, he won over the Scotch the victory of Halidon Hill, July 19, 1333. He set up a claim to the crown of France, in right of his mother, which led to that rivalry of France and England which has endured to this day. He had numerous allies on the continent, and he led an army into France in 1338, which accomplished nothing. The great naval victory of Sluis was gained by the English in 1340. Troubles with parliament and want of money impeded the war, and it was not till 1346 that the battle of Crécy was won by the English. Calais was afterward taken, and the king then made a truce with the French. While he was absent, an army raised by his wife defeated the Scotch at the battle of Neville's Cross, and captured their king, David Bruce. A naval war with the Spaniards followed, and the latter were defeated in a great battle. The pestilence that ravaged the world in the 14th century appeared in England in 1349. The renewal of the war with France led to the battle of Poitiers in 1356, in which Edward, prince of Wales, known as the Black Prince, defeated King John of France, and made him prisoner. In 1359 Edward III. again invaded France, and besieged Rheims, because he wished to be crowned king there. The next year peace was made between the two countries, Edward renouncing all claim to the French crown, but receiving large portions of French territory and an immense sum of money. The French king, finding himself unable to fulfil the terms of the treaty, went back to England a prisoner, and there died. The prince of Wales, from Guienne, interfered in the affairs of Spain, and won the battle of Najera in 1367, in behalf of Pedro the Cruel, and over the French, who under Du Guesclin were aiding Henry of Trastamare. The expense of this war made the prince unpopular, and his last days formed a miserable contrast with his early career. He died in 1376, a year before the death of his father. The latter years of the king were also embittered by failure in France, and by disputes with parliament. Much was done in this reign toward the development of English industry, and some constitutional questions were settled. The new king, Richard II., son of the Black Prince, was only 11 years old, and a regency was appointed. The war with France languished. The peasantry, headed by Wat Tyler, rose in rebellion. The young king showed both tact and courage on this occasion, and gave greater promise of ability than was justified by his career. A war with Scotland led to no results. The ambition of the king's uncle, the duke of Gloucester, caused internal troubles. The king wasted on frivolous pleasures money that had been granted him for other purposes, and he completed his unpopularity by making a long truce with France, and by marrying the daughter of

Charles VI., a child of seven years. Gloucester sought to avail himself of this unpopularity, but was seized, imprisoned, and put to death, and his party was destroyed. Parliament stood firmly by the king. Two of his supporters were the dukes of Hereford and of Norfolk, and they quarrelling, the king banished them both, the first for ten years, and the second for life. Hereford was son of John of Gaunt, the duke of Lancaster, and cousin of the king, and when on his father's death the king seized his cousin's estates, the new duke of Lancaster returned to England, and rapidly levied a force that placed him at the head of the country. He compelled the king to resign the crown, and assembled a parliament, which made him king on the ground of his descent from Henry III. According to the received ideas of succession, he had no claim to the throne, which, failing Richard and heirs of his body, belonged to the earl of March, descended from the duke of Clarence, third son of Edward III., the new king being son of Edward's fourth son. The reign of Henry IV. began Sept. 30, 1399. Richard was imprisoned and is supposed to have been murdered in Pontefract castle, but nothing is certainly known of his fate. Henry's reign was one of much interest. The followers of Wycliffe had become very numerous, and the king's father, John of Gaunt, had supported Wycliffe; but the son proved a firm adherent of the church of Rome, and consented to an act for the punishment of heretics passed in 1401, and under which much cruelty was perpetrated for two centuries. The Lancastrian dynasty, by allying itself with the church, postponed the reformation for four generations. The reign of Henry IV. was short, but eventful. In a war with Scotland, the English won the victory of Homildon Hill. The rebellion of Glendower in Wales was successful for many years, and that chief was never formally subdued, though finally forced to remain quiet. A rebellion headed by the earl of Northumberland broke out in 1403, but the victory of the king at Shrewsbury established his power. Other rebellions followed this, and the conspiracies were numerous. The French had insulted the English frequently, and Henry IV. was on the point of renewing the war, when illness compelled him to refrain; and soon after he died, March 20, 1413. His son and successor, Henry V., put down the Lollards with a vigorous hand, and renewed the war with France. In the summer of 1415 he reduced Harfleur. The battle of Agincourt, Oct. 25, 1415, was won by the English against great odds. The war was continued, and in 1420 it was settled by a treaty that Henry V. should marry Catharine, one of the daughters of Charles VI., and become heir to that king. Fortunately for England, which by its success would have been probably reduced to the condition of a province of France, this plan failed. Henry died Aug. 31, 1422, when apparently about to realize his scheme. He left but one child, a boy of nine months, who

became Henry VI., and was soon the king of a large part of France, his French grandfather dying soon after his father. The king's uncle, the duke of Bedford, carried on the war, and the English were mostly victorious over the French and their Scotch allies. A variety of events, however, among which the exploits of Joan of Arc are the most remarkable, led to a change in the fortunes of the contest, and the French had in 1451 recovered all their country except Calais and two other small places. Henry VI. proved to be a man of much amiability, but deficient in intellect and vigor. During his minority the court was the scene of intrigues and contentions; and when he had arrived at manhood, and married Margaret of Anjou, daughter of René, titular king of Sicily, Naples, and Jerusalem, that able princess became the real head of the state. The conflicts of parties were increased in fierceness, partly from the throwing of so many public men back upon England, who had lost all they had seized in France. That contest which is known as the war of the roses, or the contentions of the houses of York and Lancaster for the crown of England, commenced about 1452. Richard, duke of York, a descendant of the second son of Edward III., was the legitimate heir to the throne. Had Henry VI. been an able monarch, Richard's claims would have been of little practical importance; but the weakness of the king and the fierceness of the party contests united to concentrate men's attention upon the duke, who had many strong points of character, and had served his country well in France and Ireland. He had married Cecily Neville, daughter of the earl of Westmoreland, a near connection of the earls of Salisbury and Warwick, two of the greatest nobles of the realm. The duke expected to succeed quietly to the crown on the king's death, as Henry had no children for many years after his marriage; but in 1453 Prince Edward was born. The king was reduced by illness to a state of imbecility, and York was made protector; but when Henry in 1455 recovered his intellect, he resumed power, and showed such favor to the duke's enemies that the Yorkists assumed arms, and a civil war began which did not fully end until 40 years later. The first battle was fought at St. Albans, May 22, 1455, and was won by the Yorkists, or party of the white rose. The king was now in their power, and acceded to all the demands of York, who became protector again on the return of Henry's illness. The queen was less submissive, and nearly succeeded in her attempts to destroy the opposition chiefs. War was resumed in 1459, with various fortune. After the battle of Northampton, July 10, 1460, it was arranged that Henry should remain king for life, but that York should succeed him. Margaret resisted, and on Dec. 30 defeated the Yorkists at Wakefield. York and his young son, the earl of Rutland, and his chief supporter, Salisbury, were put to death. The

Yorkist claim now passed to Edward, earl of March, the duke's eldest son, a youth of 19, superior to his father in intellectual qualities, but his inferior in virtue and humanity. Edward marched against one of the Lancastrian armies and defeated it, and then proceeded to London, where the people and some of the parliament acknowledged his claims. He was proclaimed king, March 4, 1461; and so prompt were his movements that he met the Lancastrian army at Towton, a few miles from York, the 29th of the same month (Palm Sunday); 100,000 men joined battle, and after the most sanguinary conflict that ever occurred on English ground, victory declared for Edward IV. Margaret renewed the contest with French and Scottish aid, but was beaten at Hexham, May 15, 1464. Henry fell into his rival's hands, and was imprisoned in the tower. The power of the Yorkists being established, they fell to quarrelling among themselves. The Nevilles, at whose head stood the earl of Warwick, claimed more than the king could grant, and so became enemies of the royal house. The king's marriage with Elizabeth Woodville, widow of Sir John Grey, gave offence to Warwick. The duke of Clarence, a brother of the king, married the eldest daughter of Warwick, to the disgust of the monarch. In 1469 the Nevilles headed a rebellion, being aided by Clarence, and the king at one time was their prisoner. Released from confinement, Edward put down another rebellion, and conferred high favors on Clarence and Warwick; but the quarrel was renewed, and failing to seize the king, the rebel chiefs fled to France, where Warwick, under the mediation of Louis XI., joined the party of Margaret of Anjou. Landing in England, and proclaiming Henry VI. king, Warwick was everywhere successful, and Edward fled to Holland; but in a few months he returned, and was as successful as Warwick had been. In four weeks he entered London, having been joined by his brother Clarence. The battle of Barnet was fought April 14, 1471, and the Lancastrians were defeated, Warwick and his brother Montague falling on the field. On May 4 Edward again defeated the Lancastrians at Tewkesbury, Prince Edward, son of Henry VI., being taken prisoner, and at once put to death. Margaret of Anjou was made prisoner, and sent to the tower, where her husband perished soon afterward. Edward was no more disturbed by the Lancastrians, but the dissensions at his court caused him great trouble. His brother Clarence he put to death. He invaded France at the head of a large force, but Louis XI. bought peace of him, and he returned to England. He died in 1483. His successor, Edward V., was not quite 13 years old. The court was divided into two parties, the one consisting of the relatives of the young king on the maternal side, and the other of the old nobility. Richard, duke of Gloucester, the king's uncle, an able and ambitious prince,

seized the reins of government, was made protector, put to death several of the monarch's relatives and supporters, and finally made himself king. Edward V. and his brother, the duke of York, were placed in confinement, and soon disappeared, the general belief being that they were murdered by Richard's orders. The reign of Richard III. was brief, and much disturbed by conspiracies; he had offended the Yorkists, and had not conciliated the Lancastrians. A coalition was formed against him, at the head of which stood the earl of Richmond, who was the great-great-grandson of John of Gaunt, founder of the house of Lancaster, being descended from the earl of Somerset, son of that prince by Catharine Swynford, his mistress. Somerset had been legitimated by parliament, but cut off from the line of succession to the crown. On his father's side Richmond belonged to the Welsh family of Tudor, his grandfather, Owen Tudor, having married Catharine of Valois, widow of Henry V. of England. Thus Richmond had no legitimate claim to the throne; but party exigencies overcame everything, and to satisfy the Yorkists it was agreed that Richmond should marry Elizabeth, eldest daughter of Edward IV. The first effort of the conspirators failed, and the duke of Buckingham, the chief of them in England, was beheaded. In 1485 they were more successful. Richmond landed in Wales at the head of a small force, marched into England, encountered Richard at Bosworth, Aug. 22, and defeated him, the king falling in the battle. The crown that he wore in the action was placed on the head of Richmond, who was hailed as Henry VII. This monarch, first of the Tudor line, bore himself as chief of the Lancastrian party, and depressed the Yorkists whenever he could do so, though he felt himself compelled to marry the princess Elizabeth. His reign was disturbed by many conspiracies, and by the appearance of pretenders to the crown. The first of these was Lambert Simnel, who personated the earl of Warwick, son of the last duke of Clarence, and undoubted heir to the crown, failing children of Edward IV. The Irish supported this pretender, who was the son of an English baker, and he was aided by the duchess dowager of Burgundy, a sister of Henry IV., and notorious for her hatred of Henry VII. At the head of a miscellaneous force of Irish and foreign soldiers, the Yorkist leaders landed in England, and had they received any considerable English support would probably have succeeded; but they were left to fight unaided, and were totally defeated at Stoke, June 16, 1487. Among the slain was the earl of Lincoln, next to Warwick the chief member of the house of York. Simnel was taken prisoner and made a scullion in the king's kitchen. Another pretender was Perkin Warbeck, said to have been the son of a Tournay trader, but who claimed to be Richard Plantagenet, duke of York, second son of Edward IV., a claim which has

found strong defenders. Henry regarded him as a much more important character than Simnel, and foreign potentates treated him as if they believed in his claim. James III. of Scotland gave him one of his relatives in marriage, and marched an army into England to aid him. But all his efforts failed. A Cornish insurrection was put down by the king, at the battle of Blackheath; yet when the pretender entered Cornwall he was regarded as king, was joined by a large force, and laid siege to Exeter. On the approach of the royal army, however, he fled, and subsequently surrendered on condition that his life should be spared. Flying a second time, he again gave himself up on the same terms, but was set in the stocks, and made to read a confession that he was an impostor. Consigned to the tower, he sought to escape, and was hanged at Tyburn (1499). Henry at the same time caused the earl of Warwick, the last survivor of the legitimate male descendants of Edward III., to be put to death, on a groundless charge of conspiracy with Perkin. With these proceedings closed the contest between the houses of York and Lancaster, in the complete prostration of the former, though the latter was represented by an illegitimate member, who was not even descended from Henry IV., the founder of Lancastrian royalty. The last years of Henry VII. were more peaceably passed, and he became a powerful sovereign at home, while his influence was great abroad. Under him England entered upon her career of maritime discovery. His master passion was avarice. He pretended to make war on France, but only that he might obtain money from his subjects, and then sold peace to the French monarch. He depressed the power of the high nobility in various ways. The law that no man should be held guilty of treason for adhering to the king *de facto* was passed in his reign. He died April 21, 1509. Henry VIII., his successor, was his second son, the first, Arthur, having died before his father. Arthur had married the princess Catharine of Aragon, daughter of Ferdinand and Isabella, and on his death his father had procured a dispensation from the pope allowing the marriage of Catharine and his second son, which was not solemnized until after the accession of Henry VIII. He was frequently engaged in hostilities with foreign countries, and the great victory of Flodden was won by one of his generals over James IV. of Scotland, husband of his sister Margaret. His policy was the result of his passions. That he was troubled concerning his marriage with his brother's widow, after that marriage failed to produce sons that could arrive at maturity, is easily believed, as he was singularly superstitious; but it required his passion for Anne Boleyn to give his scruples much force. Had the court of Rome aided him to a divorce, he would have remained a Catholic; but that court refusing this, he threw off his allegiance

to the pope, and became head of the church in England. He was six times married, and two of his wives were beheaded and two were repudiated. Much that was severe in Henry's treatment of his wives has been attributed to his desire to have heirs, the wars of the roses having made English sovereigns, statesmen, and people very sensitive on the subject of the succession. Henry interfered much in continental politics, and the European balance-of-power theory dates from his time. In his reign the scaffold was occupied by victims from every class of society, the number of whom, however, has been considerably exaggerated. The highest classes were the greatest sufferers, the king being impartial in the selection of his victims. He died Jan. 28, 1547, and was succeeded by his only son Edward VI., whose mother was Jane Seymour, Henry's third wife. Edward was in his 10th year, and the government was placed in the hands of a council of regency, the principal members of which were the earl of Hertford, the king's uncle, soon created duke of Somerset and protector, and Archbishop Cranmer. In this reign the church of England was established, and the nation placed on the Protestant side in the struggle then going on in Europe. In the contests for power that took place at court, Somerset was finally worsted, and then beheaded. Dudley, duke of Northumberland, into whose hands all power passed, caused his fourth son, Lord Guildford Dudley, to marry Lady Jane Grey, great-granddaughter of Henry VII.; and when Edward VI. died, July 6, 1553, the duke made Lady Jane queen, to whom Edward had been persuaded to bequeath the crown. Her reign lasted but ten days, and her party was quickly dispersed. Mary, eldest daughter of Henry VIII., ascended the throne, and behaved mercifully toward most of those who had sought to prevent her succession. Northumberland and others were executed, but Lady Jane and her husband were spared till the next year, when they were executed, in consequence of the lady's father, the duke of Suffolk, having taken part in Wyatt's rebellion. Suffolk also was executed. Mary effected a reconciliation with Rome, and gave her hand to Philip II. of Spain. This marriage led to war between England and France, and an English army joined the Spanish force that invaded France, and took part in the battle of St. Quentin. The French succeeded in an attack on Calais, the loss of which shortened Mary's life. She was a devout Catholic, and caused Cranmer, Latimer, Ridley, and about 300 other Protestants, to be burned. Her death, which occurred Nov. 17, 1558, left the throne to Elizabeth, who, somewhat against her own inclinations, sided with the Protestants for obvious reasons of policy. Her reign, which lasted nearly 45 years, is one of the most brilliant in English history. Sagacious in the selection of her counsellors, though her occasional folly gave them great trouble, she triumphed over her en-

emies, and raised her kingdom to the first place in Europe. She ruled over Scotland in fact, and put the sovereign of that country to death after having held her in captivity nearly 19 years. The Huguenots of France and Henry IV. received aid from her, and but for the assistance which she gave the Dutch they would have sunk under the power of Spain. She invited the Turks to join her in attacking the pope and Philip II.; and over both those potentates she achieved a great triumph in 1588, when the Spanish armada was destroyed. Some of the greatest names in the literature of England belong to the Elizabethan age. The enterprise of Englishmen led them to circumnavigate the globe, to attempt colonization, to extend commerce, and to commence the trade with India. Elizabeth had not much to do directly with these things, but she was the central figure of a great nation in a great age, and all that was accomplished by her subjects increased the splendor of her glory. She died March 24, 1603, and with her terminated the Tudor dynasty, after an existence of nearly 118 years. She was succeeded by James VI. of Scotland, the son of her victim Mary Stuart, and first king of England of the Stuart line, who inherited the English crown in virtue of his descent from Margaret Tudor, eldest daughter of Henry VII., who had married his great-grandfather, James IV. The new king was hailed with much satisfaction by the English. The question of the succession to the throne had been one of vital interest since the successive wives of Henry VIII. had proved so unfruitful. Rulers and people alike had been deeply moved by the danger of a disputed succession, and from the death of Edward VI. to that of Elizabeth only two women of the main line were in existence, and for 44 years only one woman, Elizabeth herself. The anxiety that was felt for the marriage of Elizabeth was owing to this dread; so that when the sceptre passed quietly to the hand of a monarch who was descended from their ancient kings, who was not yet at the period of middle life, and who was the father of several children, a weight was taken from the English mind. Had James been a man of common sense, he might have preserved this popularity, and laid deep the foundations of his dynasty; but he was a pedant and a tyrant, without the courage which is necessary to maintain a tyranny. His person, his manners, and his actions were all against him; and before he had reached London his popularity began to decline, and was quickly exhausted. He commenced that course of policy which was destined to cause his house to become extinct in exile. The divine right of kings, so abhorrent to reason and to English ideas of government, was the basis of his conduct. He perpetually claimed higher power than any Plantagenet or Tudor, but he invariably abandoned his ground when he was resisted. His first parliament, 1604, in reply to his assertion that all their priv-

ileges were derived from him, asserted in full, and in the plainest language, all those principles for which the English constitutionalists contended as facts not to be questioned. Then began that civil contest which lasted down to 1689 in full force, and which was not utterly at an end till 1746. The foreign policy of James was as vicious as his home policy, and England became of less account in the European world than a second-rate German or Italian principality. James I. died in 1625, and was succeeded by his son Charles I., a monarch who had some elegant tastes, but who apparently could not conceive of any obligations on the part of a king to his subjects. He did not put forward his pretensions so offensively as his father, but he adhered to them with a courage and a tenacity that were utterly unknown to James. He set deliberately to work to introduce into England the system of government that prevailed in France, to do in England and Scotland what the Austro-Burgundian princes had done in Castile and Aragon. He had been educated in England from his early childhood, had good faculties, and had by his assent to the petition of right expressly agreed not to rule arbitrarily, for a full and solid consideration paid into his hands. Yet for 11 years (1629-'40) he called no parliament, and England was ruled as despotically as France; and had all his instruments been prudent and able men, it is possible he would have succeeded in his design. His chief instruments were Wentworth, afterward earl of Strafford, and Laud, archbishop of Canterbury; the former one of the ablest men in an age singularly prolific in able men; the latter equally distinguished for his narrowness of mind. These two men seem to have been associated only that the wisdom of the one might be confounded by the folly of the other. Laud gave precedence to ecclesiastical tyranny, whereas Wentworth, if he had had entire management of affairs, would have established political despotism, whence religious uniformity would soon have followed. It is very doubtful whether the people could have been stirred up to the fighting point if their religious sentiments had remained without serious disturbance until their political rights had been totally subverted. Laud sought to fasten the English church polity on Scotland, which was met by deep and determined resistance on the part of the Scotch. War between the Scotch people and the English government followed, and Charles was compelled to call a parliament, April, 1640. Thus were all Wentworth's sagacious plans set at naught. The parliament, known in history as the short parliament, lasted but a few days, when it was dissolved. Six months later assembled the famous long parliament, which the king's necessity forced him to call. This parliament punished the king's tools, and forced him to admit that it should not be dissolved without its own consent. It then proceeded to divest the king of much of his power, demanding

among other things the control of the militia. The parliamentary party went beyond the limits of the constitution in their desire to preserve the constitution; but their justification is to be found in the purpose and acts of the king, and in his incurable falsehood. The political leaders of 1640-'42 never counted upon the king's death or deposition, and at no time was it out of his power to have reigned in strength and peace, on the sole condition that he should rule as a constitutional sovereign. It was natural that Charles should refuse to part with power that was legally his; and it was equally natural that the parliament should refuse to allow it to remain in his hands. Both parties appealed to arms, and what is known as the great civil war began in the latter part of 1642. At first fortune favored the king, but his wrong-headedness rendered him unable to profit therefrom. Gradually the radical party in parliament gained strength, and, under the lead of Vane, Cromwell, and others, rose to power. Cromwell was everywhere victorious in the field. Parliament was "purged" of all who showed any disposition to treat with the king. The army became the source of all power. The king was tried, condemned, and executed. Ireland was conquered by Cromwell, who was almost equally successful in Scotland. The battle of Worcester, Sept. 3, 1651, crushed the royalists for nearly nine years. In 1653 Cromwell dissolved the parliament by force, and was master of England for five years, ruling the country more wisely than it had been ruled by Charles or James, but still with an iron hand. He would have ruled constitutionally if he could, but by him the English would not be so ruled. He wished to become king, but this the army would not allow, for it was composed of sincere republicans. Yet England then occupied the highest place she had ever known in the world's estimation; one in striking contrast with that which she had held during the 40 years of the rule of James I. and Charles I. The subjection of Ireland had now been consummated. After Cromwell's death, in 1658, dissensions broke out, and the military and civil republicans quarrelled. Richard, the son of the great protector, who had succeeded his father, but had little ability, resigned, and thus was prepared the way for the restoration of the Stuarts, effected by Gen. Monk in 1660. The reign of Charles II. dates in fact from that year (May 29, when he entered London), though in law it dates from the day of his father's decapitation. The change was prodigious. The austere Puritans were succeeded by profligate cavaliers. The Puritans had insisted upon ruling the nation into righteousness, and had caused that reaction which ended in the foulest licentiousness. Many of the reforms effected by the long parliament remained permanent. That body had swept away the court of star chamber, the high commission court, and the council of the north, all tremendous instruments of royal tyranny, and not one of these

was it possible to revive. The nation had gone forward, and could not go backward, even under the reaction which caused sensible men to welcome back the profligate king. Had Charles been ambitious, he might have accomplished what his grandfather, his father, and after him his brother were unable to do; he might have established despotism in England, at least for a time. But, though one of the ablest members of his family, he was singularly destitute of those feelings which ordinarily are found in monarchs. He loved his ease above all things, and if he could get pleasantly through the 24 hours, he was quite willing that other men should do so. He had many of those qualities which are popularly attributed to his grandfather, Henry IV. of France; but he probably laughed at his ancestor's daring in the field. His vices were of the popular kind, and such as men are ready to forgive in kings. From the 11th to the 30th year of his age his life had been passed amid civil disputes, wars, wanderings, and intrigues, and in poverty; and he had contracted from this experience a horror of everything like danger or business. Happen what might, he is reported to have said, he would not again go on his travels. From the personal selfishness of this easy voluptuary England derived almost as much good as from the tyranny of John or the cowardice of James I. He was content to rule as much through parliament as could be expected from a monarch under such little restraint. Several times, when persuaded to venture upon some despotic act, he was ready to give way when he found the opposition resolute. He retreated from the ground assumed in his declaration of indulgence, and so weakened the royal power. His popularity soon declined, mainly on account of his foreign policy. England's honor, it may be said, was gibbeted with Cromwell's body at Tyburn. An unnecessary war with the Dutch produced much disgrace. The triple alliance with Sweden and Holland for a brief interval stayed the course of Louis XIV., but this was the solitary act of the kind that reflects honor on this reign. The king soon became the tool and pensioner of France. His forces assisted in the war on Holland made by Louis XIV. The unpopularity of this course, and the internal misgovernment of the cabal ministry, created a great change in English opinion, and finally assistance was sent to the Dutch. The peace of 1678 was followed by the excitement caused by the alleged popish plot, and for a time the king was almost as unpopular as his father had been in 1640. Parliament after parliament was elected, met, set itself in decided opposition to the government, and was dissolved. The leading object of the opposition was the exclusion of the duke of York, Charles's brother, from the line of succession; and even to this the king would finally have consented rather than fight. But a reaction set in and saved him from the last disgrace; and when the Oxford parliament was dissolved, in

1681, the king found himself hardly less powerful than he had been in 1660. He never called another parliament, but was able to govern without one. The conspiracies that were formed by the whigs (the names of whig and tory had their definite political commencement in 1680) were detected, and many of the conspirators were punished. Others, men of whom the government wished to be rid, such as Russell and Sidney, were executed. Few kings have been more powerful than Charles II. was during the last three years of his reign, yet some marked advantages had been obtained by the constitutionalists, which have endured. The *habeas corpus* act of 1679 was among the greatest triumphs of the liberal party, not only in itself, but because it furnished a point of union between whigs and tories; for in the next reign it was found that the tories, even when most servilely loyal, could not be prevailed upon to repeal that act. Charles II. died suddenly in February, 1685. His brother James II. came to the throne without opposition, and for a brief period was popular. Though an open and avowed Catholic, he was beloved by the priesthood of the church of England, which indeed had saved his inheritance in the days of the exclusion bill. Had he been content with persecuting the dissenters and whigs, and with destroying much of the civil liberty of his subjects, it is not unlikely that he would have made himself as powerful as Henry VIII. had been; but he wished to reestablish the ascendancy of his own church, which could not be done without overthrowing the Anglican church, and despoiling the aristocracy of much of their property; and thus he united church, aristocracy, and all the intelligent part of the people against him. The parliament which he summoned was most servile, but it could not satisfy the king. He was bent on the establishment of a despotism, and the destruction of the constitution in church and state. He punished Monmouth's rebellion with a vindictiveness to which there are few parallels in history. The king prorogued parliament in November, 1685, and that body never met again. For three years he governed despotically, and a perpetual contest was waged between him and his people; and the vigor displayed on the popular side shows how well established was the English constitution. The king at first sought the aid of the church against the dissenters, and received it until the church found he meant its own destruction, together with that of all other forms of Protestantism, when it revolted, in spite of its passive obedience doctrines. He then sought an alliance with the dissenters against the church, and though some of them were ready to aid him, the great majority remained true to the constitution. By the autumn of 1688 the king was opposed by almost all classes of his subjects, and could not procure the services of even third-rate lawyers in an age proverbial for the baseness of its legal men. William,



prince of Orange, had watched the contest closely. He was the king's nephew, son of his sister Mary, and had married the king's eldest daughter Mary, heir apparent to the British crown. It is not probable that he cared much for the liberties of England, for he was the chief of that party in Holland which was opposed to the existing constitution, a polity in its spirit not unlike that of England; but he was firmly opposed to Louis XIV., and desired to have the aid of England in thwarting his schemes; and James was the pensioner and ally of Louis, and so would remain so long as he should persist in governing England illegally. While Mary of Orange stood next in succession to James, her husband could not do much in opposition to that king; but he let it be known that his sympathies and those of his wife were with the constitutionalists. James had married for his second wife Mary Beatrice, a princess of the house of Este, and from this union had proceeded four children, all of whom had died. It seems to have been taken for granted that this couple were to have no more children, and that in due course James would be succeeded by his daughter Mary; but in 1687 the queen was declared to be pregnant, and on June 10, 1688, was born that prince who was afterward known as the pretender. This incident precipitated matters, for the opinion was almost universal in England that a supposititious child had been placed in the position of heir apparent to the crown. On June 30, 1688, William was invited to invade England at the head of an army. This invitation was signed by the earls of Shrewsbury, Devonshire, and Danby, by Lord Lumley, by Henry Sidney and Admiral Russell, and by Compton, bishop of London; and it was accepted. A variety of circumstances favored the undertaking, and on Nov. 5 William landed at Torbay, at the head of a well appointed army, 15,000 strong, composed of men of several nations. At first the people were slow to join him, and after advancing as far as Exeter he talked of returning to his ships; but men of note now began to repair to his standard, and it was found that James had no hold even on the great army which he had established in defiance of law. He was deserted by those upon whom he ought to have been able to rely, even his daughter Anne joining his enemies. He gave way to terror, hastened to undo all he had done, and fled. Brought back to London, he fled a second time, and reached France, whither he had sent his wife and son. All England was in the hands of William and his friends. The convention parliament that assembled conferred the crown on William and Mary, and in its declaration of right placed the vindication of the act on the ground of the "undoubted inheritance of Englishmen," the entire movement being conservative in its character, and not one of innovation. The events of 1688-9 are known as the English revolution, but it would be more correct to call them

the close of that revolution; for the contest that had commenced with the coming of the Stuarts to the throne, and which had lasted for 86 years, was virtually closed on the day that William and Mary were proclaimed king and queen of England. For almost two centuries the government of England has been constitutional without question, a circumstance totally without parallel in the history of great nations. If we except the rebellions of 1715 and 1745, that country has been the scene of no serious outbreak against established authority for six generations. Faults there have been in both government and people, but not greater than are to be found in the corresponding annals of other European nations; while in no other country of the old world has the good that England has known had an existence. Liberty and law have gone hand in hand together, each sustaining the other, mutually imparting a portion of their spirit. Moral, intellectual, and material progress through six generations has placed England foremost among nations, and left her in some important respects without a rival. The greatness of England, her moral power, and in no small degree her literature, and the fact that she is the mother of nations destined perhaps to excel herself, are all due to the happy settlement that was effected in 1688-9, which was the completion by one set of patriots of what other patriots had initiated or forwarded. William III. found his new throne anything but an agreeable seat, but it enabled him to combat Louis XIV. with ultimate success, though the war that England declared against France in 1689 was marked by many reverses. It was terminated by the peace of Ryswick in 1697. Ireland was subdued almost as completely as she had been by Cromwell. Several conspiracies were formed against the new government, but they all failed. Mary died in 1694, and left William sole monarch. The freedom of the English press dates from 1695. Most of the legislation of this reign was liberal, and would have been more so if William's wishes could in all cases have prevailed. Much of the evil of those times grew out of religious intolerance, and William was singularly free from bigotry, though few men have been more devout. The toleration act, which has been said to illustrate most strikingly the peculiar vices and the peculiar excellences of English legislation, was adopted in 1689. During William's reign the bank of England was established (1694), and the modern system of finance introduced. He entered into two partition treaties with Louis XIV. to dispose of the immense dominions of the Spanish branch of the house of Austria, Charles II. being without heirs of his body. Louis violated the second treaty in 1700, and William would have made war on him, but circumstances prevented; and there was every prospect that the entire Spanish monarchy would pass to Philip of Anjou without a serious struggle,

when Louis threw the whole British nation into a rage by acknowledging the son of the exiled James II. king of Great Britain, James dying in 1701. William was preparing for vigorous war when he died, March 8, 1702. The year before his death he had the satisfaction of seeing the finishing stroke put to the work of the revolution. In 1613 Elizabeth Stuart, daughter of James I., had wedded the elector palatine, Frederick V. The youngest child of this marriage was a daughter, Sophia, married to Ernest Augustus, first elector of Hanover. As early as 1689 William had been desirous of entailing the British crown on this lady, and the house of lords unanimously agreed to an amendment of the bill of rights to that effect. This bill declared that after the decease of both William and Mary, the crown should descend to the heirs of the body of Mary; or if she died without issue, to Anne of Denmark and the heirs of her body; or if she also was without issue, to the heirs of the body of William of Orange. The commons unanimously rejected the amendment. While the two houses were conferring on the subject, a son, afterward known as duke of Gloucester, was born to the princess Anne. Neither house would give way, and the bill of rights was lost. But the duke of Gloucester died in 1700, and in 1701 William's old plan was adopted, and the crown was entailed on the electress Sophia. All the descendants of James II. and Charles I. were passed over, and the preference given to a granddaughter of James I., for the sole reason that she was a Protestant. There were then living 57 persons who had claims to the crown superior to those of the electress, according to the received ideas of the right of succession. William was succeeded by the sister of his wife, Anne, second daughter of James II. In May, 1702, war was declared against France, that war which was illustrated by the deeds of Peterborough and Marlborough, and which lasted 11 years, when it was concluded by the treaty of Utrecht, in which the English are thought to have thrown away nearly all the fruits of their many victories. The war party had gone out of office in consequence of the hostility of the church, and their successors were supposed to aim at the restoration of the Stuarts. The union of England and Scotland was effected in 1707, the latter country being allowed to send 45 members to the house of commons, and 16 to the house of peers. Anne died Aug. 1, 1714, and the crown passed to the house of Hanover. The reign of George I. was by no means brilliant. The rebellion of 1715 in behalf of the Stuarts proved a failure, and the foreign movements for the same object were quite as useless. England allied herself with France, then ruled by the regent Orleans. The whigs returned to power, which they kept until the reign of George III. The South sea bubble caused great distress. Walpole's ascendancy began with its explosion, though he had been

in office long before that date. England was involved in war with Spain, and in 1718 won the naval victory of Cape Passaro. George I. died in 1727, and was succeeded by his only son George II., between whom and himself there had been bitter hatred. The new king, under the influence of his wife, Caroline of Anspach, continued Walpole in office, and that great minister was at the head of affairs until the beginning of 1742, baffling for years all the exertions of a most able and unscrupulous opposition. His principle of action was "to let well alone;" but he thought things were well which badly needed improvement. He allowed himself to be forced into a war with Spain, which departure from his system was soon followed by his fall, though he retained his influence over the royal mind to the day of his death. His successors were whigs in principle, and there was no chance for the Tories as a party under the first two monarchs of the Hanoverian line. War with France was added to that with Spain, growing out of the question of the Austrian succession. This war was one of the least glorious ever waged by England. In 1746 the contest between the reigning dynasty and the remains of the Stuart party was brought to an end at Culloden, where the duke of Cumberland defeated Charles Edward. The cruelties with which the Jacobites were punished reflect discredit on the English name. The treaty of Aix-la-Chapelle in 1748 restored peace to Europe for a few years. The whigs continued to rule, headed by Henry Pelham, and after his death in 1754 by his brother the duke of Newcastle. The renewal of the war with France in 1755 led to considerable ministerial changes, and in 1757 was formed the celebrated Pitt-Newcastle ministry, which carried on the contest with great vigor; so that when George II. died, Oct. 25, 1760, his fleets and armies were everywhere triumphant. The foundation of the East Indian empire of England was laid at Plassey, June 23, 1757. French America was conquered at Quebec, Sept. 13, 1759. The victories of Minden and Crefeld atoned for the days of Laffeldt and Fontenoy. Hawke's victory over Conflans was one of the noblest exploits of the British navy. The death of the king arrested the policy which had produced such results. The new king, George III. (the first English-born king of his house), grandson of George II., was by nature and education as despotic as the worst of the Stuarts, and resolved to attempt the restoration of the Stuart modes of government; and hence peace was his first object, that he might be at liberty for the work of internal change. He got rid of Pitt and made peace, but not until he had waged a brief war with Spain, that country joining the French in the last stage of the contest. The treaty was held to be very disgraceful to England, and it certainly was unwise to give up such islands as Martinique, Cuba, and the Philippines. Scarcely more wise was it

to retain Canada, whereby the English North American colonies were freed from any fear of French attacks, and any feelings of independence which they might have would be increased. Those colonies, however, would probably have been long in maturing the wish for separation from the parent country had they been well governed. With the exception of a few thoughtful men, the colonists were sincerely attached to the home government. The attempt of that government to tax them caused great indignation, and led to the American revolution. The English in the last years of the war had to fight the Americans, the French, the Spaniards, and the Dutch. The peace of 1783 left England in a low condition. She had been fortunate only in the East, where the ability and unscrupulousness of Warren Hastings increased her power. Shortly after the conclusion of the war George III. became popular, and saw the party which he hated excluded from office. The new phase of Toryism which manifested itself under the rule of the younger Pitt became the ascendant political principle of England for more than 40 years. When the French revolution broke out, the English ministry reluctantly engaged in the war that soon followed. A portion of the aristocratic whigs, headed by Burke, were more anxious for war than were Pitt and his immediate followers. The war lasted, with two brief intervals, down to the summer of 1815, ending in the complete triumph of England and her allies. The exertions made by England were vast. Her fleets, led by Nelson, Jervis, Howe, and Duncan, achieved splendid victories over the French and Spaniards, and in the last years of the war her armies were greatly distinguished under the lead of Wellington and others. In 1810 George III. lost his reason finally, and for more than nine years his eldest son, afterward George IV., was prince regent, succeeding to the throne in 1820. In 1812 England became involved in a war with the United States, growing out of the impressment and right of search questions. The contest was terminated by the treaty of Ghent, Dec. 24, 1814. The colonial and Indian dominions were much extended during the contest with France. On the other hand, England found herself burdened with a debt of \$4,000,000,000, and her expenditures had been on the most gigantic scale. After the restoration of peace in 1815, England entered upon a career of reform which has been more or less steadily followed ever since. This reform at first related to commercial and legal matters, but soon reached to others more peculiarly political. The passage of the Catholic emancipation act in 1829, under direction of a ministry headed by Wellington and Peel, showed that religious bigotry was no longer to receive the direct countenance of government; and the proceeding was but the fulfilment of the spirit of the treaty by which Ireland had been united to Great Britain in 1801, and, her own

parliament being abolished, allowed to send members to the imperial parliament. George IV., who had begun life as a liberal in politics, opposed this act, but was compelled to yield to the pressure brought to bear upon him by the Tory chiefs. He died the next year, 1830, and, having no legitimate children, was succeeded by his brother the duke of Clarence as William IV., whose short reign was a time of more political agitation than had been known since the revolution. Immediately after he became king happened the French revolution of July, 1830, which was followed by outbreaks in other parts of Europe, especially in Belgium and Poland. England felt these movements, and sympathized with the popular parties of the continent. In March, 1831, a bill for parliamentary reform was introduced into the house of commons by Lord John Russell, and after long debates in parliament and intense excitement in the country, caused by the opposition of the house of lords, a bill making extensive changes in the constitution of the house of commons finally passed in June, 1832, under the ministry of Earl Grey. The first reformed parliament, which met Jan. 29, 1833, contained an overwhelming majority of reformers. The dominant party, however, was too strong, and fell from its own weight. Irish troubles led to dissensions, and Lord Grey retired from office in 1834. He was succeeded by Lord Melbourne. Toward the close of the year Lord Althorp, chancellor of the exchequer, was obliged to vacate his office in consequence of his accession to the peerage as Earl Spencer. The king, who had been watching for an opportunity to get rid of the whigs, took this occasion to dismiss the ministry. The government was committed to Sir Robert Peel, who formed a conservative ministry, and made a bold effort to retain power, though it is not probable he would have advised the king to the step he had taken in dismissing the Melbourne ministry, for there were not 200 men in the commons who would have preferred the conservatives to the whigs. Parliament was dissolved, and in the elections which followed the conservatives gained largely; but the reformers had a majority, so that, though 35 reformers voted for the Peel candidate for speaker of the house of commons, he was beaten by a majority of 10. Peel continued in office until April 8, 1835, when he retired, having been repeatedly beaten on Irish church questions. His ministry had only lasted four months. Lord Melbourne returned to office, with many of his old colleagues. The king found himself forced to submit to the whigs; but it is said he was prepared to do something against them when he was seized with the illness which proved fatal to him, June 20, 1837. He was succeeded by his niece Victoria, the only child of Edward, duke of Kent, fourth son of George III. This event led to the separation of the crowns of England and Hanover, which had been worn by the same persons

since 1714, the Salic law prevailing in Hanover. The queen was very popular when she ascended the throne. She favored the whig ministry, which remained in office four years after her accession, though often rudely shaken, and once compelled to resign for a few days. There was a near approach to war with France in 1840, in consequence of disputes on the eastern question. In 1841 the long contest between the conservatives and the whigs came to a crisis, and after the latter had been more than once defeated, the house of commons declared its want of confidence in them by a vote of 312 to 311. Shortly afterward parliament was dissolved, and the subsequent elections ended in a conservative triumph. When parliament met, the ministers were beaten by 91 majority in the commons, and by 72 in the lords. They immediately resigned, and Peel formed a conservative ministry. The whigs, just before they had been expelled, had adopted the part of corn-law reformers, and the voice of the country was beginning to make itself heard on this question of food. In many respects Peel showed himself a reformer. He freed many articles from duties, and in other ways approximated to the position of a free trader. The more intense conservatives were dissatisfied, but the course of events was too much for them. The famine of 1845 compelled the ministry to discontinue their support of the protection policy, and the anti-corn-law league received much aid from the potato rot. The minister resigned, but was compelled to resume office, and to preside over the destruction of the corn laws, which were finally disposed of, June 26, 1846. The Peel ministry had from the first experienced much difficulty in the management of Irish affairs. The Melbourne ministry had pursued a liberal course toward Ireland, and received the support of Daniel O'Connell and his friends; but when the conservatives came into office, the Irish leader, between whom and the premier the utmost personal dislike existed, resumed the work of "agitation." He brought forward the repeal question, and meetings were held in various parts of Ireland, at which enormous numbers were present. Government interfered to prevent one of these meetings at Clontarf, Oct. 8, 1843. O'Connell, one of his sons, and eight other persons were arrested on charges of conspiracy, sedition, and unlawful assembling. They were tried and convicted, and O'Connell was sentenced to a heavy fine and a year's imprisonment, and required to find high recognizances to keep the peace for seven years. The case was carried before the house of lords, where the judgment of the lower court was reversed (Sept. 4, 1844). Though nominally beaten, government was really victorious, as from that time O'Connell's influence was essentially diminished. In 1846 the Peel ministry brought forward an act to protect life in Ireland, but it was defeated in the commons on the same day that the corn

laws were repealed, and the ministry came to an end, being succeeded by one at the head of which was Lord John Russell, and which ruled England through the European crisis of 1848-'9. A weak attempt to get up an insurrection in Ireland was put down, and the chiefs in it were transported. The Russell ministry went out of office in 1852, and for several months the Tories, led by Lord Derby and Mr. Disraeli, were at the head of affairs. This ministry was followed by one composed of coalesced whigs and Peelites, headed by Lord Aberdeen. In 1853 the troubles on the Turkish question began, and war was declared against Russia by France and England in March, 1854. Large fleets and armies were sent to the East, and fleets to the Baltic. The Crimea was invaded, the victory of the Alma won by the allies, and Sebastopol partially invested. The Russians brought up large forces, lost the battles of Balaklava and Inkerman, but were more successful in defending Sebastopol. Winter set in, and great sufferings were experienced by the besiegers. Alarming accounts of the sanitary condition of the army reached London, and although the allies had destroyed Bomarsund in the Aland islands, their expedition to the Baltic had failed. Much irritation existed in England, under the effect of which the Aberdeen ministry broke down, and was succeeded by one at the head of which was Lord Palmerston. The war was continued in the Crimea during the winter, but little progress was made in the siege. In the spring some brilliant successes were achieved; but on June 18 both French and English were repulsed in attempting to storm the Malakhoff and the Redan. Lord Raglan, the English commander, died soon after, and was succeeded by Gen. Simpson. On Sept. 8 the French stormed the Malakhoff, while the English failed before the Redan. The Russians immediately abandoned Sebastopol, and the war was now virtually at an end. Peace was restored by a congress of the great powers at Paris, in March, 1856; but England signed it reluctantly. It was as well for her that peace was restored, for not much more than a year after, and while engaged in hostilities with Persia and China, a conspiracy was formed in her great Bengal army of sepoy, which broke out in January, 1857. Delhi fell into the hands of the sepoy, and the nominal Mogul emperor found himself once more a sovereign in reality. The mutiny spread rapidly, and in a short time the whole Bengal army had become hostile to the English. The contest that followed led to the complete reestablishment of the English ascendancy. The military reputation of England was greatly raised by the successes of her armies in India, achieved under the lead of Sir Henry Havelock, Sir Colin Campbell, and others. In eight months after the breaking out of the mutiny there were nearly 70,000 effective English troops there, and new native corps had replaced the sepoy. By the end of 1858 this formidable revolt was totally

suppressed, and the few mutineers that remained were reduced to the condition of wandering brigands. The rebellion resulted in the transfer of the immediate government of India from the East India company to the crown, the old directory sitting for the last time Sept. 1, 1858. But the ministry under which measures so thorough had been initiated became unpopular, because it was supposed to be too subservient to the policy of France. A hostile vote in the house of commons in February, 1858, drove the Palmerston ministry from office, and a new conservative ministry was formed, with the earl of Derby as premier, and Mr. Disraeli as chancellor of the exchequer. This ministry soon resigned, and Lord Palmerston resumed office in June, 1859. England made some ineffectual efforts to prevent the war in that year between Austria and Italy. In 1860 an important commercial treaty was made with France, chiefly through the agency of Mr. Cobden, the leader of the English free traders. In 1861 great efforts were made to stimulate the cultivation of cotton in India, in view of the cutting off of the ordinary supply by the civil war in America. On May 13 the queen recognized the belligerency of the insurgents in America and the blockade of their ports, and proclaimed neutrality between the contending parties. In November Com. Wilkes, of the United States frigate *San Jacinto*, seized the confederate commissioners to England and France, from the British mail steamer *Trent*, then in the Bahama channel. This event created great excitement in England, but the commissioners were surrendered by the United States government. On Dec. 14 the prince consort Albert died. In the manufacturing counties there was great suffering from the cotton famine. In October, 1862, more than 150,000 operatives in Lancashire were entirely out of work, and 120,000 others were working only half time. This distress led some to urge the government to break the blockade of the cotton states; but it refused, and also declined the proposal of the emperor of the French for a joint mediation in American affairs. Government help was given to the distressed operatives, and private donations were made amounting to more than £1,000,000. Diplomatic correspondence with the United States in regard to the depredations of the privateer *Alabama* led to more settled feelings as to the American conflict, and on May 13, 1864, Mr. Cobden offered in parliament a petition for more practical efficiency in preventing violations of neutrality. On March 10, 1863, the prince of Wales was married to the princess Alexandra of Denmark. The throne of Greece was declined by Prince Alfred, and in 1864 the Ionian islands were finally ceded to Greece. In February of this year Denmark asked help of England against Prussia and Austria, and a conference in regard to Schleswig-Holstein met in London April 25; but nothing was done. The parliament elected in 1865 was strongly liberal. On

Oct. 18 Lord Palmerston died, having been premier, except for a very short period, since 1855, and Earl Russell took his place; but a reform bill introduced by the ministry being rejected by parliament as insufficient, they resigned. The conservative ministry which now came into office, headed successively by the earl of Derby and Mr. Disraeli, proposed a measure of reform more liberal than that of the liberals; and a bill was passed which effected the greatest change in the constituency of the house of commons since the reform bill of 1832. The act of 1867-'8, giving the suffrage to all householders, with certain limitations, increased the number of electors in England and Wales from 1,056,659 in 1866 to 2,012,631 in 1868. In 1868 an army organized at Bombay, under the command of Sir Robert Napier, and comprising 4,000 British and 8,000 sepoy troops, invaded and conquered Abyssinia, whose king Theodore had imprisoned and otherwise ill-treated a number of British subjects. Magdala, the chief fortress of the country, was captured by storm on April 13, when Theodore committed suicide. The British captives being released and the king dead, the English retired from the country without delay. In 1868 Mr. Gladstone introduced a bill for the disestablishment of the Irish church, and after a sharp struggle carried it through the house of commons against the government. Parliament was dissolved Nov. 11, and a most exciting election resulted in a liberal majority of 112. The ministry resigned before the meeting of parliament, and Mr. Gladstone was called to form a new ministry, of which John Bright became a member. The Irish church disestablishment finally became a law in July, 1869. The diplomatic correspondence with the United States in regard to the depredations of the privateer *Alabama* was continued, and a treaty was negotiated by Reverdy Johnson, minister to England, but rejected by the United States senate. The endowed schools for elementary instruction formed the subject of a report to parliament in 1869, which showed that the income of these schools, amounting to £592,000, was mostly wasted. A bill was then passed to give these schools real efficiency. In 1870 a general education act was passed, which aims to use all the old schools efficiently, organizes England and Wales into school districts, and provides for destitute regions by local taxation and by parliamentary grants. Education is not made free, but the school board of each district has power to remit school rates and to enforce attention to education. Under this act 300 school boards were at work in 1871, and included some of the most eminent and liberal men of the nation. Religious tests in the universities were abolished, as to all lay students, June 16, 1871. A bill for the abolition of the purchase and sale of commissions in the army was carried through the house of commons, but rejected by the lords, when the ministry took the unusual course of abolishing

the purchase system by royal warrant issued July 20, 1871. A commission was appointed the same year to settle the Alabama claims and the questions growing out of the fisheries on the coast of the eastern provinces of British North America. The commission met in Washington, where a treaty was signed May 8, which was quickly ratified by both governments. This treaty referred the Alabama claims to a board of arbitration to meet in Geneva, the northwestern boundary question to the emperor of Germany, and the other questions to a joint commission of three. The Geneva arbitration, after throwing out the claims of the United States for indirect damages, awarded an indemnification of \$15,500,000, which was finally paid at Washington in September, 1873. The emperor of Germany decided the boundary question according to the claim of the United States. In the great war between France and Germany in 1870-'71 England took no part.—*English Constitution.* The English constitution is not any formal instrument, adopted by a convention, but is the growth of all English history. Its commencement must be looked for in the time of the Roman occupation, which not only was a grand civilizing agency, but had its effect on those Germanic conquerors whom we call Anglo-Saxons. The Saxons, while destroying the male Britons, probably spared and married their women. This gave to England an important Celtic element. The invaders probably occupied the Roman towns. The conversion of the Anglo-Saxons to Christianity was an important step toward their civilization, and developed their characteristic ideas of order and law. They were gradually forming a Christian state, when the arrival of the Danes brought in a new element, favorable to the production of a free state. Both the aristocratic and the democratic element entered into the Saxon polity, the former attaining a decided predominance. The free classes were divided into thanes and ceorls, the former being nobles and gentry, and the latter the mass of the people. The possession of property determined the position and rights of the freemen. The thralls or slaves do not appear to have been very numerous. The local organizations regulated for the most part their own affairs. The country was divided into counties, the counties into hundreds, the hundreds into tithings. The county courts, and those of the hundreds, were popular tribunals. The witenagemote was the highest assembly, and was thoroughly aristocratic. The king presided in it, and it met by his summons. The earls, nobles by birth, as the thanes were from possession of property, attended it, and so did bishops and abbots. The thanes, too, had the right to sit in it. The local magistrates are supposed to have been occasionally present. The common people had no part in it, and were not represented. It made laws, and voted taxes when they were needed. It controlled the king, and could elect

him from among the members of the royal line. It was the highest court in all cases. The clerical influence in it was great, as it was throughout the country. The witenagemote had some of the elements of parliament, and its existence was not without effect in helping to form the polity that now exists. The Saxon aristocracy increased their power as time went on. The higher earls were fast becoming rulers of the state, when they and the people, Saxon and Danish, were all subdued by the Normans, another northern race, which had materially changed its character by a long residence in France. The conquest effected great changes in England. William I. introduced the feudal system into England, but with such modifications as prevented the sovereign from being enslaved by the nobility. The theory that the king of England is the supreme lord of all the land was established by the conqueror. This supremacy was directly and solemnly admitted by all the landed men of England in 1086, in an assembly at Salisbury. The lands which the king conferred on his followers were scattered over the country, so that it was impossible for his tenants *in capite* to increase into territorial potentates, as in France and elsewhere on the continent. He kept up the Saxon courts, but withdrew from the county courts cognizance of ecclesiastical matters. These popular courts he made more popular. This judicial system tended to keep down the baronial courts, which, like the barons themselves, never attained such consequence in England as they did elsewhere. Half the people were slaves, living in villeinage. Those attached to the soil, like the late Russian serfs, were villeins *regardant*, while the others, who could be sold away from the land, were villeins *en gros*. The number of the latter was not large. This was the result of the Norman rule, the English peasants being reduced to the condition of those of Normandy. In the reign of Henry II. the work of redemption began. Judicial interpretation was favorable to the enslaved classes. At the beginning of the 13th century there was a class of free laborers in England, small in numbers, but embracing the humbler people of the towns, and some of the peasants. The free peasant, no matter how complete his poverty, was compelled to be enrolled in the *decenna*, or subdivision of the hundred to which he belonged, and performed certain local political duties. He could act on inquests or juries. The landowners were tenants in chivalry, or holders by military tenure, and included the barons and other great men holding immediately of the crown, whose burdens were as great as their honors; tenants in free socage, who have been compared with the modern yeomanry, and whose condition was as good as that of any class of men in that time; and tenants in villeinage, men who had been emancipated, and who continued to reside on their old places, rendering their old services, or freemen who had taken

their places on the condition of discharging their obligations. There were not many of this last class of holders at the commencement of the 13th century. The conquered towns had passed into the hands of the Normans, but had obtained a certain degree of freedom by purchase, and also by charters, yet were liable to be specially taxed for the benefit of their lords. Such was the condition of England when John became king and carried the ordinary Norman tyranny to an extent that never was thought of by any of the preceding kings. A council of barons and prelates was held in 1213, at which Langton, archbishop of Canterbury, brought forward a charter of Henry I., which was well received. Another council was held in 1214-15, which extorted Magna Charta from the king. The charter itself is dated June 15, 1215, but the conference was not concluded until the 19th. The great charter, one of the landmarks of the history of freedom, laid the foundation of the English constitution in its broad and definite sense. It was renewed, with some omissions, in the reign of Henry III., who also granted the charter of the forest, modifying the forest laws. These charters were renewed five times in the same reign. The charter of Henry III. has been 30 times confirmed. The most remarkable of these confirmations was in the 25th year of Edward I. The government, as established in the 13th century, provided for a hereditary monarch with limited powers, taxation by parliament, punishment to be inflicted only after lawful trial, the cessation of arbitrary fines and imprisonment, trial by jury, and justice without price or delay. Parliament attained the distinctive character which it has had for more than 600 years in 1265, when borough representation was created. Knights of the shire were earlier summoned to the great council, and it was the intention of those who framed Magna Charta that cities and boroughs should be represented; but 50 years elapsed before their plan was carried out. Councils without burgesses continued to meet for some time after the establishment of parliament. That England obtained a symmetrical constitution in the 13th century, or that she has ever had anything of the kind, is not pretended by the most partial vindicators of her polity; but it is claimed, with strict justice, that then she became distinctly a free state, and that since that time she has been able to maintain liberty and order to an extent, and for a length of time, unknown to any other country. Monarchs and ministers frequently disregarded the restraints placed on them by the laws, but not even the most arbitrary of kings or the most reckless of ministers has ever gone beyond a certain line, save to be destroyed. The constitution continued to develop itself, and early in the 14th century we find the house of commons a great admitted power in the state. In the reign of Edward III. this body complained of the conduct of the

king's ministers, and in 1376 the first impeachment by the commons took place. In the affairs of war and peace the commons were then often consulted. It was provided that there should be frequent sessions of parliament, and 48 were held in the reign of Edward III. The minority of Richard II., and his weakness when he became of age, favored the growth of the power of the commons. That king sought to "pack" the house in 1398, a plain proof of its consequence. Parliament aided to depose Richard II., and to confer the crown on Henry IV., over the superior claim of the line of Clarence. Hallam, speaking of things as they were at the close of the 14th century, says: "Of the three capital points in contest while Edward III. reigned—1, that money could not be levied; 2, or laws enacted without the commons' consent; and 3, that the administration of government was subject to their inspection and control—the first was absolutely decided in their favor, the second was at least perfectly admitted in principle, and the last was confirmed by frequent exercise." In the 9th year of Henry IV. it was recognized that all money bills must originate in the lower house, and that the king should not take cognizance of the subject of that body's deliberations until it had decided upon it, and brought its decision before him regularly. Freedom of speech was reluctantly allowed by the sovereign, and Henry IV. did what he could to prevent it; and in the reign of Henry VI. a member of the commons was imprisoned because of a motion he had made; but as that motion related to the succession to the throne, and was made not long before the outbreak of the wars of the roses, perhaps the severity exercised toward him was owing to the jealousy which the Lancastrians felt toward the Yorkists. Members were then first privileged from arrest. Laws were passed to lessen the influence of the crown in elections, and to determine the qualifications of voters and representatives. At this time the desire to enter parliament was commonly felt, whereas in the preceding century it had been found necessary to enforce the election of representatives, while electors complained of the burden of paying members. The wars between the houses of York and Lancaster raised the consequence of the house of commons, as each party had to appeal to that body, and employ the power of parliament against its enemies. In 23 Henry VI. it was sought to provide that knights of the shire should be of gentle birth, but the law could not be enforced. There was a strong hereditary aristocracy; "but," says Macaulay, "it was of all hereditary aristocracies the least insolent and exclusive. It had none of the invidious character of a caste. It was constantly receiving members from the people, and constantly sending down members to mingle with the people. Any gentleman might become a peer. The younger son of a peer was but a gentleman.

Grandsons of peers yielded precedence to newly made knights. The dignity of knighthood was not beyond the reach of any man who could by diligence and thrift realize a good estate, or who could attract notice by his valor in a battle or a siege. It was regarded as no disparagement for the daughter of a duke, nay, of a royal duke, to espouse a distinguished commoner. Thus Sir John [Sir Robert] Howard married the daughter of Thomas Mowbray, duke of Norfolk. Sir Richard Pole married the countess of Salisbury, daughter of George, duke of Clarence. Good blood was indeed held in high respect, but between good blood and the privileges of peerage there was, most fortunately for our country, no necessary connection. Pedigrees as long, and escutcheons as old, were to be found out of the house of lords as in it. There were new men who bore the highest titles. There were untitled men well known to be descended from knights who had broken the Saxon ranks at Hastings, and scaled the walls of Jerusalem. . . . The yeoman was not inclined to murmur at dignities to which his own children might rise. The grandee was not inclined to insult a class into which his own children must descend." It would be wrong to infer from the real power and great consideration of parliament, that the king was not a sovereign of the first rank. He was very powerful, and did many things difficult to reconcile with the idea of the chief of a constitutionally governed country. Much depended on personal character, but even the weakest of kings possessed great prerogatives, and found not much difficulty in occasionally evading or violating the law, without causing public commotion. With three or four exceptions, all the English sovereigns that reigned between the days of Hastings and Bosworth were men of distinguished talents and much energy; facts that explain why liberal principles made no greater progress, and also show the earnestness of the English for free institutions, which were gained by no ordinary means from monarchs of such abilities, who were naturally averse to everything that tended to lessen their authority. The Tudors made great changes in various respects. Yet, says Froude, "in the house of commons, then as much as now, there was in theory unrestricted liberty of discussion, and free right for any member to originate whatever motion he pleased. But so long as confidence existed between the crown and the people, these rights were in great measure surrendered. The ministers prepared the business which was to be transacted; and the temper of the houses was usually so well understood that, except when there was a demand for money, it was rare that a measure was proposed the acceptance of which was doubtful, or the nature of which would provoke debate. So little jealousy, indeed, was in quiet times entertained of the power of the crown, and so little was a residence in Lon-

don to the taste of the burgesses and the country gentlemen, that not only were their expenses defrayed by a considerable salary, but it was found necessary to forbid them absenting themselves from their duties by a positive enactment." Throughout the entire existence of the Tudor dynasty there were instances of the sovereigns retreating from positions they had assumed, when they found they had done what was unpopular; and they retreated so well as always to save their dignity, and to prevent their prerogatives from being called in question. The resistance which the Tudors experienced when they endeavored to tax their subjects too highly can leave no doubt that the power of the people was as great as ever it had been, and that the new dynasty, whatever else it succeeded in changing, did not effect any change in the English character. They certainly bore hard upon the aristocracy, but this rather helped them with the people. The peerage was not then extensive. The first parliament of Henry VII. contained but 29 temporal peers, while in the parliament of 1451 there had been 53. The aristocracy had suffered immensely in the wars of the roses. The Tudors not only struck down many of its noblest members, but also elevated men from among the gentry and lawyers. The names of Russell and Seymour were not noble until the time of Henry VIII., or later. The Dudleys then rose to note. But whether new or old, the aristocracy were the true serviles of the Tudor times, not the people. Henry VIII., the most arbitrary of all the Tudors, says Bolingbroke, "by applying to his parliaments for the extraordinary powers which he exercised, and by taking these powers for such terms and under such restrictions as the parliament imposed, owned indeed sufficiently that they did not belong of right to the crown. He owned likewise in effect, more than any prince who went before him, how absolutely the disposition of the crown of England belongs to the people of England, by procuring so many different and opposite settlements of it to be made in parliament." The increased weight of the commons in the Tudor reigns is proved by the desire of the government to obtain victories at elections. New boroughs were then created for the express purpose of adding to the government's influence in the house of commons, and to this action are attributed the irregularities that have existed in the popular representation of England. Government interfered in elections, and bribed members of the house. Henry's daughter, Mary, dissolved two parliaments because they would not do what she desired; and the third was not always compliant. The abbey lands could not be restored to the church, nor the English crown settled on Philip II., because of the hostility of parliament to both schemes. The reformation had great political effects, the chief of which was the increase of the power of the crown. Henry VIII. was pope of Eng-



land for a time as well as king. His ecclesiastical supremacy was exactly what the words mean; but this was owing to circumstances and to his personal character, and his system died with him. When the Anglican church was finally established under Elizabeth, the sacerdotal character of the sovereign was disclaimed; but she held a vast power over the church, the ecclesiastical jurisdiction of the crown being complete. "The act of supremacy," says Hallam, "empowered the queen to execute it by commissioners appointed under the great seal, in such manner and for such time as she should direct; whose power should extend to visit, correct, and amend all heresies, schisms, abuses, and offences whatever, which fall under the cognizance and are subject to the correction of spiritual authority." After several temporary commissions had sat under this act, the high commission court came into existence in 1583. A more arbitrary tribunal never existed. Burleigh opposed the procedure under it, but, influential as he was, his opposition availed nothing. The house of commons was hostile to the high ecclesiastical party, and its opposition was not that of a servile body. "The regiment of England," said Aylmer, afterward bishop of London, "is not a mere monarchy, as some for lack of consideration think, nor a mere oligarchy, nor democracy, but a rule mixed of all these, wherein each one of these has or should have like authority. The image whereof, and not the image but the thing indeed, is to be seen in the parliament house, wherein you shall find these three estates: the king or queen which representeth the monarchy, the noblemen which be the aristocracy, and the burgesses or knights, the democracy. If the parliament use their privileges, the king can ordain nothing without them; if he do, it is his fault in usurping it, and their fault in permitting it. Wherefore, in my judgment, those that in King Henry VIII.'s days would not grant him that his proclamation should have the force of a statute were good fathers of the country, and worthy commendation in defending their liberty." This was written in 1559, the first year of Elizabeth and the 74th of the Tudor rule; and it is not possible that it could have been written had England been despotically governed by the Tudors. To the same purport are the observations of a far greater writer of the Elizabethan time, made in its last days. "I cannot choose," says Hooker, "but commend highly their wisdom, by whom the foundation of the commonwealth hath been laid; wherein, though no manner of person or cause be unsubject unto the king's power, yet so is the power of the king over all and in all limited, that unto all his proceedings the law itself is a rule." The contest that commenced when the house of Stuart succeeded to that of Tudor, the opening scene of the English revolution, was the work of the government, and the revolutionary party consisted of that govern-

ment and its adherents. The "country party," as the opposition came to be called, was in the strictest sense of the word a conservative party; and if, in the course of the long struggle of 86 years, it had occasional resort to acts apparently revolutionary, it was because the security of liberty was found compatible only with the removal of that government which would have overthrown the last survivor of those constitutions of which there had formerly been so many in Europe. The divine right theory, which was so zealously preached in the reign of James I., was meant to prepare the way for the subjugation of the people, and for the concentration of all power in the hands of the central authority. Charles I. was bent upon not being a Venetian doge, and some able modern writers have written as if they believed there was a close resemblance between a king of England, who had only to rule according to law and his oath, and the shadowy phantom that did not even play at ruling on the Adriatic. A great power has always been wielded even by the most constitutionally inclined English monarchs, and popular feeling has often been with such kings against the aristocracy, but always on the condition that the king ruled according to law, a fact that it was impossible for Charles I. to comprehend. The contest was for power over the purse; which secured, power over the sword followed as of course. The third parliament of Charles I. passed the petition of right, an instrument superior to Magna Charta itself, and to which the king gave his consent. In it are pointed out the breaches that had been made in the law, the constitutional rights of Englishmen are declared, and the king is prayed to rule legally. Even if there had been a despotism in England previous to 1628, it ought then to have come to an end, after king and parliament had solemnly agreed upon the terms on which the government should thereafter be carried on. Yet the king violated the petition of right in the most flagrant manner, and did not call a parliament for 11 years, which was unprecedented. During that time England was as arbitrarily governed as France by Richelieu, without any of that glory which Richelieu's foreign policy was gaining for France. The machinery of despotism was found to be perfect within certain and by no means narrow limits. The jurisdiction of the court of star chamber was very great, and the proceedings in that court were more numerous and violent than they had been under the Tudors. The objects aimed at appear to have been to accustom the people to the administration of justice by a court directly dependent upon the king, and uncontrolled by law or precedent, and to increase the royal revenue by penalties and forfeitures. The cruel, atrocious punishments inflicted by the star chamber are as well known as the sentences passed at the bloody assizes. The council of the north, which had been created by Henry VIII., but which for 96 years had compara-

tively limited powers and jurisdiction, was converted into a star chamber for all that part of England which lies between the Humber and the Tweed. Wentworth, the president of this council, contrived to make it even worse than it would have been under the presidency of any other man. Proclamations were frequently resorted to, and were made to have the force of law. They intermeddled with almost every department of life, to the great grievance of the subject. Yet nothing can be clearer than their unconstitutionality; and until the Stuart age they were but little known. James I. made them common, and his evil example was outdone by his successor. The case of ship money has attracted extraordinary attention, which is in part due to the character of Hampden; but it was one then calculated to excite all men's attention in itself, for it showed that no dependence could be placed on the common-law courts, and that those tribunals were nearly as bad as the irregular tribunals which Charles, and Wentworth, and Laud employed to plunder the property, to restrict the liberty, and to mutilate the persons of Englishmen. "Ship money," says Hallam, "was held lawful by Finch and several other judges, not on the authority of precedents, which must in their nature have some bounds, but on principles subversive of any property or privilege in the subject. These paramount rights of monarchy, to which they appealed to-day in justification of ship money, might to-morrow serve to supersede other laws, and maintain new exertions of despotic power. It was manifest by the whole strain of the court lawyers, that no limitations on the king's authority could exist but by the king's sufferance. This alarming tenet, long bruited among the churchmen and courtiers, now resounded in the halls of justice." A reconciliation was sought with Rome, and Catholic troops were to be employed to control the Scotch and English. Even had there been no religious grievances to complain of, the political grievances were so vast and so various, that they would have justified a resort to arms on the part of all who cared for constitutional government. But there were religious grievances in abundance, though so "thorough" had been the repression exerted by Laud, that he could report to his master a most happy absence of nonconformity in 1639, "on the very eve of a revolution, in which primate and church, and monarch and monarchy, were to perish together." The religious element had much to do with bringing about the contest that commenced in 1640. The fourth parliament of Charles I. met in April, and was soon dissolved; and six months later met the most memorable parliament that ever assembled. That parliament fought the battle of the constitution, and fought it successfully. The entire machinery of despotism was broken down, most of it never to be rebuilt. The star chamber, the council of the north, and the high commission

court disappeared from England, the first two for ever, and the last to be only temporarily revived by James II. This would have ended the quarrel could the king have been trusted. But to trust him was quite out of the question, and parliament, to preserve the freedom of the country, resorted to measures which were not according to the letter of the constitution, though in keeping with its spirit. The king was forced to agree that parliament should not be dissolved without its own consent, which was an invasion of his prerogative; and later it was resolved that no minister should be appointed or peer created without the consent of parliament, and that the king should be made to resign the supreme military authority, which he justly held to be the very flower of the crown, and which was unquestionably one of its most ancient attributes. This conduct, indefensible on mere technical grounds, was proper in reference to the object in view, which was to put an end to illegal government by the king, who had repeatedly proved himself incapable of keeping his word. War soon broke out, and the king was supported by a large number of constitutionalists, men who were prepared to maintain the government as it was after the early reforms of the long parliament had been accomplished, but who dreaded innovation. The war led to the suspension of the constitution, and the protectorate of Cromwell was mainly a government by the sword, in spite of the fact that the protector sincerely wished to rule as a constitutional monarch. In 1660 the house of Stuart was restored, without anything having been done to secure legal rule. The old polity came once more into full force. The government was what it had been, nominally, before Charles I. and parliament appealed to the sword, though the star chamber and high commission courts, and other institutions of tyranny, no longer had place in England. Tenures by knight service were abolished, and most of the soil of England was held under that tenure. The parliament of 1661, which lasted down to 1679, was fanatically attached to royalist principles, and to its fanaticism must the bad government of Charles II. in no small degree be attributed. His reign is one of the worst in English history, but his first parliament was as bad as the king. Yet in that reign much was done that had permanent effect on the constitution. The dispensing power was condemned by parliament, and its illegality admitted by the king himself. The test act was passed. The *habeas corpus* act, which supplied a proper system of procedure to preserve the liberty of the subject, was adopted, and received the support of all Englishmen who were not anxious to see despotism established. Parliament made war or peace at its pleasure. It was now obvious not only that parliament had become the chief power in the state, but that the house of commons was virtually parliament. To counteract this, the king adopted

a plan recommended by Sir William Temple. He created a new council, or extended the privy council to 30 members, 15 of whom were to be the chief ministers, while the others were to be nobles or gentlemen, without office, but of wealth and consideration. It was expected that this council would satisfy all parties, but it satisfied nobody, and failed from the commencement of its existence. The old form was soon restored. A tory reaction made the calling of parliament together unnecessary in the last years of Charles II. His successor, James II., not content with an amount of power such as no other sovereign of his line had possessed, entered upon a course of action that plainly showed he had in view the total overthrow of the constitution both in church and state; and as his staunchest supporters had been churchmen, all parties in England were soon arrayed against him, except a few Catholics and a small portion of the dissenters. He had called a parliament immediately after his accession, and though it was the most servile body that had met for 80 years, and the king had said there were only 40 members of the house of commons whom he would not have named himself, he soon quarrelled with it. The ends which he had most at heart were, the repeal of the *habeas corpus* act, the establishment of a standing army, and the repeal of all laws that were directed against the Catholics. It so happened that these three things were precisely those which his own friends, the tories, were least inclined to grant. They were as much attached to the *habeas corpus* act as were the whigs; they associated the idea of a standing army with the military rule of Cromwell; and they saw ruin to the church of England in relief to the Catholics, and the one thing which they loved better than either monarch or monarchy was that church. For three years James carried on a warfare against the constitution, reviving the high commission court by his own act, and in defiance of acts of parliament, and in various other ways showing his utter contempt of all restraint. The events of 1688-'9 removed him from the throne, and placed the constitution on a firm basis, on which it has since rested without serious disturbance. The government of parliament was then fairly acknowledged, and has never since been called in question. In the reign of William and Mary, and of William III., many things were done to settle the principles of the constitution. The declaration of rights adopted by the convention parliament was confirmed by the regular parliament, soon after; and the act of settlement passed in 1700 contains eight additional articles, further limiting the power of the crown, and protecting popular freedom. The most important of these articles is the seventh, by which judges were to hold their seats during good behavior, and their salaries were to be ascertained and established. The first mutiny bill was passed in 1689, and has been renewed annually ever

since, giving to parliament control of the sword. A triennial bill was passed in 1694, but septennial parliaments were established in 1717. As the law originally stood, the king could keep the parliament chosen immediately after his accession to the throne during the whole of his reign. The triennial act repealed this prerogative, and the septennial act confirmed that repeal, while it extended the time for which parliament might endure. No parliament, however, since that time has existed for seven years. The laws relating to treason, to libel, and to toleration, passed in the year immediately following the revolution, and which became part of the constitution, were generally of a liberal character. After the accession of the house of Hanover, an attempt was made by a portion of the whigs to close the house of peers. George I. gave his consent to the introduction of a bill by which, after a few more creations, no additions were to be made to the peerage. For the 16 elective peers of Scotland, 25 hereditary peers were to be substituted. This measure succeeded in the house of peers, but the house of commons, under the lead of Walpole, threw it out. The government was strictly parliamentary down to the beginning of the reign of George III. That monarch attempted to rule parliament, and did not desist until he found that his best chance to accomplish his purpose would be through a union with that body. The demand for parliamentary reform commenced in the time of the American revolution, and was caused by the conviction that began to prevail among men of all classes that the existing abuses were owing to the vices of the electoral system. The French revolution had the effect of delaying changes in England that were much demanded, as numerous members of the house of commons were returned by peers, or by rich individual commoners. The reform bill of 1832, and that of 1867-'8, though greatly enlarging the constituency of the house of commons in some respects, did not lessen the power of that body, which is more influential now than ever before. The exclamation of Mr. Roebuck in 1858, "The crown! it is the house of commons!" expresses the precise character of the government of the British empire. (See PARLIAMENT.) The sovereign, in theory, is almost as powerful as in early times, but in practice his power can hardly be said to exist. He can make war or peace, but the control of the purse and the sword by parliament neutralizes that prerogative. The money to pay the salaries of the officers he appoints must be voted by parliament. He cannot alter the standard of the money which it is his privilege to coin. The appointments he makes are virtually made by parliament, the ministers being only a committee of members of that body, selected from it by its consent, and responsible to it. He is held to be incapable of doing wrong, and the ministers are responsible for all that is done in his name, which, whatever its

justice in former times, is proper now, the king being capable of doing nothing, while his "advisers" do everything. He is head of the church, but he cannot alter the state religion, and should he become a Roman Catholic he would forfeit his crown. The succession to the crown is what is known as *semi-Salic*; that is, females can inherit and transmit the sovereignty. Females of a nearer consanguinity to the sovereign take precedence over males of a more remote degree; but in the same degree of consanguinity males, irrespective of order of birth, take precedence over females. The privy council is appointed by the king, and is bound to advise him to the best judgment of the members. With the advice of this body the king can publish proclamations, provided they are of a legal character. The council can inquire into all offences against government, and commit offenders for trial. The judicial committee of the council is a court of appeal in cases of lunacy and idiocy, and in admiralty and plantation causes, in questions between colonies, and all kindred questions. It has an appellate jurisdiction over all parts of the empire, except Great Britain and Ireland, in the last resort. The executive government is in the hands of the ministry, which consists of the leading men of the dominant party. This has not always been the custom, for though there have always been ministers, a ministry was not formed till after the revolution, of which event it was one of the consequences. The cabinet, though now formed from the ministry, and often confounded with it, is not identical with it, and is indeed much older than the ministry. It originated in the custom, which was inevitable, of intrusting power to some few of the king's ministers. In the reign of Charles I. this knot of ministers, or "juncto," as they were called, were in the habit of holding meetings in the cabinet of the queen consort, Henrietta Maria, whence the name came to have its present meaning. The word *cabal* had the same meaning for a time, but the unpopularity of the cabal ministry, in the reign of Charles II., caused it to become so odious that it has never since been employed in a respectful sense. The cabinet, or rather the cabinet council, has never been recognized by the law, it has no legal existence now, the names of the persons who compose it are never officially published, and no record of its doings is kept. The difference between the cabinet and the ministry may, perhaps, be best stated by mentioning the composition of the existing English government. The ministry now consists of 31 persons, but the cabinet has only 16 members, viz.: the first lord of the treasury, chancellor of the exchequer, lord chancellor, president of the council, lord privy seal, secretaries of state for the home department, for foreign affairs, for the colonies, for war, and for India, first lord of the admiralty, first commissioner of works, chief secretary for Ireland, president of the local government board, vice president of the edu-

cation committee of the privy council, and the chancellor of the duchy of Lancaster. Among the ministers who are not of the cabinet are the commander of the forces and the postmaster general. The post of prime minister, or premier, has generally been held by the first lord of the treasury since the accession of the house of Hanover. It was most commonly held by the lord treasurer in earlier times, but there has been no such officer since 1714, the office being in commission, and it was Sir Robert Walpole who first attached the place of prime minister to that of first lord commissioner of the treasury. Previous to that time a secretary of state had higher official rank than the head of the treasury; and after Walpole's fall, Lord Carteret (Earl Granville) was the principal man of the ministry to which he belonged, and was a secretary of state. It has sometimes happened that force of character has enabled a secretary of state to be premier in fact if not in name, as in the cases of the elder Pitt, Lord Castlereagh, and Mr. Canning; but the rule is, that the first lord of the treasury is premier. The two offices of first lord of the treasury and chancellor of the exchequer have sometimes been held by the same person, as they were for a time by Mr. Gladstone in 1873. The king can call a privy councillor to the cabinet, though he hold no office; and eminent men have sat in that body merely as cabinet councillors.—The principal authorities for the general history of England are: the works of Turner, Palgrave, Kemble, and Lappenberg, on the Saxon times; Hallam's "Europe during the Middle Ages," and "Constitutional History of England;" Thierry's *Conquête de l'Angleterre par les Normands*; Freeman's "History of the Norman Conquest;" the works of Stephen, Creasy, May, and Raikes on the English constitution; the histories of England by Hume, Lingard, Knight, Mackintosh, Macaulay, and Froude, the last three being devoted to special portions of that history; and Pauli's continuation of Lappenberg.

**ENGLAND, Church of,** the church established by law within the realm of England, and until 1871 of Ireland. Its origin is readily traced in English history, Christianity having gained a foothold in England at a very early date, and assumed from the first a more or less perfect ecclesiastical organization. It is held by some that the gospel was preached in Britain in the 1st century. Tertullian about the year 200 speaks of places in Britain which, though inaccessible to the Romans, were subject to Christ. There is no doubt that the Britons were generally converted to the Christian faith before the Saxon invasion in 449. Three British bishops were present in 314 at the council of Arles, one from York, one from London, and one from Caerleon in Wales; showing that the church was regularly organized at that date. There were also British bishops in the councils of Sardica in 347, and of Rimini in 359; and about the close

of the 3d century St. Alban suffered martyrdom during Diocletian's persecution. In the middle of the 5th century the Saxons arrived, and in the course of the century following they had nearly exterminated Christianity except in Wales and Cornwall. In 596 the monk Augustin came as a missionary from Gregory I., bishop of Rome, and found Bertha, the queen of Ethelbert, a Christian; and with the help of the remnant of the church still in the west and in Wales, Christianity was soon reestablished. Augustin found seven bishops in Wales, with whom he held conferences in the effort to bring them into conformity to the church of Rome. The British Christians, however, like the Greeks, celebrated Easter on the third day after the 14th of the Jewish month Nisan, whatever day of the week that might be (see *EASTER*), and practised baptism by trine effusion, and could not be induced to conform their practice to that of the Latin church at that date. These facts are emphasized by those who hold that the Anglican church was always really independent of Rome, and at the reformation simply resumed her position as a free national church. In the course of a few generations, however, the Roman supremacy prevailed, and secured a general conformity of doctrine and usage. Monastic houses were established, exempt from local ecclesiastical jurisdiction, and subject only and directly to the pope. The Norman conquest also contributed largely to the influence of Rome. The contests between the conquering Normans and the conquered Saxons continued until they were settled by the accession of Henry I. and Matilda of Scotland; and after that the struggle between the king and his barons contributed to the same result, as both parties appealed to the powerful help of the bishop of Rome. The papal supremacy was most complete when King John resigned his crown into the hands of the pope, and received it back to be held by him on condition of an annual payment. From this period there was no absolute rejection of the papal authority, although there were occasional disturbances and protests, growing stronger and more influential until the opinions of Wycliffe had leavened the Anglican church. Henry VIII. had married Catharine of Aragon, the widow of his brother Arthur, but began to question the legality of his marriage. The nation was also anxious about the succession to the throne, and Henry wished to prepare the way for a union with Anne Boleyn, and requested the pope to declare his first marriage null *ab initio*, or to grant a divorce. The pope not complying, he referred the matter, by the advice of Thomas Cranmer, to his own clergy, among whom, as well as from some foreign universities, he received opinions favorable to his wishes. Cranmer, who had been made archbishop of Canterbury, now proclaimed the king's marriage with Catharine void, and confirmed his union with Anne Boleyn, whom he had privately wedded

a few months before. The pope threatened the king with his heaviest censures, but Henry resolved to throw off the papal supremacy, and measures were at once taken to subject the clergy exclusively to the crown. A blow had already been struck at the old ecclesiastical system by the indictment of the English clergy in 1531 for supporting Wolsey in his powers as legate before receiving the royal sanction; and in the convocation held immediately after, in which a sum of money was voted to the crown by way of buying immunity from the consequences of conviction on this charge, the king was acknowledged to be "the one protector of the English church, its only and supreme lord, and, as far as might be by the law of Christ, its supreme head." By the same assemblage his marriage with Catharine was declared null, and in 1532 the parliament passed an act against paying to the pope the annates, or year's revenue of all bishoprics that fell vacant, which had formerly been paid to Rome as a tax on bulls issued to new prelates. At the same time it was ordained that no regard should be paid to censures which the pope might pass on account of this law, and that mass should be said and the sacraments administered as usual. In 1534 still more important measures were enacted. All payments made to the apostolic chamber, all bulls and dispensations were abolished; monasteries were subjected to royal government and visitation, and exempted from all other; the right to summon convocations, approve or reject canons, and hear appeals from the bishops, was vested in the king alone; and sentence of deposition was passed upon Campeggio and Ghinucci, bishops of Salisbury and Worcester. Though now honored with the title of supreme head of the church on earth, Henry contemplated no change in the doctrines of the church as then held, and no setting up of a rival community. Indeed, it was not until 30 years or more after these steps that the Roman Catholics and the reformers were looked upon as separate bodies, or had separate ministrations and separate places of worship. Throughout Henry's reign much less was done toward a change in creed or ritual than during the short reign of his son, Edward VI. The fundamental principle avowed from the first to the last, however, was that, besides retaining the ministry and the creeds of the primitive church, they must in all points of doctrine and discipline also accept its authority. In this view the offices of devotion were expurgated of what were deemed errors and innovations, and translated into English (having been previously used in Latin), and brought together as a "Book of Common Prayer and Administration of the Sacraments," in 1548-'9. A "Book of Homilies" was prepared in 1540 and 1547, to be read in all the churches for the instruction of the people; the Bible also was translated, and not only read in public worship by the clergy, but copies were placed at the public expense in

the churches, where they were accessible at all times. The details of this great change, and the growth and change of opinion among the people, appear in the lives of Sir Thomas More, Wolsey, Fisher, Thomas Cromwell, Cranmer, Latimer, and Ridley, and in the "Bishop's Book, or the Godly and Pious Institutions of a Christian Man" (republished in 1543 and called the "King's Book," because issued by royal authority), and the "Book of Articles, devised by the King's Highness Majestie to stablyshe Christen Unities." The "Forty-two Articles" (afterward the "Thirty-nine Articles"), drawn up under Edward, summarize the views of the church of England in regard to her position, and her refusal to submit to the corruptions and assumptions of Rome. On the death of Edward VI. Mary, daughter of Henry VIII. and Catharine of Aragon, Henry's first wife, ascended the throne. She was a devout adherent of the papal authority, and set herself to secure its recognition in England. To prepare the way for the realization of her object, an important change was made in the position of the bishops. Some were declared to be no bishops, because they were married men; some were deprived of their sees because they had been appointed to them only during the good pleasure of the king. Five were condemned and burned at the stake, among the 280 martyrs who perished during this reign. Thus under Mary's rule the state again became Roman Catholic; but in about five years she died, and was succeeded by Elizabeth, the daughter of Henry and Anne Boleyn, who brought back the reformed faith and usages. The "Act of Uniformity," passed in the first year of her reign, restored the "Book of Common Prayer." All the bishops except one, Kitchin of Llandaff, refused to take the oath of uniformity, and were ejected from their sees to the number of 14; the 11 remaining sees were vacant by death. Their places were filled, though with some difficulty; but of the 9,400 beneficed clergy fewer than 200 gave up their livings. In 1563 the XXXIX articles were finally reviewed and subscribed. There was a continual struggle between the Calvinistic Puritans and the more conservative churchmen. Toward the close of the reign of Elizabeth her favorite archbishop, Whitgift, drew up, in concert with the bishop of London and other theologians, the instrument known as the "Lambeth Articles," which is strongly Calvinistic. On the other hand, the Hampton Court conference, January, 1604, although formally an attempt to satisfy the Puritans, in fact decided every important point against them. In the reign of Charles I. the ecclesiastical administration was principally directed by Archbishop Laud, whose opposition to the Puritans was manifested in the persecutions of the high commission. These oppressions, added to the civil oppressions of the star chamber, resulted in the overthrow and death of King Charles, and from 1653 to 1660 the church of England was practically suspended. With the restoration

of the monarchy in 1660 came the restoration of the church. The popular reaction against Puritanism was complete. The Savoy conference in 1661 failed to effect any reconciliation, and the act of uniformity in 1662 resulted in the ejection of 2,000 nonconformist or Presbyterian ministers from their livings. In 1687 James II., who was a Roman Catholic, issued the "Declaration of Indulgence," which professed to permit liberty of conscience to all his subjects, but was really in the interests of the Roman Catholics only. Of the 25 bishops, 18 refused to publish the declaration in their dioceses. Seven of them drew up a remonstrance to the king, and were summoned before the privy council and thrown into the tower. Their trial, which resulted in their acquittal, was one of the leading causes of the revolution of 1688, although on the accession of William of Orange eight of the bishops and about 400 of the clergy refused to swear allegiance to him, and became known as the "nonjurors." In the first year of the reign of William and Mary the "Toleration Act" was passed, and dissent ceased to be illegal. The violent discussions of the doctrines put forth by Bishop Hoadley in the lower house of convocation, in 1717, led to the dissolution of the convocation and the restriction of its jurisdiction. The period of strife was followed by a period of dulness and indifference, which gave occasion to the Wesleyan or Methodist movement, and the rise of the evangelical schools of Newton, Toplady, and Simeon; and this in turn led in 1833 to the publication of the "Oxford Tracts," and that effort to revive the principles and practices of the mediæval church which has been characterized as "Puseyism." These controversies have resulted within the church in the formation of three well recognized schools, known under the designations of high church, low church, and broad church. The high churchmen regard the apostolical succession, in the three orders of the ministry, as of divine authority and obligation, and the sacraments as channels of grace. With the extreme low churchmen episcopacy is rather an expedient than a necessary form of church government, while they sympathize with the general doctrinal views of the evangelicals of continental Europe. The broad churchmen are unwilling to be called a party, but stand in some degree antagonistic to both the high and low church parties, and embrace within their ranks some of the most gifted and intellectual men of the church, including a number of the extreme rationalists, and are more tolerant of difference of dogmatic belief. More recently the church has given much of its strength to works of benevolence and to the evangelization of the masses; while there has been great variety both of doctrinal opinion and of liturgical observance. Under Charles I. an unsuccessful effort was made to extend the church of England over Scotland. The act of union, which went into effect Jan. 1, 1801, united the Epis-

copal churches of England and Ireland, the church of England and Ireland being the state church, established by law in Ireland, although its adherents formed but a small minority of the Irish population. But by act of parliament which took effect Jan. 1, 1871, the Irish church was disestablished. (See IRELAND, CHURCH OF.)—The church of England is divided into two provinces, Canterbury and York, with an archbishop in each, and under these 25 bishops. The bishop of Sodor and Man does not sit in parliament. The other English bishops constitute the spiritual peerage of England, and are appointed by the crown. Next to the archbishops rank the bishops of London, Durham, and Winchester, and the others take rank according to the date of their consecration. In 1872 there were 12,837 benefices in England and Wales. The church rates amount to more than £500,000, but are no part of the ministers' endowment, being devoted exclusively to the repairs and incidental expenses of the churches. New parishes, which are frequently formed out of old and over-populous ones, are for the most part very slenderly endowed. The old benefices are rectories, where the incumbent receives the great or corn tithes, or vicarages, where he receives the small tithes only. The great tithes had been bestowed formerly upon the neighboring monasteries, and at their dissolution were given to laymen and to endowed colleges. The total annual revenue of the church property in 1830 was £3,192,885, of which less than £1,000,000 belonged to the Irish branch. The average joint support of incumbents and curates is now about £300 per annum. An ecclesiastical commission was appointed in 1836, and some approach made toward converting the income of the church into a common fund, with a distribution to be made according to the wants and necessities of each office. The incomes paid to the bishops range from £15,000 to the archbishop of Canterbury to £2,000 paid to the bishop of Sodor and Man; and the aggregate of the episcopal incomes being (in 1872) £154,200. There are 30 deans with incomes ranging from £3,000 (Durham) to £700 (Bangor). As assistants of bishops there were (in 1872) 72 archdeacons, and under them were 565 rural deans. The clergy of every class were estimated at 18,000. The number of parishes is about 12,000; and the aggregate number of sittings in all places of worship in 1872 was 5,701,700. The official census of England gives no information regarding the numerical strength of the population connected with the church of England, and the estimates differ considerably. In Martin's "Statesman's Manual" for 1873 it is estimated at 12,700,000, or only little more than one half; in Ravenstein's "Denominational Statistics of England and Wales" (London, 1870), at 77.8 per cent. of the total population, which according to the census of 1871 would be 17,781,000. Nearly all writers on this subject agree that the church of England has been during the

last 20 years steadily losing ground. While the number of dioceses in England has long been stationary, that of the colonial and missionary bishops has of late rapidly increased. The first colonial see established was that of Nova Scotia, in 1787; next came Quebec, in 1793. The first East Indian see was that of Calcutta, founded in 1813; the first West Indian, that of Jamaica, 1827; the first Australian see (Sydney) was established in 1836; the first of South Africa in 1850. In 1873 there were 54 colonial and missionary dioceses in connection with the church of England. Of these, 5, Bombay, Calcutta, Colombo, Labuan, and Madras, were in the East Indies; 5, Antigua, Barbadoes, Jamaica, Nassau, and Trinidad, in the West Indies; 2, Guiana and Falkland islands, in South America; 9, Cape Town, Graham's Town, St. Helena, Natal, Mauritius, Central Africa, Orange River State, Eastern Africa, and Madagascar, in south and east Africa; 2, Sierra Leone and Niger, in west Africa; 10, Adelaide, Bathurst, Brisbane, Goulburn, Grafton, and Armidale, Melbourne, Newcastle, Perth, Sydney, and Tasmania, in Australia; 10, British Columbia, Fredericton, Huron, Montreal, Newfoundland, Nova Scotia, Ontario, Quebec, Rupert's Land, and Toronto, in British North America; 6, Christ Church, Nelson, Auckland, Wellington, Whaiagua, and Dunedin, in New Zealand; the remainder were the dioceses of Melanesia in the Pacific, of Honolulu in the Hawaiian islands, of Victoria in Hong Kong, of Gibraltar, and of Jerusalem. Besides the church of Ireland, also the Episcopal church of Scotland and the Protestant Episcopal church of the United States agree in doctrine with the church of England. (See EPISCOPAL CHURCH.)

**ENGLAND, Language and Literature of.** The English is preëminently a composite language, made up mainly from the Celtic, Latin, Anglo-Saxon, Danish, and Norman French, with the addition of words from the Greek and many other languages, ancient and modern. For the investigation of this subject there are two modes. One is linguistic, and is more strictly philological. The affinities and diversities of the various words in the language furnish the internal evidence of the several sources from which the vocabulary and the constructions were derived. The other mode, which is ethnological, and which furnishes the external evidence from the history and migration of nations, often conducts to the same conclusions with the linguistic method. When, for instance, we hear of a stream called *Wans-beck-water*, and know that each of the three words of which the name is made up signifies "water," the first in the Celtic, the second in the German, and the third in the English, we recognize three changes of inhabitants, to whom the former name successively lost its significance. This is internal evidence. We also know from history that the Celts, the Saxons, and the English have successively occu-

pied the territory where that stream is found. This is external evidence. Both kinds of evidence in this case conduct us toward the conclusion that the Celts and Saxons contributed materials to the formation of the language.—*The Celtic Element.* In the English vocabulary are found basket, from the Celtic *basged*; mattock, from *matog*; pail, from *paөл*; and other words of like derivation. Moreover, a large part of the names of the mountains, lakes, and rivers in the British isles are significant only in some Celtic dialect. The Celts emigrated westward from central Asia in the early ages. They were probably pressed onward by other tribes, until they reached the seaboard and passed over the English channel into Great Britain. Their descendants are still found in Wales and in Cornwall, as well as in Ireland, in the highlands of Scotland, in the isle of Man, and in Brittany. The English language has few Celtic words, and no Celtic constructions.—*The Latin Element.* In the English vocabulary are found street, from the Latin *stratum*; master, from *magister*; state, from *status*; April, from *Aprilis*; and many other words of like derivation. The Romans under Julius Caesar invaded England, 55 B. C., and afterward under Agricola completed its conquest. The forms *caster*, *cester*, and *chester*, which appear so frequently in the names of places, as Lancaster, Worcester, and Winchester, are merely the Latin *castra*, camp, and show that the Romans held military possession of the whole country, establishing their fortified camps in the most favorable positions, around which in time grew up towns and cities. Roman law and magistracies were everywhere established, and the Christian religion was introduced by those who spoke the Latin language. But for the most part the Latin words in the language were not introduced during the 400 years that the Romans had possession of Britain, but afterward, while the Anglo-Saxons bore sway, or later still. A large number of Latin words were introduced by monks and learned men, relating to theology and science. Words of Latin origin constitute a very important part of the language, whether introduced directly or through the Norman French. The following is the development of the Latin portion of the language: 1, stem verbs, or roots, as *bib*, *carp*, *cede*, *urge*; 2, stem adjectives, as *bland*, *brute*, *breve* (short); 3, stem substantives, as *arc*, *barb*; 4, primary derivatives, as *final*, *factor*; 5, secondary derivatives, as *valuable*, *moderate*; 6, derivative words with prefixes, as *abode*, *allude*; 7, compound words, such as *leopard*.—*The Anglo-Saxon Element.* Whether we take into view the number or the sorts of words, the Anglo-Saxon is less an element than the mother tongue of the English. In the English language there are about 38,000 distinct words, of which some 23,000 in common use are from this source. The names of the greater part of the objects of nature, as *sun*, *moon*, *day*;

all those words which express bodily action, as *to stand*, *to stagger*; all those words which are expressive of the earliest and dearest connections, as *father*, *mother*, *brother*, *sister*, are Anglo-Saxon. Most of those objects about which the practical reason is employed in common life, nearly all English pronouns, a large proportion of the language of invective, humor, satire, and colloquial pleasantry, are Anglo-Saxon. English grammar is occupied almost exclusively with what is of Anglo-Saxon origin. The English genitive, the general mode of forming the plural of nouns, and the terminations by which we express the comparative and the superlative of adjectives (*er* and *est*), the inflections of the pronouns and verbs, and the most frequent termination of adverbs (*ly*), are all Anglo-Saxon; so are the auxiliary verbs. In fact, the Anglo-Saxon imparted so much of itself to the language, that the proximate origin of our tongue is to be sought in Germany, and its remote origin in central Asia, where was spoken the primitive tongue which may be regarded as the parent of the affiliated Indo-European languages, spoken by the successive tribes which migrated westward into Europe. The natural development of the Anglo-Saxon portion of our language has been nearly as follows: 1, instinctive forms and pronominal elements, as *ah*, *oh*; 2, stem words or roots, as *bend*, *swim*; 3, stem nouns, as *blank*, *band*; 4, reduplicate forms, as *chit-chat*, *sing-song*; 5, primary derivatives, as *chatter*, *toilsome*; 6, secondary derivatives, as *carefully*, *tiresomeness*; 7, words with prefixes, as *arise*, *forbid*; 8, compound words, as *earthquake*, *pick-purse*; 9, disguised compounds and derivatives, as *daisy*, *not*.—*The Danish Element.* Many hundred words, especially names of places, are Danish, introduced during the incursions and occupation of England by the Danes. A portion of these words are provincial, being confined to the northern and northeastern counties of England, the regions most exposed to Danish visitation.—*The Anglo-Norman Element.* An etymological analysis of the language shows that the Anglo-Norman element enters very largely into its composition. This element, which is composed of the Celtic, the Latin, and the Scandinavian, was first introduced (1066) by the Normans, under William the Conqueror. Norman French was spoken by the superior classes in England from the conquest to the time of Edward III. (1327). The laws and the proceedings in parliament and in courts of justice were in that language. In the 13th century, during the progressive mixture of the two races, a literature sprang up in which the two languages were more or less blended. In the 14th century the Anglo-Saxon element seemed to have gained the upper hand. In the 15th the Anglo-Norman seemed to be gaining the preponderance; but the proportions still continued to vary until it became fixed in the age of Elizabeth. Words were generally adopted into the common lan-



guage from the Anglo-Norman or the Anglo-Saxon, according as the objects or ideas expressed by those words belonged more exclusively to one race or the other. Thus the names of common articles of dress are Anglo-Saxon, as *shirt, breeches, hose, shoes, hat, cloak*; but other articles subject to changes of fashion are Anglo-Norman, as *gown, coat, boots, mantle, cap, bonnet*. The word *house*, a common residence, is Anglo-Saxon; but *palace, castle, manor, and mansion* are Anglo-Norman. The names *ox, calf, sheep, pig, boar* are Anglo-Saxon, because that part of the population were engaged in tending those animals while they were living; but *beef, veal, mutton, pork, venison* are Anglo-Norman names, because that part of the population were accustomed to eat their flesh when they were killed. The natural development of the Anglo-Norman or Romanic portion of the language is nearly as follows: 1, verbal roots in English, as *boil, cay* in decay, *ceive* in conceive, *pound, vouch*; 2, stem adjectives, as *chaste, clear*; 3, stem substantives, as *beast, peace*; 4, derivative words with suffixes, as *flourish, authorize, volunteer, arabesque, plumage, journal, service, fashion*; 5, derivative words with prefixes, as *avouch, antechamber, countermark*; 6, Romanic compounds, as *portfolio, wardrobe*; 7, disguised Romanic words, as *biscuit, bachelor, proctor, curfew*. The common statement is that Anglo-Saxon was converted into English: 1, by contracting and otherwise modifying the pronunciation and orthography of words; 2, by omitting many inflections, especially of the noun, and consequently making more use of articles and auxiliaries; 3, by the introduction of French derivatives; 4, by using less inversion and ellipsis, especially in poetry.—Besides the languages already mentioned which have contributed to the composition of the English, several others, and especially the Greek, should also be mentioned: 1, Greek verbal roots, as *arch*, in archetype, *graph* in graphic; 2, stem adjectives, as *kal*, beautiful, in calligraphy, *kryph*, hidden, in apocrypha; 3, stem substantives, as *rhomb, cord*; 4, derivative words with suffixes, as *poet, christm*; 5, secondary derivatives, as *Baptist, Christian*; 6, derivative words with prefixes, as *apoplexy, catarrh, catastrophe*; 7, compounds, as *democracy, pedagogue*. There are also in the language Hebrew words, as *manna*, a gum, *jasper*, a precious stone, *sabbath*; Spanish, as *guerilla, matadore*; Italian, as *stanza, piazza*; Persian, as *bazaar, chess*; Arabic, as *alembic, gazelle*; Chinese, as *chop, hyson*; and Indian, as *hominny, moccason*. Our terms in polite literature come from Greece; in music and painting, from Italy; in cookery and war, from the French; and in navigation, from the Flemings and Dutch.—From its composite character, the English is copious in its vocabulary and phrases. There are large classes of words derived from the Norman or the classical languages which are in common parlance sy-

nonymous with words derived from the Anglo-Saxon. General terms are from the Latin; those that denote the special varieties of objects, qualities, and modes of action are from the Anglo-Saxon. Thus, *color* is Latin; but *white, black, green* are Anglo-Saxon. It has been remarked that "Latin furnishes the elegant, the Saxon the common expression, as *bad odor* and *stench, perspiration* and *sweat*." In looking through the several stages of the language, namely, the Saxon, the semi-Saxon, the old English, the middle English, the modern English, we are struck with the constant death of old words, and the constant birth of new ones that come in to fill their places. In the early periods this was due to the successive interruptions of foreigners, who in introducing their own language necessarily expelled a portion of the vernacular. Another cause of these mutations is that the pursuits of the English people have been multiform beyond those of any other nation, and the language has correspondingly changed. Lexicographers, in their zeal to introduce new words, to the neglect of old ones, have contributed to the changes by recording the one class and omitting the other. In Halliwell's "Dictionary of Archaic and Provincial Words" there are more than 50,000 words not recorded in modern dictionaries.—For further information on this subject the reader may consult Grimm's *Deutsche Grammatik* (4 vols., Göttingen, 1819-'37); Guest's "History of English Rhythms" (London, 1838); Rask's "Anglo-Saxon Grammar," translated by Thorpe (London); Bopp's "Comparative Grammar," translated by Eastwick (3 vols. 8vo, London); Trench's "English, Past and Present" (New York ed., 1855), and "Study of Words" (New York ed., 1861); Gould Brown's "Grammar of English Grammars" (New York, 1857); Latham's "Hand-Book of the English Language" (New York ed., 1857); Fowler's "English Language in its Elements and Forms" (New York, 1859); G. P. Marsh's "History of the English Language" (New York, 1862); Alford's "Queen's English" (London, 1864); Earle's "Philology of the English Language" (Oxford, 1867 and 1871); March's "Comparative Grammar of the Anglo-Saxon" and "Introduction to Anglo-Saxon" (New York, 1870); Stormonth's "Etymological Dictionary of English" (Edinburgh and London, 1871); Morris's "Historical Outlines of English Accidence" (London, 1872); and R. G. White's "Words and their Uses" (New York, 1870 and 1873).—ENGLISH LITERATURE was preceded in the British islands by compositions in the Cymric or ancient British, Anglo-Saxon, Anglo-Norman or early French, and Latin languages. A few Cymric metrical pieces are extant, which date probably from the 6th century; they are the songs of the Welsh bards Aneurin, Taliesin, Llewarch-Hen, and Myrddin, the sage as well as poet, whom succeeding centuries transfigure into the enchanter Merlin. To Gildas, a brother

of Aneurin (or in the opinion of some identical with him), is attributed a Latin prose tract, *De Excidio et Conquestu Britannia*, which if genuine is the earliest historical work produced in Britain that has been preserved. The personages mentioned in these eldest British songs and annals, as Arthur, Merlin, Kay, and Gawain, played prominent parts in romantic literature a few centuries later, and still afford favorite themes for the poets. During the Anglo-Saxon period both a vernacular and a Latin literature were cultivated, their most flourishing era being the 8th century, the age of Alcuin, Aldhelm, Bede, and Ceolfrid. The monasteries of England and Ireland sent forth many scholars of European celebrity for learning, and Alcuin and Erigena served especially to associate these countries with the continent in liberal studies. The alliterative, unrhyming versification of the Anglo-Saxons was employed in some of the early English poems. But the Norman conquest almost abolished the use of Anglo-Saxon in writing, and for more than a century the prevalent literature of England was either in Latin or in Anglo-Norman. Lanfranc and Anselm, who were attracted from France by the conqueror, and became successively archbishops of Canterbury, originated or revived the scholastic philosophy, the treatises on which were in Latin, and several of the most eminent later doctors of which, as Alexander of Hales, Duns Scotus, and William Occam, were of British birth. Roger Bacon is especially remarkable for his acquaintance with Hebrew and Arabic literature, and quotes from ten of the most highly reputed Saracen authors. In connection with him may be mentioned Michael Scotus, the wizard of the northern ballads, whose writings were celebrated throughout Europe. The scholastic writers of the 12th century prided themselves on their epistolary style, and many collections of their letters have been preserved, which are among the most valuable illustrations of the public and private history of the time. These letters begin with Lanfranc, were very numerous in the reign of Henry II., and among the most interesting of them are those of Peter of Blois, which contain graphic descriptions of the manners and characters of the time. Latin poems abounded throughout the 12th century, and those of Laurence of Durham, John of Salisbury, John de Hauteville, Nigellus Wirker, and Alexander Neckham contain passages of almost classic elegance. The most ambitious attempts were by Joseph of Exeter, who wrote two epics in heroic measure. A new style of versification, in which rhymes took the place of the ancient metres, was introduced, and soon attained an attractive energy and sprightliness. It was brought to perfection in the satirical poems attributed to Walter Mapes, which exhibit excellent sense and humor amid bacchanalian jovialities. In his *Confessio Goliae* is found the famous drinking song beginning *Meum est pro-*

*positum in taberna mori*. This kind of poetry became extremely popular, and flourished long after the style of the more serious Latin authors had become hopelessly debased. But the most important Latin works during the Norman period were the chronicles or histories, all of them by ecclesiastics. The chronicle of Ordericus Vitalis, which comes down to 1141, was the first in which history was made an object of laborious research; that of William of Malmesbury is the most elegant, and that of Geoffrey of Monmouth exerted the greatest influence on subsequent literature, becoming one of the cornerstones of romantic fiction. It narrated Welsh and Armorican traditions of British history from Brutus, an imaginary son of Æneas, to Cadwalladr in the 7th century. Ingulphus, Henry of Huntingdon, Giraldus Cambrensis, Roger de Hoveden, Matthew Paris, and Jocelin de Brakelonde are perhaps the other most important names in the long catalogue of monkish chroniclers. The earliest Anglo-Norman compositions extant are supposed to belong to the first part of the 12th century. In the reigns of Stephen and Henry II. a school of poets was formed devoted to versifying history in that language, the three great masters of which were Wace, Gaimar, and Benoît de Sainte-Maure. Wace translated Geoffrey's British history into Anglo-Norman verse, under the title of the *Roman de Brut*, which extends to over 15,000 lines; and also wrote the *Roman de Rou*, giving the legends concerning Rollo the Norman. Gaimar made a metrical continuation of the narrative of Geoffrey to the Norman period; and Benoît composed a romance of the history of Troy, which upheld the claims of several of the western nations to a Trojan origin. The cycle of romances relating to Arthur and the round table were prevalent in England from the 11th to the 14th century. They were in French, but several of them, as the *Merlin*, *Lancelot*, *Queste du Saint Graal*, and *Mort d'Arthur*, were written by Englishmen for the English court and nobles. Some writers have maintained also that the lays of Marie and the romances concerning Charlemagne and his paladins appeared in England earlier than in France. The original source of these fictions, and of romantic poetry in Europe, is attributed by Bishop Percy to the Scandinavians through the Normans, by Warton to the Arabians through the Moors of Spain, and by Ellis and Turner to the inhabitants of Armorica or Brittany.—During this prevalence of Latin and Anglo-Norman literature the Anglo-Saxon language had been confined to the conquered race, but the "Saxon Chronicle" had been carried on in obscure monasteries by various annalists to the year 1154. About 50 years later, when the two races began to unite in one nation, a work appeared written in Anglo-Saxon so much modified by French that it is usually accounted the beginning of English literature. This was

Layamon's translation of Wace's *Roman de Brut*, which was followed in the 13th century by many translations from Latin and Anglo-Norman. The older chronicles were more or less closely followed in the English metrical pieces of Robert of Gloucester and Robert Manning, a monk of Bourne. The Anglo-Norman romances were reproduced in the English metrical romances of "Sir Tristrem," "Sir Perceval of Galles," "Ywayne and Gawayne," "Havelok the Dane," "King Horn," "Cœur de Lion," "King Alesaunder," "Morte Arthure," "Sir Guy," the "King of Tars," and many others. "Sir Tristrem," one of the oldest, was attributed by Sir Walter Scott, on grounds now generally admitted to be unsatisfactory, to the Scottish poet Thomas the Rhymer. The body of Latin tales entitled *Gesta Romanorum*, perhaps of German origin, was now and continued much later to be a source of materials for English authors. The first original English poet, who left the beaten track of translation from chronicles, romances, and legends of the saints, was Laurence Minot (about 1350), the author of some short ballad-like poems on the victories of the English armies in the reign of Edward III. Richard Rolle, a hermit of Hampole, produced about the same time a moral poem entitled "The Pricke of Conscience." The most remarkable production before the age of Chaucer is "The Vision of Piers Ploughman," ascribed to Robert Langlande. It is in alliterative verse, without rhyme, abounds in allegorical personifications, and is a satire on the vices of the times and especially of the ecclesiastics. It has passages of humor and extraordinary poetical vigor, but the author adopted an obsolete and unrefined diction. Its popularity caused many imitations to be made of it, the best of which was "Piers Ploughman's Crede." Contemporary with Chaucer was Gower, whose *Confessio Amantis*, in octosyllabic metre, is a collection of stories and of physical and metaphysical reflections. Chaucer calls him the "moral Gower," and his poetry is of a grave and sententious turn, professedly serious and instructive. Both in genius and style he is much inferior to Chaucer (died in 1400), the first great English author, admirable for the comprehensiveness and variety of his powers. A courtier and traveller, he was one of the earliest English writers who was not an ecclesiastic, and he excels especially in narrative and in portraiture of character. He introduced and employed with facility the regular iambic pentameter, or heroic couplet, the most approved English metre. The prologue to the "Canterbury Tales" is unsurpassed as a description of character and manners, and the "Knight's Tale" is among the noblest of chivalrous romances. Chaucer has been compared to the appearance of a genial day in spring, preceded and followed by dark clouds and wintry blasts. After him there is a barren period of more than a century; an age of dis-

puted successions and civil wars, when, says an old historian, "the bells in the church steeples were not heard for the sound of drums and trumpets." Till the accession of Elizabeth, the best of numerous versifiers are John the Chaplain, Oclever, Lydgate, Haws, Skelton the laureate, his rival Barclay, the earl of Surrey, Sir Thomas Wyatt, George Gascoyne, Thomas Tusser, and Thomas Sackville, afterward Lord Buckhurst. Of this series, Surrey (died in 1547) is most esteemed as an improver of English verse. He is said to have made the tour of Europe in the spirit of chivalry, proclaiming the unparalleled charms of his mistress Geraldine, and returned to England distinguished as the most devoted lover, learned nobleman, and accomplished gentleman of his age. In his verses he copied the simplicity and grace of the Italian poets, avoiding learned allusions or elaborate conceits, and naturalized the sonnet in England. He also gives the earliest example of blank verse. Wyatt co-operated with him in seeking the elegances of composition; but he embarrassed his songs and sonnets with witty and fanciful conceits. John Heywood is remembered only for his interludes, but he wrote also 600 epigrams, and his most labored performance, "The Spider and the Flie," is pronounced by Warton to be the most tedious and trifling of apologues, without fancy, meaning, or moral. A remarkable poem of this time is the "Mirroure for Magistrates," written by a combination of authors, the chief of whom was Sackville. He furnished alone its most valuable portion, the "Induction" or prologue, an imitation of Dante, marked by a monotony of gloom and sorrow, but showing both grandeur of imagination and power of language. Spenser's "Faery Queen" appeared in 1590. He had already established his reputation by his "Shepherd's Kalendar," published the year before. The "Faery Queen," although unfinished, is really complete in its first book, every canto of which teems with beauties. The following books are altogether inferior, and are rather supplementary, personifying the struggles of the virtues with their opposite vices. The poem, after the fashion of the reign, flatters Elizabeth under the characters of Gloriana and Belphebe. Its peculiar stanza, to which Spenser's name has been given, a modification of the Italian *ottava rima*, with the addition of an Alexandrine to give a full and sweeping close, was an innovation in the art of poetry, and has since been much used. Contemporary with Spenser was Sir Philip Sidney, whose songs and sonnets deserve mention; and either contemporary or soon following were the "Saint Peter's Complaint" and "Mary Magdalene's Funeral Tears" of Robert Southwell; the "Civil Wars," "Complaint of Rosamond," and numerous minor pieces of Samuel Daniel, of a pensive character, and in remarkably pure style; the "Barons' Wars" and the "Poly-olbion" of Michael Drayton, the former a metrical chronicle, and the latter

an immense piece of metrical topography, which contains also striking national legends and ingenious allegorical and mythological inventions; the few and brief poems of Sir Henry Wotton; the *Nosce Teipsum* and the "Orchestra" of Sir John Davies, the former a happily condensed piece of metaphysical reasoning; the satires of Bishop Hall, published in 1597, the earliest in the language except the "Steele Glas" of Gascoyne; the satires, elegies, and various lyrics of John Donne, which are rather metrical problems than poems, strongly manifesting the metaphysical tendency then common in poetry, but which reveal a subtle intellect and fruitful fancy, though obscure in thought, rugged in versification, and full of as bad affectations and conceits as are to be found in the century; the poems of the brothers Phineas and Giles Fletcher, the principal of which are "The Purple Island," an allegorical description of the human soul and body, and "Christ's Victory and Triumph," a beautiful religious composition; and the sacred poems of the country parson, George Herbert. The ballad literature of England and Scotland is of uncertain date, but much of it, as "Chevy Chase," "The Nutbrowne Mayde," and the numerous ballads about Robin Hood, probably arose in the 15th and 16th centuries. Its golden era was the time of Mary, queen of Scots. Scotland meanwhile had a succession of genuine poets, Barbour (died about 1396), who wrote an epic entitled "The Bruce," having been followed by Wynthoun, Blind Harry, Gawin Douglas, and William Dunbar.—The annals of the British drama begin with miracle plays, which are first mentioned as being represented in London in the latter part of the 12th century. They were on sacred subjects, usually from the Bible, were written and to a late period acted by ecclesiastics, and were at first performed in churches and the chapels of monasteries. They were performed on holy days in the largest towns, the most famous and frequented being those of Chester, Widkirk, and Coventry. At Chester they continued every Whit-Sunday, with some interruptions, from 1268 to 1577, and were in Latin or French till in 1338 Higden "obtained leave of the pope to have them in the English tongue." The most ancient extant miracle play in English is at least as old as the reign of Edward III. It is founded on the 16th chapter of the apocryphal gospel of Nicodemus, is entitled "The Harrowing of Hell," and consists of a prologue, epilogue, and intermediate dialogue between nine persons, among whom are Dominus, Satan, Adam, and Eve. Besides this and a few other single pieces, there are three distinct sets of them: the Townley collection, 30 in number, supposed to have belonged to Widkirk abbey, before the suppression of the monasteries; the Coventry collection, performed in that city on the feast of Corpus Christi, 42 in number; and the Chester Whitsun collection, 30 in number. Miracle

plays were transformed into moral plays by exchanging Scriptural and historical characters for abstract, allegorical, or symbolical impersonations. This sort of religious drama was in a state of considerable advancement in the reign of Henry VI., and reached its highest perfection in that of Henry VII. Two prominent personages in them were the Devil and a witty, mischievous, profligate character, denominated the Vice. "By the relinquishment of abstract for individual character," says Mr. Collier, "they paved the way, by a natural and easy gradation, for tragedy and comedy, the representations of real life and manners." John Heywood, the epigrammatist, who belonged to the court of Henry VIII., contributed to driving Biblical and allegorical personages from the stage, and his plays form a class almost by themselves, termed interludes. The later plays of Bishop Bale also belong to the period of transition, and he was the first to apply the name tragedy and comedy to English dramatic representations. The earliest comedy is the "Ralph Roister Doister" of Nicholas Udall, and is at least as ancient as the reign of Edward VI. It has 13 characters, 9 male and 4 female, represents the manners of polished society, and could not be performed in less than 2½ hours. It is superior to "Gammer Gurton's Needle," by John Still, the second in point of time, which was acted at Cambridge university in 1566, and contains the first drinking song of any merit in the language. The earliest extant piece that can be called a tragedy is the "Ferrex and Porrex" of Thomas Sackville and Thomas Norton, afterward named "The Tragedy of Gordobuc," which is in regular blank verse, consists of five acts, and was played before Queen Elizabeth at Whitehall, Jan. 18, 1562. During a part of the reign of Elizabeth miracle plays, moral plays, and romantic dramas were prevalent together. The custom of acting Latin plays in the universities of Oxford and Cambridge continued till Cromwell's time.—From the middle of the reign of Elizabeth to the accession of Anne (1580–1702), and more particularly to the great rebellion (1580–1642), may be reckoned the period of the so-called old English authors. The more limited era is unsurpassed in force, variety, and originality of literary genius in the annals of the world. Among the influences which excited vast intellectual and moral activity were the study of the classics and of the literatures of Italy and France, the discovery of America and of the true theory of the solar system, the reformation, the practical results then following from the invention of gunpowder and of printing and from the overthrow of feudalism, the assertion of individual rights, and the enthusiastic sense of national independence and power. New ideas and interests aroused the minds of men, and the old forms and institutions, disappearing from actual life, lingered in the imagination and were idealized in poetry. The language rapidly grew to a

strength and affluence which Dr. Johnson declared adequate to every purpose of use and elegance, while a masculine vigor, sometimes coarse, sometimes highly delicate, marked all the diversities of character and culture. The most extensive and important department of literature during this epoch was the drama, which distinguishes that age from all preceding and less decisively from all subsequent periods. It had two distinct periods, that of the old English dramatists (in the narrowest use of the term) prior to the civil war, and that of the comic dramatists after the restoration. In the former series the most eminent names are Marlowe, Shakespeare, Ben Jonson, Beaumont and Fletcher, Chapman, Decker, Webster, Marston, Massinger, Ford, Thomas Heywood, and Shirley. Among the precursors of Shakespeare were also John Lilly, whose nine plays, and especially "Endimion," have always had admirers for their dainty and conceited style; Thomas Kyd, whose "Spanish Tragedy," improved by Jonson, is said to have gone through more editions than any other play of the time; Thomas Nash, a ribald satirist; Robert Greene, whose comedies are lively, fantastic, and florid, and whose "Friar Bacon and Friar Bungay" is one of the latest plays in which the devil appears in person; George Peele, whose "David and Bethsabe" has been termed the earliest fountain of pathos and harmony in English dramatic poetry; and Thomas Lodge, who was associated with Greene in writing "The Looking-Glass for London and England," a strange performance, in which the prophecy of Jonah against Nineveh is applied to the city of London. All of these abound in bombast and pedantic classical allusions. A more potent spirit was Christopher Marlowe (1564-93), who, throwing off the shackles of rhyme, gave to blank verse an easy modulation and rhythm, and amid much rant and buffoonery produced some scenes and passages of wonderful beauty and grandeur. His most admired plays are "The Jew of Malta," "Edward II.," and "The Life and Death of Dr. Faustus," the last of which best illustrates the "fine madness" of his character. An awful melancholy pervades the fiend Mephistopheles, more impressive than the malignant mirth ascribed to him by Goethe. Marlowe was the immediate precursor of William Shakespeare (1564-1616), a comparison of whose works with those of his contemporaries proves his superiority as much in judgment and taste as in creative power, for a large proportion of his plays are more regular than any other prior to the close of the civil wars. The rules of the classical dramatic art were not then in vogue; the French neo-classical drama had not been originated; and though Shakespeare violated the ancient unities of time and place, he observed almost universally the unity of feeling and of interest. The soundest criticism has vindicated for him the character of a profound artist as well as a great and luxuriant genius, and his peculiar

excellences appear in the marvellous variety and verisimilitude of his personages, in the skill with which opposite characters are grouped and the finest and most diversified threads woven into a harmonious web, and in the completeness with which the entire action as well as the several characters is worked out, minute features and particulars being poetically conceived with reference to the universal system of things. Shakespeare's plays are 34 in number (the authorship of some of which, however, is disputed), and are usually divided into tragedies, comedies, and histories. Since the beginning of the present century their supremacy has attained unqualified and intelligent recognition. A friend of Shakespeare and his associate in the Mermaid, the oldest of clubs, was Ben Jonson (1574-1637), one of the most familiar names among the old dramatists. He had scholarly acquaintance with the classics, and labored to make the laws of the ancients authoritative in English dramatic art. He is the author of two tragedies, "Catiline" and "Sejanus," and of numerous comedies and masques, the best of which are "The Alchemist," "Volpone, or the Fox," and "The Silent Woman." They are full of solid materials, in a stately, eloquent, but often pedantic style, and seem to have been produced slowly and upon deliberation, the wit, fancy, and satire being severely elaborated. His poetical character appears in its most pleasing aspect in the lyrical verses with which his masques are varied and enlivened, especially in the pastoral drama of "The Sad Shepherd," which display an admirable taste and feeling, and have all the charms of song. Jonson may have aimed at an audience of men of sense and knowledge, but Beaumont and Fletcher wrote for men of fashion and the world. Of the 52 plays published under their joint names, Beaumont may have had a part in only 17. They are keen, vivacious, and often elegant, but slight and superficial in comparison with Shakespeare's and Jonson's; the songs scattered through them are, however, among the most beautiful in the language. The dramas of George Chapman (1557-1634), the translator of Homer, contain "more thinking" than those of most of his contemporaries; they have many passages of striking grandeur, are in a lofty and extravagant style, and their contemplations on the nature of man and the world leave impressions favorable to moral excellence. The "Fortunatus" and "Honest Whore" of Thomas Decker have graceful and genial passages; and the "Duchess of Malfy" and "White Devil" of John Webster are full of horrors cleverly managed, and have been esteemed among the most striking tragic productions of this period. The modern reputation of Thomas Middleton rests chiefly on his "Witch," which may have suggested to Shakespeare the supernatural scenery in "Macbeth;" and the coarse plays of John Marston abound in murders, ghosts, and scornful satire. The tragedies of Philip Massinger (1584-1640) have

an easy and majestic flow. "The Duke of Milan" and "The Fatal Dowry" are among the best; and of his comedies, "The Picture," "The Bondman," and "A Very Woman." His "New Way to Pay Old Debts" still keeps the stage, for which it is indebted to its effective character of Sir Giles Overreach. John Ford (died about 1640) preferred dark vices and the deepest distress for subjects. He seems to have taken pleasure in revolving the various possibilities and revenges of sin, and the best of his plays bears the title of "The Broken Heart." Thomas Heywood, an indefatigable and popular dramatist, wrote "beautiful prose put into heroic metre." James Shirley (died in 1666) is the last of this circle of dramatists, and the least remarkable either for merits or faults. Under the commonwealth, and the ascendancy of the Puritans, the theatres were closed and the players flogged. Sir William Davenant tried to introduce a modification of the drama suited to the moral views of the time, but with only partial success. At the restoration the drama was revived under the influence of French rules and of a strong anti-Puritan reaction, with great mechanical improvements, movable decorations, music, and lights; but the larger part of the plays for 40 years are declared by Macaulay to be a disgrace to the English language and the national character. To ridicule and degrade virtue, sincerity, and prudence was the business of the stage. Blank verse was displaced by rhyme, but the tragic authors soon returned to the former, and the comic sank to familiar prose. The best tragedies of the period are "The Orphan" and "Venice Preserved" of Thomas Otway (1651-85); and though the former displeases the delicacy of our age, the latter has been more frequently represented than any other tragedy except those of Shakespeare. The genius of the poet appears especially in pathetic delineations of passion and misery, and few heroines have been so highly honored with the tribute of tears as Belvidera in "Venice Preserved." John Dryden, who was rivalled by none of his contemporaries as a satirical, didactic, and lyric poet, abused his rare gifts to attain dramatic success, the faculty for which nature had denied him. His "Don Sebastian," "Spanish Friar," and "All for Love" are the best of numerous tragedies and comedies, whose bombast and ribaldry have rendered them obsolete, notwithstanding their surprising incidents, statey declamation, and harmonious numbers. The "Fatal Discovery" of Southerne, the "Jane Shore" of Rowe, the "Mourning Bride" of Congreve, and the "Rival Queens" of Lee may also be mentioned among successful tragedies. The proper representatives of the comedy of this period are Wycherly, Congreve, Farquhar, and Vanbrugh, and among their profigate plays the most popular were "The Plain Dealer" and "The Country Wife," "Love for Love" and "The Way of the World," "The Beaux Stratagem" and "The Trip to the Ju-

blee," and "The Provoked Husband" and "The Provoked Wife." Mrs. Aphra Behn, Thomas Shadwell, and Sir George Etherege also deserve mention among those who made the stage as immortal as their talents permitted. The "Careless Husband" and other plays of Colley Cibber, and the "Busy Body" and "Bold Stroke for a Wife" of Mrs. Centlivre, connect the period of the restoration with that of Anne. Among the non-dramatic poems of the Elizabethan age, mention should be made of the translation of Ovid and Lucan by Marlowe; Sandys's versions of Ovid and the Psalms; Harrington's version of Ariosto, Fanshawe's of Camoëns, and the more important versions of Homer by Chapman and of Tasso by Fairfax.—The literary genius of the age of Puritan ascendancy, between the Elizabethan epoch and that of the restoration, culminated in Milton, who has no rivals in epic poetry but Homer, Virgil, and Dante. His career illustrates the literary character of his age. Prior to 1640 he had produced "L'Allegro," "Il Penseroso," "Comus," "Lycidas," and the "Ode on the Morning of the Nativity," one of the finest in the language. During the period of civil conflict and Cromwellian rule, from 1640 to 1660, he wrote no poetry except a few sonnets, but produced his various polemical prose treatises; and it is remarkable that there was at that time an almost entire cessation of pure literature in England. The contemporary poets, without an exception of any consequence, had their eras of activity only before the struggle and after it, or in exile or in prison during it, and the intellect of the country was occupied in producing a huge mass of controversial prose, only a very slight portion of which has taken a place in the literature. One literary man only was undisturbed and uninterested by the events of the time. While England was in political and religious confusion, Sir Thomas Browne was quietly meditating in his garden at Norwich upon sepulchral urns and the quincunial lozenge. "Paradise Lost," though published after the restoration, was an early conception of Milton, and bears the impress of this period of fierce discussion and of moral and theological strife. Its subject, the fall of man, is perhaps without an equal in epic grandeur, and its most prominent personage, if not its hero, is the fallen archangel Satan, whose ruined splendor and power of daring and of suffering make him one of the sublimest creations of poetry. The latest poems of Milton, "Paradise Regained" and "Samson Agonistes," are of inferior worth. Among the contemporaries of Milton were Thomas Carew, Francis Quarles, George Wither, Sir John Suckling, Robert Herrick, Richard Lovelace, Sir Richard Fanshawe, Richard Crashaw, Abraham Cowley, Henry Vaughan, Sir John Denham, Sir William Davenant, Edmund Waller, and Samuel Butler. The songs and short amatory pieces of Carew were the precursors of numerous similar productions written by

gay and accomplished cavaliers and courtiers, as the "Ballad upon a Wedding" and many other poems of Suckling, admirable for their witty levity; the odes and songs of Lovelace; the miscellaneous poems of Fanshawe; and, superior to all others, the graceful occasional poems of Cowley and Waller. The melodious verse of Waller was especially admired, and was diligently studied by Pope. Cowley (1618-67), though full of metaphysical conceits, was the most popular poet of his time. His Anacreontics, the happiest of his pieces, are lively, joyous, and charmingly embellished. The "Cooper's Hill" of Denham is at once meditative, vigorous, and rhythmical, and the "Gondibert" of Davenant was for a time regarded as a monument of genius. The religious poems of Quarles, Crashaw, and Vaughan may be classed together. The productions of Herrick and Wither exhibit playfulness of fancy and delicacy of sentiment, varied in the former by frequent grossness and indelicacy. Butler's "Hudibras," a work of inexhaustible wit, which was perpetually quoted for half a century, belongs chronologically, as do many of the later poems of Milton and his contemporaries, to the age when Dryden (1631-1700) and the comic dramatists were prevalent. Dryden's rapidity of conception and ease of expression made him a voluminous contributor to various departments of literature. The greatest of his satires are "Absalom and Achitophel" and "Mac Flecknoe," and the first lines of his fine controversial poem, "The Hind and Panther," are among the most musical in the language. His various, though not his greatest, excellences appear in his "Fables" and his "Ode for Saint Cecilia's Day." Among his contemporaries, a few of whose poems still survive, were Marvell, Rochester, Charles Cotton, Sedley, John Phillips, Oldham, Rosecommon, Mulgrave, Dorset, and Pomfret.—English prose begins with Sir John Mandeville's narrative of his travels, written in Latin, French, and English, soon after his return to England in 1355. It is a medley of his own observations, with ancient fables and the marvels reported by other travellers. Nothing like the excellence of later English prose was produced for the next century and a half, during which time Trevisa translated Higden's Latin *Polychronicon*. Wycliffe began to show the copiousness and energy of the language in his translation of the Bible. Chaucer composed two of the Canterbury tales and two other works in prose. Bishop Peacock wrote in favor of reason rather than constraint as a means of bringing the Lollards within the pale of the Catholic church. Tiptoft translated Cicero's *De Amicitia*. Lord Rivers became an author by his "Dicts of Philosophers," and Sir John Fortescue (died about 1480) surpassed all of his predecessors in the style of his treatise on "The Difference between an Absolute and a Limited Monarchy." The first book printed in England is supposed to have been "The Game of Chess,"

by Caxton, in 1474. As an author, by translating from the French, and often by continuing the works which he printed, Caxton probably exerted a greater influence on prose literature than any other individual between Chaucer and the reign of Henry VIII. Chroniclers nearly contemporary with him were Robert Fabyan and Edward Hall. A curious collection of letters has been preserved, written by members of the Paston family in the reigns of Henry VI., Edward IV., and Henry VII., which forms the oldest body of private letters in any modern European language. To the reign of Henry VIII. belongs Sir Thomas More's "History of Edward V.," the first example of a pure and perspicuous prose style. His *Utopia*, in which he developed his theory of a perfect society, was first published in Latin, and was scarcely excelled in spirit and originality by any previous Latin work written in Europe since the revival of letters. Prior to Elizabeth, or early in her reign, were written also the "Itinerary" of Leland, the "Gouverneur" of Sir Thomas Elvot, the "Art of Rhetorique" of Thomas Wilson, the biography of Wolsey by Cavendish (first printed in 1641), the translations of the Bible by Tynedale and Coverdale, the sermons and letters of Latimer, and the "Toxophilus" of Roger Ascham, who was the first accomplished scholar that composed his chief works in English.—The old English prose writers are generally distinguished for sterling sense, and for a style copious to redundancy. Their diction is deformed by pedantry, their collocation of words and phrases is in imitation of the Latin, and their periods are tediously prolonged and un rhythmically constructed; yet they are nervous and effective, and seldom degenerate into indefinite and aimless phraseology. The most admirable prose writer of the Elizabethan period is Richard Hooker (1533-1600), whose "Ecclesiastical Polity" is one of the masterpieces of English eloquence; and its richness of style and fulness of imagery, united with condensation of thought, was unapproached by any other writer during the next century. The *Novum Organon* of Bacon (1561-1626), the most influential and original philosophical work produced in England, was written in Latin. He compared his "Advancement of Learning," a "globe of the intellectual universe," with a note of those parts not yet improved by the labor of man, to the noise which musicians make in tuning their instruments, "which is nothing pleasant to hear, but yet is a cause why the music is sweeter afterward;" and at the close of his survey he predicted that "the third period of time will far surpass that of the Grecian and Roman learning." His style, usually sententious and somewhat stiff, became more imaginative, richer, and softer with his increasing years; but though his fancy was of the brightest, he allowed to it no other office than that of ministering to reason. His application of thought to purposes of utili-

ty and progress, with a view to the practical restitution of man to the sovereignty of nature, has entered as a characteristic element into the public mind of England. His "Essays" are among the masterpieces of English prose, and are equally eminent for power of expression and for compact and solid wisdom. Contemporary productions were the "Arcadia" and the "Defence of Poesy" of Sir Philip Sidney, the former of which was universally read and admired; the "History of the World" of Sir Walter Raleigh, written in the tower; the "Chronicle of England" and "Survey of London" of John Stow; the chronicles of Raphael Holinshed; the collection of voyages by Richard Hakluyt; the "Purchas his Pilgrims" of Samuel Purchas; the "Relation of a Journey," &c., of George Sandys; the "Epistolæ Hølianae" of James Howell; the "History of the Turks" of Richard Knolles; and the sermons of Bishop Andrews and Dr. Donne, mosaics of quaintness, quotation, wisdom, folly, subtlety, and ecstasy. The writings of John Lilly produced a marked effect on much of the Elizabethan literature. His "Euphues," a dull story of a young Athenian, in a smooth style, full of affected conceits and recondite similes, was the model after which wits and gallants formed their conversation and writing. The ladies of the court were among his pupils, and Blount (1632) remarks that the beauty who could not "parley Euphuisme" was as little regarded as one that could not speak French. Under James I. was produced the translation of the Bible which is still the standard English version, and which did much to make the language of the Elizabethan age the permanent speech of the English people. Between Bacon and Locke, the most acute of English metaphysicians was Thomas Hobbes (1588-1679), whose political theories are collected in his "Leviathan." His style is uniformly excellent, a merit which belongs to none of his predecessors. Among his contemporaries were the skeptical philosopher Lord Herbert of Cherbury, who wrote also a history of the reign of Henry VIII.; the antiquaries William Camden, Sir Henry Spelman, Sir Robert Cotton, and John Speed; John Selden, the author of a "Treatise on Titles of Honor," whose admirable "Table Talk" was published after his death; the chronologist Archbishop Usher; William Chillingworth, whose "Religion of Protestants" is a model of perspicuous reasoning; Peter Heylin, a wit and divine, the author of "Microcosmus;" John Hales, a preacher and controversialist; John Gauden, the probable author of the famous "Eikon Basilike," which professed to have been written by Charles I.; and the two most eloquent of the old English divines, Joseph Hall (1574-1656) and Jeremy Taylor (1613-1667), whose works are monuments of their own abilities and of the pedantic tastes of the age. The "Contemplations" of Hall are superior to any of the writings of

Taylor in continuity of thought, but the latter has perhaps had no equal in the pulpit in the splendor of his imagination, and is often called the Shakespeare of divines. The most curious works of the time are the "Anatomy of Melancholy" of Robert Burton (died about 1640), composed largely of apt and learned quotations from rare authors, constantly intermingled with the writer's own thoughts, which exhibits in every part great spirit and power, and has the charm of a full and vigorous style; and the "Religio Medici," "Urn Burial," and other works of Sir Thomas Browne (1605-1682), elaborately quaint compositions, fascinating from their pensiveness akin to melancholy, their paradoxes, and their occasional subtlety and imaginative brilliancy. Under the head of essays or sketches may be classed the "Gull's Hornbook" of the dramatist Decker, the "Characters" of Sir Thomas Overbury, the "Resolves" of Owen Feltham, the "Microcosmography" attributed to Bishop Earle, the miscellaneous pieces of Sir Henry Wotton, and the "Discourses by way of Essays" of Cowley. The last are written in a perspicuous style, very unlike the affected obscurities of his poems, and may be reckoned among the earliest models of good writing in English prose. John Locke (1632-1704) is the author of treatises on civil government, education, and the reasonableness of Christianity, which diffused a spirit of liberty and toleration in opinion and government; but his most important work is the "Essay concerning the Human Understanding," which was for a time the acknowledged code of English philosophy, and displays and inculcates a careful, tentative observation of intellectual habits. It helped to convert metaphysics from scholastic problems into practical and clearly intelligible analyses, but its indefiniteness in the use of the phrase "ideas of reflection" has left the essential character and tendency of the Lockean system in dispute between sensationalists and idealists. Two writers who at this time deviated from the track which English speculation has chiefly followed, and in whom Platonic tendencies predominated, were Ralph Cudworth, author of "The Intellectual System of the Universe," a vast storehouse of learning and an unrivalled exhibition of subtle speculation, and Henry More, author of "The Mystery of Godliness," "The Mystery of Iniquity," and other works which were once very popular. The sermons of Barrow, South, and Tillotson were respectively esteemed for strength, wit, and unction, but the last have retained least of their former popularity. To this period belong most of the prose writings of Milton, which test the power of the language in vigorous and lofty declamation, the *Origines Sacrae* of Stillingfleet, the theological treatises of Sherlock, the "Exposition of the Creed" of Pearson, the "Exposition of the XXXIX. Articles" of Bishop Burnet, the "Saint's Everlasting Rest" and other works of Baxter, the



expository works of Leighton, Owen, and Henry, and the writings of the Quakers George Fox, Robert Barclay, William Penn, and Thomas Ellwood. This age of divines and comic dramatists was also distinguished for its devotion to practical science under the guidance of the spirit of Bacon, and chemistry and physics became at once fashionable and respected. Instances of this tendency are the "Discovery of a New World" and the other so-called "mathematical works" of Bishop Wilkins, the "History of the Royal Society" of Sprat, the "Sacred Theory of the Earth" of Thomas Burnet, the "Sylva" and "Terra" of Evelyn, the "Observations" and the "Wisdom of God Manifested in the Works of Creation" of John Ray, and above all others, the "Considerations on the Usefulness of Experimental Philosophy," and other works, philosophical and religious, of Robert Boyle, and the *Philosophiæ Naturalis Principia Mathematica* of Sir Isaac Newton. Among antiquarian works were the *Monasticon Anglicanum* of Sir William Dugdale, the *Athenæ Oxonienses* of Anthony à Wood, the history of the order of the garter by Elias Ashmole, the "Miscellanies" of John Aubrey, and the *Fœdera* of Thomas Rymer, who also wrote a curious treatise on tragedy, in which Shakespeare is criticised according to certain stately notions derived from the ancients. Works of high literary interest are the "Worthies of England" of Thomas Fuller, one of the strangest books in the world, a melange of oddity, sagacity, and humor, in a pithy style; the "History of the Rebellion" of Lord Clarendon, which, in spite of its partiality, is admirable for its portraits of character and its animated narrative; the "Observations on the United Provinces of the Netherlands" of Sir William Temple; the histories of the reformation and of his own times by Gilbert Burnet; the "Pilgrim's Progress" of John Bunyan, a specimen of homely English, the fruit of a lively and powerful imagination cultivated only by the study of the Scriptures; and the half poetical "Complete Angler" of Izaak Walton, who also wrote some pleasing biographies. Minor works were the translations and political pamphlets of Sir Robert L'Estrange, the "Contemplations" of Sir Matthew Hale, the "Essays" on ancient and modern learning by Temple, and the "Reflections" in answer to them by Wotton. Tom D'Urfey and Tom Brown, the last of the wits of the restoration, wrote comic and licentious compositions in prose and verse. The "Short View," &c., of Jeremy Collier was the beginning of a controversy between him and the comic dramatists which resulted in the reformation of the theatre.—With the reign of Anne (1702-'14) begins a new era in English composition, when the affluence of the older literature gave way to correctness. The rules of the art were better understood, the style was cleared of its redundances, and wit refined from its alloy. The writers of the Elizabethan period, in an

age of stupendous changes, on the confines between barbarism and refinement, had dealt with the original passions and principles of human nature, and had found their illustrations in the pageantry of past institutions and in dreams of the future. As the English advanced to the character of a polished nation, their literature also became less wild and grand in its romance and more regular in its outlines, the suggestions of genius being moulded by the rules of taste. As enriched and refined by the writers of the reign of Anne, which is often called the Augustan age of the literature, the language was almost finally formed. The fashions and frivolities of elegant and artificial life became the themes of poets and essayists, and while the highest regions of poetry and speculation were abandoned, books were no longer confined to the learned or curious, but were gradually spread among all classes. Men of letters now first became known in England as a distinct class in society. To bring philosophy out of closets and libraries, schools and colleges, and to make it dwell in clubs and assemblies, at tea tables, and in coffee houses, was the task which Steele proposed to himself. That school of poetry which may be traced to the adoption of French rules under Charles II., which acquired stability from the transcendent powers of Dryden, was now perfected by Alexander Pope (1688-1744), and retained its ascendancy nearly through the 18th century. The follies of his feeble copyists have reacted injuriously upon the fame of the great master of the school. For half a century the notion prevailed that whoever deviated from the standard of Pope was worthy only to figure in the "Dunciad;" but somewhat later it became common to deny to him poetic genius, imagination, and versatility, and to decry his wit, epigrammatic force, and faultless numbers, by confounding them with the imitations of those who had caught something of his metre, but nothing of his spirit. His correctness was branded as the badge of unimaginative and artificial verse, and might almost be numbered among the lost arts. Yet Campbell and Byron were zealous to do him justice, and the latter compared the poetry of the 18th century to the Parthenon, and that of his own times to a Turkish mosque. The vigor of conception and point of expression which distinguished the "Essay on Man," the "Rape of the Lock," the "Epistle from Eloisa to Abelard," the "Satires," and the "Dunciad," vindicate for them the highest rank in a peculiar and admirable class of compositions. His "Iliad" and "Odyssey," though un-Homeric, are valuable additions to English literature. The finest contemporary poetical productions were the "Letter from Italy," the "Campaign," and the "Cato" of Addison, the octosyllabic satires and occasional pieces of Swift, the "Shepherd's Week, in Six Pastorals," of Gay, the "Hermit" and the "Night Piece on Death" of Parnell, and the "Gentle Shep-

herd" of the Scotch poet Allan Ramsay. The names of Prior, Tickell, Garth, Blackmore, Ambrose Philips, Somerville, and Anne, countess of Winchelsea, also belong here. It is remarked by Wordsworth that between the publication of "Paradise Lost" (1667) and of the "Seasons" (1730) of James Thomson, with the exception of the "Windsor Forest" of Pope and a passage in the "Nocturnal Reverie" of the countess of Winchelsea, not a single new image of external nature was produced in poetry. "The Seasons" is almost the only memorial which the age has left of poetical sympathy with natural scenery. It was original as well in style as in substance, for its blank verse has an easy flow peculiar to itself. Thomson's "Castle of Indolence" is a successful imitation of the manner of Spenser, and has great and peculiar beauty. The "Night Thoughts" of Edward Young (died in 1765) is also in effective blank verse, dissertational rather than simply poetical, in a sustained imaginative and epigrammatic style. The "Grave" of Robert Blair and the hymns of Watts are serious and devotional compositions of the same time. Through the "Bastard" of Richard Savage, the "London" and "Vanity of Human Wishes" of Dr. Johnson, the eclogues and odes of William Collins, the "Pleasures of Imagination" of Mark Akenside, the odes and the "Elegy" of Thomas Gray, the "Deserted Village" and the "Traveller" of Oliver Goldsmith, the "Minstrel" of James Beattie, the "Botanic Garden" of Erasmus Darwin, and the "Task" of William Cowper, the line of English poetry was continued almost to the commencement of the present century. Johnson and Goldsmith both belonged to the school of Pope; but their poetry has distinctive characteristics, that of Johnson being marked especially by vigor and strong sense, and that of Goldsmith by sweetness and grace. The "Ode on the Passions" and several other pieces of Collins are masterpieces in their kind, and especially remarkable for the pictorial effects produced by the personification of abstract qualities. Collins and Gray were the two finest lyric poets of the century, and Gray's "Elegy written in a Country Churchyard" and his Pindaric ode of "The Bard" are exquisite examples of finished art and poetical vigor. Cowper was the precursor of the regeneration of poetry, and, abandoning the stock images and metrical sing-song with which art and fashion had been described, he produced pictures of English life and scenery marked by a simplicity, freedom, and freshness which anticipated the dawn of a new period. Among the productions of minor poets of the 18th century are the "Grongar Hill" of John Dyer, the "School-mistress" of Shenstone, the "Collin and Lucy" of Tickell, the "William and Margaret" of Mallet, the Scotch songs of Ross, the "Mary's Dream" of Lowe, the "Auld Robin Gray" of Lady Anne Barnard, the "Tullochgorum" of Skinner, the "Tweedside" of Crawford, the

various poems of Ferguson, the odes and the epitaph on his wife of Mason, the odes of Smollett, the "Art of Preserving Health" of Armstrong, the "Cumnor Hall" and the translation of the "Lusid" of Mickle, the "Braes of Yarrow" of Hamilton, the elegies of Hammond, the "Careless Content" of Byrom, the "Country Justice" of Langhorne, the "Lawyer's Farewell to his Muse" of Blackstone, the "Shipwreck" of Falconer, the "Actor" of Robert Lloyd, the "Rosciad" and other satires of Charles Churchill, the brief poems of Thomas and Joseph Warton, the "Leonidas" and "Athenais" of Glover, the short lyrics and translations of Sir William Jones, the "Chameleon" of Merrick, the pastorals of John Cunningham, the "New Bath Guide" of Anstey, and the "Triumphs of Temper" and other works of Hayley. In the latter half of the 18th century also Macpherson produced the pieces which he ascribed to Ossian, Chatterton wrote the poems which he ascribed to Rowley, and Percy collected many old songs and ballads in his "Reliques of English Poetry."—The English drama of the 18th century bore to a considerable extent the impress of the neo-classical school reigning in France, and presented a complete separation of tragedy and comedy. The "Cato" of Addison, the "Elfrida" of Mason, and the "Irene" of Johnson are rather dramatic poems than plays. The "Sophonisba" and four other tragedies of Thomson are the undramatic attempts of a descriptive poet. More successful tragedies were the "Revenge" of Young, the "Barbarossa" of Brown, the "Gamester" of Moore, the "Elvira" of Mallet, and the "Douglas" of Home. In this period were produced the finest examples of English comedy, written usually in prose, and exhibiting refinement of sentiment and wit. The forerunners of the comedies of Goldsmith and Sheridan were the "Conscious Lovers" of Steele, the "Suspicious Husband" of Hoadley, the "Jealous Wife" of the elder Colman, the "Clandestine Marriage" of Colman and Garrick, the "Way to Keep Him" of Murphy, the "False Delicacy" of Kelly, and the "West Indian" of Cumberland. Goldsmith's "She Stoops to Conquer" has every requisite for making an audience merry. The "School for Scandal," the "Rivals," and the "Critic" of Sheridan are distinguished for epigrammatic witticisms, insight into social weaknesses, and ingeniously contrived whimsical situations; and the first is in many respects superior to any other comedy of modern times. The "Lying Valet" and "Miss in her Teens" of Garrick, the "Belle's Stratagem" of Mrs. Cowley, the "Tom Thumb" of Fielding, the "Man of the World" of Macklin, the "High Life Below Stairs" of Townley, the "Devil to Pay" of Coffey, and especially the score of farcical plays of Foote, were the best and most popular comic productions of this epoch.—The prose authors of the 18th century may nearly all be classed as essayists, philosophers, histo-

rians, divines, and novelists. A new and excellent field for essayists was found in the "Tatler," planned by Richard Steele. Periodical papers containing news had existed in England from the time of the civil war, but this was the first periodical designed to have literary merit and to discuss the features and "smaller morals" of society. It appeared three times a week, extended to 271 numbers from April 12, 1709, to Jan. 2, 1711, and each number contained some lively sketch, anecdote, or humorous discussion, and was sold for a penny. It was succeeded by the "Spectator," which appeared every week-day morning in the shape of a single leaf from March 1, 1711, to December, 1712; after a suspension it reappeared three times a week in 1714, and extended to 635 numbers. The "Guardian" was begun in 1713, but became political, and ceased after the 176th number. Steele was the principal contributor to the "Tatler" and "Guardian," and Addison to the "Spectator," but papers were also furnished by Swift, Pope, Berkeley, Budgell, Tickell, and Hughes. The essays, especially those of Addison, were often models of grace, delicacy, and amenity, and were highly influential in correcting and refining the tone of society. Numerous works similar in form and purpose appeared later in the century, of which the only ones that have retained their place in literature are the "Rambler," written almost wholly by Johnson; the "Adventurer," by Hawkesworth, Johnson, and Warton; the "Idler," chiefly by Johnson; the "World," by Moore, Horace Walpole, Lyttelton, and the earl of Chesterfield; the "Connoisseur," by Colman and Thornton, which received also a few essays from Cowper; and the "Mirror" and the "Lounger," both published in Scotland, and supported by a band of literary lawyers, among whom were Mackenzie, Craig, Cullen, Bannatyne, Hailes, Abercrombie, and Tytler. The letters of Lady Mary Wortley Montagu are models of an easy and elegant epistolary style. The two chief philosophical writers of the early part of the century were Bishop Berkeley and the earl of Shaftesbury, and the "Minute Philosopher" of the former is the happiest imitation in English of the dialogues of Plato. The style of his other metaphysical treatises is singularly animated and imaginative. In his "Theory of Vision" he advanced novel and ingenious views on optics, which are now universally adopted. His doctrine of idealism, the object of which was to prove that nothing exists but God and ideas in the mind, marked an era in English philosophy. The "Characteristics" of the earl of Shaftesbury, once greatly admired for their moral and religious sentiments, and their elegant though affected diction, are now little read. He suggested the theory of a "moral sense," which was adopted and illustrated by subsequent Scottish philosophers. The levity with which he sometimes alluded to Christian doctrines great-

ly impaired his influence. A similar levity is even more apparent in the letters of Lord Bolingbroke, who was long considered a master of written eloquence. A notable work of this period was Warburton's "Divine Legation of Moses" (1738-'41), which, though written to support an absurd theory, is a monument of erudition, and contains passages of great eloquence. The current philosophy of the 18th century was strongly affected by skeptical tendencies, whose influence pervaded the literature of England as of nearly every European country. Bishop Butler, in the preface of his "Analogy," declared that many persons then took it for granted that Christianity was no longer a subject of inquiry, but had at length been discovered to be fictitious. This spirit of skepticism especially pervaded the department of historical composition, which at this time received a great impulse. Unfriendliness toward Christianity is the chief fault of "The Decline and Fall of the Roman Empire," by Edward Gibbon (1737-'94), one of the greatest historical works in the English language, drawn from a wide variety of sources, and written at once with erudition and genius. The history of England by David Hume, and of Scotland and of the reign of Charles V. by William Robertson, have retained their reputation for ease and elegance, though later researches have shown their neglect of accuracy. Less important historical and biographical writers were Echard, Strype, Smollett, Tytler, Ferguson, Middleton, Watson, Lyttelton, Russell, and Jortin. The principal philosophical and critical works after those of Berkeley and Shaftesbury were Hutcheson's "Inquiry into Beauty and Virtue" and "System of Moral Philosophy," Hume's "Essays" and "Treatise on Human Nature," Adam Smith's "Theory of Moral Sentiments," Reid's "Inquiry into the Human Mind" and "Essays on the Intellectual Powers," Beattie's "Dissertations, Moral and Critical," Hartley's "Observations on Man, his Frame, his Duty, and his Expectations," Price's "Review of the Principal Questions and Difficulties in Morals," Ferguson's "History of Civil Society" and "Institutes of Moral Philosophy," Tucker's "Light of Nature Pursued," Priestley's "Matter and Spirit," Lord Kames's "Essays on the Principles of Morality and Natural Religion" and "Elements of Criticism," Hugh Blair's "Rhetorical Lectures," and George Campbell's "Philosophy of Rhetoric." The critical and controversial writings of Bentley and Atterbury belong to the early part of this period. The theological writers of greatest influence were Clarke, Lowth, Hoadley, Leslie, Whiston, Doddridge, Butler, Warburton, Wesley, Lardner, Farmer, and Leland. Johnson, Goldsmith, and Burke surpassed all others as miscellaneous writers, and probably Johnson exerted by his conversation and his pen a greater influence upon the literature and tone of thought of his age than any other individual. His wit and learning first stemmed the tide of infidelity, and turned the literary current in favor of re-

vealed religion. It was said by Burke that he appears far greater in Boswell's pages than in his own, and the reason is that he conversed with admirable simplicity and plainness, but in his writings adopted an elaborately vicious and ponderous style.—In the 18th century the novel assumed nearly the form and character which have since made it a leading department of literature. The "Arcadia" of Sir Philip Sidney had been followed by a large number of chivalrously heroic and courtly pastoral romances, many of them translations and adaptations, as Johnson's once famous "Seven Champions of Christendom," and in the 17th century the "Man in the Moon" of Francis Goodwin. After the restoration the most popular novels of the continent were translated, but of English original fictions, the "Parthenissa" of Lord Orrery and the tales of Mrs. Behn and Mrs. Manley are all that are now remembered even by the antiquary. Daniel Defoe (1661–1731) first gave to English fiction a simple, direct, matter-of-fact, and human interest, and the verisimilitude of "Robinson Crusoe" has never been excelled. The "Tale of a Tub" and "Gulliver's Travels" by Swift, the "History of John Bull" by Arbuthnot, and his "Memoirs of the Extraordinary Life, Works, and Discoveries of Martinus Scriblerus," are satires in the form of fictitious narratives. The writings of Swift are admirable for their vigor and humor. Under his successors the novel became more complex and artistic, embraced greater varieties of character and diversities of treatment, and pictured the artificial refinements and distinctions of society, the contrasts of temper and manners, and the complicated and conflicting relations of life. The "Joseph Andrews," "Tom Jones," and "Amelia" of Fielding, and the "Pamela," "Clarissa Harlowe," and "Sir Charles Grandison" of Richardson, were published near the middle of the century. Fielding claimed for his great work, "Tom Jones," the dignity of a comic epopee. Its plot, which involves wonderfully diversified characters and adventures, is contrived with almost perfect art, and it portrays the especial features of real life in England, with keenness, coarseness, an easy humor, and a buoyant affluence of practical knowledge. Richardson is one of the most powerful, tragic, and tedious of novelists, and his voluminous works obtained almost unexampled popularity in England and on the continent. He and Fielding were embodiments respectively of the idealistic and the realistic tendency, and each entertained great contempt for the writings of the other. The "Peregrine Pickle," "Humphrey Clinker," and other novels of Smollett are distinguished for coarse, comic incidents and broad humor; and the "Tristram Shandy" and "Sentimental Journey" of Sterne contain masterly touches of character, passages and episodes sparkling with wit and fancy, and also much melodramatic pathos and sentimentality. Three works of fiction contributed es-

pecially to refine the public taste and the style of novels: the "Rasselas" of Johnson, a philosophical essay in the garb of an oriental tale, the "Vicar of Wakefield" of Goldsmith, a picture of English rural life remarkable for kindness and taste, and the "Castle of Otranto" of Horace Walpole, a striking Gothic and chivalric romance. In 1771 Mackenzie produced "The Man of Feeling," and a few years later appeared Miss Burney's "Evelina," a picture of life and manners, which showed that both the vulgar and the fashionable life of London might be delineated with lively skill, and with broad comic humor, without a line to offend a delicate taste. This and her second novel, "Cecilia," are especially esteemed for their characterizations.—With the French revolution begins a new period in English literature. Again, as in the age of Elizabeth, great civil and religious changes were agitated; old habits and feelings were to be set aside, old manners to pass into oblivion; and out of the ruins of venerable institutions political theorists were seeking to rear the structure of a new social order. Amid bloodshed and confusion, in the conflict between traditions and hopes, men were forced to speculate on the very elements of human nature and destiny. The commotion of the times marked a change of scene in the drama of European civilization, and though it did not shake the constitution of England, it stirred the mind of the country in every department, and led to deeper moods of thought and to larger sympathies. The revival of poetry had already been prepared by Cowper. A greater influence, probably, was exerted by Robert Burns (1759–96), whose "Tam o' Shanter," "Hallowe'en," "Cotter's Saturday Night," and numerous songs, were indigenous to the soil of Scotland, and displayed a freshness of humor, pathos, force, and beauty which made them esteemed alike by peasants and scholars, and a union of the morally sublime with the extrinsically humble. Yet his influence did not extend at once to England, where Cowper was still rivalled in popularity by Darwin and Hayley. Connected with these was the Della Cruscan school of affected rhymesters, prominent among whom were Anna Seward, Mrs. Thrale, Mrs. Robinson, Greathead, Merry, Weston, and Parsons, who were ridiculed by Gifford in his "Baviad" and "Meviad." Matthew Gregory Lewis was the originator of a romantic school, both of poetry and prose fiction, abounding in *diablerie* and all manner of extramundane machinery. His verses were reflected in some of the most powerful contemporary prose, and exerted an influence on the early productions of Scott, Southey, and Coleridge, but were demolished by the "Rovers" of Canning and Frere, who also ridiculed Darwin's "Loves of the Plants" by a burlesque entitled "The Loves of the Triangles." William Wordsworth (1770–1850), esteemed by many the greatest poet of his century, devoted his life to poetry. It was the solemn business of

his being, the object of all his thought, observation, reading, and experience. His aim was to renovate and refresh literature by bringing back poetry to truth and nature; and he began by composing lyrical ballads on the humblest subjects in language such as was "really used by men." Readers, long familiar with poems on learned themes or marked by polished sentimentalities, marvelled at his bald topics and colloquial platitudes. Yet his simplicity of feeling, truthfulness of delineation, comprehensive spirit of humanity, and union of deep and subtle thought with sensibility, attracted by degrees a circle of enthusiastic admirers. The works of no other poet have been so exclusively the product of personal experience and retrospection. In striking contrast with Wordsworth was Samuel Taylor Coleridge, whose finest pieces, as "Christabel" and "The Ancient Mariner," were produced early in life, and are unsurpassed as strong, wild, and musical sallies of pure imagination. The faultless rhythm of "Christabel," accentual instead of syllabic, was the acknowledged model of Scott's "Lay of the Last Minstrel." As a philosopher and critic he has inspired many followers to rise to higher standpoints than those of Locke, Paley, and Lord Kames. Robert Southey when a schoolboy conceived the design of exhibiting in narrative poems the grandest forms of mythology that ever obtained among men, and his "Thalaba" and "Curse of Kehama," founded on Arab and Hindoo legends, were the partial fulfillments of his plan, and display through a charming diction extensive learning and brilliant imagination. The irregular, unrhyming verse of "Thalaba" he described as the "Arabesque ornament of an Arabian tale." Southey was the most diligent of literary men, and in almost every department of prose and poetry has left monuments of his talent and erudition. A new tendency appeared in the poems of Sir Walter Scott, who combined the refinements of modern poetry with the spirit and materials of border minstrelsy and of the early metrical romances. He adopted in his principal poems the octosyllabic measure, which had been generally used by the old romancers. From 1805 to 1812, when the first cantos of "Childe Harold" appeared, Scott was the most popular British poet; but he retreated to prose fiction as the genius of Byron began to display its strength. John Wilson, after producing a few poems marked especially by delicacy of sentiment and vigor of description, applied himself chiefly to prose literature, criticism, and philosophy. The celebrity of Lord Byron was unrivalled during his brief and impetuous career; and perhaps no other man, dying at 37, ever wrote so much that was remarkable for intellectual power and intensity of passion. A new phase of the poetic mind appeared in John Keats, who gave great promise before his early death not only by his profusion of beautiful and grand conceptions, but also by the progress which he rapidly made in bringing his genius

under the control of judgment. He had an instinct for choice words, which were in themselves pictures or ideas, and he gave an example of refined sensuousness which has affected especially the forms of poetical expression. He was an early admirer of the poetry of Leigh Hunt, whose manner was derived from Italian models, and his influence appears strongly in the productions of Percy Bysshe Shelley, often most ethereal in imagery and language. Though the conceptions of Shelley were derived from imaginative philosophy and from speculations on elemental nature, rather than from human nature and real life, yet he was instinct with a love and intellectual sense of ideal beauty, which appear in single thoughts and images in his larger productions, and especially in some of his lesser poems, as "The Sensitive Plant," "The Skylark," "The Cloud," and the "Hymn to Intellectual Beauty." His "Prometheus Unbound" is worthy of Æschylus. Thomas Moore, a writer of beautiful songs and of light and elegant satires, displayed his highest powers in the four oriental tales of which "Lalla Rookh" is composed, remarkable for their splendor of diction and copiousness of imagery. George Crabbe produced strong impressions by elaborately chronicling a series of minute circumstances, and in brief passages, as in "Sir Eustace Grey," rises to a fine imaginative energy. Samuel Rogers (1763-1855), the contemporary of a long series of poets, followed no one of the new tendencies, but attained high artistic excellence in the heroic couplet, with a nicety of taste and grace of sentiment worthy of Pope and Goldsmith. Thomas Campbell had a higher genius with an equal culture; and in his lyrical pieces he gave to romantic conceptions a classical elaboration and finish which was hardly attempted by his contemporaries. His "Pleasures of Hope" will always rank as an English classic. Charles Lamb, a peculiar and happily wayward genius, wrote almost nothing that is not exquisite, and his few poems, like his essays, reveal an original wit and genial character, moulded by sympathetic study of the old French writers. His reputation rests chiefly on his "Essays of Elia," the finest of their kind in literature. The poems of Thomas Hood, whether serious or comic, are pregnant with matter for thought. Though a singularly clever rhyming punster and jester, his main strength appears in simple pathetic lyrics like "The Song of the Shirt" and "The Bridge of Sighs;" and even through many of his comic pieces, as "The Last Man," "Miss Kilmansegg with her Golden Leg," and others, runs a deep vein of earnest pathos and tragic power. The Scotch poet James Hogg (the Ettrick Shepherd), with a rare imagination, sometimes excelled marvellously in describing things that transcend nature's laws; and his story of "Kilmeny," a child stolen by the fairies and conveyed to fairy land, is a most charming example of pure poetry. The best compositions of Allan Cunningham are ballads and songs of

a national character, as "The Mermaid of Galway," "She's gone to dwell in Heaven," and "My Nannie, O." William Motherwell was successful both in martial pieces, as "The Sword Chant of Thorstein Raudi" and "The Battle Flag of Sigurd," and in plaintive strains, as the ballad of "Jeanie Morrison." Many of the poems of Walter Savage Landor are attempts to reproduce the genius of ancient Greek poetry, and though they have fine and highly intellectual passages, they seem foreign to England and not akin to modern times. His "Gebir" and "Count Julian," however, contain passages excelled by no other poet. He has a surer reputation for his remarkable prose works, the chief of which is a series of "Imaginary Conversations," than which no better English prose has ever been written. Among the minor poets of this period are Henry Kirke White, Grahame, Bowles, Bloomfield, Hamilton, Lloyd, Lovell, Dyer, Cary, Wolfe, who deserves special mention for his short poem on the "Burial of Sir John Moore," Montgomery, Hartley Coleridge, Heber, Keble, Milman, Croly, Moir, James and Horace Smith, Pollok, Procter, Elliott, Clare, Barton, Sterling, Bailey, Bayley, Moxon, Hervey, Milnes, Swain, Mackay, Aird, Bowring, Præd, Tennant, Herbert, Multrie, Maginn, Anster, Barham, the author of the "Ingoldsby Legends," Trench, A. A. Watts, Aytoun, Tupper, Thomas Davis, Mahoney, Allingham, Barnes, Robert Bulwer Lytton (Owen Meredith), Heraud, Matthew and Edwin Arnold, W. C. Bennett, Alexander Smith, Sydney Dobell, Patmore, De Vere, Horne, Faber, Buchanan, Swinburne, D. G. Rossetti, and Gerald Massey. The most popular English poetess in the first quarter of this century was Mrs. Hemans, among whose numerous productions are some that are melodious in expression and touching in sentiment. The most eminent English poetess of the age, or indeed of any age, was Elizabeth Barrett Browning, who died in 1861. Her longest work, "Aurora Leigh," is a narrative poem, or rather a versified novel, whose characters and incidents illustrate modern English life and manners. A series of love poems called "Sonnets from the Portuguese" convey perhaps the best impression of her graceful, tender, and yet powerful genius. The dramatist Joanna Baillie wrote also ballads and metrical legends. Caroline Bowles (Mrs. Southey) displayed in many of her slight pieces remarkable elevation and simplicity of feeling. Mary Howitt excels in ballad poetry, and in writings marked by innocent mirth and playful fancy, designed for the young. In contrast with her easy simplicity are the elaborate and impassioned poems of Mrs. Norton, who has been called the Byron of modern poetesses. L. E. Landon checked the diffuseness and efflorescent excess of her early productions, which are distinguished at once for vivacity and melancholy, and gave concentration of thought and style to the verses written not long before her mys-

terious death. Her "Ethel Churchill" gives her a place also among novelists. Other poetesses of the time are Mrs. Blackwood, Lady Flora Hastings, Harriet Drury, Camilla Toulmin (Mrs. Crosland), Mrs. Ogilvy, Frances Brown, Christina Rossetti, Jean Ingelow, Mrs. Mulock-Craik, and Eliza Cook. Miss Adelaide Procter, who died in 1864, wrote many lyric poems of singular beauty and refinement. Of living poets, Tennyson, Browning, and Morris are the most eminent.—The most successful dramatic pieces of this epoch have been those of Joanna Baillie, remarkable for their unity of idea and intellectual completeness, the "Bertram" of Maturin, the happily constructed tragedies of Knowles, the "Lady of Lyons" and "Richelieu" of Edward Bulwer Lytton, the "Julian" and "Rienzi" of Miss Mitford, the "Ion" of Talfourd, the "Fazio" of Milman, the comedies of the younger Colman, the plays of Mrs. Inchbald, the "Road to Ruin" of Thomas Holcroft, the "Honeymoon" of John Tobin, and various plays of O'Keefe, Reynolds, Morton, Poole, Planché, Marston, Jerrold, Buckstone, Brooks, Tom Taylor, Boucicault, Gilbert, Holliday, Robertson, and H. J. Byron. The "Remorse" of Coleridge, the "Bride's Tragedy" of Beddoes, the "Tragedy of Galileo" of Samuel Brown, the "Athelwold" of William Smith, the "Philip van Artevelde" of Henry Taylor, the "Legend of Florence" of Leigh Hunt, and the "Strafford," "Blot in the 'Scutcheon," &c., of Robert Browning, are rather dramatic poems than acting plays.—The novel begins with this century to take a foremost place. In the latter part of the 18th century the circulating libraries abounded with the worthless productions of the so-called Minerva press. The works of Charlotte Smith mark the beginning of the transition from the sentimental to the true in popular fictions. A new energy and dignity was given to them by the political tales of Holcroft and Godwin, and especially by Godwin's "Caleb Williams;" and the romantic fictions of Mrs. Radcliffe, the novels of the sisters Porter, of Dr. John Moore, of Mrs. Inchbald, and the "Monk" of Matthew Gregory Lewis, were at least improvements on frippery love plots. The Arabian tale of "Vathek," by William Beckford, was greatly admired for its imaginative power and literary finish, and the "Canterbury Tales" of Sophia and Harriet Lee are remarkable among English fictions for tenderness and feeling. The delineations of character and society by Miss Edgeworth, Mrs. Opie, and Miss Austen preceded the works of Sir Walter Scott, whose example has given to the novel nearly the same importance in contemporary literature which the drama had in the Elizabethan era. His prodigious familiarity with Scotch characters, anecdotes, traditions, and superstitions, the delight which he took in displays of sense, humor, or sentiment, in every strong and original symptom of character, prove how broad a foundation his fictions had in actual life. The popularity of the

novel in the earlier part of our century was shown by the appearance of a crowd of writers of fiction, among whose works may be mentioned the "Self-Control" and "Discipline" of Mrs. Brunton, the "Cottagers of Glenburnie" of Elizabeth Hamilton, the "Hungarian Brothers" of Anna Maria Porter, the once highly popular "Thaddeus of Warsaw" and "Scottish Chiefs" of her sister Jane Porter, the "Cælebs in Search of a Wife" of Hannah More, the "Wild Irish Girl" and the other national tales of Lady Morgan, the "Albigenses," the "Fatal Revenge," and other romantic fictions of Maturin, the "Frankenstein" and "Last Man" of Mrs. Shelley, the "Marriage," "Inheritance," and "Destiny" of Miss Ferrier, the "Annals of the Parish" and "Ayrshire Legatees" of John Galt, the "Salathiel" of George Croly, the "Anastasius" of Hope, the "Valerius" and "Reginald Dalton" of Lockhart, the Scottish tales of Professor Wilson, the eastern romances of Morier and Fraser, the "Sayings and Doings" and other novels of fashion of Theodore Hook, the "Cyril Thornton" of Thomas Hamilton, the Irish stories of Banim, Crofton Croker, Griffin, Carleton, and Mrs. S. C. Hall, the sea stories of Capts. Marryat and Chamier, the "Tom Cringle's Log" and "Cruise of the Midge" of Michael Scott, the "De Vere" of Ward, containing a portraiture of Canning, the "Headlong Hall" and other humorous novels of Peacock, the "Brambletye House" and "Moneyed Man" of Horace Smith, the "Our Village" of Miss Mitford, the "Victims of Society" and other tales of Lady Blessington, the fashionable novels of Mrs. Gore, the musical novels of Miss Sheppard, the "Deerbrook," the "Hour and the Man," and the politico-economical tales of Miss Martineau, the multitudinous novels of G. P. R. James, and the miscellaneous novels of Ainsworth, Hannay, Borrow, Warren, Lever, and Lover, of Mrs. Trollope, Mrs. Bray, Mrs. Gaskell, Mrs. Marsh, Miss Sinclair, Mrs. Mulock-Craik, Julia Kavanagh, and Lady Bulwer. Since the death of Scott the most eminent and popular of English novelists have been Bulwer, Dickens, Thackeray, Disraeli, Charlotte Brontë, and "George Eliot" (Mrs. Lewes). Of these, Disraeli and Mrs. Lewes are still living. Other living novelists of note are Anthony Trollope, Wilkie Collins, Charles Reade, Charles Kingsley, Thomas Hughes, George Macdonald, Justin McCarthy, B. L. Farjeon, William Black, J. S. Le Fanu, Mortimer Collins, Edmund Yates, Charles Gibbon, Mrs. Florence Marryat Church, Mrs. Oliphant, the baroness Tautpœus, Miss Thackeray, Miss Yonge, Miss Braddon, Miss Amelia Edwards, Mrs. Elizabeth Charles, Miss De La Ramé (Ouida), and Miss Rhoda Broughton.—Within this period Mitford, Gillies, Thirlwall, and Grote have produced elaborate general histories of Greece, Finlay has written on the later and Byzantine period of the Greeks, and St. John on the manners and customs of ancient Greece; Sharon Turner, Godwin, Lin-

gard, Palgrave, Mackintosh, Charles Knight, Lord Mahon, Miss Strickland, and Harriet Martineau have produced works on different periods of English history, and Hallam on the constitutional history of England, and on the history of Europe during the middle ages; and various histories have been written by Southey, Tytler, Coxe, Chalmers, Roscoe, Pinkerton, Dunlop, Mill, Mills, Napier, Milman, Crowe, Elphinstone, and Arnold. Carlyle's "French Revolution," "Oliver Cromwell," and "Frederick the Great" are distinguished for research and vigor of character painting. Alison's "History of Europe from 1789 to 1852" gives the English tory view of events with fulness and vigor. Macaulay's "History of England from the Accession of James II." was early interrupted by its author's death, but holds a very high place in historical literature by its brilliant style, vast research, and liberal tone. Buckle's "History of Civilization," another brilliant work, was also left incomplete by the premature death of its author; it made a strong impression by its novel and ingenious theories and heterodox views. Merivale's "History of the Romans" is a work of great learning, and fills satisfactorily the gap between Arnold and Gibbon. Froude's "History of England from the Fall of Wolsey to the Defeat of the Spanish Armada" is a work of original research and occasionally eloquent style, and throws much new light on the character of Henry VIII. and Elizabeth and of Mary queen of Scots. Gladstone's "Studies on Homer and the Homeric Age" and "Juventus Mundi" are able and scholarly, and have at once a historical, critical, political, and religious character. Rawlinson's "Herodotus" and "Ancient Monarchies" are of high value. Useful manuals of history have been written by Rawlinson, Liddell, and William and Philip Smith. E. A. Freeman's "History of the Norman Conquest" and "Essays" on various points of history are original and suggestive. The recent era excels in narratives of travel, of which the most prominent are those of Mungo Park, Denham, Clapperton, Lander, Campbell, Burchardt, Belzoni, Alexander, Buckingham, Porter, Clarke, Mure, Forsyth, Eustace, Hobhouse, Holland, Dodwell, Gell, Beckford, Ross, Parry, Franklin, Beechey, Scoresby, Basil Hall, Inglis, Layard, Fellows, St. John, Fraser, Burnes, Barrow, Harris, Head, Burton, Kinglake, Warburton, Stanley, Atkinson, Oliphant, Trollope, Dilke, Dixon, Sala, Wallace, Baker, Speke, Reade, Palgrave, Cooper, Williamson, Alcock, and Livingstone. In scientific works the present century has been especially rich. The chief writers in its earlier half were Herschel, Brewster, Buckland, Davy, Whewell, Nichol, Prichard, John Pye Smith, and Hugh Miller. Among the most prominent of later days are Owen, Murchison, Lyell, Faraday, W. B. Carpenter, Huxley, Darwin, Mivart, Tyndall, Bastian, Gosse, Lubbock, Tylor, McLennan, Lockyer, Proctor, and Grove. In archæology, the

names of Young, Sharpe, Birch, Goodwin, and Wilkinson on Egyptian subjects, of Rich, Lazard, Sayce, Ilincks, Norris, Rawlinson, and George Smith on Babylonian and Assyrian, have attained distinction. The work of Edward W. Lane on the "Manners and Customs of the Modern Egyptians" is unequalled as a minute and faithful delineation of an oriental people. In the study of Sanskrit and of Indian antiquities the most noted names are Sir William Jones, Colebrooke, Muir, Wheeler, Williams, Cunningham, Fergusson, Caldwell, and Max Müller. The eminent writers on religious subjects were Bishops Horsley, Watson, and Jebb, Joseph Priestley, William Paley, Andrew Fuller, Charles Simeon, Ralph Wardlaw, Thomas Scott, William Wilberforce, Adam Clarke, and Hannah More. The "Tractarian" movement is an interesting department of ecclesiastical literature. Its chief promoters were John Keble, E. B. Pusey, J. H. Newman, and R. H. Froude. Very different phases of belief appeared at about the same time in the writings of Isaac Taylor, Henry Rogers, James Martineau, and William Cureton, while the views of English Roman Catholics were expressed by Cardinal Wiseman, Archbishop Manning, F. W. Faber, and Kenelm Henry Digby. The most remarkable sermons have been those of Alison, Irving, Robert Hall, Chalmers, Robertson, and Spurgeon. The more distinguished writers upon the Bible are Kitto, Trench, Alford, Conybeare, Howson, Ellicott, Colenso, Westcott, Davidson, Henderson, Fairbairn, and J. G. Murphy. Other religious writers of importance are Peter Bayne, Tregelles, R. and C. J. Vaughan, Tulloch, Seeley, Maurice, and Robertson. In biographical works this period is peculiarly rich. The most popular and important of these are the lives of Nelson and Wesley by Southey; of Sheridan and Byron by Moore; of Petrarch and Mrs. Siddons by Campbell; of Burke and Goldsmith by Prior; of Goldsmith, Landor, Dickens, and the statesmen of the commonwealth by Forster; of Napoleon and the English novelists by Scott; of British painters, sculptors, and architects by Allen Cunningham; of the statesmen and men of letters and science of the reign of George III. by Brougham; of the chancellors and chief justices of England by Lord Campbell; of British military commanders by Gleig; of eminent statesmen and great commanders by James; of eminent Scotsmen by Chambers; of Condé by Mahon; of Howard, Blake, Penn, and Bacon by Hephworth Dixon; of Napoleon by Hazlitt; of Sir Walter Scott by Lockhart; of Charles Lamb by Talfourd; of Newton by Sir David Brewster; of Campbell by Beattie; of Mackintosh by his son; of Horner by his brother; of Sydney Smith by his daughter; of Charlotte Brontë by Mrs. Gaskell; of Dr. Arnold by Stanley; of Goethe by Lewes; of Moore by Earl Russell; of Chatterton by Wilson; of Pope by Elwin; of Edward Irving by Mrs. Oliphant; of Sir Joshua Reynolds by

Taylor; of George and Robert Stephenson by Smiles; and lastly we may mention the monographs of John Morley on Burke, Voltaire, and Rousseau, and the autobiographies of Lord Brougham, of Sir Henry Holland, and of Henry Crabb Robinson, and the "Memorials of a Quiet Life" by A. J. C. Hare. Among miscellaneous writers on literature, Isaac Disraeli, Sir Egerton Brydges, and John Foster became prominent near the beginning of the century. The number of books has often been increased by miscellaneous collections from the reviews, journals, and magazines, as the "Noctes Ambrosianæ," from "Blackwood's Magazine," chiefly by Prof. Wilson; the "Essays" of Jeffrey and Sydney Smith, Macaulay and Carlyle, from the "Edinburgh Review;" the witty productions of Douglas Jerrold, collected from "Punch;" and many of the writings of Hazlitt and De Quincey. Cobbett and J. Wilson Croker acquired distinction as political pamphleteers, and the latter also by his vigorous and pungent articles in the "Quarterly Review." Frances Power Cobbe has attained a high reputation by her "Essays" and other writings on a variety of subjects. Among the notable works of the day may be mentioned Morell's "History of Philosophy," Lecky's "History of Morals" and of "Rationalism," Maine's "Ancient Law," the duke of Argyll's "Reign of Law," Greg's "Enigmas of Life," and Baring-Gould's "Myths of the Middle Ages," "Origin and Development of Religious Belief," and "Legends of the Patriarchs and Prophets." Important contributions have been made to English art literature by Lindsay, Eastlake, Leslie, Hazlitt, and especially by Mrs. Jameson, Ruskin, Tyrwhitt, and Hamerton. The principal metaphysical writers of the Scottish school were Thomas Reid, Dugald Stewart, Dr. Thomas Brown, and Sir William Hamilton. The more peculiar tendencies of the English mind appeared in Paley. Bentham wrote important works on jurisprudence; Archbishop Whately on logic, political economy, and theology; J. Stuart Mill on logic, on liberty, and on political economy; and Herbert Spencer has written voluminously on psychology, biology, social statics, and similar subjects.—The best historical and critical works on the literature of England are: Wright's "Biographia Britannica Literaria" (vol. i., the Anglo-Saxon period, 1842; vol. ii., the Anglo-Norman period, 1846); Warton's "History of English Poetry," extending to near the end of Queen Elizabeth's reign (3 vols., 1774-'81); Hallam's "Introduction to the Literature of Europe in the 15th, 16th, and 17th Centuries" (1837-'9, with additional notes in later editions); Collier's "History of English Dramatic Poetry" (1831); Chambers's "Cyclopaedia of English Literature" (2 vols., 1843-'4); Lowndes's "Bibliographer's Manual" (new ed. by Bohn, 6 vols., London, 1857-'64); Allibone's "Critical Dictionary of English Literature" (3 vols., Philadelphia, 1858-'73); Craik's "History of



the English Literature and Language" (London, 1861); Morley's "English Writers" (London, 1864-7) and "First Sketch of English Literature" (1873); Skeat's "Specimens of English Literature from 1394 to 1579" (Oxford, 1871). Among brief manuals are Shaw's "Authors of English Literature" (London, 1848); Spalding's "History of English Literature" (New York, 1853); T. Arnold's "Manual of English Literature" (London, 1869); Day's "Introduction to the Study of English Literature" (New York, 1869); Minto's "Manual of English Prose Literature" (Edinburgh and London, 1872); and Hart's "Manual of English Literature" (Philadelphia, 1872). In 1864 appeared Taine's *Histoire de la littérature anglaise* (5 vols., Paris), exhibiting a comprehensive grasp and keen analysis especially remarkable as the work of a foreigner. It was translated by H. Van Laun and published in Edinburgh and republished in New York in 1871 (2 vols. 8vo).

**ENGLAND, John**, first Roman Catholic bishop of Charleston, S. C., born in Cork, Ireland, Sept. 23, 1786, died in Charleston, April 11, 1842. He entered the college of Carlow in 1803, and while there founded a female penitentiary and poor-schools for both sexes. He was ordained priest Oct. 9, 1808, and appointed lecturer at the North chapel in Cork, and chaplain of the prisons. In the following May he commenced the publication of a monthly magazine called the "Religious Repertory." In 1812 he became president of the theological college of St. Mary, in which he also lectured on divinity. About the same time he exerted himself to put down bribery at elections, and in the "Repertory" attacked the existing system of criminal jurisprudence, and opposed the purchasing of Catholic emancipation by concessions to the English government. His boldness brought him before the courts, and on one occasion he was fined £500. He founded several religious and charitable institutions in Cork, and in 1817 was made parish priest of Brandon. In 1820 he was appointed bishop of the new diocese of Charleston, S. C., comprising the states of North and South Carolina and Georgia, with a scattered Catholic population of about 8,000, and only four priests, and arrived there in December. Here he established an academy and a theological seminary, in both of which he taught, supporting the latter institution by the revenue from the former. He founded an anti-duelling association, visited every part of his diocese, had special services in the cathedral for the negroes, and established the "Charleston Catholic Miscellany," the first Roman Catholic paper published in America. In 1826 he preached before the senate at Washington. In 1832 he spent some time in Rome, when the pope appointed him apostolic legate to Hayti. He visited that island twice, and made voyages to Europe in 1833, 1836, and 1841. His learning, ability, and high moral character, and above

all his heroism during a season of yellow fever, gave him a high standing in Charleston; and the spectacle was sometimes witnessed of the Catholic bishop preaching on Sunday in a Protestant church to a Protestant congregation. He left many writings, most of which appeared in the periodical press. A complete edition of his works was prepared by Bishop Reynolds (5 vols. 8vo, Baltimore, 1849).

**ENGLISH, George Bethune**, an American author and adventurer, born in Cambridge, Mass., March 7, 1787, died in Washington, D. C., Sept. 20, 1828. He graduated at Harvard college in 1807, and was admitted to the bar in Boston, but subsequently studied divinity at Cambridge. In 1813 he published "The Grounds of Christianity Examined," a work in favor of Judaism, which was answered by Edward Everett, and by S. Cary. English subsequently edited a western newspaper, and sailed to the Mediterranean as a lieutenant of marines, but resigned his commission, and is said to have professed Mohammedanism. He accepted a commission in the army of Ismail Pasha in 1820, and served as an officer of artillery in an expedition against Sennaar. He afterward became an agent of the American government in the Levant, returned to America in 1827, and took up his residence in Washington. He wrote replies to Mr. Everett and Mr. Cary; a letter to W. E. Channing regarding his two sermons on infidelity (1813); and a "Narrative of the Expedition to Dongola and Sennaar" (London, 1822; Boston, 1823).

**ENGLISH, Thomas Dunn**, an American author, born in Philadelphia, June 29, 1819. He received the degree of M. D. from the university of Pennsylvania in 1839, and was called to the bar in 1842. He has been connected with journals in New York and elsewhere, edited magazines, and taken part at various times in politics. He is the author of several novels, mostly pseudonymous, and more than 20 successful dramas. Only three of the novels were acknowledged: "Walter Woolfe" (1844), "MDCCCXLIV., or the Power of the S. F.," a political exposé, and "Ambrose Fecit" (1867); and of the dramas only one, "The Mormons," which has been printed and is still occasionally represented. Dr. English is best known by his "Ben Bolt," a popular song, which appeared in the New York "Mirror" in 1842, and his "Gallows-Goers," a rough but vigorous poem, of which hundreds of thousands of copies were circulated during the agitation of the question of capital punishment from 1845 to 1850. He printed a collection of his poems in New York in 1855, but suppressed its publication. In 1856 he established his residence in New Jersey, near New York, where he has since practised as a physician. He has represented his district in the New Jersey legislature. Of late years his literary work has been confined mainly to a series of poems illustrating the revolutionary history

and local dialects of the United States, which have appeared in magazines.

**ENGLISH CHANNEL**, an arm of the ocean, separating England from France, extending on the English side from Dover to the Land's End, and on the side of France from Calais to the island of Ushant. At the W. end it is 100 m. wide; on the east, where it is united to the North sea by the strait of Dover, it is 21 m. across, and its greatest width is about 150 m. The English coast of the channel is 390, and the French 570 m. in length. In it are the isle of Wight, Guernsey, Jersey, and other islands. A current appears to run through it from the west. On the English coast it has some excellent harbors, but those on the French side, excepting the artificial port of Cherbourg, are too shallow for men-of-war. Important pilchard, mackerel, and oyster fisheries are prosecuted in its waters. From its shape the French call it *la Manche*, "the sleeve."

**ENGRAFTING.** See GRAFTING.

**ENGRAVING**, the art of producing designs, either by incision or by corrosion, on the smooth surface of a wooden block, metallic plate, or other substance, for the purpose of transferring them to paper. In this sense the art is comparatively modern, being but little older than that of printing, but in a more restricted sense it has been practised from a remote antiquity. Engraving on metallic plates is mentioned in Exodus xxviii. 36, and numerous other passages attest that the Israelites were skilful in it, and also in gem and seal engraving. They acquired the art undoubtedly from the Egyptians, who, as well as the Assyrians, engraved both on stone and metal. Specimens of incised copper plates found in mummy cases show that they were executed with tools similar to those now in use, and impressions taken from them at the present day prove that the Egyptians needed but a single step to make the discovery of engraving in its modern sense; but the idea of filling the incisions with color and taking a print from them on paper seems never to have occurred to them. The Assyrians even went so far as to take impressions from their engraved slabs in clay; and wax and other plastic substances were used for a similar purpose. Herodotus, speaking of a period 500 years before Christ, mentions a tablet of brass on which was a map of "every part of the habitable world, the seas, and the rivers." In India and in China the art was practised from the most remote ages. Indeed, the various processes of metallic engraving, die sinking, and gem cutting prevailed among every ancient people who had made any progress in civilization. In its more modern sense, engraving was probably first practised on wood, but its origin is involved in obscurity. The Chinese assert that they printed from engraved wooden blocks more than 1,000 years before Christ; but as they were unacquainted with the art of making paper until about A. D. 100, their assumption may be doubted. It is gen-

erally conceded, however, that they practised the art at an early period, and it is supposed that it was introduced from China into Europe through the intercourse of Venetian merchants. Marco Polo describes the making of paper money in China by stamping it with a seal covered with vermilion. This was about the close of the 13th century, but even this simple art was not practised, so far as is known, in Europe until about a century later. Playing cards and rude cuts for devotional manuals were printed from engraved blocks in Italy, and perhaps in Germany, as early as the year 1400, if not earlier. A decree of the magistracy of Venice, dated Oct. 11, 1441, forbids the importation of any work printed or painted on cloth or paper, because the mystery of making playing cards and printed figures had fallen into decay on account of the influx of foreign manufactures. The "St. Christopher" of 1423, a woodcut of folio size, in the collection of Earl Spencer, was supposed for a long time to be the most ancient example of engraving known; but the baron von Reiffenberg recently discovered one of 1418, and M. Henri Delaborde found two plates printed on the leaves of an old manuscript which prove the existence of wood engraving and the use of the printing press in 1406 (*Gazette des Beaux-Arts*, March, 1869). Among the earliest specimens of illustrated books that have come down to us is the so-called *Biblia Pauperum*, supposed to have been produced between 1430 and 1450. It is a small folio of 40 leaves, each containing a picture, with a text of Scripture or other explanatory sentence below it. The *Speculum Humanae Salvationis*, another noted example of block-book printing, dating from about 1470, consists of 63 leaves of the same folio size, containing 58 pictures, with two lines of Latin rhyme under each. The legends on these early pictures led to the invention of printing. Many works printed in Italy, Germany, and England during the latter part of the 15th century were adorned with cuts, but they were generally of the rudest kind, with broad heavy lines. Near the beginning of the 16th century "cross hatching," as the lines of shadow crossing each other are technically called, was first practised. It was freely used in the Nuremberg chronicle in 1493. The art made rapid progress, and early in the 16th century reached a high degree of excellence. The engravers invented about this time a way of joining the blocks together so that plates of very large size were made. One representing the triumphal arch in honor of the emperor Maximilian I. measured 10 by 9 ft. About 1610 wood engraving began to decline, and at length was applied only to tapestry and calico printing. The art was revived in recent times, the chief impulse being given to it by the founding in England of the "Penny Magazine" about 1833. This work was to contain many illustrations, and to be published cheaply and at short intervals, which made it necessary to print the pictures with the letterpress. This

could be done with wood engravings only, and great pains were taken to make improvements in the art. Since then it has made rapid advances, and has resumed the place in book illustration from which plate engraving for a time deposed it.—German scholars long regarded Martin Schön or Schongauer as the inventor of plate engraving, quoting some impressions executed, according to them, about 1460; but the abbé Zani found in Paris a proof of a pax representing the coronation of the Virgin, dated 1452, the original plate of which, by Maso Finiguerra, is still preserved in Florence. This would seem to corroborate Vasari's assertion that the first use of a metal plate for engraving was by Finiguerra, a goldsmith of Florence, who practised the decoration of gold and silver plate with *niello* work, a process consisting of running into lines cut in the metal a black alloy of silver, lead, copper, sulphur, and borax. The surface, when scraped down and polished, appeared beautifully ornamented according to the skill and taste exhibited in the pattern. To obtain a copy of the engraved figure before filling it, Finiguerra is said to have applied soot and oil and taken an impression on damp paper; and thus was made the first print on paper from a metallic plate. But Passavant, in the *Archives de Naumann* (1858, p. 1), describes an engraving of the Virgin bearing the date of 1451; and Renouvier in a recent pamphlet reveals the existence of a series of prints of the "Passion" made in 1446. The earliest works were executed on tin, zinc, or iron; but copper soon became recognized as the metal best adapted for engraving, and until the invention of steel engraving it was used almost to the exclusion of other metals. The art spread quickly over Europe. Painters of distinction, as Botticelli, Andrea Mantegna, Giovanni Bellini, Campagnola, and others, gave their attention to it, and it was rapidly perfected. This was especially the case in Germany and the Netherlands, where it was adopted by many eminent men, among whom Albert Dürer is particularly distinguished. Rembrandt, Vandyke, and other great painters also executed valuable works with the etching needle, and Raphael highly prized the services of the great Italian engraver Marc Antonio, who transferred to copper many of his designs. The art was introduced into England at an early period, an illustrated work called the "Golden Legend" having appeared in 1483, and in 1543 Vesalius's work on anatomy, in Latin, illustrated with copperplate engravings. Maps of English counties were engraved in 1579, but little progress was made previous to the 18th century, when Vertue and Hogarth, and subsequently Strange, Woollett, Bartolozzi, Sharp, and others, brought the art to a high degree of excellence. Italy is no longer pretentious for her engravers; but within the century she has furnished some of transcendent merit, whose works will compare with the best of their predecessors. At the head of these stands Raphael Morghen (died 1838),

whose "Last Supper" after Da Vinci, and "Transfiguration" and *Madonna della Seggiola* after Raphael, are among the most costly productions of the art. Schiavoni, the Anderlonis, Bettelini, Longhi, Porporati, Pavon (a pupil of Raphael Morghen), and others, have engraved with success many of the works of the old masters. Toschi (died 1854) took high rank among line engravers by his print of the "Entry of Henry IV. into Paris," after the picture by Gérard, as well as by his "Descent from the Cross," after Volterra, *Spasimo di Sicilia*, after Raphael, and other works from the old masters. Rosaspina, Bisi, Mercuri, and others, have produced many meritorious prints from masters both old and modern. In Germany the art has witnessed a steady improvement since the beginning of the century. Rahl, Hess, Reindel, Umer, Leybold, Kessler, Kobell, Barth, Klein, J. H. and J. J. Lips, Steinla, and others, have gained eminence as line engravers; and Christian Friedrich von Müller, who died in 1816, aged 33, produced a print from Raphael's *Madonna di San Sisto*, which is regarded as one of the noblest achievements of the graver. His father, J. G. von Müller, was also a good engraver, and among other works executed the well known print of the battle of Bunker Hill from Trumbull's picture. The *renaissance* in German painting, effected by the efforts of Cornelius, Overbeck, Schadow, Kaulbach, and others, has had a marked influence on the art of engraving, and within the last half century has arisen a school of engravers who have coöperated with these masters in their endeavors to restore to art its ancient simplicity and deep religious feeling. Prominent among these are Ruscheweyh, who was associated, at Rome with Cornelius and Overbeck, and who has engraved the chief works of the new school; Amsler, Keller, the Felsing, and Merz, who have drawn their inspiration from the same source; Thäter, Eichens, Mandel, Rahn, and Schleich, who, among other works, have engraved some of the masterpieces of Kaulbach, Schnorr, Scheffer, &c. In France as in Germany the efforts of engravers are now less directed to the reproduction of the works of the old masters, or of indifferent designs for illustrated books, than to the execution of prints after contemporaneous painters. David, Gros, Ingres, and others, have afforded numerous subjects; and of such popular painters as Vernet, Delaroche, and Ary Scheffer, nearly every important work has been engraved. Yet France has produced some excellent line engravers after the old masters, among whom may be mentioned the baron Desnoyers (died 1857), who executed fine prints of Raphael's *Belle jardinière* and "Transfiguration," and of Gérard's Napoleon; Prévost (died 1861), who engraved Paul Veronese's "Marriage of Cana;" the Massards, Lecomte, Lorichon, Bein, Richomme, Forster, Martinet, Lignon, Gudin, Audouin, Bridoux, Girard, &c. Of those who have

devoted themselves to the works of modern masters, the most eminent perhaps is Henriquel-Dupont, whose line engraving of Delaroché's fresco in the hemicycle of the *palais des beaux-arts* is unsurpassed in merit or dimensions by any recent work of the kind. Blanchard, Prudhomme, Louis, and the brothers François, have engraved many of the works of Vernet, Delaroché, and Scheffer, and C. R. J. François has confined himself exclusively to Delaroché's works. Girardet (died 1865) engraved from these masters, and also several subjects from American history, including Leutze's "Washington Crossing the Delaware," Stuart's portrait of Washington, &c. Jazot is celebrated for his aquatints from the battle pieces of Gros and Vernet, and Calamatta (died 1869) executed admirable portrait prints of Lamennais, Guizot, Fourier, and Madame Dudevant. Calame, a Swiss artist (died 1864), produced many admirable etchings. The practice of copying the old masters, and to a considerable extent of line engraving, has fallen into disuse in England, the latter being employed principally in large landscapes or in the higher class of figure pieces. Here again, as in Germany and France, the works of a few eminent native artists have occupied the attention of the chief engravers almost exclusively, and under the influence of painters like Reynolds, Lawrence, Wilkie, Turner, and Landseer, the art has been prosecuted with great success. Raimbach, Stewart, Burnet, Smith, and others, have made Wilkie's pictures generally known through the medium of excellent line engravings; and Goddall, Willmore, Pye, Wilson, Prior, Finden, Wallis, and Cousen have done the same for the landscapes of Turner, Stanfield, Constable, Callcott, Roberts, and the other great English masters of this department of painting. Martin's mezzotints of the "Fall of Babylon," "Belshazzar's Feast," &c., after his own designs, are striking works and well known. The engraving of Sir Edwin Landseer's works, of which nearly 200 different prints have appeared, has employed a numerous band of engravers, prominent among whom are the artist's brother Thomas Landseer, Cousins, Lucas, Bromley, Ryall, Atkinson, Baker, Wass, Gibbon, Graves, Bacon, and Robinson. Doo, Watt, Heath, Hollaway, who engraved the cartoons of Raphael in Hampton court, and others, have produced good line engravings from the old masters; and the more modern English painters, such as Leslie, Newton, Eastlake, Etty, Ward, Webster, Maclise, Millais, Frank Stone, Herring, and T. Faed, have found ready interpreters in Richardson, Bellin, Sadd, Howison, Walker, Simmons, Stocks, Reynolds, J. Faed, Hall, and many others. The etchings of George Cruikshank from his own designs are also of the highest order of merit. Wood engraving in Europe, and particularly in England, has reached a perfection unknown to any previous era in the history of art; and in the

latter country the woodcuts of the Dalziel brothers, Evans, Cooper, Palmer, Linton, and others, have a richness and delicacy of finish not inferior to the highest efforts of the engravers on metal. In the Netherlands the principal engravers are Vinckles and Van Genus, Van Trostwyck, Van Os, Overbeck, Janson, Chalon, Claessens, De Frey, and Corr. In the United States the most eminent names are Durand, Cheney, Smillie, Danforth, Dick, Halpin, Marshall, and Andrews.—According to the material used for receiving the designs, the art is designated as xylography, chalcography, siderography, and lithography—from *ξύλον*, wood, *χαλκός*, copper, *σίδηρος*, steel, and *λίθος*, stone. The last will be treated under its own designation. Engraving proper may be considered under two heads: wood engraving, where the print is made from a surface, and plate engraving, where the impression is made from lines cut into the metal or other substance on which the engraving is made. I. XYLOGRAPHY, or WOOD ENGRAVING, is the earliest, simplest, and cheapest form. Various woods are used, boxwood exclusively for fine work, and mahogany, maple, and pine, and occasionally pear, apple, and beech, for coarse work. The old engravers cut on large blocks of soft wood, such as pear tree, the way of the grain; those of the present day use small blocks of hard wood, and cut across the grain. Some soft woods, such as pine, used for engraving placards and posters, are still cut with the grain. In preparing boxwood blocks, the log is sawn into transverse slices, "type high" (about  $\frac{1}{8}$  of an inch), so that the face of the engraving will be even with the type when in the form. After thorough drying, to prevent warping and cracking, it is trimmed square. If the cut is large, a number of these blocks are put into the hands of different engravers, each of whom executes a part, and the various pieces are then fitted together and securely clamped. In this manner a very large engraving can be produced in a short time. The face of the block having been made smooth and free from inequalities, the artist covers it with a light coat of flake white mixed with gum water. This makes a ground for the drawing, and retains pencil marks or India ink. Drawings may be made with a lead pencil, pen, brush, or with brush and lead pencil combined. The drawings of the time of Albert Dürer are supposed to have been made with pen and ink. Modern drawings, not being fixed, are liable to be obliterated by the engraver, and are usually covered with paper, a small piece being torn away from the part on which he is engaged. Drawings made with the lead pencil and the pen require more mechanical than artistic skill in the engraver; those with the brush, or brush and pencil combined, the reverse. The work of the wood engraver is precisely the opposite of that of the plate engraver. The latter cuts the lines of the drawing into the metal; the former cuts

away the surface around the lines, leaving them in relief. There is a method of wood engraving in which the lines are cut in the block as in plate engraving. It differs from the latter in that the ground receives the ink instead of the lines, which thus appear white on the paper.

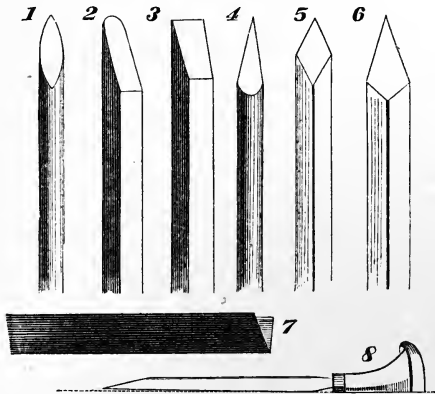

Fig. 1.—Tools for Wood Engraving. 1. Elliptic. 2. Gouge. 3. Chisel. 4. Tint. 5. Lozenge. 6. Graver. 7. Tool for Pine. 8. Tool in Handle.

Modern engravers use a greater variety of tools than were known in the early stages of the art. The old engravers had only small knives and gouges; now the artist has gravers of different widths to cut out the spaces between fine lines, and broader chisels and gouges to remove wide spaces. Fig. 1 shows the different tools used. Parallel lines, used largely in wood engraving where a flat even appearance is desired, are made by the ruling machine, which produces effects in relief printing similar to those of the ruling machine in plate engraving. (See fig. 2.)

II. PLATE ENGRAVING. Engraving on metal plates may be classed under the following heads: etching, line, stipple or chalk, mezzo-

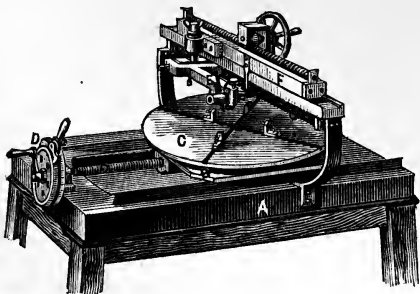

Fig. 2.—Ruling Machine. A. Foundation. B. Bed Plate. C. Revolving Plate. D. Feed Wheel and Screw. E. Tool. F. Carriage. G. Wave Roll.

tint, and aquatint. The instruments used are the same, with some modifications, in all the styles. The etching needle or point is a piece of stout steel wire inserted in a handle and ground to a fine point on a hone. Two or three needles, of different thicknesses, are used,

some for broad and some for fine lines. The dry point is a similar instrument, but with a more delicate point, used for making outlines to be filled up afterward by the burin or graver. The latter, the principal tool of the engraver, is a small instrument of tempered

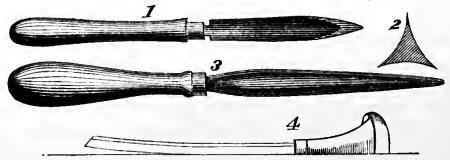

Fig. 3.—Steel Engraver's Tools. 1. Scraper. 2. End View of Scraper. 3. Burnisher. 4. Burin.

steel, with one end ground off obliquely so as to produce a sharp cutting point, and the other inserted in a handle. Several are required, the ends of which differ in form from a lozenge to a square, the former for cutting fine, the latter broad lines. The angle at the meeting of the two lower sides is called the belly, and the breadth of the end the face. The scraper is an instrument used for taking off the burr raised on the metal by the cutting tools. The burnisher is employed to soften lines bitten in or engraved too deep, or to polish the plate when scratched. —Etching may be classed under two heads, painters' etching and engravers' etching. The former is a method of engraving which was practised by many of the old painters, and which has recently come into fashion among artists. The process is nearly the same in both cases. In painters' etching a copper plate is used, which is covered with a film composed of asphaltum and wax, technically called the etching ground. This ground is blackened with lampblack mixed with the varnish. The engraver then makes his drawing with etching needles, cutting through the ground to the plate, making his lines fine or broad according to the depth required, working as he would with a pen or pencil. A border or bank of wax is then raised around the plate, and diluted nitric acid is poured over it. The etching ground resists the action of the acid, which corrodes only the parts uncovered by the needles. When the work is well bitten in, which will be in about a quarter of an hour, the acid is poured off and the plate cleaned, when a proof is taken. If the lines of the lighter parts appear to be sufficiently etched, they are painted over with some of the asphaltum ground dissolved in spirits of turpentine or with sealing wax dissolved in alcohol, and the acid is reapplied to the other parts. This covering of a portion of the plate is called stopping out, and the process of stopping out and biting in is continued until the required depths of line are all attained. Three bitings in are generally enough for a painter's etching. Lines too strongly bitten are rubbed up with the burnisher. Various modifications of this process have been used. Other pro-

cesses also are in use, for which certain advantages are claimed. That invented by P. G. Hamerton in 1871, and named by him the "positive process," is much practised. The plate is brightened first with cyanide of silver, on which is laid a ground of white wax dissolved in ether, the effect of the ether being to purify the wax. After drying for three days, a second coat of wax is applied, and the back and edges of the plate are painted with Japan varnish. When ready for use, the plate is placed in a shallow bath, into which it is fastened by balls of wax pressed into the corners. The mordant, composed of chlorate of potash 20 grammes, hydrochloric acid 100, and water 880, is then poured over the plate so as to cover it completely, when it is ready for the artist, who sketches with the usual needles or with strong sewing needles fastened in a handle. If the bath is in proper condition, the line will blacken as soon as it is drawn. If a second or a third biting in becomes necessary, the plate must be cleaned, resilvered, and coated with fresh wax. The advantages of the positive process are that the artist sees his work in black on a white ground, as in drawing with a pencil on paper, and the lines never glisten as in the old method. The invention of etching is generally attributed to Albert Dürer, but it is probable that it was practised before his time. Rembrandt is the representative etcher, and some of his works command very high prices. One known as the hundred-guilder print has been sold for £1,180. Rembrandt founded the Dutch school. Among his followers, Ostade produced some fine works, and the etchings of Bega, though wanting in delicacy, are prized for the spirit and life of the figures. The landscapes and cattle pieces of Nicholas Berghem and the animals of Paul Potter are celebrated. Vandyke's etchings are as noted as his paintings. Of the French school, Jacques Callot, Charles Méryon, Lalanne, Jules Jacquemart, Charles François Daubigny, Applan, and Jongkind have produced remarkable works. Among English etchers of note are Turner, David Roberts, Wilkie, Geddes, Ruskin, Landseer, Cruikshank, Doyle, Whistler, Samuel Palmer, and Hamerton. Germany is not particularly noted for etchers, and in Italy Canaletti alone is prominent. A number of American artists have practised etching within the past few years, but they have confined themselves generally to humorous subjects. The best treatises on the subject are that by Lalanne (Paris, 1865), and P. G. Hamerton's "Etchers and Etching" (London, 1868). Etching is employed largely for producing ornamental designs on glass. The method is the same as in etching on copper, but the acid used is hydrofluoric, generated in a leaden vessel over which the prepared glass is placed.—Engravers' etching is engraving executed with the tracing point instead of the burin, and bitten in with acid. A portion of every composite steel engraving is etched.

An engraver's etching differs from a painter's in that it is unfinished, the work being only initiatory to that of the burin. Engravers of historical and other subjects, including figures, etch little more than the outlines and the broad masses of the draperies; but landscapes, skies, architectural work, and animals are generally produced in this way. In map engraving, the sinuous lines indicating coasts and the banks of rivers, the marks denoting swamps, and the outlines of mountains are etched. Roads, canals, the waters of lakes and rivers, groups of houses, &c., are put in with the burin. Lines which can be ruled are made with the dry point, and cities, towns, and villages, represented by various kinds of circles, are engraved with an instrument peculiar to map makers.—Line engraving is the art of rendering or translating forms, materials, and colors or effects of a picture into black and white through the medium of lines engraved or sunken in the surface of metal plates or other materials, from which impressions may be printed. Forms are rendered by the directions and courses of the lines, effects and color by the depth and width of the lines and their distances from each other, and materials or surfaces by the quality of the lines. The highest grade of line engraving is executed with the burin or graver directly on the metal, and is limited to reproductions of the human figure. Delicate lines are put in with the dry point. This does not cut clean, like the burin, but leaves a burr which is removed with the scraper. Parallel lines required in series, such as those in flat tints in skies or in buildings, are cut with the ruling machine, which produces more even tints than hand work, but at the expense of freedom. The lines too, unless very skillfully ruled, wear quicker and become clogged with ink sooner than those made with the graver.—Stipple engraving is executed in dots instead of lines, and is practised commonly in connection with etching. The plate is covered with the etching ground, and the subject is transferred to it in the usual way. The outline is then laid in with small dots with the graver, and the darker parts are etched in larger dots laid closely together. The ground is next removed and the work finished with the graver. For producing great delicacy in shading, a fine dry point is used. Stipple engraving was much practised by the English in the latter part of the last century. It is combined frequently with line engraving on the same plate. It is well adapted to give a soft pleasing effect in shading the human figure, and is employed therefore in portraiture and in engravings of sculpture. It is sometimes called chalk engraving, because used to imitate drawings in chalk. In this case the dots are made with less regularity and uniformity in size. Sometimes the dots are struck in with a hammer, when the work is called *opus mallei*, but this is little practised. Stipple engraving dates from the end of the 17th century, and

Morin and Boulanger are considered as the inventors. In 1740 François invented an instrument called a roulette, a small steel wheel with a toothed edge, which being rolled over the plate produced dotted lines. This was used chiefly in chalk engraving.—Mezzotint engraving differs from other styles both in execution and in the appearance of the impressions given by the plate. A mezzotint engraving resembles a drawing washed in with the brush, rather than a work executed with a steel instrument. The operation is the opposite of that in other methods. In ordinary engraving the process is from light to dark, in mezzotint from dark to light. The plate is prepared by running over it a toothed instrument called a cradle, which raises a burr all over its surface. This is called laying the ground. A print taken from the plate at this stage would be uniformly black, while an ordinary plate previous to engraving would give no impression. The plate being thus prepared, the lights and shades of the engraving are produced by rubbing away with scrapers and burnishers the parts where lights are desired, and by increasing the indentations for deeper shades. An agreeable softness is produced by the harmonious gradations of the tints more easily than by other methods. By etching the outlines before laying the ground, a more decided character is given to the print. A pure mezzotint engraving is seldom produced, the process being combined usually with line and stipple. Mezzotint plates are now prepared by a machine invented by Saulnier for ruling lines. This style of engraving is supposed to owe its origin to Ludwig von Siegen, an officer in the army of the landgrave of Hesse, whose first work was published about 1640. It was introduced into England by Prince Rupert, and several prints executed by him are still in existence.—Aquatint engraving is so called from the similarity of its effect to a drawing in India ink or bistre. After the design has been etched in outline, and the etching ground removed, a solution of resin or of Burgundy pitch in alcohol is poured over the plate as it lies in an inclined position. As the alcohol evaporates, the resinous matter is left in granulations over the surface. The design is then drawn with a gummy sirup called the bursting ground, which is applied wherever a shade is to be produced. The lights are left untouched. The whole is next covered with a coating of turpentine varnish, and a border of wax is raised around the plate. Water is poured upon it and left for 15 minutes, when the bursting ground cracks open, exposing the copper. It is then ready for the nitric acid, which is used as in etching, and may be applied several times after each stopping out of the portions sufficiently corroded to produce the desired shades. The bursting ground is not always required, the acid being applied directly upon the granulations, which protect the parts they cover, and the varying shades are produced

by repeated corrosions and as many stoppings out. Some artists dust certain resinous powders on the plate instead of obtaining the granulations by the alcoholic solution. Gum sandarac is used for this purpose, or the purest resin pulverized, and sifted through muslin upon the plate, to which the particles attach themselves on its being heated. Colors are sometimes applied to the plates, and the design is at once printed in its intended colors; but where several colors are employed in contact with each other, it has been customary to use as many different plates, one for each color, and print in succession, the plates being kept in their exact places by fitting upon four fixed pins that pass through holes in their corners. This method was formerly practised in printing cotton cloth. Aquatint has been superseded by lithography and chromo-lithography, and is now but little used. The process is a French invention, and originated with J. B. Leprince about 1787. It was perfected by English artists, who executed works of great merit by this method.—Copper was used almost entirely for plate engraving until the present century, when the discovery by Jacob Perkins, of Newburyport, Mass., of a process for decarbonizing steel made steel-plate engraving possible. The metal had been employed once in England in 1805, in the engraving of the ceiling of the star chamber in Smith's "Topographical Illustrations of Westminster;" but its hardness prevented its general use. Since Perkins's invention steel plates have gradually supplanted copper, and now no artist who understands the relative capabilities of the two metals uses the latter for fine engraving. Another invention of Perkins's, the transferring process, effected a still greater revolution in the art, more especially in the production of small engravings, such as vignettes and other cuts for bank notes. Its advantage is that the plate, after being engraved in the usual manner, can be used to transfer the design to other plates, so that an indefinite number may be produced from the original. The softened plate when finished is reconverted into steel, and a decarbonized cylinder large enough to receive the impression is then rolled over it by means of a powerful machine until the engraved impression appears on it in relief. The cylinder is then hardened, after which it can be used for returning the impression to softened plates, each of which will be an exact counterpart of the engraved plate. The original thus serves to give but one impression to the transfer roller, which in turn is used to make any number of plates. The most important application of this process is for engraving bank notes, which branch of the art is treated below. The plates of notes are transferred usually in parts, a single vignette or figure at a time. In some cases the entire plate has been put on the roller, but to do this successfully requires the utmost care on account of the spreading of the softened steel under pressure.—*Bank-note En-*

*graving.* The art of engraving owes some of its most important developments to the efforts of artists and mechanics in manufacturing bank notes. In the United States this business has nearly attained perfection, and whatever skill has been shown in Europe in bank-note engraving has been the result of improvements introduced from this country. The rude, cheap notes issued by the bank of England a century and a half ago were reproduced for nearly a hundred years, when frequent forgeries rendered a change necessary. In the year 1800 the directors first endeavored to furnish notes which should be secure from counterfeits, but forgeries multiplied, and it was not till 1820 that any remarkable improvement was made in the style of engraving them. In the United States a superior system had existed for some years. The continental notes, the first of which were issued in 1775, were engraved on copper by Paul Revere of Boston. They were of no importance as works of art, and the notes engraved afterward for the bank of North America were little better; but the invention of the transferring process by Perkins raised bank-note engraving to the rank of a special art. Perkins acquired so great a reputation as a manufacturer of bank-note plates that in 1808 a special law was passed in Massachusetts directing the use of a peculiar style of note with a "stereotype check," invented by him, by all the banks of the commonwealth. This, though a sufficient protection against counterfeiting at the time, grew so familiar in 20 years that fraudulent imitations became numerous, and the law was finally repealed. About 1814 Perkins associated himself in Philadelphia with the firm of Murray, Draper, and Fairman, with whom he remained several years, still experimenting with his machinery. While he was there Asa Spencer, who was connected with the same firm, invented a method of applying lathe work to bank-note engraving. This adaptation of the geometric lathe, although but a new application of an old principle, was made so successfully that Spencer received as high credit as if he had been the original inventor. To Mosley I. Danforth also, a native of Hartford, Conn., who spent 12 years in the study of his art in London and Paris, is due much credit for the rapid advancement of bank-note engraving in this country. He associated himself with Murray, Draper, and Fairman, and compelled rival engravers to adopt a higher standard by the exquisite style and finish of his work. In 1818 Mr. Perkins, attracted by the liberal propositions for competition offered by the bank of England, went to London, accompanied by Mr. Fairman and a number of experienced workmen. The superiority of his work was immediately perceived, but not so readily acknowledged; and unfortunately for his prospects, a London wood engraver, Mr. Darton, succeeded after many efforts in making a woodcut copy of one of his pieces of lathe work, a circumstance which was so strongly

urged as an argument against the American competitor that he was obliged to withdraw from the contest, and the privilege of manufacturing the notes was awarded by the bank to Messrs. Applegarth and Cowper in 1820. But so confident was Mr. Perkins in the security of his notes, that when supplying a bank in Ireland he voluntarily agreed, if they should be forged, to furnish a new issue without charge. Perkins remained in London, where he established a partnership with Mr. Heath, an eminent engraver, which lasted during his life. His improvements were adopted in England and in some parts of the continent; but bank-note engraving has been much less developed in Europe than in the United States. In the bank of England security against counterfeiting is sought by the use of a peculiar kind of paper rather than by fine engraving. The notes are printed from an electrotype surface, a method fatal to delicacy of work, although possessing the advantages of speed and cheapness. By this system, introduced by Mr. Smee in 1854, the engravings are used as moulds from which electro-casts are taken, and the notes are printed from these upon steam presses. The paper is made by hand in moulds which are just large enough to form a sheet for two notes. After printing, these notes are separated by an irregular cut, so that each has a selvage on three sides and on the fourth an indented edge. The notes of the bank of France are printed also from a surface, but they are neater in engraving and more elegant in execution than those of the bank of England. The artistic perfection which characterizes bank-note engraving in the United States is the result of a public necessity growing out of our banking system. Under the old local system the issues were so numerous that familiarity with the different notes became impossible; and as the laws furnished no sufficient protection against counterfeiting, other means had to be adopted for security. This was attained in the superior execution of the notes themselves, and by the combination of the highest artistic excellence with mechanical skill, perfect counterfeiting is rendered almost impossible. The business of bank-note engraving is carried on in the United States by three companies, the "American," incorporated in 1858, the "National," in 1859, and the "Continental," in 1862, all of which are in the city of New York. A large part of the bank notes, bonds, and postage and revenue stamps used by many of the principal nations of the world are made by these corporations. Among the foreign nations for which work has been done are Russia, Sweden, Italy, Greece, Spain, Switzerland, the British North American provinces, Cuba and other West India islands, United States of Colombia, Venezuela, Ecuador, Mexico, the states of Central America, Brazil, Peru, Bolivia, Chili, Argentine Republic, Paraguay, Uruguay, Japan, and the Hawaiian islands. The national currency and legal-tender notes



of the United States, the national bonds, and the revenue and postage stamps, are all made in whole or in part by them. To insure greater security, most of the currency is engraved and printed in three establishments, the same notes passing through two of the companies here and then going to Washington, where they are finished.—The American bank-note engraver confines himself to line engraving on steel; stipple, mezzotint, aquatint, and other methods not being suitable for his purposes. In order to attain the greater security against imitation, the engravings are made elaborately fine, from drawings by the best artists, and the plates are decorated with geometric designs cut by machinery with an exquisite minuteness and regularity impossible to be accomplished by hand. Prominent among American designers of vignettes are the names of A. B. Durand, J. W. Caslear, James D. Smillie, F. O. C. Darley, and James Macdonough. The drawing of a vignette is made much larger than the intended engraving, and it is finished with the most elaborate attention to detail. This design is then reduced, by copying on a daguerreotype plate, to the size required for the bank note. It passes now into the hands of the engraver, who traces with a steel point on the daguerreotype plate the outlines of the picture. An impression is then taken on paper from this plate, and while the ink is still fresh the outline engraving thus obtained is laid face downward on a softened steel plate and passed through the press. The exact outline is thus transferred to this plate, which is then treated like any other line engraving. After the engraver's work is done the plate is hardened by restoring its carbon. This plate is never printed from directly, but is retained as a die, to be reproduced by the Perkins process. The cost of engraving an ordinary vignette is from \$300 to \$400, but large and elaborate ones are more expensive. The time required is from one to two months. The principal vignette engravers in the United States now are James Smillie, Charles Burt, Alfred Jones, W. W. Rice, F. Gursch, S. A. Schoff, Louis Del Noce, and James Bannister. There are usually from two to three vignettes on the face of a bank note, each of which is engraved originally on a separate plate. The machine work, technically called "counters," on which the denominational numbers are engraved, as well as the other lathe ornamentation, is done also on separate plates, which are hardened for dies. A bank-note company always has on hand a large number of these dies of vignettes and other designs, and new ones are continually produced. The designs made by the various machines in use cannot be imitated excepting by similar machines, and these cannot easily be procured by counterfeiters. The lathe invented by Spencer has been perfected to a degree undreamed of by him. A first-class lathe costs about \$5,000. Many of its parts are as nicely constructed as the works of a watch. It

moves with the most accurate minuteness, and can be adjusted to engrave figures of almost microscopic delicacy of detail. In making new designs the operator experiments on smoked glass, which being held to the light shows the pattern produced. If satisfactory it is reproduced on soft steel, to be afterward hardened into a die. Parallel lines are engraved by the plain ruling machine, which works also with mathematical accuracy. By the medallion ruling machine any coin or medal, or any figure, whether cameo or intaglio, may be reproduced on a plane surface. This machine is not used now, as cheaper ones that will do similar work are made in Germany. The cycloidal machine invented by Cyrus Durand, now also in disuse, is capable of doing very fine work. A machine called the "geometrical pantograph," patented in this country in 1866, is the invention of Edmund Oldham, formerly an engraver in the bank of Ireland, but now of New York. It is remarkable for its capabilities, being able to reproduce any design either of the same size as the original, larger, or smaller. Like the medallion ruling machine, it is guided by the hand. After the lathe-work patterns have been cut on the soft steel, a part of the centre of the counter large enough for the denominational figures is smoothed by erasing the design. As this portion is then a little lower than the surrounding surface, it is forced up by blows of a hammer on the back, and the figures are engraved on it by hand. The distinctive name of the bank and other large letters are also engraved by hand. In designing a new bank note, impressions from various vignettes and counters are made on paper, and the pieces are fitted together by the modeller in such a manner as to leave appropriate spaces for the lettering and signatures. When a satisfactory design is secured, the next process is to transfer the several plates which make up the note to the plate from which the notes are to be printed. The latter is large enough usually to contain four notes, each of which is produced on it by successive rollings under the cylinders. This large plate is not hardened like the original, but is printed from in its soft state, and is capable of producing about 60,000 impressions before becoming impaired by wearing.—The printing of bank notes demands extreme care at every step. The ink must be nicely ground and mixed, and of the finest quality. Formerly the best black ink was made from Frankfort black, a charcoal obtained from grape and vine lees, peach kernels, and bone shavings; but now it is usually prepared by calcining sugar in an air-tight iron vessel. If the notes were printed in black alone, they could easily be reproduced by photography. To guard against this, many devices have been employed. At one time several colors were used, but it was found that all the tints could be removed chemically from the paper without destroying its texture. At last

a green ink was invented, made from the anhydrous sesquioxide of chromium, which filled the required conditions; it could not be removed without destroying the black ink with it. This practically prevents counterfeiting by photography, for green acts the same as black on the photographic plate. This green ink was used for several years in printing the United States money, but it was finally discarded because it wore down the plates so fast that it increased largely the cost of producing the notes. When different colors are used, separate plates are required for each tint, only one of which is printed at a time. A good workman can make from 500 to 600 impressions in a day, whereas by the electrotype process of the bank of England 3,000 can be produced in an hour. After printing, the notes are dried by artificial heat in the drying room. This process, which formerly required a week, is now accomplished in a few hours. They are then smoothed between pasteboards by hydrostatic pressure.—To lessen the tedious mechanical operations connected with engraving, attempts have been made to obtain directly from the drawings, by chemical means, engraved daguerreotypes and photographic negatives for printing. Various processes have been devised, both in the United States and in Europe, to effect this object, some of which have met with a good measure of success. (See PHOTOGRAPHY.)

**ENKHUISEN**, a seaport town of the Netherlands, in the province of North Holland, on a small peninsula in the Zuyder-Zee, 27 m. N. E. of Amsterdam; pop. in 1867, 5,625. It has several churches, a fine town hall, several salt refineries, and a large cannon foundry. The town was formerly more important than at present, and it is said to have had at one time about 40,000 inhabitants. The harbor, being filled up with sand, is now nearly useless.

**ENEMOSER, Joseph**, a German physiologist, born at Hintersee, in the Tyrol, Nov. 15, 1787, died at Egern, Upper Bavaria, Sept. 19, 1854. In early life he was a shepherd, but his love of learning induced several clergymen to send him to a gymnasium and afterward to the university of Innspruck. Among his classmates was the celebrated Hofer, whom in 1809 he followed in the Tyrolese insurrection as secretary. At its close he resumed his studies, but in 1812 made an unsuccessful effort in England to raise means for its renewal, and then entered the Prussian service, distinguishing himself in the campaigns of 1813-'14 as commander of a company of Tyrolese, and especially as a staff officer. On the conclusion of peace he resumed his studies at Berlin, graduated as doctor of medicine in 1816, officiated from 1819 to 1837 as professor in Bonn, afterward practised his profession at Innspruck, and in 1841 removed to Munich, where he gained a high reputation by his skill in the practical application of animal magnetism and by his writings on medical and physiological science. His most important

works are: *Der Magnetismus* (2d ed., Leipsic, 1844; translated into English by William Howitt, under the title of "Natural History of Magic," 2 vols. 12mo, London, 1854), and *Der Magnetismus im Verhältniss zur Natur und Religion* (2d ed., Tübingen, 1853).

**ENNIS**, a parliamentary and municipal borough and market town of Ireland, capital of the county Clare, on the river Fergus, 20 m. N. W. of Limerick; pop. in 1871, 6,101. The town is irregularly built, and the ruins of an ancient Franciscan abbey, founded in 1240, form its only noticeable architectural feature. It has three bridges across the Fergus, manufactories of linen and flannel, a valuable limestone quarry, large flour mills, and considerable trade in agricultural produce. The Roman Catholic chapel of Ennis is considered the cathedral of the diocese of Killaloe. On the site of the old court house there is a monument to O'Connell with a colossal statue by Cahill. Near the town is a county lunatic asylum.

**ENNISCORTHY**, a market town of Ireland, in the county and 13 m. N. W. of the city of Wexford, on both banks of the river Slaney, and on the railway from Dublin to Wexford; pop. in 1871, 5,804. The Slaney, which here becomes a deep and navigable stream, is crossed by a bridge of six arches. The town contains a castle, a large modern Roman Catholic church, built from the designs of Pugin, several Protestant churches, a woollen factory, flour mills, tan yards, and distilleries, two banks, and two newspapers. At the weekly markets much grain and agricultural produce is sold. Enniscorthy was captured by Cromwell in 1649, and was stormed and burned in June, 1798, by the Irish rebels, who a few days later were completely routed in the battle of Vinegar hill.

**ENNISKILLEN**, a town and parliamentary borough of Ireland, capital of the county Fermanagh, 89 m. N. W. of Dublin; pop. in 1871, 5,906. It is very picturesquely situated on an island connecting Upper and Lower Lough Erne, and on the adjoining mainland on both sides, which communicate with each other by two bridges. The town has a Roman Catholic and several Protestant churches, county buildings, and two barracks. It manufactures cutlery and straw hats, and there is a weekly market for flax, and others for butter and pork. Three newspapers are published. A railway, 32 m. long, connects the town with Bundoran, a favorite watering place on Donegal bay, near Ballyshannon. The town is noted for the victory achieved here in July, 1689, by its Protestant volunteers, over a detachment of James II.; and it has given its name to a regiment in the British service, which was originally raised from the defenders of the place.

**ENNIUS, Quintus**, the father of Roman literature, born at Rudiae, a village of Calabria, about 289 B. C., died in 169. He claimed descent from a mythical hero, the first settler in his country; and after he had learned the

Pythagorean doctrine of transmigration, he boasted that the soul of Homer dwelt in him. Nothing is known of his life till the close of the second Punic war, when he appears as a soldier in the Roman army, and a friend of the elder Cato, by whom he was taken to Rome. There he taught Greek and Latin, but seems to have held no marked position till in 189 he made the Ætolian campaign under Fulvius Nobilior, gained the esteem of the elder Scipio, and received the rights of Roman citizenship. From this time his learning and the charm of his conversation attracted to his little dwelling on Mount Aventinus the most enlightened citizens. His contemporaries marvelled at his learning, which in thoroughness and extent was surpassed by few of the later Romans. Though a master of Greek literature, he gave a thoroughly national character to his own works. The principal of these, entitled *Annales*, was a poem in 18 books on Roman history, which he treated consecutively from Romulus and Remus to his own times, describing later events with greater fullness. This poem was popularly admired, and was the chief foundation of his fame. Though it appears to have existed in the 13th century, nothing but fragments of it gathered from the ancient writers now remains. These are sufficient to show that Ennius devoted great attention to his language, and contributed much toward harmonizing and perfecting the yet rough and uncultivated Latin dialect. He also wrote tragedies and comedies, and adapted the masterpieces of Æschylus, Sophocles, and Euripides to the Roman stage. Among his numerous short pieces, his epigrams, three of which, extending collectively to ten lines, have been preserved, were especially famous. The best collection of the fragments of Ennius is by Hesselius (4to, Amsterdam, 1707).

**ENNS**, or *Ens* (anc. *Anisus*, or *Anesus*), a river of Austria, rises in the province of Salzburg, on the northern slope of a branch of the Noric Alps, 12 m. S. of Radstadt, flows N. past that town, then E. N. E. through Styria, then N., partly separating the provinces of Upper and Lower Austria, and after a total course of about 120 m. enters the Danube 2 m. below the town of Enns. Its principal affluent is the Steier on the left. It is navigable to Hiefelan, about 60 m., and its upper part lies amid wild mountain scenery. Its chief value is in its great water power. The archduchies of Upper and Lower Austria are often distinguished as Austria above the Enns and Austria below the Enns.

**ENNS**, or *Ens*, a town of Austria, on the left bank of the river Enns, a little above its junction with the Danube, 9 m. E. S. E. of Linz; pop. in 1869, 3,784. It has two churches and a handsome council house, and manufactories of iron, steel, and cotton goods. The walls of the town were built with the ransom money paid for Richard I. of England. Enns occupies the site of the Roman station Lauriacum,

which was the scene of a cruel persecution of the Christians by Galerius in 304. A battle between the French and Austrians took place here Nov. 5, 1805. Near the town is the old castle of Ennseck, containing many Roman antiquities and belonging to the princes of Auersperg.

**ENOCH**, the son of Jared and father of Methusaleh, born, according to the Biblical chronology, A. M. 622. He is called "the seventh from Adam" (Jude 14), to distinguish him from Enoch the son of Cain, who was the third from Adam. Eusebius infers from the title "father of astronomy," given him by an old writer, that he is the same whom the Greeks worshipped under the name of Atlas. We read in the Scriptures that "he walked with God;" and as to his departure from the world, we are told that "he was not, for God took him." His character is drawn by two apostles, Heb. xi. 5, 13, and Jude 14, 15. The latter passage has been the subject of much controversy, as it refers to a prophecy by Enoch, part of which it cites apparently in the language of the prophet himself. A prophetic work called the "Book of Enoch" is frequently mentioned in the patristic writings. It is noticed by Justin Martyr, Irenæus, Clement of Alexandria, Tertullian, Origen, Augustine, Jerome, Hilary, and Eusebius. Most of these considered it apocryphal, though Tertullian maintained its authenticity and defended it from the criticisms of his contemporaries. Bruce, the traveller, brought from Abyssinia three copies of the book in the Ethiopic language, which immediately excited great interest in Europe. Sylvestre de Sacy translated portions of it, and a complete English version by Dr. Laurence, professor of Hebrew at Oxford, appeared in 1821. In 1833 a second, and in 1838 a third revised edition appeared. The book is supposed to have been originally composed about the time of the Christian era, in the Hebrew or Chaldee language. The Ethiopic version was not made from the Hebrew, but from a Greek translation which is not now extant. It consists of a series of revelations supposed to have been given to Enoch and Noah, and is divided into five discourses. The first describes the fall of the angels, the judgment upon them and their offspring the giants, and the journey of Enoch through the earth and heaven in company with an angel. The second contains the parables in which Enoch relates the revelations of the spiritual world. The third treats of astronomy and the changes of the seasons. The fourth describes a dream in which Enoch beheld the course of events from the beginning to the coming of Messiah. The fifth consists of exhortations based upon the preceding parts. The best edition is Dillmann's, who published the Ethiopic text from five MSS. in 1851, and a German translation and commentary in 1853.

**ENRIQUEZ GOMEZ, Antonio**, whose real name was ENRIQUEZ DE PAZ, a Spanish dramatist, born in Segovia early in the 17th century.

He was the son of a converted Portuguese Jew, lived much in France, became a captain in the Spanish army, and fled from Spain to escape the inquisition on account of his alleged Judaism, to which religion he finally returned. His *Siglo pitagórico* (Rouen, 1647 and 1682; Brussels, 1727) is a mystical book, partly in verse and partly in prose, satirizing the ancient doctrine of transmigration; and he wrote other similar works, besides 22 comedies which were very successful on the stage, and some of which resembled Calderon's, especially *A lo que obliga el honor* ("The Duties of Honor"), contained with three other plays in his *Academias morales de las Musas* (Rouen, 1642; Madrid, 1660; Barcelona, 1701). Some of his plays were printed with the name of Calderon, and others with that of Fernando de Zarate, which led to the mistake that he was identical with the latter.—See José Amador de los Ríos, *Estudios históricos, políticos y literarios sobre los Julios de España* (Madrid, 1848).

**ENSINAL**, a S. W. county of Texas, watered by some affluents of the Rio Nueces and Rio Grande; area, 1,610 sq. m.; pop. in 1870, 427, all white. The county is best adapted to stock raising. Water and timber are scarce. In 1870 the county produced 9,556 lbs. of wool, and contained 1,678 cattle and 5,778 sheep.

**ENTAIL**, an expression used in the old books for an estate in tail (mediæval Lat. *fedum talliatum*, from *taliare*, to cut off), signifying a truncated inheritance, as being carved out from a larger estate, or perhaps from the exclusion of certain heirs. For the nature of this species of inheritance, see ESTATE.

**ENTERITIS** (Gr. *έντερον*, an intestine), a medical term denoting inflammation of the mucous membrane of the small intestine. It is most frequent in young children, being a rare disease in adult life. It is marked by redness, softening, and thickening of the mucous membrane, ecchymoses in its substance and beneath it, and serous infiltration of the submucous connective tissue. The symptoms of enteritis are a moderate febrile movement, pain, tenderness, and diarrhoea, with nausea and vomiting. The pain is restricted to a small part of the abdomen, or spreads over its whole surface, according as the inflammation extends to the whole or part of the intestines; it is commonly severest about the navel, and is always increased by pressure. This pain is generally the first manifestation of the disease. The brain usually but not always remains unaffected. As occurring in adults, this is not usually a fatal disease, but generally terminates in convalescence in about a week or ten days from the commencement of the attack. Acute enteritis is distinguished from dysentery, or inflammation of the large intestine, by the absence of tenesmus and the characteristic dysenteric discharges; from gastritis, or inflammation of the stomach, by the comparatively mild character of the general symptoms; and from colic by the presence of tenderness,

diarrhoea, and fever, and the absence of severe spasmodic pain.—The treatment usually adopted is a purgative at the outset, followed by opiates in sufficiently large doses to relieve the pain and diarrhoea, with warm fomentations to the abdomen.

**ENTOMOLOGY** (Gr. *έντομον*, insect, from *έντομος*, cut in, and *λόγος*, discourse), the branch of natural history which treats of insects, one of the classes of articulated animals. That part of the science which refers to the anatomy and physiology of the class will be treated under the head of INSECTS; and the particular descriptions of orders, families, genera, and species will be found under their various scientific and popular titles. This article will be devoted to the history of entomology, and to brief sketches of the principal systems of classification.—In entomology, more perhaps than in any other department of natural history, does the student feel the want of a natural classification; but, as the best authors have devoted very unequal study to different groups, from the impossibility of fully cultivating every portion of the immense field, no classification complete and natural in all its parts can be found. The nearly 100,000 species now described probably do not form one half of the total number in existence. If we take for a basis the comparative ratio which has been found to exist in Germany between insects and plants, that of 2 to 1, and extend this to the whole world, we shall have in round numbers at least 400,000 species of insects inhabiting the earth.—It appears that Aristotle, the father of natural history, separated insects from crustacea, and divided them into winged and wingless, subdividing these last into several natural minor groups so successfully as to excite the surprise and admiration of modern observers. From Aristotle we may pass over a period of 1,800 years, a blank as far as the progress of natural history is concerned, to the middle of the 16th century, when Gesner, a Swiss, revived the study of animals, leaving valuable papers on insects from personal observation, which were published after his death by Mouffet, in 1634. During the next 100 years Aldrovandus divided insects into two chief groups, land and water insects, subdividing them according to the structure of their wings and legs; Hoefnaegel made beautiful figures of them; Redi studied their origin and mode of propagation; Malpighi made a careful dissection of the silkworm; Goedart and Vallisneri described the metamorphoses of insects; Leeuwenhoek examined them microscopically; and Mme. Mérian studied the development of the lepidoptera, going to Surinam in her scientific zeal to continue her observations among the most gorgeous species. The writings of Swammerdam, a Dutch naturalist in the middle of the 17th century, created a new epoch in the annals of entomology. He studied the metamorphoses of insects, and from these introduced the first attempts toward a natural

classification. His system was as follows: I. Insects without a metamorphosis, changing their skin but not their form, as spiders, lice, wood lice, and myriapods. II. Insects with a metamorphosis: *a*, those moving in all stages of existence, at first wingless, then with rudimentary and finally with entire wings, including what are now called *neuroptera*, *orthoptera*, and *hemiptera*; *b*, motionless in the pupa state, but having limbs, including the *hymenoptera*, *coleoptera*, and *lepidoptera*; *c*, ovate pupæ, wingless and motionless, as the *diptera*.—John Ray, an English clergyman living in the latter part of the 17th century, was the first true systematist, and doubtless furnished Linnæus with many of the ideas afterward successfully worked out by him. In a "History of Insects," published after his death in 1705, is the following arrangement: I. Insects without metamorphosis, including—1, *apoda* (annulate worms) terrestrial and aquatic; 2, *pedata*, including the terrestrial (lice) and aquatic hexapods, the octopods (spiders), lobsters and crabs, the terrestrial polypods (centipedes and wood lice), and the aquatic polypods (*amphipoda* and *isopoda* of Latreille). II. Insects with metamorphosis, including—1, those with moving larvæ and pupæ (*orthoptera* and *hemiptera*); and 2, those with motionless pupæ, as *coleoptera*, *lepidoptera*, *diptera*, and *hymenoptera*. III. Insects with simple metamorphosis, moving through most of the stages, like the dragon flies.—Réaumur, in the early part of the 18th century, published his *Mémoires pour servir à l'histoire des insectes*, affording valuable information on the habits of insects, but wanting in systematic arrangement. About the same time, in 1735, appeared the *Systema Naturæ* of Linnæus, who displayed in the classification of insects the same intuitive perception of the characters of groups that is observable in his other branches of the animal kingdom. His system is based on the characters of the wings and the presence or absence of a sting, as follows: I. Insects with four wings, including the following orders: 1, *coleoptera*, with the anterior wings crustaceous, with a straight suture; 2, *hemiptera*, with semicrustaceous incumbent anterior wings; 3, *lepidoptera*, with all the wings covered with scales; 4, *neuroptera*, with all the wings membranous, and with no sting in the tail; 5, *hymenoptera*, with membranous wings and tail armed with a sting. II. Insects with two wings, comprising, 6, *diptera*, with poisers in place of the posterior pair. III. Insects with neither wings nor elytra, including, 7, *aptera*, in which were placed by Linnæus the hexapod lice, fleas, &c., spiders, crabs, and centipedes. The fault of this system is its exclusive principle of division drawn from the wings, which placed among the *aptera* animals far removed from insects proper.—De Geer, a Swede, published a work on insects between 1752 and 1778, having the same title as that of Réaumur, of which it may in some respects be considered the sequel; his system is intermediate between

that of Linnæus and that of Fabricius, who came after him, being based both upon the organs of flight and those of manducation, and according to Mr. Kirby is more natural than that of either of the above named naturalists. It is as follows: I. Insects with wings, *alata*, including—A. *Gymnoptera*, or those with four wings without cases, with the subdivisions: 1, *lepidoptera*, with scaly wings and spiral tongue; 2, *elingula*, with naked membranous wings, no teeth nor tongue (*trichoptera*, *ephemerina*); 3, *neuroptera*, with membranous, equal, reticulated wings, and teeth in the mouth (as *libellula* and other Linnæan *neuroptera*); 4, *hymenoptera*, with membranous unequal wings, teeth in the mouth, and a sting or borer in the females; 5, *siphonata*, with membranous wings and tongue bent beneath the breast (*homoptera* of Leach), including the *aphides* and *cicadæ*. B. *Vaginata*, or those with two wings covered by elytra, with the subdivisions: 6, *dermaptera*, with elytra half coriaceous and half membranous, crossed, a pair of membranous wings, and tongue bent beneath the breast (*hemiptera* of Leach), as the bugs and water bugs; 7, *orthoptera*, cockroaches and grasshoppers; 8, with teeth in the mouth, and the wings of beetles (*coleoptera*). C. *Diptera*, with two uncovered wings, including—9, *halterata* (the *diptera* of Linnæus), having a pair of poisers, mouth with a tongue without teeth; 10, *proboscidea* (like the genus *coccus*), with no poisers, tongue, or teeth in the male, and no wings, but a tongue in the breast of the female. II. Insects without wings, *aptera*, including—D. *Saltatoria*, with the subdivision: 11, *suctoria* (*culex*), undergoing metamorphosis, with six legs, and mouth with tongue, the *aphaniptera* of Kirby. E. *Gressoria*, with the subdivisions: 12, *avcenata*, undergoing no metamorphosis, with six legs, and head and trunk distinct, as *termes*, *pediculus*, *psocus*; 13, *atrachelia*, spiders and crabs; 14, *crustacea*, as isopods, amphipods; and myriapods. This system, though not purely artificial, and founded on several correct principles, is yet far from natural, and includes among insects animals which do not belong with them; his 14 orders comprised only about 1,500 species, referable to 100 genera.—Geoffroy, in France, in 1762, published a system which is important from the introduction of the joints of the tarsi as a means of classification; he makes only six groups, *coleoptera*, *hemiptera*, *lepidoptera*, *te-traptera*, *diptera*, and *aptera*, the third, fifth, and sixth being the same as the Linnæan; it is an exceedingly unnatural system.—Fabricius, a German, a pupil of Linnæus, introduced important improvements into the science during the last quarter of the 18th and the beginning of the 19th century; his system is based upon the number, proportions, form, and situation of the parts which constitute the mouth, without regard to other parts of the insect; by building upon this narrow foundation he departed widely from nature, though by drawing

attention to the maxillary system he has enabled his successors to define certain groups with considerable accuracy. His first classification

of 1775 was greatly modified in the course of his life, and the following was proposed by him in his *Entomologia* in 1798:

- I. INSECTS WITH BITING MOUTHS.
- A. Two pairs of mandibles.  
 a. The lower ones having palpi.  
 1. Free without covering..... 1. Class *eleutherata* (beetles).  
 2. Covered..... 2. " *ulonata* (*orthoptera*).  
 3. Connate with the labium..... 3. " *synistata* (*neuroptera*).  
 4. Distended, thin, coriaceous..... 4. " *piezata* (*hymenoptera*).  
 5. Horny, strongly toothed, labium without palpi..... 5. " *odonata* (*libellula*).  
 6. " *mitosata* (*scolopendra*).  
 b. All without palpi..... 6. " *unogata* (scorpions and spiders).  
 B. A pair of scissor-like maxillæ..... 7.  
 C. More than two pairs of maxillæ.  
 1. Within the labium..... 8. " *polygonata* (*isopoda*).  
 2. Outside the lip, closing the mouth..... 9. " *pleistagnatha* (short-tailed crabs).  
 3. Outside the lip, but covered by the palpi..... 10. " *eeochmata* (long-tailed crabs).
- II. INSECTS WITH SUCTORIAL MOUTHS.
1. In the mouth a spiral tongue..... 11. Class *glossata* (*lepidoptera*).  
 2. A horny proboscis, with jointed sheaths..... 12. " *rhynchota* (*hemiptera*).  
 3. A soft, unjointed proboscis..... 13. " *antliata* (*diptera*).

The facility with which genera were determined by this system secured for it many followers, in spite of its unnaturalness; and Illiger, by uniting it with that of Linnæus, considerably improved it. He made order 1 of Linnæus correspond with class 1 of Fabricius; 2 L. with 2 and 12 F.; 3 L. with 11 F.; 4 L. (to which were added *termes*, *lepisma*, and *podura*) with 3 and 5 F.; 5 L. with 4 F.; 6 L. (with *pediculus* and *acarus*) with 13 F.; and 7 L. (without the above named apterous genera) with 6, 7, 8, 9, and 10 F.—Olivier, in the article *Insectes* in the *Encyclopédie méthodique*, follows chiefly the Linnæan classification, modified by Geoffroy and De Geer, making use of the wings and elytra, the parts of the mouth, and the joints of the tarsi in his divisions; he substituted the term *orthoptera* for the *dermaptera* of De Geer; in his order *aptera* are still included spiders, crabs, and myriapods. In Olivier's great work on *coleoptera*, in six large quarto volumes with nearly 400 plates, published between 1789 and 1808, may be found the largest collection of representations of this order yet known.—Latreille's first work, published in 1796, presents the insects of Linnæus in 14 classes, adding *orthoptera* to the Linnæan system, and separating the *aptera* into *suctoria*, *thysanoura*, *parasita*, *acephala*, *entomostraca*, *crustacea*, and *myriapoda*; this system, though in many respects unnatural, claims the positive merit of introducing some natural families. In 1810 he adopted a new classification, following Cuvier and Lamarck in separating crustacea and arachnids from insects proper, and dividing the latter into the 7 orders of his first classification, adding the order *suctoria* (formed entirely by the genus *pulex*). In 1817 he added *myriapoda*, *thysanoura*, and *parasita* to his 8 orders, and also *strepsiptera* of Kirby; in 1825 he raised the *myriapoda*, after Leach, to a distinct class, and divided the *insecta* into 11 orders; in 1829 he reduced the *myriapoda* to an order among insects, raising the number again to 12 orders, and in 1832 raised them again to a class intermediate between arachnids and insects. One

great merit of Latreille is that he gave family names to the groups of genera, which Macleay has reduced to system by giving to them the termination *idæ*, which, if not always classically correct, is of advantage for uniformity and euphony.—Lamarck divides insects into 8 orders: 1. Insects with suctorial mouths: 1, *aptera* (*suctoria*, Latr.); 2, *diptera*; 3, *hemiptera*; 4, *lepidoptera*. II. Insects with mandibulate mouths: 5, *hymenoptera*; 6, *neuroptera*; 7, *orthoptera*; and 8, *coleoptera*. Other *aptera* he placed among arachnids and crustacea, and ranked *thysanoura*, *myriapoda*, and *parasita* among arachnids.—Duméril places insects above mollusca in the animal series, and comprises among them arachnids and myriapods; his arrangement differs but little from the Linnæan; he endeavored to reunite the greatly divided families, and to reduce the number of genera.—The philosophical systems of the modern German school proceed on the view that organic nature is one great whole, exhibiting progressive grades of development, which are characterized as classes. Oken has made 13 classes of animals, each represented by a successively added organ. Insects form the 9th class, and are called lung animals; they are divided as follows: I. Germ flies, with perfect metamorphosis, with tribes: 1, *hemiptera*; 2, *orthoptera* and *dermaptera*; 3, *neuroptera*. II. Sexual flies, with perfect metamorphosis and equal wings, with tribes: 4, *diptera* and *suctoria*; 5 *hymenoptera*; 6, *lepidoptera*. III. Lung flies, beetles, with perfect metamorphosis, elytra, and wings, with tribes: 7, *C. tetramera*; 8, *C. heteromera*; and 9, *C. pentamera*.—Among the English writers who have contributed to the advance of entomological classification may be mentioned Leach, Kirby, and Macleay. Dr. W. E. Leach published several elaborate treatises on insects in the "Linnæan Transactions," and in the British and foreign encyclopædias; his system is sketched in vol. iii. of the "Zoological Miscellany." He divides insects into *ametabola* and *metabola*, according to the absence or occurrence of metamorphosis, the former including 2 and the latter 14 orders;

he subdivides *orthoptera* into 3 orders, adding *dermaptera* (*forficula*) and *dictyoptera*, and introduces also *omoptera* and *omaloptera*. The classification of Kirby and Spence, as given in vol. iv. of the "Introduction to Entomology" (1815-'26), is as follows: I. *Mandibulata*, or insects with mandibles, containing the orders: 1, *coleoptera*; 2, *strepsiptera*; 3, *dermaptera*; 4, *orthoptera*; 5, *neuroptera*; and 6, *hymenoptera*. II. *Haustellata*, or insects with suctional mouths, containing the orders: 7, *hemiptera*; 8, *trichoptera*; 9, *lepidoptera*; 10, *diptera*; 11, *aphaniptera*; and 12, *aptera* (all wingless insects breathing through tracheæ). It has been objected to this system that the 3d order is improperly separated from the 4th, and that the 8th forms naturally a part of the 5th. The system of Macleay is founded on the following principles: 1, all natural groups return within themselves, and consequently present themselves in the form of circles; 2, each of these circles contains five others, connected in the same way; 3, where the circles join, there are intermediate groups connecting them more closely; 4, the members of each, at the points where the circles meet, exhibit analogies. The animal kingdom consists of five circles, one of which, the *annulosa* (crustacea and insects), consists of five principal groups, which may be represented as follows:

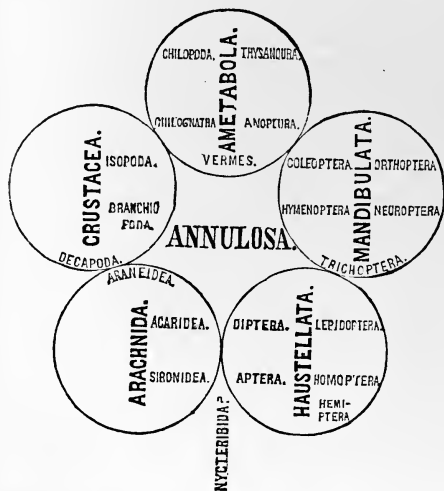

The three orders of *ametabola*, *mandibulata*, and *haustellata* only concern us here. Of the first, the myriapods join the *crustacea*, and the *thysanura* and *anoplura* (*parasita*) join the *mandibulata*. The *haustellata* and *mandibulata* he calls *insecta ptilota*; the former include *lepidoptera*, *diptera*, *aptera* (*suctoria*, Latr.), *hemiptera*, and *homoptera*; the latter include *trichoptera*, *hymenoptera*, *coleoptera*, *orthoptera*, and *neuroptera*. These two circles are contiguous in the *trichoptera* and *lepidoptera*, the genus *mystacides* (Latr.) of the former making the transition to *aglossa* (Latr.) of the

latter. Space will not permit the introduction of the families which he considers the connecting links between the orders of the two great divisions. This system, while it has many forced and unnatural affinities, presents much that is valuable in determining the groups of transition, which are found among insects as among other branches of the animal kingdom. His principal work, *Horæ Entomologicae*, was published in 1819-'21.—Burmeister divides insects, according to the completeness of their metamorphosis, into *ametabola* and *metabola*, each group presenting both *haustellata* and *mandibulata*, and subdivided according to the form of the larva, the structure of the wings, and the internal organization. His system is as follows: I. *Insecta ametabola*, with imperfect metamorphosis; the larva, pupa, and perfect insect resembling each other, the pupa eating and moving about: A. Having a suctional mouth, with four fine setæ enclosed in a sheath, and the palpi wanting, with order 1, *hemiptera* (bugs). B. With a masticating mouth: *a*, with four unequal wings, anterior ones leathery, the posterior membranous and folded longitudinally and once transversely; prothorax free, and many biliary vessels; with order 2, *orthoptera* (locusts); *b*, with four generally equal wings, never folded, with order 3, *dictyoptera* (cockroaches). II. *Insecta metabola*, with perfect metamorphosis; the larva a worm, of 13 segments, with or without legs; the pupa motionless, or, if it moves, not eating. A. With suctional mouth: *a*, with two naked transparent wings, the posterior replaced by pediculated knobs; four biliary vessels; larvæ without feet; soft proboscis, with several setæ and a pair of palpi; prothorax not free; with order 4, *diptera* (flies); *b*, with four wings, generally covered with scales, six biliary vessels; larvæ with feet and a distinct head; the maxillæ forming a spiral tongue; prothorax not free, but closely connected with the mesothorax; with order 5, *lepidoptera* (butterflies and moths). B. With masticating mouth, or at least visible mandibles and palpi: *a*, with four equally large or long wings, with reticulated nervures; rarely more than eight biliary vessels; prothorax always free; with order 6, *neuroptera* (dragon flies); *b*, with four unequal wings, with variously branching nervures; larvæ generally without head or feet, yet sometimes with both; many biliary vessels; prothorax not free; with order 7, *hymenoptera* (bees, wasps); *c*, with four unequal wings, the anterior ones corneous; larvæ with head, with or without feet; four or six biliary vessels; prothorax always free; with order 8, *coleoptera* (beetles). In almost all these orders there are apterous families, genera, and species, whose place may be determined by their metamorphosis and the structure of the mouth; but they never form a distinct order like the *aptera* of Latreille. Burmeister maintains that all true insects undergo some metamorphosis, though in the apterous forms it may be difficult to detect it from the

absence of the wings; as his idea of an insect necessitates metamorphosis, however imperfect, he gives the name *ametabola* (applied by Leach to apterous insects) to all those with an imperfect metamorphosis, as there is no real difference in the process of development in each.—Westwood, in his "Introduction to the Modern Classification of Insects," in 1839, gives the following:

<p>I. MOUTH WITH JAWS. Order <i>hymenoptera</i>. Osculant order, <i>strepsiptera</i>. " <i>coleoptera</i>. Osc. ord. <i>euplexoptera</i>. " <i>orthoptera</i>. " <i>neuroptera</i>. " <i>trichoptera</i>.</p>	<p>II. MOUTH WITH A SUCKER. Order <i>diptera</i>. Osc. ord. <i>homaloptera</i>. " <i>aphaniptera</i>. " { <i>heteroptera</i> (including the water bugs). " <i>homoptera</i>. " <i>lepidoptera</i>.</p>
---	--

—Stephens, in the article "*Insecta*," in vol. ii. of the "Cyclopædia of Anatomy and Physiology" (1839), divides insects into: I. *Mandibulata*, containing *coleoptera*, *dermaptera* (earwigs), *orthoptera*, *neuroptera*, *trichoptera*, (caddis flies), *hymenoptera*, and *strepsiptera*; and II. *Haustellata*, containing *lepidoptera*, *diptera*, *homaloptera*, *aphaniptera*, *aptera*, *hemiptera*, and *homoptera*.—Siebold (Burnett's translation), in 1848, gives the following classification: A. Insects without metamorphosis, *ametabola*, containing—1, *aptera* (*pediculidæ*, &c.). B. With incomplete metamorphosis, *hemimetabola*, containing—*a*, with suctorial mouth: 2, *hemiptera*; *b*, with mandibulate mouth: 3, *orthoptera*. C. With complete metamorphosis, *holometabola*, containing—*a*, with suctorial mouth: 4, *diptera*; 5, *lepidoptera*; 6, *hymenoptera*; *b*, with mandibulate mouth: 7, *strepsiptera*; 8, *neuroptera*; and 9, *coleoptera*. This is the same as the classification of Vogt, founded upon embryological principles; and the orders are the same as those of Owen, as given in the second edition of his "Lectures on the Comparative Anatomy and Physiology of the Invertebrate Animals" (1855), except that *homoptera* is substituted by him for *hemiptera*. The orders of Milne-Edwards, in his *Cours élémentaire d'histoire naturelle* (1855), are nearly the same as Siebold's, except that *aptera* is omitted, *rhypiptera* substituted for *strepsiptera*, and *anoplura* and *thysanoura* are added. The embryological system of Van Beneden (1855) is the same as the last, the term *strepsiptera* being reintroduced, and *parasita* substituted for *anoplura*.—Prof. Agassiz, in the "Smithsonian Contributions to Knowledge" (vol. ii., 1851), gives the following classification of insects from embryological data:

<p>I. CHEWING INSECTS (<i>mandibulata</i>). <i>Neuroptera</i>. <i>Coleoptera</i>. <i>Orthoptera</i>. <i>Hymenoptera</i>.</p>	<p>II. SUCKING INSECTS (<i>haustellata</i>). <i>Hemiptera</i>. <i>Coleoptera</i>. <i>Diptera</i>. <i>Lepidoptera</i>.</p>
--	---

In this the subdivisions are made according to their transformations. From the fact that those undergoing complete metamorphosis have a

chewing apparatus in the early stages of their growth, which is gradually transformed into various kinds of suckers, he expresses the belief that the *mandibulata* are lower than the *haustellata*; and he also ranks *lepidoptera* highest among insects, and not *coleoptera*, as generally maintained. Mr. A. S. Packard, in his "Synthetic Types of Insects" (1872), makes seven sub-orders, viz.: *hymenoptera*, *lepidoptera*, *diptera*, *coleoptera*, *hemiptera*, *orthoptera*, and *neuroptera*.—Mr. Wilson in the article "Entomology" in the "Encyclopædia Britannica," Dr. Burnett in his translation of Siebold, and Mr. Westwood, give valuable lists of the authors on this science, arranged in chronological order; from them we select the following as among the most important writers since Latreille: in England, Donovan, Curtis, Wood, Rennie, Haliday, A. White, Doubleday, Shuckard, Hope, Newman, and Newport; in France, Jurine, Dufour, Godart, Guérin-Méneville, Boisduval, Dejean, Lacordaire, and Blanchard; in Germany, Meigen, Ochseneimer, Klug, Fischer von Waldheim, and Germar; in Sweden, Fallen; in America, Thomas Say, Dr. T. W. Harris, J. L. Leconte, S. H. Scudder, A. S. Packard, and Dr. Hagen. The most useful work on entomology ever published in this country is the "Treatise on some of the Insects of New England which are Injurious to Vegetation," by Dr. T. W. Harris, issued by order of the legislature of Massachusetts; the second edition was published in 1852, and the third, edited by Charles L. Flint, in 1862, with illustrations, at the expense of the state. In this work are adopted the seven following orders, as generally received by naturalists: I. *Coleoptera* (or beetles), with jaws, two thick wing covers meeting in a straight line on the top of the back, and two filmy, transversely folded wings; metamorphosis complete; larvæ generally with six true legs and sometimes with a terminal prop leg, rarely without legs; pupa with wings and legs distinct and unconfined. II. *Orthoptera* (cockroaches, crickets, &c.), with jaws, two opaque upper wings overlapping a little on the back, and two larger thin wings folded in fan-like plaits; transformation partial; larvæ and pupæ active, but without wings. III. *Hemiptera* (bugs and plant lice), with a horny beak for suction; four wings, of which the upper lie flat, cross each other on the back, and slope at the sides like a roof; transformation partial; larvæ and pupæ like the adults, but wingless. IV. *Neuroptera* (dragon flies, May flies, white ants, &c.), with jaws, four netted wings, the hinder the largest; with no sting nor piercer; transformation complete or partial; larva and pupa various. V. *Lepidoptera* (butterflies and moths), with a sucking tube; four scaly wings; transformation complete; larvæ with six true legs, and from four to ten prop legs; pupa with the cases of the wings and legs indistinct, and soldered to the breast. VI. *Hymenoptera* (bees, wasps, ants), with jaws; four veined wings, the hinder pair



generally the smallest; a sting at the end of the abdomen; transformation complete; larvæ like maggots, or slugs, or caterpillars; pupæ with the legs and wings unconfined. VII. *Diptera* (flies, mosquitoes, &c.), with a horny or fleshy proboscis, two wings and two balancers or poisers behind them; transformation complete; larvæ footless maggots, with the breathing holes generally in the hinder part of the body; pupæ usually incased in the dried skin of the larvæ, but sometimes naked, in which case the wings and legs are visible, and more or less free.—Among the smaller groups, the order *strepsiptera* (Kirby), or *rhiniptera* (Latr.), contains minute insects which undergo their transformations within the bodies of bees and wasps; the maggot-like larvæ live between the rings; the females are wingless, and never leave the body of their host; the adult males have two very short members instead of fore wings, and two very large hind wings; the sharp-pointed jaws are adapted for piercing rather than biting. Their systematic position is not precisely determined; Latreille places them between *lepidoptera* and *diptera*, though he thinks them most nearly allied to some of the *hymenoptera*. The order *aptera* (Leach), *suctoria* (De Geer), *siphonaptera* (Latr.), or *aphaniptera* (Kirby), is constituted by the flea tribe, which seem to be intermediate between *hemiptera* and *diptera*. The earwigs, included by most entomologists among *orthoptera*, form the order *dermaptera* (Leach), or *euplexoptera* (Westwood). The spider-flies, ticks, &c., alluded to at the close of the article DIPTERA, form the order *homaloptera* (Leach). The May flies were separated from the *neuroptera* and elevated to an order *trichoptera* by Kirby. The *thysanoptera* of Haliday consist of the minute insects of the *thrips* tribe, generally classed with the *hemiptera*; other *hemiptera*, as the harvest flies, plant lice, &c., have been separated by the English writers under the name of *homoptera*. Burmeister has separated from *neuroptera* those species which undergo only a partial metamorphosis into the order *dictyotoptera*.—Naturalists generally have been disposed to rank insects in the animal scale below mollusca, though many of their vital functions, as of locomotion and perception, indicate a superiority in the former. Mr. Kirby and other English entomologists have accorded the precedence to insects, in opposition to Cuvier and Lamarck, who placed the mollusca first on account of their system of circulation. In the branch of *articulata*, the position of insects is well given by Oken, when he says that "*lepidoptera* are born as worms, then pass into the condition of crustacea, and are finally developed into true insects, exemplifying the natural order of gradation of the three classes of *articulata*." For interesting and conclusive observations on the position that worms are the lowest, crustacea the intermediate, and insects the highest among *articulata*, see the paper by Agassiz, above alluded to, in vol. ii. of the

"Smithsonian Contributions." In vol. i. of "Contributions to the Natural History of the United States," in the highest class (*insecta*) of *articulata* he establishes the three orders of *myriapods*, *arachnids*, and *insects proper*, the last therefore being the highest order of the highest class, and the *lepidoptera* (butterflies and moths) the highest division in this order.

**ENTOMOSTRACA**, the lowest order of crustaceans, deficient in the segments, feet, and abdominal appendages of the higher forms. They have normally five or six cephalic rings, and eight or nine posterior ones belonging to the foot series. They include the *carcinoids*, like *caligus* and *argulus*, minute forms, parasitic or marine and fresh-water fishes; the *ostracoids*, minute forms like the *daphnia* of fresh waters, with the larger marine *cirripeds* or barnacles; the *limuloids*, or horseshoe crabs; and the microscopic *rotifers*, radiate in appearance but crustacean in structure, whose organs of locomotion are cilia around the head. They appeared in the early Silurian age.

**ENTOPHYTES**. See *EPHYPHYTES*.

**ENTOZOA** (Gr. ἐντός, within, and ζῷον, animal), a group of invertebrate animals, which during some period of their existence live within and derive nourishment from the bodies of other animals, and with few exceptions belong entirely to the class of helminths or worms. Animal parasites form in fact a sort of sub-fauna, and their number is only to be estimated by the extent of the animal kingdom. The classification of entozoa has been attempted by many eminent zoologists since the days of Rudolphi, who may be considered the father of helminthology; but only recently, and chiefly through the labors of a few observers in Germany, has it attained the position of a true science. Cuvier refers the entozoa to the class *radiata*, and subdivides them, following the plan of Rudolphi, into *tanioidea* or tapeworms, *trematoda* or flat worms, *nematoidea* or round worms, and *acanthocephala* or hooked worms. More correctly, however, they belong to the *articulata*, though their type is a degraded one, and some of them even approach in structure the *mollusca*. Adopting this arrangement, we can best explain the progress and present state of helminthology by considering these subdivisions separately.—*Tanioidea*, *cestoidea*, *stereelmintha*, tapeworms. These parasites in their mature state inhabit the intestines of all classes of vertebrate animals. In their transitional state or immature stage they occur as cysts in the tissues and organs of such creatures as form the food of their true bearers or hosts. These cysts, of which the measles in swine are an example, in the early days of science were not looked upon as of an animal nature, and were called *hydatids* and *acephalocysts*; and not until the latter part of the 17th century was their true character recognized. In the 18th, many observers, and especially Götze, noticed that their heads closely resembled those of the tapeworms. His observations were

confined chiefly to the tæniæ of animals, and appear to have had little influence with the scientific men of the next century, who fell back again upon the old and easy theory of spontaneous or equivocal generation; and so it remained until 1844, when Steenstrup's theory of alternation of generation was applied to the problem, and Siebold and Dujardin published essays on the connection between the tæniæ and encysted forms of various animals. Their experiments and those of Küchenmeister, who must be considered the highest authority on the human helminths, cannot be given in detail here; suffice it to say that tapeworms have been produced in carnivorous animals of all kinds by giving them the encysted forms to eat, and the encysted varieties have been bred in others by administering the eggs or embryos of tæniæ. Tapeworms consist of three parts, viz.: head, neck, and colony of joints. The head is a minute object, usually square, and provided with varieties of sucking disks and coronets of hooks, by which it attaches itself to the walls of the intestine. The neck is slender and marked by transverse wrinkles, which gradually are converted into joints, which gradually are converted into joints. With age these joints increase in number, and finally those first formed become ripe, while new ones are continually given out from the head to supply in turn the place of those discharged. Their growth is generally rapid, and some species attain a length of 100 ft., while others are only a few lines long. Considered as a simple individual, the tapeworm has very

limited power of motion, although a distinct layer of muscular fibre is found beneath the skin. This integument is soft, white, moist, and porous; and through this nutrition is probably carried on by absorption, though the only organs subservient to this function are two pairs of longitudinal canals running along each side of the joints, and united by transverse branches. The skin contains also innumerable roundish, concentrically marked, calcareous corpuscles, recognized only by the microscope, which serve undoubtedly as a sort of skeleton. They possess no nervous system. The sexual organs, however, are remarkably developed. When the oldest joints have become sexually mature (which period varies greatly in different species), they pass off spontaneously by the anus—sometimes by the mouth—of the animal which harbors them. These are flat, quadrangular, yellowish white, and in some species are detached singly, in others by groups. These proglottides, as they are called, are true hermaphrodites, contain the sexual organs and eggs or embryos enclosed within shells, and possess the power of moving about; so that they have often been mistaken for trematoda,

and in fact are now considered separate individuals. They discharge their eggs either through the genital opening or by self-destruction, which results either from the bursting of their walls or by decomposition. They affect chiefly moist places, and, leaving the manure in which they have been deposited, wander about amid the herbage, and may in this way be devoured; or they fall into water, and there bursting, discharge their eggs, which are thus borne far and wide, and find entrance to a proper soil for future development. They are not capable of a long continued independent existence, and may even be destroyed within the intestine of their host, scattering their eggs along this canal, though harmlessly; for Leuckart found by experiment that eggs introduced into the intestine before being subjected to the action of the gastric juice remain unchanged; but that when previously submitted to its influence and then placed within the intestinal canal, the embryos became free. Proglottides may even be swallowed entire by animals which wallow in moist manure, and thus introduce the eggs to their proper dwelling place. When once they have set their offspring free, their object is accomplished and they disappear. Each proglottis contains a

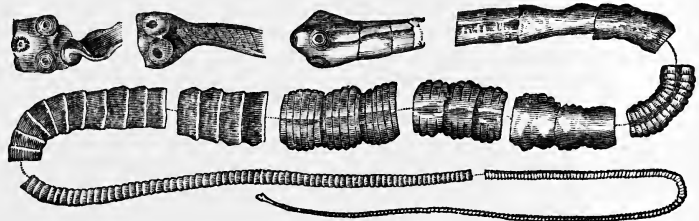

FIG. 1.—*Tænia solium*, with different Views of the Head.

vast number of eggs, so that if one out of the many millions reaches a proper habitation the species will not decrease in numbers. The embryos are enclosed in firm shells constructed to resist a strong pressure from without, and are either brown or yellowish, and round or oval. They probably cannot undergo a great degree of dryness, heat, or cold, or exist very long in fluid, without the destruction of the animal within. The history of the *tænia solium*, or common tapeworm, will best serve as an example of the usual method of development and transformation of the *cestoidea*, for it has been most fully studied on account of its frequent occurrence in the form of measles, and its important relation to man. This worm is improperly named, since many are sometimes found in the same intestine. It seldom attains a length of more than 20 ft., and is composed of 600 or 700 joints, which when mature contain myriads of eggs, and escape singly or at once into the outer world. The eggs being set free find their way into water or manure, and are thus scattered far and wide. One occasionally enters the stomach of man on lettuce, fruit, or unwashed vegetables, but more gen-

erally they are swallowed by the hog, whose filthy and omnivorous habits need only be considered to show how readily it may become infected. In either case the egg shell is destroyed by the process of digestion, and the embryo, a minute globular vesicle, armed in front with three pairs of sharp spines, begins its active migrations. It sets out on its travels by boring into the blood or lymph vessels of the stomach or intestine, and is borne along by their currents till it reaches the capillaries, where it renews its activity and bores its way out of the circulatory system into any organ to which chance has carried it. There can be no doubt about this fact, for Leuckart has discovered the embryo several times in the vena portæ. It is possible that the embryos may in some cases lose their hooklets in the vessels, and thus, being unable to proceed further, become encysted in the capillaries. Having reached thus a proper situation for higher development, it becomes surrounded by a new formation or cyst resembling the structure of the organ it may inhabit. If it happens to penetrate any serous cavity, this cyst is not formed, but otherwise the development is the same. This process goes on rapidly, so that in a week or two the cyst may be recognized by the naked eye. The spines or hooklets now drop off, the primary vesicle goes on absorbing nutriment, and by the second or fourth week a

protuberance grows out from its internal surface, which soon takes the form of the head of the future tænia. Upon this springs up a double circle of small hairs, which in six weeks become the complete double coronet of hooks.



FIG. 2.—Development of a Cyst.  
1. Animal in cyst. 2. Animal with head developed. 3. Head and neck, greatly magnified. 4. Hooklet.

The neck now begins to extend, but the head still remains enclosed in the bladder, till the whole animal is set free. It may continue to live in this encysted stage till it dies of old age, unless set free by nature or art; and this undoubtedly is the fate of the largest portion of these immature creatures. If seated in the muscles, this encysted stage of tapeworm is seldom injurious to man; but if it take up its dwelling place in the brain or eye, which is not unfrequently the case, results most serious follow. In the hog the case is different, for many eggs being devoured at once, the embryos invade nearly every organ of the body, and produce the disease known as measles. We have still to consider the last and highest stage of development in the life of a tænia, viz.: the conversion of these cysts or measles into the mature intestinal worm. When one of these cysts is accidentally swallowed by man, the little pea-like vesicle bursts, and the head of the worm protruding fastens itself to the intestinal walls by its hook-

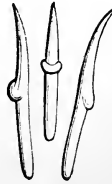

FIG. 3.  
Hooklets of a Cyst, magnified.



FIG. 4.  
Cyst found in Swine.

lets. From this head bud out one after another numerous joints, which finally make up the mature worm. It may be easily understood how these small white cysts gain entrance into the stomach of man, for mealy pork is often sold in markets, and although thorough cooking and curing destroy the larvæ, still the cysts may adhere to the knife, and be thus transferred to vegetables, butter, cheese, and the like, which are eaten uncooked. It may often be the case too that pork is so slightly mealy, that the butcher does not know the disease is present. There can be no question about the identity of these two forms, the *tænia solium* in man and the *cysticercus cellulosæ* or measles in swine; for not only are their heads anatomically the same, but it had for a long time been noticed that where measles in pork were abundant, there tænia was of most frequent occurrence, and that where the use of this flesh was forbidden among nations or sects, there tapeworm was scarcely ever found. All of this led to the belief, especially after the experiments performed in regard to the tænia and cystic worms of the lower animals, that the measles in meat were the cause of tapeworm in man. To settle this point Küchenmeister fed a condemned criminal three days before his execution on raw mealy pork, and on examination after death the young tapeworms were found attached to the walls of the intestine. One point, however, remained to be proved, viz.: that the eggs of the tapeworm produce the measles in swine. For this purpose experiments were undertaken by the Saxon government under the direction of Küchenmeister and other scientific men of Germany. Young and healthy pigs were kept confined separately, and to them were given the eggs of tapeworms. At various intervals they were killed, and the encysted forms were found in myriads throughout the body. These experiments have been often repeated with the same success. To recapitulate: The tapeworm of the human intestine discharges millions of eggs, a single one of which need only reach maturity to produce millions more; therefore it is evident that the vast majority of these eggs perish undeveloped. These eggs must be devoured by some other host to reach their second or encysted stage. This stage is known as measles in swine. Measles being eaten by man in turn produce the tapeworm. These two forms never produce each other in the same individual.

Various other tæniæ infest man in one of their stages, the most dangerous of which is the *echinococcus*, or encysted form of *E. hominis*. The cysts produced by this parasite are often as large as a man's head, causing great suffering and death. In Iceland every seventh person

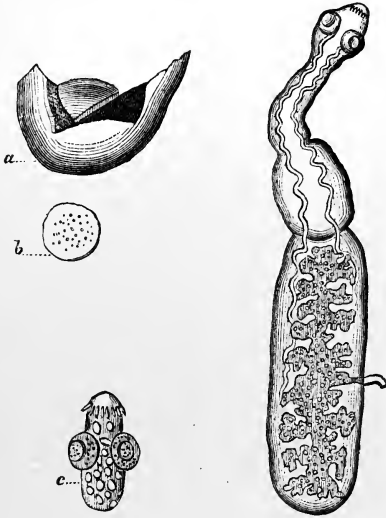

FIG. 5.—*Tænia echinococcus*. a. Cyst, opened. b. Collection of Vesicles or Scolices. c. Single Scoliceus greatly magnified.

is thus afflicted. The explanation lies in the filthy habits of this people, and in the great number of dogs they keep, which assist in spreading the seeds of the disorder. Here the cysts or hydatids contain instead of one *scoliceus* or head innumerable embryonic forms, which of course increases the risk of infection. The mature tapeworm produced artificially consists of but three joints, and on this account has hitherto escaped notice. Even now it is not known whether man himself or dogs are the hosts of the mature helminth. Another remarkable species dwelling in the intestinal canal of man is the *bothriocephalus latus*, or broad tapeworm. This differs from the true

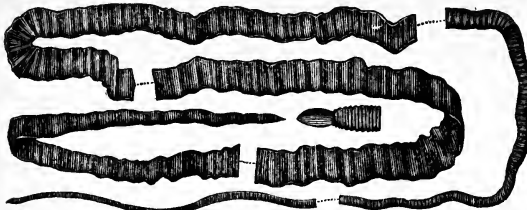

FIG. 6.—*Bothriocephalus latus*, with View of Tail, magnified.

tæniæ in the construction of its head and joints. The former is oval, flat, and instead of a coronet of hooks and round suckers possesses two longitudinal sucking grooves on each lateral margin, by which it fixes itself; the latter are one third of their width only in length, and

the genital opening is found on the middle of each joint, instead of at the lateral margin, as in tæniæ proper, and occurs on the same surface throughout its whole length. They are sometimes as many as 2,000, but even then they do not make up a worm more than 20 ft. long. Thus far this parasite has been found in man only in its mature state. Its geographical distribution is limited to Russia (including Poland), Switzerland, Italy, and the maritime districts of France and north Europe, and it most probably undergoes its transitional stage of development outside the human intestine in some of the mollusks, which form the food of man. A few other species of tapeworm infest mankind, but they are seldom met with, and will be found enumerated in the accompanying catalogue. The dog, from his domestic and omnivorous habits, is made the host of many of these entozoa, and does much to keep up their precarious existence. Without his aid the *tænia caninus* would undoubtedly become extinct, and thus the sheep breeders would be rid of a disease which often proves so fatal to their flocks, viz., the staggers. This disease is caused by the presence in the brain of hydatids or cystic *canuri*, which when eaten by butcher and sheep dogs are converted into the corresponding tænia, the embryos of which are in turn scattered broadcast over the pastures, where they find ready admission to the grazing herds. This too has been made the subject of searching investigation in Germany, and shepherds are taught to keep their dogs free from this tapeworm, by putting out of their reach the flesh of animals afflicted with the staggers. Sheep may often be kept healthy by keeping them from moist places, and from pastures while the dew is still on the grass, for the proglottides seem to seek such localities, and the heat of the sun appears destructive to their vitality. Much more good may be effected by such preventive measures than by administering anthelmintics, or by attempting the removal of the cysts by the trephine or trochar. Very often immense droves of swine have to be slaughtered on account of the measles, and such attacks always prove that the victims

have lately been in the neighborhood of some person who has a *tænia solium*. Wild swine are never affected in this way. Occasionally this variety of *cysticercus* is found in the flesh of other animals eaten by man, as the ox, deer, and bear, but very seldom. No doubt a great deal of mealy pork is sold both fresh and salted, and enough is eaten in an uncooked state in the form of sausages, raw pork, and the like, to account for the wide distribution of tæniæ. Dr. Weinland, in his essay on human *cestoidea* (Cambridge, 1858), divides the *tænioidea* into two classes: First, the *sclerolepidota*, or hard-shelled tapeworms, the embryos of which, developed in the warm-blooded vertebrata, become mature tæniæ only in the intesti-

nal canal of carnivorous mammalia. Thus man obtains the *tania solium* from swine; the dog the *T. serrata*, *T. canurus*, and *T. echinococcus* from the rabbit, the sheep, and the ox respectively; the cat the *T. crassicolis* from the mouse; and so on. Second, the *matacolepidota*, or soft-shelled tapeworms, the eggs of which are to be hatched in the stomach of articulata and mollusks. The mature entozoa of this order inhabit the intestinal canal of such animals as prey upon the above, as fish, birds, and insectivorous mammalia.—*Trematoda, stercorintha* (Owen), isolated flat worms. These entozoa are characterized by their flattened, more or less elongated shape, and by ventral sucking disks. The same individual possesses the organs of both sexes. Rudolphi divided them into different genera, according to the number of cup-like suckers present. This classification has been given up, inasmuch as the more important distinctions of structure did not correspond to the external markings;

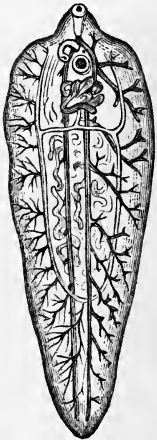

Fig. 7.—*Distoma hepaticum*.

but many of the names have been retained. Thus the *distoma hepaticum*, or liver fluke, has two sucking disks. This, the best known of the trematode worms, resembles much a cucumber seed in form, and measures in length one inch, in width about half an inch. It is yellowish brown, probably owing to the bile in which it lives. In this class we first find evidence of an alimentary canal, in addition to the sexual organs, which gives it a higher rank than the *cestoidea*. This consists of a triangular opening or mouth, which may be used either as a sucker or means of obtaining nutriment. From this rises the intestinal canal.

An excretory system is also present. This fluke has been found only in a few well authenticated cases in man. Its true home is in the gall ducts of sheep, and it is generally found in the same place in the human system. Cases are on record in which it has been found beneath the skin, having made its way thither by boring into the epidermis. In the liver of the lower animals it works sad havoc in autumn and winter, causing a dilatation and catarrh of the gall ducts, and an interference with the hepatic function, by which, of course, the secretion of the bile is disturbed and changed. They may occur in such quantities as to stop up the cystic duct, and their eggs are deposited in vast numbers in the bile. The symptoms they create in man need not be stated here. The passage of this worm by the stomach or intestines is the only proof we could have of its presence before death. The generation and development

of these worms had been a subject of great interest to naturalists, since Steenstrup made them the object of investigation in illustrating his theory of alternation of generation. The eggs of the *distoma*, escaping in the form of ciliated embryos, become converted while in the water into nurses or grand-nurses; that is to say, they are not themselves developed into young distomata, but produce in their interior several new organisms, which latter are the real young or larvæ of the future animal. These nurses are supplied with organs of self-support. The young brood, known as *cercariae*, possess in some species tails by which they undertake wanderings on their own account, become attached to mollusks or like animals, and thus find their way into the intestine and liver of some larger animal. The tailless brood have the power of encysting themselves while in the water, and may thus be borne about till they are swallowed by some of the herbivora. This is the general plan of development in all trematode worms, but it is not yet known what peculiar metamorphoses this entozoön undergoes. There can be little doubt, however, that sheep infect themselves by devouring snails which frequent the grass in moist meadow pastures, or by drinking ditch water. Whether "the rot" is actually caused by this parasite is not absolutely certain, though highly probable, as they are always found in this disease. Little benefit is to be derived from the use of anthelmintics, but a proper attention to these laws of prophylaxis will aid the farmer much in preserving his flocks in a healthy condition. The *distoma hæmatobium* forms a very common disease in man in Africa, according to Bilharz, who found it first in the blood of the portal and mesenteric veins. But its chief habitation is the bladder and intestines, and when present in numbers it is very detrimental. In the bladder the worms fasten themselves to the mucous membrane, and produce patches of inflammation, exudation, and hæmorrhage. The fungous excrescences thus caused are pedunculated, and often of the size of a pea. Within them the animals may be found, and on their external surface the eggs. In the ureters the inflammation they create is sufficient to pro-



Fig. 8.—Ciliated Embryo of *Distoma*.



Fig. 9.—*Cercaria* of *Distoma hepaticum*.

duce pedunculated, and often of the size of a pea. Within them the animals may be found, and on their external surface the eggs. In the ureters the inflammation they create is sufficient to pro-

duce stricture, and consequent atrophy of the kidney. Several other species of trematode entozoa have been found both in man and herbivorous animals. Some of them infest the eyes of animals, and are sometimes found in such prodigious quantities as almost to fill the cavity of the eyeball.—*Acanthocephala*, *sterelemintha*, hooked worms. This group of entozoa, which resembles the *nematoidea* in form and distinction of sex, approaches more nearly the *trematoda* in its digestive system. It includes some of the most noxious of the parasitic helminths, but none infest man. They are included under one genus, *echinorhynchus*, which is characterized by its retractile proboscis, armed with recurved spines. It is found in the intestines of the hog and other animals.—*Nematoidea*, *caelemintha* (Owen), or round worms. This class is made up of the round worms which inhabit the intestine, lungs, and kidneys of man and the lower animals, or else are enclosed within cysts in the muscular system or beneath the epidermis. They too undertake migrations and undergo transformations, but we are less acquainted with their development than with that of the first two classes; all that we know of them is, that we find sexually mature and embryonic forms, but to trace a connection between them, or to discover their mode of growth, has hitherto been possible only in a few species. They are distinguished from the *cestoidea* and *trematoda* by a more elaborate digestive apparatus, by a nervous system, and by individuality of sex. Most of the species are oviparous, and the development of their eggs has been lately made the study of helminthologists. The ova are enclosed in hard shells, within which under suitable conditions the embryo is further developed by segmentation, till it breaks from its habitation, and comes forth either a perfect worm, or in an intermediate form, in which it wanders into the tissues of man and other animals, where it may undergo the encysted stage, and finally on escaping become the mature individual, when it has found again a suitable habitation. The largest of this class is the *strongylus gigas*, which belongs to the dog and other animals, but which has been found at rare intervals in the human kidney. It is a long, cylindrical, red monster, with a mouth made up of six papillæ. The male, as usual in the *nematoidea*, is the smaller, measuring from 10 to 12 in., while the female sometimes attains the length of 3 ft., and is half an inch in thickness. This sea serpent of the human entozoa seems really to cause very little trouble. Like the *ascaris*, its relative, its fine red color seems owing to a reddish oil secreted by the vacuoles of the skin. Another species, *S. equinus*, is very common in the intestine of the horse, and *S. longivaginitus* has been found in the lungs and bronchial glands of man. The *ascarides* are very numerous, and inhabit the intestines of many animals. The *ascaris lumbricoides* is the largest which infests the human intestine. It is found all over the world, and

prefers the lower part of the small intestine. It is of a pale, pinkish hue, cylindrical and elastic, has pointed extremities, and varies greatly in size according to age and sex. The male measures from 4 to 6, the female from 8 to 18 in. in length. The head is trilobulate with a constriction below the papillæ, which serve as sucking surfaces. The intestinal canal is a straight tube piercing the centre of the worm from end to end. They are very prolific, and as many as 64,000,000 ova have been found in one female. These eggs when immature are triangular and very irregular in shape, but when impregnated are enclosed in oval shells, within which the process of segmentation is carried on. Whether it is their nature first to go through a developmental stage outside of man, and to gain readmission in food or in drink, is not known. Their great number, sometimes 300 or 400 together, leads to the belief that they may under favorable circumstances reproduce themselves in the original host. Any opening between the intestine and any cavity of the body may prove a loophole for its passage, and in this way its presence in strange places, as the bladder or abdominal cavity, may be accounted for. At all events, it is impossible for it to make an opening through the intestine or any tissue of the body, for it is without the means of doing so.

The presence of *ascarides* has been attributed to illness and bad food and bread. They are most abundant in moist localities, as seacoasts and river valleys, and they may gain admission to the intestines on raw fruit, or in mollusca and larvæ of insects, which abound in such places. Bad food or the want of food will undoubtedly cause their discharge, as well as illness, but only because they are starved out, and because bad food and sickness generate an unhealthy action in the intestine, which thus becomes disagreeable to them. So their discharge is more frequent in summer, but it is on account of the frequent diarrhœas which follow the eating of green fruits and vegetables, by which they be-

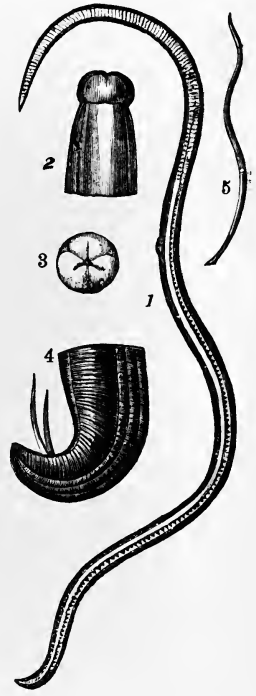

FIG. 10.—*Ascaris lumbricoides*. 1. Female. 2. Head. 3. Front view of head, showing the trilobulate form. 4. Tail. 5. Male.

come sickly and are expelled, and not because they are generated by such food of itself; for it must take a long time for them to reach maturity, and they are seldom seen before this age. All attempts to produce these worms in the lower animals by administering eggs have thus far failed. The *oxyuris* or *ascaris vermicularis*, the thread or pin worm of the rectum, is the smallest of the human intestinal worms, the male being about two lines and the female five lines long.



FIG. 11.—*Oxyuris vermicularis* (female).  
1. Natural size.  
2. Magnified.



FIG. 12.—*Trichina spiralis*.

Its structure resembles that of its larger relative, and its head is also three-lobed, faintly marked.—The muscles of man are sometimes found after death to present a sanded appearance, which is caused by the presence of innumerable little cysts scattered throughout their substance; these are generally isolated, but in immediate contiguity. These minute bodies when examined microscopically are found to contain immature worms coiled up in the narrowest compass. They are cylindrical and tapering,  $\frac{1}{25}$  of an inch long by  $\frac{1}{100}$  of an inch thick, and their name is *trichina spiralis*. Both in the hog and in the human subject they are sometimes found in great abundance in the muscular tissue, sometimes as many as 70,000 or 80,000 to the cubic inch. When first discovered in 1832, and for many years afterward, they were supposed to be harmless, no symp-

tom connected with their presence having been detected. It is now known that in the cases first observed the parasites had long lain quiescent in the muscular tissue, and that their recent introduction into the system forms one of the most dangerous affections to which the human race is liable. The true physiological history of *trichina spiralis* is as follows: When the muscular flesh of pork containing the encysted parasite is eaten in an uncooked or imperfectly cooked condition, the cysts are digested and destroyed in the stomach, but the worms themselves, retaining their vitality, pass into the small intestine. In this situation they lose their spiral form, and begin to increase in size; and by the fourth or fifth day they arrive at maturity, attaining a length of from  $\frac{1}{5}$  to  $\frac{1}{4}$  of an inch. At the same time the sexual organs are fully developed, copulation takes place, and the females become filled with mature eggs and embryos, which last are produced alive and in great abundance. These embryos, which are of minute size but in form similar to their parents, then begin to penetrate the walls of the intestine and to dispose themselves over the body. This causes at first an irritation of the intestine, which is usually the earliest symptom of the attack. Within a fortnight after the commencement of the symptoms the embryos are usually to be found scattered throughout the body and limbs, in the tissue of the voluntary muscles. They are still not more than  $\frac{1}{10}$  or  $\frac{1}{20}$  of an inch long. They soon become enclosed in distinct cysts, where they grow to the size of  $\frac{1}{25}$  of an inch, and at the same time become coiled up in the spiral form. This period of the invasion of the muscular tissue by the parasite is one of great danger to the patient, being characterized by swelling and tenderness of the limbs, pain on motion, and general fever of a typhoid character. The attack is often fatal about the fourth week. If the patient survive that period, the trichinae become quiescent, cease their growth, and may remain without further development or alteration for an indefinite period. The only protection from danger of being infected with trichina from eating pork is to be sure that the meat is always thoroughly cooked throughout.—*Tricocephalus dispar* (fig. 13) is a nematoid worm which is found, rather rarely and in small numbers, in the cavity of the human caecum, and exceptionally in the colon or in the small intestine. Its anterior or cephalic extremity is slender and filamentous, while its posterior portion is thicker and more robust. The male, when extended, is about  $1\frac{1}{2}$  in. long; the female  $1\frac{1}{2}$  to 2 in. The eggs are ovoid in form,  $\frac{1}{100}$  of an inch in length, and marked at each extremity by a minute nipple-like projection. They are discharged into the cavity of the intestine, and the embryo is developed only after a considerable time. This worm is not known to give rise to any disagreeable symptoms.—One more of the human entozoa is sufficiently interesting to be mentioned here at length, viz.: the

*filaria medinensis*, or Guinea thread worm. This is confined to certain localities in the tropical regions. It is seldom over 9 ft. long, and is found of all lesser sizes according to its age. The male has not yet been described, for either its small size prevents detection, or else it never occurs in man. In shape the female resembles a flattened cord, one line in diameter. Its color is pale yellow, and it is viviparous. Its head is circular and armed with four straight pointed spines, by which it probably penetrates the tissues. It inhabits the subcutaneous areolar tissue, and chiefly that of the ankles, feet, and legs; but it has also been found in the abdominal parietes and arms. It often proves an endemic, attacking certain regiments in armies and sparing others. It appears to follow the rainy seasons, and to occur mostly in low and marshy districts. There can be hardly any doubt that this animal is an inhabitant of wet places, and that man infects himself only by allowing it to come in contact with his skin. Those who take great precaution against wetting their feet, sleeping on the ground, and bathing in marshy pools, generally escape it. The worm may lie coiled up or extended at full length beneath the skin. As many as 50 individuals have been observed in one person, but usually one alone occurs. If superficial, its growth may be watched from day to day, and it has been seen to increase more than an inch in 24 hours. It often lies concealed for a long time without causing any symptoms of its presence, and may thus be borne from one country to another. When about to open externally, a little boil is found on the skin, which either bursts or is opened, and the anterior end of the worm protrudes. It is removed by seizing this and making gentle traction. All that readily yields is wound about a compress, and bound down over the wound till the following day, when the process is repeated

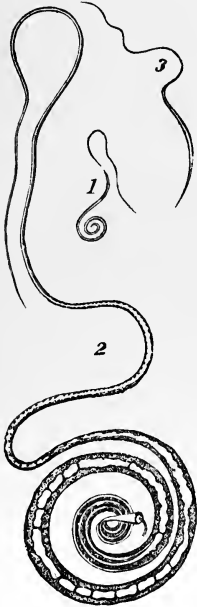

FIG. 13.—*Tricocephalus dispar*.

1. Male, natural size.
2. Male, magnified.
3. Female, natural size.

till it is wholly extracted. Great care is taken not to break the worm, for serious results often follow such accidents. It is probable that the young or germs inhabit wet soils, and enter the tissues of other animals to attain their full development after being impregnated outside. The attempt of the mature female finally to escape seems to imply that, its end be-

ing accomplished, it would return to its former home, and deposit its young, where new hosts may offer themselves for their reception.— Many other less important varieties of these three classes of entozoa have been described.—*Medical Treatment.* The administration of drugs in the encysted stages of tapeworm would of course be useless, and their diagnosis is often a most difficult problem. The following remarks apply then only to the intestinal forms. Nothing should be done until the passage of joints gives the infallible sign of the presence of the worm. All statements of patients regarding their own symptoms must be received with much doubt. A long catalogue of fearful and frightful ills is ascribed to their presence, but probably in the majority of cases without any cause whatever. It is true that the worm feeds upon the nutriment of the patient, but this has not yet formed a part of his organization, and is not assimilated. Whether epilepsy is ever caused by tapeworm is a matter of great doubt, and more valid proof is needed to show more than a coincidence between the presence of the two. Some species cling more firmly than others, and are more difficult to dislodge. Of course, unless we obtain the head we fail, for the *scotex* may go on producing new colonies indefinitely. The only way to effect their removal is to render their habitation disagreeable to them. Various drugs (called anthelmintics) are employed to drive out these intruders. A brisk cathartic may dislodge one or two ascarides if present, or bring away a piece of tapeworm. Cowhage (*maecuna pruriens*) and tin filings are now seldom used. Santonine, the active principle of *santonica* or *semen contra*, is used in doses of 3 to 6 grains three times a day. The oil of wormseed (*chenopodium*) is used in doses of 5 to 10 drops. Spigelia or pinkroot, alone or with senna, is a favorite anthelmintic in the United States, and the bark of the pride of China (*melia azedarach*) in the south. Tansy and wormwood, though not frequently used, may be added to the list. The small worms in the rectum are best treated with injections, either of ice water, salt water, infusion of quassia, lime water, or decoction of aloes. The tapeworm is advantageously attacked with oil of turpentine, petroleum, the oleo-resin of male fern (*aspidium filix-mas*), pomegranate bark, kameela (from *Rottlera tinctoria*), or by koussou, the flower of *Brayera anthelmintica*. An emulsion prepared from the seeds of the common pumpkin has been used with very good effect, and has the merit of causing no disagreeable symptoms. Some of these drugs, as male fern, santonine, pomegranate, and koussou, produce more or less intestinal disturbance; and some, as santonine, pomegranate, spigelia, and azedarach, produce nervous symptoms. Benzine and picric acid have been suggested for destroying the *trichina spiralis*; but unfortunately the presence of this dangerous parasite is not likely to be recognized



while accessible in the intestine, except during an epidemic, and it is not probable that any drug has power to dislodge or affect him after he has made his way into the tissues. It is said that the disease of sheep called rot, which is accompanied by the presence of these parasites in the biliary passages, does not occur where the bog bean (*menyanthes trifoliata*) or tomentil grows, no matter how damp the pastures may be; nor are the sheep which feed in salt marshes or have salt mixed with their food subject to rot. No remedies as yet discovered are of any avail in the treatment of the *trematoda*, and their presence can only be correctly diagnosed when their passage into the outer world is observed. Among the *nematoidea*, the *oxyurides*, or pin worms, are the most troublesome, on account of the intolerable itching caused by their nightly wanderings outside the intestine. No treatment can wholly remove them, but cathartics and cold enemata are the best remedies.—The bibliography of helminthology has received many valuable additions within a few years, since it has become a distinct science. For a more complete account of its progress the following books may be referred to: Rudolphi, *Entozoorum sive Vermium Intestinalium Historia Naturalis* (3 vols. 8vo, Amsterdam, 1808); Steenstrup, publications of Ray society, "Alternation of Generation" (London, 1845); Bremsler, *Ueber lebende Würmer im lebenden Menschen* (4to, Vienna, 1819); Diesing, *Systema Helminthum* (2 vols. 8vo, Vienna, 1850); Dujardin, *Histoire naturelle des helminthes ou vers intestinaux* (Paris, 1844); Van Beneden, *Vers cestoides ou acotyles* (4to, Brussels, 1850); Leuckart, *Blasenbandwürmer und ihre Entwicklung* (4to, Giessen, 1856); Owen, "Lectures on Invertebrata" (8vo, London, 1843); Küchenmeister and Von Siebold, translated in Sydenham society publications (2 vols. 8vo, London, 1857); Leidy, "A Flora and Fauna within Living Animals" (Smithsonian publications, vol. v., 4to, Washington, 1853); Weinland "Human Cestoides" (8vo, Cambridge, 1858); Davaine, *Traité des entozoaires* (Paris, 1860); Leuckart, *Untersuchungen über Trichina spiralis* (Leipsic, 1860); Cobbold, "Entozoa" (London, 1864); and Pagenstecher, *Die Trichinen* (Leipsic, 1865).

**ENTRAGUES, Catherine Henriette de Balzac d'**, marchioness de Verneuil, a mistress of Henry IV., born in Orleans in 1579, died in Paris, Feb. 9, 1633. She was a daughter of François de Balzac d'Entragues by his second marriage with Marie Touchet, a former mistress of Charles IX. After the death of Gabrielle d'Estrées (1599) she became the mistress of Henry IV., who presented her with 500,000 francs and signed a contract to marry her in the event of her bearing him a son, which he renewed Oct. 1, 1599, after having cancelled it at the instance of his minister Sully. But her miscarriage in July, 1600, prompted him to marry Marie de' Medici. He compensated

his mistress by making her marchioness de Verneuil; but she insisted upon remaining in the Louvre, making herself obnoxious to the king, and especially to the queen. She long declined to give up his written pledge to marry her, but finally returned it in July, 1604, in consideration of the payment of 100,000 francs. But instead of carrying out her promise of going to England, she remained in France conspiring against the king, involving in her scheme her father and her half brother, the count d'Auvergne, who were sentenced to death Feb. 1, 1605, but pardoned through her continued influence over Henry IV. She was herself almost immediately released from prison, and it was even asserted that the king again took her for a short period as his mistress, until she was supplanted by a new rival. The testimony of a maid of honor of the queen implicated her in 1610 in the assassination of the king; but this lady (Mlle. de Coman) was imprisoned for life for perjury, while the marchioness spent her remaining years in affluence on her estates. She bore two children to Henry IV., who were both legitimated: Gabrielle Angélique, who married the duke d'Épernon, and died in 1627; and Gaston Henri de Verneuil, born in 1601, who was nominated bishop of Metz while still a layman, but never received episcopal consecration, was created a duke and peer, married a daughter of Chancellor Séguier, and died in 1682.—See De Lescuré, *Les amours d'Henri IV.* (Paris, 1863).

**ENTRECASTEAUX, Joseph Antoine Bruni d'**, a French navigator, born in Aix in 1739, died at sea near the island of Waigeo, in the Pacific ocean, N. of Papua, July 20, 1793. He entered the naval service in 1754, gradually rose to the position of commandant of the French fleet in the East Indies (1785), and in 1787 became governor of Mauritius and the Isle of Bourbon. In 1791 he was sent by the French government in search of La Pérouse, who had not been heard from since February, 1788. He failed to detect any trace of him, but ascertained with great exactness the outlines of the E. coast of New Caledonia, the W. and S. W. coast of New Holland, Tasmania, and various other coasts. Accounts of his voyages have been published by De la Billardiére (2 vols., Paris, 1800), De Rossel (2 vols., 1808), and De Frémenville (Brest, 1838).

**ENTRE DOURO E MINHO.** See MINHO.

**ENTRE-RIOS**, a province of the Argentine Republic, bordered E., S., and W. by the rivers Paraná and Uruguay, whence its name (between rivers). It is bounded N. by Corrientes, E. by the republic of Uruguay, S. by Buenos Ayres, and W. by Santa Fé; area, about 30,000 sq. m., although a late but inaccurate official statement makes it 50,000; pop. in 1859, 87,500; in 1869, 134,271, including about 18,000 foreigners. The increase was largely due to the Paraguayan war and to political disturbances in neighboring provinces. The country is intersected

by a series of hills, none of which attain a greater elevation than 300 ft.; but toward the N. W. rises Mount Montial, with a surface equal to about one fifth of that of the whole territory. Extensive forests cover the plains, especially along the banks of the rivers, which latter are exceedingly numerous, and not a few of considerable magnitude. The climate is in general mild and equable, and is considered by Europeans to be very salubrious. Entre-Rios is essentially a pastoral province; over 8,000 of its inhabitants are *estancieros* or cattle farmers, with immense herds of horned cattle, sheep, horses, and swine. Wheat, maize, mandioca, sugar cane, peanuts, tobacco, and many kinds of fruit are produced in abundance. Cotton, until 1865 extensively cultivated, has since that time received but little attention, owing to periodical droughts, and the lack of hands to pick it. Cochineal, indigo, and cascarilla yield large crops spontaneously; and the silkworm has been introduced. The forests supply a great variety of valuable timber. Fine limestone abounds in many parts, and extensive quarries are worked along the margin of the Paraná; a kind of cement is found in several localities, and exported to Buenos Ayres. Other important exports are hides, horns, tallow, jerked beef, dairy produce, eggs, honey, and wax. Occasional inundations and the want of adequate roads are great drawbacks to the prosperity of the province. There are 78 primary schools, 25 public and 53 private; and these were attended in 1871-'2 by 3,691 children between the ages of 6 and 15 years, out of a total number of 36,840 children. The province is divided into departments, and these into *distritos de campaña*. Capital, Concepcion del Uruguay.

**ENVERMEU**, a small town of France, in the department of Seine-Inférieure, Normandy; pop. about 1,500. It is within a few miles of Dieppe, and contains the site of an ancient Frankish cemetery, explored from 1849 to 1856 by the abbé Cochet, and found to contain many valuable relics, among them bronze and gold jewelry, swords, sabres, bronze buckles, a Gaulish coin or rather ingot of gold, which presented on the reverse an ill-formed miniature horse (supposed to belong to the era of 270 to 100 B. C.), necklaces of glass beads, iron axes (*francisca*), accompanied by iron lances (*frameæ*), iron spurs, arrow points, iron daggers ornamented at the point with a plate of bronze and flanked by small knives, elegant bronze purse clasps, &c. The cemetery seems to have been circular, and was probably once covered by a tumulus, long since removed by the operations of agriculture.

**ENZIO**, or **Entius**, a natural son of Frederick II., emperor of Germany, born in 1224 or 1225, died in Bologna, March 14 or 15, 1272. He was handsome, accomplished, and chivalric, and took a distinguished part in the contests of his father with the Guelphs. At the

age of thirteen he accompanied him to the battle of Cortenuova, and about two years later his father caused his marriage with Adelasia, marchioness of Massa, the widow of Waldo-Visconti, and the heiress of important possessions in Italy. On this occasion he was created king of Sardinia, but it was only a nominal dignity. A more substantial one conferred on him by the emperor was that of governor general of Lombardy and commander of the German troops against the Milanese. Gregory IX. excommunicated Frederick in March, 1239; the pope's anger increased the ardor of Enzo, and he conquered for his father many towns in Umbria. As commander of the emperor's naval force in 1241, he defeated, in conjunction with the Pisan fleet, the Genoese in the vicinity of Leghorn, near the island of Meloria (May 3), after a protracted engagement. A great number of prelates were on board the Genoese galleys, about to attend, in spite of the emperor's remonstrance, a council convoked at Rome by Gregory. All these prelates, about 100 archbishops and bishops and three legates of the pope, were captured; the total number of prisoners was estimated at 4,000. The booty taken from the Genoese comprised a large amount of money, and in token of this success the prelates were removed to prison in chains of silver. After this and other victories over the Guelphs, the Ghibelines were defeated, May, 26, 1249, in the bloody battle on the Fossalta. Enzo being captured, the Bolognese condemned him to perpetual imprisonment, and refused to release him, although the emperor was ready to pay any ransom. He continued in prison 23 years, surviving the sons and grandsons of Frederick, who all met with violent deaths.

**EOCENE** (Gr. *ἠώς*, dawn, and *καινός*, recent), the lowest division or earliest epoch of the tertiary formation or period. It was named by Sir Charles Lyell, who divided the tertiary period into three epochs, called respectively, according to time, eocene, miocene, and pliocene, under the generally existing belief that the eocene contained among its fossils from 5 to 10 per cent. belonging to existing species. It was known that the next older formation, the cretaceous, belonging to the reptilian age, contains no existing species, and therefore this lowest tertiary epoch was named for the purpose of expressing the idea that it was the dawn of the existing state of the testaceous fauna. Since the division was made and brought into general use, it has been found that all the species of the eocene epoch are extinct. The miocene, however, contains from 10 to 40 per cent. and the pliocene from 50 to 90 per cent. of species now existing. The eocene rocks are well developed in the London and Paris basins, the cities of London, Paris, and Brussels being built upon the formation; a circumstance which has tended to attract much attention to its study, as well as the numerous fossils which it contains, and by which it was

subdivided into lower, middle, and upper eocene, called also in the United States the Claiborne, Jackson, and Vicksburg epochs. It extends along a great portion of the S. E. coast of the United States, principally in Maryland, Virginia, the Carolinas, and the gulf states. The beds reach their most complete and distinct development in Mississippi and Alabama. Those of the Claiborne epoch or lower eocene, near Claiborne, Ala., consist of about 25 ft. of clay overlaid by a bed of lignite 4 ft. thick, and succeeding this marl with oysters, then marly arenaceous limestone, again succeeded by marl with oysters, upon which is sand with shells showing beach origin, the whole being about 125 ft. thick. In Mississippi the beds reach a thickness of 425 ft. The epoch is represented on the Pamunkey river in Virginia, and at Marlborough in Maryland, by dark greensands. In the upper Missouri there is a great lignite group 2,000 ft. thick, containing much lignite, numerous leaves of plants, and shells of mollusks; and a lignite formation also occurs in Texas. The beds of the Jackson epoch, or middle eocene, are represented at Jackson, Miss., and consist of lignitic clay and beds of white and blue marls, containing numerous marine shells, and remains of the *zeuglodon*, and extinct species of whale supposed to have been about 70 ft. long, whose large vertebrae, 18 in. long by 1 ft. in diameter, are found in such quantities in some places as to be used in making walls. The Jackson beds cross the state as a narrow band about 80 ft. thick, E. N. E. through Jackson and Scott counties. The beds of the Vicksburg epoch, or upper eocene, are represented at Vicksburg, Miss., and consist of: 1, lignitic clay, 20 ft. thick; 2, ferruginous rock of Red Bluff, containing numerous marine fossils, 12 ft. thick; 3, compact limestones and blue marls, with marine fossils, 80 ft. thick; making a total thickness of 112 ft. The Vicksburg group occurs in Munroe, Clarke, and Washington counties, Ala.; as limestone at Tampa Bay, Fla.; and as gray marl on Ashley and Cooper rivers, S. C. In the upper Missouri region there are freshwater beds 1,000 ft. thick, consisting of white and drab clays, layers of sandstone, and local beds of limestone; but they are considered by Leidy as miocene. In them are found the remains of the *titanotherium*, an herbivorous animal, somewhat resembling the modern tapir, and about twice the size of a horse.

**ÉON DE BEAUMONT, Charles Geneviève Louis Auguste André Timothée d'**, commonly called the chevalier d'Éon, a French diplomatist, who owes his notoriety to doubts which long existed as to his sex, born in Tonnerre, Burgundy, Oct. 5, 1728, died in London, May 21, 1810. He was of good family, was well educated, became a doctor of canon and civil law, and an advocate before the parliament of Paris, and at the outset of his career applied himself with some success to literature. In 1755 Louis XV. employed him in a delicate diplomatic mission to

Russia in company with the chevalier Douglas. Favored by a beardless face, he assumed the dress of a woman, and, blending a woman's tact with a politician's cunning, gained the good graces of the empress Elizabeth, became her reader, and having bent her mind to the wishes of the French court, went back to Paris to announce his success. He immediately revisited St. Petersburg in male attire, passed himself upon Elizabeth as the brother of her former favorite, was again successful in his negotiations, and on his way back to France appeared as envoy at Vienna. Having held a commission in the army, he was promoted to a captaincy of dragoons in 1759, served with the forces on the Rhine, and acted as aide-de-camp to Marshal de Broglie during the latter campaigns of the seven years' war. He was then secretary of embassy, and afterward minister plenipotentiary, at London; but being superseded in 1763 by the count de Guerchy, and mortified by being named secretary to his successor, he published a complete account of all the negotiations in which he had been engaged, exposed many secrets of the French court, and reflected with equal severity upon friends and enemies. Among the victims of his slander was De Guerchy, who brought an action in the court of king's bench, in which D'Éon was convicted of libel in July, 1764, and was finally outlawed. He continued, however, to reside in England, subsisting for a time by borrowing and various expedients, and afterward on a pension which Louis XV. allowed him for secret services; and after the return of De Guerchy to France, he acted as the representative of the court of Versailles, though not officially recognized as such. About 1763 rumors respecting his sex, which received color from his adventure in St. Petersburg, his appearance, his manners, and the reports spread by De Guerchy, became common topics of conversation in the British capital; bets to a large amount were laid that he was a woman, and a wager of this sort became matter for a lawsuit, in which the plaintiff, having brought witnesses to swear that D'Éon was a female, obtained a verdict for £700. In 1777 he went to Versailles, where Louis XVI., for reasons which have never been made known, forced him to adopt a woman's dress. He returned to England in this garb in 1783, and supported himself in London by the sale of his library, by giving exhibitions of his skill in fencing with the famous M. St. George and Mr. Angelo, and by a pension from George III. On the outbreak of the revolution he offered his services in a military capacity; but they were declined, and he passed the rest of his days in poverty in England, retaining till his death the garb which had been forced upon him 33 years before. A post mortem examination left no doubt of his being a man. He wrote a number of historical, political, and other works. The *Mémoires* attributed to him are spurious.

**EOS.** See AURORA.

**EÖTVÖS, József**, baron, a Hungarian author and statesman, born in Buda, Sept. 3, 1813, died in Pesth, Feb. 2, 1871. His education was completed at the university of Pesth, and at the age of 17 he commenced his literary career by a translation of Goethe's *Goetz von Berlichingen*. This was followed by two original comedies and a tragedy. In 1836 he travelled through Germany, Switzerland, France, and Great Britain. In 1838 he became the editor of the *Budapesti árvizkönyv*, a work in which the most eminent Hungarian men of letters took a part. He contributed to it a novel entitled "The Carthusian," which made him at once the favorite of the Hungarian public. A pamphlet issued by him on prison reform produced a deep impression. His eloquent defence of the "Emancipation of the Jews" was still more remarkable. In the great controversy about Kossuth's *Pesti Hírlap*, Eötvös espoused his cause, and published a pamphlet in 1841 defending him against the conservative leader Széchenyi. As one of the leaders of the opposition in the upper house of the Hungarian diet, Eötvös achieved a distinguished position. But whatever may have been his merit as an orator and a politician, it was eclipsed by his fame as a novelist. His novel *A falu jegyzője* ("The Village Notary," 3 vols., 1844-'6), in which he boldly exposed the abuses connected with the rule of the nobles in the counties, had a marvellous success, and was translated into German and English. In 1847 he produced a new novel on the revolt of the peasantry in 1514, entitled *Magyarország 1514-ben* ("Hungary in 1514"). During this time he also exerted great influence through the newspaper press. His articles in the *Pesti Hírlap*, now edited by his friend Szalay, especially on centralization, of which he became the champion, while Kossuth defended the autonomy of the counties, were collected in 1846 in a volume at Leipzig under the title of "Reform." After the outbreak of 1848 Eötvös was appointed minister of worship and public instruction under the Batthyányi administration. He brought forward a comprehensive measure for the improvement of education, which was strenuously opposed on sectarian grounds, but was warmly supported by Kossuth and adopted by the diet. Eötvös, however, withdrew from the cabinet on the assassination of Count Lamberg, and retired to Munich, but returned to his native country in 1851. During the period of the suspension of the Hungarian constitution he published his work on "The Influence of the Leading Ideas of the 19th Century on the State" (2 vols., 1851 and 1854, Hungarian and German by the author), and several political pamphlets. In 1856 he was elected vice president and in 1866 president of the Hungarian academy. In 1861 he became a member of the lower house of the Hungarian diet as representative of the city of Buda, from which time he actively coöperated with Deák for the restoration of the consti-

tution; and on the creation of the Andrassy cabinet in 1867 he entered it as minister of worship and education. This office he held till his death.

**EOZOÖN** (Gr. *ἠώς*, dawn, and *ζῶον*, animal), a name given to certain forms found in the Laurentian rocks of Canada, Massachusetts, and other primordial regions, under the belief that they are the impressions of the earliest animal organisms which appeared on the earth. The serpentine rock in which they are found is far older than the lower Silurian, in the azoic series of authors; if these are of organic origin, they carry back the first appearance of animal life to a period much earlier than geologists have usually admitted. Dr. Carpenter, Dr. Dawson, and others regard the so-called *ezoöon Canadense* as a protozoan, of the rhizopod or foraminiferous division, a jelly-like living mass, spreading over the bottom of the sea, secreting calcareous partitions, and thus forming small chambers or cells, the interior of which has been filled with serpentine deposited from the waters of the ocean. Dr. Dawson believes that it had several foraminiferal successors in these early periods. On the other hand, excellent microscopists and mineralogists deny its animal origin, and maintain that these are only imitative forms of inorganic material, the result of infiltration of waters and chemical agency. Specimens have been found in the limestone or serpentine of Newbury and Chelmsford, Mass., in semi-crystalline vein-like deposits in granitic gneiss, in isolated masses, and not in stratified deposits accessible to fossils. High authorities are enlisted on each side, but the evidence seems to preponderate on the side of its animal origin.—The term *eophyton* has in like manner been applied to what appear like the remains of a terrestrial flora found in Swedish rocks of eozoöal age; they seem like stems and long parallel-veined leaves of monocotyledonous plants allied to the present rushes; they apparently grew on the margin of shallow waters, where they were buried in sand or silt. The *E. Linnæanum* of authors probably contains several species. This may also be a dendritic or imitative form, of inorganic material. It stands by the side of eozoön; the one being, in the present state of our knowledge, perhaps the earliest land plant, the other the earliest animal organism.

**EPACT** (Gr. *ἐπακτός*, added, inserted, excessive), a word formerly employed to denote the difference in time obtained by comparing any two periods, as the 11 days by which the solar exceeds the lunar year. Now it denotes generally the number of days between the last new moon and the first day of the next year. These epacts are counted in Roman figures from I. to XXVIII. When a new moon falls on the first of January, then the epact is 0, that of the next year XI., and that of the third XXII. But in continuing this calculation, 30 is subtracted from every number exceeding 30. The epact for the fourth year is therefore reduced

to III. ; then for the following two years 11 is added again, and from the sum obtained for the 7th year, being greater than 30, that number is again subtracted. Every 19th year the epact is XXVIII., after which the series is repeated. The epact does not give the exact age of the moon. In the Julian calendar the correction of the error in the lunar cycle is made at the end of 300 years; in the Gregorian calendar this error is assumed to amount to one day in 312½ years. The epacts are used to determine Easter Sunday, on which the dates of all the other changeable feasts of the church depend.

**EPAMINONDAS**, a Theban statesman and general, born about 418 B. C., died on the battle field of Mantinea in 362. He was the son of Polymnis, a Theban who, though poor, was a member of one of the noble families. In his youth he was an earnest student of philosophy, and, while receiving an exceptional education in all respects, devoted himself especially to this study under the tutorship of the Pythagorean Lysis, to whose influence his contemporaries attributed many of his best characteristics. With Pelopidas, a man of congenial virtue, he was early connected by the ties of tried friendship, though the date of the battle in which he saved the life of his friend cannot be fixed. When the Spartans gained possession of the Theban citadel, the Cadmea, in 382, Epaminondas for a time refused to join in the plan for its recapture, through fear of useless bloodshed, to which the teachings of his philosophy made him particularly averse; but when the first decisive step had been taken, Archias and Leontiades, the Spartan tyrants, had been killed, and the affair had assumed the aspect of a revolution rather than a conspiracy, he at once came forward as a leader, and was among the foremost in the attack which induced the Spartan surrender (379). In 371 he acted as the ambassador for Thebes when the envoys from all parts of Greece came together at Sparta to negotiate treaties. Here he greatly distinguished himself by his eloquence in advocating against Agesilaus of Sparta the claim of Thebes to represent all Bœotia. This was disallowed by the assembled envoys. Thebes was excluded from the treaty altogether, and war between Thebes and Sparta was at once declared. Less than a month afterward the armies met at Leuctra, the Spartans being under the command of Cleombrotus. The Thebans, commanded by Epaminondas, assisted by Pelopidas, gave battle at once, by the advice of the former, and after a brief struggle won a complete victory. The triumph of the Thebans was clearly due to the new tactics invented by Epaminondas. The results of the victory were further secured by the union of Arcadia and the founding of Megalopolis; these measures, suggested by Lycomedes, but vigorously urged and in great part carried out by Epaminondas, at once opposed a strong obstacle to any further schemes of Spartan dominion.

This accomplished, Epaminondas and Pelopidas invaded the Peloponnesus (369), ravaged Laconia, freed Messenia from the Spartan yoke, founding a new capital for it on the site of the ancient Ithome, and appeared before Sparta, which escaped capture through the wise provisions of Agesilaus. To continue these conquests both Epaminondas and Pelopidas had retained their commands longer than the Theban law allowed; and on their return they were tried for this, but both were acquitted, with the enthusiastic approval of the people. In 368 Epaminondas again invaded the Peloponnesus, compelled Sicyon and Pellene to abandon their alliance with Sparta, and made an unsuccessful attack on Corinth. He returned home, it appears, without having pushed his advantage sufficiently to satisfy the Thebans; and this is given as the reason for his receiving no command in the expedition sent into Thessaly the same year to rescue Pelopidas from Alexander of Pheræ, into whose hands he had fallen. This undertaking failed, and the historians attribute the saving of the army from utter ruin to the efforts of Epaminondas. A year later he led a force organized for the same purpose, and this time achieved the delivery of his friend, without, it is said, engaging in a single battle. In 366 he again invaded the Peloponnesus, but without noteworthy military results. In the mean time the overbearing conduct of Thebes in all international matters, which Epaminondas had endeavored to restrain, produced a great defection among the Arcadians; this was increased by the cruel punishment of the revolted Orchomenus during the absence of Epaminondas in Thessaly, and by many acts of oppression toward the Bœotians and other allies and subject states. The long existing discontent and spirit of revolt was brought to a crisis by the arbitrary refusal of the Theban commander at Tegea to carry out his promised compliance in the ratification of a treaty between the Arcadians and Elis. When the Mantineans sent to Thebes a protest against some oppressive measures taken in connection with this act, Epaminondas defended the commander, and expressed himself in favor of the immediate war which he saw could alone preserve Theban supremacy. Acting against a formidable coalition of Grecian states, which both Athens and Sparta had joined, he for the fourth time invaded the Peloponnesus. The enemy concentrated his force at Mantinea. This was composed mainly of Achæans, Eleans, and Arcadians, while the old Agesilaus was approaching from Sparta, and the Athenian contingent was expected. Having vainly tried to provoke the allies to action before the arrival of the Spartans and Athenians, Epaminondas, aware of the circuitous route of Agesilaus, made a rapid night march from Tegea to surprise Sparta, which was saved by Agesilaus being apprised of the danger in time, and by the bravery of his son Archidamus and other

youths. Epaminondas now turned to surprise Mantinea while the enemy marched to the rescue of Sparta, but the arrival of the Athenians frustrated this attempt also. He finally determined on a pitched battle, which was fought on the plain between Mantinea and Tegea. The plan of the Theban general was similar to that adopted at Leuctra, and the issue would probably have been the same had not his advance been interrupted by a javelin wound. He fell with the point of the broken spear sticking in his breast. He was still alive, but the extraction of the spear head would have terminated his pain with his life. Having been assured that his shield was not lost and that the Thebans were victorious, he inquired for two of his generals, but was told that they were dead. "Then let Thebes make peace with the enemy," said he, and drew out the weapon with his own hand. In reply to his friends, who regretted that he died childless, he said: "I leave two fair daughters, Leuctra and Mantinea." He was buried on the field, and a column, bearing a shield with the device of a dragon, was erected on his grave.

**EPANOMERIA**, a remarkable town in the island of Santorin, the ancient Thera, in the Grecian archipelago, built on the face and edges of a tall cliff at the extremity of a promontory on the N. W. end of the island. The houses, many of which are excavated from the rock, are placed one above another, 15 or 20 deep, the lowest being 400 ft. above the water. They are approached by means of a winding road and staircases cut in the cliff, reaching from the base to the summit. Viewed from the sea, nothing can be more striking than the appearance of this town, with its dwellings high above the masts of the largest ships, or perched on the edges of frightful precipices. On the summit the scene is scarcely less singular, the road there in many places passing over habitations whose existence is denoted only by chimneys jutting up on each side.

**EPÉE, Charles Michel**, abbé de l', a French instructor of the deaf and dumb, born at Versailles, Nov. 25, 1712, died in Paris, Dec. 23, 1789. He studied theology, and gave in his adhesion to the doctrines of the Jansenists, on which account his bishop refused him ordination, unless he would sign a certain formula of doctrine. This he would not consent to, and though admitted to deacon's orders, he was told that he need not aspire to any higher ordination. He then studied law and was admitted to the bar; but at this juncture his old friend M. de Bossuet, a Jansenist, having become bishop of Troyes, offered him a canonry in his cathedral, and admitted him to priest's orders. Hardly was he established in what he hoped was his life work when his patron died, and was succeeded by an orthodox bishop, through whose influence he was suspended from the priesthood. Calling one day upon a neighbor, De l'Épée found that she had two daughters who were deaf and dumb, that a benevolent

priest had endeavored to convey some ideas to them by pictures, but that he was dead, and there was no one who could teach them. He resolved to undertake their instruction, but was not aware that any works had been written upon the subject. Some time after he accidentally obtained a copy of Bonet's *Reduccion de las letras*, &c., in Spanish, and learned that language in order to read it. But the idea of using the natural signs and gestures to communicate information to the deaf mute was unquestionably original with him. (See DEAF AND DUMB.) From 1755, the date of his first establishment of a school for deaf mutes, till his death in 1789, he supported the school entirely at his own expense. As it soon became large, and his patrimony was but small, he was compelled to exercise the most rigid economy. Even in his 76th year he deprived himself of fire in his own room in order to sustain his school, refusing to receive the children of those who were able to remunerate him, or to accept the gifts offered him by Catharine II. of Russia and Joseph II. of Austria. A bronze statue has been erected to the memory of De l'Épée at Versailles, and a bass-relief placed in the church of St. Sulpice by citizens of Sweden. In 1855 the centennial anniversary of the establishment of his school for deaf mutes was celebrated at Paris, and was largely attended by delegations from institutions for the deaf and dumb in other countries of Europe. De l'Épée wrote *Institution des sourds et muets* (2 vols., Paris, 1774), which was revised and republished in 1784 under the title *La véritable manière d'instruire les sourds et muets*.

**EPERIES** (Hun. *Eperjes*), a town of northern Hungary, on the Tarcza, capital of the county of Sáros, 142 m. N. E. of Pesth; pop. in 1869, 10,772, nearly all Germans and Slavs. It is one of the most ancient and interesting, and after Kaschau the handsomest of the towns of Upper Hungary. It is the seat of a bishop of the United Greek church, and has a Lutheran college embracing a theological institution and a gymnasium, and a Roman Catholic gymnasium. It carries on a brisk trade, chiefly in corn, linen, wine, and cattle, and has manufactures of earthenware and woollen goods.—In 1687 the imperial general Caraffa established here the famous bloody tribunal which caused the torturing and execution of a very large number of patriots, especially Protestants. The executions took place on the public square before the windows of the general, and death on the gallows was regarded as comparatively mild and merciful. In 1848 and 1849 Eperies was successively in the possession of the revolutionists, of the Austrians, and of the Russians.

**ÉPERNAY**, a town of Champagne, France, in the department of Marne, on the left bank of the river Marne and on the line of the Eastern railway, 20 m. W. N. W. of Châlons and 74 m. E. N. E. of Paris; pop. in 1866, 11,704. It is well built, and stands in the midst of a fertile and picturesque valley. In its suburbs are many

villas and large estates of much beauty, and the Marne, which is here crossed by a stone bridge of seven arches, is bordered by fine buildings and their grounds. Epernay is the leading entrepôt of the trade in Champagne wine, and immense vaults in which this is stored in great quantities are quarried in the chalk which underlies the neighborhood. The place has also a considerable trade in other products, and manufactures of hosiery, fine pottery, woollen thread, &c. It is the seat of a court of first resort, and has a communal college, a public library of 18,000 volumes, a parish church built in the Italian style and finished in 1832, a theatre, and a city hall of excellent architecture.—The town is very old, and during the reigns of the early Carolingian monarchs was the property of the church of Rheims. It was burned by Francis I. in 1544 to prevent its falling into the hands of Charles V., but the king afterward caused it to be rebuilt. It was a part of the dowry assigned to Mary Stuart, queen of Scots, and it was sold to pay her ransom in 1569. Henry of Navarre captured it in 1592, during the wars of the league; Marshal Biron fell in the attack. In 1642 it became subject to the duke de Bouillon, who gave in exchange for it the county of Sedan.

**EPHAH**, a measure in use among the Hebrews. As a liquid measure, it was the same as the bath or firkin, and contained about  $7\frac{1}{2}$  gallons. As a dry or hollow measure, it was one tenth of the homer, and was equal to 10 omers or gomers. It held a little more than  $1\frac{1}{3}$  bushel of our measure. But there was a difference between the measures, weights, &c., of the Hebrews before and after the captivity.

**EPHEMERA** (Gr. *ἐφήμερος*, that which lasts a day), the name given by Linnæus to a genus of insects of the order *neuroptera*, so named from their appearing in the winged state only for a day, though in the larva and nymph states they are said to live beneath the surface of the water for two or three years. Appearing above this, in the air, generally toward evening in fine summer weather, they provide for the continuation of their race and die. The body is long, slender, and soft, the wings of very unequal size, and the abdomen with long articulated appendages. They are usually called May flies. Though but frail and delicate insects, they have been found in certain districts in France covering the ground in such enormous numbers as to be collected by cart loads for manure. One species, the *ephemera albi pennis*, or white-winged, is sometimes seen in such quantities by the banks of rivers as to whiten the air and the ground like drifting snow.

**EPHESIANS, Epistle to the**, one of the canonical books of the New Testament. It consists of two parts, the first (ch. i. to iii. 21) being chiefly doctrinal, the second hortatory and practical. The epistle purports to have been written by the apostle Paul during his captivity. Its Pauline origin, generally recognized by the ancient church as well as by the

early heretical sects, was for the first time called into question by Usteri (*Entwicklung des Paulinischen Lehrbegriffs*, Zürich, 1824), Schleiermacher (*Einleitung in das N. T.*), and DeWette (*Einleitung in die kanonischen Bücher des N. T.*), chiefly an account of the style of the epistle, which in their opinion shows marked peculiarities. The Tübingen school, in particular Baur (*Paulus der Apostel*, 1845) and Schwegler (*Das nachapostolische Zeitalter*, 1845), disputes its Pauline origin, on the ground that the epistle contains doctrines which are entirely foreign to the genuine Pauline epistles. According to Schwegler, it contains the principles of the Montanists, while Baur believes it to be pervaded by Gnostic views. The majority, however, even of the theologians of the liberal schools (among them Reuss, Rückert, and Schenkel), defend its authenticity.—According to the opening words, the epistle was addressed “to the saints that are in Ephesus,” but the words “in Ephesus” are omitted in the most ancient manuscripts extant (Vatican and Sinaitic codices), and appear to have been unknown to the earliest church writers. Hence some theologians, as Grotius and Paley, have adopted the opinion of Marcion that it was addressed to the church of Laodicea, and that it really is the epistle to the Laodiceans mentioned in Coloss. iv. 16, and commonly supposed to be lost. Others, as Archbishop Usher, Bleek, and probably the majority of modern exegetical writers, maintain that it was a circular letter for the use of several churches. It was formerly the common belief that the epistle was written at Rome about A. D. 57; but the opinion, first advanced by David Schulz (*Studien und Kritiken*, 1829), that Cæsarea has better claims than Rome, has been adopted by a considerable number of prominent theologians, as Schneckenburger, Schott, Wiggers, Thiersch, Reuss, Meyer, and Schenkel, who generally assume that it was written about 60 or 61, simultaneously with the epistle to the Colossians and Philemon. Special commentaries on this epistle have been written by Matthies (1834) and Rückert (1834). See also Bleek, *Vorlesungen über die Briefe an die Kolosser, den Philemon und die Ephesier* (1865).

**EPHESUS**, one of the twelve Ionian cities of Asia Minor, on the S. side of the Cayster, near its mouth on the W. coast. It was said to have been founded by the Amazons, whose legend is connected with Artemis or Diana, the deity of Ephesus. Strabo says that it was settled by the Carians and Leleges, who were driven out by the Ionians. It was besieged by Croesus, and passed successively under the power of Persia, Macedon, and Rome. The Romans made it the capital of the proconsular province of western Asia, and the centre of a great commerce.—Its rich territory, central situation, and the energy of its Greek population gave Ephesus great prosperity. It was

the native place of Parrhasius, Heraclitus, Hermodorus, and Hipponax, the inventor of parody, and claimed to be the birthplace of Homer. But its chief glory was its magnificent temple of Diana, and the city did not fall into decay until the Goths destroyed the temple. The Ionian colonists found the worship of Diana established and the foundations of the temple laid. It was enlarged and seven times restored at the expense of all Asia. During the night on which Alexander the Great was born, in 356 B. C., this magnificent structure was burned to the ground by the caprice of a certain Erostratus, who avowed that he had no other object than to immortalize his name. While it was rebuilding Alexander offered to pay all the expense if he might be allowed to place his name upon it; but the Ephesians refused, and the temple was built by the people generally, the work extending over 220 years. It was

John also lived in Ephesus, and addressed to the church there one of the messages in the Apocalypse. It was the resort of sorcerers and magicians, and the "Ephesian letters" were celebrated magical charms, even to the 6th century. Several Christian councils were held here; the most important of which were the assembly of the bishops of Asia convoked in 196 to fix the day for the celebration of Easter, the third oecumenical council in 431, and the famous "robber synod" in 449. (See CYRIL OF ALEXANDRIA, and EUTYCHES.) About A. D. 260 the city was sacked by the Goths, who burnt the temple; but the final destruction of the latter is supposed to have taken place in the following century. During the Byzantine period Ephesus was the see of an archbishop, but it dwindled in population, its port became choked, and its plains, from want of drainage and cultivation, unhealthy. In

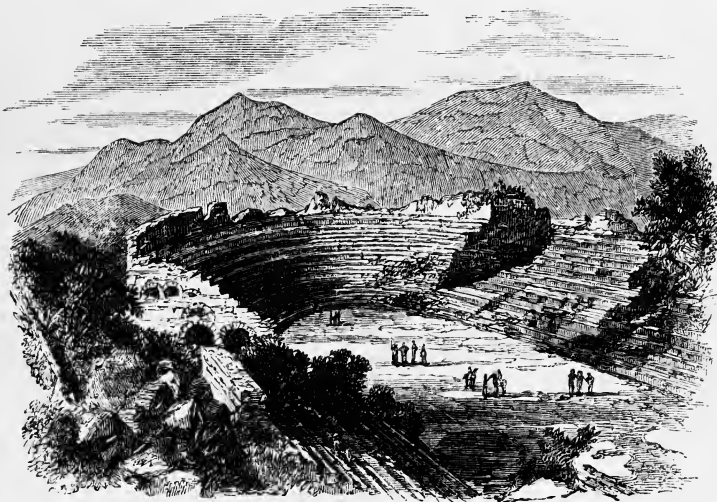

Remains of an ancient Amphitheatre.

425 ft. long and 220 ft. wide, being the largest of the Greek temples, and four times as large as the Parthenon at Athens. It was magnificently decorated with sculptures by Praxiteles and a great painting by Apelles. The statue of Diana was of ivory, furnished with exquisitely wrought golden ornaments. The temple had the right of asylum, which extended to the land around it, and caused the city to be overrun with criminals until the limits were narrowed by Augustus. The medals of Ephesus under the emperors bore a representation of the temple, which was counted one of the seven wonders of the world. It was still the most notable thing about the city when St. Paul preached there in the year 54. The commerce of the place attracted many Jews in apostolic times, and this led the apostle Paul to found there a Christian church, and to remain there over two years. The apostle

the 11th century it was attacked by Turkish pirates, who were, however, driven out. In the 13th century it was alternately in the hands of the Mussulmans and their foes, but in 1308 fell finally under the Turkish power, and was held by one or another Turkish sultan. The ancient city almost entirely disappeared before the modern era, even the site of the temple being lost, the ruins having been in great part carried away for the construction of later buildings, while the rapid formation of alluvial soil buried

many beneath the surface. Several small Turkish villages occupy the ground, the most important of which is Ayasalook, 48 m. S. of Smyrna by the railway to Aidin.—In 1863 an Englishman, Mr. J. T. Wood, found in the ruins of the Odeum two letters from Antoninus Pius to the Ephesians (A. D. 145–150), and in the great theatre one from the emperor Hadrian to the Ephesians, dated Sept. 27, 120; besides an inscription containing particulars as to the endowment and ritual of the temple of Diana. A clause in this inscription ordered that certain processions should go through the Magnesian gate to the great theatre, and thence through the Coressian gate back to the temple; this gave the first clue to the site of the temple. The great theatre appears to have been large enough to contain 50,000 persons. After clearing this out Mr. Wood discovered a gate which he supposed to be the Magnesian gate;



and outside of this, at a depth of 11 ft., was a road leading N. W., and on its side a row of bases of square piers such as might have supported a stoa or covered portico. This he supposed to be the stoa built by Damianus in the 2d century from the Magnesian gate to the temple, to shelter processions in bad weather. He discovered also another similar road from another gate, and standing at the point where these two roads would converge, he found in 1869 the angle of an enclosing wall, with an inscription to the effect that Augustus had built the wall around the temple of Diana out of the revenues of the goddess. This wall he traced for 1,200 ft. until it turned westward, and within this enclosure he found by sinking pits extensive Roman foundations, a mosaic representing a Triton, many inscriptions, a pavement of Greek character, and fragments of statuary, besides several drums of Ionic columns of white marble. In 1871 the wall of the cella on the south and remains of piers came in sight; and on the west were found the lower drum of a column nearly entire weighing  $7\frac{1}{2}$  tons, with figures in high relief, portions of other drums, and the sculptured base of a column and an Ionic capital, according with Pliny's description of the 36 sculptured columns of the temple. Many of the fragments and inscriptions discovered have been sent to the British museum. S. E. of Mount Prion, near the city, is the grotto of the seven sleepers, who are said to have taken refuge here from the persecutions during the reign of Diocletian, and falling asleep to have waked 200 years after and come into the city. The tradition was received by Mohammed and embodied in the Koran, and the cave is a place of pilgrimage with Moslems and Christians. The names of the seven sleepers, and also of the dog Ketmehr which slept with them, are revered throughout the East as of talismanic power. Not far from here tradition places the grave of St. John the apostle.

**EPHOD**, one of the articles of the official dress worn by Hebrew priests, consisting of two parts, one covering the breast and the other the back, united upon the shoulders, and sometimes described as thrown over the shoulders, crossed upon the breast, and then carried round the waist to serve as a girdle for the robe. It was of two kinds: one of plain linen, for the priests; and the other, for the high priest, "of gold, and blue, and purple, and scarlet, and fine twined linen," richly embroidered. On the shoulders of the high priest's ephod were two onyx stones, set in gold, having engraved on them the names of the 12 tribes, 6 on each stone; and where it crossed the breast was a square ornament, called the pectoral or breast plate, in which were set 12 precious stones, each bearing the name of one of the 12 tribes engraved on it. The ephod was worn by others besides priests.

**EPHORS** (Gr. *ἐφοροι*, from *ἐφορᾶν*, to oversee), popular magistrates at Sparta. The origin of

the office seems to have been too ancient for its institution to be historically traced. The authority of the ephors was designed as a counterpoise to that of the kings and council. They were five in number, and chosen from and by the people without any qualification of age or property. The mode of their election is not known. Aristotle calls it puerile, and it is supposed to have been by lot. They held their office for one year, entering upon it at the autumnal solstice, the beginning of the Lacedæmonian year. They met daily and took their meals together, in the building in which foreigners and ambassadors were entertained. They had judicial authority in civil cases, and the power to scrutinize the conduct of all magistrates. In early times the privileges of the office were very great, and they were gradually increased, until even the kings were called before its tribunal, and the assemblies of the people were convened only by its authority. During the Peloponnesian war the ephors received foreign ambassadors, subscribed treaties of peace, and sent out armies; and even on the battle field the king was attended by two ephors as councillors of war. The ephorality is thought by Müller to have been the cause of the instability and final dissolution of the Spartan state. The kings were obliged to court popular favor in order to uphold their power, and thus, contrary to the spirit of the Spartan constitution, the government became a democracy. The ephors became at length associated with all opposition to the extension of popular privileges, and the office was abolished by Cleomenes III. (about 225 B. C.), but restored by the Romans.

**EPHRAEM SYRUS**, the most prominent instructor of the old Syrian church, and one of the most prolific theological writers of the early Christian church in general, died probably in 378. He was born at Nisibis or Edessa, and was educated by Jacob of Nisibis, who took him to the council of Nice. He entered on a monastic life, and carried on his philosophical studies, only coming out to preach and teach. His reputation for learning and piety was so great that he was elected bishop, but declined the office. He spent the greater part of his life in writing and preaching on devotional and moral subjects, and against the heresies of his time, especially Arianism. When Edessa was suffering from famine, he called on the rich to assist the poor, and saw that the latter received what was intended for them. He was called by his countrymen the cithara of the Holy Ghost, and, because he transplanted Greek learning into the Syrian church, the prophet of the Syrians. His commentaries extended over the whole Bible. Hymns and prayers which are ascribed to him are still in use in the Chaldean, Syrian, and Maronite churches. Some of his numerous works are extant in the original Syriac, many others exist in Greek, Latin, and Armenian translations, and many are lost. The most complete edition is that of Rome (6 vols., 3 con-

taining the works in Syriac and Latin and 3 the Greek texts, 1732-46). A good German translation of a large portion of his works was published by Pius Zingerle, at Innsbruck (1830-38). A tasteful English translation of several hymns, songs, and homilies was made by Henry Burgess ("Select Metrical Hymns and Homilies of Ephraem Syrus," 2 vols., London, 1853). Bickell has edited *Ephraemi Syri Carmina Nisibena, additis Prolegomenis et Supplemento Lexicorum Syriacorum* (2 vols., Leipsic, 1866).

**EPHRAIM**, second son of Joseph, the founder of the tribe of Ephraim. The tribe occupied one of the finest and most fruitful territories of Palestine, in the very centre of the land. It included most of the province afterward called Samaria, and contained many of the most distinguished places of Palestine between the Jordan and the Mediterranean, having the tribes of Dan and Benjamin on the south and of Manasseh on the north. It was crossed by the mountain range bearing its name. The tribe of Ephraim often appears as the representative of the ten tribes, or the northern Hebrew state, both in historical and prophetic passages of the Scriptures. It held for a long time the ark and the tabernacle at Shiloh. Next to Judah it was the most warlike of the tribes, and gave to Israel several celebrated leaders and kings.

**EPICHARMUS**, a Greek dramatic poet, born on the island of Cos about 540 B. C., died in 450, or according to Lucian in 443. He went to Syracuse about 483, and there passed the remainder of his life. He conceived the idea of transforming the loosely constructed farces of which the Sicilian comedy consisted into pieces as regular and correct as the Athenian tragedies. He effected as great a reform in comedy as Æschylus in tragedy, diminishing the number of the actors, and introducing a more elegant and poetic language and a more elaborate plot. He was the author of 52, or according to some of 35 comedies, of which only the titles remain. His works were especially esteemed by Plato, who makes many quotations from them.

**EPICTETUS**, a Roman Stoic philosopher, born in Hierapolis, Phrygia, in the 1st century of our era, died in the first half of the 2d century. In his youth he was a slave of Epaphroditus, one of the guards of Nero. Epaphroditus having struck him heavily on the leg, he said to him, "You will break my leg." The prediction was speedily fulfilled, when the philosophic slave said again calmly, "Did not I tell you you would break it?" This extreme insensibility to pain was a fundamental principle in the philosophy of Epictetus. He became a freedman, though neither the cause nor the time of his emancipation is known. He was involved in the proscription by which Domitian banished all philosophers from Rome, and retired to Nicopolis in Epirus, where he opened a school of Stoic philosophy, and held those conversations which have been preserved

in the "Manual" and "Philosophical Lectures" compiled from his discourses by his pupil Arrian. Like the other Stoic philosophers, he taught by his example. He esteemed philosophy to be neither profound speculation nor eloquent discourse, but the love and practice of virtue. His teachings are summed up in the formula, "Bear and forbear." Recognizing only will and reason, his highest conception of life was to be passionless under whatever circumstances. "Man," he said, "is but a pilot; observe the star, hold the rudder, and be not distracted on thy way." Epictetus himself is supposed to have committed nothing to writing. The best edition of all the remaining works of Arrian is that of Schweighäuser, in the collection entitled *Epictetæ Philosophiæ Monumenta* (5 vols. 8vo, Leipsic, 1799-1800). They were translated into English by Elizabeth Carter (London, 1758). A new translation by T. W. Higginson, with a sketch of Epictetus, appeared in Boston in 1865.

**EPICURUS**, a Greek philosopher, born in the island of Samos in 342 B. C., died in 270. When 18 years of age he went to Athens, where he became a pupil of Pamphilus, and an admirer of the doctrines of Democritus. He travelled for several years, and in his 30th year established a school of philosophy at Athens, to which his fame soon attracted a great number of pupils. With them he constituted a community which has always been considered as a model of its kind. He enjoyed the respect and love of his followers to such a degree that his sayings had almost the value of oracles. No other ancient school of philosophy has evinced a cohesive power equal to that of Epicurus. Epicureanism has become almost a synonyme of sensualism, or at least a refined voluptuousness, but nothing was further from the meaning of his doctrines. It is true that he taught *εὐδαιμονία* to be the highest end and purpose of human life, but this word was intended to designate a state of supreme mental bliss, to be attained only by temperance, chastity, and a healthy intellectual development. That bliss, consisting in a perfect repose of mind, in an equilibrium of all mental faculties and passions, is perhaps not very different from the state of mind which the Stoics considered the acme of human perfection, although they were the most unrelenting adversaries of Epicureanism. Epicurus was a man of unsullied morality. Diogenes Laërtius estimates the number of his works at 300 or more. He boasted of having never used any quotations in order to swell his volumes. Few of his writings have been preserved, but a full analysis of his doctrines is to be found in Diogenes Laërtius, and this, taken in connection with numerous passages in the writings of Lucretius, Cicero, Pliny, and others, gives us a full insight into his philosophical system. Within the present century a fragment of his book on nature has been recovered from the ruins of Herculaneum, and published by Orelli

(Leipsic, 1818). Philosophy, according to Epicurus, is the exertion to obtain happiness by reasoning. The supreme bliss (*eudaimonia*) is enjoyment and perfect freedom from pain. Enjoyment is either passive, when a perfect repose of mind is its principal condition, or active. The former is preferable to the latter. It is the state of absolute freedom from pain. Sensations, whether agreeable or disagreeable, are of the same nature; it is only the consequences which constitute their difference. Hence it is the province of reason to discern them according to the ultimate effect they produce. Virtue in itself, irrespective of its consequences, has no value. It is merely the result of wisdom and sagacity, which prove to man that happiness is only to be attained by charity, peacefulness, temperance, patience, self-command. Human or natural rights are merely restraints of individual action, imposed by the necessities of social life. It is self-interest which enjoins us to do right. The repose of mind which constitutes human happiness being continuously disturbed by the uncertainty of the relations of man to the universe and divinity, Epicurus proposed to dispel that uncertainty by a reconstruction of the atomistic theories of Democritus in the following manner: Nothing comes from nothing. That which exists can never be annihilated. All matter consists of atoms, and these are unchangeable and indivisible, although filling a certain space. Besides shape, volume, gravity, and motion, they have no properties. Their number is infinite, their shape infinitely varied. The universe is infinite, and, considered as a unit, unchangeable; for the aggregate quantity of matter remains always the same, however its component parts may combine. The universe cannot be the product of divine action, or else the existence of evil could not be accounted for. The atoms, blindly drifting through infinite space, and declining somewhat from their course (through an accidental cause, whose nature Epicurus fails to explain), are mingled together, shove and push one another (the chaos), until the homogeneous ones associate. The light round atoms (the atoms of fire) are pushed upward, where they form the celestial bodies; those which are somewhat heavier form the air, while the heaviest are precipitated as water and earth. In a similar way the different objects on earth are formed. But the whole process is merely an accidental aggregation of atoms; higher ends and divine laws are mere inventions of the human mind. The psychology of Epicurus flows directly from his natural philosophy. The human soul, according to him, is a delicate and extremely mobile substance, consisting of the minutest round atoms. Its elements are warmth, air, breath, and another nameless substance on which sensibility depends. While the three first named are distributed through the whole body, the fourth has its seat principally in the pectoral cavity, and is, as it were,

the soul of the soul. The soul is not immortal; nevertheless death is by no means to be considered as an evil, since after death no consciousness of annihilation remains. Of all objects filling space infinitely delicate images are secreted. These images, coming into contact with the organs of sense, create perceptions. The conceptions of imagination are arbitrary combinations of such delicate images of real objects. By frequent perceptions the human mind attains to general abstractions, which are merely collective conceptions of the features common to a larger or smaller number of individual perceptions. Since the senses are the receivers of mechanical secretions of objects (images), the knowledge obtained through them is real and objective, the only correct standard of truth; but the workings of imagination, being likewise the result of sensitive perception, although an indirect one, point also to existing realities. Hence it follows that the universality of the belief in the existence of a Supreme Being is proof conclusive of such existence. The gods are living beings, of human shape but colossal proportions. They also consist of atoms. They are immortal, although their bodies are similar to the human body. This contradiction is explained by a certain equilibrium of contrasts in the universe. The gods are living in eternal bliss, that is to say, in absolute inactivity, in the quiet enjoyment of sublime wisdom and virtue. The spaces between the different celestial bodies (*intermundia*) are the seats of the gods.

**EPIDAMNUS.** See DYRRHACHIUM.

**EPIDAUROS** (now *Epidavro*), an ancient city of Greece, on the eastern shore of the Peloponnesus, on the Saronic gulf, nearly opposite the harbors of Athens, from which it was distant only a six hours' sail, in the district called Argolis after the decline of Grecian power. Throughout the period of the country's greatness the city and its adjacent territory formed a small independent state. According to Strabo, it was founded by a Carian colony, and originally named Epicurus. It subsequently received an Argive colony, and became a part of the Doric league, of which Argos was the head. It severed its connection with Argos, however, and during the Peloponnesian war was an ally of Sparta. It had an aristocratic constitution, was an important commercial city, and colonized Ægina; but it rapidly declined in the 6th century B. C., its commerce passing into the hands of the Æginetans. It was chiefly distinguished for its splendid temple of Æsculapius, bearing the inscription, "Let only pure souls enter here," which stood five miles west of the city on the road to Argos, between two mountains, in a thickly wooded grove, in which it was unlawful for any one to be born or to die. The temple was near the centre of this sacred grove, and contained a gold and ivory statue of the god. Near the temple were the Tholus, a circular structure containing medicines for all diseases, a theatre, the bath of Æsculapius,

and temples dedicated to other divinities. Pilgrimages were made to this temple by the sick, and every four years a festival was celebrated here. It was plundered by the Romans. Some of its foundations are still traced, and the theatre is one of the best preserved of all the old Greek edifices. The modern Epidavro is a small village, noted as the place of assembly of the first Greek congress in 1821, which promulgated the constitution called after the place.

**EPIDEMIC DISEASES** (Gr. *ἐπί*, upon, and *δημος*, people) are those which attack at the same time a great number of persons in a given locality, depending on some temporary, accidental, and generally inappreciable cause; differing in this respect from endemic diseases, or those developed under the influence of some constant or periodic cause. Many diseases, ordinarily sporadic, may become epidemic under certain ill-understood conditions; or some new disease, introduced by contagion or other favorable circumstances, may spread epidemically. Having ascertained the cause, or the epidemic tendency of the season, the treatment must depend on the nature of the disease and the constitution of the patient; even when remedial measures seem powerless, the physician can do much to check an epidemic by inspiring confidence and moral courage, and by withdrawing the attention of a community from the continual consideration of any supposed causes. The human constitution may become acclimated to epidemic diseases in malarious climates, as is shown by the greater mortality among new comers. In the white races there is no acclimation against endemics of intermittent and bilious fevers and other marsh diseases, as the experience of our southern states and the Pontine marshes of Italy fully proves. Negroes to a certain extent become insusceptible to the effluvia of the rice fields, but not so much so to the causes of disease on the cotton plantation; they suffer more than whites from cholera, typhoid diseases, plague, and smallpox, but are much less liable to intermittents, and the smallest admixture of negro blood is a great protection against yellow fever. (See **ACCLIMATION**.)

**EPIDERMIS**, or **Cuticle**, the thin semi-transparent pellicle which covers the surface of the dermis or true skin. It is composed of layers of tessellated or pavement epithelium cells, of a flattened oval or polygonal shape, and about  $\frac{1}{1000}$  of an inch in diameter; each cell contains a nucleus with several distinct paler granules. The cells are developed from germs supplied by the basement membrane, nourished by the subjacent vessels, and cast off externally from time to time, to be succeeded by others; when first formed they are spherical, gradually becoming dry and flattened; the deeper layers are more distinctly cellular, while the outer ones are scale-like. The epidermis has no vessels nor nerves, but is pierced by the ducts of the sebaceous and sweat glands, and by the shafts of

the hair or feathers. The rete mucosum seems to be composed of the same microscopic elements as the overlying epidermis, being the principal seat of the pigment cells which give the color to the skin. The epidermis covers the whole exterior of the body, even the front of the eye, and is continuous with the epithelium of the internal mucous membrane; it is thickest in those parts most subjected to friction, as on the heel and the palms of the hands, where it becomes almost as hard as horn. Its use is to protect the sensitive true skin from mechanical injury or the contact of air; in the living body, when abraded, it is speedily replaced; but when it is removed after death, the cutis underneath soon becomes brown and dry. The chemical composition of the thick epidermis of the heel has been found to be very nearly the same as that of the corneous matter of nails, hoofs, horns, and hair. The epidermis is familiarly seen in the occurrence of blisters, constituting the raised portion under which the fluid is effused. The epidermis prevents not only evaporation from the dermis, but also absorption of fluids from without; it is well known to the physician that in introducing medicinal agents into the system by the endermic method, the process is rendered very much more rapid and effectual by previously removing the epidermis by a blister.

**EPIGONI** (Gr. *ἐπίγονοι*, descendants), the seven sons of the seven Argive heroes who, under command of Adrastus, made an unsuccessful expedition against Thebes, in which all but the leader lost their lives. At the suggestion of Adrastus, the sons made war on Thebes ten years later, to avenge the death of their fathers. Their names are not the same in all the accounts, but as usually given they are Alcmaeon, Ægialeus, Diomedes, Promachus, Sthenelus, Thersander, and Euryalus. Under command of Alcmaeon, the Argive forces attacked and defeated the Thebans, who lost their leader, Laodamas; while of the Epigoni, Ægialeus, the son of Adrastus, was slain. The Thebans then abandoned their city and sued for peace, but the Argives razed it to the ground. This war of the Epigoni was celebrated in verse, and statues of the seven heroes were erected at Delphi.

**EPILEPSY** (Gr. *ἐπιληψία*, from *ἐπιλαμβάνειν*, to seize upon), a disease characterized by sudden and temporary seizures of unconsciousness, accompanied by convulsions. This is one of the most horrible diseases that afflict mankind, and it is not surprising that in ignorant ages, in Rome, in Egypt, and elsewhere, epileptics were considered as having excited the anger of the gods, or were worshipped as possessing supernatural powers. This was due to the violence and extraordinary force developed by the muscles in epileptic convulsions; the screaming, the changes in color, the contortions of the face, and the biting of the tongue, followed by a comatose state and afterward by a degree of mental alienation. There are so

many varieties of epilepsy that it is impossible to give a definition of the disease that will apply to them all. In most cases it is characterized by convulsions and loss of consciousness, occurring at longer or shorter intervals, during which the patient is almost in good health. The absence of fever in epileptics serves to distinguish their affection from meningitis and other inflammations accompanied by convulsions. The complete loss of consciousness also distinguishes epilepsy from hysteria. As in most nervous diseases, a hereditary tendency is among the most frequent predisposing causes of epilepsy. Epilepsy often appears in the offspring of persons who have had various other nervous complaints. Bouchet and Cazauviehl say that out of 130 epileptics 30 were descendants of persons who had been either epileptic, insane, paralytic, apoplectic, or hysteric. There is no doubt that women are much more frequently attacked by epilepsy than men. We find by a comparison of the statistics given by several English and French authorities, that the most frequent periods at which epilepsy begins are early infancy and the age of puberty. It often appears also in very old age; Delasiauve remarked that out of 285 epileptics the disease began in 10 when they were from 60 to 80 years old. In fact, no age escapes. As regards climate, nothing very positive has been established, but it seems probable that the disease is more frequent in hot and in very cold than in temperate climates. Herpin and others say that epilepsy is more common in persons of low stature; but even if this be true, Herpin is wrong in considering shortness of stature a predisposing cause of the disease, as in many of the cases on which he grounds his view it is partly the influence of epilepsy that has prevented the development of the body. Various malformations of the body, and especially of the cranium, are certainly among the most frequent predisposing causes. Weak constitutions, as proved by Esquirol and Dr. C. B. Radcliffe, are favorable to the production of epilepsy. Among other predisposing causes are dentition, the first appearance and the cessation of menstruation, onanism, and the abuse of alcoholic drinks. Almost all kinds of diseases may produce epilepsy, but among the principal we must place those affections in which the blood becomes altered or diminished, and organic affections of the membranes of the cerebro-spinal axis and of certain parts of this nervous centre. Another very powerful cause, the influence of which has been demonstrated by Marshall Hall, Kussmaul, Jenner, and Brown-Séguard, is excessive loss of blood. Pregnancy, parturition, and menstruation frequently cause epilepsy. A tumor on a nerve, or any cause of irritation on the trunk of the terminal part of any sensitive nerve, and especially in the skin or mucous membrane, very often produces it. A wound, a burn, worms in the bowels or elsewhere, stone in the bladder or in other places, a foreign

body in the ear, &c., are known to have caused epilepsy. It is quite certain that great mental excitement has originated it in many cases, but it seems probable that the disease was not introduced by those causes, but was only brought by them to manifest itself.—When a complete fit is about to take place, it is usually preceded by some sensation or some change in the mind of the patient. If a sensation precedes the fit, it comes most frequently from some part of the skin, and especially from that of the fingers or toes. This sensation is well known under the name of *aura epileptica*. There is as much variation in the kind and the intensity of the sensation as in its point of starting. Most frequently the aura is a sensation of cold, of burning, or that kind of sensation produced by a draft of cold air on a limited part of the body. Sometimes the aura starts from the eye or the ear, and then a flash of light or some other sensation comes from the retina, or peculiar sounds are heard. Some epileptics become gay, others mournful, when they are about to have a fit; in others the attack is announced by some change in the digestive functions. A complete attack usually begins with an extreme paleness of the face, and at the same time or nearly so there are contractions of several muscles of the face, the eye, and the neck. Observers do not agree as regards the first manifestation of a fit, probably because the seizure does not always begin with the same phenomenon. Not only have we known the first symptom not to be the same in different epileptics, but in the same one we have seen differences in three different attacks. Many physicians think the scream is the first symptom. It often is, but the paleness of the face usually precedes it. Some epileptics do not scream. As soon as these symptoms have appeared, a rigid tetanic or at least tonic spasm takes place in the limbs, and the patient falls. Respiration is suspended, and the face becomes quite injected with black blood, and assumes a hideous aspect both from the spasms of its muscles and the blackish or bluish hue. Sometimes a momentary relaxation is then observed in the limbs; but almost at once clonic convulsions occur everywhere in the trunk, the limbs, the face, and often in the various internal organs of the bladder, the bowels, and even in the uterus. The mouth then ejects a frothy saliva, often reddened with blood from the bitten tongue. The respiratory muscles, after the first spasms which produce the scream and suffocation, causing a gurgling or hissing sound, become relaxed, and then those employed in inspiration contract, and almost as soon as air has reached the lungs the convulsions cease or notably diminish. Ordinarily the fit is over in a few minutes; but it is not unfrequently the case that after a general relaxation another seizure comes on, and sometimes many occur with very short intermissions. During the whole time the fit lasts the patient is deprived of consciousness, and

when he recovers he remembers nothing that has taken place in the mean time. In some cases the seizure is followed by a prolonged coma, ending sometimes in death. When the patient recovers from a fit, even if it has not been very severe, he usually feels fatigued and suffers from headache. Fortunately he soon falls asleep, and ordinarily is almost as well as usual when he wakes, except that the headache and the fatigue still exist, though much diminished. When many fits have taken place, even at somewhat long intervals, such as several weeks, mental derangement often supervenes, and in this way epilepsy leads to insanity. In some cases the fits recur at regular periods; in others they return with every return of the circumstances which seem to have caused the first, such as menstruation, pregnancy, the influence of certain seasons, &c. There is seldom perfect regularity in the length of the intervals between the fits, and they come every day, every week, every month, &c., at irregular hours. Many patients have very different intervals between their successive fits. Some have many fits a day, others one every six months, or every year. Delasiauve mentions a case in which the number of fits was 2,500 in a month. But the greater the number of fits, the less violent they generally are.—In a complete fit of epilepsy there are two distinct features: 1, the loss of consciousness; 2, the muscular convulsions. Each of these may exist alone. In the case of a seizure consisting only in the loss of consciousness without convulsions, we have the so-called epileptic vertigo, which is a form of epilepsy that frequently exists alone, and also coexists often with the form of the disease in which the attack is complete. In this last case the patient sometimes has a complete seizure, sometimes only an attack of vertigo. Whether vertigo exists alone or coexists with complete attacks, it is very dangerous, not for the life of the patient, but because fits of simple vertigo lead more frequently to insanity than complete fits of epilepsy. The cases of epileptiform convulsions without loss of consciousness are not so frequent as the cases of simple vertigo. They are particularly produced by injuries to the nerves or to the spinal cord.—The nature of epilepsy, the material and dynamical conditions of the parts which are affected in the animal organism, have been greatly illustrated by the researches of modern physiologists and practitioners. Dr. Marshall Hall thought its seat to be chiefly in the medulla oblongata, and that its nature consisted in an increased reflex power, at least in the beginning of the disease, and also that the convulsions were the results of the asphyxia caused by the closure of the larynx (*laryngismus*). This theory is in opposition to several facts. In the first place, although *laryngismus* almost always exists and certainly concurs in the production of asphyxia, and in so doing generates convulsions, it cannot be considered the cause

of convulsions, as it does not always exist, and as there is one kind of convulsions (the tonic) which precedes the asphyxia. Besides, there are more powerful causes of asphyxia in the condition of the circulation in the brain and the spasm of the muscles of the chest. Then, as regards the increased reflex power, Dr. Hall acknowledges that this power is diminished in persons who have been epileptic for some time. We cannot admit therefore that the disease consists in the increase of this power. Another theory has been proposed by Dr. Brown-Séguard. Guided by experiments on animals, in which he produces epilepsy, he has found that the reflex power is composed of two distinct powers, one of which he calls the reflex force and the other the reflex excitability. He has found that the reflex force may be very much diminished while the reflex excitability is very much increased. This last power is the power of impressibility of the cerebro-spinal axis; in epileptics this impressibility is very much augmented. The slightest excitations may produce reflex actions in them. In the beginning of epilepsy, usually the other reflex power, which is the force manifested in the reflex actions of the cerebro-spinal axis, is increased; but after a time this force diminishes, and in most cases it becomes less, and even much less, than in healthy people. The nature of epilepsy seems to consist in an increase of the impressibility, or in other words of the reflex excitability of certain parts of the cerebro-spinal axis. In most cases of epilepsy these parts are the medulla oblongata and the neighboring parts of the encephalon and of the spinal cord. But the seat is not constant, and may be sometimes limited to the oblong medulla or extended to other parts of the cerebro-spinal axis. Dr. Brown-Séguard has tried to explain the mysterious phenomenon of loss of consciousness. It seemed very strange that at the same time that certain parts of the encephalon were acting with great energy, another part should be completely deprived of action. This, according to him, is very simple. The blood vessels of that part of the brain which is the seat of consciousness and of the mental faculties receive nerves from the medulla oblongata and the spinal cord; these blood vessels when they are excited contract and expel the blood they normally contain, and it is known that all the functions of that part of the brain cease when they do not receive blood. When the excitation that exists in the beginning of a fit acts upon the medulla oblongata and its neighborhood, it produces at the same time the contraction of the blood vessels of that part of the brain which we have mentioned, and a convulsive contraction of the muscles of the face, the eye, the neck, the larynx, &c., all parts receiving nerves from the same source as these blood vessels. In this way the loss of consciousness is explained. The following table from Dr. Brown-Séguard's work on epilepsy shows how the principal phenomena are generated:

CAUSES.	EFFECTS.
1. Starting of an excitation from a sensitive or an excitable part of the nervous system.	1. Contraction of the blood vessels of the brain proper, and contraction of some muscles, by a reflex action from the central seat of the disease.
2. Contraction of the blood vessels of the brain proper.	2. Loss of consciousness.
3. Accumulation of blood at the base of the encephalon, due to its expulsion from the brain proper, &c.	3. Spasm of the larynx and of the muscles employed in expiration.
4. Spasm of larynx and of expiratory muscles.	4. Cry and asphyxia.
5. Asphyxia.	5. General clonic convulsions.
6. Exhaustion of nervous power, except of the part of the nervous centres employed in respiration.	6. Cessation of the convulsions and return of respiration.
7. Return of respiration.	7. Return of consciousness.

—The first thing to be done for an epileptic is to find out the cause of the disease, and to try to get rid of that cause if it still exists. Very often epilepsy depends upon some external cause of irritation which may easily be removed; it is of the greatest importance to discover if there is anywhere such an irritation, and as the patient may not be aware of its existence, it is necessary to look for it everywhere. Of the various modes of treatment, the most powerful are those means of exciting the skin which most readily produce a change in the nutrition of the encephalon and spinal cord. All physicians know what these means are. One of the most efficacious remedies is belladonna. Patients and their families should remember that the rules of hygiene must be followed by epileptics much more closely than by those afflicted with almost any other disease.

**EPIMENIDES**, a poet and hero of Cnossus, in the island of Crete, flourished in the 7th century B. C. He was a contemporary of the seven wise men of Greece, among whom he is sometimes counted in place of Periander. He was principally occupied with politics and legislation, but of his treatises on these subjects nothing remains. He also wrote a poem on the Argonautic expedition, which is lost. There are many fabulous accounts of his life. He is said to have passed 57 years in profound sleep in a cavern, and to have possessed the marvellous power of separating himself from his body. The Athenians suffering from a plague invoked his aid, and he removed the scourge. His life was prolonged, according to some, to the age of 154, 157, or even 299 years.

**ÉPINAL**, a town of Lorraine, France, capital of the department of Vosges, 195 m. E. S. E. of Paris; pop. in 1866, 11,870. It lies at the foot of the Vosges mountains, on the railway from Nancy to Belfort, and on the river Moselle, which is here separated by an island into two channels, dividing the town into three parts, connected by bridges. The fortifications built in the 13th century have been destroyed, but the ruins of an old castle remain. The town is well built, and has a Gothic church of the 14th century, a theatre, hospital, communal

college, museum, and public library of 20,000 volumes, tanneries, and manufactories of cutlery, copper, china ware, paper, and oil. It was occupied by the Germans Oct. 11, 1870. Marble of various colors and freestone are quarried in the vicinity.

**ÉPINAY, Louise Florence Pétronille de la Live d'**, a French authoress, born in 1725, died April 17, 1783. She was unhappily married, and while yet young became the mistress of Jean Jacques Rousseau, for whom she built in 1755 his celebrated "Hermitage," and with whom she lived till he became jealous of Grimm, introduced to her by himself. He was also jealous of her friends Diderot and D'Holbach. She lived in seclusion for the last 25 years, but maintained intimate relations with Grimm, and during his absence from France continued, under the guidance of Diderot, his literary correspondence with the sovereigns of Europe. She wrote an educational work entitled *Conversations d'Émilie*, to which a prize was awarded by the French academy in 1783. Her *Mémoires et correspondance* (3 vols., Paris, 1818) contains many letters of Rousseau, Diderot, and Grimm, and abounds with information on French society and character in the 18th century.

**EPIORNIS**, one of the gigantic ostrich-like birds of which the *dinornis* is the type. It was a native of Madagascar, and became extinct probably since the historic period, or at any rate since the appearance of man. The *E. maximus*, judging from the bones of the leg, must have been at least 12 ft. high. The egg measured 13½ in. in length, being as large as 6 ostrich eggs or 144 hen's eggs. This bird, though wingless, may have given rise to the fabled roc; and it must have been seen by primitive man, whose traditions have handed down to eastern nations an exaggerated account of its size.

**EPIPHANIUS, Saint**, a father of the church, born near Eleutheropolis in Palestine about 310, died at sea in 402 or 403. He was of Jewish parentage, but having become a Christian retired to an Egyptian monastery, where he mastered the Hebrew, Coptic, Syriac, Greek, and Latin languages. At the age of 20 he returned to Palestine, founded a monastery which he governed for 30 years, and wrote several books for the instruction of his monks. In 367 he was made bishop of Salamis in Cyprus, as a reward for the zeal with which he had combated the heresy of Arius and the errors attributed to Origen. After the persecution of Valens he made a journey to Antioch to convert the Apollinarian patriarch Vitalis; thence went to Rome, where he met St. Jerome; and some time afterward proceeded to Jerusalem to warn its bishop against the poison of Origenism. Not succeeding in this, he withdrew to the solitude of Bethlehem, and conferred the order of priesthood on Paulinian, brother of St. Jerome, a violation of the canons which drew on him the censure of the diocesan

bishop. Theophilus of Alexandria, at one time a violent partisan of the Origenist doctrines, had openly accused Epiphanius of heresy; but since the elevation of Chrysostom to the see of Constantinople Theophilus had become a violent opponent of Origen, and involved Epiphanius in his hostility to Chrysostom. By his persuasion a council was assembled in Cyprus, at which the writings of Origen were condemned; and when Theophilus was cited by the emperor to appear in the capital and answer for the burning of the Egyptian monasteries and the murder of the Origenist monks, he sent Epiphanius before him to plead his cause. Epiphanius not only refused to communicate with Chrysostom, but conferred holy orders in one of the city churches, assembled a council of bishops, asked of them to subscribe the decrees of the council of Salamis, and pronounced in the church of the Apostles a sentence of excommunication against the adherents of Origen. Reproved for this by Chrysostom, and unable to obtain the approbation of the emperor, he assumed a milder tone toward his opponent, departed for Cyprus, and died during the voyage. His most important work is his *Panarion*, directed against heresies. His style is uncouth, and his matter thrown together without order or connection. A standard edition of his works is that of Petavius (2 vols. fol., Paris, 1622); his works are also published in Migne's *Patrologia Græca* (Paris, 1856-'61).

**EPIPHANY** (Gr. ἐπιφάνεια, manifestation; in the Greek liturgy, τὰ ἑρὰ ἐπιφάνια), the feast of the manifestation of Christ to the gentiles. That this feast was called Epiphany and celebrated in January is attested by Ammianus Marcellinus (xxi. 2), who says Julian kept it at Vienne in Gaul. That it was kept on Jan. 6 is seen in the constitutions of Valens, Theodosius, and Arcadius. Jan. 6 was held to be the day on which the miraculous star led the wise men to Bethlehem, and that on which Christ was baptized in the Jordan, as well as that on which he performed his first public miracle in Cana. St. Paulinus affirms that these three anniversaries were solemnized on this same day in the 4th century. Some African churches commemorated a fourth event, the multiplication of the five loaves by Christ. From the time of the council of Nice (325) this day was set apart throughout the East for the solemn administration of baptism. It was also the custom there, at midnight on the feast of the Epiphany, to fetch water from the springs, which was believed to keep fresh and pure the whole ensuing year. St. Epiphanius says this was done in memory of the water changed into wine at Cana. It was on the Epiphany, in fine, that patriarchs and metropolitans yearly published the "paschal letters" announcing the precise time for the celebration of Easter and Pentecost. Several of them are extant.

**EPIPHYTES** (Gr. ἐπί, upon, and φρεσίν, to grow), vegetable parasites found upon man and other animals. Those which grow within

the cavities of the same are called entophytes. As no definite line can be drawn between the two, and as some species belong to both classes, they will be considered together in the present article. It is only of late, and since much attention has been given to the study of cryptogamic botany, that the full nature and importance of the diseases created by many of these growths have been recognized, and the belief in their spontaneous generation been given up. They all belong to the fungi and algæ, but we are not yet sufficiently advanced in our knowledge of cryptogamiæ to attempt any minute classification, or to distinguish between these two orders. Robin and Küchenmeister divide them according to their supposed place in the vegetable kingdom, while Virchow and his followers classify them into those really pathogonomic of disease, and those accidentally occurring in it. For this last arrangement the two following conditions are necessary, viz.: the constant occurrence of the parasite in the disease, and the positive result of inoculation. There are some who say that even this is not enough, and that the fungus may carry the matter of contagion attached to itself, and that this propagates the disease. Schönlein throws out such a hint with regard to animal parasites when he advises our cleaning the itch insect with brush and bath before proceeding to inoculate; and Clemens of Frankfort asks: "If we were to find constantly in the vaccine matter one and the same fungus, by the transportation of which new variola existed, which should we call the true inoculating matter, the fungus attached to the lymph, or the lymph attached to the spores?" The dwelling places of the cryptogamiæ seem as universal as their growth is simple. Deep under the sea are beds of algæ; within the bowels of the earth they may be found; the air we breathe contains them, and the winds waft them from pole to pole. They form the chief means of resolving dead matter into its original elements, and are present and are gone with a rapidity inconceivable. No wonder that men believed in the spontaneous development of these forms, for their appearance in certain situations seems otherwise inexplicable. The animal parasites live mostly on the living tissues of man or other animals; with the vegetable the reverse is generally the case, and it is those parts already decomposed or diseased which form their chief support. They usually attack, or better succeed in establishing themselves upon, parts not intimately connected with the system and superficial, and therefore less able to resist their influence; or else they attend upon long disease, when the strength of the body is already wasted. This cannot be said however of every species. The character of the soil exercises an important influence over their growth, and may in fact change it entirely. Indeed, we can hardly give any general rules; for some affect an acid nutriment, others alkaline; some



grow upon the outside, where there can be no warmth, others within the heated cavities of the body; some thrive best in light and pure air, others in darkness and carbonic acid; some live in fluid, while others are always found dry. It will be seen then that all these points must be taken into consideration before we attempt to destroy them, and a universal parasite killer is an impossibility, for what is death to one species may be the food of another. The effect of their presence on man is as various as that of the animal parasites, though less dangerous. When the plant has found its favorite and essential elements for reproduction, it grows at once, be it on the outer surface or within the body. At first the growth may be merely superficial; but soon the vegetative structure, the mycelium, begins to seek nourishment in deeper soil, and its filaments penetrate all tissues, wherever the minutest opening is left for its entrance. The spores or mycelium, by acting as a foreign body, may produce absorption in adjacent parts, and thus make way for their progress inward indefinitely. When once the spores gain admission we may see the same result as when we plant the seeds of larger vegetables in the soil. They send forth their sprouts upward and downward, pushing before them whatever resists their progress. But if in addition to the sprouts we should have our seed increasing by self-division, and to an immense extent, what would follow? What wonder then if this process, carried on beneath the less yielding skin, should lead to inflammation and destruction of the parts? The *oidium albicans* may become dangerous to an infant by obstructing the œsophagus or glottis. Impaired vision may be caused by the growth of a fungus within the eye. Atrophy and deformity may result from their presence in the hair and nails. Erosions of the skin, and the inflammation they create, may bring on swelling of glands. Parasites may also prove injurious by irritating the



*Pityriasis versicolor.*

nervous system, as in *pityriasis versicolor*, or chemically. The vinous fermentation is brought about by the action of a fungus on sugar, by which it is resolved into carbonic acid and alcohol. So too the *sarcina ventriculi* and the *oidium albicans* may cause the acetous and lactic acid fermentations respectively. The very decay of vegetable parasites may produce putridity in their masses. We see then that vegetable parasites are able to work a multitude of evils upon mankind, but the extent thereof must be in proportion to the condition and size of the organ affected. Although they may in some instances be as troublesome, as dangerous to life even, as their animal relatives, still we are not so much shocked to have our head covered with the sporules of the favus plant

as with pediculi, though both are marks of uncleanliness, or to know that our stomach is filled with *sarcina*, as to suspect that a frightful *strongylus* lies coiled up in our kidney.—Fungi consist of organs of fructification and a nutritive apparatus. This last is called mycelium, and is made up of threadlike, more or less compacted, elongated cells, which interlace and have no intimate connection. It has such an indefinite form, and differs so little in various species, that from it alone we cannot distinguish them. It varies greatly also according to the condition in which it grows, and whether it be viewed damp or dry. It may exist without bearing fruit, as a tree may remain barren in uncongenial soil; but no species can exist without it, though it may be reduced to a very low development when compared with the fruit-bearing system. Subtile forms of mycelium have the power of penetrating to remote parts, and lying dormant for a long time. The reproductive system consists of spores, which are very small, and in some species are enclosed in receptacles. Their number is literally incalculable, and they increase with immense rapidity. They float freely in water, and their walls are very strong, so that they are well calculated to travel far from their birthplace. Their diminutive size enables them to gain admission into the smallest crevices of the skin or elsewhere, and they are capable of withstanding great extremes of temperature, so that after being kept in a dry state for a long time they are found to possess their entire pristine vitality. The whole plan of their development is still little known, and there is good reason to believe that many of them are imperfectly developed states of other plants, which, if they attained their proper sphere, might present a more complex structure; and when we consider the vast number of forms into which a single germ may develop itself according to the soil in which it happens to grow, their real number may be regarded as comparatively small, and this view is adopted by some eminent dermatologists. Some prey directly upon living tissues, while others destroy them first and induce decomposition, before the proper conditions for their development are attained. The fact of possible inoculation on healthy subjects proves that the presence of some forms at least is the essential cause of the disease connected with them. The fact that mycelium may exist for a long time dormant, till proper conditions are provided for its further development, will explain the sudden appearance of a fungus in various peculiar situations. In the potato disease, for instance, the *botrytis infestans* may show itself in a few hours on the freshly cut surface of a tuber, and on microscopic examination we find mycelium traversing the cells in all directions. They grow within nuts and egg shells, in the cavities of tomatoes when no lesion of the walls exists, and are developed within the brains of birds, in the eye and bladder of man, and on globules of milk within the

udders of cows. Let any room remain undisturbed for any length of time, and then examine the dust which has collected, and multitudes of vegetable spores will be found. We know not but in each breath of air we inhale, each draught we raise to our lips, are lurking germs which, if they find a proper nidus, may make of us a dwelling place.—Among the most important of the vegetable parasites of man is

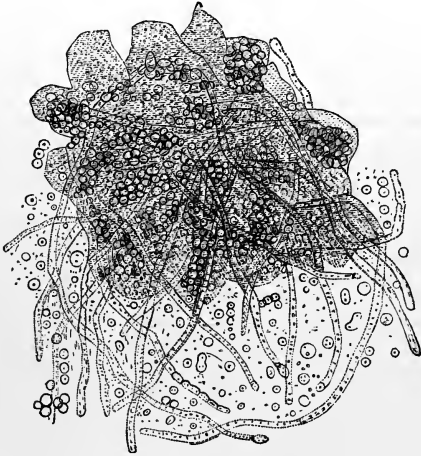

*Oidium albicans.*

the *oidium albicans*, which belongs to the same genus as the fungus which has proved such a destructive pest to the vineyards of southern Europe and Madeira, viz., the *oidium Tuckeri*. It forms the disease called aphthæ, which shows itself on the mucous membrane, generally on the tongue of infants, as a soft, white, pasty, slightly elevated patch. On the lips, where it becomes dry, it forms dark brown crusts. Its seat is first the upper surface of the epithelial cells, but soon its filaments penetrate deeply between them, and can no longer be removed by art. It is found also in the nose, windpipe, stomach, and intestine. It may occur in persons of every age, but especially occurs in young children and the old, owing to the liquid form of their food, which allows any accumulation in the mouth to remain undisturbed, and to the long sleep necessary to these ages. It is of frequent occurrence also in the last stages of many diseases, when the mucous membrane is covered with nitrogenous, decomposable matter. According to Küchenmeister, its appearance is due to catarrh of the mucous membrane, which is very common in old age and infancy, and this is without doubt the most frequent predisposing cause. Robin accounts for its presence on the nipples of nurses by the supposed lactic acid reaction produced there, but it is more probable that the disease is transferred thither with the mucus from the child's mouth, and becomes attached by the extension of the mycelium into the epithelium. *Oidium* has

also been found in the nails and on the surface of ulcers. On diphtheria this parasite is found to be a constant attendant. Whether its presence causes the inflammation of the throat, or is merely the result of a proper nidus offered it by this specific disease, is not easy to determine. In other cases it seems to give little trouble as a general rule, though in very young children it may produce difficulty of breathing and swallowing. The ulceration which is sometimes found is probably caused by the accompanying catarrh. That it is contagious is shown by its rapid spread in large foundling asylums, and by direct experiment. Its general transference from one mouth to another in such localities is easily understood when we consider their customs—the nipple taken from one child and given to another, feeding various children with the same spoon, and so on. How it appears in sporadic cases also is not difficult to explain, believing as we do that it is an ordinary form, which may grow on many substances, and be transported in the form of its spores in all directions by the air.—The diseases caused by these parasites may be divided into three groups: those of the alimentary canal, of the scalp, and of the skin. In the first we place the *oidium albicans* already described, and here too belongs the *torula cerevisia*, or yeast plant, its near relative, which is met with occasionally in all the fluid excretions of the body. It forms the ordinary cholera fungus in the vomitus and intestinal discharges of this disease, and is often found in the stomach and attached to the walls of the intestine after death. Its usual presence in fermenting fluids has led to the belief that it was the cause of such change, and we know that when added as yeast it acts as a true ferment; but we do not know but that the peculiar chemical change may offer merely the conditions for its sudden

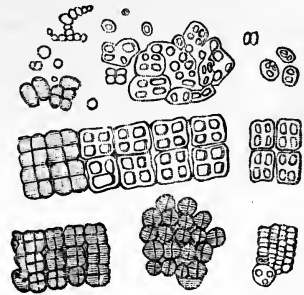

*Merismopedia ventriculi.*

appearance and rapid growth. It is another form of the *penicillium glaucum*. Another plant, found most commonly in the fluid of the stomach, is the *merismopedia* (or *sarcina*) *ventriculi*, which has been usually placed among the algæ. It has been found also in the urine, in the intestinal canal, and in the lungs. Its presence in the stomach of man probably causes no symptoms whatever; it has been cultivated

in the stomach of rabbits, and no trouble caused by its presence. It is supposed to be present most frequently in patients suffering from some gastric disease, organic or otherwise; but this is to be accounted for by the fact that such only vomit, and afford material or stimulus for investigation. If we remove from our teeth the yellowish white deposit which collects after the neglect of the tooth brush for several hours, we shall find by microscopic examination, in addition to the

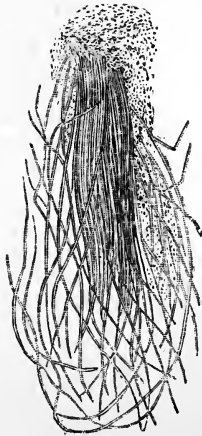

Leptothrix buccalis.

detritus of food, a cryptogamic plant called *leptothrix buccalis*. It is to be found in all persons, however cleanly they may be, and forms a large part of the tartar which collects about the teeth. It grows with great rapidity after eating sugar, and has been seen in the stomach. Of the parasites of the scalp, the *achorion Schenleinii* is most of all to be dreaded, on account of the deformity and disagreeable odor it gives rise to. It produces the disease known as *favus*, *porrigo favosa*, or *tinea lupinosa*. The spores first settle upon the epidermis of the head, and send forth the mycelium, which penetrates the hair follicles and finally the whole course of the hair itself. The hair becomes pale and lustreless, breaks easily, and is surrounded at its base by concentrically marked yellow and roundish crusts, which smell vilely, and consist of spores and mycelium. From one point this fungus may spread over the whole scalp, producing baldness and scars. Fortunately it is of rare occurrence,

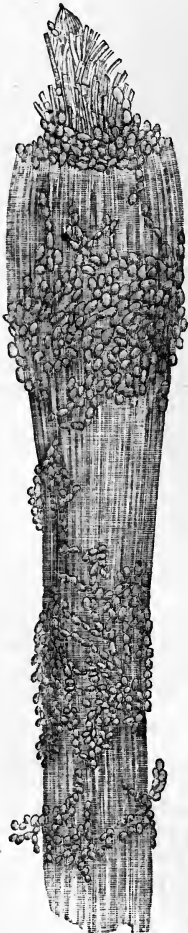

Achorion Schenleinii.

for a cure is almost impossible. The *trichophyton tonsurans* and *T. sporuloides* also cause baldness when they attack the hair, and the former produces the disease called ringworm, which is so prevalent in asylums for children. The *microsporon Audouini* likewise attacks the hair, and the *M. mentagrophytes* the beard. The only vegetable parasite which is found upon the skin alone is the *M. furfur*, which is the cause of the eruption known as *pityriasis versicolor*. Several of the above mentioned species may take root upon the skin as well as the scalp, but they never form a well marked disease like the latter. Various kinds of cryptogamia have been observed within the ear, eye, lungs, and nails, but the descriptions of them are very defective, and we hardly know where they belong. It is probable that they are species of fungi which have accidentally found a favorable place for development.— Man is not the only animal infested by the vegetable parasites. Upon the mammalia it is true that few have been observed, but this remains an almost unexplored field. Many birds bear them in their respiratory apparatus, especially the owls, which inhabit damp and shady retreats, frequented by fungi. More curious is it to find within the close-shut cavity of an egg mycelium spreading throughout the contents, and changing them by a peculiar chemical action. This rare phenomenon is produced by the admission of spores within the oviduct before the egg shell is formed. Fish are often taken covered with vegetable growths, which impede their motion through the water as the barnacles act upon ships. A great many species have also been described which are found only upon their gills and in the cellular tissue. In an aquarium, whenever an injury happens to any of its inhabitants, the wounded surface is seen at once to be covered with fungoid growths, which often attain a large size. But it is the insect tribe which suffers most from this cause; for their diminutive size is little able to cope with the parasite, which when once fastened increases at their expense, till it exceeds them in size and destroys them. Flies may be seen at certain seasons struggling through the air with long stems attached, the mycelium of which spreading inward stops their breathing tubes. Certain species of *sphaeria* grow within the larvæ of insects in China and Australia, and completely mummify them, so that they resemble twigs of wood, from which sprout forth branches. The most



Trichophyton tonsurans.

important of all, in an economic point of view, is the *botrytis Bassiana*, which is so destructive to the silkworm. This disease is called muscardine. The spores enter the air tubes of this worm, sending their mycelium through its tissues, and always cause its death. After this the plant pushes its fruit-bearing stems into the outer world, and converts its victim into a mass of mould, from which fresh spores are sent off to spread the disease. Although it only attacks the larvæ, it may by inoculation be cultivated upon the chrysalis and moth. The intestines of insects and worms which live in decayed wood are often found filled with most curious forms of vegetative life, as Dr. Leidy has shown in the case of the *vilus terrestris*, and the very entozoa which dwell within their intestines are covered with similar growths.—Those who would pursue this subject still further will find much to interest them in the following works: Robin, *Histoire naturelle des végétaux parasites* (2 vols. 8vo, Paris, 1853); Küchenmeister, "Manual of Parasites," translated for the Sydenham society (2 vols. 8vo, London, 1857); Berkeley, "Introduction to Cryptogamic Botany;" and Leidy, "Flora and Fauna within Living Animals," in the "Smithsonian Contributions to Knowledge," vols. v. and vi. (Washington, 1853 and 1854).—The term epiphytes is also applied by botanists to plants which grow upon other vegetables, but which do not derive their nourishment from them. (See AIR PLANTS.)

**EPIRUS**, next to Thessaly the largest province of ancient Greece, in the S. part of modern Albania, bounded N. by the territory of the Græco-Illyrian tribes, E. by Thessaly, S. by Ætolia, Acarnania, and the Ambracian gulf (now gulf of Arta), and W. by the Ionian sea. The Ceraunian mountains separated it from Grecian Illyria; the Pindus, famous in mythology, from Thessaly. Its climate was mild, and its soil less fertile than that of other parts of Greece. The river Acheron received the waters of the Cocytus within its limits, and flowed into the Ionian sea. Epirus was divided into the districts of Chaonia, Molossis, and Thesprotia, named after the most numerous and powerful of its ancient tribes. Its most remarkable places were: Dodona, with the ancient oracle of Jupiter; Canope and Butthrotum, with harbors, chiefly communicating with the port of Brundisium in southern Italy; Ambracia, the capital of King Pyrrhus and his descendants, on the gulf of the same name; and Nicopolis (city of victory), on the same gulf, founded by Octavianus Augustus, in commemoration of the battle of Actium, near the opposite shore. The Epirotes had their share in Grecian fame and history, though the other Greeks did not consider them as belonging to the Hellenic race. Pyrrhus or Neoptolemus, the son of Achilles, is mentioned as king of Epirus after the Trojan war. Olympias, the mother of Alexander the Great, was a princess of this country. But their most dis-

tinguished man was King Pyrrhus (295-272 B. C.), who, in spite of the remonstrances of his chief minister Cineas, destroyed his armies and ruined the state in brilliant campaigns against the Romans and others. Oppressed by Macedon, the Epirotes were delivered by their ancient enemies the Romans, but proved faithless to their deliverers, supporting against them both Antiochus the Great of Syria and Perseus of Macedon. They were subdued by Paulus Æmilius (168 B. C.), and cruelly chastised, numerous cities being destroyed, and 150,000 of the inhabitants sold into slavery. Epirus was now a province of Rome, and shared the fate of its eastern dependencies. In 1432 it was conquered by the Turks, from whom it was wrested in 1443 by the famous Scanderbeg, prince of Albania. On his death in 1467 it was reconquered by Mohammed II., and has since been ruled by Turkish pashas, among whom, in the early part of the present century, Ali of Janina distinguished himself by his crimes, talents, and revolts against the authority of the sultan. The insurrection of the Suliotas, in southern Epirus, ended in their own ruin. As volunteers they promoted the independence of Greece without achieving their own. The modern inhabitants are mostly Arnauts.

**EPISCOPAL CHURCH, Protestant**, an ecclesiastical body in the United States which derives its origin from the church of England. Previous to the American revolution members of the church of England were constantly settling in all parts of the colonies. In Maryland especially they were very numerous, and in 1692 they seem to have constituted a majority of the population sufficiently large to establish their religion as the religion of the colony. In accordance with the prevailing views in the mother church, they held to the necessity of the episcopal office in order to give validity to their ecclesiastical functions. But no bishop was provided for them until after the peace of 1783. Up to that time the Episcopal church in this country was under the oversight of the bishop of London, and American candidates for the ministry were under the necessity of crossing the Atlantic to obtain orders. Efforts had indeed been several times made in the old country to secure an episcopate in the colonies; but these efforts were always defeated by a two-fold influence, one growing out of political complications and animosities, and another a jealousy of episcopacy as associated with lordly titles and vast incomes. It is also affirmed that, especially in New England, a fear that if the colonial dependence of our country on the crown of England should be much longer perpetuated, the establishment of an episcopate like that in England would be inevitable, contributed much to the zeal which characterized the struggle for American independence. In this state of things, as was natural, when the war had actually broken out, some of the church of England people, and more especially those of the northern states, were opposed to

it, and became what were called tories; while others, and particularly those in the southern states, heartily espoused the cause. Washington himself was a church of England man before the revolution, and after the treaty of peace he remained and died in the communion of the Protestant Episcopal church. Mr. Duché, the first chaplain to congress, was a church of England clergyman; and Bishop White of Pennsylvania, the first presiding bishop, was from the start an ardent friend of American independence. As early as August, 1782, a plan had been proposed for a union and organization of "the church of England people" into an independent branch of the church of Christ. No organization, however, was completed till September, 1785; but before this the Episcopalians of Connecticut elected the Rev. Samuel Seabury, D. D., to be their bishop. Dr. Seabury, in consequence of some political obstacle to his getting ordination in England, was consecrated at Aberdeen, Nov. 14, 1784, by three Scottish bishops, Robert Kilgour, Arthur Petrie, and John Skinner. The general convention which met in 1785 made application to the English church for the consecration of bishops for the American church, in order to perpetuate the succession in the Anglican line. For this office Dr. William White of Pennsylvania and Dr. Samuel Provoost of New York had been designated and elected, each respectively by the parishes in the states to which they belonged. They were consecrated in the Lambeth palace chapel, Feb. 4, 1787; and on Sept. 19, 1790, James Madison of Virginia was in like manner consecrated for the American church in Virginia. In 1789 the general convention met, consisting of the then bishops and clerical and lay delegates from each of the states in which any diocesan organization had been effected. At this meeting a constitution and canons for the organization and government of the church as a branch of the catholic church of Christ were adopted. The English prayer book, as revised and adapted to the altered political circumstances of the country, was set forth to be used in all the congregations after Oct. 1, 1790, and it remains unchanged to the present day. In the alterations thus made in the English formularies, it is declared that "this church is far from intending to depart from the church of England in any essential point of doctrine, discipline, or worship, or further than local circumstances require." And it has been held by some, though by no means a majority, that in consequence of this declaration in the preface to the American prayer book, as well as on general principles, the Protestant Episcopal church in the United States retains all the common and canon law of the English church, except in so far as "if may have been deemed inapplicable by its local circumstances," referred to in the preface, or modified or repealed by express legislation. The Protestant Episcopal church in the United States retains from the church of England the Apostles' and

Nicene creeds, the XXXIX. articles, with a slight modification in reference to the connection of the civil government with the church, the catechism, the baptismal offices, and the ordinal. But for the communion office it has rather followed the Scotch than the English church in placing a prayer of consecration and invocation of the Holy Ghost upon the consecrated elements before the administration of them to the communicants, and has even added to the Scottish service a few words making still more unambiguous the eucharistical character of the sacrament. The American church has also stricken out from its form for visiting the sick the formula for private absolution; and in the exhortation preceding the administration of the holy communion, it has omitted the direct reference to and advice in favor of private confession to the priest, and absolution from him. In this revision of the offices Bishops Seabury and White were chiefly instrumental, and Bishop White has left his testimony to the harmony and agreement of views and feelings with which they cooperated in the performance of this task. In regard to the ministry, the theory usually held in the Protestant Episcopal church, like that in the English church, is, that in order to be a valid branch of the church of Christ it must have the Holy Scriptures and the ancient catholic creeds, and the ministry in an unbroken line of succession from the apostles, and in the exercise of lawful jurisdiction; that the Christians of any nation with these conditions constitute a national branch of the church of Christ, totally independent of the jurisdiction and authority of any foreign church or bishop, subject only under Christ to the authority of the universal church in general council assembled; and that as such they have jurisdiction over all their members, and authority in matters of faith to interpret and decide, and in matters of worship and discipline to legislate and ordain such rites and ceremonies as may seem most conducive to edification and godliness, provided they be not contrary to the Holy Scriptures. The Scriptures and the two ancient creeds, as already said, the Protestant Episcopal church has; the ministry also it has obtained, as shown above, from the English church, and preserves in accordance with the ecclesiastical canons and usages which have prevailed from the days of the apostles. Its right to lawful jurisdiction must stand on circumstances and facts peculiarly its own, and found in its history and condition. In the first place it was planted by members of the English church, and in what was then, and continued to be until the American colonies became an independent national sovereignty, a part of the English dominions. The settlers of Jamestown came, in the language of their charter, to "discover and to prosecute effectually the full possession of all such heathen lands as were not actually possessed by any Christian prince or people," and "to establish there both the do-

minion of the British crown and the jurisdiction of the English church, provided always that the statutes devised should be, as near as conveniently might, agreeable to the laws and policy of England, and not against the true Christian faith, as professed in the church of England." They remained a part of the English church so long as the colonies remained a part of the English dominions and dependencies. Holding with the English church that episcopal ordination is necessary to valid jurisdiction and the due administration of the sacraments, the Protestant Episcopal church has been compelled to decline communion with the various Protestant denominations in the country, as none of them have what she regards as a valid episcopate. She does, however, acknowledge the validity of the orders conferred in the Roman Catholic church, but disregards the claim set up by that church to jurisdiction within the United States. This would follow from the fact of her first institution in this country, being planted here not only before the Roman Catholics had made a permanent settlement, but by the English church, and in territory which it is claimed at that time belonged to its jurisdiction. In this state of facts the Protestant Episcopal church consistently regards the Roman Catholic clergy as schismatics, according to the ancient canons, just as is the case in England, where the pope has intruded bishops and priests within the lawful jurisdiction of the established church of the land.—The dioceses of the Protestant Episcopal church formerly corresponded in number and extent with the states. The division of the state dioceses began in 1835, when western New York was made a separate diocese. Since then the dioceses of Pittsburgh (1865), Albany (1868), Central New York (1868), Easton, Md. (1868), Long Island (1868), and Central Pennsylvania (1871) have been established; so that in 1873 the state of New York numbered five, Pennsylvania three, and Maryland two dioceses. The institution of provincial synods has been created for the common interests of the dioceses of one state. The church has missions in Africa, China, Japan, Greece, and Hayti. In 1873 it had 49 organized dioceses, two of which, western Africa and China and Japan, were outside of the United States, and five were missionary dioceses in the territories. In each diocese there is an organized convention, consisting of bishop, clergy, and lay delegates chosen by the people. These conventions meet annually, and provide for all the details of local and specific legislation. The dioceses are organized into a general convention, which meets once in three years. It consists of all the bishops in the actual exercise of episcopal jurisdiction, and of clerical and lay delegates, four of each order chosen from each diocese by its convention. They sit in two houses, and not only is the concurrence of both houses necessary for the passage of any canon or law of the church, but

also a concurrence in case it is asked of each of the three orders, bishops, priests, and laity, in order that any measure may become a law. The number of priests and deacons in 1873 was 2,938; parishes, 2,700; communicants, about 248,000. The income of the principal religious societies during the year 1872 was as follows: domestic committee of missions, \$168,252; foreign committee, \$110,732; American church missionary society, \$53,938; evangelical education society, \$40,008; Protestant Episcopal society for the promotion of evangelical knowledge, \$43,088; the society for the increase of the ministry, \$28,923. The contributions in money for church objects, over and above what was expended in erecting and repairing church edifices and in the support of the parochial clergy, amounted in 1872 to \$6,187,250 89. This sum was devoted mainly to the support of the poor, and in sustaining missions, diocesan, domestic, and foreign. In consequence of its total disconnection from the state and political complications, the Protestant Episcopal church has had a degree of unity, harmony, and peace unknown to the mother church in England; and its increase by a comparison of statistics shows a gain in numbers of 20 or 30 per cent. above the increase in the population of the country since the time of its organization.

**EPISCOPIUS**, Simon, a Dutch theologian, whose original name was Bischoop, born in Amsterdam in January, 1583, died there, April 4, 1643. He was educated at Leyden, receiving theological instructions from Gomar and Arminius; and his attachment to the Arminian system exposed him to the enmity of the then dominant Calvinistic party. In 1610 he became pastor in Bleiswick near Rotterdam, and in 1611 he was chosen one of six ministers who were to defend Arminianism in a conference appointed by the states general. In 1612 he was invited to fill the chair of theology at Leyden, which Gomar had just quitted. He now became the object of unceasing attacks, was accused of being a Socinian, and of having combined with the Catholics to ruin Protestantism; and the popular animosity, so easily excited in religious causes at that era, became directed against him and his family. In 1618 Episcopius with some of his friends presented himself before the synod of Dort, but they were not allowed to take part in it. The Arminian or Remonstrant clergymen were deposed, and as they refused to renounce for the future the performance of pastoral duties, they were banished by the aid of the government. Episcopius then retired to Antwerp, where he wrote his *Responsio ad duas Patris Waddingii Jesuitæ Epistolas*, and his celebrated *Confessio Fidei Remonstrantium*. On the renewal of the war between Spain and the Netherlands Episcopius took refuge in France, and resided chiefly at Paris, where he published several works. On the death of Prince Maurice in 1625, when more tolerant princi-

ples prevailed in Holland, he returned, preached at Rotterdam, and after 1634 taught theology in the new college established by his friends in Amsterdam. To Arminius belongs the distinction of having founded the sect, but Episcopius was the theologian who first skillfully developed its ideas. Besides his many controversial pieces, the most important of his writings is the *Institutiones Theologicae*. A collection of his works was published by Courcelles (2 vols. fol., Amsterdam, 1650).

**EPISTOLÆ OBSCURORUM VIRORUM** ("Letters of Obscure Men," the word *obscuri* being intended to mean at the same time ignorant and illiberal persons), a collection of satirical letters in dog Latin, published anonymously in 1515 and 1517, the first part at Hagenau, by the learned publisher Angst, the second at Basel by Froben, though Venice is named on the title page as the place of publication. These letters are conspicuous in the history of the reformation in Germany. At that time John Pfefferkorn, a converted Jew, and Jacob Hoogstraaten were foremost among those in Cologne who endeavored to keep down the light of independent thought developed by the study of the classics. A violent literary feud between them and the liberal thinkers, Reuchlin especially, caused the publication of the *Epistolæ*, a keen and caustic satire on the ignorance and perversity of the clergy. There was much uncertainty in regard to their authorship. Reuchlin, Erasmus, and Ulrich von Hutten were severally supposed to have been the authors. But careful investigation has shown that there was a large number of contributors, including Ulrich von Hutten, Hermann von dem Bussche, E. Hess, Peter Eberbach, Rhegius, Sommerfeld, Cæsarius, Pirkheimer, Wolfgang Angst, and Jakob Fuchs, for the first volume; and besides them, Hermann von Nuenen and F. Fischer for the second. The *Epistolæ* were prohibited by the pope in 1517, in consequence of which their popularity increased. The book has been frequently republished. The best editions are those of Frankfurt (1643), London in 12mo (no year given), that edited by Maittaire at London (1710), a new edition by Rotermund (Hamburg, 1827), another by Münch (Leipsic, 1827), and the latest by G. Böcking (Leipsic, 1858), which includes also a third volume, published for the first time in 1689. The satirical form of the *Epistolæ* has on several occasions been imitated by more modern authors. One of these imitations is the *Epistolæ Novæ Obscurorum Virorum*, which was published by Prof. Schwetschke (Halle, 1849) as a satire on the German parliament.

**EPITHELIUM** (Gr. *ἐπί*, upon, and *θήλη*, a nipple), the layer of cells lining the internal free surfaces of the body, continuous with the epidermis which covers the external surface of the skin. It arises from cells like the epidermis, which are developed and thrown off in the same manner in both structures; the epi-

thelium, however, serves for totally distinct purposes in the animal economy, as from the soft and moist surfaces covered by its cells are elaborated the various secretions of the body. A continuous layer of its cells may be traced the whole length of the alimentary canal, along the other mucous membranes into the glands and follicles, on the serous and synovial membranes, and the coats of the blood vessels and absorbents. The two principal among the numerous forms of epithelial cells are the tessellated or pavement epithelium, and the columnar epithelium. The tessellated epithelium lines the serous and synovial membranes, the blood vessels, the follicles of most of the cutaneous and mucous glands, and many parts of the mucous membranes; the cells are generally flattened and polygonal, forming by their contact a kind of pavement, and the number of layers is usually small. The columnar epithelium covers the mucous membrane of the alimentary canal, the larger ducts of the glands, the vas deferens, and the urethra; its cells are cylinders, arranged side by side, one end rest-



Cells of  
Pavement Epithelium.

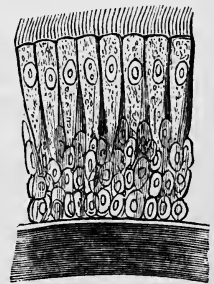

Ciliated  
Columnar Epithelium.

ing on the basement membrane, the other forming the free surface. These two kinds pass into each other at various points, giving rise to various transition forms, and both are often fringed with delicate filaments or cilia, varying in length from  $\frac{1}{1000}$  to  $\frac{1}{500}$  of an inch. (See **CILIA**.) Ciliated epithelium is found in the cerebral cavities, the ramifications of the bronchi, the air passages, with their nasal, frontal, maxillary, and lachrymal appendages, the posterior fauces, and Eustachian tube; their function seems to be to expel the secretions of these various membranes. The epithelial like the epidermic cells are in a state of continual separation and renewal, more rapid according to the activity of the connected function; the introduction of nutrient matters, the separation of efete substances, the various products of secretion, and the development of the reproductive particles, are effected by the agency of epithelium cells.

**EPIZOA** (Gr. *ἐπί*, upon, and *ζῷον*, an animal), a term used by Owen to signify only a singular class of humbly organized articulate animals, which infest the skin, gills, and eyes of marine animals, but now applied to the most

important of the external parasites of the animal kingdom. They all belong to the branch *articulata*, and to the classes *crustacea*, *arachnida*, and true *insecta*. Beginning with the first of these, we shall find that, like the entozoa, many of them possess limited powers of locomotion, and consequently must pass the whole term of their existence upon the animals they infest; but that as we ascend in the scale of organization, and come to the arachnida, and especially the insecta, there is no longer this dependence upon a fixed position for sustenance and habitation, and that, more independent of the will of others, they only make use of their hosts for accidental nourishment, or compel them to take charge of their young. We shall consider the most important of them in the order of this classification, referring for their anatomy and general description to the articles respectively devoted to these classes.

I. *Crustacea*. The parasitic representatives of this class are confined to the pœcilopodous entomostraca, and are found only upon marine animals, being in fact the substitutes for insects, which cannot live beneath the water. These are subdivided into the *lerneada* and the *siphonostoma*, which together formed Owen's class of epizoa. The former of these have for a long time puzzled the naturalist on account of their peculiar appearance. Aristotle and Pliny described them; Linnæus placed them among the mollusca; Lamarck removed them to the annelides; and Cuvier arranged them among his intestinal worms. Their forms are very various and fantastic, but they are mostly elongated, with tubular necks of a horny consistency, at the end of which is the mouth armed with sharp implements, by which they attach themselves to the eyes, gills, and flesh of fishes, and suck their blood. The females have long plumose appendages attached posteriorly, which are the ovaries. The males are imperfectly known. The young when first hatched are oval, and possess natatory limbs, by aid of which they seek their proper host, and which, when this object is accomplished, are either transformed by metamorphosis into grasping organs, or are lost. They are often found in great numbers attached to the same fish, and some are even 6 or 8 in. long. They occasionally excite even the largest sword or sun fish to such a state of desperation by the torments they inflict, that it dashes itself upon the beach. They inhabit both fresh and salt water. The *siphonostoma* are of a higher order. They have an oval, flattened body, which is partially protected by a hard shield or carapace, and are provided with three or four pairs of feet armed with sharp claws, by means of which, and sucking disks, they fix themselves to the skin of fishes, and soft parts of crustacea and other aquatic animals. Particular species generally infest particular fishes; and scarcely any fish is free from them. They move with considerable rapidity over the body of the fish, and may leave it for

another host. The *caligi*, of which as many as 40 have been removed from a single codfish, are generally found on weak or diseased fishes on the parietes of the mouth and bronchial cavities, but are unable to suck their blood. Fishermen call them fish lice. The *cyamus* is sometimes found in such numbers upon the whales of the southern ocean as to entirely strip them of their epidermis, and to produce a white color recognized at a considerable distance. None of the crustaceous parasites are ever found on terrestrial animals. II. *Arachnida*. In this class, nearly allied to the insects, we find a body divided into two principal parts, viz., cephalothorax and abdomen, and provided with four pairs of legs. The abdomen may be subdivided into several segments. The only parasites belonging to it are included in the order *acarina* or mites. These are minute animals, in which the head, thorax, and abdomen are blended in one oval mass. In their immature state they have three pairs of legs; the fourth they acquire later. Before taking up the true mites, we will describe briefly two genera which are found on man, viz.: *linguatuula* and *demodex*. The first, sometimes called *pentastomum*, has an elongated, cylindrical body, made up of alternate rings and constrictions, and is about half an inch long. Its head is armed with two large hooks resembling the thorn of a rose bush. It is found enclosed in cartilaginous or calcareous cysts on the surface of the liver in negroes. Another species (*L. ferox*) is now and then met with in *post mortem* examinations encysted on the surface of the liver of whites, but is oftener found in the frontal sinuses of herbivora and dogs. The *demodex folliculorum* bears also the generic names *acarus* and *steazon*, and is the pimple mite or dweller in the follicles of the human nose. As long ago as the middle of the 17th century it was known that an animal inhabited the comedo, a hard inflamed tubercle which appears on the forehead and skin, especially of young men; but not until 1842 was the subject investigated, by Henle and Simon at the same time. The head of this microscopic parasite is separated from its body by a half-moon-shaped constriction, and is furnished with a double-jointed papilla armed with sharp hooks or saws. The four pairs of legs are short, and consist of three joints which move with difficulty, and are tipped according to some au-



Skin Mite (*Demodex folliculorum*).

thorities with three claws, to others with but one. Several forms are met with owing to difference of age and sex. First we see one whose lizard-like tail is three times the length of the body; the contents of this extremity are dark and granular, consisting of fat globules. In an-



other form the shape is nearly the same, but the whole animal is smaller, and has but three pairs of legs; this is undoubtedly immature. Still a third presents itself with a body like that first described, but with a hinder extremity no longer than the body, and of a conical form, displaying transverse chitinous rings. It seems much more plausible to consider this the male, than to suppose that the tails of the former varieties drop off or shorten. No definite internal structure has yet been made out. Wedd and some other observers think they have made out within the body of the female, and in the field, immature forms without extremities; and if this be true, they are viviparous. They are found generally in the hair follicles of the nose of thick and fat-skinned persons, but may yet be met with on the breast or back, or wherever comedones occur, of which, when present in numbers, they may be the cause, although generally they occasion no trouble. They are usually found with their hinder extremity next the surface, and either close to the hair, or in the canals of the fat glands, upon the secretions of which they live. Their occurrence is very general, and to find them, we have only to squeeze the follicles on the sides of the nose between the finger nails, and to add to their contents beneath the microscope a drop of oil, by which the sebaceous matter is rendered clear. In the dead body they will be found much more deeply seated, as if they had sought warmth by penetrating toward the interior as the surface became cold. The *acar-us* or *sarcoptes scabiei*, or itch insect, will be fully considered in the article ITCR. Still other forms of acari or sarcoptes are sometimes met with on man, transferred to him from the beasts on which they live. Their occurrence is purely accidental, and they are never known to reproduce in such situations. The eruption they cause may be of long continuance, but only because fresh infection takes place by continued contact with the animals affected. The sarcoptes of the various domestic quadrupeds produce upon them the disease known as mange, and are specifically different. The mite of the cat and lion, however, resembles and is probably identical with that of man; so that it is a question whether these creatures got their itch first from man or *vice versa*. The parasite of the horse is large enough to be visible to the naked eye, and its mode of burrowing and of reproduction is nearly the same as that of the *sarcoptes hominis*. It produces a dry scaly appearance of the skin, which is sometimes called "scratches." The cheese and dried-fruit mites may likewise live for a short time on the skin, but cause nothing more than a passing irritation. The family of *ixodes*, or ticks, is also a great plague to man and beast. They live on moss and dry foliage, on sunny hillsides, and in groves and thickets, and never fail to attack grazing cattle and passers by. They bore into the skin with their sharp proboscis armed with horny barbs, and remain

hanging till the body, at first minute and flat, becomes swollen with blood, even to the size of a bean. To tear them away is impossible on account of their recurved barbs, and great caution and patience are necessary; for if violence is used, the head remains behind, and causes inflammation, which may last for months. Generally long and gentle rubbing with some essential oil will make them quit their hold voluntarily. They lay a vast number of eggs, and their multiplication upon oxen and horses is sometimes so great that the animals die of exhaustion. The *gamasida*, beetle lice, are other mites parasitic on birds, reptiles, and insects, and both land and water beetles are often found covered with them.

Bird Mite (*Dermanyssus avium*).

The *dermanyssus avium* abounds in great quantities in bird cages and hen houses, and lives upon the blood of their inhabitants. Numerous cases are on record of their presence in great numbers on persons who frequent such localities, penetrating and living beneath the epidermis. They produce the disease occasionally met with among the wretched and filthy sick of the poor, called *acariasis*. Colonies of mice are often infested with similar parasites. Another mite similar to the *ixodes* is the *leptus autumnalis* of Europe, which, living in grass or grain or upon fruit bushes, gets upon the reapers and passers by, and causes pustules and sores. It is red, whence the name of the disease, *rouget*. A similar parasite is the *bête rouge* of Martinique, which often renders necessary amputation of the sufferer's limbs.

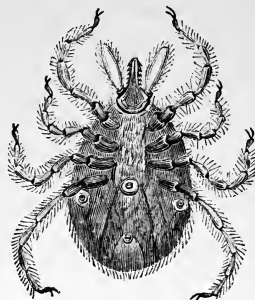
Red Mite (*Leptus autumnalis*).

III. *Insecta*. In this division we shall consider the parasitic insects of animals in order commencing with those of the mammalia. The human body serves as a residence for several of these, the best known and most numerous of which are the *pediculida*, or lice, which belong to the apterous *ametabola*, or wingless insects without metamorphosis. Four are peculiar to man: *Pediculus capitis*, *P. vestimenti*, *P. tabescentium*, and *phthirius pubis* or *inguinalis*. The head louse is grayish white, and it is supposed to adapt itself to the color of the hair of its host. The males are smaller and less numerous than the

females. The eggs, which are bean-shaped, cling to the hair as soon as laid, probably by means of some glutinous matter secreted by the female. After remaining as nits for 6 days, the young emerge, and at the end of 18 days more are capable of reproducing. Each

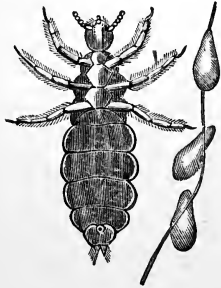

Head Louse  
(*Pediculus capitis*).

female can deposit 50 eggs in all. The presence of lice is easily detected, for we may see them with the naked eye, and their eggs attached to the ends of the hair cannot escape detection. Even when the old are at work beneath the disgusting disease they create, the females creep forth to deposit the nits upon the fine ends of the hair, perhaps because

too great heat is prejudicial. A mere itching is the first symptom of lice, which leads in simple cases to scratching and slight excoriations of the scalp. Let heads so infested remain for months uncombed and uncared for, and such cases will result as are often seen in European hospitals. A specimen is brought in with hair all matted together in flakes, and looking as if sand and molasses had been poured upon it and dried. The stench is loathsome and sickening. On raising the hair a frightful mass of filth, pus, scabs, and lice is visible. The scalp is found covered with crusts of blood, with open ulcerating sores, and with thick and elevated scabs, from beneath which on pressure pus flows freely. The ears, too, may be converted into a suppurating surface. The *P. vestimenti*, or body louse, is much larger than the preceding species. The head is longer, and its color dirty white. This animal is seldom if ever found on the body, but inhabits the seams and folds of clothing next the skin, where it deposits its eggs. Its bite causes the same itching as that of the *P. capitis*, but the results are different. The scratching brings on papules, which become excoriated, and eczema appears. The clothes adhere to the skin, which brings on exudation, and lastly pustules appear. In some cases constant scratching produces such a hyperæmia that a deposition of pigment follows sufficient to color the whole skin like that of the negro. The *P. tabescentium* of writers has longer antennæ and a larger and more distinctly separated thorax than the two preceding species, and an indistinctly ringed abdomen. It inhabits the skin itself, living in its fold beneath the epidermis, and produces the disease called *phthiriasis*. Leeuwenhoeck cultivated a colony on his own leg for a considerable time, and estimated that in eight weeks one female might become the grandmother of 5,000. But some of the best authorities deny the existence of any such

species. The *phthirius pubis* is considerably broader, and has a shorter posterior extremity, than its relatives. Its legs are long, and the hindmost two are armed with immense claws. It is very slow in its motion, and has no eyes. This species, as its name implies, is found most

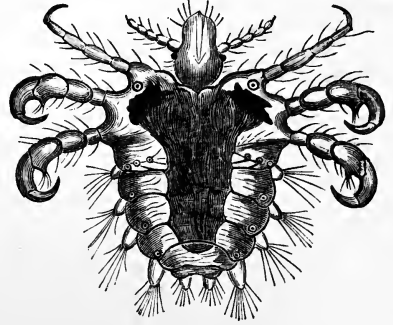

*Phthirius pubis*.

frequently on the pubes, but occasionally on the beard, eyebrows, and hair of the breast and axillæ, where it bites deeply into the skin, and lives upon the blood of its host. When present in numbers, these parasites cause an intolerable itching, and may be seen sticking firmly to the surface of the body like black specks of coal. Küchenmeister has found on the heads of an Egyptian mummy and a New Zealand savage nits whose claws differ somewhat in size from those of the ordinary species. Lice are a world-wide pest, and no nation seems free from them. According to Aristotle, they must have been a great plague among the ancients, and Aleman, Sulla, and Philip II. are reported to have died of them. But it is probable that some other parasite, as the mites, was confounded with them.—Rising a step higher among the insects, we come to the *hemimetabola*, or those with an incomplete metamorphosis. In the order *hemiptera* we find the

*cimex lectularius* or *acanthia lectularia*. The bed-bug has a small head, from which project two long three-jointed antennæ. Behind the compound eyes are two small transparent flaps covered with bristles, which are the rudiments of wings. The thorax is



Bedbug (*Cimex lectularius*).

broad and short, the abdominal segment very large, broad, and flat. The eggs are long and cylindrical, and are furnished with a stem, by which in the spring the female fixes them upon objects. It is of a reddish brown, and has a very disagreeable odor, which arises from two

glands that contain a red and granular matter. This pest inhabits the crevices of beds, walls, and furniture, or wherever it can find a convenient place to conceal itself by day. It will lodge in garments also, but always emerges at night to prey upon the blood of man. Its predatory excursions are not wholly confined to the night, for when present in the clothing it bites as well by day. The skin of some individuals seems quite insensible to their bite, while upon others it causes great local irritation. The black point seen in the centre of the spot is caused by the coagulation of the blood left in the wound. Sometimes a person is literally almost devoured by these creatures, and the whole body may be covered with the eruption they produce. They are found generally wherever man exists.—The flea (*pulex irritans*) belongs to the holometabolous *aphaniptera*, or hopping *diptera*, which undergo a complete metamorphosis. Its head is short and rounded. The eye is simple. The mouth is provided with two four-jointed palpi, with a long tongue protected above by a short double upper jaw, and a sort of upper double lip or taster, and below by a projecting under jaw. The thorax is provided with two pairs of stigmata, and with three pairs of legs, the first of which are seemingly on the head. The two hindermost are composed of many tarsal joints, which are very long, and furnish the means by which its enormous leaps are taken. They are provided also with long double claws. The posterior segment is covered with ten plates or rings lapping over each other, like shingles on a roof. The color of this parasite is a reddish brown. The male is smaller than the female, and its abdomen is flatter and broader. The eggs are oval, white, and covered with a glutinous matter. In six days after their deposition, either in dust or beneath the nails, small, worm-like, jointed larvæ without feet creep forth from them. In 11 days more they envelope themselves in a thin cocoon, from which at the expiration of 11 days they emerge perfect animals. It is a disputed point whether the males are parasitic; Küchenmeister argues from the structure of their head that they are not. Little need be said here about the habits of this insect, which in some countries, as Italy, Turkey, and Germany, is such an intolerable nuisance. It bites all the time, day and night, and is never satisfied. Its bite, though productive of more itching, does not cause the great irritation the *acanthia* produces. Their horny covering or mail protects them from being crushed except by a wonderful degree of pressure, and their alert senses enable them to avoid the hunter's hand, unless it be skilful and experienced. The *pulex penetrans*, or chigo, jigger, or sand flea, as it is variously

Flea (*Pulex irritans*).

called, is smaller than its relative, and has a proboscis longer than its body. (See CHIGO.) —The larvæ of several forms of insects are occasionally found either in or on some part of man; but as they are an accidental occurrence, they need only be alluded to here. The larvæ of some unknown *æstrus* are sometimes met with beneath the skin. They form pimples from which flows a moisture, while around them the skin is red and painful. Humboldt in his South American travels met Indians with large parts of their exposed bodies thus affected. In the intestinal canal the larvæ of *anthomyia scalaris* and *cunicularis* are sometimes found. The *musca vomitoria*, or blue-bottle, sometimes deposits its larvæ in open cavities of the body, as the ear, eye, or wherever else moisture and heat are found. The common flesh fly, *M. carnaria*, and the *M. domestica*, also deposit their eggs at times in hot weather either on open wounds or moist places of the body, and cause the appearance known as "live sores." The larvæ are sometimes deposited in a highly developed condition, so that they become maggots even in a few hours. Quadrupeds also are infested by lice, almost without exception each by one peculiar to itself, though sometimes one species is known to live upon several animals of the same genus. They increase with great rapidity upon such beasts as are kept in dirty stables, seldom cleaned, and poorly cared for, and most frequently are seen upon old horses. They cause irritation, roughness of skin, and loss of hair, in consequence of the disposition of their hosts to bite and rub the affected parts. Fleas abound upon several animals, and are nearly always distinct species. The most frequent and troublesome pests of the herbivora are various *æstri* (*gasterophilii*) or breeze flies. The *æstrus* peculiar to the horse, for instance, produces the well known disease called bots. (See BORS.) Another species, *Æ. ovis*, deposits its eggs in the nostrils of sheep, usually about half a dozen in each individual. The larvæ are soon hatched, and creep by means of their two anterior hooks upward into the frontal and maxillary sinuses. There they remain until ready to undergo metamorphosis, when they fall out, gain their wings, and repeat the process. The larvæ are composed of 12 segments besides the head. Sheep fear these flies greatly, and often huddle together with their heads close to the ground to avoid them. The symptoms of their presence are sneezing and a discharge of glairy mucus from the nostrils, but they seldom do serious injury. The *Æ. ovis* lays its eggs on the backs and sides of oxen and cows. The larvæ, hatched by the heat, penetrate the skin, and by increase of size form tumors as large as pigeon's eggs. They live upon the pus their presence produces. After a time they make a larger aperture, and, creeping out, seek a proper place in which to become chrysalids. The fly when discovered creates a great panic among cattle, and often

drives them frantic to the nearest pool. Birds, too, are nearly all infested by lice, each species generally supporting its own species of parasite, and sometimes more, which lives upon

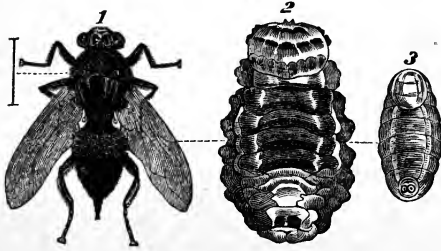

1. *Cestrus Bovis*. 2. Larva. 3. Chrysalis.

the feathers and blood of its host.—Insects also, fortunately, are made a dwelling place by other insects, and thus their rapid growth and the consequent destruction of vegetation held in check. *Ichneumon* is the name given to these unnatural parasites. They are small flies with slender bodies, and there are many species known, probably as many as of caterpillars and moths. The female deposits her eggs in the larva, pupa, or eggs of other insects and spiders. When she has found her proper host, a caterpillar for instance, she seizes it, and deposits her egg in the skin behind the head. The larva, soon emerging from the egg, eats its way along within the caterpillar, avoiding those parts essential to life, and by the time the latter has become a chrysalis the former is nearly mature. It lies quiet for a time to undergo metamorphosis, and awaking once again a perfect animal, bores its way out from the cocoon of its murdered host, and flies forth in quest of fresh victims. Thus it is that nature keeps in check its most destructive creatures by means so insignificant and unseen.—See Baird, "British Entomotraca" (Ray society, London, 1850); Brant and Katzeburg, *Medicinische Zoologie* (1833); Burmeister, "Manual of Entomology," translated by Shuckard (London, 1836), and *Genera Insectorum* (Berlin, 1833-'46); Newman, "History of Insects" (London, 1839); Westwood on "Insects" (2 vols., London, 1839), and bibliography therein contained; Denny, *Monographia Anoplurorum Britannia* (London, 1842); Siebold, "Anatomy of Invertebrata," translated by Burnett (Boston, 1854); Wedl's *Grundzüge der pathologischen Anatomie* (Vienna, 1854); and Küchenmeister, "Manual of Parasites," translated for the Sydenham society (London, 1857).

**EPSOM** (Sax. *Ebbsham*), a market town of Surrey, England, on the margin of Banstead downs, 13 m. S. W. of London; pop. in 1871, 6,276. At one time it promised to become a prominent watering place, in consequence of the discovery of medicinal springs impregnated with sulphate of magnesia, from which the celebrated Epsom salt was manufactured. The

springs are no longer visited, but the town has gained another attraction in the great annual races held during the week preceding Whitsuntide on the neighboring downs. They are attended by nearly 100,000 persons of every class of society, and the grand stand on the race course, erected in 1829-'30, will hold 7,500 persons. The chief excitement centres in the race for the Derby stakes, instituted in 1780, which takes place on Wednesday.

**EPSOM SALT**, the name given in pharmacy to the hydrated sulphate of magnesia, which was obtained as far back as the year 1675 by evaporating the waters of some mineral springs at Epsom, England. Sea water was afterward found to contain it, the brine remaining after the separation of the common salt consisting of the sulphate of magnesia and the chlorides of magnesium and calcium. It was readily obtained by collecting the first crystals which formed, and washing them with a strong solution of the same salt. An excellent quality is manufactured at Baltimore and Philadelphia, from the mineral magnesite, a silicious hydrate of magnesia, which is found in the serpentine of that region. The mineral, reduced to powder, is dissolved in sulphuric acid. The product after drying is calcined in order to decompose the sulphate of iron, and convert it into the peroxide of iron. It is then dissolved in water, and any iron present is precipitated by sulphuret of lime. The crystals of sulphate of magnesia are separated and dissolved again to complete their purification. This salt, and calcined magnesia also, have been prepared from the dolomite or magnesian carbonate of lime, by the process of Mr. William Henry of Manchester. The mineral was calcined, and the lime and magnesia were then converted into hydrates by sprinkling with water; the former was dissolved out by a minimum quantity of hydrochloric acid, and the latter was converted into a sulphate by sulphuric acid.—Epsom salt is also found as a mineral substance, incrusting the walls of caves, in the form of an efflorescence, and also in silky fibres. In the Mammoth cave, Kentucky, loose masses of it adhere to the roof like snow balls, and in many other caves of the western states it is found upon the walls or mixed with the earth upon the floor. It occurs in some of the gypsum quarries near Paris, and in other parts of France; and wherever water becomes charged with gypsum or sulphate of lime, and flows over rocks containing carbonate of magnesia, the sulphate of magnesia is likely to appear from the result of mutual decomposition of the two salts. Hydrated sulphate of magnesia consists of 1 equivalent of magnesia, 20; 1 of sulphuric acid, 40; and 7 of water, 63=123; or magnesia 16.26 per cent., acid 32.52, and water 51.22. It crystallizes in four-sided prisms with reversed dihedral summits, or four-sided pyramids, of hardness 2.25, and specific gravity 1.75. The crystals effloresce slightly in the air, and if

they contain any chloride of magnesium this is shown in their deliquescing. They dissolve in their own weight of water at 60°, and in three fourths their weight of boiling water. Sulphate of soda is sometimes fraudulently mixed with Epsom salt. Its presence may be detected by dissolving 100 grains in water, and precipitating with a boiling solution of carbonate of potash. Unless this precipitate of carbonate of magnesia amounts when dried to 34 grains, sulphate of soda is no doubt present.—The salt is much used as a cathartic, and, being mild and cooling, is particularly adapted to the treatment of fevers and inflammatory affections. The medium dose is an ounce, and this is said to be deprived of its bitter taste, and rendered quite palatable, by being dissolved in about a pint of water, and boiled a few minutes with 1½ grain of tannic acid or 2 or 3 drams of roasted coffee, strained, and sweetened with sugar. If given in small doses and frequently repeated, its action may be directed to the kidneys rather than to the bowels; and the same happens if for any cause, as for instance intestinal obstruction, it fails to be excreted in the usual manner. The value and activity of many of the celebrated mineral waters of this country and Europe depend upon the Epsom salts or Glauber salts which they contain. The laxative action of sulphate of magnesia is increased by freely diluting it with water. An ounce dissolved in a quart of water will act upon the bowels much more decidedly than the same quantity dissolved in half a pint. This fact serves to explain partly the action of certain natural laxative waters.

**EQUATOR** (Lat. *æquare*, to make equal), an imaginary circle drawn around any symmetrical solid of revolution (for example, a sphere or an ellipsoid) so that all its points are equally distant from the extremities of the axis of revolution. These extremities are called poles. Thus the earth is an ellipsoid revolving about an axis the extremities of which are called the north and south poles; a circle conceived to be drawn around the earth so that all its points are equally distant from the poles is called a terrestrial equator.—The celestial equator, or as it is often called by astronomers the equinoctial, is a great circle of the celestial sphere, situated in the indefinite extension of the plane of the terrestrial equator. All its points are equally distant from the poles of the celestial sphere. The name takes its origin from the fact that when the sun in his annual course passes through the plane of the celestial equator the days and nights are equal in all parts of the world. This occurs about the 21st of March and the 23d of September in each year, which periods are hence called respectively the vernal and the autumnal equinox; and the points where the plane in which the sun moves intersects the celestial equator are called the equinoctial points. The celestial meridian which passes through these points is called the equinoctial colure.

**EQUINOX.** See EQUATOR.

**EQUITES** (plural of the Lat. *æques*, horseman), or knights, an order of the people in ancient Rome, which in some respects may be compared with the English gentry. Their origin is attributed by Roman historians to the institution of Romulus, who is said to have selected the first 300 out of the three chief divisions of the patricians, and to have divided them into three centuries, named Ramnenses, Titienses, and Lucernes, corresponding to similar names of the three patrician tribes. Tarquin the Elder added three new patrician centuries, and Servius Tullus 12 new ones from among the richest plebeians. They formed a regular military body, being obliged to serve on horseback in time of war, and were divided into *turmæ* of 30 men each, subdivided into tens. They were also called *celeræ*, and their chiefs *tribuni celerum*. Politically they seem to have represented an aristocracy of wealth in opposition to the aristocracy of birth, particularly after they became a distinct body of the people by the institutions of Servius Tullius. Under the republic the knights were enrolled by the censors and consuls for a service of five years, being supplied by the state with a large sum for the purchase, equipment, and maintenance of a horse, but with no personal pay. Every dictator, immediately after his appointment by the senate, had to select a commander of the horse, called *magister equitum*. During service they had no votes in the assemblies of the centuries. At the time of the siege of Veii, when the want of cavalry was much felt by the Romans, a new body was added to the ancient knighthood, consisting of a large number of young volunteers who offered to enter the ranks at their own expense. The new knights received regular pay, but had no vote, and no share in many distinctions enjoyed by the old order. Gradually they coalesced into a numerous and wealthy middle class, placed politically and socially between the patricians and plebeians, and were so recognized by a law of Caius Gracchus (123 B. C.). Of the privileges as jurymen which the same laws bestowed upon them, they were deprived by Sulla. At that period they were generally the farmers of the public revenues, under the name of *publicani*, and as such seem to have been despised by the Roman people. Under the empire, owing to the heterogeneous elements of which their increased body was composed, they gradually sank, and in spite of efforts to restore their influence they disappeared from political life under the later emperors. In general the history of the Roman knighthood, as a political institution, is involved in great obscurity.

**EQUITY**, in a general sense, natural right, but as used in jurisprudence an administration of law with reference to the particular circumstances of a case, in contradistinction to the ordinary method of adjudicating by a rule of general application. This is a theoretical rather than a practical view, for equity as dis-

tinguished from strict law is necessarily administered by uniform rules. A judgment founded upon the particular circumstances of a case, without any reference to principles applying in common to such case and to others, would hardly deserve the name of a judicial decision, but rather would be an arbitrary opinion unregulated by legal analogy. This has never been the nature of equity as administered in any country where laws have been prescribed for the regulation of society. At an early period, it is true, many cases would occur which were not provided for by legislation. In these a discretion must be exercised; but every case when decided becomes a precedent, and thus in time the equitable or exceptional law acquires a systematic form and obligation. Another class of cases is where a positive law is productive of some individual hardship not contemplated in the enacting of the law. Relief may then be afforded by the intervention of an equitable power, whose office is not to abrogate or interfere with the operation of the law according to its real intent, but to afford exemption in cases which were probably not foreseen, and therefore could not have been intended. Again, there may be an omission in a law, whether it be statutory or derived from custom, to provide for cases of non-compliance by reason of casualty or some cause not involving serious fault. Thus where forfeitures or penalties are consequent upon the failure of strict performance of an agreement, there is an obvious distinction between intentional neglect and accidental failure, especially if in the latter case it was by inevitable misfortune. There is here room for equitable relief in the one case without impairing the operation of the law in the other, to which alone it justly applies. It is indeed difficult to distinguish with exact precision the line that divides culpable negligence from excusable omission, or to determine how far actual disability should be a ground of relief from legal obligation. Where no fraud is involved, the obligation of contracts cannot as a general rule be abrogated by a court of equity. Hardship will sometimes occur, and there is a natural impulse to give relief in the individual case; but such leniency often repeated is found to be productive of counterbalancing consequences not at first anticipated, and the necessity of a general rule becomes apparent. The discretionary power of the Roman prætor was at first unrestricted, but it was early brought under certain rules from which he was not allowed to depart. It is true that annually when each prætor went into office he made a formal publication of the rules by which he would be governed in his administration of the laws during his term of office, which might allow the inference that he had an arbitrary liberty to disregard former precedents; but practically it was but the adoption of the edict of his predecessors, with occasional modifications suggested by enlarging experience.—The English equity system was early

dissevered from the ordinary administration of law, and has ever since remained separate. Yet the equitable principles maintained in the court of chancery could have been applied by the common-law courts, and to some extent the latter have been compelled to admit modifications into their practice by analogy to equitable proceedings. Thus the penalty of a bond was formerly held to be the debt, and to be recoverable; yet after the court of chancery gave relief upon the payment of the real debt, which was usually specified in the condition of the bond, the common-law courts gave the same relief at any time before judgment; though if payment of the amount really due was not prior to that time tendered, judgment could be entered for the penalty and enforced by execution for the whole amount. A similar change has also taken place with regard to mortgages. (See MORTGAGE.) Again, the conveyance of lands to uses became a peculiar subject of equity jurisdiction; the use not being recognized at law, but being enforced in chancery. The statute of uses (27 Henry VIII.) was intended to make the use cognizable as the real title in courts of common law, but this effect was defeated by the over-nice scruple of the judges, whereby a limitation of a second use (as when a conveyance was made to A for the use of B, in trust for C) was held not to be within the statute; and the court of chancery again intervened to enforce such second use under the name of a trust, and has ever since retained exclusive jurisdiction of that class of cases in England. Another peculiarity of the English equity system was formerly the right of calling upon the defendant in the action to testify, first by a sworn answer to the complaint, and then by examination upon accounting, and in various other cases, at the election of the complainant. But this distinction has been superseded by the recent statutory provisions in England and most of the United States, by which parties are made competent witnesses in all the courts. (See EVIDENCE, and also CHANCERY.)

**EQUITY OF REDEMPTION.** See MORTGAGE.

**EQUIVALENT, Chemical.** When an element enters into chemical combination with another element, it does so in a fixed proportion which may be expressed in numbers. This ratio is termed the combining equivalent, combining proportion, equivalent weight, or simply the equivalent of the element. The term atomic weight is also used synonymously by those who accept the atomic theory. The numbers in the annexed table of equivalents (64) were prepared in 1872 for the use of the students of the school of mines of Columbia college, by Prof. Charles F. Chandler. For convenience of reference both the old and the new equivalents are given. (See ATOMIC THEORY.) The perissads are printed in Italics, and the artriads in Roman. To convert formulas of the old system into the new, double the atoms of the old perissads, or halve the atoms of the ar-

tiads, and *vice versa*. Hydrogen is adopted as the unit:

ELEMENTS.	Symbols.	EQUIVALENTS.	
		Old.	New.
Aluminum	Al.	18·7	27·4
Antimony	Sb.	122	122
Arsenic	As.	75	75
Barium	Ba.	68·5	137
Bismuth	Bi.	210	210
Boron	B.	11	11
Bromine	Br.	80	80
Cadmium	Cd.	56	112
Cæstum	Cs.	133	133
Calcium	Ca.	20	40
Carbon	C.	6	12
Cerium	Ce.	45·7	81·4
Chlorine	Cl.	35·5	35·5
Chromium	Cr.	26·1	52·2
Cobalt	Co.	30	60
Columbium	Cb.	94	94
Copper	Cu.	31·7	63·4
Didymium	D.	47·5	95
Erbium	E.	56·3	112·6
Fluorine	F.	19	19
Glucium	Gl.	4·6	9·2
Gold	Au.	197	197
Hydrogen	H.	1	1
Indium	In.	56·7	113·4
Iodine	I.	127	127
Iridium	Ir.	99	198
Iron	Fe.	23	56
Lanthanum	La.	46	92
Lead	Pb.	103·5	207
Lithium	Li.	7	7
Magnesium	Mg.	12	24
Manganese	Mn.	27·5	55
Mercury	Hg.	100	200
Molybdenum	Mo.	43	96
Nickel	Ni.	29	58
Nitrogen	N.	14	14
Osmium	Os.	100	200
Oxygen	O.	8	16
Palladium	Pd.	53	106
Phosphorus	P.	31	31
Platinum	Pt.	98·7	197·4
Potassium	K.	39·1	78·2
Rhodium	Rh.	52	104
Rubidium	Rb.	85·4	170·8
Ruthenium	Ru.	52	104
Selenium	Se.	39·5	79
Silicon	Si.	14	28
Silver	Ag.	108	108
Sodium	Na.	23	23
Strontium	Sr.	44	88
Sulphur	S.	16	32
Tantalum	Ta.	182	182
Tellurium	Te.	64	128
Terbium	Tb.	37·7	75·4
Thallium	Tl.	204	204
Thorium	Th.	59·2	118·4
Th.	Sn.	59	118
Titanium	Ti.	25	50
Tungsten	W.	92	184
Uranium	U.	60	120
Vanadium	V.	51·3	51·3
Yttrium	Y.	30·8	61·6
Zinc	Zn.	32·5	65
Zirconium	Zr.	44·8	89·6

tity by weight of each element which unites with one equivalent of oxygen to form a protoxide, analogous to water, is usually considered to represent its equivalent. A knowledge of the exact weights of the equivalents is of the first importance to chemists; all calculations regarding the composition of bodies, as in analysis, or of the quantities of materials to be employed in the manufacture of compounds, being based upon them. As the equivalent numbers express nothing but the relative weights in which the elements unite with each other, it is evident that the weight of any one equivalent may be arbitrarily chosen as a standard to which all the others shall be referred; it is essential only that the relation be strictly observed. Tables of equivalents are thus constructed, in which the equivalent weight of each of the elements is attached to its name. Several standards have been selected, but only two have ever been generally used. The equivalent weight of hydrogen, being smaller than that of any other element, was regarded as unity by Dalton, who referred all the other equivalents to it. This system has been generally adopted by the chemists of Great Britain and the United States. It possesses the very great advantage that in it the equivalents are represented by small numbers, many of them without fractions, which are convenient in calculations, and can be easily retained by the memory. Another table, in which the equivalent weight of oxygen is assumed to be 100, has been much used on the continent of Europe. It was proposed by Berzelius, mainly it would seem for the purpose of discountenancing a theory advanced by Prout, that all the equivalent numbers are simple multiples of that of hydrogen; superiority was claimed for it on the ground that as oxygen is the most abundant of all the elements, and as the greater number of bodies studied by chemists are compounds of it, calculations would be simplified if its equivalents were regarded as equal to 100; in which case it is only necessary to add 100, 200, 300, &c., to the equivalent weight of the element with which oxygen is combined, in order to ascertain the equivalent weights of its several oxides. The equivalent of sulphur, a very common element, would also have a simple expression, being equal to 200. But these instances do not at all compensate for the high numbers by which the other equivalents must be represented; numbers which cannot be remembered without great difficulty, and which render even the most common calculations extremely laborious unless logarithms are resorted to. Berzelius, who believed that the equivalent numbers should be regarded as entirely accidental and unconnected with each other, desiring to give them the most accurate expression possible, introduced the custom of attaching to them large decimal fractions; indeed, the power to do this which is afforded by the high numbers of his system has always been claimed as one of its advantages. The

Each element has its own special combining equivalent, and is incapable of uniting with other elements except in this proportion or some multiple of it. The equivalents of compound bodies are represented by the sums of the equivalent numbers of all the elements which enter into their composition. The weights of the equivalents of the elements are ascertained by determining experimentally how much of each is required to replace the others in their combinations with some well known element, the weight of the equivalent of which has been assumed. Thus, the quan-

accuracy of thus employing several decimals, in cases where the process by which the result has been obtained is liable to errors of considerable magnitude, was long since pointed out by Erdmann, who called attention to the fact that no greater or lesser number of decimals ought to be given than the experiment justifies. All tables of equivalents heretofore published are more or less defective from neglect of this truth. The equivalent numbers have been thoroughly investigated and revised by Dumas, who has again brought forward and upheld Prout's theory, which, owing to the vigorous opposition of Berzelius, had found but few supporters of late years. Most of the equivalents thus far studied by Dumas are simple multiples of that of hydrogen. To this rule there are, however, several exceptions; among which some are multiples of one half, while others are multiples of one quarter of an equivalent of hydrogen. It is still a subject of discussion whether the equivalents of several of the elements should not be regarded as twice, or that of others as one half of those ordinarily admitted. This change would greatly simplify certain portions of chemical science, and many chemists habitually employ equivalents thus modified.

**ÉRARD, Sébastien**, a French manufacturer of musical instruments, born in Strasburg, April 5, 1752, died in Passy near Paris, Aug. 5, 1831. He went to Paris at the age of 16, and apprenticed himself to a maker of harpsichords. He soon acquired great reputation for skill, was dismissed by his master from jealousy, had a workshop fitted up for him in the hotel of the duchess de Villeroi, and here in 1780 constructed his first pianoforte, an instrument which, though invented a number of years previously, and in use in Germany and England, was then almost unknown in France. In connection with his brother Jean Baptiste, he soon after established a manufactory of pianofortes in Paris, which gradually became the first in Europe. During the revolutionary period the brothers Éradard went to England, and established a manufactory of pianos and harps in London; but in 1796 Sébastien returned to Paris. He constructed the first grand pianos with single action ever made in Paris; in 1808 he much improved the mechanism of the instrument, and in 1823 completed his inventions in this department by the production of his grand piano with repeating movement. Among his many other inventions was his celebrated double-action harp. The celebrity which his instruments gained remains undiminished, and Éradard pianos are still unsurpassed for roundness, fulness, and beauty of tone.—He was succeeded in the firm by his nephew JEAN BAPTISTE ORRUÉE PIERRE, born in Paris in 1794, died in Passy, Aug. 3, 1855. He possessed much of the inventive skill of his uncle; published in 1849 *Notice sur les pianos d'Éradard en Espagne, en Italie, en Suisse, en Russie, &c.*; and rebuilt in 1850 the organ constructed by Sébastien

Éradard in the Tuileries, which had been destroyed during the revolution of 1830. His death is said to have been caused by grief at the injury done to his estate at Passy by the construction of a railway.

**ERASMUS, Desiderius**, a Dutch theological and classical scholar and writer, born in Rotterdam, Oct. 28, 1467, died in Basel, July 12, 1536. He was the natural son of Gerard Praet and Margaret, the daughter of a physician of Sevenbergen. He himself received the name of Gerard, but afterward assumed its Latin synonyme Desiderius, the Greek translation of which (Ἐράσμιος) furnished his surname. He was sent first to the school of Gouda, and afterward to the cathedral at Utrecht to become one of the choir boys. At the age of nine he was transferred to the monastic school at Deventer, where he studied the classics. In 1480 both his parents died, and his tutors sent him to the school of Romboldus at Bois-le-Duc, that he might fit himself for the priesthood. For some years he resisted their wishes, and neglected the studies which they arranged for him; but in 1486 he was persuaded by a friend who had just come back from Italy to embrace a life so free from excitement and so favorable to study, and entered the convent of Stein near Gouda. The discipline was not strict. Erasmus was allowed to study other than theological treatises, and his reputation as a classical scholar was soon widely spread. In 1492 he was selected as a companion by the bishop of Cambrai, and was ordained to the priesthood. Erasmus remained with his patron at Cambrai five years, when he went to study at the college of Montaigu in Paris, where he supported himself by taking pupils. His studies were interrupted by serious sickness, which left in him the seeds of a malady from which he suffered all the rest of his life. Among his numerous pupils was a young English nobleman, William Blomt, Lord Montjoy, by whom he was promised a pension of 100 crowns if he would take up his residence in England. His two years' stay in that country was made pleasant by the attentions of the nobility and the friendship of the most eminent English scholars. He was presented at court, studied at Cambridge and Oxford, became the associate of More and Colet, and acquired a thorough knowledge of Greek. For several years after his return from England he led an unsettled life, teaching in various cities of France and Holland, translating the ancient classics, investigating the text of the Scriptures, and increasing his acquaintance with the scholars of Europe. In 1505 he again visited England, and received from Cambridge the degree of bachelor in theology. The presents received in England made it possible for him to visit Italy, where his stay lasted nearly three years. At Turin the degree of doctor of theology was conferred upon him. In Venice he resided with the famous printer Aldus Manutius while his collection of "Adages" was in press. In Rome



he was treated with great regard by Pope Julius II., who gave him a dispensation from his monastic vows. Shortly after the accession of Henry VIII. he returned to England. On the journey thither he composed his *Moriae Encomium*, "Praise of Folly," in many respects his most remarkable work. On his arrival he was received by his friend More, was presented with a living by the archbishop of Canterbury, which he resigned for a pension of £20, and accepted professorships of theology and Greek at Cambridge. In 1514 he returned to the continent at the invitation of the archduke Charles, afterward Charles V., from whom he received the appointment of councillor, with a small salary. This sinecure allowed him to reside where he chose, and he afterward employed his time almost wholly with literary pursuits, correspondence, theological, polemical, and satirical writing, and with editions and translations of many of the less known Greek and Roman classics. With Reuchlin, his only rival as a linguist, he carried on a spirited controversy concerning Greek pronunciation; and the theory which he maintained has until the present century been generally received in the schools of Europe. With Luther his dispute was still sharper. The monk of Wittenberg was at first a warm friend and admirer of the great scholar; but finding that Erasmus was not ready to adopt the extreme tenets of the reformers, he at first expostulated with, then ridiculed, and then denounced his former friend as a time-server, a coward, and a foe to true religion. Erasmus was equally unfriendly to the monastic habits and to the subtleties of the scholastic divinity, and exercised his wit on both of these; but he had no love for theological quarrels, and no wish to draw upon himself unpopularity or persecution. He welcomed the reformation as a movement of free thought, but deprecated its excesses. He disliked all dogmatism, as well as all extravagance in religious rhetoric, and would have the reformers confine themselves to the open vices of the monks and clergy, leaving aside the possible errors in doctrine. His middle course in regard to the reformation brought upon him the censure of zealots in both parties. In 1521 he had taken up his residence in Basel, where he was presently called on to mediate between the Catholic magistrates and the rising Protestant party. His moderate counsels satisfied neither side. The insurrection of February, 1529, completed the overthrow of the authorities; the Roman Catholic religion was definitely prohibited in the city, and all who had opposed the new doctrine were compelled to depart. Though Erasmus had already been condemned as a heretic by the college of the Sorbonne, he could not endure the society of the men in power, and went to Freiburg, where he remained from 1529 to 1535. In vain did the Catholic party try to win him back to full communion, and in vain did the reformers attack him by jest and sar-

casms. He answered the libels of Goldenhauer by pungent rejoinders, he evaded the summons to the diet at Augsburg, and his "Retractions," though promised, were never published. He declined more than one tempting offer, and, while he was not unwilling to accept additions to his scanty income, did not care to obscure his literary fame by the more imposing dignity of a place in the sacred college. In 1535 he returned to Basel, where an attack of gout compelled him to remain, and where he died in the arms of his friends. His last days were cheered by the friendly visits and messages of distinguished men both of the Protestant and of the Catholic party. His death was lamented as a public calamity; a long procession of magistrates and students followed his funeral; and the bequest of his whole property to the aged, the poor, and the orphan seemed to justify the monument which was erected to him in the cathedral at Basel, and which still remains the chief object of interest in that edifice.—Erasmus was small in stature, with light hair and light blue eyes. His portrait by Holbein represents his look as sickly and his face as thin and wrinkled. He was fond of luxurious living, but unable from physical weakness to gratify his appetites. His timidity was excessive. He dreaded to stay in the neighborhood of any contagious disease, and, in spite of his rationalistic tendencies, was frequently haunted by superstitious fears. He had a fine native humor, a keen enjoyment of witty discourse, and an accurate eye for every form of beauty. His taste was as refined as his knowledge was prodigious. He was versed in all the studies of his age; in most of them he excelled. His reading was various, but not desultory. His treatises were finished productions, and their style is always clear, flowing, and eloquent. Erasmus aided the reformation rather as a scholar and critic than as a thinker or reasoner. He exposed the abuses of the convents and the inconsistencies of the scholastic theology, but he produced no new creed and argued in favor of no heretical doctrine. His defence of the right of reason against authority was weak and evasive. But he revived the study of the Scriptures in their original tongue, affirmed the superior value of early Christian testimonies, and gave an impulse to Biblical and patristic investigations. He was the most gifted and industrious pioneer of modern scholarship.—Erasmus published in 1516 the first printed edition of the Greek Testament from manuscripts, which has been regarded as his greatest work. His complete works, with a biography, were published after his death by Beatus Rhenanus (9 vols. fol., Basel, 1540-'41). Another more complete edition was published at Leyden by Le Clerc (10 vols. fol., 1703-'6). Of the *Colloquia*, his most famous work, a great number of editions have been published; the best is that of Amsterdam (1650). The *Moriae Encomium* also passed through a great number of editions; it was

translated into German and illustrated by Holbein; the latest edition is that of Havre (1839). His other most important works are the *Copia Verborum*; the *Adagiorum Collectanea*; the treatise *De Libero Arbitrio*, which was answered by Luther; the *Paraclesis*, an exhortation to the study of Christian philosophy; the volume of *Epigrammata*; the *Antibarbarorum Liber*; *Lingua*, a satirical work; an explanation of the Apostles' creed; *Ecclésiasta, sive de Ratione Concinnandi*, in 4 books; and the immense collection of "Epistles," which show the character of the man. Of his purely classical works, there are editions of Seneca, Suetonius, Aurelius Victor, Ammianus Marcellinus, Eutropius, Quintus Curtius, Cicero *De Officiis*, the "Tusculan Questions," Pliny the Elder, Livy, and Terence, who was his favorite among the Latins, as Plutarch and Lucian were among the Greeks. He also published translations from Xenophon, Isocrates, Euripides, and Libanius, and issued editions of Ptolemy, Demosthenes, and Aristotle. Among his works are also many controversial apologies, Scriptural expositions, and liturgical treatises. The life of Erasmus has been written by Beatus Rhenanus, Melchior Adam, Merula, Scrivierius, and Gaye, in Latin; by Henke and Müller in German; by Lévesque de Burigny, Bayle, Bullart, and Nisard, in French; and by Jortin, Knight, Charles Butler, and R. B. Drummond (2 vols., London, 1873), in English. See also *Érasme, prédécesseur et initiateur de l'esprit moderne*, by Durand de Laur (2 vols., Paris, 1872).

**ERASTUS, Thomas**, a Swiss physician and theological polemic, who exchanged his original name of Lieber for its Greek equivalent, born in Baden, Sept. 7, 1524, died in Basel, Dec. 31, 1583. He studied theology and literature in Basel and medicine in Bologna, practised his profession with success, and after being for many years professor of physic at Heidelberg, obtained in 1580 the chair of ethics at Basel. A skilful practitioner, relying on induction from experience rather than on dogmas and theories, he was a formidable opponent of the fancies of Paracelsus and his disciples. His principal theological controversies were in the conferences of Lutheran and reformed divines at Heidelberg and Maulbronn on the Lord's supper, in which he maintained that the reference to the body and blood is figurative. He also had a controversy with Dathenus and Beza concerning the doctrine of excommunication. He held that ecclesiastical censures should extend only to divergences in the theological opinion, and not at all to vices and immorality, which were civil offences, and properly punishable only by temporal magistrates. In some of his writings he seems to favor the principle that all ecclesiastical authority is subordinate to the civil power, which is the doctrine commonly recognized as Erastianism. His treatise *De Cæna Domini* (1565) was translated by Shute (London, 1578); his theses on excommunication, written in 1568, were first published in

1589 by Castelvetro, who married his widow. An English translation of his theses was published in 1669, and was reëdited by the Rev. Robert Lee (London, 1845).

**ERATH**, a N. E. central county of Texas, watered by affluents of the Brazos river; area, 1,000 sq. m.; pop. in 1870, 1,801, of whom 89 were colored. The surface is generally undulating, with some eminences on the S. and N. E. borders. The soil in the valleys is excellent; the uplands are less fertile, but afford good pasturage. Timber of various kinds covers about one third of the surface. The chief productions in 1870 were 9,931 bushels of wheat, 78,109 of Indian corn, 6,533 of oats, and 167 bales of cotton. There were 1,703 horses, 57,609 cattle, 2,312 sheep, and 7,935 swine. Capital, Stephenville.

**ERATO** (Gr. Ἐρατώ, the lovely), one of the nine muses, daughters of Jupiter and Mnemosyne. In the theogony of Hesiod she holds the sixth place among them. She was the protectress of nuptial ceremonies, and the muse of erotic poetry. She disputed with Mercury the honor of having invented the lyre.

**ERATOSTHENES**, a Greek astronomer, geometer, geographer, poet, and philosopher, born in Cyrene about 276 B. C., died about 196. He was variously named by his contemporaries the "cosmographer," the "measurer of the universe," the "second Plato," and the "pentathlete" or victor in five contests. He had for masters Ariston the philosopher, Lysanias the grammarian, and Callimachus the poet, and he completed his education in Athens. Ptolemy III. invited him to Alexandria and intrusted to his care the renowned library of that city. He is said to have died of voluntary starvation, to which he was led by regret for the loss of his sight. His most important work, the *Γεωγραφικά*, treated of the nature and form of the earth, which he supposed to be a motionless globe, of its magnitude, and of its countries, towns, lakes, rivers, and mountains. He was the founder of geodesy, and was the first to compute the magnitude of the earth by the astronomical method still in use. He is supposed to have suggested the construction of the large *armillæ*, or fixed circular instruments, which were long in use in Alexandria. He devised a method for discovering the prime numbers, and resolved the problem of the duplication of the cube. Among his works was one of universal chronology, the fragments of which form the basis of the system adopted by Bunsen in his work on Egypt. He also wrote verses on numerous scientific subjects, a commentary on the astronomical poem of Aratus, and treatises on comedy and on the Homeric poems. A number of other works are attributed to him upon doubtful grounds. Only a few brief fragments of his writings remain; but Strabo and other later writers made great use of his geographical works.

**ERBIUM**, a metal supposed by Mosander to exist, together with terbium and yttrium, in

the mineral gadolinite of Ytterby in Sweden. Mosander in 1843, while examining the crude yttria obtained from gadolinite according to the method of Berzelius, came to the conclusion that there was a mixture of three earths of different basic power; these he named, in the order of their bases, erbia, terbia, and yttria. Subsequent investigations of different chemists have thrown considerable doubt on the existence of terbium. Bahr and Bunsen separate erbia and yttria by precipitating with oxalic acid, treating with potassium sulphate, converting into nitrates, dissolving, and repeatedly crystallizing; nitrate of erbium is ultimately obtained, containing no appreciable quantity of yttrium. Erbium oxide, prepared by ignition of the nitrate or oxalate, is a faint rose-red powder, and glows with an intense green light at high temperatures, which in the spectroscope exhibits a continuous spectrum intersected by a number of bright bands. Solutions of erbium salts give an absorption spectrum exhibiting dark bands. The salts of erbium have a rose-red color, and closely resemble in taste and reactions the compounds of yttrium. The atomic weight of erbium is 112.6. The metal has never been isolated.

**ERCILLA Y ZUÑIGA, Alonso de**, a Spanish poet, born in Madrid, Aug. 7, 1533, died about 1594. He was a scion of an ancient Biscayan family, and after the death of his father, Fortunio Garcia, who was a member of the council of Charles V., he resided at the imperial court, where he was educated as one of the pages of the prince of Asturias, afterward Philip II. He accompanied him on his travels abroad, and went with him to England in 1554, when Philip married Queen Mary. About this time the Araucanians in Chili, whose territory had been invaded by the Spaniards in 1537, rose against them, and many Spanish knights then at the English court volunteered to serve in the war. Ercilla joined this expedition, distinguished himself, and in an interval of the war was involved in a duel during a tournament which was held in Imperial, a city of Araucania, in honor of the accession of Philip II. to the throne. The combatants were both sentenced to death, and it was not without difficulty that Ercilla's sentence was commuted to imprisonment. In 1562 he returned to Spain, in 1570 married Maria de Bazan, and was employed on different missions by Philip II. His literary fame rests upon *La Araucana*, the most celebrated of Spanish epics. It is in 37 cantos, and celebrates the war with the Araucanians, in which the poet himself was engaged. Ercilla wrote the first and best part of this poem on the battle field, but left it unfinished. The first 15 cantos were published in Madrid in 1569, the second part of the poem in 1578, and the third part in 1590. A continuation of the poem in 33 cantos, written by Osorio, appeared in 1597. The best editions of the *Araucana* are those of Madrid, 1776 and 1828.

**ERCKMANN-CHATRIAN**, the joint name of two French novelists, who have been collaborators for many years. ÉMILE ERCKMANN was born in Pfalzburg, then in the department of Meurthe, Lorraine, May 20, 1822; ALEXANDRE CHATRIAN, in Soldatenthal, a forest hamlet near Abreschviller, in the same department, Dec. 18, 1826. The father of the former was a bookseller, that of the latter a glass founder, the descendant of one of the Italian families brought into France by Colbert to introduce the glass manufacture. Erckmann was placed as a boarder in the communal college of Pfalzburg, whence he went in 1842 to Paris to study law. Chatrian, destined by his parents for the business of his ancestors, was sent in 1844 into Belgium, where he soon obtained a good position in the glass works; but, unable to overcome his taste for letters, he returned to Pfalzburg against the wishes of his family, and took the position of an usher in the communal college, where he also had studied for a short time. In 1847 he made the acquaintance of Erckmann, who had been obliged to return to Pfalzburg by illness. From this time their history is common. Erckmann had published previously an *Essai sur le remplacement militaire* (8vo, Paris, 1844), but Chatrian had not yet appeared as a writer. In 1848, after the revolution of February, they went to Paris, Erckmann to continue his legal studies, Chatrian to take a situation in the office of the Eastern railway. In the same year they made their first joint literary venture, furnishing to the *Démocrate du Rhin* a number of short stories, *Le sacrifice d'Abraham*, *Le bourgmestre en bouteille*, &c., most of which have since been collected and published in book form. They wrote also for the *Ambigu Comique* a drama entitled *Le chasseur des ruines*, which was accepted on condition of certain changes, which they refused to make. Another play, *L'Alsace* in 1814, was brought out at the Strasbourg theatre, but was suppressed by the prefect on its second representation. During the following years they contributed numerous novelettes and serial stories to different publications, exhibiting in their work such a unity of conception and of style that the public remained ignorant of its double origin; but they failed to make any remarkable impression and almost despaired of success. Erckmann continued his studies in a desultory way, giving most of his attention to literature, and did not pass his last legal examination till 1858, Chatrian meanwhile remaining in the railway office. In 1859 the publication of *L'illustré docteur Mathéus* made a change in their fortunes, and their joint names became familiar to the world. Thenceforward they devoted themselves to literature, and many novels, published at regular intervals, exhibit an assiduous and successful collaboration almost unparalleled. Their works strongly reflect the manners and customs of their native region, giving patient and minute photographs of Lotharingian and Alsatian peasant life, and

picturesque descriptions of the scenes familiar to them. The pleasures of Parisian life have never weaned them from the love of their country, and they are said to have built up in the heart of Paris a little Pfalzburg, where they cherish the customs and foster the traditions of their native home. They are strong republicans, and their later writings breathe a spirit which has done much to disabuse the French people of their love for imperialism. Their principal works, besides those already mentioned, are: *Contes fantastiques* (1860); *Contes de la montagne* (1860); *Maître Daniel Rock* (1861); *Contes des bords du Rhin* (1862); *L'invasion, ou le fou Yégoïf* (1862); *Le joueur de clarinette, &c.* (1863); *Madame Thérèse* (1863); *L'ami Fritz* (1864); *Histoire d'un conscrit de 1813* (1864); *Waterloo* (1865); *Histoire d'un homme du peuple* (1865); *La maison forestière* (1866); *La guerre* (1866); *Le blocus* (1867); *Histoire d'un paysan* (1868); *Le Juif polonais*, a play successfully brought out at the theatre of Cluny (1869); *Le plébiscite* (1872); and *Les deux frères* (1873). Many of these stories have been translated in England and the United States. *Le plébiscite* appeared in England in 1872 under the title "The Story of the Plébiscite, related by one of the 7,500,000 who voted 'Yes,'" and in this country as "A Miller's Story of the War" (1872).

**ERDMANN, Johann Eduard**, a German philosopher, born at Molmar, Livonia, June 13, 1805. He studied theology at the university of Dorpat, afterward attended the lectures of Schleiermacher and Hegel at Berlin for two years, and returning in 1828 to his native place, became pastor and first preacher there. In 1832 he again went to Berlin, and in 1836 was appointed professor of philosophy at Halle. He has published numerous works on psychology, logic, and metaphysics, dreams, the history of philosophy, &c. The most important is *Versuch einer wissenschaftlichen Darstellung der Geschichte der neuern Philosophie* (3 vols., Leipzig, 1834-'51).

**ERDMANN, Otto Linné**, a German chemist, born in Dresden, April 11, 1804, died in Leipsic, Oct. 9, 1869. He was professor at the university of Leipsic from 1830 till his death. He was particularly famous as the founder of Erdmann's *Journal für praktische Chemie* (1834), to which he contributed numerous valuable articles. The laboratory established by him in Leipsic was in its day one of the best in Germany, and he was one of the most successful and popular teachers in Europe. He published several books, including *Lehrbuch der Chemie* and *Grundriss der Waarenkunde*, which passed through many editions. He devoted much time to the chemical analysis of indigo and other dyestuffs, and his writings embodying the results of his investigations are not only useful to men of science, but also to merchants.

**EREBUS**, one of the oldest gods of the Greeks and Romans, son of Chaos and Night. He was changed into a river, into which he had been

precipitated for having assisted the Titans. The term Erebus was frequently applied to a portion of the pagan inferno, a dark and gloomy space beneath the earth, through which the souls of the just passed on their way to enjoy the eternal and delightful life of Elysium.

**ERECHTHEUS**, or *Erichthonius*, a fabulous hero of Attica, or according to some later writers the name of two persons, one the grandson of the other. Homer describes Erechtheus as an autochthon and king of Athens, and the son of Gæa (Earth); he was educated by Minerva. The one whom Apollodorus mentions under this name was the son of Vulcan and Athhis. Minerva, who reared him secretly, gave him in a chest to Pandrosos and her sisters, who, opening it from curiosity, saw in it a serpent, were seized with madness, and threw themselves down the Acropolis or into the sea. Having expelled Amphictyon, he became king of Attica, established the festival of the Panathenæa, and founded on the Acropolis the temple which after him was called the Erechtheum. By his wife Pasithea he was the father of Pandion. He is said to have decided the dispute between Minerva and Neptune for the possession of Attica in favor of the goddess, and to have introduced the use of chariots with four horses, for which he was set among the stars as Auriga. The myths connected with the life of the second Erechtheus, the son of Pandion by Zeuxippe, are the Eleusinian war, the sacrifice of one of his daughters, and the suicide of the three others in consequence of a response of the oracle, and his being killed by Jupiter with a flash of lightning at the request of Neptune. The Erechtheus of Diodorus came from Egypt to Athens with grain in time of famine, was made king, and established the Eleusinian festivals. Another Erechtheus, the son of Dardanus and father of Tros in Ilium, is fabled as the richest of mortals, in whose fields grazed 3,000 beautiful mares.

**EREGLI**, or *Erekli* (anc. *Heraclæa*), a seaport town of Asia Minor, in the vilayet of Kastamuni, on the Black sea, 128 m. E. by N. of Constantinople; pop. about 5,000. It has a good harbor, and exports timber, silk, wax, linen, and coal, in exchange for colonial produce, tobacco, and iron. Ship building is carried on to some extent. A few traces are found here of the ancient Heraclæa, which was one of the principal towns of Bithynia. Near by is a coal field extending for about 80 m. E. and W. along the shore of the Black sea, and 5 or 6 m. inland. The coal mines are worked under the direction of English engineers, yielding large supplies for steamers and gas works at Constantinople.—There are two other towns of the same name: one in the vilayet and 90 m. E. S. E. of the city of Konieh, in Asiatic, and the other in the vilayet of Edirneh (Adrianople), 55 m. W. of Constantinople, in European Turkey. The latter has a harbor on the sea of Marmora, and is the see of a Greek bishop.

**EREMACAUSIS** (Gr. *ἐρημος*, gentle, and *καύσις*, combustion), a term applied by Liebig to the gradual oxidation or slow combustion of organic compounds, vegetable and animal, which takes place in the presence of atmospheric oxygen and water. It is allied to fermentation and putrefaction, and is convertible into the latter by limiting the access of air. Eremacausis is accompanied by the evolution of heat, which is generally only slightly manifested in consequence of the slowness of chemical action. When, however, large masses are undergoing decay, sufficient heat may be developed to create active combustion. The temperature most conducive to eremacausis is about 60° F., and never below 32°. Moisture is a necessary condition, perfect dryness always completely arresting the process. Light is often produced by eremacausis in the form of phosphorescence, a phenomenon observed in decaying stumps and trunks of trees, and in animal flesh under favorable conditions. The explanation of this is still a matter of doubt, although modern science offers a solution in the fact that molecular vibrations may be created which are capable of communicating undulations of light unaccompanied by those of heat. The chemistry of eremacausis was carefully studied by Liebig several years ago, and although some of his views have been somewhat modified, they form with the investigations of De Saussure the basis of most of the knowledge we have upon the subject. The decay of wood is the most familiar example of the process, in which the hydrogen of the wood becomes more rapidly oxidized than its carbon, causing the formation of a brown powder called humus or ulmine, a substance which contains a much greater proportion of carbon than woody fibre. The action of oxygen on organic bodies at common temperatures and with free access of air is somewhat analogous to that which obtains when the temperature is raised with limited access of air. It is well known that in the latter case the oxygen unites with other elements than the carbon; also that the oxygen, hydrogen, and whatever nitrogen may be contained in the organic body, separate to a certain extent from the carbon and form new compounds, leaving a portion or nearly the whole of it in a free state, as in the manufacture of charcoal, and the production of coke in the retorts of gas works. In eremacausis, however, there is a union of carbon and oxygen, forming carbonic acid, and also of hydrogen and oxygen, forming water; but the latter process being much more rapid, the remaining portion of the decomposing body becomes richer in carbon, and gradually converted into humus, which substance continues to oxidize, becoming at last completely converted into carbonic acid and water. The nitrogen of the organic body passes into ammonia and into nitrous and nitric acids, and it is supposed that there is also a portion of atmospheric nitrogen absorbed and converted into the same substances. When

nitric acid is formed it combines with the alkaline and earthy constituents of the vegetable juices, forming nitrates. According to Kühlmann, ammonia may also be transformed into nitric acid when the access of air is small; and in this way the nitre in the caves of Zeilan and in the grottoes on the banks of the Seine, and also in cellars, has been accounted for. Fungi are plentifully developed during slow decay, appropriating considerable nitrogen, often more than is contained in the decaying body, but whether directly from the air or through the intervention of other chemical processes, which is probable, is uncertain. Whatever combination takes place between the carbon of the decaying body and the oxygen of the air is also probably not direct, the gas being first absorbed by moisture, and then delivered to the elective affinity of the constituents of the woody fibre. Eremacausis is retarded or completely arrested by all those substances which prevent fermentation or putrefaction, such as creosote, carbolic acid, the mineral acids, and salts of mercury, copper, and other metals. Pasteur, who contends that fermentation and putrefaction are processes carried on by living organisms, adduces a number of experiments which he regards as proving that eremacausis also never takes place except by the influence of certain lower organisms.

**ERETRIA**, an ancient city of the island of Eubœa, situated a few miles S. E. of Chalcis, whose rival it was in commerce. It was founded prior to the Trojan war, and became rich, powerful, and one of the chief maritime states of Greece. It was early engaged in disputes with the Chalcians, and for having given assistance to the Ionic cities of Asia in their revolt from Persia it was razed to the ground by the Persians in 490 B. C. It was soon rebuilt S. of the old site, and took part in the Peloponnesian war. The philosopher Menedemus, a disciple of Plato, here established a celebrated school of philosophy. The ruins of the city are still visible.

**ERFURT**, a city of Prussia, in the province of Saxony, capital of an administrative district of the same name, midway between Gotha and Weimar, 145 m. S. W. of Berlin; pop. in 1871, 43,616. It was formerly a city of considerable importance, having at the end of the 16th century nearly 60,000 inhabitants. It is a fortress of the second class, and derives great strategic importance from its situation on the military high road of central Europe. Erfurt contains nine Lutheran and eight Roman Catholic churches, a synagogue, a deaf and dumb asylum, and several schools. The cathedral, a fine Gothic structure, which had suffered much from war, has been well restored within the present century. It contains one of the most massive bells of Germany, weighing 275 cwt. and dated 1447, called Maria Gloriosa, and in popular parlance Grosse Susanna, this having been the name of the bell melted during the fire in 1251. The finest modern churches are the Barfüsserkerche and the Augustinerkerche.

The most interesting religious building of Erfurt is the Augustinian convent, in which Luther lived for several years. It is now called the Martinsstift, and is used as an asylum for orphans and for other charitable purposes. The university, opened in 1392, once the fourth



Cathedral of Erfurt.

in Germany, was suppressed in 1816. The royal academy of popular sciences is remarkable for its extensive library.—Erfurt was ceded to Prussia by the peace of Lunéville in 1801; was taken by the French in 1806; was annexed to Westphalia in 1807; and was transferred by Napoleon to the duke of Saxe-Weimar in 1808. The congress of Erfurt (Sept. 27 to Oct. 14, 1808) was attended by Napoleon, Alexander of Russia, and the kings of Bavaria, Saxony, Württemberg, and Westphalia. In 1813 the town was taken by the Prussians, after a destructive bombardment. From Nov. 24, 1848, to Aug. 4, 1849, it was placed in a state of siege; and in March and April, 1850, the *Unionsparlament* of North Germany, convened by Frederick William IV., was held there in the church of St. Augustine.

**ERGOT** (Fr. a spur, as of a cock), a protuberance which grows out in a curved form resembling a cock's spur from among the grains of the plants of the *graminaceæ*, or grass tribe, as wheat, barley, and especially-rye. As it is most commonly met with in the last, the substance has been known by the name of spurred rye (*secale cornutum*). Some have thought it to be the seed altered by a diseased

growth, caused by the attack of an insect, or by unfavorable circumstances of moisture, heat, &c. De Candolle thought it a fungus occupying the place of the seed, and called it *sclerotium clavus*. But the evidences are now generally regarded as conclusive of its being the grain itself, diseased and deformed by the influence of a parasitic fungus, attached to it from its earliest development. This fungus, distinguishable by the microscope, has been detected in other parts of the plant; and the white dust or *sporidia* on the surface of the ergot will engender the disease in other plants if scattered in the soil at their roots or applied to the grains.—Ergot as collected for medicinal purposes is in solid grains from  $\frac{1}{4}$  to  $1\frac{1}{2}$  in. long, of cellular structure, the cells containing oily particles. Its aqueous infusion is claret-colored, has an acid reaction, and possesses the peculiar properties of the substance. Ergot contains a volatile alkaloid, *secalia*, supposed to be identical with *propylamia* obtained from herring pickle. The fixed oil, which at one time was supposed to partially represent the active principles of ergot, probably owed its properties to an incomplete separation from the other constituents. The so-called *ergotine* is not a definite chemical principle, but an extract. Ergot is used in medicine to promote the contractions of the uterus either during and after labor, or when independently of pregnancy it is desired to expel any morbid contents. The frequent or routine use of ergot to hasten labor or to expel the placenta is much to be deprecated as productive of danger, in the latter case to the mother, in the former to



1. Ear of Rye with Ergot (Spurred Rye). 2. The Ergot. 3. Diseased Grains of Rye.

both mother and child. Although promoting uterine action, ergot cannot be relied upon for this purpose at all times. Its action has been shown to extend to other organs possessing smooth muscular fibres similar to those of the uterus, and it has accordingly been used to

produce contraction of the blood vessels, as in hæmoptysis, hæmatemesis, aneurism, varix, and congestion of the spinal cord and brain. It is probably by this action upon the blood vessels that the epidemics of ergotism, from the use of diseased grains as food, have occurred in different parts of Europe. Ergotism assumes two forms, spasmodic and gangrenous, and probably requires for its production not only the poisonous action of ergot, but the additional depressing influences of cold, moisture, and insufficient food; a combination which is likely to take place in seasons favorable to the growth of the fungus.—Ergot may be administered in substance, infusion, decoction, fluid extract, or tincture. The dose for a woman in labor is about 20 grains of the substance repeated every 20 minutes till its physiological action is obtained; for other purposes, the dose is from 3 to 10 grains, according to the result sought for. It is apt to deteriorate by keeping, and therefore should be freshly prepared when used. A drop of the fluid extract is intended to represent a grain of the substance. The tincture is a little weaker.

**ERIC IX.** (according to some historians, VIII.), king of Sweden, called after his death St. Eric, the son of "a good and wealthy yeoman" (in the words of an old Swedish chronicle) named Jedward, died May 18, 1160. His mother was Cecilia, sister of a former king. His wife was Christina, also of royal blood. He was elected to the throne of the Upper Swedes, or as it was called the "royal chair of Upsal," in 1150. With a view to the spread of Christianity he undertook in 1157 a crusade against the heathen of Finland, and by transplanting Swedish colonists thither laid the foundation of the conquest of that country. On his return to Upsal he was attacked by a Danish prince, Magnus Henrikson, and in the battle that followed, at East Aras (modern Upsal), he fell covered with wounds. His virtues and the austerity of his life procured him the reputation of a saint; but he was never canonized. His rule, which at first extended only over Sweden proper (or Upper Sweden), after the death of King Swerker in 1155 also embraced Gothland (Lower Sweden). The effigy of St. Eric is preserved upon the arms of the city of Stockholm; and his remains are in the cathedral of Upsal.

**ERIC XIV.**, king of Sweden, the son and successor of Gustavus Vasa, born Dec. 13, 1533, died Feb. 26, 1577. In youth he was distinguished for his handsome person, his intelligence, and numerous accomplishments; but his passionate and suspicious disposition and immoderate indulgence in pleasure early awakened the apprehensions of his father. Toward his brothers, John, Magnus, and Charles, who had been created dukes of Finland, East Gothland, and Södermanland, he was always jealous and hostile. He succeeded to the throne in 1560, inheriting the good will of his people, a full treasury, and a prosperous

and happy kingdom, and inaugurated his reign by expending what seemed to the Swedes incredible sums on the festivals and pageants attending his coronation. Gustavus shortly before his death had made overtures of marriage to Elizabeth of England in behalf of his son, who, besides keeping alive these negotiations, opened similar ones with Mary queen of Scots, the princess Renée of Lorraine, and the princess of Hesse. But he married Katrina Mansdotter, the daughter of a corporal of his guards, whose beauty attracted his notice as she was selling fruits in the market place of Stockholm. Katrina seems to have been sincerely attached to Eric, and remained true to him amid all his misfortunes. In the beginning of his reign he displayed considerable executive ability, and made several judicious reforms in the civil and ecclesiastical government of the kingdom. He was a patron of science and art, and was the first to introduce the titles of baron and count into Sweden. During nearly his whole reign he was engaged in wars with Denmark and Poland, in the course of which the Swedes acquired from the latter country the Baltic provinces of Livonia and Revel, although at great cost of men and money, whole provinces having been depopulated to supply the army. The animosity of the king toward his brothers increased with years, and finally led to violent measures. John, who had married Catharine, daughter of Sigismund I., king of Poland, without Eric's consent, was besieged in his castle at Abo, and condemned to an imprisonment of four years, and the others were in constant fear of their lives. Assassination became frequent, and under the influence of the royal favorite, Göran Pehrsson, some of the oldest nobility, including the Sture family, were put to death. In the midst of these excesses Eric was attacked by madness, the effect of remorse, and for several days wandered alone in the forest. His brothers John and Charles at length rose in rebellion, and besieged Eric in Stockholm, who after some resistance capitulated, Sept. 30, 1568. He was deposed by the Swedish diet, and after languishing more than eight years in prison was poisoned by order of his brother John, who had succeeded to the throne.

**ERICSSON, John**, a Swedish engineer and physicist, born in the province of Wermeland in 1803. In 1814 he was appointed a cadet in the engineers, and in 1816 was employed as a leveller on the grand ship canal between the Baltic and the North sea. In 1820 he entered the Swedish army as an ensign, was soon promoted to a lieutenantcy, and was employed in surveys in northern Sweden, attaining the rank of captain. In 1826 he visited England, with the view of introducing his invention of a flame engine; but with mineral fuel it proved a failure. Soon afterward he resigned his commission and devoted himself to mechanical pursuits. Numerous inventions followed, among others the steam boiler on the principle of artificial draft, which was extensively adopt-

ed in London for manufacturing purposes, effecting a great saving of fuel, and dispensing with the huge smoke stacks; and it was adapted to railway locomotion on the Liverpool and Manchester railway in the fall of 1829. The directors had offered a prize for the best locomotive engine, and the lightest and fastest engine exhibited on this occasion was the Novelty, which, guided by its inventor Ericsson, started off at the rate of 50 miles an hour. The principle of artificial draft is still retained in all locomotive engines; but a different mode of producing it was accidentally discovered so soon after the display of the Novelty, that the original inventor derived no advantage from it. The lightness and compactness of this boiler led to many new applications of steam, and among others to Ericsson's construction of a steam fire engine, which was entirely successful. He constructed a similar engine of greater power for the king of Prussia. For this invention he received the prize medal of the mechanics' institute of New York. In 1833 he reduced to practice his long cherished project of a caloric engine, and submitted the result to the scientific world in London. The invention excited very general interest, lectures were delivered in explanation and illustration of its principle by Dr. Lardner and by Professor Faraday, and it was highly approved by Dr. Andrew Ure and Sir James Phillips. In 1836 he successfully applied the propeller to purposes of navigation; but failing to impress the British admiralty with the value of his invention, in 1839 he came to New York. In 1841 he was employed in the construction of the ship of war Princeton, which was the first steamship ever built with the propelling machinery under the water line and out of the reach of shot. The Princeton was distinguished for numerous mechanical novelties besides the propeller; among which were a direct-acting steam engine of great simplicity, the sliding telescope chimney, and gun carriages with machinery for checking the recoil of the gun. In the United States division of the London industrial exhibition in 1851, Ericsson exhibited the distance instrument, for measuring distances at sea; the hydrostatic gauge for measuring the volume of fluids under pressure; the reciprocating fluid meter for measuring the quantity of water which passes through pipes during definite periods; the alarm barometer; the pyrometer, intended as a standard measure of temperature from the freezing point of water up to the melting point of iron; a rotary fluid meter, the principle of which is the measurement of fluids by the velocity with which they pass through apertures of definite dimensions; and a sea lead, contrived for taking soundings at sea without rounding the vessel to the wind, and independently of the length of the lead line. For these he received the prize medal of the exhibition. In 1852 he brought out a new form of caloric engine in the ship Ericsson. It propelled this ship of 2,000 tons from

New York to Alexandria on the Potomac, in very rough weather, in the latter part of February, 1853. On this trip the engines were in operation for 73 hours without being stopped for a moment, and without requiring the slightest adjustment, the consumption of fuel being only five tons in 24 hours; but her speed was not great enough, and the caloric engines were subsequently replaced by steam engines. For several years Ericsson devoted himself to the improvement and perfection of the caloric engine and its application to pumping, printing, hoisting, grinding, sawing, turning light machinery of various kinds, working telegraphic instruments and sewing machines, and propelling boats. (See CALORIC ENGINE.) At the commencement of the civil war he entered into contract with the government for the construction of iron war vessels with revolving turrets for the guns, the first practical application of the principle. The first one, the Monitor, was completed in 100 days, reached Hampton Roads on the evening of March 8, 1862, and on the following day defeated and blockaded the confederate iron-clad Merrimack. Considerable improvements were made by him in the vessels (called monitors from the name of the first one) subsequently built. He has since devoted much attention to the construction of solar engines.—His brother NILS, born Jan. 31, 1802, served in the Swedish army, and from 1858 to 1863 in the navy. He was director of Swedish railways, constructed the canal between the Saiman and the gulf of Finland, the docks of Stockholm, and other public works, and was ennobled. He died in Stockholm Sept. 8, 1870.

**ERIDANUS**, the Greek name of a large northern river which Æschylus confounded with the Rhodanus (Rhône), but which later writers made identical with the Roman Padus, or modern Po, the chief river of North Italy. According to Hesiod and the tragic poets, Phaëthon, in a futile attempt to guide the chariot of his father Helios, was struck with a thunderbolt by Jupiter, and fell into this river. His sisters, the Heliadae, were changed into poplar trees, and their tears into amber, for which this river was chiefly famous. The name was also given to a river of Attica, which flowed into the Ilissus near Athens.

**ERIE**. I. A W. county of New York, bordering on Lake Erie, bounded N. by the Tonawanda and S. by the Cattaraugus creek; area, about 950 sq. m.; pop. in 1870, 178,699. It is drained and supplied with water power by Buffalo creek and several other small streams. In the N. part the surface is undulating, and the soil well adapted to grain; in the S. it is hilly, and here the land is more suitable for grazing. Iron ore, limestone, brick clay, and water cement are found in considerable quantities. The county is traversed by several railroads, and by the Erie canal, which connects with Niagara river at Black Rock, and has its terminus at Buffalo. The chief produc-



tions in 1870 were 436,193 bushels of wheat, 58,283 of rye, 346,128 of Indian corn, 1,125,339 of oats, 246,551 of barley, 21,804 of buckwheat, 643,932 of potatoes, 143,683 tons of hay, 503,073 lbs. of cheese, 2,149,358 of butter, 158,353 of wool, and 83,015 of hops. There were 16,154 horses, 40,323 milch cows, 17,016 other cattle, 33,324 sheep, and 17,043 swine. There were 1,429 manufactories; capital employed, \$13,043,790; value of products, \$27,446,683. The most important of these were 13 of agricultural implements, 8 of boats, 18 of boots and shoes, 70 of wagons, 87 of clothing, 45 of furniture, 1 of gas, 38 of iron and products of iron, 9 of dressed skins, 23 of machinery, 16 of malt, 8 of soap and candles, 55 of tin, copper, and sheet-iron ware, 19 planing mills, 63 saw mills, 4 distilleries, 42 breweries, 23 tanneries, 14 currying establishments, and 36 flour mills. Capital, Buffalo. **II.** A county of Pennsylvania, forming the N. W. extremity of the state, bordering on New York, Ohio, and Lake Erie; area, 740 sq. m.; pop. in 1870, 65,973. With the exception of a high ridge, several miles from the lake, and running nearly parallel with its shore, the surface is generally rolling and well watered. The soil is clayey, and in the N. part produces good crops of grain. The S. portions are mainly occupied by pasture lands. It is traversed by the Erie and Pittsburgh, the Lake Shore, the Philadelphia and Erie, the Oil Creek and Alleghany River, the Atlantic and Great Western, and the Buffalo, Corry, and Pittsburgh railroads; also by the Beaver and Erie canal. The chief productions in 1870 were 308,315 bushels of wheat, 531,584 of Indian corn, 743,106 of oats, 100,014 of barley, 27,464 of buckwheat, 415,989 of potatoes, 90,551 tons of hay, 165,739 lbs. of cheese, 1,896,701 of butter, and 170,825 of wool. There were 11,117 horses, 20,140 milch cows, 16,781 other cattle, 40,746 sheep, and 11,364 swine. There were 928 manufactories, with an aggregate capital of \$5,717,993. The principal establishments were 19 flour mills, 15 iron works, 20 tanneries, 9 currying establishments, 14 breweries, 14 planing mills, 56 saw mills, 9 manufactories of agricultural implements, 6 of boots and shoes, 15 of bricks, 45 of carriages and wagons, 1 of cars, 5 of rectified coal oil, 20 of barrels and casks, 9 of machinery, 9 of pumps, 12 of sashes, doors, and blinds, 29 of tin, copper, and sheet-iron ware, 3 of wooden ware, 1 of wood work, and 8 of woollen goods. Capital, Erie. **III.** A N. county of Ohio, bordering on Lake Erie and Sandusky bay; area, 250 sq. m.; pop. in 1870, 28,188. It is drained by Huron and Vermilion rivers. Near Huron river are several ancient mounds and enclosures, and at Sandusky are extensive quarries of valuable limestone. The surface is generally level, the soil alluvial and exceedingly fertile. It is traversed by the Cincinnati, Sandusky, and Cleveland, the Sandusky, Mansfield, and Newark, and its Huron branch, and the Lake Shore and Michi-

gan Southern railroads. The chief productions in 1870 were 239,874 bushels of wheat, 550,026 of Indian corn, 307,089 of oats, 22,865 of barley, 259,960 of potatoes, 19,523 tons of hay, 339,958 lbs. of butter, 169,905 of wool, and 54,701 gallons of wine. There were 4,813 horses, 4,700 milch cows, 3,527 other cattle, 39,751 sheep, and 7,863 swine; 2 manufactories of cars, 20 of barrels and casks, 2 of cutlery and edge tools, 13 of cured fish, 2 of hubs and wagon material, 2 of iron castings, 5 of machinery, 1 of printing paper, 3 of sashes, doors, and blinds, 10 of tin ware, 7 of cigars, 4 establishments for turning and carving wood, 15 for ship building, 2 for pork packing, 7 saw mills, 6 flour mills, 4 breweries, and 33 manufactories of wine. Capital, Sandusky.

**ERIE**, a city, port of entry, and the seat of justice of Erie co., Pennsylvania, situated on Lake Erie, nearly midway between Buffalo and Cleveland, 117 m. N. of Pittsburgh; pop. in 1840, 3,412; in 1850, 5,858; in 1860, 9,419; in 1870, 19,646, of whom 6,928 were foreigners. It stands upon an elevated bluff commanding a fine view of the lake. The streets are broad, and laid out at right angles with each other. State street is the principal business thoroughfare. The city contains several parks. Among the public buildings are the post office, the custom house, and the opera house, recently constructed. The union depot, of brick, in the Romanesque style, is 480 ft. long, 88 ft. wide, and two stories high, and is surmounted by a cupola 40 ft. high. The Erie cemetery, occupying a plot of 75 acres on Chestnut street, near the city limits, is beautifully laid out with drives and walks, and is adorned with trees, flowers, and shrubbery. The Erie Extension canal (abandoned) connected the city with the Ohio river, and the Lake Shore and Michigan Southern, the Philadelphia and Erie, and the Erie and Pittsburgh railroads afford communication with Buffalo, Philadelphia, Pittsburgh, and the west. The harbor, which has been artificially improved, is  $3\frac{1}{2}$  m. long, over 1 m. wide, and from 9 to 25 ft. deep, and is protected by Presque Isle, formerly a peninsula, lying in front of the city. At the entrance are two lighthouses. There are several large docks, some of which are furnished with railroad tracks, so that the transfer of merchandise takes place directly between the vessels and the cars. For the year ending June 30, 1872, there were entered in the coastwise trade 429 steamers of 370,231 tons, and 796 sailing vessels of 267,466 tons; cleared, 427 steamers of 363,105 tons, and 867 sailing vessels of 286,960 tons; entered from Canadian ports, 59 American vessels of 16,137 tons, and 52 Canadian vessels of 8,604 tons; cleared for Canadian ports, 16 American vessels of 2,809 tons, and 41 Canadian vessels of 6,739 tons; value of imports from Canada, \$131,500; exports to Canada, \$48,823. There were belonging to the port 88 vessels of 16,669 tons, of which 23 of 9,376 tons were steamers, 19 of 5,231 tons

sailing vessels, and the rest canal boats and barges; built during the year, 5 vessels of 3,760 tons. The principal articles of shipment are lumber, coal, iron ore, and petroleum. The leading manufactures are of iron, embracing stoves, steam engines, machinery, car wheels, and car work, besides which there are several manufactories of bricks, leather, organs, pumps, furniture, and other wood work, a brass foundry, six petroleum refineries, five beer breweries, two ale breweries, three malting establishments, &c. There are four national banks, with an aggregate capital of \$850,000, a safe deposit and trust company, three savings banks, and four insurance companies. Erie is divided into six wards, and is governed by a mayor, and a select council of two members and a common council of three members from each ward. It is lighted with gas, and is supplied from the lake with water, which is forced by powerful engines to the top of a tower 200 ft. high, whence it is distributed through the mains. In 1872 there were 49 public schools, viz., 1 high, 16 grammar, 30 primary, and 2 evening, having 53 teachers and an average attendance of 2,154 pupils. St. Benedict's female academy (Roman Catholic) had 17 teachers and 60 pupils. The young men's Christian association has a library of 4,710 volumes. There are one daily and six weekly (two German) newspapers, an academy, marine hospital, city hospital, jail, orphan asylum, and 29 churches.—The French had a fort on the site of Erie, known as Fort de la Presqu'isle, about 1749. The town was laid out in 1795. A portion of it was incorporated as a borough in 1805, and in 1851 a city charter was granted. The fleet of Com. Perry during the war of 1812-15 was built and equipped here.

**ERIE, Lake,** the most southern of the five great lakes of the northern United States and of Canada, and the lowest of the chain, except Lake Ontario, which lies below it to the north-east. It is bounded N. by the province of Ontario, Canada, S. E. and S. by New York, Pennsylvania, and Ohio, and W. by Michigan, and lies between lat. 41° 25' and 42° 55' N., and lon. 78° 55' and 83° 34' W. Both the lakes named lie nearly in the extension of the line of the river St. Lawrence, the outlet of all these bodies of fresh water. The mean length of Lake Erie is about 240 m.; mean breadth, 40 m.; circumference, 660 m.; elevation above the level of the sea, 565 ft.; area, 9,600 sq. m. Its surface is 333 ft. above that of Lake Ontario, this great descent being made in the Niagara river, which connects the two lakes. The form of the lake is elliptical, its maximum length exceeding the mean by only about 15 m., and the breadth varying from 30 to 60 m. Its western extremity receives from the north the waters of the upper lakes, discharged by the Detroit river. At this extremity are many islands clustered together, the largest one about 14 m. in circumference. They are well wooded, with a fertile soil de-

rived from the limestone rocks of which they are composed, and to some extent they are under cultivation. The peculiar features of Lake Erie are its shallowness and the clayey nature of its shores, the depth, except near its lower end, rarely exceeding 120 ft. The United States engineers found three divisions in the floor of the lake, of increasing depth toward the outlet. The upper portion, above Point Pelee island, has a level bottom with an average depth of 30 ft. The middle portion takes in the principal part of the lake, extending to Long Point. The bottom is here level also, and from 60 to 70 ft. below the surface. Below Long Point the depth varies from 60 to 240 ft. Its bottom is a light clayey sediment, which rapidly accumulates from the wearing away of the strata that compose its shores. Along the coast the loosely aggregated products of the disintegrated strata are frequently seen forming high cliffs, which extend back into elevated plateaus. The rivers cut deep channels through these, discharging the excavated matters into the lake. The underground watercourses penetrate through the base of the cliffs and undermine them, and the waves aid to break them down. Slides are of frequent occurrence. The water takes up the earthy materials, and is rendered turbid by them a long way out from the land. This may be seen on both sides of the lake; and about Cleveland in Ohio the wearing back of the coast line has been particularly remarked. For 40 m., extending E. to Fairport, the shores are of this character, the stratified clays and sand forming a terrace, the height of which at Cleveland is 103 ft. above the water. Owing to the shallowness of the lake, it is readily disturbed by the wind; and for this reason, and for its paucity of good harbors, it has the reputation of being the most dangerous to navigate of any of the great lakes. Long continued storms, with the wind setting from one extremity of the lake toward the other, produce disastrous effects upon the land to leeward by the piling up of the waters. From this cause the city of Buffalo at the foot of the lake has suffered serious damage in its lower portions. The return of the waters after the storm is in some instances so rapid, when driven along by a wind setting in the same direction, that powerful currents are produced. In October, 1833, a current thus caused burst a passage through the peninsula on the N. coast called Long Point, and excavated a channel more than 9 ft. deep and 900 ft. wide. The natural harbors around the lake are few, and these have required artificial improvement. They are generally at the mouths of the small rivers which flow into the lake, the channels of which are carried far out by piers, constructed on one or both sides. Erie in Pennsylvania has a large natural harbor, formerly known as that of Presque Isle, which has been improved. The best harbor between it and Buffalo is Dunkirk. The other principal harbors on the S. side are those of

Cleveland, Sandusky, and Toledo. On the N. shore there is a harbor called Port Maitland, at the entrance of Grand river near the E. end of the lake, and this river is navigable by small vessels for some distance. Other harbors on the same side are Ports Dover, Burwell, and Stanley. Lake Erie drains but a narrow margin of country around it, and receives no rivers of importance. The Maumee is the largest on the American side, entering the lake at its S. W. extremity, its course being nearly on the extended line of the river St. Lawrence and the two lakes Ontario and Erie. Sandusky river, further E. in Ohio, rises about 60 m. S. of the lake; but more to the east the rise of the surface to the north reaches nearly to the lake shore, determining the drainage in the opposite direction, which is that of the general slope of the strata. The lake was early navigated by sailing vessels built upon its shores, and as many as seven steamers were running upon it in 1830. It is usually closed by ice in the early part of December, and continues more or less frozen over till March or April. In the season of navigation an immense amount of transportation is done upon it, and its commerce is of great value. The communication with Lake Ontario is through the Welland canal, constructed across the Canadian peninsula. On the American side are six customs districts, viz.: Buffalo Creek and Dunkirk, N. Y.; Erie, Pa.; and Cuyahoga, Sandusky, and Miami, Ohio. The value of the imports from Canada for the year ending June 30, 1872, was \$3,429,722; exports to Canada, \$3,945,588; entered from Canadian ports, 1,284 American vessels of 579,352 tons, and 986 Canadian vessels of 157,889 tons; cleared for Canadian ports, 1,168 American vessels of 533,845 tons, and 1,010 Canadian vessels of 162,509 tons; entered in the coast-wise trade, 3,340 steamers of 2,132,391 tons, and 8,229 sailing vessels of 1,934,972 tons; cleared, 3,377 steamers of 2,147,819 tons, and 8,397 sailing vessels of 1,976,408 tons. There were registered, enrolled, and licensed in these districts 1,576 vessels of 257,377 tons, viz.: 241 steamers of 79,054 tons, 429 sailing vessels of 93,295 tons, 886 canal boats of 75,971 tons, and 20 barges of 4,057 tons; built during the year, 88 vessels of 18,445 tons, viz.: 29 steamers of 8,914 tons, 15 sailing vessels of 4,256 tons, 38 canal boats of 3,829 tons, and 6 barges of 1,446 tons. The fisheries of Lake Erie are of little importance compared with those of the upper lakes, where the same kinds of fish are more abundant and of better quality. The chief varieties taken are lake trout and whitefish; other varieties are sturgeon, sisquit, muskelonge, black bass, white bass, Oswego bass, and several species of pike.

**ERIE, Lake, Battle of**, an important naval engagement in the war of 1812 between the United States and Great Britain, fought near the W. extremity of the lake, Sept. 10, 1813. The naval supremacy on the lakes was a matter of much moment, and the American forces on

Lake Erie were intrusted to Lieut. Oliver Hazard Perry, who equipped a squadron of nine sail at Erie on Presque Isle bay, and, although blockaded by the British fleet under Capt. Barclay, succeeded in getting his squadron out of port Aug. 12, 1813. On the 28th Perry was made master commandant, and on Sept. 10 lay in Put-in-bay, near Sandusky, when he discovered the British squadron in the offing, and went out to meet it. It consisted of six vessels, viz.: the ships Detroit and Queen Charlotte, the schooner Lady Prevost, the brig Hunter, and the smaller vessels Chippeway and Little Belt, in all mounting 63 guns, with 502 officers and men. Perry had nine vessels, viz.: the brigs Lawrence, Niagara, and Caledonia, and the Scorpion, Ariel, Somers, Porcupine, Tigress, and Trippe, with 54 guns and 490 officers and men. The Americans had some advantage in able seamen, Barclay's vessels being chiefly manned by Canadian watermen and soldiers. Only the Lawrence and Niagara, however, of the American squadron, were regular vessels of war, the others having been built for trading. Their guns were of heavier calibre than those of the English, but of shorter range. This enabled the British to open the battle with advantage. They concentrated their greater number of long-range guns on the Lawrence, Perry's flag ship, and by half past two o'clock, out of her 101 officers and men, only 18 were not disabled, and all her guns were rendered ineffective. In this desperate condition Perry left the Lawrence in command of Lieut. Yarnall, and shifted his flag to the Niagara, which lay half a mile to windward, crossing in his boat under a heavy fire. Lieut. Elliott of the Niagara, leaving his own ship, took command of the Somers, and brought up the smaller vessels of the fleet, which had as yet been little in the action. All together now bore down upon the enemy, and passing through his line, opened a raking cross fire, which in seven minutes compelled the surrender of the British flag ship Detroit, and of the Queen Charlotte, Lady Prevost, and Hunter. The Chippeway and Little Belt endeavored to escape, but were overtaken by the Scorpion and Trippe and surrendered to them about an hour later. When Perry saw that victory was secure he wrote with a pencil on the back of an old letter, resting it on his navy cap, the despatch to Gen. Harrison: "We have met the enemy and they are ours—two ships, two brigs, one schooner, and one sloop." The combat had lasted about three hours, with a loss on either side of about 130 in killed and wounded, Barclay himself among the latter. This victory completely established the American supremacy on the lake, and enabled the naval force to cooperate with Gen. Harrison by transporting troops and stores, so that Detroit was evacuated by the British, and Michigan released from British occupation and Indian warfare. Congress bestowed gold medals upon Perry and Elliott, and other rewards upon the officers

and men generally. The remains of the officers killed were buried at Put-in Bay island, on the anniversary of the battle in 1858, when the corner stone of a monument was laid.

**ERIE CANAL.** See CANAL.

**ERIES** (properly *Eriké*), a tribe of Indians of the same family as the Hurons, Iroquois, and Susquehannas. They seem in early times to have dwelt near the Niagara river and Lake Erie, but were driven inland by enemies in the west. They took no part in the war between the Iroquois and Hurons, but after the overthrow of the latter were attacked by the former about 1653. Being brave and expert bowmen and able to raise 2,000 warriors, they took up arms, invaded the Seneca country, and gained several victories, so that the Iroquois cantons sought the aid of the French and agreed to receive missionaries. An Iroquois army of 1,800 men in 1656 invaded the Erie territory, and, though the Eries sought to make peace, attacked one of their palisaded forts, to which they had fled. After a desperate resistance the fort fell, most of the Eries were put to death, and the remnant of the tribe was incorporated with the Senecas. Their locality at this time cannot be positively identified; it abounded in wild cats, whence they were called Chats by the French; and it was near oil springs. One of their towns was called Kentaienton.

**ERIGENA, John Scotus**, a scholastic philosopher, born near the beginning of the 9th century, in one of the British isles, probably Ireland. It is probable that he died about 880, but whether in France or England is uncertain. The most learned doctor and extraordinary thinker of his time, his life is best explained by supposing him to have been educated in Ireland, where a colony of philosophers had preserved almost intact, during the tumults of barbaric invasion, the traditions of the Alexandrian school of philosophy, elsewhere completely lost. Several writers agree in declaring that he travelled to Athens and acquired a knowledge of the Greek and oriental languages. Some old analysts identified him with John, abbot of Etheling, assassinated in 895, from which confusion Erigena enjoyed in some localities the honor of sainthood. He went to the court of Charles the Bald of France before 847, was placed at the head of the school of the palace, and engaged in the religious discussions of his time concerning grace and the eucharist, and in philosophical speculations. The king imposed upon him the task of translating into Latin the Greek works of the pseudo Dionysius the Areopagite, and of composing a treatise against the doctrines of Godeschalvus or Fulgentius about predestination. He affirmed the eucharist to be a remembrance or commemoration of the sacrifice upon the cross; and in answering those who annihilated the freedom of the will, he elevated the moral nature of man to the exclusion of the efficacy of grace. His views were condemned by the councils of Valencia in 855 and Langres in 859, and Pope

Nicholas I. demanded his disgrace of Charles the Bald. From this point information concerning his career is entirely wanting. Many of his works are lost, including the treatises *De Corpore et Sanguine Domini*, *De Visione Dei*, excepting an unimportant fragment, and *De Egressu et Regressu Animæ ad Deum*. His most important work remains, *De Divisione Nature*, which was first published at Oxford in 1681, and was republished in 1838, with notes by Schlüter, at Münster in Germany. An abstract of it is given in Sharon Turner's "History of the Anglo-Saxons." It contains all his philosophy, in the form of a dialogue between master and pupil upon the universe, nature, and what is termed that grand universality of being which embraces at once God and man. The human intelligence, according to him, is inhabited by emanations from the divine intelligence; our ideas are pure theophanies, or manifestations of the Creator in his creature. He divides nature into four categories: 1, God, who possesses and diffuses life; 2, the first causes or eternal ideas by which he accomplishes his work; 3, the sensible world of the creation, of which man is the summit; 4, God as he shall be at last when the perfected world, its destiny being accomplished, shall return to him. Several of his theological works were refuted by contemporaries; but the pantheistic consequences of his philosophical system were not formally condemned until the council of Paris in the 13th century. After the barbarous ages which followed the northern invasions, Erigena rose suddenly to the heights of metaphysics, undertook to reduce the Christian faith to a scientific system, and founded the philosophy of the middle ages. He was intimate with the ideas of Plotinus, Proclus, and the Greek fathers, and has been ranked as at once the last of the Neo-Platonists and the first of the scholastics.

**ERIVAN. I.** A Transcaucasian government of Russia, bounded by Georgia, Persia, and Turkish Armenia; area, 10,577 sq. m.; pop. in 1867, 435,658, of whom about 120,000 are nomadic and gypsy tribes, who are all Mohammedans, while the rest are Armenians. The principal river is the Aras or Araxes. The principal mountain is Mt. Ararat in the south. The country is rich in salt, gold, silver, and other minerals. **II.** A fortified city, capital of the government, on the Zenghi, an affluent of the Aras, 35 m. N. by E. of Mt. Ararat, and 116 m. S. by W. of Tiflis; pop. in 1867, 14,842. It is the seat of the Armenian catholics, the head of the entire Armenian church, who resides in the monastery of Etchmiadzin in the vicinity. It has a beautiful mosque, a large bazaar, a cannon foundry, and manufactories of morocco leather and of cotton fabrics. It is strongly fortified, is a station for caravans from Tiflis and Erzerum, and has considerable trade with Turkey, Persia, and Russia. It is thought to have been founded by an Armenian king in the 1st century of our era, and formerly occupied a site nearly a mile dis-

tant from its present one, to which it was transferred in 1635. In the vicinity, on a lofty rock, is an immense oval citadel, and the remnants of ruined cities are found in the surrounding plain. In the 16th century it became the residence of the Persian kings of the Sufi dynasty. Several times besieged and captured

of the Theiss, 66 m. N. E. of Pesth; pop. in 1870, 19,150, chiefly Roman Catholics and Magyars. It has weekly fairs, linen and cloth manufactories, and an important trade in wine, Erlau wine being the best red wine of Hungary. There are two warm springs here, much resorted to for diseases of the skin. The town



Erivan.

has four suburbs and many stately public buildings. The cathedral, the archiepiscopal palace, several churches, and the hospital founded by Komáromy, are the most notable edifices; the lyceum (formerly the university), a gymnasium, the episcopal seminary, a normal school, and a school of design are the principal learned institutions. Erlau, important as a bishopric from the time of St. Stephen, became the seat of an archbishop in 1804. In former times, though it possessed strong fortifications, it suffered much from Tartar and

by the Turks, it returned under Persian domination about the middle of the 18th century. The Russians were repulsed from it in 1808, but took it in 1827, and their general Paskevitch received the surname of Erivanski. It was confirmed to the Russians by treaty in 1828.

**ERLANGEN**, a town of Bavaria, in the circle of Middle Franconia, on the river Regnitz, the railway from Bamberg to Nuremberg, and the Ludwig's canal, 11 m. N. N. W. of Nuremberg; pop. in 1871, 12,511. It has a university, opened in 1743, which is the only Protestant institution of the kind in Bavaria. It was attended in 1873-'4 by 445 students, and has faculties of theology, medicine, &c., a museum of natural history, a botanic garden, and a library of about 120,000 volumes. There are an insane asylum, a Protestant gymnasium, and other schools. Erlangen is renowned among German towns for its pleasant and cheerful appearance. It is divided into an old and a new town. The latter is well built, and owes its origin chiefly to French Huguenots, to whom it was assigned as a residence by Margrave Christian Ernest in 1686, after the revocation of the edict of Nantes. In remembrance of this prince, the new town is frequently called Christian Erlangen. The town has manufactories of hosiery and gloves, and many breweries. A monument, designed by Schwanthaler, in honor of Margrave Frederick of Baireuth, adorns the public square.

**ERLAU** (Hung. *Eger*), a town of Hungary, capital of the county of Heves, in a deep and charming valley, on the river Erlau, an affluent

Turkish invasions, especially in 1552, when it repulsed under Stephen Dobó the repeated assaults of an immense Turkish army, and in 1596, when it was given up to the Turks by the foreign part of the Austrian garrison. Among the remnants of the old fortress the tomb of Dobó is still shown to visitors. Erlau was conspicuous during the revolution of 1848-'9 for the patriotic spirit of its inhabitants, and as the place whence Dembinski and Görgey started for their chief campaigns against the Austrians under Windischgrätz.

**ERMAN. I. Paul**, a German physicist, born in Berlin, Feb. 29, 1764, died Oct. 11, 1851. He first taught at the French gymnasium and the military school, and was professor of physics in the university of Berlin from its establishment until his death. His contributions to science embrace a wide range of subjects, and more especially magnetism and electricity. Having been for some time secretary of the academy for the physical sciences, he became on its reorganization joint secretary with the astronomer Encke of both the physical and the mathematical class. The galvanic prize instituted by Napoleon I. was awarded to him by the French academy of sciences in 1806. **II. Georg Adolf**, a German physicist, son of the preceding, born in Berlin, May 12, 1806. Between 1828 and 1830 he performed at his own expense a journey round the world, chiefly with the object of making a series of magnetic observations. Hansteen, who had been sent by the Swedish government on a similar expedition to western Siberia, was his fellow trav-

eller as far as Irkutsk. Here they parted company, Erman proceeding to Kamtchatka, whence he sailed to the Russian colonies in America, and returned to St. Petersburg and Berlin by way of California, Tahiti, Cape Horn, and Rio de Janeiro. A description of his journey is embodied in his *Reise um die Erde* (5 vols. 8vo, Berlin, 1833-'42). An English translation of the portion of his travels relating to Siberia, by W. D. Cooley, appeared in London in 1848 (2 vols. 8vo.). He has also published separate works on the course of the river Obi and on the animals and plants collected by him on his journey, and has contributed largely to Poggendorff's *Annalen* and other scientific periodicals. Since 1841, assisted by many Russian savants, he has edited the *Archiv für wissenschaftliche Kunde von Russland*, which is one of the best authorities on the subjects of which it treats. For several years he has held the professorship of physical science at the university of Berlin.

**ERMELAND** (Pol. *Warmia*), a region of East Prussia, between the rivers Passarge and Frisching; area, about 1,600 sq. m.; pop. about 200,000. It has formed a bishopric successively under the Teutonic knights, under the crown of Poland, and, since the first partition of that country in 1772, under Prussia.

**ERMINE**, a name given to several weasels, of the genus *putorius* (Cuv.), inhabiting the northern parts of both hemispheres, and which in winter exchange their brown color for a white livery more or less pure. The European ermine (*P. erminea*, Linn.) is about 10 in. long, with the tail half the length of the body; in summer it is reddish brown above, whitish below, with the tip of the tail black; in this livery it is called the stoat in Great Britain. In winter the upper parts become white, with a yellow tint beneath, the tip of the tail remaining black at all seasons; in this color the fur was formerly highly prized, especially for ornamenting garments pertaining to royalty and offices of dignity; for the purity of its whiteness it was taken as the emblem of incorruptibility and integrity. This animal is widely distributed in northern Europe and Asia, extending its range to the highest latitudes visited by man. Its habits are sanguinary, like those of all its genus, though from its smaller size it does less mischief in the farm yard than the polecat; it attacks and kills rats, mice, moles, and young poultry, sucking their blood; it often domesticates itself in houses, where its destruction of rats and mice in part compensates for its damage to the farmer in the hen house. There are at least five North American weasels entitled to the name of ermine; but it is very improbable that the *P. erminea* is found on this continent. The animal called ermine by Audubon and Bachman, and considered by them the same as the European, was first described as a distinct species by De Kay as *P. noveboracensis*. The color in summer is chestnut brown above, whitish below and on the inner surface of the limbs; edge of

upper lip white, and end of tail black; in winter, in northern latitudes, the hairs are snowy white from the roots, except on the end of the tail, which is black for about  $1\frac{1}{4}$  in.; south of Pennsylvania the color remains brown throughout the year. The head is depressed and acute;



*Putorius noveboracensis* in Summer Dress.

the ears are large and extend far round the meatus; the body is elongated, and the tail cylindrical, thickly clothed with fur about  $1\frac{1}{4}$  in. long at the end; the limbs are short and stout; there are five toes on each foot, the inner the shortest, all covered with fur, which hides the naked pads on the soles; on each side of the under surface of the tail are glands which secrete an offensive musky fluid. The fur is short, but very soft. The length to root of tail is  $10\frac{1}{2}$  to 11 in.; length of tail to end of hair  $6\frac{1}{2}$  to 7 in., the bones extending about  $5\frac{1}{2}$  in. It is a graceful, quick, and fearless animal, living under logs and heaps of stones, and in holes in rocks. It destroys rabbits, grouse, and domestic fowls much larger than itself; satiated with the blood of a single victim, it kills all within its reach from



*Putorius noveboracensis* in Winter Dress.

an instinctive propensity to kill; it has been known to destroy 40 fowls in a single night; from its vermiform body it is able to pursue hares into their burrows and the field mice into their galleries. Though occasionally destructive to poultry and eggs, it is much more a

benefactor to the agriculturist by killing the mice which devour his grain, potatoes, and grasses; it will soon rid a granary of the largest rats, and a field of the wheat-loving ground squirrels. It is not shy, and has been so far domesticated as to be employed like the ferret of Europe in hunting hares; it is easily taken in any kind of trap. It is not common anywhere; it prefers stony regions, and is solitary and nocturnal in its habits, though occasionally seen at all hours of the day. It is a poor swimmer and avoids water, and rarely ascends trees except when pursued. The young, from four to seven in number, are born between the last of March and the last of May, according to latitude. The coat is shed twice a year, in October and March, the autumn fur becoming white, and the spring brown. According to Prof. Baird, this species cannot certainly be traced N. of Massachusetts nor W. of Wisconsin; it has been taken at Fort Smith, Ark., and probably is found in most of the southern and southwestern states at a distance from the seacoast. The most striking differences between this and the European ermine are, that in the latter the caudal vertebrae are only a quarter the length of the head and body, the terminal hairs being nearly two thirds of their length, or from  $1\frac{1}{2}$  to  $2\frac{1}{2}$  in.; while in the former these vertebrae are nearly half the length of the body, the hairs being only about a quarter of their length, or not more than  $1\frac{1}{2}$  in.; in our species the ears and naked portion of the nose are larger; the coloration also differs in the much greater extension of the light colors on the lower parts and inside of the limbs in the European animal, and in the greater comparative extent of the black tip to the tail; there are 4 sacral and 21 caudal vertebrae in our ermine, and only 3 of the former and 19 of the latter in the European. The little ermine (*P. Richardsonii*, Bonap., or *P. agilis*, Aud. and Bach.), which replaces the preceding species north of Massachusetts, is from 8 to 9 in. long, exclusive of the tail, which is slightly more than 5 in.; the color in summer is dark chestnut brown above and whitish below, with the whole upper jaw brown, and the end of tail black one third to nearly one half of its length; in winter white with a black-tipped tail. It is smaller and darker, with more slender and delicate feet, than the preceding species; its geographical distribution is from  $65^{\circ}$  N. to Massachusetts on the E. and Vancouver island on the W. coast. The long-tailed ermine (*P. longicauda*, Rich.) approaches the ferrets in size, being about 11 in. long exclusive of the tail, which is 6 to 7 in.; the color in summer is light olivaceous brown above, and brownish yellow below, with the chin and edge of upper lip white; in winter white, with a black-tipped tail; the muzzle is broad, the hair short, coarse, and stiff, and the ears low and short; the feet are large, with well developed claws. It is found about the upper Missouri and Platte rivers. The least ermine (*P. Cicognanii*, Bonap., or *P. fuscus*,

Aud. and Bach.) has an average length of 8 in., with a tail of 3 or 4 in.; the colors are as in the other species in summer and winter; the edge of the upper lip is white; it is found from Labrador to Massachusetts, and as far west as Puget's sound. Kane's ermine (*P. Kanei*, Baird) is about  $8\frac{1}{2}$  in. long, with a tail of 4 in.; it seems a miniature of the European species, and is found in Siberia and the vicinity of Behring strait.

**ERNE, Lough**, a lake of Ireland, county Fermanagh, consisting of two sheets of water, called the upper and lower lakes, connected by a narrow winding channel. It is fed by the river Erne, which, rising in Lough Gowna, flows N. through county Cavan, and expands near Crum into the upper lake. This is about 12 m. long, from 2 to  $2\frac{1}{2}$  m. wide in its broadest part, and has a general depth of 20 ft., although in some places it is 75 ft. deep. There are 90 small islands in it, and the shores are generally low and marshy. The lower or northern northerly lake is 20 m. long, from 2 m. to 5 m. wide, and has a depth in some places of 225 ft. It contains 28,000 acres, and has 109 islets; Boa island, the largest, near the N. end, contains 1,300 acres. Both lakes abound with fish. The town of Enniskillen is partly situated on an island in the connecting channel, and there are a number of handsome residences and some well preserved ruins along its banks. The river leaves the N. end of the lower lake, and after a course of 8 m. empties into Donegal bay.

**ERNEST AUGUSTUS**, king of Hanover, fifth son of George III. of England, born June 5, 1771, died Nov. 18, 1851. He was for many years a member of the British house of lords as duke of Cumberland, and was a field marshal in the British army. Against the desire of his mother, he married in 1815 Frederica Caroline of Mecklenburg-Strelitz, widow of Prince Louis of Prussia and of the prince of Solms-Braunfels. The grant which he asked from parliament on occasion of his marriage not being accorded to him, he took up his residence in Germany, but returned to England in 1829 to vote against the Catholic emancipation bill, although it was proposed by his former political friend, the duke of Wellington. He again applied to parliament for money, for the education of his son George Frederick; but as it was only granted under condition that the young prince should be instructed in England and in the spirit of English institutions, he was compelled to remove his family from Germany. Grave imputations upon his private character, and his unbending opposition to all popular reforms, combined to make his residence in England as disagreeable to himself as it was hateful to the people. On the death of William IV. (June 20, 1837) the crown of Great Britain devolved on Queen Victoria, and the succession to the throne of Hanover being limited to the male line, the two countries were separated, and the duke

of Cumberland, eldest surviving brother of William, ascended the throne of Hanover. Here he became notorious for his tyrannical disposition. His first act was to abrogate the constitution of 1833, which had been sanctioned by William IV. In 1848 he yielded for a time to the exigencies of the moment, and granted a more liberal constitution. Shortly before his death he concluded a treaty with Prussia, by which Hanover joined the German Zollverein (Sept. 7, 1851). He was succeeded by his son, George V. (born May 27, 1819), who, though blind, reigned till Hanover was annexed to Prussia in 1866, when he took up his abode at Hietzing, near Vienna.

**ERNESTI. I. Johann August**, a German philologist, born in Tennstädt, Thuringia, Aug. 4, 1707, died in Leipsic, Sept. 11, 1781. He was made professor of ancient literature in the university of Leipsic in 1742, of eloquence in 1756, and of theology in 1758. His critical editions of Greek and Roman classics, Xenophon, Homer, Callimachus, Polybius, Suetonius, Tacitus, and Cicero are justly celebrated, especially the edition of Cicero's writings, and the glossary appended thereto, *Clavis Ciceroniana* (6th ed., Halle, 1831). His excellent Latin style obtained for him the surname of the German Cicero. As a theological writer he belonged to the school of rationalists. His most eminent theological work is the *Institutio Interpretis Novi Testamenti* (3d ed., 1775), of which an English translation, by C. H. Terrot, appeared in Edinburgh (2 vols. 12mo, 1833-'43). **II. August Wilhelm**, nephew of the preceding, born at Frohndorf, near Tennstädt, Nov. 26, 1733, died in Leipsic, July 29, 1801. In 1765 he was professor of philosophy in the university of Leipsic, succeeded his uncle as professor of eloquence in 1770, and edited the works of Livy (1769) and Ammianus Marcellinus (1773), besides many others.

**ERNST, Heinrich Wilhelm**, a German violinist and composer, born in Brünn in 1814, died in Nice, Oct. 8, 1865. He played in public at the age of 10, studied under Joseph Boehm of Vienna, and also under Mayseder and Seyfried. In 1829 he made his first professional tour, exciting much attention at Munich, Stuttgart, and other musical centres. In 1832 he went from Vienna to Paris, where he remained several years studying the violinists of the French school, especially De Bériot, whose favorite pupil he became. In 1840 he resumed his professional tours, in the course of which he visited Vienna, Berlin, and most of the other German cities, and later Poland, Russia, Sweden, Denmark, and England, where he remained several years. During the last eight years of his life he resided at Nice, an invalid suffering under a nervous malady that impaired his powers and rendered his life unhappy. Among the best known and most frequently played of his works are his *Elegie*, the concerto in F sharp major, his quartets for stringed instruments, and his violin studies. His fame,

however, rested principally upon his great merit as a virtuoso. He was called the most poetic of violinists, combining the grace and elegance of De Bériot with a deeper feeling and a larger and grander tone. In his best days he was almost without a rival in Europe.

**EROS**, in Greek mythology, the god of love. There are two distinct conceptions of Eros. In the earlier, which appears in Hesiod, and in Plato, Aristotle, and the Orphic hymn, he is one of the oldest of the gods, or even the first of the gods. Hesiod associates him with Chaos, Ge (Earth), and Tartarus. He is elsewhere described as a son of Cronos (Saturn) and Ge, or as a god who had no parentage and came into existence by himself. He was one of the fundamental causes in the formation of the world, inasmuch as he was the uniting power of love, which brought order and harmony among the conflicting elements of Chaos. The Romans gave this divinity no place in their religion, but when they speak of what they had heard from the Greeks translate Eros into Amor. The Eros of the later Greek poets is identical with the Latin Cupid, and is one of the youngest of the gods. He is generally called the son of Aphrodite (Venus), though sometimes of Polymnia, Penia, Artemis (Diana), or Iris; and his father is variously said to be Zeus (Jupiter), Porus, Hermes (Mercury), Ares (Mars), or Zephyrus. He was generally described as a handsome youth, but in the latest poets as a wanton boy full of tricks and cruel sports. In this stage he is the god of sensual love, bearing sway over the gods as well as over men, taming lions and tigers, and depriving Hercules of his arms and Zeus of his thunderbolts. His arms are arrows and torches, which no one can touch with impunity. He has wings. His eyes are sometimes covered, so that he acts blindly. He is the usual companion of his mother Venus. His statue and that of Mercury stood in the Greek gymnasia. The number of the loves is extended by later poets, who make them sons of Venus or of nymphs. Thespiæ in Bœotia was the most famous place for the worship of Eros; there it was very ancient, and the old representation of the god was a rude stone, to which exquisite sculptures were added in later times. A quinquennial festival, the Erotidia or Erotia, was celebrated there in honor of the god. The goose was sacred to him, also the hare, the cock, and the ram. He was a favorite subject with the ancient statuary, and Praxiteles represented him as a full-grown youth of perfect beauty. Respecting the connection between Eros and Psyche, see **PSYCHE**.

**EROSTRATUS**, or **Herostratus**, an Ephesian who lived in the middle of the 4th century B. C., and whom a deed of infamy has given a place in history. On the night in which Alexander the Great was born, in 356 B. C., he set fire to the great temple of Diana at Ephesus, which was utterly destroyed. When it was ascertained who had perpetrated the sacrilege, Eros-



tratus was arrested and put to the torture. Being asked why he had committed such an act, he replied, "To make my name immortal." The Ephesians thereupon passed a decree consigning his name to oblivion; but this ordinance proved vain, for Theopompus mentions the name in his history.

**ERPENIUS**, or **Van Erpen**, **Thomas**, a Dutch orientalist, born in Gorkum, Sept. 7, 1584, died in Leyden, Nov. 18, 1624. He was educated at the university of Leyden, travelled in England, France, Germany, and Italy, and perfected himself at Paris and Venice in Arabic, Turkish, Persian, and Ethiopic. In 1612 he returned to Holland, was appointed oriental professor at the university of Leyden, and established a press for the printing of Arabic works, with Latin translations by himself. He was subsequently appointed oriental interpreter to the Dutch government. He wrote many important works, including an Arabic grammar which remained the standard text book for more than a century.

**ERSCH**, **Johann Samuel**, a German cyclopædist, born at Glogau, in Prussian Silesia, June 23, 1766, died in Halle, Jan. 16, 1828. He was educated in the universities of Halle and Jena, and was afterward connected in Halle with Meusel's periodical, *Das gelehrte Deutschland*, and in Jena with a political journal. He published a voluminous collection of the documents found in German political, geographical, and scientific periodicals (3 vols., 1790-'92), which created a great sensation among German bibliographers. His efforts were so much encouraged by prominent savants, that he was induced to undertake a digest of literature in connection with a general literary gazette. Eight volumes (Jena and Weimar, 1793-1809) were required to epitomize the literary productions of 15 years (1785-1800). Not only books, but also newspaper and magazine articles, were recorded, and even the criticisms to which the respective literary productions had been subjected were referred to with the utmost precision. While this was in progress, he projected a universal cyclopædia of modern literature, which he carried out so far as to publish five volumes on French literature, *Das gelehrte Frankreich*, and an edition of the same in French under the title of *La France littéraire* (1797-1806). He was also engaged during the same period in various editorial labors. In 1803 he accepted the chair of geography and statistics at the university of Halle. He crowned the labors of his life by establishing in conjunction with Gruber the *Allgemeine Encyclopädie der Wissenschaften und Künste*, of which 17 volumes (the first appearing in Leipzig in 1818) were edited by Ersch and Gruber. This is the most learned and elaborate German cyclopædia, and is still unfinished. (See CYCLOPÆDIA.) A third edition of his *Handbuch der deutschen Literatur seit der Mitte des 18ten Jahrhunderts bis auf die neueste Zeit* (2 vols., Amsterdam and Leipsic, 1812-'14) was pre-

pared by Geissler, who added to it a cyclopædia of philology in 1845 and of philosophical literature (Leipsic, 1850).

**ERSE**. See CELTS, LANGUAGES AND LITERATURE OF THE.

**ERSKINE**, **Ebenezer**, a Scottish theologian, founder of the Secession church of Scotland, born June 22, 1680, died in Stirling, June 22, 1754. The son of a Presbyterian clergyman, he was educated at the university of Edinburgh, licensed to preach in 1702, became pastor the next year in Portmoak, and held that post 28 years. Here and at Stirling, where he lived from 1731 until his death, he was a great favorite with his parishioners, as well as with the church throughout Scotland. The dissensions in the church of Scotland began in 1720, when the book entitled "The Marrow of Modern Divinity" was thought to reveal latitudinarian tendencies dangerous to the prevalent doctrines. Refusing to take the abjuration oath, and opposing the reimposition of lay patronage, as contrary to the act of union and to the liberties of the Scottish church, and at the same time being one of the most influential defenders of what were termed the "Marrow" doctrines, Mr. Erskine was proclaimed in many polemical pamphlets an innovator in religion and a troubler in Israel, was censured by the synod, and on Nov. 16, 1733, was solemnly rebuked and admonished at the bar of the general assembly. Against this decision he with three other clergymen entered a protest; and as they continued the conduct for which they had been censured, they were suspended from their functions. This sentence was removed July 2, 1734; but the deposed brethren had meantime formed themselves into a separate consistory and received numerous accessions. In 1740 Erskine and his brethren were again deposed and ejected from their pulpits; but he assembled his people on Sundays in the fields, till a new meeting house was provided, in which he continued to preach to large congregations till his death. There have been many editions of his "Select Works" (3 vols., 8vo) and of selections from them; also of his "Life and Diary," by D. Fraser.

**ERSKINE**, **Thomas**, baron, a British jurist and statesman, the third son of Henry David, fifth earl of Buchan, born in Edinburgh, Jan. 21, 1750, died at Almondell, near Edinburgh, Nov. 17, 1823. After studying in the high school of Edinburgh and in the university of St. Andrews, he entered the navy as a midshipman in 1764, and resigned in 1768 for a commission in the army. In 1770, soon after his marriage, he went with his regiment to Minorca, where he remained two years. After three years more of military service, during most of which time he was stationed in English country towns, he entered Lincoln's Inn, and was called to the bar in July, 1778. In November of the same year he defended Capt. Baille, lieutenant governor of Greenwich hospital, in a prosecution brought by Lord Sand-

wich, then at the head of the admiralty, for an alleged libel on other officers of that institution in respect of its management, and at once attained distinction as an advocate. The immediate effect of this effort was his reception of 30 retainers before he left the court. In 1779 he appeared at the bar of the house of commons as counsel for a bookseller against the monopoly of the two universities in printing almanacs, and the bill introduced by the prime minister, Lord North, to renew the monopoly, was defeated. In 1781 he secured the acquittal of Lord George Gordon, impeached for treason as the head of the "no popery" rioters. His practice and reputation increased so rapidly that he received in 1783, at the suggestion of Lord Mansfield, then presiding in the court of king's bench, the patent of precedence at the bar, and in the same year was returned to parliament as member for Portsmouth. He was a supporter of Fox, and advocated that minister's famous East India bill; but his parliamentary speeches were inferior to his pleas at the bar. His best efforts were those in defence of the freedom of the press and the privileges of juries, and against the doctrine of constructive treason. In his defence of the dean of St. Asaph, charged with libel, he indignantly argued against the judge who refused to receive the verdict of "Guilty of publishing only." One of his most important speeches was delivered in 1789 on the trial of Stockdale, who had published a pamphlet containing severe reflections upon the conduct of the managers of the impeachment of Warren Hastings, and was arraigned for a libel against the house of commons. Erskine's defence of Stockdale established his reputation as the most consummate advocate of the age, and the doctrine expounded in his plea and sanctioned by the verdict became the foundation of the liberty of the press in England. In 1792 he acted as counsel to Thomas Paine, prosecuted as author of the "Rights of Man," and was therefore deprived of the office of attorney general to the prince of Wales, which he had held since 1783. In 1794 he defended Hardy, Horne Tooke, Thelwall, and others, who were arrested and committed to the tower on charge of political conspiracy and high treason. The trial of Hardy began Oct. 29, and though the indictment stated nine overt acts of high treason, the trial turned almost solely on the question of treasonable intention. The proceedings continued to the eighth day, but the ability and eloquence of Erskine gained a verdict of acquittal, and forced the highest admiration even from his opponents. Tooke was arraigned Nov. 10, and pronounced not guilty on the 20th; his acquittal was followed by that of Thelwall; and the government abandoned the other indictments. Erskine looked with favor upon the attempt at social renovation in France, and opposed the interference of England on behalf of the Bourbons. His pamphlet entitled "A View of the Causes and Conse-

quences of the Present War with France" rapidly passed through 48 editions. Upon the death of Pitt in 1806, and the formation of Lord Grenville's coalition ministry, Erskine was appointed lord high chancellor, and created a peer under the title of Baron Erskine of Restormel castle, in Cornwall; but this ministry was dissolved within a year. He passed the remainder of his life in retirement, subject to pecuniary embarrassments from the loss of his large professional income and from unprofitable investments; while his domestic relations were disturbed by an ill-assorted marriage made after the death of his first wife in 1805. He took part for the last time in the house of lords in 1820, on occasion of the trial of Queen Caroline. Lord Erskine was one of the greatest of English advocates, and his eloquence may be compared to that of Pitt, Fox, Burke, and Sheridan. He presented to parliament the bill for the abolition of the slave trade, pleaded the cause of the Irish Catholics, supported propositions for the reform of the penal laws, and spoke and wrote in behalf of the struggling Greeks. His noblest efforts were in the cause of constitutional freedom, and during the momentous struggles of the period in which he lived no public man had greater personal influence. He left but few productions in writing. His parody of Gray's "Bard" was published in the "Monthly Magazine;" he wrote a preface to Fox's speeches, a political romance entitled "Armata, a Fragment" (published anonymously in 1817), and a few political treatises; but the chief foundation of his fame is his numerous speeches, which retain in print the brilliancy of thought, copiousness of imagery, elegance of diction, and much of the fervor which rendered them so successful when delivered. Collections have been published of his speeches at the bar in favor of the liberty of the press and against constructive treason (by James Ridgeway, 4 vols. 8vo, London, 1810-11); of his speeches at the bar on miscellaneous subjects (1812); of his speeches at the bar and in parliament, with a memoir by Lord Brougham (4 vols. 8vo, 1847); and of his select speeches, with a memoir by Edward Walford (2 vols. 8vo, 1870).

**ERYMANTHUS**, in ancient geography, a river and mountain of Arcadia, in Greece. The river, according to some the modern Dimitzana, rises on the frontiers of Arcadia and Elis, and flows into the Alpheus. The mountain, east of the river, formed the western point of the northern barrier of Arcadia, and was covered with forests. In this mountain Hercules killed the famous wild boar.

**ERYSIPELAS** (Gr. *έρπειν*, to draw, and *πέλας*, neighboring, from its tendency to draw in the neighboring parts; called also **St. ANTHONY'S FIRE**, or in Scotland **ROSE**), an inflammation of the skin characterized by redness, swelling, and burning pain, commonly spreading from a central point, and sometimes affecting the

subcutaneous cellular tissue. Idiopathic erysipelas almost invariably attacks the face; frequently it is preceded by loss of appetite, languor, headache, chilliness, and frequency of pulse; a deep red spot now makes its appearance, commonly on one side of the nose, swollen, firm, and shining, and is the seat of a burning, tingling pain. The disease gradually extends, often until the whole of the face and hairy scalp has been affected, but it is exceedingly rare for it to pass upon the trunk. Often, while it is still advancing in one direction, the part originally affected is restored to its normal condition. Commonly large irregular vesicles (*phlyctenæ*) filled with serum, precisely similar to those produced by a scald, make their appearance on the inflamed skin. The pulse is frequent, there is total loss of appetite, headache, prostration, restlessness, and sleeplessness, and commonly, particularly at night, more or less delirium. The complaint runs its course in about a week, and the general symptoms ordinarily abate somewhat before any decline is noticed in the local inflammation. In itself erysipelas of the face is ordinarily unattended with danger; but where it occurs in the course of other and exhausting diseases, it adds much to the gravity of the prognosis. In fatal cases the delirium is apt gradually to lapse into coma. Erysipelas is subject to epidemic influences; in certain seasons it is exceedingly prevalent, while in others it is rarely seen. The attack is favored by overcrowding and deficient ventilation. Hospitals, particularly in spring, are infested with it. Certain unhealthy states of the system predispose strongly to the disease, and an unwholesome diet and the abuse of alcoholic stimulants are commonly cited among its causes. We have seen that simple erysipelas is rarely fatal; consequently recoveries are common under a great variety of treatment. Usually it requires nothing more than to move the bowels by a mild laxative, and afterward to support the system by the administration of nutriment, and if necessary the use of quinine and wine whey. Where there is great prostration, stimulants may be administered freely. Systematic writers make a separate variety of the erysipelas of newborn children; it presents no peculiarity, however, except its greater gravity, in common with other diseases, in such delicate organisms. When erysipelas of the abdomen occurs in newborn children, it commonly has its point of origin in the recently divided umbilical cord. In some cases erysipelas, arising generally from some injury or excoriation, shows a tendency to advance in one direction while it passes away in another (*erysipelas ambulans*); in this manner it may pass over almost every part of the surface.—In phlegmonous erysipelas the precursory symptoms are more constant and severe, the pain more violent, the prostration greater; the redness is most strongly marked along the trunks of the lymphatic vessels, and the lymphatic glands are swollen;

the swelling of the skin is more considerable, it soon assumes a pasty consistence, and pits strongly on pressure. As the disease advances, the pain subsides, the redness is diminished, and fluctuation becomes evident; if left to itself, the skin, gradually thinned and distended, sloughs over a larger or smaller space, and pus mingled with shreds of dead cellular tissue is discharged. The disease indeed seems usually to be in the cellular tissue rather than in the skin, and sometimes the cellular tissue throughout a limb appears to be affected. It is a disease of great severity, and when extensive often proves fatal under the best treatment. In its treatment, the same general principles apply as in simple erysipelas. The patient's strength should be supported by a nutritious diet, and tonics and stimulants must often be freely administered. Early in the disease the skin should be freely divided down into the cellular tissue, to relieve the constriction of the parts and afford an opening to the discharges.

**ERYTHEMA** (Gr. *ἐρυθμα*, to redden), an affection of the skin characterized by a slight redness without determinate form. It is generally due to the action of some special cause, as the heat of the sun, &c. Where it is produced by the friction of two contiguous surfaces, as frequently occurs in infants and in fleshy persons, it is often called *intertrigo*. *Erythema nodosum*, the severest form of the disease, is characterized by the eruption of numerous red spots from one third of an inch to an inch in their longest (vertical) diameter. These spots are slightly elevated; after a few days their color deepens, and passing through various shades of blue and yellow, the skin resumes its normal color. The affection is apt to be attended with fever, depression of strength, and derangement of the digestive organs. Simple erythema needs no treatment beyond the employment of soothing applications; in intertrigo, the use of an absorbent powder, as lycopodium, starch, &c., may be advisable. Erythema nodosum is best treated by diet, rest, and a mild laxative; in some cases tonics and iron are useful.

**ERYTHRÆAN SEA** (Gr. *ἐρυθρὸς, ἐρυθραῖος*, red, ruddy), in ancient geography, originally the name of the whole expanse of sea between Africa on the S. W., Arabia on the N. W., Gedrosia on the N., and India on the N. E., including the two great gulfs, the Arabian and the Persian. In this wider sense the term seems to have been used by Herodotus, who designates by it both the Indian ocean, of the shape of which he was ignorant, and the Persian gulf, distinguishing the Red sea, the *yam suf* or weedy sea of the Hebrews, which he calls the Arabian gulf. The term *ἡ νοτιή θάλασσα* (southern sea) appears in some passages of the same historian as identical with the Erythræan, in others as designating the more distant and less known region of the latter. Later and better informed geographers, distinguishing the separate parts of the sea,

applied to its main body the name of Indian ocean, and to its great gulfs the names of Persian and Arabian, while the term Erythraean sea (Lat. *Mare Rubrum*) was variously used by different writers until it became confined to the Arabian gulf. The sea is supposed by some to have derived its name from the Phœnicians (Gr. *φολις*, red), who according to Herodotus originally dwelt on its shores; and by others from the red or purple hues imparted by coral reefs to the waters of the strait which connects the Red sea proper with the Indian ocean.

**ERYX**, an ancient town of Sicily, occupying the side of a mountain of the same name (now Monte San Giuliano), on the N. W. coast of the island, near the promontory of Drepanum. Above it was a temple of Venus, on the summit of the mountain. It early became a dependency of Carthage, was for a short time under the sway of Syracuse, was captured by Pyrrhus in 278 B. C., reverted to the Carthaginians, and in the first Punic war was partially destroyed by Hamilcar, who converted it into a fortified camp, removing the inhabitants to Drepanum. A few years later it was taken by the Romans, but the city was surprised by Hamilcar Barca, and made his headquarters till the conclusion of the war, while the Romans continued to hold the temple as an impregnable fortress. The site of the ancient city is now occupied only by a convent, and that of the temple by a Saracenic castle, now a prison, surrounded by the town of San Giuliano.

**ERZERUM**. **I**. A province or vilayet of Asiatic Turkey, comprising the greater part of Turkish Armenia, and bounded N. by Trebizond, E. by the Russian dominions and Persia, S. by Kurdistan, and W. by Sivas; pop. estimated at from 400,000 to 600,000. It consists mainly of lofty table land, the elevation of which is estimated at 6,000 ft., traversed E. and W. by several ranges of mountains, between which lie rich and extensive valleys. Cultivation is here well attended to, and the soil produces a profusion of excellent fruits, rye, barley, and flax, and furnishes pasturage for large herds. The climate in winter and spring is severe, and in summer the heat is excessive. The rivers Euphrates, Aras, Kur, and Tehoruk have their sources here. The mountains are inhabited mainly by Kurds, who acknowledge but a nominal allegiance to the

sultan. **II**. The capital of the province, and the principal city of Turkish Armenia, situated on the Kara-su or W. branch of the Euphrates, in a beautiful plain about 6,000 ft. above the level of the sea, 30 m. long and 20 m. broad, 110 m. S. E. of Trebizond, its nearest seaport. The population in 1829 was estimated at 130,000; but the large emigration of Armenians that year reduced it to about 45,000. A triple wall of stone which nearly surrounds the old part of the town, and a large massive citadel, encompassed by a double wall, and having four stout gates covered with plates of iron, are its principal defences. The citadel, however, is commanded by a hill in the neighborhood. The streets are narrow and filthy; the houses are mostly of wood, mud, or bricks dried in the sun; and the whole city is infested with savage-looking dogs. The principal buildings are the Greek and Armenian churches, and the custom

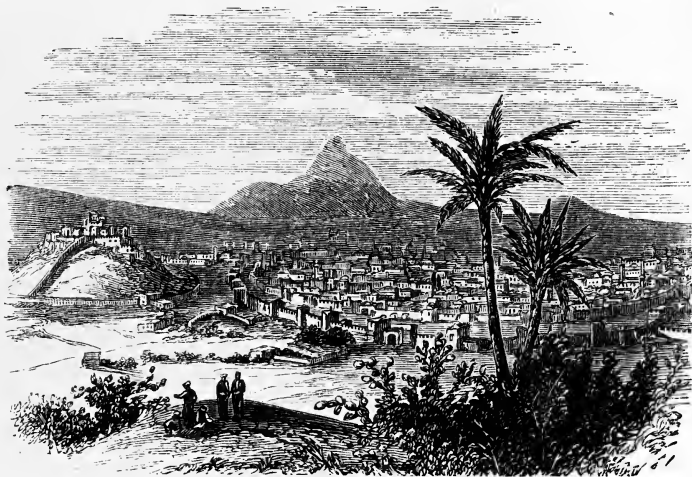

Erzerum.

house, besides which there are about 40 mosques and numerous caravansaries. Outside of the city are four suburbs. The caravans travelling from Teheran to Mecca usually halt here, and an active trade is carried on with all the adjacent countries. Shawls, silk, cotton, rice, indigo, tobacco, and madder are imported from the east, and broadcloth, chintz, cutlery, &c., from the west by the Black sea. The exports are furs, gall, and live stock.—Erzerum was built by a general of the emperor Theodosius II. about A. D. 415, and named Theodosiopolis. A little E. of it was the Armenian town of Arzen or Ardzen, the inhabitants of which, on the destruction of their place by the Seljuks in 1049, removed to Theodosiopolis. The name Erzerum is therefore supposed to be a corruption of *Ardzen Rum*, the Turks frequently applying the word Rum (or Rome) to any territory anciently recognized as a part of the Roman or Byzantine empire. Erzerum was twice destroyed by fire and pillage, and in

1829 was taken by the Russians under Paskevitch. Its position, which commands the road from Persia to Constantinople, renders it still an important military post, as it was in the time of its Byzantine masters, and also a point of great commercial interest. It is the seat of the Turkish governor general, of English and other foreign consuls, and of a United Armenian bishop; and it is the focus of the transit trade between Europe and Trebizond and central Asia and Persia. Several American missionaries reside here.

**ERZGEBIRGE** (Ger., Ore mountains), a range of mountains on the boundary between Bohemia and Saxony, and in its southern portion lying chiefly in Bohemia. It extends E. N. E. and W. S. W. about 100 m., and covers an average breadth of about 25 m. At its western extremity it connects with the range called the Fichtelgebirge, where the White Elster has its source. The river Elbe defines its E. extremity, flowing toward the north through the valley that separates the Erzgebirge from the Lusatian mountains. On the north the range slopes gently toward the plains of Germany, but on the south the descent is more precipitous, with deep and narrow valleys running down to the valley of the river Eger, which flows E. to the Elbe. The highest elevations are W. of the central part of the range. Here are the summits of the Keilberg, Fichtelberg, and Schwarzwald, all rising to a height of about 4,000 ft. above the sea. These are granitic peaks, but toward the Elbe, where the granitic rocks give place to sandstone, the elevation declines to a maximum of 1,800 ft. The range is traversed by six great roads, the most important of them connecting Prague with Dresden and Chemnitz. The valley of the Elbe admits the passage of the range by the railroad from Dresden to Vienna. The Erzgebirge have long been famous for their mineral productions, the most important of which are silver, tin, iron, cobalt, lead, and copper. Other mineral products are gold, found in small quantity, mercury, arsenic, bismuth, antimony, zinc, manganese, and sulphur. Coal is found in the lower country near Dresden and Zwickau, and porcelain clay at Aue, 12 m. S. E. of Zwickau, used in the royal manufactory at Meissen.

**ESARHADDON**, son and successor of Sennacherib, king of Assyria, reigned 680-667 B. C. He is the Sarchedon of Tobit, the Asaradinus of the Canon of Ptolemy, and the Asshur-akhiddin of the Assyrian inscriptions. (See ASSYRIA, vol. ii., p. 36.)

**ESCAMBIA**. I. A N. W. county of Florida, separated from Alabama on the W. by the Perdido river, bounded E. by the Escambia, and S. by the gulf of Mexico; area, 850 sq. m.; pop. in 1870, 7,817, of whom 2,880 were colored. It consists mostly of a level and not very productive country, covered with extensive pine forests. The chief productions in 1870 were 7,020 bushels of Indian corn, 13,970 of sweet potatoes, and 35,050 lbs. of rice. The value of

live stock was \$71,520. Capital, Pensacola. II. A S. W. county of Alabama, bordering on Florida, intersected by the Escambia and Conecuh rivers; area, about 600 sq. m.; pop. in 1870, 4,041, of whom 951 were colored. The Mobile and Great Northern and the Alabama and Florida railroads pass through it. The soil is sandy; pine abounds. The chief productions in 1870 were 30,390 bushels of Indian corn, 31,665 of sweet potatoes, and 605 bales of cotton. There were 8,785 cattle, 3,583 sheep, and 4,878 swine. Capital, Pollard.

**ESCHEAT** (law Fr. *eschet*, from *eschoir* or *échoir*, to fall out, or lapse), a failure in the regular descent of lands whereby the fee reverts to the original grantor or his heirs if they can be found, and if not, then to the sovereign, who, according to the feudal tenure, was the original source of title. Such a failure may occur for the want of heirs, or of such heirs as can inherit the particular estate. This could rarely happen as respects an absolute estate in fee, inasmuch as heirs may be sought to the remotest degree of collateral consanguinity on failure of lineal descendants; but it is not unfrequent where the estate is limited, as in the case of a marriage settlement by which the estate is to descend to the issue of the marriage, or of an estate tail by which a limitation is made to the heirs of a man's body or other specified heirs. In these and analogous instances, upon the failure of the heirs designated, although there may be others capable of inheriting generally, the title to the land reverts to the grantor if no other provision has been made in the deed creating the estate. The escheat in such a case is said to be *propter defectum sanguinis*. It may also occur by an obstruction of the descent *propter delictum tenentis*, that is, when there has been a conviction of felony; in which case, according to the old phraseology, there was a corruption of blood, so that the man thus convicted was deemed in law to have no heirs. A distinction was made between treason and other felonies. In the former case forfeiture to the crown intervened and prevented the escheat of the lands to the original proprietor; in the latter, the lands of the felon were intercepted by the crown for a year and a day, and then escheated to the lord of the fee. By statute 54 George III., c. 145, no attainder for felony except treason and murder is now permitted to defeat the right of the heir or other person who would by law be entitled to the estate, except during the life of the offender. By the common law bastards were not deemed to have any heirs except of their own bodies, for being without lawful parentage, they can have no collateral kindred; therefore upon the death of a person of illegitimate birth, leaving no issue and without will, his lands escheated. So in the case of a man dying intestate leaving only alien relatives; as they could not inherit, his lands would escheat. Formerly it was held that there could be no descent even to

natural-born subjects, between whom and the deceased there were lineal or collateral alien ancestors through whom they would be obliged to claim; but the statute 11 and 12 William III., c. 6, provides that an intermediate alien ancestor shall not impede the descent to one otherwise capable of inheriting.—The law of escheat in the United States varies from the English in several particulars. In New York, and generally in the other states, the ultimate property to lands is deemed to be in the people; and whenever in any private ownership there is a failure of descent by want of heirs, the property escheats to the people, or, as is more commonly said, to the state. The escheated lands are to be held, however, subject to all the trusts, encumbrances, &c., that they would have been had they descended; and authority is given to the courts of the state to direct a conveyance to the parties equitably entitled thereto. Conviction of any criminal offence except treason produces no forfeiture of lands or personal property; and where the punishment is imprisonment for life, the convict is deemed civilly dead, and his heirs take by immediate descent as they would upon his natural death. In the case of outlawry for treason there is a forfeiture of lands to the state during the life of the offender. The lands of a person dying intestate who is illegitimate do not necessarily escheat, but descend to his mother if living, or if she is dead, to the relatives on the part of the mother. As estates tail do not exist in the United States, many of the questions which arise in England upon the failure of particular heirs do not occur here. Properly speaking, an escheat to any private individual is unknown to our law. Not only feudal incidents, but the theory upon which they were founded, have been abrogated. In respect to aliens, a statutory provision similar to what has been enacted in England, as above mentioned, removes all disability of inheriting by reason of an intervening alien ancestor. Where property is purchased by an alien, or has been otherwise acquired, as by claim of inheritance, there being no other heirs, although by operation of law it escheats to the state, yet is his title good until divested by some proceeding on the part of the state to enforce the escheat; that is to say, it is valid against all other claimants, and even against the state itself until judgment has been rendered by some court declaring the escheat. In many of the states alienage of heirs is no longer a ground of escheat, aliens being allowed by statute to take by purchase or inheritance without restriction or impediment.

**ESCHENBACH, Wolfram von**, a German minnesinger, belonging to the circle of poets which near the end of the 12th and the beginning of the 13th century frequented the court of the landgrave Herman I. of Thuringia. He was of noble birth, fought under the banner of different lords in the civil wars of the time, and made his longest abode at the court of

Eisenach, in the mountain castle of Wartburg, where the landgrave Herman collected the most illustrious minnesingers. There he became associated with Heinrich von Veldeck, Walther von der Vogelweide, and other bards, and, according to tradition, engaged about 1207 in the poetical contest known as "the war of the Wartburg," and concluded by the magician Klingsor, the legends of which were collected in a famous poem about a century later. Eschenbach afterward sang at other courts, and died about 1225. Some of his poems are original, and others are imitations of troubadour songs and trouvère romances. Friedrich von Schlegel has called Eschenbach the greatest poet that Germany has produced. The first critical edition of his works was by Lachmann (Berlin, 1833; 2d ed., 1854). They have been turned into modern German by San Marte (Magdeburg, 1836-'41; 2d ed., Leipsic, 1858), and his *Parcival* and *Titarel* by Simrock (Stuttgart, 1842; 2d ed., 1857).

**ESCHENMAYER, Karl Adolf August von**, a German philosopher, born at Neuenburg, in Würtemberg, July 4, 1768, died Nov. 17, 1852. From 1811 to 1836 he taught philosophy and medicine and afterward practical philosophy at the university of Tübingen. He produced a great variety of writings, chiefly on philosophy. His religious views are strongly tinged with mysticism, and several of his writings are directed against the theories of Hegel and against the "Life of Jesus" by Strauss. Among his principal works are *Religionsphilosophie* (3 vols. 8vo, Tübingen, 1818-'21), *Mysterien des innern Lebens, erläutert aus der Geschichte der Seherin von Prevorst* (Tübingen, 1830), and *Grundzüge einer christlichen Philosophie* (Basel, 1840).

**ESCHWEGE**, a town of Prussia, in the province of Hesse-Nassau, on the Werra, 27 m. S. E. of Cassel; pop. in 1871, 7,377. It consists of the old town on the left bank of the Werra, the new town on the right bank, and Brückenhäusen on a small island, connected with the other parts by stone bridges. It has an old castle, and manufactories of linen and woollen, leather, glue, soap, and oil.

**ESCHWEILER**, a town of Prussia, in the province of the Rhine, on the Inde, 8 m. N. E. of Aix-la-Chapelle; pop. in 1871, 15,550. It has manufactories of iron ware, machines, needles, wire, silk goods, ribbons, and leather. In the neighborhood are lead and coal mines.

**ESCOBAR Y MENDOZA, Antonio**, a Spanish casuist, born in Valladolid in 1589, died July 4, 1669. He was a Jesuit, distinguished for eloquence, and preached daily, and sometimes twice a day, during 50 years. He was also an indefatigable writer, and won a high reputation in his order for his works, which comprise over 40 volumes. His private life was marked by simplicity and purity; but the "probabilistic" principles on which is based the solution of many of his "cases of conscience" left him open to misconception and animadversion.

When Pascal, the great Jansenist writer, assailed the doctrines and morals of the Jesuits, Escobar's theology was selected by the satirist, as being the authorized teaching of the whole society. Although Pascal's *Lettres provinciales* were afterward condemned by the French episcopacy as heretical and defamatory, Escobar's name has continued to be held as typical of extreme laxity in morals; and the terms *escobarde*, *escobarderie*, *escobartin*, then introduced into the French language, still signify the reconciling of one's religious convictions with one's interest and passions. Among his works are: *San Ignacio de Loyola*, an heroic poem (1613); *Historia de la Virgen Madre de Dios*, an epic poem (1618); *Summula Casuum Conscientiæ* (1626); and *Liber Theologiæ Moralis, XXIV. Societatis Jesu Doctoribus reseratus, &c.* (1646).

**ESCURIAL** (Sp. *el Escorial*), a palace and mausoleum of the kings of Spain, in Escorial de Abajo, a town of 2,000 inhabitants, in a bar-

ren region, 2,970 ft. above the sea, on the S. E. slope of the Sierra Guadarama, in New Castile, 25 m. N. W. of Madrid, with which it is connected by railway. The correct title of this celebrated palace is "El real sitio de San Lorenzo el real del Escorial," so called from having been built in fulfilment of a vow made by Philip II. that he would build the most magnificent monastery in the world if St. Lawrence would give him victory over the French in the battle of St. Quentin, fought on that saint's day (Aug. 10, 1557). St. Lawrence suffered martyrdom by being broiled on a gridiron, and by a quaint conceit of the king or his architects, the ground plan is in the form of a gridiron, with handle and bars complete. Voltaire and other French writers have claimed for a Frenchman named Louis Foix the honor of having been the architect of the Escorial; but it is beyond doubt that Juan Bautista de Toledo commenced it from his own plans, and on his death in 1567 it was continued by his pupil,



The Escorial.

Juan de Herrera. The foundation was commenced on St. George's day, April 23, 1563. Twenty-one years' labor and a sum equal to \$15,000,000 were expended in completing the work. The body of the gridiron is represented by 17 ranges of buildings, crossing each other at right angles, forming a parallelogram enclosing 24 courts, with a square tower 200 ft. high flanking each of the four corners of the edifice, thus representing a gridiron reversed, the towers being the upturned feet. A wing 460 ft. long represents the handle of the implement, and contains the royal apartments. The average height of the walls is 60 ft. The total length of the edifice is 740 ft. N. and S., and 580 ft. E. and W. It contains the royal palace, royal chapel, monastery with 200 cells, 2 col-

leges, 3 chapter houses, 3 libraries, 5 great halls, 6 dormitories, 3 hospital halls, 27 other halls, 9 refectories, 5 infirmaries, a countless number of apartments for attendants, 80 staircases, 1,110 windows looking outward and 1,578 inward, or, including outhouses, 4,000 in all, besides 14 gates and 86 fountains. The whole edifice is built of white stone spotted with gray, resembling granite, and quarried on the site. The general aspect of the Escorial is that of a freshly erected pile, rising from the midst of plantations, and more imposing from its magnitude than from grandeur of architecture. The Doric is the prevailing order. The E. and W. terraces overlook the slopes; the N. and W. sides front the mountain, and are connected with the village by a subterranean

gallery tunnelled in 1770 as a means of communication during storms. The most striking feature of the edifice is the church, built in general imitation of St. Peter's at Rome, in the form of a Greek cross with a cupola and two towers. It contains 40 chapels with their altars, and is 364 ft. long, 230 broad, divided into seven aisles, paved with black marble and roofed by the dome rising 330 ft. from the floor. The grand altar, 90 ft. high and 50 ft. wide, is of jasper and gilded bronze. Eighteen pillars, each 18 ft. high, of red and green jasper, support an estrade on which the altar is placed. Porphyry and marbles of the richest description incrust the walls, and on either side are statue portraits of the kings. Directly under the high altar, so that the host may be raised above the dead, is a mausoleum built by Philip IV., from a design after the Roman pantheon. This burial place is 36 ft. in diameter, with walls of jasper and black marble. Here the remains of all the sovereigns of Spain since Charles V. repose in niches one above another. Another burial place in one of the chapels is called the pantheon of the *infantas*. Several fine paintings adorn the church, but it is much shorn of its embellishments since it was plundered by the French. Benvenuto Cellini's marble "Christ," presented to Philip by the grand duke of Tuscany, and brought from Barcelona on men's shoulders, is still shown here, and an immense collection of saintly relics amassed by the founder may also be seen. The interior of the church is a triumph of architectural effect, grand, massive, and solemn. On its steps are six colossal statues in granite, with marble heads and hands, and gilt crowns. These are called the kings of Judea. The edifice forms one side of a court, facing a finely sculptured portal, which opened twice for every Spanish monarch, once when he was carried through it after his birth, and once after his death, when three nobles and three priests bore him to the tomb. The royal apartments contain little worthy of notice, excepting two picture galleries, from which, however, most of the *chef's d'œuvre* have been removed to Madrid. The arched room of the great library is 194 ft. long, 32 wide, and 36 high. The ceilings were painted in fresco by Bartholomew Carducci. The library was said before the French invasion to have contained 30,000 printed and 4,300 MS. volumes, but we have no accurate estimate of its present contents. It is believed to contain between 4,000 and 5,000 MSS., of which 567 are Greek, 67 Hebrew, and 1,800 Arabic. The Arabic MSS. are not accessible to visitors. A portion of the library was destroyed by fire in 1671, and again in 1761; and the buildings were again seriously damaged from the same cause in October, 1872.

**ESDRAS, Books of,** two apocryphal books of the Old Testament, given as the third and fourth books of Ezra (the second being properly the book of Nehemiah) in several manuscripts of the Latin Vulgate, as well as in all

printed editions anterior to the decree of the council of Trent, which declared the two additional books uncanonical. In the English authorized version of the Apocrypha they are called 1st and 2d Esdras; in the Clementine and Sixtine versions of the Vulgate they appear at the end of the volume, being inserted, as expressly stated, in order to "preserve from being altogether lost books which had been sometimes cited by some of the holy fathers." Luther denounced the two books as worse than Æsop's fables; but the first was received into the Lutheran Bible, among the Apocrypha, while the second is counted among the pseudepigrapha. In all the manuscripts of the Septuagint, the first of these books, or the so-called third of Ezra, precedes the canonical books of the Jewish scribe, which in this version include that of Nehemiah. It is a recapitulation of the history related in the canonical book of the same name, interspersed with some interpolations taken from 2 Chronicles, Nehemiah, and other sources. It is written in an elegant style, resembling that of Symmachus, though it appears to be rather a version than an original work. The name and age of the author or translator are unknown. The 2d Esdras or 4th Ezra is of a different character from its apocryphal predecessor, and seems to owe its place among the uncanonical writings of the Old Testament only to the historical name which it bears. It contains a number of visions resembling those of the Apocalypse, related in a style acknowledged by prominent critics to rise occasionally to great sublimity of thought, energy of conception, and elegance of expression. This book also is supposed by some to be a translation from the Hebrew or Chaldee. But both the original and the Greek translation mentioned by Clement of Alexandria having been lost, the book was believed to exist only in the old Latin version, until more recent discoveries enriched Biblical literature with Arabic, Syriac, and Ethiopic translations. This book is ascribed to Ezra the scribe by Clement of Alexandria, and was regarded as prophetic by most of the fathers of the church, though it does not appear to have been known to Josephus. Jahn supposes the author to have been a Jew educated in Chaldea, and converted to Christianity, who flourished about the beginning of the 2d century. Dr. Laurence maintains that the author was a Jew who lived shortly before the Christian era; and he accordingly rejects as interpolations the first two chapters of the book, which furnish the chief argument for his acquaintance with the doctrines of Christianity. Dr. Lee conjectures the author to have been also the author of the book of Enoch. The Latin text is given in Hilgenfeld, *Messias Judæorum* (1869), and in the edition of the apocryphal books by Fritzsche (1871). The Ethiopic translation was published by Laurence in 1820.

**ESK,** the name of several rivers of Scotland. **I.** A river of Dumfriesshire, formed by



the junction of the Black and White Esk, runs S. E. to the English boundary, enters Cumberland, and falls into the Solway frith, after a course of about 30 m. **II.** A river of Edinburghshire, formed  $1\frac{1}{2}$  m. N. of Dalkeith by the junction of two head streams called the N. and S. Esk, flows N., and empties into the frith of Forth at Musselburgh. **III.** **North Esk**, a river of Forfarshire, rises among the Grampain hills, flows S. E., chiefly along the boundary between Forfarshire and Kincardineshire, and enters the North sea near Montrose; length about 25 m. It has valuable salmon fisheries. **IV.** **South Esk**, a river of Forfarshire, rises in the Grampians, flows S. E. and E., and enters the North sea near the mouth of the North Esk. It forms a large basin at Montrose, but is navigable only a short distance from the sea. It has salmon fisheries.

**ESKI-SAGRA**, a town of European Turkey, in the province of Roumelia, on the S. slope of the Balkan, 70 m. N. W. of Adrianople; pop. about 20,000. It is in a fertile region, and near it are several mineral springs. It contains several mosques; but its general aspect is even more wretched than that of most Turkish towns. The principal manufactures are carpets and leather. Large quantities of roses are raised in the vicinity.

**ESMERALDA**, a S. W. county of Nevada, bordering on California; area, 7,850 sq. m.; pop. in 1870, 1,553, of whom 56 were Chinese. It contains Walker lake, and is watered by East and West Walker rivers. The land along the rivers and lake is fertile. In this county is the great salt basin, 16 m. long and 3 m. wide, which is covered with pure salt. The White mountains are in the S. W. part. Gold and copper are found. Nine quartz mills are in operation, mostly for the production of silver. The chief productions in 1870 were 185,400 bushels of wheat, 103,920 of barley, and 4,405 tons of hay. There were 2,191 horses, and 6,078 cattle. Capital, Aurora.

**ESMERALDAS**. **I.** A river of Ecuador, the largest of those emptying into the Pacific. Its head waters are said to descend from the mountains Cotopaxi, Sincholagoa, Tiopullo, and Moreta, but it does not take the name Esmeraldas until the junction of the Guaillabamba and Blanco in lat.  $0^{\circ} 30' N.$ , from which point it holds a nearly N. course, almost wholly through dense forests, and falls into the ocean 10 m. below the town of Esmeraldas. Its mouth, on the W. side, is obstructed by sand banks, and it is not navigable for more than one third of its length, owing to cataracts and the inequality of its bed. The circumstance to which it owes its name really belongs to the Rio Quinindé, one of its tributaries, on the banks of which were once extensive mines of gold and emeralds. **II.** A province occupying the N. W. portion of Ecuador, and watered by the preceding river, bounded N. by Colombia, and W. by the Pacific ocean; area and population uncertain. On its coasts are the bay of

Ancon and the port of Pailon, besides that of its own name. The province is chiefly covered with forests, affording excellent timber for building, and various ornamental woods; which, with cacao, little inferior to that of Carácas, and tobacco of good quality, form the chief products. The inhabitants, almost exclusively mulattoes and zambos, live mainly on the banks of the rivers, and are occupied in the preparation of cacao and tobacco, and the manufacture of rum. There are few facilities for transport besides the rivers and a wretched road over the Cordillera to Quito. Education is at the lowest ebb; and although there are rich deposits of gold, iron, and emeralds, and a soil of unsurpassed fertility, the province is in a very primitive condition. It has five villages: Esmeraldas, Atacames, Rioverde, La Tola, and Concepcion. The new town of Esmeraldas, the present capital, is on the river Esmeraldas, 10 m. from its mouth, and 110 m. N. W. of Quito, with an excellent harbor. The old town of the same name, the former capital, is 6 m. further up the river. The climate is very hot, and both towns have not more than 1,500 inhabitants.

**ESNE**, or **Esneh** (anc. *Lato* or *Latopolis*), a town of Upper Egypt, on the left bank of the Nile, lat.  $25^{\circ} 20' N.$ , 28 m. S. S. W. of Thebes; pop. in 1870 estimated at 12,000. Until within a few years it was a dirty, poverty-stricken place, with mud houses, and in 1834 it was selected as a place of banishment for the ghawazi or dancing women of Cairo, and other females



Remains at Esne.

obnoxious to the laws. It is the emporium of the Abyssinian trade, contains manufactories of cotton goods, shawls, and pottery, and is a celebrated camel market. It is the seat of a Coptic bishop, and has three Coptic churches. The ancient city was large and important,

and its remains are mostly buried under large mounds covering the adjacent country. In the centre of the modern town, surrounded by filthy hovels, stands the portico of a great temple, in a fine state of preservation. It is supported by 24 massive pillars, each 5½ ft. in diameter and 40 ft. high. The portico is 112 ft. long, 53 ft. broad, and covered with sculptures and hieroglyphics. On its ceiling is a zodiac, like that of Denderah; over the dedication at the entrance are the names of Tiberius Claudius Cæsar, Germanicus, and Vespasian, and within occur those of Trajan, Hadrian, and Antoninus. The hieroglyphic inscriptions show that the oldest part of the temple was built by Ptolemy Epiphanes, about 200 B. C.; the portico was erected by the emperor Claudius, about A. D. 50; other portions are of still later date, the latest being erected by Vespasian, about 70. In 1843 Mehemet Ali had it cleared of the rubbish which filled the interior, and used it as a cotton warehouse.

**ESPARTERO, Joaquin Baldomero**, duke de la Vitoria, a Spanish soldier, born at Granatula, near Ciudad Real, Feb. 27, 1792. He is the son of a wheelwright, and was intended for the church, but in 1808 entered the army. He engaged in 1815 under Morillo in the war against the insurgents of South America, fought in Venezuela and Peru, and rose to the rank of brigadier general. After the surrender of the Spanish troops at Ayacucho in 1824, he returned to Spain with a considerable fortune. He favored the succession of Isabella II. to the throne, and the appointment of Queen Christina as regent during her minority. Upon the breaking out of the civil war after the death of Ferdinand VII. (1833), he was made commander-in-chief of the province of Biscay, and afterward lieutenant general. In the contest with the Carlists he displayed energy and ability, and was appointed general-in-chief of the army of the north, viceroy of Navarre, and captain general of the Basque provinces. In December, 1836, with the assistance of the British fleet, he drove the Carlists from Luchana, raised the siege of Bilbao, and was created count of Luchana. As a member of the constituent cortes he supported the new constitution of 1837. In that year he compelled the army of Don Carlos, which had advanced to the walls of Madrid (September), to retreat across the Ebro; in 1838 defeated the Carlist generals Negri and Guergué; and having gained new victories early in 1839, was created a grandee of the first class, with the title of duke de la Vitoria and of Morella. In August, 1839, he concluded with the Carlist general Maroto the convention of Vergara, which amounted to a submission on the part of the Carlists. Don Carlos left the country, and Cabrera, the only Carlist general who remained, was soon after defeated by Espartero. Queen Christina endeavored to strengthen her power by placing Espartero at the head of the ministry; and when in 1840 she was compelled

to resign the regency and retired to France, Espartero was appointed regent. During his administration insurrections broke out in different parts of Spain, especially at Pamplona and Barcelona. Espartero asserted his authority with ability and energy, refused several demands of the Christinos, and gave further offence by some commercial arrangements with England. A revolutionary junta assembled at Barcelona in 1843, and declared that Isabella had attained her majority, and that the regency was at an end. Espartero was deserted by all parties, and Narvaez, his personal enemy, in July entered Madrid in triumph at the head of an army. Espartero retired to England, where he resided till 1847, when he was restored to his honors, and resumed his position as senator. When Christina was again forced to leave Spain in 1854, Espartero was placed by Queen Isabella at the head of the cabinet, O'Donnell, the principal leader of the Christinos, being made minister of war. This coalition ministry was short-lived, and Espartero resigned in July, 1856. After the expulsion of Queen Isabella in 1868, he supported the provisional government. In 1870 several members of the cortes offered him the crown, but he declined it on the ground of his great age and his want of heirs.

**ESPARTO**, a species of grass or rush belonging to the genus *stipa*, a native of the south of Europe and the north of Africa. It abounds in southern Spain, where it is much used in the manufacture of cordage, nets, sacks, mats, baskets, &c., for which it is well adapted by the great strength of its fibre. The sandals called *alpargates*, worn by the Spanish peasantry, are made from it. Esparto cables are used in the Spanish navy, being considered superior to hemp, because from their lightness they float on the water, and are not so liable to be cut by a rough bottom.

**ESPINASSE, Mlle. de P.** See **LESPINASSE**.

**ESPINEL, Vicente**, a Spanish poet, born in Ronda, Andalusia, about 1545, died in Madrid about 1634. His father's name was Francisco Goma, but, according to a Spanish custom, he adopted the name of his maternal grandmother. He was educated at Salamanca, and afterward led an adventurous life in various parts of Europe. In his latter years he held an ecclesiastical office in his native town, though he passed much of his time in the capital. He was in pecuniary trouble through the whole of his career, and died in poverty, although he was the recipient of a pension from the archbishop of Toledo. Espinel was prominent among the Spanish poets of the 16th and 17th centuries, and some of his *canciones*, *redondillas*, pastorals, and elegies are spirited, picturesque, and harmonious in versification. He was also proficient in music, and is said to have added a fifth string to the guitar, which soon led to the invention of the sixth. But his chief work is his *Relaciones de la vida del escudero Marcos de Obregon*, which first ap-

peared at Barcelona in 1618, and has since passed through several editions in Spain. An English translation was made by Algernon Langton (London, 1816), and Tieck wrote an imitation in German (Breslau, 1827). Voltaire accused Le Sage of plagiarism, and denounced the "Gil Blas" as taken entirely from Espinel's "Marcos de Obregon."

**ESPIRITO SANTO**, a S. E. province of Brazil, on the Atlantic, bounded N. by the province of Bahia, S. by that of Rio de Janeiro, and W. by Minas Geraes; area, 14,049 sq. m.; pop. about 65,000. A very large proportion of the inhabitants are savages, dwelling in the interior, mostly descendants of the ancient Tupis and Aimorés, the latter being called Botocudos. The capital is Victoria. A branch of the Serra do Mar, here called Serra dos Aimorés, forms the natural western boundary, and throws off in regular succession a number of spurs, some of which gradually lower down to the coast, where they form abrupt rocky bluffs. The valleys between these hills are often very little broader than the rivers by which they are drained. There are some streams of considerable magnitude, the principal of which are the Mucury, which separates the province from that of Bahia, and the Doce. But few of the rivers are favorable to navigation, owing to their rapidity, irregular depth, and many cataracts. There are numerous lakes, mostly in connection with the rivers which empty directly into the ocean. There are few ports worthy of the name, Benevente being the best, and able to receive ships of considerable tonnage at any time of the tide. Victoria has an excellent harbor, but, on account of the barrenness of the surrounding country, will probably never be of much importance; and the mouth of the Doce is so dangerous as to render it useless for a port. Impervious forests cover the regions adjacent to the rivers; the plains toward the coast are pretty equally divided into meadow land and marsh; and altogether but little of the country has been brought under cultivation, notwithstanding the fertility of the soil, particularly N. of Victoria and S. of the Itapemirim. The chief products are maize, beans, coffee, mandioca, cotton and sugar in small quantities, and cacao, which is principally planted in the low grounds. Various attempts have been made to colonize the Doce, where is a great agricultural region; the chief cause of failure has been the ferocity of the aboriginal tribes. The rivers afford a plentiful supply of fish, nowhere surpassed for numbers of species and delicacy of flavor; and hosts of turtles are found along the coast. Rosewood is extensively exported, with some beans and other produce, and some coffee and sugar. The climate is generally hot, humid, and unhealthy.

**ESPY, James P.**, an American meteorologist, born in Washington co., Pa., May 9, 1785, died in Cincinnati, O., Jan. 24, 1860. He early manifested a fondness for meteorological sci-

ence, and after some years of investigation announced a theory of the origin and causes of storms, one of the features of which was the possibility of producing rain on a large scale by artificial means, which led to protracted discussions on the subject in the scientific journals. In 1841 his "Philosophy of Storms" was published simultaneously in Boston and London. He had previously communicated to the British association a paper on storms, and another on the "Four Daily Fluctuations of the Barometer." In 1843 he was assigned by the war department at Washington to a post in connection with the observatory, that he might prosecute meteorological investigations, and collated the reports from the different observers throughout the country. The information thus obtained was published in several quarto volumes by the department.

**ESQUIMAUX**, or Eskimos, the most northerly of the American native tribes, residing chiefly above lat. 60° N., and occupying Greenland, Labrador, the shores of the Arctic ocean, and the coast on the Pacific down to the peninsula of Alaska, and also a portion of the adjacent Asiatic coast. They are generally divided by writers into the Karalits or Greenlanders, the eastern or Labrador Esquimaux, the Iglulik or central, the Kotzebue sound or western, and the Tchuktchis in Asia. They call themselves Inuit (men). The name Esquimaux, applied to them by the Algonquins, means raw eaters. The early Norwegian settlers in Greenland called them Skroellings. They finally expelled the Norwegians from their country about the 14th century. Cartier heard of them, and his successors before the end of the 16th century traded with them on the Labrador coast; but the Basques by violence provoked them to war. They were in constant hostilities with the Algonquins, who at last drove them from the gulf of St. Lawrence, where Champlain places them on his map. They worshipped Torngak, an old man, god of the sea, and Supperukoak, goddess of earth. They are hardy, ingenious, active, and industrious, showing considerable skill. Crantz describes the Greenlanders as small but well proportioned, broad-shouldered, generally less than 5 ft. high, with high cheek bones, flat faces, small lustreless black eyes, round cheeks, small but not flat noses, small round mouths, long, straight, coal-black hair, large heads and limbs, and small soft hands and feet. They root out the beard, and are inclined to corpulence. Their body is of a dark gray color, but the face brown or blue. This brown color seems not altogether natural, because their children are born as white as others, but it is due in part to their habits; for they are constantly handling grease, and seldom wash themselves. Lesson describes them as superstitious to excess. Polygamy is practised, and women are regarded as creatures of an inferior order, to be disposed of by the men according to their pleasure. Their dwellings are almost invariably near

the seashore, and are either permanent or temporary according to the situation and the materials at the disposal of the workman. In Greenland, where their permanent dwelling is of stone cemented by turf, it is usually not more than 6 or 8 ft. high, and is covered by a flat roof of wood and turf. It has neither door nor chimney, and the floor is divided into compartments by skins attached to the posts that support the roof. Each family has a separate apartment, and each apartment a window of seal skin dried, which is white and transparent. Benches are used as seats during the day and as couches during the night, the bedding being composed of reindeer skins. In Gilbert sound the houses are of wood, and at Regent's bay, and generally in Labrador, the roof is arched, and the habitation sunk 3 ft. in the ground; but the most remarkable houses are those built of the bones of whales and walruses, described by Frobisher and Parry. They also construct dwellings of snow and ice. Their dress consists of furs, in the preparation of which they exercise a degree of ingenuity superior to that of the most skilful furrier. The winter coat is usually made of seal skin, while the summer coat consists of that of the reindeer; but every variety of fur is occasionally used. The overcoat is supplied with a large hood, often bordered with white fur of the deer, which when drawn over the head presents a lively contrast with the dark face of the wearer. Those worn by the women have a much larger hood than those of the men, which not only furnishes a covering for the head but a cradle for the infant. The boots of the women are remarkable, and are sometimes made so large in the leg as to resemble a leather sack, which gives a ludicrous aspect to the whole figure. These capacious pouches are used as pockets, as temporary beds for infants, and, when in the vicinage of white men, as receptacles for stolen goods. As they are much upon the water, they devote considerable attention to the construction of their boats. These are of two kinds, the *caiak* or men's boat, and the *oomiak* or women's boat. The *caiak*, first described by Baffin, is adapted but for one person; it is about 16 ft. long, 2 ft. broad in the middle, and 1 ft. deep, and shaped like a weaver's shuttle. The bottom is rounded and has no keel. The frame is kept stretched above by 22 little beams, and two strong battens run from stem to stern, which toward the middle are attached to a hoop of bone large enough to admit the body. The frame is entirely covered, with the exception of a circular hole in the centre, with fresh-dressed seal or walrus skin. When complete the boat weighs about 60 lbs., and is so constructed that it can be carried on the head without the aid of the hands. The *oomiak* is from 20 to 25 ft. long, 8 ft. broad, and capable of accommodating from 10 to 20 persons. It is composed of the same materials as the *caiak*, and is often fur-

nished with a lug-shaped sail, formed of the intestine of the walrus, sewed together with great skill in breadths of about 4 in., and weighing less than 4 lbs. The mast has a neat ivory sheave for the halyards to run on, and is placed well forward. Much taste is displayed upon the bow and stern of the *oomiak*, but the Esquimaux chiefly prides himself upon the beauty and speed of his *caiak*, in which he defies the storm, and does not hesitate to approach and give battle to the polar bear and other monsters. The Esquimaux sledge, which is drawn by dogs, is sometimes made of wood, but bone sleds are almost exclusively used at Shishyaroff inlet and Regent's bay. At Regent's inlet the sled is made of a number of salmon packed together in the form of a cylinder about 7 ft. long, encased in skins taken from canoes, and well corded with thongs.



An Esquimaux Hunter.

Two of these cylinders are pressed into the shape of runners, and having been left to freeze, are secured by cross bars made of the legs of the deer or musk ox. The bottom of the runner is then covered with a mixture of moss, earth, and water, upon which is deposited about half an inch of water, which congeals in the act of application. These sleds travel more lightly than those shod with iron; but as they cease to be of service when the temperature rises above the freezing point, they are then taken to pieces, and the fish being eaten, the skins are converted into bags and the bones given to the dogs. The Esquimaux hunt with bows and arrows, spears and slings. They are fond of ornaments, and carve with much skill. Capt. Logan found on the E. coast of America models of men, women, and children, of beasts, birds, and fishes, executed in a masterly style, and with no mean

knowledge of anatomy. The ivory or walrus tusks of which they form their models are cut by continued chopping with a knife, one end of the ivory resting on a soft stone, which serves as a block. To smooth and polish the work, a gritty stone is used as a file, and kept constantly wet with saliva. Richardson represents these people as scrupulously honest toward each other, but utterly regardless of the property rights of strangers. They subsist almost exclusively upon fish and animal food, which the rigor of the climate enables them to eat raw and in large quantities. Fat of animals and fish oil constitute their chief delicacies. Mr. John Simpson, physician of the ship Plover, says their principal settlements at Point Barrow, Cape Smyth, Point Hope, and Cape Prince of Wales are inhabited during the whole year; but Wainwright inlet, Icy cape, Port Clarence, and Norton sound, the coasts of Kotzebue sound, and other settlements and huts along the coasts, are only inhabited during the winter and deserted in summer. Their commercial places are Kinging on Cape Prince of Wales, Sesualing at the mouth of the Nunatak, Nigalek at that of the river Cobrille, and Nuwak on Point Barter. Four or five Asiatic boats are engaged in the trade, and land their freight at Sesualing, where a species of fair is held toward the end of July, which is distinguished not only for its active commercial but also for its pleasant social character.—Most ethnologists class the Esquimaux with the Mongolians; Prichard, Gallatin, Duponceau, and Archbishop Taché give to them the same origin as that of the hunting tribes of North American Indians. The Moravians began missions among the Esquimaux about the middle of the last century. The missions were permanently founded in 1770, Nain being established the next year and Okkak and Hopedale soon after. They have the Gospels in Labrador Esquimaux (London, 1810-'13), and in Greenland (London, 1822). The language has no *f*, *j*, *g*, *x*, or *z*, and *b*, *d*, *g*, *l*, and *n* never begin a word.

**ESQUIRE**, or **Squire** (Lat. *scutifer*, old Fr. *escuyer*, a shield-bearer), originally a warrior armed with shield and javelin. Under the later Roman emperors the name was applied to soldiers to whom especially was assigned the defence of the palace and person of the emperor. The name was adopted in France, from the earliest period of the monarchy, to designate those holding the first rank in the army. In the ages of chivalry the rank of esquire followed that of valet or page, and was the last degree of apprenticeship before attaining the honor of knighthood. (See CHIVALRY.) In England the title of esquire strictly belongs by right of birth to the sons of younger sons of dukes and marquises; to all the sons of earls, viscounts, and barons; to the eldest sons of baronets and of knights of all the orders. The title is also given to the officers of the king's court and household; to the officers of

the army and navy down to the captain inclusive; to doctors of law, barristers, physicians, justices of the peace while in commission, and the sheriffs of counties for life. The heads of many old families are also deemed esquires by prescription. But the title is now so generally bestowed that it has lost its strict technical value. It is ordinarily used as a mark of respect in the superscription of letters in England and in the United States.

**ESQUIROL**, **Jean Étienne Dominique**, a French physician and philanthropist, born in Toulouse, Jan. 4, 1772, died Dec. 12, 1840. He was studying at Paris when the revolution broke out, and led him to enter the medical service of the army. In 1794 he attended the military hospital in Narbonne, and on his return to Paris he became Pinel's assistant in the *Salpêtrière*, and took at the same time an able part in the editing of Pinel's medical journal (*Médecine clinique*). In 1799 he founded a lunatic asylum, which became the model of all similar institutions afterward founded in France. He was appointed physician to the *Salpêtrière* in 1811. In 1817 he opened a course of clinical lectures, in which he pointed out the reforms needed in the treatment of lunatics, and at the same time became one of a government commission on the subject. In 1823 he was appointed inspector general of the university for the faculties of medicine, and in 1825 physician-in-chief to the royal institution for the insane at Charenton. In 1830 he was deprived of his offices in consequence of his opposition to the July revolution. He contributed many important papers to the *Encyclopédie des gens du monde*, and to the great *Dictionnaire des sciences médicales*. In 1838 he published a more elaborate work, *Des maladies mentales, considérées sous les rapports médical, hygiénique, et médico-légal* (2 vols. 8vo).

**ESQUIROS**, **Henri Alphonse**, a French author and politician, born in Paris in 1814. He published some poetry in 1834, and subsequently wrote in the socialist interest, and in 1840 was imprisoned for eight months on account of his heterodox description of Christ in *L'évangile du peuple*. He was an ultra-radical member of the legislative assembly from 1849 till Dec. 2, 1851, when he was banished, and went to Holland, and afterward to England. Under the amnesty of 1869 he returned to France, and was elected to the legislative body. He was prefect of the department of Bouches-du-Rhône from September to November, 1870, and in February, 1871, was elected to the national assembly, of which he was still a member in 1873. Among his works, besides several novels, are: *Les vierges martyres, Les vierges folles, and Les vierges sages* (1841-'2); *Histoire des Montagnards* (2 vols., 1847); *Les fastes populaires* (4 vols., 1851-'3); *La Néerlande et la vie hollandaise* (2 vols., 1859; English translation, "The Dutch at Home," 1861); and *L'Angleterre et la vie anglaise* (5 vols., 1869-'70; English translation by L. Wraxall,

4 vols., 1861-'3).—His wife, ADELE, has written several works, and assisted her husband in *Histoire des amants célèbres de l'antiquité*.

**ESS, Heinrich Leander van**, a German Roman Catholic theologian, born at Warburg, Westphalia, Feb. 25, 1770, died in Affolterbach, Oct. 13, 1847. He entered the Benedictine order in 1793, and officiated as pastor in a village from 1799 to 1813, when he became pastor and professor of theology at the university of Marburg. Conjointly with his cousin and fellow Benedictine, Karl van Ess (1770-1824), he published a new German translation of the New Testament (Brunswick, 1807; 20th ed., Sulzbach, 1830), which is highly valued. They also published *Das Alte Testament* (Nuremberg, 1819), and *Die Heilige Schrift Alten und Neuen Testaments* (Sulzbach, 1840). Heinrich made himself widely known by his endeavors to promote the reading of the Bible among the Catholics of Germany, for which purpose he prepared *Auszüge aus den heiligen Vätern* (2d ed., Sulzbach, 1822); *Pragmatica Doctorum Catholicorum Tridentini circa Vulgatam*, a prize essay (Sulzbach, 1816; German translation, Tübingen, 1824); *Was war die Bibel der ersten Christen?* (1816); *Gedanken über Bibel und Bibellese* (1816); *Die Bibel nicht ein Buch für Priester* (1818); and *Rechtfertigung der gemischten Ehen*, a work in defence of marriages between Catholics and Protestants (1821). His views in regard to the general reading of the Bible by the people being disapproved by the German bishops and by the pope, he resigned his place at Marburg, and devoted himself to defending the position he had taken. After his death his library, comprising about 20,000 volumes, especially rich in early editions of the Bible, of the fathers, and of early theological writers, was purchased for the Union theological seminary in New York.

**ESSEG.** See ESZÉK.

**ESSEN**, a town of Prussia, in the province of the Rhine, near the Ruhr, 18 m. N. E. of Düsseldorf; pop. in 1846, 8,009; in 1861, 20,811; in 1871, 51,526. Few German towns have increased so rapidly during the last 20 years. Its growth is owing to its flourishing manufactures of woollen and linen goods, leather, vitriol, cast-iron and steel articles, gas apparatus, and steam engines. It has of late obtained a world-wide reputation by the famous cast-steel manufactory of Krupp, the largest in the world, employing about 10,000 persons. It is supplied with water from the Ruhr by an aqueduct 4 m. long. Until the beginning of the present century the abbess of the Benedictine nunnery (founded in 873) was the ruler of the town and the adjacent country, holding from about 1275 the rank of a princess of the empire. In 1803 the town was incorporated with Prussia; it was transferred to the grand duchy of Berg in 1808, but was regained by Prussia in 1813.

**ESSEN, Hans Henrik**, count, a Swedish general, born in Kallås, West Gothland, in 1755, died

July 28, 1824. He was educated in the universities of Sweden, and obtained the favor of Gustavus III. by his attainments and graceful and chivalric bearing. He accompanied him in his travels abroad, and was of great assistance in the campaign of Finland. He attended him to the masked ball where he was murdered by Ankarstroem, Essen having in vain warned him that an attempt was to be made on his life. In 1795, after having accompanied the regent duke of Södermanland and the young king Gustavus IV. to St. Petersburg, Essen was appointed governor of Stockholm. Subsequently he became governor general of Swedish Pomerania and of Rügen; and in 1807, as commander-in-chief of the Pomeranian army, he distinguished himself by his defence of Stralsund, and brought about an honorable truce with France. But the king, dissatisfied with Essen, assumed command of the army, and Essen retired from active service until the accession of the duke of Södermanland as Charles XIII., who created him a count and member of the council, and appointed him ambassador at Paris. In 1814 he marched at the head of the Swedish army against Norway; and when the two countries were united, he became governor of Norway, with the title of Norwegian field marshal and chancellor of the university of Christiania. In 1817 he was made governor general of Scania.

**ESSENCES.** See ESSENTIAL OILS.

**ESSENES**, a Jewish sect, not mentioned in the Jewish or Christian Scriptures, and concerning whom the only original sources of information are passages in the works of Josephus and Philo, both of whom lived about the time when the Essenes had reached their highest development. Philo, a disciple of the Alexandrian school of philosophy, attracted by their mystical and speculative turn, gives the fullest information concerning their doctrines. Josephus, who lived in Palestine where the community flourished, and according to his own statement was in early life a member of it, treats of them particularly in their outward relations. The Essenes first appear in history in the latter half of the 2d century B. C., as a society of piously disposed men, who in the solitudes on the western side of the Dead sea sought a retreat from the corruptions and conflicts of the world. They lived an austere life, held their property in common, wore a white robe, prayed and meditated continually, made frequent ablutions, for the most part renounced marriage, and often practised medicine. They sacrificed no animals, and instead of going themselves to worship in the temple of Jerusalem, they sent their offerings. Contemning logic, metaphysics, and even physical science, as useless, they gave their attention only to ethics, recognized no other authority than their own sacred books, and taught the equality of men and the entire supremacy of destiny. Their number at the beginning of the Christian era was about 4,000. After the destruction of

Jerusalem they disappeared from history. In the obscurity which covers their origin and the specialties of their conduct and ideas, they have been variously compared to the old Hebrew schools of prophets, the Greek Pythagoreans and Stoics, the Christian monks, and the modern Quakers. De Quincey has sought to identify them with the early Christians, who, surrounded by dangers, assumed the name and mode of life of the Essenes as a disguise, alike impenetrable to Jewish or Roman enemies, and to timid or treacherous brethren. Monographs on the Essenes have been written by Bellermann, who identifies them with the kindred Jewish sect of the Therapeutæ in Egypt (Berlin, 1821), Sauer (Breslau, 1829), and Leutbecher (Amsterdam, 1857).

**ESSENTIAL OILS** (called also volatile oils, and distilled oils), oily products derived from plants, generally by distilling portions of them with water. The aqueous vapor which passes over carries with it the vapor of these oils, though their boiling point is often higher than that of water. They condense together in the receiver of the still, the oil commonly floating upon the water, sometimes sinking beneath it. A portion appears to be taken up by the water, giving to it the peculiar odor and properties of the oil in a less degree. This is called medicated and perfumed water. The oils contain in a concentrated form the fragrance and essential properties of the plants, or of the portion of them employed, and when kept dissolved in alcohol constitute the essences. They may sometimes be obtained by expressing the parts containing them, as the rind of the orange and lemon; and sometimes they are so evanescent as to escape in the ordinary mode of securing them by distillation with water. The method then adopted, as in securing the oil in which lies the delicate fragrance of the tuberose, narcissus, jasmine, &c., is to arrange the flowers in layers with cotton imbued with some fixed and inodorous vegetable oil. This gradually absorbs the volatile oil of the flowers, and when the cotton is digested in alcohol, the volatile oil is taken up by this fluid, and an essence is obtained. In some cases it may be separated also by distilling the cotton with water or alcohol. The odor of the oil is often less agreeable than that of the plant, which is probably owing to its greater concentration, as by dilution it is made more pleasant. The oils are often colored some shade of red, brown, yellow, green, or blue, but this is not always fixed. Their taste is hot and pungent, but made pleasantly aromatic by dilution. Some are poisonous. They burn with a bright and often smoky flame. The feeling of them upon the hand is not greasy like that of the fixed oils, but rough, and a cork moistened with them grates harshly when turned in the phial. Their specific gravity varies from 0.847 to 1.17. They boil at various degrees, some at 320° F., and a few others require a higher temperature. Exposed to the air and light at ordinary tem-

peratures, they absorb oxygen, become darker and thicker, and are finally changed into resin, sometimes into acid compounds. Most of them consist, like the fixed oils, of a thin fluid and a solid product, which may be separated at a low temperature by compressing the substance between folds of paper. The camphor-like product called by Berzelius stearoptene is retained within the folds, while the oily fluid called elaioptene passes through. The ultimate analysis of the essential oils affords in most instances carbon, hydrogen, and oxygen. Some prove to be hydrocarbons, containing no oxygen; and in these the proportion of carbon is between 88 and 89 per cent., and of hydrogen between 11 and 12 per cent., which would be expressed by the formula  $C_8H_{14}$ . Nitrogen is found as a constituent of some of them, and sulphur is met with in the oils of mustard and of horse radish.—The agreeable odors retained by many of the oils cause them to be largely used in perfumery. Their medicinal properties also render many of them valuable agents. These properties depend upon the plants from which they are derived. Most of them are aromatics and stimulants. They are chiefly used in medicine to render other articles grateful to the taste or acceptable to the stomach, though some of them are employed for other purposes, as when the oil of cubeb is given to obtain the physiological actions of the berry from which it is derived. For a more detailed account of the remedial use of these oils the reader is referred to the articles upon the plants that yield them. Their dose is commonly only a few drops, which may be administered on a lump of sugar, or triturated with a dozen times their weight of sugar, and then mixed with water. Some are largely employed in the manufacture of paints and varnishes, some in printing calico, and some have been used for illuminating purposes.—Essential oils are frequently adulterated. The presence of fixed oils added to them for this purpose may be detected by the greasy stain left upon paper moistened with the liquid and exposed to heat sufficient to drive off the volatile oil. Alcohol is detected by various tests, as by adding water and agitating the mixture, which becomes milky if alcohol is present; and the bulk of the oil is reduced as the fluids separate on standing, by the alcohol leaving it and going with the water. A piece of potassium as large as the head of a pin will remain nearly 15 minutes in contact with a dozen drops of pure oil without change; but if it disappears in five minutes, the oil contains at least 4 per cent. of alcohol; if it disappears in one minute, it contains at least 25 per cent. Fused chloride of calcium is also used to abstract alcohol from the oils. When the high-priced oils are adulterated with the cheaper kinds, a thorough practical acquaintance with the physical properties of the oils can alone serve to detect the imposition. The odor of oil of turpentine when used for this purpose is concealed until the oil is dissolved in alcohol,

and water is added, when both the odor and flavor are easily recognized. The oils require to be kept in small bottles entirely filled, well stopped, and excluded from the light.—By recently devised chemical processes artificial essences imitating the flavor of various choice fruits are prepared from substances which would seem entirely unfitted for producing such results. Thus butyric acid, a product of butter or putrid cheese, being converted into an ether, cannot be distinguished from that prepared from the pineapple, and may be used equally well with the latter to produce the celebrated pineapple rum. The fetid fusil oil, separated from brandy and whiskey in rectifying these liquors, produces, when distilled with sulphuric acid and acetate of potash, an essence of pears; and if for the acetate of potash bichromate of potash be substituted, the product is an essence of apples. By similar methods a variety of other flavors are obtained; and though when concentrated they are acrid, they become very agreeable when used as flavoring in proportions of a drop to an ounce or two ounces. Some of the choicest perfumes are by similar chemical processes prepared from substances which seem strangely foreign to their nature.

**ESSEQUIBO.** I. The principal river of British Guiana, rises in the Acuray mountains near the S. limit of the country, lat.  $1^{\circ} 30' N.$ , lon.  $57^{\circ} 11' W.$ , traverses it in an almost northerly direction, and falls into the Atlantic by an estuary 30 m. wide at its mouth, about lat.  $7^{\circ} N.$ , lon.  $58^{\circ} 30' W.$  Its course is interrupted by numerous cataracts, the principal of which is that called King William's, about lat.  $3^{\circ} 14' N.$ , where navigation ceases. The upper part of its course is extremely tortuous; but below lat.  $5^{\circ}$  it bends northward, and holds that direction to its embouchure. The last of the more important rapids occurs about 60 m. from the mouth of the river, and mark the limits of the tidal movement. There are many considerable islands in the river and at its mouth. The entrance is rendered dangerous by a number of sand banks, like a succession of bars lying crosswise in the channel. The whole course of the stream is perhaps 450 m., mainly through a region of great natural beauty. The largest of the numerous tributaries of the Essequibo are the Rupununi, about 250 m. long; the Cuyuni, or Cuyuwini, a river of great magnitude flowing E. from the Venezuelan mountains and forming its junction near the S. part of the estuary through a mouth 1 m. wide; and the Putaro, in which is the stupendous cataract of Kaietur. (See GUIANA.) Numerous excellent fish are found in the Essequibo, the most remarkable of which is the formidable *peri* or *oma*, 2 ft. long, and armed with strong teeth; also large numbers of manatees or sea cows, of gigantic size, and in most respects distinct from those of the West Indies, and electric eels. II. A part of the territory of British Guiana, now united into one county with Demerara. (See GUIANA.)

**ESSEX**, the name of five counties in the United States. I. A N. E. county of Vermont, bounded N. by Canada, and E. by the Connecticut river, which separates it from New Hampshire; area, 790 sq. m.; pop. in 1870, 6,811. The surface is rough and mountainous, with numerous small lakes and ponds scattered over it. The soil is well watered, but, except in the valley of the Connecticut, not remarkable for fertility. It is traversed by the Grand Trunk railway from Portland to Montreal. The chief productions in 1870 were 13,613 bushels of Indian corn, 107,589 of oats, 229,941 of potatoes, 18,809 tons of hay, 233,285 lbs. of butter, 24,132 of wool, and 178,188 of maple sugar. There were 1,383 horses, 2,543 milch cows, 4,341 other cattle, and 5,716 sheep; 2 flour mills, 27 saw mills, and 6 starch factories. Capital, Guildhall. II. A N. E. county of Massachusetts, bounded N. by New Hampshire, and E. and S. E. by the Atlantic and Massachusetts bay, and traversed by the Ipswich and Merrimack rivers, the latter of which is navigable as far as Haverhill by vessels of 200 tons; area, about 500 sq. m.; pop. in 1870, 200,843. The surface is generally rough and the soil hard and rocky; but it is carefully cultivated, and in many places has been rendered very productive. The chief sources of wealth are commerce and the fisheries, for the prosecution of which the long line of seacoast broken by beautiful bays offers great advantages. The fishing interest is more extensive here than anywhere else in the United States. The interior towns are extensively engaged in the manufacture of leather, shoes, and cotton. The Boston and Maine and the Eastern railroads, with several branches, pass through the county. The chief productions in 1870 were 9,256 bushels of rye, 94,033 of Indian corn, 27,427 of oats, 20,653 of barley, 310,807 of potatoes, 50,299 tons of hay, and 335,885 lbs. of butter. There were 3,177 horses, 9,076 milch cows, 5,636 other cattle, 1,254 sheep, and 4,938 swine. There were 2,821 manufacturing establishments; capital employed, \$29,777,160; value of products, \$96,990,868. Those most important were 445 of boots and shoes, 111 of boot and shoe findings, 12 of cotton goods, 21 of woollen and 13 of worsted goods, 79 of carriages and wagons, 13 of hats and caps, 2 establishments for printing cotton and woollen goods, 6 for bleaching and dyeing, 24 for preparing morocco, 76 for currying leather, 59 tanneries, 14 flour mills, 34 machine shops, 5 paper mills, 43 yards for building and repairing ships, and 10 manufactories of cordage and twine. County towns, Salem, Lawrence, and Newburyport. III. A N. E. county of New York, bordering on Lake Champlain, and bounded N. partly by the river Au Sable; area, 1,656 sq. m.; pop. in 1870, 29,042. The country along the lake shore is tolerably level, but the N. W. part is occupied by the Adirondack mountains, which are covered with thick for-



ests. Tahawus or Mt. Marcy, 5,337 ft. high, is the principal summit, and the highest in the state. The county is drained by the head waters of Hudson river, and by Bouquet and Schron rivers, which afford valuable water power, and has numerous small but picturesque lakes. The soil is well watered, and there are immense beds of magnetic iron ore. The chief productions in 1870 were 49,850 bushels of wheat, 100,662 of Indian corn, 317,790 of oats, 49,184 of buckwheat, 406,122 of potatoes, 60,211 tons of hay, 993,974 lbs. of butter, 260,800 of wool, and 64,654 of maple sugar. There were 5,664 horses, 8,026 milch cows, 9,012 other cattle, 62,664 sheep, and 2,958 swine; 12 manufactories of carriages and wagons, 6 of charcoal, 3 of furniture, 20 of iron in various forms, 1 of nails and spikes, 1 of marble and stone work, 2 of sashes, doors, and blinds, 3 of starch, 2 of woollen goods, 7 tanneries, 17 saw mills, and 8 flour mills. Capital, Elizabethtown. **IV.** A N. E. county of New Jersey, bounded E. by Passaic river and Newark bay, and W. by Passaic river; area, 200 sq. m.; pop. in 1870, 143,839. The surface is generally level, but there are two elevated ridges in the W. part, known as First and Second mountains. Much of the soil is highly fertile. It is traversed by the New Jersey, the Newark, and Bloomfield, and the Morris and Essex railroads, and the Morris canal. The chief productions in 1870 were 7,579 bushels of wheat, 6,249 of rye, 66,192 of Indian corn, 22,107 of oats, 73,060 of potatoes, 11,328 tons of hay, and 125,232 lbs. of butter. There were 1,426 horses, 2,858 milch cows, 1,248 other cattle, and 1,164 swine. There is a large number of manufacturing establishments, chiefly in Newark, the capital. **V.** An E. county of Virginia, bounded N. E. by Rappahannock river; area, about 300 sq. m.; pop. in 1870, 9,927, of whom 6,650 were colored. It has an uneven surface in the W. part; the soil is generally sandy, of little natural fertility, but greatly improved by the use of marl, guano, and lime. The chief productions in 1870 were 47,577 bushels of wheat, 264,605 of Indian corn, and 14,757 of oats. There were 624 horses, 3,250 other cattle, and 3,055 swine. Capital, Tappahannock.

**ESSEX**, a S. W. county of Ontario, Canada, comprising a peninsula between Lake Erie and Lake St. Clair; area, 700 sq. m.; pop. in 1871, 32,697. It is separated from Michigan by the Detroit river, and is traversed by the Great Western railway. Capital, Sandwich.

**ESSEX**, a county on the E. coast of England, bounded S. by the river Thames, and bordering on Suffolk, Cambridgeshire, Hertfordshire, Middlesex, and Kent; greatest length from S. W. to N. E., 60 m.; greatest breadth, 45 m.; area, 1,657 sq. m.; pop. in 1871, 466,427. Except in the N. W., where there is a continual succession of hill and dale, the surface is nearly level, and in the S. and E. is partly occupied by large marshes. The soil is fertile, and the

farms are accounted among the best in the kingdom. Wheat is the staple production. The county is famous for its veal. Valuable fisheries and oyster beds furnish employment to the inhabitants of the coast and adjacent islands. Silk is manufactured, and straw plait is made for London use. The principal channels of communication are the Eastern Counties railway and its various connections, and the rivers Thames, Lea, Stort, Chelmer, Stour, and Colne. Chelmsford, the county town, Colchester, Harwich, and Maldon are the chief towns.

**ESSEX, Earls of.** I. See CROMWELL, THOMAS.

**II. Walter Devereux**, first earl of Essex of his name, born in Carmarthenshire, Wales, about 1540, died in Dublin, Sept. 22, 1576. He succeeded his grandfather early in the title of Viscount Hereford, and recommended himself to Queen Elizabeth by his bravery in suppressing the rebellion of the earls of Northumberland and Westmoreland in 1569. For this service he received the garter and the earldom of Essex. In 1573 he undertook an expedition, in company with other noblemen and gentlemen, for subduing and colonizing a portion of Ulster in Ireland; but in its prosecution he was subjected to many trials and disappointments. He was obliged to make peace with O'Neal, when, by continuing the war, he had the fairest prospects of driving him out of the country. He was also required to give up his command just as he had almost expelled the invading Scots from the western islands of his territory. Harassed with his difficulties, he retired to England, but was again induced to return, with the title of earl marshal of Ireland and the promise of support and assistance. As these promises were but poorly kept, he was overcome with grief, and the agitation of his mind threw him into a fatal dysentery. There was suspicion of poison, which was not diminished by the marriage, soon after, of his countess to the earl of Leicester. **III. Robert Devereux**, son of the preceding, second earl, born at Netherwood, Herefordshire, Nov. 10, 1567, executed Feb. 25, 1601. He succeeded to his title in his 10th year, and in 1577 was sent by his guardian Lord Burleigh to Trinity college, Cambridge, where he took the degree of master of arts. He appeared at court in his 17th year, and soon captivated Elizabeth. In 1585 he accompanied the earl of Leicester to Holland, and displayed his personal courage in the battle of Zutphen. In 1587 he was appointed master of the horse, and in the following year the queen created him captain general of the cavalry, and conferred on him the honor of the garter. He succeeded Leicester as prime favorite, and his attendance was constantly required at court. In 1589, when an expedition against Portugal was undertaken by Drake and Norris, Essex secretly followed the armament, and joined it on the coast of Portugal. Though he had departed without the permission of the queen, he was quickly reconciled with her after his return, and at once assumed a

superiority over Sir Walter Raleigh and Sir Charles Blount, the rival competitors for royal favor. He was challenged by Blount and wounded in the knee, and the queen is said to have expressed her gratification that some one had taken him in hand, as otherwise there would be no ruling him. In 1590 he married the daughter of Sir Francis Walsingham, the widow of Sir Philip Sidney, and in the following year had command of a fruitless expedition in Brittany against the Spaniards. When in 1596 alarm was excited by the hostile preparations in the Spanish harbors, he was joined with Lord Admiral Howard in command of the expedition against Cadiz. The intrigues of the Cecilis caused him to be coolly received on his return; but he quickly recovered favor. Two subsequent expeditions which he conducted against Spanish shipping met with little success. The queen received him with reproaches, and he retired to Wanstead; nor would he be pacified by her acknowledgment that the charges against him were unfounded, but after a long negotiation he accepted the office of hereditary earl marshal as indemnity for the promotion that had been given to his rivals. In 1598 he quarrelled with the queen about the appointment of deputy in Ireland, and when she boxed him on the ear for turning his back to her in presence of her ministers, he swore that he would not endure such an affront even from Henry VIII. himself, and withdrew from court. Only a formal reconciliation was ever effected. In 1599 the province of Ulster was in rebellion, and Essex accepted the lord-lieutenancy of Ireland. His campaign resulted only in a temporary armistice. He returned in haste, and retired from his first audience with a cheerful countenance, but was immediately ordered to consider himself a prisoner in his own house. After months of hesitation, he at length conceived the plan of forcibly banishing his enemies from her majesty's council. At the head of a force of about 300 men he made his way into London, but was disappointed in expecting the people to rise in his favor; he took refuge in Essex house, where he was besieged and forced to surrender. He was committed to the tower, tried for treason, condemned, and executed, the queen reluctantly signing the warrant. He was an accomplished scholar, and a patron of literature. He erected a monument to Spenser, gave an estate to Bacon, and was the friend of Wotton and other men of learning. **IV. Robert Devereux**, son of the preceding, third earl, born in London in 1592, died there, Sept. 14, 1646. He succeeded to his title in 1603, and in his 15th year was married to Lady Frances Howard, who was a year younger. He proceeded to the university and thence to the continent, while his wife remained at court, and numbered Prince Henry and Rochester (afterward earl of Somerset) among her admirers. In 1613 she obtained a divorce, and was soon after married to Rochester. Essex led a solitary life in his country

house, till in 1620 he raised a troop and served in the wars of the Netherlands. He was engaged in several campaigns abroad, and as vice admiral commanded a fruitless expedition sent by England against Spain. His second marriage also resulted unhappily and in a divorce. At the outbreak of the civil war he was appointed lord general by the parliament, laid siege to Portsmouth, and was proclaimed a traitor by Charles. He fought against the king at Edgehill (1642), captured Reading (1643), and advanced into Cornwall, but met with a succession of disasters which forced his army to capitulate. He escaped in a boat to Plymouth, and went to London, where a parliamentary deputation waited on him in honor of his faithful services. He again raised a corps, but ill health soon obliged him to quit his command. As early as 1644 he suspected Cromwell of a design to erect a new government. He therefore urged his impeachment before the house of lords, and Cromwell took revenge by proposing the "self-denying ordinance," by which members of both houses were excluded from all offices, whether civil or military. This measure having passed, Essex ceased to be a parliamentary general, but for his services £10,000 per annum was voted to him out of the sequestered estates of the loyalists.—The title expired with him, and was revived in 1661 in favor of Arthur, second Baron Capel, in whose family it still remains.

**ESSLING.** See ASPERN and ESSLING.

**ESSLINGEN**, a town of Württemberg, Germany, on the Neckar, 9 m. S. E. of Stuttgart, on the Ulm railway; pop. in 1871, 17,941. It is a place of great antiquity, and has old walls flanked with towers, and the old Berfried castle. The Frauenkirche is an admirable specimen of Gothic architecture of the 15th century, and is attended both by Protestants and Roman Catholics. The church of St. Dionysius was built in the Romanesque style in the 13th century, and enlarged in the 15th. There are several superior educational institutions, and a school for the deaf and dumb, and adjoining the town is the water-cure establishment of Kennenburg for the relief of the insane. Esslingen is important for its trade and industry. The fruit market is especially renowned; the culture of the vine is extensive, and the celebrated Esslingen champagne is the oldest sparkling wine in Germany. Railway locomotives are exported to many parts of the world. There are many manufactories of cloth, cotton, and woollen goods, optical and physical instruments, &c.—Esslingen became a free imperial city under the Hohenstaufen. The Swabian league was founded here in 1488. Its prosperity, increased after the reformation, but impaired by the thirty years' war and by intestine commotions, has been revived since 1801, when it became part of Württemberg.

**ESTAING, Charles Hector**, count d', a French naval officer, born at the château of Ruvel, Auvergne, in 1729, executed in Paris, April 28,

1794. He entered the military service, and in 1758 accompanied the count de Lally in his expedition to the East Indies, with the rank of brigadier general. He was taken prisoner at the siege of Madras, but was released on parole, and at once took command of two French men-of-war, and inflicted great damage upon the English in the East. On his return to France, in 1760, he was captured near Lorient, and thrown into prison at Portsmouth, the English asserting that he had resumed active service before he was authorized by the terms of his exchange, but was released, and in 1763 was appointed lieutenant general in the navy. In 1778 he was sent to the United States in command of twelve ships of the line and four frigates. He landed Gérard, the first ambassador from France to the United States, and then came to anchor off New York. An attack upon the city had been projected, but it was abandoned, the pilots thinking that the largest of the French vessels could not be taken over the bar. A joint attack upon Newport by land and sea was next proposed. D'Estaing sailed for Narragansett bay, entered Newport harbor, and compelled the British to burn or sink six frigates which lay there. A few days afterward the continentals, under Greene and Lafayette, landed on the island, and expected to be joined by 4,000 men from the French fleet. But D'Estaing had put to sea, and engaged Lord Howe, who had come to the relief of Newport. The fleets being separated by a storm, D'Estaing took his shattered vessels to Boston to refit, and the attack upon Newport was given up. In November he sailed for the West Indies, where he attempted without success to take the island of St. Lucia, but took St. Vincent and Grenada. He also forced the British admiral who had come to the relief of Grenada to retire. He then sailed for the coast of Georgia with 22 ships of the line. His troops cooperated with those of the Americans, Oct. 9, 1779, in an attack upon Savannah. Both the American column and the French were repulsed, D'Estaing being wounded and Pulaski killed in the assault. D'Estaing returned to France in 1780. He declared himself in favor of national reforms, and was elected in 1787 to the assembly of notables, appointed commandant of the national guard, and chosen admiral in 1792 by the legislative assembly. But he cherished a regard for the royal family, and wrote friendly letters to Marie Antoinette which came to the knowledge of the revolutionary authorities; and he was arrested and imprisoned. On the trial of Marie Antoinette in 1793 he testified in her favor. He was himself brought to trial in the following year, and condemned to death. He wrote a poem entitled *Le rêve*, a tragedy, and a book on the colonies.

**ESTATE** (Lat. *status*), in law, a term usually expressing an interest in lands, though in a general sense it is applied to both real and personal property, as we sometimes see in wills and the like. But when used with a discrimi-

native signification to designate the nature and limit of the interest, it properly relates to lands only. There are several classes of estates. I. An estate of inheritance, which is sometimes expressed by the term fee. Thus when we say a man has the fee of lands, it is meant that he has an inheritable estate; and in the United States, where there is no limitation to particular heirs, it is understood to be the entire proprietorship of the lands. But in England there are estates of inheritance in fee simple and fee tail, the former being an estate which descends to a man's general heirs, the latter being limited to certain specified heirs, as for instance to a man's issue male or female, or to the heirs of his body begotten of a certain wife. By such limitations, although the estate descends to the particular heirs, yet failing them it reverts to the grantor or supposed original proprietor, instead of descending to a man's general heirs; and so far there is an obstruction in the enjoyment of the estate, because a man is perpetuated in and represented by his heirs. In this sense a fee simple is deemed an absolute ownership, in distinction from a fee tail, which is limited in descent. Another distinction was more important, viz.: that while the former could be conveyed or devised, the latter in theory could not be, yet practically it could be alienated by a particular form of proceeding called a common recovery. Yet a fee simple is not necessarily the entire proprietorship, for it may be subject to encumbrances by mortgage or judgment and otherwise; and smaller estates, as a lease for years, may be carved out of it, though in such a case it would be more proper to call the principal estate a fee simple in reversion or remainder. There are also qualified or determinable estates of inheritance, by which is meant that the estate may be determined by some contingency, and yet the contingency may never happen, and therefore by possibility the estate will be perpetual. The illustrations of this species of inheritance are for the most part hypothetical, as to a man and his heirs so long as St. Paul's church shall stand. Sometimes the qualification is residence in a particular place. Or again, there may be a restriction that the person taking the estate shall not marry, an instance of which we have in the case of a devise by a man to his wife on condition that she shall continue a widow. When by the limitation an estate is to last till a certain event, there is until the event happen an inheritance subject to being determined; though if the event become impossible, then the estate is converted into a fee simple absolute. A conveyance by the owner of a determinable fee will of course be subject to the disqualification or contingency upon which the estate depends. It may be a question, in the case of a limitation to a man and his heirs so long as they reside in a certain place, what the effect of alienation would be; but probably the same rule would apply, viz.: that it would be valid to the extent of the right which the grantee him-

self had, but would be defeated by a breach of the condition. If this would be inconsistent with the nature of the estate, the restriction would, it may be presumed, be void under the statutory rule which has been adopted in the state of New York, whereby the power of alienation cannot be suspended by any limitation or condition whatever for a longer period than two lives in being at the creation of the estate. II. An estate for life may be either by express grant or by operation of law. Of the latter kind are dower and curtesy, the respective interests of the wife and husband, each in the lands of the other, in case of survivorship. Estates for life as well as inheritance are included in the common denomination of freehold (*liberum tenementum*); which term seems to have been derived from the ancient mode of conveyance, which was by livery of seisin, that is, delivery of possession according to the form of feudal investiture. Other estates which were of an inferior nature could be transferred without this formality. It was chiefly as a distinction from copyhold estates that the term was used. The copyhold was originally an estate at the mere will of the lord, but became established by prescription, the evidence of which was in the rolls of the courts baron, whence the estate was said to be held by copy of court roll; and although it thus became independent of the will of the lord, it was still deemed a base tenure, and the form of conveyance was by surrender to the lord, and a new grant by him to the alienee, admitting him to be tenant of the copyhold upon the same terms by which the estate had been formerly held. An estate for life may be either for the life of the tenant himself or of another person. The latter is usually designated as an estate *par autre vie*. III. Estates less than freehold are for a term of years, or at will, or by sufferance. The first is for a definite period; but whatever may be the length of the period, even if it should be a thousand years, it is still inferior to a freehold, and is classed in law with chattel interests. Thus, on the death of a tenant, his lease is included with the personal property to be administered as assets, instead of going to the heir. An estate at will was when lands were occupied by the tenant with consent of the landlord, but without any agreement as to the time the tenant shall be permitted to remain. It can hardly be said to exist at present, as the courts now hold a tenancy where no certain term is agreed upon to be from year to year, and reasonable notice must be given of the intention to terminate it. The circumstance that distinguishes the two kinds of tenancy is the reservation of a certain rent, which may be either by express agreement, or by implication from the receipt of rent. If a certain rent is payable, it constitutes an estate from year to year; but if neither rent nor time of occupation is specified, it is a tenancy at will. An estate by sufferance is where the tenant has been in possession by lawful title, but wrong-

fully holds over after the determination of his interest. In such a case the tenant holds by the mere laches of the landlord, and is subject to being turned out by summary proceedings. But any act of the landlord affirming the wrongful holding, as receipt of rent, would convert the naked occupancy into a tenancy from year to year, and is then determinable only at the end of the year. The English statute of frauds (29 Charles II.), which has been generally reenacted in the United States, requires leases for a term of more than one year to be in writing; and in the state of New York and many other states a lease for a term exceeding three years must be recorded, or it will be inoperative against subsequent *bona fide* purchasers. Another distinction in the nature of estates has reference to the time when the right is reducible to possession. The right may exist prospectively, and it is then termed an estate in expectancy. It is of two kinds: one created by the act of parties, and called a remainder; the other by operation of law, and called a reversion. An estate in remainder is what remains after a particular estate, either for years or life, to take effect in possession immediately after such estate, and must be created at the same time, though limited to commence in possession at a future time. Thus if a life estate be granted to A, with remainder to B for life, and remainder to C in fee, here are two remainders to commence in future, and the whole property constitutes but one estate. Yet in ordinary phraseology, where there is but one remainder including the whole residue of the estate, the fee is said to be in the person to whom such limitation is made. An estate in reversion is the residue of an estate left in the grantor or his heirs or in the heirs of a testator after the determination of a particular estate granted or devised. The estate reverts by operation of law, and a reservation to the grantor by the deed would have no effect, being only what the law itself prescribes. A contingent remainder is when the limitation depends upon a contingency which is uncertain or may not occur till after the determination of the particular estate; though it is held that such contingency must not be a remote possibility, as if the limitation should be to the heirs of a child not yet born. A single illustration of this kind of estate will be sufficient. If a grant be made to A for life, with remainder to the heirs of B, and B should survive A, inasmuch as he cannot have heirs while living, the remainder would fail; but if the limitation be to A and B during their joint lives, with remainder to the survivor, here the remainder will take effect, though it is uncertain as to the person who will have the benefit of it. An executory devise is a disposition of an estate by will which would not be valid if made by deed, as a limitation of a contingent remainder. The distinction is that the remainder must take effect immediately upon the determination of the particular estate or not at all; whereas an execu-

tory devise is good without a particular estate to support it. Thus if a devise be made to A, to take effect on his marriage, in this case until such marriage the fee descends to the heir at law, subject to being divested by the performance of the condition. There is still another distinction of estates growing out of the nature of the possession, under which head are classed joint tenancy, tenancy in common, and coparcenary. The last of these, which is a descent of an inheritance to female heirs, in which case they take an equal interest in the entire estate, but without being subject to the rule which applied to joint tenancy as to the right of the survivor to the whole, does not exist in the United States, at least is not distinguishable from a tenancy in common. So joint tenancy, the peculiar feature of which is that the whole estate vests in the survivor, has been abolished in this country, except in respect to executors and other trustees and mortgagees, and except also when it is expressly declared in the deed or will creating the estate that it is to be held in joint tenancy. In all other cases, where there is a possession of lands by several persons without any separation into specific parts, it is a tenancy in common; and it is not necessary that they should all hold by the same title, or have an equal interest; it is sufficient if each has an interest, and that it is undivided. Such an interest can be conveyed or devised, the same as property held in severalty, and partition may be compelled by either party on application to a competent court. Various equitable interests in lands will be discussed in the article TRUSTS. —We have thus far considered estates of a corporeal nature only; but there are also incorporeal estates, such as rents, easements, &c. But the general principles applicable to the one class will also apply to the other; and whatever there may be peculiar to any particular species of incorporeal estate will be treated under the appropriate head.

**ESTE** (anc. *Ateste*), a town of N. Italy, in the province and 16 m. S. W. of the city of Padua, beautifully situated at the foot of Monte Murale or Cero, at the S. extremity of the Euganean hills; pop. about 10,000. It is a mediæval town, with arched houses, and famous for the castle of Este, known as *la rocca*, consisting of a donjon tower with frowning embrasures and battlements, and standing on an elevation upon the site of the original castle of the celebrated house of Este. The church of San Martino, of modern interior and antique exterior, has a belfry which inclines nearly as much as the leaning tower of Pisa. The manufactures of Este include silks, earthenware, majolica, and saltpetre, and there are many whetstone quarries in the neighborhood. The railway station is 3 m. outside the town. The vicinity of Este is celebrated for its picturesque scenery. The ancient *Ateste* was a municipal town as early as 136 B. C.

**ESTE**, a princely house of Italy deriving its name from the town of Este. Alberto Azzo II.

of this family (born in 996, died in 1097) married first Kunitza or Kunigunde, a princess of the Bavarian house of Guelph or Welf. His son by this marriage, Guelfo IV., inherited the possessions of his mother's brother, Guelph or Welf III. From him are descended the houses of Brunswick and Hanover (known also by the name of Este-Guelph) and the sovereigns of Great Britain. Alberto Azzo married for his second wife Garsenda, countess of Maine in France. He had by her two sons, Folco and Hugo. Folco inherited the Italian estates of his father, and transmitted them to his son Obizzo, under whom the foundation was laid for the dominion of the house of Este over Ferrara. This was accomplished by carrying off Marchesella, the sole descendant of the Adelardi family, who had been betrothed to one of the Ghibelline family of Taurello, and compelling her to marry Azzo of Este, the son of Obizzo. The Adelardi family had been the popular leaders of the Guelphs in Ferrara, and the marriage secured to the house of Este the possession of Ferrara and other Italian towns. Azzo VI. (1170–1212) was placed in 1208 at the head of the government of Ferrara, with power to appoint a successor, and was the leader of the Guelphs against Ezzelino, the champion of the Ghibellines. Azzo VII. (1205–'64) defeated Ezzelino, and was hailed as the saviour of Lombardy. Borso, another prince of the house of Este, received in 1452, from the emperor Frederick III., the titles of duke of Modena and Reggio and count of Rovigo, and from Pope Paul II. in 1471 the title of duke of Ferrara. He was distinguished for his patronage of arts and letters. He was succeeded by his brother Ercole I., who was also a patron of literature. Alfonso I., the son of Ercole, married Lucrezia Borgia. The court of Alfonso II., who was the last legitimate prince of the house of Este, was renowned for its splendor. His name, as well as those of his sisters, Lucrezia and Eleonora, are associated with the misfortunes of Tasso. After the death of Alfonso II. (1597) Ferrara was seized by Pope Clement VIII. as a papal fief. The duchies of Modena and Reggio remained in the family, but in 1797 were taken by Bonaparte from its representative, Ercole Rinaldo, and annexed to the Cisalpine republic. The daughter of the latter, Maria Beatrice, married the archduke Ferdinand, third son of Francis I. of Austria.—The name of Este was adopted by the children of the duke of Sussex, sixth son of George III. of England and Lady Augusta Murray. The marriage of the duke of Sussex with Lady Augusta was held by the English prerogative court to have been in violation of the royal marriage act, and was annulled. Augusta Emma d'Este, one of the children of the marriage, married in 1845 Sir Thomas Wilde, afterward Baron Truro. Augustus Frederick d'Este, the other child, a colonel in the army, endeavored without success to obtain recognition as one of the royal family.

**ESTELLA**, a city of Navarre, Spain, on the left bank of the Ega, about 25 m. S. W. of Pamplona; pop. about 6,000. It is situated in a beautiful valley surrounded by hills and planted with vines, olives, and other trees. It has excellent streets and fine squares, and contains an ancient castle, a number of churches, and many public institutions, including a college and an academy of music. There are manufactures of woollen, linen, and silk goods, oil, wine, brandy, earthenware, and leather, and an active trade. Don Carlos, the first pretender of this name, whose headquarters were for a long time in this locality, was proclaimed king here in November, 1833; and in 1839, when he fled to France, a number of his officers were summarily executed at Estella. In the summer of 1873 the Carlists again occupied the town, but on Oct. 5 were compelled to evacuate it by the government troops under Gen. Moriones.

**ESTEPA**, a town of Spain, in the province and about 60 m. E. S. E. of the city of Seville, on the N. side of Mount Francisco; pop. about 7,000. It is tolerably well built, with some large and many small and steep streets, and a number of squares. The church of Santa Maria la Mayor is a Gothic building of alleged Moorish origin. There is an ancient feudal fortress, which was once deemed impregnable on account of its situation on the summit of the mountain which overhangs the town. Coarse cloths and other articles are manufactured, and there are many oil mills.—Estepa is supposed to occupy the site of the ancient Astapa, whose inhabitants in the second Punic war destroyed themselves and their city rather than fall into the hands of the Romans.

**ESTEPONA**, a town of Spain, on the Mediterranean, in the province of Malaga, 25 m. N. E. of Gibraltar; pop. about 9,000. It contains the ruins of an ancient castle and an unusually large number of boarding and day schools. The parish church, built in 1474, is a fine building. The inhabitants are chiefly engaged in the herring fishery and maritime enterprises.

**ESTERHÁZY** (*ESTERHÁZY DE GALÁNTA*; Hun. *Esterházy*), a family of Hungarian magnates, distinguished for their wealth, of whom the first authentic record is dated in 1238. This record mentions the division of the estates of Solomon of Estoras between his two sons, who assumed from their lands the names of Zerházy and Illyésházy. Francis Zerházy was knighted in 1584, and adopted the name of Esterházy of Galántha. His sons Gabriel, Daniel, Paul, and Nicholas became the founders of four lines, of which the first became extinct in 1670, while the others have come down to our day. Of these the lines of Old Zólyom or Altsohl and Csesznek were created counts in 1683, and the line of Fraknó or Forchenstein as early as 1626, through its representative Nicholas Esterházy of Fraknó, who died with the rank of palatine and field marshal in 1645. The two younger sons of the last named, Paul and Francis, be-

came the founders of the line of counts and of the line of princes of the house of Esterházy-Fraknó. The line of counts separated into three branches, all of which are still represented, as are also the Old Zólyom and Csesznek lines. The princely main branch of the house of Esterházy was founded by Paul IV. in 1635, who was created prince in 1687 in reward of his services as general of cavalry and palatine of Hungary. He died in 1713. He was succeeded by Prince Michael, who died in 1721, leaving no male issue. The succession fell to his brother Joseph Antony, who died in the same year. The elder of his two sons, Prince Paul Antony, born in 1711, rose in 1747 to the rank of field marshal lieutenant, was appointed ambassador to Naples in 1750, and died as field marshal in 1762. His brother Nicholas Joseph, born in 1714, attained the rank of field marshal, and had conferred upon him the title of prince, hereditary in both male and female issue. His son, Prince Paul Antony, born in 1738, became lieutenant field marshal, and died in 1794. He was the father of the princes Antony and Nicholas. The latter, born in 1765, served in the army, and subsequently in the diplomatic corps, and gained distinction as a promoter of arts and sciences, and as the founder of a gallery of paintings and engravings. It is said that in 1809 he refused the crown of Hungary offered to him by Napoleon. He died at Como in 1833. His son, Paul Antony, born March 10, 1786, distinguished himself as a diplomatist, chiefly at the court of England; but returning to his native country in 1842, he embraced the national cause, and in 1848, as Hungarian minister of foreign affairs, vainly attempted to bring about a reconciliation between the Austrian court and Hungary, resigning before the dissolution of the Batthyányi ministry. By extraordinary munificence and extravagant displays of wealth, both abroad and at home, he ultimately brought about a legal sequestration of his immense estates. He died May 21, 1866, and was succeeded by his son Nicholas Paul, born June 25, 1817, who married in 1842 Lady Sarah, daughter of George Child Villiers, earl of Jersey. His entailed inheritance in Hungary embraces 29 estates with 21 castles, 60 towns, 414 villages, and 207 other landed possessions; the princely seat is at Eisenstadt. Besides these he is the owner of the domains of Pottenstein and Schwarzbach in Lower Austria, and of Edelstetten in Bavaria.

**ESTHER**, a Persian queen of Jewish descent, wife of Ahasuerus, and also the title of the Biblical book that contains her history, and the narrative of the delivery of the Jews by her from a general massacre throughout the Persian empire. Her original Hebrew name was Hadassah. The book is one of the smallest historical works of the Hebrew Scriptures, and one of the five so-called *Megilloth*, and belongs to the Hagiographa. It is written in correct but somewhat modern Hebrew, and distinguished by some new words, and the total absence of any refer-

ence to God, notwithstanding the providential character of the events related. This has led to the conclusion of some critics, that the book is a translation of or extract from a Persian chronicle, though its authorship has also been attributed to Ezra, Mordecai, and other distinguished Jews. The book narrates how the king, incited by his minister Haman, who was incensed by the independent spirit of the Jew Mordecai, resolved upon the massacre of all the Jews in his dominions, but was turned from his purpose by Esther, who, inspired by Mordecai, saved her nation at the risk of her own life. To commemorate the salvation of their people and the destruction of their enemies, Mordecai and Esther introduced the fast of the 13th of Adar, the day of danger, and the festival of Purim or lots, still celebrated by the Jews on the 14th and 15th of the same month, as days of entertainment and joy, and for sending presents to each other and alms to the poor. On the former of these days the *Megillah* is read in the synagogues. The Persian name of the queen has been differently translated; and that of Ahasuerus is a source of contradictory hypotheses among critics. From the last king of Media down to the last king of Persia, each monarch of that united empire has had his advocate. The claims of Xerxes are best supported by his character; those of Artaxerxes Longimanus, by the authority of the Septuagint and Josephus. The apocryphal additions to the book caused it to be violently attacked by Luther. Among the recent works relating to the book of Esther are: Baugarten, *De Fide Estheræ* (Halle, 1839); Davidson, "Lectures on Esther" (Edinburgh, 1859); and Oppert, *Commentaire . . . d'après la lecture des inscriptions perses* (Paris, 1864).—By a singular coincidence, another Jewess Esther also attracted the love of a gentile king, Casimir the Great of Poland (1333-'70), became his mistress, and was able to protect her people in a time of persecution. She is the heroine of historical novels by Bernatowicz, Bulgarin, Bronikowski, Jósika, and others; and her memory is preserved by the tomb at Lobzów, near Cracow, once her residence.

**ESTHONIA** (Ger. *Esthland*; Esth. *Wiroma*), a government of European Russia, bounded N. by the gulf of Finland, E. by the government of St. Petersburg, S. by Livonia, and W. by the Baltic, in which lie Dagö and some smaller islands belonging to it; area, 7,611 sq. m.; pop. in 1867, 322,668. The inhabitants of the towns and the nobility are chiefly Germans, and the German language is predominant in the administration and in the schools and churches; but the rural population, who constitute a great majority of the people, are Esthonians. The surface is generally low, sandy, rocky, or marshy, and is interspersed with more than 200 lakes, but produces abundantly grains, flax, and pulse. There are many extensive forests of firs and birches. The climate is moist, cold, and salubrious; the winter continues for eight

months, and the transition to summer is sudden. The fisheries are productive; agriculture receives great attention, and the rearing of cattle, and particularly of sheep of the merino and Saxon breeds, is an important interest. Lutheranism is the prevalent religion, but there are also many adherents of the Greek church. The government of Esthonia is divided into the districts of Revel, Hapsal, Weissenstein, and Wesenberg. Capital Revel. Its governor is under the orders of a governor general who resides at Riga, and who has authority also over Livonia and Courland.—The Esthonians, who are also numerous in Livonia and other neighboring governments, are of Finnish descent, of slight stature, daring and vindictive. They embraced Christianity about the beginning of the 13th century, and fell successively under the power of the merchants of Bremen, the Danes, the Teutonic knights, the knights



Esthonian Women.

sword-bearers or Livonian knights, and the bishops of Riga and Semgallia. Threatened in 1555 with conquest by Russia, they preferred to recognize the authority of Eric XIV., king of Sweden, whose successors gave legal sanction to the rights of the Esthonians by various treaties, especially by that of Oliva in 1660. In 1710 the country was conquered by Peter the Great, and was definitely confirmed to Russia by the treaty of Nystadt in 1721. It received the title of grand duchy. There are Esthonian popular songs, naïve and melancholy, versified in the Finnish manner, that is, metrically and alliteratively. The oldest of these is a song of the peasants of the canton of Revel, which has been sung from the time of the introduction of Christianity.

**ESTIENNE**, or *Étienne*, a celebrated French family of printers. See STEPHENS.

**ESTILL**, an E. county of Kentucky, intersected by the Kentucky river; area, about 300 sq. m.; pop. in 1870, 9,198, of whom 599 were colored. It is well supplied with water power, and rich in coal and iron. The surface is uneven or mountainous, and there are many extensive forests. The soil is moderately but not uniformly fertile. The chief productions in 1870 were 7,910 bushels of wheat, 376,792 of Indian corn, 25,642 of oats, 14,095 of potatoes, and 157,580 lbs. of butter. There were 1,956 horses, 1,871 milch cows, 3,029 other cattle, 6,146 sheep, and 8,718 swine; 7 distilleries, 2 saw mills, and 3 manufactories of pig iron. Capital, Irvine.

**ESTOPPEL**, an impediment or bar in law to a right of action or defence, arising from a man's own act or conduct. Estoppels are: 1, by record, which arise where judgment has been rendered by a court of competent jurisdiction, whereby the parties thereto and their privies are for ever precluded from alleging matters which would be contradictory to the record; 2, by deed, which being supposed an instrument of very solemn and deliberative nature, the party executing the same and his privies in law or in estate are not permitted to deny the facts which it evidences; 3, by matter *in pais*, as where a man stands by and sees his own property sold by a third person as the property of the seller, and fails to assert his title at the time, and another buys and pays for the property in good faith, he will be estopped or precluded from alleging his title afterward. In general it may be said that where one by his silence, when good faith required him to speak, has induced another to suppose that a certain state of facts exists, he shall not be allowed afterward to dispute such facts to the prejudice of the party thus deceived by his silence. (See EVIDENCE.)

**ESTOVERS**, a Norman term, equivalent to necessities. The most ordinary use of it was in reference to the right of a tenant of lands to take wood necessary for domestic or farming purposes. In such case it was an exclusive right, and related to wood upon the leased premises. Estovers are also called *botes*, and are classified in the old books as hay or hedge bote (wood for repair of fences), plough bote (wood for ploughs and other farm implements), and house bote (wood for fuel and repair of buildings). There could be also common of estovers, that is to say, a right of taking wood from other lands, either in common with other persons, or as an exclusive privilege appendant to a particular tenement. The alimony of a wife who had obtained a divorce *a mensa et thoro* was formerly called estovers, and could be recovered by a writ *de estoveriis habendis*.

**ESTRAYS**, or *Strays*, domestic animals, usually designated as cattle, which are found wandering in enclosed lands, and whose owner is unknown. In England they belong to the proprietor of the manor on which they are found, provided that after proclamation in the

church and two market towns the owner does not appear to claim them within a year and a day. In the old books estrays were described as *pecus vagans, quod nullus petit, sequitur, vel advocat*; therefore dogs and cats were not included; a swan might be, but no other fowl. In the United States the regulation of estrays is by statute, and cattle at large in the public streets contrary to local regulations are included. They are allowed to be detained, and after a certain time and on proper notice, if not reclaimed, they are sold by public auction for the costs of keeping and sale.

**ESTREAT** (Lat. *extractum*; mediæval Fr. *estrete*), a term still in use in criminal proceedings, by which is signified the extracting or taking out a record of a court for prosecution in another court, or it may be in the same court. To estreat a recognizance is to indorse it by order of the court for prosecution. The use of the term probably grew out of the custom in England of sending all recognizances to the court of exchequer to be prosecuted.

**ESTREES, Gabrielle d'**, mistress of Henry IV. of France, born in 1571, died April 10, 1599. Her father and mother were of noble birth. Gabrielle, who possessed remarkable beauty, was but 16 years old when her mother introduced her to the notice of Henry III.; but she retained his favor only a short time. She soon became well known for the number and rank of her lovers, among whom were the cardinal de Guise and the dukes de Bellegarde and Longueville. In 1590 she met Henry IV. for the first time at the château of Cœuvres, where she resided with her family. She inspired the monarch with a violent passion, which, however, did not interrupt her relation with her old lover, the duke de Bellegarde. The king caused her to take M. de Liancourt for her nominal husband, but subsequently divorced her, and raised her to the rank of marchioness of Monceaux, and in 1595 to that of duchess of Beaufort. He lavished riches upon her in great profusion, and at the time of her death she was the owner of more than a dozen estates, some of which are still pointed out in the vicinity of Paris. Her extravagance was unbounded. Henry would have divorced himself (as he afterward did) from Margaret of Valois, his legitimate wife, for the purpose of raising Gabrielle to the throne of France, if it had not been for his minister and friend Sully, who was the only person with whose influence she was unable to cope. Even this Henry appeared inclined to override, when the sudden death of Gabrielle, which many believed to have been caused by poison, ended the matter. She had three children by the king.

**ESTRELLA, Serra da.** See PORTUGAL.

**ESTREMADURA. I.** A province of Portugal, on the W. side of the kingdom, between Beira, Alemtejo, and the Atlantic ocean; area, 6,872 sq. m.; pop. in 1868, 837,451. It contains the cities of Lisbon and Leiria. It is mountainous, being traversed by the Serra da



Estrella and its S. W. continuations. Its soil is watered by numerous streams, the principal of which are the Tagus and the Sadão. Grains, fruits, and wines are produced. It has suffered from earthquakes, and has unexplored mines. II. An old province of Spain, in the W. part of the peninsula, comprising the modern provinces of Badajoz and Cáceres, bounded N. by Salamanca, N. E. by Ávila, E. by Toledo, Ciudad Real, and Cordova, S. by Seville and Huelva, and W. by Portugal; area, 16,693 sq. m.; pop. in 1867, 733,749. It is entirely surrounded by mountains, and is divided into three parts by the rivers Tagus and Guadiana, and into two parts by the mountains of Guadalupe, San Pedro, and San Mamed. These mountains, forming but a single chain, traverse the province from E. to W., and nearly form the boundary between its two present divisions. The soil of Estremadura is very fertile, and if well cultivated would produce sufficient to support a third of the population of Spain; but nearly all the large proprietors reserve their lands for pasturage. A little barley and wheat are cultivated, and chestnuts are abundant, forming the principal food of the inhabitants. This province is distant from the sea, and has no great highways. Even its rivers are little used for navigation. Its manufactures are of no importance, and its mines of lead, silver, and coal are neglected. It was formerly a part of the kingdom of Leon, and was the last province conquered by Alfonso IX. of that kingdom; whence the name of Estremadura, from Lat. *extrema ora*, last region.

**ESTREMOZ**, a town of Portugal, in the province of Alemtejo, 22 m. W. of Elvas; pop. about 6,600. The fortifications, once strong, are fast decaying. Pottery and leather are manufactured, and in the vicinity are marble quarries.

**ESZÉK**, or *Esseg* (Slav. *Osjék*), a town and fortress of the Austro-Hungarian empire, capital of Slavonia, in the county of Verőce, on the Drave, 13 m. from its confluence with the Danube, and 135 m. S. by W. of Pesth; pop. in 1869, 17,247. Fairs for cattle, corn, and other produce are held here four times a year. Of late the population and industry of the town have rapidly increased, the Drave having been made available for steamboat navigation. The fortress contains an arsenal and barracks for 30,000 men; during the revolutionary period of 1848-'9, it was occupied by the Hungarians until Feb. 14, 1849, when it surrendered to the Austrian Gen. Trebersberg. Not far from Eszék stand the famous bridges constructed by Solyman II. in 1566, to facilitate the entrance of the Turkish armies into Hungary. The town was a colony of the Romans, who called it Mursa; and it afterward became the residence of the Roman governors of Lower Pannonia.

**ÉTAMPES** (under the Franks, *Stampæ*), a town of France, in the department of Seine-et-Oise, 28 m. S. by W. of Paris; pop. in 1866, 8,228. It is on two small tributaries of the Juine, or Étampes, in a fertile valley, and is surrounded

with shady promenades. It has a ruined tower called Guinette, the only remnant of the ancient castle built by King Robert in the 11th century. There are several fine churches, a town hall, and a castle which is said to have been given in apanage to the duchess d'Étampes and other royal favorites. There is also a statue of Geoffroy-Saint-Hilaire, the naturalist, who was born here. The chief manufactures are soap, leather, counterpanes, woollen yarn, and hosiery. A considerable trade is carried on in wool, corn, honey, and flour, and there are more than 40 mills.

**ÉTAMPES**, *Anne de Pisseleu*, duchess d', a mistress of Francis I. of France, born about 1508, died about 1576. Her father, Guillaume de Pisseleu, was a country gentleman of Picardy. Anne was a maid of honor of the queen regent, when in 1526 she attracted the attention of her son Francis I. She became his favorite mistress, displacing the countess de Chateaubriant; he gave her for a nominal husband Jean de Brosse, afterward duke d'Étampes. The new duchess secured lucrative appointments for her relatives and friends, and wielded a paramount influence in the affairs of the nation. Upon the fine arts and in some other directions her influence was good, but the jealousy which sprung up between her and Diana of Poitiers, the mistress of the dauphin Henry, eventually became a source of calamity for her lover and for France. It was chiefly under the influence of this feeling that she betrayed to Charles V. the movements of the French army; and the disadvantageous treaty of Crespy in 1544 was due to the intrigues of Anne and of Diana. Anne was present in 1538 at the interview between Francis I. and Charles V., and according to the chroniclers of the times the emperor was fascinated by her beauty. The death of Francis (1547) proved fatal to her power. Henry II. banished her from the court, and she ended her days on one of her estates. It is said that she devoted herself to religion, and became a Protestant.

**ETAWAH**, a town of British India, the capital of a district of the same name, on high ground about 1 m. from the left bank of the Jumna, 80 m. W. by N. of Cawnpore, and 60 m. S. E. of Agra; pop. about 25,000. Ghauts, or flights of steps, some in ruins, others new and frequented by Hindoo devotees for religious ablutions, lead toward the river, across which is a ferry and at times a bridge of boats. A fort and a large jail are the principal buildings. The town was prosperous and important under the Mogul empire, but is now little more than a mass of ruins, and is generally described as one of the least attractive stations in India. It has some commercial consequence from its position at the junction of the roads from Calpee and Cawnpore to Agra, and contains a few bungalows and other military buildings.

**ETECHEMINS**, a tribe of Indians occupying the eastern part of the state of Maine, now represented by the Penobscots and Passamaquoddies. They lived chiefly in early times on

the St. Croix, and were between the Abenaki proper and the Miamaes, though in later times they were generally treated as part of the Abenaki nation. They now number about 1,000, half of them Penobscots on islands in the river of that name, and the remainder Passamaquoddies on the western shore of the bay of that name and on the Schoodic lakes. They are Roman Catholics, and have churches and schools, and a fund arising from land sold to the state; but they are declining from intestine divisions, and from the intermarriage of near kindred, the laws of Maine not permitting an Indian to marry a white.

**ETEOCLES and POLYNICES**, mythical kings of Grecian Thebes, sons of Œdipus and Jocaste. After the flight of their father, the brothers agreed to govern the kingdom alternately; but Eteocles refusing on the expiration of his term to surrender the sceptre, Polynices retired to the court of Adrastus, king of Argos, who gave him one of his daughters in marriage, and undertook to sustain him in the enforcement of his rights. They organized that confederacy of Peloponnesian chiefs whom Æschylus has immortalized, and whose expedition, undertaken to restore Polynices, is known as that of "the seven against Thebes." In the sieges which followed the success of the belligerents was various, and many warriors were slain, when the brothers, to prevent further effusion of blood, resolved to decide the contest by single combat, in which both perished. (See ANTIGONE.)

**ETESIAN WINDS** (Gr. *ἐτησίαι*, from *ἔτος*, year), the name given by the ancients to the N.E. trade winds which blow for about six weeks during the summer throughout the countries adjacent to the Mediterranean, especially its eastern portion. On the sea they are called by the fishermen *meltem*, probably from *mal temps*, in reference to the fury with which they blow, and the dangerous weather which they create for their small craft. On land they are equally salutary to men, beasts, and birds, and likewise beneficial to vegetation, by moderating the violent heat of the weather during the season of the dog days. In the Levant they commence toward the middle of July about 9 in the morning, continuing only in the daytime. The sun at that season is powerfully heating the surface under the tropic of Cancer, and rarefying the atmosphere south of the Mediterranean. Currents of air are thus drawn in over the desert of Sahara; but though in their passage across the Mediterranean they must become charged with moisture, the clouds are dispersed as they pass the margin of the hot sands, and the vapor dissipated in the rarefied air is swept on, to be again collected together and precipitated in a cooler region.

**ÉTEX, Antoine**, a French sculptor, painter, and architect, born in Paris, March 20, 1808. He studied under Ingres, and after the production in 1829 of his "Ilyacinth killed by Apollo," he spent some time in Italy and visited other

countries at the expense of government. Returning to Paris, he exhibited in 1833 a colossal group of "Cain," which procured him orders from the government, and he has since produced many statues and architectural designs. He also excels as a painter and draughtsman. In 1864 he exhibited paintings entitled "The Ancient Slave" and "The Modern Slave." He has published *Essai sur le beau* (Paris, 1851), and *Cours élémentaire de dessin* (3d ed., 1859).

**ETHELBALD**, king of Wessex, son of Ethelwulf, king of the Anglo-Saxons, obtained the throne of Wessex, about 856, and died in 860. While Ethelwulf was making a journey to Rome, on his way back from which he married Judith, the young daughter of the French monarch, Ethelbald formed the project of seizing the throne. A civil war was prevented only by the moderation of Ethelwulf, who resigned to his son the dominion of Wessex, and confirmed that portion of the kingdom to him in his will. The reign of Ethelbald was peaceful, but he excited general disapprobation by marrying, contrary to the canonical law, his step-mother Judith. Ecclesiastical and popular displeasure forced him to a separation, and Judith returning to France eloped from a convent with Baldwin, called *Bras de Fer*, afterward count of Flanders. From this union descended Matilda, wife of William the Conqueror, and through her of the race of English sovereigns.

**ETHELBERT**, king of Kent, born about 545, ascended the throne in 560, and died in 616. As the representative of Hengist, he claimed superiority among the Saxon states, but was twice defeated in the early part of his reign by Ceawlin, king of Wessex. About 589 he had acquired the dignity of bretwalda, or leading chief of the Anglo-Saxons, Ceawlin being deposed by his subjects, and dying a few years later. The most remarkable event of his reign was the introduction of the Christian religion into Britain. His queen Bertha, a daughter of Charibert, king of Paris, professed this faith, and through her it had already become somewhat known to the king and to a portion of the people, when in 596 a company of Italian and French monks, sent by Pope Gregory the Great, under the conduct of Augustin, landed on the isle of Thanet. They were received by the king beneath an oak, the sacred tree of the druids, where it was supposed any magical spell would be without influence; and after a conference he gave them permission to preach without molestation, though he himself had then no intention of abandoning the gods of his fathers. The queen prepared a residence for the new apostles, and in 597 Ethelbert received the sacrament of baptism, and his example was followed by 10,000 of his subjects. About 600 he issued the earliest remaining code of Anglo-Saxon laws, consisting of 89 enactments, relating principally to the amount of pecuniary fines payable for various transgressions.

**ETHELBERT**, third king of the Anglo-Saxons, son of Ethelwulf, died in 865 or 866. He in-

herited in 857 all the kingdom excepting Wessex, and on the death of his brother Ethelbald in 860 possessed himself also of that portion. During his reign the Northmen sacked the city of Winchester, landed on the isle of Thanet, pillaged a part of Kent, and appeared in Northumbria under Ragnar Lodbrog.

**ETHELRED** (also written **EDELRED** and **ETHELRED**) **I.**, fourth king of the Anglo-Saxons, son of Ethelwulf, and successor of his brother Ethelbert, ascended the throne in 866, and died in 871. His reign was a continuous struggle against the Northmen. The sons of the Danish chieftain Ragnar, whom the Northumbrians had put to death, appeared in East Anglia, took possession of the city of York, and defeated and slew two Northumbrian princes who attempted to recover it. Marching southward they took up their winter quarters at Nottingham, whence they retired without a battle after being for some time beleaguered by Ethelred and his brother Alfred. Passing into East Anglia, they burned on their way the monasteries of Bardney, Croyland, and Medeshamstede, ravaged the nunnery of Ely, and seized and murdered the East Anglian king Edmund, who was hence revered as a martyr. They were met in 871 by Ethelred and Alfred at Reading, but were able to maintain their ground. Being attacked by Alfred four days later at Æscesdun, they were routed and were pursued for a night and a day. Within a fortnight another battle was fought at Basing, in which the invaders were victorious, and an obstinate engagement soon followed at Merton. Ethelred died of a wound, and left the kingdom to Alfred.

**ETHELRED II.**, surnamed the Unready, king of the Anglo-Saxons, son of Edgar and successor of Edward the Martyr, born in 968, ascended the throne April 14, 978, and died in London, April 23, 1016. His reign was long, and the most unfortunate in Anglo-Saxon history. The son of that Elfrida whose criminal ambition had caused the tragic death of the late king, he never possessed the affections of his subjects, and was acknowledged only because there was no other prince of the royal blood. The Danes made several invasions, appeared with a formidable armament in 991 off the coast of Essex, took Ipswich, and advanced into the country. They were met at Maldon by Brithnoth, ealdorman of that country, who, after having foiled their efforts for 14 days, was defeated and slain. The king, listening to the advice of Siric, archbishop of Canterbury, and many of the nobility, purchased the departure of the enemy by paying them 10,000 pounds of silver, collected by an oppressive tax on landed property, which from this time was permanently established under the name of Danegelt. A fleet fitted out against them was rendered useless by the treachery of Alfric, its commander, who afterward deserted to the enemy. In 993 the Danes, joined by three chieftains who were sent to oppose them, captured the castle of Bambor-

ough and ravaged both sides of the Humber. In 994 the Northmen, under the command of Sweyn, king of Denmark, and Olaf, king of Norway, attacked the centre of the kingdom, sailed up the Thames, and laid siege to London, from which being repulsed, they plundered Essex, Sussex, and Hampshire, and having obtained horses were spreading devastation far into the inland counties. The forbearance of the invaders was now purchased by the payment of 16,000 pounds, and in 1001 of 24,000 pounds of silver. Ethelred and his advisers then determined to rid themselves of the Danes by a general massacre. Secret orders were sent to every town and county, and on Nov. 13, 1002, the festival of St. Brice, multitudes of every age and sex were butchered. Next year Sweyn reappeared on the south coast, and from this time left the kingdom no rest, devastating the country from Exeter to the heart of Wiltshire, burning cities and villages. He consented to a peace in 1007 on payment of 36,000 pounds. Soon the war began again, and was again momentarily ended in 1012 by the payment of 48,000 pounds. In 1013 Sweyn openly declared his purpose of conquering England, landed at Gainsborough, and marched triumphantly to the walls of London. Repulsed from the capital, he marched to Bath, where he was proclaimed king of England, and recognized by the thanes of Wessex, Mercia, and Northumbria. Ethelred fled in haste to Normandy, and found an asylum with his brother-in-law Richard, the Norman duke. The death of Sweyn two or three weeks later recalled the fugitive monarch, who, restored to power by the renewed allegiance of those tributary rulers who had deserted him, is said to have inflicted new cruelties upon the Danish population. Canute, the Danish successor, was roused by these atrocities to renewed efforts to subdue England. In 1015 he once more reduced a great part of it to submission, and had advanced on London when Ethelred died, just as preparations were making to attack the city.

**ETHELWULF**, second king of the Anglo-Saxons, son and successor of Egbert, ascended the throne about 836, and died in 857 or 858. He began his reign by transferring the provinces of Kent, Essex, and Sussex to the government of his eldest son Athelstan. For many years he waged incessant contests with the Danes, who annually made inroads into England, and though repulsed and defeated always carried off booty. In 850-'51 a part of them dared for the first time to pass the winter in England. Strongly reinforced in the spring, they sailed up the Thames, sacked Canterbury and London, and met Ethelwulf at the head of the West Saxons at Okely. After an obstinate battle the Danes were defeated with a loss greater, it is said, than they had ever before suffered, and other divisions of their forces were defeated by Georle in Devonshire, and by Athelstan at sea. Yet they maintained their settlement on the isle of Thanet, but were cautious during the re-

mainder of Ethelwulf's reign. In 853 the king marched against the Welsh, and reduced them to subjection. Shortly afterward he made a visit to Rome, accompanied by his son Alfred, who there received the regal unction and the sacrament of confirmation. He returned through France, where he tarried to marry Judith, daughter of the French king. His son Athelstan meantime had died, and Ethelbald was usurping the kingdom, when he returned and yielded to the latter the government of Wessex. He survived this partition only two years, which he passed in charity and devotion.

**ETHER**, or **Æther** (Gr. *αιθήρ*, the upper air, from *αἶθερ*, to burn), in physics, a hypothetical fluid of great tenuity, which by ancient as well as by modern philosophers has been supposed to occupy all space; hence called the cosmic or luminiferous ether. Among the ancient Greeks it was the personified idea of cosmic material as well as force. According to Hesiod, Æther was the son of Erebus and Night and brother of Day. The children of Æther and Day were the heavens, the land, and the sea, from which we are naturally led to conclude that it was considered one of the elementary substances out of which the universe was formed. In the Orphic hymns Æther is represented as the soul of the world, from which all life emanates. Anaxagoras called ether the principle of fire, and Plato described it as a matter purer and lighter than air, which being diffused throughout space, it would be impossible to ascertain if it had weight. The modern ideas of the interstellar ether differ in many respects from those of the ancients, and have assumed a more precise and scientific form; but the speculations of the old philosophers seem to be a foreshadowing of modern theories. Descartes, in his treatise on dioptrics, entertains the idea of an ether, or a "subtile medium" for the transmission of light, which he believed to be "a certain motion or most rapid and lively action coming toward the eye." Huygens was the first to give system and mathematical order to the theory. He conceived that from every point of a luminous body undulations are propagated through an ethereal fluid diffused throughout space, which possesses the property of extreme tenuity and infinite elasticity, and by the most refined mathematical demonstrations accounted for so many of the phenomena of light as to lay the broadest foundations for the subsequent labors of his followers. Newton did not accept the undulatory theory of light, although in the 22d query of his third book of optics he does propound the question as to whether vision may not be caused by a propagation through the fibres of the optic nerve of vibrations communicated by an ethereal medium, thereby stating his belief in the existence of such a medium, as he also does when treating of the subject of heat. His theory that light is caused by the emission of luminous corpuscles from all incandescent bodies was so generally accepted for more than 100

years, that the doctrine of a luminiferous ether, which seems to have been generally considered as peculiarly a fundamental part of the theory of Huygens, did not occupy much attention until the investigations of Young, Fresnel, Euler, and Cauchy placed the undulatory theory of light in the position of a demonstrated fact. The luminiferous ether is now supposed not only to occupy all space between the heavenly bodies, but to permeate all ponderable matter, and to move in undulations between its particles, which undulations may be modified by the nature of the matter, and transformed into heat or other force. It is supposed to be uninfluenced by gravitation, to preserve a uniform density when not contained within the interstices of ponderable bodies, and has also been supposed to offer no resistance to their passage; but the diminution in the periodical revolution of some of the comets, as Encke's, has been ascribed to a retardation possibly due to the resistance of interstellar ether. From being at first considered as a medium for the transmission of light, it has within the last half century, upon the undulatory theory, been adopted as that of heat also, since it has been demonstrated that both heat and light are the effects of undulations of different amplitudes; and at the present time the question is raised as to whether it may not also be the medium, or at least an important agent, in the manifestation of electricity, since this force is now regarded as a correlation of light and heat. It must be observed that Euler maintained only the doctrine of undulations, and rejected that of an ethereal medium, as do several physicists of to-day, among whom is Prof. Grove, contending that the undulations are produced in the ponderable matter, whatever it may be, which constitutes the medium of transmission. The arguments of these philosophers are stated by Prof. Grove in his work on the "Correlation of Physical Forces." Among them may be briefly noted the following: It has been impossible hitherto to produce a perfect vacuum; in other words, to create a space which shall be void of ponderable matter. The tendency of the particles of bodies to fly from their surfaces, even under ordinary circumstances, is so great that the odor of many metals, as iron, copper, tin, and zinc, is always plainly perceptible. Water in a vessel within the exhausted receiver of an air pump will acquire a taste of the tallow used between the edge of the receiver and the pump plate. The tendency of gaseous matter to fly off into space is so great that it is contended that no interstellar vacuum could continue for an unlimited time. Another argument is that light is lost in the interstellar spaces; for if not, all the stars being suns, there ought to be no night. To account for this loss, the light must be supposed to be transmuted into another force, and this requires the intervention of matter, which is believed to be furnished by the mingling of

portions of the atmospheres of worlds in the interstellar spaces; and the retardation of comets has been ascribed to this matter. This argument is not affected by the law that light decreases in proportion to the square of the distance, because, although the rays diverge in all directions from every source, the field of the heavens, as Prof. Grove remarks, is everywhere studded with suns, so that the sum of the rays which would reach the earth, if they retained their luminous property, would furnish more light than is actually received. Again, when as near an approach to a vacuum as is possible has been formed, it has been found to offer an effectual barrier to the passage of the electric spark; and regarding electricity as a correlation of light and heat, it is asked why it will not employ the ethereal medium which upon that hypothesis must pervade the vacuum. This objection loses weight from the fact that the space which contains no medium for the transmission of electricity, nevertheless offers one for the transmission of light and heat. The difficulty of accounting for the polarization of light by assuming that the undulations take place in the molecules of the polarizing body, is greatly diminished by adopting the doctrine of a special medium, as the luminiferous ether. A further consideration of the subject will be found in the articles LIGHT and HEAT. (See also ELASTICITY.)

**ETHER**, in chemistry, the name given to a class of highly volatile, inflammable, spirituous liquids, possessing a sweetish taste and peculiar fragrance, obtained commonly by distilling alcohol in mixture with some acid. Their composition is somewhat variable according to the acid employed in their preparation, and this gives them their distinctive names, as sulphuric ether, nitric ether, &c. Yet these acids do not in all cases furnish any of the ingredients of the ether, and the same ether may sometimes be produced by the action of other substances upon alcohol, as well as of the acid usually employed. This is especially the case with sulphuric ether, and as it contains no sulphuric acid, and is by far the most common form of ether, it is now admitted into the United States and London pharmacopœias by the name of æther, as it was before known in common use. This ether, it is supposed, was known to Raymond Lully, who lived in the 13th century. Valerius Cordus in 1540 described the method of making it. Frobenius in 1730 first brought it prominently forward in a paper published in the "Philosophical Transactions;" and by a note appended to this, it appears that Boyle and Newton had both directed their attention to it.—The preparation of ether was formerly conducted by distilling in a glass retort a mixture of equal parts of sulphuric acid and alcohol at a moderate heat, and, when about one third of the whole had come over, adding half as much alcohol as before, and again distilling. But a better method is to conduct the process on a larger

scale with the use of a leaden still heated by high steam passed through in a spiral pipe; and the alcohol is best introduced in small quantities at a time by a pipe which passes through the upper part of the still. Such is the apparatus used at the apothecaries' hall, London. The heating by steam obviates the danger of explosion, to which the process is liable when the vapors that escape come in contact with a flame. The apparatus given by Brande is convenient either on a large or small scale. In a glass flask are introduced 8 parts by weight of concentrated sulphuric acid and 5 parts of spirit of wine of specific gravity 0.834. This is set in a small sand bath, which may be conveniently heated by a gas light. A thermometer graduated at least to 320° F. passes through the cork, the bulb being in the liquid. There is also a tube reaching to the bottom, and expanding at top into a funnel. This is intended to receive more alcohol slowly dropped into it as the process goes on. A glass tube of large bore conveys the vapor through the condenser, which is surrounded with cold water, and the liquid drops from the end of the tube into a proper receiver. By keeping the temperature as nearly as possible to 300°, the ebullition goes on rapidly, and the quantity of liquid in the flask may be kept nearly the same for several hours, the alcohol as fast as it is admitted being converted into the vapor of ether and of water. These condense together, but in the receiving vessel they separate, the water sinking to the bottom together with  $\frac{1}{10}$  of its volume of ether dissolved in it. If a weak acid be used or too much alcohol, so that the boiling point of the mixture is reduced below 260°, the alcohol is apt to pass over unchanged. It is important to keep up a rapid, or even violent boiling, at a temperature between 260° and 310°. At about 320° olefiant gas and other undesirable products are generated. By the continuous process of Dr. Brande, a small quantity of sulphuric acid may be made to convert into ether a large quantity of alcohol. It might serve for an indefinite time but for its slow volatilization and the passing over of its vapor with the others. Ether is purified by shaking it in a close vessel with twice its bulk of water. After standing, the ether is poured off, and the water that may be still present is taken up by mixing quicklime with it. Then by distilling, pure ether is obtained.—Ether is remarkable for its great volatility. Its vapor escapes in pouring the fluid from one vessel into another, so that if a lighted candle is near there is danger of the whole being suddenly inflamed. A mixture of 10 volumes of oxygen and one of ether vapor explodes violently by an electric spark. The vapor is so much more dense than air, being as 2.58 to 1, that it can be poured out of one vessel into another, displacing the air in this, and showing its presence by taking fire on the application of a match. Its rapid evaporation produces in-

tense cold; a few drops being made to cover a drop of water and then blown upon through a tube, the water is frozen directly. Ether itself, however, does not freeze, even at  $166^{\circ}$  below zero. Its boiling point varies with the nature of the vessel containing it; at the ordinary pressure it boils at  $96.5^{\circ}$ . Its specific gravity at  $68^{\circ}$  is 0.713. It has neither an acid nor alkaline reaction; but after being exposed to the air and light, a little acetic acid is formed in it. Ether unites with alcohol in all proportions. It takes up  $\frac{1}{10}$  of its volume of water, and water does the same of ether. If water dissolve more than this, the ether may be suspected of being adulterated with water and alcohol. The ultimate constituents of sulphuric ether are carbon 4 equivalents, hydrogen 10, and oxygen 1, or  $C_4H_{10}O$ . The radical ethyle consists of  $C_2H_5$ , and ether is regarded as its oxide, alcohol as its hydrated oxide.—Various preparations of ether are largely employed in medicine, surgery, and obstetrics. When administered by the stomach they are stimulant and antispasmodic. Some of them have been used in fevers and nervous affections, and in other diseases to relieve spasm, nausea, and vomiting. Ether has also been administered to remove intestinal worms, which it is supposed to stupefy and cause to relax their hold. By far the most important preparation of ether is the concentrated sulphuric ether, used by inhalation to produce anaesthesia and muscular relaxation. It is indicated whenever these objects are to be attained, as in the case of operations, surgical and obstetric, in hernia, stricture, dislocations, fractures, neuralgia, tetanus, dysmenorrhœa, colic, convulsions, feigned diseases, &c. The use of ether by inhalation to produce intoxication and to relieve pulmonary distress was known long before its anæsthetic properties were discovered. These were first practically demonstrated Oct. 16, 1846, when sulphuric ether was administered by Dr. Morton at the Massachusetts general hospital in Boston to a patient upon whom an operation was performed by Dr. J. C. Warren. (See ANÆSTHETICS.) The action of ether is very similar to that of chloroform. It is possible to produce death by asphyxia with an overwhelming amount and reckless use of ether, although even this is not easy; but it is difficult if not impossible to find a single instance of death which can fairly be attributed to the effects of the drug when used in a moderately careful manner. This is in marked contrast with the results obtained from the inhalation of chloroform, a fact at last acknowledged by many of those who have heretofore employed the latter. The deaths from chloroform, which experience shows to occur even with the most careful administration, and which appear to depend upon a rapidly developed paralysis of the respiratory centres in the medulla oblongata or upon sudden paralysis of the heart, do not happen with ether. The best and simplest method of administering

ether by inhalation is to pour it upon a sponge or towel, and then apply the latter over the mouth and nose. At first the sponge should be held a few inches from the mouth so as to allow a free mixture of atmospheric air; as soon as the patient gets over the primary sensation of choking or suffocation, fresh ether may be added and carried close to and over, but not on, the mouth and nose. Ether is so inflammable that a light should not be brought near to it. The inhalation may be kept up with safety for hours if necessary. Ether may be used externally to produce cooling by its rapid evaporation. If applied in the form of a spray, by means of an "atomizer," the skin may be frozen so that small surgical operations may be performed without pain. For this purpose, however, it has been nearly superseded by a light coal oil of low boiling point, called rhigolene.—Several of the ethers exist in fruits, giving them their peculiar flavors; and the alcoholic liquors distilled from these fruits retain these principles in combination with some acid. Thus cœnanthic ether combined with cœnanthic acid forms the oil which contains the fragrance of brandy and some other spirits.

**ETHEREGE**, or **Etheridge**, Sir George, an English comic author, born about 1636, died about 1690. He studied at the university of Cambridge, travelled on the continent, abandoned law for literature, and became known as one of the wits and libertines of the reign of Charles II. His comedies entitled "The Comical Revenge, or Love in a Tub," "She Would if She Could," and "The Man of Mode, or Sir Fopling Flutter," are marked by a sprightlier and wittier dialogue than had before been displayed in the English comic drama. The author was an associate of Buckingham, Rochester, and other gay courtiers and pleasure-seekers of the time, and he introduced upon the stage the manners and characters with which he was familiar. He also wrote a few coarse songs and lampoons. He lived licentiously, wasted his fortune, and died by falling down stairs after a debauch.

**ETHERIDGE**, John Wesley, an English clergyman, born at Youngwoods, Isle of Wight, Feb. 24, 1804, died May 24, 1866. After a careful education, chiefly under his father's direction, he entered upon the work of the Methodist ministry, and in 1827 was stationed at Hull. Through failing health he became a supernumerary in 1838. In 1843 he took up his residence in Paris, and pursued his oriental studies through the aid furnished by the great public libraries of that city, and under the special instruction of M. Quatremère and the abbé Bargès. In 1845 he became pastor of the mission Methodist church in Boulogne. On the recovery of his health in 1847 he returned to England, and occupied some of the most important stations of the British conference till his death. Among his numerous writings are: *Horæ Aramaicæ* (12mo, London, 1843); "The

Syrian Churches, their early History, Liturgies, and Literature" (1849); "The Apostolic Acts and Epistles, from the Peshito" (1849); "Jerusalem and Tiberias, a Survey of the Religious and Scholastic Learning of the Jews" (1856); and "The Targums of Onkelos and Jonathan ben Uzziel" (1862).

**ETHICS.** See MORAL PHILOSOPHY.

**ETHIOPIA** (Gr. *Aiθιοπία*, from *αἶθεν*, to burn, and *ὤψ*, countenance), an ancient country of Africa, south of Egypt. The name was also used by the Greeks as an ethnic designation of all dark-complexioned races in Africa and Asia. The tribes most frequently mentioned were the Blemmyes, Megabari, Ichthyophagi or fish-eaters, Macrobian or long-lived, and Troglodytæ or cave-dwellers. As late as the time of Darius we find "Ethiopians of Asia" forming part of the 17th satrapy.—Ethiopia proper was bounded N. by Egypt, W. by the desert of Bahiuda, E. by the river Astaboras, and S. by the districts above the modern city of Khartoum, at the junction of the Blue river and the White Nile. In a wider sense, ancient geographers designated as Ethiopia the whole region between the Red sea and the Atlantic ocean, S. of Libya and Egypt. Pliny divides it by the Nile into East and West Ethiopia. Ethiopia proper included the state of Meroë, which was probably centred in the modern Sennaar; and as the city of Meroë became the capital of the land during the Meroë dynasty, the whole of Ethiopia was sometimes spoken of as the kingdom of Meroë. Another Ethiopian capital was Napata, which was probably in the neighborhood of Mount Barkal; but there is reason for supposing that this word designated a movable royal residence rather than a fixed locality.—The early history of the country is obscure. About 3,000 years before our era a considerable branch of the Cushite race, who had probably dwelt in Hedjaz, Arabia, crossed the Red sea, and settled in Ethiopia, the land of Napata and Meroë, till then inhabited by negroes. These regions of the upper Nile were from that time designated as the land of Cush. (See CUSH.) Other Cushites, called Sabeans, established themselves further south on the coast of Africa, opposite Yemen. The northern Cushites soon mixed with the negroes and Egyptians, and acquired peculiarities in type and language which separated them from the kindred race on the coast. As early as the 12th Egyptian dynasty (about 3000–2850 B. C.) they seem to have grown dangerous to the Egyptians, as the fortresses of Kumneh and Semneh were built near the second cataract of the Nile to oppose them. Several steles recently found show that Osortasen III. conquered them, and in the tomb of Ameni, one of his generals, is an account of the campaign and his subsequent administration of the new province. The Ethiopian history of the thousand years following has not yet come to light. During the 17th century B. C. (according to the chronology of Mariette), the

Ethiopians were again at war with the Egyptians. Amen-hotep I. (Amenophis) was not as successful as Thothmes I., his successor, who left a description of his exploits on the rocks on the banks of the Nile, opposite the island of Tombos, about lat. 19° 30' N. The Ethiopians remained quiet for about two centuries, but rebelled again at the beginning of the 15th century, and were subdued by Har-em-Hebi, who, according to an inscription at Silsilis, "chastised the land of Cush as he had promised his father." In the time of Rameses II. the Ethiopians revolted again, and with them the negro tribes of Libya that had been subject to Egypt; but after long and bloody wars they were again subdued. In the subsequent period the country was nearly every year invaded by the Egyptians, who came on a sort of slave-hunting expedition, and carried away thousands of every age and of both sexes. At the invasion of Egypt by the descendants of the shepherds, Merneptah (1341–1321 B. C.) sought with 300,000 men an asylum in Ethiopia, and remained there till his son Seti II., 20 years later, regained the throne. The Ethiopian king Azerkh-Amen (the Zerah of Scripture) invaded Egypt during the reign of Uasarken I. (or of Uasarken II.), and penetrated into Palestine, where he was finally conquered about 941 by Asa, king of Judah. His defeat was so complete that he seems not even to have maintained his position in Egypt, but to have retired at once to his kingdom. Two centuries later, however, the kings of Ethiopia gained the crown of Egypt. Shabaka, the Sabaco of the Greeks and the So of the Bible, conquered all Egypt to the Mediterranean, and burned alive the king Bokenranf. Shabaka was subsequently called on by Hoshea, king of Israel, for assistance against the Assyrians; but he started too late to save Samaria, though an inscription at Karnak names Syria as tributary to him. A little later Tahraka (Tirhakah) successfully fought the army of Sennacherib, but warded off the danger for a short time only, for Esarhaddon entered Egypt and conquered him near Memphis. Esarhaddon remained two years in the country, and entitled himself "king of Egypt and Ethiopia" (669). Tahraka reconquered the whole Nile valley, but was not able to maintain his supremacy against the troops of Asshur-bani-pal, and retreated beyond the cataracts. The insurrection that broke out soon after in the Delta gave Tahraka another opportunity to descend the Nile, and he drove out the Assyrians. Necho, the general of Asshur-bani-pal, regained the Delta, and Rot-Amen, son-in-law of Tahraka, succeeded only to the thrones of Thebes and Napata. He put to death Necho, whom he had taken captive in a battle for the possession of the Delta, but was finally driven back to his Ethiopian states by Asshur-bani-pal, who came in person to reconquer Lower Egypt. Rot-Amen died without direct heirs, and Amen-meri-Nut, who was probably only distantly related to him, was proclaimed king.

He entered Egypt with a large army, and claimed the sovereignty. He was gladly received at Thebes, but the chiefs of the Delta united against him, and a bloody battle was fought before he entered Memphis. Amen-meri-Nut does not seem to have cared greatly for the crown of Egypt, for after receiving an immense tribute from the princes of the Delta, he withdrew to his country. The Ethiopian kings continued in possession of the Thebaid during the time of the dodecarchy in Lower Egypt. Amen-iritis, the queen whom Piankhi II., the successor of Amen-meri-Nut, had married to legitimate his occupancy of the Ethiopian throne, seems to have been a woman of superior merit, and, being charged with the regency of Egypt under three successive Ethiopian kings, rendered herself very popular in the Thebaid. Her daughter Shap-en-ep became the wife of Psammetik I. (Psammetichus, 664-610), who in alliance with the Greeks had dethroned the 11 kings his colleagues, and ruled over Lower Egypt. The favors which this king bestowed on foreigners offended the military class, and they emigrated in a body of 200,000 men to Ethiopia, where they formed a separate colony. The Ethiopians soon after had to resist an invasion by Psammetik II. (Psammis, 594-588), the successor of Necho II., who had married his own aunt, Net-aker, daughter of Shap-en-ep, in order to create a right to the Ethiopian sovereignty. After the conquest of Egypt by Cambyses in 525, the Ethiopians were also threatened with being absorbed in the great Persian empire. A numerous force, led by Cambyses, marched toward their frontier, but had to return; for leaving the banks of the Nile, and attempting to cross the Nubian desert, the army nearly perished with famine. The Ethiopians were left unmolested by Darius (521-486), who was satisfied with receiving from them a very small tribute. They sent to Persia every third year 4 pints of gold dust, 200 logs of ebony, 5 negro slaves, and 20 tusks of ivory. When Egypt was ruled by the Ptolemies, the arts and enterprise of the Greeks also entered Ethiopia, and led to the overthrow of the tyranny of the priests, and to the founding of Hellenic trading posts on the coast of the Red sea. Ptolemy Euergetes (247-222) conquered the southern country, and set up a throne of white marble with an inscription of his conquests. The Ethiopians soon regained their independence. During the reign of Augustus they advanced under their queen Candace as far as the Roman garrisons at Philæ, where Petronius, the legate of the prefect of Egypt, Ælius Gallus, repulsed them and pursued them to the neighborhood of Napata. But it appears that the Romans did not enter into possession of any part of Ethiopia, and that Augustus remitted the tribute. The influx of Arabs must have been very great, for at this period the population of Ethiopia is frequently spoken of as Arabian. For the history of the country

during our era, see *ABYSSINIA*.—The monuments of Ethiopia are in part of a decidedly Egyptian character. Many temples have been found wholly or partly hewn in the rocks of the mountains. Tombs are not frequent. Near Mount Barkal are the remains of several pyramids, which differ from the Egyptian in being much higher proportionally to the base. Higher up the river the monuments are wholly Ethiopian in style, and indicate the great wealth and culture of the ancient nation. Lepsius gives a detailed description of them. He found in all 30 names of kings and queens, and it appears that the kings were at the same time high priests of Ammon. The eldest son seems to have inherited the throne, unless the wife of the king should survive, in which case the succession fell to her. The crown prince during the lifetime of his father was a second high priest of Ammon. The worship of Ammon and Osiris was carried, according to Herodotus, from Meroë to Egypt, and the temple of Karnak and several Nubian monuments seem to commemorate this migration. The constant intercourse of the Ethiopians with the Egyptians renders it probable that the two nations had many points of agreement in manners and customs. (See *EGYPT*.)

**ETHIOPIA, Languages and Literature of.** The inscriptions on the pyramids in Ethiopia consist in part of hieroglyphs strongly resembling the Egyptian; but the language of the two countries was not the same. The Ethiopians used the hieroglyphs as a sort of sacred character, but without a complete knowledge of their use, and evidently rather as an ornament than as a means of conveying information. There is at least no doubt that at the time of the erection of the oldest pyramids a demotic graphic system was commonly in use among them. The prominent position which this style of writing occupies on the monuments, while the hieroglyphs seem to furnish at best only marginal notes, shows clearly that it must have been the current language of the country. It resembles the Egyptian demotic, but the constant repetition of the same signs leads to the supposition that it had a more limited alphabet, perhaps not exceeding 30 signs. The analogy of the history of the development of the Ethiopic and the Egyptian graphic systems extends still further. At a later period an Ethiopic-Greek style of writing came into use, which may be compared to the Coptic, and from which it borrowed several letters. (See *EGYPT, LANGUAGE AND LITERATURE OF*.) The Ethiopic-Greek is found in the inscriptions of Soba and in many others, especially on the walls of the temple in Wady es-Safra. These and the Ethiopic demotic inscriptions contain undoubtedly the true language of ancient Ethiopia; but its vocabulary and grammar have not yet been determined.—The language now designated as Ethiopic was spoken in the subsequent Abyssinian empire. It was originally one of the many dialects of the Arabic-African



branch of the Semitic stem. Tigré, with its capital Axum, was probably the first seat of it, and it spread thence with the formation of the Abyssinian empire over a larger territory, and became the chief language of the country. When the S. W. provinces gained the ascendancy and the seat of government was transferred to them, the Amharic dialect, which was in general use in that region, rose to the rank of a court language. The Ethiopic remained, however, for nearly three centuries more the literary and business language of the empire. The invasion of the Galla tribes and the subsequent division of the country, as well as the introduction of Mohammedanism, led gradually to its extinction. The Ethiopic church continued to study and use it as a sort of sacred language; but there are probably very few among the priests who are still conversant with it. The Amharic is now the most widely spoken dialect in the regions of ancient Ethiopia. It is used, though with variations, in Shoa and the district between the Tacazze and the Abai. The Tigré has preserved a greater resemblance to the Ethiopic, or the language of the former Abyssinian empire.—The name Ethiopic is derived from the classic appellation of this country, and passed over from the Greeks to the Abyssinians themselves. They called their country አጥጋጃጃ, Aithiopya, and their language Lesan Aithiopya. But the original native name of the people and their language is ገዕዝ, Geez, signifying emigration, and in a secondary sense emigrants, or the free. In origin and character the Ethiopic or Geez is a pure Semitic language. It was carried by emigrants from Yemen to Abyssinia, and with the exception of a few names of plants and animals, which it incorporated from the dialects current in the new country, and of a few commercial terms learned from Greek traders, it was kept free from foreign admixture. Its relation to Arabic is attested by the final short vowels in the construction of words, the large number of roots of three and four syllables, the internal formation of the plural, the construction of the subjunctive from the imperfect, and by many other characteristics not found in the North Semitic tongues. In other respects the difference is too great to warrant us in classifying the Ethiopic as a dialect of the Arabic. It is safe to infer that the Ethiopic developed for a time, after its separation from the North Semitic stem, somewhat in the direction of the Arabic, and then returned to the principles of the parent tongue. For this reason many old Semitic forms lost in Arabic are found again in Ethiopic. This strange mixture of the old and the new leads to the conclusion that the language passed through a history of at least 1,000 years before it attained to the type presented by the texts that have come down to us.—The Ethiopic system of writing differs in form and character from all known Semitic languages. It resembles the Himyaritic, and represents with it the southern branch

of graphic systems into which the prototype of the Semitic writing was early divided. It was originally written with consonants only, and from right to left; but the Abyssinians learned very early to write in the opposite direction, and to indicate vowel sounds by the addition of rings and strokes. The vowel signs came into use as early as the 5th century of our era; they are superior to the methods of indicating vowels employed by other Semitic tongues. Each of the 26 consonants that compose the Ethiopic alphabet has seven distinct forms. The simple consonant is uttered with the sound of *ā*, and its variants indicate the vowels *ū* (pronounced like *oo* in boot), *ī*, *ē* (sounded as in father), *ō*, and *ē*. The last named variant is often equivalent to the simple consonant without vowel sound. Four consonants, *g*, *kh* aspirate, *k*, and *g*, received occasionally from the Abyssinians a peculiar pronunciation not indicated by the ordinary forms, introducing the sound of *u* between these consonants and *a*, *e*, and *i*. These utterances were indicated by five special vowel signs. The later Ethiopic used also the sign of *uā* with the value of *va* in connection with other consonants. In the following table of the Abyssinian characters the modifications for vowel sounds are shown in the six extra forms of the letter *ha*:

ሀ	ha	ኀ	na	ሀ	za	ሀ	hu
ለ	la	ላ	ā	ረ	fa	ሂ	hi
ሐ	hha	ከ	ka	ፕ	psa	ሃ	há
ዎ	ma	ዐ	wa	ሄ	a	ሀ	he
ሠ	sa	ሀ	za	ሀ	a	ሀ	h, he
ረ	ra	ዎ	ja	ሀ	u	ሀ	ho
ሸ	sa	ዎ	da	ሂ	i	ቆ	qua
ቆ	ka	ገ	ga	ዓ	ā	ኀ	khua
ባ	ba	ጠ	ta	ዓ	e	ብ	kua
ፕ	tha	ሀ	pa	ሀ	e	ገ	gua
ኀ	cha	ሀ	tza	ሀ	o		

The Abyssinians separated words by ፡, sentences by ::, paragraphs by ❖ or == ::, and sometimes also by beginning a new line. They borrowed the signs of numbers from the Greeks, introducing slight variations to assimilate them with their own graphic system. The Ethiopic, like most Semitic languages, constructed numerous words out of simple verbal roots, by adding particles, doubling one or more consonants, or changing the vowel sound. Such words formed again the stem of many other derivatives. Time was considered as either complete or incomplete, and accordingly only two tenses are distinguished, the perfect and the imperfect. The latter embraced the present and the future, and inasmuch as that which is thought and willed and that which could be, should be, or would be, fall within these con-

ceptions, the imperfect is also the source of the moods. There are only two, the subjunctive and the imperative. Persons, gender, and number are indicated by pronominal prefixes to a verb in the imperfect tense or in the subjunctive mood, but by suffixes when the verb is in the perfect tense. The prefixes and suffixes used in conjugating verbs are abbreviations of the personal pronouns. Only the masculine and feminine genders are distinguished. The masculine has no special termination. Feminine words end generally in *ót*, which was the original form, or in abbreviations and assimilations of this termination, as *at*, *et*, and *t*. The Ethiopic, like the Syriac, abandoned the dual number. The singular and plural numbers are strictly contrasted; even the collectives are capable of receiving a plural termination, and the external formation of the plural is often substituted by an internal change of vowel. These plural forms, thus internally constructed, admit of a further plural termination, generally feminine. The cases of nouns, as in other Semitic languages, are not fully indicated, only the nominative, genitive, and accusative being recognized. The pronouns comprise demonstratives, reflexives, interrogatives, and personals. The prepositions are frequently appended to pronominal suffixes, and conjunctions are often derived from prepositions, if not from relative or demonstrative pronouns, and are sometimes used as enclitics. The Ethiopic has no article, like all Abyssinian languages with the exception of the Saho. Where in other languages it would be necessary to use an article in order to convey a certain idea, the Ethiopic makes use of relative or demonstrative pronouns. Almost every part of a sentence is subordinate to the verb, even the subject, which is often put in the accusative or is governed by prepositions. Subject and predicate stand side by side without a copulative, and agree in gender and number. The position of the parts of speech in a sentence is not governed by strict rules. The predicate stands generally first, next the subject, and last the object.—The literature of the Ethiopic or Geez is chiefly confined to the service of the church. There are numerous translations of the books of the Old and New Testaments and of foreign theological works. There are also some original theological disquisitions, which bear an unmistakable impress of the phraseology of the Bible. Such independent works date principally between A. D. 1300 and 1600. Books on conjuring, magic, astrology, and medicine were also introduced during this period. Early Ethiopic poetry bears a strong resemblance to the Hebrew psalms, but it fell gradually from Biblical subjects to eulogies of saints, and decreased at the same time in literary worth. There is little of metric construction, and at best only an attempt at harmonizing the verses, but without understanding the principles of rhyme. No native grammar has come down to us; the attempts at Amharic-Ethiopic lex-

icons that have been preserved are all in a very crude condition and without grammatical references.—The European study of the Ethiopic dates from the 16th century. In 1548 Tessa-Zion, an Abyssinian, published a New Testament in Rome; but contemporaneous with him, if not earlier, were Johann Potken, Marianus Victorius, Scaliger, Petræus, Nisselius, Wemmers, and Castellius. Hiob Ludolf is the father of the more accurate knowledge of the language. He published in the latter half of the 17th century a grammar and a lexicon, which are still the standard authority. His works are based on oral instruction received from an Abyssinian, at a time when the Ethiopic was still somewhat in use and a common study. But philological science has made such progress that his labors need remodelling. The Ethiopic languages were subsequently neglected. For 150 years scarcely a text was revised or republished, and only a few Hebrew grammars made an occasional reference to them. In 1823 Hupfeld published *Exercitationes Æthiopicae*, giving a new impulse to Ethiopian philology. The principal later works are: F. Tuch, *Commentatio de Æthiopicæ Linguae, Sonorum Sibilantium, Natura et Usu* (Leipsic, 1854); A. Dillmann, *Grammatik der Aethiopischen Sprache* (Leipsic, 1857); Eberhard Schrader, *De Lingua Æthiopicæ cum Cognatis Linguis Comparatione* (Göttingen, 1860).—The Amharic language (properly Amhariffña) succeeded the Ethiopic or Geez, of which it is a modification, and enters extensively into the languages of Argobba and Harrar. Amhara, formerly an important province of Abyssinia, is now the seat of several Galla tribes. As a descendant of the Ethiopic, the Amharic is also related to the Semitic; but it has adopted many forms and words from surrounding nations which bear no relation to that family. It is written with the same alphabet as the Ethiopic, with the addition of seven peculiar orders of letters. Its grammatical forms and construction are also very similar to those of the parent tongue, though the verb admits of a greater variety of flexion. It has seven moods: indicative, contingent, subjunctive, constructive, imperative, infinitive, and participial. The simple preterite of the indicative, the compound preterite of the contingent, and the compound preterite of the constructive, are used to express past time. The present indicative, the second or aorist constructive, and the contingent with conjunctions denote the present. The infinitive can be used as a verbal noun, and as such it assumes nominal suffixes, but relates to or acts upon other nouns in a verbal capacity. By the aid of suffixed pronouns and prepositions, the verb is capable of expressing a whole sentence by itself. The verb is generally at the end of the sentence, whether the object be simple or complex. The language is very rich in words, but it has no literature. The earliest work on the Amharic language is Ludolf's *Lexicon Amharico-Latinum* (Frank-

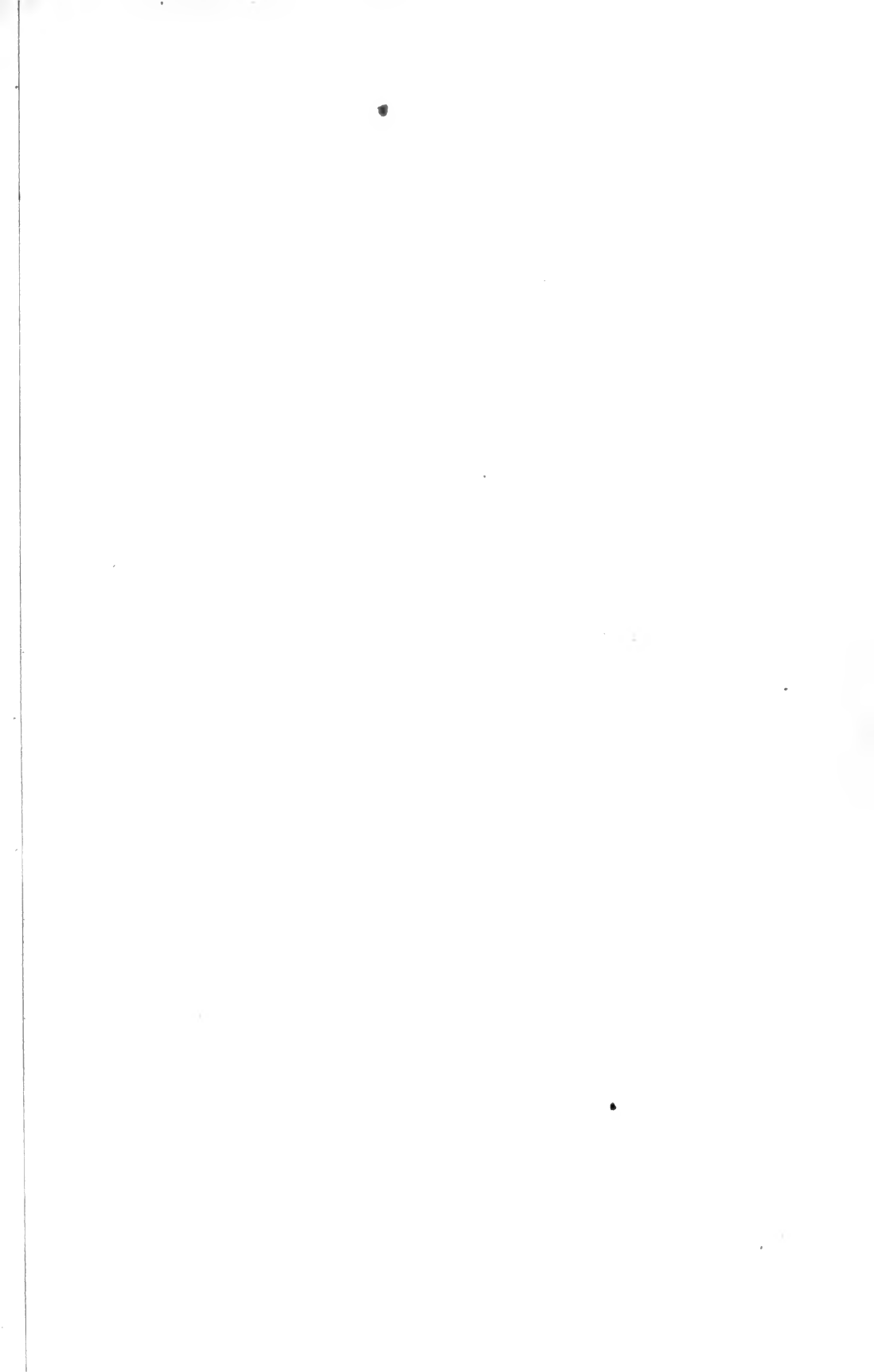

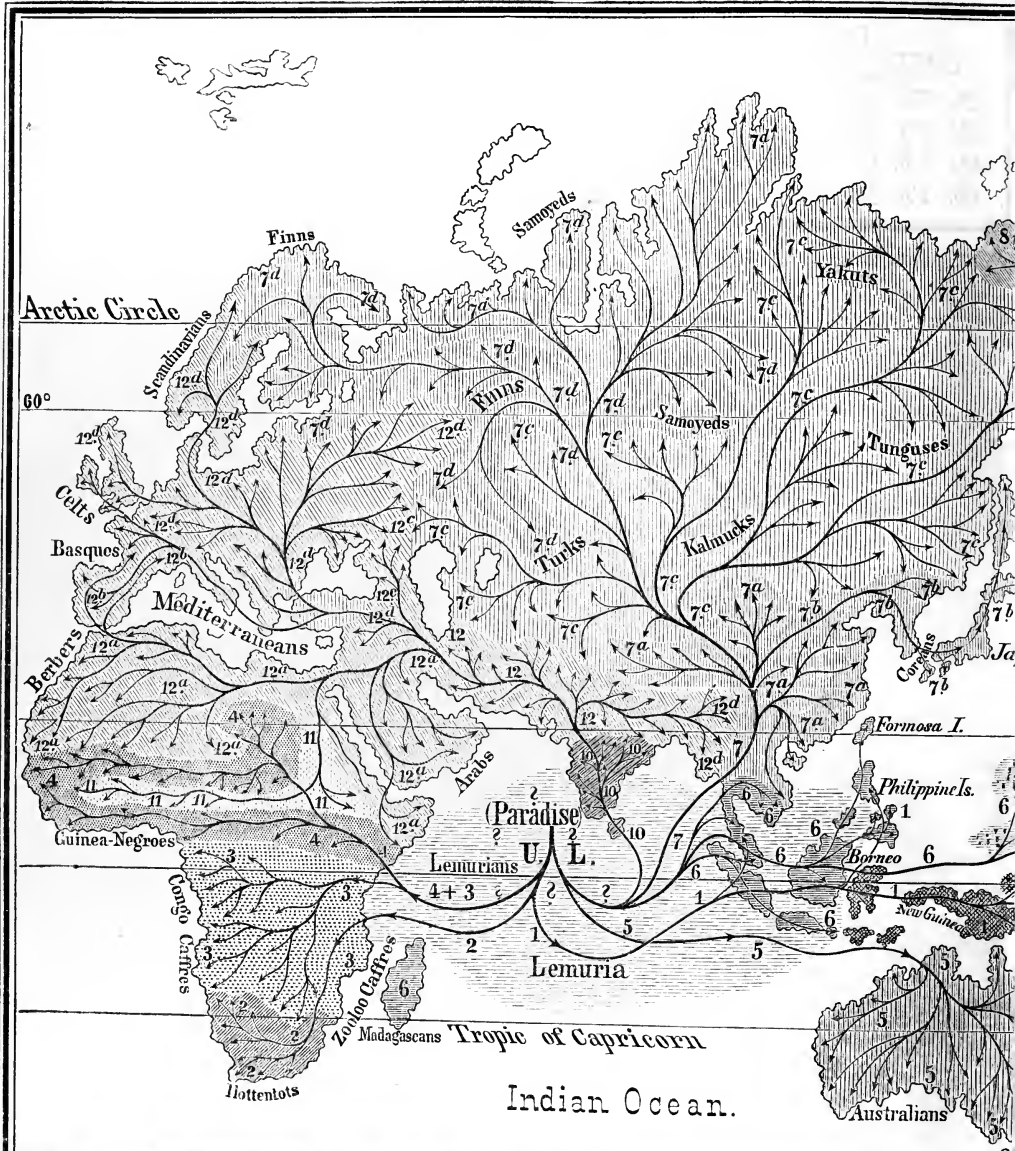

12 Mediterraneans	10 Drayidas	8 Arctics	6 Malays	4 Negrees	2 Hottentots
11 Nubians	9 Americans	7 Mongolians	5 Australians	3 Caffres	1 Papuan

THE DOMINANT RACES OF MEN.

1. MEDITERRANEANS:

- 1a The Semites.
- 1b The Basques.
- 1c The Caucasians.
- 1d The Indo Germans.

2. MONGOLIANS:-

- 7a The Indo-Chinese.
- 7b The Coreo-Japanese.
- 7c The Altaians.
- 7d The Uralians.

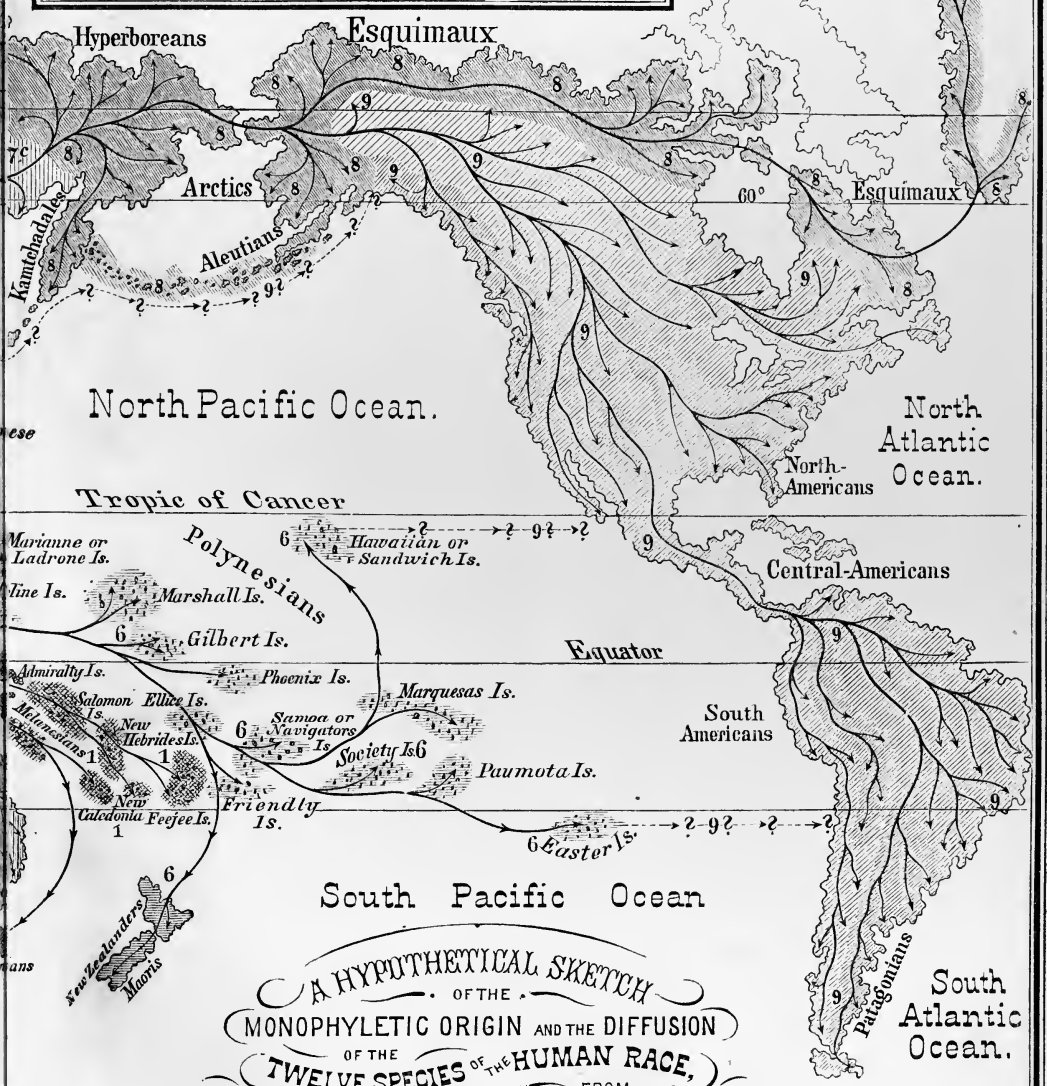

A HYPOTHETICAL SKETCH  
 OF THE  
 MONOPHYLETIC ORIGIN AND THE DIFFUSION  
 OF THE  
 TWELVE SPECIES OF THE HUMAN RACE,  
 FROM  
 LEMURIA OVER THE EARTH.



fort, 1698). The Amharic translation of the whole Bible, executed in Egypt by an Abyssinian monk, Abu Rumi or Ruhn, a native of Gojam, which was revised and published by the British and foreign Bible society (London, 1841), furnishes more valuable material for the study. Isenberg's "Dictionary, Amharic and English, and English and Amharic" (London, 1841), "Grammar of the Amharic Language" (1842), "Amharic Spelling Book," "Amharic Catechism," "Amharic Geography," "History of the Kingdom of God in Amharic," "Universal History in Amharic," and "Book of Common Prayer in Amharic," constitute the principal publications in the language.—Among the other languages related to Ethiopic, none stands as near as the dialect of Tigré. Around it are grouped the Adari, the Affar, the Somauli, and the Saho dialects, and the languages of the Danakils and the Adaiel, and of the district of Harrar. The circle of the languages akin to the Ethiopic is constantly increasing, and indicates an extensive emigration of the Semitic races across the Red sea. These dialects are unimportant. They have no graphic system, and, like all unwritten languages, have undergone numerous changes. The variety of Ethiopic or Abyssinian dialects is perhaps unparalleled.—The best authorities on the languages spoken in the regions of ancient Ethiopia, and of the Ethiopic language in particular, are D'Abbadie, Biot, Dillmann, Franz, Gesenius, De Gobineau, Letronne, Lepsius, Renan, Rigby, Rödiger, Salt, and Schrader. See also König, *Vocabulaires appartenant à diverses contrées ou tribus de l'Afrique*, in vol. iv. of *Recueil de voyages*, published by the société de géographie. Other vocabularies of Ethiopic languages will be found in Salt's "Voyage to Abyssinia" (London, 1814), and in Dr. G. Schweinfurth's *Linguistische Ergebnisse* (Berlin, 1873).

**ETHNOLOGY** (Gr. *ἔθνος*, nation, and *λόγος*, discourse), the science which treats of man as a member of a tribe or nation, and of his culture, morals, and language. It is closely allied to anthropology, which treats of man zoologically, and of his physical condition and inherent faculties. Ethnology and ethnography are sometimes used indiscriminately, but the former term is more usual. The terms linguistic and descriptive ethnology have recently been introduced to designate the two main branches of ethnological research. The separation of anthropology from ethnology has also been made recently; but in this article they will be considered together. It was formerly required that an ethnologist should not only be a naturalist, but should be familiar with philology or the science of language, archæology or the study of human monuments and remains, and physical geography as far as it relates to climatic and kindred influences on the races. From the difficulties inherent in the subject, the science of ethnology long remained in a very unsatisfactory condition.

Now, however, it is considered an entirely distinct science, and anatomy, comparative anatomy, mental and moral philosophy, physiology, psychology, philology, climatology, archæology, and kindred studies form separate divisions of scientific research. Ethnologists and anthropologists confine themselves now to systematizing the results obtained in all and each of these sciences; the latter striving to establish the relation existing between the various types of man for a classification of the human species into races; the former trying to analyze the natural and artificial forms of man in his social relations, in order to detect the forces which cause divergences and analogies among them, and to build thereon a classification of the human race into tribes and nations.—The ancient writers contributed very little to ethnology. Among the Greeks, Herodotus and Xenophon give a faint idea of the ancient populations; among the Latins, Sallust, Cæsar, and especially Tacitus, supply fuller information; yet it is only in comparatively modern times, since the discovery of America, the circumnavigation of the globe, the explorations of Asia, Africa, and the Pacific islands, and the revival of physical and physiological studies, that ethnology can be said to have begun to accumulate the materials necessary for a natural classification of the human races. The most important of the classifications proposed during the last two centuries are the following, most of which, it will be observed, are purely anthropological. Linnæus, in the first edition of his *Systema Naturæ*, makes four divisions of the genus *homo*, founded upon the color of the skin, viz.: 1, European, whitish; 2, American, coppery; 3, Asiatic, tawny; and 4, African, black. The divisions proposed by Buffon were five: the Hyperborean (including the inhabitants of the polar regions and of eastern and central Asia, or Laplanders and Tartars), Southern Asiatic, European, Ethiopian, and American. Blumenbach adopted these, changing the names of some of the divisions, and more accurately defining their geographical distribution. He divided mankind into the five classes of Caucasian, Mongolian, Ethiopian, American, and Malay, founded on the combined characters of the complexion, hair, and skull. Before Blumenbach, Camper, a Dutch anatomist, attempted to classify the races by the shape of the skull and the size of the facial angle. Cuvier compares the areas of the cranium and face sawed vertically on the median line from before backward; according to this measurement, the area of the former in the highest races is four times that of the face, in the negro the area of the face being one fifth larger. The *norma verticalis* of Blumenbach measures the breadth of the skull and the projection of the face, and consists in viewing skulls from behind and above, the eye being fixed on the vertex of each. The comparisons of skulls made by Dr. Morton in his ethnological works are based on

the cubic contents of each cranium, measured by noting the quantity which they will hold of any small granular substance. Cuvier divides mankind into three stocks: 1, Caucasian, with the branches Armenian, Indian, and Seythian or Tartar; 2, Mongol or Altaic, with the branches Calmucks, Kalkas, Mantchoos, Japanese, and Siberians; 3, Negro or Ethiopian. He adopts the ill-chosen term "Caucasian" from Blumenbach. It originated from the prevalent belief at that time that the white races had their cradle in the mountains of Caucasus; as there is no foundation for such a belief, the name has been given up by many modern writers. Fischer, in his *Synopsis Mammalium*, divides man into *homo Japeticus*, with the branches *Caucasicus*, *Arabicus*, and *Indicus*; *H. Neptunianus*, with the branches *Occidentalis* and *Papuensis* (the Malay race); *H. Scythicus* (Calmucks and Mongols), with the branches *Sinicus* and *Hyperboreus*; *H. Americanus* (South American indigenes), with the branch *Patagonus*; *H. Columbicus*, the indigenes of North America, eastern Mexico, the Antilles, &c.; *H. Ethiopicus*, with the branches *Caffer*, *Melanoides* (Papuans, Feejeeans, &c.), and *Hottentottus*; and *H. Polynesiensis*, the Alfooroos, Australians, &c. Lesson, in his *Mammalogie*, divides the races, according to complexion, into the white or Caucasian, the yellow or Mongol, and the black or negro stocks. His later arrangement in his *Spécies des mammifères* is the following: 1, the white race; 2, the bistre black or dusky race, including Hindoos, Caffres, Papuans, and Australians; 3, the orange-colored or Malay race; 4, the yellow race, including the Mongolians and Oceanic and South American branches; 5, the red, the North American and Carib races; 6, the black race, including the African and Asiatic negroes, Nigritians, Tasmanians, Hottentots, and Bushmen. The divisions of Duméril are: the Caucasian or Arab-European, Hyperborean, Mongolian, American, Malay, and Ethiopian. Virey makes two species of the genus *homo*: the first with a facial angle of 85° to 90°, including the white Caucasian race, the yellow Mongolian, and the copper-colored American; the second with a facial angle of 75° to 82°, including the dark brown Malay, the black or negro race, and the blackish Hottentots and Papuans. The sections of Desmoulins are: Celto-Scyth- Arabs, Mongols, Ethiopians, Euro-Africans, Austro-Africans, Malays or Oceanians, Papous, negro Oceanians, Australasians, Columbians, and Americans. Bory de Saint-Vincent amplifies considerably the divisions of Desmoulins, making 15 stocks in three classes, as follows: I. Races with smooth straight hair, peculiar to the old world, including: 1, the Japetic stock (named from Japetus, whom the ancients regarded as the progenitor of the race inhabiting the West, *audax Japeti genus*, the original seat of which is the mountain chains nearly parallel to lat. 45° N.), the Caucasian, Pe-

lasgic, Celtic, Slavic, and Germanic races; 2, the Arabian stock, including the ancient Egyptians, North Africans, and Adamic or Syrian races; 3, the Hindoo stock; 4, the Scythic stock, or Tartars; 5, the Chinese stock; 6, the Hyperborean stock (Laplanders, &c.); 7, the Neptunian stock, including the Malays and Oceanic and Papuan races; 8, the Australasian stock. II. Races of the new world, with straight hair, including: 9, the Columbian stock, the North American races; 10, the American stock, the South American races; 11, the Patagonian stock. III. Crisp-haired or negro races, including: 12, the Ethiopian stock, or black races of central Africa; 13, the Caffre stock; 14, the Melanian stock, or races of Madagascar, Papua, Feejee islands, Tasmania, &c.; and 15, the Hottentot stock. Kant divides man into four varieties, white, black, copper, and olive, corresponding to the Caucasian, Negro, American, and Mongolian. Dr. Prichard, in his "Researches into the Physical History of Mankind" (1826-'47), refers mankind to seven stocks or classes of nations, the principal mark of distinction being the peculiar form of the skull; these are: 1, the Iranian (the Caucasian of previous writers), in the form of the skull and in physical traits resembling Europeans, including some Asiatic and African nations; 2, the Turanian or Mongolian; 3, the American, including the Esquimaux and kindred nations; 4, the Hottentot and Bushman; 5, the Negro; 6, the Papuan or woolly-haired Polynesians; and 7, the Australian and Alfooroo nations. Taking the color of the hair as a principal character, Prichard makes three great varieties: 1, the melanic, with very dark or black hair; 2, the xanthous, with yellow, red, or light brown hair, blue or light eyes, and fair skin; and 3, the leucous, or albinos, with white or pale yellow hair, very soft, fair, and delicate skin, and a red hue to the choroid of the eye. According to this author, examples of these varieties are found in all the races. Martin, in his "Natural History of Man and Monkeys" (1841), divides the human race into the following five stocks: 1, the Japetic, including the European branch, or the Celtic, Pelasgic, Teutonic, and Slavic nations; the Asiatic branch, or the Tartaric, Caucasie, Semitic, and Sanskrit nations; and the African branch, or the Mizraimic nations (ancient Egyptians, Ethiopians, Abyssinians, Berbers, and Guanches); 2, the Neptunian, including the Malays and Polynesians; 3, the Mongol, including also the Hyperborean; 4, the prognathous (a term adopted from Prichard), including the Negro, Hottentot, Papuan, and Alfooroo branches; 5, the occidental, including the indigenes of North and South America. Dr. Latham, in his "Natural History of the Varieties of Man" (1850), separates the human family into three primary divisions, the *Mongolidæ*, *Atlantidæ*, and *Japetidæ*. The *Mongolidæ* inhabit Asia, Polynesia, and America, and are subdivided into: *a*, Altaic *Mongolidæ*, including the Seri-



form (Chinese, &c.) and Turanian (Mongol) stocks; *b*, Dioscurian Mongolidæ (the Caucasian races of earlier writers); *c*, oceanic Mongolidæ, including Malays, Polynesians, Papuans, and Australians; *d*, hyperborean Mongolidæ, Samoyeds and similar nations; *e*, peninsular Mongolidæ, Coreans, Japanese, and the nations of the islands and peninsulas of N. E. Asia; *f*, American Mongolidæ, the Esquimaux and American Indians; *g*, Indian Mongolidæ, in Hindostan, Cashmere, Ceylon, &c. The Atlantidæ inhabit Africa and S. W. Asia, and are subdivided into: *a*, negro Atlantidæ, occupying the central negro area of the continent; *b*, the Caffre Atlantidæ; *c*, the Hottentot Atlantidæ; *d*, the Nilotic Atlantidæ; *e*, the Amazirgh Atlantidæ, or Berbers; *f*, the Egyptian Atlantidæ; *g*, the Semitic Atlantidæ, or Copts, Abyssinians, Arabians, Syrians, Hebrews, &c. The Japetidæ inhabit Europe, and embrace: *a*, the occidental Japetidæ, the Celts and their branches; *b*, the Indo-Germanic Japetidæ, the European and Iranian Indo-Germans. Dr. Pickering, in the "Races of Man, and their Geographical Distribution" (1848), enumerates eleven races, divided into four groups, according to complexion, as follows: *a*. White, including: 1, Arabian, with nose prominent, lips thin, beard abundant, and hair straight and flowing; 2, Abyssinian, with complexion hardly becoming florid, nose prominent, and hair crisped. *b*. Brown, including: 3, Mongolian, beardless, with perfectly straight and very long hair; 4, Hottentot, with negro features, close woolly hair, and diminutive stature; 5, Malay, with features not prominent in profile, darker complexion, and straight and flowing hair. *c*. Blackish brown, including: 6, Papuan, with features as in 5, abundant beard, harsh skin, and crisped or frizzled hair; 7, Negrillo, apparently beardless, with diminutive stature, negro features, and woolly hair; 8, Indian or Telingan, with Arabian features, and straight and flowing hair; 9, Ethiopian, with features intermediate between the last and the negro, and crisped hair. *d*. Black, including: 10, Australian, with negro features, but straight or flowing hair; and 11, Negro, with close woolly hair, flattened nose, and very thick lips. Prof. Agassiz, in the "Types of Mankind," by Messrs. Nott and Gliddon (1854), asserts "that what are called human races, down to their specialization as nations, are distinct primordial forms of the types of man." He makes the following realms: I. Arctic, inhabited by Hyperboreans; II. Asiatic, by Mongols; III. European, by white men; IV. American, by American Indians; V. African, by Nubians, Abyssinians, Foolahs, Negroes, Hottentots, and Bushmen; VI. East Indian or Malayan, by Telingans, Malays, and Negrillos; VII. Australian, by Papuans and Australians; and VIII. Polynesian, by South sea islanders. In a subsequent work ("Indigenous Races of the Earth," 1857) Nott and Gliddon give an ethnographic tableau in which the races are divided

zoölogically according to the eight realms of Prof. Agassiz; they are also grouped physiologically (after Desmoulins, Achille Comte, and O. d'Halley) into 65 families. The same realms have also their corresponding classes arranged linguistically, after Maury, Crawford, Logan, &c., as follows: realm 1, with the Finno-Ugrian, containing 6 groups; realm 2, with the Tartarian, Sinic, North and South Dravidian, containing 5, 6, 4, and 6 groups respectively; realm 3, with the Ugrian, Iberian, Indo-Germanic or Japetic, Semitic, and Hamitic, containing respectively 3, 1, 6, 9, and 4 groups; realm 4, with the northern, central, and southern, containing 6, 4, and 4 groups; realm 5, with the Atlantic, Mandingo, upper Guinean, upper Soodanian, delta of the Niger, basin of the Tchad, central Africa, Senegambian, Guinean, Congo, Madagascar, and Hottentot, containing 4, 9, 3, 4, 3, 1, 2, 4, 3, 8, 1, and 3 groups; realm 6, with the polyglot class, containing 13 groups; realm 7, with the polyglot class, containing 2 groups; and realm 8, with the monoglot and polyglot classes, containing 4 and a single group.—Among the difficulties encountered in ethnology, the first is the important question of the descent of man. Huxley, Wallace, Darwin, Haeckel, and many others have advocated the hypothesis that man is a descendant of an ape-like animal. It is, however, acknowledged that no one of the now living genera of apes was the immediate ancestor of man. The orang has the closest resemblance to man in the convolutions of the brain; the chimpanzee, in the form of the skull; the gorilla, in the development of the hands and feet; and the gibbon, in the construction of the chest. On a voyage around the world with the recent Austrian scientific expedition (1868) Scherzer and Schwarz took numerous careful measurements of the bodies of individuals belonging to different races, and the conclusion arrived at, as given by Weissbach, was that the resemblance between man and apes is not restricted to any particular people, but is traceable in some portion of the body in all nations; that an heirloom of the relationship is owned by every one, and that even Europeans cannot claim exemption from it. (See EVOLUTION.) The question of the unity or diversity of origin of the different races can also be answered only hypothetically. Many believe still in the blood relationship of all human beings, while others are of opinion that each race originated independently. Not all who accept the doctrine of evolution are monogenists; and the polygenists, or those who believe in the plurality of origin of the human race, base their belief on the fact that the languages do not seem to have come from one and the same source. In order to overcome this evidence, it is necessary to accept the doctrine that primitive man was speechless. (See LANGUAGE.) The difficulties in the way of classifying the numerous races or types of man are as great as in the case of animals and plants.

All varieties are connected by numberless forms of transition, and it is impossible to settle beyond all dispute what is genus, and what species; what race, and what variety. Blumenbach's classification, given above, dividing mankind into five races, has been abandoned, because the difference between them is too great. Queinstedt remarks: "If negroes and Caucasians were snails instead of human beings, all zoölogists would agree in classifying them as two different species." The races are generally distinguished either according to the character of the hair, the color of the skin, the form of the skull, or the convolutions of the brain. The latest results arrived at through the measurements and weighings of the brain will be found in the works of Fritsch, Hitzig, and Meynert. It is believed that in the development of the brain, especially of the frontal lobe, may be retraced the history of man, and that skulls of primitive man furnish a clue to the intellectual spirit of primitive ages. This subject is fully treated in Schaafhausen's *Ueber die Urform des menschlichen Schädels* (Bonn,

1868). The form of the skulls of the first inhabitants of Europe is ably discussed by Virchow, in his work *Die altnordischen Schädel zu Kopenhagen* (1871). Mankind is divided after the shape of the skull into long-headed (*dolicocephali*) and short-headed (*brachycephali*); the negroes and Australians are the strongest types of the former, and the Mongolians of the latter. Between these two extremes are placed the medium-headed (*mesocephali*), as the Americans. In each of these three divisions are further distinguished the *prognathi*, or those having oblique teeth on account of the projection of the jaws; and the *orthognathi*, or those having straight teeth because their jaws project but little. It seems, however, that the labors of the last ten years in measuring and investigating the forms of skulls have not been sufficiently rewarded. A more satisfactory classification is obtained from the character of the hair of the head, which seems to be strictly preserved in each race. The classification made on this basis, combined with the latest results of linguistic research, is given as follows:

CHARACTER OF HAIR.	Species.	Race.	Habitat.	Came from the	Present number in millions.	Origin of language	State of development.
ULOTRICHES (woolly). LOPHOCOMI (in tufts) ERIOCOMI (fleecey).	I. PAPAUNS. <i>Homo Papua.</i>	1. Negritos.....	Malacca, Philippines...	West.....	2	Single	Retrograde.
		2. Papuans.....	Papua.....	West.....			
		3. Melanese.....	Melanesia.....	Northwest.....			
	II. HOTTENTOTS. <i>Homo Hottentottus.</i>	4. Tasmanians.....	Tasmania.....	Northeast.....	3	Single	Retrograde.
		5. Hottentots.....	Capeland.....	Northeast.....			
		6. Bushmen.....	Capeland.....	Northeast.....			
	III. CAFFRES. <i>Homo Cafér.</i>	7. Zooloo Caffres.....	East South Africa.....	North.....	20	Single	Progressive.
		8. Bechuanas.....	Central South Africa.....	Northeast.....			
		9. Congo Caffres.....	West South Africa.....	East.....			
	IV. NEGROES. <i>Homo niger.</i>	10. Tibboo negroes.....	Tibboo.....	Southeast.....	130	Plural	Progressive.
		11. Soodan negroes.....	Soodan.....	East.....			
		12. Senegambians.....	Senegambia.....	East.....			
		13. Nigritions.....	Nigritia.....	East.....			
LISSOTRICHES (smooth). EUTHYCOMI (straight). EUFLOCOMI (curly).	V. AUSTRALIANS. <i>Homo australis.</i>	14. North Australians.....	North Australia.....	North.....	3	Single	Retrograde.
		15. South Australians.....	South Australia.....	West.....			
	VI. MALAYANS. <i>Homo Malayus.</i>	16. Sundanese.....	Sunda Archipelago.....	West.....	30	Single	Stationary.
		17. Polynesiens.....	Pacific Archipelago.....	West.....			
		18. Madagascans.....	Madagascar.....	East.....			
	VII. MONGOLIANS. <i>Homo Mongolus.</i>	19. Indo-Chinese.....	Thibet, China.....	South.....	550	Single?	Progressive.
		20. Coreo-Japanese.....	Corea, Japan.....	Southwest.....			
		21. Altaians.....	Central Asia, N <sup>th</sup> Asia.....	South.....			
		22. Uralians.....	N. W. Asia, N. Europe, Hungary.....	Southeast.....			
	VIII. ARCTICS. <i>Homo arcticus.</i>	23. Hyperboreans.....	N. N. E. Asia.....	Southwest.....	3	Plural?	Stationary.
		24. Esquimaux.....	N. N. E. America.....	West.....			
25. North Americans.....		North America.....	Northwest.....				
IX. AMERICANS. <i>Homo Americanus.</i>	26. Central Americans.....	Central America.....	North.....	12	Single?	Retrograde.	
	27. South Americans.....	South America.....	North.....				
	28. Patagonians.....	Patagonia.....	North.....				
X. DRAVIDAS. <i>Homo Dravida.</i>	29. Deccanese.....	India.....	East?.....	34	Single.	Stationary.	
	30. Singalese.....	Ceylon.....	North?.....				
XI. NUBIANS. <i>Homo Nuba.</i>	31. Shangallas.....	{ Nubia.....	East.....	10	Single?	Stationary.	
	32. Dongolese.....	{ Nubia.....	East.....				
XII. MEDITERRANEANS. <i>Homo Mediterraneus.</i>	33. Foolahs.....	Foolah.....	East.....	550	Plural.	Progressive.	
	34. Caucasians.....	Caucasus.....	Southeast.....				
	35. Basques.....	N. N. E. Spain.....	South?.....				
	36. Semites.....	Arabia, N <sup>th</sup> Africa, &c.....	East.....				
	37. Indo-Europeans.....	S. W. Asia, Europe, &c.....	Southeast.....				
	Half Breeds.....	Everywhere; principally America and Asia.....	.....				.....

—In order to gain a clear view of the geographical distribution of mankind, it is necessary to go back three or four centuries to the time of the discovery of America and of the Indian archipelago, when the present extensive mingling of species, and especially the

general invasion of the Indo-European races, were not so far advanced. In the following rapid survey of the human races copious references have been made to the latest works of travel. Our space does not permit us to give in detail the customs and morals of each;

we confine ourselves instead to a succinct enumeration of the physical characteristics, the languages, and the habitats. Beginning with the lowest types of man, we must consider first the Ulotriches or woolly-haired men, among whom the Papuans probably resemble very closely the primitive species. They inhabit at present the island of Papua and the Melanesian archipelago. A few are found in Malacca and on the Philippines. The recently extinct race of Tasmanians belonged also to this species. The Malays supplanted the Papuans in the S. E. portion of Asia, and drove them further east. The skin of the Papuans is black, with a slightly brown and occasionally blue tinge. The crisp hair grows in tufts, is wound spirally, and often more than a foot long, forming a tall woolly peruke. The forehead is narrow and flattened, the nose turned up and large, and the lips thick and broad. The Papuans differ greatly from their neighbors the Malays and Australians, for which reason they are generally classified now as a distinct species. Their dwellings resemble the lake dwellings recently discovered in central Europe. (See Semper, *Die Philippinen und ihre Bewohner*, Würzburg, 1868). The Hottentots are closely related to the Papuans, having like them hair in tufts. The females of both species are very fat around the loins. The skin of the Hottentots is yellowish brown; the face is exceedingly flat; the forehead and the nose are very small; the nostrils large; the mouth very broad, with thick lips; chin small and pointed. It is believed that the Hottentots occupied for some time the whole of S. E. Africa; they inhabit now only the most southern portion. The species is rapidly decreasing, and of the Hottentots proper only two tribes still exist, the Korana and the Namaqua. The Bushmen, who belong to the same species, live in the mountain regions of the interior of Capeland. The language is very peculiar, especially on account of the clicking. (See Schmarda, *Reise um die Erde*, 3 vols., Brunswick, 1861.) The Caffres have also crisp hair, not in tufts, but fleecy, and the skin runs through all tinges from yellow-brown to brown-black. They differ from the negroes in language and in the form of the skull. The face is thin and long, the forehead high and vaulted, the nose often aquiline, the chin pointed, and the lips are not very thick. The various languages of the Caffre races are retraced to the Bantu language, now dead, of the Hamitic group. This species inhabits equatorial Africa from lat. 20° S. to 4° N. The principal tribes are the Zooloo, Zambesi, Bechuanas or Sechuanas, Herreros, and Congos. They are said to have come from the northeast.—The genuine negro is now carefully distinguished from the Caffres, Hottentots, and Nubians. Only the tribes in the eastern portion of the Sahara, the Soodanese in the south of the great desert, and the population of the west African coast lands, from the Senegal in the north to below the mouth of

the Niger in the south, belong to this species. All the negro races seem to have come from the east. The color of the skin is more or less deep black; the skin itself is velvety, and generally emits a bad odor. The hair resembles that of the Caffres, but the face has a different shape. The forehead is exceedingly flat and low; the nose broad, thick, and little protruding; the lips are puffy and turned up very high; and the chin is very short. The genuine negro has always very thin calves and very long arms. This species separated probably very early into numerous tribes, inasmuch as the many totally different languages spoken by them cannot be retraced to the original tongue. The migrations of the African races so far noticed are due in part to the slavery practised among them, compelling the weaker tribes to move if possible beyond the reach of the stronger. They lived undoubtedly much further north at a very remote time; but the immigration of the Mediterraneans (Caucasians), and especially of the Hamites, across the isthmus of Suez, compelled them to cede their original habitation to the superior foreigners. Bearing in mind the age of the Egyptian empire, and the time previously needed for its establishment, it is considered probable that the Hamitic invasion took place about 6000 B. C. (See AFRICA, LANGUAGES OF; Barth's "Travels and Discoveries in North and Central Africa," 1855-'8; Bleek's "Grammar of South African Languages," London, 1869; Duveyrier, *Exploration du Sahara*, Paris, 1864 *et seq.*).—Among the eight species of the branch of smooth-haired men, the Australians or Australian negroes occupy the lowest rank, and seem to inhabit only the large island of Australia. They resemble the negroes in having a black or brown-black skin, a flat and retreating forehead, a thick nose, and puffy lips, and in the almost total want of calves. Their hair is either quite straight or somewhat curly. It is possible that they are related to the Dravidas. They are grouped into North and South Australians in accordance with the latest linguistic researches. (See AUSTRALIA; Christmann's *Australien, Geschichte der Entdeckungsreisen und der Kolonisation*, Leipsic, 1870.) The Malays are ethnologically of great importance, though not very numerous. High authorities consider it certain that the forefathers of the Malays, called Pro-Malays, were the ancestors of most of the nations of Asia, Europe, and America. The modern Malays comprise three races far distant from each other. The Sundanese inhabit Malacca, the Sunda archipelago, and the Philippines; a branch of them is found on the island of Madagascar, and another is scattered over the Polynesian archipelago. The Malays are very fond of navigation, which explains the great territorial extent of the species. Their early habitat was probably the S. E. portion of the Asiatic continent, whence they advanced toward the east and south, pushing the Papuans before them. They

are physically very similar to the Mongolians and Mediterraneans. The head is generally short, though sometimes of considerable length. The hair is smooth and straight, but occasionally curly. The skin is brown, but frequently with a yellow, and also with a ruddy tinge. The face is broad, the nose well developed, and the lips are thick; but the eyes are not quite as small and oblique as those of the Mongolians. Wallace measured several crania of the species so far noticed, and, as the following table shows, the difference between the Malays and Polynesians is not very great, while it is quite large among the others:

NUMBER OF CRANIA.	Capacity.	Proportion of width to length.	Proportion of height to length.
83 Malays (66 male) .....	60 to 91	·70 to ·92	·72 to ·90
28 Papuans (23 male) .....	66 to 80	·65 to ·85	·71 to ·85
136 Polynesians (90 male) .....	62 to 91	·69 to ·90	·68 to ·88
23 Australians (16 male) .....	53 to 86	·57 to ·80	·64 to ·80
72 Negroes (38 male) .....	66 to 87	·64 to ·83	·65 to ·81

(See Wallace, "The Malay Archipelago," London, 1869; Bleek, "Handbook of African, Australian, and Polynesian Philology," 3 vols., London and Cape Town, 1858-'63; Friedmann, *Die Ost-Asiatische Inselwelt*, Leipzig, 1868.)—Mongolians are all the inhabitants of the Asiatic continent, with the exception of the Hyperboreans in the north, a few Malays in the southeast, the Dravidas in Further India, and the Mediterraneans in the southwest. The species is represented in Europe by the Finns and Lapps in the north, the Osmanlis in Turkey, and the Magyars in Hungary. The color of the skin is yellow, with either a white or a brown tinge; the hair is straight and black; the head is either short or medium in size, long heads being rare; the face is round; the eyes are small, and often oblique; the cheek bones protrude; the nose is broad, and the lips are thick. The languages of the Mongolians can be retraced to one primitive tongue, which separated at a very remote time into two main branches: the monosyllabic languages of the Indo-Chinese, and the polysyllabic languages of the other Mongolian races. The Thibetan, Burmese, Siamese, and Chinese belong to the former. The polysyllabic Mongolians are divided into three races: the Coreo-Japanese, comprising the Coreans and the Japanese; the Altaians, including Tartars, Kirghiz, Calmucks, and Tungusians; and the Uralians, with the Samoyeds and Finns. Kindred to the last named are the Magyars of Hungary. The Arctic or polar races also seem to descend from the Mongolians. They include the inhabitants of the arctic regions of both hemispheres: the Esquimaux proper and Greenlanders in North America, and the Hyperboreans in N. E. Asia. Acclimation transformed these races so peculiarly as to render it natural to classify them as a separate species. They are low in stature; their heads are medium-sized, and occasionally

long; their eyes are small and somewhat oblique; their cheek bones protrude; their mouths are large; their hair is straight and black. The color of the skin is more or less brown, sometimes with a white or a yellow tinge, like the Mongolians, and sometimes with a ruddy tinge, like the Americans. Their languages differ from the American and Mongolian. The Americans or redskins were the only inhabitants of America at the time of its discovery. The two preceding species are the nearest related to them. The head is generally medium-sized, rarely short or long; the forehead is broad and low; the nose large, protruding, and often aquiline; the cheek bones are prominent, and the lips rather thin; the hair is straight and black; the color of the skin is ruddy, becoming sometimes copper-colored, sometimes whitish, sometimes yellow-brown, and sometimes olive-brown. The numerous languages differ from each other considerably, but are essentially uniform in structure. (See AMERICAN INDIANS, and AMERICAN INDIANS, LANGUAGES OF.) It is probable that America was first peopled by Mongolians, who entered over the N. N. E. point of Asia, and from whom also the Arctic probably descend. It is not unlikely that Polynesians also entered America from the west.—The three species still to be noticed, Dravidas, Nubians, and Mediterraneans, have many characteristics in common, which separate them entirely from the others. The most noticeable feature is the development of a strong beard, which is either entirely wanting or but little developed in the other species. The hair is not quite as straight and smooth, but always more or less curly. The oldest of the three species are undoubtedly the Dravidas, who seem to have occupied the whole of India from Cape Comorin to the source of the Ganges, and to have spread as far as Beloochistan. Pushed by the Aryans or Indo-Europeans, they retired further south; they inhabit at present only the southern portion of the Indian peninsula and the island of Ceylon. The Dravidas resemble in some points the Australians, Malays, and Mongolians, as well as the Mediterraneans. The color of the skin is shaded from light brown to dark brown; the hair is neither straight nor woolly, but more or less curly, and the beard is well developed; the face is oval, the forehead high, the nose prominent and thin, and the lips are not thick. Their language is now strongly intermixed with Indo-European elements, but seems to descend from a peculiar primitive tongue. (See Caldwell, "Comparative Grammar of the Dravidian Family of Languages," London, 1856; Schlagintweit-Sakunlunski, *Reisen in Indien und Hoch-Asien*, 3 vols., Jena, 1869-'73 *et seq.*)—The Nubians include not only the Shangallas and Dongolese, but also the Foolahs must be counted as such. The Nubians proper inhabit the regions of the upper Nile: Dongola, Shangalla, Barabra, and Kordofan;

the Foolaahs moved further west, and inhabit now a broad district south of the western Sahara, between the Soodanese in the north and the Nigritians in the south. The Nubians and Foolaahs are generally classified either with the negroes or with the Hamitic races, and accordingly as Mediterraneans; but their peculiarities are great enough to constitute them a distinct species. The color of the skin is a yellow-brown or red-brown, and but seldom dark brown or black. The hair is not woolly, but generally curly, though frequently quite smooth; it is either dark brown or black. The growth of the beard is much fuller than with the negroes. The oval face gives them a Mediterranean type. The forehead is high and broad; the nose prominent and not flat; the lips are not puffy; and the languages spoken by the Nubian races have no connection with the tongues of the negroes proper. (See Arnaud d'Abbadie, *De l'Afrique centrale, ou voyage de S. A. Mohammed Saïd Pacha dans les provinces du Soudan*, Paris, 1857; and Antoine d'Abbadie, *Géodésie d'Éthiopie*, Paris, 1860-'63, which contains a number of Nubian vocabularies.)—The Mediterraneans have always been considered the best developed and most cultivated species. They were formerly classified as Caucasians, but the term was abandoned on account of the insignificance of the proper Caucasian branch, and Mediterranean was substituted because the most important races of this species flourished first on the shores of that sea. The Mediterraneans are now scattered over the whole world, and as a species they have no equal physically and mentally. The skin is as a rule of a light color, but appears in all tinges from a pure white or a ruddy white, through yellow and yellow brown, to dark and even black brown. The hair is generally rich in growth, and more or less curly, and the beard is fuller than with any other species. The skull is rather broad, and medium-sized heads are more common than others. No other species has an equally symmetrical development of the body. The languages of the Mediterranean races have not yet been retraced to a single primitive tongue; and at the present stage of philology four distinct languages are accepted as the earliest known antecedents of the languages now spoken. In harmony with this result, it is still necessary to divide the Mediterranean species into four races, which are only connected by the roots. Two of these races, the Basques and the Caucasians, are represented by only very small remnants. The Basques formerly inhabited the whole of Spain and the south of France, but are now reduced to about 800,000, dwelling near the northern coast of Spain, at the foot of the bay of Biscay, and a few on the French frontier. (See BASQUES.) The remnants of the Caucasian race are now confined to the Caucasian highlands. Their language, as well as that of the Basques, has no similarity with either the Aryan or the

Semitic tongues. (Consult Cuno, *Forschungen im Gebiete der alten Völkerkunde*, Berlin, 1871 et seq.). It has been attempted to prove that the Semitic and Aryan languages come from one common stock, as by Delitzsch in his *Studien über indo-germanisch-semitische Wurzelverwandschaft* (Leipsic, 1873); but the evidence is not quite sufficient. The two races must have separated at a very remote period. The Semitic race divided very early into the Egyptian and the Arabian branch. The Egyptians or Africans, also called Dyssemites, are by some entirely separated from the Semites, with the designation of Hamites. They embrace the ancient population of Egypt; the large group of Berbers who now inhabit the whole of North Africa, and formerly inhabited also the Canary islands; and finally the group of Ethiopians, Bedshas, Gallas, Danakils, Somaui, and other tribes, who people the coastland of N. E. Africa as far as the equator. The Arabian or Asiatic branch, also called Eusemites, and sometimes designated as Semites proper, embraces the inhabitants of the Arabian peninsula, and the highly cultivated group of Hebrews or Jews, and Arameans or Syrians and Chaldeans. The Himyarites, an offshot of the South Arabians, have peopled Abyssinia and pushed into the adjacent countries. (See Renan, *Histoire comparée des langues sémitiques*, 2d ed., Paris, 1858).—The Indo-European race has surpassed all other races in intellectual development, and separated like the Semites at a very early period into two branches: the Aryo-Romanic and the Slavo-Germanic. The former produced the Aryans in the narrower sense, or Hindoos and Iranians, and the Græco-Romans, comprising the Greeks and Itali, and according to many authorities the Albanese and Celts; the latter the Slavs and Letts, with the Russian, Bulgarian, Czech, Polish, Serb, and Baltic stems, and the Germanic nations, comprising Scandinavians, Germans, Netherlanders, and Anglo-Saxons. (See Fr. Spiegel, *Das Umland der Indogermanen*, Leipsic, 1871, and *Eranische Alterthumskunde: Geographie, Ethnographie und älteste Geschichte*, Leipsic, 1871 et seq.).—On the accompanying ethnological chart are shown the supposititious migrations and distribution of the human race from a continent now sunk under the level of the Indian ocean, to which Sclater has given the name of Lemuria. The cradle of the race is not known, and all the locations assigned to it are only hypothetical. Those ethnologists who give a plural origin to mankind account for the present distribution of the races by tracing their migrations to several starting points or primitive homes. The majority of ethnologists adopt, however, the monophyletic hypothesis, and regard the southern part of Asia as the birth-place of man, placing it either in the highlands of the Himalayas, or near the sources of the Oxus and Jaxartes, or between the Euphrates and Tigris, or in the southern part of Arabia,

or on the ancient continent of Lemuria. The chart traces the migrations of races from the last named region, as with a few small changes it can be made to answer all other hypotheses. Benfey, L. Geiger, and other students of the ancient Indo-European languages, have recently advanced the opinion that the original home of the Indo-European races must be sought in Europe, because their stock of words is rich in names of plants and animals, and contains names of seasons, that are not found in tropical countries or anywhere in Asia. But to establish where the Indo-European races were seated at any time, however remote, is not, as many believe, establishing the first home of the Semites, and much less of all mankind. The following table will show the relation which the most important living or historical races hold to each other, according to the more prevalent ethnological views:

ARYANS OR INDO-EUROPEANS.	SEMITES.
I. ARYO-ROMANS.	I. HAMITES OR DYSEMITES.
A. Aryans proper.	A. Mesopotamians (extinct).
1. Iranians.	I. Assyrians.
II. Indians.	II. Babylonians.
B. Græco-Romans.	III. Ancient Phœnicians.
I. Old Thracians.	B. Ancient Egyptians.
a. Græcks.	I. Copts or Modern Egyptians.
b. Albanese.	II. Ethiopians.
II. Italo-Celts.	a. Bedshas.
a. Itali.	b. Danakils.
1. Latins.	1. Soumauli.
2. Romans.	2. Gallas.
b. Celts.	III. Libyans.
1. British.	a. Berbers (Amazirghs).
a. Gauls.	1. Tuariks.
b. Old Britons.	2. Kabyles.
2. Gael.	a. Tunese.
a. Irish.	b. Algerians.
b. Old Scots.	3. Shellooks.
II. SLAVO-GERMANS.	4. Guanches.
A. Slavo-Letts.	II. EUSEMITES, OR SEMITES PROPER.
I. Slavs.	A. North Semites.
a. Southeastern Slavs.	I. Canaanites.
1. Russian.	a. Phœnicians.
2. Southern Slavs.	b. Jews (Hebrews).
b. Western Slavs.	II. Arameans.
1. Czechs.	a. Syrians.
2. Poles.	b. Chaldeans.
3. Serbs.	c. Samaritans.
II. Baltics.	B. Arabs or South Semites.
a. Old Prussians.	I. South Arabs.
b. Letts.	a. Himyarites.
c. Lithuanians.	b. Abyssinians.
B. Old Germans or Teutons.	c. Amharas.
I. Goths.	1. Harraras.
II. Scandinavians.	2. Tigri.
III. Germans.	II. Moors or Koranites.
a. Low Germans.	
1. Frisians.	
2. Saxons.	
a. Old Saxons.	
Netherlanders.	
Low Germans.	
b. Anglo-Saxons.	
High Germans.	

The prominent races are described in separate articles.—Another question of interest is to determine the period in which man made his first appearance upon earth. Modern geology and archæology have rendered valuable assistance toward its solution, and at the present stage of these sciences it seems most probable that the time of man's advent must be placed in the tertiary or in the beginning of the dilu-

vial age. It is certain that human beings lived in central Europe as early as the latter period. (See ARCHÆOLOGY, BONE CAVES, GEOLOGY, and LAKE DWELLINGS.) Concerning the prehistoric races too little is known for a satisfactory ethnological classification of them. Fergusson suggests in his recent work entitled "Rude Stone Monuments in all Countries" (London, 1872) an arrangement of these races into five groups, with subdivisions, according to the degree of art exhibited and the material employed in the construction of the primitive sepulchres. They are designated accordingly as either tumulus, dolmen, circle, avenue, or menhir builders. The characteristics of these sepulchral remains are stated in the article FINDS.—Besides the works already mentioned, the following are among the most important recent publications on the subject: Lyell, "The Geological Evidences of the Antiquity of Man" (London, 1863); Waitz, *Anthropologie der Naturvölker* (5 vols., Leipsic, 1860-'70, continued by Gerland); Hervey Saint-Denys, *Collection ethnographique photographique* (Paris, 1864 et seq.); Carl Vogt, *Vorlesungen über den Menschen, seine Stellung in der Schöpfung und in der Natur* (2 vols., Giessen, 1864); Schleicher, *Ueber die Bedeutung der Sprache für die Naturgeschichte des Menschen* (Weimar, 1865); Bastian, *Die Völker des östlichen Asiens* (6 vols., Leipsic and Jena, 1866-'71), and *Die Rechtsverhältnisse der verschiedenen Völker der Erde* (Berlin, 1872); Lubbock, "Prehistoric Times" (London, 1867), and "The Origin of Civilization and the Primitive Condition of Man" (1870); Denison, "Antiquity of Man" (London, 1868); Hæckel, *Ueber die Entstehung und den Stammbaum des Menschengeschlechts* (Berlin, 1868); Friedrich Müller, *Ethnographie: Reisen der Fregatte Novara, Anthropologischer Theil* (Vienna, 1868), and *Allgemeine Ethnographie* (1873); Baldwin, "Prehistoric Nations" (New York, 1869); Mme. Clémence Royer, *Origine de l'homme et des sociétés* (Paris, 1870); Büchner, *Die Stellung des Menschen in der Natur, in Vergangenheit, Gegenwart und Zukunft* (Leipsic, 1870); J. G. Wood, "The Natural History of Man" (London, 1870); Charles Darwin, "The Descent of Man" (2 vols., London, 1871); Edward B. Tylor, "Primitive Culture: Researches in the Development of Mythology, Philosophy, Religion, Art, and Culture" (2 vols., London, 1871); Bray, "Manual of Anthropology" (London, 1871); and the periodicals, the London "Journal of Ethnology," "Journal of the Anthropological Institute of New York," and Bastian's *Zeitschrift für Ethnologie* (Berlin.)

**ETHYLE** (Gr. *αἰθήρ*, upper air, and *ἔλη*, material), the name given by Berzelius to what was then a hypothetical body, which he considered, and which has since been proved to be, the base of ether and alcohol; ether being the oxide and alcohol the hydrated oxide of ethyle. It was not isolated during his life, but in 1849

Dr. Frankland obtained it by the action of zinc upon iodide of ethyle at a high temperature. Its formula is  $C_2H_2$  when in combination; but when free it is regarded as the double of this,  $C_4H_4$ . It is a colorless, inflammable gas, having a slight ethereal odor (of which it would probably be devoid if absolutely pure) and a specific gravity of 2.00394. At a pressure of 2.25 atmospheres, and a temperature of  $37^\circ F.$ , it becomes a colorless, transparent, mobile liquid. It is nearly insoluble in water, but soluble in absolute alcohol. It enters into the composition of a great number of compounds, comporting itself in the manner of a monatomic basylous radical, analogous to hydrogen and potassium, the chloride, bromide, nitrate, &c., containing one atom of  $C_2H_2$ ; the oxide, sulphide, neutral sulphate, and other neutral ethyle salts of dibasic acids containing two atoms of  $C_2H_2$ ; and those of tribasic acids, three atoms of  $C_2H_2$ . It also unites with other alcohol radicals, producing compound alcohol radicals having a composition analogous to ethyle itself.

**ETNA** (Lat. *Ætna*, probably from Gr. *aiten*, to burn), a volcano of Sicily, called by the inhabitants of the island Mongibello, from a combination of the Italian *monte* with the Sara-

enic *jebel*, also meaning mountain. It rises from the E. coast of the island, midway between its N. and S. extremities. The port of Catania is on the prolongation of its S. foot, and, as its history shows, is by no means beyond the reach of its devastating lava currents. North of the mountain is the Val di Demone, watered by the river Alcantara; and 30 m. S. of it is the N. margin of the Val di Noto, in which the waters of the Giaretta find their way toward the coast amid the ancient scoriae of the great volcano. The country between these rivers is occupied by the mountain with its various ridges, volcanic cones, and deep depressions, which cover altogether an area of about 87 m. in circumference; yet the lava has spread far beyond these limits. In the midst is the apex of the great conical mass, the highest summit, as ascertained by Sir J. Herschel in 1824, being  $10,872\frac{1}{2}$  ft., or 10,835 according to a measurement adopted by Petermann in his latest maps. The latitude of the point is  $37^\circ 43' 31'' N.$ , the longitude  $15^\circ E.$  The cone, at the summit of which is the great crater, is in the midst of a comparatively level region, 9 m. in circumference, the highest point being 1,100 ft. below the principal apex. Around the mountain, at its base, is a fertile

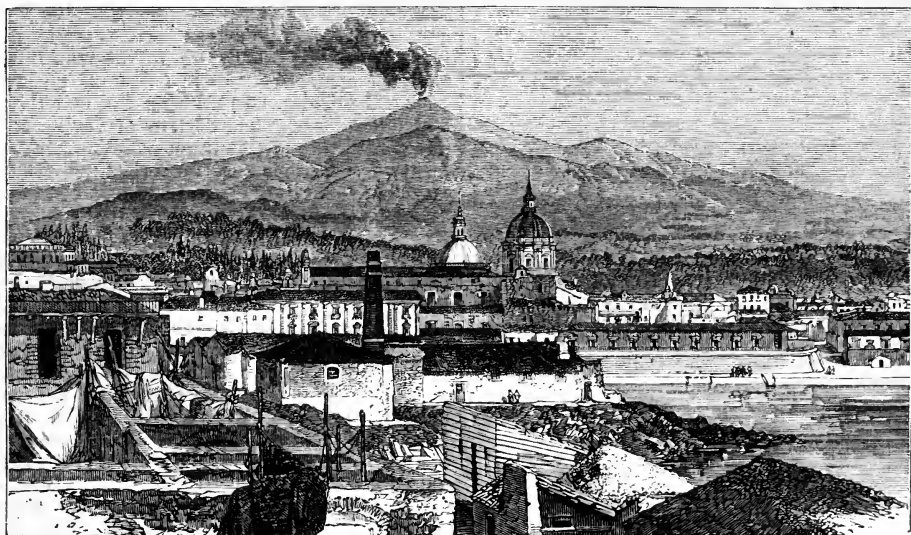

Mount Etna from Catania.

and delightful region known as the *regione culta*. Near Catania this is 11 m. broad, till one reaches in ascending the *regione silvosa*, or woody district; but on the N. side the wood skirts the mountain to within half a mile of its foot. This lowest belt is the region of cultivation; towns and villages are clustered upon it; and in the rich soil of the decomposed lava and tufa are flourishing plantations of olives, vines, grain, fruits, and aromatic herbs. Though in the frequent eruptions some of these are often

swept away, or buried beneath the flow of lava, the attractions of the delicious climate, and of a soil so productive, overcome the fears of a people familiar with the danger, and render them comparatively indifferent to the annoyances of the sharp volcanic dust. The woody region encircles the mountain in a belt 6 or 7 m. in width; but the extensive forests are much broken in upon by the ravages of the lava. Here are fine groves of chestnut and cork trees, and in the higher portions pines of great magni-

tude abound, together with oak, beech, poplar, and hawthorn of immense size. The most famous of these trees is the gigantic chestnut tree seen from Aci Reale, which is, however, described by Capt. Smyth as a cluster of what appeared to be seven trees growing together, the largest of which measured 38 ft. in circumference, and the whole 163 ft. This region affords pasturage for many herds and flocks. Its elevation gives it a cooler and more agreeable temperature than that of the lowest belt. At the height of 5,362 ft. is the Goats' cavern or grotto, frequented by these animals in bad weather, and formerly a resting place for travellers, until the shelter known as the English house was built immediately under the cone, at the height of 9,592 ft., at the expense of some British officers who were stationed in Sicily. The upper edge of the woody region is estimated at about 6,000 ft. above the sea. Beyond it is the cold and desolate zone of the mountain called the *regione deserta*. Its surface spreads out in broad tracts, compared to plains, which are rough and black with the naked lava and scoriæ, or white with drifts of snow, which perpetually cover the highest summits. These also collect in the crevices and grottoes of this portion of the mountain, and furnish supplies of ice to the inhabitants of the island, and of Malta and the neighboring region of Italy. In 1828, when the whole country was parched with the excessive heat, a quarry of perennial ice was opened under a stratum of lava, so situated that this must have flowed in a melted state at some distant period over the snow, which, as suggested by Sir Charles Lyell, was no doubt protected from the action of the heat by a previous covering of fine dust and scoriæ. The great crater is on a mountain of stones and ashes, which rises about 1,100 ft. above its base in this snowy tract. The diameter of its mouth is estimated by different travellers at from  $\frac{1}{4}$  to  $\frac{1}{2}$  m., and the depth from 600 to 800 ft. Sulphurous smoke and rumbling noises issue from it continually. The view from this summit at sunrise is magnificent. The mountain itself, lying directly beneath the eye of the observer, which can penetrate into the inferior cones upon its flanks, presents the most original feature of the landscape. The cones, however, are best seen from the lower borders of the desert region. Of these secondary volcanoes Lyell enumerates 80 which are of considerable dimensions, and one of these, called Monte Minardo, near Bronte, is 700 ft. high; and the double hill Monti Rossi, near Nicolosi, formed in 1669, is 450 ft. high, with a base 2 m. in circumference. They are produced by lateral eruptions in the desert region or in the wooded belt below. In the latter their height is reduced by the flow of lava from higher sources, which gathers around, and in some instances buries them and even pours into their craters.—The earliest recorded eruption of Etna is one mentioned by Diodorus Siculus, which caused the Sicani to desert its vicinity and

move further to the south. No date is given, but it appears to have happened before the Trojan war. The next are three eruptions referred to by Thucydides, of which, according to his narrative, one was in 475 B. C., one in 425, and one at an earlier time not clearly specified. These, added to the later recorded eruptions to the present time, make about 70 in all. The most important are those of 1169, 1669, 1755, 1787, 1792, 1852, and 1868. An earthquake in March, 1669, destroyed all the houses in the village of Nicolosi, 10 m. from Catania, near the lower margin of the wooded district. Streams of lava not many days afterward broke forth from chasms which opened in different parts of the mountain. These destroyed as many as 14 villages. From a gulf that formed near Nicolosi, sand and scoriæ were projected that produced in the course of three or four months the double cone Monti Rossi. A fissure 12 m. long was formed, which emitted a most vivid light, and extended to within a mile of the summit of Etna. Afterward five other parallel fissures opened, which gave forth smoke and loud bellowing noises. These fissures, which were without doubt partially filled with lava, afford an illustration of the manner in which the porphyritic dikes are formed, which are seen cutting the lavas, and projecting in the form of walls from the precipitous sides of the deep valleys of the mountain; and also of the origin of the trap dikes of older formations. By the flow of the lava among the deep caverns within the mountain, its vaulted foundations were melted away, and the crest, rent with numerous fissures, settled into the vacant spaces. To protect the city of Catania, its walls next the mountain had been raised to the height of 60 ft.; but the lava rose steadily till it overtopped the rampart, and poured a cascade of liquid fire into the midst of the houses. Long afterward, when excavated by the prince of Biscari, the solid lava was brought to view, its layers curling over the wall, as if just petrified in their flow. Its rate of progress varied greatly with the consistency of the melted matter and the slope of the surface. The greater part of the 15 m. of its flow to the sea was accomplished in 20 days, but the last 2 m. were only at the rate of 22 ft. an hour. Its surface exposed to the air was a crust of solid rock; through the side walls streams of the fluid lava often burst out, and by excavating into the great current at suitable places the flow might be diverted in new directions. Attempts to do this by some of the inhabitants of Catania, to protect their town, were opposed with arms by the people of Paterno, as the new current threatened to bring destruction upon their habitations. In some places hills of older lava were melted into the flowing stream. In others the cooling matter taking an arched form protected objects on the surface by enclosing them in grottoes of lava. Thus were preserved many valued articles from one of the churches of Mompigliere,



afterward obtained by excavating 35 ft. into the solid lava. This lava current was so hot at Catania eight years after it entered the town, that it was impossible to hold the hand in some of the crevices. The great lava current as it flowed into the sea had spread over a width of 600 yards, and its depth was estimated at 40 ft. The water was thrown into violent commotion. Sounds louder and more terrific than peals of thunder were constantly sent forth, and the light of the sun was darkened by the clouds of vapor. The fish were destroyed along the coast, and many months passed before the water became again clear and transparent.—The eruption of 1755 is remarkable for a great inundation caused by the flow of two streams of lava upon a vast collection of snow. For 8 m. down the flanks of the mountain the torrent poured, sweeping on the loose scoriæ and blocks of lava, which were deposited in the plains below. The inhabitants believed that the water was discharged from the crater itself, and the stories of its saltness and of the marine shells contained in it are still found in the popular accounts of this eruption.

**ETON**, a town of Buckinghamshire, England, on the left bank of the Thames, opposite Windsor, 22 m. W. of London by road; pop. about 3,000. Its college, the most celebrated of English public schools, was founded by Henry VI. in 1440, and endowed by a gift from his own demesne lands and those belonging to some priories whose revenues had been appropriated to religious houses abroad. The original foundation

consisted of a provost, 10 priests or fellows, 4 clerks, 6 choristers, a master, 25 poor scholars, and as many poor men, or beadsmen. Henry VI. at the same time founded King's college, Cambridge, to which Eton was to be preparatory. The first stone of the building was laid July 3, 1441. In 1443 Henry VI. increased the number of scholars to 70 and reduced the beadsmen to 13. At present the foundation consists of a provost appointed by the crown, a vice provost, 6 fellows, 2 chaplains called conducts, 10 lay clerks, 10 choristers, besides inferior officers and servants, and 70 scholars, who since the reign of George III. have been called "king's scholars." As Eton was a Lancastrian foundation, it suffered under the rule of the house of York, and was curtailed by Edward IV. of many of its possessions. More fortunate under the Tudors, Eton was specially excepted from the act of parlia-

ment passed in the time of Henry VIII. for the dissolution of colleges and chantries. At this period its revenues were estimated at £1,100. In 1506 the total income was £652. Its present income is about £7,000. The college buildings consist of two quadrangles, built partly of freestone, but chiefly of brick. The scholars on the foundation are lodged and boarded in the college, and by way of distinction are called collegers. They are admissible from the age of 8 to 16, and, unless put on the roll for admission to King's college at 17, are superannuated and obliged to leave at 18. If put on the roll, they may continue till 19. The foundation scholars must be born in England, of parents lawfully married. By the statutes they should be instructed gratis and clothed in some coarse uniform, but in neither of these points are the statutes adhered to. The sum of £6 or £7 per annum is charged to the parents of every foundation scholar who are able to pay it. Every year the 12 head boys are

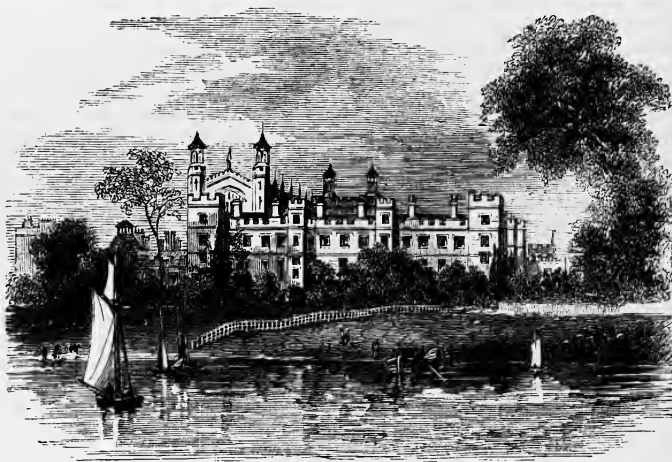

Eton College.

put on the roll of King's college, but continue at Eton until there is a vacancy or until superannuated. At King's college the Etonians are maintained free of expense, and after three years they succeed to fellowships. On an average four scholars go to King's college yearly. There are also two scholarships at Merton college, Oxford, for foundation scholars who are not elected for King's college. These latter are called *portionists*, or by corruption, postmasters. In 1842 Prince Albert instituted an annual prize of £50 for proficiency in the modern languages. The larger number of Etonians are not on the foundation, and are called oppidan; they do not board in the college. The annual expenses of an oppidan amount to about £150 or £200. The sixth form is the highest in the school, and is limited in number to 22; of these the highest 10 are styled monitors, and the head boy is called the captain. The

classes are divided between the lower and upper school. There are a head master and a lower master, 23 assistant masters in the upper school and 4 in the lower, 6 mathematical masters, and masters of the French, German and Hebrew, and Italian languages. The course of instruction was formerly almost wholly classical; but mathematics and modern languages are now a part of the curriculum. The annual elections take place in the last days of July every year. The usual number of scholars is between 700 and 800. The Eton mottom is a peculiar ceremony, formerly biennial, but after 1759 held triennially on Whit-Tuesday, and discontinued since 1844. On this occasion the boys marched in procession to an elevation on the Bath road called Salt hill, under the lead of the head boy of the foundation scholars as captain. Here they spent the day, partook of a bountiful breakfast and dinner, with music and various ceremonies, and collected toll from all spectators and passers-by. The scene was visited by great numbers of people, and even sometimes by the royal family, and the contributions, called salt, have been known to exceed £1,000. After deducting expenses, the remainder was paid over to the captain, who in 1847 was indemnified by the queen for his loss by the omission of the ceremony.—See "History of the School of Eton," by J. H. Jesse (London, 1872).

**ETOWAH**, a N. E. county of Alabama, intersected by Coosa river; area, about 500 sq. m.; pop. in 1870, 10,109, of whom 1,708 were colored. The Alabama and Chattanooga railroad passes through it. The surface is somewhat mountainous, but the soil is fertile. Forests abound. The chief productions in 1870 were 41,128 bushels of wheat, 181,034 of Indian corn, 16,745 of sweet potatoes, 13,791 lbs. of wool, and 1,383 bales of cotton. There were 923 horses, 4,623 cattle, 4,950 sheep, and 8,649 swine. Capital, Gadsden.

**ETRURIA**, or **Tuscía**, a division of ancient Italy, bounded W. by the Tyrrhenian sea, and separated on the N. W. from Liguria by the river Macra (now Magra), N. E. by the Apennines from Cispadine Gaul, and E. and S. by the Tiber from Umbria and Latium. It thus embraced the modern Tuscany, and some adjoining territories, and was a fertile and well cultivated country. Its principal mountains were the Ciminius (Monte di Viterbo) and Socrate (Monte di San Oreste). Its chief rivers were the Tiber and the Arnus (Arno); its chief lakes the Thrasymenus (lake of Perugia), the Lacus Vadimonis (Bassano), the Volsinensis (Bolsena), and the Sabatinus (Brocciano). The testimony of ancient writers, and late discoveries of antique monuments, comprising walls, *cloaca*, tombs adorned with sculptures, vases, coins, &c., prove that Etruria was inhabited by a civilized and cultivated people long before the foundation of Rome. They were called Etrusci or Tusci by the Romans, and Tyrrheni or Tyseni by the Greeks; their

national name was Ras, or with the gentle termination Ras-ennæ. They were distinguished from the Latin and Sabellian Italians, as well as from the Greeks, by their bodily structure, as the sculptures of the Etruscans exhibit only short sturdy figures with large heads and thick arms; by their religion, which was of a gloomy character, delighting in mystical handling of numbers and in horrible speculations and practices; and by the complete isolation of their language. For these reasons no one has as yet succeeded in connecting the Etruscans with any other race. Many dialects have been examined, and sometimes tortured, with a view of discovering some affinity, but in vain. The geographical position of the Basque nation suggested that the Basque language might be cognate to the Etruscan; but no analogies of a decisive character have been brought forward. The scanty remains of the Ligurians, and the sepulchral towers called *nuraghe*, which are found by thousands in the Tuscan sea, and especially in Sardinia, fail to evince relationship with the Tuscan people. As the oldest Etruscan towns lay far inland, it was conjectured that they migrated into the peninsula by land, and perhaps over the Rhatian Alps, for the oldest traceable settlers in the Grisons and Tyrol, the Rhæti, spoke Etruscan down to historical times, and their name has a resemblance to that of Ras. In strong contradiction to this opinion stands the view that the Etruscan language was Semitic, as well as the ancient tradition that the Etruscans were Lydians who had emigrated from Asia. The latter occurs in Herodotus; but Dionysius asserts that there was not the slightest apparent similarity between the Lydians and Etruscans in religion, laws, manners, or language. It is possible that the belief rested on a mere verbal mistake. The Etruscans or *Turs-ennæ* (which seems to be the original form of the Greek *Τυρσ-ηνοί*, *Τυρρηννοί*, and of the Roman *Tusci*, *Etrusci*) nearly coincide in name with the Lydian people, the *Τορρηννοί*; and Thucydides confounded their maritime commerce with the piracy of the Lydians, and the Torrhebian pirates with the buccaneering Pelasgians. Schwegler's opinion is that the Etruscans were driven into Rhætia by the Gauls. Livy's account is also at variance with the opinion given above (Mommsen's) that the Etruscans came from the north. The Roman historians generally represent the original Etruscan settlements to have been on the southern or Roman side of the Apennines, and that the Etruscans pushed forward northward to the Alps. It is thus still unexplained how the Etruscans came into Italy. They probably occupied at one time the plains of Lombardy, having subdued the Umbrians, and were then themselves driven out by the Celts or Gauls, about the time of Tarquinius Priscus, when part of them seem to have taken refuge in the mountains of Rhætia, and the remainder to have proceeded toward the south.—The few

Etruscan literary remains, as inscriptions on coins and tombs, fail to throw light on the question of their ethnological affinity, as the interpretation of the Etruscan language is still a matter of hypothesis. Dionysius of Halicarnassus and Bochart regard the Etruscan as an aboriginal language; Fréret and Sir William Betham make it Celtic; Ciampi and Kollar, Slavic; Micali, Albanese; Passeri, Gori, and Lanzi derive it from the Greek and Latin, and hold that the Umbric, Volscic, Oscic, and Samnitic are dialects of it; O. Müller thinks it akin to the Greek; others derive it from Rætia; others make it cognate to the Basque or the Finnish; and finally, Lami, Pfitzmaier, and others, suppose it to be Semitic, a hypothesis which in 1858 J. G. Sticckel was thought to have demonstrated to be the truth. In 1873 Prof. Corssen announced that he was about to publish a work on the subject that would show entirely new results. Taylor's "Etruscan Researches" (London, 1874) again endeavors to establish a Turanian relationship. The alphabet is believed to consist of 21 letters, almost coincident in form with the ancient Greek letters, written from right to left, but corresponding in value to those of the Hebrew, though not used as numerical signs. Of several hundred short funeral inscriptions known, 17 have been published as proofs of the Semitic character of the language; some of them are bilingual, with a Latin part giving the name of the deceased. There are also inscriptions on candelabra, drinking cups, and other utensils. Of inscriptions on coins there are but few. Under the Roman emperors the haruspices used Latin versions of Etruscan rituals. Such were the *libri Etrusci*, *Etrusca disciplina* (religion); rituals on the manner of building cities, temples, and altars; on the sanctity of walls and gates; on the *tribus*, *curiæ*, military order, &c.; *fulgurales* and *haruspici*, and the *prodigia*; *Tugetici*, on the ceremonies (*cæremonia*, from *Cære* or *Agylla*) of the earth-born god Tages; *acheruntici*, on conciliation with the gods, &c. There were also ancient pastoral and augural songs. Varro preserved some fragments, and mentions Etruscan tragedies by Volumnius. The histories to which Varro alludes were probably superstitious inventions similar to those preserved in Plutarch's life of Sulla. In the speech of the emperor Claudius, preserved on bronze plates at Lyons, is cited a version of the adventures of Servius Tullius from Etruscan authorities, and, as Niebuhr thinks, from native annals beginning with the year 407 B. C. It seems, however, that the Etruscan testimony adduced by Claudius is not entitled to credit. The scoffing and jocular Fescennine (so called from Fescennium, a city of Etruria) and Saturnalian verses were also derived from the Tuscans. Cicero, Aulus Gellius, Cæcina, Nigidius Figulus, and some later Romans translated and explained various Etruscan books, of which we have but fragments.—There is no doubt

that the inhabitants of Etruria proper formed a confederacy of 12 cities with adjacent districts, which are supposed to have been the following: Cære (now Cerveteri, Old Cære), Tarquinii (in Roman history the cradle of the Tarquins), Rusellæ (Roselle, remarkable for its monuments), Vetulonia (Torre Vecchia), Volaterræ (Volterra), Arretium (Arezzo), Cortona, (Cotrone), Perugia (Perugia), Volsinii (Bolsena), Falerii (Civita Castellana), Veii (Isola Farnese), and Clusium (Chiusi), the seat of King Porsena. They had flourishing colonies in Corsica, Ilva (Elba), and in Campania, where they are supposed to have founded (about 800 B. C.) a confederacy similar to that of Etruria. Their navy was powerful on the Mediterranean at a very early period; a legend mentions an attack upon the Argo, the ship of the Argonauts, by Tyrrhenian mariners. Their commercial vessels visited the eastern shores of the Mediterranean. The inhabitants of Cære were dreaded as pirates. Various remains attest their proficiency in the arts; the frequently occurring representations of festive entertainments, games, races, and dances, accompanied by music, prove their love of recreation, no doubt fostered by the mildness of the climate. They also had national assemblies for religious and political purposes, celebrated at the temple of Voltumna in Volsinii. Their religion resembled in most of its conceptions the polytheism of the Greeks and Romans; it appears, however, to have been deeper, gloomier, and less fanciful than that of the former. The names of many of their deities, who were divided into higher or hidden and other gods, and were believed to reside in the remotest north, seem to mark the transition from the Grecian to the Roman forms. Tina (Jupiter) presides over the council of 12 *consentes* or *complices*, probably personifications of the 12 constellations of the zodiac. They had lunar and solar divisions of time, and cycles of more than a century. Of their numerous sacred books, the principal of which were believed to contain the revelations of the demon Tages, the so-called Acherontic taught how to propitiate the gods, to delay fate, and to deify the soul. Many of their religious rites; those of augury for instance, were adopted by the Romans, who also imitated their games, insignia, and triumphal distinctions. Their priests, called *lucumos*, appear at the same time as heads of noble families and as kings or rulers of cities. They formed the senate of the confederacy, which seems to have consisted of loosely connected independent and sovereign members, at a later period ruled by magistrates chosen annually. The common people were dependent upon the priestly aristocratic families in a kind of feudal clientship, whose forms appear more servile than in the similar Roman institution. Freemen also occur in the history of some of the confederate cities, but as a politically unimportant class.—Walls of cities, sewers, vaults, subterranean tombs, and bridges are the only existing monu-

ments of Etrurian architecture. The Cloaca Maxima at Rome, which is believed to be an Etruscan work, shows that they were acquainted with the use of the arch. The paintings display archaic outlines and an unreal or fantastical coloring. The painted vases usually termed Etruscan, which are found in large numbers in the tombs of Etruria, but also in Campania, Sicily, and Greece, were probably the work of Greek artisans. Authorities differ on the question whether the vases were imported into Etruria or made by Greek workmen settled there. The Etruscans showed great skill in the manufacture of pottery; but the only kinds now assigned to them are the red ware of Arretium and the black ware of Clusium. The specimens of sculpture and carving in marble and wood discovered in the tombs, though very numerous, are not of a very superior order, and the ancient writers do not greatly admire the Etruscans in these arts. But the bronze statues of Etruria were very famous; they filled the temples of Rome, and it is said that the city of Volsinii alone contained 2,000 of them. Some were very large and heavy; Pliny says that the Apollo on the Palatine was 50 ft. high, and as wonderful for its enormous weight as for its beauty. Their greatest fame rests, however, on the artistic designs and skillful execution of decorative objects, as thrones, chariots of state, chandeliers, shields, shells, rings and other jewelry. Etruscan art was imitative rather than creative, and bore at every period the marks of foreign influence, especially Egyptian, Babylonian, and Hellenic.—Some Egyptologists are of opinion that the Takkara nation, mentioned on an inscription among the allies of the Libyans, at the invasion of Egypt during the reign of Rameses III., in the 13th century B. C., were Etruscans, and had a considerable fleet. Other authorities maintain, however, that the Etruscans did not dwell in Italy till a much later period. About 540 B. C. the Etruscans fought jointly with the Carthaginians the first naval battle recorded in the history of the western part of the Mediterranean, at Alalia, against the Phœceans, whom they defeated, gaining thereby possession of the island of Corsica. The subsequent treaties made by the Etruscans with the Carthaginians, reciprocally renouncing piracy in each other's waters, and prohibiting the establishment of colonies on each other's territories, have not been preserved, and Aristotle is the only ancient historian who makes mention of them. The most flourishing period of the history of Etruria comprises some centuries before and after the foundation of Rome. Some believe that the Tarquins were Etruscans, but others hold that they were of Corinthian origin. It does not seem probable that the Etruscans exercised a kind of dominion over their younger neighbor, as Müller, Becker, and Schwegler suppose. According to Livy, whose narrative is now, however, considered legendary, Por-

seno, king of Clusium, made war on Rome for the restoration of Tarquin the Proud, and compelled the Romans to a humiliating treaty. But scarcely had Rome gained peace from him when it commenced a protracted but eventually successful war with another Etruscan enemy, Veii. The distraction of the confederacy by frequent successful and devastating incursions of the Syracusans, by attacks of the Samnites upon its Campanian dependencies, the inroads of the Gauls under Brennus, and the two battles fought near the Vadimonian lake by Quintus Fabius (310) and Publius Cornelius Dolabella (283), finally broke the power of Etruria. The social relation to Rome, into which it entered in 280 B. C., was changed after the social war (90), in reward for its fidelity, into Roman citizenship. Soon afterward Etruria suffered greatly from the revenge taken by Sulla on the partisans of Marius in its cities. Whole districts were given as confiscated estates to the veterans of the dictator, who afterward became the accomplices of Catiline (63–62). Octavianus, too, had his military colonies in Etruria.—Among the numerous writers who have treated of the antiquities of Etruria, the most instructive are Lanzi, Inghirami, Niebuhr, Ottfried Müller, Hey, Wachsmuth, Hormayr, Steub, Dorow, Micali, Abeken, Secki, Lepsius, Gerhardt, Dennis, Mrs. Gray, Bunsen, Rossignol, Witte, Winckelmann, and Noël des Vergers (*L'Étrurie et les Étrusques*, 3 vols., Paris, 1864). In addition to the authorities mentioned in connection with the theories on the Etruscan language, see Dempster, *De Etruria Regali* (Florence, 1723–'4); Gori, *Difesa dell' alfabeto degli antichi Toscani* (Florence, 1742); Amaduzzi, *Alphabetum Veterum Etruscorum* (Rome, 1775); Vermiglioli, *Saggio di congetture*, &c. (1824); Kollar, *Staroitalia slovjanska* (Vienna, 1853); Mommson, *Nord-Etruskische Alphabete*; Crawford, "Etruscan Inscriptions" (London, 1873); Uhden, Kreuzer, Gesenius, Curtius, Heath, Dureau de la Malle, Beulé, Levy, Bargès, Renan, and Dr. Frick, in archaeological and philological periodicals.—The history of modern Etruria, a kingdom created by Napoleon in 1801, and given to Louis, crown prince of Parma, ruled after his death by his widow Maria Louisa of Spain as regent, and in 1807 annexed to France as a province, belongs to that of Tuscany (a name derived from the Roman *Tuscia*).

**ETTLINGEN**, a town of Baden, Germany, at the entrance of the valley of the Alb, 5 m. S. of Carlsruhe; pop. in 1871, 5,092. It has belonged to Baden since 1234, previous to which it was a free city. The town is noted for the large number of interesting Roman antiquities which have been found near it.

**ETTY**, William, an English painter, born in York, March 10, 1787, died there, Nov. 13, 1849. He was the son of a baker, and at the age of 12 was apprenticed to a printer at Hull, with whom he remained seven years. He studied at the royal academy and as a private pupil of Sir Thomas Lawrence, but was long

unsuccessful. In 1811 one of his pictures was admitted to the academy's exhibition; and in 1821 his "Cleopatra's Arrival at Cilicia," in which the nude female form was depicted with great correctness, and with a voluptuous glow of color, brought him into considerable notice. In 1822 he went to Italy, and spent many months in the study of the Venetian colorists. In 1848 an exhibition of his works was opened in London, prominent among which were the nine great paintings which he considered the triumphs of his artistic career, and in which he says he aimed "to paint some great moral on the heart." They comprise "The Combat," the three "Judiths," pictures, "Benaiah, David's Chief Captain," "Ulysses and the Sirens," and the three pictures of "Joan of Arc." Etty is considered one of the chief artists of the modern English school. He wrote an autobiography, which was published in the "Art Journal" for 1849; and his life has been written by A. Gilchrist (2 vols. 8vo, 1855).

**ETYMOLOGY.** See LANGUAGE.

**EU,** a town of France, in the department of Seine-Inférieure, on the Bresle, about 2 m. from its mouth in the English channel and 17 m. E. N. E. of Dieppe; pop. in 1866, 4,168. It has a fine Gothic church, with a famous subterranean chapel, and manufactures of lace, serges, and soap. The château d'Eu, in the neighborhood, was one of the favorite castles of Louis Philippe, and it now (1874) belongs to the count de Paris.

**EU, Louis Philippe Marie Ferdinand Gaston d'Orléans, count d',** a Brazilian general, born at Neuilly, April 28, 1842. He is the elder son of the duke de Nemours, and grandson of King Louis Philippe, and married in 1864 the princess Isabella of Brazil, heir apparent to the throne. He holds the rank of marshal in the Brazilian army. In 1869 he was commander-in-chief of the allied forces in the war against Paraguay, and achieved signal victories which impelled the retreat of Lopez in September, and led to his overthrow and death early in 1870. Previous to leaving Paraguay he proclaimed the abolition of slavery, and a number of slaves were emancipated in Brazil in 1870 in honor of his services.

**EUBŒA** (Ital. *Negroponte*; Turk. *Egripo*), an island of Greece, the largest of the archipelago, lying in the Ægean sea, between lat. 37° 57' and 39° 3' N., and lon. 22° 48' and 24° 35' E.; area, about 1,400 sq. m.; pop. in 1870, 82,541. It is separated from the coasts of Attica, Bœotia, Locris, and Phocis by a channel called Talanti in its northern part, Egripo in its southern, and about midway, where the coasts are only about 200 ft. apart, the strait of Euripus. At this point it is connected with the mainland by a bridge. On the north the channel of Trikeri separates it from the coast of Thessaly, and on the south the channel of Doro from the island of Andros. Eubœa is long and narrow, being about 100 m. in length, and varying from 6 to 30 m. in breadth. The E.

coast is rocky, irregular, and destitute of harbors. The rocks, which rise almost precipitously from the water, are seldom interrupted by open places, excepting at the N. end. The W. coast has several good harbors. A range of mountains runs through the entire length of the island, culminating in the peak of Delphi, near the middle of the chain, which is 5,730 ft. high. Mt. Kandili, on the W. coast, is 3,967 ft. high; St. Elias, at the S. E. end, 4,840 ft. These peaks are mostly barren. In some parts the mountains are clothed with luxuriant woods, chiefly pines, oaks, and ilexes, with an undergrowth of flowering shrubs, among which are the arbutus, cistus, and oleander. The slopes, which furnish abundant pasturage, are dotted with magnificent trees, and resemble the most beautiful parks in their scenery. There are no rivers, and no streams large enough to admit a boat, but the soil is exuberantly rich and productive. In the north the vine grows luxuriantly, and a red wine of good quality is made in considerable quantities. In the south corn and oil are the principal crops. Fruits also grow in abundance. A number of English and French proprietors, who have settled in the island, have given a favorable impulse to agriculture and done much for the advancement of the people. The principal exports are grain, wine, oil, honey, cheese, cotton, wool, and hides.—The early history of Eubœa is involved in obscurity. In historical times it was inhabited by Ionic Greeks, and was divided between six or seven independent cities, of which Chalcis and Eretria were the most important. They had an extensive commerce, and founded colonies in Macedonia, Italy, Sicily, and the islands of the Ægean. After the Persian war the whole island became subject to the Athenians, who regarded it as the most valuable of their foreign possessions, as it furnished them with corn, timber, and firewood, and with pasture for their horses and cattle. After the battle of Cheronœa (338 B. C.) it formed a part of the Macedonian dominions until after the battle of Cynoscephalœ (197), when its cities formed alliances with the Romans and recovered their independence; but the island was soon incorporated with the Roman province of Achaia. On the dismemberment of the Byzantine empire it fell to the Venetians, from whom it was wrested in 1470 by the Turks, who held it until the Greek insurrection of 1821. It now forms, with the islands of Skyro, Scopelo, Skiatho, and some others, the nomarchy of Eubœa; area, 1,573 sq. m.; pop. in 1870, 82,541.

**EUBULIDES OF MILETUS,** a Greek philosopher, the best known disciple of Euclid of Megara, flourished about the middle of the 4th century B. C. His life was a struggle against Aristotle, in which by a captious logic he sought to prevail against good sense. A partisan of the Megaric principle, that there is nothing real but what is always one, simple, and identical, he immediately found an adversary in the

founder of the great contemporary school which made experience the condition of science. He attacked the peripatetic doctrine, like Zeno of Elea, by striving to show that there is none of our experimental notions which does not give place to insolvable difficulties. To this end he invented his famous sophisms, of which the following is a specimen: "Some one lies, and says that he lies. Does he lie, or not? By the hypothesis, he lies. Then he does not lie, for what he says is true. Thus he lies and does not lie at the same time, which is contradictory."

**EUCALYPTUS** (Gr. *εὐ κάλυπτος*, well covered), a genus of myrtaceous trees, mostly natives of Australia and the Indian archipelago. The calyx tube is turbinate or campanulate; sepals united in a calyptra or cover, which separates in flowering by a fissure at the base, carrying the petals with it; stamens indefinite, free, with threadlike filaments; anthers versatile, opening longitudinally; ovary 3-4-celled; style filiform, stigma small; seeds usually angular, with a membranous testa. While in many species the flowers are small and inconspicuous, they are large in *E. macrocarpa*, and rendered showy by the carmine color of the numerous stamens. Sometimes the eucalypti are found in greenhouse collections, but in pot culture they are kept as mere shrubs. *E. Preissiana* and others are used in Europe for this purpose. The eucalypti are lofty trees, often attaining a height of nearly 250 ft. and a circumference of 70 ft. at the base. The leaves on young trees are opposite, on old usually alternate, coriaceous, entire, and feather-veined. About 100



*Eucalyptus macrocarpa*.

species are recognized, mostly belonging to Australia, where they form 99 per cent. of the forest vegetation, and afford large supplies of honey to bees. *E. gigantea*, the "stringy bark," is a valuable timber tree, and the *E. globulus* or bluegum is even better. The wood is hard and heavy, and well adapted to cabinet

work. The latter has been raised in southern Europe, and has been largely planted in Algeria and in some parts of British India. It succeeds remarkably in California, where its growth is exceedingly rapid. *E. resinifera* produces a gum much resembling kino, and called Bot-



*Eucalyptus Preissiana*.

any Bay kino. *E. robusta* has cavities in the stem between the annual rings, which contain a brilliant red or vermilion-colored gum. From *E. mannifera* and *E. dumosa*, during the dry season only, a kind of manna is obtained resembling the officinal manna in its properties, but of a more agreeable taste. *E. piperita* yields an essential oil sold as a medicine in the eastern bazaars. *E. Gunnii* when wounded gives a sap cool and refreshing and slightly aperient; the Tasmanians allow this to ferment, when a pleasant beer results. Almost all the species contain much tannin in the bark, which has been profitably extracted in Australia and sent to England.—A new interest has been given to the genus by the discovery of properties in the leaves and bark of several species resembling those of the cinchona or Peruvian bark, and much more abundant. The *E. globulus* (bluegum) is the species supposed to be most efficacious in marsh and other fevers, and is known in Spain as the "fever tree." Vauquelin obtained in analysis an essential oil containing eucalyptal or eucalypt camphor, and a resin closely resembling resin of cinchona. This extract yielded a substance capable of neutralizing the strong acids, and forming crystalline salts. The sulphate crystallizes in star-shaped crystals like the sulphate of quinia or cinchona, and presents the green coloration on the action of chlorine and ammonia supposed to be peculiar to that salt. The part of the tree most used in medicine is the leaves dried and powdered, although the bark and even the wood have produced favorable results.

**EUCHARIST.** See LORD'S SUPPER.

**EUCHRE**, a game of cards, usually played by two or four persons with a pack from which all the cards from 2 to 6 inclusive have been withdrawn. Before commencing the game, the players draw for the deal, which belongs to him who first draws a knave. The pack having been cut by his opponent, or, in four-handed euchre, by his right-hand adversary, the dealer distributes five cards to each player, including himself, commencing at his left, and giving first two and then three, and turns up the 11th card (in four-handed euchre the 21st). The cards have the same relative value as in whist, except that the knave of trumps, called the right bower, is the highest card in the pack, and the other knave of the same color, called the left bower, the next highest; after which come ace, king, &c. Players must in all cases follow suit, and the left bower is invariably to be considered a trump. The game consists of five points. The deal having been completed, the elder hand has the privilege of deciding whether the suit turned up shall be trumps. If he desires to retain it as such, he "orders up" the trump card, in which case the dealer rejects a card from his hand and takes that which he has turned up. In that case, however, the elder hand must take three tricks, constituting a point, or he is, technically speaking, "euchred;" that is, his adversary is entitled to score two points. If, on the other hand, he does not choose to order up the card, he says, "I pass," and the same privilege, with similar conditions, belongs to the next player, and so on. When all the players, including the dealer, have passed, the latter turns down the card, and the elder hand has the privilege of designating the suit which shall be trumps, which must however be another than that previously turned up. If he names a trump, he must score his point or be euchred; and if he is unwilling to take the risk, he passes again. When all the players have passed for the second time, they throw up their cards, and the elder hand succeeds to the deal. A player making all five tricks makes what is called a "march," and is entitled to score two; taking either three or four tricks, he scores but one. In four-handed euchre, in which the players sit opposite to each other are partners, as in whist, a player having good cards will sometimes desire to "play the hand alone," without the assistance of his partner. If under these circumstances he makes a march, he scores four points; but if euchred, his adversaries score two. The game has been recently modified by the addition of a blank card, called "the yerker" or "little joker," which is the highest in the pack. The game is sometimes played by three persons, in which case any two will combine against the third who may have "taken up" the hand; if they succeed in euchring him, each of them scores two points. This is sometimes called "the cutthroat game," since either of the three players is at any time liable

to be opposed by the other two.—The game of euchre is peculiar to the United States, where it is a universal favorite, being preferred by many to whist. Its origin is not known with certainty, but it is supposed to have been invented in Pennsylvania. It has been recently introduced into England.

**EUCLID** (Gr. *Εὐκλείδης*), the most celebrated of ancient geometers, flourished at Alexandria in the reign of the first Ptolemy, about 300 B. C. The Arabic historians give many unauthenticated particulars of his life; but it is only certain that he dwelt first in Greece and then in Egypt; and it is probable that he studied at Athens under the successors of Plato, and afterward passed over to Alexandria. There he founded the mathematical school, and was remarkable for his zeal in science, his affection for learned men, and his gentle and modest deportment. Ptolemy having asked him if geometry could not be made easier, he made the celebrated answer that there was no royal road to geometry. To appreciate the merit of Euclid, the state of geometry before him should be considered. Proclus gives the improbable legend that the Egyptians were obliged to invent geometry in order to find again the boundaries of their fields, effaced by the inundations of the Nile. Thence it was brought to Greece by Thales, but it was first raised to a liberal science, and applied to the solution of speculative and theoretical problems, by Pythagoras. Hippocrates was the first to write on elements. Plato, without writing particularly upon geometry, contributed much to its progress by his use of the analytic method, and by the mathematical style of his books; and new theorems were added by numerous lesser philosophers. At the advent of Euclid something had been written on proportion, incommensurables, loci, solids, and perhaps conic sections; and the important property of the right-angled triangle had been discovered. It was the glory of Euclid to unite in a single book all the discoveries of his predecessors, and to add several new ones of his own. He surpassed all other geometers of antiquity in the clear exposition of his theorems and the rigid order of his demonstrations. The "Elements" of Euclid belong both to geometry and arithmetic. They consist of 13 books written by Euclid, and two others written probably by Hypsicles; and they may be divided into four parts, of which the first, comprising the first six books, treats of the properties of plane figures, and presents the theory of proportions; the second gives, in the three following books, the general properties of numbers; the third, consisting of the tenth book, is the development of all the power of the preceding ones, and is occupied with a curious and profound theory of incommensurable quantities; and the remaining books are on the elements of solid geometry, and were so much studied among the Platonists as to receive the name of the Platonic. The best

known of the treatises of Euclid, after the "Elements," is the "Data." By this name are designated certain known quantities which by means of analysis lead to the discovery of other quantities before unknown. One hundred propositions are here collected which are the most curious examples of geometrical analysis among the ancients. Newton highly valued them, and Montucla styles them the first step toward transcendental geometry.—The history of the works of Euclid is the history of geometry itself, both in Christian and Mohammedan countries, until after the revival of learning. They were commented upon by Theon and Proclus, and became the foundation of mathematical instruction in the school of Alexandria. Of the numerous editions and commentaries among the Orientals, that of Nasir ed-Din, a Persian astronomer of the 13th century, was the best. The "Elements" were restored to Europe by translation from the Arabic, the first European who translated them being Adelard of Bath, who was alive in 1130, and who found his original among the Moors of Spain. Campanus, under whose name this translation was printed, was for a long time thought to be its author. The Greek text was first published in 1533 by Simon Gryneus at Basel, and in subsequent editions was corrected by comparison of manuscripts. Since then the work has been published in a great variety of editions, and translated into all the European and many oriental languages. The English adaptations by Simon and Playfair have been widely received as text books in geometry.

**EUCLID OF MEGARA**, a Greek philosopher, born about 440 B. C. His first master was Parmenides; afterward he became a devoted disciple of Socrates, at whose death, according to Plato, he was present. But notwithstanding his affection for his second teacher, he retained from the Eleatic school an invincible tendency to subtlety, and it was said of him by Socrates that he knew how to live with sophists, but not with men. After the death of Socrates, his disciples, fearing for their lives, fled from Athens; and at Megara, in the house of Euclid, they found an asylum and a new centre for their studies. Plato himself was an ardent attendant upon Euclid, who taught that the essence of good was unity, unity so entire as to embrace immobility, identity, and permanence. Hence the sensible world has no moral character and no relation to good. He taught also that being consists only in unity, identity, and permanence, and hence the sensible world has no part in existence. Being and good are thus the same thing, namely, unity; good therefore alone exists, and evil is but the absence of existence. It does not follow, however, that there is but a single being and a single sort of good, for unity may be found contained in various things. Euclid expressly taught that in spite of their unity, being and good clothe themselves in

different forms, present themselves under different points of view, and receive different names, as wisdom, God, intelligence, and others. Euclid also anticipated Aristotle in distinguishing the act from the power, and resolved according to his ideas of being the relation between the two.

**EUDIOMETER** (Gr. *εἰδία*, pure air, and *μέτρον*, measure), an instrument invented by Priestley for determining the proportion of oxygen in the air, in the belief that on this depended its salubrity. Many other instruments have since been invented for estimating the amount of oxygen in gaseous mixtures, and the name is retained for these, though it has no longer its original significance. In the application of the instrument for estimating oxygen, the gas is made to unite with some substance, as phosphorus, introduced into the gaseous mixture, which is contained in the upper end of a graduated glass tube inverted over mercury. The diminution of bulk caused by the absorption of the oxygen indicates its quantity. In other forms a known quantity of hydrogen is introduced, and a mixture fired by an electric spark produced by means of two wires being melted into the sides of the tube and nearly meeting each other within. In this case the tube is made very thick to withstand the explosion. Every two volumes of hydrogen consume one of oxygen, whence the quantity of the latter may be estimated.

**EUDOCIA**. I. A Roman empress, born in Athens about A. D. 394, died in Jerusalem about 461. She was instructed by her father, the sophist Leontinus, in the religion, literature, and science of the pagan Greeks, and was as remarkable for beauty as for learning. Leontinus at his death left her only 100 pieces of gold, saying that the merits of his daughter, which raised her so much above her sex, would be sufficient for her. Having sought in vain from her brothers a share in the paternal heritage, she went with an aunt to Constantinople to solicit the cancelling of the will. She procured an audience of Pulcheria, sister of the young emperor Theodosius II., and regent in his name, who was so charmed by her wit and beauty that she induced her brother to marry her in 421, after her baptism, when she received the name of Eudocia in place of her original one of Athenais. She received the title of Augusta in 423, and requited the unkindness of her brothers by making them consuls and prefects. During the first 20 years after her marriage she took little part in public affairs, which remained in the hands of Pulcheria. She translated parts of the Old Testament into hexameter verses, and a life of Jesus Christ composed in verses taken from Homer is attributed to her. She also celebrated in verse the Persian victories of Theodosius, and the legends and martyrdom of St. Cyprian. She at length, supplanting Pulcheria, ruled the empire for several years. Her court was filled with learned men, with one



of whom, Paulinus, a companion of her early studies in Athens, she cherished an intimacy which roused the jealousy of her husband, and Paulinus was banished to Cappadocia, where he was soon afterward assassinated. The Eutychiean discussion was at this time vexing the church; Pulcheria and Eudocia adopted different views, and in the alternate ascendancy of the two parties, first the former and then the latter was exiled. Eudocia retired to Jerusalem, where the jealousy of the emperor or the vindictive spirit of Pulcheria pursued her, and two priests who shared her exile were slain. The exasperated empress immediately put to death the agent of the emperor; and being now stripped of all the honors of her rank, she passed the remainder of her life in exercises of piety and charity.

**II.** A Byzantine empress, wife of the emperors Constantine XI. (Ducas) and Romanus IV. (Diogenes). She was married to Constantine before his accession in 1059, receiving the title of Augusta. On his death in 1067 he bequeathed the empire to her and her three sons, binding her by an oath not to marry again. Romanus Diogenes, a popular and able soldier, prepared to seize the throne. Eudocia imprisoned and exiled him, but subsequently married him and made him her colleague. They differed, however, and she again imprisoned him, and during his captivity Joannes Ducas, brother of Constantine, who had been made Cæsar, declared Michael Parapinaces sole emperor, and banished Eudocia to a convent near the Propontis. Her husband died from cruel treatment in 1071, and she buried him with great splendor. She appears to have lived many years after this. She compiled a dictionary of history and mythology, entitled *Ἰστορίαι* (a "Collection of Violets," printed in the *Anecdota Græca*, Venice, 1781).

**EUDOXIA**, empress of the West, daughter of Theodosius II. and Eudocia, born in Constantinople in 422, died about 463. She was married to her cousin Valentinian III., emperor of the West, after whose death by the hands of emissaries of the senator Maximus for having outraged his wife, she was constrained to espouse the latter. Maximus subsequently had the folly to reveal to her the part which he had taken in the murder of Valentinian, and when the time for vengeance seemed to her to have come she invited to Italy Genseric, king of the Vandals, at whose approach Maximus was murdered. Genseric delivered Rome to pillage, and bore away with him to Africa Eudoxia and her two daughters. They were released after a detention of some years, during which one of the daughters was forced to marry the son of Genseric.

**EUDOXUS OF CNIDUS**, a Greek natural philosopher, born about 409 B. C., died about 356. He studied under Archytas and Plato, travelled in Egypt, and returned to Cnidus in 359, founded a school, and built an astronomical observatory. Though he seems to have treated the

whole circle of the sciences, he particularly excelled in geometry and astronomy, and is called by Cicero the prince of astronomers. In his astronomical system the earth was the motionless centre of all the celestial revolutions. The movements of the sun, moon, and five planets resulted, according to him, from the combined revolutions of concentric spheres, of which there were three each for the sun and moon, and four for each of the planets. Every planet occupied a part of the heavens by itself, and was surrounded by moving spheres, whose mutually modified motions made the orbit of the planet. He first fixed the length of the year as adopted in the Julian calendar at 365½ days, and introduced celestial spheres or globes. In music he studied the numerical relations of sound according to the rapidity of the vibration of the chords. In arithmetic he added three kinds of proportion to the three kinds known before him.

**EUDOXUS OF CYZICUS**, a Greek navigator of the latter half of the 2d century B. C. Expeditions from Egypt to India had for a time ceased, when he revived them under the reign of Ptolemy Physcon. His bold enterprise in seeking the most direct route to India, to which he made two voyages, and whence he seems to have been the first to bring diamonds, and in attempting to circumnavigate Africa by the west, caused him many persecutions; and his reputation has been obscured by the fables with which Mela and others sought to embellish it.

**EUFULA**, a city of Barbour co., Alabama, on the right bank of the Chattahoochee river, at the terminus of the Montgomery and Eufula railroad, and a branch of the Southwestern railroad of Georgia, 80 m. S. E. of Montgomery; pop. in 1870, 3,185, of whom 1,640 were colored. It stands on a high bluff, 200 ft. above the water, and contains several churches and newspaper offices, and many stores. An active trade is carried on by means of the river, which is navigable to this point from November to June. It is the principal shipping point for the produce of the surrounding plantations, and exports cotton.

**EUGENE** (FRANÇOIS EUGÈNE DE SAVOIE-CARIGNAN), prince, a general in the service of the house of Austria, born in Paris, Oct. 18, 1663, died in Vienna, April 21, 1736. He was the youngest of the five sons of Prince Eugène Maurice of Savoie-Carignan, count of Soissons, and Olympia Mancini, a niece of Cardinal Mazarin, who was conspicuous for her intrigues at the court of Louis XIV. It was intended by his parents that Eugene should enter the priesthood; but this was against his wish, and he neglected all clerical studies and devoted himself to military reading. Indignant at an attempt of the king to force him into the church, and angry at the treatment to which his mother was subjected by her enemies with the tacit consent of Louis, Eugene left France in 1683, declaring that he would never thereafter enter French territory save as

an enemy. He entered the Austrian service, and made his first campaign against the Turks the same year, so distinguishing himself that he was placed in command of a dragoon regiment. He was present at the battle of Vienna. Further service led to further promotion, and he held the rank of major general at the siege of Belgrade in 1688, where he was severely wounded. Louvois now required all Frenchmen serving in foreign armies to return home, on pain of banishment. Eugene refused to obey, and declaring that he would return to France in spite of the minister, remained in the imperial service, and was rapidly promoted. He was sent to Savoy in command of the Austrian troops furnished to the duke of that country to aid him against France. In this service he fought in several campaigns, and fulfilled the boast he had made at the time of Louvois's order, by invading France with the duke in 1692. He was breveted field marshal, and after his return to Vienna in 1696 was placed at the head of the army in Hungary. Sensible of the folly he had committed, Louis XIV. now made him great offers on condition of his entering the French service. These offers he would not listen to, but took command of an army that was employed against the Turks. He completely outgeneraled the enemy and exterminated their army at Zenta, Sept. 11, 1697, winning one of the greatest victories of that age. A story that the action was fought in violation of orders, that he was afterward placed under arrest, and that it was intended to send him before a council of war, was long current, and has generally been given by all but the more recent historians and biographers; but it has now been proved to be entirely false. He accomplished nothing more of importance in this campaign, and peace was made at Carlovitz in 1699. When the war of the Spanish succession opened in 1701, Eugene was sent to Italy, whither he led his troops by a skilful march across the Tyrolese Alps. Opposed to Catinat, he won great successes. Villeroi, Catinat's successor, he defeated at Chiari, and compelled him to abandon the territory of Mantua. In January, 1702, he attacked the French in Cremona, and, though repulsed, captured their general. In Vendôme he found a worthy antagonist, and they fought the bloody drawn battle at Luzzara, Aug. 15, 1702. Appointed president of the war council, and afterward sent against the Hungarians, Eugene's next important command was in southern Germany, whither he was sent to oppose the united Bavarian and French armies threatening Austria from that direction. Here he first served in company with Marlborough. They fought and won the battle of Blenheim, Aug. 13, 1704, Eugene's part in the action being important. He was then sent again to Italy, and was defeated at Cassano by Vendôme, Aug. 16, 1705, being twice wounded. When the French army passed into the hands of the duke of Orleans and Marshal Marsin, and they

were engaged in besieging Turin, Eugene, at the head of only 30,000 men, attacked their 80,000 men, and defeated them, Sept. 7, 1706. He was wounded in the action, and was rewarded with the government of the Milanese. The next year he again led an army into the south of France, and made an attempt upon Toulon, but failed. He was then employed at the German court in hastening preparations for the next campaign in the Netherlands, now the scene of the chief events of the war, and in that campaign (1708) he helped Marlborough to win the battle of Oudenarde, and took Lille. He also won with him the battle of Malplaquet, Sept. 11, 1709. Much of the ground gained by these victories was lost through the subsequent lukewarmness of the English. On the decline of Marlborough's power in 1711, Eugene visited England, hoping to gain her back to her former position in the alliance, but ineffectually. The peace of Utrecht was concluded in 1713. His own exertions against the French were fruitless, and in 1714 the peace of Rastadt, in negotiating which he played a principal part, put an end to the war between the empire and France. After residing at Vienna for some time, where he was much consulted by the emperor, he was appointed to the command of the army sent against the Turks. He defeated them at Peterwardein, Aug. 5, 1716, with immense slaughter. The next year he advanced against Belgrade, and was there assailed by very superior forces; but at a time when his destruction was regarded as inevitable he assailed the enemy, inflicted upon them the greatest defeat they ever experienced, Aug. 16, and two days later the city surrendered. He was wounded in the battle. In 1718 he hoped to dictate peace at Constantinople, but the treaty of Passarowitz stopped his career of conquest. He was rewarded by a pension, an estate worth 300,000 florins per annum, and the vicar-generalship of Italy, having previously occupied the office of governor of the Netherlands. He held for many years nearly the same position in Austria that Wellington subsequently held in England. Yet he had bitter enemies, toward whom he was very forbearing and patient. In many of his political opinions he was in advance of his age. He saw the error of the house of Austria in encouraging the growth of Prussia, and in conferring on her chief the royal title. He favored an alliance with France, thus anticipating the policy of Kaunitz. He fostered literature, science, and art, and corresponded with Boerhaave, Montesquien, and Leibnitz, the last named being his personal friend; and he made great collections of MSS., books, and pictures. The last military service in which he was engaged was that which grew out of the war of the Polish succession, in 1734, when he commanded an army against the French on the Rhine. There was not much fighting and no pitched battle. The heir apparent to the Prussian crown, afterward Frederick II., then served under him, and the first

hostile cannon he ever heard, at Philippsburg, were the last heard by Eugene. Frederick pronounced his commander to be only "the shadow of the great Eugene." Nearly two years later Eugene was found dead in his bed one morning, after having played piquet the previous evening. His funeral was one of the most magnificent ever known, 16 field marshals carrying the coffin, and the emperor attending as a private mourner. He was never married.

**EUGÉNIE**, empress of France. See **BONA-PARTE**, vol. iii., p. 55.

**EUGENIUS**, the name of four popes. **I. Saint**, born in Rome, died there, June 2, 657. After the banishment of Martin I. in 653, Eugenius was chosen to govern the church as vicar general, and in September, 654, pope, with the consent of Martin, who died in the following year. He labored in vain, like his predecessor, to end the Monothelite controversy. **II.** Born in Rome, died there, Aug. 27, 827. His election, in February, 824, gave rise to a schism that was quelled by the arrival in Rome of Lothaire, son of Louis le Débonnaire. This prince, conjointly with the pope, purified the administration of justice, and corrected many inveterate abuses. A council was convened for the reform of church discipline, which, among other enactments, enjoined on all who had charge of souls to expound the Scriptures to the people and instruct them in all their Christian duties. Eugenius also adopted wise measures for preventing scarcity of food and providing for the sick and poor, whence he was called "father of the people." Some writers have affirmed that he approved of the ordeal by water. **III. Bernardo Paganelli**, born in Montemago, near Pisa, about 1100, died in Tivoli, July 8, 1153. He belonged at first to the order of Cluny, became afterward a follower of St. Bernard, and was by him appointed abbot of the Cistercian monastery of the Three Fountains in Rome. On his accession to the papacy, in February, 1145, he found Rome under the government of a senate, with a president bearing the title of *patricius*. Lucius II. had been killed while attempting to put down a revolt; and Eugenius, unwilling to sanction the new order of things, left Rome, called on the Tiburtines for aid, and restored for a time his own authority. He then proceeded to France and Germany for the purpose of organizing the second crusade; held councils in Paris, Rheims, and Treves; visited Clairvaux, where he had been a monk; and in 1149 returned to Italy. The Romans, who during his absence had again established a republic, were forced to submit to the pope through fear of the king of Sicily. Eugenius reentered Rome, but was driven out after a short time, and spent the remainder of his life in Tivoli. The present division of Ireland into four ecclesiastical provinces is due to this pontiff. It was by his direction that Gratian published the body of canon law called *Decretum*; and at Gratian's suggestion he instituted the academic degrees of bachelor,

licentiate or master, and doctor, to which he attached many privileges. **IV. Gabriele Condulmero**, or **de' Condulmeri**, born in Venice in 1383, died in Rome, Feb. 23, 1447. His mother was sister to Gregory XII. Gabriele after his father's death distributed 25,000 ducats among the poor, and became a canon in the Celestine congregation of San Giorgio in Alga. On the elevation of Gregory XII. he was induced to go to Rome, where his uncle made him successively chamberlain, bishop of Siena, and cardinal. Martin V. employed him in many important offices, and made him legate (governor) of the marches and Bologna. He was elected pope on the very day appointed by his predecessor for the opening of the œcumenical council of Basel, March 3, 1431. The counsels of the Orsini faction immediately involved him in a quarrel with their hereditary rivals, the Colonnas, the family of Martin V. The civil war which ensued was quelled for a time by the interposition of the emperor Sigismund, and the active support of the Florentines and Venetians. This led him to form an alliance with Venice and Florence against Filippo Maria Visconti, duke of Milan, and his father-in-law Alfonso the Wise of Aragon, both of whom thus became almost his lifelong enemies. The Colonnas, though reduced to temporary submission, were powerfully aided by the Visconti; and their attacks and intrigues were followed up so perseveringly, that the Romans rose against Eugenius in 1434, and compelled him to fly in disguise to Florence. The council of Basel had been convened primarily for the double purpose of reforming the western clergy and healing the Hussite schism, and secondarily for bringing about a reconciliation with the eastern churches. The emperor Sigismund, with all the western princes and prelates, considered the former object as the only one of urgent importance, and approved of Basel for the meeting of the council. The pope, the Greek emperor and his prelates, and the Italian bishops were chiefly anxious for the reunion of the churches, and desired that the council should be held in an Italian city. The small number of prelates present in Basel throughout the year 1431, and some erroneous information given to the pope by a messenger from the council, induced him on Nov. 12 to write to Cardinal Cesarini, the president of the council, ordering him to dissolve it, and to proclaim the indiction of a new council in Bologna for 1433. Cesarini, who had just returned (October, 1431) from Bohemia, where he had witnessed the disgraceful rout of 100,000 imperial troops by Procopius and his Hussites, remonstrated energetically. The council and the emperor had at his suggestion sent a pressing invitation to the Hussite leaders to come to Basel. The change ordered by the pope would destroy the last hope of ending the dreadful religious war which now threatened to devastate all Germany. This opposition of Cesarini was shared by the emperor, by all the western

princes, and particularly by the king of Aragon and the duke of Milan. The members of the council therefore proceeded to act at first independently of the pope, and soon after against his authority and person. (See **BASEL, COUNCIL OF.**) The efforts of Sigismund, who was crowned in Rome in August, 1433, brought about a momentary peace between pope and council; but the revolutionary measures of the latter compelled the pope to dissolve it in June, 1437. An œcumenical council was opened in Ferrara Jan. 10, 1438; on Jan. 27 the pope arrived to preside in person, and early in February the Greek emperor, John Palæologus, and a large number of Greek bishops, arrived in Ferrara, after having been magnificently entertained in Venice. The plague soon breaking out, the pontiff transferred the council to Florence, where on July 6, 1439, was published the decree of union of the Greek and Latin churches. (See **FLORENCE, COUNCIL OF.**) The Armenians, Jacobites, and other eastern communions sent in their adhesion subsequently, either before the end of this council or during that held in Rome in 1444. Meanwhile the refractory prelates of Basel had elected an antipope in the person of Amadeus of Savoy. In 1435 Joanna II. of Naples bequeathed her crown to René of Anjou; but the king of Aragon claimed it as his rightful inheritance, and supported his claim by a powerful armament. The pope, who was the acknowledged suzerain of Naples, rejected both pretenders, and a calamitous war followed between him and Alfonso. It ended by the pope's granting the investiture of the kingdom to Alfonso, and by the latter's aiding the pope to repel the attacks of his own domestic enemies. The pope was thus enabled to reënter Rome Oct. 28, 1443, after nine years' absence; and he immediately convened a new council to meet in St. John Lateran in 1444. A new storm had been threatening Eugenius from the side of Germany. The bishops of Cologne and Treves had been excommunicated and deposed by him for their adherence to the antipope. As they enjoyed the rank of prince-electors of the empire, the whole electoral body took up their quarrel, which was also espoused by the emperor and all the German princes. They had taken at first a position of neutrality between Eugenius and the antipope; but the persistent refusal of the former to revoke his sentence of deposition brought on a threat of recognizing Felix V. as the lawful pope. At length, through the good offices of Æneas Sylvius Piccolomini, afterward pope as Pius II., the difficulty was settled, and all Germany declared formally against the antipope (1447). One of the great anxieties of Eugenius had been the steady progress westward of the Mohammedan power. The letters of the pontiff and the earnest exhortations of his legate Cesarini had induced Ladislas, the young king of Poland and Hungary, to take up arms against the Turks in 1440. The victories of Hunyady at length

forced them to conclude a peace for ten years, and the treaty had been solemnly sworn to on the Gospel and Koran. The pope, however, refused to accept the peace, on the pretext that it had been concluded without his knowledge; a new war was begun, which ended on the field of Varna (1444), where Ladislas perished with 10,000 of his followers. Eugenius declared this disaster to be the bitterest affliction in his troublous life. In 1447, simultaneously with the settlement of the German difficulty, a plan was submitted to the pope by the French king for ending the schism in the church. This was accepted, and caused unbounded joy, in the midst of which Eugenius sickened and died. He has been reproached with his monkish austerity of life, with rashness and inconstancy in many things, and inflexible obstinacy in others. Those most opposed to him allowed him, nevertheless, the praise of an unblemished life. He was, without being learned himself, a most generous patron of learning.

**EULER, Leonhard**, a Swiss mathematician, born in Basel, April 15, 1707, died in St. Petersburg, Sept. 7, 1783. He was intended for the church, and entered the university of Basel; but the influence of the Bernoullis diverted his attention to philosophical pursuits. At the age of 19 he graduated, after having already attracted the notice of the French academy of sciences by a memoir upon some points of naval architecture. In the following year he went to St. Petersburg, where after several disappointments Daniel Bernoulli obtained for him the professorship of natural philosophy; and in 1733 he became professor of mathematics. His publications on the nature and propagation of sound, curves, the integral calculus, the movement of celestial bodies, &c., had gained him wide reputation; and in 1741, at the invitation of Frederick the Great, he left St. Petersburg for Berlin, where he remained 25 years. During this time he continued to hold his Russian appointments, and even drew a portion of their salary, receiving at the same time from all parts of Europe the most flattering marks of respect. When the dominions of Frederick were invaded by a Russian army in 1760, and a farm belonging to Euler was laid waste, the empress Elizabeth immediately reimbursed his losses. These generous acts, among other motives, induced him to accept an invitation from the empress Catharine II. to return to St. Petersburg in 1766. He had during some years previously suffered from weakness of the eyes; and soon after returning to Russia he became so nearly blind as to be able only to distinguish very large chalk marks on a blackboard. The affection was the consequence of fever brought on by a calculation, for which his fellow academicians demanded four months, but which Euler completed in three days. He continued almost blind during the remainder of his life; but by constant exercise he acquired a power of recollection of mathematical formulas and figures almost incredible. Some of his most

valuable works were composed after his loss of sight; among them, his "Elements of Algebra" and "New Theory of the Motions of the Moon." In more than 50 years of incessant labor he composed 30 separate works, chiefly in Latin, and more than 700 memoirs or treatises. The whole could not be contained in less than 40 large 4to volumes, and embrace every existing branch of mathematics, and almost every conceivable application of them. To Euler belongs the credit of improving the analytic method, according to the system of Leibnitz and the Bernoullis, and of uniformly applying it to scientific investigations. Nor was he less remarkable for his popular expositions of the principles of his favorite science. His "Letters to a German Princess," which have been translated into English, and several times reprinted, throw a clear light on the most important facts in mechanics, optics, acoustics, and physical astronomy, and, though to some degree superseded by the progress of modern discovery, will always remain a model of perspicuous statement and felicitous illustration. His "Introduction to Algebra," translated by Prof. Farrar of Harvard college as preliminary to the Cambridge course of mathematics, has never been surpassed for its lucid and attractive mode of presenting the elements of that science. Euler was a man of simple, reserved, and benevolent mind, with a strong devotional sense and religious habit. He undertook to prove the immateriality of the soul, and had the courage to defend revelation at the court of Frederick II. He was twice married, his second wife being the aunt of his first, and had 13 children, only four of whom survived him. The eldest son was his assistant and successor at St. Petersburg, and the second was physician to Catharine II.

**EUMENES**, a general of Alexander the Great, and one of his successors, born at Cardia, in the Thracian Chersonese, about 360 B. C., put to death in Gabiene, Elymais, in 316. He attracted the notice of Philip of Macedon, who made him his private secretary, and he held the same office under Alexander. When Alexander married the daughter of Darius, he gave to Eumenes Artonis, daughter of Artabanus. He was at enmity with Alexander's friend Hephæstion, yet maintained his influence, and was ultimately appointed a commander of the cavalry. After the death of Alexander, he at first took no part in the discussions of the Macedonian generals, knowing their jealousy of his Greek birth; but subsequently he reconciled the opposing parties, and in the division of the satrapies obtained the government of Cappadocia, Paphlagonia, and Pontus. These provinces had never been conquered, and Antigonus and Leonnatus were appointed to reduce them for him. Antigonus disdained compliance, and Leonnatus went to Greece to carry out plans of personal ambition, having tried to persuade Eumenes to join with him. Eumenes, however, exposed the

schemes of Leonnatus to Perdicas, and the latter subdued his provinces for him, and gave him the chief command in Asia. Eumenes now subdued Neoptolemus, who had revolted from him, and defended Asia Minor against Craterus in a decisive battle (321), in which the latter fell. Perdicas having fallen in a revolt of his own troops, a general assembly of the Macedonian army condemned Eumenes to death. Antigonus marched against him, defeated him in Cappadocia (320), and blockaded him in the fortress of Nora. The death of Antipater changed the aspect of parties; and Antigonus sought the alliance of Eumenes; but the latter, having been allowed to leave his mountain fortress, accepted overtures offering him by royal authority the supreme command in Asia. Eluding Antigonus, he joined the army in Cilicia, and to avoid the jealousy of the generals set up in a tent the throne, crown, and sceptre of Alexander, before which the councils of war were held, as though in the presence of the deceased monarch. He advanced into Phœnicia, but retired before the combined fleet and army of Antigonus, and took up winter quarters in Babylonia. The armies subsequently met on the confines of Gabiene in two pitched battles, with no decisive result; but Eumenes was sold by his own troops to Antigonus, who slew him.

**EUMENIDES** (called also Erinnyes, and by the Romans Furisæ and Diræ), the avenging goddesses of the Greek mythology, daughters of Night, and tormentors of the wicked both in the upper and the lower world. The Greeks dreaded to call them by an appropriate name, and therefore addressed them euphemistically as the Eumenides, or gracious goddesses. They seem to have been originally a personification of the curses pronounced upon a criminal, and are represented by Homer as resting in the depths of Tartarus till the condemnation of some person for violated pious or hospitable duties wakes them into life and activity. They then pursue the offender with the relentlessness of fate, chasing him from place to place, allowing him no peace nor rest, moved by no supplications, and supported by the goddess of justice, whose ministers they are. As described by Æschylus, snakes instead of hair enveloped their heads, their eyes were bloody, their faces black and full of hatefulness, and they bore torches and daggers in their fleshless hands. In the later poets wings were added, and their number was reduced from an indefinite number to three, bearing the names of Tisiphone, Alecto, and Megæra. The terrific drama of Æschylus entitled "Eumenides" is said to have frightened several Athenian matrons into premature labor, and in subsequent representations upon the stage and in art their appearance was greatly softened down.

**EUNAPIUS**, a Greek sophist, physician, and biographer, born in Sardis, Lydia, A. D. 347, died about 420. He was an adversary of Christianity, and an enthusiastic admirer of the em-

peror Julian. At the age of 16 years he went to Athens, where after four years' study he was admitted to know the secrets of the theurgic doctrine of Iamblichus, and was initiated into the Eleusinian mysteries. He returned to Sardis as a teacher of rhetoric, and studied medicine. One of his works remains, a book entitled "Lives of the Sophists and Philosophers," which gives the history of philosophers, physicians, and rhetoricians, and of nearly all known in science and letters from the beginning of the 3d to the end of the 4th century. The best edition is that of Boissonade (2 vols. 8vo, Amsterdam, 1822).

**EUNOMIUS**, a heresiarch of the 4th century, a native of Dacora in Cappadocia, who studied theology under the Arian teacher Aëtius, and was made bishop of Cyzicus about 360. His opinions were a logical exaggeration of Arianism. He was soon deposed from his bishopric, resided at Constantinople during the reigns of Julian and Jovian, and at Chalcedon during that of Valens; was banished by the last named, but soon recalled; was again banished by Theodosius the Great to Ilalmyris in Mæsia, driven thence to Cæsarea, and at length permitted to return to his native village, where he spent the remainder of his life, and died at an advanced age. His works were ordered by imperial edicts to be destroyed, but there remain of them a "Confession of Faith," which was presented to the emperor Theodosius at Constantinople in 383, and an "Apologetic Discourse," a famous treatise, of which St. Basil wrote a refutation in five books. His disciples were called Eunomians, and also Anomæans (Gr. *ἀνομοιοι*, dissimilar), because, unlike the Athanasians or Homoousians and the Arians or Homoiousians, they affirmed that the Son and Holy Spirit were neither identical with nor similar in essence to the Father. They acknowledged the Father as supreme, eternal, and distinct; the Son as generated from the Father, and the Holy Spirit as generated from the Son. Like their founder, they were accustomed to subtle speculations upon the divine nature, the incomprehensibility of which they denied. They rejected mysteries, and opposed the honors rendered to martyrs and to the relics of saints.

**EUNUCHS** (Gr. *εὐνοῦχος*, from *εὐνή*, a bed, and *ἔχειν*, to guard), emasculated men employed in the East from time immemorial to take charge of women. A product of oriental polygamy, jealousy, and despotism, eunuchs were early common in Egypt, Syria, Asia Minor, and the neighboring countries, and were introduced thence into Greece and Rome. Among the later Romans they were admitted into the families of senators and emperors, and by their skill in flattery and intrigue often established their power at court, especially under the Byzantine empire. The Romans ingeniously devised a method of making castration more or less complete. Gibbon affirms that the general history of Persia, India, and

China proves that the power of the eunuchs has uniformly marked the decline and fall of every dynasty. They are still employed in the East as guardians of the harem, black slaves from Africa being generally preferred. The eunuchs of the Turkish harems are mostly made such in Upper Egypt, near Nubia, at a village where the operation of castration is performed by Coptic priests. It is stated that about one in seven of the boys die in consequence of the operation.—The Christian church from the beginning manifested her abhorrence of the practice of mutilating men, excluding eunuchs from orders even before a law to that effect had been promulgated. The ordination of Origen at an advanced age, by the bishops of Cæsarea and Jerusalem, was protested against by his own bishop, Demetrius of Alexandria, on the ground that Origen in his youth had mutilated himself as a safeguard against temptation—a fact which Origen had concealed, but which had become known to Demetrius. This recognition of such an ordination as irregular attested the universal discipline of the church, confirmed by the law enacted by the council of Nice, and observed ever since throughout Christendom. This law was directed more especially at a sect of fanatics called Valesians, from their Arab founder Valesius, who insisted upon this practice of mutilation as a necessary means of salvation. Christian Italy inherited from pagan times the custom of mutilating boys in order to preserve their voice; and down to our days such singers have been much sought for in theatres and churches. Clement XIV., renewing the enactments of several preceding popes, forbade their employment in religious services. Nevertheless, the custom still continued to prevail in Rome itself. (See CASTRATION.)

**EUPATORIA** (formerly *Kozlov*), a seaport town of Russia, in the government of Taurida, on the W. coast of the Crimea, and on the N. shore of the bay of Kalamita, 38 m. N. W. of Simferopol, and 40 m. N. of Sebastopol; pop. in 1867, 7,730, chiefly Tartars and Carait Jews. Under the Tartars it was one of the most prosperous and populous towns in the Crimea. Before the Russian occupation of the peninsula, when the name of Eupatoria was given to the town by Catharine II., it had a population of above 30,000. It has a considerable trade in grain, and some trade in hides, butter, wax, &c. The export of salt, which is drawn from adjoining salt lakes, and from which the Tartars formerly derived great profit, has fallen off considerably. Butter, felt stuffs, and the black lambskins known in England as astrakhans, are prepared in the town. The port is shallow, but safe, and never frozen up. The principal buildings are a Greek church, an Armenian church, two synagogues, and several mosques, the chief of which, built by Devlet-Ghiri Khan in 1552, is the finest in the Crimea.—On Sept. 14, 1854, the English and French effected a landing in the bay of Eupatoria, with about 60,000 men.

The town was provided with fortifications by order of Omar Pasha, who was at the head of the Turkish troops in 1855. The Russians made an ineffectual attack on it Feb. 17, 1855. It was evacuated by the allies after the ratification of the peace of Paris, May 30, 1856.

**EUPATORIUM.** See **BONASET.**

**EUPEU** (Fr. *Néau*), a town of Prussia, in the province of the Rhine, capital of a circle of the same name, situated near the Belgian frontier, 9 m. S. of Aix-la-Chapelle; pop. in 1871, 14,696. It has a Protestant and three Catholic churches, a town school of a high grade, an orphan asylum, and a court of primary jurisdiction. It is one of the most flourishing manufacturing towns of the province.

**EUPHORBIA**, the typical genus of the botanical family *euphorbiaceæ*, or spurges, said to have been so named from Euphorbus, physician to Juba, king of Mauritania. The flowers are monœcious, collected within an involucre often closely simulating a calyx or corolla; male flowers consisting of a single stamen on a pedicel arising from the axil of a minute bract at the base of the involucre; fertile flower solitary in the middle of the involucre, consisting of a three-celled, three-lobed ovary, with a mere vestige of calyx, and borne on a pedicel which finally elongates and inclines to one side of the involucre; styles three, stigmas six. The pod separates into three one-seeded carpels. Plants or shrubs, often with a milky, acrid juice. The leaves are whorled or opposite, and sometimes wanting, the stem being succulent, and the plant assuming the appearance of a cactus. It is a cosmopolitan genus of many and diverse species. Some are commonly cultivated as ornamental plants, as *E. pulcherrima* (*Poinsettia*)



*Euphorbia officinarum.*

of Mexico, whose floral leaves are 4 or 5 in. long and of the brightest vermilion red; *E. splendens* of the Mauritius, with thick, prickly stems, and cymes of deep red bract-surrounded flowers. The gum resin, *euphorbium*, is gathered in Africa from *E. officinarum* and *E. an-*

*tiquorum*, and in the Canaries from *E. Canariensis*; it flows from incisions made in the stems, and is extremely acrid, producing violent inflammation of the nostrils in those who handle it. In India this gum is used externally in rheumatism, internally in cases of severe



*Euphorbia ipecacuanha.*

constipation. *E. Tirucalli* is common near Madras, where it is used for hedging; no cattle will touch the leaves; the fresh juice of this species is used as a vesicant. The roots of many species are emetic. Of our native species, the principal and the only one of general interest is *E. ipecacuanha* (wild ipecac), which was considered by Barton equal in value to the genuine ipecacuanha (*cephælis*), and it possesses the advantage of having no disagreeable taste or smell. *E. lathyris* was one of the plants Charlemagne in his capitularies commanded to be cultivated in all monastic gardens, as its seeds were purgative and known as *semina cataputiæ minoris*. It is said that the capsules of this plant stupefy fish; it is well known that *E. Hibernica* and *E. piscatoria* are so used, and so powerful is the former that a small basketful of the bruised plant will stupefy the fishes for several miles down a river. *E. Cattimandu* furnishes a caoutchouc; and notwithstanding the generally poisonous qualities of the genus, *E. edulis* is a pot herb, its acrid qualities being dispelled by boiling. *E. balsamifera* is used in the same way. Many species of euphorbia grow in poor sandy soil, through which the roots penetrate to a depth of several yards. Violent vomiting and purging are often produced in children by eating the seeds of a variegated-leaved euphorbia cultivated as an ornamental plant. The uncertainty of their action forbids their general use as medicine.

**EUPHRATES** (Turk. *Frat*), the largest river of western Asia. It rises from two chief sources in the Armenian mountains; one of them at Dumly, 25 m. N. E. of Erzerum, the other on the northern slope of the Ala Dagh,

near the village of Diyadin, and not far from Mt. Ararat. The former, or Northern Euphrates, has the name of Frat from the first, but is known also as the Kara-su (Black river); the latter, or Southern Euphrates, is not called the Frat, but the Murad Chai, though in reality the main river. Both branches flow mainly W. S. W. and meet at Kieban-Maaden, about lat. 38° 50' N. and lon. 38° 40' E., after a course of respectively 270 and 400 m. The combined stream is here 360 ft. wide, rapid, and very deep. It flows a winding course, mostly S. and S. W., traversing a chain of Mt. Taurus, till it reaches the vicinity of Nizib, where it is deflected S. E., keeps its way without deviation till near its junction with the Tigris, and the united rivers fall, under the name Sbat-el-Arab, into the Persian gulf. Its total length is about 1,800 m., its average breadth about 200 yards, and its depth from 12 to 30 ft. The upper part of its course lies amid lofty mountains, and near the village of Pashtash it plunges through a gorge formed by precipices more than 1,000 ft. in height, and so narrow that it is bridged at the top. It then enters the plains of western and southern Mesopotamia, where the swiftness of its current is diminished, and where in ancient times numerous canals extended from its banks to irrigate the neighboring country. It extricates itself from the marshes of Lemlun just before reaching Korna, the point of its union with the Tigris. It is navigable both below and above the cataracts which it forms in the passes of the Taurus, though numerous islands, shallows, and rapids make its navigation in many places difficult. Its waters are subject to periodical increase from the melting of the snow on the mountains along the upper part of its course, and its inundations were anciently of great advantage to the agriculture of the level districts through which it passes. Under the misrule of the Turks, however, the canals and embankments which regulated the inundations have been neglected.—The Euphrates is linked with the most important events in ancient history. It is mentioned in the Bible as one of the four rivers of the garden of Eden, and is often named the great river. On its banks stood the city of Babylon, which was for ages not only the capital of great empires, but also one of the greatest commercial emporiums of the world. Indian and Egyptian merchandise destined for Babylon was transhipped in the port of Gerha, now Katif, in the Persian gulf, from the large vessels that had made the sea voyage into smaller ones fit for the navigation of the river. Nebuchadnezzar, however, had locks constructed, and dikes raised to contain the waters of the Sbat-el-Arab, which allowed vessels of heavy burden to ascend the Euphrates as far as Babylon. It was for a long time the western boundary of the Parthian and the eastern boundary of the Roman empire. The army of Necho was defeated on its banks by Nebuchadnezzar at

Circesium (Carchemish); Cyrus the Younger and Crassus perished after crossing it, the one at Cunaxa, the other at Carrhæ; Alexander crossed it at Thapsacus; Trajan and Severus descended it in fleets built in upper Mesopotamia. In recent times the English have tried to use it as their path of communication with India. For this purpose an expedition was sent from England under command of Col. Chesney, which in 1836 descended the river from Bir and surveyed 509 m. of its course. The steam navigation of the Euphrates, from its mouth to Bir, has since become of some importance. The electric telegraph line from Bagdad to the Persian gulf, which was opened in 1865, skirts the Euphrates as well as the Tigris. It is a singular fact concerning the Euphrates that several thousand years ago the waters do not seem to have reached the sea at all, but were lost in marshes or consumed by irrigation, which was practised on an immense scale under the Babylonian and Assyrian sovereigns. It is certain that at a much later period the Tigris and Euphrates flowed into the sea by distinct channels. Their junction is supposed to have taken place more than 2,000 years ago.

**EUPHUISM** (Gr. *ειφους*, elegant), an affected style of speech which distinguished the conversation and writings of many of the wits at the court of Queen Elizabeth. The name and the style were derived from the "Euphues, the Anatomy of Wit" (1580), and the "Euphues and his England" (1581), of John Lilly, of which Anthony à Wood said: "Our nation is indebted for a new English in them, which the flower of the youth thereof learned." The style of these once famed books, which became the model of the wits and gallants of the time, and was almost regarded as a test of courtly breeding, was characterized by smoothness and verbal elegance, and chiefly by fantastic similes and illustrations formed by attributing fanciful and fabulous properties to animals, vegetables, and minerals. Supported by fashionable sanction, Lilly was for a time esteemed the rival of Demosthenes and Cicero in "all the partes of rhetoricke, in fitte phrases, in pithy sentences, in gallant tropes, in flowing speech." But the applause was not universal. Euphuism is ridiculed in Marston's comedy of "What You Will" and Ben Jonson's "Cynthia's Revels," and is thought to be referred to in the style of Don Armado in Shakespeare's "Love's Labor's Lost." Sir Walter Scott in his "Monastery" makes Sir Piercie Shafton "parley euphuism."

**EUPOLIS**, one of the six Greek comic poets whom the grammarians of the school of Alexandria judged worthy of a place in their canon, born about 446, died about 411 B. C. He belonged to the old comedy, was a disciple of Cratinus, and composed 17 pieces, seven of which were crowned. He was reputed superior to Aristophanes in elegance, and in bitter and personal jests was the rival of Cratinus. Among the objects of his satire were Alcibia-



des and Socrates, the former of whom, according to one report, exasperated by his attacks, threw him into the sea, where he was drowned. He is also said, with more probability, to have been killed in battle during the Peloponnesian war. The fragments of his plays have been edited by Runkel (Leipsic, 1829), and are contained in Meineke's *Fragmenta Poetarum Comicorum Græcorum* (Berlin, 1839-'47).

**EURE**, a N. department of France, formed by the union of four ancient districts of Normandy, bordering on the departments of Seine-Inférieure (from which it is partly separated by the lower part of the Seine), Oise, Seine-et-Oise, Eure-et-Loir, Orne, and Calvados; area, 2,300 sq. m.; pop. in 1872, 377,874. It has a level surface, naturally divided into six plateaus by the rivers Epte, Andelle, Eure, Iton, Rille, and Charentonne, which flow through it to the Seine; and it presents well cultivated fields and enclosures, fine forests, marshes, and a few hills. The river from which the department has its name flows on the S. E. border, and then mostly parallel with the Seine. Agriculture is carried to a high degree of perfection, and the vine, apple, and pear are objects of special cultivation. Its most celebrated and flourishing cloth manufactories are at Louviers. It has important copper foundries at Romilly, and manufactories of nails, pins, &c. It has considerable commerce, chiefly in its own manufactured and agricultural products. It is divided into the arrondissements of Évreux, Louviers, Pont-Audemer, Bernay, and Les Andelys. Capital, Évreux.

**EURE-ET-LOIR**, a N. department of France, formed from parts of the ancient provinces of Orléanais, Ile-de-France, and Maine, bordering on the departments of Eure, Seine-et-Oise, Loiret, Loir-et-Cher, Sarthe, and Orne, and comprised in the basins of the Seine and the Loire; area, 2,268 sq. m.; pop. in 1872, 282,622. Its general aspect is that of a plain, with slight undulations of hill and valley, and its soil is unsurpassed in fertility by any in France. The river Eure, which rises near the W. border in Orne, flows E. and N. through the northern part, and the Loir rises near the centre and flows S. S. W. to the Loire. The climate is mild, with frequent rains in spring and autumn. There are but small remains of the immense forests which formerly covered its surface. Cereals, the vine, prune, pear, cherry, and apricot are cultivated. It has some cloth manufactories. It is divided into the arrondissements of Chartres, Châteaudun, Dreux, and Nogent-le-Rotrou. Capital, Chartres.

**EURIPIDES**, the last of the illustrious trio of the tragic poets of Athens, born, according to the almost unanimous consent of the ancient authorities, in the island of Salamis, in the 1st year of the 75th Olympiad, 480 B. C., and, as was generally believed, on the very day of the battle of Salamis (Sept. 23). The Parian mar-

ble alone carries back the date of his birth to 485, or the fourth year of the 73d Olympiad. He died in 406. The name Euripides is said to have been bestowed upon him in commemoration of the battle of Artemisium, fought not long before, near the channel of the Euripus. He was the son of an Athenian citizen named Mnesarchus, and his wife Clito, of the deme of Phlya and the tribe Cæropis, or according to others of the deme of Phyle and the tribe Cæneis. His parents had left Athens on the approach of Xerxes and his Persian host. The condition of the family was respectable and perhaps affluent, though Aristophanes, in his comic attacks upon the poet, describes his mother as a seller of herbs. Early trained in athletic exercises, Euripides is said to have gained while still a boy the victory in the Eleusinian and Thesean contests; and at the age of 17 he offered himself at the Olympic games, but was not received. For a time he devoted himself to the art of painting, and some of his performances are said to have been exhibited at Megara. He studied rhetoric under Prodicus, the author of the apologue of the "Choice of Hercules," who visited Athens as ambassador of his native city; physics under Anaxagoras, whose opinions gave a coloring to his poetry; and perhaps philosophy under Protagoras. He became an intimate friend of Socrates, who was 11 years his junior. At length, after trying his hand in other pursuits, his natural turn for tragedy manifested itself. His first piece was written at the age of 18, but there is no evidence that it was brought upon the stage. "Peliades," the first of his plays represented in his own name, was brought out in 455. This is not preserved. Fourteen years later, in 441, he gained for the first time the first tragic prize. Ten years after this, in 431, he gained the first prize with the tetralogy, including "Medea," "Philoctetes," "Dictys," and "Theristæ." In 428 he brought out the "Hippolytus;" in 412 "Andromeda;" and in 408 "Orestes." He appears to have carried off the prize but seldom, if we consider the number of his plays—15 times according to Thomas Magister, or five times as others state; while he is said by some to have written 92, and by others 75 pieces, including the satyric dramas or afterpieces with which the tragic trilogy was usually followed. Soon after the representation of "Orestes," Euripides appears to have accepted the invitation of Archelaus, king of Macedon, to take up his residence at that court. He had already held possession of the Athenian stage for more than 50 years, and had written an extraordinary number of masterpieces, when he went to try the uncertain experiment of residence at a foreign court; but there were some powerful reasons which urged him to this step. The rivalries in his art, and still more the attacks to which he exposed himself by the freedom of his philosophical and religious opinions, proba-

bly embittered his life at Athens. According to tradition, Euripides was not happy in his domestic relations, but the details on this subject seem to rest on no credible authority. He lived but a short time after he went to Macedon. According to tradition, he was torn in pieces by the hounds of the king. During his short residence there he acquired a great ascendancy over Archelaus, who loaded him with gifts and honors. When the news of his death reached Athens, it threw the whole city into mourning. Sophocles, then 90 years old, was so deeply moved that he changed his garments, and required his actors to lay aside their crowns and appear in mourning on the stage. The Athenians requested that his remains might be sent home for burial; but the request was not granted. They, however, erected a cenotaph to the poet, on the road from the Piræus to Athens, and his statue was afterward set up, with those of Æschylus and Sophocles, in the Dionysiac theatre, by Lycurgus the orator, a contemporary of Demosthenes. The inscription on the cenotaph is supposed to have been written by Thucydides the historian.—Of the numerous works of Euripides only 19 entire pieces have come down to our times. Many fragments of other plays exist, and are published in the editions of his works. Of the extant pieces, the genuineness of one, "Rhesus," has been called in question. Seventeen are tragedies, and two, "Cyclops" and "Alcestis," were intended as afterpieces, like the satyric dramas (of which "Cyclops" is indeed the only remaining specimen) in tetralogies. The earliest of all is "Alcestis," which was brought out in 438; the date of "Orestes" is the latest ascertained, 408; but several of his pieces were brought out after his death by his son Euripides. The best editions are those of Beck (Leipsic, 1778-'88), of Matthiæ (Leipsic, 1813-'37), that of Glasgow (1821), Kirchhoff (Berlin, 1855), Nauck (Leipsic, 1857), Donner (Leipsic, 1859), and Fritze (Berlin, 1866-'8). Paley's edition (3 vols., London, 1857-'60) is the most beautiful. The whole works of Euripides have been translated into English verse by Potter (2 vols. 4to, London, 1781-'2; 2 vols. 8vo, Oxford, 1814), and into prose by Buckley in Bohn's "Classical Library."—On the moral, intellectual, and poetical merits of Euripides, there was in ancient times, as there is in modern, a great diversity of opinion. Among his contemporaries, Socrates thought so highly of him that he made it a point to attend the theatre whenever a play of his was to be performed, and the philosopher delighted in his conversation. Aristophanes, on the other hand, pursued him with the keenest ridicule, denouncing him as the corrupter of tragedy and the teacher of immoral doctrines, and contrasting him unfavorably in these respects with Æschylus and Sophocles. In modern times, A. W. von Schlegel and the critics of his school have adopted the representations of Aristophanes as the basis of a disparaging judgment.

Aristotle, while censuring his faulty management in some respects, yet pronounces him the most tragic of poets. Milton's opinion nearly coincided with that of Aristotle. Euripides is censured as a woman-hater, and it is supposed that his distrust of the female sex grew out of his own domestic experience. He, like Socrates, is charged with a want of belief in the gods of his country. In a literary point of view, the principal charges against him are that he lowered the tone of tragedy and weakened its style; that he degraded heroic characters by representing them in beggary and rags, and by these coarse means attempting to work out pathetic effects; that he too often introduced his plays with long and tedious narrative or genealogical prologues; that his choruses frequently have little to do with the subject of the piece; and finally, that he delighted in the representation of criminal and unnatural passions. These statements, though having a germ of fact, are quite too absolutely made. In his style Euripides is not lofty like Æschylus, nor elaborately elegant like Sophocles. In his plots he is not so simple as Æschylus, nor so carefully balanced as Sophocles. But in the study of human passions, in the analysis of the characters of men and women, in tracing actions to their hidden motives through all the labyrinthine windings of pretence or self-deception, he is undoubtedly their superior. In his plays there is more of philosophy, in spite of the occasional sophistry that deforms them; there are more pithy maxims, sententious expressions of metaphysical and ethical truth, and discussions that really evolve important conclusions bearing upon the conduct of private or public life. If we judge by the busts and statues of Euripides that have come down to us in the collections of ancient art, he was a man of capacious brain, of grave countenance, and studious habits.

**EURIPUS**, the narrowest part of the channel separating the island of Eubœa, in the Grecian archipelago, from the coast of Bœotia. Its width, opposite the town of Chalcis, is 200 ft., and its average depth from 7 to 8 ft. In the channel is a rocky islet, on which is a small square castle, partly of Venetian and partly of Turkish construction, connected by bridges with both shores. It is under this double bridge, which was built originally in the 21st year of the Peloponnesian war, that the extraordinary changes of current, noted by both ancient and modern writers, take place. These irregularities of the tide are probably caused by the windings of the gulf N. and S. of the strait. In the middle ages Euripus was corrupted into Egrippo, which afterward became Egrippo-ponte, and finally Negroponte, its more modern appellation. With other important points in Greece it has lately resumed its ancient name.

**EUROPA**, in mythology, according to the Iliad, a daughter of Phœnix, mother of Minos and Rhadamanthus by Zeus, who, disguised as a white bull, bore her upon his back across the

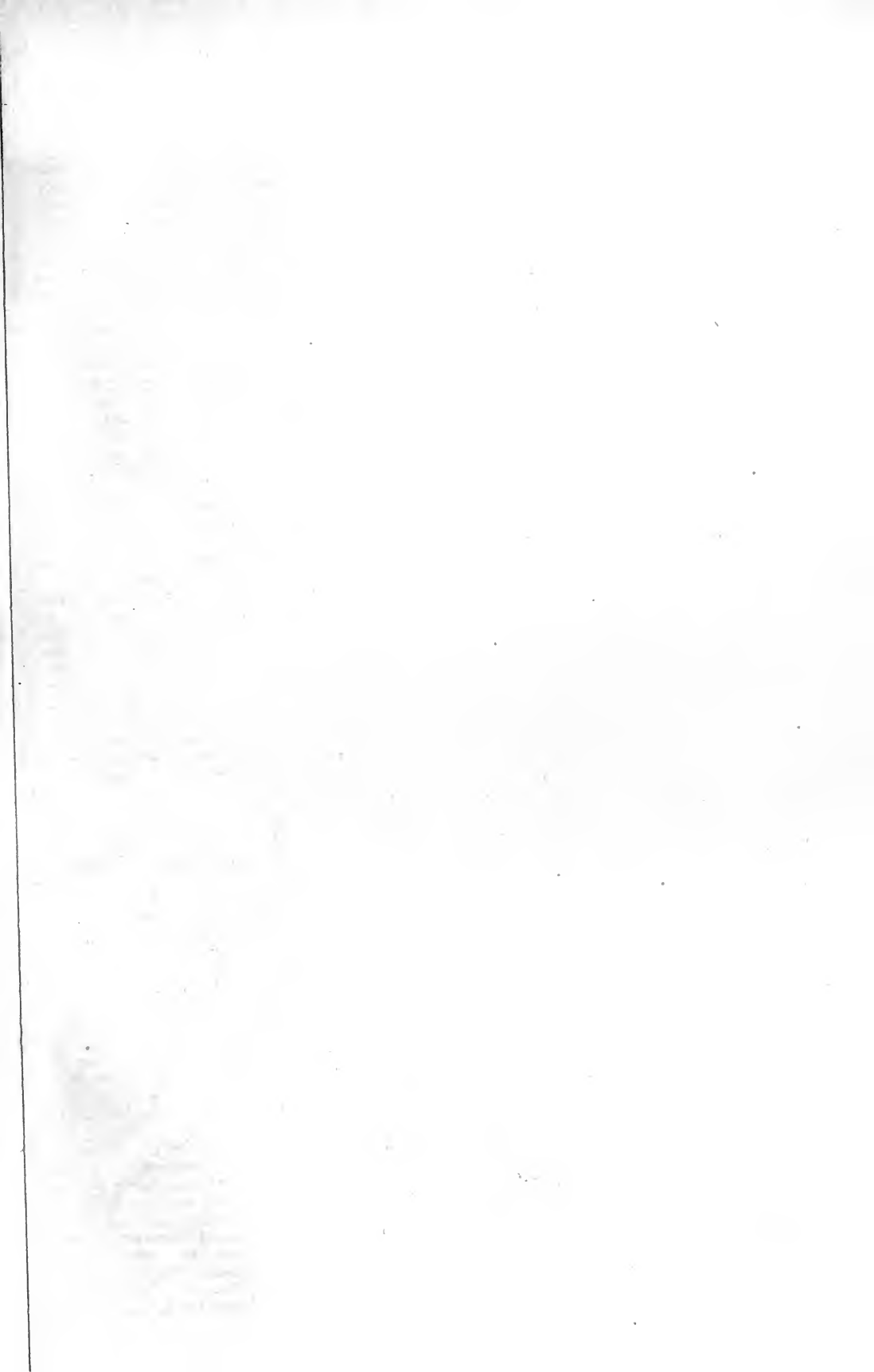

37° Longitude 42° East 47° from 52° Washington 62° 67° 72° 77° 82° 87° 92°



5° Longitude West 0° East from Greenwich 5° 10°

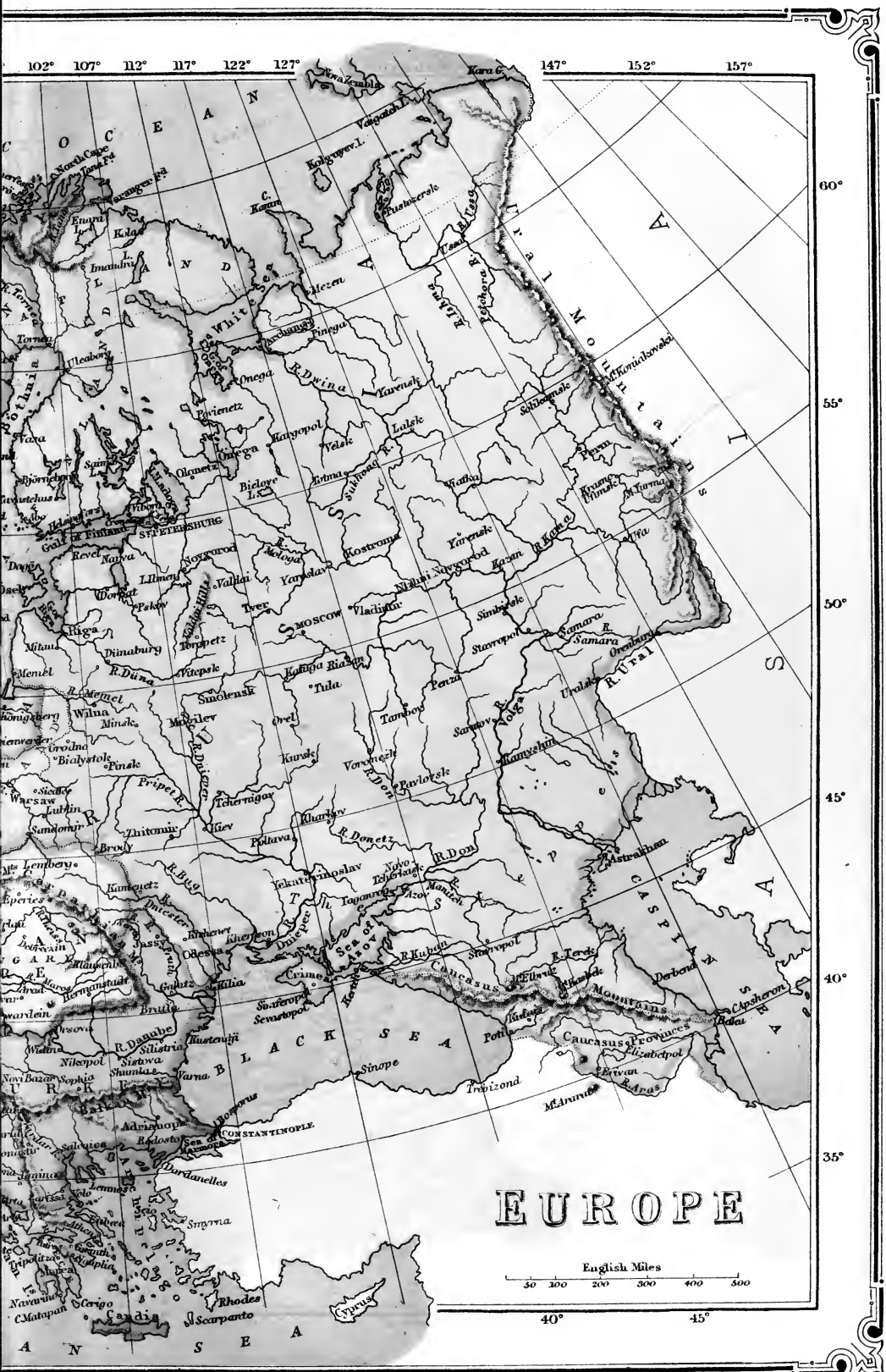

102° 107° 112° 117° 122° 127° 147° 152° 157°

60°  
55°  
50°  
45°  
40°  
35°

# EUROPE

English Miles  
50 100 200 300 400 500

40° 45°

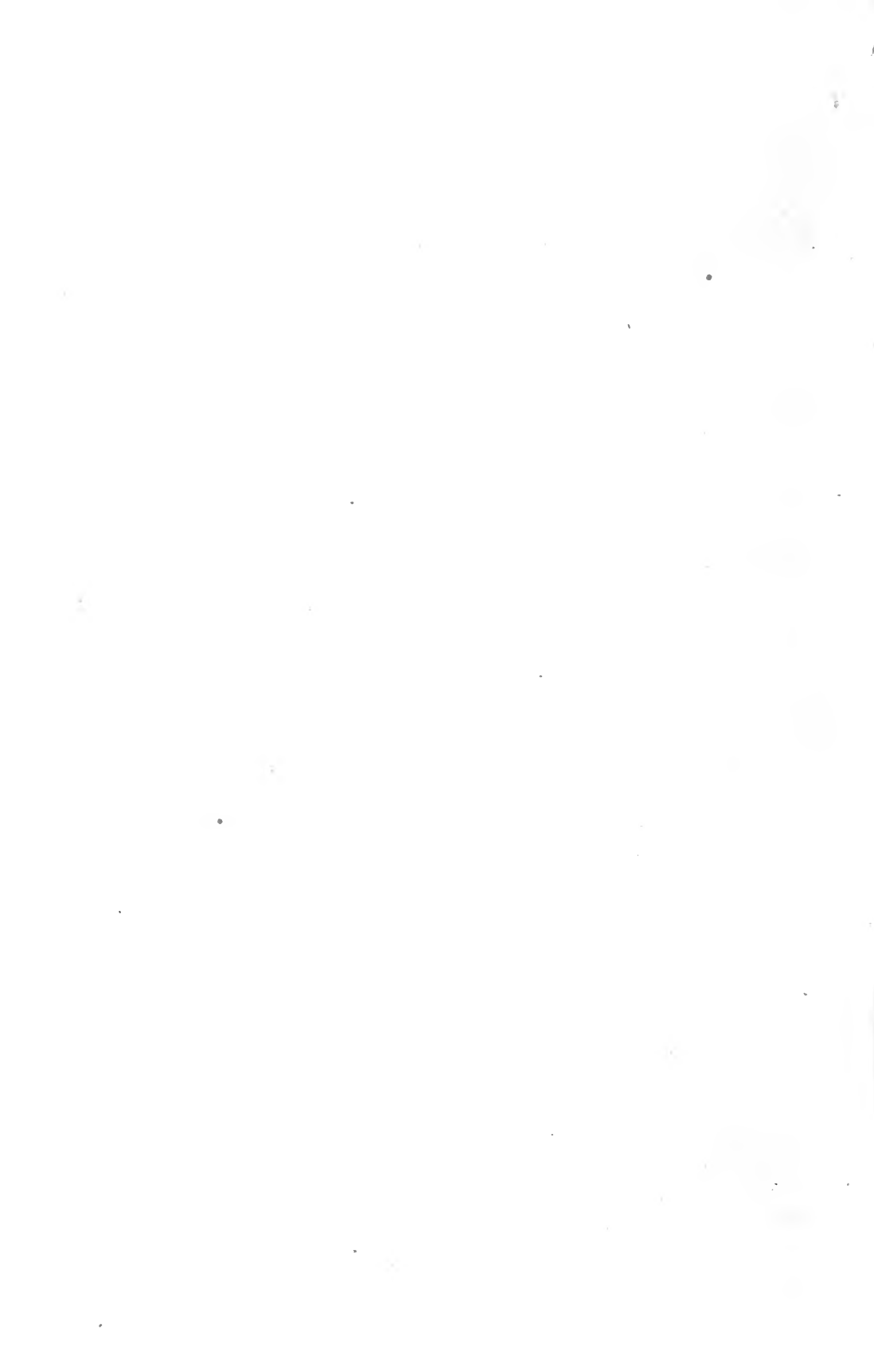

sea from Phœnicia to Crete. Hegesippus says there were three Europas: one a daughter of Oceanus, another a Phœnician princess, the daughter of Agenor, and the third a Thracian, in search of whom Cadmus left Asia. He derives the name of Europe from the last, Hippias and Andron from the first, and Herodotus from the second.

**EUROPE**, one of the five principal divisions of the globe, the smallest except Australia, but the most important in the history of civilization. Geographically considered, it is merely a N. W. peninsula of the Asiatic continent, but from the earliest times it has been distinguished as a separate division. The Greeks first applied the name to that portion of the continent nearest to them, and traced it to the myth of Europa. But there have been many other theories, none of which has remained uncontested. Ancient writers derive the name from Eurus, south wind, or from *εὐρώς* and *ἀπείρα* (a Scythic word, quoted by the Greeks), the broad land, or from *εὐρύς* and *ὄψις*, the broad-looking (land). Modern scholars have sought for the origin of the name in the Semitic languages. Thus Bochart derives it from the Hebrew word *ereb* (west), while others hold that it is a corrupt form of the words *'havra appa* (white-faced). If the name be Semitic, it must have been introduced by the Phœnicians, who were early familiar with almost all the shores of Europe. Their neighbors, the Hebrews, however, had no general name for the countries N. of the Mediterranean, though they were well known to them. The name of Europe does not appear in Homer's catalogue of countries, though it occurs, and so far as we know for the first time, in the Homeric hymn to Apollo. It is here applied to a region especially distinguished from the Peloponnesus and the Greek islands, but to exactly what portion of the then known world it is impossible to determine. Greece, the islands of the Ægean and Ionian seas, Sicily, Thrace, and a part of southern Italy, seem to have been all the territories now included under the designation of which the contemporaries of Homer had any definite knowledge. In the time of the historian Hecataeus (about 500 B. C.) some acquaintance had been made with the general features of Spain, southern Gaul, the region near the source of the Rhine, the borders of the lower Danube, and the shores of the Euxine and of the Palus Mæotis (sea of Azov); Italy, all the Mediterranean islands, and Thrace were now perfectly known. Herodotus, though in his day exploration had been carried much further to the north, placed the northern boundary of Europe (which he like his predecessors believed to be formed by the great river Oceanus) at a considerable distance south of the coast of the Baltic; but in his time the eastern and southeastern boundary afterward accepted as the limit of Europe by all the ancient nations, and formed by the Tanais river (Don), the Palus Mæotis, and the Cimmerian Bosphorus (strait of Yenikale), was

already well defined; the knowledge of northern and central Gaul had been largely increased, and all the south-central region was comparatively well known ground. Even in Strabo's time, when the North and Baltic seas were considered the extreme northern boundaries, the central and north-central portions of the continent were still but little explored; the present Russian possessions were almost entirely unknown: and though the great provinces conquered by Rome had now been thoroughly surveyed, it was not till the northern campaigns of Drusus Nero (B. C. 12-9) and of Germanicus (A. D. 14-16) that any really accurate knowledge of the northern Germanic regions appears to have been gained. About this period, too, the existence of the Scandinavian peninsula, northern Russia, and the Arctic ocean seems to have become known. From this time exploration and the knowledge of European geography made rapid progress; but it was not perfected until the political supremacy had passed from the Roman to the Germanic races.—Though much smaller in size than either Asia, Africa, or America, Europe has for many centuries exerted a greater influence upon the destiny of other portions of the globe than all the other divisions. For nearly 1,000 years subsequent to the downfall of the Roman empire, it is true, it slowly and laboriously struggled through barbarism at a time when the Mongolian race in eastern Asia had already attained a more perfect state of society and culture. It is only within the last four centuries that European civilization has matured so far as to be able to wield a controlling influence over distant regions and to stamp its seal upon their political state.—According to Ritter, Europe, with all islands belonging to it, has a superficies of 3,700,000 sq. m., and 20,780 m. of coast line, including 790 on the Caspian sea. Behm and Wagner (*Bevölkerung der Erde*, 1872) estimate the total area at 3,787,000 sq. m.; while the *Almanach de Gotha* and several other eminent statistical authorities agree in stating it at about 3,627,000 sq. m. Regarding the length of the coast line there is a much greater difference in the estimates, but Ritter's is probably nearly correct. The extreme points of the European continent are:

North:	Cape North,	lat. 71° 10' N.,	lon. 25° 46' E.
South:	Cape Taria,	" 36° 00' N.,	" 5° 36' W.
West:	Cape Roca,	" 38° 46' N.,	" 9° 31' W.
East:	Sea of Kara,	" 68° 00' N.,	" 66° 00' E.

The length of Europe from Cape St. Vincent in the southwest to the sea of Kara in the northeast is about 3,450 m.; the width from Cape North to Cape Matapan (the southernmost point of the Greek peninsula), 2,420 m. Europe is bounded N. by the Arctic ocean, E. by the Ural mountains and river and the Caspian sea, S. by the ridge of the Caucasus mountains, the Black sea, and the Mediterranean, and W. by the Atlantic ocean. The boundary line between Europe and Asia is somewhat un-

determined, but that which ascends the Ural river from its mouth at the Caspian sea to the Ural mountain range, and follows the crest of that range to the sea of Kara, is usually adopted. The islands of Nova Zembla are set down by Humboldt as properly belonging to Asia, since by their vertical configuration they appear as a continuation of the Ural range, which he included in Asia. Erman, on the contrary, shows their connection with the Scandinavian mountain system, and this is also the view taken by most English geographers. The continent proper has the shape of a rectangular triangle, the hypotenuse of which extends from the bay of Biscay to the sea of Kara, while the right angle rests on the Caspian sea. The area of this main body of the continent is about 2,650,000 sq. m., that of the peninsular projections about 860,000, and that of the islands nearly 200,000. Altogether Europe contains about  $\frac{7}{10}$  of the total area of the dry land of the globe. The proportion of the total area of the peninsular projections to the main body of the continent is as 1 to 3, a larger ratio than is found in any other division of the globe. A curved line drawn from a point in the Ural mountains, lat. 60° or 61° N., to the W. coast of Norway, lat. 69°, passing through Lake Onega and a little N. of the gulf of Bothnia, marks the general limit of cultivation. It cuts off an area of about 550,000 sq. m., or more than one seventh of the entire surface. Europe is surrounded by water on three sides. On the north the Arctic ocean, penetrating 400 m. into the continent, forms the White sea, which has an area of upward of 40,000 sq. m. Its coast, situated for the greatest part within the temperate zone, has become a seat of culture notwithstanding its high latitude. On the west the Atlantic ocean, narrowing between the British islands, the Scandinavian peninsula, and the continent, assumes the form of an inland sea (North sea, or German ocean, area upward of 200,000 sq. m.), which is connected by the Skager Rack and Cattegat with the Baltic sea. The Baltic, comparatively a shallow sea, and less salt than the ocean, is almost entirely land-locked. By its numerous affluents, however, it has obtained a commercial and even a political importance in the history of the Teutonic race almost equal to that of the Black sea in early Greek history. Its area, exclusive of islands, is over 150,000 sq. m. The configuration of the southern coast of Europe is determined by the Mediterranean sea (including the Adriatic and archipelago), a sheet of water over 2,300 m. in length, covering an area of over 1,000,000 sq. m. By its position it forms the connecting link between Europe, Asia, and Africa, and for more than 20 centuries the history of the Caucasian race was principally developed upon its coast. The Black sea, connected with the Mediterranean by a narrow channel, is 700 m. long, 400 m. broad, and has a superficies of 180,000 sq. m. exclusive of the sea of Azov. In consequence of the deep in-

dentations of the sea, the western half of Europe contains no great inland country shut up from direct communication with the ocean. The distance from the bay of Biscay to the gulf of Lyons is only about 240 m.; from the English channel to the same gulf, 445 m.; from the Pomeranian shore of the Baltic to the gulf of Trieste, 585 m.; from the gulf of Dantzic to the Black sea, 740 m.; from the gulf of Finland to the sea of Azov, 950 m.; from the White sea to the sea of Azov, 1,160 m.; and from the sea of Kara to the Caspian sea, 1,575 m. Twelve large peninsulas are formed by indentations of the sea, five of them on the north: Kanin, Kola, the Scandinavian peninsula, the Cimbric, and North Holland; two on the west: Normandy and Brittany; one on the southwest: the Iberian; and four on the south: Italy, Istria, Greece, and the Crimea. The first two of the five northern peninsulas stretch toward the Arctic ocean, and are consequently almost uninhabitable. The largest of the five (the Scandinavian) has a southern direction. Thus only a small portion of the coast configuration is lost to culture and commerce. The islands, too, with the exception of Iceland, cluster so closely around the continent that, in considering the natural facilities which Europe offers to commercial intercourse, their coast line might be added to that of the continent. The principal of them are: the main island of Great Britain, Ireland, Iceland, Seeland, Corsica, Sardinia, and Candia. The following may also be mentioned: Nova Zembla and Vaigatch, in the Arctic ocean; the Loffoden, on the coast of Norway; the Aland archipelago, Öland, Gotland, Oesel, in the Baltic; Fünen, between the two Belts; the Azores, in the Atlantic; Majorca, Minorca, Elba, the Lipari islands, Malta, the Dalmatian archipelago, the Ionian islands, the Sporades and Cyclades, in the Mediterranean sea and its branches.—The same direction from S. W. to N. E. which prevails in the coast configuration is perceptible in the position of the mountains and their different strata. All the peninsulas, those stretching to the northward excepted, are mountainous, as are the islands, while the plains cover the largest portion of the main body of the continent. The proportion of the plains to the mountainous regions in all Europe is as 5 to 2; but in that portion of Europe which has been preëminently the seat of civilization and the theatre of history, the mountains prevail over the plains as 3 to 1. A diagonal line of mountain ranges, extending from S. E. to N. W. (Caucasus, Carpathians, and the mountains of central Germany), forms the dividing line between the mountainous and the level portions of Europe. The level region extending from the shores of the North sea to the Ural, and from the coast of the Netherlands in an irregular southeasterly direction to the Black sea, appears as a western continuation of the steppes of Siberia and Turan, intersected by the isolated Ural range. While on the shores of



the North sea its width is less than 100 m., in the extreme east it is 1,400 m. wide. Its entire length is near 2,300 m., its area about 2,000,000 sq. m. Proceeding from the heaths of West Brabant in an easterly direction, even beyond the Ural passes to the steppes on the western slope of the Altai mountains, 80 degrees of longitude, no elevation of over 1,200 or 1,300 ft. above the level of the sea is met with. The western or European portion of this plain appears to have formed, after the commencement of the tertiary period of geology, the bed of the sea. It includes the basins of the Baltic and White seas. A part of it is traversed by rivers flowing northward from the Alps, the mountains of central Germany, and the Carpathians. To the eastward the watershed between the Baltic and the Black and Caspian seas is only a few hundred feet in elevation; commencing at a spur of the Carpathians near the source of the Dniester, it runs through the Russian governments of Volhynia, Grodno, Minsk, Mohilev, Smolensk, Pskov, Tver, Novgorod, and Vologda, to the Ural range. Though interspersed with marshes, bogs, and heaths, this immense plain is susceptible of high culture, but nowhere is the soil so fertile as to produce crops without laborious diligence. Connected with this large plain are two lesser ones, in France and in Hungary.—The mountain system of southern and western Europe is grouped around the central mass of the Alps, which forms the summit and the principal watershed of the continent. The Alps, covering an area of nearly 100,000 sq. m., slope down on four sides toward France, Germany, Hungary, and Italy. The highest elevation of this system and of all Europe is Mont Blanc (15,732 ft., according to Bruguère). The lowest limit of perpetual snow in the Alps is 8,760 ft., between lat. 45° and 46° N. Connected with the Alpine system are the mountain systems of the three southern peninsulas, viz., the Pyrenean system, the Apennines, and the Balkan, and also the group of the Carpathian and Sudetic mountains. The Pyrenees stretch from E. to W. for 240 m., but, including the Cantabrian mountains, their length is 500 m. Their S. side, toward Spain, is rugged and precipitous, while on the north they descend gradually by a series of parallel ridges into France. They send four principal branches through the Iberian peninsula, the whole system covering a superficial area of about 200,000 sq. m. The culminating point of the system, in its widest acceptance, is the Cerro de Mulhacen in the Sierra Nevada (11,654 ft.). The Apennines, stretching from the Alps through the entire length of Italy to the strait of Messina, cover an area of 60,000 sq. m. Their highest summit is Monte Corno (9,542 ft.). The Carpathian and Sudetic mountains, with the Erzgebirge and the Bohemian Forest, form one chain extending 1,200 m. in length, from the Danube in Hungary to the same river in Bavaria. Their highest elevations, from 6,000 to 9,000 ft., are in Transyl-

vania and Hungary, where they surpass the lower limit of perpetual snow. The Balkan, a direct continuation of the Dinaric Alps, sweeps in an irregular curve from the Adriatic to the Black sea. Its principal part is the Hæmus of the ancients. Its general elevation is about 4,000 ft.; a few of its summits rise about 4,000 ft. higher. Thence one range, including the ancient Pindus, diverges to the south, dividing Albania from Roumelia, and connecting with the mountains of Greece, the loftiest summits of which attain an elevation of upward of 8,000 ft. Another, the Rhodope of the ancients, now called Despoto Dagh, diverges further E. in a S. E. direction, and, traversing western Thrace, reaches the archipelago. The Rilo Dagh, near its starting point, is 9,838 ft. high. Between the two are various branches, one of which includes Mt. Olympus, 9,754 ft. Between the Alpine system proper, the Pyrenees, and the Atlantic (in France), there are three separate mountain ranges, viz., the Cévennes and mountains of Auvergne, the Jura, and the Vosges. The first divides the low country on the Mediterranean and the basin of the Rhône from the plains extending W. to the Atlantic; its general elevation is from 3,000 to 5,000 ft., though some peaks (Mont Dore, Cantal, and Mont Mezin) rise to a height of about 6,000 ft. The Jura, of nearly the same elevation, extends along the frontier of France and Switzerland. Further N. the Vosges divide the basin of the Rhine from that of the Moselle, their loftiest summits reaching an altitude of about 4,700 ft. There are several plains, independent and differing in their principal features from the great northern plain, enclosed by the Alpine system, namely, the basins of the Po, the Rhône, and the upper Rhine. Besides the above mentioned ranges, all more or less immediately connected with the central system of the Alps, Europe contains in its islands and peninsulas five distinct mountain systems. They are the Sardo-Corsican, the Tauric, the British-Hibernian, the Scandinavian, and the Sarmatian. The Sardo-Corsican, as its designation implies, is the range of mountains stretching from N. to S. through the islands of Corsica and Sardinia; its highest summit, Monte Rotondo in Corsica, has an elevation of 9,054 ft. The Tauric system is confined to the southern portion of the Crimea, its greatest elevation being 4,740 ft. The British-Hibernian system, in Great Britain and Ireland, is comparatively insignificant, rising in its highest peaks (in Scotland) but little over 4,000 ft. The Scandinavian Alps (Kiölen and Dovrefield) extend 1,000 m. from N. to S. through the entire length of the Scandinavian peninsula, at a general elevation of from 3,000 to 6,000 ft. The highest summits are Ymes Field, 8,540 ft., Skagtöls Tind, 8,061, and the Sneehætten, 7,562 ft. In the N. portion the lower limit of perpetual snow is at 3,500 ft. above the level of the sea. The Sarmatian system consists only of a few scattered hill chains in Russia,

Poland, and the N. E. part of Prussia; its greatest elevation, in the plateau of Valdai, is only 1,150 ft. The Ural range, which forms the northern portion of the E. boundary line of Europe, extends from N. to S. through 18 degrees of latitude, with a general elevation of about 2,000 ft., several summits rising to a height of more than 5,000 ft. Toward the south it diverges into smaller ridges that extend to the Caspian sea, the sea of Aral, and the steppes of the Kirghiz. A volcanic belt extends through the southernmost portion of Europe from central Asia and Asia Minor through the archipelago, Greece, Naples, Sicily, Spain, and Portugal, to the Azores. Along this line destructive earthquakes are of frequent occurrence. Besides many extinct craters, there are two active volcanoes, Etna in Sicily and Vesuvius near Naples. In the north, Iceland constitutes a distinct volcanic region. Its principal volcano is Mt. Hecla, some eruptions of which have lasted for six years. The S. W. portion of the island contains the famous geysers, or intermittent springs of steam and boiling water. There are two other volcanoes, one on the island of Jan Mayen, between Iceland and Spitzbergen, the other on the northern island of Nova Zembla.—The river systems of Europe are less extensive than those of either Asia or America. The principal watershed, running S. W. and N. E., from the strait of Gibraltar to the sea of Kara, divides the continent into a S. E. and a N. W. slope, the former containing about four sevenths and the latter three sevenths of the total area. On the S. E. slope the basin of the Caspian sea comprises over 500,000 sq. m.; that of the Black sea and the sea of Azov about 950,000 sq. m.; and the basin of the Mediterranean sea, 575,000 sq. m. On the N. W. slope the Atlantic basin and the basin of the Baltic comprise about 450,000 sq. m. each, the basin of the North sea 400,000, and that of the Arctic ocean nearly 200,000. The following are some of the more important rivers flowing into the different seas: 1, Caspian sea: Ural and Volga; 2, sea of Azov: Don; 3, Black sea: Dnieper, Dniester, Danube; 4, Mediterranean: Maritza, Isonzo, Adige, Po, Tiber, Arno, Var, Rhône, Ebro; 5, Atlantic: Minho, Douro, Tagus, Guadiana, Guadalquivir; 6, bay of Biscay: Garonne, Loire; 7, British channel: Seine, Somme; 8, North sea: Scheldt, Rhine, Ems, Weser, Elbe, Eider; 9, Cattegat: Glommen; 10, Baltic sea: Ulea, Neva, Düna, Niemen, Vistula, Oder, Dal Elf, Angermann Elf, Umea Elf, Pitea Elf, Lulea Elf, Tornea Elf; 11, Arctic ocean: Onega, Dwina, Mezen, Petchora. Besides these, there are the rivers of the British islands, the chief of which are the Thames, Severn, Humber, and Mersey, in England; the Tweed, Clyde, and Forth, in Scotland; the Shannon, Blackwater, Liffey, and Boyne, in Ireland. The largest river of Europe is the Volga, with a course of 2,000 m. and a basin of 500,000 sq. m.; next comes the Danube,

with a length of 1,820 m. and a basin of 300,000 sq. m. Artificial watercourses connect the Caspian sea, the Baltic, and the Arctic ocean, by the Volga, Neva, Düna, and Dwina rivers; the Black and the North sea by the Danube and Rhine; the Mediterranean and the Atlantic ocean, the British channel and the North sea, by numerous canals between the Rhône, Garonne, Loire, Seine, Scheldt, and Rhine. The middle course of most of the large rivers is well adapted to navigation by steam and other vessels, but their usefulness for the purposes of commerce is restricted by obstructions at their mouths. Such is especially the case with the Volga, Don, Danube, and Rhine.—The lakes of Europe are small, and scarcely any of them are important to commerce. The following are among the largest: Ladoga (between 6,000 and 7,000 sq. m.), Onega, Saima, and Enare, in Russia; Wener (about 2,000), Wetter, and Mælar, in Sweden; Lake Balaton (450), in Hungary; the lakes of Geneva and Constance in Switzerland; and Garda and Lago Maggiore, in Italy. Four fifths of the lakes in Europe are situated in the region around the Baltic sea. (The geology of Europe is treated under the special heads of the different countries and mountain ranges.)—The whole of Europe, with the exception of a small northernmost portion of the Scandinavian peninsula and Russia, being situated within the temperate zone, enjoys an equable and temperate climate. The disadvantages arising from the proximity of the Arctic ocean and the climatic influences of northern Asia are more than overborne by many advantages which no other division of the globe enjoys in an equal degree. The prevailing winds are western, and hence before reaching Europe have been in contact with an expanse of water, the surface of which has, even in January and in lat. 45°–50° N., rarely a lower temperature than 50° F. In the second place, Europe is influenced by a broad tropical zone, including Africa and Arabia, whose dry soil serves to warm the air carried to Europe by southern winds. On the other hand, the influence of the Arctic ocean upon the climate of the continent is neutralized by the Gulf stream. The combination of all these advantages explains the fact that the mean temperature of Europe is higher than that of any other division of the globe in corresponding latitudes, the isothermal lines of Asia and America bending in Europe to the northward by some 10 degrees of latitude. Thus in lat. 36° N. the mean temperature of the year is 66° F., and in lat. 71° N. (Cape North) it is 32° F., not lower than in lat. 56° N. on the E. coast of Asia and America. Owing to the causes before mentioned, the mean temperature of Europe is higher and the extremes are less in the same latitudes in the western than in the eastern part. The isothermal line of 50° F. (mean annual temperature) runs from London to Cracow and Odessa, that is to say, from lat. 51° 30' to 46° 22' N., thus declining

5° of latitude to the south in a course of 31° 5' of longitude. A mean annual temperature of 68° is only met with on the southern coast of Portugal. But while the mean temperature diminishes advancing eastward, the extremes of the heat of summer and the cold of winter increase. Thus London has the same mean temperature as Vienna, which lies more than 3° further S., but it has the summer of St. Petersburg and the winter of Milan. The transitions from winter to summer and from summer to winter are less abrupt in the largest portion of Europe than they are in America. Almost everywhere the seasons succeed each other with great regularity. The extreme north only, where the winter lasts for eight months, and the extreme south, form exceptions. The fall of rain is more equally distributed N. of the Alpine system than S. of it. It has been calculated that the entire quantity of rain falling in the N. part of Europe is less by one third than in the S., but the snow of the north covers the deficiency of rain. The western winds, being laden with the moisture which they have received in passing the Atlantic, generally bring rain, while the eastern winds are dry and chilly. From the same cause the average quantity of rain is largest in Great Britain, and decreases in advancing E. and S. E. Thunderstorms occur in the N. part of Europe almost exclusively during the summer, in the S. part at all seasons of the year.—The vegetation of Europe, dependent upon and corresponding to its climate, has not the extremes of luxuriance or sterility belonging to other great continents. Culture has diversified it, and has domesticated many plants, natives of other countries. Thus the vine, olive, and mulberry have been introduced from Syria, the cotton plant from India, maize from North America, the potato from South America, the walnut and peach from Persia, the apricot from Armenia, the sugar cane and orange from China; while many of the indigenous plants, especially vegetables (as lettuce, cabbage, turnips), have been improved by culture to such a degree that their relationship with their wild types is scarcely evident. Europe may be divided into three vegetable zones, viz.: 1. The sub-arctic zone, characterized by the prevalence of the pine and birch and of cryptogamous plants. It produces little grain except barley, and no fruit. This zone comprises Iceland, the Faroe islands, the Scandinavian peninsula N. of lat. 64°, and Russia N. of lat. 62°. 2. The central zone, subdivided into the zone of the beech and oak, and that of the chestnut and vine. The former includes Great Britain and Ireland, the Scandinavian peninsula S. of lat. 64° N., and the German and Sarmatian plain between lat. 62° and 48°. The latter comprises the valleys and plains between the mountain ranges of central Europe and the Sarmatian plain. In the former, rye and wheat are the principal grains; in the latter, wheat and maize. 3. The southern zone, or

the region of perpetual verdure, and of the olive, comprising the three southern peninsulas and the southern coast country of France, distinguished by a great variety and luxuriance of sub-tropical vegetation. The sugar cane, cotton plant, orange, citron, fig, pomegranate, and date grow in the southernmost belt of this region. The zones in which these fruits and plants grow follow the lines of equal summer heat, and hence run from S. W. to N. E., since the extremes of summer heat and winter cold increase advancing eastward, though the mean annual temperature decreases. Thus the cotton plant is cultivated on a small scale in the southernmost portion of Spain, from lat. 36° to 37°, more largely in Sicily and in the S. E. angle of Italy, in the Balkan peninsula as high as lat. 41° 30', and at Astrakhan in lat. 46°. The olive, which does not succeed on the W. coast of France in lat. 43°, grows as far as lat. 44–45° in the S. E. provinces of France and in Italy. The fig and pomegranate, which accompany the olive in the west, are found in the Crimea as far N. as lat. 45°. The climate proper for the culture of maize terminates on the W. coast of France at lat. 45° 30', on the Rhine at 49°, and on the Elbe at 50–51°. Rice has nearly the same geographical range. The culture of the vine extends as far N. as lat. 47° 30' on the Atlantic coast, 50° 30' on the banks of the Rhine, 52° on the Oder river. In Russia it grows as far N. as lat. 52°, but it is not cultivated beyond 50°. Altogether the region adapted to the cultivation of the vine comprises about three sevenths of Europe, that adapted to the culture of wheat four sevenths. The N. limit of the latter is lat. 57–58° N., though it is raised in a few favored spots in Finland as far N. as lat. 60° and 61°. The hardier kinds of grain, rye, barley, and oats, are cultivated on the W. side of Norway as far as lat. 69° 55' N., but on the E. side of the Scandinavian mountains they scarcely ripen at 67–68°, and still further E. in Russia they cannot be cultivated beyond lat. 60–62°. Peaches and apricots succeed in Russia as far N. as lat. 50°, melons at lat. 52°; and plums and cherries, growing wild as far as lat. 55°, are carried beyond that limit by cultivation. Tobacco is extensively cultivated over the greater part of Europe, from Sicily to Sweden, as are flax and hemp, though they thrive best between lat. 45° and 60°.—Europe contains the various minerals, though in unequal proportions. It is abundantly supplied with iron, copper, lead, coal, and salt, but produces comparatively small quantities of gold and silver. Gold, though widely diffused, is only found in a few places (Carpathians, Ural mountains, and Scandinavian Alps) in sufficient quantities to repay the expense of working it. Silver is mined in the Hartz, the Carpathians, Ural mountains, Scandinavian Alps, and Sardinia. The richest iron mines are in Sweden, which produces the best quality, in Great Britain, which has the largest quantity, in Styria, Carinthia, Bavaria, the Py-

rences, the Carpathians, and the Hartz mountains. Copper is less abundant than iron; the richest mines of this metal are to be found in Hungary, the Saxon and Bohemian mountains, in England, the Ural mountains, and the Scandinavian Alps. Lead is wrought in most of the large mountain ranges, tin only in a few places (Cornwall and the Hartz). Mercury is likewise confined to a few spots, as the mines of Idria in Carniola, Zweibrücken in the Palatinate, and the Spanish province of La Mancha. The richest coal fields exist in the N. and W. parts of England, on both sides of the middle region of Scotland, in Ireland, Belgium, France, Germany, Hungary, Catalonia in Spain, and Sardinia. Salt is either obtained by the evaporation of brine from salt springs, or from depositories of mineral salt, of which the most extensive are found within the Austro-Hungarian empire at Wieliczka, in Marmaros, and in Salzburg. Salt springs are numerous along the sides of all mountains belonging to the primitive formation. Large quantities of salt are also collected from the salt lakes of the Crimea. Zinc is wrought in England and Germany, and cobalt in Saxony and Sweden. Besides these metals, antimony, bismuth, manganese, sulphur, alum, &c., are obtained in larger or smaller quantities in the different mountain chains.—The animal kingdom of Europe is far less varied than the flora. The diversities of the three zoölogical regions are inconsiderable, and the only real contrast is between the arctic animals of the extreme north, as the reindeer, white bear, &c., and the beasts of prey of the extreme south, the lynx, wild cat, &c. The original features of the fauna of Europe have been greatly modified by culture. Several species of wild animals have disappeared entirely in many countries, as the wolf and bear in Great Britain and in some parts of the continent, while others are becoming scarcer from year to year. Thus the aurochs and the elk in some provinces of Russia, the porcupine in the extreme south, the monkey near Gibraltar, the chamois and ibex in the higher mountain ranges. But if Europe is poor in wild beasts, it is rich in domestic animals. In the northernmost region, as far S. as lat. 63° in Russia, the domesticated reindeer abounds; central Europe has immense numbers of horses, horned cattle, sheep, goats, and hogs; and southern Europe possesses, besides these, mules, camels (in South Russia), and buffaloes. Of small birds Europe has several hundred species, but many of them are only birds of passage. Among those kinds of birds peculiar to certain regions are the flamingo, spoonbill, pelican, and vulture in the south, gray eagle in the north, eider duck, swan, and red grouse in the north and north-east, bee-eater in the southeast, white owl in the extreme north, &c. Various species of turtles excepted, Europe has no large amphibia. Fish are more abundant on the N. than on the S. coast; herring and codfish are found only in the north, sturgeon in the Rus-

sian rivers and seas, anchovies and pilchards on the S. W. coast, tunny fish in the Mediterranean. Of insects, several kinds of tarantula and scorpions are peculiar to Europe. The silk-worm is raised principally in the southern countries, and the honey bee in all the temperate portions of the continent. The annelids of Europe include the medicinal leech (in Sweden, Germany, Hungary, and Poland). Europe is abundantly supplied with edible mollusks, but they are found in greater abundance and better quality in the Mediterranean sea than on the N. coast. Radiated animals, zoöphytes, &c., also abound on the S. coasts, where some of them (the actinias) are used as food, and where the coral fisheries employ many persons. Generally the S. part of Europe possesses a greater variety of animals and species than the N., while the latter has them in greater numbers.—The inhabitants of Europe are the descendants of many different tribes, though the great majority belong to the Indo-European branch of the human family, and would seem to have sprung originally from a common stock. Without referring to the prehistoric migrations of the various races which are more or less distinctly traceable through philological and archæological investigation, and which are treated in other articles, it is sufficient to indicate in this place the positions occupied by the different peoples at the period of the earliest written records; as it is from nations then already settled in the continent that the present population is almost entirely derived. At the dawn of history, then, the W. and S. W. portions of Europe appear to have been in possession of the Celts and the Iberians. In the east and north-east the Ugrian (Mongolian) races (part of the Scythians of the ancients), of whom the Lapps, Finns, Samoyeds, and Magyars are the present remains, seem to have been the original inhabitants. At an early period the Slavs settled in the countries N. of the Black sea, and pressing N. E. gradually dispossessed the Ugrians of their country. Between the Ugrian and Slavic races of the east and the Celts of the west, the Germanic races are found at the earliest period of traditionary history pressing N. to conquer Scandinavia and S. against France and Italy. The southeast of Europe was probably settled from Asia and Africa; history finds in Greece and Italy two races who afterward became known as the Hellenic and Roman. The former was the first to develop in Europe a high state of culture, which, having been received by the conquering Roman race, was carried over all the countries around the Mediterranean. Having exhausted their power, the Roman conquerors were in their turn overthrown by the hardy, vigorous, and barbarous northern nations, who, after having embraced Christianity, in the course of many centuries developed a new and different civilization. The Heruli, Ostrogoths, Longobards, and other Teutonic tribes, penetrated into and settled in Italy; Suevi, Visigoths, and Vandals in Spain; Franks

and Burgundians in Gaul (France); Angles, Saxons, Jutes, and Frisians in Britain. In Italy, Spain, and France, the conquerors were mostly assimilated to the nations whom they had found there, and by their admixture with them the present so-called Latin or Romanic race was produced. In Britain, the invaders drove the original inhabitants into Wales, Cornwall, and Cumberland, but were in their turn invaded by Normans and French in the 11th century; and the admixture of all these different elements, Celtic, Anglo-Saxon, and Norman, gradually produced the present English race. In Spain, the Teutonic tribes were overrun by Arabs in the 8th century, and did not recover possession of the whole country for nearly eight centuries. In the southeast the Hellenic race became during the middle ages largely mixed with the Slavic, while around the lower course of the Danube an intermixture of the ancient Dacians with a Roman colony produced the present Rouman or Wallach race. Toward the end of the 9th century an Ugric race settled in the ancient Pannonia, where they remain to the present day under the names of Magyars and Szeklers in Hungary and Transylvania. Of the Tartars who under Genghis Khan entered Europe in the 13th century, and kept possession of a large portion of Russia till the end of the 15th century, some descendants still remain in the south of that empire. The Osmanli, another branch of the Mongolian race, invaded Europe in the 14th century, and have ever since kept possession of the S. E. corner of the continent. By mingling freely with western nations they have lost many characteristic features of the Mongolian stock. —The population of Europe, which can now be estimated with accuracy, owing to the fact that official censuses are taken in all countries of the continent, amounted in 1872, according to the best authorities, to about 301,000,000, or about 80 to the square mile. Its distribution between the E. and W. portions is very unequal, the average population on a square mile being about 34 in Russia, which occupies the eastern half of the continent, and about 125 in the west. With the exception of the three free cities in Germany, the canton of Geneva, and Malta, the greatest density of population prevails in Belgium (447); then follow in order the Netherlands (279), Great Britain and Ireland (263), Italy (234), Germany (197), France (177), Switzerland (167), Austria (149), Denmark (121), Portugal (117), Spain (85), Turkey (80), Greece (75), Russia (34), Sweden (27), and Norway (15). The average natural increase per annum of the population varies from 0.5 to 1.43 per cent. It is 1.43 per cent. in Great Britain, 1.16 in Prussia, 0.6 in all Germany, 0.59 in France. Ireland is the only country in which there has been of late a steady decrease of population. There were in Europe in 1872, in all, 67 cities with more than 100,000 inhabitants to each. The following table exhibits in round figures the

comparative numbers of different races among the present population of Europe:

I. INDO-EUROPEAN OR ARYAN FAMILY.	
1. Græco-Latin races.	
<i>a.</i> Greeks.....	8,000,000
<i>b.</i> Latin nations.....	
<i>a.</i> Italians.....	27,000,000
<i>β.</i> Rhetians (in Switzerland, Tyrol, &c.).....	100,000
<i>γ.</i> French (including the Provençals).....	37,000,000
<i>δ.</i> Spaniards and Portuguese..	19,000,000
<i>ε.</i> Roumans.....	8,000,000
	94,100,000
2. Celtic race.	
<i>a.</i> Celts in the British isles.....	6,500,000
<i>b.</i> Celts in Brittany.....	1,000,000
	7,500,000
3. Germanic or Teutonic races.	
<i>a.</i> Germans, Dutch, and Flemings.	56,000,000
<i>b.</i> Scandinavians (Danes, Norwegians, Swedes, Icelanders).....	8,000,000
<i>c.</i> English (Anglo-Saxons).....	23,500,000
	87,500,000
4. Slavic races.	
<i>a.</i> Russians (including Ruthenians, &c.).....	57,000,000
<i>b.</i> Poles.....	11,000,000
<i>c.</i> Wends.....	150,000
<i>d.</i> Czechs and Slovaks.....	7,000,000
<i>e.</i> Illyro-Serbs (Serbs, Croats, Slavons, Dalmatians, Slovens, Bosnians, Herzegovinians, Montegrins).....	7,500,000
<i>f.</i> Bulgarians.....	5,000,000
	87,650,000
5. Letts and Lithuanians.....	
	8,000,000
6. Caucasian races.	
<i>a.</i> Georgians, Armenians, &c.....	1,500,000
<i>b.</i> Caucasian tribes.....	1,000,000
	2,500,000
7. Albanians.....	
	1,500,000
8. Basques.....	
	800,000
9. Gypsies and scattered inhabitants of Indian race.....	
	250,000
	284,500,000
II. SEMITIC FAMILY.	
1. Jews.....	5,000,000
2. Arabs (Moors and Maltese).....	100,000
	5,100,000
III. MONGOLIAN OR TURANIAN FAMILY.	
1. Tchudic branch of the Finnic race.	
<i>a.</i> Finns proper.....	1,500,000
<i>b.</i> Esthoniens.....	500,000
<i>c.</i> Lapps, Tchuds.....	50,000
	2,050,000
2. Magyars (including Szeklers).....	
	5,500,000
3. Turks.	
<i>a.</i> Osmanli.....	1,750,000
<i>b.</i> Mixed Turkish and Tartar peoples.....	1,000,000
	2,750,000
4. Minor tribes (Samoyeds, Votiaks, Mordvins, &c.).....	
	1,500,000
	11,800,000
	801,700,000

—For the classification of the languages, which almost closely correspond to the races and peoples enumerated in the table, see ARYAN LANGUAGES, ETHNOLOGY, SLAVIC RACE AND LANGUAGES, and TURANIAN RACE AND LANGUAGES. —With the exception of China proper, the physical culture of no other part of the world is so much developed as that of Europe. Of the total area, 20 or 23 per cent. is non-productive, being either lakes, rivers, swamps, rocks, or occupied by buildings, or, like the extreme northern portion, unfit for human habi-

tation; 36 per cent. is devoted to agriculture or cattle raising; and over 40 per cent. is in forests, of which Russia alone has more than 1,000,000 sq. m. The best cultivated countries are Great Britain, Germany, and France. The introduction of scientific methods of agriculture into these countries has tended steadily to increase the productive capacities of the soil. The average crop of grain to the acre is considerably larger than in the United States. The last trustworthy estimate of the number and value of domestic animals in Europe, as computed by Reden about 1860, gives the statistics as follows: Horses 27,000,000, valued at \$775,470,000; horned cattle 80,000,000, value \$864,720,000; sheep 191,000,000, value \$687,600,000; asses 1,800,000, value \$12,600,000; goats 16,800,000, value \$36,450,000; hogs 37,500,000, value \$108,240,000; mules 800,000, value \$17,160,000; aggregate value of domestic animals, \$2,502,210,000. The average yearly mineral production was estimated as follows by Kolb in 1871: gold, 53,000 lbs.; silver, 470,000 lbs.; iron, 177,000,000 cwt.; copper, 916,000 cwt.; lead, 4,510,000 cwt.; coal and brown coal, 3,450,000,000 cwt.; salt, 100,000,000 cwt. The industrial production is largest in Great Britain, Belgium, France, and Germany. The total annual value of European commerce was estimated by Kolb in 1871 at \$7,960,000,000; but he called attention to the fact that as all goods are counted in one country as imports and in another as exports, and many in a third also in the transit trade, the real value must be considerably less than half the apparent value above stated.—Christianity is almost exclusively the religion professed by the nations of Europe. The three

principal denominations, Roman Catholic, Protestant, and Greek, correspond nearly to the three principal races, Latin, Teutonic, and Slavic. Geographically, the Roman Catholic is the dominant religion in the south and southwest, the Greek Catholic in the east and southeast, and the Protestant in the north and northwest. The number of Mohammedans is about 5,000,000 (3,500,000 in Turkey, the remainder in S. Russia), of Jews 5,000,000, of Buddhists about 10,000 (Mongolian nomadic tribes in S. Russia), and of pagans less than 1,000,000 (in the extreme north of Russia).—Popular education, measured by the proportion of schools and pupils to the entire population, is more general in the countries inhabited by the Teutonic race than among the Latin nations, and it holds the lowest place among the Slavic nations. In Germany, Sweden, Norway, and Denmark the proportion of pupils to the population is 1 to 6; in Belgium, 1 to 8·8; in Great Britain, 1 to 9·1; in France, 1 to 10·1; in Holland, 1 to 10·9; in Austria, 1 to 11·2; in Spain, 1 to 14·3; in Italy, 1 to 15·1; in Russia, 1 to 66·6.—Among the nations of Europe almost every form of government exists, from that having at its head an almost absolute personal ruler, to the several systems of the most restricted monarchy and the republic. The nature of the government of each is indicated in the following table, which exhibits the states of Europe as constituted in 1874, with their areas and the number of their population; and shows also their division, made for purposes of diplomatic intercourse, into four ranks according to their power and general status—a distinction which, however, is now less strictly marked than formerly:

NAMES OF STATES.	Form of government.	Area in sq. miles.	Population.	Date of census.
<b>States of the first rank.</b>				
Russia in Europe.....	Empire.....	2,050,225	71,195,405	1867
The German empire.....	Empire.....	205,619	41,058,139	1871
France.....	Republic.....	204,091	36,102,921	1872
The Austro-Hungarian monarchy.....	Empire.....	240,348	35,904,485	1869
Great Britain and Ireland.....	Kingdom.....	121,115	31,977,477	1871
Italy.....	Kingdom.....	114,295	26,716,809	1871
<b>States of the second rank.</b>				
Spain*.....	Republic.....	195,774	16,641,880	1867
Turkey in Europe (exclusive of Roumania).....	Empire.....	152,508	12,000,000	estimated.
Sweden and Norway.....	Kingdom.....	292,568	5,921,525	1870
Belgium.....	Kingdom.....	11,872	5,021,886	1869
Portugal.....	Kingdom.....	85,818	4,860,974	1868
Holland (with Luxemburg).....	Kingdom.....	13,678	3,885,841	1871
Denmark.....	Kingdom.....	55,021	1,864,496	1870
<b>States of the third rank.</b>				
Switzerland.....	Republic.....	15,991	2,669,147	1870
Greece.....	Kingdom.....	19,358	1,457,594	1870
<b>States of the fourth rank.</b>				
Roumania (under Turkish suzerainty).....	Principality.....	46,708	4,500,000	estimated.
Andorra.....	Republic.....	148	12,000	estimated.
Liechtenstein.....	Principality.....	62	8,320	1867
San Marino.....	Republic.....	22	7,308	1869
Monaco.....	Principality.....	6	3,127	1867

The present political systems of Europe are the product of nearly 20 centuries of strife and war among the different races inhabiting the continent. Though at certain periods

of peace political philosophers and statesmen have endeavored to demonstrate the existence of a certain balance of power, which, by keeping in check the ambition of conquerors, should serve as a guarantee for the continuance of the actual state of things, there

\* Including the Canary Islands.

† Including the Azores and Madelra.

are in the whole history of Europe scarcely any two succeeding generations during which this idea has been realized. There has always been an almost continuous shifting of boundaries irrespective of nationalities, and there is not one of the great powers that does not hold in subjection portions of other nationalities.—According to Kolb (*Handbuch der vergleichenden Statistik*, 1871), the yearly revenue of all the European states is \$1,712,000,000, of which sum \$764,000,000 belongs to the Teutonic states, \$579,000,000 to the Latin or Romanic states, \$292,000,000 to Russia, \$73,000,000 to Turkey and its dependencies, and \$4,380,000 to Greece. The average of revenue is: in Great Britain \$9 71 per head, in France \$8 73, in Austria \$5 26, in Germany \$4 08, in Switzerland \$4 12 (the lowest proportion in all Europe). The public debt of all European states amounted before 1850 to \$9,264,240,000, of which sum over \$6,000,000,000 was the public debt of the five great powers. But since then the extraordinary expenditure caused by the Crimean war of 1854-'6, the Franco-Sardinian war against Austria in 1859, the German-Italian war of 1866, and the Franco-Prussian war of 1870-'71, has increased the debt to near \$17,136,000,000. The paper currency of Europe amounted about 1850 to \$846,000,000, but within the last 20 years it has been so largely increased that its aggregate amount undoubtedly considerably exceeds \$1,000,000,000. The amount of coin was approximately stated at \$1,700,000,000 in 1850.—The military establishments of Europe include in time of peace about 2,500,000 men, kept at an expense of more than \$580,000,000. The proportion of the principal powers is: Germany, 420,000; Austria, 280,000; Great Britain (including the army in India), 250,000; France, 400,000; Russia, 600,000; Italy, 200,000; Spain, 200,000; Turkey and dependencies, 160,000. The navies of Europe consist of over 3,000 vessels, carrying over 30,000 guns, with 200,000 men, at a yearly expenditure of over \$125,000,000.

**EUROTAS**, the ancient name of a river of Greece, in Laconia, which rises in the mountains on the borders of Arcadia, about lat. 37° 15' N., lon. 22° 15' E., and, pursuing a general S. E. course, between the mountain ranges of Taygetus (now Pentadactylo) and Parnon (Malevo), empties into the gulf of Laconia. Its only tributary of consequence is the *Enus* (Kelesina), which joins it about a mile above the site of ancient Sparta. The Spartans rendered to the Eurotas divine honors. In modern times it has borne the names of Iri and Vasili.

**EURYDICE**. I. In Greek mythology, the wife of Orpheus. She died from the bite of a serpent, and her husband followed her into the infernal regions, where Pluto, charmed by the lyre of Orpheus, gave him permission to take her back to earth, on condition that he would not look behind him while ascending. But, overcome by love or doubt, he glanced back at

her as they were about to pass the bounds of Hades, and saw her disappearing. (See *ORPHEUS*.) II. The daughter of Amyntas, son of Perdiccas III., king of Macedon, and of Cynane, daughter of Philip. On the death of Antipater in 319 B. C., she assembled an army and advanced against Polysperchon, who had succeeded him as regent. The presence of Olympias, the mother of Alexander, with the army of the latter, decided the contest against Eurydice, who was captured and thrown into prison, where she hanged herself.—Several others of the name are mentioned in ancient history.

**EUSEBIUS**, surnamed *ΠΑΜΦΙΛΙ*, an ecclesiastical writer of the early church, born in Palestine about 265, died about 340. But little is known of his youth, save that he began his studies in Antioch, then visited the Thebaid, where he spent some time in completing his knowledge of Scripture and theology, after which he opened a school at Cæsarea. A splendid library founded or much enlarged by the bishop Pamphilus, his protector, enabled Eusebius to collect vast treasures of erudition. In the persecution of Diocletian (303) he fled from the city, but soon returned for the purpose of ministering to the wants of Pamphilus, who had been cast into prison, and was in 309 put to death. Eusebius assumed his name in memory of their friendship. Paulinus, bishop of Tyre, next gave him an asylum, but persecution drove him into Egypt, where he suffered imprisonment until the abdication of Diocletian set him free, and allowed him to return to Cæsarea, of whose church he became bishop in 315. About this time some points of resemblance between his theological views on the Trinity and those of the heresiarch Arius caused him to contract a friendship for the latter. At the council of Nice he sat at Constantine's right hand, and made the first draft of the Nicene creed. He subscribed the solemn profession of faith in the divinity of the Son, with a reservation founded on a confusion of the eternal birth of the Logos with the temporal birth of the incarnate Word, but he refused peremptorily to subscribe the decrees condemnatory of the Arian doctrine. A letter which he addressed to his diocesan after the council in explanation of his position and his views, together with his unremitting exertions in favor of Arius, caused him to be accused of heresy. His formulas and terminology continued to be employed by the Semi-Arians long after he had himself given expression to more orthodox opinions in his work *De Ecclesiastica Theologia*. In the long Arian controversies subsequent to the council of Nice he was the uncompromising opponent of Athanasius. He prevailed on the emperor to convene a council in 331 in Cæsarea, before which Athanasius was summoned, but refused to appear, and was accused by Eusebius of disobedience to the laws of the empire. His influence with Constantine caused a second council to be assembled in Tyre in 335, in which

he urged and obtained the deposition of Athanasius, and afterward procured his banishment to Gaul. On Sept. 14, 335, the bishops who had composed the council of Tyre assembled in Jerusalem for the dedication of a new church. Eusebius pronounced on the occasion his "Panegyric of Constantine," caused Arius to be admitted to the communion of the church, and wrote to the bishops of Christendom to inform them of these proceedings. Shortly after this the same prelates met in Constantinople under the leadership of Eusebius, who had Marcellus, bishop of Ancyra, condemned for Sabellianism, and besought in vain Alexander, bishop of the imperial city, to receive Arius solemnly to his communion. After witnessing the tragic death of Arius on this occasion, Eusebius returned to Cæsarea, and continued until his death with equal assiduity the publication of his great works and his opposition to Athanasius. He has been justly called the father of ecclesiastical history. Theological writers, both ancient and modern, are much divided with regard to his orthodoxy; some, like the historians Sozomen and Socrates, defend him strenuously; while others, with St. Jerome, Photius, and the seventh general council, condemn him as a heretic. His principal works are: "A Defence of Origen," in six books, in the first five of which the bishop Pamphilus cooperated; "Evangelical Preparation," in 15 books, and the "Evangelical Demonstration," in 20; *Chronicon*, a conspectus of universal history down to the 20th year of Constantine; "Ecclesiastical History;" a "Life of Constantine;" five books "On the Incarnation;" "Commentaries on Isaiah;" *Onomasticon*, or a nomenclature of nations according to the Hebrew books; 30 books "Against Porphyrius;" "Topics;" "Topography of Judea and the Temple;" "Commentaries on the Psalms;" "Concordance of the Four Gospels;" "Commentary on the First Epistle to the Corinthians;" and "Treatise on the Fulfillment of Christ's Prophecies." His *Chronicon* was translated into Latin by St. Jerome, who continued it down to the sixth consulate of Valens and Valentinian; and it was published by Scaliger (2 vols. fol., Amsterdam, 1658). The whole work was in a fragmentary state until the discovery in 1784 of an Armenian version, which was published by Mai and Zohrab in 1818, and explained afterward by Niebuhr. His "Ecclesiastical History" was continued by Sozomen, Socrates, and Theodoret, and translated by Rufinus into Latin, and brought down to 395 (Rome, 1474). The principal editions are those of Stephens (Paris, 1544), Valois (Paris, 1659), Reading (Cambridge, 1720), Heinichen (3 vols. 8vo, Leipsic, 1827), and Burton (Oxford, 1838; reprinted, with an introduction by W. Bright, Oxford, 1872). It has been translated into French by Louis Cousin; into German by Hedio (1545) and Stroth (1778); and into English by Hanmer (1577), Parker (1703),

Cater (1736), Dalrymple (1778), and Crusé (reprinted in Bohn's "Ecclesiastical Library"). A Greek edition (with Latin translation) of the complete works of Eusebius is contained in Migne's *Patrologia Græca* (Paris, 1857-'66, vols. xix. to xxiv.). The best Latin edition of the works then extant is that of Paris, 1581.

**EUSTACHI**, or **Eustachio**, **Bartolommeo** (Lat. **Eustrachius**), an Italian anatomist, born probably at San Severino, near Salerno, died in Rome in 1574. He was a contemporary of Vesalius, and shares with him the merit of laying the foundation of the science of human anatomy. He extended the knowledge of the internal ear by giving a correct description of the tube between the throat and the ear, which has been called after him the Eustachian tube. He was also the pioneer in the accurate study of the anatomy of the teeth. His *Tabule Anatomica*, the text to which seems to have been lost, were first published in 1714 by Lancisi. Eustachi, who was professor of anatomy and physician to the cardinals Borromeo and Rovero, seems to have been so poor that he was unable to publish his works. Lauth remarks that if he had been able to publish them, anatomy would have attained the perfection of the 18th century 200 years earlier at least. A new edition of the *Tabule* was published by Albinus with an excellent commentary (Leyden, 1743). A Dutch commentary by Bonn appeared in Amsterdam in 1798; and one in German by Kraus in the same city in 1800.

**EUSTIS**, **William**, an American physician and politician, born in Cambridge, Mass., June 10, 1753, died in Boston, Feb. 6, 1825. He graduated at Harvard college in 1772, and subsequently studied medicine. He entered the American army during the revolutionary contest as a regimental surgeon, and served throughout the war in that capacity, or as hospital surgeon, being for some years stationed at the house opposite West Point in which Arnold had his headquarters. Upon the conclusion of the war he practised in Boston. Between 1800 and 1805 he was a representative in congress, and in 1809 he was appointed by President Madison secretary of war, a position which he retained until the surrender of the American forces under Gen. Hull to the British in 1812, when he was compelled to resign. In 1814 he was appointed minister to Holland, and after his return served again in congress between 1820 and 1823. In the latter year he was elected governor of Massachusetts, and died while holding that office.

**EUTAW SPRINGS**, a small affluent of the Santee river, in South Carolina, about 50 m. N. W. of Charleston, near which was fought, Sept. 8, 1781, a battle between the Americans under Gen. Greene and the British under Col. Stuart. The American force was about 2,000, that of the British about 2,300. Four miles from Eutaw a reconnoitering detachment of British cavalry was put to flight after a severe



skirmish. One mile from the British camp a body of infantry was encountered, which soon fell back. The action became general soon after 9 o'clock, and after a sharp contest the British were driven from their camp. The American soldiers had scattered among the tents of the enemy, plundering and drinking, when Stuart suddenly renewed the battle. Greene withdrew his troops out of range, deciding, as the enemy could maintain themselves but a short time, to wait and attack them on their retreat. During the night the British retreated toward Charleston; and the next day Greene advanced and took possession of the battle field, and sent detachments in pursuit of them. The British lost 133 killed and wounded, and 500 prisoners. The American loss was 535 in killed, wounded, and missing.

**EUTERPE** (Gr. *εὐ*, well, and *τέρπειν*, to delight), the inspirer of delight, one of the nine muses, daughter of Zeus and Mnemosyne (memory). She presided over lyric poetry, and played on the flute, of which she was the inventor; according to some, she also invented tragedy, which is more generally attributed to her sister Melpomene. She is usually represented as a virgin, crowned with flowers, with a flute in her hand, or various musical instruments around her, and sometimes as dancing.

**EUTYCHES**, a heresiarch of the 5th century, born about 380, died about 454. For many years he lived as a priest and archimandrite in the cloisters of Constantinople, where he had more than 300 monks under his direction. He was the head of the party opposed to Nestorius, who, in order not to confound the divine and human natures in Christ, had affirmed that there were in him two distinct persons. Eutyches, in his zeal for singleness of person in Christ, was led to maintain also that he possessed but one nature; whence his followers were called Monophysites. This opinion became popular in the Alexandrian church, where the doctrines of Nestorius had been most loudly condemned. The rising heresy was examined and condemned by a synod at Constantinople in 448. The influence of Eutyches and his friends obtained from Theodosius II. the reference of the matter to a general council to meet at Ephesus in 449 under the presidency of Dioscorus, a violent Eutychian. Here the triumph of Eutyches was secured by the outcries of monks, the threats of soldiers, and the overbearing violence of the president; and the most prominent hostile bishops were deposed. Pope Leo refused to recognize the acts of this council, which was known as the Latrocinium, or robber synod, and excommunicated Dioscorus; and at the general council of Chalcedon, in 451, both the doctrines of Nestorius and of Eutyches were condemned. In the 6th century a great revival of the doctrine took place under the auspices of the monk Jacob Baradaeus, who died bishop of Edessa. From him the sect took the name of Jacobites, who still constitute a numerous church in Egypt,

Syria, and Abyssinia. The emperor Heraclius sought to mediate between the Monophysites and Catholics, and promulgated a decree in 630, requiring the doctrine to be taught that there were two natures in Christ, but only a single will. Hence the name of Monothelites, the last offshoot of the heresy of Eutyches.

**EUXINE SEA.** See BLACK SEA.

**EVAGORAS**, king of Salamis in Cyprus, died about 374 B. C. His family claimed descent from Teucer, the reputed founder of Salamis, and had long held the sovereignty of that city, till expelled by a Phœnician exile. Evagoras recovered the kingdom in 410, and endeavored to restore in it the Hellenic customs and civilization, which had almost disappeared under the long domination of barbarians. He gave a friendly reception to the Athenian general Conon, after the defeat at Ægospotamos; it was by his intercession that the king of Persia permitted the Phœnician fleet to aid Conon; and he himself commanded the Cypriote squadron which joined Conon and Pharnabazus at the battle of Cnidus (394). For these services a statue was erected to him at Athens in the Ceramicus, by the side of that of Conon. His increasing power attracted the jealousy of the Persian king Artaxerxes II., who declared war against him. Evagoras immediately extended his power over almost the whole of Cyprus, ravaged the coasts of Phœnicia, excited the Cilicians to revolt, and even captured the city of Tyre; but a Persian army, landing in Cyprus, recaptured the island and besieged Evagoras in his capital. He was saved only by the dissensions of his enemies, and concluded in 385 a peace by which the sovereignty of Salamis was secured to him. He survived this treaty ten years, and died by assassination.

**EVAGRIUS**, a Syrian church historian, born about 536, died in Constantinople, probably early in the 7th century. He was an eminent lawyer in Antioch, but devoted much of his time to scholastic labors, and wrote in Greek an ecclesiastical history, in continuation of previous works by other authors, extending from 431 to 593, which is recognized as a high authority. The best edition is by Reading (3 vols., Cambridge, 1720). Meredith Hanmer furnished an English translation with a biography of Evagrius to Bagster's "Ecclesiastical Historians," subsequently included in Bohn's "Ecclesiastical Library" (London, 1851).

**EVALD**, or **Ewald, Johannes**, a Danish poet, born in Copenhagen, Nov. 13, 1743, died there, March 17, 1781. He early displayed his love of adventure by an attempt to go to sea, and afterward entered the army of Frederick the Great, which he immediately abandoned, joining that of Austria; but he was induced to return to Copenhagen, where he studied theology, and passed his examination in 1762. Disappointed in love, he devoted himself to literature. His first composition, "The Temple of Fortune, a Vision," was followed in 1766 by a poem on the death of Frederick

V. In 1769 appeared his lyrical drama of "Adam and Eve." His tragedy of *Rolf Krage* (1770) was the first attempt to dramatize the ancient history of Denmark, and bears evidence of the careful study of both Ossian and Shakespeare. About this time he became lame, and poverty, neglect, and intemperance added to his misfortunes. He was eventually deserted even by his mother, and the last two years of his life were spent in the house of a benevolent friend. But his literary activity remained undiminished, and in 1771 and 1772, while in the greatest distress of mind and body, he wrote even humorous plays, which were very successful. His most celebrated work, *Balders Död* ("Baldur's Death"), a drama devoted to the heroic reminiscences of Scandinavian mythology, appeared in 1773. His finest lyrical poem, "The Fishermen," appeared in 1778. He also wrote a famous national song of Denmark, and some works in prose. He began to prepare his poetical works for publication, but the edition was completed only after his death (4 vols., Copenhagen, 1781-'91; best ed., by Liebenberg, 8 vols., 1850-'55).

**EVANGELICAL ALLIANCE**, a religious association among different denominations of Protestants in Europe and America. A convention, called for the formation of such an alliance, met in Freemason's hall, London, England, Aug. 19, 1846. It consisted of about 800 clergymen and laymen from France, Belgium, Germany, Switzerland, Italy, Turkey, Great Britain and Ireland, the United States, and Canada, representing 50 denominational connections. The convention sat 13 days, and adopted the basis of the religious doctrines held in common by evangelical Protestants, viz.: the inspiration and sufficiency of the Scriptures; the right of private judgment in interpreting the Scriptures; the unity and trinity of the Godhead; human depravity; the incarnation and atonement of Christ; justification by faith alone; conversion; eternal rewards and punishments; the divine institution of the ministry, and of baptism and the Lord's supper. It was declared that this summary of doctrines was not to be regarded in any formal or ecclesiastical sense as a creed or confession, nor its adoption as an assumption of the right to define the limits of Christian brotherhood, or that the doctrines adopted embrace the whole of important truth. The convention recommended the formation of national branches in the different countries of Europe and America; the object of the association being to display the substantial union of Protestants of different countries and names, and to strengthen and enlarge that union. The recommendation was followed by the formation of coördinate societies, independent of each other, but united in object and sympathy, in Great Britain and Ireland, France, Germany, Holland, Switzerland, Sweden, America, and among the missionaries in Turkey, Persia, the East and West

Indies, Palestine, Australia, New Zealand, and Africa. Besides the convention in which the alliance was formed, six international conferences have been held at irregular intervals: in London, 1851; Paris, 1855; Berlin, 1857; Geneva, 1861; Amsterdam, 1867; and New York, 1873. These conferences have been largely attended, the last (Oct. 2-12, 1873) especially so, and have embraced many of the most distinguished members of the respective denominations, both of the clergy and laity. Besides the regular sessions of the conferences, during their progress special meetings have been held with reference to particular countries, in which the languages of these countries were used, and their wants brought before the Christian world. At the Geneva conference in 1861 a special meeting was held with reference to the civil war in America, for the purpose of bringing the true aspects of the war before European Christians. The alliance has for several years united, through its committees, in recommending a time and subjects for special prayer, which have been generally observed by those in sympathy with the alliance throughout the world; the first week in January being the time selected, and the subjects for each day of the week being considered in all lands. The alliance has exerted an influence in favor of religious liberty in Spain, Italy, Austria, Sweden, and Turkey; and in 1871 a committee representing different branches in Europe and America proceeded to Russia, and memorialized the czar in behalf of the Protestants in the Baltic provinces.—Reports of the proceedings of the several conferences have been published under the following titles: "The Religious Condition of Christendom" (London, 1852); "The Religious Condition of Christendom" (London, 1859); "The Geneva Conference of the Evangelical Alliance" (Edinburgh and London, 1862); and *Evangelische Alliantie* (Rotterdam, 1867), and "Proceedings of the Amsterdam Conference" (London, 1868).

**EVANGELICAL ASSOCIATION**, an ecclesiastical body, sometimes erroneously called the German Methodist church, probably because its confession of faith and its polity are very similar to that of the Methodist Episcopal church, while its members are chiefly Germans or of German descent. It took its rise in the eastern part of Pennsylvania in the year 1800, and resulted from an organization into classes and congregations of the disciples of the Rev. Jacob Albright, who, being impressed by the general decline of religious life, and the corruption of doctrines and morals that prevailed in the German churches in that portion of the country, undertook about 1790 to work a reform among them. The effect of his first efforts encouraged him to travel through a great part of the country, preaching in churches, in schools or private houses, in the public roads, &c. He soon found it necessary to unite his converts, scattered over several counties, into small societies for mutual support and sympa-

thy. At a meeting called for the purpose of consulting upon the best measures to be adopted, the assembly unanimously elected Mr. Albright as their pastor, authorizing him to exercise all the functions of the ministerial office over them, and declared the Bible to be their rule of faith and practice. This organization was soon after considerably improved by the adoption of a creed and rules for church government. In the course of time annual conferences were held; and in 1816 a general conference met for the first time in Union co., Pa., which consisted of all the elders in the ministry. Since 1843 a general conference, composed of delegates elected by the annual conference from among their elders, has held quadrennial sessions. This body constitutes at once the highest legislative and judicial authority recognized in the church. The ministry is divided into two orders, deacons and elders; and, faithful to the principles and example of their founder, they practise itinerancy. Its highest permanent order is the eldership; for, although the society has its bishops and presiding elders, yet these, to be continued, must be reelected every four years; and if not reelected, they hold no higher rank or privilege than that of an elder. For the first 25 years of its existence the society struggled against violent opposition, but since then it has made rapid progress, so that in 1873 it comprised 15 annual conferences, consisting of over 600 itinerant and 400 local preachers. The church has hardly any congregations in the New England and the southern states, and is most numerous in Pennsylvania and the northwestern states. It has two conferences outside of the United States, Canada and Germany, both established in 1863. The aggregate membership in 1873 was 83,195, an increase over the preceding year of 2,505. The membership of the Canada and Germany conferences was about 8,500. The institutions of learning sustained by the church in 1872 were, the Northwestern college in Naperville, Ill.; the Union seminary in New Berlin, Pa.; the Blairstown seminary in Blairstown, Md.; and the Ebenezer orphan institution at Flatrock, Ohio. Its publishing house at Cleveland, Ohio, issues six periodicals, three in German and three in English, besides which two periodicals are published in Germany. The society forbids its ministers and members the use of intoxicating liquors as a beverage, and refuses church fellowship to manufacturers and vendors of them. In theology it is Arminian, but holds the essential doctrines of the gospel as they are held in common by the various evangelical churches, with all of whom it aims to cultivate a fraternal spirit. The first volume of a "History of the Evangelical Association" has been published by the Rev. W. W. Orwig.

**EVANGELIST** (Gr. *εὐ*, well, and *αγγελειν*, to announce), one who brings good tidings. Hence the writers of the four Gospels are called the evangelists, because they in a preëminent sense

declare the glad tidings of salvation by Christ. Evangelists were early designated as a particular class of religious teachers in the Christian church, next in order to the apostles, and under their direction; not attached to any particular church or place, but going forth to preach the gospel wherever they were called or sent, and to travel among the infant churches, ordain their ordinary officers, and finish the work the apostles had begun. The primitive order of evangelists, distinct from other public religious teachers, is supposed to have been merely temporary, like that of apostles and prophets; but the class of duties and services which they performed seems to have fallen more especially on the missionaries of modern days.

**EVANS, Sir De Lacy**, a British general, born at Moig, Ireland, in 1787, died in London, Jan. 9, 1870. Entering the army as an ensign, he served three years in India, and subsequently distinguished himself in Portugal and Spain in the campaigns of 1812-14. He served in America as a brevet lieutenant colonel, was at the battle of Bladensburg, Aug. 24, 1814, and at the head of 100 men, acting under orders from Gen. Ross, forced the capitol at Washington. Of this expedition he wrote an account, "Facts relating to the Capture of Washington," &c. (8vo, London, 1829). He also took part in the attack on Baltimore. In December, 1814, and again in January, 1815, he was wounded before New Orleans, and was sent home. He recovered in time to join Wellington at Quatre Bras and Waterloo, and was at the subsequent investment and capitulation of Paris. In 1828 he published a pamphlet "On the Designs of Russia" in the East, which excited much attention, and was translated and published in Paris. In 1830 he was for a few months a member of parliament for Rye, and was reelected in 1831. From 1833 to 1841 he represented Westminster. In 1835 he commanded the British auxiliary legion of 10,000 men in aid of the queen of Spain against Don Carlos. He was in Spain till the spring of 1837, and for his exploits at Bilbao, San Sebastian, and Irun he was made a knight commander of the bath, and received the cross of San Fernando and San Carlos. In 1846 he was reelected to parliament for Westminster, and retained this seat till 1865. In the Crimean war, as lieutenant general, he commanded the second division of the British army, and for his services at the Alma and at Inkerman he received the thanks of parliament, and the grand cross of the bath, and was made a grand officer of the legion of honor.

**EVANS, Edward P.**, an American scholar and author, born at Remsen, N. Y., Dec. 8, 1833. His father was a Welsh Presbyterian clergyman, who emigrated to the west in 1842. Edward graduated at the university of Michigan in 1854, taught an academy in Hernando, Miss., one year, and then became professor in Carroll college, Waukesha, Wis. From 1858 to 1862 he travelled in Europe, and studied

in the universities of Göttingen, Berlin, and Munich. In the autumn of 1862 he became professor of modern languages in the university of Michigan, which position he resigned in 1870 to travel in Europe and collect materials for a history of German literature. He has published translations of Stahr's life of Lessing (2 vols., Boston, 1866) and Coquerel's "First Historical Transformations of Christianity" (Boston, 1867); *Abriss der deutschen Literaturgeschichte* (New York, 1869); and various philosophical articles in periodicals.

**EVANS, Frederick William**, presiding elder of the community of Shakers at New Lebanon, Columbia co., N. Y., born in Leominster, England, June 9, 1808. His father settled in the United States in 1820, and apprenticed him to a hatter in New York. He was a diligent student in his leisure hours, was attracted by the theories of Owen and Fourier, and after a brief visit to England joined the Shaker community, whose leader he became in the United States. He has published "Tests of Divine Revelation," "Anne Lee, or Shakers and Shakerism," "Compendium," "Autobiography of a Shaker," and "Religious Communism."

**EVANS, Lewis**, an American geographer and surveyor, born about 1790, died in June, 1756. During an active professional life he collected many materials for a map of the British North American colonies, and in 1749 published one of the middle colonies, chiefly of New York, New Jersey, and Delaware, and of the Indian country adjacent. A second edition appeared in 1755, much enlarged, and containing in addition Virginia, Maryland, Pennsylvania, and a part of New England. He also published "Geographical, Historical, Political, Philosophical, and Mechanical Essays" (No. 1, Philadelphia, 1755; No. 2, London, 1756). A new edition of his map appeared in 1776.

**EVANS, Marian.** See LEWES, MARIAN EVANS.

**EVANS, Oliver**, an American inventor, born in Newport, Del., in 1755, died in New York, April 21, 1819. He was apprenticed to a wheelwright, and before he had reached the age of manhood the construction of a land carriage to be propelled without animal power began to occupy his attention. At the age of 22 he invented a machine for making card teeth which superseded the old method of manufacturing them by hand. Two years later he entered into business with his brothers, who were millers, and in a short time invented the elevator, the conveyor, the drill, the hopper-boy, and the descender, the application of which to mills worked by water power effected a revolution in the manufacture of flour. In 1786-'7 he obtained from the legislatures of Maryland and Pennsylvania the exclusive right to use his improvements in flour mills, and Maryland also gave him a similar privilege with respect to steam carriages. It was not till 1799 or 1800 that he was able to set about the construction of a steam carriage; but finding that his steam engine differed in form as well

as in principle from those in use, it occurred to him that it could be patented and applied to mills more profitably than to carriages; and in this he was completely successful. This was the first steam engine constructed on the high-pressure principle; and to Evans, who had conceived the idea of it in early life, and in 1787 and again in 1794-'5 had sent to England drawings and specifications, the merit of the invention belongs, although it has been common to assign it to Vivian and Trevithick, who had had access to Evans's plans. In 1803-'4, by order of the board of health of Philadelphia, he constructed the first steam dredging machine used in America, consisting of a flat scow with a small engine to work the machinery for raising the mud. The machine, which he named the "Orukter Amphibolos," propelled itself on wheels to the Schuylkill, a distance of  $1\frac{1}{2}$  m., was fitted with a paddle wheel in the stern, and navigated the river to its junction with the Delaware. This is believed to have been the first instance in America of the application of steam power to the propelling of land carriages. He predicted the time when such carriages would be propelled on railways of wood or iron, and urged the construction of a railroad between Philadelphia and New York, but was always prevented by his limited means from prosecuting his mechanical experiments to the extent he desired. He was the author of "The Young Engineer's Guide" (8vo, Philadelphia, 1805; translated into French, Paris, 1821-'5 and 1838), and "Miller and Millwright's Guide" (8vo, Philadelphia, 1797, 1807, 1818; and 8vo, Paris, 1830; 14th ed., with additions and corrections by Thomas P. Jones, and a description of an improved merchant flour mill by C. and O. Evans, 8vo, Philadelphia, 1838).

**EVANSTON**, a township of Cook co., Illinois, on Lake Michigan and on the Chicago and Northwestern railroad, 12 m. N. of Chicago; pop. in 1870, 3,062. It is the seat of three Methodist educational institutions, viz.: the Northwestern university, organized in 1854, and having in 1872 11 professors and instructors, 452 students, and a library of 22,000 volumes; the Garrett Biblical institute, established in 1856, which in 1872 had 6 professors, 64 students, a library of 3,000 volumes, and an endowment of \$424,000; and the Evanston college for ladies, organized in 1871, having 12 instructors and 250 students.

**EVANSVILLE**, a city, port of entry, and the capital of Vanderburg co., Indiana, 144 m. S. S. W. of Indianapolis, built on high ground on the N. bank of the Ohio river, nearly 200 m. from its mouth and the same distance below Louisville, Ky.; pop. in 1850, 3,235; in 1860, 11,484; in 1870, 21,830, of whom 6,276 were foreigners and 1,427 colored. The river at this point describes a half-moon, whence Evansville is sometimes called the "crescent city." In the vicinity are found coal and iron ore. The city contains a handsome court house, city hall,

United States marine hospital, an opera house, and several hotels. The United States government is also erecting a large building to accommodate the post office, United States courts, and the custom house. The Wabash and Erie canal extends to Toledo, Ohio, a length of 462 m.; the Evansville and Crawfordsville railroad connects, *via* Terre Haute, with the principal railroads of the state; and the St. Louis and Southeastern railroad affords communication with that city. The Lake Erie, Evansville, and Southwestern railroad is completed to Boonville, the county seat of Warrick co. Evansville is a place of great commercial activity, and its manufactures are important. In 1871 the number of arrivals and departures of vessels was 2,586; value of imports, \$169,588 30, the principal items being railroad iron, hardware, and coffee; amount of duties collected, \$69,771 72. The principal articles of export are grain and flour, pork, salt, whiskey, cement and lime, cotton, hay, dried fruit, tobacco, and railroad iron. For the year ending June 30, 1872, there were 70 vessels of 10,047 tons belonging to the port, of which 56 of 9,046 tons were steamboats, and 14 of 1,001 tons canal boats; built during the year, 8 steamboats of 721 tons. The total value of manufactures in 1872 was \$5,469,763, consisting of furniture, flour and meal, machinery, planing mill products, stoves and hollow ware, malt liquors, saddlery and harness, clothing, leather, marble and dressed stone, cotton goods, cooperage, tinware, brick, &c. There are four national banks, with an aggregate capital of \$1,950,000. The city is divided into twelve wards. Terms of the United States circuit and district courts are held here. The assessed value of property in 1851 was \$1,907,632; in 1861, \$5,385,675; in 1871, \$20,528,075; taxation in 1871, \$265,945. There are nine large public school buildings belonging to the city, the high school building being the finest in the state. The number of separate departments in 1872 was 49, viz.: a high school, 8 grammar, and 40 primary, having 73 teachers and 4,583 pupils. The library association has 3,500 volumes. There are four daily newspapers (two German), one tri-weekly, five weekly, and one semi-monthly. There are 24 churches, viz.: 4 Baptist, 1 Christian, 2 Episcopal, 1 Evangelical German, 3 Lutheran, 6 Methodist, 4 Presbyterian, and 3 Roman Catholic. Evansville was laid out in 1817.

**EVAPORATION**, the dissipation of bodies by the volatile particles at their surface assuming the form of vapors and disappearing in the space around them. Liquids manifest this property most sensibly. Mercury exhibits it at temperatures exceeding 60° F., as is shown by the invisible fumes forming an amalgam on the surface of a bit of gold leaf, suspended for some days over the surface of the metal; and at temperatures far below this limit the vapor of mercury is present in the vacuum of the upper portions of the tubes of barometers and thermometers. Many solid bodies are subject to

it; camphor, ice, snow, musk, &c., waste away by their particles being taken in invisible vapor into the surrounding atmosphere. It is a part of the process provided by nature for restoring to the earth, through the medium of the clouds, the waters which have drained from its surface into the sea, and those also held in the soil, or upon the leaves of the forest. Once having performed their office, they are recalled by the process of evaporation, purified by it of their earthy contaminations, and are again poured out for the refreshment of vegetable and animal life. (See **ATMOSPHERE**, **DEW**, **HEAT**, and **ICE**.) The following table gives some relations between the vapor of water and the liquid:

Temperature, Fahrenheit.	Volume of vapor containing a unit of water.	Mechanical force required to vaporize, in foot pounds.
-4°	650,588	1,895
+32	182,323	1,453
50	102,070	1,505
100	22,513	1,722
140	7,937	1,847
212	1,696	2,073
250	896	2,192

Evaporation takes place in ordinary temperatures only from the surface of objects. It is greater in a warm dry air than when the temperature is low, or the atmosphere is already nearly filled with vapor. The more moisture is taken up into the same body of air, the more the process is retarded, until at length it is entirely checked. It is renewed by new supplies of dry air. The most favorable natural conditions for its rapid action are presented on the Atlantic ocean under the trade winds, which from the hot deserts of Africa blow across to the Cordilleras. The Amazon and the Orinoco are the fruits of the evaporation thus produced. The vapors that are continually ascending from moist surfaces are for the most part invisible, like those exhaled by breathing. Their existence is proved by instruments called hygrometers, hygrometers, and psychrometers; and at times they become visible, as when in clear frosty weather they rise copiously from the surface of pools fed by deep springs, and are seen congealed in white clouds, like the vapors of the breath under the same conditions. But unless deprived of their heat they possess the properties of gaseous bodies; a given bulk of air or of other gases takes up the same quantity of a vapor as would be received in a vacant space of the same extent and temperature. This was conclusively proved from the experiments of Dr. Dalton. It results that no more vapor can be received into any space after the weight of that already there amounts to the elastic force of the vapor at the temperature of the surface which generates it; in proportion as the air approaches this state of complete saturation it is said to be more moist, and evaporation proceeds more slowly. Increase of temperature adds to the elasticity of the vapor and promotes evaporation; cold reduces

the elasticity and promotes precipitation. Pressure does not affect the capacity of air to contain vapor; but evaporation proceeds more slowly by its increase. If it be removed, as when a liquid is placed in an exhausted receiver of an air pump, evaporation goes on with great rapidity. Ether may thus at ordinary temperatures be thrown into ebullition. A difference is observed in the tendency of different liquids to pass into vapor; the lower their boiling point, the more rapid is their evaporation; but it is also observed that the vapor thus easily produced is correspondingly less rare, occupying less space than that requiring a greater expenditure of heat for its evolution. The density of alcoholic vapor is 2.5 times greater than that of water. Dalton discovered that the presence of air or any gas impeded evaporation by the resistance its particles opposed to the circulation of the vapor; but whether any gas were present or not, the same amount of vapor would always be formed at the same temperature. The effect of the air was seen in the longer time required to fill the space with the amount of vapor belonging to the temperature. Vapors have a greater capacity for heat than their particles when condensed into liquid or solid form. In their formation consequently they abstract heat from surrounding bodies, producing an amount of cold corresponding to the rapidity of the process. This principle is applied in the water and wine coolers used in hot countries. The water with which they are filled, and in which the wine bottles are placed, filters through the porous vessels and evaporates from their surface, cooling all the contents. A similar effect is experienced in the animal body by rapid evaporation. The heat generated by the chemical actions going on within is taken off by the vapor formed at the surface. Damp clothes furnish the means for the production of much vapor and consequent reduction of temperature, often to an injurious extent. The heat abstracted by vapor in its formation is given out on its condensation. In low pressure steam engines it is economized by being transferred in the condensers to the water that is returned to the boilers.—Hygrometers and hygrometers, already referred to, are instruments designed, the first for detecting the presence of moisture in the atmosphere, and the second for determining either the temperature at which the air under observation begins to shed its moisture, called the dew point, or else the temperature of evaporation. Either of these and the normal temperature of the air being known, the elastic tension of the atmospheric vapor, and the amount of moisture in a given quantity, are approximately ascertained by reference to tables constructed for this purpose. (See DEW POINT, and HYGROMETER.) Evaporation is accompanied with ebullition when the elastic force pressing upon the surface of a liquid is less than that due to the temperature of this liquid. (See BOILING POINT.)—The principles devel-

oped by researches in the evaporation of liquids have been applied in a variety of ways to facilitate and render more economical several practical operations. Sirups are evaporated, as in the refining of sugar, in vacuum pans, or vessels in which the atmospheric pressure may be partially taken off by air pumps. A low degree of heat only is thus required, and the risk of overheating and burning the sirup is avoided. Extracts are conveniently prepared on the same principle. But when it is desirable to effect the boiling at high temperatures, as for digesting bones and subjects difficult to dissolve, the evaporation is prevented by the vapor being confined, so as to exert its elastic force upon the surface of the fluid. Thus the escape of more steam is checked until, by greater heat, its elastic force is made greater than that upon the surface. By this method the temperature of the water has been raised to more than 400° F. Rapid evaporation has been promoted in salt works and in bleacheries by causing currents of air to blow over the extended surfaces of the liquids, thus constantly bringing new portions of dry air to absorb fresh quantities of moisture.—As evaporation cannot take place unless the elasticity of the vapor can overcome the superficial tension of the liquid, and as this tension depends to a large extent on the nature of the gas in contact with the free surface of the liquid, it follows that the boiling point must vary with every circumstance. Thus Dufour, having dropped some pure water into a mixture of oils having nearly the same density, was able to raise the temperature to 356° F., and still saw drops of water swimming in the mixture, although the tension of the aqueous vapor at this temperature is about 147 lbs. to the square inch. When water falls upon red-hot surfaces it separates in spherical drops, which dance around upon the metal, apparently without touching it, and thus continue without evaporating much longer than the fluid would if exposed to the same degree of heat under other circumstances. A platinum crucible brought nearly to a white heat may be almost half filled with water introduced drop by drop, which will continue in this state for some minutes without perceptible evaporation. On cooling the crucible, the liquid suddenly begins to boil, and discharges a volume of vapor. While in the spheroidal state drops are seen to be supported on an atmosphere of vapor, which prevents their contact with the surface of the metal. Most liquids, except oils which are decomposed by the heat, display the same phenomena. Their temperature while in this condition is not only much less than that of the surface upon which they rest, but is also below their own boiling point; and if they are already boiling when dropped upon the heated surface, the temperature falls to a certain point, which appears to be a fixed one for each liquid in this condition. Water remains at 205°; alcohol, which boils at 173°, falls at least 3°; ether, which boils at 95°, falls at least 5°. The tem-

perature of the heated surface at which liquids are caused to assume this condition has been found, for water, to be 340° or more; for alcohol, 273°; and for ether, 140°. The check upon evaporation is very remarkable. A quantity of water which would ordinarily disappear in vapor in one minute at the temperature of 212°, has been kept from total dispersion nearly an hour in a metallic vessel heated nearly red.

**EVARTS, I. Jeremiah**, secretary of the American board of commissioners for foreign missions, born in Sunderland, Vt., Feb. 3, 1781, died in Charleston, S. C., May 10, 1831. He graduated at Yale college in 1802, and after some time spent in teaching, he studied law, was admitted to the bar in 1806, practised his profession in New Haven for about four years, and from 1810 to 1820 edited the "Panoplist," a religious monthly magazine published at Boston. In 1812 he was chosen treasurer of the American board of commissioners for foreign missions, and in 1820, when the "Panoplist" was discontinued, and the "Missionary Herald" was issued by the board in its stead, he took charge of the latter periodical. He was chosen corresponding secretary of the board in 1821, and retained that office until his death. He wrote 24 essays on the rights of the Indians, under the signature of "William Penn," which were published in 1829.—See "Memoirs of Jeremiah Evarts," by E. C. Tracy (8vo, Boston, 1845). **II. William Maxwell**, an American lawyer, son of the preceding, born in Boston, Feb. 6, 1818. He graduated at Yale college in 1837, studied in the Harvard law school, and was admitted to the bar in New York in 1841. He received the degree of LL. D. from Union college in 1857, from Yale in 1865, and from Harvard in 1870. In the impeachment trial of President Johnson, in the spring of 1868, Mr. Evarts was principal counsel for the defendant. From July 15, 1868, to the close of President Johnson's administration, he was attorney general of the United States. In 1872 he was counsel for the United States in the tribunal of arbitration on the Alabama claims at Geneva. Of Mr. Evarts's public addresses there have been published "Centennial Oration before the Linnæan Society of Yale College" (8vo, New Haven, 1853), and "Address before the New England Society" (8vo, New York, 1854).

**EVE** (Heb. *Havvah*), in Scriptural history, the name given by Adam to his wife. It is derived from the verb *'hayoh*, to live, and was applied to her as "the mother of all living." She was created to be a help meet for Adam, and was placed by God with him in Eden; but yielding to the temptation of the serpent, and tasting and leading Adam to taste the forbidden fruit, she was with him driven forth from paradise, and was doomed to sorrows and sufferings, especially in the birth of her offspring. She was the mother of Cain, Abel, and Seth; and with the birth of the last her history ceases.

**EVECTION** (Lat. *evectio*, a carrying out), the principal perturbation of the moon in longitudes, causing her to be alternately nearly three times her own breadth in advance of, and behind, her mean place. The fact of evection was discovered by Ptolemy, but its cause was unknown before the law of gravitation was discovered. It arises from the disturbing influence of the sun, alternately elongating the moon's orbit and reducing its eccentricity, as the end or side of the orbit is toward the sun.

**EVELYN, John**, an English author, born in Wotton, Surrey, Oct. 31, 1620, died there, Feb. 27, 1706. He was educated at Balliol college, Oxford, studied law, and served for a short time in 1641 as a volunteer in the Netherlands. He returned to England as the civil war was breaking out, and joined the royal army, but after the king's retreat to Gloucester travelled through France and Italy. He returned in 1651, assisted in the restoration of 1660; and was received with favor at court. He was one of the founders of the royal society in 1662, a member of the first council, and during his life a constant contributor to its "Transactions." Upon the breaking out of the Dutch war in 1664 he was a commissioner to tend the sick and wounded, and he was one of the first members of the board of trade. The English naval commissioners dreading a scarcity of naval timber in the country, at the request of the royal society Evelyn wrote his "Sylva, or a Discourse on Forest Trees, and the Propagation of Timber in his Majesty's Dominions" (folio, 1664). It induced many landholders to plant an immense number of young oak trees, which furnished the ship yards of the next century. He published many other popular works on learned subjects, on painting, sculpture, architecture, and medals, and was one of the first in England to treat gardening and planting scientifically. The most valuable of his works is a diary, in which during the greater part of his life he related the events in which he was interested. This was edited by W. Brady (4 vols. 4to, 1818), and contains much curious and minute information concerning the manners and society of his time. An enlarged edition was edited by John Forster (4 vols. 8vo, 1859), and editions in 1 vol. 8vo appeared in 1870 and 1871.

**EVERDINGEN, Aldert van**, a Dutch marine and landscape painter, born in Alkmaar in 1621, died there in 1675. He excelled in painting wild and rugged scenery. Having been shipwrecked on the coast of Norway during a voyage to the Baltic, he employed the time while the vessel was repairing in making sketches of rocks, waterfalls, and other prominent features of a mountainous country. His sea pieces, particularly those in which storms are represented, are very effective, being painted with a broad, free pencil, and carefully colored. He also etched upward of 100 prints of Norwegian scenery, besides 56 illustrations to the fable of "Reynard the Fox."

**EVERETT, Alexander Hill**, an American diplomatist and author, born in Boston, March 19, 1792, died in Canton, China, May 29, 1847. He graduated at Harvard college in 1806 with the highest honors of his class, although he was the youngest of its members, and in 1807 began to study law in the office of John Quincy Adams. He was attached to Mr. Adams's legation at St. Petersburg in 1809-'11, and after visiting England and France commenced the practice of the law in Boston in 1812. He contributed articles to some of the periodicals of the day, and wrote for one of the Boston journals a series of political papers sustaining the policy of the administration in the war with Great Britain. In 1814 he was secretary of legation to the Netherlands, and on the retirement of Mr. Eustis from that mission in 1818, he was appointed his successor, with the rank of chargé d'affaires. During his residence in the Netherlands he was a frequent contributor to the "North American Review," mostly upon subjects drawn from French literature, and prepared a work which was published in 1821 in London and Boston, under the title of "Europe, or a General Survey of the Political Situation of the Principal Powers, with Conjectures on their Future Prospects." This work attracted much attention, and was translated into German, French, and Spanish. In 1822 he published at London and Boston a work entitled "New Ideas on Population," in opposition to the views of Malthus. In 1824 he returned to the United States, and in 1825 was appointed minister plenipotentiary to Spain. While at this post, as the representative of the only government that had then acknowledged the independence of the South American republics, he became the medium of communication between them and their mother country, and their virtual representative. Here he wrote a work entitled "America, or a General Survey of the Political Situation of the Principal Powers of the Western Continent, with Conjectures on their Future Prospects" (Philadelphia, 1827; London, 1828), intended as a complement to his former publication on Europe. This was also translated into German, French, and Spanish. He promoted the Spanish studies of Washington Irving, who was an attaché of his legation, and also aided Prescott in procuring materials for the history of Ferdinand and Isabella. In 1829 he returned home, and for about five years conducted the "North American Review" as editor and proprietor. He defended in several elaborate papers the policy of a protective tariff, and some articles, in which he reviewed the course and policy of the federal and democratic parties from a historical point of observation, are among his ablest productions. He was chosen to the senate of Massachusetts in 1830, and continued a member of that or the other branch of the legislature for the ensuing five years. He had thus far been a member of the national republican or whig

party, and had drafted the address reported by the convention which in 1831 nominated Henry Clay for the presidency; but during the second term of Jackson's presidency, and after the proclamation against nullification, he became an adherent of the administration. In 1836, 1838, and 1840 he was an unsuccessful candidate for congress. In 1840 he was sent by the government upon a confidential mission to Cuba, and passed two months at Havana. In June, 1841, he accepted the office of president of Jefferson college, Louisiana, but declining health soon compelled him to return to the north. He still continued his contributions to periodical literature, and a duodecimo volume of selections from his critical and miscellaneous essays was published in Boston in 1845, and a second series in 1847. A small volume of poems, original and translated, was published by him in New York in 1845. In the same year he was appointed commissioner to China, and set out for his post in July; but on arriving at Rio de Janeiro his infirm health compelled him to return home. He sailed a second time in 1846, and arrived in Canton, where he was prostrated by disease.

**EVERETT, Edward**, an American statesman, orator, and author, brother of the preceding, born in Dorchester, Mass., April 11, 1794, died in Boston, Jan. 15, 1865. He entered Harvard college in 1807, and graduated in 1811, at the age of 17, with the highest honors. While an undergraduate he was the principal conductor of a magazine published by the students, called the "Harvard Lyceum." He became a tutor in the college, and at the same time pursued his studies in divinity. In 1812 he delivered a poem before the Phi Beta Kappa society on American poets. In 1813 he was settled as pastor over the Brattle street church in Boston, and immediately won reputation by the eloquence and power of his discourses. In 1814 he published a "Defence of Christianity," in reply to the work of George Bethune English entitled "The Grounds of Christianity Examined, by comparing the New Testament with the Old." In the same year he was chosen Eliot professor of Greek in Harvard college, and to qualify himself for his duties, in the spring of 1815 he entered upon an extended course of European travel and study. After a brief stay in England, he went to the university of Göttingen, where he remained for two years. In the winter of 1817-'18 he was at Paris. In the spring of 1818 he went to England, where he became acquainted with many of the leading men of the day, including Scott, Jeffrey, Campbell, Mackintosh, Romilly, and Davy. Returning to the continent, he passed the winter in Italy, and thence made a journey into Greece, returning through Wallachia and Hungary to Vienna. During his residence in Europe, his range of study embraced the ancient classics, the modern languages, the history and principles of the civil and public law, and a comprehensive examina-



tion of the existing political systems of Europe. Upon his return home, in 1819, he entered upon the duties of his professorship, and delivered to the students a series of lectures upon Greek literature and ancient art, which were afterward repeated before large audiences in Boston. He also became editor of the "North American Review," which he conducted till 1824, contributing to it about 50 articles, to which may be added about 60 more contributed while the "Review" was edited by his brother and others succeeding him. He also prepared a translation of Buttman's Greek grammar, and a Greek reader based upon that of Jacobs. In 1824 he delivered a discourse before the Phi Beta Kappa society on the "Circumstances favorable to the Progress of Literature in America," at which Lafayette sat by his side. This was the first of a series of discourses pronounced by him on public occasions, embracing every variety of topic connected with our national history, character, and prospects, and combining in an eminent degree the peculiar charm of popular oratory with the substantial merits of thought and style. His public life began in 1824, when he was elected to congress, and he served by successive reëlections ten years. During the whole period he was a member of the committee on foreign affairs, and in the 20th congress he was chairman of that committee. He also held a place on all the most important select committees, and in every instance he drew either the majority or minority report. He wrote the minority report of the committee on foreign relations upon the controversy with France in the spring of 1835, and took a leading part in the debate upon the subject. He made two or three reports on the claims of American citizens on foreign powers, for spoliations committed on our commerce during the French continental system, and continued the discussion in the "North American Review." He always served on the library committee, and generally on that for public buildings. In 1827 he addressed a series of letters to Mr. Canning on the colonial trade. Besides occasional elaborate public addresses, he prepared several articles of high merit for the "North American Review;" among others a paper in the number for October, 1830, in which the South Carolina doctrine of nullification is discussed and controverted. In the autumn of 1834 he declined a renomination to congress, and in 1835 he was elected governor of Massachusetts. He was afterward three times re-elected, holding the office four years, and was defeated in 1839 by a majority of one vote. The election of Gen. Harrison in 1840, with the appointment of Daniel Webster as secretary of state, led to the selection of Mr. Everett as minister plenipotentiary to England. The relations of the United States with England at that time were grave. The controversy touching the northeastern boundary, which for half a century had been a subject of difference, seemed to have reached a point beyond which

an amicable adjustment was hopeless. The recent burning of the Caroline and the arrest of McLeod had inflamed the public mind in both countries. The case of the Creole, and questions connected with Oregon and Texas, were also elements of irritation. American vessels had been seized and detained by British cruisers on the coast of Africa. Though the settlement of the northeastern boundary and of the Oregon question was transferred to Washington by the appointment on the part of England of Lord Ashburton as special ambassador, yet many important questions were left to Mr. Everett's judgment, unfettered by special instructions. Among the most important was that involving the construction of the first article of the convention between the two countries on the subject of the fisheries. He secured for American fishermen the long disputed right to take fish in the bay of Fundy, and procured the release from the penal colony of Van Diemen's Land of 60 or 70 American citizens convicted of participation in the Canadian rebellion. In the spring of 1843 he was appointed commissioner to China, with a view to establish commercial relations with that country, but he was compelled to decline. Immediately upon his return to the United States in the autumn of 1845, he was chosen president of Harvard university. He entered upon the duties of this new trust with characteristic energy and enthusiasm, but ill health compelled him to resign the post at the end of three years. He afterward prepared a collected edition of his orations and speeches (2 vols. 8vo, 1850). He also superintended the publication of the new edition of the works of Webster, at his special request, and prepared an elaborate memoir, which was prefixed to the first volume. Upon the death of that statesman, in October, 1852, Everett was appointed secretary of state, and held the office during the last four months of President Fillmore's administration. During his brief term of office he adjusted the perplexing affairs of the Crescent City steamer and the Lobos islands, prosecuted with energy the difficult negotiations pertaining to the fisheries, concluded an international copyright convention with Great Britain and a consular convention with France, reviewed the whole subject of Central American affairs in their relations to the government of the United States and Great Britain, and induced congress to establish a mission of the first class to Central America. A prominent question during his administration of the department of state was the joint proposition of Great Britain and France to enter with the United States into a tripartite convention, guaranteeing to Spain in perpetuity the exclusive possession of Cuba. This proposition was declined by the United States, in a diplomatic note drawn up by Mr. Everett. In 1853 he prepared an address for the annual meeting of the American colonization society in Washington, in exposition and

defence of the objects of that association. Before leaving the department of state he was elected by the legislature of Massachusetts to the senate of the United States. He took his seat in the special executive session in March, 1853, and made an able and elaborate speech on the Central American question. In the summer and autumn of 1853, besides an address before the New York historical society on colonization and emigration, and a reply to the protest of Lord John Russell against the doctrines asserted by our government in the note declining the tripartite convention, he spoke more than once in opposition to the proposed new constitution in Massachusetts. The 33d congress was signalized by the introduction of the bill for the repeal of the Missouri compromise, commonly called the Kansas-Nebraska bill. Mr. Everett delivered a speech against the bill, Feb. 8, 1854, characterized by his usual moderate and conservative views, as well as by good taste and good temper. His health, under the pressure of official toil and excitement, now broke down, and in the following May, under the advice of his physician, he resigned his seat. A few months of rest and quiet restored him; and now there began a new phase in his life, and the opening of a new and peculiar sphere of action. In the year 1853 the project of purchasing Mount Vernon by private subscription was first started by Miss Ann Pamela Cunningham, in an address to the women of the United States, under the signature of "A Southern Matron." The proposal was favorably received, and associations of ladies began to be formed in several of the states for the purpose of collecting funds. Mr. Everett had already prepared for the "Encyclopædia Britannica" a life of Washington, afterward separately printed (12mo, New York, 1860); and having been applied to by the mercantile library association of Boston to deliver a lecture during their course of 1855-'6, he proposed that the association should celebrate the next anniversary of the birthday of Washington, and offered to prepare for that occasion a discourse upon his character, the proceeds to be applied to some commemorative purpose. The offer was accepted; and on Feb. 22, 1856, he pronounced his oration on Washington for the first time, before an immense audience at the music hall in Boston. It was immediately repeated at New York, New Haven, and Baltimore, and the proceeds were applied to various objects. It was delivered for the first time for the benefit of the Mount Vernon fund at Richmond, Va., on March 19, 1856; and subsequently it was repeated in different towns and cities nearly 150 times, always, except in a few instances, for the benefit of the Mount Vernon fund. In 1858 he entered into an engagement with Robert Bonner, editor and proprietor of the "New York Ledger," to furnish

an article weekly for that paper for one year in consideration of \$10,000 to be paid in advance to the Mount Vernon fund. These articles were republished as "The Mount Vernon Papers" (12mo, New York, 1861). The entire amount raised by Mr. Everett, who gave also his time and expenses freely, exceeded \$100,000. On Dec. 22, 1857, he delivered in Boston an address on charity and charitable associations for the benefit of the Boston provident association, which was repeated in different parts of the country 15 times, with an aggregate net receipt, for the benefit of various charitable associations, of about \$13,500. On Jan. 17, 1859, he delivered an address in Boston on the "Early Days of Franklin," at the invitation of the association of the Franklin medallists of that city, which was repeated five times, yielding about \$4,000 for the benefit of various charitable and public associations. On Dec. 7, 1858, he pronounced a eulogy on Thomas Dowse, before the Dowse institute, at Cambridge, Mass., which was afterward repeated before the Massachusetts historical society. In 1860 he was nominated as vice president, with John Bell of Tennessee as president, on a "union" ticket, which received 590,631 votes in a popular vote of 4,662,170. On the outbreak of the civil war in 1861 Mr. Everett made several patriotic speeches in the principal cities of the north. At the consecration of the national cemetery at Gettysburg, Pa., Nov. 19, 1863, he delivered the address, afterward published (8vo, Boston, 1864). In the presidential election of 1864 his name was at the head of the Massachusetts ticket as an elector at large, and his vote in the electoral college for Lincoln and Johnson was the closing act of his political career. His last appearance in public was on Jan. 9, 1865, when he made an address in Faneuil hall, Boston, in aid of sending provisions to the suffering people of Savannah. He died on the following Sunday. By direction of President Lincoln, the several executive departments caused appropriate honors to be paid to his memory at home and abroad, and he was the subject of eulogies in public meetings in the leading cities of the Union, several of which were published, including a "Memorial from the City of Boston" and "Proceedings of the Thursday Evening Club [Boston] on the Occasion of the Death of Everett." Besides his addresses, reports, reviews, and other works above enumerated, Everett wrote "The Dirge of Alaric the Visigoth," "Santa Croce," and other poems, and a life of Gen. Stark in Sparks's "American Biography." A collection of his principal public efforts has been published ("Orations and Speeches on Various Occasions," 4 vols. 8vo, Boston, 1869). A statue of Everett by Ball has been placed in the Boston public library, and one by Story in the public garden.

## CONTENTS OF VOLUME VI.

PAGE		PAGE	
Dempster, John.....	5	Desaguadero, a plain.....	34
Dempster, Thomas.....	5	Desaix de Veygoux, Louis Charles	
Demurrage.....	6	Antoine.....	34
Demurrer.....	6	Désaugiers, Marc Antoine Madeleine.	35
Denain.....	6	Desault, Pierre Joseph.....	35
Denarius.....	6	Des Barres, Joseph Frederick Wal-	
Denbigh.....	6	let.....	36
Denbighshire.....	7	Descartes, René.....	36
Denderah.....	7	Descent.....	38
Dendermonde.....	7	Deserter.....	40
Dendrobium.....	8	Desfontaines, René Louiche.....	41
Dengue.....	8	Desful.....	41
Denham, Dixon.....	8	Desha co.....	41
Denham, Sir John.....	9	Deshoulières, Antoinette.....	41
Denina, Giacomo Maria Carlo.....	9	Desman.....	41
Denize, Saint.....	9	Desmarres, Louis Auguste.....	42
Denizen.....	9	Desmidicæ.....	42
Denizli.....	9	Des Moines co.....	43
Denman, Thomas, Lord.....	10	Des Moines.....	44
Denmark.....	10	Des Moines River.....	44
Denmark, Language and Literature		Desmond, Earls of.....	45
of.....	14	Desmond, Jeanne Fitzgerald, Count-	
Denner, Balthasar.....	19	ess of.....	45
Dennie, Joseph.....	19	Desmoulins, Benoit Camille.....	45
Dennis.....	19	Desna.....	46
Dennis, John.....	19	Dessnoyers, Auguste Gaspard Louis	
Denon, Dominique Vivant, Baron.....	20	Boucher, Baron.....	46
Dent co.....	20	Desor, Edward.....	46
Dentalium.....	20	De Soto co., Miss.....	46
Dentatus, Manius Curius.....	21	De Soto parish, La.....	47
Dentistry.....	21	De Soto, Fernando.....	47
Dentition.....	24	Despard, Edward Marcus.....	48
Denton co.....	25	Des Plaines.....	48
Denver.....	25	Dessaix, Joseph Marie.....	48
Degdand.....	26	Dessalines, Jean Jacques.....	48
D'Éon, Chevalier. See Éon.		Dessau.....	48
De Peyster, Johannes.....	26	Dessolles, Jean Joseph Paul August-	
De Peyster, Abraham.....	26	tin, Marquis.....	49
De Peyster, Arent Schuyler.....	27	Desterro.....	49
De Peyster, John Watts.....	27	Destouches, Philippe Néricault.....	49
Deposition.....	27	Destutt de Tracy, Antoine Louis	
Depping, Georges Bernard.....	27	Claude, Count.....	49
Deptford.....	27	Destutt de Tracy, Alexandre César	
De Quincey, Thomas.....	28	Victor Charles, Marquis.....	50
Dera Ghazee Khan.....	29	Destutt de Tracy, Sarah Newton,	
Derayah.....	29	Marchioness.....	50
Derbend.....	29	Detmold.....	50
Derby, Conn.....	29	Detroit.....	50
Derby, Eng.....	29	Detroit River.....	53
Derby, Edward Geoffrey Smith-Stan-		Deucalion, King.....	53
ley, Earl of.....	30	Deuel co.....	54
Derby, Edward Henry Smith-Stan-		Deuteronomy.....	54
ley, Earl of.....	30	Deutz.....	54
Derbysire.....	31	Deux Ponts. See Zweibrücken.	
Derbysire Spar.....	31	Dev. See Demonology.	
Derfflinger, Georg von.....	31	Deventer.....	54
Derz, Lough.....	31	De Vere, Maximilian Schele.....	54
Derham, William.....	32	Devereux. See Essex, Earl of.	
Dermestes.....	32	Devil.....	54
Dermody, Thomas.....	32	Devil Fish.....	55
Derrick. See Crane.		Deville, Charles Sainte-Claire.....	56
Derry. See Londonderry.		Deville, Henri Etienne Sainte-Claire.	56
Dervish.....	32	Devil's Advocate. See Advocatus	
Derwent, three rivers, Eng.....	33	Diaboli.....	
Derwent, a river, Tasmania.....	33	Devil's Bridge.....	56
Derwentwater, James Radcliffe, Earl		Devil's Wall.....	57
of.....	33	Devise.....	57
Derzhavin, Gavril Romanovitch.....	34	Devizes.....	57
Desaguadero, a river.....	34	Devonian.....	57
Devonport.....	53	Devonshire.....	59
Devonshire.....	59	Devrient, Ludwig.....	59
Devrient, Karl August.....	59	Devrient, Philipp Eduard.....	60
Devrient, Gustav Emil.....	60	Devrient, Gustav Emil.....	60
Dew.....	60	Dew.....	60
Dew, Thomas Roderick.....	62	Dew, Thomas Roderick.....	62
Dewberry. See Bramble.		Dewberry. See Bramble.....	
Deweese, William Potts.....	63	Deweese, William Potts.....	63
D'Ewees, Sir Symonds.....	63	D'Ewees, Sir Symonds.....	63
De Wette, Wilhelm Martin Lebe-		De Wette, Wilhelm Martin Lebe-	
recht.....	63	recht.....	63
Dewey, Chester, D. D.....	63	Dewey, Chester, D. D.....	63
Dewey, Orville, D. D.....	63	Dewey, Orville, D. D.....	63
Dewitt co., Texas.....	64	Dewitt co., Texas.....	64
Dewitt co., Ill.....	64	Dewitt co., Ill.....	64
De Witt, Jan.....	64	De Witt, Jan.....	64
Dewsbury.....	65	Dewsbury.....	65
Dexter, Samuel.....	65	Dexter, Samuel.....	65
Dextrine.....	65	Dextrine.....	65
Dey.....	66	Dey.....	66
Deyra Doon.....	66	Deyra Doon.....	66
Dezful. See Desful.		Dezful. See Desful.....	
Dharwar. See Darwar.		Dharwar. See Darwar.....	
Dhawalagiri. See Himalaya.		Dhawalagiri. See Himalaya.....	
Dhole. See Dog.		Dhole. See Dog.....	
Diabetes.....	66	Diabetes.....	66
Diagoras of Melos.....	67	Diagoras of Melos.....	67
Dial.....	63	Dial.....	63
Dialysis.....	70	Dialysis.....	70
Diamagnetism.....	73	Diamagnetism.....	73
Diamantina.....	73	Diamantina.....	73
Diamond.....	73	Diamond.....	73
Diamond District.....	77	Diamond District.....	77
Diana.....	77	Diana.....	77
Diana of Poitiers.....	77	Diana of Poitiers.....	77
Diaphoretics.....	78	Diaphoretics.....	78
Diaphragm.....	78	Diaphragm.....	78
Diarbekir.....	79	Diarbekir.....	79
Diarrhea.....	79	Diarrhea.....	79
Dias, A. Gonçalves.....	80	Dias, A. Gonçalves.....	80
Dias, Bartholomeu.....	80	Dias, Bartholomeu.....	80
Diatase.....	80	Diatase.....	80
Diathermancy.....	80	Diathermancy.....	80
Diatomacæe.....	83	Diatomacæe.....	83
Diaz, Miguel.....	85	Diaz, Miguel.....	85
Diaz del Castillo, Bernal.....	85	Diaz del Castillo, Bernal.....	85
Diaz de Solis, Juan. See Solis.		Diaz de Solis, Juan. See Solis.....	
Dibdin, Charles.....	85	Dibdin, Charles.....	85
Dibdin, Thomas.....	86	Dibdin, Thomas.....	86
Dibdin, Thomas Froggnall.....	86	Dibdin, Thomas Froggnall.....	86
Dibranchiatae.....	86	Dibranchiatae.....	86
Dice.....	86	Dice.....	86
Dice, in mythology.....	86	Dice, in mythology.....	86
Dicentra.....	86	Dicentra.....	86
Dick, Thomas.....	87	Dick, Thomas.....	87
Dickens, Charles.....	88	Dickens, Charles.....	88
Dickens, John.....	90	Dickens, John.....	90
Dickins, Asbury.....	90	Dickins, Asbury.....	90
Dickinson co., Iowa.....	90	Dickinson co., Iowa.....	90
Dickinson co., Kansas.....	90	Dickinson co., Kansas.....	90
Dickinson, Anne Elizabeth.....	90	Dickinson, Anne Elizabeth.....	90
Dickinson, John.....	91	Dickinson, John.....	91
Dickinson College.....	91	Dickinson College.....	91
Dickson co.....	91	Dickson co.....	91
Dickson, Samuel Henry.....	92	Dickson, Samuel Henry.....	92
Diequemare, Jacques François.....	92	Diequemare, Jacques François.....	92
Dictator.....	92	Dictator.....	92

PAGE		PAGE		PAGE	
Dictionary	92	Dionysius, King of Portugal	124	Dodwell, Edward	177
Diets of Crete	95	Dionysius of Alexandria	125	Dodwell, Henry	177
Diderot, Denis	95	Dionysius the Areopagite	125	Does, Jacobus van der	177
Didius Salvius Julianus, Marcus, Emperor	96	Dionysius Exiguus	125	Does, Simon van der	177
Dido	96	Dionysius of Halicarnassus	125	Does, Jacobus van der	177
Didot, family of	96	Dionysus. See Bacchus.		Dog	177
Didot, François	96	Diophantus of Alexandria	126	Dog Days	182
Didot, François Ambroise	96	Dioptrics. See Optics.		Doge	182
Didot, Pierre François	96	Dioscorides, Pedacutus	126	Dog Fish	188
Didot, Henri	96	Dioscuri. See Castor and Pollux.		Dog Grass. See Couch Grass.	
Didot, Saint-Léger	96	Diphtheria	126	Dog Star	188
Didot, Pierre	96	Diplomatics	127	Dogwood	184
Didot, Firmin	96	Dippel, Johann Konrad	127	Dol	185
Didot, Ambroise Firmin	97	Diptera	128	Dolabella, Publius Cornelius	185
Didot, Ilyacinthe	97	Diptychs	130	Dolci, Carlo	185
Didron, Adolphe Napoléon	97	Direc	131	Dôle	185
Didymium	97	Directory, Executive	131	Dolet, Étienne	186
Didymus	97	Dirschau	131	Dolgoruki, family of	186
Diebtsch, Hans Karl Friedrich Anton	97	Disciples, Church of the	132	Dolgoruki, Grigori	186
Diedenhofen	97	Discophoræ. See Jelly Fish.		Dolgoruki, Maria	186
Diefenbach, Lorenz	98	Discount	133	Dolgoruki, Yakov	186
Diefenbach, Johann Friedrich	98	Disinfectants	133	Dolgoruki, Yuri	186
Dieppe	98	Dislocation	135	Dolgoruki, Mikhail (two)	186
Dieskau, Ludwig August	99	Dismal Swamp, Great	135	Dolgoruki, Ivan (two)	186
Diesterweg, Friedrich Adolf Wilhelm	99	Dispensation	136	Dolgoruki, Vasilii (three)	186
Diest	99	Disraeli, Benjamin	136	Dolgoruki, Vladimir	186
Diet	99	Disraeli, Isaac	137	Dolgoruki, Petr	186
Dieterici, Karl Friedrich Wilhelm	100	Disseisin	138	Dollar	186
Dieterici, Friedrich	100	Dissenters	139	Dollart Bay	187
Dietetics	101	Dissociation	139	Dollier de Casson, François	187
Dietz, Fedor	103	Distillation	140	Döllinger, Ignaz	187
Dietz, Friedrich Christian	103	Distillation, Destructive	145	Döllinger, Johann Joseph Ignaz	188
Differential Calculus. See Calculus.		Distillation, Fractional	145	Dollond, John	189
Diffraction of Light. See Light.		Distress	145	Dollond, Peter	189
Digamina	103	District of Columbia	146	Dolmen. See Cromlech.	
Digby co.	103	Dithyrambus	151	Dolomieu, Déodat Gui Sylvain Tan-crède de Gravat de	189
Digby, Sir Kenelm	103	Ditmarsh	151	Dolomite	190
Digby, Kenelm Henry	104	Ditton, Humphrey	151	Dolphin	190
Digestion	104	Diu	151	Dolphin	190
Digges, Leonard	106	Diuretics	151	Domain	194
Digges, Thomas	106	Diver	152	Domat, Jean	195
Digitalis	106	Divi	153	Dombrowski, Jan Henryk	195
Digitigrades	107	Dividing Engine. See Graduation.		Dome	195
Digne	107	Divination	153	Domenech, Emanuel	197
Dijon	107	Diving	154	Domenichino, Zampieri	197
Dike	108	Diving Bell	155	Domesday Book	198
Dike, in geology	109	Divining Rod	156	Domicile	198
Dilke, Charles Wentworth	109	Divisibility	157	Dominic, Saint	199
Dilke, Sir Charles Wentworth (two)	109	Divorce	157	Dominica	201
Dill	110	Dix, Dorothea Lynde	161	Dominical Letter	202
Dillenius, Johann Jakob	110	Dix, John Adams	161	Dominican Republic. See Santo Domingo.	
Dillingen	110	Dix, Morgan	162	Domingo	202
Dillmann, Christian Friedrich August	110	Dixon co.	162	Dominicans	202
Dillon, Peter	110	Dixon, George	162	Dominis, Marc' Antonio de	205
Dilman	111	Dixon, James	162	Dominos	205
Diluvium	111	Dixon, William Hepworth	162	Domitian, Titus Flavius Augustus, Emperor	206
Dime	114	Dixwell, John	163	Domrémy	206
Dimsdale, Thomas	114	Dmitrov	163	Don, a title	206
Dinagepoor	114	Dnieper	163	Don, three rivers	206
Dinan	114	Dniester	163	Doña Ana co.	206
Dinant	115	Doab	163	Donaldson, John William	207
Dinapore	115	Doane, George Washington	164	Donatello	207
Dindorf, Wilhelm	115	Dobberan	164	Donati, Giovanni Battista	207
Dindorf, Ludwig	115	Dobell, Sydney	164	Donatists	207
Dingelstedt, Franz	115	Döbeln	164	Donauwörth	209
Dingo. See Dog.		Döbereiner, Johann Wolfgang	164	Don Benito	209
Dinkelstühl	115	Döbrentel, Gábor	164	Doncaster	209
Dinornis	115	Dobrizhoffer, Martin	164	Don Cossacks, Land of the	209
Dinosaurians	117	Dobrodja. See Dobrudja.		Donders, Frans Cornelius	209
Dinotherium	117	Dobrovsky, Jozef	165	Donegal	210
Dinwiddie co.	117	Dobrudja	165	Donetz	210
Dinwiddie, Robert	118	Dobson, Thomas	165	Dongola	210
Diocese	118	Dobson, William	165	Doniphan co.	210
Diocletian, Emperor	118	Doce, Rio	165	Donizetti, Gaetano	210
Diodati, Domenico	119	Doceta	165	Don Juan	211
Diodati, Giovanni	119	Dock	166	Donne, John	211
Diodon. See Sea Porcupine.		Doctors' Commons	172	Donnybrook	212
Diodorus	120	Doctrinaires	173	Donoso Cortés, Juan Francisco Maria de la Salud	212
Diogenes	120	Dod, Daniel	173	Donovan, Edward	212
Diogenes of Apollonia	121	Dod, Albert Baldwin, D. D.	173	Do, George Thomas	213
Diogenes Laërtius	121	Dodd, William	173	Dooly co.	213
Diomedes (two)	121	Doddridge co.	174	Doon	213
Dion Cassius Coecelianus	122	Doddridge, Philip	174	Door co.	213
Dion Chrysostomus	122	Dodge co., Ga.	174	Dora d'Istria	213
Dion of Syracuse	122	Dodge co., Wis.	174	Dorak	213
Dionæa	122	Dodge co., Minn.	174	Doran, John	213
Dionysius the Elder	123	Dodge co., Neb.	174	Dorchester co.	214
Dionysius the Younger	124	Dodgington, George Bubb	175	Dorchester, Mass.	214
		Dodo	175	Dorchester, Eng.	214
		Dodona	176	Dordogne	214
		Dodsley, Robert	177		

CONTENTS

iii

	PAGE		PAGE		PAGE
Doré, Paul Gustave.....	214	Dracut.....	238	Du Bois-Reymond, Emil.....	233
Doria, Andrea.....	214	Dragoman.....	238	Dubos, Jean Baptiste.....	233
Dorians.....	215	Dragon.....	238	Dubosary.....	233
Doris (two).....	215	Dragon, a lizard.....	238	Dubovka.....	233
Dorking.....	216	Dragonetti, Domenico.....	239	Dubs, Jakob.....	233
Dormouse.....	216	Dragon Fly.....	239	Dubufe, Claude Marie.....	233
Dorn, Heinrich Ludwig Edmund.....	216	Dragon's Blood.....	240	Dubufe, Edouard.....	234
Dornbirn.....	217	Dracuguan.....	240	Dubuisson, Paul Ulrich.....	234
Dorner, Isaac August.....	217	Drainage.....	240	Dubuque co.....	234
Dorog.....	217	Drake, Daniel.....	242	Dubuque.....	234
Dorogobuzh.....	217	Drake, Sir Francis.....	243	Duc, Joseph Louis.....	235
Dorosma.....	217	Drake, Friedrich.....	243	Du Camp, Maxime.....	235
Dorp.....	217	Drake, Joseph Kodman.....	244	Du Cange, Charles du Fresne, Sieur.....	235
Dorpat.....	217	Drake, Nathan.....	244	Ducarel, Andrew Coltéé.....	235
Dorset, Earls of. See Sackville.....		Drake, Samuel Gardner.....	244	Ducas, Michael.....	236
Dorsetshire.....	217	Drake, Francis S.....	244	Ducat.....	236
Dorsey, John Syng.....	218	Drama.....	244	Ducio di Buoninsegna.....	236
Dorsibranchiatus.....	218	Dramburg.....	247	Du Chaillu, Paul Belloni.....	236
Dort, Synod of. See Reformed Protestant Dutch Church.....		Drammem.....	247	Du Châtelet, Gabrielle Émilie le Tonnelier de Breteuil, Marchioness.....	237
Dortmund.....	218	Dranesville.....	247	Duché, Jacob.....	237
Dorus-Gras, Julie Aimée van Steenkiste.....	219	Draper, John William.....	247	Duchêne, André.....	237
Dory.....	219	Draper, John Christopher.....	248	Duchesne, François.....	237
Dositheans.....	220	Draper, Henry.....	248	Duchesne de Gisors, Jean Baptiste Joseph.....	237
Dost Mohammed. See Afghanistan.....		Draper, Sir William.....	248	Ducis, Jean François.....	238
Dotis.....	220	Drabouts.....	248	Duck.....	238
Douai.....	220	Drave.....	249	Duck Hawk. See Falcon.....	
Douarnenez.....	220	Dravidas. See ETHNOLOGY, vol. vi, p. 758.....		Duclos, Charles Pineau.....	232
Douay, Charles Abel.....	220	Drawing.....	249	Ducornet, Louis César Joseph.....	232
Douay, Félix Charles.....	220	Drayton, William.....	253	Ducrot, Auguste Alexandre.....	232
Doubleday, Edward.....	220	Drayton, William Henry.....	253	Ducility.....	232
Doubleloon.....	221	Dream.....	253	Duddon.....	232
Doubs, a river.....	221	Drebbel, Cornelis van.....	255	Duffand, Madame. See Deffand.....	
Doubs, a department.....	221	Dredging.....	256	Dudevant, Amantine Lucille Aurore Dupin.....	232
Douce, Francis.....	221	Dredging, Deep-Sea.....	256	Dudley.....	233
Dougherty co.....	221	Dreilincourt, Charles.....	261	Dudley, family of.....	234
Doughty, Thomas.....	221	Dreinte, Charles.....	260	Dudley, Edmund.....	234
Douglas co., Ga.....	221	Dresden.....	260	Dudley, John.....	234
Douglas co., Ill.....	221	Dreux.....	263	Dudley, Robert.....	234
Douglas co., Wis.....	221	Drew co.....	263	Dudley, Sir Robert.....	234
Douglas co., Minn.....	221	Drew, Samuel.....	263	Dudley, Thomas.....	235
Douglas co., Mo.....	222	Dreyschock, Alexander.....	263	Dudley, Joseph.....	235
Douglas co., Neb.....	222	Dreyse, Johann Nikolaus von.....	264	Dudley, Paul.....	235
Douglas co., Kan.....	222	Drift. See Diluvium.....		Dudley, Benjamin Winslow.....	235
Douglas co., Oregon.....	222	Drill, in mechanics. See Boring.....		Dudley, Charles Edward.....	235
Douglas co., Nev.....	222	Drill, in zoology. See Baboon.....		Dudweiler.....	235
Douglas co., Col.....	222	Drogheda.....	264	Duel.....	235
Douglas co., Dak.....	222	Drohobycz.....	264	Duer, John.....	238
Douglas, Isle of Man.....	222	Droitwich.....	264	Dufaure, Jules Armand Stanislas.....	238
Douglas, Scotland.....	222	Drôme.....	264	Du Fay, Charles François de Cisterney.....	238
Douglas, family of.....	223	Dromedary. See Camel.....		Duff, Alexander.....	238
Douglas, David.....	224	Drontheim.....	265	Dufferin, Frederick Temple Hamilton Blackwood, Earl of.....	239
Douglas, Gawin.....	225	Dronprosy.....	265	Duffy, Sir Charles Gavan.....	239
Douglas, Sir Howard.....	225	Drouet, Annette Elisabeth.....	266	Dufour, Guillaume Henri.....	239
Douglas, John.....	225	Drouet, Jean Baptiste.....	267	Dufour, Léon.....	239
Douglas, Stephen Arnold.....	225	Drouet d'Erlon, Jean Baptiste, Count.....	267	Dufrénoy, Pierre Armand.....	239
Douglass, David Bates.....	223	Drouyn de Lhuys, Edouard.....	267	Du Fresne, Charles. See Du Cange.....	
Douglass, Frederick.....	223	Drowning.....	267	Dufresnoy, Charles Alphonse.....	300
Dour.....	223	Droysen, Johann Gustav.....	263	Dufresny, Charles Rivière.....	300
Douro.....	223	Droz, François Xavier Joseph.....	268	Dugdale, Sir William.....	300
Douroucouli.....	223	Droz, Gustave.....	269	Dugong.....	300
Douville, Jean Baptiste.....	229	Droz, Pierre Jacquet.....	269	Duguay-Trouin, René.....	302
Douw, Gerard.....	229	Droz, Henri Louis Jacquet.....	269	Du Guesclin, Bertrand.....	302
Dove. See Pigeon.....		Druids.....	269	Du Halde, Jean Baptiste.....	302
Dove, a river.....	229	Drum.....	271	Duhamel, Jean Marie Constant.....	302
Dove, Heinrich Wilhelm.....	230	Drummond, Thomas.....	271	Duida.....	303
Dove, Richard Wilhelm.....	230	Drummond, William.....	272	Dnilius, Caius Nepos.....	303
Dover, Eng.....	230	Drummond, Sir William.....	272	Duisburg.....	303
Dover, N. H.....	231	Druses.....	272	Dujardin, Félix.....	303
Dover, N. J.....	232	Drusus, Claudius Nero.....	275	Dujardin, Karel.....	303
Dover, Del.....	232	Drusus, Cæsar.....	276	Duke.....	303
Dover, Ohio.....	232	Druses. See Druses.....		Dukes County.....	304
Dover, Strait of.....	232	Dryads.....	276	Dukinfield.....	304
Dover's Powder.....	232	Dryander, Jonas.....	276	Dulaure, Jacques Antoine.....	304
Dovrefield.....	232	Dryden, John.....	276	Dulcamara.....	304
Dow, Lorenzo.....	232	Drying Oils.....	278	Dulce, a lake.....	304
Dower.....	233	Dry Rot.....	278	Dulce, a gulf.....	304
Dowler, Bennet.....	234	Dry Tortugas.....	278	Dulce, a river.....	304
Dowletabad.....	235	Dualline. See Explosives.....		Dulcigno.....	305
Down co.....	235	Duane, William.....	278	Dulcimer.....	305
Downes, John.....	235	Duban, Jacques Félix.....	279	Dulong, Pierre Louis.....	305
Downing, Andrew Jackson.....	235	Du Barry. See Barry.....		Dulse. See Algae.....	
Downpatrick.....	236	Dublin co.....	279	Duluth.....	305
Dowse, Thomas.....	236	Dublin.....	279	Dulwich.....	306
Doxology.....	236	Dübner, Friedrich.....	282	Dumanoir, Philippe François Pinel.....	306
Doyle, Richard.....	237	Dubno.....	282	Dumas, Alexandre Davy, Gen.....	306
Dozy, Reinhart.....	237	Dubois co.....	282		
Drachenfels.....	237	Dubois, Antoine, Baron.....	282		
Drachma.....	237	Dubois, Paul Antoine.....	282		
Draco.....	237	Dubois, Guillaume.....	282		
		Dubois, Jean Antoine.....	283		

PAGE		PAGE	PAGE
806	Dumas, Alexandre Davy.....	827	East .....
808	Dumas, Alexandre.....	828	East Baton Rouge parish.....
808	Dumas, Jean Baptiste.....	829	East Birmingham, Pa. See Bir-
808	Dumas, Mathieu, Count.....	829	mingham.....
809	Dumas, Chrétien Léon, Count.....	829	Eastburn, James Wallis.....
809	Dumbarton.....	829	878
809	Dumbarthonsire.....	829	Eastburn, Manton.....
809	Dumblun.....	830	878
809	Dumcrl, André Marie Constant.....	830	East Bridgewater. See Bridge-
809	Dumcrl, Auguste Henri André.....	831	water.....
809	Dumfrices.....	831	Easter .....
810	Dumfriesshire.....	831	878
810	Dümichen, Johannes.....	831	Easter Island.....
810	Dummer, Jeremiah.....	831	874
810	Dumont, Pierre Étienne Louis.....	831	Eastern Empire. See Byzantine
811	Dumont d'Urville, Jules Sébastien	832	Empire.....
811	César.....	832	East Feliciana parish.....
811	Dumouriez, Charles François.....	832	875
811	Düna.....	832	East India Companies.....
812	Dünaburg.....	832	875
812	Dunbar.....	832	East Indies.....
812	Dunbar, William.....	832	878
812	Duncan. See Macbeth.....	832	Eastlake, Sir Charles Lock.....
812	Duncan, Adam, Admiral.....	832	879
812	Duncan, Thomas.....	832	Eastland co.....
813	Duncker, Karl.....	832	879
813	Duncker, Maximilian Wolfgang.....	832	East Liverpool.....
813	Duncker, Franz Gustav.....	832	879
813	Duncker, Hermann.....	832	Eastport.....
813	Dundalk.....	832	880
813	Dundas co.....	832	East River.....
813	Dundas, Henry.....	832	880
814	Dundee.....	832	East River Bridge. See Bridge,
814	Dundonald, Thomas Cochrane, Earl	832	and Brooklyn.....
815	of.....	832	East Saginaw.....
815	Dundrum Bay.....	832	880
815	Dunedin.....	832	Eaton co.....
815	Dunfermline.....	832	881
815	Dunganon.....	832	Eaton, Amos.....
815	Dungarvan.....	832	881
815	Dunglison, Robley.....	832	Eaton, George W.....
816	Dunkeld.....	832	881
816	Dunkers.....	832	Eaton, William.....
817	Dunkirk, France.....	832	882
817	Dunkirk, N. Y.....	832	Eau Claire co.....
817	Dunklin co.....	832	882
817	Dunlap, William.....	832	Eau de Cologne.....
818	Dun-le-Roi.....	832	882
818	Dunn co.....	832	Eau de Luce.....
818	Dunning, John.....	832	882
818	Dunnottar.....	832	Ebal and Gerizim.....
818	Dunois, Jean, Comte de.....	832	883
818	Duns Scotus, John.....	832	Ebeling, Christoph Daniel.....
819	Dunstable.....	832	883
819	Dunstan, Saint.....	832	Ebenezer.....
819	Dunster, Henry.....	832	883
819	Dunton, John.....	832	Eberhard im Bart.....
819	Duodecimal.....	832	883
819	Du Page co.....	832	Eberhard, Johann August.....
820	Dupanloup, Félix Antoine Philippe	832	883
820	Dupaty, Charles Marguerite Jean	832	Ebers, Georg Moritz.....
820	Baptiste Mercier.....	832	883
820	Duperrey, Louis Isidor.....	832	Ebionites.....
820	Duperron, Jacques Davy, Cardinal.....	832	883
821	Du Petit-Thouars, Abel Aubert.....	832	Ebn. See Ben.....
821	Dupin, André Marie Jean Jacques.....	832	884
821	Dupin, Pierre Charles François, Ba-	832	Eboli, Anna de Mendoza, Princess
821	ron.....	832	of.....
822	Dupleix, Joseph François, Marquis.....	832	884
822	Duplessis-Mornay. See Mornay.....	832	Ebon.....
822	Duplin co.....	832	884
822	Duponceau, Peter Stephen.....	832	Ebrata.....
822	Dupont, Jacques Charles.....	832	885
823	Du Pont, Samuel Francis.....	832	Echellensis, Abraham.....
823	Dupont de l'Étang, Pierre, Count.....	832	885
823	Du Pont de Nemours, Pierre Samuel.....	832	Ecclesia.....
824	Duport, James.....	832	886
824	Duprat, Antoine.....	832	Ecclesiastes.....
825	Duprez, Gilbert Louis.....	832	886
825	Duprez, Caroline van den Heuvel.....	832	Ecclesiasticus.....
825	Duprez, Édouard.....	832	886
825	Dupuis, Charles François.....	832	Echeneis. See Sucking Fish.....
825	Dupuytren, Guillaume.....	832	886
825	Duquesne, Abraham.....	832	Echeverria, Estéban.....
825	Duquesne, Fort. See Pittsburgh.....	832	886
826	Duram, José de Santa Rita.....	832	Echidna. See Porcupine Ant-Eater.....
826	Durand, Asher Brown.....	832	886
826	Durango.....	832	Echinades.....
827	Durante, Francesco.....	832	886
827	Durazzo.....	832	Echinoderms.....
827	Durbin, John Price, D. D.....	832	887
827	Düren.....	832	Echinus.....
827		832	888
		832	Echo, in mythology.....
		832	890
		832	Echols co.....
		832	890
		832	Écija.....
		832	890
		832	Eck, Johann Mayr von.....
		832	890
		832	Eckermann, Johann Peter.....
		832	890
		832	Eckersberg, Christoph Wilhelm.....
		832	890
		832	Eckford, Henry.....
		832	891
		832	Eckhart, Meister.....
		832	891
		832	Eckmühl.....
		832	891
		832	Eckstein, Ferdinand, Baron d'.....
		832	891
		832	Eclectics.....
		832	891
		832	Eclipse.....
		832	891
		832	Ecliptic. See Sucking Fish.....
		832	892
		832	Ecuador.....
		832	892
		832	Edda.....
		832	899
		832	Eddestone Rocks.....
		832	400
		832	Eden.....
		832	400
		832	Edentata.....
		832	400
		832	Edessa, in Asia.....
		832	401
		832	Edessa, in Europe.....
		832	402
		832	Edfoo.....
		832	402
		832	Edgar co.....
		832	403
		832	Edgar, King.....
		832	403
		832	Edgar Atheling.....
		832	403
		832	Edgartown.....
		832	403
		832	Edgecombe co.....
		832	404
		832	Edgefield co.....
		832	404
		832	Edgehill.....
		832	404
		832	Edgeworth, Richard Lovell.....
		832	404
		832	Edgeworth, Maria.....
		832	404
		832	Edgeworth of Firmont, Henry Al-
		832	len, Abbé.....
		832	404

## E

CONTENTS

V

	PAGE		PAGE		PAGE
Edinburgh	405	Ekatërinograd. See Yekaterinograd.		Elizabeth of Valois, Queen	538
Edinburghshire	408	Ekatërinoslav. See Yekaterinoslav.		Elk	538
Edisto	408	Ekhmin	484	Elk co.	541
Edmonds, John Worth	408	Ekron	484	Elkhart co.	541
Edmondson co.	408	Elagabalus, Varius Avitus Bassianus, Emperor	484	Elkhart	541
Edmund I.	408	Elam	485	Elko co.	541
Edmund II.	408	Eland	486	Ellenborough, Edward Law, Baron	541
Edmunds co.	409	El-Araish	487	Ellenborough, Edward Law, Earl of	542
Edom	409	El-Araish	487	Ellenborough, Jane Elizabeth	542
Edred, King	410	Elasmosaurians	487	Elery, William	542
Edrisi	410	Elastic Curve	488	Ellesmere, Francis Egerton, Earl of	542
Education	410	Elasticity	488	Ellet, Charles, jr.	543
Edward the Elder	432	Elaterium	492	Ellet, William Henry	543
Edward the Martyr	432	Elath	492	Ellet, Elizabeth Fries Lummis	543
Edward the Confessor	432	Elba	492	Ellicott, Andrew	543
Edward I., King of England	433	Elbe	493	Ellicott, Joseph	544
Edward II., King of England	436	Elberfeld	493	Ellicott, Charles John	544
Edward III., King of England	435	Elbert co.	494	Ellicott City	544
Edward IV., King of England	436	Elbeuf	494	Elliot, George Thomson	544
Edward V., King of England	437	Elbing	494	Elliots, John	544
Edward VI., King of England	438	Elburz	494	Elliott co.	545
Edward the Black Prince	439	Eleesaites	494	Elliott, Charles D. D.	545
Edwardes, Sir Herbert Benjamin	439	Elche	494	Elliott, Charles Loring	545
Edwardes co., Texas	440	Elchingen, Ober and Unter	495	Elliott, Charles Wyllys	545
Edwards co., Ill.	440	Elder, an overseer	495	Elliott, Ebenezer	545
Edwards, Amelia Blandford	440	Elder, a shrub	495	Elliott, Jesse Duncan	546
Edwards, Bela Bates	440	Eldon, John Scott, Earl of	496	Elliott, Stephen	546
Edwards, Bryan	440	El Dorado	496	Elliott, Stephen	547
Edwards, George	440	El Dorado co.	496	Elliott, William	547
Edwards, John	440	Eleanor of Aquitaine, Queen	496	Ellipse	547
Edwards, Jonathan	441	Eleatic School	497	Ellis co., Texas	547
Edwards, Jonathan	444	Eleazar (two)	497	Ellis co., Kansas	547
Edwards, Justin	445	Elecampene	497	Ellis, George	547
Edwards, Milne. See Milne-Edwards.		Electer	498	Ellis, George Edward, D. D.	547
Edwards, Richard	445	Electra	498	Ellis, George James Welbore Agar	548
Edwards, Tryon	445	Electric Fishes	498	Ellis, Sir Henry	548
Edwin, King	445	Electricity	500	Ellis, William (two)	548
Edwy, King	445	Electric Light	510	Ellis, Sarah Stickney	548
Eeckhout, Gerbrant van den	446	Electro-Magnetism	511	Elliston, Robert William	548
Eecloo	446	Electro-Metallurgy, Electrotyping. See Galvanism.		Ellora	549
Eel	446	Element, Chemical	517	Ellsworth co.	549
Eel, Electrical. See Electric Fishes.		Elemi	517	Ellsworth, Oliver	549
Eel-Pout. See Burbot.		Eleonora of Este, Princess	517	Ellsworth, William Wolcott	550
Eels. See Ilyats.		Elephant	518	Ellwangen	550
Eesah. See Somaul.		Elephanta	522	Ellwood, Thomas	550
Effervescence	448	Elephantiasis	522	Elm	550
Effervescing Powders	448	Elephantine	523	Elmacinus, George	552
Effingham co., Ga.	448	Eleusis	523	Elmes, James	552
Effingham co., Ill.	448	Eleutheria	524	Elmina	552
Eft	448	Elgin co.	524	Elmira	552
Égalité, Philippe. See Orleans.		Elgin, Ill.	524	Elmore co.	552
Egbert, King	449	Elgin, Scotland	524	Elmsley, Peter	553
Egede, Hans	449	Elgin, Thomas Bruce, Earl of	524	Eloction. See Oratory, and Voice.	
Egede, Paul	449	Elgin, James Bruce, Earl of	525	Elohm	553
Eger	449	Elgin Marbles	525	El Paso co., Texas	553
Egerla	450	Elginshire	526	El Paso co., Col.	553
Egerton, Francis. See Bridgewater.		Elj	526	El Paso	553
Egerton, Thomas	450	Elias. See Elijah.		Elphinstone, James	553
Egg	450	Elias Levita	526	Elphinstone, George. See Keith.	
Egg, Augustus Leopold	451	Élie de Beaumont, Jean Baptiste Armand Louis Léonce	526	Elphinstone, Mounstuart	553
Egg Plant	451	Elijah	527	Elphinstone	553
Eginhard	452	Ellet, Charles William	527	Elsinore	553
Egmont, Lamoral, Count of	452	Eliot, George. See Lewes, Marian Evans.		Elsler, Fanny and Therese	554
Egret	453	Eliot, John	527	Elton	554
Egypt	454	Eliot, Jared	528	Elvas	554
Egypt, Language and Literature of	469	Eliot, John	528	Elwes, John	555
Ehnhorn, John Whetton	479	Eliot, Samuel	528	Ely	555
Ehrenberg, Christian Gottfried	479	Eliott, George Augustus	529	Elymais	555
Ehrenbreitstein	480	Elis	529	Elysiun	556
Elbenstock	480	Elisabethgrad	529	Elzevir, family of	556
Elchendorff, Joseph Karl Benedict, Baron	480	Elisabethpol	529	Elzevir, Louis (three)	556
Elchhorn, Johann Gottfried	480	Elisha	529	Elzevir, Matthaus	556
Elchstadt	481	Elixir	530	Elzevir, Gilles	556
Elchwald, Edward	481	Elizabeth	530	Elzevir, Joost	556
Eider	481	Elizabeth, Queen of England	530	Elzevir, Bonaventura	556
Eider Duck	481	Elizabeth, Queen of Spain	535	Elzevir, Abraham	556
Eildon Hills	482	Elizabeth of France	535	Emanuel co.	557
Eilenburg	483	Elizabeth, Saint	535	Emanuel I.	557
Eimbeck	483	Elizabeth Charlotte	536	Embalming	557
Einsiedeln	483	Elizabeth Christina, Queen	536	Embargo	559
Eisenach	483	Elizabeth City co.	536	Ember Days	559
Eisenberg	483	Elizabeth City	537	Embezzlement	559
Eisenburg co. See Vas.		Elizabeth Farnese, Queen	537	Emblems	559
Eisenlohr, Wilhelm Friedrich	484	Elizabeth Islands	537	Embracery	560
Eisenstadt	484	Elizabeth Petrovna, Empress	537	Embrun	560
Eisleben	484	Elizabeth Stuart, Queen	538	Embryology	560
Eisteddfods	484			Embury, Emma Catharine	567
Ejectment	484			Embury, Philip	567
Ekatërinburg. See Yekaterinburg.				Emden	567
				Emerald	567
				Emerald Hill	568

	PAGE		PAGE		PAGE
Emerson, George Barrell	568	Epanomeria	676	Ersch, Johann Samuel	719
Emerson, Ralph Waldo	568	Épée, Charles Michel, Abbé de l'	676	Erse. See Celts, Languages and Literature of the.	
Emery	570	Eperies	676	Erskine, Ebenezer	719
Emetics	571	Epernay	677	Erskine, Thomas, Baron	719
Emigration	571	Ephah	677	Erymanthus	720
Eminent Domain	582	Ephemeræ	677	Erysipelas	720
Emir	583	Ephesians, Epistle to the	677	Erythæma	721
Emlyn, Thomas	583	Ephod	679	Erythræan Sea	721
Emmanuel	583	Ephors	679	Eryx	722
Emmenagogues	583	Ephraem Syrus	679	Erzerum	722
Emmerich	583	Ephraim	680	Erzgebirge	723
Emmet co.	583	Épicharmus	680	Esarhaddon	723
Emmet, Robert	583	Épictetus	680	Escambia co.	723
Emmet, Thomas Addis	584	Épicyurus	680	Escheat	723
Emmet, John Patton	584	Epidamnus. See Dyrrhachium.		Eschenbach, Wolfram von	724
Emmett co.	584	Epidaurus	682	Eschenmayer, Karl Adolf August von.	724
Emmetsburg	584	Epidemic Diseases	682	Eschwege	724
Emmons, Nathaniel	584	Epidermis	682	Eschweiler	724
Emory, John	585	Épigoni	682	Escobar y Mendoza, Antonio	724
Emory, Robert	585	Epilepsy	682	Escurial	725
Empedocles	585	Épiménides	685	Esdras, Books of	726
Emperor	585	Épinal	685	Esk, several rivers	726
Empysemæ	586	Épinay, Louise Florence Pétronille de la Live d'	685	Eski-Sagra	727
Empoli	588	Épiornis	685	Esmeralda co.	727
Ems, a river	588	Épiphanus, Saint	685	Esmeraldas, a river	727
Ems, a town	588	Épiphy	685	Esmeraldas, a province	727
Emser, Hieronymus	588	Épiphytes	686	Esne	727
Emu	588	Épirus	690	Espartero, Joaquin Baldomero	728
Enaliosaurians	589	Épiscopal Church, Protestant	690	Esparto	728
Enamelling	589	Épiscopius, Simon	692	Espinasse, Mlle. de l'. See Lespinasse.	
Encaustic	591	Épistole Obscurorum Virorum	693	Espinel, Vicente	728
Encke, Johann Franz	592	Épithelium	693	Espirito Santo	729
Enclinite	592	Épizoa	693	Espy, James P.	729
Encyclopædia. See Cyclopædia.		Epsom	698	Esquimaux	729
Ender, Johann Nepomuk	593	Epsom Salt	698	Esquire	731
Endicott, John	593	Équator	699	Esquirol, Jean Étienne Dominique	731
Endlicher, Stephan Ladislaus	593	Équinox. See Equator.		Esquiros, Henri Alphonse	731
Endogens	594	Équites	699	Ess, Heinrich Leander van	732
Endor	594	Équity	699	Esseg. See Eszék.	
Endosmose	594	Equity of Redemption. See Mortgage.		Essen	732
Endymion	595	Equivalent, Chemical	700	Essen, Hans Henrik, Count	732
Enfantin, Barthélemy Prosper	595	Érad, Sébastien	702	Essences. See Essential Oils.	
Enfield, Conn	596	Érad, Jean Baptiste Orphée Pierre	702	Essenes	732
Enfield, Eng	596	Erasmus, Desiderius	702	Essential Oils	733
Enfield, William	596	Erastus, Thomas	704	Essequibo, a river	734
Engadine	596	Erath co.	704	Essequibo, a territory	734
Enghien, Louis Antoine Henri de Bourbon, Duke d'	597	Erato	704	Essex co., Vt	734
England	597	Eratosthenes	704	Essex co., Mass	734
England, Church of	626	Erbium	704	Essex co., N. Y.	734
England, Language and Literature of	629	Ercilla y Zuñiga, Alonso de	705	Essex co., N. J.	735
England, John	647	Ereckmann-Chatrian (Émile Ereckmann and Alexandre Chatrian)	705	Essex co., Va	735
English, George Bethune	647	Erdmann, Johann Eduard	706	Essex co., Canada	735
English, Thomas Dunn	647	Erdmann, Otto Linné	706	Essex co., England	735
English Channel	648	Erabus	706	Essex, Karls of. See Cromwell, Thomas.	
Engrafting. See Grafting.		Erechtheus	706	Essex, Walter Devereux, Earl of	735
Engraving	648	Eregli	706	Essex, Robert Devereux, Earl of	736
Enkhuisen	656	Eremaeus	707	Essling. See Aspern and Essling.	
Enmosen, Joseph	656	Eretria	707	Esslingen	736
Ennis	656	Erfurt	707	Estaing, Charles Hector, Count d'	736
Enniscorthy	656	Ergot	708	Estate	737
Enniskillen	656	Eric IX	709	Este	739
Ennius, Quintus	656	Eric XIV	709	Este, family of	739
Enns, a river	657	Eriasson, John	709	Estella	740
Enns, a town	657	Eriasson, Nils	710	Estepa	740
Enoch	657	Eridanus	710	Estepona	740
Enriquez Gomez, Antonio	657	Erie co., N. Y.	710	Esterházy, family of	740
Ensinall co.	658	Erie co., Pa.	711	Esther	740
Entail	658	Erie co., Ohio	711	Esthonia	741
Enteritis	658	Erie	711	Estienne. See Stephens.	
Enterology	658	Erie, Lake	712	Estill co.	742
Entomology	658	Erie, Lake, Battle of	713	Estoppel	742
Entomotræca	658	Eries	714	Estovers	742
Entophytes. See Epiphytes.		Erigena, John Scotus	714	Estrays	742
Entozoa	663	Erivan	714	Estreat	742
Entragues, Catherine Henriette de Balzac d'	671	Erlangen	715	Estrees, Gabrielle d'	742
Entrecaesteux, Joseph Antoine Bruni d'	671	Erlau	715	Estrella, Serra da. See Portugal.	
Entre Douro e Minho. See Minho.		Erman, Paul	715	Estremadura, Portugal	742
Entre-Rios	671	Erman, Georg Adolf	715	Estremadura, Spain	743
Envermeu	672	Ermeland	716	Estremoz	743
Enzio	672	Ermine	716	Eszék	743
Eocene	672	Erne, Lough	717	Étampes	743
Eon de Beaumont, Charles Geneviève Louis Auguste André Timothée d'	673	Ernest Augustus, King	717	Étampes, Anne de Pisseleu, Duchesse d'	743
Eos. See Aurora.		Ernest, Johann August	718	Etawah	743
Eötvös, József, Baron	674	Ernest, August Wilhelm	718	Étchemins	743
Bozon	674	Ernst, Heinrich Wilhelm	718	Éteocles and Polynices	744
Epact	674	Eros	718	Étesian Winds	744
Epaminondas	675	Erstratus	718		
		Erpenius, Thomas	719		



	PAGE		PAGE		PAGE
Étex, Antoine.....	744	Euclid.....	769	Eurydice (two).....	789
Ethelbald, King.....	744	Euclid of Megara.....	770	Eusebius.....	789
Ethelbert, King of Kent.....	744	Eudiometer.....	770	Eustachi, Bartolommeo.....	790
Ethelbert, King of the Anglo-Sax- ons.....	744	Eudocia, a Roman Empress.....	770	Eustis, William.....	790
Ethelred I.....	745	Eudocia, a Byzantine Empress.....	771	Eutaw Springs.....	790
Ethelred II.....	745	Eudoxia, Empress.....	771	Euterpe.....	791
Ethelwulf, King.....	745	Eudoxus of Cnidus.....	771	Eutyches.....	791
Ether.....	746	Eufaula.....	771	Euxine Sea. See Black Sea.	
Ether, in chemistry.....	747	Eugene, Prince.....	771	Evagoras, King.....	791
Etherege, Sir George.....	748	Eugénie, Empress. See Bonaparte, vol. iii, p. 55.		Evagrius.....	791
Etheridge, John Wesley.....	748	Eugenius, popes.....	773	Ewald, Johannes.....	791
Ethics. See Moral Philosophy.		Euler, Leonhard.....	774	Evangelical Alliance.....	792
Ethiopia.....	749	Eunenes.....	775	Evangelical Association.....	792
Ethiopia, Languages and Literature of.....	750	Eumenides.....	775	Evangelist.....	793
Ethnology.....	753	Eunapius.....	775	Evans, Sir De Lacy.....	793
Ethyle.....	760	Eunomius.....	776	Evans, Edward P.....	793
Etna.....	761	Eunuchs.....	776	Evans, Frederick William.....	794
Eton.....	763	Eupatoria.....	776	Evans, Lewis.....	794
Etowah co.....	764	Eupatorium. See Boneset.		Evans, Marian. See Lewes, Marian Evans.	
Etruria.....	764	Eupen.....	777	Evans, Oliver.....	794
Ettlingen.....	766	Euphorbia.....	777	Evanson.....	794
Etty, William.....	766	Euphrates.....	777	Evansville.....	794
Etymology. See Language.		Euphuism.....	778	Evaporation.....	795
Eu.....	767	Euphuism.....	778	Evarts, Jeremiah.....	797
Eu, Louis Philippe Marie Ferdinand Gaston d'Orleans, Count d'.....	767	Eupolis.....	778	Evarts, William Maxwell.....	797
Eubœa.....	767	Eure.....	779	Eve.....	797
Eubulides of Miletus.....	767	Eure-et-Loir.....	779	Evection.....	797
Eucalyptus.....	768	Euripides.....	779	Evelyn, John.....	797
Eucharist. See Lord's Supper.		Euripus.....	780	Everdingen, Aldert van.....	797
Euchre.....	769	Europa.....	780	Everett, Alexander Hill.....	798
		Europe.....	781	Everett, Edward.....	798
		Eurotas.....	789		







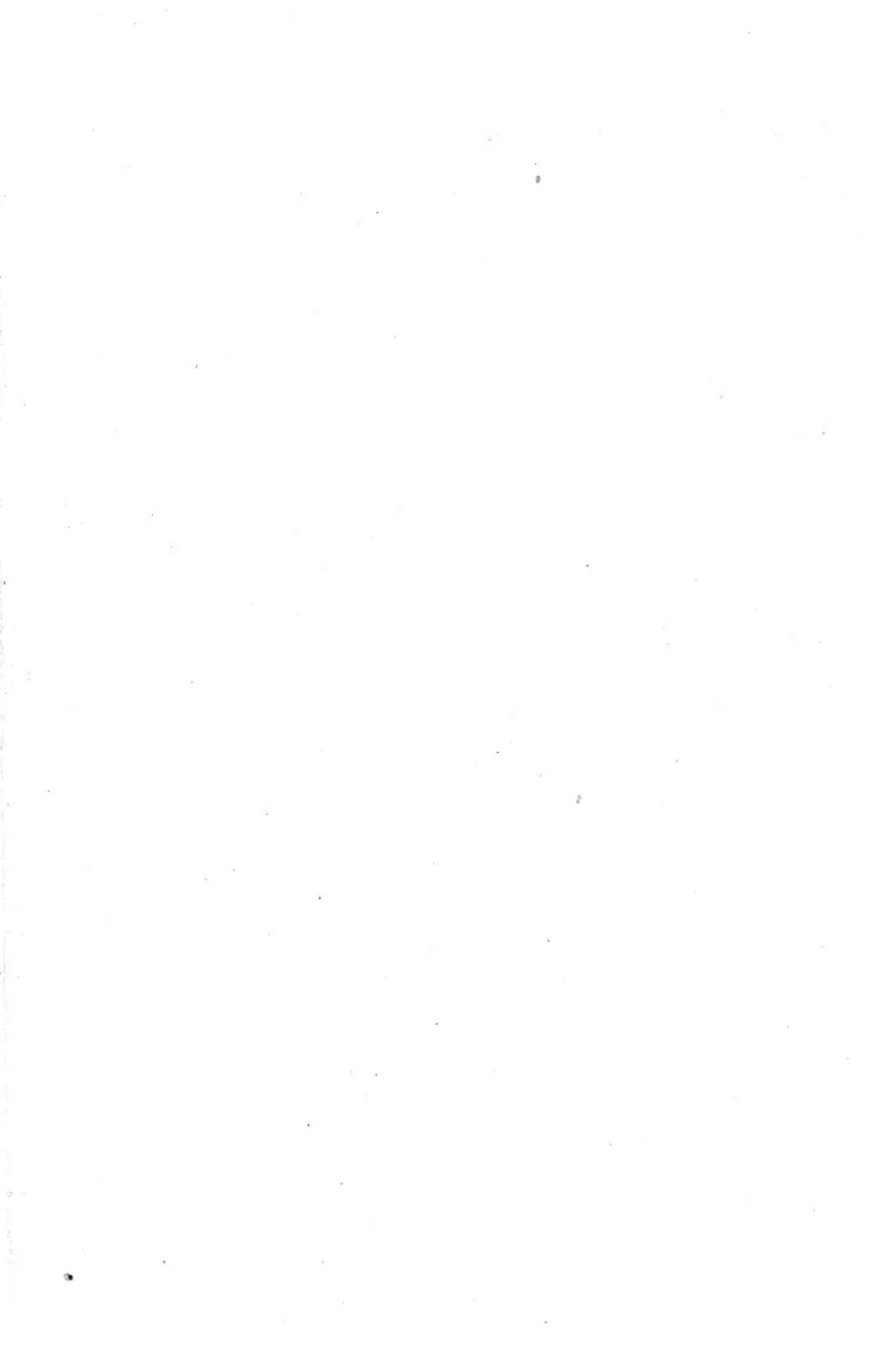

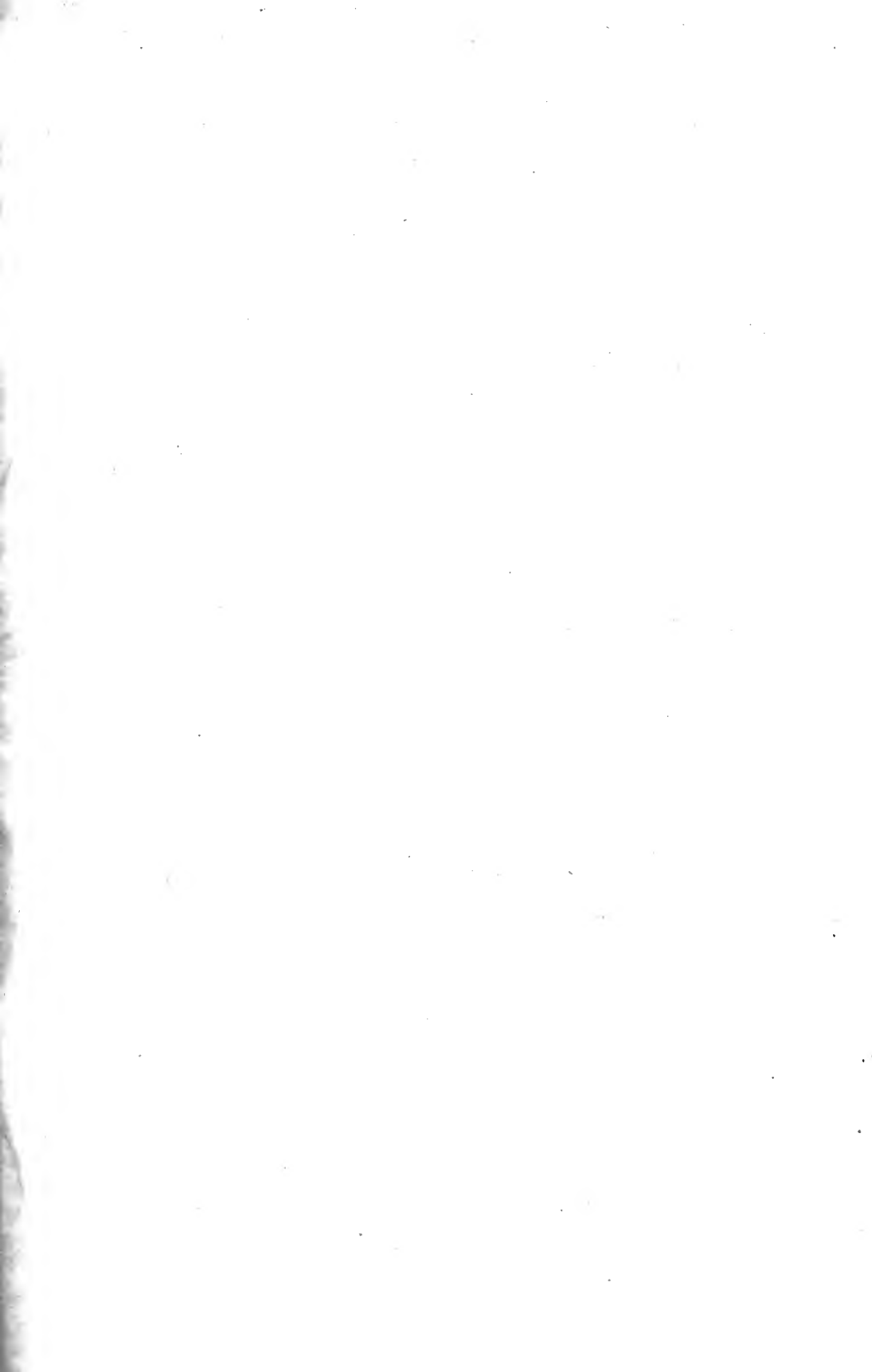

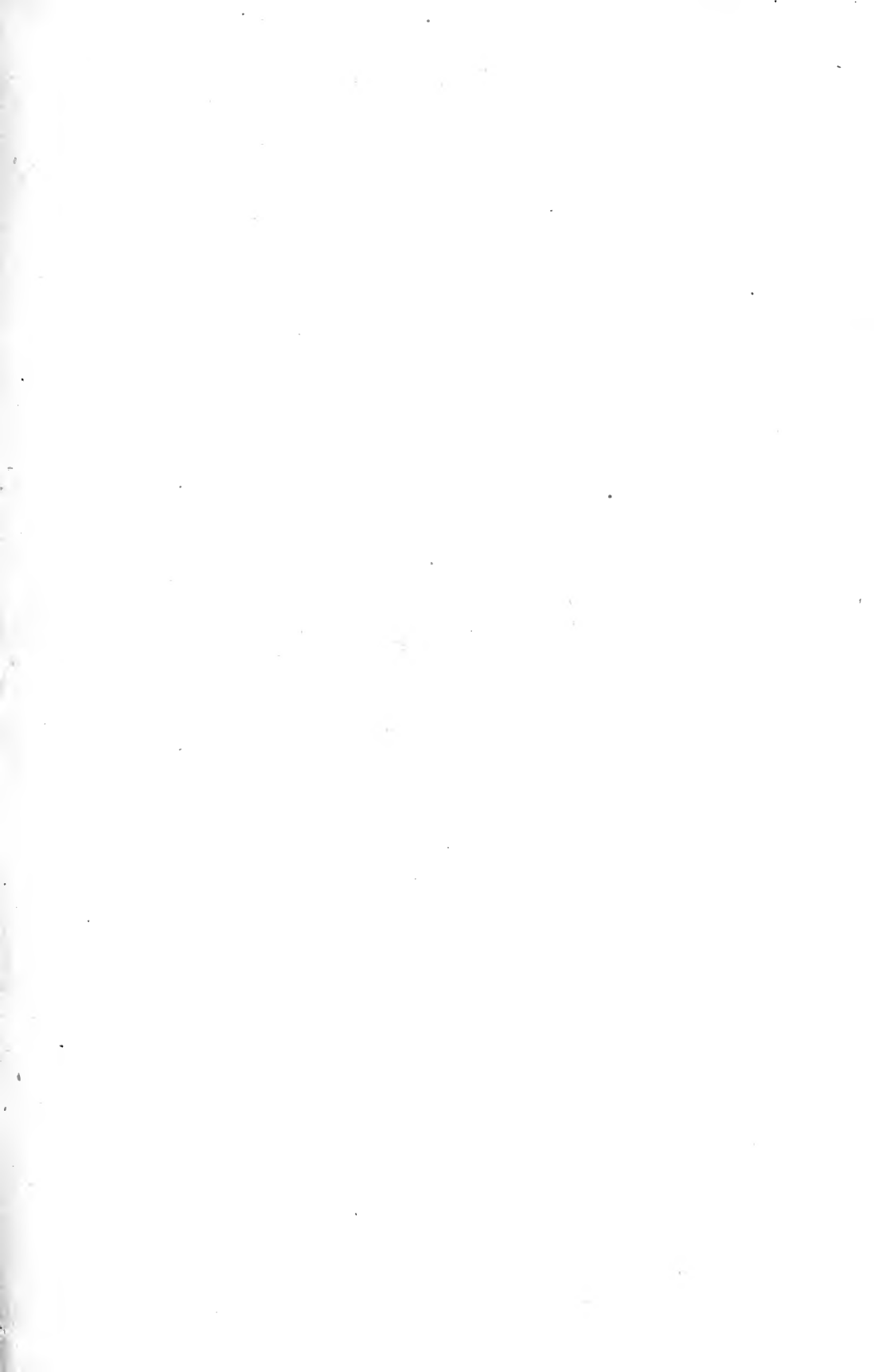

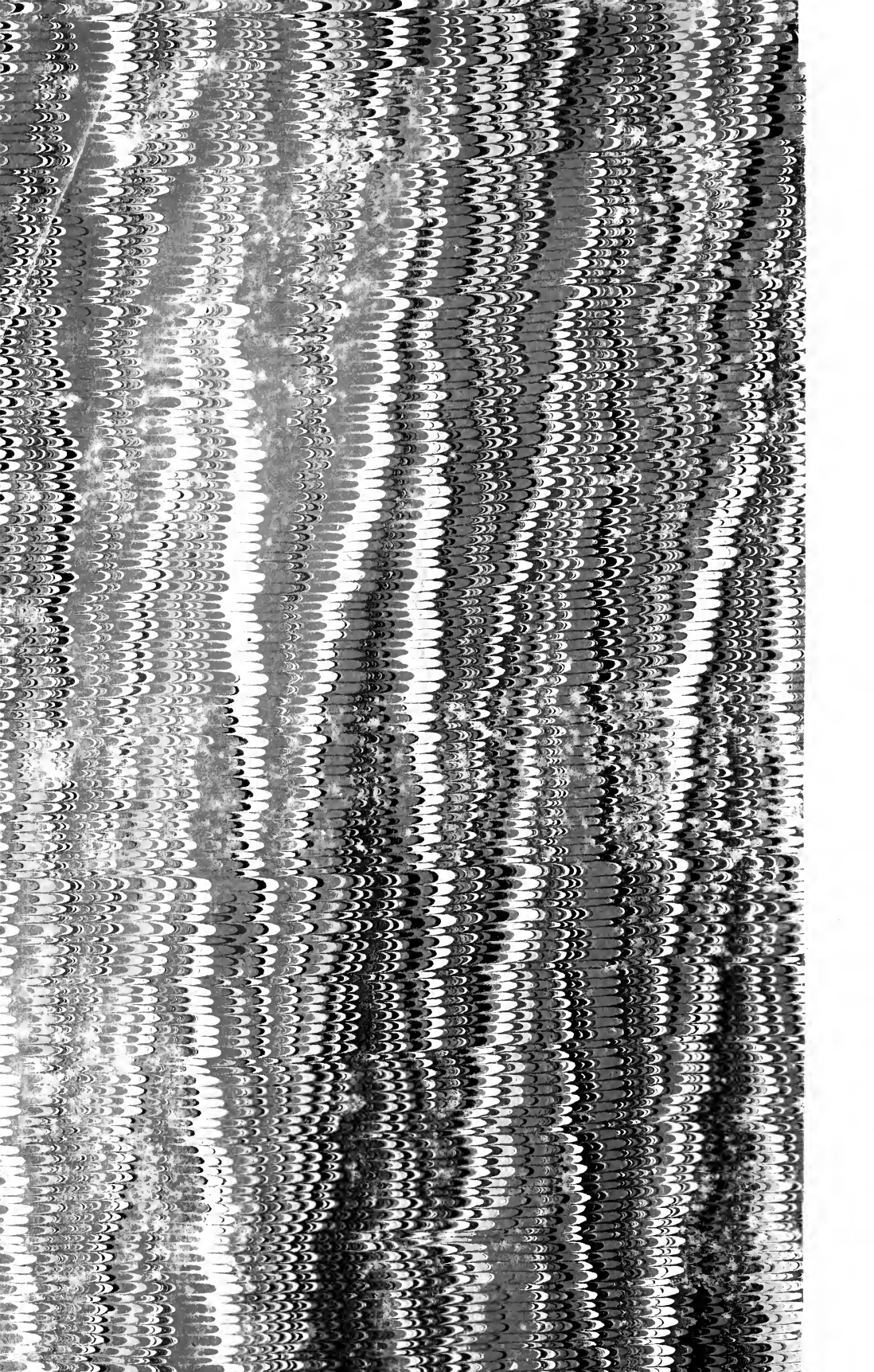



U.C. BERKELEY LIBRA



C020866048

UNIVERSITY OF CALIFORNIA LIBRARY

