

TRACK DEFORMATIONS

UC-NRLF



\$B 79 274

LIBRARY
OF THE
UNIVERSITY OF CALIFORNIA.

Class

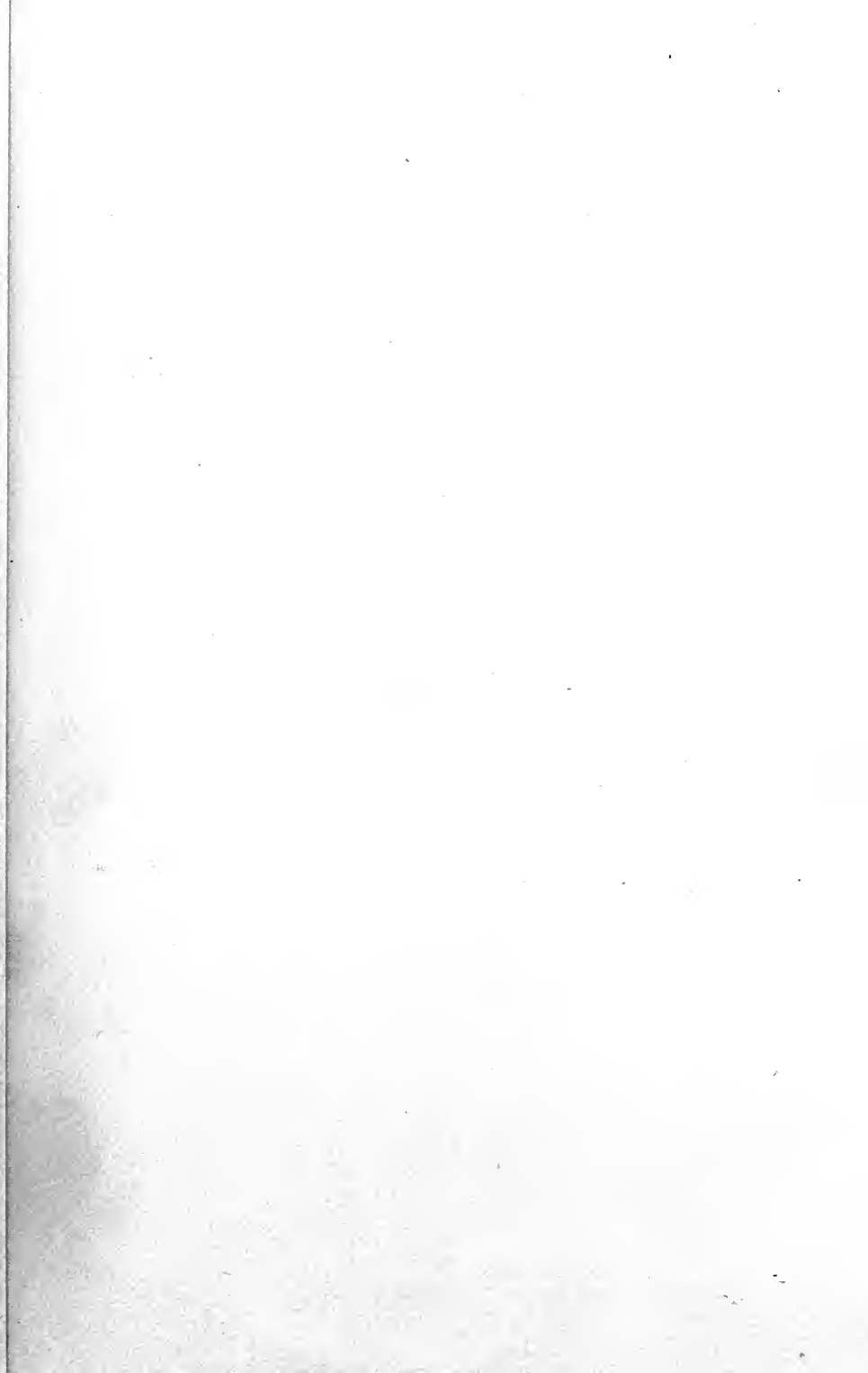

Deformations of Railroad Tracks and the means for remedying them

by

G. CUËNOT

Chief Engineer of Bridges and Highways

Attached to the Board of Control of the Paris-Lyons-Mediterranean
Railroad Company.

Authorized Translation

by

W. C. CUSHING, M. A., B. S.

Chief Engineer of Maintenance of Way
Pennsylvania Lines West, South-West System.



1907.

THE RAILROAD GAZETTE

NEW YORK: 83 Fulton Street CHICAGO: Old Colony Building

THE RAILWAY GAZETTE

LONDON: Queen Anne's Chambers, Westminster, S. W.

17211
C9

GENERAL

Copyright, 1907,
by
THE RAILROAD GAZETTE.

To Mr. Noblemaire, the Eminent Director of the P. L. M. Co.

I have the honor of respectfully dedicating this study, in recognition of the very courteous reception which I have met with among the employees of the company, and of the kind accommodation which Messrs. Rascol, Chief Engineer at Lyons, and Ferry, Sub-Engineer at Bourg, have always accorded to me.





AUTHOR'S PREFACE.

It is evident that railroad travel is about to undergo a considerable evolution. Speeds of 100 and 120 kilometers (62.14 and 74.52 miles) an hour, which were considered as maxima, have been exceeded, by reason of continual progress which has been realized, and which permits a better utilization of energy; we actually talk of engines capable of traveling at a speed of 200 kilometers (124.27 miles) per hour. Some experiments have been lately made in Germany on this subject; a speed of 200 kilometers has been easily attained, but it was necessary to reduce it, in spite of all precautions taken, because the track was not in a condition for supporting the forces of all kinds which were developed under the influence of such a speed.

The problem which is proposed is comparable to that of designing armor-plate capable of resisting the shocks of projectiles. When the armor-plate has been found, we are forced to produce a projectile more powerful, and then the armor-plate has to be reinforced. This quasi duel between two contrary objects, the armor and the projectile, will always be pursued; the advantage of one will soon be balanced by the progress of the other, so that we can never know which is master. The same principle holds true in the case of train movement, the speed of which should necessarily increase, while at the same time we must acquire more complete mastery of the energy that creates speed. But progress in locomotive design is restricted by the limitations of the structure which carries the load. We shall only be able to fully profit by the first after we have perfected the second.

The support of the engine comprises, apart from the roadbed, the ballast, the ties and the rails. It must be made more resistant by consolidating, by rendering more rigid, the elements which compose it, for it is very evident that if these elements are susceptible of rendering good service when they are submitted to given forces, they will not necessarily continue to do so when these forces are increased, either by weight of load carried or by speed of trains run.

The time seems to have come, therefore, for making a minute study of the track, to ascertain what forces it is subject to, and how

it can be made stronger. These forces, however great they may be, are generally created as the effect of a continuous series of slight movements—the creeping of rails, inward inclination of rails, bending of the ties, pulling of spikes, etc.—movements which have not always received the attention they deserve. These effects are produced slowly, successively, in such manner that the final result is not very apparent, and that one often neglects to observe the cause and explain it. For example, it is admitted that rails creep in the direction of the travel of the train, the left rail more rapidly than the right one; nevertheless, certain companies maintain that this movement has never been proved. Is it not rather true that the time has never been taken to observe it? But this slow creeping is important by its repetition; it produces a skewing of the ties, and allows the rail to escape from its fastenings, and is the cause, consequently, of high maintenance expenses. In like manner investigation has not yet been made, at least to our knowledge, of the cause of the more rapid creeping of the track to the left than to the right. Numerous reasons have been given, such as the lack of symmetry of the engine, the position of Giffard, etc., but they have never been fully elucidated.

The problems of tie flexure of the length to be given ties in order to produce the least deformation, have been the object of very little research, at least in France. We are contented with continuing the laying and the maintenance of track with the same information and the same methods. These methods are certainly not bad, since they have permitted the operation of the railroads, after the manner with which we are familiar, to general satisfaction. But if traffic is going to be moved more rapidly without lessening the degree of safety, these methods are going to prove unsatisfactory. There is no doubt that we can have much higher speeds than those to which we are accustomed, but the track as now constituted is not strong enough to carry them.

I have had the good fortune, since the commencement of my career, to be occupied with railroad questions, and for the five years that I have been attached to the service of the Board of Control of the P. L. M. Co., I have studied these questions for myself; making frequent journeys on foot, watching trains pass, and noting all which appeared to me interesting. I have, moreover, conversed with many trackmen, and have often seen the justice in their observations.

In the present study I shall summarize information obtained in such conversation—information difficult to obtain from any but

direct sources. I am inclined to mistrust general inquiry made by writing; it usually produces no result, unless care is taken to distinguish information obtained from conscientious employees from that which comes from the less careful ones, the latter having the tendency to substitute their opinion for the actual facts. Both types of employees are capable of being useful in practical service, but are not equally endowed with the critical spirit and the spirit of observation. This sense is quite rare, and if the critic does not succeed in distinguishing it, he finds himself in the presence of information so contradictory that he does not know how to draw from it what is useful.

It is also necessary to request observations from employees who have apparatus for measuring, and who have placed bench marks in their district, enabling them to fix in plan, as in elevation, the points which they designate. A simple estimate by an employee, however intelligent he may be, is never worth as much as a figure, or a fact well determined and met with a great number of times. I will give an example, of which I have lately been a witness. A track employee, questioned by one of his chiefs on the length to be given to the tamped-bed of a tie, replied, without hesitation: "The best length is 25 centimeters (9.84 in.) on both sides of the rail." This reply, made with great authority, would seem to be peremptory. After the experiments which I had had made, it seemed to me, however, so badly founded that I made an investigation. I found out, with certainty, that in this man's district not a single tie was tamped to the amount specified—a fact not occasioned by the ill-will of the trackman, but because this tamped-bed could not be practically realized, as I will show. This employee had simply expressed his personal idea, and made his chief believe, by the assurance with which he gave it, that such a tamped-bed was possible. Other employees present at the conversation, less positive because they were more careful, spoke of 35 centimeters (13.78 in.) or 40 centimeters (15¾ in.); they were nearer the truth. It is evident that no useful opinion could be found from such contradictory statements of fact, unsupported. Exact evidence is not hard to get; but here again it is a mistake to be satisfied too soon, and it must be remembered that every track foreman has his own methods, founded on experience rather than on rule. It is certainly difficult to make rules of universal application; the local foreman must be allowed some latitude. Tamping varies with gravel and with broken stone, although the limits of variation are so slight that they need not be reckoned here.

In discussing the tamping of ties in the ballast I shall not content myself with presentation of statements or opinions, but will show facts developed under my own supervision, since one is best qualified to speak of the things that he has seen himself. I have been able to make a large number of such observations, and collect a great many instances for comparison, especially as regards ties. Apart from the ordinary wood tie, I have also experimented with a steel and wood composite tie, and with the steel tie employed on the State System of France. From comparisons thus obtained I have been able to deduct precise rules which I would certainly not have been able to do by working in any other manner.

It must be kept in mind that a similar study has been previously made in France by engineers of the highest repute, Messrs. Couard and Freund. The studies which I have pursued have confirmed and made exact the results obtained by these engineers. If I have been able to go further than they, and to present firmer conclusions, it is because I have had at my disposal means of comparison which they lacked, but I have entirely verified the exactness of the observations which they have made, and I appreciate fully the conscientious work which they have done.

I have, therefore, confined myself to the experimental method supplemented by explanations derived by calculation from experimental data. This is the opposite method to that employed by the German engineers, Messrs. Winckler, Ast and others, who have started from hypotheses not verified by experiment and have deduced facts from them by calculation, which they have taken as established without discussion. They have even subordinated observations based upon experiment to the results of such calculation, and have not hesitated to conclude that these observations could not be exact, since they diverged from the calculated results. I believe that this method can produce nothing useful, but that, on the contrary, by rejecting conscientious experiments, it ends in false conclusions. Results based on hypotheses, however ingenious they may be, can have no more value than the hypotheses from which they are derived. Moreover, the study of track is an extremely complex thing; the reactions of the sub-soil, ballast, ties and rails are many and confusing, and they become complicated with each other and distorted to such a degree that they cannot be expressed in terms of simple relation.

To co-ordinate observations which I have myself gathered; to seek to derive a law—not a mathematical, but physical—which binds them up together as well as possible; this is the end which

I have in view. To supplement this, it is only necessary to follow the instructions given by Mr. Couard in his very interesting studies of track, known to all who occupy themselves with this subject.

I wish also to state that I have been very earnestly aided by the engineers and employees of the P. L. M. Company, all carefully selected men, notably by Mr. Ferry, Assistant Engineer at Bourg, who is endowed with unusual powers of observation. For nearly forty years Mr. Ferry has accumulated facts; not merely superficial observations which serve only to confuse, but careful results which make it possible to supply figures and instances to the support of an opinion. I have the greatest desire to continue the study of these track deformations, themselves almost infinitely small, but having an effect comparable to that of tiny microbes on the human organism. At this time, when it is imperative that track should be made more rigid to respond to new traffic conditions, this branch of study increases in importance, and will alone furnish a means of combating these small movements of the track which, isolated, are of small importance, but with sufficiently frequent repetition disorganize the carrying power of railroad superstructure.

I do not pretend in the present work to have studied completely these movements. I realize that there is yet much to do, and I shall be extremely glad if others, still better fitted than I am, shall become interested in continuing this study and in adding a new collection of observations to those which I have made.

G. CUËNOT.

TRANSLATOR'S PREFACE.

The question of the proper length to be given to cross ties has been before the American Railway Engineering and Maintenance of Way Association for the past two years, and, doubtless, the same question has been presented to maintenance of way officers by the managers of their companies in the hope of buying at less cost an article of supply which is ever increasing in price, and at the same time is such a necessary part of the construction of a railroad.

Up to the present time, the problem has not been very scientifically treated in the United States, and there is some divergence of opinion relative to the matter, usually based on the practice under which the individual expressing it has grown up.

Upon reading the account, therefore, of Mr. Cuënot's painstaking experimental work, it occurred to the translator that the description and results would be interesting to the English speaking engineers who are occupied with such questions in their own work, and he therefore made arrangements with the author for introducing the work to them. The author has been very kind and liberal in the transaction, by reason of his truly professional and scientific spirit, and the translator takes this opportunity for expressing his appreciation.

American engineers can learn a lesson for themselves from the scientific spirit and great care with which their foreign colleagues attack a problem to be solved and carry on the work of investigation and experiment.

W. C. CUSHING.



Track Deformations and Their Prevention.

CHAPTER I.

NATURE AND OBJECT OF EXPERIMENTS.

The Minister of Public Works expressly charged me with experimenting with a composite cross tie (wood and steel), and to make him a report on the result of the experiments. I did not believe that it was sufficient to place a cross tie in the track and to observe the manner in which it behaved. It seemed to me that, in order to discuss with some competence the results of the experiments, it was necessary to examine what takes place in the case of a normal track provided with ordinary cross ties or with steel cross ties employed on the State System, and to compare the results obtained with those which were found in the case of the same track provided with composite cross ties.

It was a question then of a collection of tests bearing on all the movements to which the track is submitted, and of the study of all the deformations to which it is subjected. The manner in which the fastenings behaved, with the systems tried, ought also to have my attention; it was interesting to give an account whether or not the methods of fastening (employment of treenails) would be able to render the service on which one has a right to count. The outline of the study, which we have undertaken, comprises nearly all the questions concerning the track, including the joint, which has given occasion for numerous solutions.

It has been possible up to the present time to study the influence of reinforcement of the track by the enlargement of section of rails, of screw fastenings, and of rail joints, but I do not believe that any one has, up to the present, examined the influence of a stronger section given to the cross tie. This study presented then, apart from the special mission which had been intrusted to me, a general interest which I immediately recognized, and which will, without doubt, justify the relatively important work which I have done.

TRANSLATOR'S PREFACE.

The question of the proper length to be given to cross ties has been before the American Railway Engineering and Maintenance of Way Association for the past two years, and, doubtless, the same question has been presented to maintenance of way officers by the managers of their companies in the hope of buying at less cost an article of supply which is ever increasing in price, and at the same time is such a necessary part of the construction of a railroad.

Up to the present time, the problem has not been very scientifically treated in the United States, and there is some divergence of opinion relative to the matter, usually based on the practice under which the individual expressing it has grown up.

Upon reading the account, therefore, of Mr. Cuënot's painstaking experimental work, it occurred to the translator that the description and results would be interesting to the English speaking engineers who are occupied with such questions in their own work, and he therefore made arrangements with the author for introducing the work to them. The author has been very kind and liberal in the transaction, by reason of his truly professional and scientific spirit, and the translator takes this opportunity for expressing his appreciation.

American engineers can learn a lesson for themselves from the scientific spirit and great care with which their foreign colleagues attack a problem to be solved and carry on the work of investigation and experiment.

W. C. CUSHING.



Track Deformations and Their Prevention.

CHAPTER I.

NATURE AND OBJECT OF EXPERIMENTS.

The Minister of Public Works expressly charged me with experimenting with a composite cross tie (wood and steel), and to make him a report on the result of the experiments. I did not believe that it was sufficient to place a cross tie in the track and to observe the manner in which it behaved. It seemed to me that, in order to discuss with some competence the results of the experiments, it was necessary to examine what takes place in the case of a normal track provided with ordinary cross ties or with steel cross ties employed on the State System, and to compare the results obtained with those which were found in the case of the same track provided with composite cross ties.

It was a question then of a collection of tests bearing on all the movements to which the track is submitted, and of the study of all the deformations to which it is subjected. The manner in which the fastenings behaved, with the systems tried, ought also to have my attention; it was interesting to give an account whether or not the methods of fastening (employment of treenails) would be able to render the service on which one has a right to count. The outline of the study, which we have undertaken, comprises nearly all the questions concerning the track, including the joint, which has given occasion for numerous solutions.

It has been possible up to the present time to study the influence of reinforcement of the track by the enlargement of section of rails, of screw fastenings, and of rail joints, but I do not believe that any one has, up to the present, examined the influence of a stronger section given to the cross tie. This study presented then, apart from the special mission which had been intrusted to me, a general interest which I immediately recognized, and which will, without doubt, justify the relatively important work which I have done.

The rails employed were of the type used on the Paris, Lyons & Mediterranean, either the P. M. type of a weight of 39 kilograms per running meter (78.6 lbs. per yd.), or the P. L. M.-A. type, of a weight of $34\frac{1}{2}$ kilograms per running meter (69.5 lbs. per yd.).

The rail joint was made up of angle bars. The screw spikes, No. 6, had a diameter of 20 millimeters ($\frac{51}{64}$ in.). Between the rails and the cross ties are metallic plates of the type used on the P. L. M.

All my experiments, during nearly three years, have been made, first on a side track, then on track No. 2 of the line from Mouchard to Bourg, traversed by the express and fast trains, comparatively with oak cross ties employed on the P. L. M. system, and with composite cross ties (wood and steel). Finally, a special track for experiments was laid at the Bourg station, and there was tested, at the same time as the two types of cross ties recited, the metallic cross tie in use on the State System.

But before making these tests known it is essential to describe the cross ties employed.

The wooden cross ties of wood were oak, creosoted, and of the following dimensions:

Length	2 m. 60 (8 ft. 6.36 in.)
Width	0 m. 22 to 0 m. 25 (8.66 in. to 9.84 in.)
Depth	0 m. 14 to 0 m. 15 (5.51 in. to 5.91 in.)

Composite cross tie, system of Devaux, Michel and Richard.— This is composed of a metallic skeleton in the form of an inverted trough, provided in the interior with two symmetrical blocks of wood solidly fixed, and leaving between them an empty central space.

The upper surface of the skeleton presents, on removal of the track, two rectangular openings, leaving exposed on the blocks the seatings intended to receive the supporting plates for the rails. It is at once seen that this plan of cross tie permits the use of ordinary screw spikes as the method of fastening for the rails.

The metallic skeleton is of the type of iron section known in commerce under the name of Zorès iron, as the section AB shows it. The trapezoidal section is of interior dimensions:

Width at base	0 m. 22 (8.66 in.)
Width at top	0 m. 14 (5.51 in.)
Depth	0 m. 135 (5.32 in.)

The thickness of the metal ought to be 5 m/m ($\frac{13}{64}$ in.) but in reality it is only 4 m/m $\frac{9}{10}$ ($\frac{3}{16}$ in.), and the total length is 2 m 50 (8 ft. 2.4 in.). In later experiments the length was reduced to 2 m 20 (7 ft. 2.64 in.). The side walls terminate in a flange

along the lower edges. The object of this arrangement, which is found in the greater number of metallic cross ties, is to render the cross tie better able to resist the blows of tools during tamping, to increase the moment of inertia in the vertical direction, and also to permit the clamping of the cross bars.

The metallic skeleton is provided in its lower part with four cross bars, two under each block. These cross bars are fixed without bolts or rivets, their extremities are simply curved and clamped on the flanges of the skeleton. Their object is to hold together the side walls of the metallic envelope, and to thus insure the wedging of the blocks in the interior of this envelope. The metallic part weighs about 60 kilograms (132.28 lbs.).

Each wooden block is composed of three wedges joined together, whose dimensions are given by the sections AB and CD.

The rails are fixed on the blocks through the intermediary of a plate with shoulder, by means of ordinary screw spikes. The supporting surface of the plate is inclined at $\frac{1}{20}$ in order to give the desired inclination to the rail, and the mortise is made in such a way that the plate should be well supported on the exterior side of the track by the corresponding edge of the notch in the metallic skeleton in order to oppose, in case of need, all lateral movement. The object of this arrangement is to prevent the spreading of the track, to which there is a tendency on curves.

The heads of two screw spikes of each middle wedge press the rail on the cross tie, and ought to act strictly as an adjusting screw on the middle wedge; for this effect a play of about 10 m/m ($\frac{25}{64}$ in.) is taken up between the upper face of the wood and the bottom of the metallic skeleton.

This arrangement allows a strong pressure of the lateral wedges against the sides of the skeleton to be obtained, a pressure which the passage of trains only increases by reason of the reaction of the ballast, which tends to push up the blocks and press them against the lateral walls.

The three wedges as a whole form, under pressure, a true block, solidly maintained by the metallic skeleton and the cross bars, and under which one can tamp as under a wooden cross tie.

It has been recognized in the course of experiments that the wooden part was like a monolith; that the middle wedge once in place could no longer be pushed up, which, upon the whole, is an advantage, and inventors have substituted for the three wedges a single wedge pressed into the skeleton by means of cross bars, presenting, besides the advantages of the three-wedge system, a

better supporting surface for the plate, and the possibility of employing the chair for track with double headed rail. This latter system offers, besides, easier methods of manufacture.

The length of either of the blocks is regulated by the conditions under which they distribute the pressure on the ballast; it is about 0 m 70 (27.56 in.), a length which has been recognized as sufficient to assure the bed of the cross tie on the ballast.

The separate wedges of the blocks are cut by saw, according to patterns made with care, so as to fit exactly in the interior of the skeleton.

The shoeing (adzing and fastening the plates to the ties) can be done by machine by previously confining the blocks in a special matrix, which will hold them under the tools of the planers in the desired place and afterwards serve for drilling the holes for the screw spikes, by the aid of augers driven by steam.

The blocks weigh about 32 kilog. (70.55 lbs.), and the weight of the cross tie is nearly 78 kilog. (171.96 lbs.).

The steel cross tie used on the State System is also shown in the section herewith, to the right of Zorès Iron. It is 2 m 50 (8 ft. 2.4 in.) long and weighs 58 kilog. (127.87 lbs.).

The various characteristics of the cross ties experimented with are summarized in the table on the following page.

The composite cross tie is from $1\frac{1}{2}$ to 3 times as rigid as the wood cross tie, even at the notches prepared for the seating of the tie plates, varying according to whether the part notched, which is the weakest section, or the armored metallic part is considered. This cross tie is also 2 to 4 times as rigid as the steel cross tie of the State Railroads.

It is possible to give an account in another way of the difference in resistance of the beams considered. In fact, if the condition is imposed that their deformation be the same for a like force, that is to say, that they each take an equal elongation, it is found, by designating L this elongation, by R , R' , R'' , the stress per unit of surface of these beams, E , E' , E'' , the coefficient of elasticity of the material of which they are made:

$$L = \frac{R}{E} = \frac{R'}{E'} = \frac{R''}{E''}$$

whence is deduced, by representing by $\frac{I}{Z}$ their moment of resistance, which is inversely proportional to R :

$$\frac{EI}{Z} = \frac{E'I'}{Z'} = \frac{E''I''}{Z''}$$

CHARACTERISTICS OF CROSS TIES EXPERIMENTED WITH.

1	2	3	4	5	6	7	8	9	10	11	12
Designation of the cross tie.	Resistance to extension, per cm. ²	Elongation to elastic limit, per cent.	Weight of the cross tie in kilos.	Width of surface, in cm.	Thickness in centim.	Length in meters.	Moment of inertia in cm. ⁴ .	Of re. in cm. ³ .	Position of neutral axis in centim.*		Rigidity of the cross tie.
Oak cross tie	200	2	70 (154.3 lbs.)	22 (8.66 in.)	14 (5½ in.)	2.6 (8 ft. 6.36 in.)	5,030	718	7.0	7.0	503,000,000
Modulus of elasticity of wood: E = 100,000.											
Composite cross tie	Steel. 3,100 ¹	22	46 (101.4 lbs.)	2.5 (8 ft. 2.4 in.)	533	61	5.24	8.76	821,000,000
	Wood 200	2	32 (70.5 lbs.)	25 (9.84 in.)	14 (5½ in.)	..	229 ²	29	6.05	7.95	1,429,000,000
In the armored part.....											
In the middle.....											
Right at the fastenings.....											
State cross tie.....											
Modulus of elasticity of steel: E = 2,000,000.											
In the armored part.....											
In the middle.....											
Right at the fastenings.....											
State cross tie.....											
Modulus of elasticity of steel: E = 2,000,000.											

*In reference to the lower and upper planes of the cross tie.

¹ Limit of resistance to rupture, 4,500 kilos.

² Moment of inertia right at the openings in the metallic skeleton.

³ Right at the openings.

⁴ Right at the furrings (blocks).

⁵ At the extremities and in the central part.

⁶ These figures have reference to the neutral axis of the cross tie forming a whole with the furring (blocks).

⁷ The beam being supposed of steel.

To appreciate the difference of resistance of cross ties submitted to a like deformation, it will be sufficient to compare between them the products such as $E \frac{I}{Z}$, or else, if the resisting moment of the steel beam is taken for a term of comparison, it will be necessary to multiply $\frac{I}{Z}$ by the ratio $\frac{E'}{E}$. The following results are thus arrived at:

Comparative resisting moments of different cross ties supposed of steel.

Cross-tie of wood.....	36
Composite cross tie:	
In the armored part	87
In the middle and at the extremities.....	61
Right at the fastenings	60
Steel cross tie of the State	30

The part of the metallic skeleton cut out to permit fixing the fastenings on the wooden blocks, which is necessary for the placing of the plate, or the chair, is of short length, about 0 m 15 to 0 m 30 (5.91 to 11.81 in.). This weakening is compensated, and more, by the plate, or chair, which forms part of the armored beam.

The above results have been obtained while seeking the mean coefficient E of the armored part by the condition $EI = \sum ei$, E being the coefficient of elasticity of the two materials considered, I their moment of inertia, $I = \sum i$; and the neutral axis of the composite beam being determined by the condition that each element is stressed proportionately to its coefficient of elasticity.

The composite cross tie offers, then, in all its sections, a resistance superior to that of the steel cross tie of the State; it will then be stressed much less and will be more resistant, under much more advantageous conditions.

EXPERIMENTS ON THE SIDE TRACK AT BOURG-EN-BRESSE.

The object of these first experiments was to ascertain the stability of composite cross ties and observe the manner in which the blocks behaved. It was essential to be assured of these two points before placing them in a main track.

The metallic skeleton of the composite cross ties was made of soft steel coming from dephosphorized meltings, and its form obtained by hammering.

The blocks were cut with a saw from new cross tie timber, but from waste which could not be otherwise utilized. The elements of 50 composite cross ties were thus obtained; 46 were made of oak

and 4 of beech. The wood was injected with creosote at the workshop of the P. L. M. Co., at the station of Perrache 2.

These 50 composite cross ties were placed in track 5 at the station of Bourg-en-Bresse. Their spacing, with three fastenings, two were exterior and one interior, was one meter ($39\frac{3}{8}$ in.), except at the joints of the rails, five meters long (16.40 ft.), where the spacing was reduced to 0 m 70 (27.56 in.) and 0 m 60 (23.62 in.).

This laying was done on February 3, 1902, at a period little favorable for making track. The earth was covered with snow, and it was necessary to break up the subsoil in order to proceed with the laying of the experimental cross ties. In spite of these unfavorable conditions, it was only on the 13th of March following that the first repair was made, consisting of a general tamping necessitated by the thawing, and at the same time of a raising of all the track. Since then it has not been retouched.

When the cross ties were brought to their place, the plate was placed above the blocks, and the two fastenings of the central wedge were tightened alternately to avoid any dislodgement of that piece.

The ballast in track 5 was rough gravel; one of the cross ties, provided with two sections of rail, was placed apart from the tracks in broken stone in order to see in what fashion the pieces of wood would behave in that ballast. The metallic skeleton was left visible in the interior of the track, except for 12 cross ties, which were covered by ballast.

From the time of their placing, the cross ties were subjected to the successive effects of heavy rains, which have lasted during the greater part of the spring, and of excessive heat, which has ruled during the summer.

We examined at different visits the condition of the track, and found each time that the condition was excellent; that notably the fastenings were always thoroughly tight, and that the passage of the heaviest engines (102.5 net tons, including the tender and the load of water and coal,) did not cause any apparent deflection of the metallic part binding the two lines of rails.

About 40 engines per day passed over the track, which represents a total passage of 1,200 per month, and of 7,200 during the six months of experiments, reaching to the 3d of August.

Before proceeding with the experiments on the resistance of fastenings, we took the track to pieces and removed some cross ties. We found that the tamped bed under the ties was absolutely intact; that the wood offered no trace of crushing, and that the

tightening of the wedges was absolute; that the central wedge had not been raised by the tightening of the screw spikes, and that the allowance existing after placing was maintained without variation, as is shown in the table below:

Number of cross-ties.	Interval included between the bottom of the —plate and the upper face of the wedge—			
	—To right of axis—		—To left of axis—	
	Millimeters.	Inch.	Millimeters.	Inch.
26	3	$\frac{1}{8}$	6	$\frac{1}{4}$
27	15	$\frac{19}{32}$	12	$\frac{15}{32}$
28	10	$\frac{13}{32}$	10	$\frac{13}{32}$
29	6	$\frac{1}{4}$	5	$\frac{3}{16}$
30	3	$\frac{1}{8}$	10	$\frac{13}{32}$
31	10	$\frac{13}{32}$	10	$\frac{13}{32}$
32	20	$\frac{25}{32}$	20	$\frac{25}{32}$
33	12	$\frac{15}{32}$	10	$\frac{13}{32}$
34	15	$\frac{19}{32}$	5	$\frac{3}{16}$
35	8	$\frac{5}{16}$	14	$\frac{9}{16}$
36	5	$\frac{3}{16}$	8	$\frac{5}{16}$
37	15	$\frac{19}{32}$	7	$\frac{9}{32}$
38	12	$\frac{15}{32}$	14	$\frac{9}{16}$
39	12	$\frac{15}{32}$	12	$\frac{15}{32}$
40	17	$\frac{21}{32}$	16	$\frac{5}{8}$
41	16	$\frac{5}{8}$	22	$\frac{7}{8}$
42	15	$\frac{19}{32}$	13	$\frac{1}{2}$
43	12	$\frac{15}{32}$	17	$\frac{21}{32}$
44	21	$\frac{27}{32}$	18	$\frac{23}{32}$
45	16	$\frac{5}{8}$	19	$\frac{3}{4}$
46	20	$\frac{25}{32}$	18	$\frac{23}{32}$
47	16	$\frac{5}{8}$	17	$\frac{21}{32}$
48	14	$\frac{9}{16}$	18	$\frac{23}{32}$
49	9	$\frac{11}{32}$	17	$\frac{21}{32}$

The composite cross ties which were placed at the Bourg station were replaced in the month of January, 1903, (from the 5th to the 8th) in compliance with the ministerial decision of December 12, 1902, in track 2 of the line from Mouchard to Bourg* between kilometers 494,417 and 494,465 in proximity to the station of Saint-Etienne-du-Bois, above an embankment of argillaceous nature, about 1 m 50 (4.92 ft.) in height. This part of the line is located at the origin of a curve of 600 meters (1,968½ ft.) radius, following a tangent alinement of 6,604 meters (21,666.6 ft.) long, at the extremity of a series of grades (4 m/m 6, 9 m/m 5, 2 m/m 8) (0.47, 0.94, 0.28 ft. per 100), which follows a level. It resulted from this situation that the cross ties were at a point where water accumulates and causes the ballast and the embankment on which it rests to soften. The ballast came from the Ambronay quarries (near Ambérieu). It was composed, like the greater part of quarry gravel, of silico-calcareous gravel and of loam in quite a large quantity. The char-

*This line is used by fast trains, such as the Berlin-Nice and the Indian Mail; the mean density of traffic of this line is about 20 trains a day on each of the tracks.

acteristic of this ballast is to form a conglomerate very hard in dry weather, and in wet weather to make a sort of mud more or less fluid, according to the moisture with which it is impregnated.

The cross ties were placed at the rate of 12 cross ties per rail length of 8 meters (26.25 ft.) of the P. M. type, weighing 39 kilogs. per running meter (78.6 lbs. per yd.), over 4 lengths of rail. This type of rail was chosen because the width of its base was adapted to a plate whose dimensions were precisely those of the notch.

The rails thus employed had been taken from the track after a long service*, which explains their exceptional deformation (see Fig. 3) and made conspicuous by the unevenness of 3 millimeters ($\frac{1}{8}$ in.) which they present in a short length (about 1 meter) ($39\frac{3}{8}$ in.). They rested on the cross ties, as we shall see further along, by means of P. M. plates; the fastenings placed unsymmetrically, and composed of screw spikes No. 6, were to the number of 8 per cross tie, 2 outside and 2 inside each of the rails. There was placed at the beginning, and at the extremity of the track thus laid on composite cross ties, a length of rail of the P. M. type on wood cross ties with the same laying, in order to be able to establish a comparison.

All of these cross ties were inclined toward the center of the curve of 600 meters (1,968 $\frac{1}{2}$ ft.) radius turning to the right, with a superelevation of 0 m .083 ($3\frac{3}{32}$ in.). This inclination had further the disadvantage of throwing all the surface water of the track in the inter-track space, where it was held by the impermeability of the ballast.

Left under these conditions for more than a year, the cross ties have been submitted to the successive effects of heavy rains, which lasted during a large part of the time, and of the period of warm weather.

The condition of the track was examined at different visits, and it was proved each time that the condition was excellent; that there was never occasion for retightening the fastenings, and that the cross ties under the passage of trains (about 8,000) did not undergo any apparent bending. Thus there was placed on the composite cross ties, the same as on the neighboring wood cross ties, a bed of gravel over the whole surface; it was proved that not a grain of gravel was detached by the passage of express train 682 from the edges of the composite cross ties, whilst there existed

*These rails had endured a density of traffic of 150,000 trains; we had not been able to find new rails of the same length in the stock of the company.

cracks in the surface of over a third of the wood cross ties. This difference in the stability of the gravel evidently arises from the pronounced bending of the wooden ties.

As a result of the super-elevation and grade, argillaceous nature of the ballast and of the subsoil, the composite cross ties, principally those of the even-joint, rested on a muddy bed, and the water visibly churned at the passage of each train. This bed was then essentially elastic, and this elasticity varied with the quantity of water. The cross tie was not unwedged, as one would suppose, for it always rested on its blocks, which were buried more or less considering this condition. The wood cross ties were found in nearly the same situation, with this difference, however, that their bed was more solid by reason of the ballast being less argillaceous.

On the other hand, the defective profile of the rails employed, which has been pointed out above, produced disagreeable unevenness in the stability of the cross ties which underwent the shocks. The joints were particularly bad in consequence of the flattening of the ends of the rails, to such an extent that it was necessary to sustain them by wedges placed between the splices and the under part of the rail head; these defects were but little corrected. The experiment was therefore made under the most unfavorable conditions, but, nevertheless, the results obtained have been excellent. The fastenings have held without our having been obliged to re-touch them. The tamping was maintained on a horizontal bed over the whole length of the blocks, whilst it has a tendency to form under the wood cross ties either a concave basin, on the edges of which they rest in a state of repose, or a convex cap, on the summit of which they find support. The rewedged joints no longer presented a sensible unevenness at the passage of vehicles; the rolling was then very much improved.

Mr. Ferry, Sub-Engineer of the company, had caused a track to be extended in a cul-de-sac of the Bourg station, along the loading quay for animals, in order to permit experiments on the length of cross ties and of their tamped bed, and to join them with the tests executed up to that day, by means of loads perfectly defined, acting always under the same conditions.

The subsoil, specially cleared away for the laying of the track, consisted of an argillaceous conglomerate, enclosing small pebbles of gravel; it was not therefore perfectly homogeneous. The ballast was fine gravel. There were successively placed in the track thus established composite cross ties, wood cross ties and cross ties wholly metallic.

In order to be able to better appreciate the difference of stability of composite and wood cross ties, and to eliminate all influences on this stability, independently of their own resistance, such as inclination on the curves, the elasticity of the road bed, and the argillaceous nature of the ballast, we deemed it a duty to remove the cross ties which were laid, as we have pointed out, below the station of Saint-Etienne-du-Bois, and to put them above at the entrance of that same station, on tangent, on a very solid road bed, and finally to ballast them with gravel purged as much as possible from clay. I had, in advance, the ends of the cross ties cut off, in order to leave them exactly of the length of 2 m 20 (7 ft. 2.64 in.), corresponding to the minimum bending, and to the distance between the extremities of the blocks. The metallic skeleton projected, in fact, beyond the wood by 0 m 15 (5.91 in.) at each end, and this excess of length was quite useless.

The wood cross ties were laid at each of the extremities of the section thus selected to serve for terms of comparison. They were of the ordinary dimensions and length. All these cross ties were provided with P. M. rails, absolutely new, whose rolling surface was consequently as good as possible. The ends of the rails laid on composite cross ties were joined by ordinary splices; on the wood cross ties, angle bars were used.

When the track had taken its bed, the curves of flexure of the cross ties were determined anew; then account was taken of their tamping and of their depression in the track after the passage of the same number of trains. Finally the study of the joint, so interesting and so difficult, was commenced.

These experiments, which have already been pursued for a year, have not yet sufficiently advanced for me to have made known the results. I can, however, already affirm that everything has happened as I had foreseen, and that the composite cross ties of 2 m 20 (7 ft. 2.64 in.) have a stability in the track much superior to that of the ordinary cross ties, other things being equal. That is due to their greater rigidity and to the tamped bed which is maintained in the condition in which it was placed.

It will be interesting, after a longer period in the track, to make known and explain the facts which will be found.

CHAPTER II.

MOVEMENTS TO WHICH TRACK IS SUBJECTED.

The tracks, made as has been explained, have permitted the study of the principal movements to which they are subjected, and which cause their deformations; they are produced in a longitudinal direction, in the direction of the travel of the trains, and in the transverse direction.

It is important to analyze them with care, in order to seek the means for remedying them.

LONGITUDINAL MOVEMENT.

The weight on the wheel is distributed over a certain number of cross ties, and imposes on them a vertical movement, directed at first from low to high, then from high to low, when the load is brought near.

Mr. Couïard has recorded these facts by means of the apparatus of Marey, and has derived from the experiments which he performed in June, 1903, between Melun and Bois-le-Roi, the following conclusions:

When the first wheel of the engine is at 6 meters (19.68 ft.), the movement of the cross tie, from low to high, begins.

When the first wheel of the engine is at 3 meters (9.84 ft.), the displacement is maximum.

When the first wheel of the engine is at 2 meters (6.56 ft.), the movement from high to low below the initial position begins.

When the wheel is on the cross tie the depression of the tie reaches its maximum.

But these figures are only averages, and the mean distance of 2 meters (6.56 ft.), from which place the depression of the cross tie in the ballast commences, goes on increasing from the advance to the following end. It follows that the bending rail in its first half, over shorter length, ought to curve more in that part.

Mr. Ast, Director of Ways and Cross Ties (Austria-Hungary), by the use of instantaneous photography has confirmed the results and shown, afterwards, that the ballast was compressible and underwent movements analogous to those of the cross tie, although less.

It was our desire to verify the results given by those engineers, and to observe the influence of more rigid cross ties on the vertical movement. We had at our disposal, aside from the wood cross ties in use on the Paris, Lyons & Mediterranean System, the composite cross ties laid as described in one of the main tracks of the line from Mouchard to Bourg. The experiment was made by an engine with three axles coupled weighing 32 tonnes (35.27 net tons) in working order, a tender of 24 tonnes (26.46 net tons), and a car.

This train was moved on a bay provided with ordinary wood cross ties, then on another bay with composite cross ties, each of these bays being comprised between two successive joints. The wood cross ties supported P. L. M.-A. rails, the composite cross ties P. M. rails, having a greater weight and rigidity.

The first axle of the engine was brought as near as possible to the cross tie to be tested. There were marked off, by a special rule and a gage, of which a description will be given further along, when we study the flexure, points on the rail at each cross tie; these same points were retaken at each stoppage of the train, that is to say, each time it advanced a length corresponding to the spacing of the cross ties. The points thus marked off on each rail were joined, for each position of the train, by a full line where it refers to the movement on the track composed of ordinary cross ties, and by a dotted line where it refers to the track with composite cross ties. Each of these lines, represented in Figs. 4 and 5, gives the undulatory movement of the track in each of the positions of the train, when the latter is stopped successively right at each of the cross ties. This movement is quite like that which has been described by Mr. Couïard; when the first wheel of the engine is found at a certain distance (about 6 m.) (19.68 ft.) from a cross tie, the movement from low to high commences; the latter is maximum at 3 meters (9.84 ft.), then it reverses and the cross tie sinks, the maximum corresponding with the passage of the first axle.

The part of the track in which the composite cross ties were placed, was much worse, as has been explained above, than that where the ordinary cross ties were located. The roadbed was less hard and above all the ballast was more moist, more muddy; the consequence of this was that the composite cross ties were not perhaps buried more at certain points than the wood cross ties placed under more favorable conditions; but, as a whole, the profile with composite cross ties is much less accentuated than that with wood cross ties. The rise is much less marked, that is to say, the track as a whole being more rigid, the oscillatory movement

is diminished. The ramps, which the train has to surmount, are less, that is to say, the traction is better and exerts a smaller effort. The joint which is induced from low to high, by the oscillatory movement of the track, and which by this fact is disorganized, as will be seen further along, is not so to speak more affected, when the track is provided with composite cross ties.

The table herewith exhibits the results:

Designation of position first axle of engine.	Ascents to overcome				Movement of the Joint.	
	Ordinary cross ties		Composite cross ties.		Ordinary cross ties.	Composite cross ties.
	10ths of millim.	100ths of an inch.	10ths of millim.	100ths of an inch.		
1	16	6	17	7	1	0
2	18	7	17	7	0	4
3	26	10	20	8	2	4
4	33	13	25	10	1	2
5	43	17	17	7	3	1
6	34	14	14	5	2	0
7	23	9	11	4	2	0
8	17	7	10	4	4	1
9	14	5	17	7	2	3
10	11	4	16	6	0	4
11	6	2	14	5	16	9
12	8	3	6	2	11	11
13	15	6	20	8	0	1
14	16	6	20	8	2	3
15	18	7	19	8	2	2
16	23	9	14	5	3	0
17	23	9	11	4	6	0
18	27	11	8	3	5	0
19	24	10	14	5	6	0
20	14	5	11	4	6	1
21	13	5	7	3	5	1
22	14	5	14	5	6	3
23	1	..	15	6	8	3
24	8	3	7	3	18	13
Total.....	445	..	324	..	106	65
Mean.....	$\frac{445}{24} = 18$	7	$\frac{324}{24} = 13$	5	$\frac{106}{24} = 4.4$	$\frac{65}{24} = 2.7$

NOTE.—The positions from 1 to 12 correspond to the track on the long radius; those from 13 to 24 to the track on the short radius.

In recapitulation, the use of rigid cross ties has diminished the effort of traction in the proportion 13 to 18, that is to say, that the tractive effort on rigid ties is about 30 per cent. less than on the ordinary cross ties. The movement of the joint is reduced by about one-half. The result was indeed what one could expect. It demonstrates the importance of the longitudinal movement, and the advantage of diminishing it by using rigid tracks.

It can be objected that the comparison made is not perhaps entirely exact, since the P. L. M.-A. track, laid with ordinary cross ties, is less rigid than the P. M. track with composite cross ties,

and that everything in the case in hand was combined to obtain a more favorable result. That objection ought to be dismissed, for the influence of the subsoil and of the ballast counterbalanced, and more, the rigidity of the rail.

TRANSVERSE MOVEMENT.

The transverse movement of the track is of still greater importance than the longitudinal movement, and produces more important effects. It arises from this that the cross tie is not only buried in the ballast, but it bends; each of its points seems then to be buried in the ballast by unequal quantities, and this unequal sinking results in the greatest deformations of the track.

Mr. Couïard has studied the question with all desirable care, but his measuring instruments, doubtless imperfect, have not permitted him to draw from his study all the conclusions which should have been derived. The form of the curve of deformation which he has found (*Revue des Chemins de Fer*, July, 1897,) is such that it does not permit the deduction of a general law from the phenomena observed. However, that engineer has found that the vertical displacements of cross ties hardly reach 3 millimeters ($\frac{1}{8}$ in.), and that they are not proportional to the weights supported. He has concluded from it "that the cross ties fixed to the rail remain, at certain points, suspended above the ballast, and that right at the rail there is formed, under even the best tamped cross ties, some depressions of ballast on the edges of which the cross tie is supported; that under the passage of a wheel even lightly loaded, the cross ties come in contact with the ballast and deflect to the depth of the depressions; that from this moment only the importance of the bending is proportional to the load." Basing their study on the theoretical researches of Winckler, some notable engineers, Shwedler, Hoffmann, Lehwald, Riese and Zimmermann, have studied the manner in which cross ties behave when resting on an elastic foundation. They have determined the deformations which they experienced under the effect of a load in repose, and estimated the magnitude of the tensions of flexure which result from it.

If the cross ties were completely rigid there would result a uniform distribution of the pressure on the ballast. But it is not so; the cross tie is unequally buried in the ballast, in such a way that the pressure is no longer uniform, but is greater right at the rails.

The cross tie should, then, be considered as a continuous beam resting on an elastic base unsolved for continuity, and supporting

a vertical load at two points. The German engineers designate by *load on rail* the pressure which the rail exercises on the cross tie, and that pressure depends as much on the transverse section of the rail as on that of the cross ties, as well as on their spacing and on their bedding. They admit, also, that the deformations and the strains experienced by the cross tie vary with the length and nature of the tamped bed.

Starting from these premises, they have found that the elastic curve of a cross tie was represented by Figure 1 or by Figure 2,

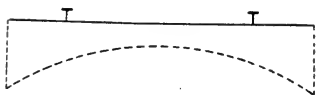

Fig. 1.

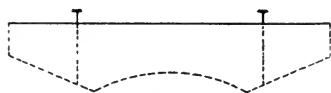

Fig. 2.

according as the cross tie was 2 m 40 (7 ft. 10.4 in.) or 2 m 70 (8 ft. 10.3 in.) long.

The cross tie of 2 m 40 (7 ft. 10.4 in.) would be deformed then according to a convex curve; the maximum of the sinking would be produced at the extremities and would continue diminishing toward the middle. But, with a cross tie 2 m 70 (8 ft. 10.3 in.) long, the maximum sinking would be produced nearly under the rail, and the permanent compression of the ballast would be diminished from this point nearly uniformly on both sides, in such a way that even a deeper sinking would not have as a consequence a change in the inclination of the rails, nor in the spreading of the track.

The theory assumes an absolutely homogeneous cross tie with a tamped bed continuous and uniform over its entire length. The German engineers think indeed that this hypothesis is not realized in practice; they recognize also that short cross ties present in reality a curve of deformation similar to that of long cross ties; but they explain this difference between theory and practice by the stronger tamping of the heads of the cross ties.

The incomplete results given by Mr. Couard, the very ingenious theory of the German engineers, rendered necessary the study of the deformation of a cross tie under a load, of the manner in which the ballast behaves under the cross tie, of its more or less extent of compressibility, of its more or less extent of elasticity. The experiments which have been carried on during nearly two years have had this object as their principal end.

CURVES OF DEFORMATION OF CROSS TIES.

They have taken place under the most different conditions of temperature and humidity, in such a way as to have the terms of comparison numerous, to be able to compare them and to determine an aggregation of facts which may not be controvertible. They have been carried on at three different periods; from the 4th to the 15th of May, during a rainy period, after a prolonged season of rain; from the 19th to the 30th of June, after a drier season, and finally at the end of the month of July, 1903, at a time when the rains had just returned. (I do not give an account of the last experiments, which only confirm the results of those which are given.) In all the tests the ballast, composed as has been pointed out above of rough gravel agglomerated with argillaceous sand, was particularly moist, and consequently muddy. This state of moisture was so great that it was maintained even in the period of heat in the months of June and July. The drying of the ballast was not completed, by reason of the position on a curve, and of the inclination toward the interior of the track, which is the consequence of it (0 m 083) ($3\frac{3}{32}$ in.), the loads were carried on the rail on the side of the short radius. The ballast was therefore more compressed on that side than on the other; its permanent sinking was consequently more pronounced, and it preserved, after the passage of vehicles, the form of a plane slightly inclined toward the center of the curve. The cross tie rested thus toward the extremity of the inclined plane on the side of the long radius; the water accumulated in the lowest part of this inclined plane, that is to say on the side of the short radius. The ballast was therefore particularly wet on that side; it was possible, by making a trench right at the cross ties, to let the water flow off, which rendered the support very elastic. The drop of the vehicles from the advance-rail to the following-rail rendered this effect still more sensible right at the cross ties of the following end of the even-joint; the hammering of the ballast by the shocks of the wheels augmented the depression between the bottom of the cross tie and the upper part of the support, a depression in which the water accumulated. Also, at the passage of vehicles, the water was projected vertically; the cross tie and the rail bore traces of these ejections. This fact was not isolated and peculiar to the part of the track which we studied. Wherever the ballast is but little permeable, and can form a cake more or less firm, the same phenomenon is observed, which shows above all right at the cross ties of the even-

joint (of whatever nature they may be) by the projection of mud on the rail. The hammering of the ballast produces a void under the point of application of the load; this void is filled little by little with the materials of the roadway, which are slowly displaced, falling into the inter-track space or on the outside space, and flowing between the two rails. The ballast is as though screened by the vibration of the cross tie of the following end of the even-joint; the finest materials pass under the rail and cause the coarser materials to ascend in the inter-rail space. In this part of the track it is also remarked that the screw spikes of the cross tie of the following end of the even-joint are subjected to a wrenching, because they support at their lower extremity a hydraulic pressure which expels them from their holes, and that the more rapidly as the insufficiently creosoted wood is submitted to the alternations of dryness and wetness and deteriorates in consequence of the oxidation of the screw spike. In order to have a good track it is very important to select a gravelly ballast purged from earth and above all from clay.

The experiments thus executed in a mediocre ballast, resting on a compressible bed, have then taken place under unfavorable conditions, the results obtained, and the information which will be derived from them will have a bearing which we should not slight.

The most numerous experiments have been carried on in a static state, because it resulted from similar tests made by Mr. Ferry, Sub-Engineer, at Bourg, that the flexures in the dynamic state are not superior to those which are realized in a static state. The curve of deformation of cross ties can be modified in its general form, but its parts preserve the same relation between themselves, maintaining the same flexure as in the static state. This fact has been verified on the wood cross ties provided with P. L. M.-A. rails.

The determination of the curves of deformation of cross ties has been made with extreme care, taking all desirable precautions.

MEASURING APPARATUS FOR EXPERIMENTS IN THE STATIC STATE.

There were first placed in the surface of the wood cross ties screws with square heads distributed over their whole length and giving 15 or 16 fixed points, which were to serve as bench marks for the determination of the deformation. A rigid steel rule in the form of a T (Fig. 6) presented, right at the points, whose spacing was the same for all cross ties, vertical rods terminated by a notch, in which was brought, while resting on the screw with square head, a gage in the form of an inclined plane, whose divi-



sions were calculated in a manner to correspond with a tenth of a millimeter. The inclination of the inclined plane had been so chosen that the interval between two divisions was at least of 2 centimeters ($\frac{77}{100}$ in.), which allowed estimating the tenth of a millimeter with exactness. The rule was fixed in an unchangeable manner to two stakes of strong dimensions, buried in the embankment about 1 m 10 (3.61 ft.), in order to eliminate the influence of the load on the supports of the rule. When the rule was in place, an observer introduced the wedge-shaped gage in the notch, while maintaining it horizontally on the head of the screw, and stopped it at the moment when it commenced to become wedged; he then made a first reading on all the points of reference, proceeding, for example, from left to right, then a second, proceeding in the reverse direction, from right to left. The readings made were recorded by the employees of the Board of Control and those of the P. L. M. Co., and the mean of them was taken, which thus gave the actual position of the cross tie.

The vehicle, which served to load the cross tie considered, was brought up, always taking care to place the same wheels at the same spot, with reference to the piece submitted to the test; it was allowed to remain during about 10 minutes, and the readings were recommenced, which caused some difficulties, since the head observer was obliged to pass under the frame of the engine and to operate stretched out to his full length. In like manner two successive readings were made, and the mean of them was taken, as has been recited above; the difference between the inscribed means gave the deformation of a cross tie under the load considered. It was necessary to count on an hour at least for the aggregate of the readings, and the necessary delays during the passage of trains made the operation require a very long time.

The preparation of the working place and the establishment of the measuring apparatus has been made by Mr. Ferry, Sub-Engineer of the P. L. M. Co., who has carried on experiments of this kind for more than 20 years, and who allies with a consummate experience a sagacity truly remarkable.

MEASURING APPARATUS FOR THE EXPERIMENTS IN THE DYNAMIC STATE.

Mr. Ferry employed for the experiments in a dynamic state a measuring apparatus which had previously served for studying the deformation of cross ties in a static state as well as in a dynamic state. It is extremely simple and strong; it presents then from this point of view an incontestable superiority over the appar-

atus employed for the same object, which would give perhaps more precise results, but whose indications require corrections always difficult to make, by reason of the greater delicateness of the measurements (apparatus of Marey). If these corrections are incomplete, the indications given conduce to results which cannot be utilized.

The measuring apparatus (see Fig. 7) was essentially composed of a stylus arranged in a stable manner at the face of a plate of smoked glass and fixed on the points of the cross tie under observation. The black smoke deposited on the glass plate,

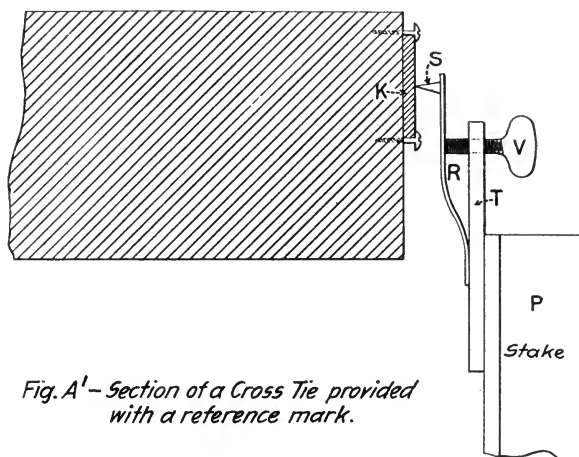

Fig. A¹ - Section of a Cross Tie provided with a reference mark.

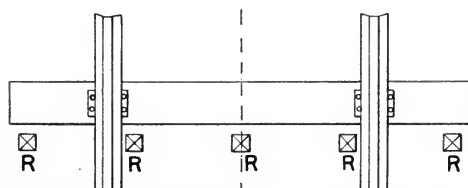

Fig. A² - Position of 5 reference marks R the length of a Cross Tie, in plan.

Fig. 7—Flexure of Ties Under Load, Shown by Reference Marks.

which was displaced at the same time and by the same amount as the points, was removed by the point of the stylus; the height of the part removed gave the value of the deflection, or of the raising of a cross tie at the points considered. The reading of this height was made by means of a magnifying glass nearly to the tenth of a millimeter.

The stylus, with flat point of tempered steel, was mounted on a very flexible spring, which could be approached to or removed

from the glass plate at will, with the aid of a thumb screw. The glass plate was fixed by screws on one of the faces of a cross tie, then smoked in the flame of a candle at the moment when it was desired to put it in service. The thumb screw passed through an iron rod and simply rested on the spring which, left free, moved back and forth on the rod fixed by means of two bolts on a stake deeply buried in the soil.

In order to make an observation, the screw is pressed against the spring until the point of the stylus comes in contact with the blackened plate. In this position a light blow is given to it, which makes it oscillate and defines a horizontal trace of 2 or 3 millimeters ($\frac{8}{100}$ to $\frac{12}{100}$ in.) length on the black smoke, a trace which forms the reference mark.

At this moment one can either place the vehicle on the cross tie, or allow trains at speed to pass over it. The height of the part of the glass plate rubbed off by the point of the stylus gives, above the reference mark, the values of the depression, and below, the uplift, of the cross tie. The latter is always inferior to the former; for the flexure is important in comparison with the movement of uplift of this piece under the influence of loads at a distance. The successive influence of each of the axles cannot be noted, but it is solely a maximum indication which is produced.

Mr. Ferry, before providing himself with the rule which we have described above for the study of the deformations in a static state, employed the registering apparatus just above, and determined with exactness the form of that deformation by placing five of these apparatus on different points of the cross tie. He was then able, by comparing the results obtained with the rule and the wedge on the one hand, and the stylus on the other, to appreciate the precision of measurements given by one or the other of these apparatus.

STOCK FOR EXPERIMENT.

The first experiments were made by an engine with three axles coupled, weighing 38.58 net tons in working order, with tender of 26.46 net tons.

These weights were thus distributed among the axles:

			Spacing.	Diam. of wheels
Engine, 1st axle.....	12.26 net tons }		6 ft. $5\frac{9}{16}$ in.	4 ft. $3\frac{3}{16}$ in.
" 2d ".....	13.37 " }			
" 3d ".....	13.37 " }		4 ft. $7\frac{1}{8}$ in.	4 ft. $3\frac{3}{16}$ in.
Tender 1st axle.....	13.34 " }		3 ft. $11\frac{1}{4}$ in.
Tender 2d axle.....	14.11 " }		3 ft. $11\frac{1}{4}$ in.

Legend:- The Curves of Deformation are represented
 in the following way:
 Experiments of May 1903 ———
 " " June " - - - - -
 " " July " ·····

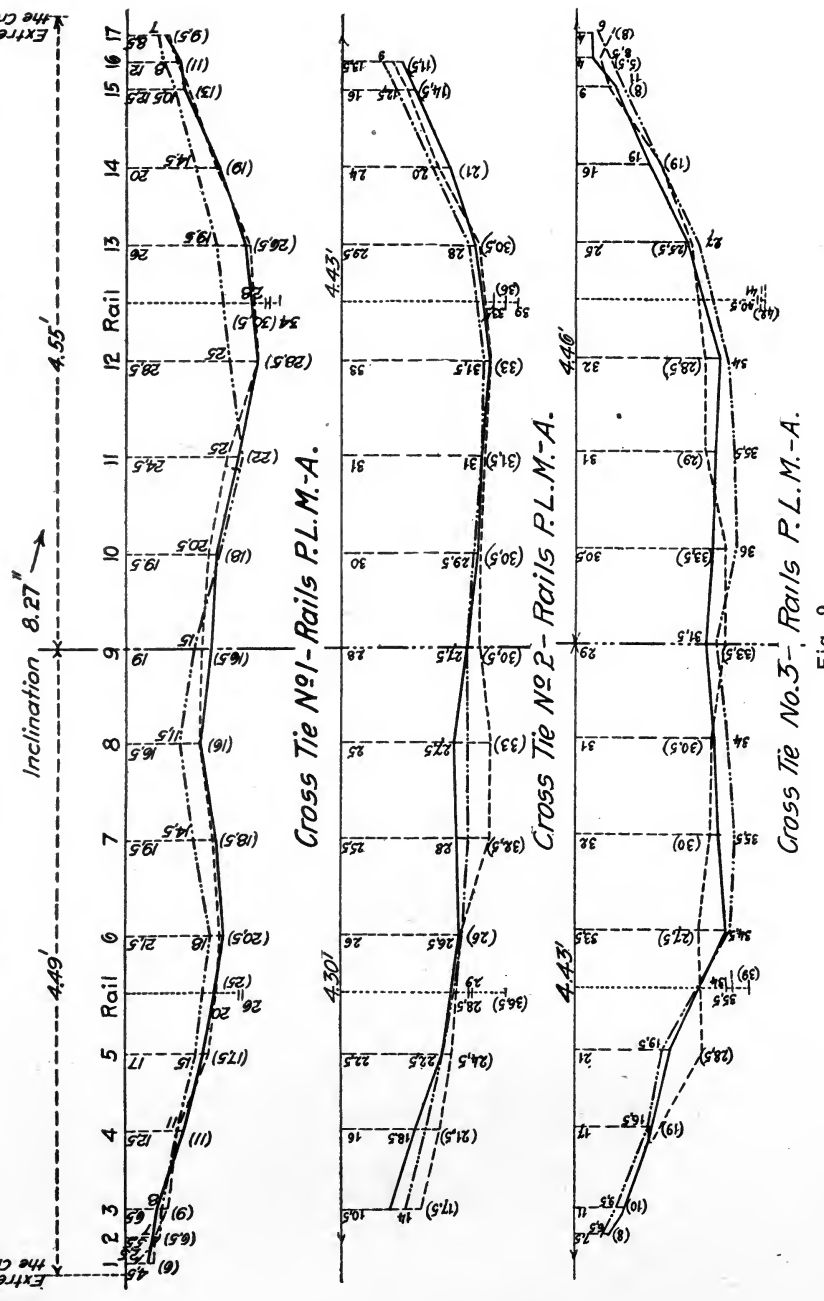

Fig. 9.

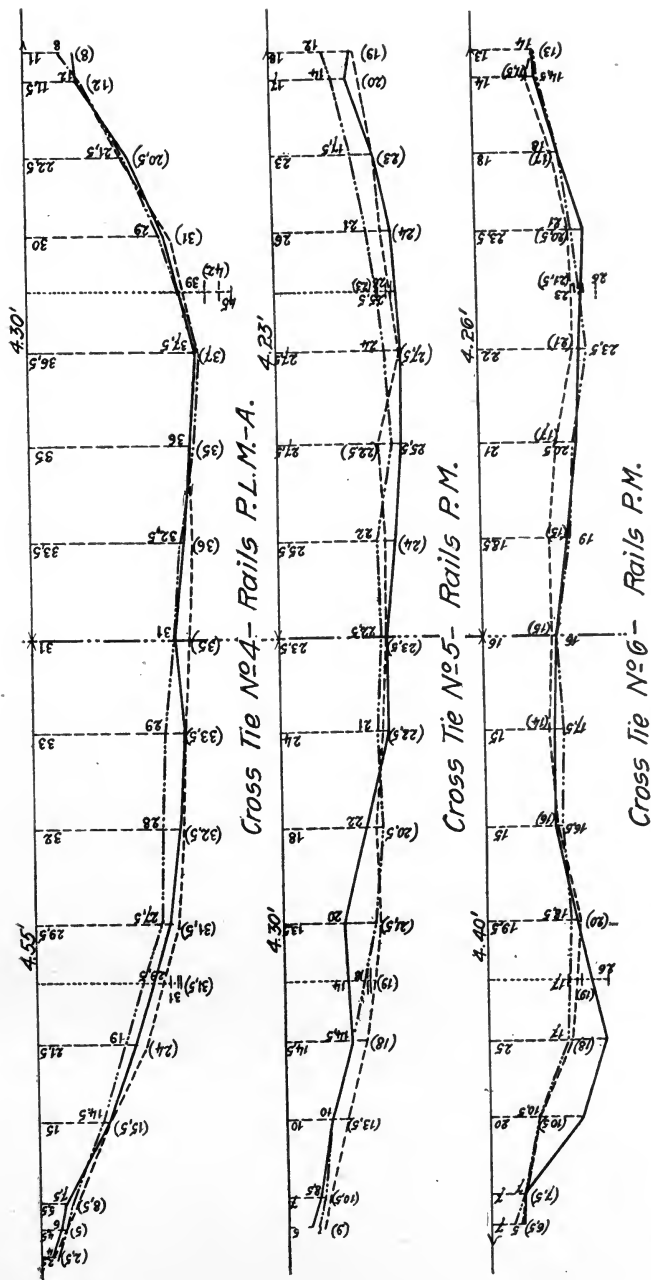

Fig. 9 (Continued).

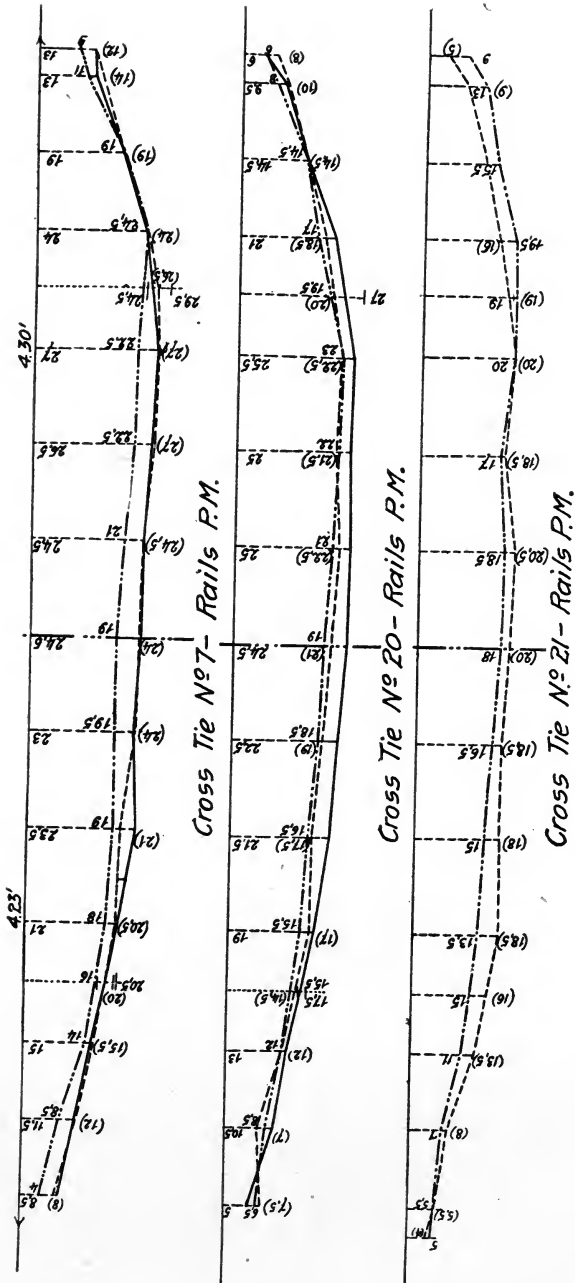

Fig. 9 (Concluded).

The locomotive and its tender were followed by a car. After having referenced the top of the tie by means of a measuring rule, the train was brought to position, in such a way that the third axle should be as near as possible to the cross tie. After leaving it in this position for about 10 minutes, the measuring rule was introduced right at the cross tie and the second reading was made. (See Fig. 8.)

EXPERIMENTS OF THE MONTH OF MAY, 1903.

The trials took place on nine wood cross ties and on 21 composite cross ties; the curves of deformation which have been observed are represented with a black line on Figs. 9 and 10. The figures are inscribed in tenths of millimeters.

It is remarked that all the curves of the wood cross ties present a well defined figure, always similar, in the form of a basin. The edges are slightly inclined up to a point near the rail, nearly at 23.62 in. from the axis of the track, and the bottom, which unites the two edges, is nearly horizontal, tending to rise towards the center and thus presenting its convexity upward. The maximum sinking of the cross tie is produced a little beyond the rail, proceeding from the extremities towards the center, and the bending, which consequently gives unequal distribution of the pressure on the ballast, is, so to speak, maximum near the rail, producing a greater sinking than at any other point.

The trials took place on four wood cross ties provided with P. L. M.-A. rails, and five others provided with P. M. rails, these rails being more rigid than the first. Fig. 11, No. 1, on which has been placed the mean of the figures inscribed on Nos. 1, 2, 3 and 4 of Fig. 9 (full black line) gives the general form of the deformation for the five cross ties considered, the errors of reading being thus more or less compensated. This general form is that pointed out above, a basin with slight swelling in the center. The mean cross tie seems to be depressed only slightly at first, a maximum .022 in., then to be inflected in the ballast proportionately to the pressure which it transmits to it. Apart from the general sinking, the piece has bends in relation to the line which joins the extremities of the elastic line defined, bends which are at 5.12 in. from the rail on the side of the long radius, where the inclined part comes to rejoin the bottom of the basin, 0.093 in., at the center 0.085 in., at 5.12 in. from the rail, on the side of the short radius, where the inclined part of the elastic line rejoins the bottom of the basin 0.101 in.

The four cross ties supporting P. M. rails furnish a mean curve of deformation similar to the first, Fig. 11, No. 2; but the mean bending and sinking which results from it are inferior to those stated above, because the rail is more rigid and because it transmits the load over a greater number of cross ties. The deformation reaches the following values at the same points:

5.12 in. from the rail on the side of the long radius.....	.043 in.
At the center051 "
5.12 in. from the rail on the side of the short radius.059 "

More rigid rails, distributing the pressure on a greater number of cross ties, diminish the flexure, and seem to distribute the load in a more uniform manner on the ballast.

Tests were also made on 21 composite cross ties; their curve of deformation is given in Nos. 1, 2 and 4 to 22 of Fig. 9 (full black line). The latter presents a very characteristic form, a horizontal straight line when the bed of the cross tie is equally resistant, and one which inflects on the side where it is the most compressible. Thus the cross ties of the even-joint, those of the following end above all, which are submitted to the shocks in consequence of the drop of vehicles from the advance one to the following one, inflect on the side of the short radius, following an inclined plane, whose declivity is on the side of the center of curvature. The curve of mean deformation, which includes the aggregate of the curves obtained (Fig. 11, No. 2) has been recorded on the curve of deformation of the wood cross ties supporting P. M. rails like the composite cross ties, in order to show a comparison; but naturally we have separated from the mean the curves of the cross ties of the even-joint, since they have nothing comparable with the wood cross ties. This mean curve is very close to a straight line, since the maximum flexure is 0.012 in. at 5.12 in. from the rail on the side of the short radius; that is to say, four times less in value than with wood cross ties. The mean sinking is about .063 in. less over its whole length, except at its extremity on the side of the short radius, than the sinking of the wood cross tie.

EXPERIMENTS IN JUNE, 1903.

These experiments took place after a relatively dry period; the ballast was somewhat dried up. The same train was employed. The work was carried on in the same manner, that is to say the third axle was brought as closely as possible to the cross tie to be studied. The trials were made on the same cross ties as before;

they were extended, however, to the wood cross tie 21 supporting P. M. rails, and to composite cross tie No. 8. The results of these trials are recorded in Nos. 1 to 9 of Fig. 9, so far as the wood cross ties are concerned, and in Fig. 10 for the composite cross ties; they are represented by full line followed by two dots.

It will be seen that this experiment worked better; the deformation has diminished, which is natural, since the ballast was dried out and the cross ties rest on a more solid and more homogeneous bed throughout its length. Between times, besides, the joints were rewedged by placing hoop-iron between the splicing and the bottom of the base; the effect is perceptible, together with the greater solidity of the bed on the side of the short radius. The flexure and the sinking have diminished considerably.

The mean curve of deformation of the wood cross ties provided with P. L. M.-A. rails, obtained as has been described above (Fig. 11, No. 3) is similar to that which was obtained in the month of May preceding, the same form of basin with a tendency to relief in the central part. The characteristic figures of this curve are the following:

Bending at 5.12 in. from the rail on the side of the long radius....	.092 in.
At the center091 "
At 5.12 in. from the rail on the side of the short radius.....	.111 "

The apparent sinking of the cross tie has sensibly diminished; its bending has remained nearly the same, which should be expected. For when the ballast is impregnated with water as in the first case, the water sustains the cross tie above the ballast. This water has to be driven out by the tie, spreading on both sides. The void is thus more considerable than when the ballast is more dry, and, in the last case, the cross tie, which is depressed in proportion to the dryness of its support, reaches it more rapidly. In a word, this ballast acts as a sponge when it is impregnated with water; it swells and heaves up the track; on the contrary, when it is dry it diminishes in volume and lowers the track.

The mean curve of deformation of the wood cross ties supporting P. M. rails (Fig. 11, No. 4) presents the same minute details, perhaps less accentuated. The characteristic figures are the following:

Bending at 5.12 in. from the rail on the side of the long radius....	.043 in.
At the center043 "
At 5.12 in. from the rail on the side of the short radius.....	.053 "

The mean curve of deformation of the composite cross ties is still more regular than in the first case (Fig. 11, No. 4); the curvature has diminished a little, and a straight line is almost

obtained, since the bending is only .008 in., that is to say, five times less than that of the wood cross ties. The mean sinking is no more than .054 in., a little less than the value attained in the month of May.

EXPERIMENTS DURING JULY.

These experiments were made during a period of rain, following one of considerable heat. About the same conditions were found as in the month of June. The ballast was not more dried out. The same experimental train was employed and the third axle was placed as near as possible to the cross tie. The experiments were made with the same cross ties. The curves of deformation, represented on Figs. 9 and 10, present the same general form. The flexure and the sinking observed in the month of June are maintained, with a slight tendency to diminish.

The mean curve of deformation of wood cross ties provided with P. L. M-A. rail, obtained as above (Fig. 11, No. 5), presents some irregularities besides, of little importance. Thus the maximum sinking on the side of the long radius should be produced at $9\frac{1}{4}$ in. from the rail; the central part should be nearly horizontal, but the maximum sinking should be maintained at 5.12 in. from the rail on the side of the short radius, and should have attained .125 in.

The characteristics of flexure are the following:

Bending at 5.12 in. from the rail (side of long radius).....	.083 in.
At the center087 "
At 5.12 in. from the rail (side of short radius).....	.094 "

The general sinking is a little more than in June.

The curve of deformation of the cross ties provided with P. M. rails (Fig. 11, No. 6) is almost precisely the same as that in June. The general sinking of the ties is about .051 in. and their flexure can be thus defined:

At 5.12 in. from the rail (side of long radius).....	.043 in.
At the center043 "
At 5.12 in. from the rail (side of short radius).....	.051 "

The composite cross ties are deformed as a whole, following almost a right line inclined according to the superelevation. Their general sinking is about .055 in. and the greatest flexure about .011 in., four times less than that of the wood cross ties under the same conditions.

SUMMARY AND CONCLUSION.

The experiments which we have just related can be summarized in the following table:

(Figures in fractions of an inch.)

Type of tie used.	—Mean sinking—			—Mean flexure—		
	May.	June.	July.	May.	June.	July.
Wood, with P. L. M. = A rails...	.077	.076	.084	.090	.097	.087
Wood, with P. M. rails.....	.066	.060	.066	.047	.043	.043
Composite, with P. M. rails.....	.053	.059	.059	.008	.008	.008

The table shows:

(a) That the mean sinking of the wood cross tie provided with P. M. rails is nearly the same as that of the composite cross tie, although slightly superior.

(b) That its flexure is nearly six times greater.

But it is not necessary to depend upon these results; if it is interesting to know the mean sinking and the flexure of cross ties, it is still more so to know the value of that sinking and of that flexure right at the rail. It is given in the table below:

Type of tie.	Sinking and flexure right at rail.			Mean flexure.
	—Month of—			
	May.	June.	July.	
Wood with P.M. rails.....	.087 in.	.083 in.	.081 in.	.084 in.
Composite with P.M. rails.....	.073 "	.046 "	.062 "	.065 "

Thus the movement of a track is reduced by 25 per cent. by the employment of the composite cross tie; and this reduction would be still more considerable with rails less worn and a ballast less spongy. Another interesting fact brought out by these experiments is that the wood tie, which is regarded as bearing over its whole length, descends in the track by a greater quantity than the composite tie, which has only a limited bed, 4.59 ft.

We have sought the cause of this anomaly, which did not, at first view, appear explicable. The composite tie exercises a uniform pressure on the ballast at each of its extremities over a length of 27.56 in.; the cube of ballast elastically displaced by this pressure is proportional to the hatched surface of Fig. 11, No. 6. (Experiments of July, 1903). On the side of the short radius this surface is .01942 sq. in., and, on the side of the long radius, is .01307 sq. in.; these two numbers, 1,942 and 1,307, are respectively proportional to the cube of the ballast displaced. Now this cube is itself proportional to the pressure received by the ballast within the limits of elasticity, which ought not to be reached in the particular case; it follows, then, that the wood cross tie, which exercises on its own account an equal pressure, being submitted to the same loading, ought to displace a volume of ballast equal to

that which is compressed by the blocks of the composite cross tie, and that its real length of support is determined by this condition. Thus, in the particular case, the length of support of the wood cross tie ought to be the height of the mixti-lineal trapezium comprised between the original axis of the cross tie and its curve of deformation, the surface of which trapezium should be equal to that of the hatchèd part. It is thus found, by neglecting the extremities of the cross tie which, being removed from the center of pressure, should react feebly, that the surface of support of the wood cross tie, which is indeterminate by reason of the irregularity of the tamping, does not exceed the length of the blocks of the composite cross tie, that is to say that it extends about 13.78 in. on both sides of the axis of the rail. The central part of the cross tie is, therefore, not utilized to distribute the pressure, and serves only as a tie bar to unite the support of the rail. It is even probable that this central bed not only does not press on the ballast, but even that it is uplifted by a kind of sub-pressure, due to the elastic compression of the ballast right at the points of support. The ballast can be likened to an elastic matter, peat for example, which is depressed at the point where the pressure is exercised, only to flow back farther away.

The German engineers who have studied this question with much care, Messrs. Weber, Winckler and Zimmermann, have admitted, without ever having demonstrated it, that the pressure, P , of the ballast per unit of surface of the cross tie which it supports is, at each point, in direct ratio with the sinking, Y , of the latter. They thus place $P = C Y$, an expression in which C is a coefficient depending upon the qualities of the ballast, invariable for the rest, and whose numerical value is determined by experience.

For $Y = 1$ cm, we have $P = C$. Consequently, it is the pressure in kilograms on the unit of surface (square centimeters) necessary to produce a sinking of 1 cm, and its value introduced into the calculation takes the name of coefficient of ballast.

The hypothesis of the sinking proportional to the pressure can only be admitted within the limits of elastic deformations. The statement of the proportionality of the sinking and of the pressure in certain limits, the determination of the latter as well as the numerical determination of the coefficient of ballast, have given occasion, on the part of German engineers, for researches whose results are the following:

- (a) The results of experiments agree quite closely with the

supposition that the pressure on the unit of surface is in direct proportion with the measure of the sinking.

(b) With a subsoil supposed to be good, the magnitude of the coefficient of ballast has been found, for gravel ballast (without metalled bed) $C = 3$; for gravel ballast (with metalled bed) $C = 8$; for ballast of small stones and scoriæ, $C = 5$.

(c) Loads, such as are found in regular operation, produced, almost exclusively, elastic flexures. The permanent deflections, which have been observed, probably have the effect produced by repetition of dynamic actions as their cause.

(d) The sinking observed under a load in motion, at speeds varying from 40 to 60 kilometers (24.85 to 37.28 miles) per hour, were not much greater than the sinking observed under the same load in a state of repose.

All this very ingenious theory errs in the premises, because its authors have admitted, as an axiom, that a loaded cross tie should have a bearing over its whole length. The experiment made with composite cross ties, whose bed on the ballast is well defined, and which bends little, allows us to pronounce on this point without possible controversy. The pressure which the rail transmits to the ballast by the intermediary of the cross tie is exercised only on a very limited zone of support, a zone which does not exceed 13.78 in. on both sides of the point of application of the load. The German engineers believed that this zone of influence of loads was of tolerably large extent, for they have fixed the length of cross ties at 8 ft. 10.3 in. and recommended the employment of pieces as long as possible. It is the conclusion at which Mr. Ast, notably, has arrived in the fifth section of the International Congress of Railways, in a memorandum on track:

"A better means for distributing the given load on the greatest possible number of cross ties, and, consequently, on the greatest possible surface of ballast, consists in the reduction of the spacing of the cross ties and in increasing their surface of support. These two measures have, however, their limits; the first because it is necessary to preserve the possibility of tamping, the second because, on the one hand, the width of ties cannot be too great, if one wishes to be able to tamp well underneath, and because, on the other hand, the length which can be conveniently given to them depends on the gage. The prolongation of ties can only bear, in fact, on the parts situated at the exterior of the two lines of rails. When this prolongation surpasses a certain limit, the loads on the rails, which act on the interior of the gage, provoke a super-elevation of their

Experiments of May 1903

Legend:- The Curves of Deformation are represented in the following way.

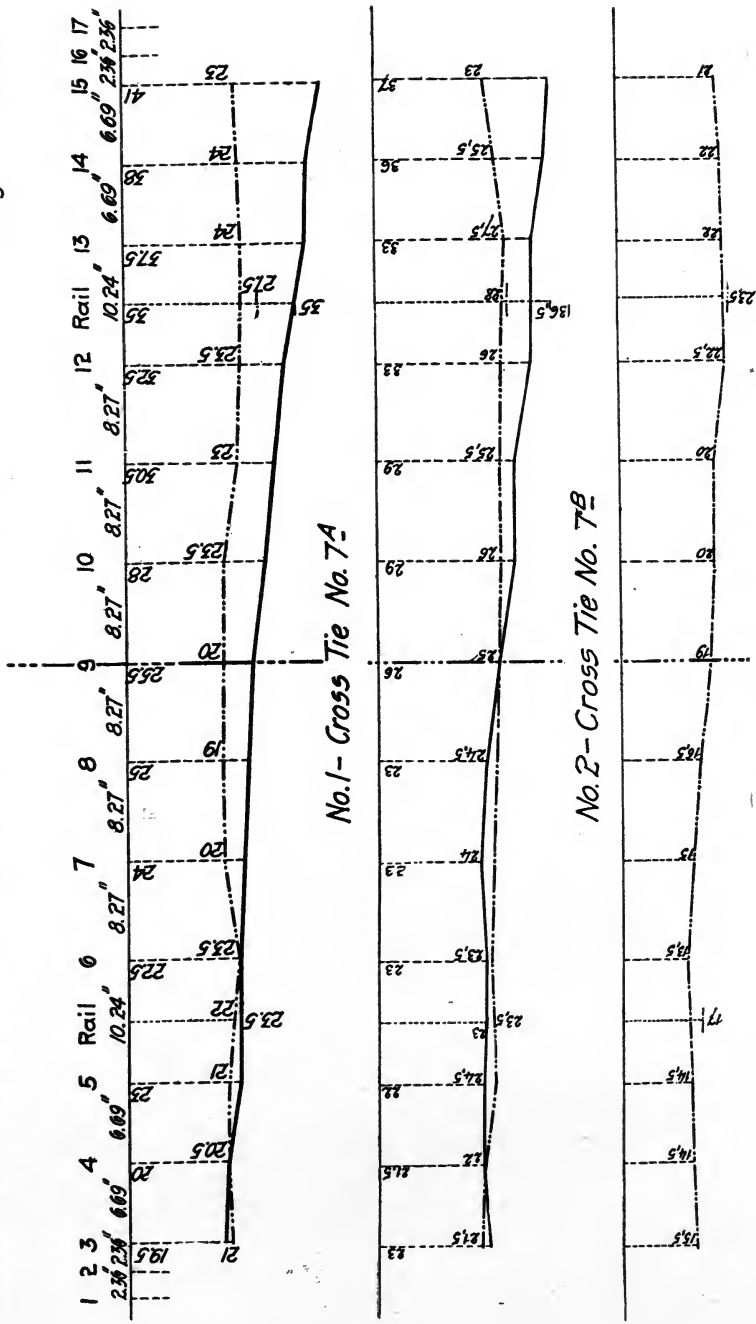
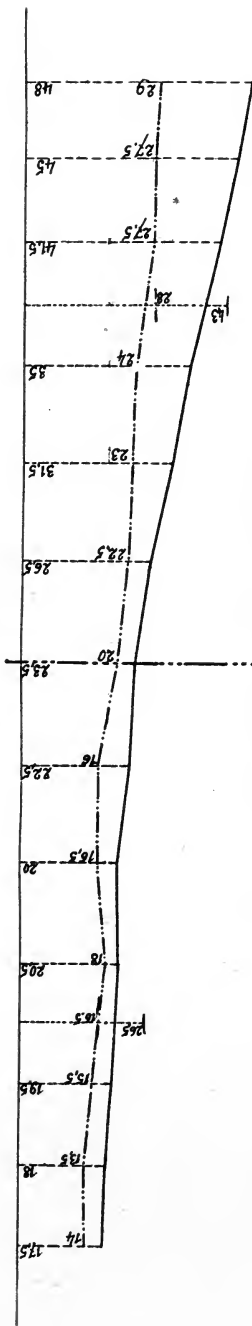
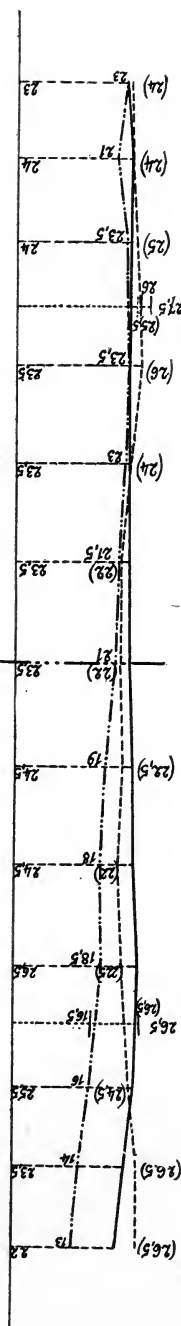

Fig. 10

No. 6 - Cross Tie No. 10 A



No. 7 Cross Tie No. 10 B



No. 8 - Cross Tie No. 11.

Fig. 10 (Concluded).

Legend: The Curves of Deformation of Wood Cross Ties are represented by a full line
 " " " Composite " " " " dotted

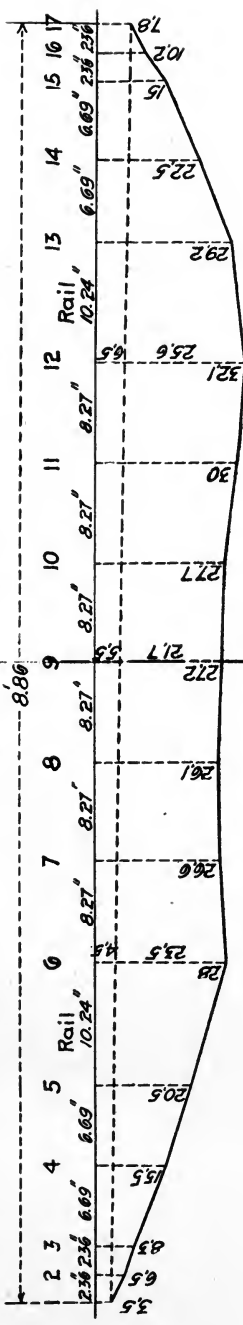

Experiments of 4th. and 5th. of May 1903

No. 1 - Mean Curve of Wood Cross Ties Nos. 1, 2, 3, 4. Rails P.L.M.-A.

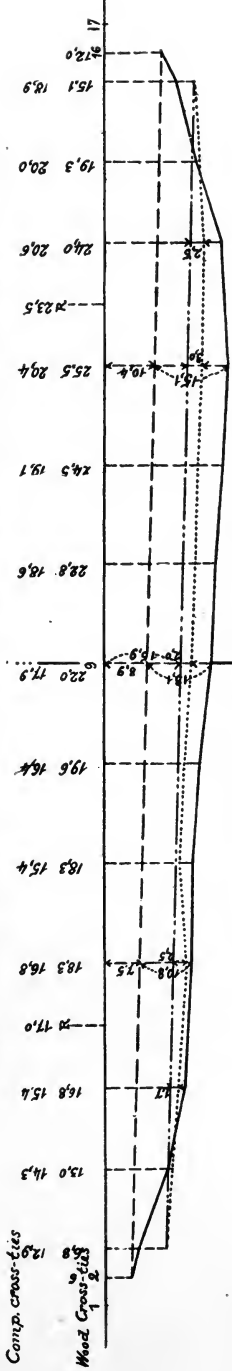

Experiments of 4th. and 5th. of May 1903

No. 2 - Mean Curve of Wood Cross Ties Nos. 5, 6, 7, 20. Rails P.M.

Fig 11.

extremities, and the parts of that length in excess no longer have a bearing."

This last fact has been verified; Mr. Ferry, Sub-Engineer of the P. L. M. Co., has obtained curves of deformation of long cross ties 8 ft. 6.4 in. to 8 ft. 10.3 in. placed in resistant ballast (broken stone), on which the extremities are seen raised up above the axis of the part not loaded. The experiments performed show also, although in a less clear manner, this fact: the more wet the ballast is, the more gentle is the slope of the extremities, for the pressure is transmitted over a greater surface; on the contrary, when the ballast is dry, the ends of the cross tie have a tendency to raise up.

Therefore it is impossible to diminish the sinking of ties by increasing their length; moreover, independent of its uselessness, this prolongation produces a grave disadvantage, for it increases the bending. It is not by this means that we should seek to reduce the deformation of the track, but by widening the cross tie, by concentrating the material about the points of support, and above all, by augmenting its moment of inertia.

The composite ties have an effective length of 8 ft. 2.4 in., but the useful length, that is to say that comprised between the two extremities of the blocks, is no more than 7 ft. 2.64 in.; it is at once seen in Fig. 12, Nos. 2, 4, 6, that, reduced to 7 ft. 2.64 in., the cross tie would still have a less flexure. This last consideration, joined with the examination of the curves of deformation of the ties of 8 ft. 6.36 in., has led to research as to what ought to be the length of a tie and of its tamped bed in order to reduce the flexure in the greatest measure possible. The long ties affect the deformation pointed out above with concavity directed upward; the short cross ties ought, on the contrary, to be deformed according to a convex curve; between the two there ought then to be such a length that the deformed curve approaches a right line. We propose to make that research which appears to us to present a great practical interest.

But before entering upon this new order of ideas, it would have been interesting to present the theory of the cross tie which results from these experiments, and which is very far removed from that admitted by Winckler; it would have been established that theory was in accord with experiment, that is to say, that the curve found experimentally was quite like that of a beam placed on an elastic support, but less elastic than it, loaded at two points with loads exercising their influence on a predetermined

zone of support. It would, then, be a question of determining, with that hypothesis, the reactions of this support, and of demonstrating that, in the central part, the cross tie was found to be submitted to a counter pressure. Unfortunately, time was wanting for examining this problem of elasticity, which is long and difficult; the elements acquired will doubtless permit of giving the solution after a brief delay.

In the meantime, we desired to determine the coefficient of ballast in the experiments carried on, this coefficient being defined, as has been stated above. The axle loading being 26,455 lbs., the load on the rail, that is to say the load on the tie, was about 13,228 lbs. (for it is admitted that on a track with rigid rails the maximum load on a given cross tie is about 50 per cent. of the load on the axle); the 13,228 lbs. ought to be distributed between the two composite blocks proportionately to their sinking. The block on the side of the short radius will thus support 7,945 lbs., and that on the side of the long radius 5,282 lbs. The mean sinking of the first block being .052 in. and that of the second .048 in. (Experiments of July 30, 1903, Fig. 11, No. 6) the pressure of the ballast per unit of surface will be 29.15 lbs. per sq. in. on the side of the short radius, and 19.34 lbs. per sq. in. on the side of the long radius. The coefficient of ballast, that is to say, the pressure per unit of surface capable of producing a sinking of $\frac{28}{64}$ in. in the ballast and the subsoil considered would be 160.14 lbs. per sq. in., that is to say three times higher than that adopted by the German engineers. The ballast and subsoil considered were, in fact, of mediocre quality. It is then supposable with some reason that with a good ballast and a very solid roadbed the coefficient of ballast will be at least 284.5 lbs. per sq. in. The precise experiments which we will next undertake will permit of elucidating this point more completely.

CHAPTER III.

LENGTH TO GIVE TIES AND TAMPED BED.

After proving that the most advisable length for a tie for diminishing its flexure ought to be in the neighborhood of 7 ft. 2.64 in. I desired to determine the latter experimentally with wood ties of different lengths, tamped unequally, and placed on a level and on straight line, in order to avoid all chance of error.

Mr. Ferry, Sub-Engineer of the P. L. M. Co., wished expressly to aid me with his counsels, and to build an experimental side track. This track, placed at the extremity of the cul-de-sac of the track for unloading animals at the station of Bourg, P. V., was isolated from the switching of that station, so that we could easily proceed with all the trials without being obliged to abandon them and then resume them, which causes the loss of much time and interrupts their course.

The ties on trial, wood, steel and composite, were always placed at the same point, about 6.56 ft. from the neighboring ties; the rail was raised up on it $\frac{25}{64}$ in. above them; thus the axle load, 13.22 net tons, rested entirely on the experimental piece. In order to avoid raising of the track at the extremity of the cul-de-sac, the extremity of the rails was loaded and held in place. A tent was set over the working place to completely shelter the track and withdraw it from atmospheric influences; in this manner, the ballast, formed of fine gravel, and the subsoil, were always found in the same hygrometric conditions. A tie was placed at the pre-determined site, and at the aforesaid height, with reference to the neighboring cross ties; for there were buried in the roadbed in excavation, on both sides of the track, two strong stakes 4.92 ft. deep, and between them a rigid string was extended, in order to determine the position of the axis of the piece and the height of the rail.

The parts marking the surface of the tie in a free state were measured by means of the rule described, as has been explained in the preceding tests. Two readings were taken by means of the wedge gage provided with a runner, in order to be able to esti-

mate the hundredths of a millimeter. The wood ties were provided, as before, with screws with square heads, invariably fixing the points of measurement; but in order to assure the horizontality of the wedge, there was placed in front of the first screws other similar screws provided with a notch for guiding it.

The vehicle, loaded with care with pieces of rails, weighing 26.46 net tons, was mounted on two axles; when the first reading was finished, it was brought close to the cross tie, at a point of the rail determined by the position of the wooden wedges. It was allowed to stand for an hour, and two readings were made on each point, as in the other tests. Each reading was controlled with care and checked by other experimenters when the difference attained two hundredths of a millimeter. The mean of the figures was taken, which approached consequently nearly to one hundredth of a millimeter. The vehicle was removed, the beam recovered, and the new position of its axis was ascertained by two new readings. The difference between the figures of the original position without load and of the position with load, gave the total sinking; the difference between the latter situation and the new position of the piece without load, determined the elastic sinking. The permanent sinking resulted from the difference between these figures. In Nos. 1 to 12 of Fig. 12, which displays these experiments, the full lines represent the position of the original axis and of the deformed axis; the dotted line, the axis after recovery of the beam.

The experiments were made with wood ties of different lengths with variable tamped beds, and with the composite tie and the steel tie of the state.

Wood tie 8 ft. 6.36 in. by 8.66 in. (Nos. 1 and 2, Fig. 12.)—We commenced with an oak cross tie well squared, 8.66 in. wide, 5.51 in. thick and 8 ft. 6.36 in. long. The tamping extended over its whole length. The beam was deformed under the load according to the curves in Nos. 1 and 2 of Fig. 12. Their form is convex, raised towards the center, with a tendency to uplift at the extremities, the pressure being less strong at those points. The sinking is more pronounced on the left side, .16 in. by .18 in., than on the right side, .154 in. by .173 in., by reason of the greater solidity of the subgrade. At the center it is only .10 in. and .12 in. The elastic upraising is greater in the first test than in the second, without doubt because the tamping had been more compact; it attains, in fact, .091 in. in the first case and .06 in. second. The greatest compression is found on the exterior side of the rail (first test .185 in., second test .18 in.), which is explained by the reac-

tion of the ballast, which rights the cross tie and inclines it towards the extremities.

Tie 8 ft. 6.36 in. by 8.66 in., tamped at the end at 15.75 in. each side of the rail. (No. 3, Fig. 12.)—The same tie, tamped at its extremities and at 15.75 in. on each side in the interior, served for this test. The tamping was limited by two angles fixed to the bottom of the tie at the extreme points of the tamping. The form attained is that of the basin observed at St. Etienne-du-Bois; the bottom is slightly raised in comparison with the left side; the extremity of the right, resting on a more solid foundation, is raised more. The compression is maximum in the interior of the track; the sinking attains .185 in. to the left and .18 in. to the right. The elastic uplift has taken place according to a slightly concave curve, like that which is generally observed at the working places of cross tie renewals. It is sensibly equal to that stated above, about .063 in., the mean permanent sinking being .106 in.

Tie 7 ft. 6.96 in. long, tamped over 15.75 in. on each side of the rail. (No. 4, Fig. 12.)—The same tie reduced to 7 ft. 6.96 in. and tamped over 15.75 in. on each side of the rail was the object of a test. The tamping was limited as above by angles. The curve took the form of a basin more flattened than the preceding, with raising in the central part, the pressure tending to be distributed equally over the ballast. The total sinking is less in consequence of this fact; it scarcely reaches .150 in. while it exceeds .18 in. in the preceding case. The elastic uplift is consequently a little less. The maximum pressure is exercised in the interior and near the rail.

Tie 7 ft. 6.96 in. long, with tamped bed 15.75 in. and 21.65 in. (No. 5, Fig. 12.)—This tie, 7 ft. 6.96 in. long, was unsymmetrically tamped 15.75 in. at the extremities and 21.65 in. in the interior. The total sinking is not greater than in the preceding case; the pressure is distributed; the center is raised up, being little more than with the symmetrical tamping, which depends on the fact that it is naturally more supported. The elastic uplift is made as above; the beam is righted so to speak parallel with itself.

Wood ties 7 ft. 3 in. long, with tamping 13.78 in. on each side of the rail. (No. 6, Fig. 12.)—The same tie, reduced to 7 ft. 3 in. long, was tested with two different repetitions with a symmetrical tamping 13.78 in. long on each side of the rail. The curvature of the elastic line diminishes (No. 6, Fig. 12); the beam is lowered, so to speak, parallel with itself. The pressure is equally distributed over the ballast. The total sinking seems greater,

which holds with tamping which has been more or less condensed; but the elastic uplift, which is only to be considered, is nearly the same, to some tenths of a millimeter.

Wood tie 7 ft. 0.6 in., with unsymmetrical tamping. (No. 9, Fig. 12.)—The unsymmetrical tamping of this same tie, which is 7 ft. 0.6 in. long, because it was effected over 12.6 in. at its extremities and over 14.96 in. towards the interior, raises the preceding curve toward the center, a curve which is convex at the middle and inclined towards the extremities.

The pressure is exercised more towards the exterior, for the reason that the beam is sustained on the side of its center; it is distributed, however, better than in the first cases examined; the total sinking is always nearly the same as the elastic uplift. The latter preserves the same value approached after a second test. The beam returns parallel with itself.

Wood tie 6 ft. 11.04 in., with unsymmetrical tamping. (No. 8, Fig. 12.)—This tie was 6 ft. 11.04 in. long, with an unsymmetrical tamped bed of 11.81 in. at the extremities, and of 15.75 in. towards the center. It takes a convex form under the load, as in the preceding test. The maximum sinking, very pronounced towards the extremities, is more important because the latter have been brought more closely to the point of application of the pressure. The elastic uplift is the same, and is made nearly parallel to the axis of the deformed beam. After three successive tests, the second after two hours, the third after four hours, the lowering has scarcely increased; the beam is always deformed parallel with itself and the elastic uplift remained what it was after the first test.

The composite tie (No. 10, Fig. 12) behaved as in all earlier experiments; it was lowered nearly parallel with itself without apparent deformation. It reascended the same. The total sinking is nearly the same as for the wood ties; the elastic uplift is also the same. The beam is righted according to a plane slightly inclined on the side where the earth was the more solid.

The metallic tie of the state system (Nos. 11 and 12, Fig. 12) was tested with two tamped beds, the first over its entire length, the second over its breach, and 15.75 in. long in the interior of the track.

In the first case the deformation has occurred in a very irregular fashion, following a convex form in the center with the ordinary sinking; the beam is uplifted according to a plane inclined to the left. It seems, at first sight, to have no very regular resistance in all its sections, and to be bound to be deformed quite rapidly.

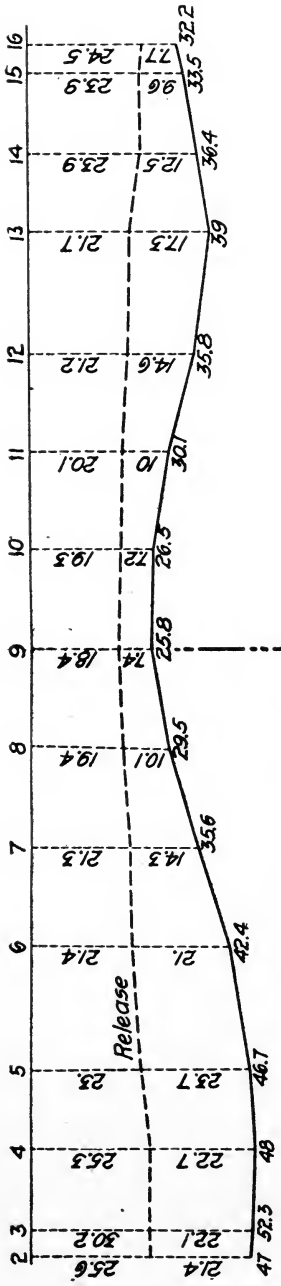

No. 1 - Wood Cross Tie of 8.53 ft. x 8.66 in. Tamped for its entire length.

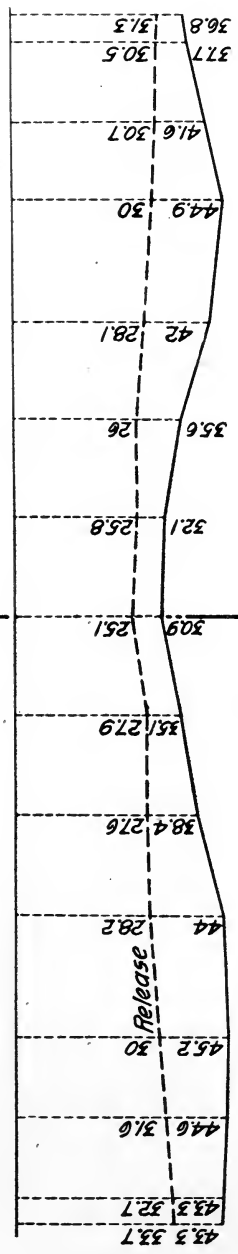

No. 2 - Wood Cross Tie of 8.53 ft. x 8.66 in Tamped for its entire length.

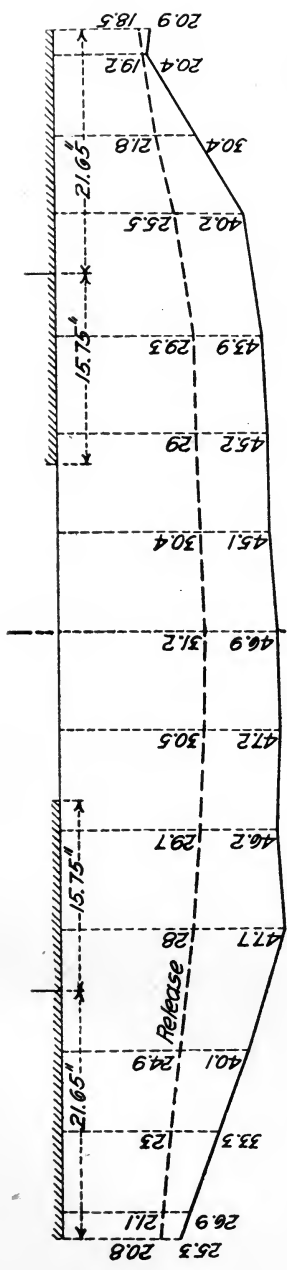

No. 3 - Wood Cross Tie of 8.53 ft. x 8.66 in. Tamped at end and for 15.75" on each side. in the Interior.

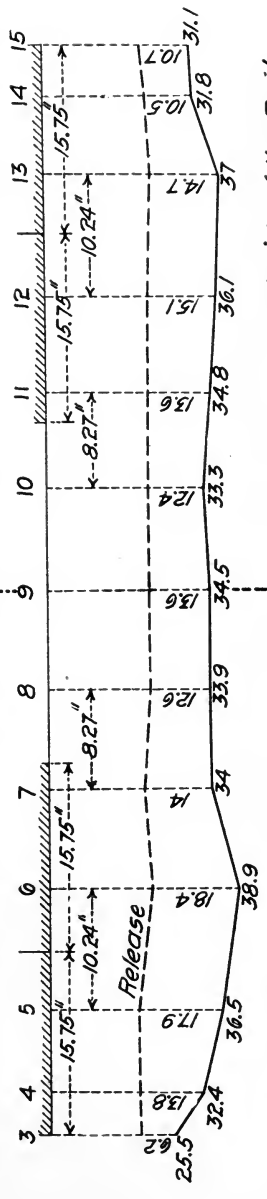

No. 4 - Wood Cross Tie of 7.58 ft. length Tamped for 15.75 in. on each side of the Rail.

Fig. 12 (Continued).

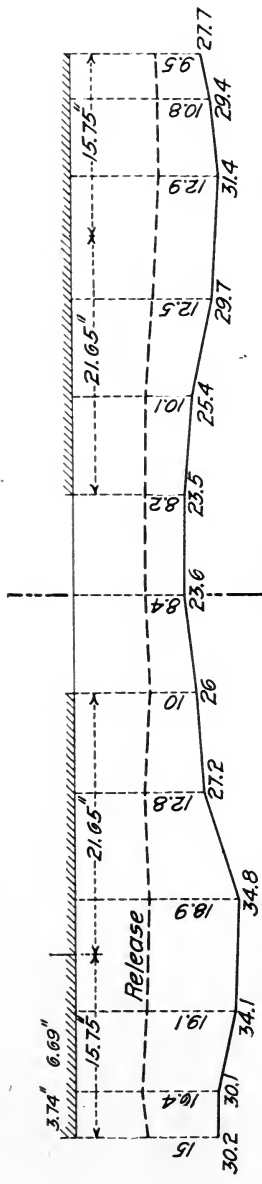

No. 5- Wood Cross Tie 7.58 ft. long Tamped for 15.75 in. and 21.05 in.

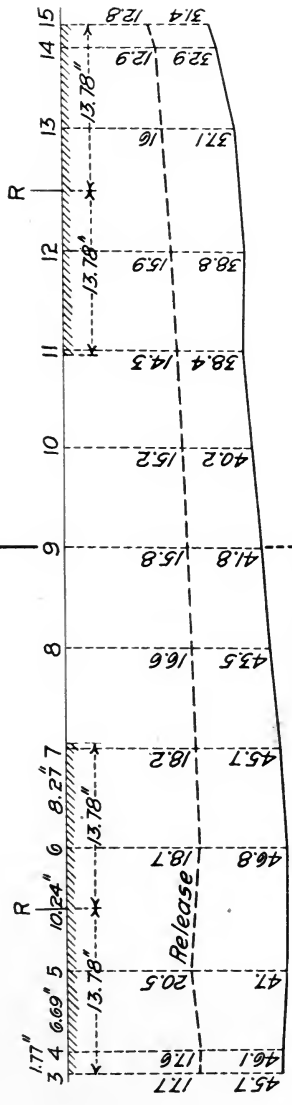

No. 6- Wood Cross Tie 7.25 ft. long Tamped for 13.78 in. on each side of the Rail.

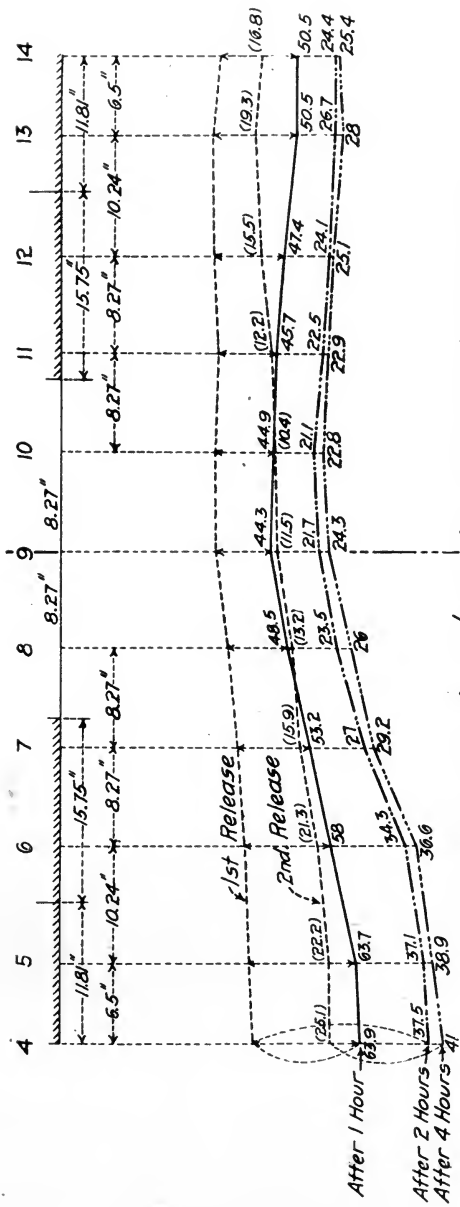

No. 8 - Wood Cross Tie 6.92' long with Unsymmetrical Tamping.

Fig. 12 (Continued).

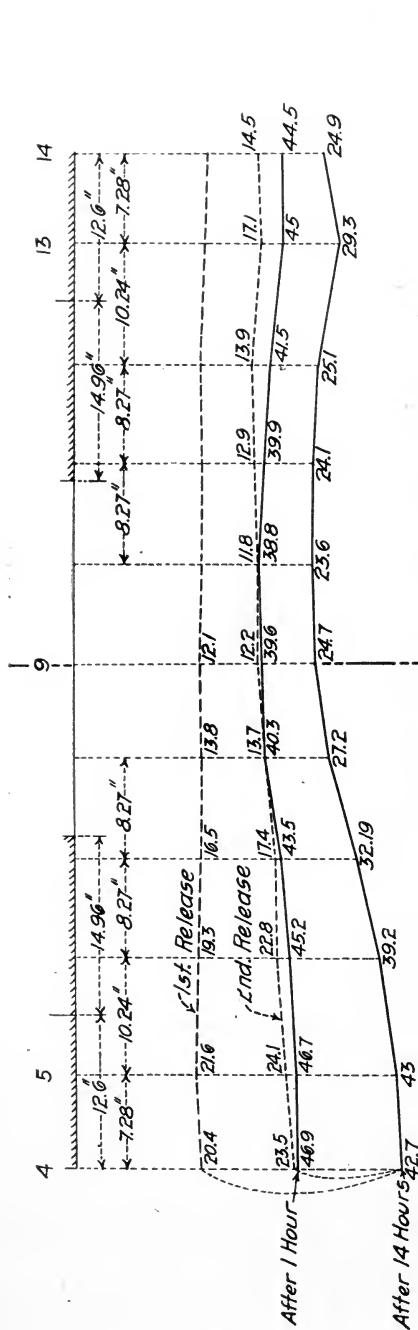

No. 9 - Wood Cross Tie 7.05 long with Unsymmetrical Tamping.

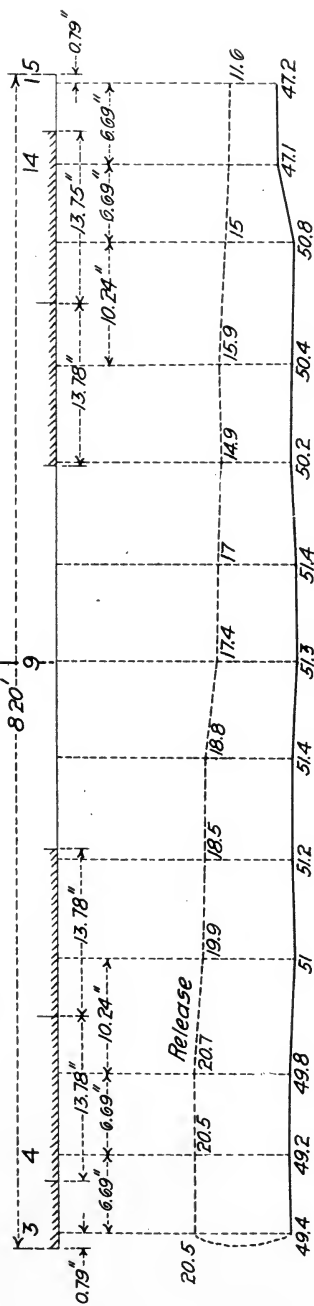

No. 10 - Composite Cross Tie.

Fig. 12 (Continued).

In the second case, the curve is more regular and is concave towards the center. The beam is righted according to the profile of a catenary, which ought to give it in time a permanent deformation and produce a diminution of the track gage.

In all the experiments which have just been related, the relative sinking of the ties with each other has not been sought for, since that question was solved on the main track from Bourg to Saint-Amour, and since the necessity for a tamped bed, executed in a more or less firm manner, in one test or the other, and, as a consequence, irregularly settled, render all comparison illusory.

But the following points should be retained from the study which has been made:

(a) The long ties, 8 ft. 6.36 in. to 7 ft. 6.6 in., take, under the load, the form of a basin, with the bottom slightly raised in the center.

(b) The short ties, 7 ft. 0.6 in. to 6.5 ft., are deformed according to a curve, convex or otherwise, and inclined toward the extremity.

(c) The ties between 7 ft. 0.6 in. and 7 ft. 2.64 in. are lowered parallel with themselves without sensible curvature.

(d) The unsymmetrical tamping raises the curve towards the center; a very feeble lack of symmetry reacts very clearly in this direction.

(e) It is possible, then, by increasing the rigidity of a cross tie, notably by concentrating the material about the supports, to reduce its sinking to the quantity which is intended as a limit, and its flexure in such measure as one would wish.

(f) The permanent sinking of the ballast is variable according to the case, but the elastic sinking, the only one there is reason to consider, is, so to speak, constant, whatever be the length and type of the cross tie adopted. The deformation is slowly produced and augments with time.

DYNAMIC EXPERIMENTS.

The results obtained under moving loads, at the passage of several trains traveling with different speeds, have always been the same, comparatively, as those obtained in the static state. They are always less, from 10 to 20 per cent., than the latter, and the difference observed between the flexure of the wood ties and of the composite ties supporting the same rails is maintained, the latter being less deformed, and sinking less than the former. The reference marks were at first placed at 5.12 in. on the interior of the two

rails, points where the maximum deformation in the static state is produced, then on five points equally distributed over the length of the pieces. The figures have always been found less than those of the static state (the mean .05 in. for ties of wood, .035 in. for composite ties); the composite tie descended parallel with itself, while the wood tie is deformed according to the curves described cases. The deformation of the material is made slowly, and as above.

All the experiments which we have made, as well as those which have been previously realized by Mr. Ferry, lead to the same conclusion; dynamic actions produce less effect than static actions; in order to obtain the maximum deformation, it is then sufficient to examine what occurs in the static state.

The apparatus for measurement, which is very simple, and disposed in such a manner as not to be influenced in the course of the trial, cannot be considered faulty. The rod which sustains the spring is buried to 4.92 ft. in the soil; it should be able to rise up vigorously under the load, which would increase the bending figures, but it cannot descend under that influence. As to the spring, it will not grip against the glass plate, but it will slide against it. Besides, Mr. Ferry has shown that the figures of deformation were the same in the static state, whether they be observed by means of the rule or by means of the spring register. The results obtained under a moving load ought, then, to be considered as exact.

It is necessary, then, that the dynamic actions be exercised with less intensity than the static actions. There is, we believe, a law which ought to be nearly general, except in certain particular much more slowly as the latter is more rigid, and as the mechanical actions take place in a short time. A spring registers slowly the forces to which it is submitted; at the same time, preserved from their effect, it is distended no less slowly, and retakes its primitive form in a time of definite duration. One can walk without leaving an imprint on a moving soil of weak consistency, when walking rapidly; the deformation has not had time to be produced. If, on the contrary, one stood still on the same soil, the latter would be deformed more or less rapidly, according to its degree of resistance.

All the known facts confirm this law of deformation, which can be considered as general. Without doubt, it is admitted that in metallic work, dynamic actions increase static actions by 70 per cent.; but that does not weaken in any way the law which we have derived from these experiments.

The tie on which the flexure has been studied does not take

the proper deformation which it should have under the action of loads, but it undergoes that of the ballast, which serves for its support, and of the bed of the ballast. It results that its deformation is limited by that of the material which sustains it. This material acts on the tie after the manner of a powerful spring, which slowly registers the forces which it receives, and which does not attain to registering them completely when they arrive in too short a time. In particular, the shocks which are the consequence of dynamic actions, and which are only susceptible of increasing the flexures in the static state, cannot produce this effect, because they act in too short a time for influencing the spring.

It is not the same as a piece of metallic work, which, not being sustained, obeys all the vibrations it receives, and which are so much the more intense as they are due to a more violent and shorter shock. Such is the chord of an instrument, which, taut, enters into vibration under an instantaneous influence, for example, the sound rendered by a neighboring instrument. Shocks have thus an important action on a metallic floor, which registers them by reason of its situation and their instantaneousness; but they have not any on a piece sustained by an elastic material but reacting by its mass after the fashion of a spring. It is possible that the materials of the track, the rails, for example, do not obey this last law, but the experiments made up to this time permit of no conclusion either in one direction or the other.

Apart from the transverse movement, which we have just been studying, the track is submitted to a lateral movement, which is explained as a sliding movement, and often causes derailments. Weber has determined the maximum values of the sliding movement of the track which are produced in the course of normal traffic. His tests have demonstrated that in alinement it produces displacement which may reach $\frac{1}{8}$ in. for the base of the rail, and .28 in. for the head.

Engesser has proved that it would suffice for main tracks, to take 0.15 to 0.25 G (G load on wheel) as the ordinary value of the horizontal force.

But if the greatest vertical pressures on the track are produced by the overloaded axles, the greatest horizontal pressures are due to the unloaded axles. The latter have their greatest effect when the ballast is the most unsettled, that is to say, when it has just been changed or renewed.

It was then placed under the most unfavorable conditions; the experimental ties were arranged as follows: Wood ties and steel

ties in a switching track at the Bourg station. They were isolated from the neighboring ties, either by superelevating them and removing the plates from the neighboring pieces, or again by withdrawing the latter from the track; in this manner it was certain that the cross tie under experiment alone sustained the weights which were placed on it. Besides, the shoulder plate of the cross tie under experiment was replaced by an ordinary flat plate, and the screw spikes were withdrawn so that the cross tie could slide under the rail, but in order to diminish the friction, the surfaces in contact were greased.

This done, the tie was pushed, being thus rendered independent, and without load, by means of the Collet déclinmètre, installed, on the one hand, against the extremity of the piece, and on the other hand against a very solid wall. Then the same tie was loaded by means of an axle of 6.61 net tons, and the experiment pushed in the two cases up to the moment when a displacement of .8 in. was obtained, at which the track can be considered as out of service.

The results of these experiments are given in the table below:

	—For a displacement of .8-in.—	
	—Without load.—	With load.
Composite tie, in the free state.....	From 4,189 to 5,291 lbs.	15,212 lbs.
Wood tie, in the free state.....	220 lbs.	11,684 "
Steel tie, in the free state.....	1,102 "	7,496 "

The composite tie offers a resistance 24 times greater than that of the wood tie when it is not loaded, that is to say, when this resistance presents its weakest value. When it is loaded with an axle of six metric tons, its resistance to sliding is still greater by nearly 3,307 lbs. than that of the wood tie. This is not true of the steel tie; the latter, at first more resistant than the wood tie, not carrying any load, becomes less under the load, which appears to arise from the less friction of the ballast against the metallic body.

If only the two ties, respectively the wood and the composite one, are considered, it is observed that their resistance to sliding being respectively about 220 lbs. and 4,409 lbs. without load, there remains for the resistance under the load of 6.61 net tons, 11,464 lbs. for the first and 10,802 lbs. for the second. The friction which operates against the sliding is thus proportional to the weights and not to the frictional surface or the substances having the same adherence with the ballast. Mr. Ferry has found that for wood ties this resistance varies from 50 to 80 per cent. of the overloading, 50 per cent. when the pieces are smooth, freshly creosoted, 80 per cent. on the contrary when they are rough, and when the superficial layer of creosoting has been cut by the rubbing against the

ballast. He has equally demonstrated that the addition of angles under the cross tie, in a word of projections able to give support against the ballast, sensibly increased the resistance to sliding by about 20 per cent. of the overload.

In the particular case, the wood ties being experimented with, having been placed for a long time in the track, ought to offer a maximum adherence; the coefficient reached 80 per cent. of the overload, that is to say, about 10,582 lbs., nearly the figure given above, 11,464 lbs. For the composite tie placed in the track at the same moment of the experiment, the adherence was not great, scarcely 60 per cent.; it was then 7,937 lbs., to which it was necessary to add the 20 per cent. due to the cross bars, 2,646 lbs. The total resistance would thus be, theoretically, from 10,582 lbs. to 220 lbs., near the figure obtained. The observations of Mr. Ferry are then completely confirmed.

Again, it ought to be remarked that the thickness of the cross bar or of the roughness ought to be relatively small, to have its full efficiency. A centimeter of protuberance suffices and it is easily conceived, for the tamped bed has no compactness, and only offers consequently resistance in its upper part. The maximum useful effect is thus produced on the surface of the ballast; an increase in the relief of the cross bars does not produce an increase in the resistance. That results from experiments made by the P. L. M. Co., and explains the results which have been found with a tie provided with cross bars.

CHAPTER IV.

DEFORMATION OF THE TRACK.

The sliding of the track, which is one of the most frequent deformations, and the most prejudicial to operation, is not, however, the principal one; others are produced of a permanent kind, which cause disorders in the track. While not primarily as grave, they occasion by their repetition serious difficulties. Among them may be mentioned creeping of the track, narrowing of the gage on tangents, or its spreading on curves; the compression of the wood at the supports, tearing out the screw spikes, and, finally, the shock which is produced right at the joint, and which causes the dislocation of the track and the vertical deformation of the rail.

All these deformations are caused by the longitudinal and transverse movements previously described. They are the consequences of them, to such a point that when these movements are diminished, the deformations are reduced at the same time.

CREEPING OF THE TRACK.

Rolling loads produce, in the direction of the movement of the trains, longitudinal displacements of the rails, which are ordinarily called dragging or creeping, and sometimes the entire track is drawn along. The ordinary methods employed for preventing creeping (notching of rails, anti-creepers, joint plates, angle bars) transmit, in a certain measure, the forces producing the longitudinal pushing of the rail to the fastenings as well as to the tie and to the ballast. The movement is more or less retarded, and the advance, whose effects are injurious, as I will show further along, diminished.

The rails are subjected in the longitudinal direction to two forces in a contrary direction; the driving wheels of the engine determine by their adhesion a reaction on the rails directed in an inverse direction to the travel; the carrying wheels of the engine and those of the other vehicles tend on the contrary to push the rail ahead. It is the last effects which are predominant, and experience shows that the longitudinal movement of rails always takes place in the direction of the trains on a double-track line.

But the longitudinal movement is not equal in the two lines of rail, even on tangents; when the road is double track the rail advances more rapidly in the line of rail on the outside (the left line) than in that of the inter-track side (right line).*

It results that the joints of the two lines of rail are no longer concordant; ties, especially those which act jointly with the rail, for example, the ties of the even-joint at the following end, are no longer placed normally with the track; the gage of the track narrows; the screw spikes lose their contact with the base of the rail. The overlapping of the joints, which in general are low, no longer allows the fall of the wheels at the passage of the joint to be simultaneous on the two lines of rails, and there must necessarily result from it zig-zagging movements for the engine and cars.

The longitudinal dragging causes as an effect the allowance for expansion at the joints to disappear when the temperature rises, the rails, no longer being able to expand, become compressed, and a zig-zagging movement can produce a lateral sliding of the track.

It is necessary, periodically, to put the rails back in place, and this operation is costly; Mr. Ferry estimates it at \$18.80 per mile per year on a line of average traffic. The longitudinal movement is therefore of real importance, and the principal causes which determine this forward movement should be sought.

Mr. Couïard estimates that the creeping (*Revue des Chemins de Fer*, August, 1896) ought to be attributed principally to the shock of the wheels at the passage of joints. It will be seen, further along, that the rails deflect at their extremities at the passage of the wheels, and that the latter fall from the advance rail on the following-rail, always more or less inflected, and produce a shock the more perceptible, the older the track is and the more deformed the rails are vertically. The wheel would act on the following-rail after the manner of a wedge, and would drive it before it.

This explanation of the advance movement is very proper, and is corroborated by a series of facts which Mr. Couïard has put in evidence in a very neat manner.

Thus, the speed of the trains increases the dragging; the latter is therefore maximum on the grades. Braking produces the same effect, since sliding friction is added, and creeping is very pronounced at the limits of stations.

On curves this movement is accentuated, especially on the line of rail of short radius, since the latter receives a larger part of

*Trains are run left-handed on the Paris, Lyons & Mediterranean.

the load by reason of the inclination calculated for the highest speeds, and since the sliding friction of the tire against the rail acts in the direction of movement. On the line of rail of long radius the movement has a tendency, on the contrary, to be produced in an inverse direction, in consequence of the cutting of the rail by the flange of the engine. This effect is diminished by the employment of the bogie truck, which enters the curves better. On a right alignment, the dragging is produced most thoroughly on the outside line of rail, in consequence of the unequal subsidence of the ties, a subsidence which consequently produces a greater loading on that side of the track. When the line of rail of the short radius is found at the same time on the outside, the two movements are conjoined and the dragging is greater.

The ballast acts equally either for increasing or diminishing the importance of the movement. Mr. Ferry has proved an advance of $\frac{2}{5}$ in. per thousand trains on track laid in a very variable ballast, that is to say, deprived of all residue by sifting, and freshly placed.

But the explanation given by Mr. Couïard has not been admitted by all the technicians; the shock which is produced by the passage of wheels from rail to rail doubtless has an influence, since the simple substitution of angle bars for fish-plates has diminished the creeping, but it ought to have other secondary causes, which act in the same direction, and which complicate the study of the phenomena. Thus Professor Johnson, at St. Louis, attributed the creeping of rails to the undulatory movement studied above, which is produced in consequence of the oscillation of the supports.

The resistance, which the friction between the rail and the tie opposes to the return of the points of rest of the rail on its supports, gives consequently a slow creeping of the rail in comparison with the ties.

The shock and the undulatory movement exercise a very serious action on the creeping; they are not, perhaps, the only elements susceptible of producing it. It has been seen, in fact, that, on a line of two tracks, each of which is only traversed by trains going in the one direction, the dragging of the rail is more sensible on the exterior side, that is to say, on the outside space. Mr. Couïard thought that this fact was due to the unequal subsidence of the ties, which tend to incline to the side where the ballast and roadbed present the least resistance. This explanation does not suffice, since the same anomaly is observed on lines with four tracks; it is always the left line of rail in the direction of movement which is submitted to the strongest dragging force. Other explanations have

been sought, such as the lack of symmetry of the engine, which would be more heavily loaded on the left, the position of Giffard, etc.; it suffices to cite them, in order not to retain any of them, for they do not rest on any precise observation.

The question then remains intact, and has not been entirely solved, in spite of all the interest which it presents; but it is necessary to retain the influence of the shock and of the undulatory movement, whose effect is of great importance, especially that of shock, as I have shown.

The author will endeavor to show, in the second part of this work, the methods employed for combatting the creeping, and to indicate those which should be adopted to arrive at a better result.

REDUCTION OF THE GAGE OF THE TRACK ON TANGENT AND THE WIDENING ON CURVES.

Mr. Couïard has pointed out, in very precise experiments, of which he has given an account in the *Revue des Chemins de Fer* for July, 1888, that in right alinement the rails are inclined to the interior of the track, and that on curved alinement the same movement takes place to the outside. He has equally proved that at the joint the rail in advance is inclined more than the following rail, and that the wheel falls from the first on the second.

The mean inclination on right alinement is as follows: With a good tamping of the tie, .067 in. on the advance rail, and .028 in. on the following rail (line of rail on the outside).

With a defective tamping, .08 in. on the advance rail and .04 in. on the following rail (line of rail on the outside). The line of rail on the outside should incline more than the line of rail of the inter-track space. The consequence of the unequal inclination of the two rails, advance and following, is to super-elevate the advance rail in comparison with the following rail, to provoke a fall of the vehicle, which withdraws considerable length of the following rail from contact with the wheels, and which increases at the same time as the inclination.

Mr. Couïard considers that this inclination would produce the same effect as if the rail were pivoted about the interior edge of its base. He has established that the jerk which is felt at the passage of joints cannot be attributed to the space left between the two rails for expansion, but to the unequal level produced by the unequal rotation of the two extremities of the rails. "The shock brings about, little by little, the unpacking of the tie at the following end of the even-joint, and the latter circumstance augments

still more the jerking at the passage of the joint, the lowering of the following tie tending to increase the unequal level of the two rails."

On a curve, the first axle of the train is that which most deforms the track. The line of rail on the side of the short radius is projected towards the center of the curve; the line of rail on the side of the long radius is, on the contrary, inclined to the interior of the track; the first axle only produces an inclination to the exterior.

Mr. Couïard has analyzed intelligently the phenomena of narrowing and widening of the gage of the track, but he has not perhaps given the exact reasons. If he has indeed seen that the widening of the track ought to be attributed to an exaggerated super-elevation given to the rail of long radius on curves, it does not seem that he has found the reason for the reduction of the gage of the track, which is produced on tangents.

I have shown, by numerous experiments, that the wood tie employed on railroads, bends in a very perceptible manner. The rail tends then, in consequence of this flexure, to be inclined towards the interior of the track, and this effect is again augmented by the compression of the supports and their deformation on the interior side, as we shall see further along, since the inclination of one-twentieth given to the rail, and the flexure of the tie, act in the same direction, and bring the weight of the load towards the interior. The unequal inclination of the two rails is also a consequence of the flexure, since the tie at the advance end of the even joint undergoes the maximum flexure and draws over the rail, while the tie of the following end of the even joint has not yet attained its complete deformation, and the imperfect splicing does not induce the two rails to act at the same time.

Besides, Mr. Couïard has implicitly recognized the causes given above, since he has proved that the placing of plates under the rails, distributing the load over a greater surface, diminishes the effect of the reduction of the gage.

COMPRESSION OF THE TIES RIGHT AT THE SUPPORTS.

The rails are fixed on the ties, whether it be directly or indirectly, by means of plates of support; in the first, as in the second case, but especially in the first, the wood is compressed excessively, and finishes by taking a permanent deformation.

In the bending tests of ties the lowering of the rail has been marked, apart from the points taken on the tie. This lowering,

which has always been found in excess of that of the neighboring points, gives the measure of the sinking of the rail on its support, and, consequently, of the compression of the wood. In order to appreciate its value, mean figures of the lowering of the points of the tie, situated on each side of the rail, have been taken, and the difference between these figures and those of the lowering of the rail have been given. The table on the following page, which sums up these calculations, brings out the fact that the sinking of the rail in its support is about twice as great with ordinary ties as with composite ties.

It is, however, necessary to remark that this reduced sinking is not due entirely to the reduced compression of the wood, but that, apart from this fact, it is also necessary to take account of the flexure of the tie, which increases the compression under the base at the inside edge of the rail, already greater by reason of the inclination of 1 in 20. But this flexure increases but little the effect of the sinking, for the slope of the bent tie scarcely reaches 1 in 400, a negligible quantity in comparison with the inclination.

Whatever the reason may be, the compression of the wood is produced, and it is a maximum on the interior side, because, for the reasons given, the loads are carried on this side. This coincides with the statement of Mr. Couïard, set forth in his article for July, 1888, in the *Revue des Chemins de Fer*; he has claimed correctly that the rail turns about its interior edge, which produces a super-elevation of the advance rail in comparison with the following rail, and determines a drop at the passage of the joint.

The increases of the resistance of ties to compression presents very great interest, and is intimately connected with the question which now occupies us, that is to say, the attempt to find out how to avoid deformations, in order to obtain a better circulation of traffic, and realize more considerable speeds. After the passage of trains, the rail returns to its primitive position; the base reacts on the head of the screw spike, tending to tear it from its socket.

PULLING OUT SCREW SPIKES.

The sinking of the rail in its support, the least bending of the tie, and the elastic reaction which results from it, exercise, slowly but surely, pulling effects on the screw spikes. At the end of a certain time, the screw spikes, which unite the rail with the ties, no longer hold, especially those which on a tangent are located in the interior of the track. They can be readily pulled out of their holes.

That is why a study of the fastenings is necessary; it is neces-

COMPRESSION OF SUPPORTS AND INCLINATION OF RAIL.

Figures for points
observed to the right and
left of the rail

No. of ties.	left of the rail		Mean figures.	Figures for the rail.	Diff. bet. the figures of cols. 4 and 5.
1.	2.	3.	4.	5.	6.

1. *Wooden Ties (P. M. rails)—Line of long radius.*

5	-14.5	20.0	17.2	18.0	0.8
6	25.0	19.5	22.2	26.0	3.8
7	15.0	21.0	18.0	20.5	2.5
20	13.0	19.0	16.0	17.5	1.5

Mean compression 2.1

Line of Short Radius.

5	24.0	21.0	22.5	26.0	3.5
6	22.0	23.5	22.7	26.0	3.3
7	27.0	24.0	25.5	29.5	4.0
20	25.5	21.0	23.2	27.0	3.8

Mean compression 3.6

2. *Composite Ties (P. M. rails)—Line of long radius.*

7A	23.0	22.5	22.7	23.5	0.8
7B	22.0	23.0	22.5	23.0	0.5
9	12.0	14.5	13.2	15.5	2.3
10	19.5	19.5	19.5	21.0	1.5
11	25.5	26.5	26.0
12	11.0	12.0	11.5	13.3	1.8
15	12.0	14.5	13.2	13.5	0.3
15	11.0	14.0	12.5	13.5	1.0
16	9.5	10.5	10.0	10.5	0.5
18	19.0	19.5	19.2	19.5	0.3
19	15.5	13.5	13.5	15.5	2.0

Mean compression 1.1

Line of Short Radius.

7A	32.5	37.5	35.0	35.0	...
7B	33.0	33.0	33.0	36.5	3.5
9	19.5	16.0	17.7	23.0	5.3
10	24.0	24.0	24.0	29.0	5.0
11	23.5	24.0	23.7	27.5	3.8
12	19.0	17.0	18.0	19.0	1.0
13	21.0	22.0	21.5	27.5	6.0
14	23.0	24.5	23.7	25.5	1.8
15	17.0	19.5	18.2	21.0	2.8
16	19.5	20.0	19.7	23.0	3.3
17	15.0	14.0	14.5	16.5	2.0
18	23.5	26.0	24.7	26.0	1.3
19	20.0	20.0	20.0	21.0	1.0

Mean compression 2.8

3. *Recapitulation.*

Wooden ties—line of long radius..2.1 Wooden ties—line of short radius..3.6
Comp. ties—line of long radius..1.1 Comp. ties—line of short radius..2.8

Difference in favor of Comp. tie..1.0 Difference in favor of Comp. tie..0.8

NOTE.—The figures are expressed in tenths of millimeters.



sary to know the limiting force which can be applied to the screw spikes before they can be withdrawn, and that which they can support before a spreading of the track .98 in. takes place, considered as sufficient to put it out of service; finally, the limiting force which can be imposed on it before obtaining excessive turning.

These experiments have been executed with two very ingenious pieces of apparatus devised by Mr. Albert Collet, and which he has

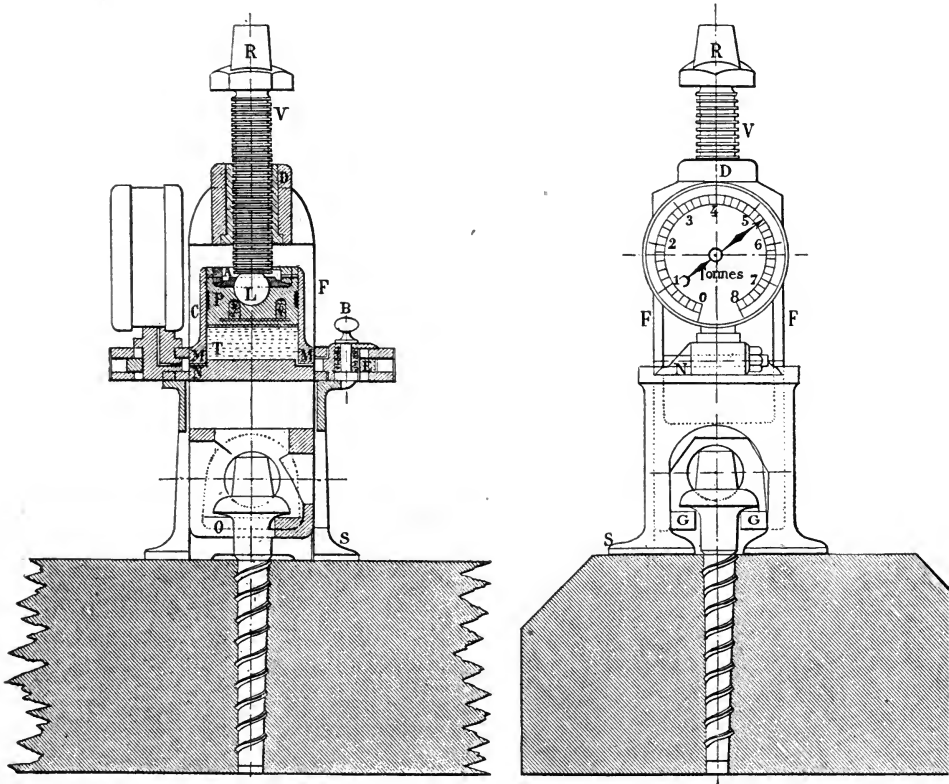

Fig. 13—The Extrahomètre, Vertical Section and Front View.

named the *extrahomètre* and the *déclimètre*. They have been used, as will be seen later, on ordinary and composite ties, with or without trenails, of which Mr. Collet is the inventor.

The *extrahomètre* is a very small testing apparatus, with register and with means for measurement, weighing only 13.23 lbs. and able to support a force of 8.82 net tons which is exercised vertically on the head of the screw spike, in the manner for extracting. This force is produced up to the moment when the wood is torn and

yields; at that moment there is no more resistance in consequence of more force.

This apparatus (Fig. 13), entirely of steel, is composed of a square pedestal, S, serving as point of support, through the opening of which is introduced the head of the screw spike, which is engaged in the foot of the dog, G. The foot of the dog is in one piece with the traction cheeks, F, and the nut, D, in which travels the motor screw, V, directed at R, by the key for screw spikes. Between the two cheeks is a cylinder, C, whose two flanges, N, rest on the pedestal. The cylinder contains liquid glycerine in T, and above, a piston, P, packed with leather, carrying a small ball, L.

At the extremity of one of the flanges, N, a pressure gage receives and records the pressure exercised on the liquid passing by the capillary conduit, M. B is a release latch, and E a symmetrical arrangement allowing the adoption of a standard, in order to verify the pressure gage in case of necessity. The travel of the foot of the dog is 1.57 in. This apparatus is in use by several railroad companies in France.

The table which follows gives the results obtained on composite ties:

COMPOSITE CROSS TIES.

Without treenails			With treenails		
Forces on screw spikes of the		Raise	Forces on screw spikes of the		Raise
Middle wedges.	Lateral wedges.	of middle wedges.	Middle wedges.	Lateral wedges.	of the middle wedges.
13,228 lbs.	0.04 in.	15,873 lbs.	15,983 lbs.	0 in.*
12,235 " †	0.02 "	15,983 lbs.	0 "
12,787 "	13,228 lbs.	0.0 " ‡
11,464 "	11,574 "	0.0 " ‡
13,228 "	13,007 "	0.0 " ‡
11,023 "	12,787 "	0.0 " §

Observations :

*Wooden wedges of creosoted oak, but split by frost.

†This wedge was split before the trial.

‡Mean force:—Middle wedge without treenail, 12,324 lbs.; lateral wedge, without treenail, 12,654 lbs.

§Mean force on the two wedges, 12,456 lbs.

The following table gives the results of trials on wood ties:

Nature of ties.	Forces on the screw spikes	
	Without treenails.	With treenails.
New oak ties, creosoted	13,668.5 lbs.	15,873.1 lbs.
Piece of new good spruce, creosoted.....	7,936.5 "	11,023.0 "

Apart from the experiments related above, and which were made in my presence, I have embodied the results of similar experiments executed by the employees of the P. L. M. Co., some days before. It was interesting to compare the results obtained with

a more complete series, in which the wood ties tested were with or without treenails. It is not necessary to give here the details of these experiments, it would be, in fact, going beyond the outline of the study which we have undertaken, but it is fitting to remember that the resistance to withdrawal of the screw spikes is the following:

1st. In pine ties	Approximately	7,716 lbs.
2d. In pine ties with treenails	"	11,023 "
3d. In new oak ties	"	13,228 "
4th. In new oak ties with treenails	"	15,432 "
5th. In oak ties in service for eight years	"	7,496 "
6th. In oak ties in service for 8 years, new treenails	"	12,125 "
7th. In oak ties with old treenails	"	7,496 "

The limit to extraction of the screw spikes in the composite cross ties is raised as an average to 12,456 lbs., that is to say, to a figure which is very near that which was obtained with new oak ties; the wood of the wedges was, however, of bad quality, presenting a good many fissures, and having all the appearances of being split by frost. Their own resistance was certainly inferior to that which it would have been if the material employed had been sound. The central wedge once in place, no longer rises, whatever may be the pressure to which the screw spike is submitted; the fastening is then secured in a certain fashion, and even more efficiently than it is generally, by reason of the compression of the fibers of the wood. The wedging, or rather the squeezing, of the pieces of wood, which one would consider *a priori*, as one of the weak points of a composite cross tie, becomes, on the contrary, one of its principal advantages; it seems that the bringing together of the fibers of the wood arising from the squeezing, gives to that material a resistance superior to that which it would have had in a free state. It is that which explains also the reason why the employment of the treenail in ties gives a superior resistance to that of the wood which constitutes them; the treenail has not, so to speak, any resistance of its own. That which demonstrates it, is that the limit of extraction varies according to the nature of the wood which envelops it, and which latter is, so to speak, the intermediary between the resistance of the treenail and that of the wood, which surrounds the latter. It follows that this resistance ought to hold the fibers of the wood envelope in compression more or less great, since the more fibrous and elastic the wood is, the more considerable is the resistance.

Thus the compression of the wood constitutes one of the principal merits of the tie, and in order to exhibit it, I have provided the wedges with treenails. The result has been what was expected;

the compressed horizontal fiber of the blocks reacted on the vertical fiber of the treenail, and the resistance was increased by about 20 per cent., that is to say, that with blocks composed of sound wood, fibrous and elastic, and with treenails introduced at the point where the fastenings are placed, a resistance was obtained which surpassed known limits. It was interesting, consequently, to make new experiments with that idea, and to see how cross ties, composed of wooden blocks of the kind indicated above, would behave. For that effect, cross ties provided with wooden blocks of horn-beam and elm were experimented with like the preceding, but unfortunately, the woods employed were absolutely baked, and the trials offered no more than a relative interest.

In spite of these very disadvantageous conditions, the results have nevertheless been very satisfactory, since there was obtained on a middle wedge a force of 19,621 lbs. (limit of power of the *extrahomètre*), and on the lateral wedges forces varying between 15,432 lbs. and 16,094 lbs. The results of this last experiment are set down in the following table:

COMPOSITE TIES.

Forces on the screw splkes of the wedges		Raise	Observations.
In the middle.	On the sides (lateral.)	of middle wedges.	
<i>1st. Horn-beam wedges.</i>			
14,330 lbs.	15,432 lbs.	Mean force on a lateral wedge, 15-300 lbs.
17,637 "	16,094 "	
14,110 "	15,432 "	These blocks were prepared specially for the tests; they were not creosoted, because they were not to be used in the tracks; they were in full process of decomposition, as we have been able to account for it to ourselves, having broken several of them.
12,346 "	14,992 "	
.....	14,110 "	
.....	15,983 "	
.....	14,330 "	
.....	15,983 "	
<i>2d. Elm wedges.</i>			
12,676 lbs.	13,669 lbs.	Wood as above.
13,779 "	12,676 "	
11,023 "	13,448 "	
10,472 "	13,228 "	
.....	11,684 "	
.....	13,007 "	
.....	11,905 "	
.....	12,566 "	

The object of the experiments with the *déclimètre* was to measure the bending of the tie and to bring about the overturning of the fastenings under increasing forces, having as an effect the spreading of the track to the limit (.98 in.), where it is considered as out of service.

This apparatus is essentially composed of a screw and nut, and rests on the heads of the two rails, under conditions similar to those of the wheel tires. The screw acts, through the intermediary of a ball and piston, on glycerine, which is contained in a reservoir, the pressure of which is registered by a pressure gage; it tends to spread the two rails, and the force causes the tie to assume a convex curvature. (See Fig. 14.) The displacement of the rail is registered and amplified by an independent instrument.

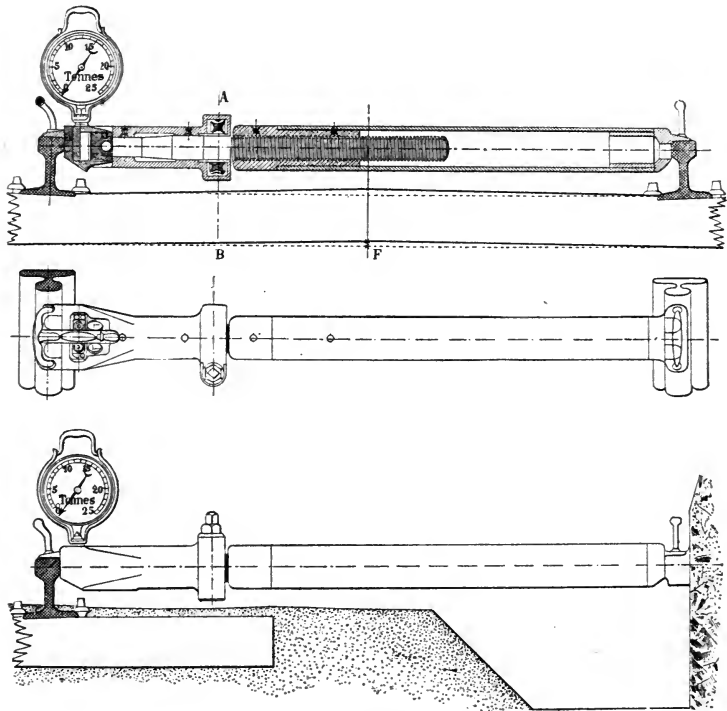

Fig. 14—Declimetre; Longitudinal Section, Plan and Elevation.

This apparatus serves also to measure the resistance of the track to lateral displacement, by supporting it against an abutment pier, and by acting on a single rail.

The experiments were made on composite and wood ties, at first in separate units, then by groups of two, each distant from the other (13.78 in.). The ties were placed on two supports, nearly of the length corresponding to that of the tamped bed. Steel ties in use on the state system were also experimented with, under similar conditions.

The apparatus was fixed, in the first case, in the axis of the tie to be tried, and in the second case, in the center of the two ties. In order to measure the curvature of the pieces, which it tended to produce, and which made known, so to speak, the degree of their rigidity, there was opportunity for estimating the importance of the flexures from their initial position which these pieces underwent. To this effect a right line was traced on the ties, whose two extreme points were placed near the ends of each of the pieces, and, at a given moment, the flexure in comparison with this line, now become curved, was measured, by describing with the same points a new right line, and by observing the departure of these two lines at the middle of their length.

This apparatus, which tended to spread the two sections of rail, acted at first on the tie, to induce its flexure; then, when this

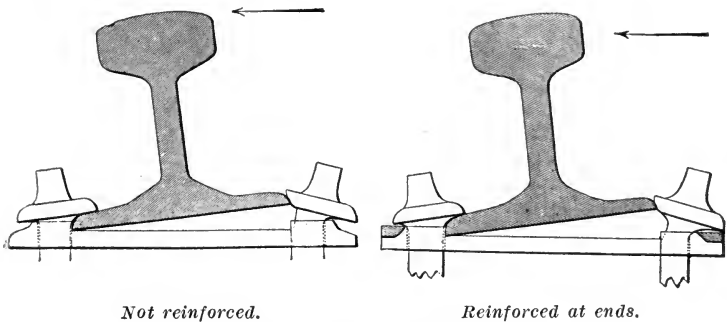

Fig. 15—Ordinary P. M. Tie Plate.

had attained a certain degree, which corresponded to the bending of the head of the screw spike on the plate, apart from its shoulder, the fastenings, principally those placed in the interior, commenced to be overturned, up to the moment when the base of rail escaped from the head of either of the interior screw spikes. (Fig. 15.) This effect was obtained without increase of force.

These experiments have shown that there was reason for consolidating the interior fastenings, and for increasing the number in comparison with the exterior fastenings. The good effect of the reinforcement of the plates in use on the P. L. M. system was also proved. In the type employed, the head of the screw is only partially sustained by the shoulder; it has then a tendency to overturn in the empty space until it meets the exterior part lying below the shoulder. There results a weakening of the fastening and a bedding of the screw spike which diminishes the resistance to this

kind of force. The rail is no longer maintained by the screw spike, and generally escapes from the fastening. In order to remedy this disadvantage, it is sufficient to prolong the shoulder of the plate on the exterior. In the trials which followed, the interior screw spike took the position indicated in Fig. 15, and the resistance to overturning was increased by 20 per cent.

The experiments with the *déclimètre* were carried on in like manner with the steel ties of the State System. The rails were fixed on the ties through the intermediary of steel plates, with an inclination of 1 in 20, and bolted on their upper surface. Three bolts per rail were used in the first test, two on the exterior and one in the interior; in the second, two in the interior and one on the exterior. The *déclimètre* was placed, as in the preceding experiments, in the axis of the tie. The forces were successively exercised, and were noted for each spread of the rails of .2 in.

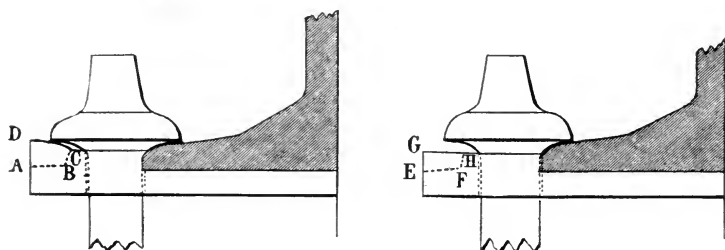

Fig. 16—Tie Plates Used on Wood (Left) and Composite (Right) Ties.

up to .98 in., where the track is considered out of service. The deformations of the beam, placed on two supports right at the rails, were read in comparison with the lower and horizontal edge of a steel rule, resting on invariable supports parallel with the tie. The latter was raised at the center in comparison with its original position, and lowered at its extremities; the curve of deformation was thus convex upward.

It would take too long and be without great interest to give the detail of all these experiments. They are summarized in the table on the following page.

This table shows: (1) that the forces were proportional to the number of interior fastenings; (2) that the forces sustained by the composite ties, provided with ordinary plates, were a little superior to those undergone by the wood ties, but that the inverse result was obtained in the experiments with reinforced plates. This fact

SUMMARY OF MAXIMUM RESULTS OBTAINED.

Designation of Experiments made.	Composite ties.		Oak ties		Steel ties of the State.			
	Forces.	Spreading. Flexures.	Forces.	Spreading. Flexures.	Forces.	Spreading. Flexures.		
Single ties.....	7,899 lbs.	One screw spike in the interior.	7,877 lbs.	0.95 in.	0.41 in.	8,267 lbs.	A bolt in the interior.	
		0.75 in. 0.18 in.						0.83 in. 0.47 in.
	16,314 "	Two screw spikes in the interior.	16,259 lbs.	1.08 "	0.82 "	18,298 lbs.	0.98 in.	Two bolts in the interior.
		0.18 in. 0.28 in.						
Reinforced....	8,303 "	One screw spike in the interior.	9,204 lbs.	1.02 "	0.51 "	
		0.77 in. 0.17 in.					
	16,755 "	Two screw spikes in the interior.	18,930 lbs.	1.31 "	0.81 "
		0.17 in. 0.43 in.						
Twin ties.....	18,960 "	One screw spike in the interior.	17,086 lbs.	0.98 "	0.36 "	
		0.98 in. 0.28 in.					
	*33,620 "	Two screw spikes in the interior.	32,518 lbs.	1.18 "	1.01 "
		1.18 in. 0.46 in.						
Reinforced....	17,968 "	One screw spike in the interior.	19,841 lbs.	0.98 "	0.46 "	
		0.89 in. 0.32 in.					
	35,677 "	Two screw spikes in the interior.	39,683 lbs.	1.38 "	0.89 "	

*This experiment was not continued since the maximum force was not reached.

can only be explained by the more complete reinforcement of the shoulder of the plates employed on the wood ties. In fact, for these latter pieces, the shoulder was prolonged in an inclined plane, C D, by adding a piece A B C D (Fig. 16), while we were satisfied, for the plates intended for composite ties, with a plane G H (Fig. 16), much less inclined; thus the heads of the screw spikes were found to be more supported on the first plates (Fig. 18), than on the second (Fig. 16), which explains the difference in the increase of the forces.

It may therefore be concluded that with plates absolutely identical, the forces would have increased in the two cases in the same proportion. Whatever it may be, no track is submitted in practice to the forces which were obtained, and these latter can always be considered as maxima, which will never be reached.

CHAPTER V.

DEFORMATION OF TIES.

The curves of deformation of these different ties, a deformation which was obtained by spreading the track, acting horizontally on the rails, are those which give the application of the theory, and the theoretical flexures are very close to those which were observed.

The moment of the flexure to which the wood and steel cross ties are submitted is constant for all sections; the curve of deformation, determined by the condition that the beam, resting on two supports right at the rails, is horizontal at the middle of the span, is then represented by the equation:

$$E I y = \frac{K x^2}{2} - \frac{K (la)}{2},$$

in which K represents the moment of constant flexure, l the half span of the beam, a the length between the extremity of the beam and the rails, by taking as the origin of co-ordinates the middle of the beam, and as axes the neutral line and the perpendicular erected at its middle.

It has been deduced from it that the total bending of the beam, which is equal to the sum of the flexures, at the middle and at its extremities, is given by the expression:

$$\frac{K l^2}{2 E I}$$

The table following permits a comparison of the observed and theoretical flexures, calculated as has just been described; the flexures obtained have been taken by attaching the rails to the cross ties with the screw spikes in the interior, which assures the greatest

solidity to the fastening, and an integral transmission of the force to the beam:

Value of the force.	Bending moment of tie		Flexures			
			Wooden ties		Steel ties	
	Wooden.	Steel.	Observed.	Theoret- ical.	Observed.	Theoret- ical.
2,205 lbs.....	180
4,409 "	360	0.40 in.	0.24 in.
5,291 "	432	323	0.26 in.	0.29 in.
8,818 "	720	0.64 in.	0.47 in.
9,920 "	810	605	0.44 in.	0.55 in.
11,023 "	900	0.80 in.	0.59 in.
13,228 "	1,080	0.78 in.	0.71 in.
13,669 "	1,116	834	0.59 in.	0.76 in.
15,432 "	1,260	0.75 in.	0.83 in.
16,259 "	1,328	0.82 in.	0.88 in.
16,314 "	1,332	995	0.69 in.	0.91 in.
18,298 "	1,494	1,116	0.91 in.	1.03 in.

Two observations may be made on the results set down in this table:

1. The theoretical flexures of the wood tie are sensibly equal to the flexures observed within the limits of elasticity of the wood, that is to say, in the case in question, up to a force of 11,023 lbs., corresponding to a bending of .79 in. When this bending is reached, it is remarked that, under increasing forces, the bending diminishes, which corresponds to a new state of the body, which takes a permanent deformation, and is extended while taking a less curvature. Besides, from this moment, the wood becomes brittle, and several ties were broken under the plate, where the weakest section is found by reason of the adzing for the plate.

2. The theoretical flexures of the steel tie are a little superior to those which were observed. The reason for it is the following: The plates of support for the rail were riveted to the upper surface of the cross tie and became a part of it. An increase of section results, for a notable length of the beam (about 23.62 in.), and, consequently, of the moment of inertia; the latter, which in the normal section is only 168, is increased by the moment of the plate, that is to say 256, a value which reaches nearly double the inertia of the section of the ties.

The latter has, then, from this fact, an exceptional rigidity, which explains the difference observed between the theoretical and recorded flexures.

STRESS OF METAL AND OF WOOD.

It is possible, after having studied the deformation of cross ties, to investigate the stress of metal and wood resulting from this deformation. It is given by the formula:

$$R = \frac{x z}{I},$$

in which R is the stress per unit of surface, x the bending moment, $\frac{I}{Z}$ the resisting moment of the beam.

The table which follows gives for each force the maximum stress to which the extreme fiber of the sections is submitted.

Value of force.	Moment				Value of force, in	
	Bending		Resisting		lbs. per sq.in.	
	Wood tie.	Steel tie.	Wood tie.	Steel tie.	Wood tie.	Steel tie.
2,205 lbs.....	180	135	18	30	355	6,400
4,409 "	360	270	711	12,800
5,291 "	432	323	853	15,645
8,818 "	720	540	1,422
9,920 "	820	605	28,589
11,023 "	900	675	1,778
13,228 "	1,080	810	2,133
13,669 "	1,116	833	39,498
15,432 "	1,260	945	2,489
16,259 "	1,328	992	2,617
16,314 "	1,332	995	47,164
18,298 "	1,494	1,116	52,910

It is observed: 1. That the wood tie was stressed, in the experiments accomplished, very near to the limit of elasticity of the material which composes it, since the latter is nearly 2,133 lbs. per sq. in., as was established in the study of the deformation. The result to be drawn is that a wood cross tie ought never to take a flexure greater than 0.40 in. under penalty of being exposed to rupture.

2. That the steel tie was stressed to a limit near that of rupture, 52,626 lbs., in place of 64,004 lbs. per sq. in., and that it has a resisting moment little higher, since, under a feeble force its stress reaches the limit generally admitted, 6,400 lbs. per sq. in.; it is true that the plate or the chair can reduce in a large measure the calculated stress.

CURVE OF DEFORMATION OF THE COMPOSITE TIE.

The composite tie can be considered as an armored beam, composed of a steel envelope and of a wooden furring; the union between these elements is so intimate, in consequence of the squeezing of the pieces, that these two elements may be considered to form an indivisible whole, the one coming to aid the other, to resist the

forces to which they are submitted as a whole. Such a solid may, therefore, well be compared to a beam of armored cement, in which the elements are associated in a manner so intimate, that each takes, within the limits of its elasticity, the part of the force which it can bear.

The experiments which were made on the sliding of the wedges, or the single wedge in the interior of the metallic body, have shown the good foundation for this conception. The tie was butted at one of its extremities

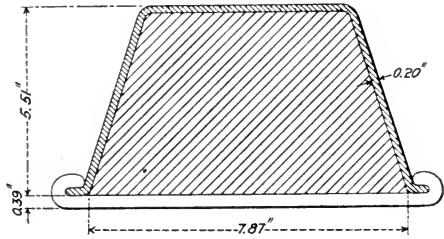

SECTION OF COMPOSITE TIE.

For these tests, rails, tie plates, and screw spikes were removed, leaving the wedges and blocks entirely free to slide in their envelope.

against a wall, or against a very solid obstacle; the *déclimètre* exercised its force against the other extremity (Fig. 17). The force which was thus exercised was raised to 15,432 lbs. before sliding began. This force is much greater than that which is necessary for bedding the fastenings, since a force of 1,543 lbs. suffices for overturning the head of the screw spike on the plate, which was displaced 0.4 in.; for a displacement 0.6 in. the force was raised to 5,732 lbs. It can be concluded from this that the fastenings will yield before either of the blocks has commenced to slide, and that the plate will never injure the flanges of the skeleton which surrounds it.

Each of the blocks thus forms with the metallic skeleton, a solid whole, which permits of calculating with exactness the forces which are developed in each of the parts of the system.

Three sections must be considered: the first, where the furring and the envelope are complete; the second where the envelope is defective in its upper part, that is to say right at the fastenings; the third where the envelope exists alone, without furring, which occurs at the extremities and in the central part of the piece.

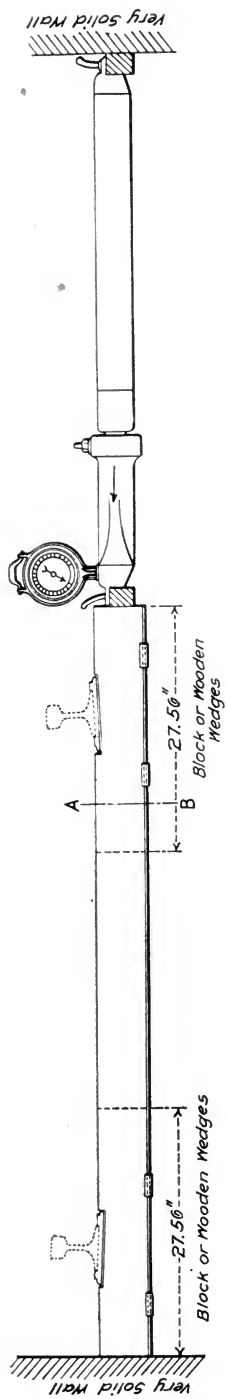

Fig. 17—Tests of Resistance of Blocks and Wooden Wedges of the Composite Tie to Sliding in Their Iron Body.

The table which follows gives, comparatively, the observed and the theoretical flexures calculated by graphical statistics (Fig. 18):

Value of force.	Bending moment.			Flexures.	
	1st Sec.	2d Sec.	3d Sec.	Observed.	Theoretical.
4,409 lbs.	337	377	325	0.12 in.	0.10 in.
8,818 "	674	754	649	0.16 "	0.20 "
11,023 "	843	942	812	0.21 "	0.25 "
13,228 "	1.011	1.130	974	0.23 "	0.30 "
15,432 "	1.180	1.319	1.137	0.28 "	0.34 "
16,314 "	1.248	1.394	1.201	0.28 "	0.36 "

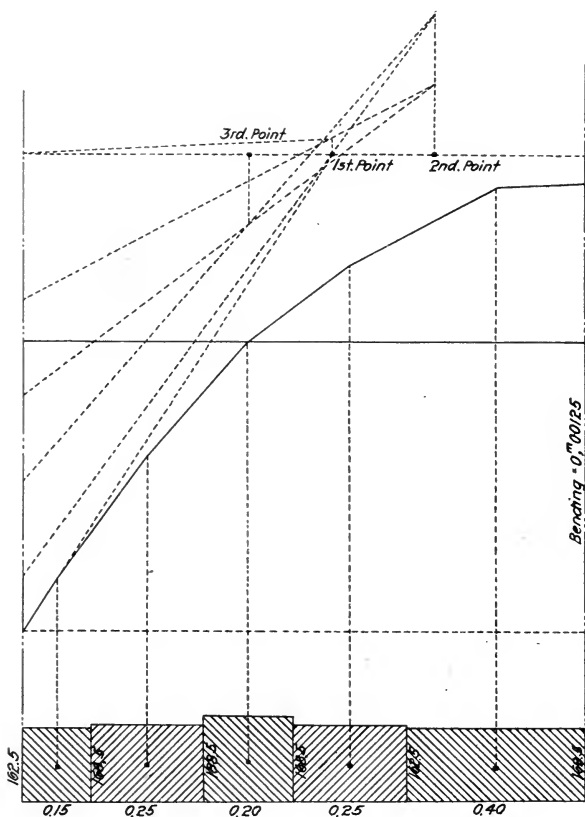

Fig. 18—Graphic Representation of the Bending of Composite Tie (Wood and Steel).

Amount of force.	Theoretical bending.	Amount of force.	Theoretical bending.
2,205 lbs.	0.05 in.	13,228 lbs.	0.30 in.
4,409 "	.10 "	15,432 "	.34 "
8,818 "	.20 "	16,314 "	.36 "
11,023 "	.25 "		

The theoretical flexures approach closely to the observed flexures; a little smaller under the initial forces, they surpass the results of observations by some millimeters, when the forces are increasing. It seems that the rigidity goes on increasing at the same time as the latter, in consequence of the still more intimate connection of the materials. This rigidity is apparent, for they are the supports which react and reduce the flexure.

Whatever it may be, this study proves that the theoretical bending of the composite tie is about three times less than that of the wood tie and of the steel tie, when these pieces are submitted to horizontal forces of 4,409 lbs., but that this superiority diminishes when the forces reach 15,432 lbs. (Bending of the composite cross tie about two times less.)

If one considers the composite tie as an armored beam, in which each of the elements is stressed, while taking the same elongation, proportionately to its coefficient of elasticity, one arrives at the following result for the three sections considered:

Value of force, lbs.	4,409	8,818	11,023	13,228	15,432	16,314
Bending moment: 1st section.....	337	674	843	1,011	1,180	1,248
" " 2d " 	377	754	942	1,130	1,319	1,394
" " 3d " 	325	649	812	974	1,137	1,201

Resisting moment, cu. cm. :

1st section—armored part....	1,764
2d " —notched part.....	1,066
3d " —center & extrmty	1,217

Value of force :

1st Sec.—Wood, lbs. per sq. in.	270	541	669	811	939	996
1st " —Steel, " " " "	5,405	10,810	13,370	16,214	18,775	19,912
2d " —Wood, " " " "	498	996	1,237	1,493	1,735	1,835
2d " —Steel, " " " "	9,956	19,912	24,748	29,869	34,705	36,710
3d " —Wood, " " " "
2d " —Steel, " " " "	7,567	15,133	18,917	22,700	26,484	27,991

In order to obtain the forces to which the elements of the composite tie are submitted, it was assumed that it was composed of a single material (wood for example), and the moment of inertia of the steel was augmented from this fact in the ratio of the coefficients of elasticity, that is to say, of 20 to 1. It has thus been possible to calculate the position of the neutral axis of the beam, supposedly homogeneous, and to deduce from it the stress of each of the elements, that of the steel being 20 times superior to the stress of the wood.

If the results set down in the table above are examined, and if they are compared with those which correspond to the wood and steel ties, it is observed that the stress of the material is much less in all the sections of the first than in the two others.

In the mortised part, the material is still stressed within an acceptable limit, 9,956 lbs. per sq. in., under a force very much superior to that to which it can ordinarily be submitted, but that part is quite short, and is reinforced by the plate, which compensates, and more, for the metal cut away for the placing of the fastenings. It is not the same for the steel tie of the State, which is too weak in each of its sections, except right at the fastenings, where it is equally reinforced by the plate or chair. Therefore, it may be said, that the composite tie tested presents two sections a little less resistant reinforced by the plates, while the tie of the State is weak over its whole length, except right at the fastenings. The two situations are, then, inverse with one another, and all to the advantage of the composite tie.

It is the same in the case of the wood tie, which is weak everywhere, and which has not a great rigidity, since it takes a flexure very much superior to that of the composite tie. In order that it may present the same stiffness, it would be necessary to increase the moment of inertia, which ought to be three times higher than that which is actually possessed, that is to say, that the latter should attain about $O m 00015$ in place of $O m 00005$. Supposing that the depth of 5.5 in. is maintained, which could not however be increased without difficulty, since it would be necessary at the same time to place a greater quantity of ballast above the tie, it ought to be given a width of 25.6 in., which is certainly inadmissible, for the actual base would be tripled. It is true that the same result can be obtained with ties 7.09 in. deep, 11.8 in. wide, but we believe that such ties would not be easily found, at least for the price, which would render their use impossible.

CHAPTER VI.

STRESS OF TIES IN THE TRACK.

The experiments on overturning, joined to those which have been related above on flexure, permit the determination, with a certain exactness, of the stress of the material composing the ties, under the effect of rolling loads.

In fact, it has been seen that the stress of the wood ties was 711 lbs. per sq. in. for a theoretical bending of 0.24 in.; for a mean bending of 0.10 in. observed on the cross ties with P.L.M.-A. rails, the stress will be about 299 lbs. per sq. in., that is to say, that these pieces are stressed about to the tenth of their resistance within the limit of elasticity.

As regards the ties with P.M. rails, the stress is 142 lbs. per sq. in.

The steel tie has a flexure of 0.10 in., which corresponds to a stress of about 5,405 lbs. per sq. in. (about one eighth of the elastic limit).

The elements of the composite tie are submitted to the following forces for a maximum bending of 0.012 in.:

	1st section.	2d section.	3d section.
Wood, lbs. per sq. in. . .	27	50	...
Steel, lbs. per sq. in. . .	540	996	754

The stress is thus for the steel, as for the wood, very much inferior to the admitted resistances, which would permit of reducing, from that point of view, the dimensions of the materials employed.

Space does not permit of discussion of stresses under moving loads, since these are notably inferior, as we have shown.

Apart from the forces of extraction and overturning, which are the most important, the screw spikes are exposed to excessive turning in their sockets, which reduces the pressure of the rail against its support. This disadvantage is produced above all at the moment of placing the screw spikes, and when they are retightened, the trackman can, if he does not give proper attention, exceed the force necessary, and render useless the work which he does.

The following limits are admitted as the force determining the excessive turning of screw spikes:

Pine, without treenail	132 lbs.
Pine, with treenail	176 "
Hard wood, oak or beech, without treenail.....	220 "
Hard wood, oak or beech, with treenail.....	242 "

The force is observed on a register which is attached to an apparatus invented by Mr. Collet, under the name of torsion meter, and which is placed on the head of the wrench for the screw spikes.

The company placed, about three and one-half years ago, 1,056 creosoted pine ties, provided with Collet treenails, on the line from Bourg to Chalon-sur-Saône. In the course of the month of August, 1902, after a traffic of about 13,500 trains, some trials were made with the torsion meter, in order to learn the resistance of No. 6 screw spikes against excessive turning.

The force necessary to obtain this effect on the screw spikes set in the treenails of the original placing, was 159 lbs.; it was 156 lbs., that is to say, sensibly equal, on screw spikes placed in new treenails, which were screwed into new holes, alongside of the treenails of the original placing, in the middle and at the extremities of the cross ties in service.

It is well to remark that while the resistance to excessive turning does not seem to be modified with time, that which the screw spike offers against extraction from a treenail appears to diminish. It is a fact which has been proved by Mr. Ferry, and of which we will seek the explanation further along.

Whatever it may be, it was desired to give an account of the resistance to excessive turning in composite cross ties, compared with ordinary cross ties of oak or pine creosoted. The results of these trials are condensed in the table below:

Kind of tie.	Limit of forces.	Remarks.
Composite ties—Lateral wedge of horn-beam without treenail....	231 lbs.	No excessive turning; at 231 lbs. the screw spike broke.
Composite ties—Lateral wedge of oak without treenail.....	231 "	No excessive turning; this force could not be exceeded by 2 men.
New ties of creosoted oak:		
Without treenail	220 "	Excessive turning.
With treenail	275 "	No excessive turning.
New ties of creosoted spruce:		
Without treenail	77 "	Excessive turning.
With treenail	242 "	Excessive turning.

These trials have shown that the resistance to excessive turning, for screw spikes placed in the blocks of the composite tie, that is to say, squeezed by the play of the skeleton and the cross bars, was at least equal to that of screw spikes placed in ties provided with treenails. The same cause ought to produce the same effects: the squeezing of the fibers of the wood, whether by the treenails or by the pressure exercised by the envelope, sensibly increases the resistance to excessive turning.

The good hold of the fastenings presents considerable interest; for, without an energetic tightening, the rail vibrates on its support, the track becomes jolty, and is deformed vertically, since it is no longer sustained. The tie is hammered, is raised up, and is buried by blows, which disorganize the ballast. This repeated movement, joined with the flexure of the tie and with the compression of the wood, disarranges the fastenings and provokes their tearing out. Finally, if the resistance to overturning is not assured, if the screw spike does not find a sufficient support in the ties, if it is not completely supported by its flange on the base of the rail, if the rail is pushed out, and that principally on curves, to the exterior of the curve, there is a spreading of the track and danger of accident. The track is deformed in the horizontal direction.

All engineers who have made a study of tracks, notably Mr. Couard, affirm that the joint is the weakest point. Mr. Freund, Engineer of Maintenance for the Eastern Railway Company, in a study of the most interesting and best recorded facts, appearing in the *Revue des Chemins de Fer*, January, 1897, pointed out the causes which rendered this point the most defective.

There is produced at the joints an unequal level in the direction of the travel of the trains, that is to say, at the passage of the vehicles, the rail in advance being higher than the following-rail, there is a drop. This unequal level of the rails at the joints is the result either of the juxtaposition of bars of different height, or of the unequal wear of the splice bearing points of the rails and the splices.

"The difference in the head of the rails is due to the inevitable imperfections of rolling. Sometimes it amounts to a millimeter from one rail to another, and from one extremity to the other of the same rail. It is possible, therefore, to produce jumps when the chances of laying put in juxtaposition, at the same joint, the extremities of the rails of different caliber.

"These jumps are ascendant or descendant, in the direction of the movement. But whatever may be the direction in which they

are presented, they provoke shocks at the advance end of the following-rail, which react on the splice bearing points of that rail, and promote its wear, while they are without influence on the bearing points of the rail in advance.

“As to the inequality of the splice bearing points, already thus prepared, its cause can be explained as follows, for the part which does not arise from the imperfections of the fabrication of the rails, and which is clearly shown in the joints where the rails are of equal height.

“In consequence of the compressibility of the wood of which ties are made, of the ballast and of the soil, the track undergoes under the wheels of the vehicles, a depression which, almost insignificant under light loads, can reach and even surpass 0.4 in. under the most heavily loaded wheels.

“This depression induces undulations in the rails, the amplitude of which, for a given resistance of the track to flexure or to sinking in the soil, varies with the load and the position of the wheels. It has in general, its greatest value under the first axle of the engines, when that axle is found in the middle of two successive supports.” (See the article of Mr. Freund, *Revue des Chemins de Fer* for January, 1897.)

It is the successive undulations which, bringing the different parts of the splicing in contact with the extremities of the rail, produce an abnormal wear of those parts, and determine the drop of the vehicles from the rail in advance to the following-rail, when the latter pass over the joint. Thus, it results from the examination of a very large number of splices that, in consequence of these oscillations on a line traversed in one direction, the following-rail, by resting on the splicing, makes a kind of notch, *b'* (Fig. 19), whose depth is at a lower level than that which the rail in advance produces at *a*.

When the load has passed the joint and encounters the following-rail, the latter is inclined, when resting at the bottom of the notch, *b'*, while the rail in advance is elevated; there is then a considerable fall from the advance-rail to the following-rail, as was found by Mr. Couïard, and that fall is due, except in the case where the rails present an unequal height, to the longitudinal movement of the track previously studied. The flexure of the tie of the following end of the even joint ought also to increase this effect, since the more this piece bends, the more is the difference of level between the advance and following-rails accentuated. The shock which is produced at the joint increases the flexure still more, be-

cause it determines the unpacking of the cross tie, which is found suspended at the end of a short time, and which assumes a still more pronounced curve.

The cause of the defective state of the track at the passage of the joint being well shown by the analysis of it by Mr. Freund, it was of interest to verify the manner in which a joint of a track provided with composite ties behaves, in comparison with what habitually takes place. If the theory of Mr. Freund is exact, the fall ought to be very much diminished when passing over track with composite ties.

Care was taken to observe the deformation of the track before any test, and as it was found that this deformation was increased, the profile was corrected by means of hoop iron wedges placed between the splicing and the head of the rail. Fig. 20 displays the condition of the joints before and after placing the wedges; the latter have reduced, at least by one-half, the slope at the extremi-

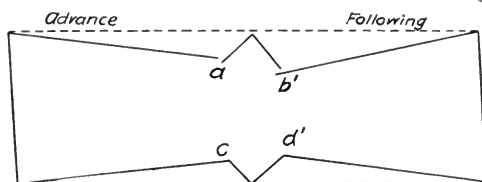

Fig. 19—Shock at the Joint.

ties of the rails, a slope which could reach about .08 in. in 19.69 in. The permanent deformation of the rails was still more apparent on track provided with composite ties than on that provided with ordinary ties, Fig. 21; that was occasioned by the fact that the P. M. rails, with which the section was provided, were very much worn, after long service.

The experiments were carried on in the following manner: Three cleats were fixed on both sides of the joint, at each of the extremities of the rails, on the upper part of the head. A steel rule placed on rigid supports allowed an estimate of the difference of level between the top of the cleats and the under part of the rule, by means of the wedge gage previously described. The first axle of the engine was brought right at the first cleat, and the profile of the extremities of the rails was observed; then the same operation was repeated by allowing the same axle to advance successively right at each cleat, and the same observation was made.

The result of these experiments is given in Fig. 22, in the left part of which are shown the successive sections of profiles of the P. L. M.-A. rails resting on ordinary cross ties; in the right part, the same profiles of P. M. rails supported on composite ties. The full line represents the original profile of the rails, the dotted line the profile deformed by the passage of the vehicle.

The original profile of the P. L. M.-A. rails is quite defective; there is, from the advance end to the following end of the joint, an unequal level of .064 in. at least; at the passage of the load over the joint there is a fall of .06 in. The successive profile of the two rails becomes quite discontinuous and more undulating.

The original profile of the P. M. rails supported on composite ties is better. At the joint there occurs an ascending step, which is rather unusual. The passage of the load improves the profile, which becomes almost continuous; there is an inequality of scarcely .012 in. when the load passes over the joint.

This is what is to be expected; it will be recalled, moreover, that the longitudinal movement of the track is much less strong when the latter is provided with composite ties, and that the joint does not undergo any oscillation during the passage of a load over the rail. The splicing is not then injured, as in the ordinary case; the shock which is produced is very much diminished by reason of this fact; the following tie is not unwedged, at least as rapidly. The unequal level of the advance end and following end is increased by this unwedging, but the unwedging is also an effect of the oscillatory movement of the track, and it becomes, in consequence, one of the causes for bad condition of the joint. This unwedging causes the tie of the following end of the even joint to bend more than otherwise, which increases the fall still more, due, for the most part, to the unequal wear of the splice bearing points. The composite tie, which distributes equally over the ballast the pressure which it supports, is not exposed, like the ordinary tie, to being unwedged; the fall at the joint ought then to be reduced.

However, it is difficult to make an exact and complete comparison between the results obtained on the track provided with P. L. M.-A. rails and those which have been found on the track provided with P. M. rails. This latter track is much more rigid than the first, and the movements which can be produced are of less importance. Similarly, the weakness should not reach, from this fact, the proportion of 1 to 3; but it is certain that it will be found, and will be as much greater as the tie is larger, and as the oscillatory movement is reduced.

The experiment performed under the conditions pointed out is therefore of importance. The unequal level which is produced by the passage of vehicles from the advance end to the following end has been observed in the static state; it is probable that it is greater in the dynamic state, by reason of the shock which takes place, and which is capable of increasing the movement.

I have not been able to prove it on the experimental track; moreover, the interest of such a measurement would not have been great, for the track conditions on a curve would have vitiated the test, or, at least, rendered it not precise. Nevertheless, I wished to proceed with the measurement of unequal level on track 2 of the line from Lyons to Geneva, particularly stressed and provided with P. M. rails. The ordinary splices, which united the extremities of the rails, presented exactly the aspect pointed out by Mr. Freund; that is to say, the bearing points of the splices were unequally worn, and the notch of the following end, in consequence of the repeated shock, was deeper than the notch of the advance end.

It was necessary, in order to have an exact proof, to photograph results. Mr. Louis Lumière, whose name is well known for his optical studies, established a special apparatus of the most simple kind, which permits registration on a photographic film. This apparatus is composed essentially of two acetylene lanterns at the center of two concave mirrors, each fixed to the extremities of the rails to be tested, and a sensitive film. The housing containing the film and the acetylene lanterns was arranged on a concrete block located about a meter below the track, in such a manner as not to be influenced by the passage of vehicles. The same film registered at the same time the displacement of the advance rail and that of the following rail. The experiment was performed at the passage of a freight train traveling at a maximum speed of 12.4 miles an hour.

Fig. 23 shows the depressions which are manifested at the extremities of the advance rail and following rail at the passage of each of the vehicles; the absolute magnitude of this depression is given by the difference between the position of the horizontal line representing the luminous ray before the passage of the train, and the lower points of the undulating line, determining for each extremity of the rail the oscillatory movement which it assumes at the passage of the train. The influence of each of the axles is clearly noticeable; between two axles the rail tends to raise up. The same effect is produced with more intensity between two vehicles. At the moment when the train is about to cross the joint,

the rail is slightly elevated, then it is lowered by a certain quantity, which appears maximum on the passage of the first axle.

The magnifying of the upper record is 3.79, the magnifying of the lower record is 3.91. It results that, after the photographic trace, the extremity of the following rail vibrated 0.35 in., and that the advance rail had a play of 0.14 in. The fall, when passing from the advance to the following rail, would thus be 0.21 in. It is not necessary to remark that this fall is very great, and that it indicates a joint in bad condition. It was thought desirable, in order to try the apparatus, to take a joint of this kind, allowing an appreciable vibration to be obtained. These results are, besides, comparable with those which are pointed out by Mr. Couiard in his article of July, 1897, on the vertical deformation of the rails (*Revue des Chemins de Fer*), for he estimates that the variable flexure of the rail at its extremity is 0.12 in., and that the compression of the ballast reaches 0.12 in.; the bending which it can take is, then, 0.24 in.

It matters little whether the flexure does or does not reach this limit; it suffices to prove that it is of real importance, and that it ought to be reduced.

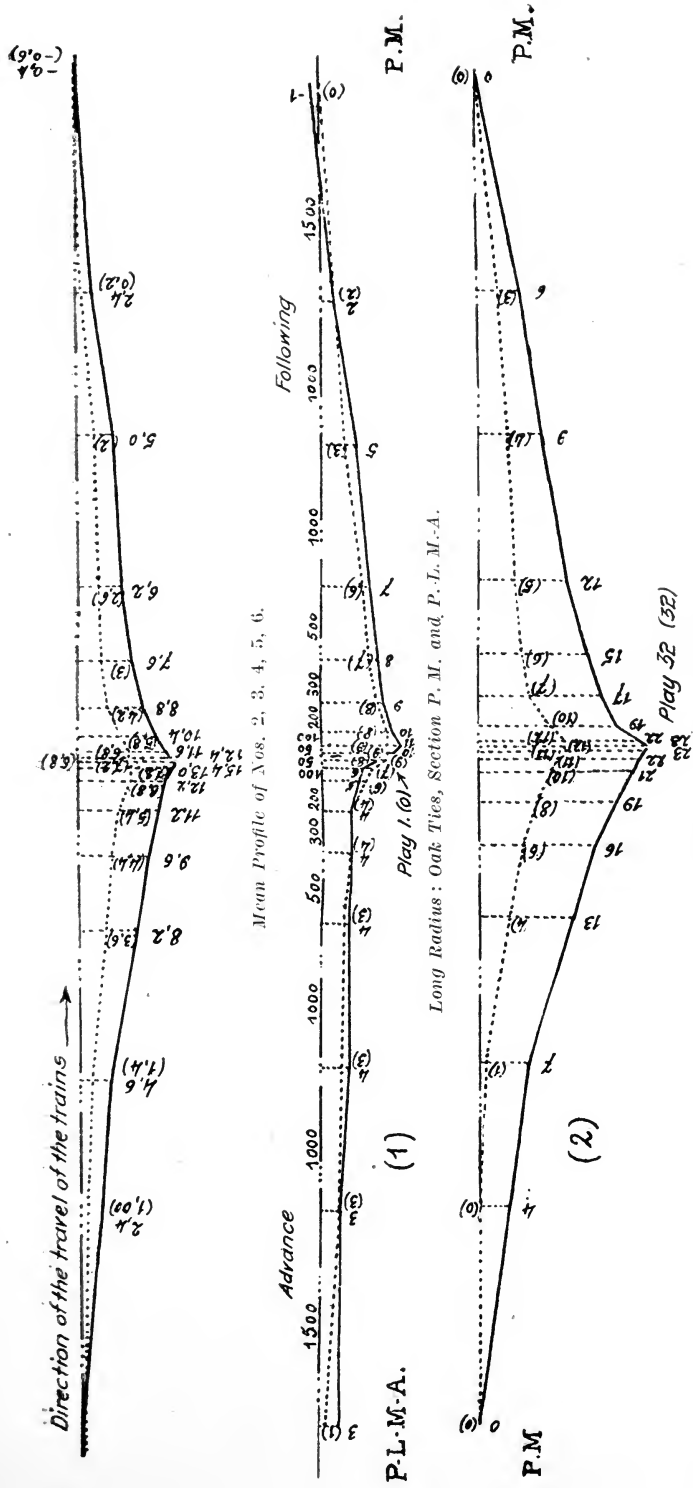

Composite Tics, P. M. Section.
 Fig. 20 (See Explanation, Page 97).

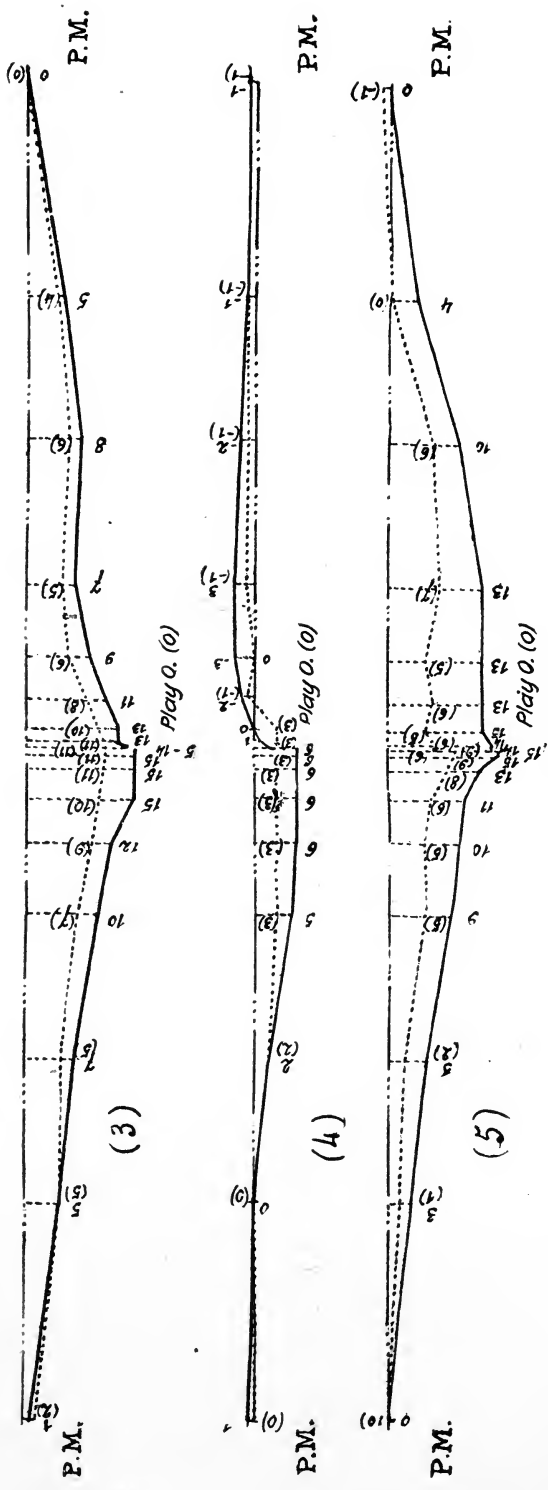

Composite Ties, P. M. Section.

Fig. 20, Continued (See Explanation, Page 97).

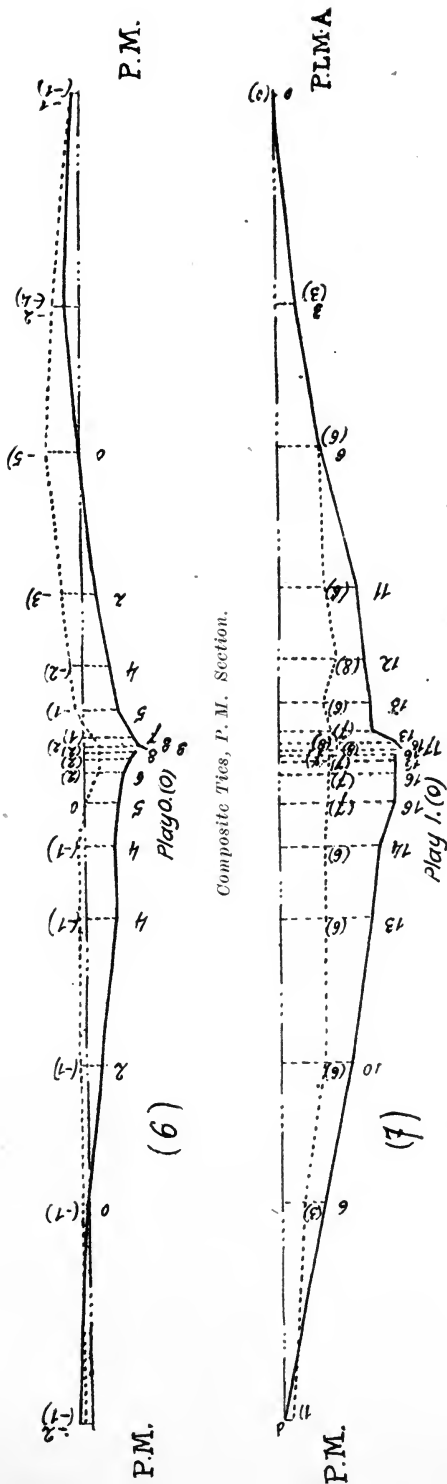

Oak Ties, Section P. M. and P. L. M.-A.

Fig. 20, Continued—Condition of the Track at the Joints, Before and After Wedging. (Long Radius.)

Full lines indicate condition of joints immediately after laying composite ties. Dotted lines indicate condition of joints after wedging rails up. The figures are in tenths of millimeters.

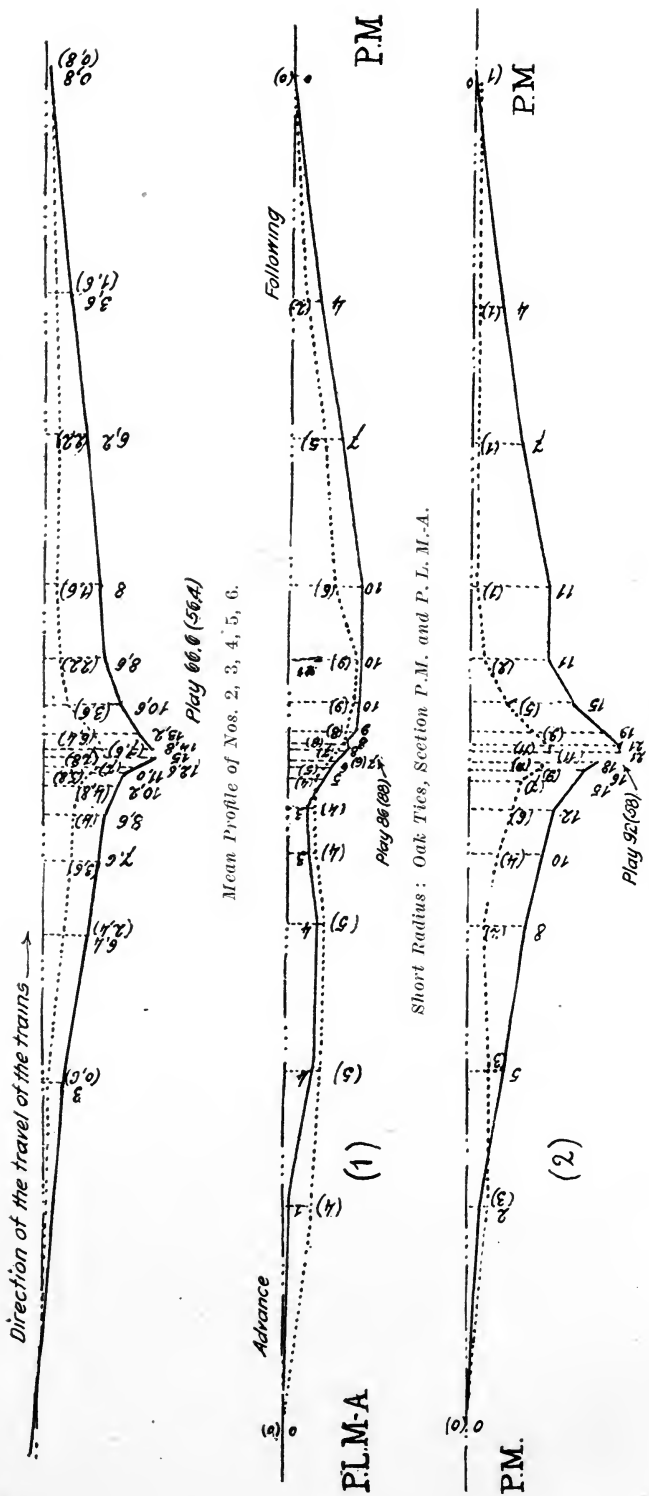

Composite Tics, P. M. Section.
 Fig. 20, Continued (See Explanation, Page 100).

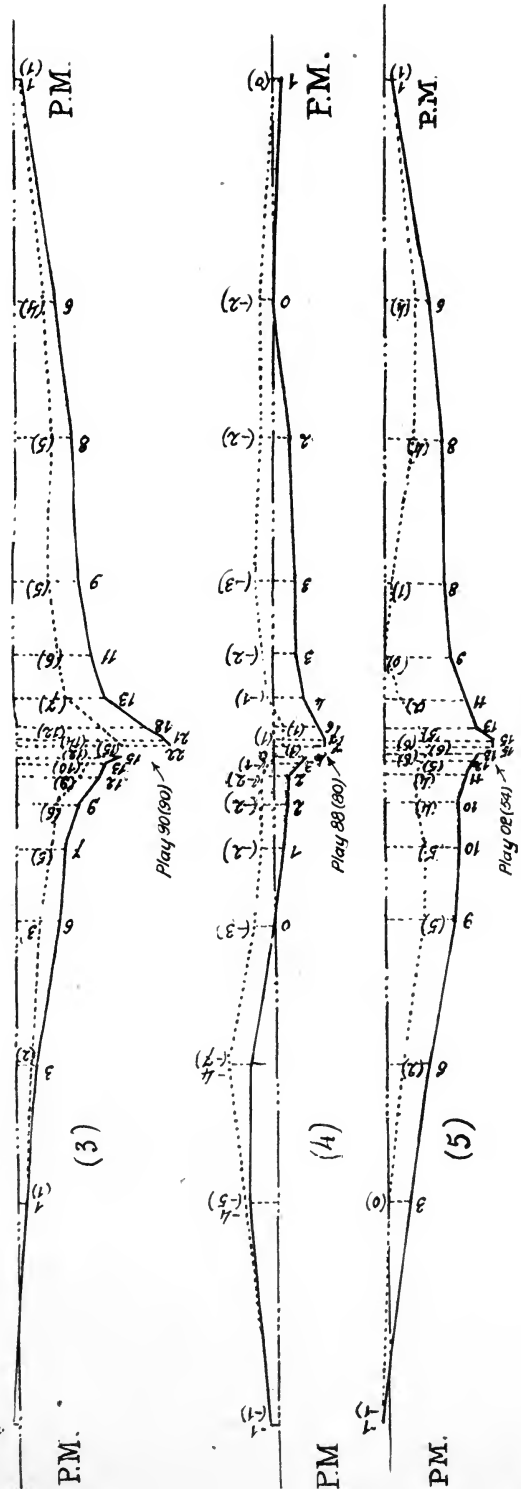

Composite Ties, P. M. Section.

Fig. 20, Continued (See Explanation, Page 100).

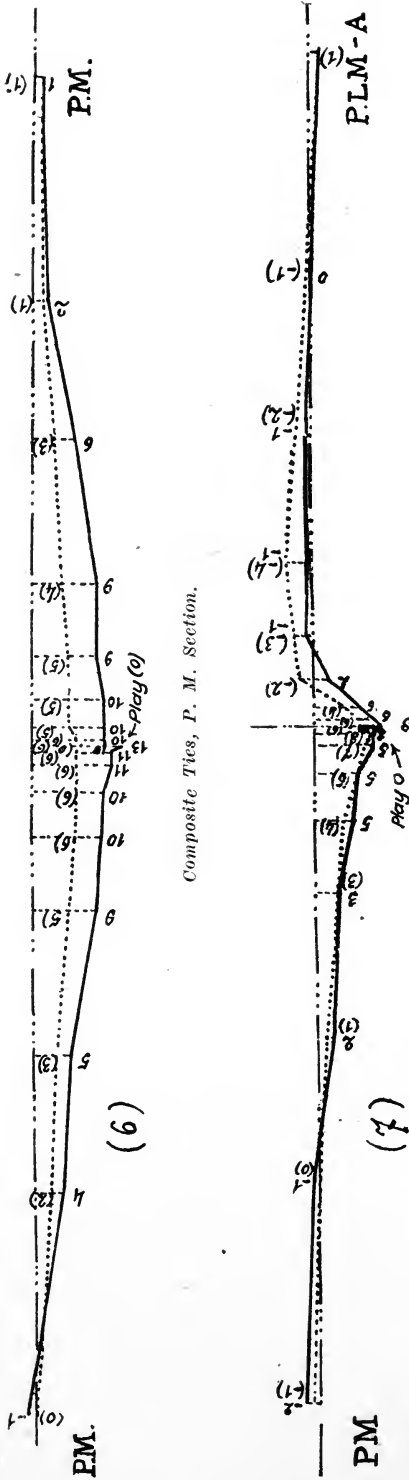

Fig. 20, Concluded—Condition of the Track at the Joints, Before and After Wedging. (Short Radius.)

Full lines indicate condition of joints immediately after laying composite ties. Dotted lines indicate condition of joints after wedging rails up.

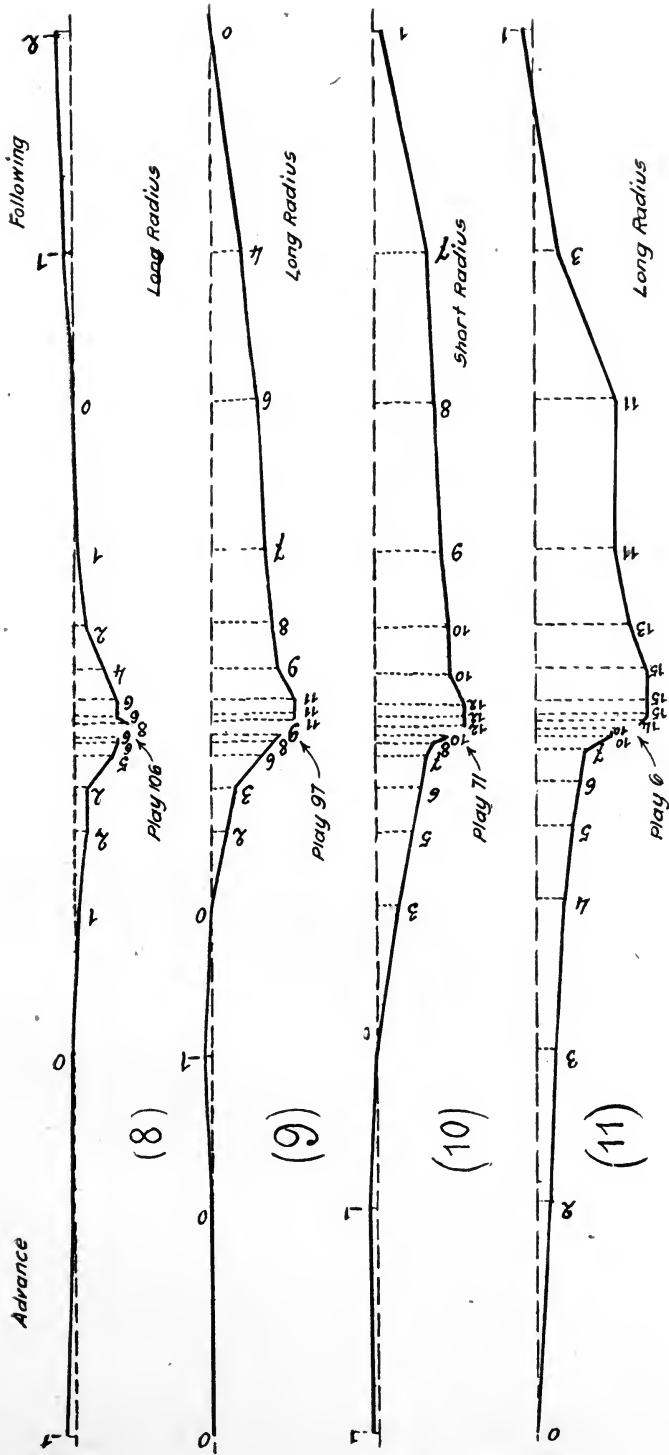

Fig. 21 (See also Following Pages).

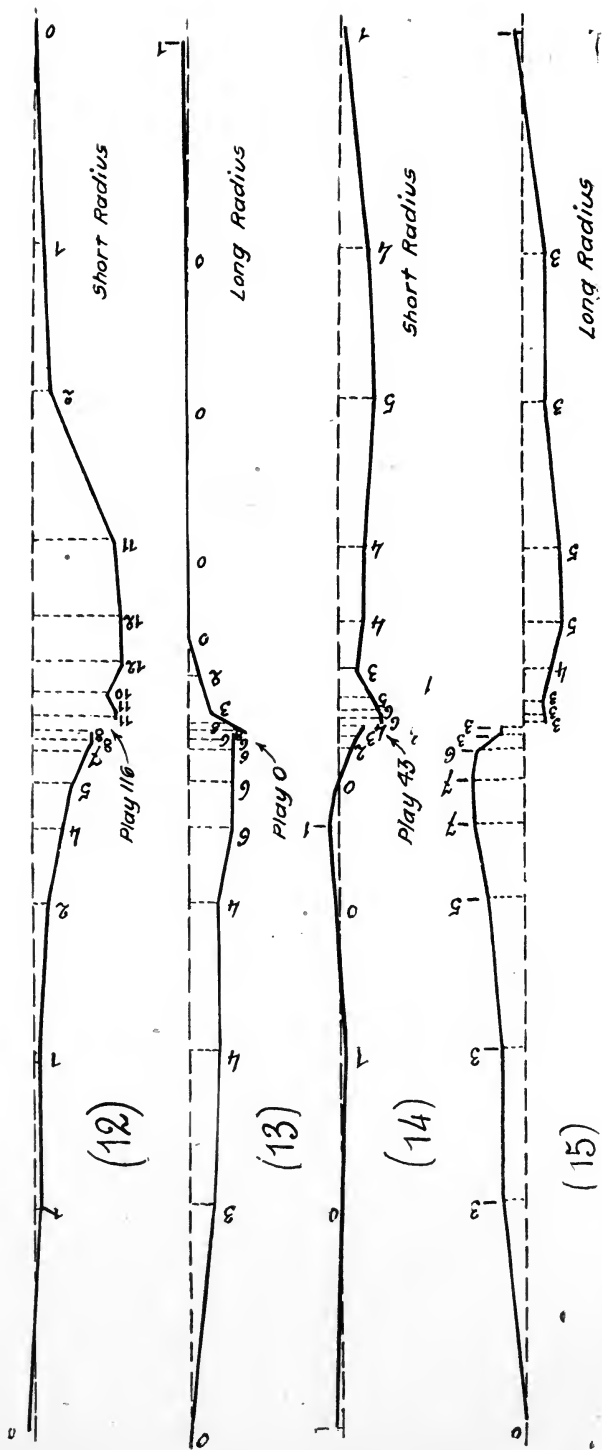
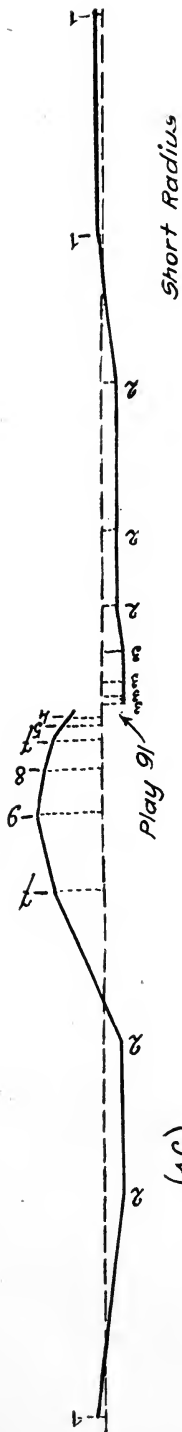
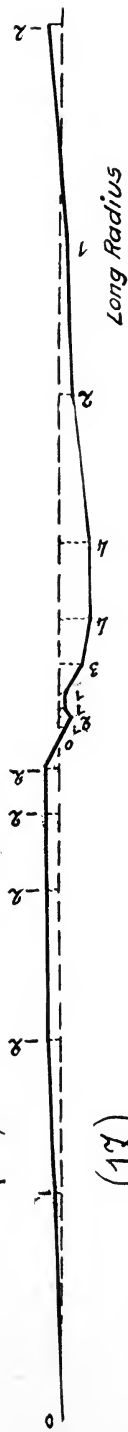

Fig. 21, Continued.



(16)



(17)

Fig. 21, Continued. P. L. M.—A Track (Angle Bars).

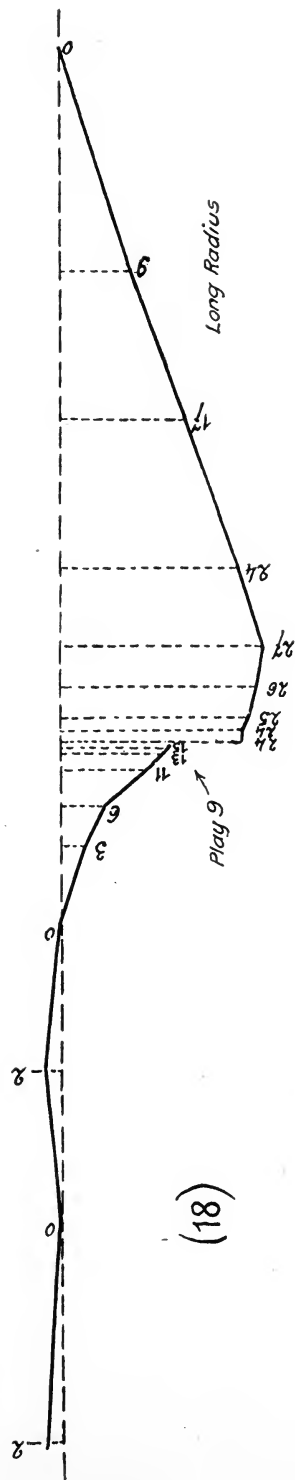

(18)

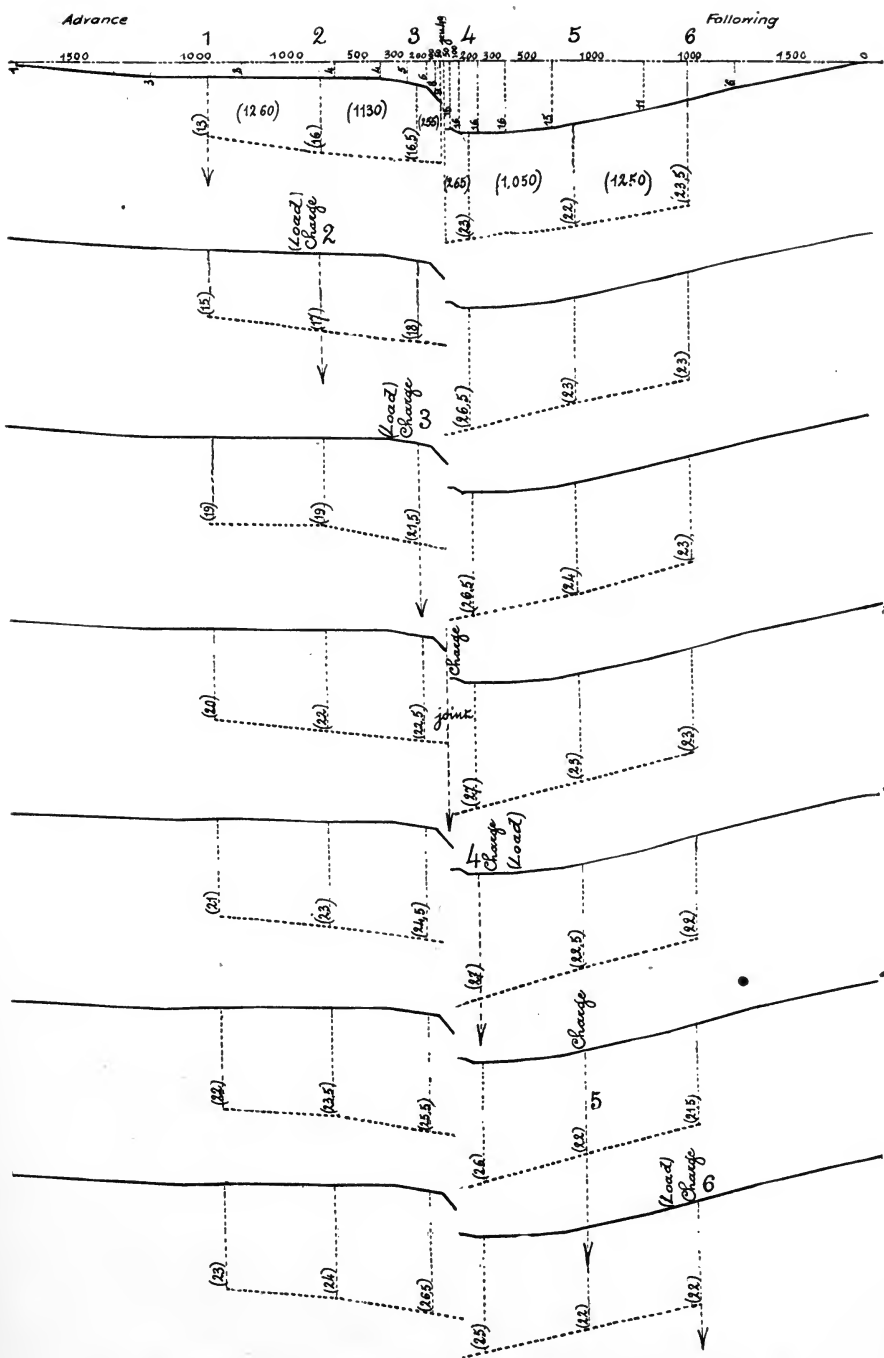

Fig. 22—Depression at the Joint at Passage of Train, Oak Ties.



Fig. 23—Photographic Records of Movement at Joint. Upper Record Magnifies Movement 3.79 Times; Lower Record, 3.91 Times.

CHAPTER VII.

STUDY OF WOOD USED FOR TIES.

Hard woods are principally used in France, oak or beech being preferred, but when these are not easily obtainable, or are too expensive, pine is used; but these woods are not utilized as they are found in commerce. They are first submitted to preservative processes, creosote generally being used. The timber, as purchased, is not that of the first quality used for framing—which costs in France 120 francs per cubic meter, say \$55 per thousand feet b.m.—but second quality wood is used, especially second quality oak. The price of sap wood and wane oak, prior to the preservative process, is about \$20 per thousand feet, while beech costs about \$16 per thousand feet. Thus the untreated oak tie costs about 87½ cents and the untreated beech tie about 68 cents.

Beech makes an excellent wood for tie purposes, but is difficult to preserve and becomes worm eaten very rapidly if it is not allowed to dry under favorable conditions, especially if the bark is not removed after the tree is cut down. Pine wood is quite resistant to compression but, owing to the loose texture of its fibers, it resists poorly the tearing caused by the fastenings and has a shorter life in service than the harder woods do unless the fastenings are made in a way which will be discussed further on.

Mr. Michel, Chief Engineer of the P. L. M. Company, has made a study of the relative compressibility of these species of wood to the limit of permanent deformation. According to him the resistance to compression of oak or beech, common pine, larch or spruce is as follows:

Species of wood.	Perpendicular to fibers.	Parallel with the fibers.	Proportion.
Oak or beech.....	3,413 lbs. per sq. in.	2,560 lbs. per sq. in.	.75
Common pine	2,845 " " "	2,133 " " "	.75
Larch or chestnut	1,707 " " "	1,138 " " "	.75
Spruce	1,138 " " "	683 " " "	.60

But this resistance to compression varies considerably according to whether the wood is treated or not, and also according to whether or not it is sustained between the walls of an envelope, as in the case of the composite tie. In the first case, with treated wood,

the resistance to compression diminishes, as will subsequently be shown. In the second case, however, that of the composite tie, it increases very materially because the wood held fast between the walls of the metallic frame is sustained and the fibers have less play in relation with each other.

But before discussing these questions mention should be made of the process of treatment which is employed, since this has a considerable influence on the durability of the tie and consequently on its steadiness in the track. The experiments made have been carried on principally with beech, but the information derived can easily be extended to other kinds of wood. The quantity of creosote which can be used depends upon the amount of moisture in the wood which is being treated; therefore, the seasoning of the wood must first be considered.

In the first experiment, pieces of beech wood 9.84 ft. long, 6.3 ft. high and 6.3 ft. wide were cut immediately after the tree had been felled and were placed in rows on supports under shelter, to be seasoned. These pieces of wood, which contained on an average 45 per cent. of their weight of water in the beginning, were weighed separately, at first every 15 days and then at longer intervals. The successive losses of moisture are given in the table on the following page.

This wood was clearly not piled under conditions, as regards seasoning, identical with those of ties piled in the ordinary manner, since these are exposed to the weather and would presumably be slower in drying, but the extreme limits of seasoning remain the same; that is, the maximum of moisture at the beginning will be 45 per cent., and at the end it will be about 21 per cent. These limits are sufficiently accurate for the discussion which follows.

It will be seen by the table given that nearly the maximum seasoning was obtained in $4\frac{1}{2}$ months after felling, from the first of May to the 15th of September, during the fine season. From the 15th of September to the 15th of February following the percentage of moisture of the wood remained stationary around 22 per cent., with slight fluctuations; then, during the fine season following, up to October, 1897, the rate of moisture descended to 20 per cent.

According to previous statements, beech wood, after six years of seasoning under shelter, still contained from 10 to 12 per cent. of moisture; but from the point of view of practical drying of ties, it is scarcely possible, without stove drying, to lower it below 22 per cent. of moisture.

TRACK DEFORMATIONS.

Table of Losses of Moisture.

Periods of weighings.	Duration of seasoning.	Successive proportions of moisture remaining in the wood at each weighing.	Character of wood, according to the degree of seasoning.
1896.			
1st May.	Beginning.	44.6 per cent.	From 45 to 40 per cent. of moisture some days after felling, the water flows from the wood and forms pools at the foot of the pieces when they are on end.
15th May.		38.0 "	
1st June.	1 month.	31.6 "	From 40 to 35 per cent. of the wood still surcharged with water appears translucent at the surface, when it has just been cut; the fresh shavings are semi-transparent when interposing them between the eye and the light.
15th June.		28.6 "	
1st July.	2 months.	26.5 "	
15th July.		24.5 "	
1st Aug.	3 "	23.0 "	Below 30 per cent. moisture, it is difficult at first sight to state the degree of seasoning.
15th Aug.		22.5 "	
1st Sept.	4 "	22.0 "	With 20 per cent. of moisture, it can be said with certainty that the wood has arrived at its maximum practical seasoning without stove-drying, because it will scarcely dry more when exposed to the air another year.
15th Sept.		21.8 "	
1st Oct.	5 "	21.7 "	It is probable that the ties in the middle of a pile could not attain this degree of seasoning.
15th Oct.		21.6 "	
1st Nov.	6 "	The wood after 5 to 6 years of seasoning under shelter, still contains 10 to 12 per cent of moisture.
1st Dec. 1897.	7 "	
1st Jan.	8 "	
1st Feb.	9 "	21.8 per cent.	

The quantity of water contained in pine is at least equal, if not greater than, that which is found in beech, that is to say about 45 per cent. immediately after felling and 20 per cent. after seasoning. It is not the same in the case of oak; the percentage of moisture which it possesses is certainly less, the fibers of the wood are more compressed, and the quantity of water which they enclose more restricted. It is difficult for me, for want of precise experiments, to give an exact figure; it can be said, however, that this wood dries very slowly, keeps its moisture a very long time, and absorbs, consequently, a very small quantity of creosote. On this account, it is difficult to say when the preservation process can best be undertaken. This refers to the heart of the wood, not to the sap, which loses its water very rapidly.

When cross sections of new beech cross ties creosoted with 35 lbs. and containing much moisture (30 per cent. for example, which is very common), are immediately examined after the injection has been made, it is noticed that the creosote has penetrated into the end by the annual layers of the autumn wood, and that the spring wood, though considered more porous, has not been absolutely impregnated; the wood resembles a series of concentric rings alternately creosoted or intact.

The sections, made quite near the extremities, show the wood impregnated for a certain distance without alternations; at 3.94 in. the rings commence to be defined, 7.87 in. they are very clear, and occupy nearly the whole section of the wood. (Fig. 24.)

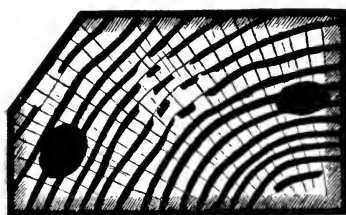

Fig. 24.



Fig. 25.

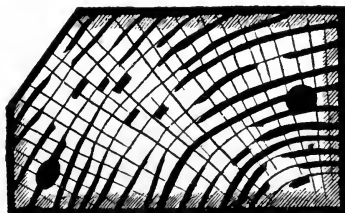

Fig. 26.

But proceeding towards the mortises for plates, the notable portions of these rings disappear (Fig. 25) and become more rare in proportion as they approach the middle of the length, where, often, there is no longer any trace. (Fig. 26.)

On the other hand, it is seen that the creosote has also penetrated through the lateral surface, by reason of the degree of moisture in the wood; above 35 per cent. there is almost no more penetration, scarcely two to three millimeters (0.08 or 0.12 in.), sometimes none; towards 30 per cent. the creosote has penetrated to a depth of two to three millimeters (0.08 to 0.12 in.), for the color of the wood goes on getting weaker in the direction of the depth.

In the moist wood, as above, there exist few cracks arising from seasoning; when they are observed they are in the direction of medullary rays, not penetrating to more than two to three centimeters (0.79 to 1.18 in.), and the creosote has penetrated a little deeper by them. These cracks do not follow the meshes, but form freely among them.

If a transverse cut is made at the extremity of a beech tie injected with 35 lbs., freshly creosoted in the moist state (30 per cent. for example), it is observed that the concentric rings of the annual layers form alternations of wood creosoted and not creosoted; but by leaving the piece of wood of small sectional volume in the air, the rings of creosote, clearly limited and defined on the cut surface, spread out by the seasoning and the creosote is diffused in the circular intervals of wood previously intact. When this piece of wood has finished drying (which requires one or several days, according to the thickness of the piece and the temperament), the creosote is diffused in a diluted greenish tint, which sometimes occupies the whole mass. In the sections of these moist ties made towards the mortises for plates, or towards the middle of the tie, are parts the least injected, where, at the moment of making the section, only small portions of wood creosoted are seen, the diffusion on drying is exceedingly slight.

But if these samples of wood imperfectly creosoted are preserved in moist sand, no diffusion apparently takes place. According to that it would seem that there was advantage, for the diffusion of the creosote, in keeping the ties after creosoting exposed for a long time to the air, but it is observed that this diffusion, which is well done, and within a short time, with the small samples, is much slower with the ties exposed to the air.

On the other hand, the tie from which the piece in question has been cut, is preserved even in the air with its tints in rings, without any diffusion, during several months, and to such a degree that it keeps at least 30 per cent. of its original moisture; once placed and buried in the ballast, it losses or absorbs moisture very slowly, according as it is more moist or more dry than the medium surrounding it when it is first placed in the track. When it has reached the degree of moisture of the ballast, the latter diminishes or increases according to the seasons. In ties weakly creosoted with 35 lbs. in pure gravel ballast, in position for at least five years, the wood not injected, in the interior of the tie, contained from 30 to 35 per cent. of moisture in the month of September, after a month of dryness and an ordinary summer; in a ballast

of broken stone this proportion of moisture is much less, from 20 to 25 per cent., which favors diffusion.

In these kinds of ties the impregnation is generally produced by the rings of autumn wood; it was not diffused, and the rings, although compared, remained in their primitive state. The limiting amount of moisture at which the diffusion commences to work is not known, but it is evidently less than 30 per cent.

When the amount of creosoting is reduced from 46 to 35 lbs., beech ties are imperfectly creosoted, and the white wood* not creosoted appears on the mortise for the plate, that is to say, at a distance of a centimeter (0.39 in.) from the surface. With the aid of a special auger, numerous samples of untreated wood were taken from these ties, and from 30 to 35 per cent. of water was found. When they have 30 per cent. moisture they are only superficially creosoted, except at the extremities over 9.84 in. long, where the injection has penetrated without reaching the mortises for plates. Some ties of this nature employed in the annual track renewals from 1889 were submitted to a special examination. By sounding them from time to time it was proved that they were rapidly worm-eaten, and that at the end of four years a large number of them, from 15 to 30 per cent., according to their position in the track, commenced to decay in their interior; 10 per cent. were already replaced at the end of this short lapse of time.

In all the ties studied, the decay followed the same course. There is first produced the heating or the spotting of the wood not creosoted, situated immediately under the superficial crust penetrated with creosote, and that over the upper part of the tie, which is not covered up and is placed in the interior of the track. The spotted wood is that which has heated before seasoning by the fermentation of the sap moisture; in the beginning, the color, generally clear yellow for beech wood, commences to be spotted with characteristic white points, then to be marbled with yellowish spots; the fibrous contexture disappears, the wood becomes

*The wood, which remains with its natural color without any trace of injection, is called white wood in beech; the most common color of beech is clear yellow; it is often white as poplar; exceptionally, it is reddish. The heart wood, which appears towards the age of 30 to 35 years, is red, very hard and appears to be proof against the injection of an amount of 33 lbs. Untreated heart wood is not found in the cross ties of 1877, subjected to 55 lbs. of creosote. All the wood in these old ties is strongly impregnated with creosote. The whole of the wood is strongly impregnated with creosote.—*From the report of Prof. W. K. Hatt, to the American Railway Engineering and Maintenance-of-Way Association.*

spongy, becomes yellow colored,* and the shavings which are cut have no body and crumble. (Fig. 27.)

The next process is that the heating gains in depth and reaches all wood not creosoted, which affects the shape of a spindle on the longitudinal section of the cross tie, and is terminated in a fish tail towards the fastenings; the wood which is spotted and has first become yellow under the creosote crust of the surface, still intact, assumes a brown color, of touch-wood, and seems to be calcined. The tie preserves a very good appearance on the exterior, and the wood under the fastenings remains quite sound. (Fig. 28.)

The creosoted superficial crust of the top next yields and is broken towards the middle of the inter-rail space; it forms a trough in the decayed wood, where water accumulates, and promotes decomposition. The decay reaches the fastenings more or less rapidly, which often hold sufficiently well, above all those of the exterior, but the tie is out of service. (Fig. 29.)

Some hundreds of decayed ties taken out of the track have been examined, and samples were taken from more than 10,000 ties in service, commencing to decompose; the same process of decomposition has always been observed in ties injected with 35 lbs. Beech wood very sound, but moist with sap, not injected, imprisoned in the superficial bed of creosoted wood, which prevents that sap from evaporating, becomes heated and decays rapidly by commencing at the part contiguous to the face free from ballast, exposed to the sun, which first becomes spotted.

A very conclusive experiment was tried on this subject, which is easy to repeat; there was available in the spring a half tie of very sound beech of recent felling, containing 35 to 40 per cent. of sap water. Two pieces, each $27\frac{1}{2}$ in. long, were taken from it; after having tarred the first, it was buried in the ballast, leaving the upper face uncovered, exposed to the air, and the other piece, not tarred, was preserved as a witness, exposed to the air but not

*When the natural beech wood (not creosoted) becomes spotted it loses its clear yellow color and passes to straw yellow or citron yellow, and its fibrous texture disappears. It becomes spongy and in planing the shavings have no body and crumble away. It breaks with the least effort, "like a radish," that is to say, the fracture does not present drawn out fibers as are produced with sound wood; to use a local expression, it is "cooked." In this state, which is always the prelude of the red decay, the screw spikes no longer hold well in the tie, but turn without effort.

The yellow wood in question contains no trace of creosote, as the analysis of the shavings shows. However diluted the creosote may be, the traces are easily observed, even in wood very lightly tinted, or by compressing the wood in a press between two leaves of white blotting paper, or better, by treating it with benzine.

Both yellow wood and "cooked" wood are stages of decay.

buried. At the end of six months the first piece was unburied, and it was observed while cutting it that it was heated and entirely spotted in the interior, but particularly under the uncovered face exposed to the sun, where the decomposition was remarkably much more advanced. The proof piece remained perfectly sound, and was dry; the other, on the contrary, had kept all of its moisture. That is what takes place in ties whose injection is only superficial.

In order to make the creosote penetrate better into that part of the tie which receives the screw spikes, the cutting and the boring are performed before injection, and this practice has been followed in France, in a general way, since 1894.

By comparing, by means of longitudinal sections and samples, previously taken from different points of their length, the ties injected after this procedure with those injected without holes, it is observed that the first are impregnated with creosote under the mortise and in the region of the holes; but the second are injected only at a distance from the extremities, which varies with the degree of humidity of the ties at the moment of injection, which often does not reach the mortise. And as the creosoted wood is not reached by decay, and as a single fiber of injected wood remains unimpaired in a center of decomposition, we are assured that boring the ties before injection increases their durability, and that it is a good practice.

Independently of the experiments related above, Mr. Ferry has made others on thousands of ties, developing the same facts. We will cite only one to show the influence of creosoting to refusal.

Of 1,152 beech ties, injected after this manner, and placed in 1877 on the line from Mouchard to Bourg, between kilometers 492,024 and 493,000, all were as sound in 1896, that is to say, 19 years after placing them, as on the first day, while 1,204 ties placed in 1889 on the same line, which were only injected with $37\frac{1}{2}$ lbs. per tie, were entirely decayed, in the proportion of 35 per cent., at the end of six years.

The conclusion to be drawn from these experiments is that ties are generally creosoted very superficially, for the reason that it is not possible to obtain a complete drying for the extraction of all the water which they contain. Even by stove drying, the operation cannot be pushed sufficiently far to remove all the sap; we must therefore be contented with allowing the ties to dry naturally, which always shuts up a certain quantity of water, particularly in their center.

Injection practiced after an imperfect drying has also the effect

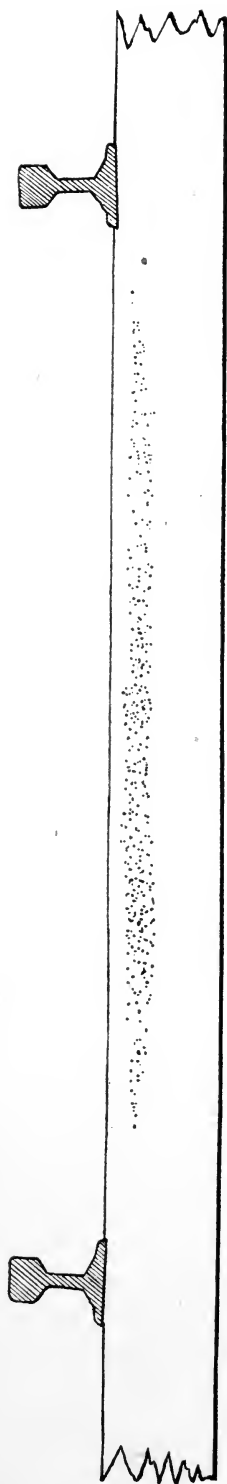

Fig. 27.

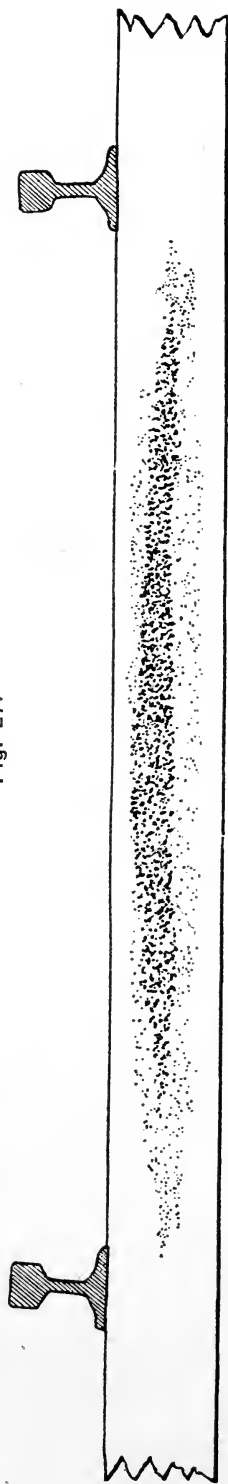

Fig. 28.

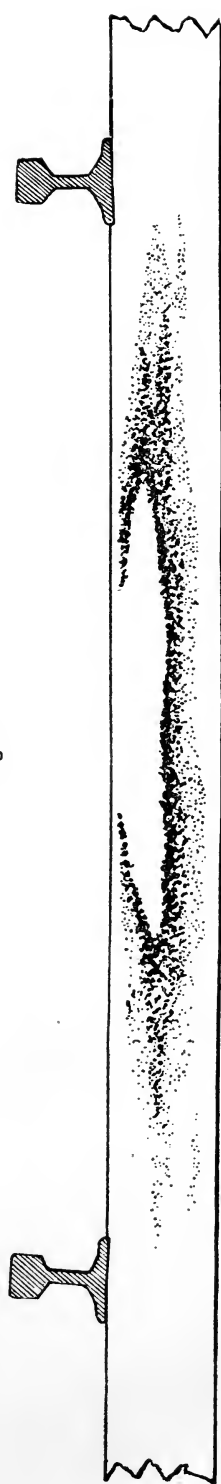

Fig. 29.

of concentrating the water in that part, which becomes consequently a center of decomposition for the tie. Each tie then commences to decay in its center, which is the part exposed to the alternatives of heat and dryness, while the extremities, better creosoted and under protection of the ballast, resist for a longer time.

TREATMENT OF PINE AND OAK.

The same process which has been found for beech is applicable for pine; the latter ought even to absorb a greater quantity of creosote. The same thing does not hold true with oak; the heart of the oak only takes traces of creosote, only the sap being penetrated by the injection. But this hard fiber is sometimes a disadvantage instead of an advantage; for if the heart of the oak is not dry (and it is hard to tell whether it is or not), the envelope of creosote prevents the slow evaporation of the sap, which finishes by being decomposed, and attacks in its depth the wood of most sound appearance. That is the cause of decay of the greatest number of ties, every piece of wood having more than 20 per cent. moisture, and covered over with a superficial bed, rapidly deteriorates, the beech at the end of three months, the oak at the end of a longer period.

The heart of the oak, which only absorbs a very small quantity of creosote because of its persistent state of moisture, is, however, susceptible of decay from a cause other than that of its superficial envelope preventing the slow and gradual evaporation of the sap. The wood is, in fact, generally very much cracked; under the action of atmospheric variations, these fissures open gradually wider and form a kind of trough, where the water enters vertically. At the end of a certain time this succession of moisture and of dryness favors the development of fungi, and produces work of decomposition in the wood, which always perishes in its central part, generally not covered over. It is worth while remembering that the simple bed of ballast placed on the breach of the tie, the plate placed under the rail, protects the wood in an efficient manner against this kind of decomposition. This evidently arises from the fact that, in the case of ties drying rapidly, like those of beech, the creosoting is more complete; but in the case of oak, which is only made superficially antiseptic, the fissures do not form as in the uncovered central part, and the decomposition of the wood is not produced.

The preparation of wood before injection, and the proper drying of it, are very important. The amount of the injection ought equally to enter into the computation, for if it is insufficient, it prolongs

but little the durability of the piece of wood. Results from actual experiment explain why, in spite of the expense which it induces, the amount of creosote used has tended constantly to be increased.*

In order to obtain satisfactory results, it was necessary to reach refusal; a point which is not absolute, and depends even upon the dimension of the piece submitted to injection. Thus, the beech ties, 8.86 ft. long and of ordinary dimensions, scarcely take 55 lbs., even to saturation; the pieces of more restricted dimensions, like the blocks of composite ties, absorb a greater quantity of creosote—20 per cent. more—because the water of sap is more completely eliminated. These pieces can then become indestructible and invariable in volume, as has been stated, whatever may be the agents to which they are submitted. The sap water having been replaced or surrounded by an antiseptic substance, the body is as though mummified, without undergoing any alteration in the future. This is what explains that, in spite of the variations in temperature, the blocks are maintained for nearly four years in the metallic skeletons without undergoing any modifications.

Experiments permit us to state these general points precisely; two pieces of beech were taken, one from a tree felled in the month of December, 1902, whose dimensions were: Length, 27½ in.; width, 9.8 in.; depth, 5.9 in., and they were placed under observation. When they had attained the degree of seasoning of 20 per cent., presenting then at their extremities important longitudinal clefts, they were submitted to two successive injections of creosote in such a manner that they absorbed the greatest possible quantity of it. The four faces of each of the blocks on three different sections were previously referenced to the tenth of a millimeter; they were referenced anew after the creosoting. The absorption of the creosote, at the rate of 18.7 lbs. per piece of wood, produced a mean elongation of each face of 0.04 in. and the fissures were completely closed. The void existing in a piece as dry as possible is then very small, scarcely 0.04 in. on each of its faces; it is the maximum play which can take place in the wood when it passes from the dry to the humid state, or inversely. But with an injection to refusal there is no play to fear, since the pores of the wood are filled up

*Amount of creosoting reported:

Oak.....	11 to 15.4 lbs. per cross tie. (Refusal.)	
	28.6 lbs.	The Northern Co.
	33 to 35 lbs.	The Western Co.
Beech.....	35 lbs.	The P. L. M. Co.
	52.8 lbs. (Refusal.)	The Eastern Co.
	26.4 "	The Midland Co.
Pine.....	30.8 "	The Orleans Co.
	26.4 "	The P. L. M. Co.

and can absorb no more, and since, on the other hand, the block protected by the metallic skeleton will not give up any part of the liquid absorbed.

I treated, like the beech, four blocks of heart oak; these pieces of wood did not absorb any appreciable weight of creosote, scarcely 0.44 lbs. each; that is to say, a quantity scarcely sufficient to coat them superficially.

Finally the wood, dried to an amount inferior to 20 per cent. by means of stove drying, for example, and replaced in air, regained moisture in a short time so as to reach the amount of 20 per cent. That which we will designate as dry wood will, then, be wood containing 20 per cent. of its weight of water.

INFLUENCE OF CREOSOTING ON THE RESISTANCE TO COMPRESSION.

But if creosoting has given favorable results from the point of view of the preservation of the wood, it acts, on the contrary, in an injurious way, to diminish the resistance of the piece submitted to compression. Mr. Ferry has made a series of very interesting experiments on the resistance to compression of pieces of wood submitted or not to an injection of creosote, and placed either in the direction of the fibers or perpendicular to that direction. An apparatus constructed by Mr. Collet was employed to produce this compression, and which permitted a pressure of 8.8 net tons to be reached; the wood was experimented with under the form of cubes of $2\frac{3}{4}$ in. each way. The results of the experiments are summarized in the table below:

	Load, lbs. per sq. in.	Deformation when load is applied perpendicular to the fibers		Deformation of wood on end.
		Following the Medullary rays.	Perpendic- ular to those rays.	
Dry oak	1,741	0.00290 m.	0.00380 m.	0.00117 m.
Dry beech	1,741	0.00160 m.	0.00350 m.
Creosoted beech	1,741	0.00287 m.	0.00334 m.*	0.00105 m.
Spruce	508	0.00314 m.
Spruce	1,741	0.000875 m.

*Deformation obtained with 1,306 lbs. per sq. in.

These figures have not an absolute value, but a relative value, for it would be necessary, to obtain the former, to take account of the deformation of the apparatus itself, which has an influence on the results. What we should keep in mind, nevertheless, is that the deformation varies within sufficiently large limits, according to whether the force is exerted perpendicular to the fibers of the wood, to the medullary rays, or else in a perpendicular direction to those

rays; finally, according as it is produced on the wood on end. Spruce resisted the best, at least in the perpendicular direction. The deformation in this direction would be about once and a half greater than it is in the perpendicular direction, that is to say, following the medullary rays. The deformation is accentuated when the wood is injected by about double; the liquid injected exudes at the same time that the increase of pressure is produced. In every case the deformation of the piece of wood takes a particular form: the spring layers, which are the most tender, crush, and the autumn layers, which are the hardest, slide over the first, giving the aspect of a series of checks.

These phenomena are manifested when the wood is in a free state; it does not seem that it should be thus when the wood, submitted to compression following the medullary rays, is prevented from being deformed, whether it be shut up in a skeleton which sustains it, or whether it be maintained in the transverse direction by a counter pressure. In this case it acquires a superior resistance and does not allow itself to be easily deformed because it is sustained.

That is what I have observed on composite ties by comparison with ordinary ties. It is recalled that the blocks of the composite tie are pressed between the walls of the skeleton by means of cross bars, and that the skeleton is thus shut up on these pieces of wood in order to compress them. It is thus possible to appreciate the influence of the compression of the wood in default of direct experiments.

CHAPTER VIII.

METHODS FOR REMEDYING TRACK DEFORMATION.

After having studied the principal deformations to which the track is submitted, it is proper to summarize the causes which have produced them and to search for methods to remedy them.

We have seen that the deformations consist of the creeping of the track, the reduction in gage of the track, or its spreading, the compression of the supports, the extraction of the screw spikes, which contributes to the vertical deformation of the rails, and finally of the shock, which is produced right at the joint, and which renders the latter the worst point in the track. We have set aside in this enumeration, which is not necessarily complete, the sliding of the track, which is exercised in a peculiar manner, and has no relation with the deformations in question. The latter, as also those we have pointed out, are due to two principal causes: the flexure of the tie and the longitudinal movement of the track, this last movement being itself a function of the flexure. Recapitulating, it is, therefore, the reduction of the effect of these two causes to which all specialists should bend their efforts. But, before examining in detail the proper means for diminishing the importance of this effect, it is necessary to give an account of the manner in which the tie rests on the ballast, because its position in the ballast ought to fix the tamped bed which should be made, and the length to give to it.

It follows from numerous statements which we have worked out that the tie, however well tamped it may be, and of whatever length, gives, at the end of a certain time after the passage of trains, the same form of flexure to the ballast which it experiences (see Figs. 30, 31 and 32). This flexure we have made known above; it is either, if the tie is long (more than 7.54 ft.), a concave curve with light swelling in the center, or else, if the tie is short (less than 6.88 ft.), a convex curve. This deformation of the ballast is not, as has been thought, an elastic deformation, but entirely per-

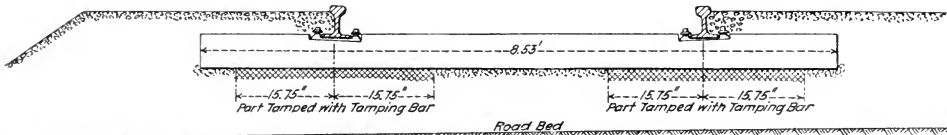

Note: The hatching indicates the parts of the bed for laying wedged by tamping with the rammer. The parts not hatched are simply filled with ballast not compressed with the rammer.

Wood Tie Normally Tamped. (Track without elevation)
Arrangement of tamping when it has just been done and before the passage of train.

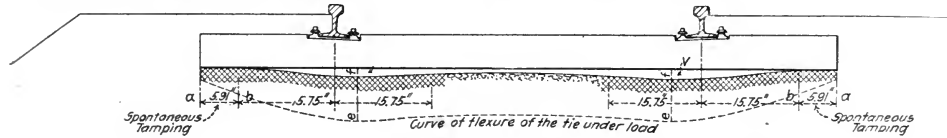

Wood Tie Normally Tamped. (Track without elevation)
Arrangement of tamping after a traffic of 500 trains.

Note: The parts a b become spontaneously wedged a short time after laying. The dotted line is the curve of maximum flexure under load.

There exists in repose, between the lower face of the tie and the bed for laying in ballast, a space V in the form of a basin on which is moulded at the moment of loading the face of this tie, which continues to descend even to the dotted line. This space varies from $\frac{1}{4}$ of a millimeter to 1 mm according to the nature of the ballast. The flexure under the load E is an average of 2 mm for the R.M. track laid at L+4.

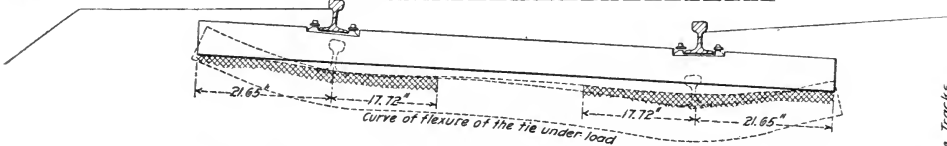

Wood Tie Normally Tamped (Track with elevation of 3.27" Radius 1968.5 ft.)

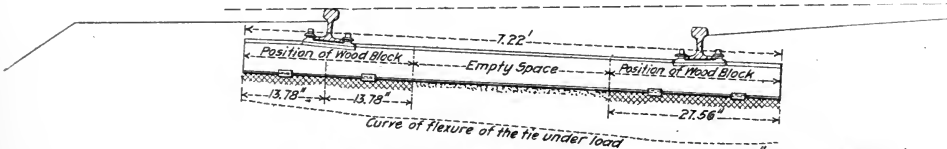

Composite Tie Normally Tamped. (Track with elevation of 3.27" Radius 1968.5 ft.)
Arrangement of tamping after a traffic of 500 trains.

Note: The composite tie is only tamped under the block extending for 13.78" on each side of the rail. The rest is empty. The tamping with the tamping bar from the beginning does not become modified with time, and no void is observed beneath the tie in repose, as takes place in the case of the wood tie.

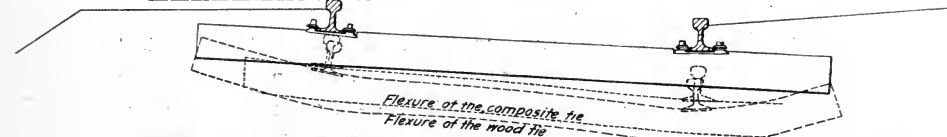

Comparative Flexure under Load of the Composite and Wood Ties. Track with elevation of 3.27" Radius 1968.5 ft.)

Figs. 30, 31 and 32.

manent, which remains when the cause which produced it has ceased.

The ballast, in spite of all contrary appearances, is not elastic; it subsides successively and little by little under the passage of vehicles. This subsidence is variable according to the nature of the ballast and the state of the subsoil, and amounts to 1.18 or 1.57 in. when it is a question of gravel and a subgrade capable of deformation (embankment and cut argillaceous), and some millimeters only, when the ballast is composed of broken stone, and when the subgrade resists more completely. Thus it would seem that the track ought to descend, and by appreciable quantities; it is not so, happily, and at the end of a certain time a sort of equilibrium is produced; the tie becomes suspended above the ballast when it is not submitted to any load; it reposes on its extremities, whatever may be the care used in the tamping, and inflects in the void existing between the upper part of the ballast and its lower face, a void which arises from the subsidence of the support under the load. This observation, which I have made many times, and which is of great importance, as we shall see further along, has likewise been registered by Mr. Couard (paper of July, 1897, on the vertical deformation of rails). One reads, in fact, on page 36 of this interesting article, the following conclusion of the causes of the vertical deformation of rails. "It is necessary to conclude that the ties fixed to the rail rest on certain points suspended above the ballast, and that right at the rail there are formed under the ties, even the best tamped, depressions in the ballast, on the edges of which the tie is supported; under the passage of a wheel even lightly loaded, the ties make contact with the ballast and inflect to the bottom of the depressions; from this moment only the increase of the bending is proportional to the load."

POSITION OF THE TIE IN THE TRACK.

The tie thus takes an appreciable flexure, which produces the dislocation of the joint and the deformation of the rail, and this flexure is due, in the ordinary case, to its excessive length, and to the unequal distribution of the pressure on the ballast, which is a consequence of it. The elasticity, which it is believed should be attributed to the ballast, and which is so construed from the fact that the tie returns nearly to the place which it occupied before the passage of the load, depends upon the bent tie itself and on the reaction of the roadbed. It is possible that the tie does not always rest on its extremities, but that it is supported on its central

part, which is the case with center bound ties; that is to say with those which oscillate about their center, and which render the track unstable; this is produced when the tie meets a resistance at its center superior to that at its extremities, which is due either to the inequalities in the roadbed, or to the shocks arising from the vertical deformation of the rails, which unwedge the tie and remove the extremities from support.

The way ballast behaves under pressure leads to consequences which should be fully understood, and which explain the poor stability of certain tracks. Long ties have often been preferred because they could be shifted endwise and re-employed after adzing; that is a very bad practice, which it is necessary to abandon definitely. The ties rest, as has been seen, on their extremities; the longest by reason of their flexure on the one hand, and by the unequal distribution of the load on the ballast on the other are situated at a higher level than that of the shorter ties, when, after the passage of vehicles, they have returned to their initial position. For the compression of ballast is as much greater as the point considered is brought nearer to the point of application of the load, in the particular case of the rail. This explains why ties of unequal length succeeding each other in the track are of different heights, and produce a track in the form of a mountain, with high points and low points. The track becomes jolty; the rails present inequalities prejudicial to their good stability, and that effect is the more sensible the greater the speed.

But the same principle does not hold with ties of different cross sections. Under the load they descend unequally in the track, but these inequalities should be restricted in comparison with the first, because the longitudinal deformation of the tie is greater than its sinking. From a long tie resting suspended on its extremities, it follows that, in the experiments which we have made, the wood ties ought to be found, after the passage of a certain number of trains, at a higher level than that of the composite ties. This circumstance, which is perfectly explained, has nothing mischievous in it, since the whole track is displaced parallel to itself. But inequalities may occur at the passage from the composite ties to the ordinary ties.

EFFECT OF CLIMATIC VARIATIONS ON THE TIE.

The fact that the ties rest on the end, as has been proved, is also confirmed by the manner in which they behave on a very wet subsoil, or, on the contrary, on a very dry support. When the road-

bed is argillaceous, it is known that it rapidly becomes muddy; the water is arrested on its surface and rises, especially in the central part, with the mud which it induces. The ballast becomes dirty, and the tie pumps because it rests on a muddy bed, which has, little by little, replaced the ballast buried in the roadbed. One of the methods for arresting this movement and this pumping consists in the establishment of walls at the extremities of the ties; the central part of the track is thus consolidated, the water remains in its interior, but the tie no longer pumps, because it is carried on a firmer soil, and because it no longer has the tendency to be supported on the less solid part, in consequence of its greater flexure. This method amounts to diminishing its length by increasing the points of support.

In the same way, when the variations of temperature are produced, the loaded tie modifies of itself its bed. When the ballast and the roadbed are very wet it spreads and assumes a longer bed; on the contrary, when the support becomes dry, the tie rises, so to speak, above its original axis. It takes a smaller bed, inferior to that which its length would permit.

This arises from the manner in which the load is distributed over a given surface, and the fact pointed out is the particular explanation of a more general law. The zone of influence of a load is of much greater extent, as the surface submitted to that influence is more capable of deformation. It is, consequently, of small extent when the support is rigid, and extends further when the latter is flexible. The disadvantage of these variations, for the subject which now occupies us, is that the flexure of ties increases with the deformation of the support; in order to do well it would then be necessary to eliminate the hygrometric and spongy ballast, and consolidate the roadbeds susceptible of notable deformation.

Recapitulating, it can be said that the tie, such as actually exists, is an elastic material resting on a support subject to deformation (the ballast), very little elastic (the roadbed). Its slight rigidity causes it not to rest on its whole length, and to distribute unequally the pressure on its support, the parts nearest to the load being submitted to a severer compression, that is to say, to a greater deformation. This deformation subsists by reason of the feeble elasticity of the roadbed, and at the end of a short time the tie rests on its extremities; it is a well understood question of a tie well tamped at the moment of laying, and established upon a roadbed of uniform resistance.

TAMPING.

Here naturally arises the problem of tamping the tie; on that question engineers are divided, because they have not perhaps analyzed in a sufficient manner the given data of the problem. How many times have I heard asked of the heads of sections the length which they desired, in order to make the track solid? And how many different replies have I heard, to the effect that the problem appeared unsolvable, so that each section foreman was allowed to make his own rules!

As a matter of fact, this does not make any trouble under actual condition; all the tamped beds, whatever they be, lead to the same result; the tie always rests on its extremities. It is necessary, however, to guard against a tamped bed over the whole length of the tie, because it might cause its unwedging and make it center bound.

But the actual situation can be remedied, and in a general manner; it is not necessary to seek the length of the tamped bed for a tie whatever it be, that is to say the length of its bed intended to distribute the pressure as uniformly as possible over the ballast, and to prevent consequently its deformation, but—what is quite a different matter—the length of the tie should be studied, in order that it may undergo the least flexure. The first problem, such as is proposed, is unsolvable; the second, we have seen, offers a very clear and very precise solution. The length of the tie of least flexure being determined by experiment, nothing is more simple than to ascertain the best length for the tamped bed. Thus it has been found that the tie ought to have a length between 7.05 ft. and 7.22 ft.; the tamped bed will have a total length equal to twice the breach of the tie. The whole is symmetrical in comparison with the load, and consequently the pressure will be distributed nearly uniformly over the support. It would be mischievous to extend the tamped bed on the side of the center, because the tie would be deformed in an unequal manner, as we have seen.

LENGTH OF TIE OF LEAST FLEXURE.

An objection can be put forth against the shortening of the tie on account of the obligation to avoid the cracks which are produced at the extremities in consequence of the introduction of the screw spikes. This useless length, it has been said, is a necessary evil; I do not think so, for, if the theory of the tie of least flexure is admitted as exact, nothing prevents consolidating the extremities

with a special shoe, or a screw spike, as is done by certain French companies, the Eastern, for example.

But that is not all, and if it is desired to reduce the deformation to its minimum, which is necessary in order to allow an increase of speed, it is also necessary to have recourse to the measure extolled since 1897 by Mr. Couïard. That is to say, it is necessary to give to the tie the highest possible moment of resistance; that of the wood tie, brought to the standard of the steel, is only 36, while that of the composite tie reaches 87, and is never less than 60.

The experiments which we have made naturally condemn all steel ties in the form of a trough; for, on the one hand, their resisting moment, less than that of the wood ties, is too weak, and on the other hand, the tamped bed is almost impossible to make, even with reduced dimensions which would lead to a less deformation. The moment of resistance could only be increased in two ways, and neither is practically capable of realization; it would be necessary either to increase the thickness of the metal, and then the tie, already too costly, would have a prohibitive price, or else it would be necessary to increase its depth, and the inconvenience of a bad tamped bed would be still more noticeable. Ties in the form of a trough should, therefore, be abandoned, and their general use would be an error, which would be regretted in the future. I am not referring to the reduction in gage of the track produced in consequence of the permanent flexure by the tie, nor of the fastenings, which certainly constitute a weak point, but confine myself simply to the defect of rigidity of this type, and to the difficulty of tamping.

The reduction of the flexure of ties is actually a necessity; it will correspond also to a reduction in the longitudinal movement, and will diminish the deformations which we have pointed out. The study which I have made with composite ties compared with ordinary ties confirms this view. The transverse flexure is diminished at the same time as the longitudinal movement, which produces the disorganization of the splices. These facts do not require explanation; it is certain that the increase of the bending moment ought to lead to a less deformation of the track, and that experiment has confirmed what theory has presaged for a long time. It has also been possible to establish, thanks to the composite tie, that there was a length of tie of which the deformation was minimum, and that the more general problem of the zone of influence of a load resting across a support on a material capable of deformation has been set forth.

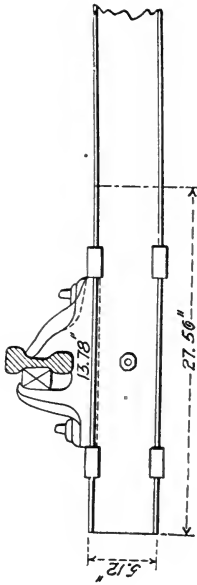

Track with Double Head.

Fig. 34.

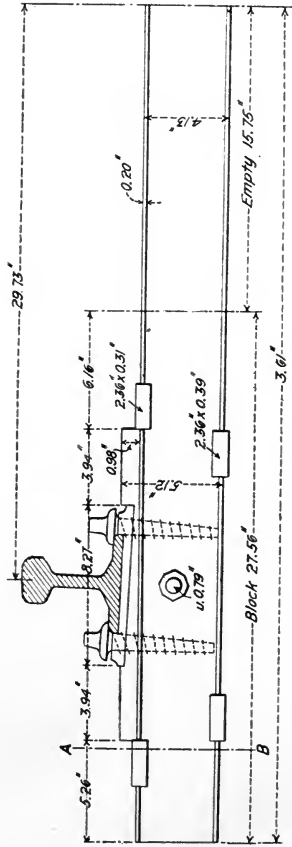

Half Elevation (U Iron)

Composite Tie. Michel System.

Fig. 33.

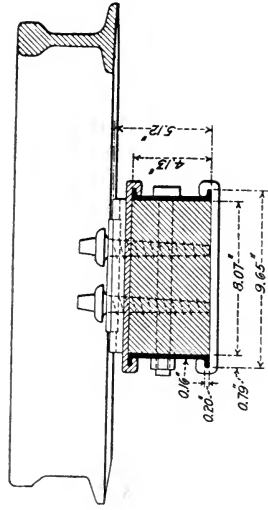

Section A-B.

Fig. 35.

COMPOSITE TIES.

The experimental composite tie, which has behaved in an absolutely satisfactory manner, is not perhaps the only model of this kind which could be conceived. Made with a metallic skeleton, which gives to it a great rigidity, which is to be desired, containing two wooden blocks, on which the fastening is made, and which distribute the pressure on the roadbed, it presents all the advantages which one could wish: rigidity and simplicity. No rivets, no bolts; the compression of the two materials is obtained by clamping the skeleton by means of metallic cross bars. It is true that the price of such a tie is high, and that it could not be commonly employed; on tracks of much traffic this objection would not have great value. The security of traffic, the economy of maintenance by the reduction of deformation remain to be put in the balance with a higher cost price.

But one of the inventors, Mr. Michel, understood how well founded this objection could be for lines of less frequent traffic, and has designed another type of tie, constituted with the same materials, wood and steel, but formed of more simple elements. The metallic parts are formed of two pieces of channel iron, containing between them two wooden blocks in the form of a parallelepiped. The assemblage is made by means of four cross bars per block. The new model allows the realization of a series of types of resistance, diverse and, consequently, of variable price, according to the resistance. (Figs. 33, 34 and 35.)

The tie thus made presents the same advantages as the first one experimented with, rigidity and facility for compactness of the attachment, but it does not rest absolutely on the same principles. The squeezing was obtained, at least in the first conception of the inventors, by the rising of the wedge; in this case, on the contrary, it becomes perfect, as soon as the beam is formed, because the cross bars make the elements, wood and steel, which compose it, act jointly. This tie is not open to the charge that it has the grave defect of comprising a great number of pieces, for it is an armored beam, which only exists after the assemblage is effectuated. It would be possible to make the same criticism of an armored cement beam, or, indeed, even against a compound beam; both are created only when their elements are reunited. The tie in question is definitely an armored wooden beam.

The assemblage can be made with the perfection and solidity which it is proposed to have for it, as was shown in experiments

undertaken at the laboratory of the Ecole des Ponts et Chaussées. The tie submitted to the test was composed of two pieces of channel iron, 5.51 in. deep, 0.20 in. thickness of web and 11.42 in. width of flange, bound together with cross bars of 2.36 in. by 3.94 in. Each of the oak blocks creosoted, at least superficially, was 27.56 in. long, 5.51 in. deep and 8.27 in. wide. The assemblage of the elements was made by placing the girdle constituted of channel iron against the wood, and by introducing the cross bars between the flanges of the channels by force. This procedure of squeezing was primitive, since it was arranged only by primitive means.

Nevertheless, it was sufficient, since the sliding of the piece of wood along the metallic body required a force of 8.8 net tons. The pressure obtained under the action of four clamps being 13.2 net tons, the coefficient of friction of wood against the iron was 0.3. The dislocation of such a beam is therefore not to be feared, and it is well to remark that under a similar force the wood tie would be either broken or near breaking, and that the steel tie would be on the point of bending (flexure of 0.91 in.).

But the assemblage can be assured by a methodical and even pressure, and the above limit may be exceeded, if necessary. The pieces to be united will be placed under a press and the heated cross bars will be introduced between the flanges of the channels; there will thus be realized, if it is desired, a total pressure of 39.6 net tons, which supposes a tension of 9.9 net tons per cross bar. Each of them having a section of 0.93 sq. in. would not be stressed to more than 21,334 lbs. per sq. in., which is acceptable. As to the wood, it would only be stressed to 526 lbs. per sq. in., about one-tenth of the breaking load.

It may be asked if the pressure, being obtained, will be maintained in spite of the effects of variations of temperature. I cannot cite experiments with figures for support; however, I will cite the first ties, which, placed in the track for four years, and submitted in consequence to all the temperature changes, have behaved well with a total pressure less than that which has since been realized. No yielding has been produced, and the central wedge could never be raised, except for a few millimeters. The proof has then been made experimentally that yielding is not possible under the conditions of test; but I do not wish to limit myself to this demonstration, and I am having executed at this moment a set of experiments relative to the effect of temperature variations on the clamping of beams made like the ties.

There is another point which I am having studied at the same time, and which deserves special mention. It is the hardening of the material by the effect of compression, a hardening which will diminish the sinking of the rail in its support, and consequently the deformation of the track and the stress on the fastenings. It is a general law; the compression of the material gives a resistance to it which it has not in a natural state. Mr. Considère, in a note inserted in the *Annales des Ponts et Chaussées* (second quarter of 1904), has shown that the resistance of cement was increased in the proportion of 1 to 6. The same fact should exist with wood; it is fitting to establish it, and to show every advantage which can be derived from it. It is probable that, thanks to this hardening, the fastenings will present a greater resistance and that they can be submitted to greater forces.

The best wood, whether for ordinary ties or of blocks for composite ties, is heart oak. It is not necessary to creosote it; it is sufficient to use a coat of tar and lime to protect its upper face from the action of inclement weather. The experiment made on the tracks on the line from Mouchard to Bourg produced excellent results; it demonstrated that this treatment was successful in maintaining ties which would have been rejected with brief delay without the preservative. The latter does not prevent, at the end or on the sides, the slow and progressive seasoning of the tie.

The tie may also be seasoned by floating it for five or six months to eliminate elements of decay, but this process is long, and not very practicable because of the long drying subsequently required. If the oak contains sap, which is unfortunately very common, the floating can serve to preserve the beam; but creosoting is a disadvantage rather than an advantage. The sap alone absorbs the creosote in a sensible manner, and after the injection forms an impenetrable envelope, under the protection of which the sap, not being able to evaporate, enters into fermentation and attacks the wood. It is undoubtedly better not to creosote sap oak.

The same thing does not hold true for pine, spruce or beech. These woods season rapidly and are capable of absorbing a quantity of creosote sufficient to render antiseptic the small amount of sap which still remains after seasoning (about 20 per cent.). But it is necessary to creosote to refusal, which requires the employment of at least 55 lbs. of antiseptic liquid for a tie of 8.53 ft.; under these conditions the sap is, so to speak, surrounded by creosote, and any fermentation is impossible. With a smaller dose, the sap

not being given immunity, enters into fermentation, and decay commences; this has been observed when the amount of creosote is reduced to 35½ lbs.

Besides these methods of preservation of ties, attention should be directed to the covering of their upper part by ballast, the employment of plates which protect the seat of the fastenings, and consequently the fastenings themselves. Perhaps it would be well, in the case of secondary companies, where the ties often perish by the fastenings and the decay of their sockets, to place in default of a plate, a hoop-iron shim, whose only purpose would be to cover the seat of the fastenings. On the P. L. M., notably, where a plate is employed, the decay of ties is scarcely produced, except in the central part. The fastenings are still good, except when they have undergone excessive turning, and then the tie ought to be rejected. This is not true on lines where the rail rests directly on the tie, and where the fastenings are absolutely uncovered; rust attacks the screw spike and the wood which surrounds it. The fastening becomes bad before the tie has become unfit for usage. From that arises the necessity for having recourse to a method for consolidation of the fastenings, which is not generally necessary on tracks provided with plates. It is the same in the case of the ties laid with even joints, for those of the following end, notably, often perish at their fastenings by reason of the hammering which they support at the joint. The wood in which the screw spike is engaged is torn, and the piece should be rejected. It holds that at the end of a certain time this piece is left in the air; the fastenings support the weight of the beam and finish by tearing the wood

METHODS OF IMPROVING THE JOINT.

The obligation of obtaining a more rigid track, in view of realizing greater speeds, and also of reducing expenses of operation, is in contradiction to the well-known principle that a railroad track should be elastic, and should not present hard spots. It is necessary, in discussing this question, to define the word "elasticity," as employed in this case. Is an elastic track that which, under the effect of loads, returns each time to its original position? Or should elasticity be understood as a special quality, difficult to define, which produces smooth rolling; should the track be like a spring of great power, slowly registering the shocks and diminishing the effect so disastrous for vehicles and for travelers?

If the first sense is adopted, an elastic track is necessarily a bad track; it does not diminish the shocks, it multiplies them. For

it is impossible that this elasticity should be at all points of like proportions; here the track, under the effect of the ballast, of the roadbed, and other causes, will be deformed more than at the neighboring point. Shocks and jolts, impossible to avoid, will result from it. Under existing conditions, with ties as they are laid, having small rigidity, it may be said that on each rail length there is first a drop, extending to the middle of the section; then a rise, from this point to the end of the rail. Both in the drop and in the rise there are high points and low points, which exaggerate the general bad effect. This is occasioned by the fact that the joint, in consequence of the drawing together of the ties at the splicing, which stiffens the rail, is the least elastic point of the track, and that in reality a hard point has been obtained when the contrary result was sought.

For, up to the present time, if we have used a suspended joint, it is because we have been afraid of having a hard point in its place; it has been surmised, wrongfully, that the supported joint was bad, and that it was necessary to keep it in the air in order to preserve that elasticity, which is only a deception. A track absolutely rigid as a marble table would be infinitely preferable for rolling to a track capable of deformation, like that which we actually have. This deformation—for the word “elasticity” is improper—is a necessity; it cannot be made otherwise, but it is not an advantage, any more than one could pretend that the elasticity of the bridge of Saints-Pères was sought for, and constitutes progress.

It has been forgotten that, on a track as actually constructed, hard points were not possible, because all the points of this track become deformed, and because, under the ties, the vertical displacement is greater than anywhere else. Mr. Couïard has shown that the flexure of rail between two consecutive ties was comprised between one-tenth and one-twentieth of a millimeter, and that the lowering of a tie under a load can reach four millimeters (0.16 in.); the mean is two millimeters (0.08 in.), that is to say the flexure of the rail is comprised between $1/200$ and $1/400$ of the lowering of the tie, and can be considered as infinitely small in comparison with the latter. Otherwise put, the tie bends infinitely more than any other point of the track; it is therefore wrong to think that it can constitute a hard point.

The necessity for laying rails in short lengths, in order to leave play between them for expansion, should not allow this fact to be lost sight of, that the extremity of a rail is like any other point,

and that it should not be otherwise treated. Now the two extremities of the rails which follow each other have a marked tendency to vibrate differently; and from this tendency a fall is created, which goes on increasing with time.

Not only is the splicing displaced, but the rail is curved under the effect of the fall and of the shock which follows. Mr. Couïard has shown that the unequal level, between the middle of the rail and its extremities, can attain 0.8 in., divided thus:

Permanent bending between the middle and the extremity of the rail.	.056 in.
Variable flexure	0.12 "
Compression of the ballast and of the subsoil.....	0.12 "
Total	0.80 in.

This material inequality is due to the fall and to the shock, that is to say, to the suspended joint; it is the direct consequence of it. When laying rails an allowance of 0.02 in. at the extremities is admitted; if this allowance is in a contrary direction at the two extremities of adjacent rails, it is possible for the total drop to amount to 0.04 in. This circumstance, which is frequently presented, is the cause for the permanent bending, which rises even to 0.56 in. The hammering of the rail at its extremities aggravates the original situation up to the limit indicated. It is the same as far as the variable flexure is concerned; an end of rail of about 11.81 in., since the ties of the even joint are spaced about 23.62 in., should not bend under the loads to which it is submitted by more than one-tenth of a millimeter. The variable bending which it takes, and which is 0.12 in., is solely due to the shock, and, consequently, to the suspended joint. It is possible then to reduce in an appreciable manner the unequal level of 0.67 in. by holding the joint and preventing it from vibrating. We will then have only the flexure of the tie, the compression of the roadbed, which can be reduced to 0.06 in. That is to say, by sustaining the joint the unequal level which is actually produced can be reduced to one-twelfth of its real value. This will not only make better track, since the shock will be lessened, but it will prolong the life of the rail, occasioning a material economy in renewals.

The disorganization of the splicing, which is the first effect of the play allowed at the extremities of the rails, their curvature and the shock which follows, can be avoided by fixing the ends on a very rigid tie. It is conceivable that the two extremities, fastened on a single piece, would act jointly with that piece, and would not have the tendency to work separately, as actually takes place. It is naturally necessary that the tie be rigid in order to avoid

the stress on the fastenings, but, under that reservation, the method which we have outlined, and which is very old, only presents advantages.

Mr. Couïard, in his study on the vertical deformation of rails, makes the following comment:

"The principal attempts which have been made at reinforcing the splices of rails and the want of success of the oldest attempts, leaves little to be hoped for from the new, and I do not believe that it will be in this direction that the solution of the stability of the joint will be found.

"Experience proves that it is dangerous to suppress the allowance for expansion in railroad tracks.

"The unsymmetrical placing of ties in such a way that there is a greater number under the first half of the rail, appears to have given good results on the line from Saint-Etienne to Lyons, the busiest of the P. L. M. system.

"The reinforcement of the joint, by drawing together the ties of the even joint, has been well tried; several companies have also sought to bring the ties of the even joint still nearer together, in connection with the suspended joint."

This tendency to draw nearer and nearer together the ties of the even joint leads to the adoption of the supported joint; it is therefore not astonishing to find in the discussion at the Congress of 1895 at London the following declaration by Mr. John M. Toucey, of the New York Central:

"We have no more suspended joints since we tried them some years ago. We abandoned them because the inflection was too great. The joint is supported by three ties: one in the middle, the others at the extremities of the splices.

"With the rails of 100 lbs. per yard and this splice bearing on three ties, there is scarcely any sensible inflection at the joint. The rolling is almost as smooth in the middle of the rail as at the extremities. We believe, therefore, that our system of splicing is the best."

I concur in this rational conclusion. Mr. Couïard also recognizes that this is good practice, and he has shown that if the supported joint has been rated as bad, it is because the tie at the joint, induced successively by the rail in advance and by the following-rail, oscillated and easily became untamped when adjacent ties were $31\frac{1}{2}$ in. away. He has established, in fact, that in the tunnels of Blaisy-Bas and of Saint-Irénée, with spacing reduced to 23.62 in.,

and with 87-lb. rails, the supported joints behaved well, although the pivoting of the ties still existed.

I conclude, then, that the only practical method for improving the joint is to support it on a tie and to place two others 11.81 in. from it. Moreover, untamping will be much less to be feared if a rigid type of tie is adopted, which always rests on its appointed bed. Experiment will alone permit of pronouncing upon this subject; but it can be said that untamping will then be less easy, because the tie, resting on nearly a plane surface, will distribute the pressure on the ballast uniformly, while actually, by reason of the flexure, the pressure is distributed unequally, and the ballast deformed unequally, which produces unwedging.

But this measure will only be useful after we succeed in correcting the unevenness which exists between the two extremities of the rail, and which proceeds, on the one hand, from defects in manufacture, and, on the other, from defects in laying. It is understood that if the joint still presents, after establishment of the track, any unevenness, in whatever direction, the latter will become rapidly worse, the tie of the joint becoming unwedged and finishing by churning, which is actually the case with the even joint. The unevenness will increase, and the state of things will become just what it is now. The first measure to be taken consists, then, in suppressing the existing unevenness; it is possible to accomplish this in two ways, either by placing wedges under the lowest part of the rail (but this would be difficult, for it is a question of some tenths of millimeters), or by planing the two extremities of the rail with a portable tool, which seems easy, in order to place the rolling surface at the same level on both sides of the joint.

Consolidation of the fastenings is indispensable to complete the good support of the joint. If it is indispensable to improve the joint, which is certainly the weakest point in the track, it is no less necessary to pay attention to the holding power of the fastenings. It has been seen how important they were, as much from the point of view of assuring the joint action between the rail and the tie as of the resistance opposed to lateral movement.

As far as concerns this resistance, it is proper to utilize the whole surface of the head of the screw spike, and, on that account, to adopt the tie plates, which diminish the effect of the cutting which the rail exercises on the body of the screw spike. Certain railroad companies, fearing this cutting, have kept its shank away from the edge of the base of the rail; this is a bad solution, for, if it serves to avoid one difficulty, it brings about another equally

serious. Lateral displacement of the rail, since it is not well supported and its overturning on curves, or sliding, is not properly guarded against. Experiments made on the P. L. M. on this subject show that with a metallic plate the cutting is very much diminished; it is true that we must take care of the abnormal wear which is necessarily produced between two metallic surfaces, the lower part of the base and the upper surface of the plate. But it is possible to interpose between the two surfaces a plate of felt or poplar.

On this account the reinforcement of the plates actually in use on the P. L. M. was occasioned; it has been seen, in the first part of this study, that, for want of a suitable reinforcement, the screw spike is not sufficiently sustained, and that under the influence of a relatively weak push exercised on the rail, it has a tendency to be overturned, not being stopped by the plate. The reinforcement, which we have made practical, has, on the contrary, arrested the movement of overturning and diminished the chances for inclination of the rail, and, consequently, of the spreading of the track. One can object, and it is probably the reason for maintenance of the actual type, that the reinforcement of the plate can induce loosening from the base of the rail, the head of the screw spike continuing to be supported on the reinforced part of the plate, while no longer being applied to the base. It does not seem impossible to remedy this disadvantage; it suffices, in fact, to slide an iron wedge under the head of the screw spike, in the same manner that wedges are placed between the splice and the lower part of the head of the rail. The importance of the result to be obtained justifies the measure which should be taken.

EMPLOYMENT OF THE TREENAIL.

As a means of consolidation of the fastenings, above all of those which are used in ties already old, the treenail has been employed with success. The wooden treenail, Collet system, was at first put in service, then the metallic treenail, of which one of the best types is the one invented by Mr. Thiollier. We pointed out, in the first part of the study, the results which the Collet treenail gave. I think it proper to recall them in revision.

The resistance to excessive turning, which is an essential quality of the fastening is:

For pine without treenail.....	132 lbs.
For pine with treenail	176 "
For hardwood, oak or beech, without treenail.....	220 "
For hardwood, oak or beech, with treenail	242 "

The resistance to tearing out, which is about 11,023 lbs., in creosoted pine with the treenail, in place of 7,716 lbs., seems to decrease with time; for it decreases at the end of two years to 8,818 lbs., to a limit sensibly equal to that which the wood possesses in its natural state. That holds according to the manner even in which the treenail is made; the latter is, in fact, cut out of wood in the direction of the grain, and thoroughly creosoted. Now it is known that a piece of wood thus established is in bad condition for receiving spikes or screws; they both hold badly. The wood does not permit of penetration by a screw thread; this has been proved by experiment with the treenail. Thus, when the insertion is first made, the force of extraction is exercised on the treenail; at the end of a few months the combination of screw spike and treenail submitted to extraction acts otherwise, it is the screw spike which is withdrawn, under a force of about 7,716 lbs. It holds from this that the wood of the treenail has not received the imprint of the screw thread; it is simply compressed more or less strongly, which in the beginning assures the union of the two pieces. But at the end of a short time the effect of this compression diminishes, the wood shrinks little by little, the contact diminishes, and the force which is necessary for extracting the system diminishes.

The resistance to tearing out in new oak ties is about 13,228 lbs.; it is about 15,432 lbs. when the latter are provided with treenails. But there is equally produced a diminution of resistance with time, as much in the first case as in the second, and the reason for it is the same.

As far as the resistance to overturning is concerned, the employment of the treenail does not appear to increase it materially; it depends, above all, as has been seen, on the reinforcement of the plate.

The useful effect of the treenail is not, in fact, very great for opposing such a movement, because the upright wood of the treenail presents quite a weak resistance, scarcely the tenth of the resistance of the wood submitted to a force perpendicular with its fibers; because, under the influence of the force, the hole takes an oval shape, and because the wood crushes.

Another disadvantage in this method of consolidation of the fastenings arises from the fact that its employment requires the use of plates, in order to protect its upper surface. It is thus that the treenails of ties on tracks of the P. L. M. Co. are well preserved, because they are provided with a plate, but they shrink in the same ties without the plate, and a space between the treenail and

the wood of the tie is produced, rendering the fastening bad and very shaky. This fact explains why, with certain companies where the plate is not in use, the wooden treenail could not be employed. It is possible, we believe, to remedy this disadvantage by placing on the head of the treenail a protecting coat composed of tar and sand, or of lime, sufficiently elastic to lend itself to all the movements of the tie.

It may therefore be said that, under actual conditions, the treenail prolongs the durability of a tie whose fastenings are damaged, but it does not give an increase of resistance, since the latter diminishes quite rapidly. It is not safe, therefore, to count on its employment for improving the fastenings in a permanent manner; at the beginning an improvement is obtained, but it does not seem to continue.

THIOLLIER TREENAIL.

Against excessive turning, which it is important to avoid, there is not any increase of resistance; the employment of the Thiollier metallic treenail seems on the contrary to produce this increase. This treenail is nothing but a steel helix of oval section, of which the number of spirals varies according to the pitch of the screw spike, and which is incorporated right at each screw spike of the tie in a socket previously cut in the tie by means of a cutting tap. The lining has the same pitch as the screw spike to be employed, and an interior diameter about the same as that of the core of the screw spike, in order to reduce the play between the two pieces to the minimum; the helix, prepared for its normal service, is always flush with the upper part of the tie, lines the place cut out for the plate, and, at its lower part, ought always to rest on at least 0.39 in. of wood not tapped.

According to the inventor, as soon as the squeezing force commences, by the contact of the cap of the screw spike with the rail or the chair, the lining increases in diameter, embraces the forms of the screw spike, which places the latter under protection against all spontaneous untightening, and assumes the function of a spring, all the different spirals obeying the force parallel to its axis transmitted by the screw spike.

The lining, by its diameter greater than that of the screw, engages the parts of the wood with a more extended surface than that engaged by the threads of the screw spike, and in re-employed ties, where the same site is preserved for the screw spike, the parts of the wood less altered or less blackened.

These advantages have caused certain railroad companies to employ the Thiollier lining. The results of extraction are essentially the same as those which are obtained with the Collet treenail; that is to say, the resistance is increased by about 30 per cent. But experience has not perhaps been sufficient to enable us to pronounce on the efficiency of the lining after a certain time of employment; and it is to be feared that there will be produced, as with the Collet treenail, a certain relaxation of the distended fibers. In each case the resistance to excessive turning is limited. It does not increase constantly, as a purely superficial examination would tend to prove. It is necessary to guard against squeezing it too tightly, for the spiral and the screw spike are made like a nut and its bolt. In acting on the bolt, the nut is made to ascend; the spiral ascends, the rings come to be pressed against each other and against the plate, tearing the fibers of the tie, and the apparent resistance to excessive turning is as much greater as the fastening is more dislocated. But it is easy not to reach this limit, and it is easily possible to remedy this disadvantage by providing the treenail with a spur applied against the bottom of the tie, and by diminishing the flexibility of the spirals in order that they may not be able to be pressed against each other.

Nevertheless, the Thiollier lining is an excellent palliative, for it increases the resistance to transverse overturning comparatively with the known systems, and is economical, since the lining can be placed without withdrawing the tie from the track, which produces an economy of about 1 franc (19.4 cents).

Apart from the effect of overturning, which is very rarely produced, while admitting at the same time that it can take place, there is occasion for considering the resistance which the rail, provided with its plate and its fastenings, presents to sliding. It has been possible to verify this resistance by means of the Collet déclinètre, and by a special arrangement which permits of direct action on the plates. The results of these experiments are given below:

Five ties creosoted: With bare screw spikes.....	8,598 lbs.
With screw spikes and treenails	11,905 "
With screw spikes provided with Thiollier linings.....	15,212 "
New oak creosoted cross-ties with bare screw spikes.....	17,637 "
New beech creosoted ties	18,298 "

The following comparison can be made, so far as the forces for tearing out are concerned, according to whether the ties are or are not provided with treenails or spirals:

Five ties: With bare screw spikes	6,834 lbs.
With screw spikes and new treenails.....	10,824 "
With screw spikes and treenails after 3½ years' service....	8,818 "
With screw spikes and spirals.	9,148 "

It can be said, in recapitulation, that the Thiollier spiral presents 28 per cent. more resistance against sliding than the Collet treenail; the latter, on the contrary, offers 18 per cent. more resistance against tearing out than the spiral without interposition of the plate. In the case in point, it is therefore only a question of ties of soft wood, for with hard wood the resistance is more considerable, and the employment of the treenail or of the spiral is not pointed-out.

It is evidently possible to consolidate the fastenings of ties in bad condition by employing either the Collet treenail or the Thiollier lining, but is the result obtained definite, and ought one to count on a constant and notable improvement? I do not think so, at least with the Collet system, because this treenail is cut from wood parallel with the grain; I reserve my approval so far as concerns the Thiollier spiral, because experiment has not been carried on for a sufficiently long time. Will there not be, on the other hand, a certain advantage, in point of view of resistance, in placing such systems in a composite tie, where the wood is compressed between two metallic parts? This is probable, because the wood is maintained in constant tension against the fastening, without it being possible to produce withdrawal. From the same cause the sinking of the rail in the tie diminishes, which reduces the inclination of the track by its spreading, as well as the movement of the joint.

The employment of the treenail and of the spiral, such as they are known, certainly does not constitute the only method of prolonging the life of ties in bad condition. A simple plug of wood, cut perpendicular to the fibers, can fill the same office, especially if care is taken to give it the form of a truncated cone, whose large base should be directed downwards. When tightening the screw spike the plug would be caused to rise, and its intimate contact with the tie would be assured.

But, whatever may be the type adopted, it is necessary to protect the head of the plug against atmospheric variations; for that a simple coat of tar with lime will suffice, in the case where the plate will not be adopted.

The employment of a bolt to replace the screw spike, with the bolt resting on the lower surface of the tie, is perhaps no longer an always satisfactory solution, because a reduction of resistance to overturning is to be feared. Against tearing out, on the contrary, the resistance is maximum.

CHAPTER IX.

RECAPITULATION AND CONCLUSIONS.

In the first part of this study, I pointed out the principal deformations which track can undergo and which consist of: Creeping, the reduction of gage on tangents, or spreading of gage on curves, the compression of the tie at the supports, the tearing out of the screw spikes, the poor holding of the joint, which produces dislocation of the track and the vertical deformation of the rail.

I have shown that all these deformations, which when taken singly, have only a small influence, exercise, in the aggregate, a considerable effect, as much from the point of view of limiting traffic as from facility of maintenance, and that they prevent the increase of speed on all sections of lines where that increase is desirable. Two principal causes act to produce these deformations: the bending of the cross-tie and the longitudinal movement of the track.

Some eminent engineers, Mr. Couard notably, who has been the most careful and patient observer, have only imperfectly seen this relation of cause and effect; Mr. Couard concluded, after having summarized these observations in a series of articles in the *Revue des Chemins de Fer*, that there was occasion for increasing the moment of resistance of the tie, and substituting for the type actually in use a type with reinforced section much more rigid. This conclusion, set forth in 1897, was a logical one; it contradicted in some respects the interpretations of a group of engineers, notably represented by the Germans, who thought that the loaded cross-tie rested completely on its bed of ballast, and that consequently the pressure was transmitted integrally over this bed, here more, there less, according to the sinking of the ballast or the deformation of the cross-tie. I believe that I have shown experimentally the error in this theory. The non-loaded cross-tie placed under the best conditions of stability rests on its extremities; under the effect of the load, it is deformed and is moulded in the ballast. The ballast subsides little by little, and finally takes the form of the deformed

cross-tie. The subsoil reacts more or less according to its nature, and that is what gives to it the illusion of that elasticity, which has been freely ascribed to the ballast.

But the tie does not transmit to all points of its bed the pressure arising from the load which is applied to it. The zone of influence of the load is very limited, hardly reaching 13.75 to 15.75 in. from its point of application. There is in it a general law already noticed by Mr. Mesnager, Engineer of Bridges and Highways, in charge of the laboratory of the school, who has demonstrated that in connection with a reinforced concrete floor system of beams and slabs, the entire length of the slab should not enter into the computation so as to reduce the section of the beam, as the zone of influence of the load is limited. It follows that on a movable bed like the road-bed and ballast, the application of the load is made over a small length on each side of the rail; beyond that, not only is there no pressure, but a tendency to a sub-pressure. It is similar to the case of a substance of small resistance, like turf, where the load causes the soil around the loaded and displaced zone to rise up; here the phenomenon is clear, but in the foregoing it is less apparent.

It is not then necessary to extend a cross-tie beyond a certain limit, and that limit corresponds precisely with the length which gives the minimum deformation of the piece. With that length the maximum of useful effect and the uniform distribution of the load on the ballast will be obtained. This is an appreciable result. If the tamped bed be maintained as originally established, there will be no more such frequent unwedging.

The question of the length to be given to tamping will be solved at the same time. It has not been up to the present time, because the problem, as was stated, did not admit of solution. It has been sought to discover what is the length to be given to the tamped bed under a cross-tie of whatever length, having no relation, on the one hand, with the load, and, on the other, with the gage of the rails. All the solutions were equally good, or rather bad. The problem is indeterminate, because it does not admit of a single solution. It is necessary, as I have pointed out, to reverse the position of the problem and seek the length to be given to the cross-tie, in order that it shall experience the minimum of flexure. The limit to be given to the tamped bed corresponded with this minimum of flexure.

Neither has sufficient attention been paid to the manner in which the tamping should be done; some trackmen do it on the right, while others do it on the left. There is no uniformity in

their efforts, and the unequally tamped tie has a natural tendency to become unwedged. Mechanical tamping, which Mr. Albert Collet has rendered practicable, will give, we believe, excellent results, and its general use will be imposed, when it is desired to establish a very stable track always comparable with itself.

But this stability of the track will not yet be complete, if the joints are not redesigned, if we do not fix them firmly and avoid dislocation, which the best and most solid splicing only retards. All that has been attempted up to the present time is to render this splicing more rigid and to bridge it, so to speak, between the two cross-ties of the even joint. Some engineers have been logical; they have drawn the cross-ties of the even joint nearer together, and they have joined them as twins, but few have dared to go to the end, that is to say, to place the cross-tie under the joint in order to support it. They were afraid, doubtless, that they would be reproached for sacrificing elasticity, the vague term which comprehends everything, and for creating hard points. It is the contrary which is true; the hard point is found between two ties. Elasticity is given by the tie, by the sinking in the ballast and the roadbed. It is necessary then to approach the problem resolutely, as established by experience. It is necessary to support the joint by a rigid cross-tie, which will diminish the bending, and consequently the longitudinal movement, the cause of the dislocation of the splicing. It is necessary to draw together the two neighboring cross-ties, to reduce their separation from the joint cross-tie, to prevent the rocking movement which is necessarily produced by too great a spacing.

It remains to select the type of cross-tie corresponding to the general conditions which we have imposed. A rigid cross-tie is necessary, much more rigid than the actual wood cross-tie, which has a resisting moment of about 36, wherever it is desired to increase the speed. This necessity for reinforcing the cross-tie excludes, *ipso facto*, the steel cross-tie in the form of a trough, because its resisting moment can only be increased by adding to the thickness of the metal or to its depth. In the first case, a cross-tie too heavy would be beyond price; in the second case, being too deep, it would no longer be capable of being tamped.

It is possible, then, only to take the wood cross-tie with a stronger section, or else a composite cross-tie (wood and iron, cement and iron, etc.) of a type similar to that which has been experimented with. We can find fault with the high price of the skeleton of the latter, which, being constructed with a special iron,

will be expensive to manufacture. The inventors have themselves stated this disadvantage. Mr. H. Michel invented a new model of cross-tie as rigid as the first, but of a more practicable application, because it is composed of commercial shapes of iron at the current price, and because it allows of the design of different types, according to the resistance which it is proposed to obtain. It is easily possible to adopt it in secondary tracks, and obtain a cross-tie whose stability is better and durability longer, without sensible increase in the cost price.

This cross-tie is composed of two pieces of channel iron, or T iron, held together by clamps, between which the wood blocks, which are required for fastenings and as a means for distributing the pressure on the ballast, are squeezed. It presents the same advantages as the experimental cross-tie, and has, besides, the following: easy tamping, exposure of the blocks, readjusted if desired with shims, easy renewal of the pieces. The compression of the elements (wood and iron) is greater than in the first system, because of the tension given to the clamps and to the compression of the wood. It is a beam of armored wood.

In resistance, this new type of cross-tie presents the same superiority as that pointed out above, and which depends on its greater rigidity. The blocks of wood, parallelepiped in form, will be easy to make from the butts of rejected cross-ties. If made of beech, they will be creosoted to refusal, which will render the piece of wood antiseptic. If, on the contrary, the heart of oak is employed, a superficial coat will be sufficient to protect the upper face of the block.

In this type the fastenings will be sufficiently solid, by reason of the compression of the wood, especially if the reinforced metallic plate is adopted, and if care is taken to make the entire width of the collar of the screw spike bear on the base of the rail. The employment of treenails can prolong the existence of cross-ties whose fastenings have become bad, but it will not increase their resistance permanently if the wood is not compressed or sustained by a metallic girth. In every case the metallic treenails seem preferable to the wooden treenails, and are equally good in all other ways.

But, if the employment of cross-ties of the determined length is imposed by reason of the stability of the tracks, and if this necessitates the placing of sustaining shoes at the extremities, it is necessary to guard against indiscriminately employing and mixing short

cross-ties with long cross-ties. The disadvantages of simultaneously employing cross-ties of different lengths are many; the track becomes rough, and the deformations which are naturally produced are increased.

Mr. Couard demonstrated that the greatest deformation is produced at the joint; it can attain 0.79 in., and is due to the allowance which must be made when receiving rails from the mill, an allowance which is 0.02 in. at each of its extremities. The rails present the form of an inclined plane, and the depression, which is 0.02 in. in the beginning, increases with time under the influence of shocks, to 0.55 in. With the variable flexure of 0.12 in. which is due to the same cause, and the compression of the ballast, the total deflection is 0.79 in. The support of the joint and the straightening up of the extremities of the rails, in order to avoid all unequal level from the beginning, are absolutely required.

We conclude, then, that, in order to have tracks in a condition for supporting a heavy and rapid traffic, there are necessary:

First.—Cross-ties extremely rigid, two to three times more than those actually in use, which excludes in every case the employment of cross-ties exclusively of steel in the form of a trough.

Second.—The laying of the track with a cross-tie under the joint, that cross-tie being followed and preceded at 11.81 in. with cross-ties equally rigid.

Third.—The use of reinforced plates.

I do not pretend to give definite solutions, but to point out those which appear to me the most logical, and which promise good results. I have outlined a programme which should be followed up, if only partially, in order to verify the truth of my deductions.

I will be glad to have the experiments which I have made repeated, to have them criticised, to have anyone go back to the foundation of things, not being limited, as is now the case, to simply proving by means of ingenious apparatus the deformations produced. It is without doubt excellent to know them; but is it possible to deduce anything from them if the whole cause which has produced them is not sought for first? To repair the track at each point, where these deformations have appeared, is very well for the moment, but, since one has not been to the foundation of things, since the cause has not been destroyed, but only the effect, all that is left is to recommence and always to recommence, which is the work of Penelope.

I intend to continue the studies which I have commenced, to verify still more the observations which I have made, to corroborate them and to enlarge upon them. I only request to be followed, and that such distinguished engineers as the railroad companies possess put themselves to the work, giving account of the many things yet to be done, and how the actual track should be reinforced, if it is desired to increase the speed of traffic, while maintaining the security which it ought to give.





TABLE OF CONTENTS.

	PAGE.
AUTHOR'S PREFACE	i
TRANSLATOR'S PREFACE	vi
CHAPTER I.—NATURE AND OBJECT OF EXPERIMENTS.....	1
Ties Used	2
Characteristics of these Ties (Table).....	6
Experiments on the Side Track at Bourg-en-Bresse	7
CHAPTER II.—MOVEMENTS TO WHICH TRACK IS SUBJECTED.....	13
Longitudinal Movement	13
Transverse Movement	16
Curves of Deformation of Cross Ties.....	19
Measuring Apparatus for Static Experiments....	24
Measuring Apparatus for Dynamic Experiments.	25
Stock for Experiment.....	29
Experiments of May, 1903.....	33
Experiments of June, 1903.....	34
Experiments of July, 1903.....	36
Summary and Conclusion.....	37
CHAPTER III.—LENGTH TO GIVE TIES AND TAMPED BED.....	48
Dynamic Experiments	58
CHAPTER IV.—DEFORMATION OF THE TRACK.....	63
Creeping of the Track.....	63
Reduction of Gage on Tangents and Widening on Curves	66
Compression of Ties at the Supports.....	67
Pulling out Screw Spikes.....	68
Compression of Supports and Inclination of Rail (Table)	69
The <i>Extrahometre</i> and the <i>Declimetre</i>	70
Results of Tests with Above.....	71
Summary of Maximum Results Obtained (Table)	77
CHAPTER V.—DEFORMATION OF TIES.....	79
Stress of Metal and of Wood.....	81
Curve of Deformation of the Composite Tie....	81

	PAGE.
CHAPTER VI.—STRESS OF TIES IN THE TRACK.....	87
Shock at the Joint.....	91
Apparatus for Recording	93
Graphic Results	95
CHAPTER VII.—STUDY OF WOOD USED FOR TIES	108
Table of Losses of Moisture.....	110
Results of Preservative Processes.....	111
Treatment of Pine and Oak.....	117
Influence of Creosoting on Resistance to Com- pression	119
CHAPTER VIII.—METHODS FOR REMEDYING TRACK DEFORMATION.	121
Comparative Flexures Under Load; Wood and Composite Ties	122
Position of the Tie in the Track.....	123
Effect of Climatic Variations on the Tie.....	124
Length of Tie of Least Flexure.....	126
Composite Ties	129
Methods of Improving the Joint.....	132
Employment of the Treenail.....	137
Thiollier Treenail	139
Resistance to Sliding of Ties.....	140
CHAPTER IX.—RECAPITULATION AND CONCLUSIONS.....	142





750 mt

