

U F

765

46

UC-NRLF



5B 74 130

YC 6 0

GIFT OF

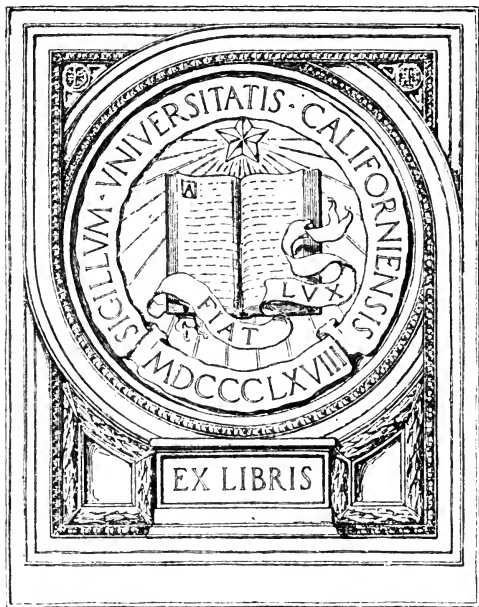

EX LIBRIS

Gaylord Bros.
Makers
Syracuse, N. Y.
PAT. MAR. 21 - 1908

9/12/17
No. 1741

DESCRIPTION AND INSTRUCTIONS
FOR THE USE OF

RIFLE AND HAND GRENADES

(FOUR PLATES)

MAY 18, 1911
REVISED JANUARY 12, 1917



WASHINGTON
GOVERNMENT PRINTING OFFICE

1917

No. 1741

U.S. Ordnance dept.

DESCRIPTION AND INSTRUCTIONS
FOR THE USE OF

RIFLE AND HAND GRENADES

(FOUR PLATES)

MAY 18, 1911
REVISED JANUARY 12, 1917



WASHINGTON
GOVERNMENT PRINTING OFFICE
1917

UF 765
U6

NO COPY
SUBMITTED

WAR DEPARTMENT,
OFFICE OF THE CHIEF OF ORDNANCE,
Washington, January 12, 1917.

This manual is published for the information and government of the Regular Army and National Guard of the United States.

By order of the Secretary of War:

WILLIAM CROZIER,
Brigadier General, Chief of Ordnance.

(3)

Digitized by the Internet Archive
in 2007 with funding from
Microsoft Corporation

WARNING!

TO PREVENT THE POSSIBILITY OF ACCIDENT WHEN USING GRENADES,
THE FOLLOWING SHOULD BE STRICTLY OBSERVED.

HAND GRENADES.

1. Do not use live grenades until practice has been had with dummies. Untrained men are very erratic and may injure bystanders.

2. If the grenade is "tossed," swinging in a vertical plane, great care must be taken not to hit the ground while swinging.

3. Do not throw a live grenade unless cover is at hand behind which the operator and spectators may seek shelter before the grenade strikes the ground. It is unsafe to remain in the open.

4. If a hand grenade fails, it should be recovered and placed in a deep stream or other body of water or buried in the ground.

5. In handling live grenades always hold the body in the hand, and never lift by means of the streamer. The rope sometimes breaks. This is particularly true after the grenade has been thrown.

RIFLE GRENADES.

1. Do not fire a live grenade unless cover is at hand behind which the firer and spectators may take shelter before the grenade strikes the ground. The stem of the grenade is sometimes thrown several hundred yards to the rear, and would make a dangerous if not fatal wound even at that distance.

2. If a rifle grenade fails, it should not be left where it might be picked up by an inexperienced person. It should be picked up with the stem pointing downward and should be kept in this position till placed in a deep stream or other body of water or buried in the ground.

3. If it is put aside until the end of the exercise, it is well to stick the stem in the ground so as to leave it standing upright. This position should be an indication as to its condition, as the stem of a grenade to be fired should not be put in earth in such a way that the central channel might be closed.

4. A grenade which has failed should not again be fired.

THE UNIVERSITY OF CHICAGO
LIBRARY

1511



SCALE

BABBITT RIFLE GRENADE.

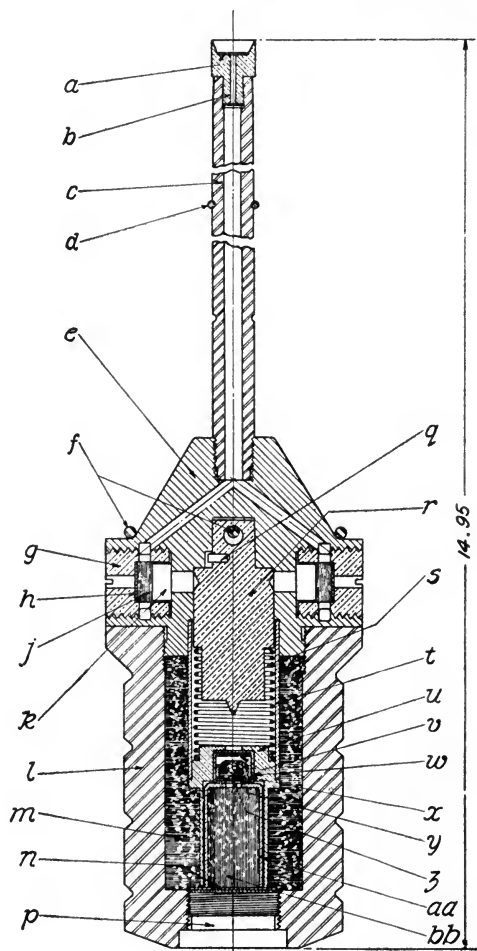

GRENADES.

The rifle grenade adopted by the Ordnance Department is that known as the Babbitt rifle grenade, and is illustrated in Plate I of this pamphlet. The rifle grenade is intended to be fired from a service magazine rifle, model of 1903, by use of a specially loaded blank cartridge.

The hand grenade has been developed simultaneously with the rifle grenade and the type adopted by the department is illustrated in Plate II of this pamphlet. This grenade is thrown by hand in much the same manner as a stone is thrown from a sling. These grenades are high explosive missiles and should be used at short ranges from behind cover.

Rifle and hand grenades are packed in boxes containing 32 each.

THE ACTION OF THE RIFLE GRENADE.

The construction of the rifle grenade and the nomenclature of its component parts are indicated in Plate I.

(PLATE I.)

NOMENCLATURE.

<i>a.</i> Paper disk.	<i>p.</i> Plug.
<i>b.</i> Sabot.	<i>q.</i> Plunger locking pin.
<i>c.</i> Stem.	<i>r.</i> Plunger.
<i>d.</i> Stem ring.	<i>s.</i> Plunger restraining spring.
<i>e.</i> Closing screw.	<i>t.</i> Casing.
<i>f.</i> Safety wire.	<i>u.</i> Primer holder.
<i>g.</i> Safety pellet screw.	<i>v.</i> Percussion composition.
<i>h.</i> Paper disk.	<i>w.</i> Primer covering.
<i>j.</i> Safety pellet.	<i>x.</i> Primer housing.
<i>k.</i> Safety pin.	<i>y.</i> Primer charge.
<i>l.</i> Body.	<i>z.</i> Primer closing disk.
<i>m.</i> Trinitrotoluol.	<i>aa.</i> Detonator cup.
<i>n.</i> Detonating cup filling disk.	<i>bb.</i> Detonating compound.

The grenade is designed to be fired at a constant angle of elevation, namely 45° , except as noted below for ranges under 50 yards. The range attained is dependent upon the length of the stem inserted in the bore of the rifle. Tests have shown that within considerable limits the range is but little affected by small changes in the angle of elevation, near 45° , while a change in the length of inserted stem gives an appreciable change in the range.

The rifle grenade should be set for range as follows: The grenade having been removed from its tin packing container, grasp the stem with the thumb down and the thumb nail in the groove marking the range desired. Insert the stem in the muzzle of the service rifle and shove down until the stem ring comes against the end of the thumb nail.

The special grenade cartridge is inserted in the chamber and the rifle fired either from the shoulder, or better by resting the butt on the ground, the firer kneeling to the left, fixing the direction and estimating the desired 45° elevation. The rifle should be held as firmly as possible.

Remove the safety wire *f*.

When the special blank cartridge above referred to is fired in the gun, the flaming gases from its charge serve the double purpose of ejecting the grenade from the rifle and of arming the fuse of the grenade. The latter action is accomplished as follows: The flame passes up through the bore of the stem *c*, through the passages in the closing screw *e*, and holes in the safety pellet screw *g*, and ignites the safety pellets *j*. The compressed rifle powder pellets serve, before being burned out, to hold the safety pins *k* in such a position that their conical points engage in the circumferential groove in the plunger *r*, and prevent this plunger from moving forward. It will thus be seen that the fuse can not be armed until after the exit of the grenade from the rifle. After the compressed rifle powder *j* has been consumed, and the safety pins *k* released, the plunger *r* is still restrained from moving forward and striking the primer covering *w*, by means of the plunger restraining spring *s*. Upon impact with the ground, after having been fired from the rifle in the manner stated, the plunger *r* moves quickly forward, striking the primer covering *w*, igniting the percussion composition *v*, which in turn ignites the primer charge *y* and this in turn ignites the detonating compound *bb*. The detonation of this compound causes the detonation of the trinitrotoluol filling *m*.

The detonation of the grenade upon impact is violent, and the grenade, body, and components are broken up into a number of effective fragments which have a considerable range, making it unsafe for the firers or observers to be in the open when the grenade detonates. At the proving ground the stems have been found over 300 yards in rear of the point of burst. Rifle grenades may also be fired point blank if desirable.

INSTRUCTIONS FOR USE OF THE RIFLE GRENADE.

Rifle grenades are shipped in bandoleers of olive-drab cloth, each of which contains four rifle grenades. The grenades are packed in

the bandoleer in hermetically sealed tin containers, each carrying one rifle grenade complete and one special blank cartridge for use in propelling the grenade. The bandoleer is opened by unfastening or tearing off the stripping tape. The tin containers are provided with a tearing-off strip which may be removed with the fingers. This should, however, not be done until the grenade is to be actually used. The bandoleer is carried over the shoulder, the end tapes being passed around the waist and tied in front or as may be most convenient. The weight of a complete bandoleer with four grenades, containers, and blank cartridges is 6 pounds 13.76 ounces; the weight of the packing can including the weight of the grenade and blank cartridge is 1 pound 10.16 ounces; the weight of the grenade proper is 1 pound 6.84 ounces, and the weight of the blank cartridge is 210 grains.

It will be noted that the stem *c* of the grenade is graduated with circular grooves corresponding to different lengths of insertion into the bore of the rifle, which in turn correspond to the various ranges. There is one set of graduations in yards of range based upon an angle of elevation of 45° . These graduations vary from 300 yards to 80 yards as a minimum. In order to cover the space between the minimum range as marked on the stem and the firing point, an angle of elevation of 80° may be used. With this angle of elevation, the ranges obtained will be approximately one-fifth of the ranges marked on the stem. The angle of elevation of 80° may be closely approximated by resting the butt of the rifle upon a level piece of ground or upon a board, the surface of which is horizontal. In other words, the angle between the horizontal surface and the bore of the rifle with the rifle in the position of "order arms" is approximately 80° .

A range table giving more exact ranges for both the live and the dummy rifle grenades is given below:

Live and dummy grenades, elevation 45° .		Live and dummy grenades, elevation 80° .	
Range.	Insert stem to graduation marked—	Range.	Insert stem to graduation marked—
Yards.	Yards.	Yards.	Yards.
80	80	15	80
100	100	20	100
120	120	26	120
140	140	32	140
160	160	38	160
180	180	44	180
200	200	50	200
220	220	56	220
240	240	63	240
260	260	70	260
280	280	77	280
300	300	85	300

The maximum pressure obtained from the special blank cartridge issued with the grenades is approximately 48,000 pounds per square inch, when the stem insertion is complete, i. e., when the stem ring stops against the closing screw of the grenade. This pressure corresponds, as may be seen from the range table, page 9, to a range of 300 yards.

In firing the rifle grenade it has been found that the best results can be obtained by resting the butt of the rifle on the ground and estimating the angle which the barrel makes with the horizontal, which angle, as stated above, should be either 45° or 80° , these angles being those used for the determination of the graduation upon the stem. It has been found that the rifle grenade is not detonated by impact of the small-arms bullet unless it so happens that the bullet actually strikes the fulminate composition *n*. It will also be observed that *no blank cartridges other than those issued by the Ordnance Department should be used with the rifle grenade. Failure to observe this caution may result in injury to both the men and the matériel.* Should a rifle grenade fail to detonate on impact after having been fired from a rifle, it should be handled with extreme caution, in view of the fact that the safety feature as described above has now been removed. To handle such a grenade, it should be carried with the stem down and if practicable thrown into deep water, from which its recovery is improbable. If that be not practicable, the grenade should be buried in the ground where it will not likely be recovered. If it should be necessary to disassemble a grenade, either fired or unfired, the work should be done only in the presence of a responsible person. To do this, place the grenade, stem down, in a vise or clamp. With a wrench unscrew the body and remove the plunger if free. If the plunger of a fired grenade can not be removed, the safety pellets have failed to burn out, and while the reassembled grenade would be safe, it would probably fail again. A grenade having once failed should not be again fired from the rifle.

DUMMY RIFLE GRENADES.

The dummy rifle grenade illustrated in Plate III is issued for instruction purposes, and is similar to the rifle grenade in Plate I of this pamphlet, except that the body is not provided with grooves. It may from this feature be distinguished readily from the live grenade. As a further precaution, this grenade is marked "DUMMY." The stem of this grenade is graduated in a manner entirely similar to the method used for the stem of the live grenade, and the weight of the dummy grenade is equal to that of the live grenade. The dummy grenade is for use in target practice. The graduations for the stem of the dummy grenade are given for the same ranges as in

DUMMY RIFLE GRENADE.

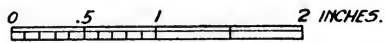
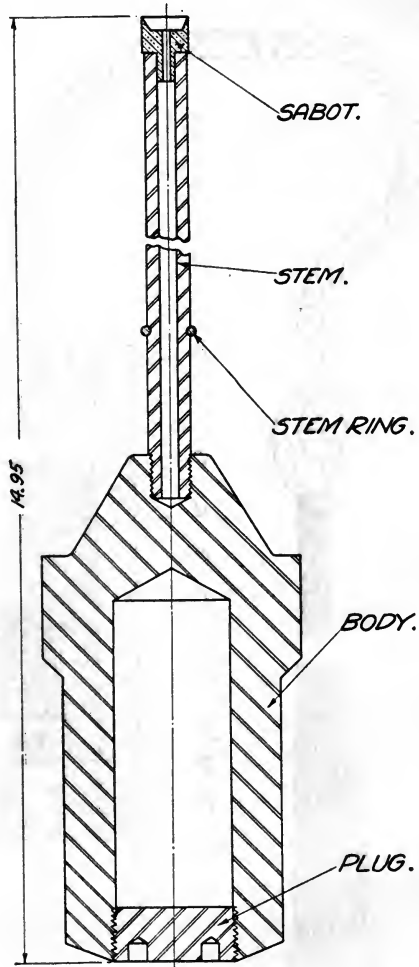

the case of the live grenade, but owing to the fact that the stem of the dummy grenade is solid and has no bore along its longitudinal axis, the ranges obtained with it are slightly greater than those obtained with the live grenade for equal lengths of stem insertion. In other words, for this and other reasons, the stems of the dummy and live grenades are not interchangeable. The range table for the grenade, both for 45° elevation and 80° elevation, is given on page 9. The manipulation of the dummy rifle grenade is entirely similar to that of the live grenade, so far as the stem insertion and firing from the rifle is concerned. The dummy grenade may be fired repeatedly. After the stem has become deformed the dummy grenade can again be made serviceable by the addition of a new stem. Each dummy rifle grenade issued is accompanied by 5 extra stems and 50 blank cartridges. These grenades are not issued in tin packing boxes or with bandoleers.

ACTION OF THE HAND GRENADE.

The construction of the hand grenade and the nomenclature of its component parts are indicated in Plate II:

(PLATE II.)

NOMENCLATURE.

a. Streamer.	l. Percussion composition.
b. Streamer holder.	m. Hood.
c. Body.	n. Firing pin.
d. Trinitrotoluol.	p. Fulminate composition.
e. Cup detonator.	q. Cup-detonator sleeve.
f. Filling washer.	r. Primer holder.
g. Primer closing disk.	s. Closing screw.
h. Primer covering.	t. Safety cup.
j. Primer charge.	u. Firing pin holder.
k. Primer housing.	

The action of the hand grenade is as follows: The hood *m* is removed from the grenade by twisting the hood in such a manner as to release the bayonet joint. The safety cup *t* is then removed and the hood replaced by repeating the motion of disassembling in reverse order, *care being exercised not to attempt to force the hood past the stop pins, as the safety feature has now been removed.* When the hood is in the proper position to cause the fuse to be armed, the stud in the body which engages in the bayonet-joint groove in the hood should be opposite the longitudinal continuation of the bayonet-joint slot. The fuse is now armed, and when the grenade is thrown so as to fall upon the firing-pin end the weight of the grenade causes the thin sections of the hood *m* to

be sheared by the small pins resting against the shearing sections, thus allowing the grenade to move downward into the hood, telescoping therewith, and strike the firing pin *n* against the percussion composition *l*. The impact of the firing pin ignites the percussion composition, which in turn ignites the powder *j*, causing the detonation of the fulminate composition *p* and of the trinitrotoluol *d*. These detonations result in the fragmentation of the grenade. The streamer or tail of the hand grenade is for the purpose of swinging the grenade in throwing. Preparatory to throwing the grenade the unravelled portion of the streamer should be wadded up in the palm of the hand and grasped together with the knot. In flight, the rope, acting as a tail, steadies the flight of the grenade and tends to cause it to strike head on in an advantageous manner for the successful action of the fuse.

INSTRUCTIONS FOR THE USE OF THE HAND GRENADE.

The grenade is issued in cylindrical tin cans, hermetically sealed, and provided with a tin tearing strip which should not be removed until just before the hand grenade is required for use. Four hand grenades are packed in these tin cans and carried in an olive drab bandoleer somewhat similar to that used for the transportation of small-arms ammunition. These bandoleers are provided with a strap so that the bandoleer can be suspended from the shoulders. This strap is folded across the back to the bandoleer and stitched in place with a weak stitching. Hooks are also provided so that the bandoleer may be suspended from the belt if this manner of carrying is preferred. The bandoleer pouch is divided into four compartments, each containing a hand grenade, and all are covered by a flap secured by a buckle so that the compartments may be readily opened for the extraction of the grenade.

Having taken the grenade from the bandoleer, the tin box is opened by tearing off the soldering strip, which releases the cover of the can. The hand grenade having been removed from the container, the grenade must be armed before it is thrown, and this is done by removing the safety cup *t*, as described above. Having armed the fuse of the grenade and replaced the hood *m* in the proper armed position, the grenade is ready to be thrown. In this condition the grenade should be carefully handled and not permitted to strike either on the ground adjacent to the thrower or in the vicinity of friendly troops. The thrower and all friendly troops should have cover before the grenades strike, as the fragments resulting from their detonation have a longer range than the distance to which the grenade as a whole may be thrown. The rope of the grenade is made in a convenient length for the soldier of average stature, but

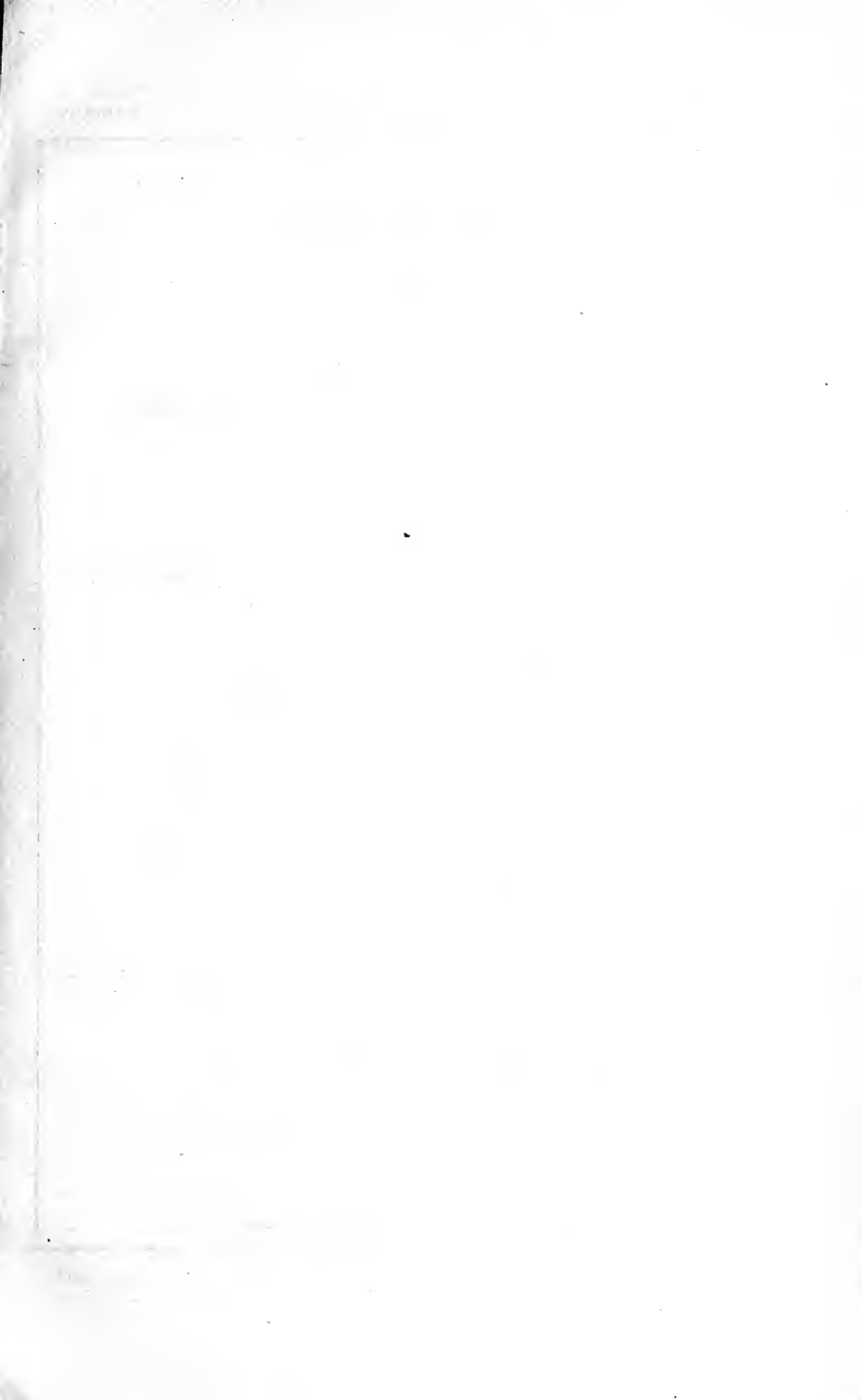

DUMMY HAND GRENADE.

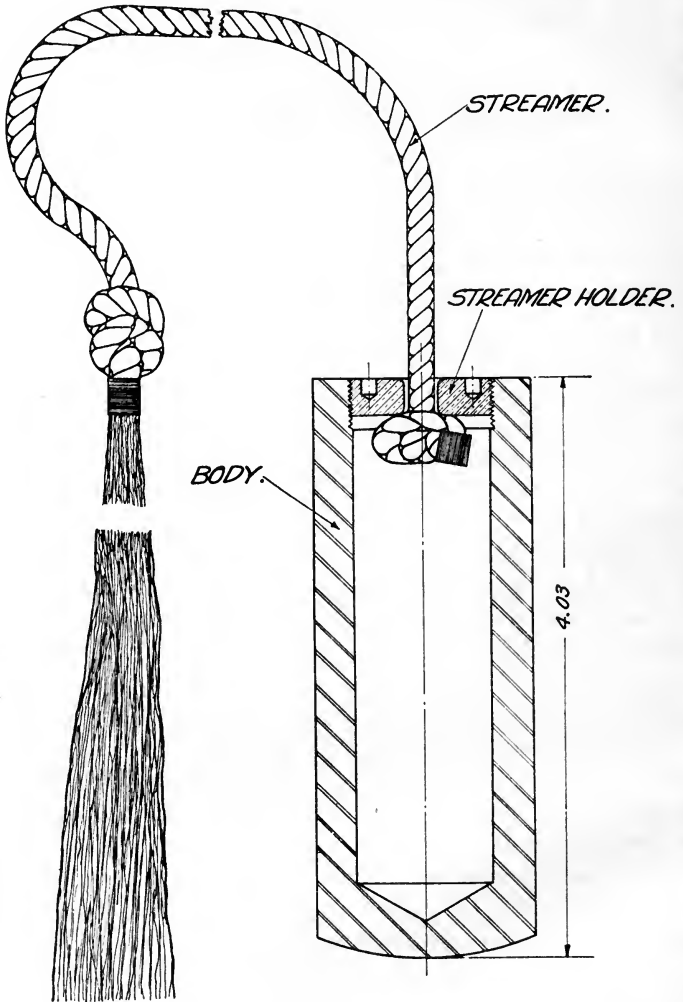

0.5 1 2 3 INCHES

this length may be decreased by adding another knot. The manner of throwing the grenade is dependent upon the free space available for swinging it. When the thrower has ample space behind a parapet, it is best to swing it around the head as with a sling, both for accuracy and safety. Untrained men will naturally swing the grenade in a vertical plane. The tests at the Sandy Hook Proving Ground indicate that this method is accompanied by considerable danger, as the thrower may strike the ground with the grenade in the act of whirling it or may release it so that its flight will be nearly vertical, causing the grenade to fall back near the thrower. The ranges that can be attained with this form of grenade are not great and vary with the strength and skill of the thrower. Prior to using service grenades, troops should be instructed in the use of dummy grenades. In assembling the hood *m*, after removing the safety cup *t*, *care should be taken not to attempt to force the hood too far upon the butt of the grenade body, or explosion may occur.* The rope of the grenade should also be examined to make sure it is in good condition and not liable to break while the grenade is being whirled.

In case a grenade which has been thrown and failed to detonate is recovered, it should be handled with the greatest care. Such grenades can be rendered safe for transportation by cautiously withdrawing the hood *m* from the grenade body, replacing the safety cup *t* in the hood, and then reassembling the hood to the grenade body. Or in case it be desired to throw the grenade a second time, this may be accomplished by drawing back the hood *m* until it will have its normal stroke upon impact and then throwing in the usual manner. However, if practicable, a grenade which has failed should be thrown into deep water from which its recovery is improbable, or should be buried in the ground.

The weight of the bandoleer packed with four containers and hand grenades is 6 pounds, and the weight of one hand grenade complete is 1 pound 5 ounces. The weight of the tin container is 1.92 ounces, and the weight of the bandoleer is 4.32 ounces.

DUMMY HAND GRENADES.

Dummy hand grenades are issued for instruction purposes and for practice in throwing grenades. These dummies are similar in weight and form to the live grenade, except that the body of the grenade is made of bronze instead of cast iron or steel and not grooved, but smooth upon its exterior surface so as to distinguish it from the live grenade, which is provided with grooves. The dummy hand grenade is also marked with the word "DUMMY." The cords attached to the dummy grenades will, with continued use, become worn and for

this reason the cord should be examined before whirling the grenade, in order to avoid accidents. To obtain accuracy and range in throwing the hand grenade requires preliminary drill and practice with the dummy grenade. For maximum effect the grenade should be detonated within a few feet of the object at which it is thrown. This requires accuracy usually acquired only by a considerable amount of practice. The dummy hand grenade is shown in Plate IV.

With each dummy hand grenade are issued five extra streamers.

WAR DEPARTMENT,

OFFICE OF THE CHIEF OF ORDNANCE.

Washington, January 12, 1917.

May 18, 1911.

Revised January 12, 1917.

FORM No. 1741.

Ed. Jan. 12-17—5,000.

INDEX.

	Page.
Dummy hand grenades.....	13
Dummy rifle grenades.....	10
General description.....	7
Hand grenade:	
Action.....	11
Instructions for use.....	12
Nomenclature.....	11
Range table.....	9
Rifle grenade:	
Action.....	7
Instructions for use.....	8
Nomenclature.....	7
Warning.....	5



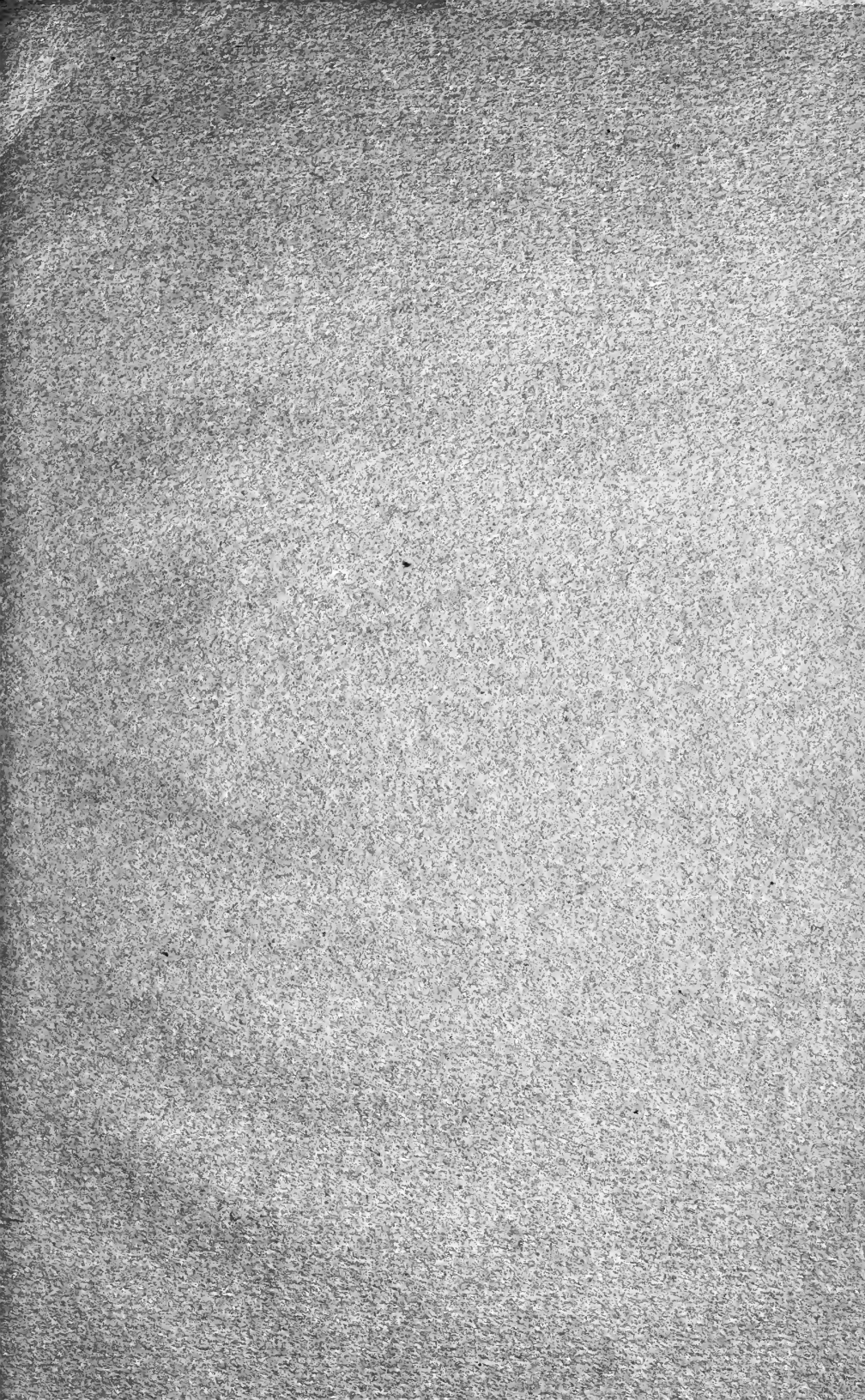

**THIS BOOK IS DUE ON THE LAST DATE
STAMPED BELOW**

AN INITIAL FINE OF 25 CENTS

**WILL BE ASSESSED FOR FAILURE TO RETURN
THIS BOOK ON THE DATE DUE. THE PENALTY
WILL INCREASE TO 50 CENTS ON THE FOURTH
DAY AND TO \$1.00 ON THE SEVENTH DAY
OVERDUE.**

SEP 28 1943

AUG 26 1996

RECEIVED

JUL 27 1996

CIRCULATION DEPT.

LD 21-100m-7,'39 (402s)

YC 64370

U C. BERKELEY LIBRARIES



C057101686

363173

U.S.

UF765

46

UNIVERSITY OF CALIFORNIA LIBRARY

