



This is a digital copy of a book that was preserved for generations on library shelves before it was carefully scanned by Google as part of a project to make the world's books discoverable online.

It has survived long enough for the copyright to expire and the book to enter the public domain. A public domain book is one that was never subject to copyright or whose legal copyright term has expired. Whether a book is in the public domain may vary country to country. Public domain books are our gateways to the past, representing a wealth of history, culture and knowledge that's often difficult to discover.

Marks, notations and other marginalia present in the original volume will appear in this file - a reminder of this book's long journey from the publisher to a library and finally to you.

### **Usage guidelines**

Google is proud to partner with libraries to digitize public domain materials and make them widely accessible. Public domain books belong to the public and we are merely their custodians. Nevertheless, this work is expensive, so in order to keep providing this resource, we have taken steps to prevent abuse by commercial parties, including placing technical restrictions on automated querying.

We also ask that you:

- + *Make non-commercial use of the files* We designed Google Book Search for use by individuals, and we request that you use these files for personal, non-commercial purposes.
- + *Refrain from automated querying* Do not send automated queries of any sort to Google's system: If you are conducting research on machine translation, optical character recognition or other areas where access to a large amount of text is helpful, please contact us. We encourage the use of public domain materials for these purposes and may be able to help.
- + *Maintain attribution* The Google "watermark" you see on each file is essential for informing people about this project and helping them find additional materials through Google Book Search. Please do not remove it.
- + *Keep it legal* Whatever your use, remember that you are responsible for ensuring that what you are doing is legal. Do not assume that just because we believe a book is in the public domain for users in the United States, that the work is also in the public domain for users in other countries. Whether a book is still in copyright varies from country to country, and we can't offer guidance on whether any specific use of any specific book is allowed. Please do not assume that a book's appearance in Google Book Search means it can be used in any manner anywhere in the world. Copyright infringement liability can be quite severe.

### **About Google Book Search**

Google's mission is to organize the world's information and to make it universally accessible and useful. Google Book Search helps readers discover the world's books while helping authors and publishers reach new audiences. You can search through the full text of this book on the web at <http://books.google.com/>

ENGIN. L. 3.

TK  
5865  
S62  
1922

# DESIGN DATA FOR RADIO TRANSMITTERS & RECEIVERS

A 759,716

DUPL



SIMPLE METHODS FOR DESIGNING APPARATUS  
ACCORDING TO ADVANCED AND APPROVED PRACTICE

*By*

M. B. SLEEPER

⑥

EVERYDAY ENGINEERING SERIES  
NORMAN W. HENLEY PUBLISHING CO.  
2 WEST 45 TH STREET, NEW YORK

1922 EDITION

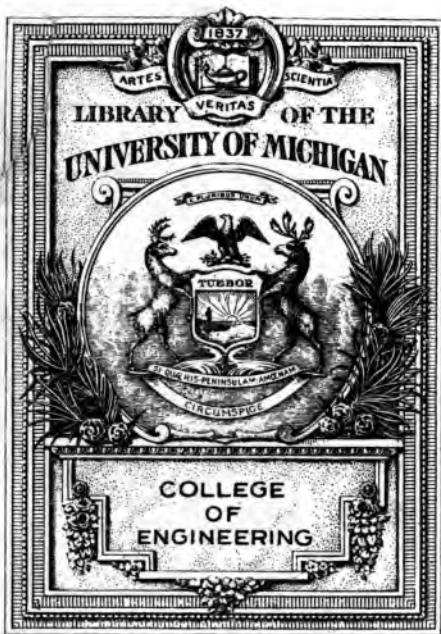





# DESIGN DATA

FOR RADIO TRANSMITTERS  
AND RECEIVERS

A REFERENCE BOOK OF TABLES AND SIMPLIFIED  
FORMULAS NECESSARY FOR THE CORRECT  
DESIGN OF RADIO CIRCUITS

ENGINEERING DATA IS MADE AVAILABLE TO THE  
EXPERIMENTERS, AND HELPFUL TABLES ARE  
PRESENTED TO THE RADIO ENGINEER

*edit*  
BY  
**M. B. SLEEPER**

Radio Editor, "Everyday Engineering Magazine"  
Author of "Radio Hook-Ups," "Radio Experimenter's  
Handbook," "Electric Bells," etc.

44

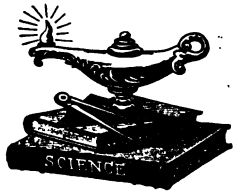

NEW YORK  
THE NORMAN W. HENLEY PUBLISHING CO.  
2 WEST 45TH STREET  
1922



Public Library

TK

5865

.S62

1922



Engin. - Rep2acc  
W2ht  
10-22-25  
12420

Mr.  
5525  
7-1-25  
1120

COPYRIGHTED, 1920, 1922  
BY  
THE NORMAN W. HENLEY PUBLISHING CO.



PRINTED IN U. S. A.



Composition, Electrotyping and Press Work  
By Publishers Printing Company, New York



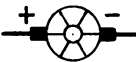

~ LIST OF SYMBOLS ~

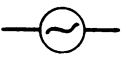
Battery ----- 

Direct Current Dynamo ---  or 

Alternating Current Generator } -----  or 

Fixed Capacitance (Condenser) -----  or 

Variable Capacitance (Var. Condenser) ----- 

Fixed Inductance (Air Core Coil) ----- 

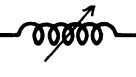
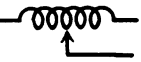
Variable Inductance (Air Core Coil) -----  or 

Variometer (Variable Inductance) --- 

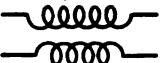
Fixed Coupling of Coils (Fixed Inductive Coupling) ----- 

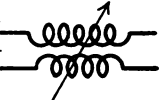









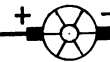



Variable Coupling of Coils ----- 

Transformer ----- 

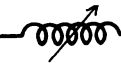
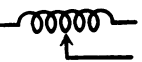
Iron Core Inductance (or Reactance Coil) ----- 

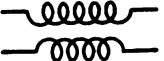

- LIST OF SYMBOLS -

- Battery ..... 
- Direct Current Dynamo ---  or 
- Alternating Current Generator } .....  or 
- Fixed Capacitance (Condenser) .....  or 
- Variable Capacitance (Var. Condenser) ..... 
- Fixed Inductance (Air Core Coil) ..... 
- Variable Inductance (Air Core Coil) .....  or 
- Variometer (Variable Inductance) --- 
- Fixed Coupling of Coils (Fixed Inductive Coupling) ..... 
- Variable Coupling of Coils ..... 
- Transformer ..... 
- Iron Core Inductance (or Reactance Coil) ..... 

~ LIST OF SYMBOLS ~

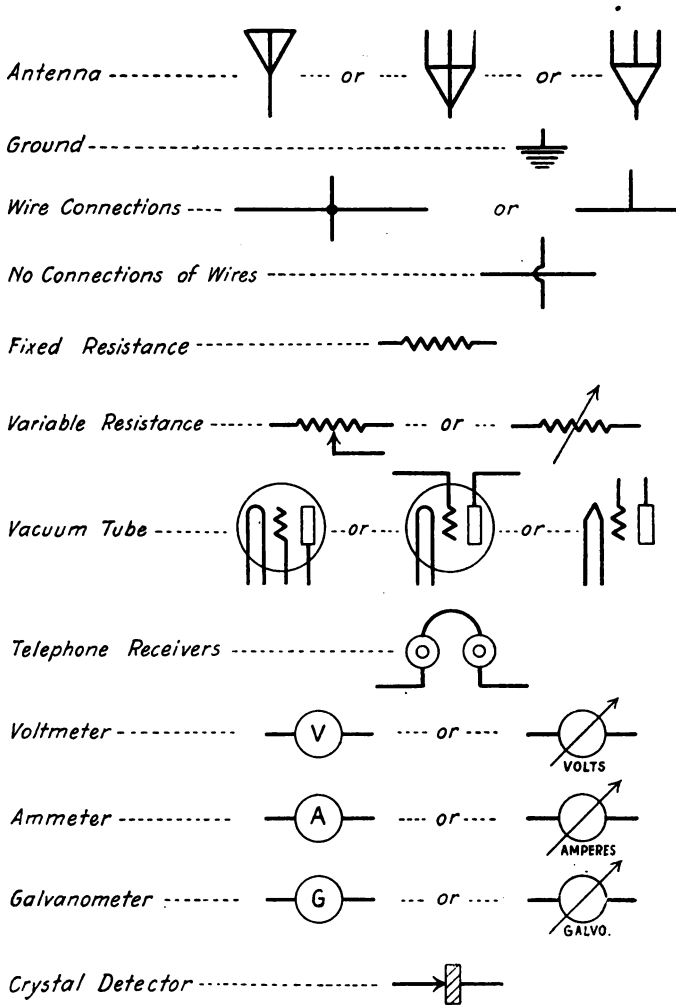



## PREFACE

PROBABLY because radio experimenters operate their instruments first, and learn about them afterward, they generally remain ignorant of the simple factors of design, the familiarity with which makes wireless work infinitely more interesting. If stations incorrectly designed, or just put together, would not work, this condition would be rectified, although radio might be less popular.

The essential problems have been stripped of mathematics which are beyond the average experimenter, in order that any one can build apparatus for a given performance.

Receiving circuits have been treated at greater length than sending sets, partly because there is more to say about them, and also because of the limitations of practicability in constructing transmitting apparatus at home.

FEBRUARY, 1922.



## MEANING OF SYMBOLS USED IN FORMULAS

- $A$  = area of dielectric, in square inches.  
 $av.$  = average.  
 $C$  = capacity, in mfd.  
 $d$  = diameter, in inches.  
 $E$  = volts.  
 $E_c$  = grid charge, in volts.  
 $f$  = frequency, in cycles.  
 $I$  = amperes.  
 $I_a$  = filament current, in amperes.  
 $K$  = coefficient of coupling.  
 $k$  = constant.  
 $L$  = inductance in centimeters.  
 $l$  = length in inches.  
 $l_a$  = axial width of torus of rectangular cross section, in inches.  
 $M$  = mutual inductance in centimeters.  
 $n$  = number of turns per inch.  
 $r$  = radius, in inches.  
 $r_a$  = distance from center of torus to center of cross-section of winding, in inches.  
 $r_b$  = radius of cross-section of torus, in inches.  
 $R_c$  = resistance in filament circuit to put charge on grid, in ohms.  
 $t$  = thickness of dielectric, in inches.  
 $t.p.i.$  = turns per inch.  
 $\lambda$  = wave-length, in meters.

# CONTENTS

## CHAPTER I

### OSCILLATING CIRCUITS

	PAGE
Electrical Oscillations.—Wave-length and Frequency.—Wave-length Inductance and Capacity.—Wave-length Frequency Table.—Wave-length Capacity and Inductance Table.—Effective Capacity Table.—Frequency, Inductance, Capacity.—Inductance in Circuit.—Coefficient of Coupling.—Capacity in Circuit . . . . .	1-20

## CHAPTER II

### RADIO ANTENNAS

Antennas.—Loop Antennas.—Condenser Antennas.—Airplane Antennas.—Antenna Resistance.—Antenna Capacity.—Antenna Inductance . . . . .	21-30
--	-------

## CHAPTER III

### DESIGN OF INDUCTANCES

Losses in Inductances.—Inductance Constant Table.—Table of Turns per Inch of Wire.—Feet per Pound of Copper Wire Table.—Bank Wound Coils.—Figure Eight Coils.—Table of Constants for Inductance of Figure Eight Coils.—Single Layer Solenoids.—Multilayer Coils.—Toroidal Coils.—Staggered Coils.—Variation of Coupling.—Variation of Inductance . . . . .	31-44
--	-------

## CHAPTER IV

### DESIGN OF RECEIVING CONDENSERS

Capacity of an Air Condenser.—Losses in Receiving Condensers.—Types of Variable Condensers.—Design Features.—Mica and Paper Condensers . . . . .	45-50
--	-------

## CHAPTER V

## AUDION DETECTIVE CIRCUITS

	PAGE
Three Circuits of the Audion.—Audion Characteristics.—Grid Circuit.—Plate Circuit . . . . .	51-58

## CHAPTER VI

OSCILLATING AUDION CIRCUITS AND UNDAMPED  
WAVE-RECEIVERS

Inductively Coupled Oscillators.—Capacity Couple Oscillators. —Locally Oscillating Circuits for Undamped Wave Reception.—Separate Oscillators . . . . .	59-65
--	-------

## CHAPTER VII

## DAMPED WAVE TRANSMITTERS

Spark Sets.—Transformer Sets.—Transfer and Lighting Switches . . . . .	66-77
---	-------

## CHAPTER VIII

## VACUUM TUBE TRANSMITTERS

Essentials of Vacuum Tube Transmitting Circuits.—Simple Transmitter.—Modulated Transmitter.—Telephone Transmitter.—Another Type of Transmitter.—Loop Transmitters	78-85
--	-------

# DESIGN DATA FOR RADIO TRANSMITTERS AND RECEIVERS

## PART I

### CHAPTER I

#### OSCILLATING CIRCUITS

##### 1. ELECTRICAL OSCILLATIONS.

Electrical oscillations can take place in a circuit containing inductance, capacity, and, necessarily, resistance, provided the resistance in ohms does not exceed

$$2\sqrt{\frac{L}{1,000 \times C}} \dots \dots \dots (1)$$

##### 2. WAVE-LENGTH AND FREQUENCY.

Since electricity travels at the speed of light, 300,000,000 meters per second, the wave-length of a circuit, in respect to the frequency of the oscillations, is

$$\lambda = \frac{300,000,000}{f} \dots \dots \dots (2)$$

Table 1 gives the frequencies corresponding to wave-lengths from 100 to 39,000 meters.

##### 3. WAVE-LENGTH, INDUCTANCE AND CAPACITY.

The wave-length, and, therefore, the oscillation frequency, depend upon the amount of inductance and capacity in the circuit. Table 2 shows the wave-lengths of circuits having from 1,000 cms. inductance and 0.0001 mfd. capacity to 600,000,000 cms. and 0.002 mfd.

*H.C.B.*

*Design Data*

TABLE I—FREQUENCY AND WAVE-LENGTH

Meters	Frequency	Meters	Frequency	Meters	Frequency
100	3,000,000	525	572,000	750	400,000
110	2,727,000	530	566,000	755	397,000
120	2,500,000	535	561,000	760	395,000
130	2,308,000	540	556,000	765	392,000
140	2,143,000	545	551,000	770	390,000
150	2,000,000	550	546,000	775	387,000
160	1,875,000	555	541,000	780	385,000
170	1,764,000	560	536,000	785	382,000
180	1,667,000	565	531,000	790	380,000
190	1,579,000	570	527,000	795	377,000
200	1,500,000	575	522,000	800	375,000
210	1,429,000	580	517,000	805	373,000
220	1,364,000	585	513,000	810	370,000
230	1,304,000	590	509,000	815	368,000
240	1,250,000	595	504,000	820	366,000
250	1,200,000	600	500,000	825	364,000
260	1,154,000	605	496,000	830	361,000
270	1,111,000	610	492,000	835	359,000
280	1,071,000	615	488,000	840	357,000
290	1,034,000	620	484,000	845	355,000
300	1,000,000	625	480,000	850	353,000
310	968,000	630	476,000	855	351,000
320	938,000	635	472,000	860	349,000
330	909,000	640	469,000	865	347,000
340	883,000	645	465,000	870	345,000
350	857,000	650	462,000	875	343,000
360	834,000	655	458,000	880	341,000
370	811,000	660	455,000	885	339,000
380	790,000	665	451,000	890	337,000
390	769,000	670	448,000	895	335,000
400	750,000	675	444,000	900	333,000
410	732,000	680	441,000	905	331,000
420	715,000	685	438,000	910	330,000
430	698,000	690	435,000	915	328,000
440	682,000	695	432,000	920	326,000
450	667,000	700	429,000	925	324,000
460	652,000	705	426,000	930	323,000
470	639,000	710	423,000	935	321,000
480	625,000	715	420,000	940	319,000
490	612,000	720	417,000	945	317,000
500	600,000	725	414,000	950	316,000
505	594,000	730	411,000	955	314,000
510	588,000	735	408,000	960	313,000
515	583,000	740	405,000	965	311,000
520	577,000	745	403,000	970	309,000

*For Radio Transmitters*

TABLE I—(Continued)

Meters	Frequency	Meters	Frequency	Meters	Frequency
975	308,000	1400	214,300	1850	162,200
980	306,000	1410	212,800	1860	161,300
985	305,000	1420	211,300	1870	160,400
990	303,000	1430	209,800	1880	159,600
995	302,000	1440	208,300	1890	158,700
1000	300,000	1450	206,900	1900	157,900
1010	297,100	1460	205,500	1910	157,100
1020	294,200	1470	204,100	1920	156,300
1030	291,300	1480	202,700	1930	155,400
1040	288,500	1490	201,300	1940	154,600
1050	285,700	1500	200,000	1950	153,800
1060	283,000	1510	198,700	1960	153,100
1070	280,400	1520	197,400	1970	152,300
1080	277,800	1530	196,100	1980	151,500
1090	275,200	1540	194,800	1990	150,800
1100	272,700	1550	193,500	2000	150,000
1110	270,300	1560	192,300	2020	148,500
1120	267,900	1570	191,100	2040	147,100
1130	265,500	1580	189,900	2060	145,600
1140	263,200	1590	188,700	2080	144,200
1150	260,900	1600	187,500	2100	142,900
1160	258,600	1610	186,300	2120	141,500
1170	256,400	1620	185,100	2140	140,200
1180	254,200	1630	184,000	2160	138,900
1190	252,100	1640	182,900	2180	137,600
1200	250,000	1650	181,800	2200	136,400
1210	247,900	1660	180,700	2220	135,100
1220	245,900	1670	179,600	2240	133,900
1230	243,900	1680	178,500	2260	132,700
1240	241,900	1690	177,400	2280	131,600
1250	240,000	1700	176,400	2300	130,400
1260	238,100	1710	175,400	2320	129,300
1270	236,200	1720	174,400	2340	128,200
1280	234,400	1730	173,400	2360	127,100
1290	232,600	1740	172,400	2380	126,000
1300	230,800	1750	171,400	2400	125,000
1310	229,000	1760	170,500	2420	124,000
1320	227,300	1770	169,500	2440	122,900
1330	225,600	1780	168,500	2460	121,900
1340	223,900	1790	167,600	2480	121,000
1350	222,200	1800	166,700	2500	120,000
1360	220,600	1810	165,700	2520	119,000
1370	219,000	1820	164,800	2540	118,100
1380	217,400	1830	163,900	2560	117,200
1390	215,800	1840	163,000	2580	116,300

*Design Data*

TABLE I—(Continued)

Meters	Frequency	Meters	Frequency	Meters	Frequency
2600	115,400	3500	85,700	4400	68,200
2620	114,500	3520	85,300	4420	67,900
2640	113,600	3540	84,800	4440	67,600
2660	112,800	3560	84,300	4460	67,300
2680	111,900	3580	83,800	4480	67,000
2700	111,100	3600	83,400	4500	66,700
2720	110,300	3620	82,900	4520	66,400
2740	109,500	3640	82,400	4540	66,100
2760	108,700	3660	82,000	4560	65,800
2780	107,900	3680	81,500	4580	65,500
2800	107,100	3700	81,100	4600	65,200
2820	106,400	3720	80,700	4620	65,000
2840	105,600	3740	80,200	4640	64,700
2860	104,900	3760	79,800	4660	64,400
2880	104,200	3780	79,400	4680	64,100
2900	103,400	3800	79,000	4700	63,900
2920	102,700	3820	78,600	4720	63,600
2940	102,000	3840	78,200	4740	63,300
2960	101,300	3860	77,700	4760	63,000
2980	100,700	3880	77,300	4780	62,800
3000	100,000	3900	76,900	4800	62,500
3020	99,400	3920	76,500	4820	62,300
3040	98,700	3940	76,200	4840	62,000
3060	98,100	3960	75,800	4860	61,800
3080	97,400	3980	75,400	4880	61,500
3100	96,800	4000	75,000	4900	61,200
3120	96,200	4020	74,700	4920	61,000
3140	95,600	4040	74,300	4940	60,800
3160	95,000	4060	73,900	4960	60,500
3180	94,400	4080	73,600	4980	60,300
3200	93,800	4100	73,200	5000	60,000
3220	93,200	4120	72,800	5050	59,400
3240	92,600	4140	72,500	5100	58,800
3260	92,000	4160	72,100	5150	58,300
3280	91,500	4180	71,800	5200	57,700
3300	90,900	4200	71,500	5250	57,200
3320	90,400	4220	71,100	5300	56,600
3340	89,800	4240	70,800	5350	56,100
3360	89,300	4260	70,400	5400	55,600
3380	88,800	4280	70,100	5450	55,100
3400	88,300	4300	69,800	5500	54,600
3420	87,700	4320	69,500	5550	54,100
3440	87,200	4340	69,100	5600	53,600
3460	86,700	4360	68,800	5650	53,100
3480	86,200	4380	68,500	5700	52,700

TABLE I—(Continued)

Meters	Frequency	Meters	Frequency	Meters	Frequency
5750	52,200	8000	37,500	10500	28,600
5800	51,700	8050	37,300	10600	28,300
5850	51,300	8100	37,000	10700	28,000
5900	50,900	8150	36,800	10800	27,800
5950	50,400	8200	36,600	10900	27,500
6000	50,000	8250	36,400	11000	27,300
6050	49,600	8300	36,100	11100	27,000
6100	49,200	8350	35,900	11200	26,800
6150	48,800	8400	35,700	11300	26,500
6200	48,400	8450	35,500	11400	26,300
6250	48,000	8500	35,300	11500	26,100
6300	47,600	8550	35,100	11600	25,900
6350	47,200	8600	34,900	11700	25,600
6400	46,900	8650	34,700	11800	25,400
6450	46,500	8700	34,500	11900	25,200
6500	46,200	8750	34,300	12000	25,000
6550	45,800	8800	34,100	12100	24,800
6600	45,500	8850	33,900	12200	24,600
6650	45,100	8900	33,700	12300	24,400
6700	44,800	8950	33,500	12400	24,200
6750	44,400	9000	33,300	12500	24,000
6800	44,100	9050	33,100	12600	23,800
6850	43,800	9100	33,000	12700	23,600
6900	43,500	9150	32,800	12800	23,400
6950	43,200	9200	32,600	12900	23,300
7000	42,900	9250	32,400	13000	23,100
7050	42,600	9300	32,300	13100	22,900
7100	42,300	9350	32,100	13200	22,700
7150	42,000	9400	31,900	13300	22,600
7200	41,700	9450	31,700	13400	22,400
7250	41,400	9500	31,600	13500	22,200
7300	41,100	9550	31,400	13600	22,100
7350	40,800	9600	31,300	13700	21,900
7400	40,500	9650	31,100	13800	21,700
7450	40,300	9700	30,900	13900	21,600
7500	40,000	9750	30,800	14000	21,400
7550	39,700	9800	30,600	14100	21,300
7600	39,500	9850	30,500	14200	21,100
7650	39,200	9900	30,300	14300	21,000
7700	39,000	9950	30,200	14400	20,800
7750	38,700	10000	30,000	14500	20,700
7800	38,500	10100	29,700	14600	20,600
7850	38,200	10200	29,400	14700	20,400
7900	38,000	10300	29,100	14800	20,300
7950	37,700	10400	28,800	14900	20,100



*Design Data*

TABLE I—(Continued)

Meters	Frequency	Meters	Frequency	Meters	Frequency
15000	20,000	18700	16,040	24800	12,100
15100	19,870	18800	15,960	25000	12,000
15200	19,740	19800	15,870	25200	11,900
15300	19,610	19000	15,790	25400	11,810
15400	19,480	19100	15,710	25600	11,720
15500	19,350	19200	15,630	25800	11,630
15600	19,230	19300	15,540	26000	11,540
15700	19,110	19400	15,460	26200	11,450
15800	18,990	19500	15,380	26400	11,360
15900	18,870	19600	15,310	26600	11,280
16000	18,750	19700	15,230	26800	11,190
16100	18,630	19800	15,150	27000	11,110
16200	18,510	19900	15,080	27200	11,030
16300	18,400	20000	15,000	27400	10,950
16400	18,290	20200	14,850	27600	10,870
16500	18,180	20400	14,710	27800	10,790
16600	18,070	20600	14,560	28000	10,710
16700	17,960	20800	14,420	28200	10,640
16800	17,850	21000	14,290	28400	10,560
16900	17,740	21200	14,150	28600	10,490
17000	17,640	21500	14,020	28800	10,420
17100	17,540	21600	13,890	29000	10,340
17200	17,440	21800	13,760	29200	10,270
17300	17,340	22000	13,640	29400	10,200
17400	17,240	22200	13,510	29600	10,130
17500	17,140	22400	13,390	29800	10,070
17600	17,050	22600	13,270	30000	10,000
17700	16,950	22800	13,160	31000	9,680
17800	16,850	23000	13,040	32000	9,380
17900	16,760	23200	12,930	33000	9,090
18000	16,670	23400	12,820	34000	8,830
18100	16,570	23600	12,710	35000	8,570
18200	16,480	23800	12,600	36000	8,340
18300	16,390	24000	12,500	37000	8,110
18400	16,300	24200	12,400	38000	7,900
18500	16,220	24400	12,290	39000	7,690
18600	16,130	24600	12,190		

TABLE II—WAVE-LENGTH WITH C mfd. AND L cms.

C mfd.	1,000 cms.	2,000 cms.	3,000 cms.	4,000 cms.	5,000 cms.
0.0001.....	19	27	33	38	42
0.0002.....	27	38	46	53	60
0.0003.....	33	46	57	65	73
0.0004.....	38	53	65	75	84
0.0005.....	42	60	73	84	94
0.0006.....	46	65	80	92	103
0.0007.....	50	71	86	100	112
0.0008.....	53	75	92	107	119
0.0009.....	57	80	98	113	126
0.0010.....	60	84	103	119	133
0.0011.....	63	88	108	125	140
0.0012.....	65	92	113	131	146
0.0013.....	68	96	118	136	152
0.0014.....	70	100	122	141	158
0.0015.....	73	103	126	146	163
0.0016.....	75	107	131	150	169
0.0017.....	78	110	135	155	174
0.0018.....	80	113	139	160	179
0.0019.....	82	116	142	164	184
0.0020.....	84	119	146	169	188

C	6,000	7,000	8,000	9,000	10,000
0.0001.....	46	50	53	57	60
0.0002.....	65	71	75	80	84
0.0003.....	80	86	92	98	103
0.0004.....	92	100	107	113	119
0.0005.....	103	112	119	126	133
0.0006.....	113	122	131	139	146
0.0007.....	122	132	141	150	158
0.0008.....	131	141	151	160	169
0.0009.....	139	150	160	170	179
0.0010.....	146	158	169	179	188
0.0011.....	153	165	177	188	198
0.0012.....	160	173	185	196	206
0.0013.....	166	180	192	204	215
0.0014.....	173	187	199	212	223
0.0015.....	179	193	206	219	231
0.0016.....	185	199	213	226	238
0.0017.....	190	206	220	233	246
0.0018.....	196	212	226	240	253
0.0019.....	201	217	232	246	260
0.0020.....	206	223	238	253	267

*Design Data*

TABLE II—(Continued)

C	12,000	14,000	16,000	18,000	20,000
0.0001.....	65	71	75	80	84
0.0002.....	92	100	107	113	119
0.0003.....	113	122	131	139	146
0.0004.....	131	141	151	160	169
0.0005.....	146	158	169	179	188
0.0006.....	160	173	185	196	206
0.0007.....	173	187	199	212	223
0.0008.....	185	199	213	226	238
0.0009.....	196	212	226	240	253
0.0010.....	206	223	238	253	267
0.0011.....	217	234	250	265	280
0.0012.....	226	244	261	277	292
0.0013.....	235	254	272	288	304
0.0014.....	244	264	282	299	315
0.0015.....	253	273	292	310	326
0.0016.....	261	282	302	320	337
0.0017.....	269	291	311	330	348
0.0018.....	277	299	320	339	358
0.0019.....	285	307	329	349	367
0.0020.....	292	315	337	358	377

C	25,000	30,000	40,000	50,000	60,000
0.0001.....	94	103	119	133	146
0.0002.....	133	146	169	188	206
0.0003.....	163	179	206	231	253
0.0004.....	188	206	238	267	292
0.0005.....	211	231	267	298	326
0.0006.....	231	253	292	326	358
0.0007.....	249	273	315	353	386
0.0008.....	267	292	337	377	413
0.0009.....	283	310	358	400	438
0.0010.....	298	326	377	421	462
0.0011.....	313	342	395	442	484
0.0012.....	326	358	413	462	506
0.0013.....	340	372	430	481	526
0.0014.....	353	386	446	499	546
0.0015.....	365	400	462	516	565
0.0016.....	377	413	477	533	584
0.0017.....	389	426	491	550	602
0.0018.....	400	438	506	565	619
0.0019.....	411	450	520	581	637
0.0020.....	421	462	533	596	653

*For Radio Transmitters*

TABLE II—(Continued)

C	70,000	80,000	90,000	100,000	120,000
0.0001.....	158	169	179	188	206
0.0002.....	223	238	253	267	292
0.0003.....	273	292	310	326	358
0.0004.....	315	337	358	377	413
0.0005.....	353	377	400	421	462
0.0006.....	386	413	438	462	506
0.0007.....	417	446	473	499	546
0.0008.....	446	477	506	533	584
0.0009.....	473	506	536	565	619
0.0010.....	499	533	565	596	653
0.0011.....	523	559	593	625	685
0.0012.....	546	584	619	653	715
0.0013.....	569	611	645	680	744
0.0014.....	590	631	669	705	772
0.0015.....	611	653	690	730	800
0.0016.....	631	674	715	754	826
0.0017.....	650	695	737	777	851
0.0018.....	669	715	759	800	876
0.0019.....	687	735	780	822	900
0.0020.....	705	754	800	843	923

C	140,000	160,000	180,000	200,000	250,000
0.0001.....	223	238	253	267	298
0.0002.....	315	337	358	377	421
0.0003.....	386	413	438	462	516
0.0004.....	446	477	506	533	596
0.0005.....	499	533	565	596	666
0.0006.....	546	584	619	653	730
0.0007.....	590	631	669	705	789
0.0008.....	631	674	715	754	843
0.0009.....	669	715	759	800	894
0.0010.....	705	754	800	843	942
0.0011.....	740	791	839	884	1,075
0.0012.....	772	826	876	923	1,032
0.0013.....	804	859	912	961	1,075
0.0014.....	834	892	946	997	1,115
0.0015.....	864	923	979	1,032	1,154
0.0016.....	892	954	1,011	1,066	1,192
0.0017.....	920	983	1,042	1,099	1,229
0.0018.....	946	1,011	1,073	1,131	1,264
0.0019.....	972	1,041	1,102	1,162	1,299
0.0020.....	997	1,066	1,131	1,192	1,333

TABLE II—(Continued)

C	300,000	400,000	500,000	600,000	700,000
0.0001.....	326	377	421	462	499
0.0002.....	462	533	596	653	705
0.0003.....	566	653	730	800	864
0.0004.....	653	754	843	923	997
0.0005.....	730	843	942	1,032	1,115
0.0006.....	800	923	1,032	1,131	1,221
0.0007.....	864	997	1,115	1,221	1,320
0.0008.....	923	1,066	1,192	1,306	1,410
0.0009.....	979	1,131	1,264	1,385	1,496
0.0010.....	1,032	1,192	1,333	1,460	1,577
0.0011.....	1,083	1,250	1,398	1,531	1,654
0.0012.....	1,131	1,306	1,460	1,599	1,727
0.0013.....	1,177	1,359	1,520	1,665	1,798
0.0014.....	1,221	1,410	1,577	1,727	1,866
0.0015.....	1,264	1,460	1,632	1,788	1,932
0.0016.....	1,306	1,509	1,686	1,846	1,995
0.0017.....	1,346	1,554	1,737	1,904	2,056
0.0018.....	1,385	1,599	1,788	1,959	2,116
0.0019.....	1,423	1,643	1,837	2,012	2,174
0.0020.....	1,460	1,686	1,885	2,065	2,230

C	800,000	900,000	1,000,000	1,200,000	1,400,000
0.0001.....	533	565	596	653	705
0.0002.....	754	800	843	923	997
0.0003.....	923	979	1,032	1,131	1,221
0.0004.....	1,066	1,131	1,192	1,306	1,410
0.0005.....	1,192	1,264	1,333	1,460	1,577
0.0006.....	1,306	1,385	1,460	1,599	1,727
0.0007.....	1,410	1,496	1,577	1,727	1,866
0.0008.....	1,509	1,599	1,686	1,846	1,995
0.0009.....	1,599	1,696	1,788	1,959	2,116
0.0010.....	1,686	1,788	1,885	2,065	2,230
0.0011.....	1,768	1,875	1,977	2,165	2,339
0.0012.....	1,846	1,959	2,065	2,262	2,443
0.0013.....	1,922	2,039	2,149	2,354	2,543
0.0014.....	1,995	2,116	2,230	2,443	2,639
0.0015.....	2,065	2,190	2,308	2,529	2,732
0.0016.....	2,133	2,262	2,384	2,612	2,821
0.0017.....	2,198	2,332	2,457	2,692	2,908
0.0018.....	2,262	2,399	2,529	2,770	2,992
0.0019.....	2,324	2,465	2,598	2,846	3,074
0.0020.....	2,384	2,529	2,665	2,920	3,154

TABLE II—(Continued)

C	1,600,000	1,800,000	2,000,000	2,500,000	3,000,000
0.0001.....	754	800	843	942	1,032
0.0002.....	1,066	1,131	1,192	1,333	1,460
0.0003.....	1,306	1,385	1,460	1,632	1,788
0.0004.....	1,509	1,599	1,686	1,885	2,065
0.0005.....	1,686	1,788	1,885	2,108	2,308
0.0006.....	1,846	1,959	2,065	2,308	2,529
0.0007.....	1,995	2,116	2,230	2,493	2,732
0.0008.....	2,133	2,262	2,384	2,665	2,920
0.0009.....	2,262	2,399	2,529	2,827	3,097
0.0010.....	2,384	2,529	2,665	2,980	3,264
0.0011.....	2,500	2,652	2,795	3,125	3,424
0.0012.....	2,612	2,770	2,920	3,264	3,576
0.0013.....	2,718	2,883	3,039	3,398	3,722
0.0014.....	2,821	2,992	3,154	3,526	3,863
0.0015.....	2,920	3,097	3,264	3,650	3,998
0.0016.....	3,016	3,199	3,372	3,770	4,129
0.0017.....	3,108	3,297	3,475	3,885	4,256
0.0018.....	3,199	3,392	3,576	3,998	4,379
0.0019.....	3,286	3,485	3,674	4,108	4,500
0.0020.....	3,372	3,576	3,770	4,214	4,617

C	4,000,000	5,000,000	6,000,000	7,000,000	8,000,000
0.0001.....	1,192	1,333	1,460	1,577	1,686
0.0002.....	1,686	1,885	2,065	2,230	2,384
0.0003.....	2,065	2,308	2,529	2,732	2,920
0.0004.....	2,384	2,665	2,920	3,154	3,372
0.0005.....	2,665	2,980	3,264	3,526	3,770
0.0006.....	2,920	3,264	3,578	3,863	4,129
0.0007.....	3,154	3,526	3,863	4,172	4,460
0.0008.....	3,372	3,770	4,129	4,460	4,768
0.0009.....	3,576	4,000	4,379	4,731	5,057
0.0010.....	3,770	4,214	4,617	4,987	5,331
0.0011.....	3,953	4,420	4,842	5,230	5,591
0.0012.....	4,129	4,617	5,057	5,462	5,840
0.0013.....	4,298	4,805	5,264	5,685	6,109
0.0014.....	4,460	4,987	5,462	5,900	6,306
0.0015.....	4,617	5,161	5,654	6,109	6,529
0.0016.....	4,768	5,331	5,840	6,306	6,741
0.0017.....	4,915	5,495	6,020	6,502	6,949
0.0018.....	5,057	5,654	6,192	6,693	7,152
0.0019.....	5,196	5,809	6,365	6,872	7,348
0.0020.....	5,331	5,960	6,529	7,052	7,539

## Design Data

TABLE II—(Continued)

C	9,000,000	10,000,000	12,000,000	14,000,000	16,000,000
0.0001....	1,788	1,885	2,065	2,230	2,384
0.0002....	2,529	2,665	2,920	3,154	3,372
0.0003....	3,097	3,264	3,576	3,863	4,129
0.0004....	3,576	3,770	4,129	4,460	4,768
0.0005....	3,998	4,214	4,617	4,987	5,331
0.0006....	4,379	4,617	5,057	5,462	5,840
0.0007....	4,731	4,987	5,462	5,900	6,306
0.0008....	5,057	5,331	5,840	6,306	6,741
0.0009....	5,364	5,654	6,192	6,693	7,152
0.0010....	5,654	5,960	6,529	7,052	7,539
0.0011....	5,930	6,251	6,848	7,396	7,909
0.0012....	6,192	6,529	7,152	7,724	8,261
0.0013....	6,449	6,796	7,444	8,040	8,594
0.0014....	6,693	7,052	7,724	8,344	8,922
0.0015....	6,902	7,299	7,996	8,637	9,233
0.0016....	7,152	7,539	8,261	8,922	9,536
0.0017....	7,373	7,771	8,511	9,196	9,828
0.0018....	7,587	7,996	8,761	9,459	10,110
0.0019....	7,796	8,215	9,000	9,721	10,410
0.0020....	7,996	8,429	9,230	9,973	10,660

C	18,000,000	20,000,000	25,000,000	30,000,000	40,000,000
0.0001....	2,529	2,665	2,980	3,264	3,770
0.0002....	3,576	3,770	4,214	4,617	5,331
0.0003....	4,379	4,617	5,161	5,659	6,529
0.0004....	5,057	5,331	5,960	6,529	7,539
0.0005....	5,654	5,960	6,663	7,299	8,429
0.0006....	6,192	6,529	7,299	7,996	9,233
0.0007....	6,693	7,052	7,885	8,637	9,973
0.0008....	7,152	7,539	8,429	9,233	10,660
0.0009....	7,587	7,996	8,940	9,794	11,310
0.0010....	7,996	8,429	9,423	10,320	11,920
0.0011....	8,386	8,840	10,750	10,830	12,500
0.0012....	8,761	9,233	10,320	11,310	13,060
0.0013....	9,119	9,611	10,750	11,770	13,590
0.0014....	9,459	9,973	11,150	12,210	14,100
0.0015....	9,794	10,320	11,540	12,640	14,600
0.0016....	10,110	10,660	11,920	13,060	15,090
0.0017....	10,420	10,990	12,290	13,460	15,540
0.0018....	10,730	11,310	12,640	13,850	15,990
0.0019....	11,020	11,620	12,990	14,230	16,430
0.0020....	11,310	11,920	13,330	14,600	16,860

TABLE II—(Continued)

C	50,000,000	60,000,000	70,000,000	80,000,000	90,000,000
0.0001....	4,214	4,617	4,987	5,331	5,654
0.0002....	5,960	6,529	7,052	7,539	7,996
0.0003....	7,299	7,996	8,637	9,233	9,794
0.0004....	8,429	9,233	9,973	10,660	11,310
0.0005....	9,423	10,320	11,150	11,920	12,640
0.0006....	10,320	11,310	12,210	13,060	13,850
0.0007....	11,150	12,210	13,200	14,100	14,960
0.0008....	11,920	13,060	14,100	15,090	15,990
0.0009....	12,640	13,850	14,960	15,990	16,960
0.0010....	13,330	14,600	15,770	16,860	17,880
0.0011....	13,980	15,310	16,540	17,680	18,760
0.0012....	14,600	15,990	17,270	18,460	19,590
0.0013....	15,200	16,650	17,980	19,220	20,390
0.0014....	15,770	17,270	18,660	19,950	21,160
0.0015....	16,320	17,880	19,320	20,650	21,900
0.0016....	16,860	18,460	19,950	21,330	22,620
0.0017....	17,370	19,040	20,560	21,980	23,320
0.0018....	17,880	19,590	21,160	22,620	23,990
0.0019....	18,370	20,120	21,740	23,240	24,650
0.0020....	18,850	20,650	22,300	23,840	25,290

C	100,000,000	120,000,000	140,000,000	160,000,000	180,000,000
0.0001....	5,960	6,529	7,052	7,539	7,996
0.0002....	8,429	9,233	9,973	10,660	11,310
0.0003....	10,320	11,310	12,210	13,060	13,850
0.0004....	11,920	13,060	14,100	15,090	15,990
0.0005....	13,330	14,600	15,770	16,860	17,880
0.0006....	14,600	15,990	17,270	18,460	19,590
0.0007....	15,770	17,270	18,660	19,950	21,160
0.0008....	16,860	18,460	19,950	21,330	22,620
0.0009....	17,880	19,590	21,160	22,620	23,990
0.0010....	18,850	20,650	22,300	23,840	25,290
0.0011....	19,770	21,650	23,390	25,000	26,520
0.0012....	20,650	22,620	24,430	26,120	27,700
0.0013....	21,490	23,540	25,430	27,180	28,830
0.0014....	22,300	24,430	26,390	28,210	29,920
0.0015....	23,080	25,290	27,320	29,200	30,970
0.0016....	23,840	26,120	28,210	30,160	31,990
0.0017....	24,570	26,920	29,080	31,080	32,800
0.0018....	25,290	27,700	29,920	31,990	33,720
0.0019....	25,980	28,460	30,740	32,860	34,850
0.0020....	26,650	29,200	31,540	33,720	35,760



TABLE II—(Continued)

C	200,000,000	250,000,000	300,000,000	400,000,000	500,000,000
0.0001....	8,429	9,423	10,320	11,920	13,330
0.0002....	11,920	13,330	14,600	16,860	18,850
0.0003....	14,600	16,320	17,880	20,650	23,080
0.0004....	16,860	18,850	20,650	23,840	26,650
0.0005....	18,850	21,080	23,080	26,650	29,800
0.0006....	20,650	23,080	25,290	29,200	32,640
0.0007....	22,300	24,930	27,320	31,540	35,260
0.0008....	23,840	26,650	29,200	33,720	37,700
0.0009....	25,290	28,270	30,970	35,760	39,980
0.0010....	26,650	29,800	32,640	37,700	42,140
0.0011....	27,950	31,250	34,240	39,530	44,200
0.0012....	29,200	32,640	35,760	41,290	46,170
0.0013....	30,390	33,980	37,220	42,980	48,050
0.0014....	31,540	35,260	38,630	44,600	49,870
0.0015....	32,640	36,500	39,980	46,170	51,610
0.0016....	33,720	37,700	41,290	47,680	53,310
0.0017....	34,750	38,850	42,560	49,150	54,950
0.0018....	35,760	39,980	43,790	50,570	56,540
0.0019....	36,740	41,080	45,000	51,960	58,090
0.0020....	37,770	42,140	46,170	53,310	59,600

To determine the wave-length resulting from a given combination of inductance and capacity, locate the value of L at the top of the table, and run down the column until opposite the C required.

Wave-length can be calculated by the formula

$$\lambda = 59.6 \sqrt{LC} \quad . . . . . (3)$$

$$\text{or } L = \frac{\lambda^2}{3552 C} \quad . . . . . (4)$$

$$\text{or } C = \frac{\lambda^2}{3552 L} \quad . . . . . (5)$$

**4. FREQUENCY, INDUCTANCE, CAPACITY.**

Frequency, corresponding to given values of L and C, can be found by determining the wave-length, Table 2, and the frequency corresponding to that wave-length, Table 1. Or, if desired, the wave-length can be determined from (3) and the frequency from (1).

5. INDUCTANCE IN CIRCUIT.

Formulas for wave-length are for the total amount of inductance in the circuit. Thus, if inductances are in series or parallel, the resultant value must be found and substituted in the wave-length formula.

**A. Non-coupled inductances in series.** The total L when two or more inductances are in series is the sum

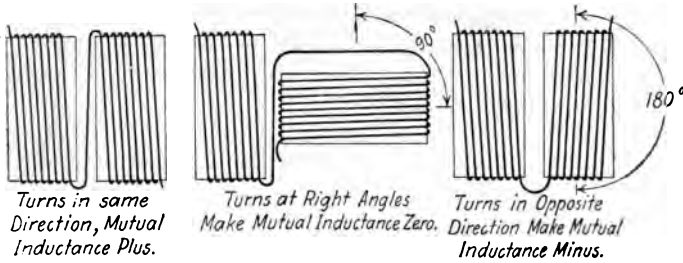

Fig. 1.—Mutual Inductance or Coupling can be Varied by Changing the Relative Position of Two Coils.

of the inductances, if they are not coupled magnetically, or

$$L = L_1 + L_2 + L_3, \text{ etc.} \quad \dots \quad (6)$$

**B. Coupled inductances in series.** Two coupled coils in series, such as the coils of a variometer, give a total inductance, if the coils are aiding, of

$$L = L_1 + L_2 + 2 M, \quad \dots \quad (7)$$

$$\text{or } L = L_1 + L_2 - 2 M, \quad \dots \quad (8)$$

where the coils oppose each other. If connections between the coils are such that the current passes as if through a continuous coil, the coils will be aiding.

**C. Coupled inductances in parallel.** Two coupled coils in parallel, aiding, give a total inductance of

$$L = \frac{L_1 \times L_2 - M^2}{L_1 + L_2 - 2 M} \quad \dots \quad (9)$$

$$\text{or } L = \frac{L_1 \times L_2 - M^2}{L_1 + L_2 + 2 M} \quad \dots \quad (10)$$

when they are opposing.

**D. Non-coupled coils in parallel.** Two coils in parallel, not coupled inductively, give a total inductance.

$$L = \frac{L_1 \times L_2}{L_1 + L_2} \dots \dots \dots (11)$$

**E. Mutual inductance.** Two coupled coils, connected in series or parallel, have a certain value of mutual inductance between them, due to the coupling of the magnetic lines of force, which increases or decreases the total inductance in the circuit, according to whether the coils aid or oppose each other. When two coils are in series, if they are aiding,

$$M = \frac{L - L_1 - L_2}{2} \dots \dots \dots (12)$$

or, opposing,

$$M = \frac{L_1 + L_2 - L}{2} \dots \dots \dots (13)$$

It is very difficult to calculate the mutual inductance between two coils except when they are of the same

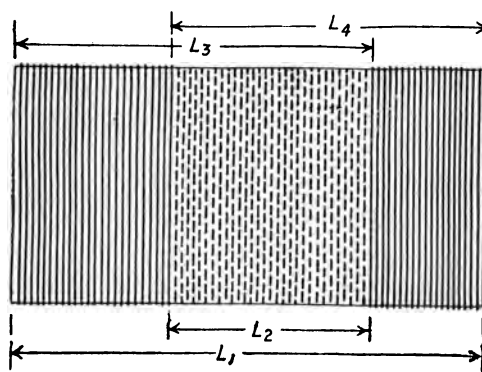

**Fig. 2.—When Calculating the Mutual Inductance of Coils of this Type, it is Considered that a Continuous Winding Separates Them.**

diameter, have the same number of turns per inch, and are coaxial. Fig. 2 illustrates the method. The coils are separated by a distance \$L\_2\$. The inductance \$L\_1\$ is first

calculated as if the winding continued across the separating space.  $L_2$  is calculated as if it were wound with the same number of turns per inch as is used in the coils,  $L_3$  and  $L_4$  and determined in the same manner. Then

$$M = L_1 + L_2 - L_3 - L_4 \dots (14)$$

The change of inductance in a variometer is due to the varying mutual inductance between the coils as their relative positions are varied. Mutual inductance is not considered in designing loose couplers and similar instruments in which the coils are not connected together electrically.

**6. COEFFICIENT OF COUPLING.**

The amount of coupling between the coils, expressed in per cent., is

$$K = \sqrt{\frac{M^2}{L_1 L_2}} \times 100 \dots (15)$$

**F. Measurement of inductance.** The simplest way to measure inductance is to shunt around the coil a cali-

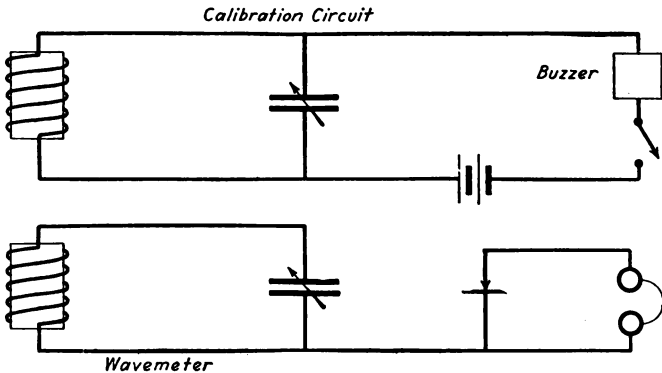

Fig. 3.—Inductance or Capacity can be Measured by Means of this Circuit.

brated condenser, exciting the circuit with a buzzer. When the wave-length of the circuit is measured with a wave-meter, the inductance can be found, knowing the wave-length and capacity of the shunt condenser, by (4). Fig. 3 shows the connections.

**7. CAPACITY IN CIRCUIT.**

As is the case with inductances, wave-length and similar formulas require the total capacity in the circuit. That is, if condensers are in series or parallel, the resultant capacity must be determined and substituted in the formulas.

**A. Condensers in series.** Two condensers of the same capacity, wired in series, give a total capacity of

$$C = \frac{C_1 + C_2}{4} \dots \dots \dots (16)$$

Two condensers of different capacities, in series, give

$$C = \frac{1}{\frac{1}{C_1} + \frac{1}{C_2}} \dots \dots \dots (17)$$

Where there are several different capacities,

$$C = \frac{1}{\frac{1}{C_1} + \frac{1}{C_2} + \frac{1}{C_3}} \dots \dots \dots (18)$$

Table 3 shows the resultant capacity when two condensers of various capacities are in series.

**B. Condensers in parallel.** Two or more condensers in parallel give a resultant capacity equal to the sum of the capacities. That is,

$$C = C_1 + C_2 \dots \dots \dots (19)$$

**C. Distributed capacity.** Because of the difference in potential between the turns of a coil, an inductance possesses a certain amount of local capacity. This distributed capacity acts as a shunt condenser around the coil. However, the value is not considered in designing circuits, nor can it be calculated. In a well-designed inductance, the capacity value can be neglected.

It is important to keep this capacity as low as possible

TABLE III—EFFECTIVE CAPACITY IN mfd

C <sub>tuning</sub>	0.0001	0.0002	0.0003	0.0004	0.0005
0.0001.....	0.000050	0.00006	0.00007	0.00008	0.00008
0.0002.....	0.000060	0.00010	0.00012	0.00013	0.00014
0.0003.....	0.000075	0.00012	0.00015	0.00017	0.00019
0.0004.....	0.000080	0.00013	0.00017	0.00020	0.00022
0.0005.....	0.000083	0.00014	0.00019	0.00022	0.00025
0.0006.....	0.000086	0.00015	0.00020	0.00024	0.00027
0.0007.....	0.000088	0.00015	0.00021	0.00025	0.00029
0.0008.....	0.000089	0.00016	0.00022	0.00026	0.00031
0.0009.....	0.000090	0.00016	0.00023	0.00027	0.00032
0.0010.....	0.000091	0.00017	0.00023	0.00028	0.00033
0.0011.....	0.000092	0.00017	0.00024	0.00029	0.00034
0.0012.....	0.000092	0.00017	0.00024	0.00030	0.00035
0.0013.....	0.000093	0.00017	0.00024	0.00031	0.00036
0.0014.....	0.000093	0.00018	0.00025	0.00031	0.00037
0.0015.....	0.000094	0.00018	0.00025	0.00032	0.00038
0.0016.....	0.000094	0.00018	0.00025	0.00032	0.00039
0.0017.....	0.000094	0.00018	0.00026	0.00032	0.00039
0.0018.....	0.000095	0.00018	0.00026	0.00033	0.00040
0.0019.....	0.000095	0.00018	0.00026	0.00033	0.00040
0.0020.....	0.000095	0.00018	0.00026	0.00033	0.00040

C <sub>tuning</sub>	0.0006	0.0007	0.0008	0.0009	0.0010
0.0001.....	0.00009	0.00009	0.00009	0.00009	0.00009
0.0002.....	0.00015	0.00015	0.00016	0.00016	0.00017
0.0003.....	0.00020	0.00021	0.00022	0.00023	0.00023
0.0004.....	0.00024	0.00025	0.00026	0.00027	0.00028
0.0005.....	0.00027	0.00029	0.00030	0.00032	0.00033
0.0006.....	0.00030	0.00032	0.00034	0.00036	0.00038
0.0007.....	0.00032	0.00035	0.00037	0.00039	0.00041
0.0008.....	0.00034	0.00037	0.00040	0.00042	0.00044
0.0009.....	0.00036	0.00039	0.00042	0.00045	0.00047
0.0010.....	0.00038	0.00041	0.00044	0.00047	0.00050
0.0011.....	0.00039	0.00043	0.00046	0.00049	0.00053
0.0012.....	0.00040	0.00044	0.00048	0.00051	0.00055
0.0013.....	0.00041	0.00045	0.00050	0.00053	0.00057
0.0014.....	0.00042	0.00046	0.00051	0.00055	0.00058
0.0015.....	0.00043	0.00047	0.00052	0.00057	0.00060
0.0016.....	0.00044	0.00048	0.00053	0.00058	0.00061
0.0017.....	0.00044	0.00049	0.00054	0.00059	0.00063
0.0018.....	0.00045	0.00050	0.00055	0.00060	0.00064
0.0019.....	0.00045	0.00051	0.00056	0.00061	0.00065
0.0020.....	0.00046	0.00052	0.00057	0.00062	0.00066

as it causes a reduction of the signal strength and makes the tuning broad.

**D. Measurement of capacity.** Capacity can be measured in a manner similar to that in Section 5 F, except that a standard inductance is used instead of a calibrated condenser. Then the capacity of the condenser is given by (5).

## CHAPTER II

### RADIO ANTENNAS

The present-day developments of radio telegraph has made it possible to obtain some results with almost anything for an antenna, from tin cans to wire fences, or even with no antenna at all. The radio experimenters, however, are interested in more practical devices than bed-spring or tree antennas.

Radio antennas are generally divided into three classes, antennas, or structures of elevated wires, loop antennas, or coils not connected to the ground, and condenser antennas, made up of elevated plates, not grounded.

In making antenna circuit calculations, only the capacity of the antenna or condenser antenna is considered, while in the loop, only the inductance is considered.

#### 8. ANTENNAS.

**A. Single-wire types.** The long, low, single wire is the best for receiving, though it is not as efficient for sending as the multi-wire types. Three sizes which have been standardized by the General Apparatus Company are 30 feet high at each end, and 100, 200 and 300 feet long, known as the short, long, and super-range types.

The short-range size is for 200-meter reception. The average capacity is 0.0002 mfd.

A long-range antenna is for receiving commercial stations up to 5,000 meters, although greater wave-lengths can be received by the use of large loading coils. The capacity is generally 0.0004 mfd.

The super-range type is intended for long-wave reception over great distances. Its capacity is approximately 0.0005 mfd.



**B. V Types.** Particularly for portable work, the United States Signal Corps has employed two wires stretched out at an angle of  $60^\circ$ . Such an antenna with wires 100 feet long, 20 feet above the ground, has a capacity of about 0.0004 mfd. and gives good results.

**C. Multi-wire types.** Although single-wire antennas can be used for sending, several horizontal wires give better results. The General Apparatus Company has adopted as a standard 200-meter antenna four wires 2 feet apart, 80 feet long, and 30 feet high at both ends. The capacity is approximately 0.0005 mfd.

It makes very little difference whether the lead-in is brought from the center or end. When the antenna is erected on the roof of an apartment house, the height is taken as the elevation above the roof.

**D. Umbrella types.** Essentially the umbrella type antenna is made of a wooden or metal mast, the wires of which form the antenna. If the mast is wooden, the wires are connected together near the ground, or if it is metal, the wires are connected to the mast. Galvanized iron drain pipe is often used for a mast as it is so light and easy to handle, yet sufficiently strong for moderate-size aerials. Oftentimes it is possible to mount the mast on the ridge pole of a house, running the wires to the ends of the ridge pole and to gables.

This type is good for transmitting and receiving.

## 9. LOOP ANTENNAS.

The loop antenna, consisting of a coil or flat spiral, is used extensively for an indoor aerial, for direction finding, and for cutting down interference. While to equal the receiving or transmitting range of an antenna, it must approach the latter in size, very long distance work can be accomplished with an amplifier and even with a single audion if the signals are from a high-powered station.

**A. Square-cage loop.** The inductance of a square-cage loop can be determined with sufficient accuracy for design

purposes by the use of formula (27), in which the radius  $r$ , is taken as

$$r = \frac{\text{Length of one side} \times 1.2}{2} \quad . \quad . \quad . \quad (20)$$

and diameter,  $d$ , as

$$d = \text{length of one side} \times 1.2 \quad . \quad . \quad . \quad (21)$$

The other terms of equation (27) can be applied directly to the dimensions of the loop.

**B. Square flat loop.** Formula (27) can be used for the approximate inductance of a square flat loop by substituting the average radius for  $r$ ,

$$r = \frac{\text{av. length of outer and inner side} \times 1.2}{2} \quad . \quad (22)$$

the average diameter for  $d$ ,

$$d = \text{av. length of outer and inner sides} \times 1.2 \quad . \quad (23)$$

the length,  $l$ , as

$$l = \frac{\text{outer side} - \text{inner side}}{2} \quad . \quad . \quad . \quad (24)$$

and the turns per inch, measured at right angles to one of the sides, for  $n$ .

**C. Leads.** Connections to a loop antenna must be as short as possible, and arranged in such a way that there is no inductance or capacity effect to other conductors or grounded metal bodies.

**D. Capacity in loops.** Distributed capacity in loop antennas causes a broadening of the tuning. Every effort must be made, therefore, to keep the insulation of maximum value. Bare wire is generally used for the winding so that there will not be losses in the insulation. Bakelite supports, which do not absorb moisture, are necessary to support the wire. As an added precaution, corrugations or slots may be made between the grooves holding the wire. Loops should be mounted indoors, so that no moisture or dust will collect on the supports.

**E. Directional distortion.** Metal objects distort the radio waves, introducing errors in the directional indications. Also, loops set up near the water are inaccurate.

As the distortion varies at different wave-lengths, correction tables must be made at different wave-lengths.

#### 10. CONDENSER ANTENNAS.

Very little work has been done, up to the present time, on condenser antennas, so that no data is available. Antennas made up of two horizontal net works of wire, one over the other, both insulated from the ground, were used early in radio work. The recent developments are in the form of plates or copper screens, one acting as the antenna, and the other as the ground. The condenser is charged by the radio waves, discharging into the apparatus, in the case of a receiver, or conversely in the case of a transmitter.

**A. Experimental types.** Experiments with small condenser antennas have shown them equal for receiving purposes to a small loop. Plates have been used made of fine-mesh copper screen 10 feet square, separated 10 or 12 inches. They were thoroughly insulated from the ground and from each other.

#### 11. AIRPLANE ANTENNAS.

Airplane antennas are generally in the form of one or more trailing wires, with the stay wires and engine acting as the ground. Antennas erected laterally on the upper plane, or types having a short mast, have proved inefficient because of their low capacity and radiation resistance.

**A. Single trailing wire.** The following data was taken with a single stranded cable trailing from lower wing, at the first rib from the left of the fuselage of a Curtiss JN machine flying at an altitude of 2,000 feet.

Length of Wire	Capacity in mfd.	Natural $\lambda$ in Meters
100 ft.	0.000185	165
150	0.000205	185
200	0.000225	215
300	0.000260	275
400	0.000290	350
500	0.000305	435
600	0.000315	525

Under the same conditions, these resistance measurements were taken. The values are the total resistance of the antenna, and not simply the radiation resistance.

Length of Wire Feet	OHMS					
	250 λ	300 λ	400 λ	500 λ	600 λ	900 λ
100.....	2.0	1.0	0.6	....	....	...
200.....	10.3	6.0	3.6	2.4	1.1	...
300.....	...	...	8.5	5.2	3.6	2.0
400.....	...	...	...	11.0	7.0	3.6
500.....	...	...	...	....	12.3	5.6
600.....	...	...	...	....	....	7.8

The directive effect of a single trailing wire is shown by the data below. It will be noted that there is a slight distortion to the left, the side on which the antenna was fastened. The antenna was 500 feet long, and the measurements were taken under the conditions just described. The values of received energy represent the relative signal strength at a station one mile from the airplane.

Direction	Received Energy
Dead ahead	190
30° left ahead	205
60° left ahead	200
90° left	105
120° left astern	20
150° left astern	5
Dead astern	8
30° right ahead	165
60° right ahead	130
90° right	80
120° right astern	33
150° right	13

**B. Two trailing wires.** Greater efficiency has been obtained with two trailing wires, fastened to the struts of the machine, but broken by insulators 5 feet from the struts. Leads are brought off at the insulators to the fuselage. The wires and engine were used as a ground.

In a series of tests with 40-foot, 50-foot, and 60-foot wires attached to the outer struts, the natural wavelength was found to be 65, 73, and 80 meters, with a re-

sistance at 100 meters of 2.3, 3.5, and 8.0 ohms respectively. When fastened to the inner struts the wave-length was 58, 70, and 77 meters, with a resistance of 2.25, 3.75, and 4 ohms respectively.

Means were not at hand to measure the capacity, but it was found that capacity was less when the wires were secured to the inner struts. In the latter case, a variation of capacity was noted when the machine was ascending or descending steeply, probably due to the change in the relative position of the antenna wires and stay wires.

The transmission ahead was approximately two times as good as astern.

## 12. ANTENNA RESISTANCE.

Like all other circuits, an antenna circuit contains a certain amount of resistance. There is a useful resistance, called radiation resistance, and a wasteful resistance, which must be kept as low as possible, due to losses in the circuit.

**A. Components of the antenna resistance.** The resistance of an antenna is due to

1. Useful
  - (a) Loss of energy radiated as radio signals.
2. Wasteful
  - (a) Loss of energy in resistance of ground connections.
  - (b) Poor insulation.
  - (c) Corona discharges from overloaded antenna.
  - (d) Dielectric absorption.
  - (e) Absorption from near-by structures.
  - (f) Loss in resistance of conductors.

**B. Antenna resistance.** The resistance of an antenna is equal to the resistance of a non-inductive circuit which will absorb the same amount of power. This value can be measured readily.

**C. Radiation resistance.** The radiation resistance is equal to the resistance of a non-inductive circuit which

will absorb the same amount of power as is radiated by the antenna in radio signals.

**D. Ground resistance.** The resistance of the ground connection and conductors is practically constant at varying frequencies.

**E. Dielectric Absorption.** Power losses from dielectric absorption increase with the wave-length. If the wave-length reaches the natural period of a near-by structure, there will be a decided hump in the resistance wave-length curve.

**F. Static capacity.** The capacity of an antenna, with no apparatus connected, is called the static capacity. This is the value of capacity used in designing antenna circuits.

**G. Natural wave-length.** Since an antenna possesses inductance and capacity, it will oscillate at the corresponding wave-length, known as the natural wave-length, when it is excited by auxiliary means.

**H. Test data.** The following measurements were made on a 60° V type antenna 30 feet high, with each leg 100 feet long. An inductance in series with the antenna and ground was varied to increase the length of the radiated waves.

Natural  $\lambda$ , 230 meters.

Static capacity 0.000345 mfd.

It should be noted that the useful resistance is greatest

$\lambda$ in meters	Radiation Resistance	Absorption Resistance	Ground Resistance	Total Antenna Resistance
250 . . . . .	36.0	2.0	5.0	43.0
300 . . . . .	26.0	3.0	5.0	34.0
350 . . . . .	19.5	3.5	5.0	28.0
400 . . . . .	15.0	4.0	5.0	24.0
500 . . . . .	10.0	5.5	5.5	21.0
600 . . . . .	6.5	6.5	6.5	19.5
700 . . . . .	5.0	8.0	6.5	19.5
800 . . . . .	3.5	8.0	7.0	19.5
900 . . . . .	2.5	10.5	7.0	20.0
1,000 . . . . .	2.0	11.5	7.5	21.0
1,200 . . . . .	2.0	14.0	8.0	24.0

when the least loading is used in the antenna circuit. Also, that the total resistance rises rapidly beyond a certain loading point without increasing the radiation resistance.

**I. Measurement of antenna resistance.** Fig. 4 shows a circuit used in measuring antenna resistance. The secondary of the oscillation transformer can be connected either to the antenna and ground or to a non-inductive resistance and a variable air-condenser.

The condenser should be adjusted to a value equal to the static capacity of the antenna. First, the antenna

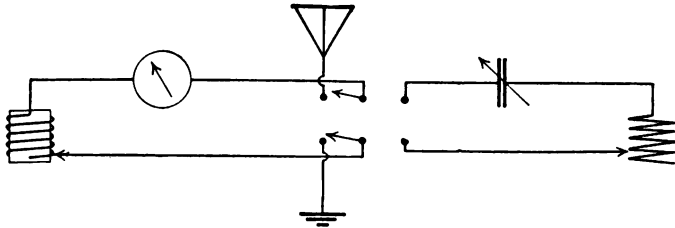

**Fig. 4.**—To Measure the Resistance of an Antenna, the Later is Replaced by a Dummy Circuit.

is connected, and a reading taken on the hot-wire ammeter. Then the switch is thrown to the dummy antenna, and the non-inductive resistance varied until the ammeter is at the position previously determined. The direct current resistance of the resistor will then be equal to the resistance of the antenna.

**J. Errors.** If possible, this measurement should be made with a vacuum tube oscillator in order that low voltages can be used. This will reduce the likelihood of losses in the dummy air condenser, resulting in too low an indication of the antenna resistance.

The non-inductive resistance must be made of non-magnetic wire, wound back and forth over bakelite strips, with the adjacent wires as close as possible to neutralize the inductance of the wires. The antenna resistance

reading will be low if there is appreciable inductance in the resistor.

**13. ANTENNA CAPACITY.**

The capacity of an antenna is due to the condenser effect between the elevated wires and the earth, which act as two plates, insulated by the atmosphere.

**A. Measurement of antenna capacity.** Fig. 5 gives the circuit used to measure the capacity of an antenna. This method requires only a calibrated condenser.

The switch is thrown to the antenna, and the signals from the buzzer are tuned in at the coupled detector

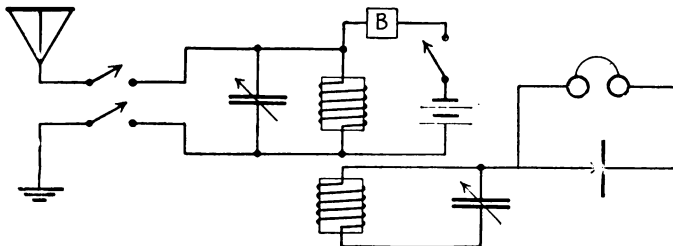

**Fig. 5.—Diagram of Apparatus for Measuring Antenna Capacity.**

circuit. Then the switch is opened, disconnecting the antenna. Without touching the detector circuit adjustment, the calibrated condenser is varied until the signals come in again at maximum intensity. The amount of increase in capacity equals the capacity of the antenna.

**B. Errors.** This method does not take into consideration the inductance of the antenna which, however, is very small compared to the capacity. Therefore, the reading is slightly high. It can be applied to antennas or condenser antennas, but not to loops.

**C. Exact measurement of antenna capacity.** The actual capacity can be determined by the formula

$$C = \frac{\lambda_1^2 - \lambda_2^2}{\lambda_2^2} \times C_1 \quad . . . . (25)$$

A small inductance is connected in series with the antenna



and ground, with a buzzer around the coil, Fig. 6. The wave-length of the circuit is measured, giving a value  $\lambda_1$ . Then a series condenser of known capacity,  $C_1$ , is inserted, and the wave-length taken again,  $\lambda_2$ .  $C$ , the capacity of the antenna, is determined by substituting and solving (25).

#### 14. ANTENNA INDUCTANCE.

The inductance of a loop antenna can be determined with sufficient accuracy for practical purposes from the

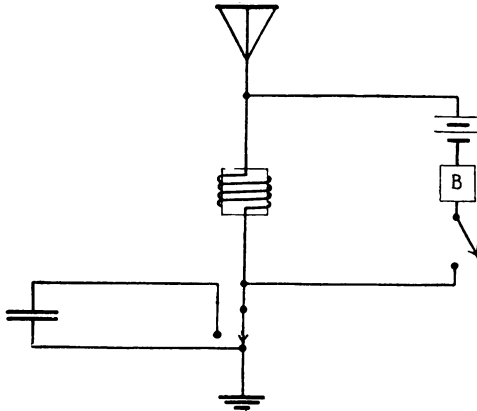

Fig. 6.—A More Exact Method of Determining the Capacity of an Antenna.

formulas in Section 9. Measurements of inductance can be made with the circuit in Fig. 6, using a known inductance in place of the condenser.

$$L = \frac{\lambda_1^2}{\lambda_2^2 - \lambda_1^2} \times L_1 \quad . . . . (26)$$

The wave-length  $\lambda_1$ , without the known inductance, is first measured, then, with the known inductance  $L_1$  cut in, the new wave-length,  $\lambda_2$ , is measured.  $L$ , the inductance of the antenna, is determined by substituting and solving (26).

## PART II

### RECEIVING EQUIPMENT

#### CHAPTER III

#### DESIGN OF INDUCTANCES

##### 15. LOSSES IN INDUCTANCES.

If an audion detector is to be used for receiving, every means must be employed to maintain a high voltage across the coils.

**A. Distributed capacity.** Distributed capacity is due to the difference in potential between the turns, while the losses occur in the dielectric between the turns and are also due the shunt condenser action of the capacity. Colored covering introduces losses; use uncolored wire. Shellac absorbs moisture; use Sterling insulating varnish, or better, G-A-lectric varnish to keep the wires in place. Cardboard or fiber tubing absorb moisture and introduce losses; use hard rubber or G-A-lite tubing. The larger the diameter of the coil, the greater the difference in potential between the turns. The capacity of the coil also served to increase its effective resistance.

One of the best ways to wind a coil is to use bare wire wound over a circular cage of hard rubber strips, though this method is seldom practical. Another method is to use bare wire spaced with thread, removing the thread when the coil is wound. A coat of G-A-lectric will keep the wires in place. If taps are to be taken off, the wire can be run, at those points, over a 1-inch length of Empire tubing cut in half lengthwise. Soldering can be done

when the coil is wound and varnished. Distributed capacity weakens the signals, and makes the tuning broad.

**B. High frequency resistance.** Conductors carrying currents of radio frequency offer a higher resistance than to direct currents, due to the localization of the current in the conductors, generally known as skin effect. On a straight wire, the current travels near the surface, instead of permeating the entire cross-section. When the wire is curved, the current is on the inside of the circle. Because of the diminished area of the path, the resistance is increased.

The effect of increasing the resistance is to make the signals weaker, and to broaden the tuning.

High frequency cable is used on all high-grade receiving apparatus to keep down the resistance. It should be remembered, however, that merely making up a cable of enameled wires does not reduce the resistance. Imperfect insulation between the wires, such as break in the enamel, causes losses. Inferior covering over the wires makes trouble.

The standard high frequency cables are 10-No. 38, 20-No. 38 and 3 x 16-No. 38. The 10-38 is for coils in which space is an important factor. It can be made into banked windings of 2 or 3 layers. 20-30 is most widely used. Banked windings of several layers can be made with it. 3 x 16-38 is made of 16 cables of three twisted wires all twisted together. This is the best, as it distributes each wire evenly throughout the cross section. The outside covering of all these cables should be of two layers of unbleached silk.

Tests made on coils having iron, copper, or brass in the magnetic field show that the resistance is greatly increased, and, contrary to the general opinion, brass and copper cause a loss practically as great as iron. Therefore, in designing coil supports and controls, the metal parts should be kept as far away from the inductances as possible.

TABLE IV

Values of K for Use in Formulas (27), (28)

Diameter Length	K	Diameter Length	K	Diameter Length	K
0.00	1.0000	2.00	0.5255	7.00	0.2584
.05	.9791	2.10	.5137	7.20	.2537
.10	.9588	2.20	.5025	7.40	.2491
.15	.9391	2.30	.4918	7.60	.2448
.20	.9201	2.40	.4816	7.80	.2406
0.25	0.9016	2.50	0.4719	8.00	0.2366
.30	.8838	2.60	.4626	8.50	.2272
.35	.8665	2.70	.4537	9.00	.2185
.40	.8499	2.80	.4452	9.50	.2106
.45	.8337	2.90	.4370	10.00	.2033
0.50	0.8181	3.00	0.4292	10.00	0.2033
.55	.8031	3.10	.4217	11.00	.1903
.60	.7885	3.20	.4145	12.00	.1790
.65	.7745	3.30	.4075	13.00	.1692
.70	.7609	3.40	.4008	14.00	.1605
0.75	0.7478	3.50	0.3944	15.00	0.1527
.80	.7351	3.60	.3882	16.00	.1457
.85	.7228	3.70	.3822	17.00	.1394
.90	.7110	3.80	.3764	18.00	.1336
.95	.6995	3.90	.3708	19.00	.1284
1.00	0.6884	4.00	0.3654	20.00	0.1236
1.05	.6777	4.10	.3602	22.00	.1151
1.10	.6673	4.20	.3551	24.00	.1078
1.15	.6573	4.30	.3502	26.00	.1015
1.20	.6475	4.40	.3455	28.00	.0959
1.25	0.6381	4.50	0.3409	30.00	0.0910
1.30	.6290	4.60	.3364	35.00	.0808
1.35	.6201	4.70	.3321	40.00	.0728
1.40	.6115	4.80	.3279	45.00	.0664
1.45	.6031	4.90	.3238	50.00	.0611
1.50	0.5950	5.00	0.3198	60.00	0.0528
1.55	.5871	5.20	.3122	70.00	.0467
1.60	.5795	5.40	.3050	80.00	.0419
1.65	.5721	5.60	.2981	90.00	.0381
1.70	.5649	5.80	.2916	100.00	.0350
1.75	0.5579	6.00	0.2854	.....	.....
1.80	.5511	6.20	.2795	.....	.....
1.85	.5444	6.40	.2739	.....	.....
1.90	.5379	6.60	.2685	.....	.....
1.95	.5316	6.80	.2633	.....	.....

## 16. SINGLE LAYER SOLENOIDS.

The single layer solenoid, wound on a tube of circular cross section, is the most common type used in radio work.

**A. Inductance.** The inductance can be determined by

$$L = 100.2 n^2 r^2 l k \quad . . . . (27)$$

where  $k$  is a factor determined by the ratio of the diameter to the length, found in Table IV. If the diameter, length, and inductance are known, then the turns per inch required are

$$n = \sqrt{\frac{L}{100.2 r^2 l k}} \quad . . . . . (28)$$

Table V shows the turns per inch of wire having different kinds of insulation, and Table VI, the feet per pound.

TABLE V

Turns per Inch of Copper Wire with Various Insulations

B. & S. Gauge	Enamel	Single Cotton	Double Cotton	Single Silk	Double Silk	Cotton Enamel	Silk Enamel
18. . . . .	23	21	19	23	22	20	22
19. . . . .	26	24	21	26	24	23	24
20. . . . .	29	26	23	29	27	25	27
21. . . . .	32	29	25	32	30	27	30
22. . . . .	37	33	29	36	33	31	34
23. . . . .	41	37	32	40	37	34	37
24. . . . .	46	40	34	44	41	38	42
25. . . . .	51	44	37	49	45	42	46
26. . . . .	57	48	41	54	50	46	51
27. . . . .	64	54	44	60	54	50	57
28. . . . .	74	59	47	67	60	55	63
29. . . . .	80	64	50	74	65	60	69
30. . . . .	90	70	54	82	71	65	76
31. . . . .	101	75	57	90	77	71	84
32. . . . .	112	82	60	99	83	77	92
33. . . . .	127	88	64	108	90	83	101
34. . . . .	141	95	67	119	97	89	110
35. . . . .	158	101	71	129	104	95	120
36. . . . .	178	108	74	140	111	102	131

10-38 H. F. Cable, 45 turns per inch.

20-38 H. F. Cable, 40 turns per inch.

3 x 16-38 H. F. Cable, 20 turns per inch.

The number of feet required to wind a coil is

$$\text{feet of wire} = 0.2619 d l n \dots (29)$$

Complete data for the length, diameter and inductance is given in Inductance Tables, by M. B. Sleeper.

**17. BANK WOUND COILS.**

Where space limitations require shorter coils than can be made with a single layer coil, bank winding can be used. The method is indicated below.

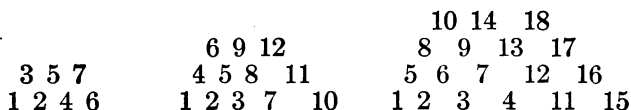

The two bank coil is started by winding two complete turns on the coil, then jumping the wire up between the first and second for another turn, down again, up, and so

**TABLE VI**  
Feet per Pound of Copper Wire with Various Insulations

B. & S. Gauge	Enamel	Single Cotton	Double Cotton	Single Silk	Double Silk	Cotton Enamel	Silk Enamel
18.....	200	196	189	201	199	196	202
19.....	253	246	237	255	252	242	248
20.....	320	311	298	324	319	307	315
21.....	404	387	370	400	389	380	394
22.....	509	488	401	501	493	479	497
23.....	642	612	584	632	631	600	622
24.....	810	763	745	799	779	750	781
25.....	1019	953	903	1008	966	933	982
26.....	1286	1201	1118	1263	1202	1166	1232
27.....	1620	1500	1422	1584	1543	1457	1548
28.....	2042	1860	1759	1988	1917	1824	1946
29.....	2570	2370	2207	2520	2485	2288	2433
30.....	3218	2860	2529	3165	3009	2810	3031
31.....	4082	3482	2768	3933	3683	3473	3793
32.....	5132	4234	3737	4913	4654	4267	4737
33.....	6445	5141	4697	6129	5689	5267	5956
34.....	8093	6317	6168	7646	7111	6461	7427
35.....	10,197	7755	6737	9680	8856	7835	9207
36.....	12,890	9511	7877	12,162	10,869	9437	11,485

on. The same principle is followed out in coils of a greater number of banks. By this method, the distributed capacity is made lower than if the coil were of several horizontal layers.

Banked windings are sometimes made as high as 8 or 10, though the capacity is increased greatly with more than 3 or 4 layers. High frequency cable and small solid wires can be banked most easily, although it takes considerable practice for one who is not familiar with the process. The work can be facilitated by using a blunt screw-driver to make the bends in the wire.

**A. Inductance.** The inductance can be determined closely by (27) using the average diameter of the winding for  $d$ , and the total number of turns per inch for  $n$ . That is,  $n$  would be the product of the turns per inch of the wire and the number of layers.

### 18. FIGURE EIGHT COILS.

Figure eight coils are used as variometers or coupling coils where space is limited. To vary the coupling, the coils are placed end to end, and one coil turned axially. It will be seen that a figure eight coil is made up of two semi-circular coils with their flat sides together. If, in a variometer, the two sets of coils are similarly placed and aiding, the inductance is maximum. Turned  $90^\circ$ , with the straight sides at right angles, the mutual inductance is 0. At  $90^\circ$  more, the coils will be similarly placed but opposing, giving a minimum inductance. Used as coupling coils, it is only necessary to turn one coil  $90^\circ$  to change from maximum to minimum coupling.

To wind a figure eight coil, start at the inside of the slot, wind around the tube to the other side of the slot, through the slot, and around the tube in the opposite direction. It is not advisable to have a part of the coil of circular winding and part figure eight, as this introduces high frequency losses in the circular part. There is no advantage in making a figure eight coil more than

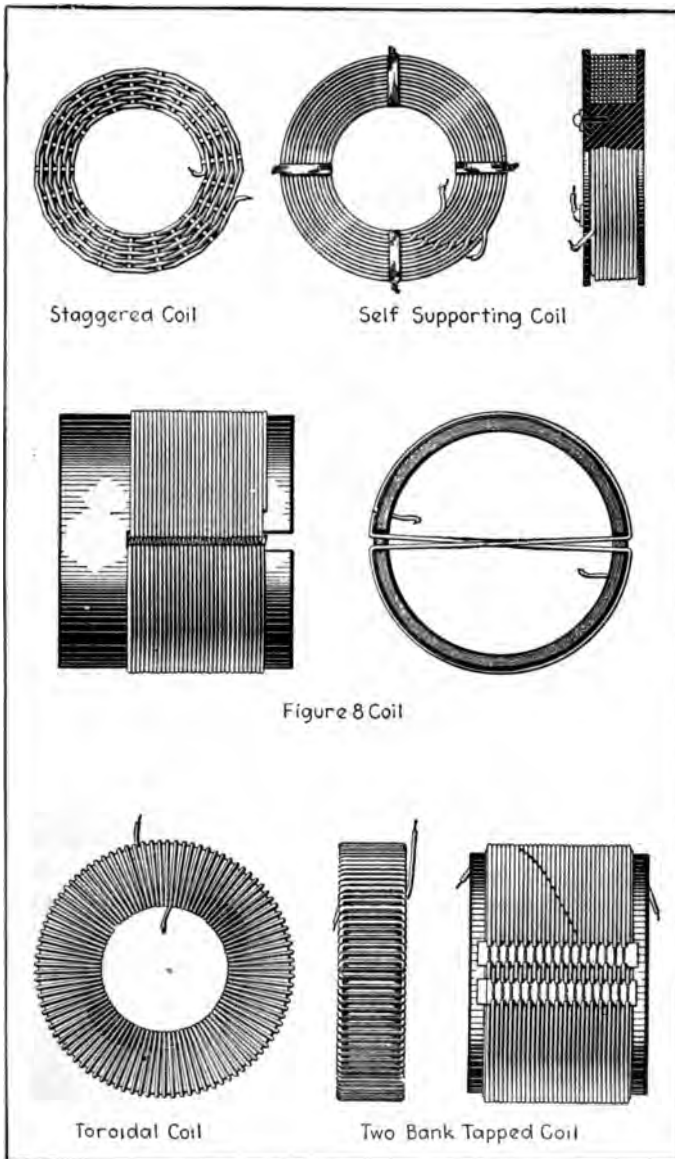

**Fig. 7.—Illustrating Some of the Methods by which Coils are Wound.**



2 inches long, as the mutual inductance between the outer turns would be negligible.

**A. Inductance.** Inductance of a figure eight coil is given by

$$L = L_1 k \quad . . . . . (30)$$

where  $k$  is a constant taken from Table VII. The value

TABLE VII  
Constant  $k$  for formula (30)

Length Diameter	K	Length Diameter	K	Length Diameter	K
0.02	1.550	0.20	1.550	0.30	1.465
0.04	1.550	0.22	1.550	0.31	1.450
0.06	1.550	0.23	1.545	0.32	1.435
0.08	1.550	0.24	1.540	0.33	1.420
0.10	1.550	0.25	1.530	0.34	1.400
0.12	1.550	0.24	1.520	0.35	1.383
0.14	1.550	0.27	1.510	0.36	1.366
0.16	1.550	0.28	1.495	0.37	1.348
0.18	1.550	0.29	1.480	0.38	1.330

of  $L_1$  is determined as if it were a single layer solenoid, from (27).

**19. MULTILAYER COILS.**

There is a right and wrong way to wind multilayer coils as indicated below.

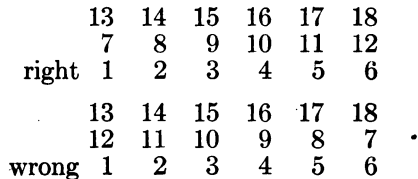

In the correct method, each layer is started on the same side of the coil, with the result that the maximum potential between turns is, in this example, due to a difference of 6 turns, while in the wrong method, it is 12 turns. Some of the United States Navy equipment employs coils.

wound in this way, with a layer of paper between each layer of wire.

**A. Inductance.** The inductance of a multilayer coil can be determined by the formula.

$$L = \frac{31.90 n^2 \text{ total } r^2 \text{ av.}}{0.23 r \text{ av.} + 0.44 l + 0.39 w} \quad (31)$$

The average radius is

$$r \text{ av.} = \frac{\text{outside diam.} + \text{inside diam.}}{4} \quad (31a)$$

and the radial depth,

$$w = \frac{\text{outside diam.} - \text{inside diam.}}{2} \quad (31b)$$

To find the total number of turns required for a multilayer coil, knowing the required inductance, the length, the average diameter and radial depth.

$$n \text{ total} = \sqrt{\frac{L (0.23 r \text{ av.} + 0.44 l + 0.39 w)}{31.9 r^2 \text{ av.}}} \quad (32)$$

Then the turns per inch of wire to give the proper number of total turns, according to the required length and radial depth, is

$$t. p. i. = \sqrt{\frac{n \text{ total}}{l w}} \quad (33)$$

### 20. TOROIDAL COILS.

Toroidal coils are wound on closed rings of rectangular round cross section. They present the advantage of having no external field. The only way that coupling to a torus can be effected is by putting several turns directly over the coil winding. Conductors wound around the ring or placed beside the ring coaxially produce no coupling effect.

A needle, consisting of a brass or wooden strip, about 12 inches long, notched at the ends, is used to wind torii. The wire is first wound onto the needle. Then the needle can be passed readily through the center of the ring.

**A. Inductance.** Formula (34) gives the inductance of a torus of circular cross-section.

$$L = 12.57 n^2 \left( 2.54 r_a - \sqrt{2.54 r_a - 2.54 r_b} \right) \quad (34)$$

The inductance of a torus of rectangular cross-section is

$$L = 4.606 n^2 l_a \log_{10} \frac{r_{\text{outer}}}{r_{\text{inner}}} \quad (35)$$

The number of turns which can be wound in a single layer on a torus is

$$n_{\text{total}} = 3.1416 d_{\text{inner}} t. p. i. \quad (36)$$

To obtain the maximum inductance, a torus should have a large cross-sectional area, rather than a large outside diameter.

### 21. STAGGERED COILS.

Where a self-supporting coil is required, the staggered winding is often employed. This type of coil is made on a removable core, in which an odd number of pins are set radially. The wire is woven back and forth on the pins. Sometimes two rows of pins are used, making it possible to get a greater inductance with no increase in diameter over a single row coil.

There is no formula for calculating the inductance of these coils, as too many varying factors enter in to their design.

### 22. VARIATION OF COUPLING.

There is a great variety of ways to vary the coupling between two coils, the particular one of which should be selected according to the design and space requirements. It should be remembered, in designing the coil supports, that any metal in the magnetic field increases the high frequency resistance of the winding.

**A. Coaxial in and out type.** The coils are mounted coaxially, with one stationary and the other movable toward or from the first. This is applicable to

Solenoids	Multilayer and
Pancake	Staggered coils

Various methods of effecting the movement are given in Fig. 8.

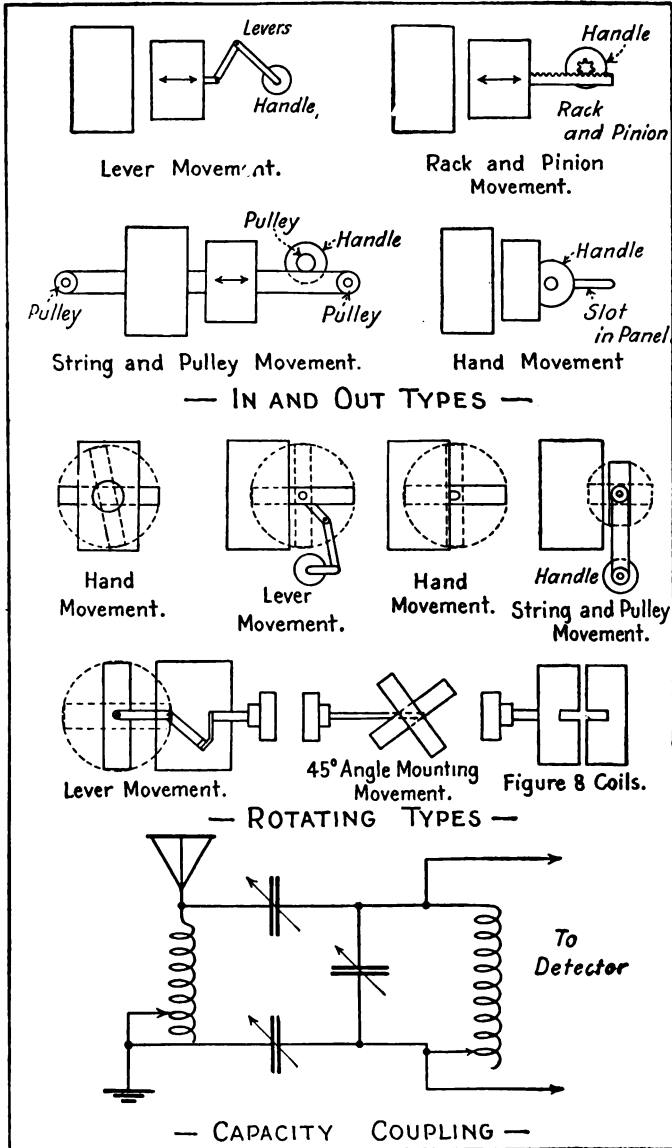
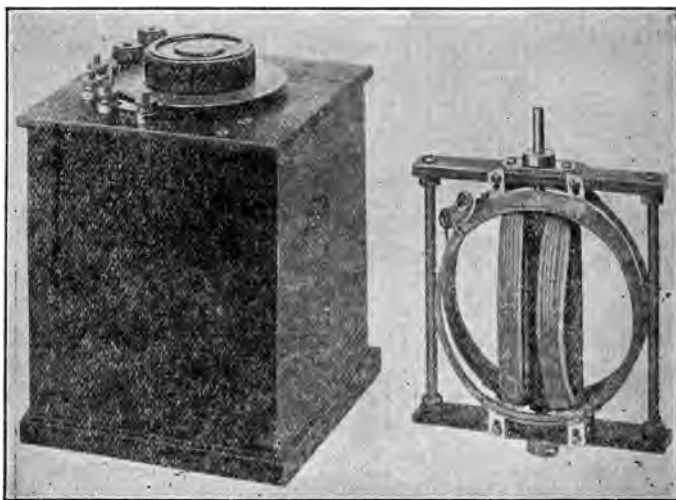

Fig. 8.—Various Ways in which the Coupling between Two Coils can be Varied.

**B. Rotating Types.** A number of ways to vary inductance by rotating one coil are given in Fig. 8. The coils can be wound on cylindrical or spherical forms. They can be separated considerably at maximum coupling, for very tight coupling is not essential. The coefficient of coupling need not exceed 5%.

**C. Capacity coupling.** There is also an electrical method of coupling sometimes used, though offering small advantage. This is done by interposing two condensers,



**Fig. 9.—A General Radio Variometer with Self-supporting Coils.**

operated by the same handle, between the primary and secondary coils. Coupling is maximum at maximum capacity. The condenser should be of 0.0005 mfd. each.

The wave-length to which the primary and secondary circuits are tuned is not controlled by the coupling condensers.

### **23. VARIATION OF INDUCTANCE**

Inductance can be varied by changing the self-inductance of one coil or by varying the mutual inductance between two coils.

**A. Variation of mutual inductance.** Any of the methods in Fig. 8, except the capacity coupling, can be employed by connecting the coils in series or parallel. Resulting effective inductance is given by the formulas in Section 5. It is necessary to have the coils as close together as possible in order to obtain a large variation. When the planes of the windings are at right angles, the mutual inductance is  $O$ .

**B. Sliders.** Sliding contacts for radio coils are not

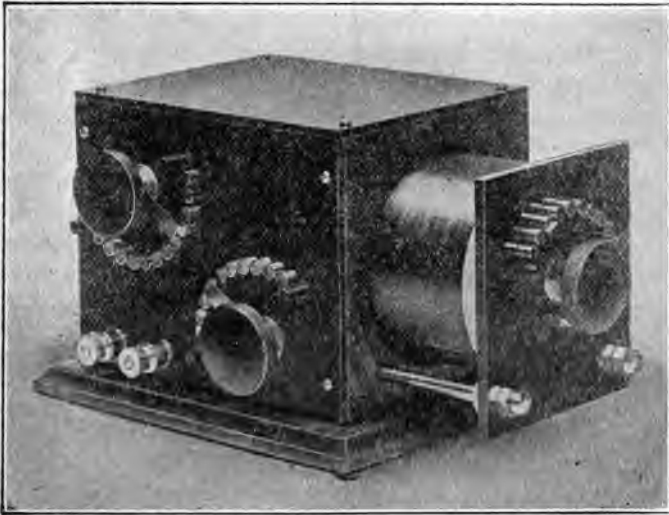

**Fig. 10.**—A Well-designed Loose Coupler from the Radio Equipment Company.

good because they give a poor contact, wear away the wire, short circuit the turns with grains of copper, and touch more than one turn at a time.

**C. Single switches.** Where no variable condenser is used to tune to the wave-length between the inductance switch taps, the taps should be brought out as frequently as possible. If a tuning condenser is employed, the taps should be arranged to give a wave-length overlap of 10 per

cent. to 20 per cent., by the condenser between the inductance steps.

**D. Double switches.** Units and tens switches are often used without tuning condenser. One set of taps is taken off with short steps, while the other set are in steps equal to the total number of turns controlled by the first switch.

**E. Geared switches.** A set of units and tens switches can be geared together so that, while the contact of the tens switch is moving from one point to another, the units switch will rotate through its range. Thus both switches can be controlled by a single handle.

**F. Dead-end switches.** Some dead-end switches are so arranged that the unused sections of the coil are disconnected from each other and the part in use. The purpose is to prevent the unused sections from absorbing energy.

A better and simpler way is to short-circuit the unused turns by connecting the switch-blade to the end of the coil. This method is not good for large inductances, however, as the inductance and capacity of the unused part may have a wave-length sufficiently great to be a lower harmonic of the waves in the active section. In such a case, the coil should be short-circuited at several points in the unused part.

**G. Method of bringing out taps.** Inductance coil taps should not be in the form of a loop, but a single wire soldered to the winding at the coil. This keeps down distributed capacity losses. Taps should be arranged in an orderly manner, not bunched together. Where taps are brought out from moving coils, they should be clamped by bakelite strips or secured in such a way that the bending strain will not be concentrated at the soldered joints.

## CHAPTER IV

### DESIGN OF RECEIVING CONDENSERS

A variable condenser for tuning should have a low, direct current resistance through the connected parts, negligible dielectric losses across the plates, and in the insulating material separating the two sets of plates.

#### 24. CAPACITY OF AN AIR CONDENSER

The capacity of an air condenser is given by the formula

$$C = \frac{A}{445604 t} \quad \dots \dots \dots (37)$$

$$\text{or } A = 445604 t C \quad \dots \dots \dots (38)$$

$$\text{or } t = \frac{A}{445605 C} \quad \dots \dots \dots (39)$$

The value of  $A$ , the area of the dielectric, refers to the total area between the plates. Thus, if a condenser is made of three fixed and two movable plates, each of 5 square inches, at maximum capacity there will be four dielectric areas, each of 5 square inches, making a total area  $A$  of 20 square inches.

#### 25. LOSSES IN RECEIVING CONDENSERS.

**A. Dielectric losses.** These losses include those in the medium separating the plates, as well as in the insulating supports. While there is practically no loss in an air dielectric, collections of dust on the plates are harmful. All corners should be rounded, so there will be no concentrated fields around points between the sets of plates.

Fibre, mica, bakelite, and similar materials interposed between the plates cause a serious power absorption.



The leakage path between the sets of plates should be long, and the dielectric of bakelite, hard rubber, or porcelain. Bakelite is not as good as the other materials, though it is satisfactory if in the form of a large plate. Moulded end plates are very poor, as shown by tests in which, at 200 meters, the losses ran as high as 50 per cent.

Small insulating bushings, set in metal end plates, cause a concentration of the electrostatic field, resulting in large losses.

**B. Resistance losses.** Condensers should be so constructed that there is a negligible resistance in the leads

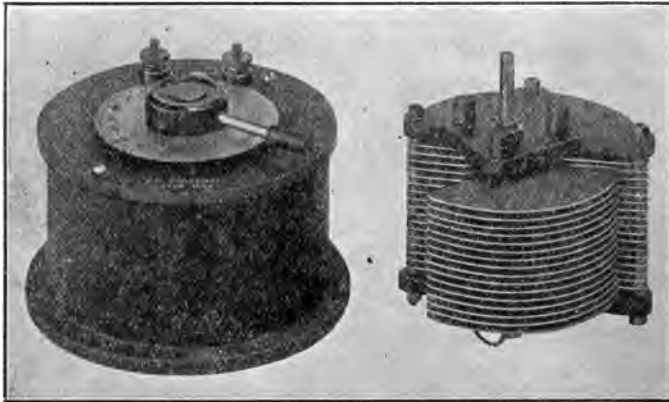

Fig. 11.—A Straight Line Type Condenser made by the General Radio Company.

and between the connected plates. The leads should have large contacting surfaces of constant pressure, or they should be soldered. The washers separating the plates should be large enough to give a good contact. Condensers having milled supports to which the plates are soldered are best.

**C. Effect of losses.** Condenser losses reduce the signal strength and give broad tuning. Used with an audion detector, they reduce the voltage on the grid.

## 26. TYPES OF VARIABLE CONDENSERS.

**A. Sliding plate type.** Condensers made with one set of plates sliding in and out on grooved insulating supports are obsolete. They are not satisfactory mechanically, and have losses due to the collection of dust on the support. Moreover, they require a large amount of space.

**B. Rotating straight line type.** This type of condenser has semi-circular rotating plates, giving a constant ratio of scale degrees to capacity. Almost all tuning condensers are of this sort.

**C. Square law type.** To give a straight line wavelength calibration, the square law condenser is made with offset variable plates so that the dielectric area is in proportion to the squares of the scale degrees, Fig. 13. In general, there is little advantage in using this type over the straight line type except where the straight wavelength calibration is necessary, as it takes up more space for its capacity than the straight line type.

**D. Geometric progression type.** Decimeters require a condenser giving a calibration curve in the form of a geometric progression.

## 27. DESIGN FEATURES.

**A. Bearings.** The bearings for the rotary plates of a variable condenser should be of brass, with a steel shaft.

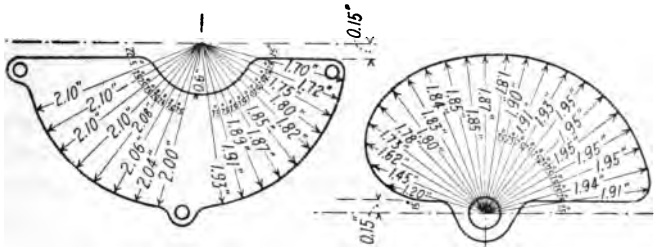

Fig. 12.—Shape of Square Law Type Condenser Plates.

They should be conical, or have large surfaces, and adjustable, so that any wear which may develop can be taken up. Light condensers work satisfactory if the shaft works in a

hole in the bakelite end pieces, though this design is not good for calibrated instruments. The use of a pointed screw for a lower bearing is to be avoided, for the point, carrying the weight of the rotary plates, soon wears off, changing the capacity.

**B. Rigidity.** Greatest rigidity is attained in condensers having brass plates soldered in milled brass supports. However, the usual washer spacing is satisfactory, if the supporting rods are properly proportioned to the weight of the condenser. The shaft and washers of the variable plates must be extra large to keep the plates in place.

**C. Connections.** There are several ways to make connections to the rotary plates. A switch arm can be fastened to the shaft moving on a semi-circular ring secured to the rear end plate. Spring washers are good if the contacting surface is large. Braided pig-tails or coiled copper ribbon, soldered to the shaft, are good if the condenser is not used in an accurately calibrated circuit.

**D. Balanced Condensers.** Large condensers are made with one-half of the plates on one side, and half on the other, to balance the weight of the rotary plates. Other types have a balancing weight on the shaft.

**E. Double condensers.** To obtain double the capacity of the ordinary condensers in the same space, condensers are made with two sets of fixed and rotary plates. The sets of rotary plates, mounted on a single shaft, are insulated from each other. One set of fixed plates is connected to one set of rotary plates, and the other set of fixed plates to the other rotary set. Leads are taken from the two fixed sets. Capacity is minimum when the connected plates are interleaved, and maximum when opposite plates are interleaved.

A more complete description is given in *Everyday Engineering*, November, 1919.

**F. Double wave-length range type.** When a variable condenser is used with an adjustable inductance, only  $180^\circ$  of the rotary movement is usable, and, when turned

from minimum to maximum, it must be turned back to minimum for the next inductance step.

The double wave-length range type has two sets of fixed plates and one rotary set. A switch is arranged on the shaft which connects one fixed set to the first induc-

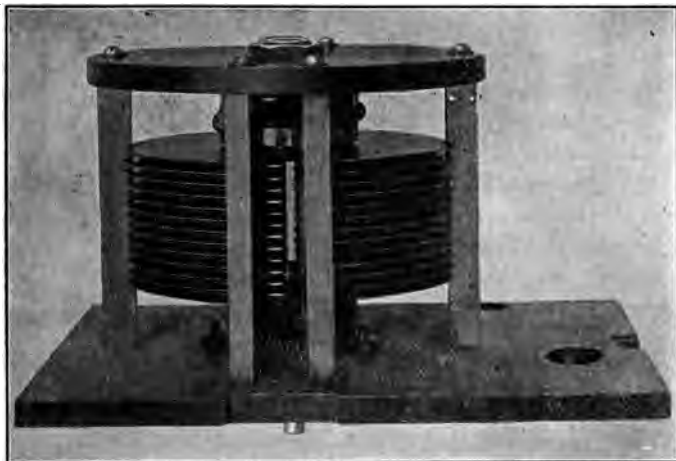

**Fig. 13.**—Condensers of this Type are Used in Wave Meters for the Signal Corps.

tance step. When the capacity is maximum with that set, the switch connects the other fixed set to the next tap, making the capacity minimum again.

**G. Milled condensers.** A very expensive, though extremely rugged way of building a condenser is to mill the sets of plates from a solid metal block. Attempts have been made to die-cast condensers, but this is expensive because a final milling operation is necessary because the plates warp slightly when taken from the casting machine.

**H. Vernier condenser.** Five variations of capacity are determined by means of a separate knob with a reducing gear to the condenser shaft, or by a small two-plate condenser shunted across the large condenser. Another method, used by the de Forest Company, is to have a

single plate, mounted on the shaft, which can be adjusted by a separate handle with respect to the top plate of the fixed set.

**I. Metal cases and shields.** To prevent slight variation of capacity due to the capacity to ground of the body, condensers should be put in metal cases, connected to the ground, or shielded by a grounded metal plate. Often times the receiving set panel is covered, at the rear, with a grounded copper, brass, or aluminum sheet. When this is done, care must be taken to prevent eddy current losses in the plate by making a number of slits across it, and keeping the coils and wiring several inches back.

**J. Scales.** While 360° ordinarily constitute a circle, it is usual to use 200°, or 100° for a semi-circle, on radio condenser scales.

## 28. MICA AND PAPER CONDENSERS.

**A. Capacity.** The capacity of a condenser having a mica dielectric is

$$C = \frac{A}{6855.45 t}$$

and of a paraffined paper condenser.

$$C = \frac{A}{12731.5 t}$$

Owing to the variations in the dielectric constants of different specimens, the results obtained will be only approximate, varying as much as 15 to 20 per cent.

**B. Use of Mica and Paper Condensers.** In the tuning circuits of receivers nothing but air condensers should be used, as the losses in mica and paper condensers are large at high frequencies. As grid, bridging, or audio frequency tuning condensers however, they are satisfactory.

The humidity of the atmosphere will vary the capacity and losses in these condensers. Therefore, they should be thoroughly impregnated and sealed.

## CHAPTER V

### AUDION DETECTOR CIRCUITS

The enormous amount of data which has been worked out on audion detectors makes it necessary to keep, in this book, to the practical considerations. Readers interested in the theoretical side of this subject are referred to the series of articles by L. M. Clement, starting in the April, 1919, issue of *Everyday Engineering Magazine*.

#### 29. THE THREE CIRCUITS OF THE AUDION.

Three separate circuits are employed with an audion—the filament, grid, and plate circuits.

**A. Filament Circuit.** The filament circuit comprises a source of current, a current regulator, and the audion filament, from which negatively charged electrons are radiated.

**B. Plate Circuit.** Across the filament and plate of the audion a high voltage battery and indicating device or amplifying circuit are connected. The battery breaks down the space between filament and plate, drawing the emission from the filament to the plate.

**C. Grid Circuit.** The controlling voltage from the tuning circuit is applied to the grid. Varying the charge on the grid changes the filament-plate current.

#### 30. AUDION CHARACTERISTICS.

**Control of Plate Current.** The plate current is varied in three ways:

- (a) By changing the voltage of the plate or *B* battery.
- (b) By changing the filament current.
- (c) By putting a charge on the grid.

Modern vacuum tubes require no fine variation of the plate voltage. The battery to be used is generally specified for the particular tube, and is kept constant. Increasing the plate voltage decreases the resistance between filament and plate, and increases the plate current up to the point of saturation.

Filament current is also kept constant. The best tubes, such as the Western Electric types, have a filament which

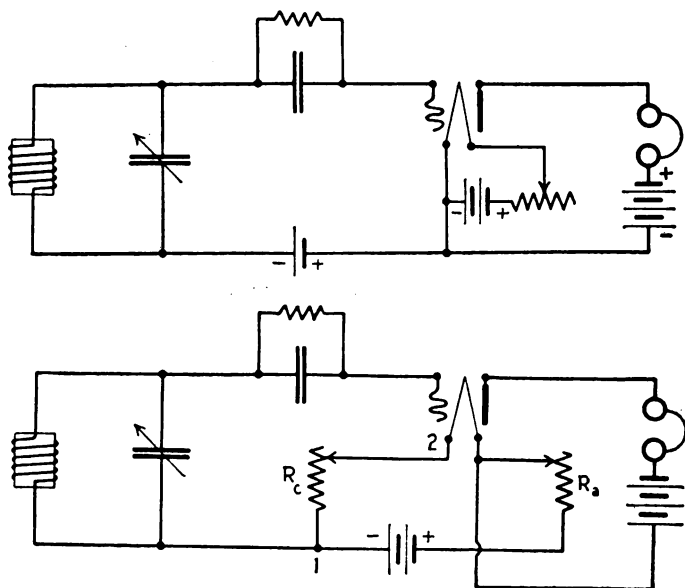

Fig. 14.—Two Methods by which a Negative Charge can be put on the Grid.

burns at a dull red. Others, with tungsten filaments, require a current sufficient to make them glow brilliantly. Increasing the filament current increases the electronic emission up to the point of saturation for the given plate voltage.

Changes in the plate current from the incoming signals are produced by the charges put upon the grid of the

tube. A positive charge increases the plate current, and a negative charge decreases it. It is advisable, however, to keep a small negative charge on the grid, so that incoming positive charges will not be great enough to make the grid positive. The reason for this is that, when the grid is positive, a small amount of current flows from the filament to the plate. This is the same as putting a resistance across the tuning coil, thus reducing the signal strength and broadening the tuning.

Fig. 14 shows two methods for putting a permanent negative charge on the grid. The first circuit has a battery of 1.5 or 3.0 volts, the negative or zinc side connected to the grid. A finer adjustment, without an extra battery, is obtained by the second circuit.

It will be seen that, due to the resistance,  $R_c$ , there is a difference in potential between point 1 and 2. If the negative side of the battery goes to point 1, the grid will be negative with respect to the filament. The amount of negative grid potential is

$$E_c = I R_c$$

Different tubes require different grid charges for maximum signal strength. Also, a slight change for telegraph and telephone signals is needed. While the negative grid charge and corresponding resistance can be determined from a grid voltage, plate current curve of the tube, the easiest way is to determine the value of resistance experimentally, using the correct filament current. Then a fixed  $R_c$  can be inserted. A variable filament resistance,  $R_a$ , will make it possible to keep the filament current at the right value in case the voltage of the filament battery drops down.

The circuit in Fig. 14 shows a high resistance leak of 0.5 megohm around the grid condenser. Without this resistance the grid charge control will not function.

Signals are considerably improved when the grid is adjusted to the right potential.



**31. THE GRID CIRCUIT.**

**A. Tuning apparatus.** As previously explained, the plate current is controlled by voltage changes on the grid.

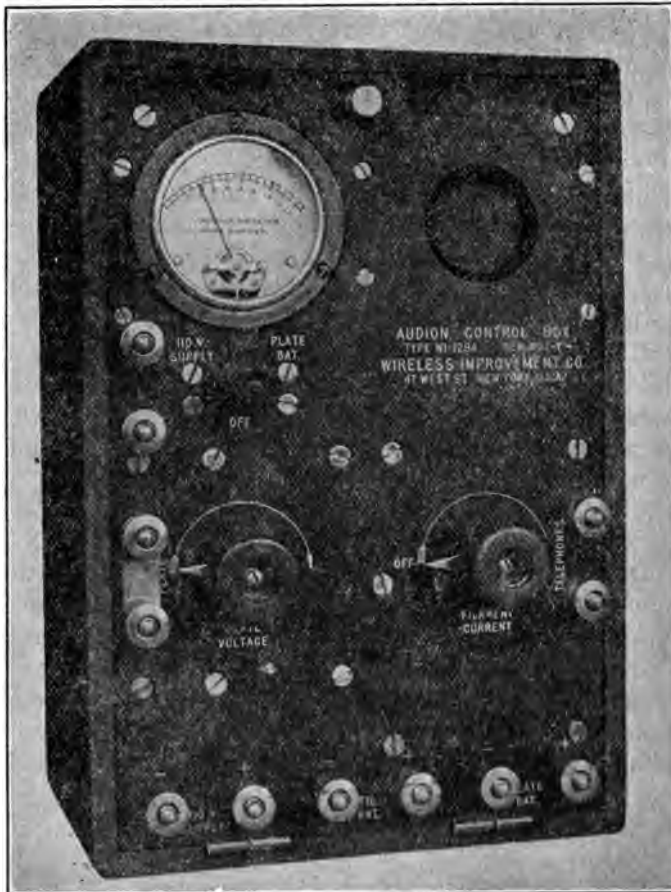
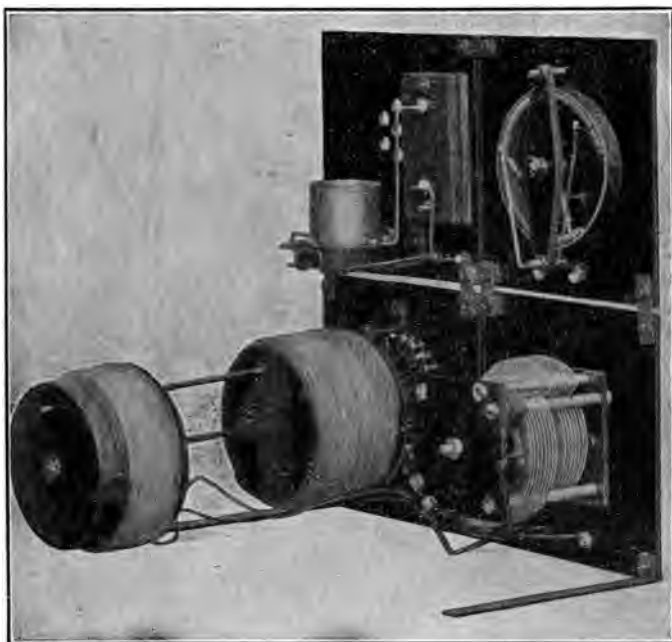

**Fig. 15.**—A Wireless Improvement Audio Control Box Operating on Batteries or 110 Volts Direct Current.

To obtain the maximum voltage from the incoming signals, the secondary tuning inductance must have a minimum capacity and high frequency resistance. Most

careful consideration should be given to the design of the coil. The tuning condenser is also an important factor. The capacity should be as small as is practical for tuning purposes.

**B. Grid condenser.** It is usually said that the grid condenser keeps the negative charge off the grid. The

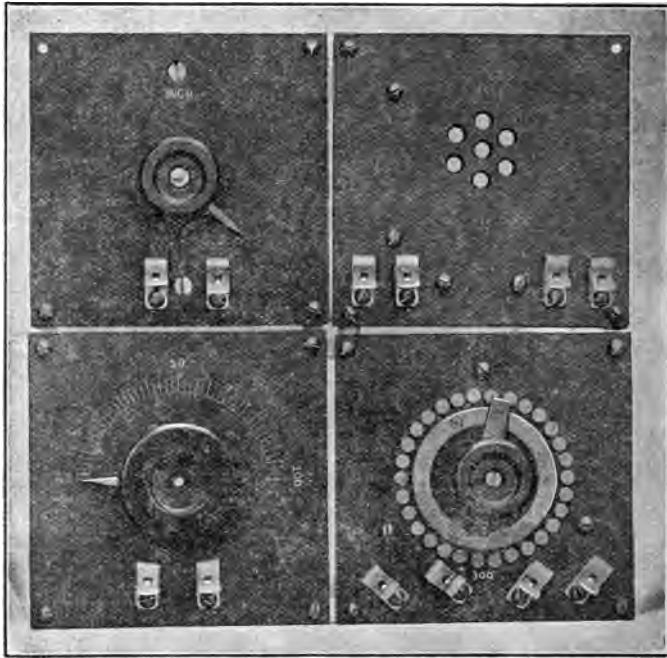

**Fig. 16.—A Standardized Panel Type Audion Receiver for Short Waves.**

grid is isolated from the tuning circuit by the condenser. The positive half cycles of the incoming voltage causes a current to pass from the filament, which is positive with respect to the grid, to the grid. During the negative half cycles, no current flows. Thus a negative charge is accumulated on the grid, and this charge, as explained in Section 30, reduces the plate current. A train of oscillations

serves to put one charge on the grid, with a corresponding single charge in the plate current through the telephones. Thus the vibrations of the telephone receiver diaphragm correspond to the spark frequency of the transmitter, and not the radio frequency.

**C. Grid leak.** If the insulation of the grid condenser were perfect, the negative charges would pile up and ren-



**Fig. 16a.**—The Controls for the Set Shown in Fig. 16.

der the tube inoperative. However, these charges leak off between the wave trains. To prevent blocking, that is, the accumulation of negative charges, a resistance of 500,000 to 1,000,000 ohms is usually connected around the grid condenser.

The grid leak is usually made of a small strip of paper

dipped in water-proof ink, or of a lead-pencil mark across a piece of paper. Popping noises and rumblings in the telephones are often due to microphonic action in the grid leak.

### 32. THE PLATE CIRCUIT.

**A. Plate impedance.** There is a certain value of resistance between the filament and plate, varied by the



**Fig. 17.**—A Telephone transformer is used to match the Impedance of the Audion.

adjustments of the circuit. In the average receiving tube, this is taken as 50,000 to 100,000 ohms. To obtain the maximum effect in the phones, the telephones should have a high resistance at average speech frequencies, 800 cycles. For greatest efficiency, telephone transformers are used so that the impedance of the circuit across the filament and plate will equal the plate impedance.

**B. Tuning in the plate circuit.** Some circuits call for radio frequency tuning in the plate circuit. This is generally unsatisfactory as it introduces a difficult adjust-

ment, and, in the matter of amplification of signals, offers no advantage. Audio frequency tuning has been found entirely unsatisfactory. The subject of feed-back coupling is treated in a separate Section.

**C. Control of plate voltage.** While standard 22.5-volt batteries are almost universally used to supply the voltage across the plate and filament, it is sometimes necessary to adjust the voltage. This can be done by a simple switch or by means of a potentiometer. Since a potentiometer is really a high resistance shunt across the battery, a small amount of current is wasted through the resistance. Therefore, the potentiometer should be of 10,000 to 25,000 ohms, and a switch should be inserted so that the battery can be disconnected when not in use.

Carbon sectors are most generally used. They are made up with a porcelain body coated with graphite. A carbon contact must be used because a metal contact deposits tiny grains on the graphite sector which reduce its resistance.

**D. Noises.** Howling and squealing sounds in the telephones are largely due to poor plate voltage adjustment or capacity or inductive coupling back to the grid circuit. Plate circuit wiring should be well separated from all grid circuit connections.

**E. Bridging condenser.** A condenser of 0.001 mfd. is often connected around the phones and *B* battery to act as a by-pass for radio frequencies which may be present in the plate circuit. A mica or air condenser, preferably variable, should be used.

## CHAPTER VI

### OSCILLATING AUDION CIRCUITS AND UN-DAMPED WAVE RECEIVERS

Although there is a multiplicity of methods for making an audion circuit oscillate, only the best and most widely used are described here.

#### 33. INDUCTIVELY COUPLED OSCILLATORS.

**A. Tickler coil coupling.** The tickler coil, Fig. 18, is most often used to amplify spark signals and to make the

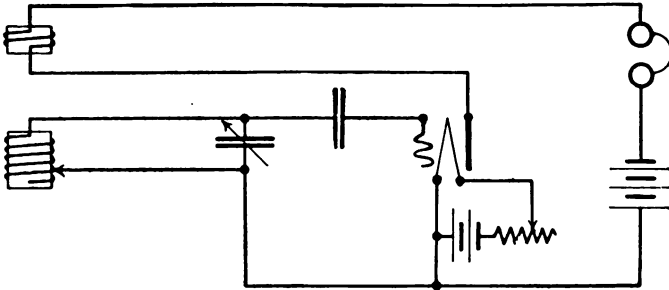

Fig. 18.—The Typical Tickler Coil Circuit for Regeneration or Undamped Wave Reception.

audion oscillate. It is simply a small inductance in the plate circuit coupled to the secondary of the loose coupler or to a separate coil in series with the secondary inductance.

There seems to be no optimum inductance value for the tickler coil. It is often made equal to the secondary for short waves, and as small as 0.1 the secondary inductance for long waves.

Coupling to the secondary must be adjustable to obtain the proper feedback action from the plate circuit to the grid side.

**B. Tapped secondary coupling.** With a circuit as in Fig. 19 no adjustment is needed, though the strength of the oscillations can be varied by changing the taps which

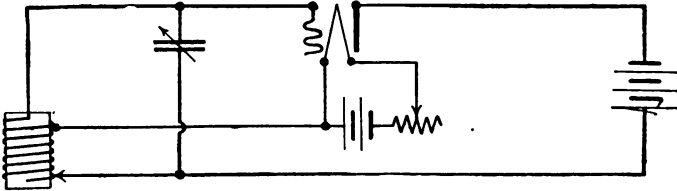

Fig. 19.—The Secondary Circuit of an Undamped Wave Receiver.

goes to the filament. Ordinarily, the tap is taken off at a point just below the center, toward the end connected to the plate.

The wave-length is not varied by changing the coupling tap. It is determined by the total inductance of the secondary and the secondary tuning condenser.

#### 34. CAPACITY COUPLED OSCILLATORS.

**A. Separated tuning condenser method.** In this circuit Fig. 20, two separate tuning condensers are used, in

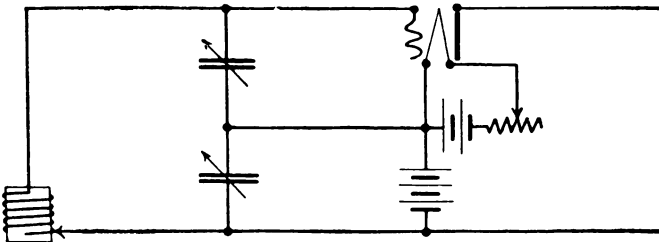

Fig. 20.—Capacity Coupling is Used in this Oscillating Circuit.

the connection from the center running to the filament. The strength of the oscillations can be varied by making one condenser larger or smaller with respect to the other.

The wave-length depends upon the inductance of the secondary coil and the capacity of the two condensers. It should be remembered that these condensers are in

series. This introduces difficulties because of which this type of circuit is seldom used for receiving.

**B. Tickler condenser method.** The coupling condenser shown in Fig. 21 is made of two fixed and one variable plate, arranged so that when capacity is increased between

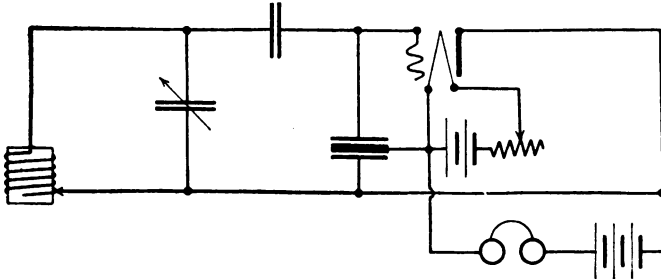

**Fig. 21.—Another Method for Making the Circuit Oscillate.**

one fixed plate and the variable plate, the capacity to the other fixed plate will be reduced. The fixed and variable plates may be semicircular 3 and 2½ inches in diameter respectively.

**C. Grid and plate bridging condenser method.** Feed-back coupling can be accomplished by connecting a vari-

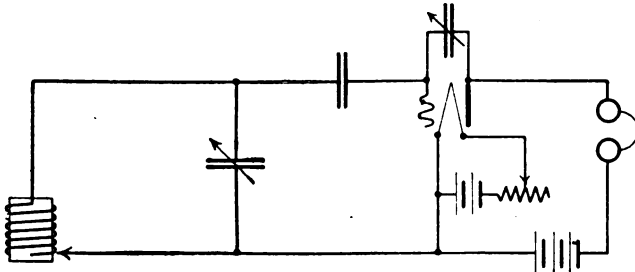

**Fig. 22.—A Bridging Condenser Provides Coupling between the Plate and the Grid Circuits.**

able condenser of 0.0005 mfd. maximum across the grid and plate. However, the adjustable is not stable on the strength of the oscillations easily controlled. Fig. 22 gives the circuit.



**D. Other methods.** Almost any way in which, by capacity an inductive coupling, the plate circuit is connected with the grid will make a tube oscillate in varying degrees.

### 35. LOCALLY OSCILLATING CIRCUITS FOR UNDAMPED WAVE RECEPTION.

**A. Heterodyne reception.** This reception of undamped waves is accomplished by imposing a slightly different frequency on the incoming oscillations. If, for example, oscillations of 100,000 cycles are being received, and local oscillations of 101,000 cycles are impressed, a beat note of 1,000 cycles will be produced in the telephones.

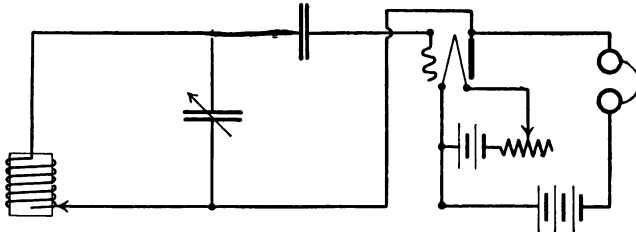

Fig. 23.—The Ultraudion Circuit for Undamped Wave Reception.

method, while good for short waves, causes a loss, by detuning, at long wave-lengths.

In practice, the primary circuit is closely tuned to the transmitter. The secondary is detuned, to give an audible frequency. So it is that the secondary circuit is not adjusted to the frequency of the received signals.

At short waves, a slight detuning in wave-length makes a large difference in frequency, so that this effect is not pronounced. Long waves, however, have a low frequency. Thus a small difference in frequency requires a considerable change in wave-length.

Consider Fig. 25. This shows the signal strength when a receiver is tuned above and below the wave-length of the transmitter. A maximum amount of energy flows in the secondary when it is adjusted to 18,000 meters,

but, at 17,000 the wave-length for a 1,000-cycle beat note, only 55 per cent. of the available energy is being used. This is obviously a considerable loss, of special importance when the signals are weak.

That this percentage of loss decreases with the wave-length is shown by Fig. 25. Here the curve shows the energy in the secondary when it is tuned above and below

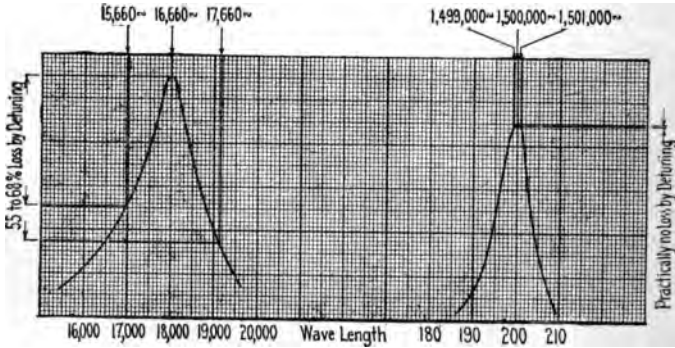

**Fig. 24.**—This Wireless Special Set Contains an Oscillating Circuit Which Can Be Connected to the Secondary.

the wave-length of a 200-meter transmitter. The detuning to produce 1,000-cycle beats is less than 1 meter, and practically no energy is lost.

On wave-lengths about 5,000 meters, heterodyne reception should be accomplished by means other than the use of a detuned, oscillating circuit. The simplest method is to set up a separate oscillator, coupled to a straight receiving set.

**B. Ticker Coils.** There seems to be no definite relation between the inductance of a ticker coil, used as a



**Fig. 25.**—Showing the Loss at Long Waves from the Use of a Locally Oscillating Receiver.

feedback from the plate to the grid circuit, and the wave-length of the signals received.

For short waves the tickler is usually made with an inductance nearly equal to that of the secondary, while

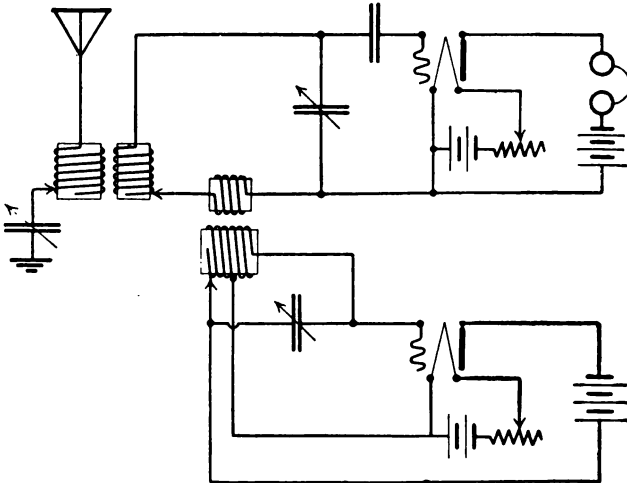

**Fig. 26.**—The Separated Oscillator Provides the most Efficient Means for Receiving Undamped Waves.

on long waves the tickler may be as low as 0.15 of the secondary inductance.

### 36. SEPARATE OSCILLATORS

The tapped coil oscillator is the easiest to handle and was for heterodyne reception. A coil coupled to the receiving set can be put in series with the main inductance of the oscillator, or the oscillator coil itself can be coupled to the primary of the receiving oscillation transformer.

Provision for varying the coupling is necessary so that the strength of the oscillations induced in the receiving circuit will be equal to those received at the antenna.

## PART III

### CHAPTER VII

#### DAMPED WAVE TRANSMITTERS

The mathematical design of transmitting circuits involves separate problems to which many books are already devoted. It is obviously impossible to dispose of the subject in one, or even many chapters. Experimenters usually do the easiest thing, which in this case is the most satisfactory and practical—that is, they buy their sending equipment.

Because this is a book for the practical experimenter, formulas and data on building spark coils and transformers will not be given. Either instrument can be purchased as cheaply as it can be made, and the manufactured article will, if it comes from a reputable concern, represent an amount of experimental work beyond almost any experimenter.

Another feature which, from the title of this book, might be expected here, but will not be found, is data on resonance circuits. Such considerations were introduced by power engineers long ago, but the field of experimenters is just beginning to be aware that resonance circuits have been used.

However, it is impractical to introduce this subject in this book because two of the essential factors cannot be determined, one, the characteristics of the power generator and, two, the characteristics of the transformer.

There is also the wave-length limitation which prohibits experiments which might result in an increased efficiency of the sending set.

Thus it will be seen that the possibilities for designing a spark coil or transformer set are reduced almost to the consideration of possible expenditure, the source of power available, and the wave-length of the oscillating circuits. This is not intended to infer, however, that there is no choice between the various instruments on the market or the types which can be built by the experimenter, but that the limitations preclude large variations from the standard designs, and that extensive experiments on transmitting apparatus call for the equipment of a commercial laboratory.

### 37. SPARK COIL SETS.

The spark coil, though often condemned as being responsible for much interference, is really good for short-distance transmitting when properly handled.

**A. Types of coils.** A spark coil cannot be judged by the length of the spark which it gives. The spark should be a short, heavy flame, hot enough to ignite a piece of paper. Power consumption is a more accurate way to classify spark coils, as is done in the transformer.

The vibrator should produce a fairly high note with very little sparking at the contacts. Current consumption is increased with the vibrator speed.

**B. Current supply.** Dry batteries can be used to run a spark coil, but a storage battery gives better results and, over a period of months, is more economical. Electrolytic rectifiers for 110 volts a. c. or electrolytic interrupters for d. c. are satisfactory, if purchased from a reliable company, although some which have been put out are only good for blowing fuses. A step down transformer does not give a good transmitting note unless the vibrator can be synchronized with the a. c.

**C. Telegraph key.** Any type of light telegraph key can be used to operate small spark coils. The contacts should be cleaned frequently to prevent a high resistance connection which would reduce the current to the coil.

**D. Plain spark gap.** A plain spark gap is most often

used. The contacts should be of zinc, about  $\frac{1}{4}$  inch in diameter, and flat at the adjacent faces.

One contact should have a threaded adjustment and a knob of insulating material so that the gap can be altered while the set is in operation. A bakelite or marble base is required to prevent leakage across the gap.

**E. Rotary spark gap.** Because the speed of the vibrator is not steady, it is impossible to synchronize the vibrator and spark gap. However, the rotary gap can be used if the gap is very short and the rotor run at a high speed.

**F. Quenched spark gap.** Very satisfactory results have been obtained by turning down silver half-dollars for quenched spark-gap faces. Fig. 27 shows form. Mica

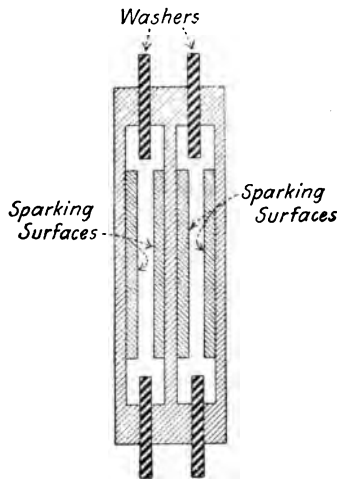

**Fig. 27.**—A Sectional View of a Simple Quenched Spark Gap.

rings can be used as separators. Two single and one double-gap sections are enough for a spark coil. They should be mounted between two flat surfaces in such a way that they can be pressed tightly together without warping the silver gaps.

**G. Transmitting condenser.** Considerable loss occurs in an imperfect transmitting condenser. The usual home-

made glass plate type is particularly liable to fall down in this respect. However a spark coil sets, good results can be obtained if the condenser is carefully built.

Ordinary window glass is not good. Photographic plates are the best that can be obtained readily. They should be covered on both sides with heavy tinfoil, pressed free from wrinkles. A switch is required so that eight to sixteen glass plates, 5 x 7 inches, can be connected.

Moulded or mica condenser of 0.004 or 0.005 mfd. are preferable.

**H. Oscillation transformer.** An oscillation transformer must be used even with a spark coil set, to allow an adjustment of the coupling and decrement. The primary should have three turns of copper ribbon or edgewise wound strip 5 to 8 inches in diameter. For the secondary, eight turns are required, of a diameter 2 inches greater than that of the secondary. A space of  $\frac{3}{8}$  or  $\frac{1}{2}$  inch between the turns is sufficient.

The secondary should be arranged to pull out or turn away from the primary so that the coupling can be varied. Clips are needed so that all of the turns are available for tuning.

**I. Hot wire ammeter.** To measure current in the secondary circuit, a hot wire ammeter is needed. A range up to 2 amperes is sufficient for the average spark coil set.

**J. Wiring.** The importance of the wiring must not be overlooked. The length of the leads can be reduced by grouping the instruments. No. 14 bare or insulated copper wire is large enough. Small wires or loose connections increase the resistance of the circuit and make the decrement higher. This must be compensated for by loosening the coupling which decreases the power radiated.

### 38. TRANSFORMER SETS.

**A. Closed core transformers.** The closed core transformer is operated on 60-cycle a. c. or higher frequencies. It has the disadvantage of requiring an external controlling



impedance for, when a discharge occurs across the secondary, the secondary winding is practically short-circuited, with the result that an excessive current is drawn by the primary. This must be controlled by an impedance in series with the primary circuit. Such an impedance is made up of a laminated or iron wire core 8 inches long and  $1\frac{1}{2}$  inches square or in diameter, as the case may be, wound with 300 turns of No. 18 annunciator wire tapped every 50 turns. This impedance will serve for a  $\frac{1}{4}$  or  $\frac{1}{2}$  kilowatt transformer. For a 1 kilowatt transformer, No. 16 wire is needed.

**B. Magnetic leakage transformers.** A magnetic leakage transformer is so constructed that, if the leakage gap

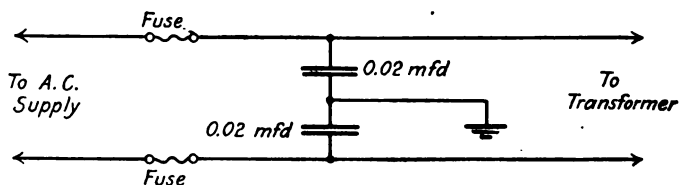

Fig. 28.—The Circuit of a Protecting Device for 110-Volt Supply Lines.

were closed, the primary and secondary would be, in effect, wound on two separate closed cores. The Clapp-Eastham type *T* transformers are built in that way.

The advantage of this type is that it is self-controlling. When a discharge takes place across the secondary, lines of magnetic force stream the leakage gap, virtually closing the part of the core on which the secondary is wound. The impedance of the secondary is increased thereby, and an excessive current is unable to flow.

**C. Protective devices.** The underwriters' rules call for a protective device to prevent surges from the transformer back into the live. Fig. 28 gives the connections for a single and satisfactory type.

Two condenser of 0.02 mfd. are connected across the line, with a ground connection between them. Fuses are

also needed, of a size to carry a 50 per cent. transformer overload.

**D. Telegraph keys.** Because a current drawn by a transformer is large, the key contacts must have surfaces

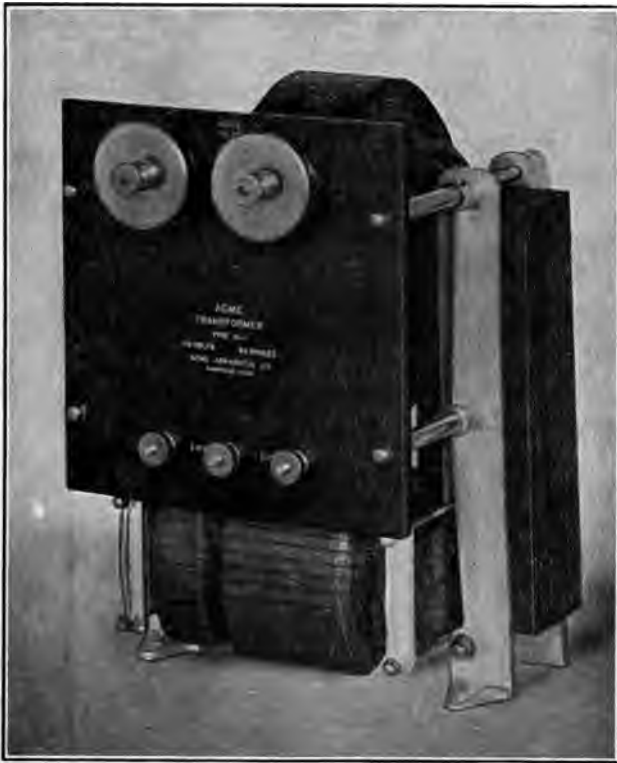

**Fig. 29.**—The Acme Transformer Contains a Controlling Impedance.

$\frac{1}{4}$  to  $\frac{1}{2}$  inch in diameter. Sparking the contacts can be reduced by shunting them with a paper condenser of 0.01 mfd.

**E. Current supply.** Transformers are generally designed to work on 110 volts a. c. In ordering a transformer, it is necessary to state the frequency of the current supply. When 500 or 1,000 cycles is available, it

offers the advantage of a higher spark note, and makes possible the use of a smaller condenser and transformer.

**F. Plain spark gaps.** The high voltages and the heavy current handled by the spark gap of a transformer set requires comparatively heavy construction and the best of insulation. Gap faces should range from  $\frac{1}{2}$  inch in diameter for  $\frac{1}{4}$  kilowatt to  $\frac{3}{4}$  inch for 1 kilowatt. Zinc, nickel, steel, silver, or brass are used for the electrodes. Radiators behind the electrodes are needed if the transmitter is used for very long at a time. It is important to have the gap faces absolutely parallel, otherwise the sparking will occur at one point instead of over the entire surface.

The International Radio Company uses an excellent type of gap, made of plates  $1\frac{1}{2}$  inches in diameter and

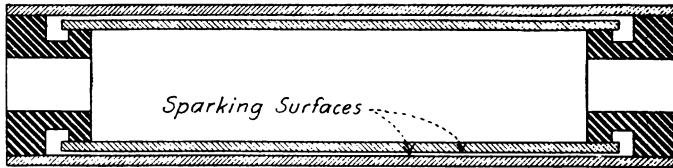

**Fig. 30.**—A Sectional View of the Lowenstien Type Quenched Spark Gap.

$\frac{1}{8}$  inch thick, separated by mica washers. Four to eight of these plates are used, depending upon the power. The sparking takes place around the edges of the plates. A bakelite rod, passing through the center, holds the gaps and washers in place.

For the base, bakelite is preferable. If cost or difficulties of obtaining it prohibit the use of a heavy bakelite base, a  $\frac{1}{4}$  inch plate can be mounted on a hollowed wooden base.

**G. Quenched spark gaps.** A disadvantage of the quenched gap on a 60-cycle set is the low note which it produces. For this reason this type is seldom used for experimenters' transmitters. An interesting gap originated by the Lowenstien Company is shown in Fig. 30.

It consists of two concentric brass or copper cylinders, sealed and separated by bakelite washers. This is simple to make and just as good as the usual type. If the gap heats excessively, a fan, operated by a battery motor, can be arranged to send an air current through the gap.



**Fig. 31.**—An Excellent Example of the Oscillation Transformer, from the International Radio Company.

**H. Rotary spark gaps.** Most of the rotary spark gaps for experimental sets now on the market are of inefficient design. The purpose of the rotary gap is to provide a short, low resistance gap during the time of the first dis-

charge of the condenser, and to damp out the oscillations which follow the first impulse, by increasing the length and resistance of the gap.

To accomplish such a result the electrodes should not be large, for they will not increase the gap length quickly enough. Broad, blunt-edged electrodes, parallel to the axis of the motor shaft, are preferable. In this case the stationery electrode is in the plane of the rotor. This also requires a blunt-edged electrode.

The rotor can be cut from a solid piece of brass  $\frac{1}{8}$  inch thick, insulated from the motor shaft by a bakelite plate. It is essential that the rotor runs true, otherwise the gaps will not be of the same length, and vibration will be created. The stationery electrode must be closely adjustable.

Rotary spark gaps with several gaps are not good.

**I. Transmitting condenser.** Particularly on large sets, the condenser is a source of serious losses, the greatest of which are those in the dielectric. Other losses are due to resistance and discharges around the plates.

Glass-plate condensers, if made from specially selected glass, are satisfactory, though they are liable to break down if overloaded to any great extent. This is also true of the Leyden jar types.

Murdock moulded condensers are, perhaps, the most practical for experimental use. They are efficient, withstand fair overloads, and are not expensive.

Mica condensers are best of all, in the matter of efficiency, but their cost puts them beyond most experimenters.

**J. Oscillation transformer.** Heavy insulating pillars of bakelite are needed to support the turns of the oscillation transformer. As little metal as possible aside from the conductors should be used in this instrument for the high frequency currents induce eddy losses in the metal parts.

Edgewise wound ribbon or solid copper wire present considerable resistance, for the current tends to crowd on



**Fig. 32.**—Receivers of this Type were Built by the Wireless Specialty Company, for the U. S. Navy Destroyers.

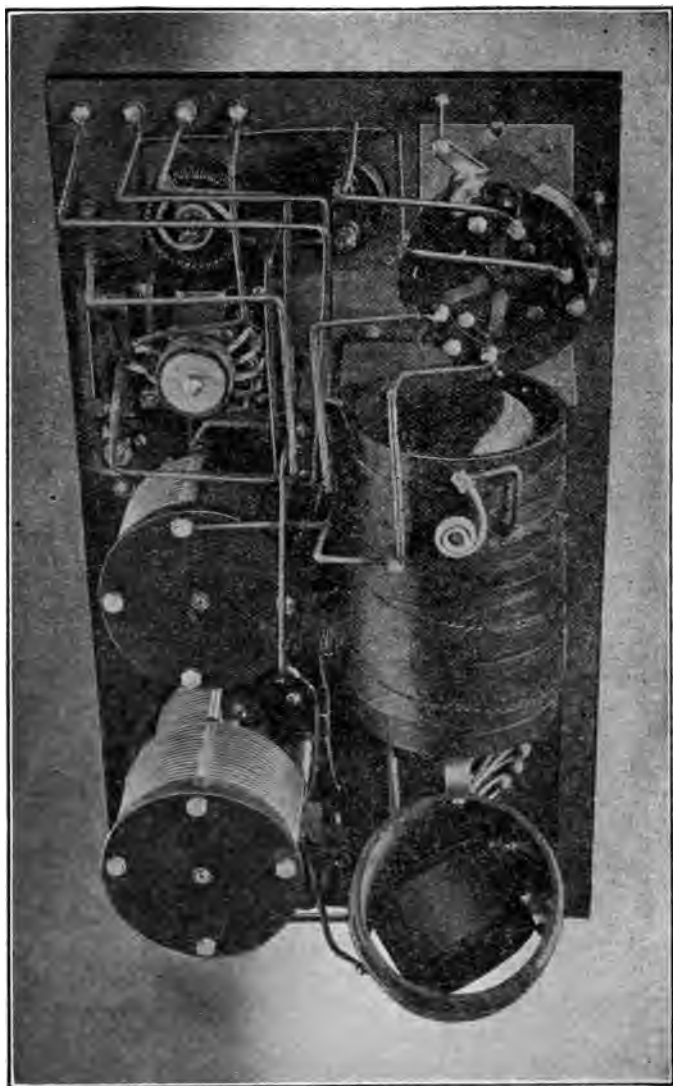

**Fig. 33.**—Rear View of the Set Shown in Fig. 32.

the inner diameter of the conductor. Therefore flat copper strip,  $\frac{1}{4}$  to  $\frac{1}{2}$  inch wide, should be used wound in the form of a solenoid or flat pancake. The thickness is not important, though it should be No. 24 B. & S. gauge or more.

### **39. TRANSFER AND LIGHTING SWITCHES.**

Experimenters often construct their instruments and antennas with great care, insulating each part carefully, but neglect the transfer and lightning switches. Insulation at these points is as important as at any others. A slate base and the dust, largely carbon particles, which collect on an exposed lightning switch, form a good conducting path between the antenna and the ground.

Both transfer and lightning switches should be set upon corrugated insulating pillars, with the leakage path between antenna and ground several inches in length.



## CHAPTER VIII

### VACUUM TUBE TRANSMITTERS

For telegraphy, either damped or undamped, and telephony, the vacuum tube has taken a permanent place in the radio field, in competition with the older spark coil and transformer. 200 meter undamped telegraphy has the disadvantages of being difficult to heterodyne at the receiving station. This can be overcome, however, by the use of the rotary tone condenser.

Modulated vacuum tube transmitters in which a buzzer or tone circuit is employed to alter the undamped oscillations into audio-frequency groups are already popular. The low power telephone has also established itself among experimenters. Vacuum tubes of high power, that is  $\frac{1}{4}$  to 1 kilowatt, have not come into use because of the difficulty in obtaining the tubes. At present, therefore, experimental sets are confined to the use of De Forest Marconi *VT*'s, a type which leaves much to be desired when employed as transmitting bulbs.

The design of a 200 meter set is quite a different problem from that of the commercial type. Moreover, some of the apparatus calls for the cut and try method which has been so largely eliminated in receiving circuits. Consequently, this chapter must be more on how to make rather than how to design vacuum tube sets.

#### 40. ESSENTIALS OF VACUUM TUBE TRANSMITTING CIRCUITS.

**A. The four circuits.** A modulated vacuum tube transmitter can be divided into four circuits, the radiating, oscillating reaction and modulation circuits. If un-

damped waves are employed the modulation circuit is, of course, omitted. The radiating circuit includes an inductance, possibly a tuning condenser, and the antenna and ground. The oscillating circuit contains an inductance and capacity to which energy is supplied from the plate circuit. Means of coupling to the oscillating circuit either electro-magnetic or electrostatic, connected with the grid or filament, comprise the reaction circuit. In the modulation circuit is a telephone transmitter, tone circuit, or buzzer by means of which a varying change can be placed on the grid of the reaction circuit.

As a matter of fact these four circuits are often arranged in such a way that the same instruments are in the two or three of the dividing circuits. Of the many combinations, a few of the most successful are described in the following sections:

#### **41. A SIMPLE TRANSMITTER.**

The advantage of this type of undamped wave set is that one or more tubes can be used without complicating the circuit, and that an unusually small number of instruments is required. It can be used as a modulated telegraph or telephone set, as will be shown in Sections 42 and 43.

**A. Antenna tuning inductance.** The entire coil or part of it can be used in the radiating circuit, depending upon the amount of inductance needed to give, with the antenna capacity, the wave-length required. High frequency cable should be used on the coil, to keep the resistance of the radiating circuit as low as possible. Taps are provided to give a rough adjustment of the inductance.

**B. Antenna variometer.** A small coil is mounted inside the open end of the inductance just described, to allow a close adjustment of the total inductance in the radiating circuit. The dimensions of the winding can be determined by the data given in the previous chapters.

**C. Coupling adjustment.** By following the wiring,

diagram Fig. 34, it can be seen that a part of the tuning inductance is included in the plate or oscillating circuit. By varying the plate switch, the coupling to the antenna can be regulated.

**D. Reaction coupling.** The inductance of the reaction coil, connected across the grid and filament, cannot be

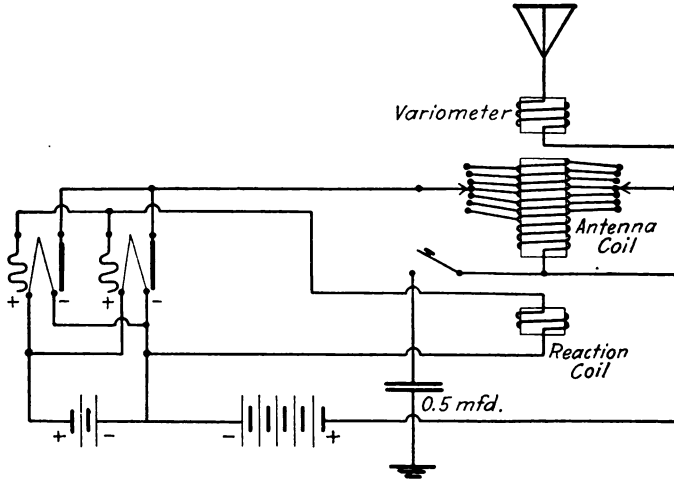

**Fig. 34.**—Undamped Wave Transmission can be Accomplished with this Circuit.

figured accurately. Practice, however, shows that it should have an inductance value nearly equal to that of the antenna coil. This winding can be of solid wire, as its resistance is not important. It should be located at the closed end of the antenna coil.

**E. Transmitting key.** Telegraphic signals are made by opening and closing the plate circuit. A condenser of 0.5 mfd. can be seen in the ground circuit. This does not affect the wave-length, but prevents the short-circuiting of the d. c. voltage supply to the plate.

**F. Additional tubes.** More vacuum tubes can be added to increase the power by connecting the plate and grids in parallel, and the filaments in series or parallel

**G. Method of adjusting.** The radiated wave-length depends upon the antenna capacity inductance of the tuning coil, of the variometer, and the mutual inductance between these two coils. Radiation is dependent upon the reaction coupling and plate coupling. An advantage of this set is that it will operate efficiently over a considerable range of wave-length and antenna resistances.

**42. A MODULATED TRANSMITTER.**

The circuit for this set is given in Fig. 35. The instruments are the same as those described in Section 41, with

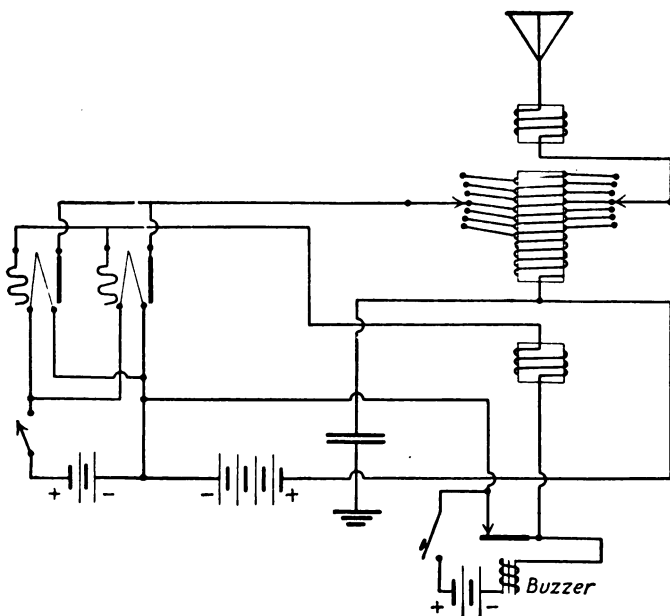

**Fig. 35.—Diagram of a Simple Modulated Undamped Wave-Transmitter.**

the addition of a buzzer, the vibrator of which is inserted in the grid circuit. When the filament switch is closed, undamped waves are radiated from the antenna. Operating the buzzer by means of the key puts a varying

charge on the grid of the tube, modulating the oscillations to form audio-frequency groups. While this method is not as efficient as the vacuum tube modulation, it is satisfactory for smaller sets.

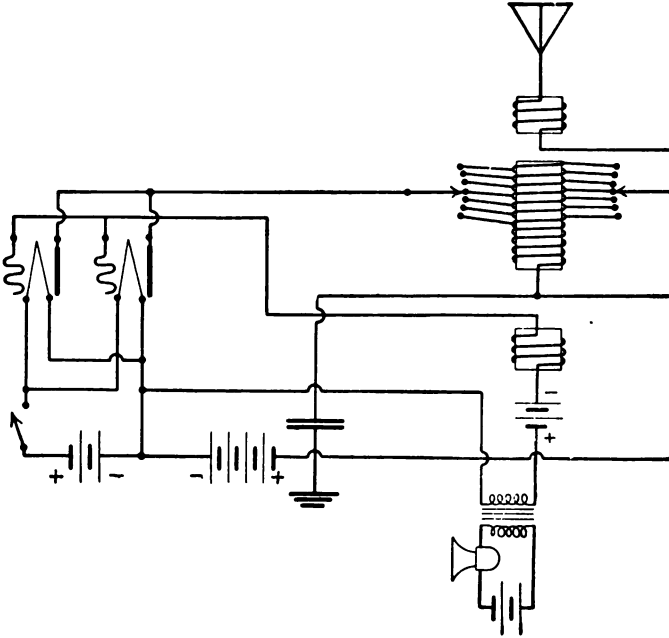

**Fig. 36.**—The Addition of a Telephone Modulator Makes Possible the Transmission of Speech.

#### 43. A TELEPHONE TRANSMITTER.

In Fig. 36 is a diagram of a telephone set, using instruments similar to those described in Section 41. A telephone transmitter and modulation transformer are employed to impress the voice frequencies on the grid circuit. For experimenting, a small open core transformer with a step up ratio of 1 to 10 can be employed. There are several good types of modulation transformers on the market.

An adjustable battery is inserted in the grid to adjust the voltage on the grid of the tube.

#### 44. ANOTHER TYPE OF TRANSMITTER.

A type of transmitter little known to experimenters is shown in Fig. 37. The main inductance is divided into four coils, wound close together on the same tube. In the middle are two coils in series with a variometer winding. As the diagram shows, they are in the antenna or radiating circuit. At one end there is a coil of 5 to 10 turns, con-

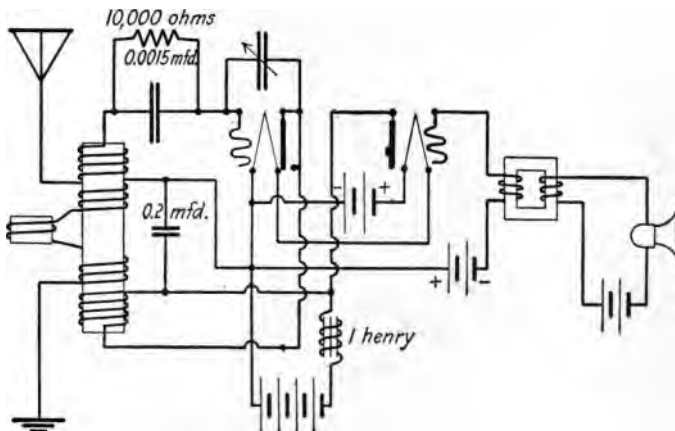
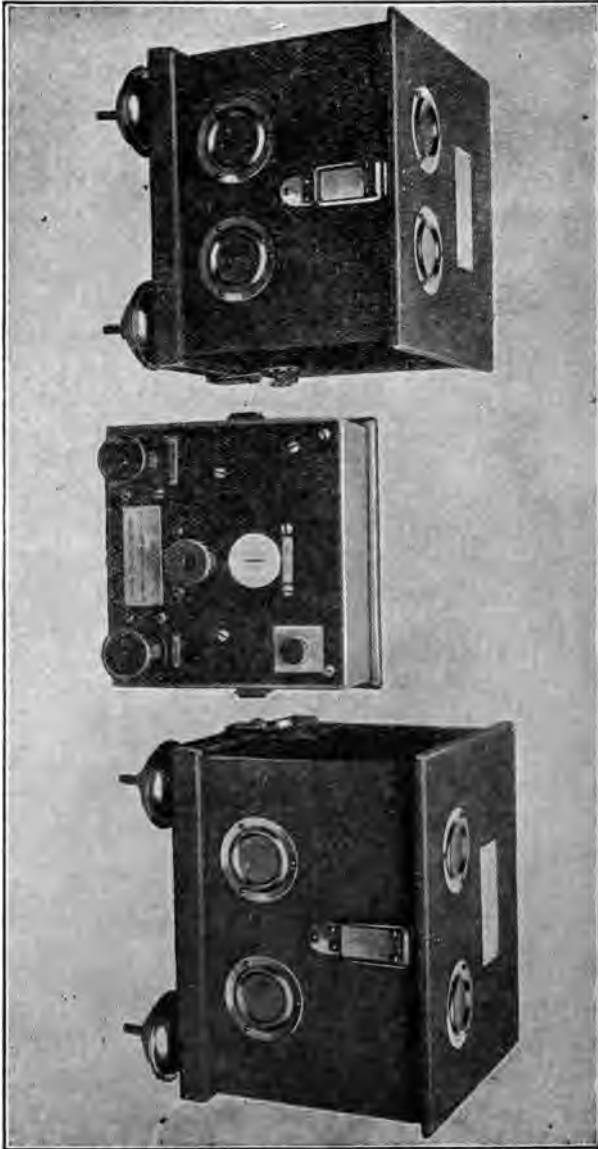

Fig. 37.—Another Circuit for a Wireless Telephone Set.

nected to the grid, and at the other end a coil of the same size, in the plate circuit.

All the tuning is done with the antenna coils, variometer, and a 0.0005 mfd. maximum variable condenser. This set will operate over a short range of wave-length and antenna capacities and resistances, maintaining a fairly constant output, a characteristic lacking in many circuits.

Modulation is effected by means of an auxillary tube. It will be seen that a modulation transformer is connected to the grid of the second tube. The plate current supply



**Fig. 38.—Western Electric Vacuum Tube Transmitting and Receiving Equipment.**

to both tubes passes through an iron core choke coil of about 1 henry. This coil, by reason of its high impedance, maintains the current at a constant amplitude. Therefore, when the current in the modulator tube is decreased by the application of a negative charge on its grid, from the modulation transformer, the current in the first or oscillator tube must increase, and *vice versa*. Thus the undamped waves are generated by the oscillations unmodulated at voice frequencies. This is the most efficient method.

This circuit can be used for undamped wave telegraphy by omitting the modulator or circuit and choke coil, or an oscillating circuit, of such constants as to produce audio-frequency note, can be connected in place of the transformer shown in Fig. 37. In that case, the choke coil should be left in the circuit.

#### 45. LOOP TRANSMITTERS.

Where a loop is to be used as an antenna, it can be in shunt with a variable air-condenser, across the antenna and ground posts. Another system sometimes used is to replace the inductance in Fig. 19 with a loop, taking the center tap from the middle of the loop as is done on the coil.





**LATEST**  
**REVISED**  
**CATALOGUE**

*of the Best*

**Practical and Mechanical Books**

**Including Automobile and Aviation Books**



**PRACTICAL BOOKS FOR PRACTICAL MEN**

Each Book in this Catalogue is written by an  
Expert and is written so you can understand it

---

PUBLISHED BY

**THE NORMAN W. HENLEY PUBLISHING CO.**

**2 West 45th Street, New York, U. S. A.**

*Established 1890*

 **Any Book in this Catalogue sent prepaid on receipt of price**

*Manuscripts solicited on Practical Subjects*

# INDEX

	PAGE		PAGE
Abrasives and Abrasive Wheels	29	Lathe Work	23
Accidents	25	Link Motions	24
Air Brakes	24, 26	Liquid Air	24
Arithmetic	13, 27, 37	Locomotive Boilers	25
Automobile Books	3, 4, 5, 6	Locomotive Breakdowns	25
Automobile Charts	6, 7	Locomotive Engineering	24, 25, 26
Automobile Ignition Systems	7	Machinist Books	27, 28, 29
Automobile Lighting	4	Manual Training	30
Automobile Questions and Answers	5	Marine Engineering	30
Automobile Repairing	5	Marine Gasoline Engines	21
Automobile Starting Systems	4	Mechanical Drawing	13
Automobile Trouble Charts	6, 7	Mechanical Movements	28
Automobile Welding	6	Metal Work	12
Aviation	8	Model Making	29
Bells, Electric	14	Motor Boats	30
Bevel Gear	21	Motorcycles	7, 31
Boats, Motor	30	Motor Truck	3
Boiler Room Chart	9	Naval Engineering	30
Boilers, Marine	30	Patents	22
Brazing	9	Pattern Making	31
Cams	21	Perfumery	32
Carburetion Trouble Charts	7	Perspective	13
Carburetors	4	Plumbing	32, 33
Car Charts	9	Punches	12
Cements	12	Producer Gas	21
Change Gear	21	Questions and Answers on Automobile	5
Charts	6, 7, 9	Questions on Heating	38
Chemistry	10	Radio Time Signal Receiver	16, 17
Coal	24	Railroad Accidents	25
Combustion	19	Railroad Charts	9
Concrete	10, 11, 12	Recipe Book	34
Concrete for Farm Use	11	Refrigeration	22
Concrete for Shop Use	11	Repairing Automobiles	5
Cosmetics	32	Rope Work	23
Dictionary	12, 17	Rubber	35
Dies	12	Rubber Stamps	35
Drawing	13, 32	Saw Filing	35
Drawing for Plumbers	32	Saws, Management of	35
Dynamo Building	14	Screw Cutting	35
Electric Bells	14	Shipbuilders' Pocket Book	30
Electric Dictionary	17	Shop Construction	27
Electric Switchboards	15	Shop Management	27
Electric Toy Making	16	Shop Practice	27, 28, 29
Electric Wiring	15	Shop Tools	29
Electricity	13, 14, 15, 16, 17, 18	Sketching Paper	13
Electroplating	19	Slide Valve	24
Encyclopedia	29	Soldering	9
Engine, Aviation	8	Splices and Rope Work	23
E-T Air Brake	26	Steam Engineering	35, 36, 37
Factory Management	19	Steam Heating	37
Ford Automobile	4	Steel	38
Ford Tractor	4	Storage Batteries	18
Ford Trouble Chart	7	Submarine Chart	9
Formulas and Recipes	34	Switchboards	15
Fuel	19	Tapers	23
Gas Engines	20, 21	Telegraphy, Wireless	14, 16, 18
Gas Tractor	30	Telephone	18
Gearing and Cams	21	Thread-Cutting	27
Glossary Aviation Terms	8	Tool Making	27
Heating	37	Tool Steel	38
High Frequency Apparatus	15	Toy Making	16
Horse-Power Chart	36	Tractive Power Chart	9
Hot Water Heating	57	Tractor, Gas	39
House Wiring	17, 18	Train Rules	26
Hydraulics	22	Vacuum Heating	38
Ice	22	Valve Setting	24
Ignition Systems	4	Ventilation	37
Ignition Trouble Chart	7	Walschaert Valve Gear	26
India Rubber	35	Waterproofing	12
Interchangeable Manufacturing	27	Welding	6, 30
Inventions	22	Wireless Telegraphy	14, 16, 18
Kerosene Carburetors	4	Wiring	15, 17, 18
Knots	23	Wiring Diagrams	15

**Any of these books promptly sent prepaid to any address in the world on receipt of price.**  
**HOW TO REMIT.—By Postal Money Order, Express Money Order, Bank Draft or Registered Letter.**

## CATALOGUE OF GOOD, PRACTICAL BOOKS

### AUTOMOBILES

#### **THE MODERN GASOLINE AUTOMOBILE—ITS DESIGN, CONSTRUCTION, MAINTENANCE AND REPAIR** By VICTOR W. PAGÉ, M.E.

The latest and most complete treatise on the Gasoline Automobile ever issued. Written in simple language by a recognized authority, familiar with every branch of the automobile industry. Free from technical terms. Everything is explained so simply that anyone of average intelligence may gain a comprehensive knowledge of the gasoline automobile. The information is up-to-date and includes, in addition to an exposition of principles of construction and description of all types of automobiles and their components, valuable money-saving hints on the care and operation of motor-cars propelled by internal combustion engines. Among some of the subjects treated might be mentioned: Torpedo and other symmetrical body forms designed to reduce air resistance; sleeve valve, rotary valve and other types of silent motors; increasing tendency to favor worm-gear power-transmission; universal application of magneto ignition; development of automobile electric-lighting systems; block motors; underslung chassis; application of practical self-starters; long stroke and offset cylinder motors; latest automatic lubrication systems; silent chains for valve operation and change-speed gearing; the use of front wheel brakes and many other detail refinements. By a careful study of the pages of this book one can gain practical knowledge of automobile construction that will save time, money and worry. The book tells you just what to do, how and when to do it. Nothing has been omitted, no detail has been slighted. Every part of the automobile, its equipment, accessories, tools, supplies, spare parts necessary, etc., have been discussed comprehensively. If you are or intend to become a motorist, or are in any way interested in the modern Gasoline Automobile, this is a book you cannot afford to be without. 1032 pages— and more than 1,000 new and specially made detail illustrations, as well as many full-page and double-page plates, showing all parts of the automobile. Including 12 large folding plates. New Edition. Price **\$4.00**

#### WHAT IS SAID OF THIS BOOK:

"It is the best book on the Automobile seen up to date."—J. H. Pile, Associate Editor *Automobile Trade Journal*.

"Every Automobile Owner has use for a book of this character."—*The Tradesman*.

"This book is superior to any treatise heretofore published on the subject."—*The Inventive Age*.

"We know of no other volume that is so complete in all its departments, and in which the wide field of automobile construction with its mechanical intricacies is so plainly handled, both in the text and in the matter of illustrations."—*The Motorist*.

"The book is very thorough, a careful examination failing to disclose any point in connection with the automobile, its care and repair, to have been overlooked."—*Iron Age*.

"Mr. Pagé has done a great work, and benefit to the Automobile Field."—W. C. Hasford, Mgr. Y. M. C. A. Automobile School, Boston, Mass.

"It is just the kind of a book a motorist needs if he wants to understand his car."—*American Thresherman*.

#### **THE MODERN MOTOR TRUCK, ITS DESIGN, CONSTRUCTION, OPERATION AND REPAIR.** By VICTOR W. PAGÉ.

Just off the press and treats on all types of motor trucks and industrial tractors and trailers. It considers all types of trucks, gasoline and electric, and all varieties of truck bodies. This book is written in language everyone can understand and is not in any sense of the word a technical treatise. It is a practical volume that will make special appeal to the truck driver who seeks to better his position and to the mechanic charged with the repair and upkeep of trucks. The factory or business executive who wants to obtain a complete working knowledge of truck operation problems will find this book a reference work of great value. The truck salesman or automobile dealer will find that this work contains information that means money to them. All garage and service station men should have a copy of this book for reference because truck construction differs from passenger car design in many important respects. Anyone who reads this book is in touch with all the practical features that have been tested out in real service. 1921 Edition. Cloth, 6 x 9, 962 pages, 750 illustrations. Price **\$5.00**

## CATALOGUE OF GOOD, PRACTICAL BOOKS

---

---

### THE MODEL T FORD CAR, ITS CONSTRUCTION, OPERATION AND REPAIR, INCLUDING THE FORDSON FARM TRACTOR, F. A. LIGHTING AND STARTING SYSTEM, FORD MOTOR TRUCK. By VICTOR W. PAGÉ.

This is the most complete and practical instruction book ever published on the Ford car and Fordson tractor. All parts of the Ford Model T car and Fordson tractor are described and illustrated in a comprehensive manner. The constructor fully treated and operating principle made clear to everyone. Complete instructions for driving and repairing are given. To the New Revised Edition matter has been added on the Ford Truck and Tractor Conversion Sets and Genuine Fordson Tractor. All parts are described. All repair processes illustrated and fully explained. Write so all can understand—no theory, no guesswork. New revised and enlarged Edition just published. 153 illustrations, 410 pages, 2 large folding plates. Price **\$2**

### AUTOMOBILE STARTING, LIGHTING AND IGNITION SYSTEMS.

VICTOR W. PAGÉ, M.E.

This practical volume has been written with special reference to the requirements of non-technical reader desiring easily understood, explanatory matter, relating to types of automobile ignition, starting and lighting systems. It can be understood by anyone, even without electrical knowledge, because elementary electrical principles considered before any attempt is made to discuss features of the various systems. These basic principles are clearly stated and illustrated with simple diagrams. All leading systems of starting, lighting and ignition have been described and illustrated with the co-operation of the experts employed by the manufacturers. Wiring diagrams shown in both technical and non-technical forms. All symbols are fully explained. This is a comprehensive review of modern starting and ignition system practice, and includes a complete exposition of storage battery construction, care and repair. All types of starting motors, generators, magnetos, and all ignition or lighting system units are fully explained. The systems of cars already in use as well as those that are to be considered. *Every person in the automobile business needs this volume.* 5 1/2 x 7 1/2 Cloth. 815 pages, 492 illustrations, 3 folding plates. New revised and enlarged edition. Price **\$3**

### GASOLINE AND KEROSENE CARBURETORS, CONSTRUCTION, INSTALLATION AND ADJUSTMENT. By VICTOR W. PAGÉ. A new up-to-date Book on Modern Carburetion Practice.

This is a simple, comprehensive, and authoritative treatise for practical men explaining all basic principles pertaining to carburetion, showing how liquid fuels are vaporized and turned into gas for operating all types of internal combustion engines intended to operate on vapors of gasoline, kerosene, benzol, and alcohol. All leading types of carburetors are described in detail, special attention being given to the forms devised to use the cheaper fuels such as kerosene. Carburetion troubles, fuel system trouble carburetor repairs and installation, electric primers and economizers, hot spot methods and all modern carburetor developments are considered in a thorough manner. Methods of adjusting all types of carburetors are fully discussed as well as suggestions for securing maximum fuel economy and obtaining highest engine power. This book is invaluable to repairmen, students, and motorists, as it includes the most complete exposition on kerosene carburetors ever published. The drawings showing carburetor construction are made from accurate engineering designs and show all parts of late types of carburetors. 213 pages. 89 illustrations. **\$2**

### HINTS AND TIPS FOR AUTOMOBILISTS. By VICTOR W. PAGÉ.

The book is ideal for the busy man or woman who wants to know about car operation and upkeep because of the economies possible when an automobile is intelligently operated. It contains many money-saving hints and a brief simple exposition of location and remedy of roadside troubles apt to occur under ordinary operating conditions. Price **75 cts**

## CATALOGUE OF GOOD, PRACTICAL BOOKS

### **AUTOMOBILE REPAIRING MADE EASY.** By VICTOR W. PAGÉ, M.E.

A comprehensive, practical exposition of every phase of modern automobile repairing practice. Outlines every process incidental to motor car restoration. Gives plans for workshop construction, suggestions for equipment, power needed, machinery and tools necessary to carry on the business successfully. Tells how to overhaul and repair all parts of all automobiles. Everything is explained so simply that motorists and students can acquire a full working knowledge of automobile repairing. This work starts with the engine, then considers carburetion, ignition, cooling and lubrication systems. The clutch, change-speed gearing and transmission system are considered in detail. Contains instructions for repairing all types of axles, steering gears and other chassis parts. Many tables, short cuts in figuring and rules of practice are given for the mechanic. Explains fully valve and magneto timing, "tuning" engines, systematic location of trouble, repair of ball and roller bearings, shop kinks, first aid to injured and a multitude of subjects of interest to all in the garage and repair business.

*This book contains special instructions on electric starting, lighting and ignition systems, fire repairing and rebuilding, autogenous welding, brazing and soldering, heat treatment of steel, latest timing practice, eight and twelve-cylinder motors, etc.* 5¼x8. Cloth. 1060 pages, 1,000 illustrations, 11 folding plates. Price. . . . . **\$4.00**

#### WHAT IS SAID OF THIS BOOK:

"'Automobile Repairing Made Easy' is the best book on the subject I have ever seen and the only book I ever saw that is of any value in a garage."—Fred Jeffrey, Martinsburg, Neb.

"I wish to thank you for sending me a copy of 'Automobile Repairing Made Easy.' I do not think it could be excelled."—S. W. Gisriel, Director of Instruction, Y. M. C. A., Philadelphia, Pa.

### **QUESTIONS AND ANSWERS RELATING TO MODERN AUTOMOBILE CONSTRUCTION, DRIVING AND REPAIR.** By VICTOR W. PAGÉ, M.E.

A practical self-instructor for students, mechanics and motorists, consisting of thirty-seven lessons in the form of questions and answers, written with special reference to the requirements of the non-technical reader desiring easily understood, explanatory matter relating to all branches of automobiling. The subject-matter is absolutely correct and explained in simple language. If you can't answer all of the following questions, you need this work. The answers to these and nearly 2000 more are to be found in its pages. Give the name of all important parts of an automobile and describe their functions? Describe action of latest types of kerosene carburetors? What is the difference between a "double" ignition system and a "dual" ignition system? Name parts of an induction coil? How are valves timed? What is an electric motor starter and how does it work? What are advantages of worm drive gearing? Name all important types of ball and roller bearings? What is a "three-quarter" floating axle? What is a two-speed axle? What is the Vulcan electric gear shift? Name the causes of lost power in automobiles? Describe all noises due to deranged mechanism and give causes? How can you adjust a carburetor by the color of the exhaust gases? What causes "popping" in the carburetor? What tools and supplies are needed to equip a car? How do you drive various makes of cars? What is a differential lock and where is it used? Name different systems of wire wheel construction, etc., etc. A popular work at a popular price. 5¼x7½. Cloth. 701 pages, 387 illustrations, 3 folding plates. New revised edition. Price **\$2.50**

#### WHAT IS SAID OF THIS BOOK:

"If you own a car—get this book."—*The Glassworker.*

"Mr. Pagé has the faculty of making difficult subjects plain and understandable."—*Bristol Press.*

"We can name no writer better qualified to prepare a book of instruction on automobiles than Mr. Victor W. Pagé."—*Scientific American.*

"The best automobile catechism that has appeared."—*Automobile Topics.*

"There are few men, even with long experience, who will not find this book useful. Great pains have been taken to make it accurate. Special recommendation must be given to the illustrations, which have been made specially for the work. Such excellent books as this greatly assist in fully understanding your automobile."—*Engineering News.*

## CATALOGUE OF GOOD, PRACTICAL BOOKS

---

---

### HOW TO RUN AN AUTOMOBILE. By VICTOR W. PAGÉ.

This treatise gives concise instructions for starting and running all makes of gasoline automobiles, how to care for them, and gives distinctive features of control. Describes every step for shifting gears, controlling engine, etc. Among the chapters contained are: I. Automobile Parts and Their Functions. II. General Starting and Driving Instructions. III. Control Systems—Care of Automobiles. Thoroughly illustrated. 178 pages. 72 illustrations. Price . . . . . \$1.50

### THE AUTOMOBILIST'S POCKET COMPANION AND EXPENSE RECORD By VICTOR W. PAGÉ.

This book is not only valuable as a convenient cost record, but contains much information of value to motorists. Includes a condensed digest of auto laws of all States, a lubrication schedule, hints for care of storage battery, and care of tires, location of road troubles, anti-freezing solutions, horse-power table, driving hints and many useful tables and recipes of interest to all motorists. Not a technical book in any sense of the word, just a collection of practical facts in simple language for the every-day motorist. Convenient pocket size. Price . . . . . \$1.50

### AUTOMOBILE WELDING WITH THE OXY-ACETYLENE FLAME. By M. KEITH DUNHAM.

Explains in a simple manner apparatus to be used, its care, and how to construct necessary shop equipment. Proceeds then to the actual welding of all automobile parts in a manner understandable by everyone. Gives principles never to be forgotten. This book is of utmost value, since the perplexing problems arising when metal is heated to a melting point are fully explained and the proper methods to overcome them shown. 167 pages. Fully illustrated. Price . . . . . \$1.50

## AUTOMOBILE, AVIATION AND MOTORCYCLE CHART

---

---

### AVIATION CHART—LOCATION OF AIRPLANE POWER PLANT TROUBLE MADE EASY. By MAJOR VICTOR W. PAGÉ, A.S., S.C.U.S.R.

A large chart outlining all parts of a typical airplane power plant, showing the point where trouble is apt to occur and suggesting remedies for the common defects. Intended especially for aviators and aviation mechanics on school and field duty. Price . . . . . 35 cen

### CHART. GASOLINE ENGINE TROUBLES MADE EASY—A CHART SHOWING SECTIONAL VIEW OF GASOLINE ENGINE. Compiled by VICTOR W. PAGÉ, M.E.

It shows clearly all parts of a typical four-cylinder gasoline engine of the four-cycle type. It outlines distinctly all parts liable to give trouble and also details the arrangements apt to interfere with smooth engine operation. Valuable to students, motorists, mechanics, repairmen, garagemen, automobile salesmen, chauffeurs, motorboat owners, motor-truck and tractor drivers, aviators, motorcyclists, and all others who have to do with gasoline power plants. It simplifies location of all engine troubles, and while it will prove invaluable to the novice, it can be used to advantage by the more expert. It should be on the walls of every public and private garage, automobile repair shop, club house or school. It can be carried in the automobile or pocket with ease, and will insure against loss of time when engine trouble manifests itself. This sectional view of engine is a complete review of all motor troubles. It is prepared by a practical motorist for all who motor. More information for the money than ever before offered. No details omitted. Size 25x38 inches. Securely mailed on receipt of . . . . . 35 cent

## CATALOGUE OF GOOD, PRACTICAL BOOKS

---

---

### **CHART. LOCATION OF FORD ENGINE TROUBLES MADE EASY.** Compiled by VICTOR W. PAGÉ, M.E.

This shows clear sectional views depicting all portions of the Ford power plant and auxiliary groups. It outlines clearly all parts of the engine, fuel supply system, ignition group and cooling system, that are apt to give trouble, detailing all derangements that are liable to make an engine lose power, start hard or work irregularly. This chart is valuable to students, owners, and drivers as it simplifies location of all engine faults. Of great advantage as an instructor for the novice, it can be used equally well by the more expert as a work of reference and review. It can be carried in the toolbox or pocket with ease and will save its cost in labor eliminated the first time engine trouble manifests itself. Prepared with special reference to the average man's needs and is a practical review of all motor troubles because it is based on the actual experience of an automobile engineer-mechanic with the mechanism the chart describes. It enables the non-technical owner or operator of a Ford car to locate engine derangements by systematic search, guided by easily recognized symptoms instead of by guesswork. It makes the average owner independent of the roadside repair shop when touring. Must be seen to be appreciated. Size 25x38 inches. Printed on heavy bond paper. Price . . . . . **35 cents**

### **CHART. LUBRICATION OF THE MOTOR CAR CHASSIS.** Compiled by VICTOR W. PAGÉ, M.E.

This chart presents the plan view of a typical six-cylinder chassis of standard design and all parts are clearly indicated that demand oil, also the frequency with which they must be lubricated and the kind of oil to use. A practical chart for all interested in motor-car maintenance. Size 24x38 inches. Price . . . . . **35 cents**

### **CHART. LOCATION OF CARBURETION TROUBLES MADE EASY.** Compiled by VICTOR W. PAGÉ, M.E.

This chart shows all parts of a typical pressure feed fuel supply system and gives causes of trouble, how to locate defects and means of remedying them. Size 24x38 inches. Price . . . . . **35 cents**

### **CHART. LOCATION OF IGNITION SYSTEM TROUBLES MADE EASY.** Compiled by VICTOR W. PAGÉ, M.E.

In this diagram all parts of a typical double ignition system using battery and magneto current are shown, and suggestions are given for readily finding ignition troubles and eliminating them when found. Size 24x38 inches. Price . . . . . **35 cents**

### **CHART. LOCATION OF COOLING AND LUBRICATION SYSTEM FAULTS.** Compiled by VICTOR W. PAGÉ, M.E.

This composite diagram shows a typical automobile power plant using pump circulated water-cooling system and the most popular lubrication method. Gives suggestions for curing all overheating and loss of power faults due to faulty action of the oiling or cooling group. Size 24x38 inches. Price . . . . . **35 cents**

### **CHART. LOCATION OF STARTING AND LIGHTING SYSTEM FAULTS.**

The most complete chart yet devised, showing all parts of the modern automobile starting, lighting and ignition systems, giving instructions for systematic location of all faults in wiring, lamps, motor or generator, switches and all other units. Invaluable to motorists, chauffeurs and repairmen. Size 24x38 inches. Price . . . . . **35 cents**

### **CHART. MOTORCYCLE TROUBLES MADE EASY.** Compiled by VICTOR W. PAGÉ, M.E.

A chart showing sectional view of a single-cylinder gasoline engine. This chart simplifies location of all power-plant troubles. A single-cylinder motor is shown for simplicity. It outlines distinctly all parts liable to give trouble and also details the derangements apt to interfere with smooth engine operation. This chart will prove of value to all who have to do with the operation, repair or sale of motorcycles. No details omitted. Size 30x20 inches. Price . . . . . **35 cents**



# CATALOGUE OF GOOD, PRACTICAL BOOKS

## AVIATION

### A B C OF AVIATION. By MAJOR VICTOR W. PAGÉ.

This book describes the basic principles of aviation, tells how a balloon or dirigible is made and why it floats in the air. Describes how an airplane flies. It shows in detail the different parts of an airplane, what they are and what they do. Describes all types of airplanes and how they differ in construction; as well as detailing the advantages and disadvantages of different types of aircraft. It includes a complete dictionary of aviation terms and clear drawings of leading airplanes. The reader will find simple instructions for unpacking, setting up, and rigging airplanes. A full description of airplane control principles is given and methods of flying are discussed at length.

This book answers every question one can ask about modern aircraft, their construction and operation. A self-educator on aviation without an equal. 274 pages. 130 specially made illustrations with 7 plates. Price . . . . . \$2.50

### AVIATION ENGINES—DESIGN; CONSTRUCTION; REPAIR. By MAJOR VICTOR W. PAGÉ, A.S., S.C.U.S.R.

This treatise, written by a recognized authority on all of the practical aspects of internal combustion engine construction, maintenance, and repair, fills the need as no other book does. The matter is logically arranged; all descriptive matter is simply expressed and copiously illustrated, so that anyone can understand airplane engine operation and repair even if without previous mechanical training. This work is invaluable for anyone desiring to become an aviator or aviation mechanic. The latest rotary types, such as the Gnome Monosoupe, and LeRhone, are fully explained, as well as the recently developed Vee and radial types. The subjects of carburetion, ignition, cooling, and lubrication also are covered in a thorough manner. The chapters on repair and maintenance are distinctive and found in no other book on this subject. Not a technical book, but a practical, easily understood work of reference for all interested in aeronautical science. 589 pages. 253 illustrations. Price, net . . . . . \$8.00

### GLOSSARY OF AVIATION TERMS—ENGLISH-FRENCH; FRENCH-ENGLISH. By MAJOR VICTOR W. PAGÉ, A.S., S.C.U.S.R., and LIEUT. PAUL MONTARIOL, of the French Flying Corps.

A complete glossary of practically all terms used in aviation, having lists in both French and English with equivalents in either language. Price, net . . . \$1.00

### APPLIED AERODYNAMICS. By G. P. THOMPSON.

This is a scientific and mathematical treatise that has a special appeal to the student and engineer who are seeking exact information on the aerodynamics of heavier-than-air craft and data on airplane design testing. This book gives an up-to-date presentation of the existing state of Aeronautical Science. In addition to a very full discussion of the qualities which determine the speed and rate of climb of an aeroplane and the method by which they can be calculated, special attention is paid to stability—a problem now fairly well understood, and to controllability—our knowledge of which is at present in a much more elementary state. Attention is directed to the numerous directions in which further information is required, especially in the form of full-scale experiments. 312 pages (7 x 10). Illustrated with over 142 Diagrams and Graphic Charts. Price . . . . . \$12.50

### AVIATION CHART—LOCATION OF AIRPLANE POWER PLANT TROUBLES MADE EASY. By MAJOR VICTOR W. PAGÉ, A.S., S.C.U.S.R.

A large chart outlining all parts of a typical airplane power plant, showing the points where trouble is apt to occur and suggesting remedies for the common defects. Intended especially for aviators and aviation mechanics on school and field duty. Price . . . . . 35 cents

# CATALOGUE OF GOOD, PRACTICAL BOOKS

## BRAZING AND SOLDERING

### **BRAZING AND SOLDERING.** By JAMES F. HOBART.

The only book that shows you just how to handle any job of brazing or soldering that comes along; it tells you what mixture to use, how to make a furnace if you need one. Full of valuable kinks. The fifth edition of this book has just been published, and to it much new matter and a large number of tested formulae for all kinds of solders and fluxes have been added. Illustrated. . . . . **35 cents**

### **SOLDERING AND BRAZING.** By RAYMOND FRANCIS YATES.

This treatise gives all the necessary "kinks" that will enable one to accomplish successful soldering. If a mechanic has not succeeded in his soldering, this book may tell him just what he needs to produce good work—something that he may heretofore have forgotten. Price . . . . . **75 cents**

## CHARTS

### **MODERN SUBMARINE CHART.**

A cross-section view, showing clearly and distinctly all the interior of a Submarine of the latest type. You get more information from this chart, about the construction and operation of a Submarine, than in any other way. No details omitted—everything is accurate and to scale. All the machinery and devices fitted in a modern Submarine Boat are shown. . . . . **85 cents**

### **BOX CAR CHART.**

A chart showing the anatomy of a box car, having every part of the car numbered and its proper name given in a reference list. . . . . **35 cents**

### **GONDOLA CAR CHART.**

A chart showing the anatomy of a gondola car, having every part of the car numbered and its proper reference name given in a reference list. . . . . **35 cents**

### **PASSENGER-CAR CHART.**

A chart showing the anatomy of a passenger-car, having every part of the car numbered and its proper name given in a reference list. . . . . **35 cents**

### **STEEL HOPPER BOTTOM COAL CAR.**

A chart showing the anatomy of a steel Hopper Bottom Coal Car, having every part of the car numbered and its proper name given in a reference list. . . . . **35 cents**

### **TRACTIVE POWER CHART.**

A chart whereby you can find the tractive power or drawbar pull of any locomotive without making a figure. Shows what cylinders are equal, how driving wheels and steam pressure affect the power. What sized engine you need to exert a given drawbar pull or anything you desire in this line. . . . . **50 cents**

### **HORSE-POWER CHART**

Shows the horse-power of any stationary engine without calculation. No matter what the cylinder diameter of stroke, the steam pressure of cut-off, the revolutions, or whether condensing or non-condensing, it's all there. Easy to use, accurate, and saves time and calculations. Especially useful to engineers and designers. **50 cents**

### **BOILER ROOM CHART.** By GEO. L. FOWLER.

A chart—size 14x28 inches—showing in isometric perspective the mechanisms belonging in a modern boiler room. The various parts are shown broken or removed, so that the internal construction is fully illustrated. Each part is given a reference number, and these, with the corresponding name, are given in a glossary printed at the sides. . . . . **35 cents**

---

---

## CATALOGUE OF GOOD, PRACTICAL BOOKS

---

---

### CHEMISTRY

#### **HOW TO MAKE AND USE A SMALL CHEMICAL LABORATORY. By**

**RAYMOND FRANCIS YATES.**

The treatise covers all of the essentials of elementary chemistry. The law of definite proportions, solutions, crystalloids, colloids, electrolysis, etc., are explained. The second part of the book is devoted to chemical and electro-chemical experiments. Only those experiments that will tend to broaden the reader's knowledge of chemistry in general have been chosen. Price . . . . . **75 cents**

### CONCRETE

#### **JUST PUBLISHED—CONCRETE WORKERS' REFERENCE BOOKS. A SERIES OF POPULAR HANDBOOKS FOR CONCRETE USERS.**

Prepared by **A. A. HOUGHTON.** . . . . . Each **75 cents**

*The author, in preparing this Series, has not only treated on the usual types of construction, but explains and illustrates molds and systems that are not patented, but which are equal in value and often superior to those restricted by patents. These molds are very easily and cheaply constructed and embody simplicity, rapidity of operation, and the most successful results in the molded concrete. Each of these Twelve books is fully illustrated, and the subjects are exhaustively treated in plain English.*

#### **CONCRETE WALL FORMS. By A. A. HOUGHTON.**

A new automatic wall clamp is illustrated with working drawings. Other types of wall forms, clamps, separators, etc., are also illustrated and explained. (No. 1 of Series) . . . . . **75 cents**

#### **CONCRETE FLOORS AND SIDEWALKS. By A. A. HOUGHTON.**

The molds for molding squares, hexagonal and many other styles of mosaic floor and sidewalk blocks are fully illustrated and explained. (No. 2 of Series) . . . . . **75 cents**

#### **PRACTICAL CONCRETE SILO CONSTRUCTION. By A. A. HOUGHTON.**

Complete working drawings and specifications are given for several styles of concrete silos, with illustrations of molds for monolithic and block silos. The tables, data, and information presented in this book are of the utmost value in planning and constructing all forms of concrete silos. (No. 3 of Series) . . . . . **75 cents**

#### **MOLDING CONCRETE CHIMNEYS, SLATE AND ROOF TILES. By A. A. HOUGHTON.**

The manufacture of all types of concrete slate and roof tile is fully treated. Valuable data on all forms of reinforced concrete roofs are contained within its pages. The construction of concrete chimneys by block and monolithic systems is fully illustrated and described. A number of ornamental designs of chimney construction with molds are shown in this valuable treatise. (No. 4 of Series.) . . . . . **75 cents**

#### **MOLDING AND CURING ORNAMENTAL CONCRETE. By A. A. HOUGHTON.**

The proper proportions of cement and aggregates for various finishes, also the method of thoroughly mixing and placing in the molds, are fully treated. An exhaustive treatise on this subject that every concrete worker will find of daily use and value (No. 5 of Series.) . . . . . **75 cents**

#### **CONCRETE MONUMENTS, MAUSOLEUMS AND BURIAL VAULTS. By A. A. HOUGHTON.**

The molding of concrete monuments to imitate the most expensive cut stone is explained in this treatise, with working drawings of easily built molds. Cutting instructions and designs are also fully treated. (No. 6 of Series.) . . . . . **75 cents**

---

---

## CATALOGUE OF GOOD, PRACTICAL BOOKS

---

---

### **MOLDING CONCRETE BATHTUBS, AQUARIUMS AND NATATORIUMS.**

By A. A. HOUGHTON.

Simple molds and instruction are given for molding many styles of concrete bathtub, swimming-pools, etc. These molds are easily built and permit rapid and successful work. (No. 7 of Series.) . . . . . 75 cen

### **CONCRETE BRIDGES, CULVERTS AND SEWERS.** By A. A. HOUGHTON

A number of ornamental concrete bridges with illustrations of molds are given. collapsible center or core for bridges, culverts and sewers is fully illustrated with detailed instructions for building. (No. 8 of Series.) . . . . . 75 cen

### **CONSTRUCTING CONCRETE PORCHES.** By A. A. HOUGHTON.

A number of designs with working drawings of molds are fully explained so anyone can easily construct different styles of ornamental concrete porches without the purchase of expensive molds. (No. 9 of Series.) . . . . . 75 cen

### **MOLDING CONCRETE FLOWER-POTS, BOXES, JARDINIÈRES, ETC.**

By A. A. HOUGHTON.

The molds for producing many original designs of flower-pots, urns, flower-boxes, jardinières, etc., are fully illustrated and explained, so the worker can easily construct and operate same. (No. 10 of Series.) . . . . . 75 cen

### **MOLDING CONCRETE FOUNTAINS AND LAWN ORNAMENTS.** By A. HOUGHTON.

A. HOUGHTON.

The molding of a number of designs of lawn seats, curbing, hitching posts, pergolas, sundials and other forms of ornamental concrete for the ornamentation of lawns and gardens, is fully illustrated and described. (No. 11 of Series) . . . . . 75 cen

### **CONCRETE FROM SAND MOLDS.** By A. A. HOUGHTON.

A Practical Work treating on a process which has heretofore been held as a trade secret by the few who possessed it, and which will successfully mold every and any class of ornamental concrete work. The process of molding concrete with sand molds is the utmost practical value, possessing the manifold advantages of a low cost of mold, the ease and rapidity of operation, perfect details to all ornamental designs, denseness and increased strength of the concrete, perfect curing of the work without attention and the easy removal of the molds regardless of any undercutting the design may have. 192 pages. Fully illustrated. Price . . . . . \$2.00

### **ORNAMENTAL CONCRETE WITHOUT MOLDS.** By A. A. HOUGHTON

The process for making ornamental concrete without molds has long been held as a secret, and now, for the first time, this process is given to the public. The book reveals the secret and is the only book published which explains a simple, practical method whereby the concrete worker is enabled, by employing wood and metal templates of different designs, to mold or model in concrete any Cornice, Architrave, Column, Pedestal, Base Cap, Urn or Pier in a monolithic form—right upon the job. These may be molded in units or blocks, and then built up to suit the specification demanded. This work is fully illustrated, with detailed engravings. Price . \$2.00

### **CONCRETE FOR THE FARM AND IN THE SHOP.** By H. COL

CAMPBELL, C.E., E.M.

A new book illustrating and describing in plain, simple language many of the numerous applications of concrete within the range of the home worker. Among the subjects treated are:

Principles of reinforcing; methods of protecting concrete so as to insure proper hardening; home-made mixers; mixing by hand and machine; form construction, describing and illustrated by drawings and photographs; construction of concrete walls and fences; concrete fence posts; concrete gate posts; corner posts; clothes line post; grape arbor posts; tanks; troughs; cisterns; hog wallows; feeding floors and barnyard pavements; foundations; well curbs and platforms; indoor floors; sidewalks; step concrete notches and cold frames; concrete slab roofs; walls for buildings; repair of leaks in tanks and cisterns, etc., etc. A number of convenient and practical tables for estimating quantities, and some practical examples, are also given. (5 x 7 1/2 inches) 149 pages, 51 illustrations. Price . . . . . \$1.00

## CATALOGUE OF GOOD, PRACTICAL BOOKS

---

---

### POPULAR HANDBOOK FOR CEMENT AND CONCRETE USERS. By MYRON H. LEWIS.

This is a concise treatise of the principles and methods employed in the manufacture and use of cement in all classes of modern works. The author has brought together in this work all the salient matter of interest to the user of concrete and its many diversified products. The matter is presented in logical and systematic order, clearly written, fully illustrated and free from involved mathematics. Everything of value to the concrete user is given, including kinds of cement employed in construction, concrete architecture, inspection and testing, waterproofing, coloring and painting, rules, tables, working and cost data. The book comprises thirty-three chapters, 430 pages, 126 illustrations. Price . . . . . \$3.00

### WATERPROOFING CONCRETE. By MYRON H. LEWIS.

Modern Methods of Waterproofing Concrete and Other Structures. A condensed statement of the Principles, Rules, and Precautions to be Observed in Waterproofing and Dampproofing Structures and Structural Materials. Price . . . . . 75 cents

## DICTIONARIES

### STANDARD ELECTRICAL DICTIONARY. By T. O'CONNOR SLOANE.

An indispensable work to all interested in electrical science. Suitable alike for the student and professional. A practical handbook of reference containing definitions in about 5000 distinct words, terms and phrases. The definitions are terse and concise and include every term used in electrical science. Recently issued. An entirely new edition. Should be in the possession of all who desire to keep abreast with the progress of this branch of science. Complete, concise and convenient. Nearly 800 pages. Nearly 500 illustrations. New Revised and Enlarged Edition. Price . . . . . \$5.00

## DIES—METAL WORK

### DIES: THEIR CONSTRUCTION AND USE FOR THE MODERN WORKING OF SHEET METALS. By J. V. WOODWORTH.

A most useful book, and one which should be in the hands of all engaged in the press-working of metals; treating on the Designing, Constructing, and Use of Tools, Fixtures and Devices, together with the manner in which they should be used in the Power Press, for the cheap and rapid production of the great variety of sheet-metal articles now in use. It is designed as a guide to the production of sheet-metal parts at the minimum of cost with the maximum of output. The hardening and tempering of Press tools and the classes of work which may be produced to the best advantage by the use of dies in the power press are fully treated. Its 505 illustrations show dies, press fixtures and sheet-metal working devices, the descriptions of which are so clear and practical that all metal-working mechanics will be able to understand how to design, construct and use them. Many of the dies and press fixtures treated were either constructed by the author or under his supervision. Others were built by skillful mechanics and are in use in large sheet-metal establishments and machine shops. 6th Edition. 400 pages, 523 illustrations. Price . . . . . \$3.50

### PUNCHES, DIES AND TOOLS FOR MANUFACTURING IN PRESSES. By J. V. WOODWORTH.

This work is a companion volume to the author's elementary work entitled "Dies, Their Construction and Use." It does not go into the details of die-making to the extent of the author's previous book, but gives a comprehensive review of the field of operations carried on by presses. A large part of the information given has been drawn from the author's personal experience. It might well be termed an Encyclopedia of Die-Making, Punch-Making, Die-Sinking, Sheet-Metal Working, and Making of Special Tools, Sub-presses, Devices and Mechanical Combinations for Punching, Cutting, Bending, Forming, Piercing, Drawing, Compressing and Assembling Sheet-Metal Parts, and also Articles of other Materials in Machine Tools. 3rd Edition. 483 pages, 702 illustrations. Price . . . . . \$4.50

**CATALOGUE OF GOOD, PRACTICAL BOOKS**

**DRAWING—SKETCHING PAPER**

**PRACTICAL PERSPECTIVE.** By RICHARDS and COLVIN.

Shows just how to make all kinds of mechanical drawings in the only practical perspective isometric. Makes everything plain so that any mechanic can understand a sketch or drawing in this way. Saves time in the drawing room, and mistakes in shops. Contains practical examples of various classes of work. 4th Edition. 75 cts

**LINEAR PERSPECTIVE SELF-TAUGHT.** By HERMAN T. C. KRAUS

This work gives the theory and practice of linear perspective, as used in architectural engineering and mechanical drawings. Persons taking up the study of the subject by themselves will be able, by the use of the instruction given, to readily grasp subject, and by reasonable practice become good perspective draftsmen. The arrangement of the book is good; the plate is on the left-hand, while the descriptive follows on the opposite page, so as to be readily referred to. The drawings are sufficiently large scale to show the work clearly and are plainly figured. They include a self-explanatory chart which gives all information necessary for the thorough understanding of perspective. This chart alone is worth many times over the price of the book. 2d Revised and enlarged Edition. . . . . \$1

**SELF-TAUGHT MECHANICAL DRAWING AND ELEMENTARY MACHINE DESIGN.** By F. L. SYLVESTER, M.E., Draftsman, with additions by E. OBERG, associate editor of "Machinery."

This is a practical treatise on Mechanical Drawing and Machine Design, comprising the first principles of geometric and mechanical drawing, workshop mathematics, mechanics, strength of materials and the calculations and design of machine details. The author's aim has been to adapt this treatise to the requirements of the practical mechanic and young draftsman and to present the matter in as clear and concise a manner as possible. To meet the demands of this class of students, practically all important elements of machine design have been dealt with, and in addition algebraic formulas have been explained, and the elements of trigonometry treated in the manner best suited to the needs of the practical man. The book is divided into 20 chapters and in arranging the material, mechanical drawing, pure and simple, has been treated up first, as a thorough understanding of the principles of representing objects facilitates the further study of mechanical subjects. This is followed by the mathematics necessary for the solution of the problems in machine design which are presented later, a practical introduction to theoretical mechanics and the strength of materials. . . . . various elements entering into machine design, such as cams, gears, sprocket-wheel, cone pulleys, bolts, screws, couplings, clutches, shafting and fly-wheels, have been treated in such a way as to make possible the use of the work as a text-book for a continuous course of study. 335 pages, 218 engravings. Price . . . . . \$2

**A NEW SKETCHING PAPER.**

A new specially ruled paper to enable you to make sketches or drawings in isometric perspective without any figuring or fussing. It is being used for shop details as well as for assembly drawings, as it makes one sketch do the work of three, and no work can help seeing just what is wanted. Pads of 40 sheets, 6x9 inches, 40 cents. Pads of 40 sheets, 9x12 inches, 75 cents; 40 sheets, 12x18, Price . . . . . \$1

**ELECTRICITY**

**ARITHMETIC OF ELECTRICITY.** By Prof. T. O'CONNOR SLOANE.

A practical treatise on electrical calculations of all kinds reduced to a series of rules of the simplest forms, and involving only ordinary arithmetic: each rule illustrated by one or more practical problems, with detailed solution of each one. This book is classed among the most useful works published on the science of electricity, covers as it does the mathematics of electricity in a manner that will attract the attention of those who are not familiar with algebraical formulas. 22nd Edition. 196 pages. Price . . . . . \$1

## CATALOGUE OF GOOD, PRACTICAL BOOKS

---

### COMMUTATOR CONSTRUCTION. By WM. BAXTER, JR.

The business end of any dynamo or motor of the direct current type is the commutator. This book goes into the designing, building, and maintenance of commutators, shows how to locate troubles and how to remedy them; everyone who fusses with dynamos needs this. 5th Edition . . . . . 35 cents

### CONSTRUCTION OF A TRANSATLANTIC WIRELESS RECEIVING SET.

By L. G. PACENT and T. S. CURTIS.

A work for the Radio student who desires to construct and operate apparatus that will permit of the reception of messages from the large stations in Europe with an aerial of amateur proportions. 36 pages. 23 illustrations, cloth. Price . 35 cents

### DYNAMO BUILDING FOR AMATEURS, OR HOW TO CONSTRUCT A FIFTY-WATT DYNAMO. By ARTHUR J. WEED, Member of N. Y. Electrical Society.

A practical treatise showing in detail the construction of a small dynamo or motor, the entire machine work of which can be done on a small foot lathe. Dimensioned working drawings are given for each piece of machine work, and each operation is clearly described. This machine, when used as a dynamo, has an output of fifty watts; when used as a motor it will drive a small drill press or lathe. It can be used to drive a sewing machine on any and all ordinary work. The book is illustrated with more than sixty original engravings showing the actual construction of the different parts. Among the contents are chapters on: 1. Fifty-Watt Dynamo. 2. Side Bearing Rods. 3. Field Punching. 4. Bearings. 5. Commutator. 6. Pulley. 7. Brush Holders. 8. Connection Board. 9. Armature Shaft. 10. Armature. 11. Armature Winding. 12. Field Winding. 13. Connecting and Starting. Price, cloth, \$1.00

### DESIGN DATA FOR RADIO TRANSMITTERS AND RECEIVERS. By MILTON B. SLEEPER.

Far from being a collection of formulas, Design Data takes up in proper sequence the problems encountered in planning all types of receiving sets for short, medium and long wave work, and spark coil, transformer and vacuum tube transmitters operating on 200 meters. Tables have been worked out so that values can be found without the use of mathematics. Radio experimenters will find here information which will enable them to have the most modern and efficient equipment. Price . . 75 cents

### DYNAMOS AND ELECTRIC MOTORS AND ALL ABOUT THEM. By EDWARD TREVERT.

This volume gives practical directions for building a two H. P. Dynamo of the Edison type capable of lighting about fifty mazda lamps of the 20-watt size. In addition, it gives directions for building two small electric motors suitable for running sewing machines. The concluding chapter describes the construction of a simple bichromate battery adapted for running electric motors. 96 pages. Fully illustrated with detail drawings. Cloth. Price . . . . . \$1.00

### ELECTRIC BELLS. By M. B. SLEEPER.

A complete treatise for the practical worker in installing, operating, and testing bell circuits, burglar alarms, thermostats, and other apparatus used with electric bells. Both the electrician and the experimenter will find in this book new material which is essential in their work. Tools, bells, batteries, unusual circuits, burglar alarms, annunciators, systems, thermostats, circuit breakers, time alarms, and other apparatus used in bell circuits are described from the standpoints of their application, construction, and repair. The detailed instructions for building the apparatus will appeal to the experimenter particularly. The practical worker will find the chapters on Wiring Calculation of Wire Sizes and Magnet Windings, Upkeep of Systems and the Location of Faults of the greatest value in their work. 124 pages. Fully illustrated. Price . . . . . 75 cents

## CATALOGUE OF GOOD, PRACTICAL BOOKS

### EXPERIMENTAL HIGH FREQUENCY APPARATUS — HOW TO MAKE AND USE IT. By THOMAS STANLEY CURTIS.

This book tells you how to build simple high frequency coils for experimental purpose in the home, school laboratory, or on the small lecture platform. The book is really a supplement to the same author's "High Frequency Apparatus." The experimental side only is covered in this volume, which is intended for those who want to build small coils giving up to an eighteen-inch spark. The book contains valuable information for the physicist or the manual training teacher who is on the lookout for interesting projects for his boys to build or experiment with. The apparatus is simple, cheap and perfectly safe, and with it some truly startling experiments may be performed. Among the contents are: Induction Coil Outfits Operated on Battery Current. Kicking Coil Apparatus. One-Half Kilowatt Transformer Outfit. Parts and Materials, etc., etc. 69 pages. Illustrated. Price . . . . . 50 cents

### HIGH FREQUENCY APPARATUS, ITS CONSTRUCTION AND PRACTICAL APPLICATION. By THOMAS STANLEY CURTIS.

The most comprehensive and thorough work on this interesting subject ever produced. The book is essentially practical in its treatment and it constitutes an accurate record of the researches of its author over a period of several years, during which time dozens of coils were built and experimented with. The work has been divided into six basic parts. The first two chapters tell the uninitiated reader what the high frequency current is, what it is used for, and how it is produced. The second section, comprising four chapters, describes in detail the principles of the transformer, condenser, spark gap, and oscillation transformer, and covers the main points in the design and construction of these devices as applied to the work in hand. The third section covers the construction of small high frequency outfits designed for experimental work in the home laboratory or in the classroom. The fourth section is devoted to electro-therapeutic and X-Ray apparatus. The fifth describes apparatus for the cultivation of plants and vegetables. The sixth section is devoted to a comprehensive discussion of apparatus of large size for use upon the stage in spectacular productions. The closing chapter, giving the current prices of the parts and materials required for the construction of the apparatus described, is included with a view to expediting the purchase of the necessary goods. The Second Edition includes much new matter along the line of home-made therapeutic outfits for physicians' use. The matter on electro plant culture has also been elaborated upon. Second Revised and Enlarged Edition. 266 pages. New second edition. Fully illustrated. Price . \$3.00

### ELECTRIC WIRING, DIAGRAMS AND SWITCHBOARDS. By NEWTON HARRISON.

A thoroughly practical treatise covering the subject of Electric Wiring in all its branches, including explanations and diagrams which are thoroughly explicit and greatly simplify the subject. Practical, every-day problems in wiring are presented and the method of obtaining intelligent results clearly shown. Only arithmetic is used. Ohm's law is given a simple explanation with reference to wiring for direct and alternating currents. The fundamental principle of drop of potential in circuits is shown with its various applications. The simple circuit is developed with the position of mains, feeders and branches; their treatment as a part of a wiring plan and their employment in house wiring clearly illustrated. Some simple facts about testing are included in connection with the wiring. Molding and conduit work are given careful consideration; and switchboards are systematically treated, built up and illustrated, showing the purpose they serve, for connection with the circuits, and to shunt and compound wound machines. The simple principles of switchboard construction, the development of the switchboard, the connections of the various instruments, including the lightning arrester, are also plainly set forth.

Alternating current wiring is treated, with explanations of the power factor, conditions calling for various sizes of wire, and a simple way of obtaining the sizes for single-phase, two-phase and three-phase circuits. This is the only complete work issued showing and telling you what you should know about direct and alternating current wiring. It is a ready reference. The work is free from advanced technicalities and mathematics, arithmetic being used throughout. It is in every respect a handy, well-written, instructive, comprehensive volume on wiring for the wireman, foreman, contractor, or electrician. 3rd edition, revised and enlarged. 315 pages; 137 illustrations. Price . . . . . \$2.50



## CATALOGUE OF GOOD, PRACTICAL BOOKS

### ELECTRIC TOY MAKING, DYNAMO BUILDING, AND ELECTRIC MOTOR CONSTRUCTION. By Prof. T. O'CONNOR SLOANE.

This work treats of the making at home of electrical toys, electrical apparatus, motors, dynamos and instruments in general, and is designed to bring within the reach of young and old the manufacture of genuine and useful electrical appliances. The work is especially designed for amateurs and young folks.

Thousands of our young people are daily experimenting, and busily engaged in making electrical toys and apparatus of various kinds. The present work is just what is wanted to give the much needed information in a plain, practical manner, with illustrations to make easy the carrying out of the work. 20th Edition. 210 pages, 77 illustrations. Price . . . . . \$1.50

### ELECTRICIANS' HANDY BOOK. By Prof. T. O'CONNOR SLOANE.

This work is intended for the practical electrician who has to make things go. The entire field of electricity is covered within its pages. Among some of the subjects treated are: The Theory of the Electric Current and Circuit, Electro-Chemistry, Primary Batteries, Storage Batteries, Generation and Utilization of Electric Powers, Alternating Current, Armature Winding, Dynamos and Motors, Motor Generators, Operation of the Central Station Switchboards, Safety Appliances, Distribution of Electric Light and Power, Street Mains, Transformers, Arc and Incandescent Lighting, Electric Measurements, Photometry, Electric Railways, Telephony, Bell-Wiring, Electric-Plating, Electric Heating, Wireless Telegraphy, etc. It contains no useless theory; everything is to the point. It teaches you just what you want to know about electricity. It is the standard work published on the subject. Forty-six chapters, 600 engravings. New 5th Edition, Revised and Enlarged. Price \$4.00

### ELECTRICITY SIMPLIFIED. By Prof. T. O'CONNOR SLOANE.

The object of "Electricity Simplified" is to make the subject as plain as possible and to show what the modern conception of electricity is; to show how two plates of different metal, immersed in acid, can send a message around the globe; to explain how a bundle of copper wire rotated by a steam engine can be the agent in lighting our streets, to tell what the volt, ohm and ampere are, and what high and low tension mean; and to answer the questions that perpetually arise in the mind in this age of electricity. 15th Revised Edition. 218 pages. Illustrated. Price . . . \$1.50

### EXPERIMENTAL WIRELESS STATIONS. By P. E. EDELMAN.

The theory, design, construction and operation is fully treated including Wireless Telephony, Vacuum Tube, and quenched spark systems. The new enlarged edition is just issued and is strictly up to date, correct and complete. This book tells how to make apparatus to not only hear all telephoned and telegraphed radio messages, but also how to make simple equipment that works for transmission over reasonably long distances. Then there is a host of new information included. The first and only book to give you all the recent important radio improvements, some of which have never before been published. This volume anticipates every need of the reader who wants the gist of the art, its principles, simplified calculations, apparatus dimensions, and understandable directions for efficient operation. Vacuum tube circuits; amplifiers; long-distance sets; loop, coil, and underground receivers; tables of wave-lengths, capacity, inductance; such are a few of the subjects presented in detail that satisfies. It is independent and one of the few that describe all modern systems.

Endorsed by foremost instructors for its clear accuracy, preferred by leading amateurs for its dependable designs. The new experimental Wireless Stations is sure to be most satisfactory for your purposes. 27 chapters, 392 pages, 167 illustrations. Price . . . . . \$3.00

### RADIO TIME SIGNAL RECEIVER. By AUSTIN C. LESCARBOURA.

This new book, "A Radio Time Signal Receiver," tells you how to build a simple outfit designed expressly for the beginner. You can build the outfits in your own workshop and install them for jewelers either on a one-payment or a rental basis. The apparatus is of such simple design that it may be made by the average amateur mechanic possessing a few ordinary tools. 42 pages. Paper. Price . . . 85 cents

## CATALOGUE OF GOOD, PRACTICAL BOOKS

### HOUSE WIRING. By THOMAS W. POPPE.

This work describes and illustrates the actual installation of Electric Light Wiring, the manner in which the work should be done, and the method of doing it. The book can be conveniently carried in the pocket. It is intended for the Electrician, Helper, and Apprentice. It solves all Wiring Problems and contains nothing that conflicts with the rulings of the National Board of Fire Underwriters. It gives just the information essential to the Successful Wiring of a Building. Among the subjects treated are Locating the Meter. Panel Boards. Switches. Plug Receptacles. Brackets. Ceiling Fixtures. The Meter Connections. The Feed Wires. The Steel Armored Cable System. The Flexible Steel Conduit System. The Rigid Conduit System. A digest of the National Board of Fire Underwriters' rules relating to metallic wiring systems. Various switching arrangements explained and diagrammed. The easiest method of testing the Three- and Four-way circuits explained. The grounding of all metallic wiring systems and the reason for doing so shown and explained. The insulation of the metal parts of lamp fixtures and the reason for the same described and illustrated. 208 pages. 4th Edition, revised and enlarged. 160 illustrations. Flexible cloth. Price . . . . . \$1.00

### HOW TO BECOME A SUCCESSFUL ELECTRICIAN. By Prof. T. O'CONNOR SLOANE.

Every young man who wishes to become a successful electrician should read this book. It tells in simple language the surest and easiest way to become a successful electrician. The studies to be followed, methods of work, field of operation and the requirement, of the successful electrician are pointed out and fully explained. Every young engineer will find this an excellent stepping stone to more advanced works on electricity which he must master before success can be attained. Many young men become discouraged at the very outstart by attempting to read and study books that are far beyond their comprehension. This book serves as the connecting link between the rudiments taught in the public schools and the real study of electricity. It is interesting from cover to cover. 19th Revised Edition, just issued. 205 pages. Illustrated. Price . . . . . \$1.50

### RADIO HOOK-UPS. By MILTON B. SLEEPER.

In this book the best circuits for different instruments and various purposes have been carefully selected and grouped together. All the best circuits for damped and undamped wave receiving sets, buzzer, spark coil and transformer sending equipment, as well as vacuum tube telegraph and telephone transmitters, wavemeters, vacuum tube measuring instruments, audibility meters, etc., are shown in this book. . 75 cents

### STANDARD ELECTRICAL DICTIONARY. By T. O'CONNOR SLOANE.

An indispensable work to all interested in electrical science. Suitable alike for the student and professional. A practical handbook of reference containing definitions of about 5,000 distinct words, terms and phrases. The definitions are terse and concise and include every term used in electrical science. Recently issued. An entirely new edition. Should be in the possession of all who desire to keep abreast with the progress of this branch of science. In its arrangement and typography the book is very convenient. The word or term defined is printed in black-faced type which readily catches the eye, while the body of the page is in smaller but distinct type. The definitions are well worded, and so as to be understood by the non-technical reader. The general plan seems to be to give an exact, concise definition, and then amplify and explain in a more popular way. Synonyms are also given, and references to other words and phrases are made. A very complete and accurate index of fifty pages is at the end of the volume; and as this index contains all synonyms, and as all phrases are indexed in every reasonable combination of words, reference to the proper place in the body of the book is readily made. It is difficult to decide how far a book of this character is to keep the dictionary form, and to what extent it may assume the encyclopedia form. For some purposes, concise, exactly worded definitions are needed; for other purposes, more extended descriptions are required. This book seeks to satisfy both demands, and does it with considerable success. Complete, concise and convenient. 800 pages. Nearly 500 illustrations. New Revised and Enlarged Edition. Price . . . . . \$5.00

## CATALOGUE OF GOOD, PRACTICAL BOOKS

### STORAGE BATTERIES SIMPLIFIED. By VICTOR W. PAGÉ, M.S.A.E.

A complete treatise on storage battery operating principles, repairs and applications. The greatly increasing application of storage batteries in modern engineering and mechanical work has created a demand for a book that will consider this subject completely and exclusively. This is the most thorough and authoritative treatise ever published on this subject. It is written in easily understandable, non-technical language so that anyone may grasp the basic principles of storage battery action as well as their practical industrial applications. All electric and gasoline automobiles use storage batteries. Every automobile repairman, dealer or salesman should have a good knowledge of maintenance and repair of these important elements of the motor car mechanism. This book not only tells how to charge, care for and rebuild storage batteries but also outlines all the industrial uses. Learn how they run street cars, locomotives and factory trucks. Get an understanding of the important functions they perform in submarine boats, isolated lighting plants, railway switch and signal systems, marine applications, etc. This book tells how they are used in central station standby service, for starting automobile motors and in ignition systems. Every practical use of the modern storage battery is outlined in this treatise. 208 pages. Fully illustrated. Price . . . . . \$2.00

### TELEPHONE CONSTRUCTION, INSTALLATION, WIRING, OPERATION AND MAINTENANCE. By W. H. RADCLIFFE and H. C. CUSHING.

This book is intended for the amateur, the wireman, or the engineer who desires to establish a means of telephonic communication between the rooms of his home, office, or shop. It deals only with such things as may be of use to him rather than with theories.

Gives the principles of construction and operation of both the Bell and Independent instruments; approved methods of installing and wiring them; the means of protecting them from lightning and abnormal currents; their connection together for operation as series or bridging stations; and rules for their inspection and maintenance. Line wiring and the wiring and operation of special telephone systems are also treated.

Intricate mathematics are avoided, and all apparatus, circuits and systems are thoroughly described. The appendix contains definitions of units and terms used in the text. Selected wiring tables, which are very helpful, are also included. Among the subjects treated are Construction, Operation, and Installation of Telephone Instruments; Inspection and Maintenance of Telephone Instruments; Telephone Line Wiring; Testing Telephone Line Wires and Cables; Wiring and Operation of Special Telephone Systems, etc. 2nd Edition, revised and enlarged. 223 pages. 154 illustrations . . . . . \$1.50

### WIRELESS TELEGRAPHY AND TELEPHONY SIMPLY EXPLAINED. By ALFRED P. MORGAN.

This is undoubtedly one of the most complete and comprehensible treatises on the subject ever published, and a close study of its pages will enable one to master all the details of the wireless transmission of messages. The author has filled a long-felt want and has succeeded in furnishing a lucid, comprehensible explanation in simple language of the theory and practice of wireless telegraphy and telephony.

Among the contents are: Introductory; Wireless Transmission and Reception—The Aerial System, Earth Connections—The Transmitting Apparatus, Spark Coils and Transformers, Condensers, Helixes, Spark Gaps, Anchor Gaps, Aerial Switches—The Receiving Apparatus, Detectors, etc.—Tuning and Coupling, Tuning Coils, Loose Couplers, Variable Condensers, Directive Wave Systems—Miscellaneous Apparatus, Telephone Receivers, Range of Stations, Static Interference—Wireless Telephones, Sound and Sound Waves, The Vocal Cords and Ear—Wireless Telephone. How Sounds Are Changed into Electric Waves—Wireless Telephones, The Apparatus—Summary. 154 pages. 156 engravings. Price . . . . . \$1.50

### WIRING A HOUSE. By HERBERT PRATT.

Shows a house already built; tells just how to start about wiring it; where to begin; what wire to use; how to run it according to Insurance Rules; in fact, just the information you need. Directions apply equally to a shop. Fourth edition . . . . . 35 cents

## CATALOGUE OF GOOD, PRACTICAL BOOKS

---

---

### ELECTROPLATING

#### **THE MODERN ELECTROPLATER.** By KENNETH M. COGGESHALL.

This is one of the most complete and practical books on electroplating and allied processes that has been published as a text for the student or professional plater. It is written in simple language and explains all details of electroplating in a concise yet complete manner. It starts at the beginning and gives an elementary outline of electricity and chemistry as relates to plating, then considers shop layout and equipment and gives all the necessary information to do reliable and profitable electroplating in a modern commercial manner. Full instructions are given for the preparation and finishing of the work and formulae and complete directions are included for making all kinds of plating solutions, many of these having been trade secrets until published in this instruction manual. Anyone interested in practical plating and metal finishing will find this book a valuable guide and complete manual of the art. Cloth. 142 illustrations. 276 pages. Price . . . . . \$3.00

### FACTORY MANAGEMENT, ETC.

#### **MODERN MACHINE SHOP CONSTRUCTION, EQUIPMENT AND MANAGEMENT.** By O. E. PERRIGO, M.E.

The only work published that describes the modern machine shop or manufacturing plant from the time the grass is growing on the site intended for it until the finished product is shipped. By a careful study of its thirty-six chapters the practical man may economically build, efficiently equip, and successfully manage the modern machine shop or manufacturing establishment. Just the book needed by those contemplating the erection of modern shop buildings, the rebuilding and reorganization of old ones, or the introduction of modern shop methods, time and cost systems. It is a book written and illustrated by a practical shop man for practical shop men who are too busy to read *theories* and want *facts*. It is the most complete all-around book of its kind ever published. It is a practical book for practical men, from the apprentice in the shop to the president in the office. It minutely describes and illustrates the most simple and yet the most efficient time and cost system yet devised. 384 pages. 219 illustrations. Price . . . . . \$5.00

### FUEL

#### **COMBUSTION OF COAL AND THE PREVENTION OF SMOKE.** By Wm. M. BARR.

This book has been prepared with special reference to the generation of heat by the combustion of the common fuels found in the United States, and deals particularly with the conditions necessary to the economic and smokeless combustion of bituminous coals in Stationary and Locomotive Steam Boilers.

The presentation of this important subject is systematic and progressive. The arrangement of the book is in a series of practical questions to which are appended accurate answers, which describe in language, free from technicalities, the several processes involved in the furnace combustion of American fuels; it clearly states the essential requisites for perfect combustion, and points out the best methods for furnace construction for obtaining the greatest quantity of heat from any given quality of coal. 5th Edition. Nearly 350 pages, fully illustrated. Price. . . . \$1.50

## CATALOGUE OF GOOD, PRACTICAL BOOKS

### GAS AND OIL ENGINES

#### **THE GASOLINE ENGINE ON THE FARM: ITS OPERATION, REPAIR AND USES.** By XENO W. PUTNAM.

This is a practical treatise on the Gasoline and Kerosene Engine intended for the man who wants to know just how to manage his engine and how to apply it to all kinds of farm work to the best advantage.

This book abounds with hints and helps for the farm and suggestions for the home and housewife. There is so much of value in this book that it is impossible to adequately describe it in such small space. Suffice to say that it is the kind of a book every farmer will appreciate and every farm home ought to have. Includes selecting the most suitable engine for farm work, its most convenient and efficient installation, with chapters on troubles, their remedies, and how to avoid them. The care and management of the farm tractor in plowing, harrowing, harvesting and road grading are fully covered; also plain directions are given for handling the tractor on the road. Special attention is given to relieving farm life of its drudgery by applying power to the disagreeable small tasks which must otherwise be done by hand. Many home-made contrivances for cutting wood, supplying kitchen, garden, and barn with water, loading, hauling and unloading hay, delivering grain to the bins or the feed trough are included; also full directions for making the engine milk the cows, churn, wash, sweep the house and clean the windows, etc. Very fully illustrated with drawings of working parts and cuts showing Stationary, Portable and Tractor Engines doing all kinds of farm work. All money-making farms utilize power. Learn how to utilize power by reading the pages of this book. It is an aid to the result getter, invaluable to the up-to-date farmer, student, blacksmith, implement dealer and, in fact, all who can apply practical knowledge of stationary gasoline engines or gas tractors to advantage. 530 pages. Nearly 180 engravings. Price . . . . . \$3.00

#### **GASOLINE ENGINES: THEIR OPERATION, USE AND CARE.** By A. HYATT VERRILL.

The simplest, latest and most comprehensive popular work published on Gasoline Engines, describing what the Gasoline Engine is; its construction and operation; how to install it; how to select it; how to use it and how to remedy troubles encountered. Intended for Owners, Operators and Users of Gasoline Motors of all kinds. This work fully describes and illustrates the various types of Gasoline Engines used in Motor Boats, Motor Vehicles and Stationary Work. The parts, accessories and appliances are described, with chapters on ignition, fuel, lubrication, operation and engine troubles. Special attention is given to the care, operation and repair of motors, with useful hints and suggestions on emergency repairs and makeshifts. A complete glossary of technical terms and an alphabetically arranged table of troubles and their symptoms form most valuable and unique features of this manual. Nearly every illustration in the book is original, having been made by the author. Every page is full of interest and value. A book which you cannot afford to be without. 275 pages. 152 specially made engravings. Price . . . . . \$2.00

#### **GAS, GASOLINE, AND OIL ENGINES.** By GARDNER D. HISCOX.

Just issued, 23d revised and enlarged edition. Every user of a gas engine needs this book. Simple, instructive, and right up-to-date. The only complete work on the subject. Tells all about the running and management of gas, gasoline and oil engines, as designed and manufactured in the United States. Explosive motors for stationary marine and vehicle power are fully treated, together with illustrations of their parts and tabulated sizes, also their care and running are included. Electric ignition by induction coil and jump spark are fully explained and illustrated, including valuable information on the testing for economy and power and the erection of power plants.

The rules and regulations of the Board of Fire Underwriters in regard to the installation and management of gasoline motors are given in full, suggesting the safe installation of explosive motor power. A list of United States Patents issued on gas, gasoline, and oil engines and their adjuncts from 1875 to date is included. 640 pages. 435 engravings. Folding plates. Price . . . . . \$8.00

## CATALOGUE OF GOOD, PRACTICAL BOOKS

### **GAS ENGINES AND PRODUCER-GAS PLANTS.** By R. E. MATHOT, M.E.

This is a practical treatise, setting forth the principles of gas engine and producer design, the selection and installation of an engine, conditions of perfect operation, producer-gas engines and their possibilities; the care of gas engines and producer-gas plants, with a chapter on volatile hydrocarbon and oil engines. A practical guide for the gas engine designer, user and engineer in the construction, selection, purchase, installation, operation and maintenance of gas engines. *Every part of the gas engine is described in detail, tersely, clearly and with a thorough understanding of the requirements of the mechanic.* Recognizing the need of a volume that would assist the gas engine user in understanding the motor upon which he depends for power, the author has discussed the subject without the help of any mathematics. Helpful suggestions as to the purchase of an engine, its installation, care and operation, form a most valuable feature of the book. 6 x 9 inches. Cloth. 314 pages. 152 illustrations. Price. **\$.3.00**

### **GAS ENGINE CONSTRUCTION, OR HOW TO BUILD A HALF-HORSE-POWER GAS ENGINE.** By PARSELL and WEED.

A practical treatise of 300 pages describing the theory and principles of the action of Gas Engines of various types and the design and construction of a half-horse-power Gas Engine, with illustrations of the work in actual progress, together with the dimensioned working drawings, giving clearly the sizes of the various details: for the student, the scientific investigator, and the amateur mechanic. This book treats of the subject more from the standpoint of practice than that of theory. The principles of operation of Gas Engines are clearly and simply described, and then the actual construction of a half-horse-power engine is taken up, step by step, showing in detail the making of the Gas Engine. 3d Edition. 300 pages. Price . . . . . **\$.3.00**

### **HOW TO RUN AND INSTALL GASOLINE ENGINES.** By C. VON CULIN.

Revised and enlarged edition just issued. The object of this little book is to furnish a pocket instructor for the beginner, the busy man who uses an engine for pleasure or profit, but who does not have the time or inclination for a technical book, but simply to thoroughly understand how to properly operate, install and care for his own engine. The index refers to each trouble, remedy, and subject alphabetically. Being a quick reference to find the cause, remedy and prevention for troubles, and to become an expert with his own engine. Pocket size. Paper binding. Price . . . . . **25 cents**

## GEARING AND CAMS

### **BEVEL GEAR TABLES.** By D. AG. ENGSTROM.

A book that will at once commend itself to mechanics and draftsmen. Does away with all the trigonometry and fancy figuring on bevel gears, and makes it easy for anyone to lay them out or make them just right. There are 36 full-page tables that show every necessary dimension for all sizes or combinations you're apt to need. No puzzling, figuring or guessing. Gives placing distance, all the angles (including cutting angles), and the correct cutter to use. A copy of this prepares you for anything in the bevel-gear line. 3d Edition. 66 pages. . . . . **\$1.50**

### **CHANGE GEAR DEVICES.** By OSCAR E. PERRIGO.

A practical book for every designer, draftsman, and mechanic interested in the invention and development of the devices for feed changes on the different machines requiring such mechanism. All the necessary information on this subject is taken up, analyzed, classified, sifted, and concentrated for the use of busy men who have not the time to go through the masses of irrelevant matter with which such a subject is usually encumbered and select such information as will be useful to them.

It shows just what has been done, how it has been done, when it was done, and who did it. It saves time in hunting up patent records and re-inventing old ideas. 3rd Edition. 101 pages . . . . . **\$1.50**

### **DRAFTING OF CAMS.** By LOUIS ROUILLION.

The laying out of cams is a serious problem unless you know how to go at it right. This puts you on the right road for practically any kind of cam you are likely to run up against. 3d Edition. . . . . **85 cents**

## CATALOGUE OF GOOD, PRACTICAL BOOKS

---

### HYDRAULICS

#### **HYDRAULIC ENGINEERING.** By GARDNER D. HISCOX.

A treatise on the properties, power, and resources of water for all purposes. Including the measurement of streams, the flow of water in pipes or conduits; the horse-power of falling water, turbine and impact water-wheels, wave motors, centrifugal, reciprocating and air-lift pumps. With 300 figures and diagrams and 36 practical tables. All who are interested in water-works development will find this book a useful one, because it is an entirely practical treatise upon a subject of present importance, and cannot fail in having a far-reaching influence, and for this reason should have a place in the working library of every engineer. Among the subjects treated are: Historical Hydraulics, Properties of Water, Measurement of the Flow of Streams; Flowing Water Surface Orifices and Nozzles; Flow of Water in Pipes; Siphons of Various Kinds; Dams and Great Storage Reservoirs; City and Town Water Supply; Wells and Their Reinforcement; Air Lift Methods of Raising Water; Artesian Wells, Irrigation of Arid Districts; Water Power; Water-Wheels; Pumps and Pumping Machinery; Reciprocating Pumps; Hydraulic Power Transmission; Hydraulic Mining; Canals; Dredges; Conduits and Pipe Lines; Marine Hydraulics; Tidal and Sea Wave Power, etc. 320 pages. Price . . . . . \$4.50

### ICE AND REFRIGERATION

#### **POCKETBOOK OF REFRIGERATION AND ICE MAKING.** By A. J. WALLIS-TAYLOR.

This is one of the latest and most comprehensive reference books published on the subject of refrigeration and cold storage. It explains the properties and refrigerating effect of the different fluids in use, the management of refrigerating machinery and the construction and insulation of cold rooms with their required pipe surface for different degrees of cold; freezing mixtures and non-freezing brines, temperatures of cold rooms for all kinds of provisions, cold storage charges for all classes of goods, ice making and storage of ice, data and memoranda for constant reference by refrigerating engineers, with nearly one hundred tables containing valuable references to every fact and condition required in the installment and operation of a refrigerating plant. New edition just published. Price . . . . . \$2.00

### INVENTIONS—PATENTS

#### **INVENTORS' MANUAL, HOW TO MAKE A PATENT PAY.**

This is a book designed as a guide to inventors in perfecting their inventions, taking out their patents and disposing of them. It is not in any sense a Patent Solicitor's Circular nor a Patent Broker's Advertisement. No advertisements of any description appear in the work. It is a book containing a quarter of a century's experience of a successful inventor, together with notes based upon the experience of many other inventors.

Among the subjects treated in this work are: How to Invent, How to Secure a Good Patent, Value of Good Invention, How to Exhibit an Invention, How to Interest Capital, How to Estimate the Value of a Patent, Value of Design Patents, Value of Foreign Patents, Value of Small Inventions, Advice on Selling Patents, Advice on the Formation of Stock Companies, Advice on the Formation of Limited Liability Companies, Advice on Disposing of Old Patents, Advice as to Patent Attorneys, Advice as to Selling Agents, Forms of Assignments, License and Contracts, State Laws Concerning Patent Rights, 1900 Census of the United States by Counts of Over 10,000 Population. New revised and enlarged edition. 144 pages, illustrated. Price . . . . . \$1.50

**CATALOGUE OF GOOD, PRACTICAL BOOKS**

---

---

**KNOTS**

**KNOTS, SPLICES AND ROPE WORK.** By A. HYATT VERRILL.

This is a practical book giving complete and simple directions for making all the most useful and ornamental knots in common use, with chapters on Splicing, Pointing, Seizing, Servicing, etc. This book is fully illustrated with one hundred and fifty original engravings, which show how each knot, tie or splice is formed, and its appearance when finished. The book will be found of the greatest value to Campers, Yacht men, Travelers, Boy Scouts, in fact, to anyone having occasion to use or handle rope or knots for any purpose. The book is thoroughly reliable and practical, and is not only a guide, but a teacher. It is the standard work on the subject. Among its contents are: 1. Cordage, Kinds of Rope, Construction of Rope, Parts of Rope, Cable and Bolt Rope, Strength of Rope, Weight of Rope. 2. Simple Knots and Bends. Terms Used in Handling Rope, Seizing Rope. 3. Ties and Hitches. Noose, Loops and Mooring Knots. 4. Shortenings, Grommets and Salvages. Lashings, Seizings and Splices. 5. Fancy Knots and Rope Work. 104 pages. 11 original engravings. Price . . . . . \$1.00

**LATHE WORK**

**LATHE DESIGN, CONSTRUCTION, AND OPERATION, WITH PRACTICAL EXAMPLES OF LATHE WORK.** By OSCAR E. PERRIGO.

A new revised edition, and the only complete American work on the subject, written by a man who knows not only how work ought to be done, but who also knows how to do it, and how to convey this knowledge to others. It is strictly up-to-date in its descriptions and illustrations. Lathe history and the relations of the lathe to manufacturing are given; also a description of the various devices for feeds and their cutting mechanisms from early efforts in this direction to the present time. Lathe design is thoroughly discussed, including back gearing, driving cones, thread-cutting gears, and all the essential elements of the modern lathe. The classification of lathes is taken up, giving the essential differences of the several types of lathes including as is usually understood, engine lathes, bench lathes, speed lathes, forge lathes, gear lathes, pulley lathes, forming lathes, multiple-spindle lathes, rapid-reduction lathes, precision lathes, turret lathes, special lathes, electrically-driven lathes, etc. In addition to the complete exposition on construction and design, much practical matter on lathe installation, care and operation has been incorporated in the enlarged 1915 edition. All kinds of lathe attachments for drilling, milling, etc., are described as complete instructions are given to enable the novice machinist to grasp the art of lathe operation as well as the principles involved in design. A number of difficult machining operations are described at length and illustrated. The new edition has nearly 500 pages and 350 illustrations. Price . . . . . \$3.00

**LATHE WORK FOR BEGINNERS.** By RAYMOND FRANCIS YATES.

A simple, straightforward text-book for those desiring to learn the operation of wood-turning or metal-turning lathe. The first chapter tells how to choose a lathe and all of the standard types on the market are described. Simple and more advanced lathe work is thoroughly covered and the operation of all lathe attachments such as millers, grinders, polishers, etc., is described. The treatment starts from the very bottom and leads the reader through to a point where he will be able to handle the larger commercial machines with very little instruction. The last chapter of the book is devoted to things to make on the lathe and includes a model rapid-fire navy gun. This is the only book published in this country that treats lathe work from the standpoint of the amateur mechanic. 162 illustrations. About 250 pages, 12mo. Price . . . . . \$2.00

**TURNING AND BORING TAPERS.** By FRED H. COLVIN.

There are two ways to turn tapers; the right way and one other. This treatise tells you to do with the right way; it tells you how to start the work properly, how to set the lathe, what tools to use and how to use them, and forty and one other little things that you should know. Fifth edition. Price . . . . . 35 cent



# CATALOGUE OF GOOD, PRACTICAL BOOKS

---

---

## LIQUID AIR

### **LIQUID AIR AND THE LIQUEFACTION OF GASES.** By T. O'CONOR SLOANE.

This book gives the history of the theory, discovery, and manufacture of Liquid Air, and contains an illustrated description of all the experiments that have excited the wonder of audiences all over the country. It shows how liquid air, like water, is carried hundreds of miles and is handled in open buckets. It tells what may be expected from it in the near future.

A book that renders simple one of the most perplexing chemical problems of the century. Startling developments illustrated by actual experiments.

It is not only a work of scientific interest and authority, but is intended for the general reader, being written in a popular style—easily understood by everyone. Third edition. Revised and Enlarged. 394 pages. New Edition. Price . . . **\$8.00**

## LOCOMOTIVE ENGINEERING

### **AIR-BRAKE CATECHISM.** By ROBERT H. BLACKALL.

This book is a standard text-book. It covers the Westinghouse Air-Brake Equipment, including the No. 5 and the No. 6 E. T. Locomotive Brake Equipment; the K (Quick Service) Triple Valve for Freight Service; and the Cross-Compound Pump. The operation of all parts of the apparatus is explained in detail, and a practical way of finding their peculiarities and defects, with a proper remedy, is given. It contains 2,000 questions with their answers, which will enable any railroad man to pass any examination on the subject of Air Brakes. Endorsed and used by air-brake instructors and examiners on nearly every railroad in the United States. 28th Edition. 411 pages, fully illustrated with colored plates and diagrams. Price . . . . . **\$2.50**

### **COMBUSTION OF COAL AND THE PREVENTION OF SMOKE.** By Wm. M. BARR.

This book has been prepared with special reference to the generation of heat by the combustion of the common fuels found in the United States and deals particularly with the conditions necessary to the economic and smokeless combustion of bituminous coal in Stationary and Locomotive Steam Boilers.

Presentation of this important subject is systematic and progressive. The arrangement of the book is in a series of practical questions to which are appended accurate answers, which describe in language free from technicalities the several processes involved in the furnace combustion of American fuels; it clearly states the essential requisites for perfect combustion, and points out the best methods of furnace construction for obtaining the greatest quantity of heat from any given quality of coal. Nearly 350 pages, fully illustrated. Price . . . . . **\$1.50**

### **DIARY OF A ROUND-HOUSE FOREMAN.** By T. S. REILLY.

This is the greatest book of railroad experiences ever published. Containing a fund of information and suggestions along the line of handling men, organizing, etc., that one cannot afford to miss. 158 pages. Price . . . . . **\$1.50**

### **LINK MOTIONS, VALVES AND VALVE SETTING.** By FRED H. COLVIN, Associate Editor of *American Machinist*.

A handy book for the engineer or machinist that clears up the mysteries of valve setting. Shows the different valve gears in use, how they work, and why. Piston and slide valves of different types are illustrated and explained. A book that every railroad man in the motive power department ought to have. Contains chapters on Locomotive Link Motion, Valve Movements, Setting Slide Valves, Analysis by Diagrams, Modern Practice, Slip of Block, Slice Valves, Piston Valves, Setting Piston Valves, Joy-Allen Valve Gear, Walschaert Valve Gear, Gooch Valve Gear, Allfree-Hubbell Valve Gear, etc., etc. 3rd Edition, 101 pages. Fully illustrated. Price **75 cents**

## CATALOGUE OF GOOD, PRACTICAL BOOKS

### LOCOMOTIVE BOILER CONSTRUCTION. By FRANK A. KLEINHANS.

The construction of boilers in general is treated, and, following this, the locomotive boiler is taken up in the order in which its various parts go through the shop. Shows all types of boilers used; gives details of construction; practical facts, such as life of riveting, punches and dies; work done per day, allowance for bending and flanging sheets, and other data. Including the recent Locomotive Boiler Inspection Law and Examination Questions with their answers for Government Inspectors. Contains chapters on Laying Out Work; Flanging and Forging; Punching; Shearing; Plate Planing; General Tables; Finishing Parts; Bending; Machinery Parts; Riveting Boiler Details; Smoke Box Details; Assembling and Calking; Boiler Shop Machinery, etc., etc.

There isn't a man who has anything to do with boiler work, either new or repair work, who doesn't need this book. The manufacturer, superintendent, foreman, and boiler worker—all need it. No matter what the type of boiler, you'll find a mint of information that you wouldn't be without. 451 pages, 334 illustrations, five large folding plates. Price . . . . . \$3.50

### LOCOMOTIVE BREAKDOWNS AND THEIR REMEDIES. By GEO. L. FOWLER. Revised by WM. W. WOOD, Air-Brake Instructor. Just issued. Revised pocket edition.

It is out of the question to try and tell you about every subject that is covered in this pocket edition of Locomotive Breakdowns. Just imagine all the common troubles that an engineer may expect to happen some time, and then add all of the unexpected ones, troubles that could occur, but that you have never thought about, and you will find that they are all treated with the very best methods of repair. Walschaert Locomotive Valve Gear Troubles, Electric Headlight Troubles, as well as Questions and Answers on the Air Brake are all included. 293 pages. 8th Revised Edition. Fully illustrated. . . . . \$1.50

### PRACTICAL INSTRUCTOR AND REFERENCE BOOK FOR LOCOMOTIVE FIREMEN AND ENGINEERS. By CHAS. F. LOCKHART.

An entirely new book on the Locomotive. It appeals to every railroad man, as it tells him how things are done and the right way to do them. Written by a man who has had years of practical experience in locomotive shops and on the road firing and running. The information given in this book cannot be found in any other similar treatise. Eight hundred and fifty-one questions with their answers are included, which will prove specially helpful to those preparing for examination. Practical information on: The Construction and Operation of Locomotives; Breakdowns and their Remedies; Air Brakes and Valve Gears. Rules and Signals are handled in a thorough manner. As a book of reference it cannot be excelled. The book is divided into six parts, as follows: 1. The Fireman's Duties. 2. General Description of the Locomotive. 3. Breakdowns and their Remedies. 4. Air Brakes. 5. Extracts from Standard Rules. 6. Questions for Examination. The 851 questions have been carefully selected and arranged. These cover the examinations required by the different railroads. 368 pages. 88 illustrations. Price . . . . . \$2.50

### PREVENTION OF RAILROAD ACCIDENTS, OR SAFETY IN RAILROADING. By GEORGE BRADSHAW.

This book is a heart-to-heart talk with Railroad Employees, dealing with facts, not theories, and showing the men in the ranks, from every-day experience, how accidents occur and how they may be avoided. The book is illustrated with seventy original photographs and drawings showing the safe and unsafe methods of work. No visionary schemes, no ideal pictures. Just plain facts and Practical Suggestions are given. Every railroad employee who reads the book is a better and safer man to have in railroad service. It gives just the information which will be the means of preventing many injuries and deaths. All railroad employees should procure a copy; read it, and do your part in preventing accidents. 169 pages. Pocket size. Fully illustrated. Price . . . . . 50 cents

## CATALOGUE OF GOOD, PRACTICAL BOOKS

### **TRAIN RULE EXAMINATIONS MADE EASY.** By G. E. COLLINGWOOD.

This is the only practical work on train rules in print. Every detail is covered, and puzzling points are explained in simple, comprehensive language, making it a practical treatise for the Train Dispatcher, Engineman, Trainman, and all others who have to do with the movements of trains. Contains complete and reliable information of the Standard Code of Train Rules for single track. Shows Signals in Colors, as used on the different roads. Explains fully the practical application of train orders, giving a clear and definite understanding of all orders which may be used. The meaning and necessity for certain rules are explained in such a manner that the student may know beyond a doubt the rights conferred under any orders he may receive or the action required by certain rules. As nearly all roads require trainmen to pass regular examinations, a complete set of examination questions, with their answers, are included. These will enable the student to pass the required examinations with credit to himself and the road for which he works. Second Edition revised. 234 pages. Fully illustrated with Train Signals in Colors. Price . . . . . \$1.50

### **THE WALSCHAERT AND OTHER MODERN RADIAL VALVE GEARS FOR LOCOMOTIVES.** By Wm. W. Wood.

If you would thoroughly understand the Walschaert Valve Gear you should possess a copy of this book, as the author takes the plainest form of a steam engine—a stationary engine in the rough, that will only turn its crank in one direction—and from it builds up—with the reader's help—a modern locomotive equipped with the Walschaert Valve Gear, complete. The points discussed are clearly illustrated; two large folding plates that show the positions of the valves of both inside or outside admission type, as well as the links and other parts of the gear when the crank is at nine different points in its revolution, are especially valuable in making the movement clear. These employ sliding cardboard models which are contained in a pocket in the cover.

The book is divided into five general divisions, as follows: 1. Analysis of the gear. 2. Designing and erecting the gear. 3. Advantages of the gear. 4. Questions and answers relating to the Walschaert Valve Gear. 5. Setting valves with the Walschaert Valve Gear; the three primary types of locomotive valve motion; modern radial valve gears other than the Walschaert; the Hobart All-free Valve and Valve Gear, with questions and answers on breakdowns; the Baker-Pilliod Valve Gear; the Improved Baker-Pilliod Valve Gear, with questions and answers on breakdowns.

The questions with full answers given will be especially valuable to firemen and engineers in preparing for an examination for promotion. 245 pages. Fully illustrated. Third Revised New Edition. Price . . . . . \$2.50

### **WESTINGHOUSE E-T AIR-BRAKE INSTRUCTION POCKET BOOK.** By Wm. W. Wood, Air-Brake Instructor.

Here is a book for the railroad man, and the man who aims to be one. It is without doubt the only complete work published on the Westinghouse E-T Locomotive Brake Equipment. Written by an Air-Brake Instructor who knows just what is needed. It covers the subject thoroughly. Everything about the New Westinghouse Engine and Tender Brake Equipment, including the standard No. 5 and the Perfect'd No. 6 style of brake, is treated in detail. Written in plain English and profusely illustrated with Colored Plates, which enable one to trace the flow of pressures throughout the entire equipment. The best book ever published on the Air Brake. Equally good for the beginner and the advanced engineer. Will pass anyone through any examination. It informs and enlightens you on every point. Indispensable to every engineman and trainman.

Contains examination questions and answers on the E-T equipment. Covering what the E-T Brake is. How it should be operated. What to do when defective. Not a question can be asked of the engineman up for promotion, on either the No. 5 or the No. 6 E-T equipment, that is not asked and answered in the book. If you want to thoroughly understand the E-T equipment get a copy of this book. It covers every detail. Makes Air-Brake troubles and examinations easy. Second Revised and Enlarged Edition. Price . . . . . \$2.50

# CATALOGUE OF GOOD, PRACTICAL BOOKS

## MACHINE-SHOP PRACTICE

### AMERICAN TOOL MAKING AND INTERCHANGEABLE MANUFACTURING. By J. V. WOODWORTH.

A "shopy" book, containing no theorizing, no problematical or experimental devices, there are no badly proportioned and impossible diagrams, no catalogue cuts, but a valuable collection of drawings and descriptions of devices, the rich fruits of the author's own experience. In its 500-odd pages the one subject only, Tool Making, and whatever relates thereto, is dealt with. The work stands without a rival. It is a complete practical treatise on the art of American Tool Making and system of interchangeable manufacturing as carried on to-day in the United States. In it are described and illustrated all of the different types and classes of small tools, fixtures, devices, and special appliances which are in general use in all machine-manufacturing and mechanical working establishments where economy, capacity, and interchangeability in the production of machined metal parts are imperative. The science of jig making is exhaustively discussed, and particular attention is paid to drill jigs, boring, profiling and mill fixtures and other devices in which the parts to be machined are located and fastened within the contrivances. All of the tools, fixtures, and devices illustrated and described have been or are used for the actual production of work, such as parts of presses, lathes, patented machinery, typewriters, electrical apparatus, mechanical appliances, brass goods, composition parts, mould products, sheet metal articles, drill forgings, jewelry, watches, medals, coins, etc. 3rd Edition. 531 pages. Price \$4.

### MACHINE-SHOP ARITHMETIC. By COLVIN-CHENEY.

This is an arithmetic of the things you have to do with daily. It tells you plain about: how to find areas in figures; how to find surface or volume of balls or spheres; handy ways for calculating; about compound gearing; cutting screw threads on a lathe; drilling for taps; speeds of drills; taps, emery wheels, grindstones, mill cutters, etc.; all about the Metric system with conversion tables; properties of metals; strength of bolts and nuts; decimal equivalent of an inch. All sorts of machine-shop figuring and 1,001 other things, any one of which ought to be worth more than the price of this book to you, and it saves you the trouble of bothering the boss. 1st edition. 131 pages. Price . . . . . 75 cents

### MODERN MACHINE-SHOP CONSTRUCTION, EQUIPMENT AND MANAGEMENT. By OSCAR E. PERRIGO.

The only work published that describes the Modern Shop or Manufacturing Plant from the time the grass is growing on the site intended for it until the finished product is shipped. Just the book needed by those contemplating the erection of modern shop buildings, the rebuilding and reorganization of old ones, or the introduction of Modern Shop Methods, time and cost systems. It is a book written and illustrated by a practical shop man for practical shop men who are too busy to read theories and want facts. It is the most complete all-round book of its kind ever published. 384 pages. 219 original and specially-made illustrations. Revised and Enlarged Edition. Price . . . . . \$5.

### "SHOP KINKS." By ROBERT GRIMSHAW.

A book of 400 pages and 222 illustrations, being entirely different from any other book on machine-shop practice. Departing from conventional style, the author avoids universal or common shop usage and limits his work to showing special ways of doing things better, more cheaply and more rapidly than usual. As a result, advanced methods of representative establishments of the world are placed at the disposal of the reader. This book shows the proprietor where large savings are possible and how products may be improved. To the employee it holds out suggestions that properly applied, will hasten his advancement. No shop can afford to be without it. It bristles with valuable wrinkles and helpful suggestions. It will benefit all, from apprentice to proprietor. 5th edition. Price . . . . . \$3.

### THREADS AND THREAD-CUTTING. By COLVIN and STABEL.

This clears up many of the mysteries of thread-cutting, such as double and triple threads, internal threads, catching threads, use of hobs, etc. Contains a lot of useful hints and several tables. 4th edition. Price . . . . . 35 cents

## CATALOGUE OF GOOD, PRACTICAL BOOKS

---

---

### THE WHOLE FIELD OF MECHANICAL MOVEMENTS COVERED BY MR. HISCOX'S TWO BOOKS

---

---

*We publish two books by Gardner D. Hiscox that will keep you from "inventing" things that have been done before, and suggest ways of doing things that you have not thought of before. Many a man spends time and money, pondering over some mechanical problem, only to learn, after he has solved the problem, that the same thing has been accomplished and put in practice by others long before. Time and money spent in an effort to accomplish what has already been accomplished are time and money LOST. The whole field of mechanics, every known mechanical movement, and practically every device is covered by these two books. If the thing you want has been invented, it is illustrated in them. If it hasn't been invented, then you'll find in them the nearest things to what you want, some movements or devices that will apply in your case, perhaps; or which will give you a key from which to work. No book or set of books ever published is of more real value to the Inventor, Draftsman, or practical Mechanic than the two volumes described below.*

#### **MECHANICAL MOVEMENTS, POWERS, AND DEVICES.** By GARDNER D. HISCOX.

This is a collection of 1,890 engravings of different mechanical motions and appliances, accompanied by appropriate text, making it a book of great value to the inventor, the draftsman, and to all readers with mechanical tastes. The book is divided into eighteen sections or chapters, in which the subject-matter is classified under the following heads: Mechanical Powers; Transmission of Power; Measurement of Power; Steam Power; Air Power Appliances; Electric Power and Construction; Navigation and Roads; Gearing; Motion and Devices; Controlling Motion; Horological; Mining; Mill and Factory Appliances; Construction and Devices; Drafting Devices; Miscellaneous Devices, etc. 15th edition enlarged. 400 octavo pages. Price . \$4.00

#### **MECHANICAL APPLIANCES, MECHANICAL MOVEMENTS AND NOVELTIES OF CONSTRUCTION.** By GARDNER D. HISCOX.

This is a supplementary volume to the one upon mechanical movements. Unlike the first volume, which is more elementary in character, this volume contains illustrations and descriptions of many combinations of motions and of mechanical devices and appliances found in different lines of machinery, each device being shown by a line drawing with a description showing its working parts and the method of operation. From the multitude of devices described and illustrated might be mentioned, in passing, such items as conveyors and elevators, Prony brakes, thermometers, various types of boilers, solar engines, oil-fuel burners, condensers, evaporators, Corliss and other valve gears, governors, gas engines, water motors of various descriptions, airships, motors and dynamos, automobile and motor bicycles, railway lock signals, car couplers, link and gear motions, ball bearings, breech block mechanism for heavy guns, and a large accumulation of others of equal importance. 1,000 specially made engravings. 396 octavo pages. 4th Edition enlarged. Price . . . . . \$4.00

#### **SHOP PRACTICE FOR HOME MECHANICS.** By RAYMOND FRANCIS YATES.

A thoroughly practical and helpful treatment prepared especially for those who have had little or no experience in shop work. The introduction is given over to an elementary explanation of the fundamentals of mechanical science. This is followed by several chapters on the use of small tools and mechanical measuring instruments. Elementary and more advanced lathe work is treated in detail and directions given for the construction of a number of useful shop appliances. Drilling and reaming, heat treatment of tool steel, special lathe operations, pattern making, grinding, and grinding operations, home foundry work, etc., make up the rest of the volume. The book omits nothing that will be of use to those who use tools or to those who wish to learn the use of tools. The great number of clear engravings (over 300) add tremendously to the text matter and to the value of the volume as a visual instructor. Octavo, 320 pages. 309 engravings. Price . . . . . \$3.00

## CATALOGUE OF GOOD, PRACTICAL BOOKS

---

---

### **MACHINE-SHOP TOOLS AND SHOP PRACTICE.** By W. H. VANDERVOOIJ

A work of 552 pages and 672 illustrations, describing in every detail the constructive operation, and manipulation of both hand and machine tools. Includes chapters on filing, fitting, and scraping surfaces; on drills, reamers, taps, and dies; the lathe and its tools; planers, shapers, and their tools; milling machines and cutters; gear cutters and gear cutting; drilling machines and drill work; grinding machines and their work; hardening and tempering; gearing, belting, and transmission machines; useful data and tables. 7th Edition. 552 pages. 672 illustrations. Price **\$4.**

### **COMPLETE PRACTICAL MACHINIST.** By JOSHUA ROSE.

The new, twentieth revised and enlarged edition is now ready. This is one of the best-known books on machine-shop work, and written for the practical workman in the language of the workshop. It gives full, practical instructions on the use of all kinds of metal-working tools, both hand and machine, and tells how the work should be properly done. It covers lathe work, vise work, drills and drilling, taps and dies, hardening and tempering, the making and use of tools, tool grinding, mapping out work, machine tools, etc. No machinist's library is complete without this volume. 20th Edition. 547 pages. 432 illustrations. Price . . . . . **\$3.**

### **HENLEY'S ENCYCLOPEDIA OF PRACTICAL ENGINEERING AND ALLIED TRADES.** Edited by JOSEPH G. HORNER, A.M.I.Mech.E.

This book covers the entire practice of Civil and Mechanical Engineering. The best known experts in all branches of engineering have contributed to these volumes. The Encyclopedia is admirably well adapted to the needs of the beginner and the self-taught practical man, as well as the mechanical engineer, designer, draftsman, and superintendent, foreman and machinist.

It is a modern treatise in five volumes. Handsomely bound in half morocco, each volume containing nearly 500 pages, with thousands of illustrations, including diagrams, grammatic and sectional drawings with full explanatory details. Five large volumes. Price . . . . . **\$80.**

### **MODEL MAKING Including Workshop Practice, Design and Construction Models.** Edited by RAYMOND F. YATES. Editor of "Everyday Engineering Magazine."

This book will help you to become a better mechanic. It is full of suggestions for those who like to make things, amateur and professional alike. It has been prepared especially for men with mechanical hobbies. Some may be engineers, machinists, journeymen, clerks, pattern makers, office clerks or bank presidents. Men from various walks of life have a peculiar interest in model engineering. MODEL MAKING will be a help and an inspiration to such men. It tells them "how-to-do" and "how-to-make" their models in simple, understandable terms. Not only this, it is full of good, clear work drawings and photographs of the models and apparatus described. Each model has been constructed and actually works if it is made according to directions. 379 pages. 300 illustrations. Price . . . . . **\$3.**

### **ABRASIVES AND ABRASIVE WHEELS.** By FRED B. JACOBS.

A new book for everyone interested in abrasives or grinding. A careful reading of the book will not only make mechanics better able to use abrasives intelligently, but it will also tell the shop superintendent of many short cuts and efficiency-increasing kinks. The economic advantages in using large grinding wheels are fully explained together with many other things that will tend to give the superintendent or workman a keen insight into abrasive engineering. 340 pages. 174 illustrations. This is an indispensable book for every machinist. Price . . . . . **\$3.**

### **HOME MECHANIC'S WORKSHOP COMPANION.** By ANDREW JACKSON, J

This treatise includes a compilation of useful suggestions that cannot fail to interest the handy man, and while it is not intended for mechanical experts or scientists, it will prove to be a veritable store of information for anyone who desires to rig up a small shop where odd jobs can be carried on. Price . . . . . **75 cts**

---

---

## CATALOGUE OF GOOD, PRACTICAL BOOKS

---

---

### MARINE ENGINEERING

**THE NAVAL ARCHITECT'S AND SHIPBUILDER'S POCKETBOOK.** Of Formulæ, Rules, and Tables and Marine Engineer's and Surveyor's Handy Book of Reference. By CLEMENT MACKROW and LLOYD WOOLLARD.

The twelfth revised and enlarged edition of this most comprehensive work has just been issued. It is absolutely indispensable to all engaged in the Shipbuilding Industry, as it condenses into a compact form all data and formulæ that are ordinarily required. The book is completely up to date, including among other subjects a section on Aeronautics. 760 pages, limp leather binding. Price . . . . . \$6.00

**MARINE ENGINES AND BOILERS—THEIR DESIGN AND CONSTRUCTION. THE STANDARD BOOK.** By DR. G. BAUER, LESLIE S. ROBERTSON and S. BRYAN DONKIN.

In the words of Dr. Bauer, the present work owes its origin to an oft felt want of a condensed treatise embodying the theoretical and practical rules used in designing marine engines and boilers. The fact that the original German work was written by the chief engineer of the famous Vulcan Works, Stettin, is in itself a guarantee that this book is in all respects thoroughly up-to-date, and that it embodies all the information which is necessary for the design and construction of the highest types of marine engines and boilers. It may be said that the motive power which Dr. Bauer has placed in the fast German liners that have been turned out of late years from the Stettin Works represent the very best practice in marine engineering of the present day. The work is clearly written, thoroughly systematic, theoretically sound; while the character of the plans, drawings, tables, and statistics is without reproach. The illustrations are careful reproductions from actual working drawings, with some well-executed photographic views of completed engines and boilers. Fifth impression. 744 pages. 550 illustrations, and numerous tables. Cloth. Price . . . \$10.00

### MANUAL TRAINING

**ECONOMICS OF MANUAL TRAINING.** By LOUIS ROULLION.

The only book published that gives just the information needed by all interested in Manual Training, regarding Buildings, Equipment, and Supplies. Shows exactly what is needed for all grades of the work from the Kindergarten to the High and Normal School. Gives itemized lists of everything used in Manual Training Work and tells just what it ought to cost. Also shows where to buy supplies, etc. Contains 174 pages, and is fully illustrated. 2d edition. Price . . . . . \$2.00

### MOTOR BOATS

**MOTOR BOATS AND BOAT MOTORS.** By VICTOR W. PAGÉ and A. C. LEITCH.

All who are interested in motor boats, either as owners, builders or repairmen, will find this latest work a most comprehensive treatise on the design, construction, operation and repair of motor boats and their power plants. It is really two complete books in one cover as it consists of two parts, each complete in itself. Part One deals with THE HULL AND ITS FITTINGS, Part Two considers THE POWER PLANT AND ITS AUXILIARIES. A valuable feature of this book is the complete set of dimensioned working drawings detailing the construction of five different types of boats ranging from a 16-foot shallow draft, tunnel stern general utility craft to a 25-foot cabin cruiser. These plans are by A. C. Leitch, a practical boat builder and expert naval architect, and are complete in every particular. Full instructions are given for the selection of a power plant and its installation in the hull. Valuable advice is included on boat and engine operation and latest designs of motors are described and illustrated. The instructions for overhauling boat and engine are worth many times the small cost of the book. It is a comprehensive work of reference for all interested in motor boating in any of its phases. Octavo. Cloth. 372 illustrations. 524 pages. Price . . . . . \$4.00

