



LIBRARY
OF THE
UNIVERSITY
OF ILLINOIS

630.7

I16b

nos. 638-654

cop. 2

AGRICULTURE

NON CIRCULATING

CHECK FOR UNBOUND
CIRCULATING COPY

DESIGN OF NAILED AND GLUED PLYWOOD GUSSETS FOR LUMBER RIGID FRAMES

By J. O. CURTIS



Load Tests on Rigid Joints	5
Materials Used	5
Details of Joints Tested	5
Test Procedure and Equipment	9
Development of Joint Design Procedure	11
Tentative Design Procedure	11
Verification of Tentative Design Procedure	14
Final Design Procedure	16
Other Test Results and Observations	16
Effect of Orientation of Grain of the Plywood	16
Effect of Direction of Load on Joint Strength	17
Buckling of the Edge of the Plywood Gussets	18
References	18
Appendix	19
Summary	20

Frank W. Bauling, deceased, formerly Graduate Assistant in Agricultural Engineering, did some of the initial work on the project reported here. The Douglas Fir Plywood Association, Tacoma, Washington, provided the plywood used.

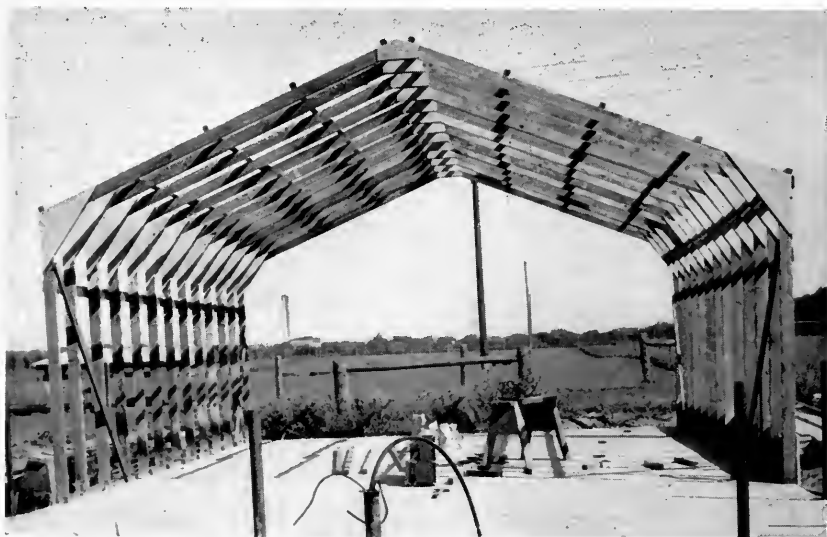

This framework of a small experimental swine shelter shows the type of rigid-frame design being developed. (Fig. 1)

Design of Nailed and Glued Plywood Gussets for Lumber Rigid Frames

By J. O. CURTIS, Assistant Professor of Agricultural Engineering

IN RECENT YEARS rigid frames have been used in increasing numbers in the construction of farm buildings. Most of the major fabricators of steel farm buildings have developed rigid-frame designs. The glued, laminated, wooden arch, which has been widely used in farm building construction, may be classified as a three-hinged rigid frame. In 1955 the Plywood Manufacturers Association of British Columbia prepared a series of designs, "Rigid Frames for Fir Plywood Structures." (1)^a

There are several reasons for the increased use of this system of framing. Since no interior supports, braces, or ties of any type are required, the entire space within the building is free from obstructions and usable. The system of framing is simple, requiring a comparatively small number of different sizes and shapes of structural members. It compares favorably from an economic standpoint with other systems of clear-span construction, such as trusses.

In the summer of 1957, the Department of Agricultural Engineering at the University of Illinois decided to undertake the development of additional rigid-frame designs. The work started with gable-shaped designs consisting of dimension lumber for framing members, a vertical stud, and nailed and glued plywood gusset plates. The frame was planned for construction mainly by home or local labor and from stock lumber materials, whereas the steel rigid frames and glued laminated lumber frames have been developed primarily for factory fabrication. The design differs from those of the Plywood Manufacturers Association of British Columbia in three ways: First, it has a vertical instead of an inclined stud member. Second, the gusset plate is both nailed and glued instead of being nailed only. And finally, the gusset extends inward from the outer edge of the stud rather than outward from the inner edge, as in the Canadian design.

To evaluate this system of framing in a preliminary way, a small swine shelter 18 feet wide and 24 feet long was designed and built on the University farm in the fall of 1957. The framework of this structure is shown in Fig. 1.

In designing the framing for the swine shelter, accepted procedures

^a Numbers in parentheses refer to references on page 18.

of structural analysis were used to determine stresses in members. No established procedure could be found, however, for designing the nailed and glued plywood gussets, which were subjected primarily to a bending load. Work done by Radcliffe (2) at Purdue in designing nail-glued plywood gusset plates was helpful, but it involved a somewhat different type of problem. His procedure was primarily for use in designing gusset plates connecting truss members, where the members being connected are subjected primarily to axial loads, whereas the gusset plates used in constructing rigid frames connect members that are subjected to large bending moments.

In December, 1958, Petry (3) of the Douglas Fir Plywood Association suggested a procedure for designing nailed plywood gusset plates for rigid frames. There was still, however, no established procedure for designing nailed and glued plywood gusset plates that are subjected primarily to bending loads as they would be when forming the joints of a rigid frame.

This bulletin reports the development of a procedure for the design of nailed and glued plywood gussets for lumber rigid frames. Load tests were made on a series of full-scale joints formed with nailed and glued plywood gussets. The results of these tests were used as a basis for establishing the joint design procedure.

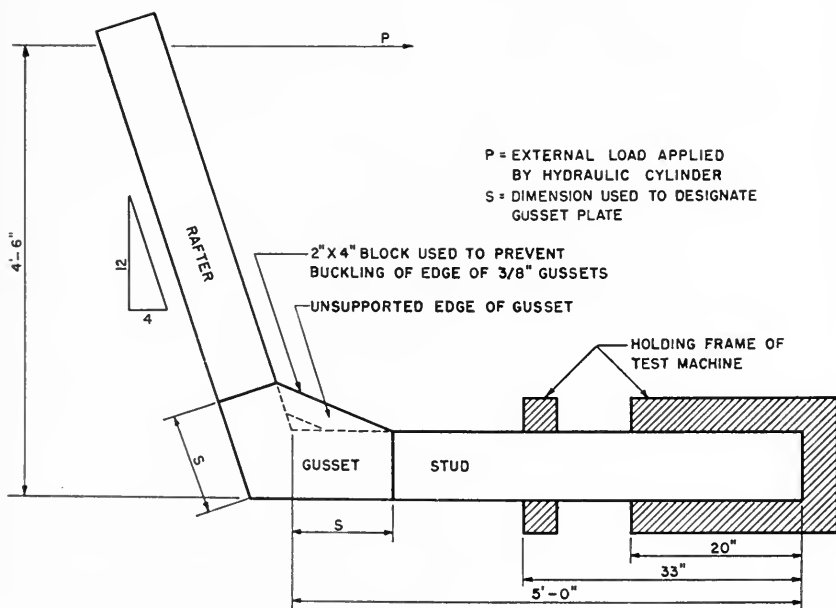

Layout of the joints tested and the system of loading.

(Fig. 2)

Load Tests on Rigid Joints

Load tests were performed on 88 rigid joints formed with plywood gusset plates nailed and glued to the framing members. The general layout of the joints and how they were loaded are shown in Fig. 2.

Materials Used

Construction-grade Douglas fir lumber was used. Moisture content of the lumber was measured with a Delmhorst moisture detector at the time the joints were load-tested. It averaged about 14.5 percent.

Douglas fir plywood used for the gussets was C-C exterior-sheathing grade. Two thicknesses of plywood were used: $\frac{3}{8}$ inch and $\frac{5}{8}$ inch. Random measurements indicated that the actual thickness of the plywood averaged about $\frac{1}{32}$ inch less than the nominal thickness, so the actual thickness of the $\frac{3}{8}$ -inch plywood was 0.344 inch and the $\frac{5}{8}$ -inch plywood 0.594 inch. The five plies of the $\frac{5}{8}$ -inch plywood were approximately the same thickness. The center ply of the $\frac{3}{8}$ -inch plywood was thicker than the two face plies, random measurements indicating that the center ply was approximately 0.151 inch thick and each face ply approximately 0.0965 inch thick.

The glue used was Type II casein, which is mold- and water-resistant. It was mixed at the rate of one pound of glue to two pounds of water, in accordance with manufacturer's instructions.

Details of Joints Tested

In addition to some preliminary tests, 22 different types of joints were fabricated and tested (Fig. 3). The variables included in the various joints were size of framing lumber, thickness of plywood in gusset, size of gusset, and orientation of grain of the face plies of the gusset. Sizes of framing lumber were 2 x 4, 2 x 6, 2 x 8, 2 x 10, and 2 x 12 inches. Two gusset plate thicknesses were included: $\frac{3}{8}$ inch and $\frac{5}{8}$ inch. Sizes of the gusset plates, designated in inches according to the detail shown in Fig. 2, were 6, 9, 12, 18, and 24. Orientation of the grain of the face plies of the gusset was designated in degrees with respect to direction of grain in the stud member. Orientations included in the tests were 0, 22.5, 45, 67.5, and 90 degrees.

Each joint was described in accordance with the following example: 2 x 8 - $\frac{3}{8}$ - 12 - 45. The designation "2 x 8" indicated size of framing lumber; " $\frac{3}{8}$ " designated plywood thickness; "12" designated gusset plate size; and "45" designated orientation of the grain of the face plies of the gusset.

The joints were all detailed as shown in Fig. 2. They were built



Twenty-two different types of joints were tested. Twenty-one are shown here. (Fig. 3)

in the laboratory, where temperatures were 70° F. or warmer. Glue was applied with a brush to one surface of the members being joined. It was then struck off with a notched scraper to make the rate of application reasonably uniform. A scraper was selected that would apply just enough glue to cause a small amount to squeeze out when the joint was assembled. Rate of spread was calculated to be about 10 square feet of glue area per pound of mixed glue. Nails were used to apply pressure while the glue set. Recommendations of Radcliffe (2) were used as a basis for nail size and spacing; 4d common nails were used with $\frac{3}{8}$ -inch gussets and 6d common nails with $\frac{5}{8}$ -inch gussets. Nails were placed roughly $\frac{3}{4}$ inch from the edge of the members and gussets and 3 inches apart in each direction (Fig. 4). The average glue area per nail was 7.8 square inches, and the maximum was 10.4 square inches.

The preliminary tests indicated that the unsupported edges of the $\frac{3}{8}$ -inch gussets required support in order to prevent them from buckling (Fig. 5), so a 2 x 4 block was nailed between the unsupported edges. No support was provided for the edges of the $\frac{5}{8}$ -inch gussets since the preliminary tests indicated that none was required.

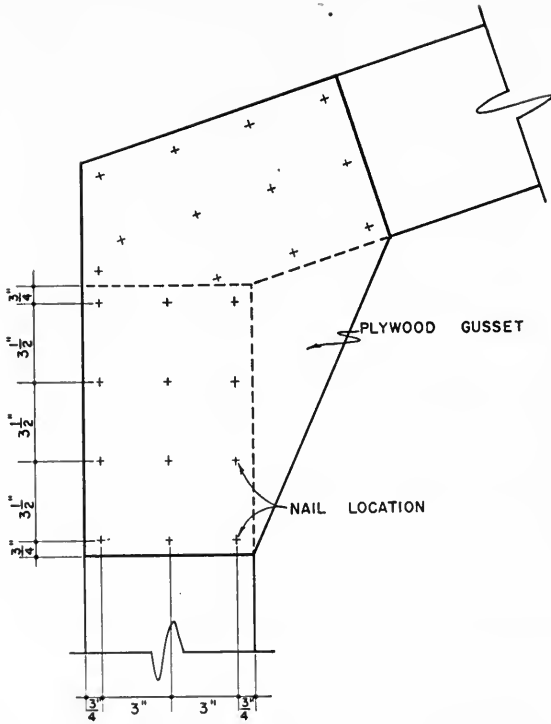

Typical joint showing approximate arrangement of the nails used in fabricating it. (Fig. 4)



The compression edge of 3/8-inch gussets must be supported to prevent buckling failures of the type shown. (Fig. 5)

Table 1.—Joints Tested to Serve as Basis for Establishing Basic Joint Design Procedure

(Loaded to produce compression in unsupported edge of gusset)

Joint No.	Description of joint (3 replications)	Load "P" at failure, pounds (mean value)	Method of failure ^a	Maximum "f" in		Shear "s" in glue line, p.s.i. (mean value)	Rating (S=Satisfactory; U=Unsatisfactory)				Composite rating of joint
				stud, p.s.i. ^b (mean value)	Gusset, p.s.i. (mean value)		"f" in stud greater than 5,180 p.s.i.	"f" in gusset less than "f" in stud	"s" in gusset less than 317 p.s.i.	"s" in gusset less than 317 p.s.i.	
1	2 x 4 — 3/8-6-0	325	A	4,812	7,162	340	U	U	U	U	U
2	2 x 4 — 3/8-9-0	430	B	6,373	5,579	216	U	S	S	S	S
3	2 x 4 — 3/8-12-0	417	A	6,175	3,066	123	S	S	S	S	S
4	2 x 4 — 3/8-6-0	375	C	5,550	4,466	390	S	S	U	S	U
5	2 x 6 — 3/8-12-0	967	A	5,847	6,598	171	S	S	U	S	U
6	2 x 6 — 3/8-18-0	1,150	A	6,993	4,402	96	S	S	S	S	S
7	2 x 6 — 5/8-12-0	1,300	A	7,903	4,786	229	S	S	S	S	S
8	2 x 8 — 3/8-12-0	1,233	B	4,171	6,543	151	U	U	S	S	U
9	2 x 8 — 3/8-18-0	2,307	A	7,799	7,397	137	S	S	S	S	S
10	2 x 8 — 5/8-12-0	2,000	A	6,760	6,796	245	S	U	U	S	U
11	2 x 10 — 3/8-12-0	2,250	B	4,677	9,882	196	U	U	U	S	U
12	2 x 10 — 3/8-18-0	2,333	A	4,853	6,257	103	U	U	U	S	U
13	2 x 10 — 3/8-24-0	2,800	A	5,823	5,144	74	S	S	S	S	S
14	2 x 10 — 5/8-12-0	2,550	A	5,297	6,045	222	S	U	S	S	U
15	2 x 10 — 5/8-18-0	2,717	A	5,650	3,933	118	S	S	S	S	S
16	2 x 12 — 3/8-18-0	3,217	B	4,503	7,314	109	S	U	U	S	U
17	2 x 12 — 3/8-24-0	3,483	B	4,877	6,084	72	U	U	U	U	U
18	2 x 12 — 5/8-18-0	4,517	A	6,323	5,557	154	S	S	S	S	S

^a Coded as follows for each replication: A—stud or rafter failed in bending; B—gusset failed in bending; C—gusset failed in rolling shear.^b p.s.i. = pounds per square inch.

Table 2.— Joints Tested to Evaluate Effect of Orientation of Grain of Plywood
(Loaded to produce compression in unsupported edge of gusset)

Description of joint (5 replications)	Load "P" at failure, pounds (mean value)	Method of failure ^a	Maximum "f" in stud, p.s.i. (mean value)
2 x 8 — $\frac{3}{8}$ -12-0	1,315	B B B B B	4,444
2 x 8 — $\frac{3}{8}$ -12-22.5	1,511	B B A B B	5,109
2 x 8 — $\frac{3}{8}$ -12-45	1,130	B B B B B	3,822
2 x 8 — $\frac{3}{8}$ -12-67.5	1,065	B B B B B	3,600
2 x 8 — $\frac{3}{8}$ -12-90	1,220	B B B B B	4,125

^a A — stud or rafter failed in bending; B — gusset failed in bending.

Test Procedure and Equipment

The 88 joints tested were grouped in three test series. Fifty-four joints consisting of three replications of each of the 18 joints described in Table 1 were tested to serve as a basis for establishing the basic joint design procedure. These joints were loaded as shown in Fig. 2 to produce compression in the unsupported edge of the gusset. Twenty-five joints (3 of these are also included in Table 1) consisting of five replications of each of the five joints listed in Table 2 were tested to evaluate the effect of orientation of grain of the plywood gussets. Twelve joints consisting of one of each of those listed in Table 3 were

Table 3.— Joints Tested to Produce Tension in Unsupported Edge of Gusset

Description of joint	Load "P" at failure, pounds	Method of failure ^a	Maximum "f" in stud, p.s.i.
Part A — Joints having "0" degree angle of grain of face plies of gusset			
2 x 4 — $\frac{3}{8}$ -12-0	742	A	11,000
2 x 6 — $\frac{3}{8}$ -12-0	1,350	A	8,080
2 x 8 — $\frac{3}{8}$ -18-0	742	A	2,510
2 x 8 — $\frac{5}{8}$ -12-0	1,733	A	5,860
2 x 10 — $\frac{3}{8}$ -24-0	2,687	A	5,590
2 x 10 — $\frac{5}{8}$ -18-0	2,900	A	6,030
2 x 12 — $\frac{5}{8}$ -18-0	3,820	A	5,340
Part B — Joints having various angles of grain of face plies of gusset			
2 x 8 — $\frac{3}{8}$ -12-0	1,733	B	5,870
2 x 8 — $\frac{3}{8}$ -12-22.5	1,520	B	5,140
2 x 8 — $\frac{3}{8}$ -12-45	1,485	B	5,020
2 x 8 — $\frac{3}{8}$ -12-67.5	1,803	B	6,100
2 x 8 — $\frac{3}{8}$ -12-90	1,627	B	5,500

^a A — stud or rafter failed in bending; B — gusset failed in bending.

tested to evaluate the effect of a direction of load that produces tension rather than compression in the unsupported edge of the gusset.

All joints were load-tested one week after fabrication. The system of loading and the test machine that was used are shown in schematic form in Fig. 2 and in photographic form in Fig. 6. The lower end of the stud member was held by the machine, and a load was applied to the rafter member by using a hydraulic cylinder. In the test shown in Fig. 6, the cylinder was exerting a pull on the rafter member and thus producing compression in the unsupported edge of the gusset. The machine was modified so that it exerted a push on the rafter for the tests where tension was desired in the unsupported edge of the gusset.

Data were recorded on the load applied by the cylinder at failure (Load "P") and the method of failure of the joint. Load at failure was measured with a strain gage dynamometer that was inserted to measure the force exerted by the hydraulic cylinder. As a check it was also calculated from pressure readings from the hydraulic loading system. Pressure readings alone were used for the tests where the cylinder exerted a push on the rafter.

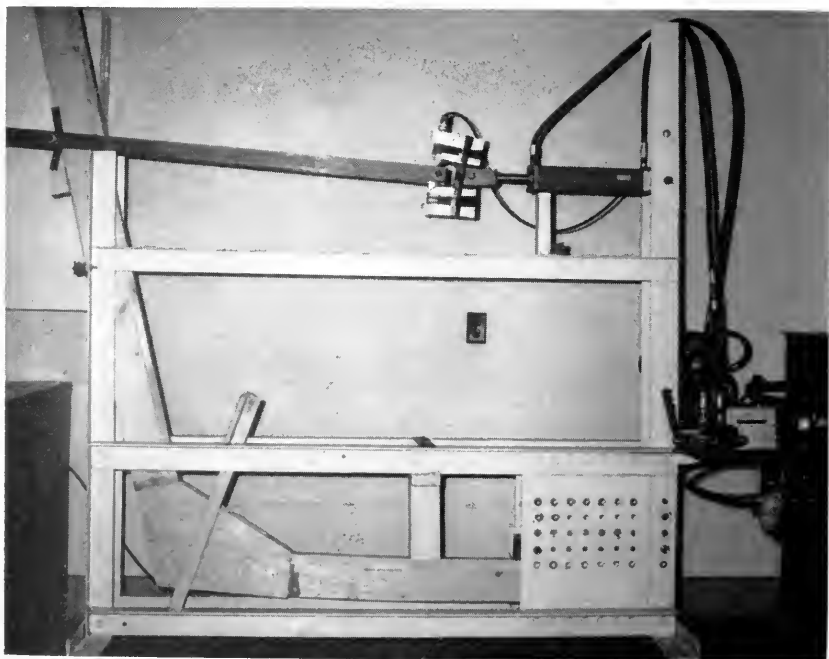

Test equipment used in making the load tests on the joints.

(Fig. 6)

Development of Joint Design Procedure

The goal was to develop a joint design procedure that would make it possible to determine analytically the details of the joint required. In developing the design procedure, a tentative design procedure was formulated first, and then the procedure was verified by trying it on the joints tested.

Tentative Design Procedure

The tentative design procedure was formulated on the basis of general knowledge of the behavior of structural members under load and on the basis of observations of the behavior of the joints tested. Test results are recorded in Tables 1, 2, and 3. The joints tested were observed to fail in one of the following three ways:

1. Stud or rafter failed in extreme fiber owing to combined bending and axial load (Fig. 7).
2. Gusset failed in extreme fiber along a line approximately through the junction of the stud and rafter (Fig. 8).
3. Gusset failed in rolling shear in a plane parallel to the plane of the glue line (Fig. 9).

It seemed reasonable therefore that the design of the joint should involve checking the three types of stresses corresponding to the ob-

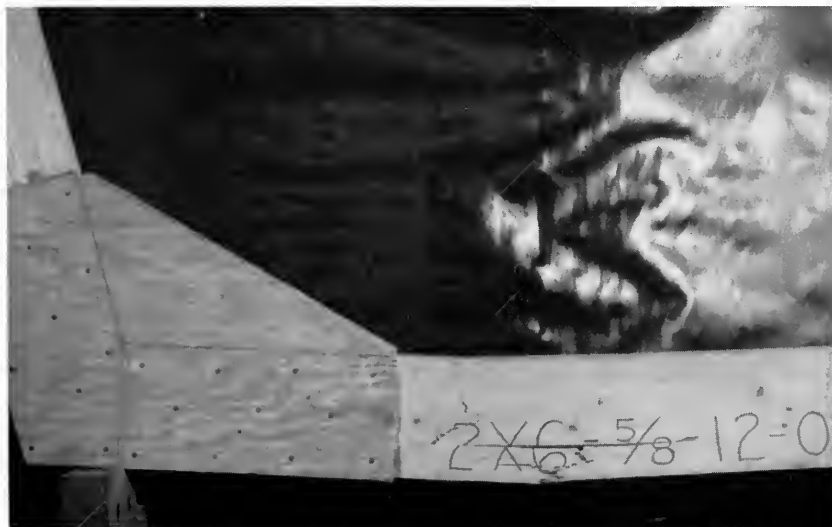

Typical extreme fiber failure in the stud member due to combined bending and axial load. (Fig. 7)

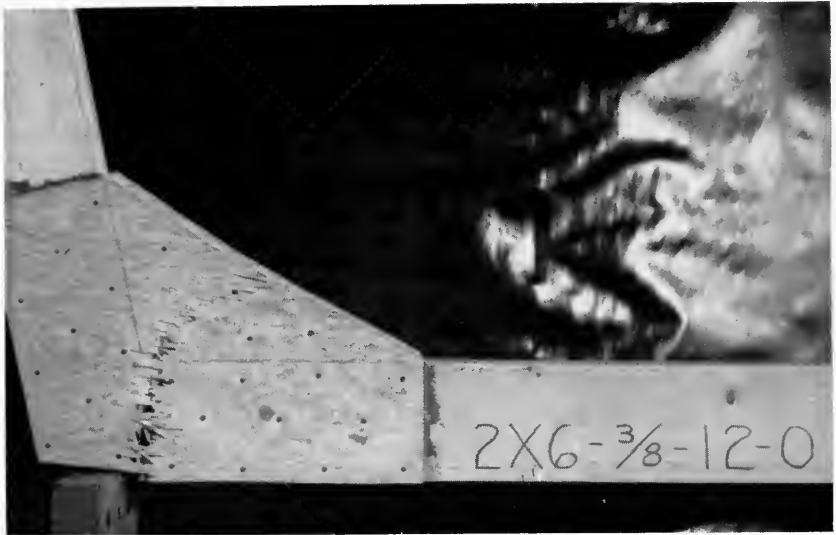

Typical extreme fiber failure in the gusset due to combined bending and axial load. (Fig. 8)

served methods of failure. Also it seemed reasonable that the basic criterion of a satisfactory joint should be a joint strong enough to develop the full strength of the framing members being joined. On this basis then a satisfactory joint should:

1. Develop the maximum fiber stress expected at failure in the members being joined.
2. Have plywood gussets of such size and thickness that the stress in extreme fiber in the gussets would not be excessive.
3. Have plywood gussets of such size that shear stress parallel to the glue line would not be excessive.

Before attempting to apply the above proposal to the design of joints, it was necessary to establish acceptable values for the three types of stresses involved. Ultimate stress values were selected rather than working stress values since the plan was to verify the procedure by checking it on the joints that were load-tested. Since only the load at failure was recorded in the tests, only ultimate stress values could be calculated for the joints tested.

The maximum fiber stress expected at failure in the members being joined was calculated on the basis of data from the Wood Handbook (4) and other sources. The modulus of rupture for Douglas fir, coast type, was multiplied by the strength ratio for construction-grade Douglas fir. The value used for modulus of rupture was 7,600 pounds per



Typical shear failure in gusset in plane parallel to the glue bond. (Fig. 9)

square inch (p.s.i.). The appropriate strength ratio was determined from the grading rules to be 57 percent. Multiplying 7,600 by 57 percent gives 4,330 p.s.i. as the fiber stress expected at failure in the framing members for the grade of lumber used, if in the green condition. Since the lumber used was not green but had an average moisture content of 14.5 percent, the fiber stress expected at failure would be somewhat higher than 4,330 p.s.i. because lumber becomes stronger as it dries. On the basis of work reported by Snodgrass (5) of the Oregon Forest Products Research Center, an increase in strength due to drying of about 20 percent appeared reasonable for the grade and moisture content of the lumber used. Thus a value of 5,180 p.s.i. was established as the fiber stress expected at failure in the framing members.

The maximum acceptable value for ultimate stress in extreme fiber in the gussets was established by comparing the recommended working stresses in plywood and in construction-grade Douglas fir. Since the allowable working stress in extreme fiber is 1,875 p.s.i. for the grade of plywood used compared with 1,500 p.s.i. for construction-grade Douglas fir framing members, it seemed safe to use an ultimate extreme fiber stress in bending for the plywood equal to that assumed for the framing members. A value of 5,180 p.s.i. was therefore established as the maximum acceptable value for ultimate stress in extreme fiber in the gussets.

The maximum acceptable value for ultimate stress in shear parallel to the glue line was established as 317 p.s.i. This value was selected on the basis of work done by Radcliffe (2).

The tentative design procedure then may be summarized as follows:

1. The joint must be strong enough to develop in the members being joined an extreme fiber stress of 5,180 p.s.i.
2. The calculated maximum extreme fiber stress in the gussets must be not over 5,180 p.s.i.
3. The calculated maximum shear stress parallel to the glue line in the gussets must not be over 317 p.s.i.

Verification of Tentative Design Procedure

The tentative design procedure was checked by trying it on the joints that were load-tested. This was done to attempt to determine whether the proposed analytical design procedure could be used to accurately predict the behavior of the joints. In order to try the design procedure on the joints, it was necessary to calculate the maximum extreme fiber stress in the stud, the maximum extreme fiber stress in the gusset, and the maximum shear stress in the gusset in a plane parallel to the glue bond.

The maximum extreme fiber stress in the stud is simply the result of the combined bending and axial stresses produced by the system of loading. The maximum extreme fiber stress in the stud was calculated for each joint tested, and it is recorded in Tables 1, 2, and 3 as "Maximum 'f' in stud." (See Appendix and Fig. 10 for an example of calculation.)

In order to calculate the maximum fiber stress in the gusset, it was necessary to make three assumptions. First, only plies with direction of grain approximately parallel to direction of maximum fiber stress were considered effective. Second, the effective depth of the gusset was considered to be the distance $a + b$ along the assumed line of failure as indicated in Fig. 10. This assumption was based on observations of joint failures. Finally, it was assumed that the block used to prevent buckling of the unsupported edge of the $\frac{3}{8}$ -inch gussets carried no stress. The maximum fiber stress in the gusset was calculated for each of the joints listed in Table 1 and recorded in Table 1 as "Maximum 'f' in gusset." An example of calculation of "Maximum 'f' in gusset" is also given in the Appendix.

There was no established analysis procedure for determining the maximum shear stress in a plane parallel to the glue line. It was known, of course, that the axial and bending loads in the framing member were transferred to the gussets through shear stresses in the glue line. However, since the shear stresses produced in the glue line by the bending load in the members were not uniformly distributed, it

was necessary to make some assumptions regarding their distribution. It seemed reasonable to assume that the component of the shear stress produced by the bending load in the framing members might be calculated by using the standard torsion formula $s = \frac{Tc}{J}$. The shear stress required to transfer the axial load in the framing member was assumed to be uniformly distributed over the glue line area. On the basis of these assumptions, the maximum shear stress in a plane parallel to the glue line was calculated for each of the joints of Table 1 and recorded as "Shear 's' in glue line" (see example in Appendix).

After the theoretical stresses at the time of failure for all joints tested were calculated, the next step was to determine whether the behavior of the joints could have been predicted by applying the tentative design procedure. This was done by comparing the calculated stress at failure from the tests with acceptable stress values as established in the tentative design procedure (Table 1). Each joint was rated as satisfactory or unsatisfactory on each of the three design criteria as proposed in the tentative design procedure. Note that in applying the criterion for "f" in gusset to the test joints it was necessary to compare "f" in gusset with "f" in stud rather than to use the value of 5,180 p.s.i. as allowable. An examination of the data for the second joint in Table 1 illustrates why this procedure was necessary. Notice that at failure "Maximum 'f' in gusset" was 5,579 p.s.i., which is over the established allowable value of 5,180 p.s.i. However, note also that "Maximum 'f' in stud" at failure was 6,373 p.s.i., which is considerably in excess of the average expected strength of such a member, 5,180 p.s.i. Obviously at the time the stress in the stud was 5,180 p.s.i., the stress in the gusset would be less than 5,180 p.s.i. since the two are directly related. Therefore the design procedure is satisfied on this point if "f" in gusset is less than "f" in stud.

In order for one of the tested joints to receive an over-all or composite rating of satisfactory, it had to receive a rating of satisfactory on each of the three criteria of the design procedure. Four joints — numbers 4, 5, 10, and 14 — developed high enough stresses in the stud to receive a satisfactory rating on this point, but they received a composite rating of unsatisfactory because calculated stress in either "f" or "s" in the gusset was above established maximums. This means either that the established maximums are a little low or that these particular joints were stronger than average. If the established maximums are a little low, this is not serious because it is a good idea to be on the conservative side with the design of the gussets.

Notice that in every case where both "f" in the gusset and "s" in

the gusset are rated satisfactory, the joint received an over-all rating of satisfactory. Thus the tentative design procedure could have been used to correctly predict the behavior of each of these joints.

Final Design Procedure

In working with the tentative joint design procedure and verifying it on the joints that had been load-tested, ultimate stress values were used. These were used because only ultimate stresses or stresses at failure could be calculated for the joints that were load-tested since only the load at failure was available from the test data. While ultimate allowable stress values could be used in design by applying appropriate factors of safety, it is more common and probably simpler to use allowable working stresses. Therefore the suggested final design procedure in terms of working stresses is as follows:

1. Joint must be strong enough to develop the allowable working stress for the grade of framing being used. For example, design specifications would commonly suggest a value of 1,500 p.s.i. for construction-grade Douglas fir.
2. The calculated maximum fiber stress in the gusset must not be over the allowable fiber working stress for the grade of plywood used. For C-C exterior-sheathing-grade plywood, design specifications would commonly suggest a value for allowable fiber working stress of 1,875 p.s.i.
3. The calculated maximum shear in a plane parallel to the glue line must not be over the allowable working stress value. On the basis of work reported by Radcliffe (2), a value of 90 p.s.i. is suggested for allowable working stress in shear in a plane parallel to the glue line.

Other Test Results and Observations

Effect of Orientation of Grain of the Plywood

Data for the joints that were load-tested to evaluate the effect of orientation of the grain of the plywood gussets are shown in Table 2. Five orientations of the grain of the plywood with respect to the grain of the stud member were included: 0, 22.5, 45, 67.5, and 90 degrees. The value for "Maximum 'f' in stud" was used as a measure of the relative strength of the joints. An analysis of variance indicated that the orientation of the grain of the plywood had a significant effect on the strength of the joint at the 1-percent level. The least significant difference between mean values of joint strength was found to be 686 p.s.i. at the 5-percent level.

Examination of the mean values of joint strength for the various angles of grain indicates the 22.5-degree orientation to be the strongest with the 0-degree orientation being somewhat weaker. Assuming that the maximum fiber stress in the gusset acts in a direction normal to the "assumed line of failure" of the gusset, as indicated in Fig. 10, the average direction of the maximum fiber stress in the joints tested was inclined about 10 to 12 degrees to the axis of the stud. One would expect therefore that the gussets having grain inclined at 0 and 22.5 degrees to the axis of the stud would be of about equal strength and would be the two strongest joints of those tested. No explanation can be given for the fact that joint 0 appears to be somewhat weaker than joint 22.5. Joints with 45, 67.5, and 90 degree orientations of grain are weaker joints, as one would expect.

On the basis of these tests, it is reasonable to conclude that gussets having orientations of grain of the face plies that are inclined more than perhaps 15 to 20 degrees to the direction of maximum fiber stress are appreciably weaker than gussets having grain of face plies approximately parallel to the direction of maximum fiber stress.

Effect of Direction of Load on Joint Strength

The joint design procedure was established on the basis of tests that produced compression in the unsupported edge of the gusset. This is, of course, the type of load that would be produced by snow or dead load on the roof of a structure. Under some conditions, however, wind loads may reverse the direction of the load on the joints and produce tension in the unsupported edge of the gusset. For this reason a series of joints were tested to determine the effect of direction of load on joint strength (Table 3).

The joints included in the tests reported in Table 3, Part A, were exactly the same as seven of the joints listed in Table 1. The only difference between these tests and those reported in Table 1 was in the direction of loading. A comparison of values for "Maximum 'f' in stud" for the joints of Table 3, Part A, and for the corresponding joints of Table 1 shows that on the average the stress in the stud at failure was approximately the same in both tests. It seems reasonable to conclude that the joints have about the same strength regardless of direction of loading.

The joints included in the tests reported in Table 3, Part B, were exactly the same as the joints listed in Table 2. The only difference between the tests was again in the direction of loading. A comparison of values for "Maximum 'f' in stud" in the two test series indicates that in every case the joint was somewhat stronger when loaded as the

joints in Table 3 were loaded. It seems reasonable to conclude that the joints are at least as strong when loaded to produce tension in the unsupported edge of the gusset as when loaded to produce compression in the unsupported edge of the gusset.

Buckling of the Edge of the Plywood Gussets

As mentioned earlier, a 2 x 4 block was nailed between the unsupported edges of the $\frac{3}{8}$ -inch gussets to support these edges against buckling. This system of support proved to be entirely satisfactory. No support was provided for the edges of the $\frac{5}{8}$ -inch gussets, and the tests verified the fact that none was required.

References

1. Rigid frames for fir plywood structures. Plywood Manufacturers Association of British Columbia. 1955.
2. Design of nail-glued plywood gusset plates and solid wood splice plates for softwoods. Radcliffe, B. M., and Granum, Hans. Purdue (Ind.) Agr. Exp. Sta. Bul. 613. 1954.
3. Design and testing of rigid frames with nailed plywood gusset plates. Petry, W. L. Laboratory Report 76, Douglas Fir Plywood Association. 1958.
4. Wood handbook. Handbook No. 72, U. S. Department of Agriculture. 1955.
5. Statistical approach to working stresses for lumber. Snodgrass, J. D. Proceedings of American Society of Civil Engineers, Vol. 85, No. ST2:9-43. 1959.

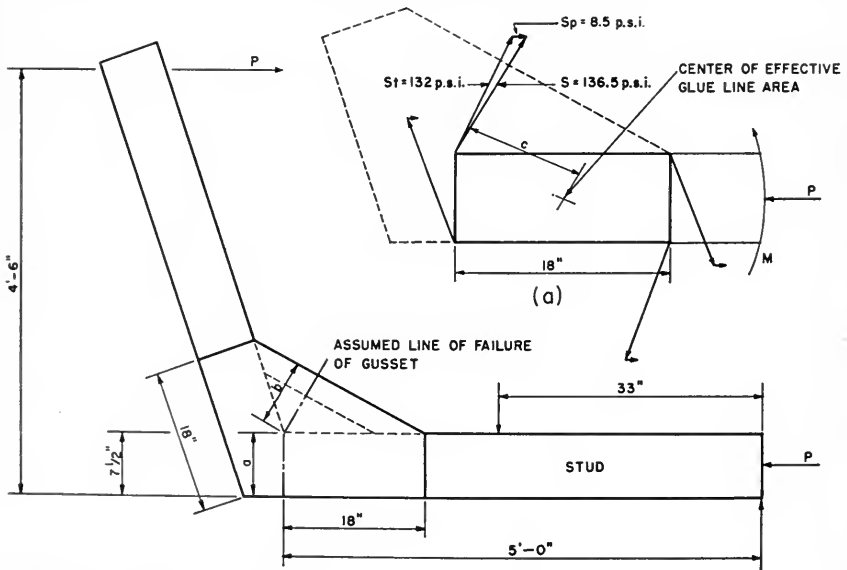

Details of joint: 2 x 8- $\frac{3}{8}$ -18-0.

(Fig. 10)

Appendix

Calculations Sheet for Joint: 2 x 8-3/8-18-0 (see also Fig. 10)

Maximum "f" in Stud

$$f = \frac{M}{S} + \frac{P}{A} = \frac{115,900}{15.23} + \frac{2,307}{12.19}$$

$$f = 7,799 \text{ p.s.i.}$$

P = 2,307 lb. = Applied external load

M = Maximum moment in stud

$$M = 2,307 \times \left(54.0 - \frac{7.5}{2} \right) = 115,900 \text{ in. lb.}$$

S = 15.23 cu. in. = Section modulus of 2 x 8

A = 12.19 sq. in. = Area of 2 x 8

Maximum "f" in Gusset

M = 115,900 in. lb.

P = 2,307 lb.

$$f = \frac{M}{S} + \frac{P}{A} = \frac{115,900}{16.5} + \frac{2,307}{6.18}$$

$$f = 7,397 \text{ p.s.i.}$$

Assume that critical section is at assumed line of failure.

d = a + b = 16.0 in. effective depth of gusset

t = .0965 x 4 = .386 in. thickness of four effective plies

$$S = \frac{td^2}{6} = \frac{.386 \times 16.0^2}{6} = 16.5 \text{ cu. in. section modulus}$$

A = 16 x .386 = 6.18 sq. in. effective cross-sectional area

Shear "s" in Plane Parallel to the Glue Line

M = 115,900 in. lb.

P = 2,307 lb.

$$c = \sqrt{3.75^2 + 9.0^2}$$

$$c = 9.76 \text{ in.}$$

Consider load to be transmitted from stud to gusset.

Moment in stud produces shear stresses in plane parallel to glue bond which form a resisting couple (Fig. 10a).

These shear stresses are assumed to vary from zero at center of effective glue line area to a maximum at distance "c" from this center.

Maximum shearing stress required to form the resisting couple may be calculated from the torsion formula.

s_t = Component of shear due to twisting moment

T = M = Twisting moment

J = $\frac{bh(b^2 + h^2)}{12} \times 2$ = Polar moment of inertia of effective glue line area of two gussets

$$J = 8,556 \text{ in.}^4$$

$$s_t = \frac{115,900 \times 9.76}{8,556}$$

$$s_t = 132 \text{ p.s.i.}$$

$$s_p = \frac{P}{A}$$

$$s_p = \frac{2,307}{270} = 8.5 \text{ p.s.i.}$$

s_p = Component of shear stress required to resist load P

A = 2 x 7.5 x 18.0 = 270 sq. in. glue line area

$$s = 136.5 \text{ p.s.i., resultant shear from components } s_t \text{ and } s_p$$

Summary

Rigid frames are well suited for farm-building construction and have been used in such construction in increasing numbers in recent years. Most of the rigid frames used in the past were factory-fabricated from steel or laminated wood. There is a need for designs for frames that can be constructed by local builders from stock lumber materials.

In the summer of 1957, work was begun on the development of designs for lumber rigid frames. The objective of the first phase of this work was to develop a procedure for designing plywood gussets used to form the joints of lumber rigid frames. Load tests were made on 88 full-scale joints formed with nailed and glued plywood gussets. The results of these tests were then used as a basis for establishing a joint design procedure.

The study indicated that nailed and glued plywood gussets can be satisfactorily used to form rigid joints between straight dimension-lumber members of rigid frames.

The required size and thickness of the plywood gussets needed for a given rigid frame design can be determined analytically. The gussets should be designed to develop the allowable working stress in the framing without the gusset plate stresses in extreme fiber or in shear parallel to the glue line being above allowable working values.

Although the design procedure was developed on the basis of tests made of joints fabricated with $\frac{3}{8}$ - and $\frac{5}{8}$ -inch plywood, there is no reason why it would not apply equally well to $\frac{1}{2}$ -inch plywood.

Support against buckling is not required for the unsupported edges of $\frac{5}{8}$ -inch plywood in the range of gusset plate sizes included in these tests, but is required for the $\frac{3}{8}$ -inch gussets. This support may be satisfactorily provided by nailing a 2 x 4 block between the unsupported edges of the two gussets required for a joint.

The technique for making nailed and glued joints as proposed by Radcliffe (2) and used in these tests was found to be entirely satisfactory.

When joints are loaded to produce tension in the unsupported edge of the gusset, they are at least as strong as when loaded to produce compression in the unsupported edge.

The orientation of the grain of the face plies of plywood gussets has a significant effect on strength of the joint. Orientations that are inclined more than perhaps 15 to 20 degrees to the direction of maximum fiber stress in the gusset are significantly weaker than orientations that are approximately parallel to the direction of the maximum fiber stress.

AUTHOR INDEX

BULLETIN

BATEMAN, H. P.....	645
BAULING, F. W.....	649
BIGGER, J. H.....	641
BLANCHARD, R. A.....	641
BROWNING, D. R.....	643
CAPENER, W. N.....	647
CATE, H. A.....	640
CURTIS, J. O.....	654
DAVIS, V. W.....	638
GARD, L. E.....	640
HANSEN, E. L.....	649
HARRISON, R. L.....	652
HITTLE, C. N.....	643
JONES, B. A., JR.....	640
JOOS, L. A.....	650
JUGENHEIMER, R. W.....	652
KOEHLER, BENJAMIN.....	639
LANGHAM, M. R.....	653
LENG, E. R.....	651
McKIBBEN, G. E.....	640, 643
MUTTI, R. J.....	653
RODDA, E. D.....	649
ROSS, G. L.....	651
ROSS, R. C.....	647
SCHUMAIER, C. P.....	648
TRACY, P. H.....	646
VAN ARSDALL, R. N.....	638, 642
WEBB, R. J.....	640
WILLIAMS, K. E.....	652
WILLS, J. E.....	638
WILSON, H. K.....	646
WITTER, L. D.....	646

SUBJECT INDEX

BULLETIN

Aluminum roof sections.....	649
Animal gains on irrigated pasture.....	640
Artificial drying of corn.....	638
Beef cattle, self-feeding silage to.....	642
Buildings	
low-cost roof for.....	649
lumber rigid frames for.....	654
Cattle, beef, self-feeding silage to.....	642
Chickens, commercial laying flocks.....	647
Corn	
commercial hybrids performance in 1959.....	651
costs of field-shelling and artificial drying.....	638
dwarf hybrids	651
ear rots	639
effect of moisture losses on costs of storing.....	653
effect of tillage and soil compaction on production of.....	645
experimental hybrids performance in 1959.....	652
high-oil hybrids	652
increased planting rate.....	651
prices related to those of wheat.....	648
underground insects of.....	641
Costs	
field-shelling and artificial drying of corn.....	638
laying flocks	647
storing ear corn, as affected by moisture losses.....	653
Custom work for field-shelling and artificial drying.....	638
Diseases of corn, ear rots.....	639
Dixon Springs Station, irrigation of pastures at.....	640
Drying, artificial, of corn.....	638
Ear rot diseases of corn.....	639
Egg production and returns.....	647
Feed, artificially dried corn for.....	638
Field-shelling of corn, costs of.....	638
Freeze probabilities in Illinois.....	650
Grain sorghums, 1958 performance tests.....	643
Hybrid corn, see Corn	
Income from laying flocks.....	647
Insecticides to control underground corn insects.....	641
Insects, underground, of corn.....	641
Irrigation of pasture.....	640

Labor in self-feeding silage to cattle.....	642
Ladino clover-grass pasture, irrigation of.....	640
Landlord-tenant arrangements for sharing costs of shelling and drying corn.....	638
Laying flocks, economic performance of.....	647
Lodging, influencing corn ear rots.....	639
Lumber rigid frames for farm buildings.....	654
Marketing of corn, implications of field-shelling and drying.....	638
Milk, keeping quality of pasteurized Grade A in Chicago.....	646
Moisture losses affecting cost of storing ear corn.....	653
Oat prices related to those of wheat.....	648
Pasture, Ladino clover and grass, irrigation of.....	640
Plywood gussets for lumber rigid frames.....	654
Prices of wheat, corn, oats, and soybeans.....	648
Roof, low cost, for small farm buildings.....	649
Silage, self-feeding to beef cattle.....	642
Silos, horizontal.....	642
Soil compaction, effect on corn production.....	645
Soil treatment, related to irrigation.....	640
Sorghums, grain, 1958 performance tests.....	643
Soybean prices related to those of wheat.....	648
Storing ear corn, moisture losses.....	653
Storing shelled corn, economics of.....	638
Tillage, effect on corn production.....	645
Weather	
affecting moisture losses in stored corn.....	653
freeze probabilities in Illinois.....	650
rainfall influencing corn ear rots.....	639
Wheat acreage and production.....	648









UNIVERSITY OF ILLINOIS-URBANA

Q 630.71L68

C002

BULLETIN, URBANA

638-654 1959-60



3 0112 019529434