

LIBRARY
Brigham Young University



IN MEMORY OF
James Dunn
Gift of

Alex F. & Carol H. Dunn
and their children

Joel James Dunn
Loren Charles Dunn
Carolyn Dunn Newman
(and his descendants)

Digitized by the Internet Archive
in 2011 with funding from
Brigham Young University

THIS BOOK OF TYPE SPECIMENS
AND PRINTING INFORMATION IS
FOR THE PRINTERS' DESK—FOR
DAILY USE AND FOR REFERENCE

Z
250
.A53
1700

DESK BOOK OF TYPE SPECIMENS

Borders & Ornaments
Brass Rules and Cuts

Catalogue of
Printing Machinery and
Printers' Supplies

—
1900

AMERICAN
TYPE FOUNDERS COMPANY

Everything for the Printer



ST LOUIS



NEW YORK

Manufacturing Foundries of American Type Founders Company



PHILADELPHIA



BOSTON



CHICAGO

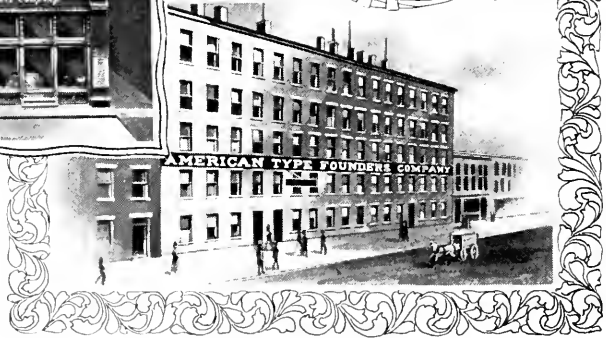

CINCINNATI

TO THE PRINTER:



THE Type and Borders shown in this specimen book excel in design—the chief merit of type—and their durability is assured by the use of the celebrated Copper Alloy Type Metal

* The selection of styles of Type illustrated in this book excels in both variety and utility the combined product of all other type foundries * * * * *

* A printing office completely supplied with the products of this Company is worth far more for either use or sale than one made up from the productions of incomplete type foundries * * * * *

* It is conceded that the Type made by this Company is the STANDARD for excellence throughout the world. Every endeavor is made to advance that standard * * * * *

* As the largest purchaser of Printing Machinery and Materials in the world, this Company commands the best of everything for the printer, and has unsurpassed facilities for meeting the requirements of printing offices * * * * *

AMERICAN TYPE

FOUNDERS COMPANY

October, 1900

BRANCH HOUSES OF THE
AMERICAN TYPE
FOUNDERS CO.

CHICAGO, 203-205 E. Monroe Street

MINNEAPOLIS, 24-26 First Street, South

BOSTON, 270 Congress Street

NEW YORK, Rose and Duane Streets

PHILADELPHIA, 606-614 Sansom Street

BALTIMORE, Frederick and Water Streets

BUFFALO, 45 N. Division St., cor. Ellicott

PITTSBURGH, 323 Third Avenue

CLEVELAND, 255-259 St. Clair Street

CINCINNATI, 124 E. Sixth Street

DENVER, 1649 Blake Street

ST. LOUIS, Fourth and Elm Streets

KANSAS CITY, 612 Delaware Street

SPOKANE, 10 Monroe Street

PORTLAND, ORE., Second and Stark Sts.

SAN FRANCISCO, 405-407 Sansome Street

LOS ANGELES, 105 N. Broadway



CLASSIFIED INDEX

| PART | PAGE |
|--|---------|
| I.—BODY LETTER Shown by Sizes and in Series ranging from 3½ Point to 18 Point | I-140 |
| II.—CIRCULAR LETTER | 145-176 |
| III.—SCRIPT TYPE | 185-220 |
| IV.—ITALIC STYLES | 225-272 |
| V.—MODERN JOBBING TYPE | 273-344 |
| VI.—STANDARD JOBBING TYPE | 351-398 |
| VII.—LIGHTWEIGHT AND ORNAMENTAL JOBBING TYPE, RUNICS AND CELTICS | 401-436 |
| VIII.—TWO-COLOR AND CONTOUR TYPE STYLES | 451-478 |
| IX.—OLD STYLE AND MODERN ROMAN JOBBING SERIES, LIGHTFACE AND TWO-LINE LETTER, BOLDFACE ROMAN, TITLE AND CONDENSED TITLE | 483-530 |
| X.—ANTIQUE, CALEDONIAN, CLARENDON, DORIC AND IONIC . . . | 541-572 |
| XI.—GOTHICS | 581-620 |
| XII.—SHADED TYPE, TEXT AND BLACK LETTER | 625-644 |
| XIII.—GERMAN, HEBREW, GREEK, RABBINIC, ARMENIAN AND RUSSIAN | 649-682 |
| XIV.—MUSIC TYPE, MAIL LIST TYPE, TIME-TABLE FIGURES, SIGNS, SUPERIOR AND INFERIOR LETTERS AND FIGURES, FRACTIONS AND PIECE FRACTIONS, CALENDARS, SIGNAL FLAGS AND WEATHER INDICATORS, CHESSMEN AND CHECKERS, CARD PIPS, CARD INDICATORS, WHIST MARKERS, RECIPE MARKS, FIVE-POINTED STARS, MALTESE CROSSES, METAL BRACES AND DASHES, ANGULAR QUADS, CIRCULAR QUADS, CORNER QUADS, METAL FURNITURE, AND LEADS AND SLUGS | 691-720 |

| PART | PAGE |
|---|----------------------|
| XV.—BORDERS AND ORNAMENTS | 721-788 ^h |
| XVI.—INITIAL LETTERS, NEWSPAPER HEADINGS AND SUB-HEADINGS, DATE LINES, CHECK BLANKS, COMMERCIAL AND BILL- HEAD LOGOTYPES | 791-808 |
| XVII.—CAST AND ELECTROTYPED CUTS, SOCIETY AND PATRIOTIC EMBLEMS, STATE SEALS AND BUSINESS CUTS | 809-876 |
| XVIII.—BRASS RULE, BRASS DASHES, BRASS LEADERS, PERFORATING, SCORING AND CUTTING RULES, BRASS CIRCLES AND OVALS, AND BRASS TYPE | 881-900 |
| XIX.—WOOD TYPE, WOOD RULE AND WOOD BORDERS | 901-924 |
| XX.—CATALOGUE AND PRICE LIST OF PRINTING MACHINERY AND PRINTERS' SUPPLIES, WOOD GOODS, AND PRINTING INKS | 931-1096 |
| XXI.—USEFUL INFORMATION FOR PRINTERS—HINTS ON IMPOSITION OF FORMS—PRICE LIST OF PRINTING AND BINDING . . . | 1101-1144 |
| XXII.—CONDENSED PRICE LIST WITH CODE WORDS—INDEX AND PRICE LIST OF CUTS | 1145-1187 |

OUR PRODUCTIONS
ARE CAST FROM
COPPER-ALLOY METAL
ACKNOWLEDGED TO BE THE
LIGHTEST AND MOST DURABLE

INDEX TO TYPE SPECIMENS

| | PAGE | | PAGE | | PAGE |
|---------------------------------------|---------|----------------------------------|----------|--------------------------|------|
| Acanthine Florets | 779 | Binner Gothic | 344 | BORDERS—Continued | |
| Acorn Initials | 792 | Binner Open | 455 | —Holly | 761 |
| Advertising Figures | 708-710 | Binny Old Style No. 77 | 106, 107 | —Ipsen | 757 |
| Advertising Rules | 894 | Black No. 11 | 641 | —Klondike | 765 |
| Alaskan | 374 | Black No. 12 | 633 | —Laurel | 752 |
| Alfereta | 249 | Black No. 13 | 641 | —Manila | 763 |
| Algebraic Signs No. 150-608 | 600 | Black No. 22 | 641 | —Murtle | 760 |

ADDENDA

Type Specimens:

| | PAGE | | PAGE |
|---|------------|--|------------|
| Mortised Initial Ornaments | 790a | Poster French Old Style Extended | 178n, 178o |
| Post Bands | 788d | Poster Ionic No. 122 | 178i, 178k |
| Poster Antique No. 125 | 178g, 178h | Poster Latin Antique No. 120 | 178c, 178d |
| Poster De Vinne | 178t, 178u | Poster Lightface No. 158 | 178a, 178b |
| Poster De Vinne Condensed | 178r, 178s | Poster Old Style Antique No. 120 | 178l, 178m |
| Poster De Vinne Extra Condensed | 178p, 178q | Poster Schœffer Old Style | 178v-178x |
| Poster Eastman | 178e, 177f | | |

Machinery Catalogue:

| | PAGE |
|--------------------------------------|-------------|
| Weatherly Extension Blocks | 1078a-1078d |

| | | | | | |
|--------------------------------------|----------|-------------------------------|-------------------|-------------------------------------|------------------------------------|
| Aquaint | 627 | BORDERS: | | Braces, Brass | 897 |
| Archaic | 384, 385 | —Art | 727-732 | —Metal | 718 |
| Arithmetical Signs No. 150 | 698 | —Barta | 748, 749 | Bradley | 284, 285 |
| Arlington | 289-291 | —Barth Geometrical | 770 | Bradley Extended | 280-283 |
| Armenian | 677 | —Brier | 761 | Bradley Initials | 794 |
| Army and Navy Series | 809 | —Caxton | 743 | Bradley Italic | 240, 241 |
| Arrows | 717 | —Central Bands | 732 | Bradley Italic Outline | 457 |
| Art Borders | 727-732 | —Collins Bands | 741-743 | Bradley Outline | 456 |
| Art Gothic | 387 | —Collins | 740 | Brass Braces | 897 |
| Art Initials | 795 | —Combination Border | | Brass Circles | 898, 899 |
| Astronomical Signs | 699, 700 | Series 98 | 772, 773 | Brass Column Rules | 895 |
| Athletes | 815 | —Contour | 750, 751, 753-756 | Brass Dashes | 896 |
| Atlanta | 375 | —Coptic | 757 | Brass Dash Rules | 894 |
| Augustan Text | 642 | —Daisy | 733 | Brass Date Lines | 804 ^a |
| Autograph Script | 218 | —Darling | 733 | Brass Diamonds | 899 |
| Ballet Dancers | 812 | —Eighteen Point | 726, 738, 759 | Brass Head Rules | 894 |
| Barta Borders | 748, 749 | —Elzevir | 746, 747 | Brass Leaders | 897 |
| Barth Geometrical Borders | 770 | —Empire | 758 | Brass Leads and Slugs | 895 |
| Baseball, Series I | 810 | —End-wood | 903 | Brass Newspaper Head- | |
| Bearers | 715 | —Flag | 755, 760 | ings | 804 ^a -804 ^d |
| Bijou | 167 | —Flame | 764 | Brass Ovals | 899 |
| Billhead Logotypes | 805 | —Floral | 761 | Brass Perforating Rules | 891 |
| Binner | 273-275 | —Florentine | 744, 745 | Brass Rules, Labor-Saving | 892, 893 |
| | | —Half-Nonpareil | 721 | | |

| PART | PAGE |
|---|----------------------|
| XV.—BORDERS AND ORNAMENTS | 721-788 ^h |
| XVI.—INITIAL LETTERS, NEWSPAPER HEADINGS AND SUB-HEADINGS, DATE LINES, CHECK BLANKS, COMMERCIAL AND BILL- HEAD LOGOTYPES | 791-808 |
| XVII.—CAST AND ELECTROTYPED CUTS, SOCIETY AND PATRIOTIC EMBLEMS, STATE SEALS AND BUSINESS CUTS | 809-876 |
| XVIII.—BRASS RULE, BRASS DASHES, BRASS LEADERS, PERFORATING, SCORING AND CUTTING RULES, BRASS CIRCLES AND OVALS, AND BRASS TYPE | 881-900 |

ACKNOWLEDGED TO BE THE

LIGHTEST AND MOST DURABLE

INDEX TO TYPE SPECIMENS

| | PAGE | | PAGE |
|--|----------|--|-------------------------------------|
| Acanthine Florets | 779 | Binner Gothic | 344 |
| Acorn Initials | 792 | Binner Open | 455 |
| Advertising Figures | 708-710 | Binny Old Style No. 77 | 106, 107 |
| Advertising Rules | 894 | Black No. 11 | 641 |
| Alaskan | 374 | Black No. 12 | 633 |
| Alfereta | 249 | Black No. 13 | 641 |
| Algebraic Signs No. 150 | 698, 699 | Black No. 22 | 641 |
| Alpine | 428 | BODY TYPE: | |
| American Press Association Series No. 61 | 51, 71 | German | 650-655 |
| American Script | 185-187 | —Self Spacing | 650 |
| American Typewriter | 145 | Modern Roman and | |
| Angular Quads | 719 | Italic | 6-76 |
| Antique No. 42 | 545 | —Newspaper Style | 63-76 |
| Antique No. 124 | 545 | —Self Spacing | 76, 128-135 |
| Antique No. 125 | 558, 696 | —Shown by Sizes | 6-33 |
| Antique No. 126 | 562 | —Shown by Series | 34-62 |
| Antique No. 127 | 563 | Old Style Roman and | |
| Antique Cond. No. 36 | 542 | Italic | 77-127 |
| Antique Cond. No. 116 | 553 | —Self Spacing | 136-139 |
| Antique Cond. No. 122 | 553, 563 | —Shown by Sizes | 77-100 |
| Antique Cond. No. 123 | 543 | —Shown by Series | 101-127 |
| Antique Cond. No. 124 | 541 | Synopsis | 1-5 |
| Antique Cond. No. 152 | 563 | Boldface No. 114 | 517 |
| Antique Extd. No. 120 | 567 | Boldface No. 120 | 517 |
| Antique Extd. No. 122 | 565 | Boldface Borussian | 671 |
| Antique Extd. No. 123 | 567 | Boldface Celtic | 436 |
| Antique Extd. No. 124 | 565 | Boldface German | 660 |
| Antique Extra Condensed | | Boldface Italic No. 15 | 253 |
| No. 150 | 559 | Boldface Italic No. 22 | 252 |
| Antique Fractions | 705 | Boldface Italic No. 23 | 252 |
| Antique Pointed No. 120 | 572 | Boldface Italic No. 27 | 253 |
| Apollo | 164 | Boldface Italic No. 120 | 252 |
| Apple-Blossom Ornaments | 777 | Boldface No. 120 Fractions | 705 |
| Aquatint | 627 | BORDERS: | |
| Archaic | 384, 385 | —Art | 727-732 |
| Arithmetical Signs No. 150 | 698 | —Barta | 748, 749 |
| Arlington | 289-291 | —Barth Geometrical | 770 |
| Armenian | 677 | —Brier | 761 |
| Army and Navy Series | 809 | —Caxton | 743 |
| Arrows | 717 | —Central Bands | 732 |
| Art Borders | 727-732 | —Collins Bands | 741-743 |
| Art Gothic | 387 | —Collins | 740 |
| Art Initials | 795 | —Combination Border | |
| Astronomical Signs | 699, 700 | Series 98 | 772, 773 |
| Athletes | 815 | —Contour | 750, 751, 753-756 |
| Atlanta | 375 | —Coptic | 757 |
| Augustan Text | 642 | —Daisy | 733 |
| Autograph Script | 218 | —Darling | 733 |
| Ballet Dancers | 812 | —Eighteen Point | 726, 738, 759 |
| Barta Borders | 748, 749 | —Elzevir | 746, 747 |
| Barth Geometrical Borders | 770 | —Empire | 758 |
| Baseball, Series 1 | 810 | —End-wood | 903 |
| Bearers | 715 | —Flag | 755, 760 |
| Bijou | 167 | —Flame | 764 |
| Billhead Logotypes | 805 | —Floral | 761 |
| Binner | 273-275 | —Florentine | 744, 745 |
| | | —Half-Nonpareil | 721 |
| | | BORDERS—Continued | |
| | | —Holly | 761 |
| | | —Ipsen | 757 |
| | | —Klondike | 765 |
| | | —Laurel | 752 |
| | | —Manila | 763 |
| | | —Myrtle | 760 |
| | | —Newspaper | 734-738, 759 |
| | | —Nonpareil | 722, 723 |
| | | —Nonpareil and One-Half | 724 |
| | | —Palm Border | 778 ^b |
| | | —Pica | 724, 725, 739 |
| | | —Point Combination, Series A and B | 778 ^d , 778 ^e |
| | | —Pointer | 733 |
| | | —Polka-Dot | 732 |
| | | —Primrose | 759 |
| | | —Red, White and Blue | 754 |
| | | —Regal | 733 |
| | | —Rococo | 759 |
| | | —Rustic Band | 732 |
| | | —Thirty Point | 759 |
| | | —Thirty-six Point | 726 |
| | | —Three-line Nonpareil | 726 |
| | | —Tiger Lily | 778 ^c |
| | | —Twelve Point | 724, 725, 739 |
| | | —Twenty-four Point | 726, 739 |
| | | —Twinkler | 778 ^c |
| | | —Two Color | 753, 756 |
| | | —Union | 755 |
| | | —Wood | 903 |
| | | Boston Black | 632 |
| | | Boston Script | 192, 193 |
| | | Bowlers | 809 |
| | | Braces, Brass | 897 |
| | | —Metal | 718 |
| | | Bradley | 284, 285 |
| | | Bradley Extended | 280-283 |
| | | Bradley Initials | 794 |
| | | Bradley Italic | 240, 241 |
| | | Bradley Italic Outline | 457 |
| | | Bradley Outline | 456 |
| | | Brass Braces | 897 |
| | | Brass Circles | 898, 899 |
| | | Brass Column Rules | 895 |
| | | Brass Dashes | 896 |
| | | Brass Dash Rules | 894 |
| | | Brass Date Lines | 804 ^a |
| | | Brass Diamonds | 899 |
| | | Brass Head Rules | 894 |
| | | Brass Leaders | 897 |
| | | Brass Leads and Slugs | 895 |
| | | Brass Newspaper Headings | 804 ^a -804 ^d |
| | | Brass Ovals | 899 |
| | | Brass Perforating Rules | 891 |
| | | Brass Rules, Labor-Saving | 892, 893 |

| | PAGE | | PAGE | | PAGE |
|--|------------------|---|----------|---|----------|
| Brass Rules, Strips | 881-891 | Columbus No. 2 | 306, 307 | Dashes, Brass | 896 |
| Brass Scoring Rules | 891 | Columbus Outline | 460, 461 | —Metal | 718 |
| Brass Space Rule | 891 | Columbus Outline Initials, 461 | | Dash Rules, Brass | 894 |
| Brass Type | 900 | Column Rules | 895 | Date Lines, Electrotyped | |
| Breton | 544 | Combination Border Series | | | 806, 807 |
| Brier Border | 761 | 98 | 772, 773 | Delmonico Chefs and Wait- | |
| Cadet | 641 | Combination Cond. Gothic | | ers | 810 |
| Caledonian Fractions | 705 | Nos. 161 to 166 | 596 | Devens Script | 208, 209 |
| Calendar Figures | 706, 707 | Combination Gothic Nos. | | De Vinne | 330-333 |
| Calendars, Sectional | 711-713 | 110 to 120 | 595 | De Vinne Condensed | 334-337 |
| —Perpetual Logotype 712, 713 | | Combination Gothic Nos. | | De Vinne Condensed Frac- | |
| Caligraph | 148 | 151 to 159 | 596 | tions | 704 |
| Camelot Old Style | 402-405 | Combination Gothic Nos. | | De Vinne Extended | 327-329 |
| Campaigners | 812, 924 | 1521 to 1533 | 598 | De Vinne Extra Cond. 338, 339 | |
| Cancelled Figures | 701 | Combination Italic Gothic | | De Vinne Fractions | 704 |
| Card Indicators | 717 | Nos. 131 to 150 | 247 | De Vinne Italic | 244, 245 |
| Card Mercantile | 408, 409 | Combination Ornaments | 776 | De Vinne Italic Outline, 462, 463 | |
| Card Ornaments | 777 ^b | Commercial Logotypes | 805 | De Vinne Shaded | 471 |
| Card Pips | 717 | Commercial Signs No. 150 | | Dewey Ornaments | 763 |
| Carpenter Script | 211 | | 698, 705 | Diagonal Fraction Marks | 702 |
| Caslon Condensed | 311 | Composite No. 30 | 670 | Domestics | 813 |
| Caslon Old Style No. 71 | | Composite No. 150 | 670 | Doric No. 120 | 548 |
| 104, 105, 483-487 | | Composite Condensed | 671 | Doric Fractions | 705 |
| Caslon Old Style Italic | | Condensed No. 45 | 522 | Doric Italic | 225 |
| No. 71 | 262, 263 | Condensed No. 124 | 522 | Dotlet Ornaments | 771 |
| Cast Initials | 790, 794, 795 | Condensed Aldine No. 150. 519 | | Douglas | 383 |
| Caxton Black | 634, 635 | Condensed Black No. 42 | 643 | Dresden | 426 |
| Caxton Bold | 318, 319 | Cond. Black Shaded No. 40 643 | | Druggists | 811 |
| Caxton Borders | 743 | Cond. Clarendon No. 42 | 551 | Duerer | 354 |
| Caxton Old Style | | Condensed German Black | | Dynamo | 388 |
| 118, 119, 491-491 ^b | | No. 150 | 659 | Earle Typewriter | 147 |
| Caxton Old Style Italic | 269 | Condensed Title No. 46 | 524 | Eastman | 320, 321 |
| Celtic No. 3 | 422 | Condensed Title No. 104 | 525 | Eccentric | 398 |
| Central Antique | 560 | Condensed Title No. 123 | 518 | Ecclesiastical Signs | 698 |
| Central Bands | 732 | Condensed Title No. 124 | 520 | Edinburgh Title | 501 |
| Central Ornaments | 775, 778 | Cond. Title No. 125 | 524, 525 | Egyptian Ex. Cond. No. 120 571 | |
| Century | 431 | Contour No. 1 | 472 | Egyptian Ornaments | 762 |
| Century Roman | 61 | Contour No. 2 | 476 | Eighteen Point Borders | |
| Century Roman No. 2 | 62 | Contour No. 3 | 476 | 726, 738, 759 | |
| Chamfer Condensed | 610, 611 | Contour No. 4 | 475 | Elandkay | 401 |
| Chapel Text No. 30 | 644 | Contour No. 5 | 477 | Elberon No. 2 | 378 |
| Check Blanks | 808 | Contour No. 6 | 473 | Election Signs | 718 |
| Checkers | 716 | Contour No. 7 | 474 | Electric Ornaments | 771 |
| Chelsea Circular | 172 | Contour Bands and Borders | | Electrotyped Date Lines | |
| Chessmen | 716 | 750, 751, 753, 756 | | 806, 807 | |
| Chicago Script | 217 | Contour Palmetto Orn'm'ts 775 | | Electrotyped Initials | 791-793 |
| Childs | 370 | Contour Pointers | 774 | Electrotyped Newspaper | |
| Christmas Ornaments | 769 | Copper-Alloy Fine-Dot | | Headings 796-800 ^e | |
| Circles, Brass | 898, 899 | Leaders | 271 | Electrotyped Take Slugs | 719 |
| Circular Commercial | 174, 175 | Copper-Alloy Imprints | 598 | Electrotype Imprints | 598 |
| Circular Gothic No. 120 163, 256 | | Copper-Alloy Take Slugs | 719 | Elzevir Borders, Bands | |
| Circular Italic No. 120 | 162 | Copperplate Roman | 406, 407 | and Ornaments 746, 747 | |
| Circular Quads | 719 | Coppers | 811 | Elzevir Florets | 755, 779 |
| Circular Script | 201 | Coptic Borders | 757 | Elzevir Gothic | 352, 353 |
| Clarendon No. 120 | 550 | Corner Quads | 719 | Elzevir Italic | 268 |
| Clarendon Cond. No. 10 | 552 | Crayon | 629 | Empire Borders | 758 |
| Clarendon Cond. No. 120 | 552 | Cruikshank | 379 | Empire Initials | 794 |
| Clarendon Cond. No. 122 | 553 | Culdee | 398 | Empire Ornaments | 785 |
| Clarendon Lightface | | Cursive Script | 214 | End-wood Borders | 903 |
| No. 30 | 551 | Cushing 124, 125, 154, 414, 415 | | Engraving Blanks | 714 |
| Classic Ornaments | 769 | Cushing Fractions | 704 | Epitaph | 362 |
| Cleveland Script | 211 | Cushing Italic 155, 260, 261 | | Epitaph Open | 469 |
| Collins Bands | 741-743 | Cushing Monotone | 126, 127 | Erebus | 363 |
| Collins Borders | 740 | Cushing Monotone No. 2 | 127 | Erratick | 360 |
| Collins Florets | 780, 781 | Cushing Old Style | 340, 341 | Erratick Outline | 464 |
| Columbian | 386 | Cutting Rules | 719 | Extd. Clarendon No. 30 | 564 |
| Columbus Initials | 307 | Daisy Borders | 733 | Extd. Clarendon No. 32 | 564 |
| | | Darling Borders | 733 | Extra Condensed No. 43 | 530 |

| | PAGE | | PAGE | | PAGE |
|---|--|--------------------------------------|----------|----------------------------------|------------------|
| Extra Condensed No. 123 | 526, 527 | GERMAN— <i>Continued</i> | | Gothic Wide | 618 |
| Extra Condensed No. 234 | 526 | —Full Face | 661 | Gothic Wide No. 2 | 619 |
| Facade | 391 | —Germania No. 150 | 670 | Graphic | 477 |
| Facade Condensed | 393 | —Gothisch | 673 | Greek | 678-682 |
| Facade Condensed No. 2 | 392 | —Heintzemann | 659 | Greek Letters (Job) | 682 |
| Fifth Initials | 791 | —Ihlenburg | 665 | Grimaldi | 424 |
| Fine-Dot Leaders | 271 | —Ihlenburg Extended | 664 | Grolier | 167 |
| Fists | 872 | —Modern Black No. 2 | 673 | Gutenberg | 424 |
| Five-Pointed Stars | 715 | —Modern Fraktur | 658 | Hades | 469 |
| Flag Borders | 755, 760 | —Modern Text No. 2 | 669 | Half Nonpareil Borders | 721 |
| Flame Borders | 764 | —No. 30 | 656 | Half Title No. 120 | 521 |
| Floral Borders | 761 | —No. 31 | 656 | Half Title No. 122 | 521 |
| Florentine Borders | 744, 745 | —No. 32 | 656 | Half-tone | 628 |
| Florentine Heavyface | 326 | —No. 121 | 652-654 | Hamburg | 640 |
| Florentine Old Style No. 2 | 158, 342, 343 | —No. 153 | 651 | Hansard | 428 |
| Foot Slugs | 719 | —No. 155 | 655 | Hapgood Florets | 778 ^r |
| Foster Gothic | 389 | —Schwabacher | 667 | Hapgood Initials | 790 |
| Fourteen Point Typewriter No. 2 | 145 | —Schwabacher No. 2 | 666 | Happy Thoughts | 778 ⁿ |
| FRACTIONS: | | —Self Spacing | 650 | Harper | 430 |
| —Antique | 705 | —Teuton Black | 661 | Harvard Italic | 242, 243 |
| —Boldface No. 120 | 705 | —Teutonic No. 1 | 668 | Head Rules, Brass | 894 |
| —Caledonian | 705 | —Teutonic Extended | 672 | Heavyface Greek | 682 |
| —Cushing | 704 | —Text No. 2 | 672 | Hebrew No. 1 | 674, 675 |
| —DeVenne | 704 | —Title | 663 | Hebrew No. 2 | 676 |
| —DeVenne Condensed | 704 | —Title Cond. No. 30 | 657 | Heintzemann | 659 |
| —Doric | 705 | —Title Cond. No. 150 | 657 | Hermes | 417 |
| —Full Face No. 7 | 705 | —Title No. 2 | 660 | Herriet Script | 210 |
| —Gothic | 705 | —Title No. 122 | 662 | Hoboes | 810 |
| —Gothic Condensed | 705 | German Full Face | 661 | Holly Border | 761 |
| —Piece | 702, 703 | German Gothisch | 673 | Houghton | 378 |
| —Quentell | 704 | German No. 30 | 656 | Howland | 302-395 |
| —Roman | 705 | German No. 31 | 656 | Howland Open | 466, 467 |
| —Self Spacing Piece | 703 | German No. 32 | 656 | Ihlenburg | 665 |
| —Special | 702 | German No. 121 | 652-654 | Ihlenburg Extended | 664 |
| Fraction Marks | 702 | German No. 153 | 651 | Imprints | 598 |
| Franklin Old Style No. 79 | 108-110, 491 ^e , 491 ^d | German No. 155 | 655 | Imprint Gothic No. 121 | 598 |
| French Antique No. 110 | 568 | Germania No. 150 | 670 | Imprint Gothic No. 124 | 598 |
| French Clarendon No. 120 | 570 | German Self Spacing | 650 | Imprint Gothic No. 150 | 598 |
| French Clar. Extd. No. 120 | 569 | German Text No. 2 | 672 | Inclined Antique | 255 |
| French Elzevir No. 1 | 120, 121, 503 | German Title | 663 | Inclined Gothic | 254 |
| French Old Style Extd. | 595 | German Title No. 2 | 660 | Index Cuts | 872 |
| French Old Style No. 1 | 504 | German Title No. 122 | 662 | Index Initials | 791 |
| French Old Style No. 2 | 122, 123, 492-495 | German Title Cond. No. 30 | 657 | Inferior Figures | 702 |
| French Old Style Italic No. 2 | 152, 153, 268 | German Title Cond. No. 150 | 657 | Inferior Letters | 702 |
| French Script | 202-204 | Goth | 389 | INITIALS: | 790-795 |
| Full Face Fractions No. 7 | 705 | Gotham Script | 210 | —Acorn | 792 |
| Full Face No. 123 | 516 | Gothic No. 122 | 603 | —Art | 795 |
| Full Face Italic No. 123 | 253 | Gothic No. 123 | 612 | —Bradley | 794 |
| Furniture, Metal | 720 | Gothic No. 124 | 617 | —Cast | 790, 794, 795 |
| Geometric | 412 | Gothic No. 125 | 613 | —Columbus | 397 |
| Geometric Italic | 413 | Gothic No. 127 | 620, 696 | —Columbus Outline | 461 |
| Geometrical Borders | 770 | Gothic Condens'd Fractions | 705 | —Electrotyped | 791-793 |
| GERMAN: | | Gothic Condensed No. 37 | 600 | —Empire | 794 |
| —Boldface Borussia | 671 | Gothic Condensed No. 112 | 597 | —Fifth | 791 |
| —Boldface German | 660 | Gothic Condensed No. 122 | 601 | —Hapgood | 790 |
| —Composite | 670 | Gothic Condensed No. 123 | 614 | —Index | 791 |
| —Composite Condensed | 671 | Gothic Condensed No. 124 | 615 | —Ipsen | 794 |
| —Condensed German Black No. 150 | 659 | Gothic Condensed No. 127 | 609 | —Jenson | 794 |
| | | Gothic Condensed No. 128 | 608 | —Lenten | 793 |
| | | Gothic Condensed No. 129 | 602 | —Missal | 793 |
| | | Gothic Ex. Cond. No. 122 | 616 | —Morris | 791 |
| | | Gothic Ex. Cond. No. 150 | 611 | —Mortised No. 2 | 795 |
| | | Gothic Fractions | 705 | —Multiple | 793 |
| | | Gothic Italic No. 112 | 246 | —Neptune | 793 |
| | | Gothic Italic No. 113 | 246 | —Noname | 793 |
| | | Gothic Italic No. 123 | 246 | —Renate | 793 |
| | | Gothic Italic No. 124 | 257 | —Schæffer Old Style | 794 |
| | | Gothic Italic Extra Cond. | 255 | | |
| | | Gothic Slope No. 20 | 257 | | |

| | PAGE | | PAGE | | PAGE |
|--|---------------|--|----------|-----------------------------------|------------------------------------|
| INITIALS— <i>Continued</i> | | Labor-saving Leads | 720 | McCullagh | 312, 313 |
| —Series No. 50 | 790 | Labor-saving Metal Fur- | | Mediæval No. 10 | 644 |
| —Series No. 51 | 790 | niture | 720 | Medical Signs No. 150 | 698 |
| —Series No. 52 | 790 | Labor-saving Quotation | | Mercantile | 410, 411 |
| —Series No. 320, Ornam. | 790 | Furniture | 720 | Mercantile Bold | 427 |
| —Series No. 320, Plain | 790 | Labor-saving Slugs | 720 | Metal Braces | 718 |
| —Series No. 321, Ornam. | 790 | Laclede | 250 | Metal Corner Quads | 719 |
| —Series No. 321, Plain | 790 | Ladies' Hand Script | 200 | Metal Furniture | 720 |
| —Series No. 421 | 792 | Lady Speakers | 813 | Midget Tail Pieces | 762 |
| —Series No. 424 | 792 | Lafayette | 357 | Mid Gothic | 604, 605 |
| —Series No. 425 | 792 | Large Face Series No. 54 | | Milan | 170 |
| —Series No. 426 | 792 | 42, 43, 67 | | Miscellaneous Signs | 700, 701 |
| —Series No. 440 | 795 | Latin Antique No. 120 | 557 | Missal Initials | 793 |
| —Series No. 441 | 795 | Latin Compressed No. 30 | 395 | Modern Antique | 554, 555 |
| —Series No. 442 | 791 | Latin Condensed No. 150 | 394 | Modern Antique Wide | |
| —Series No. 1132 | 795 | Latin Extended | 566 | No. 110 | 556 |
| —Series No. 1133 | 795 | Laurel Borders | 752 | Modern Black No. 2 | 673 |
| —Series No. 1136 | 795 | Laurel Ornaments | 767 | Modern Fraktur | 658 |
| —Series No. 1142 | 795 | Laurel Wreaths | 766 | MODERN ROMAN: | |
| —Series No. 1143 | 795 | Law Italic No. 42 | 270 | —No. 17 | 6 |
| —Series No. 1146 | 790 | Law Italic No. 120 | 149, 271 | —No. 18 | 6 |
| —Series No. 1147 | 790 | Law Italic No. 122 | 270 | —No. 46 | 34, 35, 63 |
| —Series No. 1148 | 790 | Leaders, Brass | 897 | —No. 47 | 36-38, 64 |
| —Series No. 1155 | 795 | —Dotted | xvi | —No. 50 | 40, 41, 65 |
| —Series No. 1158 | 791 | —Fine Dot | 271 | —No. 53 | 39, 66 |
| —Series No. 1159 | 791 | —Hyphen | xvi | —No. 54 | 42, 43, 67 |
| —Tendril | 794 | Leads and Slugs | 720 | —No. 56 | 44, 45, 68 |
| —Trinal | 377 | Lenten Initials | 793 | —No. 57 | 46, 47, 69 |
| —Two-Color | 790 | Lightface Celtic No. 150 | 435 | —No. 60 | 48-50, 70 |
| —Waverley | 792 | Light-Face No. 158 | 425 | —No. 61 | 51, 71 |
| —Wayside | 790 | Light Runic No. 110 | 434 | —No. 64 | 52, 53 |
| Ink Spots | 815 | Light Runic No. 152 | 434 | —No. 65 | 54, 55, 72 |
| Inland Series No. 56 | 44, 45, 68 | Lincoln | 382 | —No. 66 | 56, 73 |
| Inscription Greek | 682 | Lining Antique Nos. 40 to 45 | 561 | —No. 67 | 57-59, 74 |
| Interchangeable Gothic | 594 | Lining Gothic Extd. No. 40 | 590 | —No. 68 | 60, 75 |
| Ionic No. 30 | 549 | Lining Gothic No. 43 | 591 | Modern Text No. 2 | 669 |
| Ionic No. 120 | 546 | Lining Gothic No. 44 | 592 | Modern Text No. 40 | 642 |
| Ionic No. 122 | 546, 549, 696 | Lining Gothic No. 45 | 593 | Morning Glory | 429 |
| Ionic No. 150 | 547 | Lining Gothic Nos. 414 to | | Morris Initials | 791 |
| Ionic No. 159 | 549 | 417 | 591 | Mortised | 372 |
| Ipsen Borders | 757 | Lining Gothic Nos. 418 to | | Mortised Initials | 795 |
| Ipsen Initials | 794 | 422 | 592 | Multiform Nos. 1 to 4 | 454, 470 |
| Iroquois | 314, 315 | Lining Gothic Nos. 423 to | | Multiple Initials | 793 |
| Iroquois Condensed | 316, 317 | 427 | 593 | Munich | 426 |
| Isabella | 173 | Lining Roman No. 153 | 514, 515 | Mural | 390 |
| Ivanhoe | 176, 396 | Lippincott | 323 | Mural Ornaments | 768 |
| Jagged | 401 | Listeners | 812 | Music Type | 692-695 |
| Jefferson | 356 | Lithotint | 628 | Myrtle Borders | 760 |
| Jenson Embellishments | | Livermore | 251 | Neptune Initials | 793 |
| 788 ^r -788 ^h | | Livermore Outline | 459 | New Index Cuts | 872 |
| Jenson Heavyface | 276-279 | Locus Sigilli | 717 | New Metal Braces | 718 |
| Jenson Initials | 794 | LOGOTYPES: | | Newspaper Borders 734-738, 759 | |
| Jenson Italic | 250, 234-239 | —Billhead | 805 | Newspaper Headings: | |
| Jenson Old Style | 292-297 | —Commercial | 805 | —Brass | 804 ^r -804 ^l |
| Job Commercial Signs | 705 | —Mail List | 690 | —Electrotyped | 796-804 ^l |
| Johnson | 371 | —Special | 701 | Newspaper Sub-Headings: | |
| Johnston Gothic | 597 | —Time Table | 696 | —Brass | 804 ^r |
| Jupiter | 418 | Longfellow | 369 | —Electrotyped | 804 |
| Kate Greenaway Mig- | | Luray | 625 | Nic-Nacs | 774 |
| nonettes | 816, 817 | Madisonian | 213 | Nine Point Borders | 724 |
| Kitcat | 367 | Magnolia Script | 211 | Noname Initials | 793 |
| Klondike Borders | 765 | Mail List Logotypes | 690 | Nonpareil Borders | 722, 723 |
| Klondikers | 810 | Mail List Type | 691 | Nonpareil and One-Half | |
| Labor-Saving Brass | | Maltese Crosses | 715 | Borders | 724 |
| Leaders | 897 | Manila Border | 763 | Norman Condensed | 423 |
| Labor-saving Brass Rule 892, 893 | | Manuscript No. 1 and No. 2 | 212 | Norman Italic | 171 |
| | | Margin Ornaments | 768 | Novelty Script | 220 |
| | | Mathematical Signs | 698 | | |

| | PAGE |
|--------------------------------------|-------------------------------------|
| Obelisk | 397 |
| Octic Nos. 1 and 2 | 599 |
| Old Style Antique No. 40 | 510 |
| Old Style Antique No. 112 | 509 |
| Old Style Antique No. 120 | 510, 511 |
| Old Style Bold | 508 |
| Old Style Condensed No. 4 | 497 |
| Old Style Condensed No. 40 | 501 |
| Old Style Cond. No. 120 | 500 |
| Old Style Cond. No. 122 | 498, 499 |
| Old Style Extended | 507 |
| Old Style Italic No. 79 | 264, 265 |
| Old Style Latin Condensed | 395 |
| Old Style No. 43 | 502 |
| Old Style No. 83 | 491 ^e , 491 ^f |
| Old Style No. 83 Italic | 266, 267 |
| OLD STYLE ROMAN: | |
| —No. 71 | 104, 105 |
| —No. 72 | 101-103 |
| —No. 73 | 111 |
| —No. 77 | 106, 107 |
| —No. 79 | 108-110 |
| —No. 83 | 112, 113 |
| —No. 84 | 114, 115 |
| —No. 325 | 116, 117 |
| Old Style Script | 198 |
| Old Style Title | 512, 513 |
| Old Style Two-Line | 502 |
| Open Title No. 120 | 520 |
| ORNAMENTS: | |
| —Acanthine Florets | 779 |
| —Apple Blossom | 777 |
| —Card | 777 ^b |
| —Central | 775, 778 |
| —Christmas | 769 |
| —Classic | 769 |
| —Collins Florets | 780, 781 |
| —Combination, Series K | 776 |
| —Contour Palmetto | 775 |
| —Contour Pointers | 774 |
| —Dewey | 763 |
| —Dotlet | 771 |
| —Egyptian | 762 |
| —Electric | 771 |
| —Elzevir | 746, 747 |
| —Elzevir Florets | 755, 779 |
| —Empire | 785 |
| —Hapgood Florets | 778 ^f |
| —Happy Thoughts | 778 ^a |
| —Jenson Embellishments | 788 ^c -788 ^b |
| —Laurel | 767 |
| —Laurel Wreaths | 766 |
| —Margin | 768 |
| —Midget Tail Pieces | 762 |
| —Mural | 768 |
| —Palmetto | 775 |
| —Pin, Nail and Screw Heads | 774 |
| —Pointers | 774 |
| —“Post” | 786-788 ^d |
| —Printers’ Nic-Nacs | 774 |
| —Rogers Embellishments | 778 ^f |
| —Rule | 777 |
| —Schaeffer | 785 |
| —Scroll Corner | 777 |
| —Shaded Palmetto | 775 |

| | PAGE |
|--|-------------------------------------|
| ORNAMENTS—Continued | |
| —Shaded Pointers | 774 |
| —Stellar | 775 |
| —Turner | 775 |
| —Twinklers | 778 ^b |
| —Typographic Charms | 777 ^a |
| —Wayside | 782, 783 |
| —Wayside Embellishments | 784, 785 |
| Outing | 429 |
| OUTLINE TYPE: | |
| —Binner Open | 455 |
| —Bradley Italic Outline | 457 |
| —Bradley Outline | 456 |
| —Columbus Outline | 460, 461 |
| —Contour Nos. 1 to 7 | 472-477 |
| —Contour Bands and Borders | 750, 751, 753-756 |
| —Contour Palmetto Ornaments | 775 |
| —Contour Pointers | 774 |
| —De Vinne Italic Outline | 462, 463 |
| —De Vinne Shaded | 471 |
| —Epitaph Open | 469 |
| —Erratick Outline | 464 |
| —Figures | 871 |
| —Graphic | 477 |
| —Hades | 469 |
| —Howland Open | 466, 467 |
| —Laurel Borders | 752 |
| —Livermore Outline | 459 |
| —Multiform Nos. 2 to 4 | 470 |
| —Palo Alto | 478 |
| —Quaint Open | 468 |
| —Santa Cruz | 478 |
| —Satanick Open | 458 |
| —Virile Open | 465 |
| Ovals, Brass | 899 |
| Palm Border | 778 ^b |
| Palmetto Ornaments | 775 |
| Palo Alto | 478 |
| Parisian Black No. 120 | 632 |
| Parthenian | 491 ^g , 491 ^h |
| Pen Craft | 168 |
| Pen Text | 219 |
| Perforating Rule | 891 |
| Perpetual Calendar Logotypes | 712, 713 |
| Philadelphia Lining Gothic | 581-589 |
| Pica Borders | 724, 725, 739 |
| Pick-Ups | 811 |
| Piece Accents | xvi |
| Piece Fractions | 702, 703 |
| Piece Root Signs | 700 |
| Pin, Nail and Screw Heads | 774 |
| Point Combination Borders Series A and B | 778 ^d , 778 ^e |
| Pointers | 774 |
| Pointer Borders | 733 |
| Polka-Dot Border | 732 |
| Polo | 368 |
| Porson Greek | 678, 679 |
| “Post” Old Style Italic | 226-231 |
| “Post” Old Style Roman | 275 ^a -275 ^g |

| | PAGE |
|---|----------------------|
| “Post” Ornaments | 786-788 ^d |
| Primrose Borders | 759 |
| Printer’s Nic-Nacs | 774 |
| Priority Text | 638, 639 |
| Quads, Angular | 719 |
| —Circular | 719 |
| —Corner | 719 |
| Quaint | 359 |
| Quaint Open | 468 |
| Quaint Roman, No. 2 | 361 |
| Quentell | 308, 309 |
| Quentell Fractions | 309, 704 |
| Quincy Script | 218 |
| Quotation Furniture | 720 |
| Rabbinic | 677 |
| Ramona | 416 |
| Raphael | 629 |
| Recherche | 166 |
| Recipe Marks | 717 |
| Red, White and Blue Border | 754 |
| Regal Borders | 733 |
| Regal Italic | 258 |
| Remington Standard | 146 |
| Renate Initials | 793 |
| Revere Script | 197 |
| Reversible Metal Furniture | 720 |
| Rigs and Traps | 814 |
| Rimpled | 324, 325 |
| Rococo Border | 759 |
| Rogers Embellishments | 778 ^f |
| ROMAN AND ITALIC, MODERN: | |
| American Press Association No. 61 | 51, 71 |
| Century Roman | 61 |
| Century Roman No. 2 | 62 |
| Inland No. 56 | 44, 45, 68 |
| Large Face No. 54 | 42, 43, 67 |
| No. 17 | 6 |
| No. 18 | 6 |
| No. 44 | 514 |
| No. 46 | 34, 35, 63 |
| No. 47 | 36-38, 64 |
| No. 50 | 40, 41, 65 |
| No. 53 | 39, 66 |
| No. 57 | 46, 47, 69 |
| No. 64 | 52, 53 |
| No. 65 | 54, 55, 72 |
| No. 66 | 56, 73 |
| No. 67 | 57-59, 74 |
| No. 68 | 60, 75 |
| Self Spacing | 76, 128-135 |
| Wilson No. 60 | 48-50, 70 |
| ROMAN AND ITALIC, OLD STYLE: | |
| Binny O. S. No. 77 | 106, 107 |
| Caslon O. S. No. 71 | 104, 105 |
| Caxton | 118, 119 |
| Cushing | 124, 125 |
| Cushing Monotone | 126, 127 |
| Cushing Monotone No. 2 | 127 |
| Franklin O. S. No. 79 | 108-110 |
| French Elzevir No. 1 | 120, 121 |
| French O. S. No. 2 | 122, 123 |
| Old Style No. 73 | 111 |
| Old Style No. 83 | 112, 113 |
| Old Style No. 84 | 114, 115 |

| | PAGE | | PAGE | | PAGE |
|-----------------------------------|-------------------|-----------------------------------|---------------|-----------------------------------|------------------|
| ROMAN AND ITALIC, OLD | | SCRIPT TYPE— <i>Continued</i> | | Stylus | 161 |
| STYLE— <i>Continued</i> | | —Steelplate | 190, 191 | Stylus No 2 | 160 |
| Old Style No. 325 | 116, 117 | —Title | 199 | Superior Figures | 702 |
| Ronaldson O. S. No. 72 | 101-103 | —Vertical Writing | 206, 207 | Superior Letters | 702 |
| Self Spacing | 136-140 | Scroll Corner Ornaments | 777 | Take Slugs | 719 |
| Romanesque | 423 | Sectional Calendars | 711 | Taylor Gothic | 310 |
| Roman Extended No. 120 | 528 | Self Spacing German | 650 | Telescopic Gothic Nos. 155 | |
| Roman Fractions | 705 | Self Spacing Modern Ro- | | to 158 | 598 |
| Roman No. 44 | 514 | man and Italic | 76, 128-135 | Tendrils Initials | 794 |
| Roman Slope | 170 | Self Spacing Old Style Bold | 140 | Ten Point Typewriter No. 2 | 145 |
| Ronaldson | 101-103, 488, 490 | Self Spacing Old Style | | Teuton Black | 661 |
| Ronaldson Clarendon | 322 | Italic | 139, 156, 157 | Teutonic No. 1 | 668 |
| Ronaldson Condensed | 496 | Self Spacing Old Style | | Teutonic Extended | 672 |
| Ronaldson Extended | 506 | Roman and Italic | 128-135 | Thirty Point Border No. 1 | 759 |
| Ronaldson Gothic | 351 | Self Spacing Piece Frac- | | No. 102 | 726 |
| Ronaldson Title Slope | 248 | tions | 703 | Three-line Nonpareil Bor- | |
| Round Corner Rule | 880 | Self Spacing Signs | 129 | ders | 726 |
| Rounders | 815 | Shaded Palmetto Orna- | | Three-line Pica Borders | 726 |
| Round Gothic | 606 | ments | 775 | Three Point Borders | 721 |
| Roundhead | 366 | Shaded Pointers | 774 | Tiger Lily Border | 778 ^e |
| Royal Gothic | 607 | Shadow | 625 | Time-saving Mail List Type | 691 |
| Royal Script | 188, 189 | Shaved Leads and Slugs | 720 | Time-Table Figures | 696, 697 |
| Rubens | 364, 365 | Shepard Script | 216 | Time-Table Logotypes | 696 |
| Rule Ornaments | 777 | Shoppers | 813 | Tinted | 626 |
| Runic Condensed No. 120 | 433 | Signal Service Weather | | Title Black | 637 |
| Runic Condensed No. 122 | 432 | Signs | 714 | Title Expanded No. 120 | 529 |
| Russian No. 10 | 677 | Signal | 417 | Title Script | 199 |
| Rustic Band Border | 732 | SIGNS | 698-701 | Touraine O. S. Italic | 232, 233 |
| Sansom Script | 205 | —Algebraic | 698, 699 | Trinal | 377 |
| Santa Cruz | 478 | —Arithmetical | 698 | Trinal Initials | 377 |
| Satanick | 286-288 | —Astronomical | 699, 700 | Tristan Italic | 272 |
| Satanick Open | 458 | —Commercial | 698, 705 | Tudor Black | 630, 631 |
| Schœffer Old Style | 298-301 | —Ecclesiastical | 698 | Turner Ornaments | 775 |
| Schœffer Old Style Initials | 301 | —Mathematical | 698 | Twelve Point Borders | |
| Schœffer Ornaments | 785 | —Medical | 698 | | 724, 725, 739 |
| Schwabacher | 667 | —Miscellaneous | 700, 701 | Twelve Point Typewriter | 148 |
| Schwabacher No. 2 | 666 | —Piece Root | 700 | Twenty-four Point Borders | |
| Scorchers | 814 | —Self Spacing | 129 | | 726, 739 |
| Scoring Rules | 719, 891 | Silhouettes | 811 | Twinkler Borders | 778 ^e |
| Script No. 9 | 215 | Six Point Borders | 722, 723 | Twinklers | 778 ^b |
| SCRIPT TYPE: | | Six Point Braces and Dashes | | Two-color Borders | 753-756 |
| —American | 185-187 | No. 2 | 718 | Two-color Initials | 790 |
| —Autograph | 218 | Six Point Metal Braces | 718 | Two-color Type | 452-454 |
| —Boston | 192, 193 | Six Point Stars | 715 | Two-line Letter No. 35 | 523 |
| —Carpenter | 211 | Skinner Script | 213 | Two-line Letter No. 124 | 523 |
| —Chicago | 217 | Skjald | 380, 381 | Two-line Letter No. 128 | 521 |
| —Circular | 201 | Slocum Seals | 815 | Two-line Letter No. 129 | 523 |
| —Cleveland | 211 | Slugs, Labor-saving | 720 | Two-line Letter No. 151 | 521 |
| —Cursive | 214 | —Foot | 719 | Two-line Pica Borders | 726, 739 |
| —Devens | 208, 209 | Smith-Premier Typewriter | 146 | TYPEWRITER: | |
| —French | 202-204 | Space Rule | 891 | —American | 145 |
| —Gotham | 210 | Speaker Series | 812 | —Caligraph | 148 |
| —Herriet | 210 | Special Figures | 701 | —Earle | 147 |
| —Ladies' Hand | 200 | Special Fractions | 702 | —Fourteen Point No. 2 | 145 |
| —Madisonian | 213 | Special Logotypes | 701 | —Remington Standard | 146 |
| —Magnolia | 211 | Spencerian Script | 194, 195 | —Smith-Premier | 146 |
| —Manuscript | 212 | Spencerian Script No. 2 | 196 | —Standard | 145 |
| —No. 9 | 215 | Spinner Script | 217 | —Stenograf | 148 |
| —Novelty | 220 | Standard Lining Antique | 373 | —Ten Point No. 2 | 145 |
| —Old Style | 198 | Standard Typewriter | 145 | —Twelve Point | 148 |
| —Quincy | 218 | Star Rule | 902 | —Yost | 147 |
| —Revere | 197 | Stars | 715 | Typo | 379 |
| —Royal | 188, 189 | Steel Cutting Rules | 719 | Typographic Charms | 777 ^e |
| —Sansom | 205 | Steelplate Gothic | 626 | Typothetae | 381 |
| —Shepard | 216 | Steelplate Script | 190, 191 | Union Border | 755 |
| —Skinner | 213 | Steel Scoring Rule | 719 | Unique Celtic | 420 |
| —Spencerian | 194-196 | Stellar Ornaments | 775 | | |
| —Spinner | 217 | Stencil | 627 | | |
| | | Stenograf | 148 | | |

| | | | | | |
|-----------------------------------|-------------|------------------------------|-------------|-----------------------------|-------------|
| Unique Celtic Condensed | PAGE 421 | Walton | PAGE 388 | Whist Markers | PAGE 717 |
| University | 165 | Washington | 355 | Whiteface Figures | 697 |
| United States Signal Flags | 714 | Waverley Initials | 792 | Wilson Series No. 60 | 48-50, 70 |
| Venetian | 151 | Waverly Circular | 159 | Wood Borders | 903 |
| Vertical Writing | 206, 207 | Wayside Embellishments | | Wood Pointers | 902 |
| Victoria | 376 | Wayside Initials | 784, 785 | Wood Rule | 902 |
| Victoria Italic | 259 | Wayside Ornaments | 782, 783 | Wood Type | 901-924 |
| Virile | 358 | Weather Indicators | 714 | Yonkers | 636 |
| Virile Open | 465 | Webster | 419 | Yost Typewriter | 147 |

INDEX TO CUTS

| | | | | | |
|-------------------------------|----------------------|-------------------------------|--------------|--------------------------------|--------------|
| Animals | PAGE 849, 855-861 | Index Cuts | PAGE 872 | Society Emblems— <i>Cont'd</i> | PAGE |
| Army and Navy | 809 | Ink Spots | 815 | Foresters | 837 |
| Athletes | 815 | Kate Greenaway Mignon- | | Good Templars | 839 |
| Ballet Dancers | 812 | ettes | 816, 817 | Grand Army | 824 |
| Base Ball | 810 | Klondikers | 810 | Knights of Pythias | 835 |
| Beehives | 842 | Lady Speakers | 813 | K. of G. E. | 836 |
| Bells | 850 | Listeners | 812 | L. A. W. | 838 |
| Bicycles | 814, 854 | Locomotives | 864 | Masonic | 830-833 |
| Billhead Logotypes | 805 | Masquerade | 854 | Miscellaneous | 834-846 |
| Bill-of-Fare | 866, 867 | Menu Cuts | 866, 867 | National, Foreign | 844 |
| Blank Books | 869 | Newspaper | 876 | Odd Fellows | 833, 834 |
| Bowlers | 809 | Outline Figures | 871 | O. U. A. M. | 838 |
| Buffalo | 849 | Pickups | 811 | P. O. S. of A. | 841 |
| Business Cuts | 851-868 | Political Roosters | 862, 863 | Railroad Men | 842 |
| Campaigners | 812, 924 | Portraits | 825 | Red Men | 836 |
| Cattle | 860, 861 | Poultry | 862, 863 | Royal Arcanum | 838 |
| Check Blanks | 808 | Railroad | 864 | Salvation Army | 838 |
| Coats-of-Arms | 818, 819, 823 | Religious | 828, 829 | Sons of Veterans | 824 |
| Coppers | 811 | Rigs and Traps | 814 | Temperance | 839 |
| Crowns | 852 | Rounders | 815 | Temple of Honor | 840 |
| Delmonico Chefs and | | Scorchers | 814 | Speakers | 812 |
| Waiters | 810 | Shoppers | 813 | Sports | 852-854, 856 |
| Dentist | 853 | Silhouettes | 811 | Stars | 715, 870 |
| Domestics | 813 | Slocum Seals | 815 | State Seals | 818, 819 |
| Druggist | 811, 853 | Society Emblems | 823, 826-846 | Steamships | 865 |
| Eagles | 820, 821, 823 | American, Patriotic | 845, 846 | Tail Pieces | 874, 875 |
| Eye and Eye Glasses | 853 | A. O. U. W. | 837 | Trolley Cars | 858 |
| *Flags | 822, 823 | Catholic Societies | 843 | Typographical | 847 |
| Hoboes | 810 | Christian Endeavor | 826, 827 | U. S. Emblems | 820-822 |
| Horses | 855, 856, 876 | Epworth League | 826, 827 | Vehicles | 857, 858 |
| Index Corners | 873 | Firemen | 842 | Wine List | 866, 867 |
| | | | | World's Fair Medals | 848 |

* Old Glory Embossing Sets (page 822)—Set A, \$3.00; Set B, \$4.50; Set C, \$6.00

INDEX TO USEFUL INFORMATION

| | | | |
|--|-------------|--|--------------|
| Accents Used in Foreign Languages | PAGE xvi | Metric System of Weights and Measures | PAGE 1107 |
| American Point System | 1101 | Number of Ems in One Pound of Type | 1102 |
| Capacity of each box in type case—useful in | | Number of Ems in Square Inches of Type | 1102 |
| ordering sorts | 1103 | Number of Leads to the Pound | 1102 |
| Definitions of Signs | 698 | Number of Words in a Square Inch | 1103 |
| Directions for Securing Copyrights | 1104-1106 | Price List of Printing and Binding | 1117-1144 |
| How to Estimate | 1101 | Proofreaders' Marks | 1104 |
| How to Order Sorts | 1101, 1103 | Proportion of Type Bodies | 1101 |
| Imposition of Forms | 1108-1116 | Roman Numerals | 1102 |
| —Diagrams of Imposition | 1110-1116 | Sizes of Newspapers, Standard | 895 |
| —Gripper Margins | 1109 | Table for Newspaper Estimates | 895 |
| —Imposition of Cuts and Tables | 1109 | Table Showing Amount of Paper Required | 1104 |
| —Margins | 1108 | Table Showing Number of Staples to One | |
| —Press Points, uses of | 1109 | Pound of Wire | 1025 |
| —Testing Margins | 1109 | To Print Consecutive Numbers | 1103 |
| —Tests of Impositions | 1109 | Type Standards | 1101 |

INDEX TO MACHINERY AND MATERIALS

Printers' Wood Goods 931 to 973
 Printers' Machinery 974 to 1054
 Printers' Supplies 1055 to 1096

| | PAGE |
|---|------------|
| Acme Metal Extension Furniture | 1066 |
| Acme Staple Binders | 1026-1028 |
| Adamson Disk Cover | 1093 |
| Addressing Machines | 1050, 1051 |
| American Counter | 1003 |
| American Job Press Counter | 1002 |
| American Lead and Rule Cutters | 1052, 1053 |
| American-Polhemus Cabinets | 942, 943 |
| American Proof Press | 997 |
| American Steel-Run Cabinets | 946 |
| Army Press | 983 |
| Autocrat Case Stand | 939 |
| Automatic Numbering Machines | 1004-1008 |
| Beating Tables | 961 |
| Bellows | 1060 |
| Belting | 993 |
| Bentrovato | 1090 |
| Benzine Cans | 1069, 1070 |
| —Poole's | 1070 |
| —Success Safety | 1069 |
| —Truxell | 1069 |
| —Union Safe | 1069 |
| —Union Storage | 1069 |
| Blankets, Felt and Rubber | 1070 |
| Bodkins | 1055 |
| Bone Folders | 1061 |
| Bookbinders' Cabinet | 951 |
| Bookbinders' Case | 951 |
| Bookbinders' Job Backer | 1031 |
| Bookbinders' Press Boards | 970 |
| Bookbinders' Standing Presses | 1045 |
| Bookbinders' Table Shears | 1017 |
| Bookbinders' Wire | 1023, 1025 |
| Book Sewing Machine, Tennis | 1021 |
| Book Stabber | 1035 |
| Border and Script-Type Cabinets | 949 |
| Boston Lead Rack | 960 |
| Boxwood | 1061 |
| Brackets | 1059 |
| Brass-Bound Press Boards | 970 |
| Brass Galleys | 1072-1075 |
| Brass Label Holder | 1058 |
| Brass Rule Curving Machines | 1054 |
| Brayers | 1086 |
| Bronze Powders | 1096 |
| Bronzing Mitten | 1093 |
| Bronzing Pad | 1093 |
| Brower Quoins | 1064 |
| Brower Quoin-Lock | 1065 |
| Brushes, Benzine | 1071 |
| —Cement | 1071 |
| —Lye | 1071 |
| —Padding Glue | 1071 |
| —Proof | 1071 |
| —Stereotype Beating | 1071 |
| Burbank's Embossing Composition | 1092 |
| Cabinets | |
| —American-Polhemus | 942, 943 |
| —American Steel-Run | 946 |
| —Blank Case | 953 |
| —Bookbinders' | 951 |

| | PAGE |
|--|------------|
| Cabinets—Continued | |
| —Border and Script Type | 949 |
| —Cut | 952, 953 |
| —Electro and Cut | 953 |
| —Galley | 955 |
| —Handy Letter Board | 954 |
| —Handy Sort | 950 |
| —Indexed Electrotype | 952, 953 |
| —Ink and Roller | 954 |
| —Linotype Matrix | 956 |
| —Paper and Card Stock | 950 |
| —Porter's Extension Front, Steel-Run | 948 |
| —Rowen Border and Script | 949 |
| —Sort | 950 |
| —Specimen | 956 |
| —Steel-Run American-Polhemus | 943 |
| —Wisconsin Hard Wood | 945 |
| —Wisconsin Steel-Run | 947 |
| —Wisconsin Window | 944 |
| —Wood Type | 951 |
| Card Cutters | 1015, 1016 |
| Cases | 932-938 |
| —Bookbinders' | 951 |
| —California Job | 936 |
| —Combination Quarter | 935 |
| —Compact Rule | 934 |
| —Double Lower | 936 |
| —Full-size | 932 |
| —Harris Rule | 933, 934 |
| —Improved Job | 936 |
| —Individual Lead or Rule | 935 |
| —Mammoth Wood Type | 937 |
| —Metal Furniture | 937 |
| —New York Job | 936 |
| —Patent Clasp | 932, 933 |
| —Paterson Job | 936 |
| —Rooker | 933, 936 |
| —Rule | 933-935 |
| —Sanspareil Rule | 933 |
| —Script or Wood Type | 937 |
| —Space and Quad | 937 |
| —Special | 933 |
| —Three-quarter | 932 |
| —Two-third | 933 |
| —Wells' Two-Font Job | 938 |
| —Yankee Job | 937 |
| Case Racks | 939, 941 |
| Case Stands, Wood | 939, 941 |
| Case Stands, Wrought Iron | 966 |
| Cement Brush | 1071 |
| Challenge Country Cylinder Press | 982 |
| Challenge Proof Press | 997 |
| Chases | 1080-1085 |
| —Book or Shifting Bar | 1082 |
| —Cast Iron | 1084 |
| —Electrotype | 1084 |
| —For Job Presses | 1085 |
| —Heading, with Cross-bar | 1084 |
| —Newspaper, Folio | 1080 |
| —Newspaper, Quarto | 1081 |
| —Poster | 1083 |
| —Quadruple | 1081 |
| —Spider, for Job Presses | 1085 |

| | | | |
|---|------------|--|-----------|
| Chases— <i>Continued</i> | PAGE | | PAGE |
| —Stereotype | 1085 | Felt Blankets | 1070 |
| —Twin | 1080 | Folders, Bone and Steel | 1061 |
| —Twin, with Bars | 1081 | Folders | 994-996 |
| —Wrought Iron, for Job Presses | 1085 | —Bennet Country Quarto | 996 |
| Chesapeake Economy Compound | 1091 | —Bennet Economical | 996 |
| Combination Paper Jogger | 992 | —Tribune Newspaper | 994, 995 |
| Combination Shuteboard and Type-High Machine | 1049 | —Unique Iron Frame | 995 |
| Compact Rule Case | 934 | Foot Sticks | 1084 |
| Composing Rules | 1055 | Form Truck | 1085 |
| Composing Stick Rack | 1058 | Furniture, Labor-saving Wood | 958, 959 |
| Composing Sticks | 1056, 1057 | —Metal | 720 |
| —American Job | 1057 | —Quotation | 720 |
| —Buckeye | 1056 | —Reversible Metal | 720 |
| —Common Screw | 1056 | —Wood | 958, 959 |
| —“C” Slot | 1056 | Galley Brackets | 957 |
| —Grover | 1056 | Galley Cabinets | 955 |
| —Perfect News | 1057 | Galley Lock-up | 1074 |
| —Wooden Poster | 1057 | Galley Proof Presses | 997, 998 |
| —Yankee Job | 1056 | Galley Racks | 957 |
| Cone Pulleys | 993 | Galleys | 1072-1075 |
| Copper Thin Spaces | 1060 | —All-Brass | 1073 |
| Copy Holder, Kelsey | 1058 | —Closed-end Mailing | 1072 |
| Counters | 1002, 1003 | —Lincoln | 1075 |
| —American | 1003 | —Linotype | 1074 |
| —American Job Press | 1002 | —Mailing | 1073 |
| —Double Dial Alarm | 1003 | —Plate Zinc Storage | 1075 |
| —Durant | 1003 | —Smooth Lined | 1072 |
| Countershafts | 993 | —Success Riveted, all Brass | 1073 |
| Cranston Cylinder Presses | 984-989 | —Unlined | 1072 |
| Curving Machines, Rule | 1054 | —With Lockup | 1074 |
| Cut Cabinets | 952, 953 | —Wooden | 1073 |
| Cutting and Creasing Press, Gally Universal | 980 | Gally Universal Presses | 975-978 |
| Cutting Boards | 970 | Gauge Pin Drawer | 1062 |
| Cutting Sticks and Strips | 971 | Gauge Pins and Guides | 1062 |
| Diagonal-Grain Cutting Boards | 970 | Gloss Varnishes | 1096 |
| Dillingham Press Punch | 1063 | Glue Pot | 1089 |
| Disk Cover, Adamson | 1093 | Gold Leaf Lettering and Stamping Press | 1044 |
| Dividers | 1060 | Gordon Presses | 974, 982 |
| Double Case Brackets | 1059 | Gripper Perforator, Miller's | 1068 |
| Double-Dial Alarm Counter | 1003 | Guides for Platen Presses | 1062 |
| Dryers | 1096 | Hack Saws | 1060 |
| Drying Racks | 968, 969 | Hamilton Patent Cutting Stick | 971 |
| —Chicago | 968 | Hand Perforator | 1043 |
| —Køerner's Interlocking | 969 | Hand Rollers | 1086 |
| —Movable | 968 | Hand Press, Washington | 1001 |
| —New York | 968 | Hand Stabbing Machines | 1035 |
| Durant Counter | 1003 | Handy Letter Board Cabinets | 954 |
| Economic Proof Press | 997 | Handy Sort Cabinet | 950 |
| Elastic Padding Glue | 1089 | Handy Sort Drawers | 950 |
| Electricity Dissipater | 1090 | Hangers | 993 |
| Electro and Cut Cabinet | 952, 953 | Harris Rule Cases | 934 |
| Elite Rule Bender | 1054 | Hempel Quoins | 1064 |
| Embossing Composition | 1092 | Herald Success Self-Inking Proof Press | 999 |
| Embossing Compound | 1092 | Hercules Liquid Overlay | 1090 |
| Embossing, Guide to | 1092 | Ideal Hand Cylinder Press | 1000 |
| Embossing Presses | 979, 1044 | Ideal Inking Apparatus | 1000 |
| End-Wood Cutting Boards | 970 | Illustrations of Cases | 936, 937 |
| Engravers' Tools | 1061 | Imposing Surfaces, Iron | 963 |
| Engravers' Wood | 1061 | Imposing Tables and Stones | 962, 963 |
| Eureka Lead Rack | 960 | Indexed Electrotypes Cabinet | 952, 953 |
| Eureka Type Wash | 1091 | Indexing Machines | 1030 |
| Extension Front Cabinets | 948 | Individual Lead or Rule Case | 935 |
| Eyeletting Machines | 1037-1039 | Inks | 1094-1096 |
| Eyelet Punch and Set | 1037 | Ink and Roller Cabinet | 954 |
| Eyelets | 1038 | Ink Fountains | 974, 982 |
| Eye Shade | 1057 | —Buckeye | 974 |
| | | —Chandler & Price | 974 |
| | | (See also under respective Presses.) | |

| | PAGE | | PAGE |
|--|------------|---|-----------------|
| Ink Knives | 1061 | Monitor Table Shears | 1017 |
| Inkoleum | 1090 | Morton Lock-up | 1066 |
| Ink Reducers | 1090, 1091 | Multiplex Punching Machines | 1034, 1036 |
| Ink Slabs, Marble | 963 | Narrow Margin Brass Register Hooks | 1078 |
| Ink Slice | 1061 | Neverslip Quoin | 1067 |
| Ink Spade | 1061 | Newspaper File | 972 |
| Iron-bound Mallets | 931 | Newspaper Folder, Tribune | 994 |
| Iron Case Stands | 966 | New York Space-saving Case Stands | 941 |
| Iron Imposing Surfaces | 963 | Numbering Machines | 1004-1008 |
| Iron Side and Foot Sticks | 1084 | —Bates' Automatic | 1008 |
| Iron-top Beating Tables | 961 | —Monitor | 1007 |
| Interlocking Drying Racks, Kœrner's | 969 | —Paragon | 1008 |
| Job Backer | 1031 | —Wetter | 1004-1007 |
| Kelsey Copy Holder | 1058 | Overhead Power Fixtures | 992, 993 |
| Keystone Hack Saw | 1060 | Overlay Knife | 1061 |
| Knives | 1061, 1089 | Overlay, Liquid | 1090 |
| Label Holder | 1058 | Padding Glue, Elastic | 1089 |
| Labor-saving Furniture, Wood | 958, 959 | Padding Glue, Liquid | 1089 |
| Lamp Holder | 1059 | Paging and Numbering Machine | 1007 |
| Lead and Rule Cutters | 1052, 1053 | Pallet Ink Knives | 1061 |
| —American | 1052, 1053 | Paper and Card Stock Cabinet | 950 |
| —Chandler & Price | 1053 | Paper Box Cutting and Creasing Press | 980 |
| —Handy | 1053 | Paper Counter | 1089 |
| —Utility | 1053 | Paper Cutters | 1009-1015 |
| Leader and Sort Box | 1075 | —Advance Lever | 1012 |
| Leader Box | 935, 1075 | —Advance Power | 1014 |
| Lead or Rule Case | 935 | —Challenge Lever | 1009 |
| Lead Racks | 960 | —Challenge Pony Lever | 1012 |
| Leather Belting | 993 | —Challenge Power | 1015 |
| Letter Board Cabinets | 954 | —Chandler & Price | 1009 |
| Letter Boards | 954 | —Clipper | 1013 |
| Linotype Galley | 1074 | —Peerless Gem | 1010, 1011 |
| Linotype Matrix Cabinet | 956 | —Reliance Lever | 1012 |
| Linotype Planer | 931 | —Utility | 1013 |
| Liquid Cement Brush | 1071 | Paper Folders, Bone and Steel | 1061 |
| Liquid Overlay | 1090 | Paper Jogger | 992 |
| Liquid Padding Glue | 1089 | Paper Knife | 1061 |
| Long Wood Quoins | 973 | Patent Cutting Stick | 971 |
| Lye Brushes | 1071 | Patent Tilting Case Bracket | 944 |
| Magnifying Glass | 1061 | Peerless Job Press | 981 |
| Mailing Galley | 1050 | Perfection Wire Stitchers | 1022-1024 |
| Mailing Machines | 1050, 1051 | Perforators | 1040-1043, 1068 |
| —Acme | 1051 | —Franklin Hand | 1043 |
| —Horton | 1050 | —Gem | 1041 |
| —McFatrach | 1051 | —Miller Perfect Gripper | 1068 |
| —Mustang | 1050 | —Monitor Extra Heavy Round Hole, Power | 1040 |
| Make-up Rules | 1055 | —Monitor Round Hole, Foot-power | 1041 |
| Make-up Tables | 961 | —Printers' | 1068 |
| Mallets, Iron Bound | 931 | —Progress Extra Heavy | 1042 |
| —Patent Rawhide | 931 | —Rosback Foot-power | 1042 |
| —Wooden | 931 | —Rosback Hand | 1043 |
| Maple Blocks | 972 | —Rosback Power | 1042 |
| Marble Stones | 962, 963 | Pilot Hand Lever Press | 982 |
| May's Patented Leader and Sort Box | 1075 | Planers | 931 |
| Metallic Tape Couplers | 1071 | Pliers | 1071 |
| Midget Safety Quoin | 1065 | Power Fixtures | 992, 993 |
| Miter Boxes | 1060 | Press Boards | 970 |
| Mitering Machines | 1054 | —Bookbinders' | 970 |
| Monitor Automatic Wire Stitchers | 1018-1021 | —Brass-Bound | 970 |
| Monitor Job Backer | 1031 | —Tympan | 1070 |
| Monitor Paging and Numbering Machine | 1007 | Press Guides | 1062 |
| Monitor Punching and Round Corner Cutting Machine | 1031 | Press Points | 1063 |
| Monitor Round Corner, Punching and Index Cutting Machine | 1030 | Press Punches | 1063 |
| | | Printers' Brushes | 1071 |
| | | Printers' Dividers | 1060 |
| | | Printers' Eye Shade | 1057 |
| | | Printers' Perforator and Scorer | 1068 |

| | PAGE | | PAGE |
|---|------------------------------|---|---------------|
| Printers' Saw Table | 1048, 1049 | Standing Galleys, Wrought Iron | 967 |
| Printers' Trucks | 1067 | Standing Presses | 1045 |
| Printing Inks | 1094-1096 | Stands | 939, 941, 966 |
| Printing Presses: | | Staple Binders | 1026-1029 |
| —Army | 983 | —Acme | 1026-1028 |
| —Challenge Country Cylinder | 982 | —Breech Loader | 1029 |
| —Challenge Gordon | 982 | —Hercules | 1029 |
| —Chandler & Price Gordon | 974 | —Sure Shot No. 1 | 1028 |
| —Cottrell Monarch Two-Roller | 991 | —Other Staple Binders | 1029 |
| —Cottrell Triumph Country | 990 | Staples, Wire | 1027, 1029 |
| —Cranston Improved Book and News | 985 | Stars for Fly Sticks | 1061 |
| —Cranston Improved Newspaper | 985 | Steel-Run American-Polhemus Cabinets | 942, 943 |
| —Cranston Improved Two-Roller | 986 | Stereotype Blocks | 1076-1078 |
| —Cranston Newspaper | 984 | Sterling Round-Cornering Machine | 1032 |
| —Cranston-Victor Commercial | 987 | Stitching Machines | 1018-1024 |
| —Cranston-Victor Two-Revolution | 988, 989 | Success Card Cutter | 1016 |
| —Gally Universal | 975-978 | Success Self-Inking Proof Press | 998, 999 |
| —Ideal Hand Cylinder | 1000 | Success Wire Stitcher | 1024 |
| —Peerless | 981 | Table Shears, Monitor | 1017 |
| —Pilot Hand Lever | 982 | Tablet Knife | 1089 |
| —Washington Hand | 1001 | Tablet Presses | 1088 |
| Progress Foot-power Round-Cornering and Punching Machine | 1033 | Tape | 1070 |
| Proof Planers | 931 | Tape Couplers | 1071 |
| Proof Presses | 997, 998 | Tape Fastener | 1070 |
| Proof Rollers | 1086 | Tennis Book Sewing Machine | 1021 |
| Punching Machines | 1030, 1033, 1034, 1036, 1037 | Tie-up, Vierling | 1079 |
| Pulleys | 993 | Tilting Case Brackets | 944, 1059 |
| Quoin Lock | 1065 | Tint Blocks | 972 |
| Quoins | 1064-1067 | Trucks | 1067 |
| —Mechanical | 1064-1067 | Tweezers | 1055 |
| —Well's Long Wood | 973 | Tympan Press Boards | 1070 |
| —Wooden | 973 | Type-high Gauge | 1059 |
| Rawhide Mallets | 931 | Type-high Machine | 1048, 1049 |
| Reducing Glass | 1061 | Type Measures | 1058 |
| Reducing Varnishes | 1096 | Type Wash, Eureka | 1091 |
| Register Hooks | 1078 | Typographic Numbering Machines | 1004-1008 |
| Reglet Cases, Labor-saving | 958 | Union Lockable Quoin | 1065 |
| Reglet, Labor-saving | 958 | Universal Embossing Press | 979 |
| Roller Cloth | 1070 | Universal Paper Box Cutting and Creasing Press | 980 |
| Roller Composition | 1087 | Universal Presses | 975-978 |
| Roller Composition Kettle | 1087 | Universal Sawing Machine | 1048 |
| Roller Supporters | 1087 | Universal Stamping Press | 979 |
| Rollers | 1086 | Varnishes | 1096 |
| Roll-Front Case Racks | 939 | Vierling Patent Tie-up | 1079 |
| Round-Corner Cutting Machines | 1030-1033 | Washington Hand Press | 1001 |
| Rubber Blankets | 1070 | Web Success Self-Inking Proof Press | 998 |
| Rule Bender | 1054 | Wetter Numbering Machines | 1004-1007 |
| Rule Cases | 933-935 | Whiteson's Embossing Composition | 1092 |
| Rule Curving Machine | 1054 | Wickersham Quoins | 1066 |
| Rule Cutters | 1052, 1053 | Wire, on Spools | 1023, 1025 |
| Ruling Machines | 1046, 1047 | Wire Staples | 1027, 1029 |
| Ruling Pens | 1047 | Wire Stitchers | 1018, 1024 |
| Sawing Machine | 1048, 1049 | Wisconsin Combination Quarter Cases | 935 |
| Saws | 1048, 1049, 1060 | Wisconsin Hard-Wood Cabinets | 945 |
| Saw Table, Printers' | 1048, 1049 | Wisconsin Lead Rack | 960 |
| Script-Type Cabinet | 949 | Wisconsin Steel-Run Cabinets | 947 |
| Self-Inking Proof Presses | 998, 999 | Wisconsin Window Cabinet | 944 |
| Shafting | 993 | Wrapper Paster, Economy | 1051 |
| Shooting Sticks | 1060 | Wood Circles | 972 |
| Shute Board and Type-high Machine | 1049 | Wooden Galleys | 1073 |
| Side Sticks | 958, 1084 | Wooden Mallets | 931 |
| Sort Drawers, Handy | 950 | Wooden Quoins | 973 |
| Specimen Cabinets | 956 | Wooden Shooting Sticks | 1060 |
| Stabbing Machine, Hand | 1035 | Wood Furniture | 958, 959 |
| Stamping Press, Gally Universal | 979 | Wood-Type Cabinets | 951 |
| Standing Galleys, Wood, etc. | 964, 965 | Wood-Type Case Rack | 941, 951 |

PRICE LIST OF JOB TYPE

SUBJECT TO DISCOUNT

| POINT BODIES | Second-Class Type in fonts of 25 lbs. and over | Second-Class Special Type in fonts of 25 lbs. and over | Third-Class Type Scripts, Patented Letters, etc. 25 lbs. and over |
|--------------------|--|--|---|
| 4½ Point | Per lb. \$2 50 | Per lb. \$2 80 | Per lb. \$3 20 |
| 5 " | 1 80 | 2 00 | 2 80 |
| 5½ " | 1 44 | 1 60 | 2 40 |
| 6 " | 1 16 | 1 28 | 2 00 |
| 7 " | 1 00 | 1 12 | 1 80 |
| 8 " | 0 90 | 1 00 | 1 60 |
| 9 " | 0 80 | 0 90 | 1 44 |
| 10 " | 0 74 | 0 82 | 1 30 |
| 11 " | 0 70 | 0 78 | 1 22 |
| 12 " | 0 66 | 0 74 | 1 16 |
| 14 " | 0 62 | 0 70 | 1 12 |
| 15 " | 0 62 | 0 70 | 1 08 |
| 16 " | 0 60 | 0 70 | 1 06 |
| 18 " | 0 60 | 0 66 | 1 00 |
| 20 " | 0 60 | 0 66 | 0 94 |
| 22 " | 0 56 | 0 64 | 0 90 |
| 24 " | 0 56 | 0 64 | 0 90 |
| 28 " | 0 56 | 0 64 | 0 86 |
| 30 " | 0 56 | 0 62 | 0 84 |
| 32 " | 0 56 | 0 62 | 0 82 |
| 36 " | 0 56 | 0 62 | 0 82 |
| 40 " | 50 lbs. and over \$0 54 | 50 lbs. and over \$0 60 | 50 lbs. and over \$0 78 |
| 42 " | 0 54 | 0 60 | 0 72 |
| 44 " | 0 54 | 0 60 | 0 72 |
| 48 " | 0 54 | 0 60 | 0 72 |
| 54 " | Sold in Fonts only | Sold in Fonts only | Sold in Fonts only |
| 60 " | | | |
| 72 " | | | |
| 84 " | | | |
| 96 " | | | |
| 120 " | | | |

ALLOWANCE FOR OLD TYPE AND OTHER METALS

Old type (clean and unmixed with other metals), electrotypes, leads and brass, delivered at foundry free, will be taken at current prices in even exchange for new type or printing material.

Customers sending in old metal are requested to mark their names on all packages, and to forward by mail a shipping receipt or bill of lading, with the net weight of each kind of material, as soon as shipment is made. Compliance with this request will aid in identifying shipments, and prevent errors. Ship as "old metal" to secure low freight rate.

SPECIAL NOTICE.—Zinc plates, metal containing zinc, or type and other plates mixed with zinc plates, and stereotype plates, will not be received at any price. Type, electrotype plates, leads and brass, must be packed separately, as the value of each differs.

PRICE LIST OF BODY TYPE

SUBJECT TO DISCOUNT

| POINT BODIES. | 25 LBS. | 500 LBS. | 1000 LBS. |
|---------------------------------------|-------------|--------------|-----------|
| | TO 500 LBS. | TO 1000 LBS. | AND OVER. |
| | Per lb. | Per lb. | Per lb. |
| 3½ Point | \$5 00 | \$4 75 | \$4 50 |
| 3½ " on 4½-Point | 3 50 | 3 40 | 3 30 |
| 4½ " | 1 60 | 1 55 | 1 50 |
| 5 " | 1 20 | 1 15 | 1 10 |
| 5½ " | 0 74 | 0 72 | 0 71 |
| 6 " | 0 64 | 0 62 | 0 61 |
| 7 " | 0 56 | 0 54 | 0 53 |
| 8 " | 0 52 | 0 50 | 0 49 |
| 9 " | 0 48 | 0 46 | 0 45 |
| 10 " | 0 46 | 0 44 | 0 43 |
| 11 " | 0 44 | 0 42 | 0 41 |
| 12 " | 0 42 | 0 40 | 0 40 |
| 14 " | 0 40 | 0 40 | 0 40 |
| 15 " | 0 40 | 0 40 | 0 40 |
| 16 " | 0 40 | 0 40 | 0 40 |
| Above 16 Point at Second-class Prices | | | |

Roman and German Body Type is put up in fonts of 25, 50 and 100 pounds, or some multiple of these weights. Included in each 25 pounds are 5 pounds of Spaces and Quads, and same proportions in larger fonts.

Italic and Accents will not be sent with Roman fonts unless specially ordered. Smallest font of Italic furnished weighs 5 pounds. A pair of full-size cases holds 50 pounds of body type.

SPACES AND QUADS IN JOB FONTS

Spaces and Quads are put up in Job Fonts at the following prices:

| | Per Font | | Per Font |
|-------------------|----------|--------------------|----------|
| 5 Point | \$1 40 | 24 Point | \$0 60 |
| 5½ " | 1 00 | 28 " | 0 55 |
| 6 " | 0 65 | 30 " | 0 50 |
| 7 " | 0 65 | 32 " | 0 50 |
| 8 " | 0 65 | 36 " | 0 55 |
| 9 " | 0 60 | 40 " | 0 60 |
| 10 " | 0 55 | 42 " | 0 60 |
| 11 " | 0 60 | 44 " | 0 60 |
| 12 " | 0 60 | 48 " | 0 80 |
| 14 " | 0 60 | 54 " | 1 10 |
| 15 " | 0 60 | 60 " | 1 15 |
| 16 " | 0 55 | 72 " | 1 25 |
| 18 " | 0 55 | 84 " | 0 90 |
| 20 " | 0 60 | 96 " | 1 70 |
| 22 " | 0 50 | 120 " | 1 40 |

Spaces and Quads are also put up in assorted fonts of five pounds, at Body Type Prices.

ACCENTED LETTERS

We make a vast number of accented letters for both body and job type for use in the Spanish, French, German, Swedish, Norwegian, Danish, Italian, Portuguese, Polish and Bohemian languages. We print below assortments of accents used in various languages for the information of our customers, who will be informed upon application as to which of these accents can be supplied for any size or series of type. Accents not in common use in this country will be cut to order at a special price.

The following lower case accented letters of Roman and Italic are furnished with the body type for which they are made, and a number of these accented letters can also be furnished in capitals and small capitals.

| | | | |
|-----------------------|-------------------------|-----------------------|------------------------|
| Acute . . . á é í ó ú | Circumflex â ê î ô û | Long . . . ā ē ī ō ū | Spanish (Nya) . . . ñ |
| Grave . . . à è ì ò ù | Diaeresis . . ä ë ï ö ü | Short . . . ă ę ı ǒ ǔ | French (Cedilla) . . ç |

ACCENTED LETTERS USED IN VARIOUS MODERN LANGUAGES

| | |
|-------------------------------|---------------------|
| BOHEMIAN | ITALIAN |
| Á Ć Ď É Ě Í Ń Ó Ŕ Š Ť Ů Ú Ý Ž | À È Ì Ò Ù à è ì ò ù |
| á ě ě í ń ó ř š ť ú ů ý ž | POLISH |
| DANISH AND NORWEGIAN | Ą Ć Ę Ł Ó Ś Ź Ż |
| Ø ø | ą ć ę ł ó ś ź ż |
| FRENCH | PORTUGUESE |
| É À È Ù Â Ê Î Ô Û Ç | Á É Í Ó Ú Ñ Ç Ü Ã Õ |
| é à è ù â ê î ô û ç ï ë ü | á é í ó ú ñ ç ü ã õ |
| GERMAN | SPANISH |
| Ä Ö Ü ä ö ü | Á É Í Ó Ú Ñ Ü |
| HUNGARIAN | á é í ó ú ñ ü |
| Á É Í Ó Ú Ö Ü Ő Ű | SWEDISH |
| á é í ó ú ö ü ő ű | Å Ä Ö å ä ö |

PIECE ACCENTS

| | | | |
|----------------------------|-----------------|-----------------------|--------|
| 12 POINT No 6 [®] | PER FONT \$1 50 | 6 POINT No 150 | \$0 50 |
| | | | |
| 12 POINT [®] | PER FONT \$1 50 | 4 POINT No 150 | \$0 40 |
| | | | |
| 9 POINT [®] | PER FONT \$1 10 | 3 POINT No 150 | \$0 30 |
| | | | |
| | | 6 POINT SHADED No 150 | \$0 25 |
| | | | |

LEADERS FOR BODY TYPE

| | |
|--|--|
| STYLE 1 (REGULAR) TWO DOTS TO EM | STYLE 3 (WIDE DOT) ONE DOT TO EM |
| STYLE 2 (CLOSE DOT) THREE DOTS TO EM | STYLE 5 (WIDE HYPHEN) TWO STROKES TO EM ----- |
| STYLE 4* (FINE-DOT HYPHEN) FOUR STROKES TO EM ----- | |

Can furnish these styles for most of our body letter. When ordering, state the type (if our make) they are required to line with, and send sample cap "H" or lower-case "m."

*Style 4 is also shown on page 271 under the name of Copper-Alloy Fine-Dot Leaders.

PART I.

BODY TYPE

Shown by Sizes and in Series

RANGING FROM

3½ Point to 14 Point

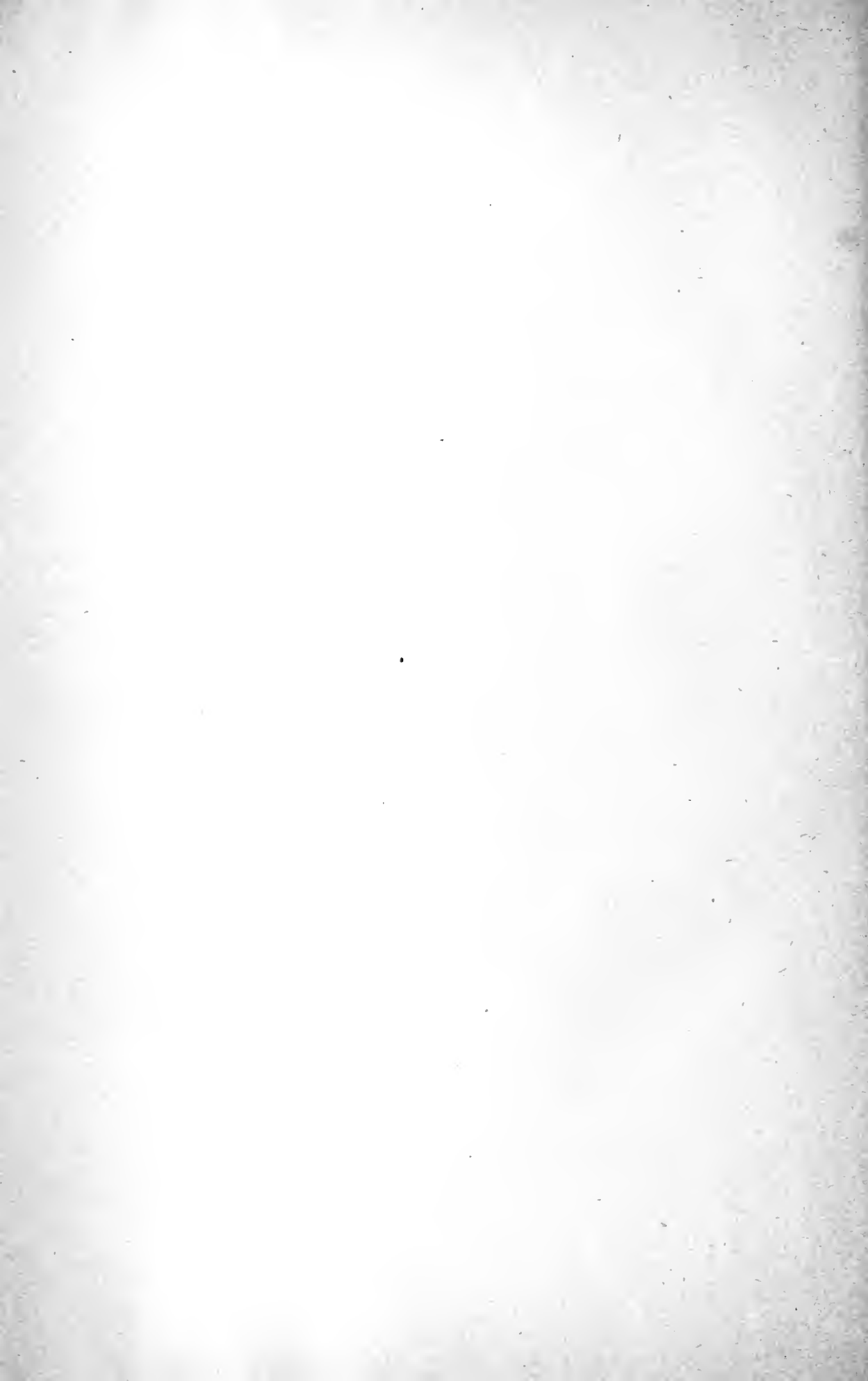

SYNOPSIS OF ROMAN BODY TYPE

All sizes are spaced uniformly with 3-to-em spaces

Series No.

3½ POINT MODERN ROMAN

17—When, in the course of human events, it becomes necessary for one people to dissolve the political bands which have connected them with another, and to assume, among

4½ POINT MODERN ROMAN

18—When, in the course of human events, it becomes necessary for one people to dissolve the political bands which have connected them with another, and to assum

17—When, in the course of human events, it becomes necessary for one people to dissolve the political bands which have connected them with another

5 POINT MODERN ROMAN

67—When, in the course of human events, it becomes necessary for one people to dissolve the political bands which have cot

57—When, in the course of human events, it becomes necessary for one people to dissolve the political ba

46—When, in the course of human events, it becomes necessary for one people to dissolve the politicr

5 POINT OLD STYLE ROMAN

79—When, in the course of human events, it becomes necessary for one people to dissolve the political bands which have 1

5½ POINT MODERN ROMAN

66—When, in the course of human events, it becomes necessary for one people to dissolve the political band.

67—When, in the course of human events, it becomes necessary for one people to dissolve the political bans

47—When, in the course of human events, it becomes necessary for one people to dissolve the political bat

65—When, in the course of human events, it becomes necessary for one people to dissolve the political bel

53—When, in the course of human events, it becomes necessary for one people to dissolve the political

46—When, in the course of human events, it becomes necessary for one people to dissolve the politicon

57—When, in the course of human events, it becomes necessary for one people to dissolve the politica

19½—When, in the course of human events, it becomes necessary for one people to dissolve the pol

56—When, in the course of human events, it becomes necessary for one people to dissolve the p

5½ POINT OLD STYLE ROMAN

80—When, in the course of human events, it becomes necessary for one people to dissolve the political bw

73—When, in the course of human events, it becomes necessary for one people to dissolve the politica

6 POINT MODERN ROMAN

65—When, in the course of human events, it becomes necessary for one people to dissolve the politisi

66—When, in the course of human events, it becomes necessary for one people to dissolve the pos

36½—When, in the course of human events, it becomes necessary for one people to dissolve the pol

20½—When, in the course of human events, it becomes necessary for one people to dissolve the pol

54—When, in the course of human events, it becomes necessary for one people to dissolve the pol

47—When, in the course of human events, it becomes necessary for one people to dissolve the pol

60—When, in the course of human events, it becomes necessary for one people to dissolve the po

67—When, in the course of human events, it becomes necessary for one people to dissolve the po

53—When, in the course of human events, it becomes necessary for one people to dissolve the e

57—When, in the course of human events, it becomes necessary for one people to dissolve then

50—When, in the course of human events, it becomes necessary for one people to dissolve thes

46—When, in the course of human events, it becomes necessary for one people to dissolve ths

61—When, in the course of human events, it becomes necessary for one people to dissolve tei

37½—When, in the course of human events, it becomes necessary for one people to dissolve

68—When, in the course of human events, it becomes necessary for one people to dissolit

56—When, in the course of human events, it becomes necessary for one people to disssw

6 POINT OLD STYLE ROMAN

71—When, in the course of human events, it becomes necessary for one people to dissolve the political bands w

79—When, in the course of human events, it becomes necessary for one people to dissolve the political ban

*—When, in the course of human events, it becomes necessary for one people to dissolve the political b

||—When, in the course of human events, it becomes necessary for one people to dissolve the politicah

84—When, in the course of human events, it becomes necessary for one people to dissolve the policif

77—When, in the course of human events, it becomes necessary for one people to dissolve the polil

30—When, in the course of human events, it becomes necessary for one people to dissolve the pol

83—When, in the course of human events, it becomes necessary for one people to dissolve the ps

72—When, in the course of human events, it becomes necessary for one people to dissolve the s

325—When, in the course of human events, it becomes necessary for one people to dissolve its

73—When, in the course of human events, it becomes necessary for one people to dissolves

27—When, in the course of human events, it becomes necessary for one people to dissolvi

xx—When, in the course of human events, it becomes necessary for one people to d

* French Old Style No. 2

|| Cushing

xx Caxton Old Style

SYNOPSIS OF ROMAN BODY TYPE—*Continued**All sizes are spaced uniformly with 3-to-em spaces*

7 POINT MODERN ROMAN

Series No.

- 65—When, in the course of human events, it becomes necessary for one people to dissolve this
 66—When, in the course of human events, it becomes necessary for one people to dissolve t
 23½—When, in the course of human events, it becomes necessary for one people to dissolve
 47—When, in the course of human events, it becomes necessary for one people to dissolvn
 60—When, in the course of human events, it becomes necessary for one people to dissolvl
 67—When, in the course of human events, it becomes necessary for one people to disso
 54—When, in the course of human events, it becomes necessary for one people to disso
 57—When, in the course of human events, it becomes necessary for one people to dissr
 50—When, in the course of human events, it becomes necessary for one people to diss
 53—When, in the course of human events, it becomes necessary for one people to disi
 61—When, in the course of human events, it becomes necessary for one people to de
 68—When, in the course of human events, it becomes necessary for one people to ir
 38½—When, in the course of human events, it becomes necessary for one people too
 46—When, in the course of human events, it becomes necessary for one people to s
 56—When, in the course of human events, it becomes necessary for one peopleo

7 POINT OLD STYLE ROMAN

- 79—When, in the course of human events, it becomes necessary for one people to dissolve the poli
 83—When, in the course of human events, it becomes necessary for one people to dissolvei
 84—When, in the course of human events, it becomes necessary for one people to dissolvn
 *—When, in the course of human events, it becomes necessary for one people to disso
 77—When, in the course of human events, it becomes necessary for one people to dissw
 72—When, in the course of human events, it becomes necessary for one people to dissol
 73—When, in the course of human events, it becomes necessary for one people to dissa
 325—When, in the course of human events, it becomes necessary for one people to dip

8 POINT MODERN ROMAN

- ¶—When, in the course of human events, it becomes necessary for one people to dissolve i
 64—When, in the course of human events, it becomes necessary for one people to din
 60—When, in the course of human events, it becomes necessary for one people to di
 65—When, in the course of human events, it becomes necessary for one people to r
 47—When, in the course of human events, it becomes necessary for one people to s
 18½—When, in the course of human events, it becomes necessary for one people tol
 34½—When, in the course of human events, it becomes necessary for one people tol
 67—When, in the course of human events, it becomes necessary for one people ts
 66—When, in the course of human events, it becomes necessary for one people il
 57—When, in the course of human events, it becomes necessary for one people t
 54—When, in the course of human events, it becomes necessary for one people t
 61—When, in the course of human events, it becomes necessary for one people t
 50—When, in the course of human events, it becomes necessary for one peoplei
 53—When, in the course of human events, it becomes necessary for one peopli
 68—When, in the course of human events, it becomes necessary for one peoli
 46—When, in the course of human events, it becomes necessary for one pes
 48½—When, in the course of human events, it becomes necessary for one pe
 56—When, in the course of human events, it becomes necessary for one p

8 POINT OLD STYLE ROMAN

- 71—When, in the course of human events, it becomes necessary for one people to dissolve the polita
 †—When, in the course of human events, it becomes necessary for one people to dissw
 ‡—When, in the course of human events, it becomes necessary for one people to dissn
 79—When, in the course of human events, it becomes necessary for one people to disst

* French Old Style No. 2

† French Elzevir No. 1

¶ Century Roman

‡ Cushing Monotone

SYNOPSIS OF ROMAN BODY TYPE—*Continued**All sizes are spaced uniformly with 3-to-em spaces*8 POINT OLD STYLE ROMAN—*Continued*

Series No.

- ||—When, in the course of human events, it becomes necessary for one people to dise
 *—When, in the course of human events, it becomes necessary for one people to k
 22—When, in the course of human events, it becomes necessary for one people tw
 72—When, in the course of human events, it becomes necessary for one people tn
 77—When, in the course of human events, it becomes necessary for one people ts
 83—When, in the course of human events, it becomes necessary for one peoplee
 84—When, in the course of human events, it becomes necessary for one peoplet
 325—When, in the course of human events, it becomes necessary for one peoplw
 xx—When, in the course of human events, it becomes necessary for oa

9 POINT MODERN ROMAN

- ¶—When, in the course of human events, it becomes necessary for one people tij
 67—When, in the course of human events, it becomes necessary for one people o
 65—When, in the course of human events, it becomes necessary for one peoples
 60—When, in the course of human events, it becomes necessary for one peoplw
 54—When, in the course of human events, it becomes necessary for one peos
 53—When, in the course of human events, it becomes necessary for one peoc
 47—When, in the course of human events, it becomes necessary for one peo
 64—When, in the course of human events, it becomes necessary for one pey
 57—When, in the course of human events, it becomes necessary for one pn
 32½—When, in the course of human events, it becomes necessary for one pe
 50—When, in the course of human events, it becomes necessary for one
 61—When, in the course of human events, it becomes necessary for ond
 56—When, in the course of human events, it becomes necessary for it
 46—When, in the course of human events, it becomes necessary fort

9 POINT OLD STYLE ROMAN

- 71—When, in the course of human events, it becomes necessary for one people to dil
 79—When, in the course of human events, it becomes necessary for one peoplw
 77—When, in the course of human events, it becomes necessary for one pws
 28—When, in the course of human events, it becomes necessary for one pe
 72—When, in the course of human events, it becomes necessary for one pa
 83—When, in the course of human events, it becomes necessary for one po
 325—When, in the course of human events, it becomes necessary for onff

10 POINT MODERN ROMAN

- ¶—When, in the course of human events, it becomes necessary for one pr
 65—When, in the course of human events, it becomes necessary for one c
 †—When, in the course of human events, it becomes necessary for one t
 67—When, in the course of human events, it becomes necessary for one l
 54—When, in the course of human events, it becomes necessary for onis
 60—When, in the course of human events, it becomes necessary for one
 64—When, in the course of human events, it becomes necessary for il
 57—When, in the course of human events, it becomes necessary for g
 47—When, in the course of human events, it becomes necessary for o

SYNOPSIS OF ROMAN BODY TYPE—*Continued**All sizes are spaced uniformly with 3-to-em spaces*10 POINT MODERN ROMAN—*Continued*

Series No.

- 17½—When, in the course of human events, it becomes necessary fo
 50—When, in the course of human events, it becomes necessary fs
 56—When, in the course of human events, it becomes necessary fi

10 POINT OLD STYLE ROMAN

- 71—When, in the course of human events, it becomes necessary for one people d
 ¶—When, in the course of human events, it becomes necessary for one pes
 †—When, in the course of human events, it becomes necessary for one pe
 29—When, in the course of human events, it becomes necessary for one pe
 79—When, in the course of human events, it becomes necessary for one w
 §—When, in the course of human events, it becomes necessary for ones
 77—When, in the course of human events, it becomes necessary for onet
 84—When, in the course of human events, it becomes necessary for ort
 *—When, in the course of human events, it becomes necessary for os
 72—When, in the course of human events, it becomes necessary for os
 83—When, in the course of human events, it becomes necessary foo
 24—When, in the course of human events, it becomes necessary fo
 325—When, in the course of human events, it becomes necessary fo
 x—When, in the course of human events, it becomes necessary fo
 xx—When, in the course of human events, it becomes necessit

11 POINT MODERN ROMAN

- 60—When, in the course of human events, it becomes necessary for on
 67—When, in the course of human events, it becomes necessary forn
 54—When, in the course of human events, it becomes necessary fort
 65—When, in the course of human events, it becomes necessary foit
 47—When, in the course of human events, it becomes necessae
 64—When, in the course of human events, it becomes necesb
 21½—When, in the course of human events, it becomes necei

11 POINT OLD STYLE ROMAN

- 71—When, in the course of human events, it becomes necessary for onk
 §—When, in the course of human events, it becomes necessary forn
 79—When, in the course of human events, it becomes necessary fow
 25—When, in the course of human events, it becomes necessary so
 84—When, in the course of human events, it becomes necessary fir
 72—When, in the course of human events, it becomes necessary tu
 77—When, in the course of human events, it becomes necessarys
 325—When, in the course of human events, it becomes neceset
 83—When, in the course of human events, it becomes necesi

¶ Cushing

* French Old Style No. 2

† French Elzevir No. 1

x Cushing Monotone No. 2

§ Cushing Monotone

xx Caxton Old Style

SYNOPSIS OF ROMAN BODY TYPE—*Continued**All sizes are spaced uniformly with 3-to-em spaces*

12 POINT MODERN ROMAN

Series No.

- 60—When, in the course of human events, it becomes necessar
 67—When, in the course of human events, it becomes necesn
 54—When, in the course of human events, it becomes neceh
 31½—When, in the course of human events, it becomes nech
 64—When, in the course of human events, it becomes nit
 47—When, in the course of human events, it becomes ns

12 POINT OLD STYLE ROMAN

- 71—When, in the course of human events, it becomes necessak
 84—When, in the course of human events, it becomes necessa
 †—When, in the course of human events, it becomes necesst
 ||—When, in the course of human events, it becomes neceso
 79—When, in the course of human events, it becomes necess
 77—When, in the course of human events, it becomes necess
 72—When, in the course of human events, it becomes necesi
 26—When, in the course of human events, it becomes neca
 *—When, in the course of human events, it becomes ness
 83—When, in the course of human events, it becomesr
 325—When, in the course of human events, it becomir
 xx—When, in the course of human events, it becomes

14 POINT MODERN ROMAN

- 64—When, in the course of human events, it becomes x
 60—When, in the course of human events, it becomes

14 POINT OLD STYLE ROMAN

- 71—When, in the course of human events, it becomes w
 79—When, in the course of human events, it becomes
 †—When, in the course of human events, it become

15 POINT OLD STYLE ROMAN

- 72—When, in the course of human events, it becs

18 POINT MODERN ROMAN

- 67—When, in the course of human events, t

† French Elzevir No. 1
 || Cushing

* French Old Style No. 2
 XX Caxton Old Style

MODERN ROMANS SHOWN BY SIZES

Same faces shown by series on pages 34 to 62

3½ POINT NO 17 °

Card Font, Roman, \$10 00
Card Font, Italic, \$10 00

When, in the course of human events, it becomes necessary for one people to dissolve the political bands which have connected them with another, and to assume, among the powers of the earth, the separate and equal station to which the laws of nature and of nature's God entitle them, a decent respect to the opinions of mankind requires that they should declare the causes which impel them to the separation. We hold these truths to be self-evident, that all men are created equal; that they are endowed by their Creator with certain unalienable rights; that among these, are life, liberty, and the pursuit of happiness. That, to secure these rights, governments are instituted among men, deriving their just powers from the consent of the governed; that, whenever any form of government becomes destructive of these ends, it is the right of the people to alter or to abolish it, and to institute a new government, laying its foundation on such principles, and organizing its powers in such form, as to them shall seem most likely to effect their safety and happiness. Prudence, indeed, will dictate that governments long established, should not be changed for light and transient causes; and, accordingly, all experience hath shown, that mankind are more disposed to suffer, while evils are sufferable, than to right themselves by abolishing the forms to which they are accustomed. But, when a long train of abuses and usurpations, pursuing invariably the same object, evinces a design to reduce them to absolute despotism, it is their right, it is their duty, to throw off such government, and to provide new guards for their future security. Such has been the patient sufferance of these colonies, and such is now the necessity which constrains them to alter their former systems of government. *The history of the present king of Great Britain is a history of repeated injuries and usurpations, all having, in direct object,*

ABCDEFGHIJKLMNOPQRSTUVWXYZ

1234567890

4½ POINT NO 17 °

Card Font, Roman, \$7 50
Card Font, Italic, \$7 50

WHEN, in the course of human events, it becomes necessary for one people to dissolve the political bands which have connected them with another, and to assume, among the powers of the earth, the separate and equal station to which the laws of nature and of nature's God entitle them, a decent respect to the opinions of mankind requires that they should declare the causes which impel them to the separation. We hold these truths to be self-evident, that all men are created equal; that they are endowed by their Creator with certain unalienable rights; that among these, are life, liberty, and the pursuit of happiness. That, to secure these rights, governments are instituted among men, deriving their just powers from the consent of the governed; that, whenever any form of government becomes destructive of these ends, it is the right of the people to alter or to abolish it, and to institute a new government, laying its foundation on such principles, and organizing its powers in such form, as to them shall seem most likely to effect their safety and happiness. Prudence, indeed, will dictate that governments long established, should not be changed for light and transient causes; and, accordingly, all experience hath shown, that mankind are more disposed to suffer, while

ABCDEFGHIJKLMNOPQRSTUVWXYZ

1234567890

5 POINT NO 57 °

WHEN, in the course of human events, it becomes necessary for one people to dissolve the political bands which have connected them with another, and to assume, among the powers of the earth, the separate and equal station to which the laws of nature and of nature's God entitle them, a decent respect to the opinions of mankind requires that they should declare the causes which impel them to the separation. We hold these truths to be self-evident, that all men are created equal; that they are endowed by their Creator with certain unalienable rights; that among these, are life, liberty, and the pursuit of happiness. That, to secure these rights, governments are instituted among men, deriving their just powers from the consent of the governed; that, whenever any form of government becomes destructive of these ends, it is the right of the people to

Lower case a to z, 17 ems

ABCDEFGHIJKLMNOPQRSTUVWXYZ

1234567890

4½ POINT NO 18 °

Card Font, Roman, \$10 50
Card Font, Italic, \$10 50

When, in the course of human events, it becomes necessary for one people to dissolve the political bands which have connected them with another, and to assume, among the powers of the earth, the separate and equal station to which the laws of nature and of nature's God entitle them, a decent respect to the opinions of mankind requires that they should declare the causes which impel them to the separation. We hold these truths to be self-evident, that all men are created equal; that they are endowed by their Creator with certain unalienable rights; that among these, are life, liberty, and the pursuit of happiness. That, to secure these rights, governments are instituted among men, deriving their just powers from the consent of the governed; that, whenever any form of government becomes destructive of these ends, it is the right of the people to alter or to abolish it, and to institute a new government, laying its foundation on such principles, and organizing its powers in such form, as to them shall seem most likely to effect their safety and happiness. Prudence, indeed, will dictate that governments long established, should not be changed for light and transient causes; and, accordingly, all experience hath shown, that mankind are more disposed to suffer, while evils are sufferable, than to right themselves by abolishing the forms to which they are accustomed. But, when a long train of abuses and usurpations,

ABCDEFGHIJKLMNOPQRSTUVWXYZ

1234567890

5 POINT NO 67 °

Card Font, Roman, \$10 80

WHEN, in the course of human events, it becomes necessary for one people to dissolve the political bands which have connected them with another, and to assume, among the powers of the earth, the separate and equal station to which the laws of nature and of nature's God entitle them, a decent respect to the opinions of mankind requires that they should declare the causes which impel them to the separation. We hold these truths to be self-evident, that all men are created equal; that they are endowed by their Creator with certain unalienable rights; that among these, are life, liberty, and the pursuit of happiness. That, to secure these rights, governments are instituted among men, deriving their just powers from the consent of the governed; that, whenever any form of government becomes destructive of these ends, it is the right of the people to alter or to abolish it, and to institute a new government, laying its foundation on such principles,

Lower case a to z, 14½ ems

ABCDEFGHIJKLMNOPQRSTUVWXYZ

1234567890

5 POINT NO 46 °

WHEN, in the course of human events, it becomes necessary for one people to dissolve the political bands which have united them with another, and to assume, among the powers of the earth, the separate and equal station to which the laws of nature and of nature's God entitle them, a decent respect to the opinions of mankind requires that they should declare the causes which impel them to the separation. We hold these truths to be self-evident, that all men are created equal; that they are endowed by their Creator with certain unalienable rights; that among these, are life, liberty, and the pursuit of happiness. That, to secure these rights, governments are instituted among men, deriving their just powers from the consent of the governed; that, whenever any form of government becomes destructive of these ends, it is the

Lower case a to z, 17 ems

ABCDEFGHIJKLMNOPQRSTUVWXYZ

1234567890

5½ POINT NO 47 F

WHEN, in the course of human events, it becomes necessary for one people to dissolve the political bands which have connected them with another, and to assume, among the powers of the earth, the separate and equal station to which the laws of nature and of nature's God entitle them, a decent respect to the opinions of mankind requires that they should declare the causes which impel them to the separation. We hold these truths to be self-evident, that all men are created equal; that they are endowed by their Creator with certain unalienable rights; that among these, are life, liberty, and the pursuit of

Lower case a to z, 15 ems

ABCDEFGHIJKLMN OPQRSTUVWXYZ
1234567890

E 5½ POINT NO 66

WHEN, in the course of human events, it becomes necessary for one people to dissolve the political bands which have connected them with another, and to assume, among the powers of the earth, the separate and equal station to which the laws of nature and of nature's God entitle them, a decent respect to the opinions of mankind requires that they should declare the causes which impel them to the separation. We hold these truths to be self-evident, that all men are created equal; that they are endowed by their Creator with certain unalienable rights; that among these, are life, liberty, and the pursuit of

Lower case a to z, 15 ems

ABCDEFGHIJKLMN OPQRSTUVWXYZ
1234567890

5½ POINT NO 67 E

WHEN, in the course of human events, it becomes necessary for one people to dissolve the political bands which have connected them with another, and to assume, among the powers of the earth, the separate and equal station to which the laws of nature and of nature's God entitle them, a decent respect to the opinions of mankind requires that they should declare the causes which impel them to the separation. We hold these truths to be self-evident, that all men are created equal; that they are endowed by their Creator with certain unalienable rights; that among these, are life, liberty, and the pursuit of happiness. That, to secure these rights, governments are instituted among men, deriving their just powers from the consent of the governed; that, whenever any form of government becomes destructive of these ends, it is the right of the people to alter or to abolish it, and to institute a new government, laying its foundation on such principles, and organizing its powers in such form, as to them shall seem most likely to effect their safety and happiness. Prudence, indeed, will dictate that governments long established, should not be changed for light and transient causes; and, accordingly, all experience hath shown, that mankind are more disposed to suffer, while evils are sufferable, than to right them-

Lower case a to z, 15½ ems

ABCDEFGHIJKLMN OPQRSTUVWXYZ
1234567890

5½ POINT NO 65 E

WHEN, in the course of human events, it becomes necessary for one people to dissolve the political bands which have connected them with another, and to assume, among the powers of the earth, the separate and equal station to which the laws of nature and of nature's God entitle them, a decent respect to the opinions of mankind requires that they should declare the causes which impel them to the separation. We hold these truths to be self-evident, that all men are created equal; that they are endowed by their Creator with certain unalienable rights; that among these, are life, liberty, and the pursuit of happiness. That, to secure these rights, governments are instituted among men, deriving their just powers from the consent of the governed; that, whenever any form of government becomes destructive of these ends, it is the right of the people to alter or to abolish it, and to institute a new government, laying its foundation on such principles, and organizing its powers in such form, as to them shall seem most likely to effect their safety and happiness. Prudence, indeed, will dictate that governments long established, should not be changed for light and transient causes; and, accordingly, all experience hath shown, that mankind are more disposed to suffer

Lower case a to z, 15¾ ems

ABCDEFGHIJKLMN OPQRSTUVWXYZ
1234567890

5½ POINT NO 53 E

WHEN, in the course of human events, it becomes necessary for one people to dissolve the political bands which have connected them with another, and to assume among the powers of the earth, the separate and equal station to which the laws of nature and of nature's God entitle them, a decent respect to the opinions of mankind requires that they should declare the causes which impel them to the separation. We hold these truths to be self-evident, that all men are created equal; that they are endowed by their Creator with certain unalienable rights; that among these, are life, liberty, and the pursuit of happiness. That, to secure these rights, governments are instituted among men, deriving their just powers from the consent of the governed; that whenever any government becomes destructive of these ends, it is the right of the people to alter or to abolish it, and to institute a new government, laying its foundation on such principles, and organizing its powers in such form, as to them shall seem most likely to effect their safety and happiness. Prudence, indeed, will dictate that governments long established, should not be changed for light and transient causes; and, accordingly, all experience hath shown, that mankind are more disposed to suffer, while

Lower case a to z, 16¼ ems

ABCDEFGHIJKLMN OPQRSTUVWXYZ
1234567890

5½ POINT NO 46 ^f

WHEN, in the course of human events, it becomes necessary for one people to dissolve the political bands which have connected them with another, and to assume, among the powers of the earth, the separate and equal station to which the laws of nature and of nature's God entitle them, a decent respect to the opinions of mankind requires that they should declare the causes which impel them to the separation. We hold these truths to be self-evident, that all men are created equal; that they are endowed by their Creator with certain unalienable rights; that among these, are life, liberty, and the pursuit of happiness. That, to secure these rights, governments are instituted among men, deriving their just powers from the consent of the governed; that, whenever any form of government becomes destructive of these ends, it is the right of the people to alter or to abolish it, and to institute a new government, laying its foundation on such principles, and organizing its powers in such form, as to them shall seem most likely to effect their safety and happiness. Prudence, indeed, will dictate that governments long established, should not be changed for *light and transient causes; and, accordingly, all experience hath shown, that mankind are*

Lower case a to z, 16 ems

ABCDEFGHIJKLMNOPQRSTUVWXYZ
1234567890

5½ POINT NO 57 ^e

WHEN, in the course of human events, it becomes necessary for one people to dissolve the political bands which have connected them with another, and to assume, among the powers of the earth, the separate and equal station to which the laws of nature and of nature's God entitle them, a decent respect to the opinions of mankind requires that they should declare the causes which impel them to the separation. We hold these truths to be self-evident, that all men are created equal; that they are endowed by their Creator with certain unalienable rights; that among these, are life, liberty, and the pursuit of happiness. That, to secure *these rights, governments are instituted among men, deriving their just powers from the consent of the governed; that, whenever any government becomes destructive of these ends, it is the right of the people to alter or to abolish it, and to institute a new government, laying its foundation on such principles, and organizing its powers in such form, as to them shall seem most likely to effect their safety and happiness. Prudence, indeed, will dictate that governments long established, should not be changed for light and transient causes; and, accordingly, all experience hath shown, that mankind*

Lower case a to z, 16 ems

ABCDEFGHIJKLMNOPQRSTUVWXYZ
1234567890

5½ POINT SELF SPACING NO 19½ ^b

Unit of measure, 12 to Pica

WHEN, in the course of human events, it becomes necessary for one people to dissolve the political bands which have connected them with another, and to assume, among the powers of the earth, the separate and equal station to which the laws of nature and of nature's God entitle them, a decent respect to the opinions of mankind requires that they should declare the causes which impel them to the separation. We hold these truths to be self-evident, that all men are created equal; that they are endowed by their Creator with certain unalienable rights; that among these, are life, liberty, and the pursuit of happiness. That, to secure these rights, governments are instituted among men, deriving their just powers from the consent of the governed; that, whenever any form of government becomes destructive of these ends, it is the right of the people to alter or to abolish it, and to institute a new government, laying its foundation on such principles, and organizing its powers in such form, as to them shall seem most likely to effect their safety and happiness. Prudence, indeed, will *dictate that governments long established, should not be changed for light and tran-*

Lower case a to z, 16½ ems

ABCDEFGHIJKLMNOPQRSTUVWXYZ
1234567890

5½ POINT NO 56 ^d

WHEN, in the course of human events, it becomes necessary for one people to dissolve the political bands which have connected them with another, and to assume, among the powers of the earth, the separate and equal station to which the laws of nature and of nature's God entitle them, a decent respect to the opinions of mankind requires that they should declare the causes which impel them to the separation. We hold these truths to be self-evident, that all men are created equal; that they are endowed by their Creator with certain unalienable rights; that among these, are life, liberty, and the pursuit of happiness. That, to secure these rights, governments are instituted among men, deriving their just powers from the consent of the governed; that, whenever any form of government becomes destructive of these ends, it is the right of the people to alter or to abolish it, and to institute a new government, laying its foundation on such principles, and organizing its powers in such form, as to them shall seem most likely to effect their safety and happiness. Prudence, indeed, will *dictate that governments long established, should not be changed for light and transient*

Lower case a to z, 17½ ems

ABCDEFGHIJKLMNOPQRSTUVWXYZ
1234567890

6 POINT No 65

E

WHEN, in the course of human events, it becomes necessary for one people to dissolve the political bands which have connected them with another, and to assume, among the powers of the earth, the separate and equal station to which the laws of nature and of nature's God entitle them, a decent respect to the opinions of mankind requires that they should declare the causes which impel them to the separation. We hold these truths to be self-evident, that all men are created equal; that they are endowed by their Creator with certain unalienable rights; that among these, are life, liberty, and the pursuit of happiness. That, to secure these rights, governments are instituted among men, deriving their just powers from the consent of the governed; that, whenever any form of government becomes destructive of these ends, it is the right of the people to alter or to abolish it, and to institute a new government, laying its foundation on such principles, and organizing its powers in such form, as to them shall seem most likely to effect their safety and happiness. *Prudence, indeed, will dictate that governments long established,*

Lower case a to z, 15 ems

ABCDEFGHIJKLMNPOQRSTUVWXYZ

1234567890

6 POINT No 66

E

WHEN, in the course of human events, it becomes necessary for one people to dissolve the political bands which have connected them with another, and to assume, among the powers of the earth, the separate and equal station to which the laws of nature and of nature's God entitle them, a decent respect to the opinions of mankind requires that they should declare the causes which impel them to the separation. We hold these truths to be self-evident, that all men are created equal; that they are endowed by their Creator with *certain unalienable rights; that among these, are* life, liberty, and the pursuit of happiness. That, to secure these rights, governments are instituted among men, deriving their just powers from the consent of the governed; that, whenever any government becomes destructive of these ends, it is the right of the people to alter or to abolish it, and to institute a new government, laying its foundation on such principles, and organizing its powers in such form, as to them shall seem most likely to effect their safety and happiness. *Prudence, indeed, will dictate that governments*

Lower case a to z, 15 ems

ABCDEFGHIJKLMNPOQRSTUVWXYZ

1234567890

6 POINT No 67

E

WHEN, in the course of human events, it becomes necessary for one people to dissolve the political bands which have connected them with another, and to assume, among the powers of the earth, the separate and equal station to which the laws of nature and of nature's God entitle them, a decent respect to the opinions of mankind requires that they should declare the causes which impel them to the separation. We hold these truths to be self-evident, that all men are created equal; that they are endowed by their Creator with certain unalienable rights; that among these, are life, liberty, and the pursuit of happiness. That to secure these rights, governments are instituted among men, deriving their just powers from the consent of the governed; that, whenever any form of government becomes destructive of these ends, it is the right of the people to alter or to abolish it, and to institute a new government, laying its foundation on such principles, and organizing its powers in such form, as to them shall seem most likely to effect their safety and happiness. *Prudence, indeed, will dictate that govern-*

Lower case a to z, 15½ ems

ABCDEFGHIJKLMNPOQRSTUVWXYZ

1234567890

6 POINT No 47

F

WHEN, in the course of human events, it becomes necessary for one people to dissolve the political bands which have connected them with another, and to assume, among the powers of the earth, the separate and equal station to which the laws of nature and of nature's God entitle them, a decent respect to the opinions of mankind requires that they should declare the causes which impel them to the separation. We hold these truths to be self-evident, that all men are created equal; that they are endowed by their Creator with certain unalienable rights; that among these, are life, liberty, and the pursuit of happiness. That, to secure these rights, governments are instituted among men, deriving their just powers from the consent of the governed; that, whenever any form of government becomes destructive of these ends, it is the right of the people to alter or to abolish it, and to institute a new government, laying its foundation on such principles, and organizing its powers in such form, as to them shall seem most likely to effect their safety and happiness. *Prudence, indeed, will dictate that gov-*

Lower case a to z, 15½ ems

ABCDEFGHIJKLMNPOQRSTUVWXYZ

1234567890

6 POINT NO 54 ^c

WHEN, in the course of human events, it becomes necessary for one people to dissolve the political bands which have connected them with another, and to assume, among the powers of the earth, the separate and equal station to which the laws of nature and of nature's God entitle them, a decent respect to the opinions of mankind requires that they should declare the causes which impel them to the separation. We hold these truths to be self-evident, that all men are created equal; that they are endowed by their Creator with certain unalienable rights: that among these, are life, liberty, and the pursuit of happiness. That, to secure these rights, governments are instituted among men, deriving their just powers from the consent of the governed; that, whenever any form of government becomes destructive of these ends, it is the right of the people to alter or to abolish it, and to institute a new government, laying its foundation on such principles, and organizing its powers in such form, as to them *shall seem most likely to effect their safety and happiness. Prudence, indeed, will dictate that*

Lower case a to z, 15 $\frac{3}{4}$ ems

ABCDEFGHIJKLMN OPQRSTUVWXYZ
1234567890

6 POINT NO 60 ^A

WHEN, in the course of human events, it becomes necessary for one people to dissolve the political bands which have connected them with another, and to assume, among the powers of the earth, the separate and equal station to which the laws of nature and of nature's God entitle them, a decent respect to the opinions of mankind requires that they should declare the causes which impel them to the separation. We hold these truths to be self-evident, that all men are created equal; that they are endowed by their Creator with certain unalienable rights; that among these, are life, liberty, and the pursuit of happiness. That, to secure these rights, governments are instituted among men, deriving their just powers from the consent of the governed; that, whenever any form of government becomes destructive of these ends, it is the right of the people to alter or to abolish it, and to institute a new government, laying its foundation on such principles, and organizing its powers in such form, as *shall seem most likely to effect their safety and happiness. Prudence, indeed, will dic-*

Lower case a to z, 15 $\frac{1}{2}$ ems

ABCDEFGHIJKLMN OPQRSTUVWXYZ
1234567890

6 POINT SELF SPACING NO 20 $\frac{1}{2}$ ^B

Unit of measure, 12 to Pica

WHEN, in the course of human events, it becomes necessary for one people to dissolve the political bands which have connected them with another, and to assume, among the powers of the earth, the separate and equal station to which the laws of nature and of nature's God entitle them, a decent respect to the opinions of mankind requires that they should declare the causes which impel them to the separation. We hold these truths to be self-evident, that all men are created equal; that they are endowed by their Creator with certain unalienable rights; that among these, are life, liberty, and the pursuit of happiness. That, to secure these rights, governments are instituted among men, deriving their just powers from the consent of the governed; that, whenever any form of government becomes destructive of these ends, it is the right of the people to alter or to abolish it, and to institute a new government, laying its foundation on such principles, and organizing its powers in such form, as to them *shall seem most likely to effect their safety and happiness. Prudence, indeed, will*

Lower case a to z, 15 $\frac{1}{2}$ ems

ABCDEFGHIJKLMN OPQRSTUVWXYZ
1234567890

6 POINT SELF SPACING NO 36 $\frac{1}{2}$ ^B

Unit of measure, 12 to Pica

WHEN, in the course of human events, it becomes necessary for one people to dissolve the political bands which have connected them with another, and to assume, among the powers of the earth, the separate and equal station to which the laws of nature and of nature's God entitle them, a decent respect to the opinions of mankind requires that they should declare the causes which impel them to the separation. We hold these truths to be self-evident, that all men are created equal; that they are endowed by their Creator with certain unalienable rights; that among these, are life, liberty, and the pursuit of happiness. That, to secure these rights, governments are instituted among men, deriving their just powers from the consent of the governed; that, whenever any form of government becomes destructive of these ends, it is the right of the people to alter or to abolish it, and to institute a new government, laying its foundation on such principles, and organizing its powers in such form, as to them *shall seem most likely to effect their safety and happiness. Prudence, indeed, will*

Lower case a to z, 15 $\frac{1}{2}$ ems

ABCDEFGHIJKLMN OPQRSTUVWXYZ
1234567890

6 POINT NO 53 ^E

WHEN, in the course of human events, it becomes necessary for one people to dissolve the political bands which have connected them with another, and to assume, among the powers of the earth, the separate and equal station to which the laws of nature and of nature's God entitle them, a decent respect to the opinions of mankind requires that they should declare the causes which impel them to the separation. We hold these truths to be self-evident, that all men are created equal; that they are endowed by their Creator with certain unalienable rights; that among these, are life, liberty, and the pursuit of happiness. That, to secure these rights, governments are instituted among men, deriving their just powers from the consent of the governed; that, whenever any government becomes destructive of these ends, it is the right of the people to alter or to abolish it, and to institute a new government, laying its foundation on such principles, and organizing its powers in such form, as to them shall seem most likely to effect their safety and happiness. Prudence, indeed,

Lower case a to z, 15 $\frac{7}{8}$ ems

ABCDEFGHIJKLMN OPQRSTUVWXYZ

1234567890

6 POINT NO 50 ^F

WHEN, in the course of human events, it becomes necessary for one people to dissolve the political bands which have connected them with another, and to assume, among the powers of the earth, the separate and equal station to which the laws of nature and of nature's God entitle them, a decent respect to the opinions of mankind requires that they should declare the causes which impel them to the separation. We hold these truths to be self-evident, that all men are created equal; that they are endowed by their Creator with certain unalienable rights; that among these, are life, liberty, and the pursuit of happiness. That, to secure these rights, governments are instituted among men, deriving their just powers from the consent of the governed; that, whenever any form of government becomes destructive of these ends, it is the right of the people to alter or to abolish it, and to institute a new government, laying its foundation on such principles, and organizing its powers in such form, as to them shall seem most likely to effect their safety and happiness.

Lower case a to z, 15 $\frac{3}{4}$ ems

ABCDEFGHIJKLMN OPQRSTUVWXYZ

1234567890

6 POINT NO 46 ^F

WHEN, in the course of human events, it becomes necessary for one people to dissolve the political bands which have connected them with another, and to assume, among the powers of the earth, the separate and equal station to which the laws of nature and of nature's God entitle them, a decent respect to the opinions of mankind requires that they should declare the causes which impel them to the separation. We hold these truths to be self-evident, that all men are created equal; that they are endowed by their Creator with certain unalienable rights; that among these, are life, liberty, and the pursuit of happiness. That, to secure these rights, governments are instituted among men, deriving their just powers from the consent of the governed; that, whenever any form of government becomes destructive of these ends, it is the right of the people to alter or to abolish it, and to institute a new government, laying its foundation on such principles, and organizing its powers in such form, as to them shall seem most likely to effect their safety

Lower case a to z, 16 $\frac{3}{4}$ ems

ABCDEFGHIJKLMN OPQRSTUVWXYZ

1234567890

6 POINT NO 57 ^O

WHEN, in the course of human events, it becomes necessary for one people to dissolve the political bands which have connected them with another, and to assume, among the powers of the earth, the separate and equal station to which the laws of nature and of nature's God entitle them, a decent respect to the opinions of mankind requires that they should declare the causes which impel them to the separation. We hold these truths to be self-evident, that all men are created equal; that they are endowed by their Creator with certain unalienable rights; that among these, are life, liberty, and the pursuit of happiness. That, to secure these rights, governments are instituted among men, deriving their just powers from the consent of the governed; that, whenever any form of government becomes destructive of these ends, it is the right of the people to alter or to abolish it, and to institute a new government, laying its foundation on such principles, and organizing its powers in such form, as to them shall seem most likely to effect their safety

Lower case a to z, 15 $\frac{3}{4}$ ems

ABCDEFGHIJKLMN OPQRSTUVWXYZ

1234567890

6 POINT NO 61 °

WHEN, in the course of human events, it becomes necessary for one people to dissolve the political bands which have connected them with another, and to assume, among the powers of the earth, the separate and equal station to which the laws of nature and of nature's God entitle them, a decent respect to the opinions of mankind requires that they should declare the causes which impel them to the separation. We hold these truths to be self-evident, that all men are created equal; that they are endowed by their Creator with certain unalienable rights; that among these, are life, liberty, and the pursuit of happiness. That, to secure these rights, governments are instituted among men, deriving their just powers from the consent of the governed; that, whenever any form of government becomes destructive of these ends, it is the right of the people to alter or to abolish it, and to institute a new government, laying its foundation on such principles, and organizing its powers in such form, as to them shall seem most

Lower case a to z, 16 $\frac{2}{3}$ ems

ABCDEFGHIJKLMN OPQRSTUVWXYZ

1234567890

6 POINT NO 68 °

WHEN, in the course of human events, it becomes necessary for one people to dissolve the political bands which have connected them with another, and to assume, among the powers of the earth, the separate and equal station to which the laws of nature and of nature's God entitle them, a decent respect to the opinions of mankind requires that they should declare the causes which impel them to the separation. We hold these truths to be self-evident, that all men are created equal; that they are endowed by their Creator with certain unalienable rights; that among these are life, liberty and the pursuit of happiness. That, to secure these rights, governments are instituted among men, deriving their just powers from the consent of the governed; that whenever any form of government becomes destructive of these ends, it is the right of the people to alter or to abolish it, and to institute a new government, laying its foundation on such principles, and organizing its powers in such form as to them

Lower case a to z, 17 ems

ABCDEFGHIJKLMN OPQRSTUVWXYZ

1234567890

6 POINT SELF SPACING NO 37 $\frac{1}{2}$ °

Unit of measure, 11 to Pica

WHEN, in the course of human events, it becomes necessary for one people to dissolve the political bands which have connected them with another, and to assume, among the powers of the earth, the separate and equal station to which the laws of nature and of nature's God entitle them, a decent respect to the opinions of mankind requires that they should declare the causes which impel them to the separation. We hold these truths to be self-evident, that all men are created equal; that they are endowed by their Creator with certain unalienable rights; that among these, are life, liberty, and the pursuit of happiness. That, to secure these rights, governments are instituted among men, deriving their just powers from the consent of the governed; that, whenever any form of government becomes destructive of these ends, it is the right of the people to alter or to abolish it, and to institute a new government, laying its foundation on such principles, and organizing its powers in such form, as

Lower case a to z, 17 ems

ABCDEFGHIJKLMN OPQRSTUVWXYZ

1234567890

6 POINT NO 56 °

WHEN, in the course of human events, it becomes necessary for one people to dissolve the political bands which have connected them with another, and to assume, among the powers of the earth, the separate and equal station to which the laws of nature and of nature's God entitle them, a decent respect to the opinions of mankind requires that they should declare the causes which impel them to the separation. We hold these truths to be self-evident, that all men are created equal; that they are endowed by their Creator with certain unalienable rights; that among these, are life, liberty, and the pursuit of happiness. That, to secure these rights, governments are instituted among men, deriving their just powers from the consent of the governed; that, whenever any form of government becomes destructive of these ends, it is the right of the people to alter or to abolish it, and to institute a new government, laying its foundation on such principles, and organizing its powers in such

Lower case a to z, 18 ems

ABCDEFGHIJKLMN OPQRSTUVWXYZ

1234567890

7 POINT NO 65 ^ε

WHEN, in the course of human events, it becomes necessary for one people to dissolve the political bands which have connected them with another, and to assume, among the powers of the earth, the separate and equal station to which the laws of nature and of nature's God entitle them, a decent respect to the opinions of mankind requires that they should declare the causes which impel them to the separation. We hold these truths to be self-evident, that all men are created equal; that they are endowed by their Creator with certain unalienable rights; that among these, are life, liberty, and the pursuit of happiness. That, to secure these rights, governments are instituted among men, deriving their just powers from the consent of the governed; that, whenever any form of government becomes destructive of these ends, it is the right of the people to alter or to abolish it, and to institute a new government,

Lower case a to z, 13½ ems

ABCDEFGHIJKLMNOPQRSTUVWXYZ
1234567890

7 POINT NO 47 ^φ

WHEN, in the course of human events, it becomes necessary for one people to dissolve the political bands which have connected them with another, and to assume, among the powers of the earth, the separate and equal station to which the laws of nature and of nature's God entitle them, a decent respect to the opinions of mankind requires that they should declare the causes which impel them to the separation. We hold these truths to be self-evident, that all men are created equal; that they are endowed by their Creator with certain unalienable rights; that among these, are life, liberty, and the pursuit of happiness. That, to secure these rights, governments are instituted among men, deriving their just powers from the consent of the governed; that, whenever any form of government becomes destructive of these ends, it is the right of the people to alter or

Lower case a to z, 14½ ems

ABCDEFGHIJKLMNOPQRSTUVWXYZ
1234567890

7 POINT NO 66 ^ε

WHEN, in the course of human events, it becomes necessary for one people to dissolve the political bands which have connected them with another, and to assume, among the powers of the earth, the separate and equal station to which the laws of nature and of nature's God entitle them, a decent respect to the opinions of mankind requires that they should declare the causes which impel them to the separation. We hold these truths to be self-evident, that all men are created equal; that they are endowed by their Creator with certain unalienable rights; that among these are life, liberty, and the pursuit of happiness. That, to secure these rights, governments are instituted among men, deriving their just powers from the consent of the governed; that whenever any form of government becomes destructive of these ends, it is the right of the people to

Lower case a to z, 14¼ ems

ABCDEFGHIJKLMNOPQRSTUVWXYZ
1234567890

7 POINT SELF SPACING NO 23½ ^β

Unit of measure, 11 to Pica

WHEN, in the course of human events, it becomes necessary for one people to dissolve the political bands which have connected them with another, and to assume, among the powers of the earth, the separate and equal station to which the laws of nature and of nature's God entitle them, a decent respect to the opinions of mankind requires that they should declare the causes which impel them to the separation. We hold these truths to be self-evident, that all men are created equal; that they are endowed by their Creator with certain unalienable rights; that among these, are life, liberty, and the pursuit of happiness. That, to secure these rights, governments are instituted among men, deriving their just powers from the consent of the governed; that, whenever any form of government becomes destructive of these ends, it is the right of

Lower case a to z, 14½ ems

ABCDEFGHIJKLMNOPQRSTUVWXYZ
1234567890

7 POINT NO 67 [‡]

WHEN, in the course of human events, it becomes necessary for one people to dissolve the political bands which have connected them with another, and to assume, among the powers of the earth, the separate and equal station to which the laws of nature and of nature's God entitle them, a decent respect to the opinions of mankind requires that they should declare the causes which impel them to the separation. We hold these truths to be self-evident, that all men are created equal; that they are endowed by their Creator with certain unalienable rights; that among these, are life, liberty, and the pursuit of happiness. That, to secure these rights, governments are instituted among men, deriving their just powers from the consent of the governed; that, *whenever any form of government becomes destructive of these ends, it is the right of*

Lower case a to z, 14¾ ems

ABCDEFGHIJKLMNOPQRSTUVWXYZ
1234567890

7 POINT NO 60 [^]

WHEN, in the course of human events, it becomes necessary for one people to dissolve the political bands which have connected them with another, and to assume, among the powers of the earth, the separate and equal station to which the laws of nature and of nature's God entitle them, a decent respect to the opinions of mankind requires that they should declare the causes which impel them to the separation. We hold these truths to be self-evident, that all men are created equal; that they are endowed by their Creator with certain unalienable rights; that among these, are life, liberty, and the pursuit of happiness. That, to secure these rights, governments are instituted among men, deriving their just powers from the consent of the governed; that, *whenever any form of government becomes destructive of these ends, it is the*

Lower case a to z, 14⅔ ems

ABCDEFGHIJKLMNOPQRSTUVWXYZ
1234567890

7 POINT NO 50 [‡]

WHEN, in the course of human events, it becomes necessary for one people to dissolve the political bands which have connected them with another, and to assume, among the powers of the earth, the separate and equal station to which the laws of nature and of nature's God entitle them, a decent respect to the opinions of mankind requires that they should declare the causes which impel them to the separation. We hold these truths to be self-evident, that all men are created equal; that they are endowed by their Creator with certain unalienable rights; that among these, are life, liberty, and the pursuit of happiness. That, to secure these rights, governments are instituted among men, deriving their just powers from the consent of the governed; that, *whenever any form of government becomes destructive of these ends, it*

Lower case a to z, 14¾ ems

ABCDEFGHIJKLMNOPQRSTUVWXYZ
1234567890

7 POINT NO 57 [°]

WHEN, in the course of human events, it becomes necessary for one people to dissolve the political bands which have connected them with another, and to assume, among the powers of the earth, the separate and equal station to which the laws of nature and of nature's God entitle them, a decent respect to the opinions of mankind requires that they should declare the causes which impel them to the separation. We hold these truths to be self-evident, that all men are created equal; that they are endowed by their Creator with certain unalienable rights; that among these, are life, liberty, and the pursuit of happiness. That, to secure these rights, governments are instituted among men, deriving their just powers from the consent of the governed; that, *whenever any form of government becomes destructive of these ends,*

Lower case a to z, 14¾ ems

ABCDEFGHIJKLMNOPQRSTUVWXYZ
1234567890

7 POINT NO 53 ^E

WHEN, in the course of human events, it becomes necessary for one people to dissolve the political bands which have connected them with another, and to assume, among the powers of the earth, the separate and equal station to which the laws of nature and of nature's God entitle them, a decent respect to the opinions of mankind requires that they should declare the causes which impel them to the separation. We hold these truths to be self-evident, that all men are created equal; that they are endowed by their Creator with certain unalienable rights; that among these, are life, liberty, and the pursuit of happiness. That, to secure these rights, governments are instituted among men, deriving their just powers from the consent of the governed; that, whenever any form of government becomes destructive

Lower case a to z, 15½ ems

ABCDEFGHIJKLMNOPQRSTUVWXYZ
1234567890

7 POINT NO 54 ^C

WHEN, in the course of human events, it becomes necessary for one people to dissolve the political bands which have connected them with another, and to assume, among the powers of the earth, the separate and equal station to which the laws of nature and of nature's God entitle them, a decent respect to the opinions of mankind requires that they should declare the causes which impel them to the separation. We hold these truths to be self-evident, that all men are created equal; that they are endowed by their Creator with certain unalienable rights; that among these, are life, liberty, and the pursuit of happiness. That, to secure these rights, governments are instituted among men, deriving their just powers from the consent of the governed; that, whenever any form of government becomes destructive of these

Lower case a to z, 15 ems

ABCDEFGHIJKLMNOPQRSTUVWXYZ
1234567890

7 POINT NO 61 ^D

WHEN, in the course of human events, it becomes necessary for one people to dissolve the political bands which have connected them with another, and to assume, among the powers of the earth, the separate and equal station to which the laws of nature and of nature's God entitle them, a decent respect to the opinions of mankind requires that they should declare the causes which impel them to the separation. We hold these truths to be self-evident, that all men are created equal; that they are endowed by their Creator with certain unalienable rights; that among these, are life, liberty, and the pursuit of happiness. That, to secure these rights, governments are instituted among men, deriving their just powers from the consent of the governed; that, whenever any form of government

Lower case a to z, 15⅓ ems

ABCDEFGHIJKLMNOPQRSTUVWXYZ
1234567890

7 POINT NO 68 ^E

WHEN, in the course of human events, it becomes necessary for one people to dissolve the political bands which have connected them with another, and to assume, among the powers of the earth, the separate and equal station to which the laws of nature and of nature's God entitle them, a decent respect to the opinions of mankind requires that they should declare the causes which impel them to the separation. We hold these truths to be self-evident, that all men are created equal; that they are endowed by their Creator with certain unalienable rights; that among these, are life, liberty, and the pursuit of happiness. That, to secure these rights, governments are instituted among men, deriving their just powers from the consent of the governed; that, whenever any form of govern-

Lower case a to z, 15½ ems

ABCDEFGHIJKLMNOPQRSTUVWXYZ
1234567890

7 POINT NO 46 ^f

WHEN, in the course of human events, it becomes necessary for one people to dissolve the political bands which have connected them with another, and to assume, among the powers of the earth, the separate and equal station to which the laws of nature and of nature's God entitle them, a decent respect to the opinions of mankind requires that they should declare the causes which impel them to the separation. We hold these truths to be self-evident, that all men are created equal; that they are endowed by their Creator with certain unalienable rights; that among these, are life, liberty, and the pursuit of happiness. That, to secure these rights, governments are instituted among men, deriving their just powers from the consent of the governed; that, whenever any form of govern-

Lower case a to z, 16 ems

ABCDEFGHIJKLMNOPQRSTUVWXYZ
1234567890

7 POINT SELF SPACING NO 38½ ^g

Unit of measure, 10 to Pica

WHEN, in the course of human events, it becomes necessary for one people to dissolve the political bands which have connected them with another, and to assume, among the powers of the earth, the separate and equal station to which the laws of nature and of nature's God entitle them, a decent respect to the opinions of mankind requires that they should declare the causes which impel them to the separation. We hold these truths to be self-evident, that all men are created equal; that they are endowed by their Creator with certain unalienable rights; that among these, are life, liberty, and the pursuit of happiness. That, to secure these rights, governments are instituted among men, deriving their just powers from the consent of the governed; that, whenever

Lower case a to z, 16 ems

ABCDEFGHIJKLMNOPQRSTUVWXYZ
1234567890

7 POINT NO 56 ^h

WHEN, in the course of human events, it becomes necessary for one people to dissolve the political bands which have connected them with another, and to assume, among the powers of the earth, the separate and equal station to which the laws of nature and of nature's God entitle them, a decent respect to the opinions of mankind requires that they should declare the causes which impel them to the separation. We hold these truths to be self-evident, that all men are created equal; that they are endowed by their Creator with certain unalienable rights; that among these, are life, liberty, and the pursuit of happiness. That, to secure these rights, governments are instituted among men, deriving their just powers from the consent of the governed;

Lower case a to z, 17 ems

ABCDEFGHIJKLMNOPQRSTUVWXYZ
1234567890

8 POINT CENTURY ROMAN ⁱ

WHEN, in the course of human events, it becomes necessary for one people to dissolve the political bands which have connected them with another, and to assume, among the powers of the earth, the separate and equal station to which the laws of nature and of nature's God entitle them, a decent respect to the opinions of mankind requires that they should declare the causes which impel them to the separation. We hold these truths to be self-evident, that all men are created equal; that they are endowed by their Creator with certain unalienable rights; that among these, are life, liberty, and the pursuit of happiness. That, to secure these rights, governments are instituted among men, deriving their

Lower case a to z, 12 ems

ABCDEFGHIJKLMNOPQRSTUVWXYZ
1234567890

8 POINT NO 64 ^E

WHEN, in the course of human events, it becomes necessary for one people to dissolve the political bands which have connected them with another, and to assume, among the powers of the earth, the separate and equal station to which the laws of nature and of nature's God entitle them, a decent respect to the opinions of mankind requires that they should declare the causes which impel them to the separation. We hold these truths to be self-evident, that all men are created equal; that they are endowed by their Creator with certain unalienable rights; that among these, are life, liberty, and the pursuit of happiness. That, to secure these rights, gov-

Lower case a to z, 13½ ems

ABCDEFGHIJKLMNOPQRSTUVWXYZ
1234567890

8 POINT NO 60 ^A

WHEN, in the course of human events, it becomes necessary for one people to dissolve the political bands which have connected them with another, and to assume, among the powers of the earth, the separate and equal station to which the laws of nature and of nature's God entitle them, a decent respect to the opinions of mankind requires that they should declare the causes which impel them to the separation. We hold these truths to be self-evident, that all men are created equal; that they are endowed by their Creator with certain unalienable rights; that among these, are life, liberty, and the pursuit of happiness. That, to secure these

Lower case a to z, 13 ems

ABCDEFGHIJKLMNOPQRSTUVWXYZ
1234567890

8 POINT NO 47 ^F

WHEN, in the course of human events, it becomes necessary for one people to dissolve the political bands which have connected them with another, and to assume, among the powers of the earth, the separate and equal station to which the laws of nature and of nature's God entitle them, a decent respect to the opinions of mankind requires that they should declare the causes which impel them to the separation. We hold these truths to be self-evident, that all men are created equal; that they are endowed by their Creator with certain unalienable rights; that among these, are life, liberty, and the pursuit of happiness. That, to secure these

Lower case a to z, 13½ ems

ABCDEFGHIJKLMNOPQRSTUVWXYZ
1234567890

8 POINT NO 65 ^E

WHEN, in the course of human events, it becomes necessary for one people to dissolve the political bands which have connected them with another, and to assume, among the powers of the earth, the separate and equal station to which the laws of nature and of nature's God entitle them, a decent respect to the opinions of mankind requires that they should declare the causes which impel them to the separation. We hold these truths to be self-evident, that all men are created equal; that they are endowed by their Creator with certain unalienable rights; that among these, are life, liberty, and the pursuit of happiness. That to secure these

Lower case a to z, 14 ems

ABCDEFGHIJKLMNOPQRSTUVWXYZ
1234567890

8 POINT NO 67 ^ε

WHEN, in the course of human events, it becomes necessary for one people to dissolve the political bands which have connected them with another, and to assume, among the powers of the earth, the separate and equal station to which the laws of nature and of nature's God entitle them, a decent respect to the opinions of mankind requires that they should declare the causes which impel them to the separation. We hold these truths to be self-evident, that all men are created equal; that they are endowed by their Creator with certain unalienable rights; *that among these, are life, liberty, and the pursuit of happiness. That, to*

Lower case a to z, 14 ems

ABCDEFGHIJKLMNOPQRSTUVWXYZ
1234567890

8 POINT SELF SPACING NO 18½ ^δ

Unit of measure, 10 to Pica

WHEN, in the course of human events, it becomes necessary for one people to dissolve the political bands which have connected them with another, and to assume, among the powers of the earth, the separate and equal station to which the laws of nature and of nature's God entitle them, a decent respect to the opinions of mankind requires that they should declare the causes which impel them to the separation. We hold these truths to be self-evident, that all men are created equal; that they are endowed by their Creator with certain unalienable rights; *that among these, are life, liberty, and the pursuit of happiness. That.*

Lower case a to z, 14½ ems

ABCDEFGHIJKLMNOPQRSTUVWXYZ
1234567890

8 POINT NO 66 ^ε

WHEN, in the course of human events, it becomes necessary for one people to dissolve the political bands which have connected them with another, and to assume, among the powers of the earth, the separate and equal station to which the laws of nature and of nature's God entitle them, *a decent respect to the opinions of mankind* requires that they should declare the causes which impel them to the separation. We hold these truths to be self-evident, that all men are created equal; that they are endowed by their Creator with certain unalienable rights; that among these are life, liberty, and the pursuit of happiness. That,

Lower case a to z, 14 ems

ABCDEFGHIJKLMNOPQRSTUVWXYZ
1234567890

8 POINT NO 61 ^δ

WHEN, in the course of human events, it becomes necessary for one people to dissolve the political bands which have connected them with another, and to assume, among the powers of the earth, the separate and equal station to which the laws of nature and of nature's God entitle them, a decent respect to the opinions of mankind requires that they should declare the causes which impel them to the separation. We hold these truths to be self-evident, that all men are created equal; that they are endowed by their Creator with certain unalienable rights; *that among these, are life, liberty, and the pursuit of happiness.*

Lower case a to z, 14½ ems

ABCDEFGHIJKLMNOPQRSTUVWXYZ
1234567890

8 POINT NO 54 °

WHEN, in the course of human events, it becomes necessary for one people to dissolve the political bands which have connected them with another, and to assume, among the powers of the earth, the separate and equal station to which the laws of nature and of nature's God entitle them, a decent respect to the opinions of mankind requires that they should declare the causes which impel them to the separation. We hold these truths to be self-evident, that all men are created equal; that they are endowed by their Creator with certain unalienable rights; that among these, are life, liberty, and the pursuit of happiness.

Lower case a to z, 14¼ ems

ABCDEFGHIJKLMNOPQRSTUVWXYZ
1234567890

8 POINT NO 50 °

WHEN, in the course of human events, it becomes necessary for one people to dissolve the political bands which have connected them with another, and to assume, among the powers of the earth, the separate and equal station to which the laws of nature and of nature's God entitle them, a decent respect to the opinions of mankind requires that they should declare the causes which impel them to the separation. We hold these truths to be self-evident, that all men are created equal; that they are endowed by their Creator with certain unalienable rights; that among these, are life, liberty, and the pursuit of happiness.

Lower case a to z, 14 ems

ABCDEFGHIJKLMNOPQRSTUVWXYZ
1234567890

8 POINT NO 57 °

WHEN, in the course of human events, it becomes necessary for one people to dissolve the political bands which have connected them with another, and to assume, among the powers of the earth, the separate and equal station to which the laws of nature and of nature's God entitle them, a decent respect to the opinions of mankind requires that they should declare the causes which impel them to the separation. We hold these truths to be self-evident, that all men are created equal; that they are endowed by their Creator with certain unalienable rights; that among these, are life, liberty, and the pursuit of happiness.

Lower case a to z, 14 ems

ABCDEFGHIJKLMNOPQRSTUVWXYZ
1234567890

8 POINT SELF SPACING NO 34½ °

Unit of measure, 10 to Pica

WHEN, in the course of human events, it becomes necessary for one people to dissolve the political bands which have connected them with another, and to assume, among the powers of the earth, the separate and equal station to which the laws of nature and of nature's God entitle them, a decent respect to the opinions of mankind requires that they should declare the causes which impel them to the separation. We hold these truths to be self-evident, that all men are created equal; that they are endowed by their Creator with certain unalienable rights; that among these, are life, liberty, and the pursuit of happiness.

Lower case a to z, 14½ ems

ABCDEFGHIJKLMNOPQRSTUVWXYZ
1234567890

8 POINT NO 53 ^ε

WHEN, in the course of human events, it becomes necessary for one people to dissolve the political bands which have connected them with another, and to assume among the powers of the earth, the separate and equal station to which the laws of nature and of nature's God entitle them, a decent respect to the opinion of mankind requires that they should declare the causes which impel them to the separation. We hold these truths to be self-evident, that all men are created equal; that they are endowed by their Creator with certain *unalienable rights; that among these, are life, liberty, and the pur-*

Lower case a to z, 14 $\frac{3}{4}$ ems

ABCDEFGHIJKLMNOPQRSTUVWXYZ
1234567890

8 POINT NO 68 ^ε

WHEN, in the course of human events, it becomes necessary for one people to dissolve the political bands which have connected them with another, and to assume, among the powers of the earth, the separate and equal station to which the laws of nature and of nature's God entitle them, a decent respect to the opinions of mankind requires that they should declare the causes which impel them to the separation. We hold these truths to be self-evident, that all men are created equal; that they are endowed by their Creator with *certain unalienable rights; that among these, are life, liberty, and the*

Lower case a to z, 14 $\frac{1}{2}$ ems

ABCDEFGHIJKLMNOPQRSTUVWXYZ
1234567890

8 POINT NO 46 ^f

WHEN, in the course of human events, it becomes necessary for one people to dissolve the political bands which have connected them with another, and to assume, among the powers of the earth, the separate and equal station to which the laws of nature and of nature's God entitle them, a decent respect to the opinions of mankind requires that they should declare the causes which impel them to the separation. We hold these truths to be self-evident, that all men are created equal; that they are endowed by their *Creator with certain unalienable rights; that among these, are life,*

Lower case a to z, 15 $\frac{1}{4}$ ems

ABCDEFGHIJKLMNOPQRSTUVWXYZ
1234567890

8 POINT NO 56 ^o

WHEN, in the course of human events, it becomes necessary for one people to dissolve the political bands which have connected them with another, and to assume, among the powers of the earth, the separate and equal station to which the laws of nature and of nature's God entitle them, a decent respect to the opinions of mankind requires that they should declare the causes which impel them to the separation. We hold these truths to be self-evident, that all men are created equal; that they are *endowed by their Creator with certain unalienable rights; that*

Lower case a to z, 15 $\frac{3}{4}$ ems

ABCDEFGHIJKLMNOPQRSTUVWXYZ
1234567890

8 POINT SELF SPACING NO 48½⁸

Unit of measure, 9 to Pica

WHEN, in the course of human events, it becomes necessary for one people to dissolve the political bands which have connected them with another, and to assume, among the powers of the earth, the separate and equal station to which the laws of nature and of nature's God entitle them, a decent respect to the opinions of mankind requires that they should declare the causes which impel them to the separation. We hold these truths to be self-evident, that all men are created equal; that *they are endowed by their Creator with certain unalienable*

Lower case a to z, 15½ ems

ABCDEFGHIJKLMNOPQRSTUVWXYZ
1234567890

9 POINT CENTURY ROMAN⁸

WHEN, in the course of human events, it becomes necessary for one people to dissolve the political bands which have connected them with another, and to assume among the powers of the earth, the separate and equal station to which the laws of nature and of nature's God entitle them, a decent respect to the opinions of mankind requires that they should declare the causes which impel them to the separation. We hold these truths to be self-evident, that all men are created equal; that they *are endowed by their Creator with certain unalienable rights; that among*

Lower case a to z, 12¼ ems

ABCDEFGHIJKLMNOPQRSTUVWXYZ
1234567890

9 POINT NO 67⁸

WHEN, in the course of human events, it becomes necessary for one people to dissolve the political bands which have connected them with another, and to assume, among the powers of the earth, the separate and equal station to which the laws of nature and of nature's God entitle them, a decent respect to the opinions of mankind requires that they should declare the causes which impel them to the separation. We hold these truths to be self-evident, that all men are created equal; *that they are endowed by their Creator with certain unalienable rights; that*

Lower case a to z, 12½ ems

ABCDEFGHIJKLMNOPQRSTUVWXYZ
1234567890

9 POINT NO 60⁸

WHEN, in the course of human events, it becomes necessary for one people to dissolve the political bands which have connected them with another, and to assume, among the powers of the earth, the separate and equal station to which the laws of nature and of nature's God entitle them, a decent respect to the opinions of mankind requires that they should declare the causes which impel them to the separation. We hold these truths to be self-evident, that all men are *created equal; that they are endowed by their Creator with certain un-*

Lower case a to z, 12½ ems

ABCDEFGHIJKLMNOPQRSTUVWXYZ
1234567890

9 POINT NO 65 [ⓔ]

WHEN, in the course of human events, it becomes necessary for one people to dissolve the political bands which have connected them with another, and to assume, among the powers of the earth, the separate and equal station to which the laws of nature and of nature's God entitle them, a decent respect to the opinions of mankind requires that they should declare the causes which impel them to the separation. We hold these truths to be self-evident, that all men are created equal; that they are endowed by their Creator with certain

Lower case a to z, 12¼ ems

ABCDEFGHIJKLMNOPQRSTUVWXYZ
1234567890

9 POINT NO 64 [ⓔ]

WHEN, in the course of human events, it becomes necessary for one people to dissolve the political bands which have connected them with another, and to assume, among the powers of the earth, the separate and equal station to which the laws of nature and of nature's God entitle *them*, a decent respect to the opinions of mankind requires that they should declare the causes which impel them to the separation. We hold these truths to be self-evident, that all men are created equal; that they are endowed by their Creator with

Lower case a to z, 13 ems

ABCDEFGHIJKLMNOPQRSTUVWXYZ
1234567890

9 POINT NO 53 [ⓔ]

WHEN, in the course of human events, it becomes necessary for one people to dissolve the political bands which have connected them with another, and to assume, among the powers of the earth, the separate and equal station to which the laws of nature and of nature's God entitle them, a decent respect to the opinions of mankind requires that they should declare the causes which impel them to the separation. We hold these truths to be self-evident, that all men are created equal; that they are endowed by their Creator with

Lower case a to z, 13 ems

ABCDEFGHIJKLMNOPQRSTUVWXYZ
1234567890

9 POINT NO 54 [ⓔ]

WHEN, in the course of human events, it becomes necessary for one people to dissolve the political bands which have connected them with another, and to assume, among the powers of the earth, the separate and equal station to which the laws of nature and of nature's God entitle them, a decent respect to the opinions of mankind requires that they should declare the causes which impel them to the separation. We hold these truths to be self-evident, that all men are created equal; that they are endowed by their Creator

Lower case a to z, 13 ems

ABCDEFGHIJKLMNOPQRSTUVWXYZ
1234567890

9 POINT NO 47

WHEN, in the course of human events, it becomes necessary for one people to dissolve the political bands which have connected them with another, and to assume, among the powers of the earth, the separate and equal station to which the laws of nature and of nature's God entitle them, a decent respect to the opinions of mankind requires that they should declare the causes which impel them to the separation. We hold these truths to be self-evident, *that all men are created equal; that they are endowed by their Creator*

Lower case a to z, 13 ems

ABCDEFGHIJKLMNOPQRSTUVWXYZ
1234567890

9 POINT NO 57

WHEN, in the course of human events, it becomes necessary for one people to dissolve the political bands which have connected them with another, and to assume, among the powers of the earth, the separate and equal station to which the laws of nature and of nature's God entitle them, a decent respect to the opinions of mankind requires that they should declare the causes which impel them to the separation. We hold these truths to be self-evident, *that all men are created equal; that they are endowed by their*

Lower case a to z, 13½ ems

ABCDEFGHIJKLMNOPQRSTUVWXYZ
1234567890

9 POINT SELF SPACING NO 32½

Unit of measure, 9 to Pica

WHEN, in the course of human events, it becomes necessary for one people to dissolve the political bands which have connected them with another, and to assume, among the powers of the earth, the separate and equal station to which the laws of nature and of nature's God entitle them, a decent respect to the opinions of mankind requires that they should declare the causes which impel them to the separation. We hold these truths to be self-evident, *that all men are created equal; that they are endowed*

Lower case a to z, 13¾ ems

ABCDEFGHIJKLMNOPQRSTUVWXYZ
1234567890

9 POINT NO 50

WHEN, in the course of human events, it becomes necessary for one people to dissolve the political bands which have connected them with another, and to assume, among the powers of the earth, the separate and equal station to which the laws of nature and of nature's God entitle them, a decent respect to the opinions of mankind requires that they should declare the causes which impel them to the separation. We hold these truths to be self-evident, *that all men are created equal; that they*

Lower case a to z, 14 ems

ABCDEFGHIJKLMNOPQRSTUVWXYZ
1234567890

9 POINT NO 61 °

WHEN, in the course of human events, it becomes necessary for one people to dissolve the political bands which have connected them with another, and to assume, among the powers of the earth, the separate and equal station to which the laws of nature and of nature's God entitle them, a decent respect to the opinions of mankind requires that they should declare the causes which impel them to the separation. We hold these *truths to be self-evident, that all men are created equal; that*

Lower case a to z, 14¼ ems

ABCDEFGHIJKLMNOPQRSTUVWXYZ
1234567890

9 POINT NO 56 °

WHEN, in the course of human events, it becomes necessary for one people to dissolve the political bands which have connected them with another, and to assume, among the powers of the earth, the separate and equal station to which the laws of nature and of nature's God entitle them, a decent respect to the opinions of mankind requires that they should declare the causes which impel them to the separation. We hold *these truths to be self-evident, that all men are created equal;*

Lower case a to z, 15 ems

ABCDEFGHIJKLMNOPQRSTUVWXYZ
1234567890

9 POINT NO 46 °

WHEN, in the course of human events, it becomes necessary for one people to dissolve the political bands which have connected them with another, and to assume, among the powers of the earth, the separate and equal station to which the laws of nature and of nature's God entitle them, a decent respect to the opinions of mankind requires that they should declare the causes which impel them to the separation. We hold these truths to be self-evident, that all men are created

Lower case a to z, 15 ems

ABCDEFGHIJKLMNOPQRSTUVWXYZ
1234567890

10 POINT CENTURY ROMAN °

WHEN, in the course of human events, it becomes necessary for one people to dissolve the political bands which have connected them with another, and to assume, among the powers of the earth, the separate and equal station to which the laws of nature and of nature's God entitle them, a decent respect to the opinions of mankind requires that they should declare the causes which *impel them to the separation. We hold these truths to be self-evident*

Lower case a to z, 12 ems

ABCDEFGHIJKLMNOPQRSTUVWXYZ
1234567890

10 POINT CENTURY ROMAN NO 2 ^B

When, in the course of human events, it becomes necessary for one people to dissolve the political bands which have connected them with another, and to assume, among the powers of the earth, the separate and equal station to which the laws of nature and of nature's God entitle them, a decent respect to the opinions of mankind requires that they should declare the causes which impel them to the separation. We hold these truths to be self-

Lower case a to z, 12 ems

ABCDEFGHIJKLMNOPQRSTUVWXYZ
1234567890

10 POINT NO 65 ^E

WHEN, in the course of human events, it becomes necessary for one people to dissolve the political bands which have connected them with another, and to assume, among the powers of the earth, the separate and equal station to which the laws of nature and of nature's God entitle them, a decent respect to the opinions of mankind requires that they should declare the causes *which impel them to the separation.* We hold these truths to be

Lower case a to z, 12¼ ems

ABCDEFGHIJKLMNOPQRSTUVWXYZ
1234567890

10 POINT NO 67 ^E

WHEN, in the course of human events, it becomes necessary for one people to dissolve the political bands which have connected them with another, and to assume, among the powers of the earth, the separate and equal station to which the laws of nature and of nature's God entitle them, a decent respect to the opinions of mankind requires that they should declare the causes *which impel them to the separation.* We hold these truths to be

Lower case a to z, 12½ ems

ABCDEFGHIJKLMNOPQRSTUVWXYZ
1234567890

10 POINT NO 54 ^C

WHEN, in the course of human events, it becomes necessary for one people to dissolve the political bands which have connected them with another, and to assume, among the powers of the earth, the separate and equal station to which the laws of nature and of nature's God entitle them, a decent respect to the opinions of mankind requires that they should declare the *causes which impel them to the separation.* We hold these truths to be

Lower case a to z, 12 3/5 ems

ABCDEFGHIJKLMNOPQRSTUVWXYZ
1234567890

10 POINT NO 60 ^A

WHEN, in the course of human events, it becomes necessary for one people to dissolve the political bands which have connected them with another, and to assume, among the powers of the earth, the separate and equal station to which the laws of nature and of nature's God entitle them, a decent respect to the opinions of mankind requires that they should declare the *causes which impel them to the separation. We hold these*

Lower case a to z, 12 $\frac{2}{3}$ ems

ABCDEFGHIJKLMNOPQRSTUVWXYZ
1234567890

10 POINT NO 47 ^F

WHEN, in the course of human events, it becomes necessary for one people to dissolve the political bands which have connected them with another, and to assume, among the powers of the earth, the separate and equal station to which the laws of nature and of nature's God entitle them, a decent respect to the opinions of mankind requires that they should declare *the causes which impel them to the separation. We hold these*

Lower case a to z, 13 ems

ABCDEFGHIJKLMNOPQRSTUVWXYZ
1234567890

10 POINT NO 64 ^E

WHEN, in the course of human events, it becomes necessary for one people to dissolve the political bands which have connected them with another, and to assume, among the powers of the earth, the separate and equal station to which the laws of nature and of nature's God entitle them, a decent respect to the *opinions of mankind requires that they should declare the causes which impel them to the separation. We*

Lower case a to z, 13 ems

ABCDEFGHIJKLMNOPQRSTUVWXYZ
1234567890

10 POINT NO 57 ^D

WHEN, in the course of human events, it becomes necessary for one people to dissolve the political bands which have connected them with another, and to assume, among the powers of the earth, the separate and equal station to which the laws of nature and of nature's God entitle them, a decent respect to the opinions of mankind requires that they should *declare the causes which impel them to the separation. We*

Lower case a to z, 13 $\frac{1}{4}$ ems

ABCDEFGHIJKLMNOPQRSTUVWXYZ
1234567890

10 POINT NO 50 F

WHEN, in the course of human events, it becomes necessary for one people to dissolve the political bands which have connected them with another, and to assume, among the powers of the earth, the separate and equal station to which the laws of nature and of nature's God entitle them, a decent respect to the opinions of mankind requires that *they should declare the causes which impel them to the sepa-*

Lower case a to z, 13¾ ems

ABCDEFGHIJKLMNOPQRSTUVWXYZ
1234567890

10 POINT NO 56 D

WHEN, in the course of human events, it becomes necessary for one people to dissolve the political bands which have connected them with another, and to assume, among the powers of the earth, the separate and equal station to which the laws of nature and of nature's God entitle them, a decent respect to the opinions of mankind requires that *they should declare the causes which impel them to the*

Lower case a to z, 13¾ ems

ABCDEFGHIJKLMNOPQRSTUVWXYZ
1234567890

10 POINT SELF SPACING NO 17½ B

Unit of measure, 8 to Pica

WHEN, in the course of human events, it becomes necessary for one people to dissolve the political bands which have connected them with another, and to assume, among the powers of the earth, the separate and equal station to which the laws of nature and of nature's God entitle them, a decent respect to the opinions of mankind requires that *they should declare the causes which impel*

Lower case a to z, 14 ems

ABCDEFGHIJKLMNOPQRSTUVWXYZ
1234567890

11 POINT NO 60 A

WHEN, in the course of human events, it becomes necessary for one people to dissolve the political bands which have connected them with another, and to assume, among the powers of the earth, the separate and equal station to which the laws of nature and of nature's God entitle them, a decent respect to the opinions of mankind requires that they should declare the causes which impel them to the separation. We

Lower case a to z, 11½ ems

ABCDEFGHIJKLMNOPQRSTUVWXYZ
1234567890

11 POINT NO 67 ϵ

WHEN, in the course of human events, it becomes necessary for one people to dissolve the political bands which have connected them with another, and to assume, among the powers of the earth, the separate and equal station to which the laws of nature and of nature's God entitle them, a decent respect to the opinions of mankind requires that they should declare the causes which impel them to the separation. We hold these truths to be self-evident, that all men are created equal; that they are endowed by their Creator *with certain unalienable rights; that among these, are life,*

Lower case a to z, 12 ems

ABCDEFGHIJKLMNOPQRSTUVWXYZ
1234567890

11 POINT NO 65 ϵ

WHEN, in the course of human events, it becomes necessary for one people to dissolve the political bands which have connected them with another, and to assume, among the powers of the earth, the separate and equal station to which the laws of nature and of nature's God entitle them, a decent respect to the opinions of mankind requires that they should declare the causes which impel them to the separation. We hold these truths to be self-evident, that all men are created equal; that they are endowed by their Creator *with certain unalienable rights, that among these, are life,*

Lower case a to z, 12¼ ems

ABCDEFGHIJKLMNOPQRSTUVWXYZ
1234567890

11 POINT NO 54 \circ

WHEN, in the course of human events, it becomes necessary for one people to dissolve the political bands which have connected them with another, and to assume, among the powers of the earth, the separate and equal station to which the laws of nature and of nature's God entitle them, a decent respect to the opinions of mankind requires that they should declare the causes which impel them to the separation. We hold these truths to be self-evident, that all men are created equal; that they are endowed by their Creator *with certain unalienable rights; that among these, are*

Lower case a to z, 12¼ ems

ABCDEFGHIJKLMNOPQRSTUVWXYZ
1234567890

11 POINT NO 47 F

WHEN, in the course of human events, it becomes necessary for one people to dissolve the political bands which have connected them with another, and to assume, among the powers of the earth, the separate and equal station to which the laws of nature and of nature's God entitle them, a decent respect to the opinions of mankind requires that they should declare the causes which impel them to the separation. We hold these truths to be self-evident, that all men are created equal; *that they are endowed by their Creator with certain un-*

Lower case a to z, 13¼ ems

ABCDEFGHIJKLMNOPQRSTUVWXYZ
1234567890

11 POINT NO 64 E

WHEN, in the course of human events, it becomes necessary for one people to dissolve the political bands which have connected them with another, and to assume among the powers of the earth the separate and equal station to which the laws of nature and of nature's God entitle them, a decent respect to the opinions of mankind requires that they should declare the causes which impel them to the separation. We hold these truths to be self-evident, that *all men are created equal; that they are endowed by*

Lower case a to z, 13¾ ems

ABCDEFGHIJKLMNOPQRSTUVWXYZ
1234567890

11 POINT SELF SPACING NO 21½ B

Unit of measure, 7 to Pica

WHEN, in the course of human events, it becomes necessary for one people to dissolve the political bands which have connected them with another, and to assume, among the powers of the earth, the separate and equal station to which the laws of nature and of nature's God entitle them, a decent respect to the opinions of mankind requires that they should declare the causes which impel them to the separation. We hold these truths *to be self-evident, that all men are created equal;*

Lower case a to z, 14½ ems

ABCDEFGHIJKLMNOPQRSTUVWXYZ
1234567890

12 POINT NO 60 ⁴

WHEN, in the course of human events, it becomes necessary for one people to dissolve the political bands which have connected them with another, and to assume, among the powers of the earth, the separate and equal station to which the laws of nature and of nature's God entitle them, a decent respect to the opinions of mankind requires that they should declare the causes which impel them to the separation. We hold these truths to be self-evident, that all men are created equal; that they are endowed by their Creator with certain unalienable rights; that among these, are life, liberty, and the pursuit of happiness. That, to secure these rights, governments are instituted among men, deriving their just powers from the consent of the gov-

Lower case a to z, 12¼ ems

ABCDEFGHIJKLMNOPQRSTUVWXYZ

1234567890

12 POINT NO 67 ⁵

WHEN, in the course of human events, it becomes necessary for one people to dissolve the political bands which have connected them with another, and to assume, among the powers of the earth, the separate and equal station to which the laws of nature and of nature's God entitle them, a decent respect to the opinions of mankind requires that they should declare the causes which impel them to the separation. We hold these truths to be self-evident, that all men are created equal; that they are endowed by their Creator with certain unalienable rights; that among these, are life, liberty, and the pursuit of happiness. That, to secure these rights, governments are instituted among men, deriving their just powers from the consent of the governed; that, *when- ever any form of government becomes destructive of*

Lower case a to z, 12½ ems

ABCDEFGHIJKLMNOPQRSTUVWXYZ

1234567890

12 POINT NO 54 °

WHEN, in the course of human events, it becomes necessary for one people to dissolve the political bands which have connected them with another, and to assume, among the powers of the earth, the separate and equal station to which the laws of nature and of nature's God entitle them, a decent respect to the opinions of mankind requires that they should declare the causes which impel them to the separation. We hold these truths to be self-evident, that all men are created equal; that they are endowed by their Creator with certain unalienable rights; that among these, are life, liberty, and the pursuit of happiness. That, to secure these rights, *governments are instituted among men, deriving, their*

Lower case a to z, 12¾ ems

ABCDEFGHIJKLMNOPQRSTUVWXYZ
1234567890

12 POINT SELF SPACING NO 31½ °

Unit of measure, 7 to Pica

WHEN, in the course of human events, it becomes necessary for one people to dissolve the political bands which have connected them with another, and to assume, among the powers of the earth, the separate and equal station to which the laws of nature and of nature's God entitle them, a decent respect to the opinions of mankind requires that they should declare the causes which impel them to the separation. We hold these truths to be self-evident, that all men are created equal; that they are endowed by their Creator with certain unalienable rights; that among these, are life, liberty, and the pursuit of happiness. That, to secure these rights, governments are instituted among men, deriving their just powers from the *consent of the governed; that, whenever any form*

Lower case a to z, 13¼ ems

ABCDEFGHIJKLMNOPQRSTUVWXYZ
1234567890

12 POINT NO 64 ϵ

WHEN, in the course of human events, it becomes necessary for one people to dissolve the political bands which have connected them with another, and to assume, among the powers of the earth, the separate and equal station to which the laws of nature and of nature's God entitle them, a decent respect to the opinions of mankind requires that they should declare the causes which impel them to the separation. We hold these truths to be self-evident, that all men are created equal; that they are endowed by their Creator with certain unalienable rights; that among these, are life, liberty, and the pursuit of happiness. That, to secure these rights, governments are instituted among men, deriving their just powers from the *consent of the governed; that, whenever any form*

Lower case a to z, 13 $\frac{2}{3}$ ems

ABCDEFGHIJKLMNOPQRSTUVWXYZ
1234567890

12 POINT NO 47 ϵ

WHEN, in the course of human events, it becomes necessary for one people to dissolve the political bands which have connected them with another, and to assume, among the powers of the earth, the separate and equal station to which the laws of nature and of nature's God entitle them, a decent respect to the opinions of mankind requires that they should declare the causes which impel them to the separation. We hold these truths to be self-evident, that all men are created equal; that they are endowed by their Creator with certain unalienable rights; that among these, are life, liberty, and the pursuit of happiness. That, to secure these rights, governments are instituted among men, deriving their just powers *from the consent of the governed; that, whenever*

Lower case a to z, 13 $\frac{2}{3}$ ems

ABCDEFGHIJKLMNOPQRSTUVWXYZ
1234567890

14 POINT NO 64 ^ε

WHEN, in the course of human events, it becomes necessary for one people to dissolve the political bands which have connected them with another, and to assume, among the powers of the earth, the separate and equal station to which the laws of nature and of nature's God entitle them, a decent respect to the opinions of mankind requires that they should declare the causes which impel them to the separation. We hold these truths to be self-evident, that all men are created equal; that they are endowed by their Creator with certain unalienable rights; that among *these, are life, liberty, and the pursuit of happiness*

Lower case a to z, 11 $\frac{2}{3}$ ems

ABCDEFGHIJKLMN O PQRSTU VWXYZ

1234567890

14 POINT NO 60 ^A

WHEN, in the course of human events, it becomes necessary for one people to dissolve the political bands which have connected them with another, and to assume, among the powers of the earth, the separate and equal station to which the laws of nature and of nature's God entitle them, a decent respect to the opinions of mankind requires that they should declare the causes which impel them to the separation. We hold these truths to be self-evident, that all men are created equal; that they are endowed by their Creator with certain unalienable rights; that among *these are life*

Lower case a to z, 12 $\frac{1}{4}$ ems

ABCDEFGHIJKLMN O PQRSTU VWX

1234567890

MODERN ROMANS SHOWN BY SERIES

MODERN ROMAN SERIES No 46

5 POINT NO 46

WHEN, in the course of human events, it becomes necessary for one people to dissolve the political bands which have connected them with another, and to assume, among the powers of the earth, the separate and equal station to which the laws of nature and of nature's God entitle them, a decent respect to the opinions of mankind requires that they should declare the causes which impel them to the separation. We hold these truths to be self-evident, that all men are created equal; that they are endowed by their Creator with certain unalienable rights; that among these, are life, liberty, and the pursuit of happiness. That, to secure these rights, governments are instituted among men, deriving their just powers from the consent of the gov-

Lower case a to z, 17 ems

ABCDEFGHIJKLMN OPQRSTUVWXYZ
1234567890

5½ POINT NO 46

WHEN, in the course of human events, it becomes necessary for one people to dissolve the political bands which have connected them with another, and to assume, among the powers of the earth, the separate and equal station to which the laws of nature and of nature's God entitle them, a decent respect to the opinions of mankind requires that they should declare the causes which impel them to the separation. We hold these truths to be self-evident, that all men are created equal; that they are endowed by their Creator with certain unalienable rights; that among these, are *life, liberty, and the pursuit of happiness.* *That, to secure these rights, governments are*

Lower case a to z, 16 ems

ABCDEFGHIJKLMN OPQRSTUVWXYZ
1234567890

6 POINT NO 46

WHEN, in the course of human events, it becomes necessary for one people to dissolve the political bands which have connected them with another, and to assume, among the powers of the earth, the separate and equal station to which the laws of nature and of nature's God entitle them, a decent respect to the opinions of mankind requires that they should declare the causes which impel them to the separation. We hold these truths to be self-evident, that all men are created equal; that they are endowed by their Creator with certain unalienable rights; that among these, are life, liberty, and the pursuit of happiness. That, to secure these rights, governments are instituted among men, deriving their just powers from the consent of the governed; that, whenever any form of government becomes destructive of these ends, it is the right of the people to alter or to abolish it, and to institute a new government, laying its foundation on such principles, and organizing its powers in such form, as to them shall seem most likely to effect their safety and happiness. *Prudence, indeed, will dictate that governments long established, should not be changed for light and transient causes; and, accordingly, all experi-*

Lower case a to z, 16¾ ems

ABCDEFGHIJKLMN OPQRSTUVWXYZ
1234567890

7 POINT NO 46

WHEN, in the course of human events, it becomes necessary for one people to dissolve the political bands which have connected them with another, and to assume, among the powers of the earth, the separate and equal station to which the laws of nature and of nature's God entitle them, a decent respect to the opinions of mankind requires that they should declare the causes which impel them to the separation. We hold these truths to be self-evident, that all men are created equal; that they are endowed by their Creator with certain unalienable rights; that among these, are life, liberty, and the pursuit of happiness. That, to secure these rights, governments are instituted among men, deriving *their just powers from the consent of the governed; that, whenever any form of government becomes destructive of these ends, it is the right of the*

Lower case a to z, 16 ems

ABCDEFGHIJKLMN OPQRSTUVWXYZ
1234567890

8 POINT NO 46

WHEN, in the course of human events, it becomes necessary for one people to dissolve the political bands which have connected them with another, and to assume, among the powers of the earth, the separate and equal station to which the laws of nature and of nature's God entitle them, a decent respect to the opinions of mankind requires that they should declare the causes which impel them to the separation. We hold these truths to be self-evident, that all men are created equal; that they are endowed by their Creator with certain unalienable rights; that among these, are life, liberty, and the pursuit of happiness. That, to secure these rights, governments are instituted among men, deriving their just powers from the consent of the governed; that, whenever any form of government becomes destructive of these ends, it is the right of the people to alter or to abolish it, and to institute a new government, laying its foundation on such principles, and organizing its powers in such form, as to them shall seem most likely to effect their safety and happiness. Prudence, indeed, will dictate that governments long established, should not be changed for light and transient causes; and, accordingly, all experience hath shown, that mankind are more disposed to suffer, while evils are sufferable, *than to right themselves by abolishing the forms to which they are accustomed. But, when a long train of abuses and usurpations, pursuing*

Lower case a to z, 15¼ ems

ABCDEFGHIJKLMNOPQRSTUVWXYZ

1234567890

9 POINT NO 46

WHEN, in the course of human events, it becomes necessary for one people to dissolve the political bands which have connected them with another, and to assume, among the powers of the earth, the separate and equal station to which the laws of nature and of nature's God entitle them, a decent respect to the opinions of mankind requires that they should declare the causes which impel them to the separation. We hold these truths to be self-evident, that all men are created equal; that they are endowed by their Creator with certain unalienable rights; that among these, are life, liberty, and the pursuit of happiness. That, to secure these rights, governments are instituted among men, deriving their just powers from the consent of the governed; that, whenever any form of government becomes destructive of these ends, it is the right of the people to alter or to abolish it, and to institute a new government, laying its foundation on such principles, and organizing its powers in such form, as to them shall seem most likely to effect their safety and happiness. Prudence, indeed, will dictate that governments long established, should not be changed for

Lower case a to z, 15 ems

ABCDEFGHIJKLMNOPQRSTUVWXYZ

1234567890

MODERN ROMAN SERIES No 47

5½ POINT NO 47

WHEN, in the course of human events, it becomes necessary for one people to dissolve the political bands which have connected them with another, and to assume, among the powers of the earth, the separate and equal station to which the laws of nature and of nature's God entitle them, a decent respect to the opinions of mankind requires that they should declare the causes which impel them to the separation. We hold these truths to be self-evident, that all men are created equal; that they are endowed by their Creator with certain unalienable rights; that among these, are life, liberty, and the pursuit of happiness. That, to secure these rights, governments are instituted among men, deriving their just powers from the consent of the governed; that, whenever any form of government becomes destructive of these ends, it is the right of the people to alter or to abolish it, and to institute a new government, laying its foundations on such principles, and organizing its powers in such form, as to them shall seem most likely to effect their safety and happiness. Prudence, indeed, will dictate that governments long established, should not be changed for light and transient causes; and, accordingly, all experience hath shown, that mankind are more disposed to suffer, while evils are sufferable, than to right themselves by abolishing the forms to which they are accustomed. But, when a long train of abuses and usurpations, pursuing invariably the same object, evinces a design to reduce them under absolute despotism, it is their right, it is their duty, to throw off such government, and to provide new guards for their future security. Such has been the patient sufferance of these colonies, and such is now the necessity which constrains them to alter their former systems of government. *The history of the present king of Great Britain is a history of re-*

Lower case a to z, 15 ems

ABCDEFGHIJKLMNOPQRSTUVWXYZ
1234567890

6 POINT NO 47

WHEN, in the course of human events, it becomes necessary for one people to dissolve the political bands which have connected them with another, and to assume, among the powers of the earth, the separate and equal station to which the laws of nature and of nature's God entitle them, a decent respect to the opinions of mankind requires that they should declare the causes which impel them to the separation. We hold these truths to be self-evident, that all men are created equal; that they are endowed by their Creator with certain unalienable rights; that among these, are life, liberty, and the pursuit of happiness. That, to secure these rights, governments are instituted among men, deriving their just powers from the consent of the governed; that, whenever any form of government becomes destructive of these ends, it is the right of the people to alter or to abolish it, and to institute a new government, laying its foundation on such principles, and organizing its powers in such form, as to them shall seem most likely to effect their safety and happiness. Prudence, indeed, will dictate that governments long established, should not be changed for light and transient causes; and, accordingly, all experience hath shown, that mankind are more disposed to suffer, while evils are sufferable, than to right themselves by abolishing the forms to which they are accustomed. *But, when a long train of abuses and usurpations, pursuing invariably the same object, evinces a design to reduce them under absolute despotism, it is their right, it*

Lower case a to z, 15½ ems

ABCDEFGHIJKLMNOPQRSTUVWXYZ
1234567890

7 POINT NO 47

WHEN, in the course of human events, it becomes necessary for one people to dissolve the political bands which have connected them with another, and to assume, among the powers of the earth, the separate and equal station to which the laws of nature and of nature's God entitle them, a decent respect to the opinions of mankind requires that they should declare the causes which impel them to the separation. We hold these truths to be self-evident, that all men are created equal; that they are endowed by their Creator with certain unalienable rights; that among these, are life, liberty, and the pursuit of happiness. That, to secure these rights, governments are instituted among men, deriving their just powers from the consent of the governed; that, whenever any form of government becomes destructive of these ends, it is the right of the people to alter or to abolish it, and to institute a new government, laying its foundation on such principles, and organizing its powers in such form, as to them shall seem most likely to effect their safety and happiness. *Prudence, indeed, will dictate that governments long established, should not be changed for light and transient causes;*

Lower case a to z, 14½ ems

ABCDEFGHIJKLMNOPQRSTUVWXYZ
1234567890

8 POINT NO 47

WHEN, in the course of human events, it becomes necessary for one people to dissolve the political bands which have connected them with another, and to assume, among the powers of the earth, the separate and equal station to which the laws of nature and of nature's God entitle them, a decent respect to the opinions of mankind requires that they should declare the causes which impel them to the separation. We hold these truths to be self-evident, that all men are created equal; that they are endowed by their Creator with certain unalienable rights; that among these, are life, liberty, and the pursuit of happiness. That, to secure these rights, governments are instituted among men, deriving their just powers from the consent of the governed; that, whenever any form of *government becomes destructive of these ends, it is the right of the people to alter or to abolish it, and to institute a new government, laying its foundation*

Lower case a to z, 13½ ems

ABCDEFGHIJKLMNOPQRSTUVWXYZ

1234567890

9 POINT NO 47

WHEN, in the course of human events, it becomes necessary for one people to dissolve the political bands which have connected them with another, and to assume, among the powers of the earth, the separate and equal station to which the laws of nature and of nature's God entitle them, a decent respect to the opinions of mankind requires that they should declare the causes which impel them to the separation. We hold these truths to be self-evident, that all men are created equal; that they are endowed by their Creator with certain unalienable rights; that among these, are life, liberty, and the pursuit of happiness. That, to secure these rights, governments *are instituted among men, deriving their just powers from the consent of the governed; that, whenever any form of government becomes destructive*

Lower case a to z, 13 ems

ABCDEFGHIJKLMNOPQRSTUVWXYZ

1234567890

10 POINT NO 47

WHEN, in the course of human events, it becomes necessary for one people to dissolve the political bands which have connected them with another, and to assume, among the powers of the earth, the separate and equal station to which the laws of nature and of nature's God entitle them, a decent respect to the opinions of mankind requires that they should declare the causes which impel them to the separation. We hold these truths to be self-evident, that all men are created equal; that they are endowed by their Creator with certain *unalienable rights; that among these, are life, liberty, and the pursuit of happiness. That, to secure these rights, governments*

Lower case a to z, 13 ems

ABCDEFGHIJKLMNOPQRSTUVWXYZ

1234567890

11 POINT NO 47

WHEN, in the course of human events, it becomes necessary for one people to dissolve the political bands which have connected them with another, and to assume, among the powers of the earth, the separate and equal station to which the laws of nature and of nature's God entitle them, a decent respect to the opinions of mankind requires that they should declare the causes which impel them to the separation. We hold these truths to be self-evident, that all men are created equal; that they are endowed by their Creator with certain unalienable rights; that among these, are life, liberty, and the pursuit of happiness. That, to secure these rights, governments are instituted among men, deriving their just powers from the consent of the governed; that, whenever any form of government *becomes destructive of these ends, it is the right of the people to alter or to abolish it, and to institute a new*

Lower case a to z, 13¼ ems

ABCDEFGHIJKLMNOPQRSTUVWXYZ
1234567890

12 POINT NO 47

WHEN, in the course of human events, it becomes necessary for one people to dissolve the political bands which have connected them with another, and to assume, among the powers of the earth, the separate and equal station to which the laws of nature and of nature's God entitle them, a decent respect to the opinions of mankind requires that they should declare the causes which impel them to the separation. We hold these truths to be self-evident, that all men are created equal; that they are endowed by their Creator with certain unalienable rights; that among these, are life, liberty, and the pursuit of happiness. That, to secure these rights, governments *are instituted among men, deriving their just powers from the consent of the governed; that, whenever any*

Lower case a to z, 13⅔ ems

ABCDEFGHIJKLMNOPQRSTUVWXYZ
1234567890

MODERN ROMAN SERIES No 53

5½ POINT NO 53

WHEN, in the course of human events, it becomes necessary for one people to dissolve the political bands which have connected them with another, and to assume, among the powers of the earth, the separate and equal station to which the laws of nature and of nature's God entitle them, a decent respect to the opinions of mankind requires that they should declare the causes which impel them to the separation. We hold these truths to be self-evident, that all men are created equal; that they are endowed by their Creator with certain un-

Lower case a to z, 16¼ ems

ABCDEFGHIJKLMN OPQRSTUVWXYZ
1234567890

6 POINT NO 53

WHEN, in the course of human events, it becomes necessary for one people to dissolve the political bands which have connected them with another, and to assume, among the powers of the earth, the separate and equal station to which the laws of nature and of nature's God entitle them, a decent respect to the opinions of mankind requires that they should declare the causes which impel *them to the separation. We hold these truths to be self-evident, that all men are*

Lower case a to z, 15⅞ ems

ABCDEFGHIJKLMN OPQRSTUVWXYZ
1234567890

7 POINT NO 53

WHEN, in the course of human events, it becomes necessary for one people to dissolve the political bands which have connected them with another, and to assume, among the powers of the earth, the separate and equal station to which the laws of nature and of nature's God entitle them, a decent respect to the opinions of mankind requires that they should declare the causes which impel them to the separation. We hold these truths to be self-evident, that all men are created equal; that they are endowed by their Creator with certain unalienable rights; that among these, are life, liberty, *and the pursuit of happiness. That, to secure these rights, governments are instituted among men, deriving their just powers from the consent*

Lower case a to z, 15½ ems

ABCDEFGHIJKLMN OPQRSTUVWXYZ
1234567890

8 POINT NO 53

WHEN, in the course of human events, it becomes necessary for one people to dissolve the political bands which have connected them with another, and to assume, among the powers of the earth, the separate and equal station to which the laws of nature and of nature's God entitle them, a decent respect to the opinions of mankind requires that they should declare the causes which impel them to the separation. *We hold these truths to be self-evident, that all men are created equal; that they are endowed by their Creator with certain unalien-*

Lower case a to z, 14⅔ ems

ABCDEFGHIJKLMN OPQRSTUVWXYZ
1234567890

9 POINT NO 53

WHEN, in the course of human events, it becomes necessary for one people to dissolve the political bands which have connected them with another, and to assume, among the powers of the earth, the separate and equal station to which the laws of nature and of nature's God entitle them, a decent respect to the opinions of mankind *requires that they should declare the causes which impel them to the separation. We hold these truths to be self-evident, that all men are*

Lower case a to z, 13 ems

ABCDEFGHIJKLMN OPQRSTUVWXYZ
1234567890

MODERN ROMAN SERIES No 50

6 POINT NO 50

WHEN, in the course of human events, it becomes necessary for one people to dissolve the political bands which have connected them with another, and to assume, among the powers of the earth, the separate and equal station to which the laws of nature and of nature's God entitle them, a decent respect to the opinions of mankind requires that they should declare the causes which impel them to the separation. We hold these truths to be self-evident, that all men are created equal; that they are endowed by their Creator with certain unalienable rights; that among these, are life, liberty, and the pursuit of happiness. That, to secure these rights, governments are instituted among men, deriving their just powers from the consent of the governed; that, whenever any form of government becomes destructive of these ends, it is the right of the people to alter or to abolish it, and to institute a new government, laying its foundation on such principles, and organizing its powers in such form, as to them shall seem most likely to effect their safety and happiness. Prudence, indeed, will dictate that governments long established, should not be *changed for light and transient causes; and, accordingly, all experience hath shown, that mankind are more disposed to suffer, while evils are sufferable, than to*

Lower case a to z, 15¾ ems

ABCDEFGHIJKLMNOPQRSTUVWXYZ

1234567890

7 POINT NO 50

WHEN, in the course of human events, it becomes necessary for one people to dissolve the political bands which have connected them with another, and to assume, among the powers of the earth, the separate and equal station to which the laws of nature and of nature's God entitle them, a decent respect to the opinions of mankind requires that they should declare the causes which impel them to the separation. We hold these truths to be self-evident, that all men are created equal; that they are endowed by their Creator with certain unalienable rights; that among these, are life, liberty, and the pursuit of happiness. That, to secure these rights, governments are instituted among men, deriving their just powers from the consent of the governed; that, whenever any form of government becomes destructive *of these ends, it is the right of the people to alter or to abolish it, and to institute a new government, laying its foundation on such principles, and*

Lower case a to z, 14¾ ems

ABCDEFGHIJKLMNOPQRSTUVWXYZ

1234567890

8 POINT NO 50

WHEN, in the course of human events, it becomes necessary for one people to dissolve the political bands which have connected them with another, and to assume, among the powers of the earth, the separate and equal station to which the laws of nature and of nature's God entitle them, a decent respect to the opinions of mankind requires that they should declare the causes which impel them to the separation. We hold these truths to be self-evident, that all men are created equal; that they are endowed by their Creator with certain unalienable rights; that among these, are life, liberty, and the pursuit of happiness. *That, to secure these rights, governments are instituted among men, deriving their just powers from the consent of the governed;*

Lower case a to z, 14 ems

ABCDEFGHIJKLMNOPQRSTUVWXYZ

1234567890

9 POINT NO 50

WHEN, in the course of human events, it becomes necessary for one people to dissolve the political bands which have connected them with another, and to assume, among the powers of the earth, the separate and equal station to which the laws of nature and of nature's God entitle them, a decent respect to the opinions of mankind requires that they should declare the causes which impel them to the separation. We hold these truths to be self-evident, that all men are created equal; that they are endowed by their Creator with certain unalienable rights; that among these, are life, liberty, and the pursuit of happiness. That, to secure these rights, governments are instituted among men, deriving their just powers from the consent of the governed; that, whenever any form of government becomes destructive of these ends, it is the right of the people to alter or to abolish it, and to institute a new government, laying its foundation on such principles, and organizing its powers in such form, as to them shall seem most likely to effect their safety and happiness. Prudence, indeed, will dictate *that governments long established, should not be changed for light and transient causes; and, accordingly, all experience hath shown,*

Lower case a to z, 14 ems

ABCDEFGHIJKLMNOPQRSTUVWXYZ
1234567890

10 POINT NO 50

WHEN, in the course of human events, it becomes necessary for one people to dissolve the political bands which have connected them with another, and to assume, among the powers of the earth, the separate and equal station to which the laws of nature and of nature's God entitle them, a decent respect to the opinions of mankind requires that they should declare the causes which impel them to the separation. We hold these truths to be self-evident, that all men are created equal; that they are endowed by their Creator with certain unalienable rights; that among these, are life, liberty, and the pursuit of happiness. That, to secure these rights, governments are instituted among men, deriving their just powers from the consent of the governed; that, whenever any form of government becomes destructive of these ends, it is the right of the *people to alter or to abolish it, and to institute a new government, laying its foundation on such principles, and*

Lower case a to z, 13¾ ems

ABCDEFGHIJKLMNOPQRSTUVWXYZ
1234567890

LARGE-FACE SERIES No 54

6 POINT No 54

WHEN, in the course of human events, it becomes necessary for one people to dissolve the political bands which have connected them with another, and to assume, among the powers of the earth, the separate and equal station to which the laws of nature and of nature's God entitle them, a decent respect to the opinions of mankind requires that they should declare the causes which impel them to the separation. We hold these truths to be self-evident, that all men are created equal; that they are endowed by their Creator with certain unalienable rights; that among these, are life, liberty, and the pursuit of happiness. That, to secure these rights, governments are instituted among men, deriving their just powers from the consent of the governed; *that, whenever any form of government becomes destructive of these ends, it is the right of the people to alter or to abolish it, and to institute a new government, laying its foundation on*

Lower case a to z, 15 $\frac{1}{2}$ ems

ABCDEFGHIJKLMNOPQRSTUVWXYZ

1234567890

7 POINT No 54

WHEN, in the course of human events, it becomes necessary for one people to dissolve the political bands which have connected them with another, and to assume, among the powers of the earth, the separate and equal station to which the laws of nature and of nature's God entitle them, a decent respect to the opinions of mankind requires that they should declare the causes which impel them to the separation. We hold these truths to be self-evident, that all men are created equal; that they are endowed by their Creator with certain unalienable rights; that among these, are life, liberty, and the pursuit of happiness. *That, to secure these rights, governments are instituted among men, deriving their just powers from the consent of the governed;*

Lower case a to z, 15 ems

ABCDEFGHIJKLMNOPQRSTUVWXYZ

1234567890

8 POINT No 54

WHEN, in the course of human events, it becomes necessary for one people to dissolve the political bands which have connected them with another, and to assume, among the powers of the earth, the separate and equal station to which the laws of nature and of nature's God entitle them, a decent respect to the opinions of mankind requires that they should declare the causes which impel them to the separation. We hold these truths to be self-evident, that all men are *created equal; that they are endowed by their Creator with certain unalienable rights; that among these are life, liberty, and the pursuit of happiness. That,*

Lower case a to z, 14 $\frac{1}{4}$ ems

ABCDEFGHIJKLMNOPQRSTUVWXYZ

1234567890

9 POINT No 54

WHEN, in the course of human events, it becomes necessary for one people to dissolve the political bands which have connected them with another, and to assume, among the powers of the earth, the separate and equal station to which the laws of nature and of nature's God entitle them, a decent respect to the opinions of mankind requires that they should declare the causes which impel *them to the separation. We hold these truths to be self-evident, that all men are created equal; that they are endowed by their Creator with cer-*

Lower case a to z, 13 ems

ABCDEFGHIJKLMNOPQRSTUVWXYZ

1234567890

10 POINT NO 54

WHEN, in the course of human events, it becomes necessary for one people to dissolve the political bands which have connected them with another, and to assume, among the powers of the earth, the separate and equal station to which the laws of nature and of nature's God entitle them, a decent respect to the opinions of mankind requires that they should declare the causes which impel them to the separation. We hold these truths to be self-evident, that all men are created equal; that they are endowed by their Creator with certain unalienable rights; *that among these, are life, liberty, and the pursuit of happiness. That, to secure these rights, governments are instituted among*

Lower case a to z, 12 3/5 ems

ABCDEFGHIJKLMNOPQRSTUVWXYZ
1234567890

11 POINT NO 54

WHEN, in the course of human events, it becomes necessary for one people to dissolve the political bands which have connected them with another, and to assume, among the powers of the earth, the separate and equal station to which the laws of nature and of nature's God entitle them, a decent respect to the opinions of mankind requires that they should declare the causes which impel them to the separation. We hold these truths to be self-evident, that *all men are created equal; that they are endowed by their Creator with certain unalienable rights; that, among these are*

Lower case a to z, 12 1/4 ems

ABCDEFGHIJKLMNOPQRSTUVWXYZ
1234567890

12 POINT NO 54

WHEN, in the course of human events, it becomes necessary for one people to dissolve the political bands which connected them with another, and to assume, among the powers of the earth, the separate and equal station to which the laws of nature and of nature's God entitle them, a decent respect to the opinions of mankind requires that they should *declare the causes which impel them to the separation. We hold these truths to be self-evident, that all men are*

Lower case a to z, 12 3/4 ems

ABCDEFGHIJKLMNOPQRSTUVWXYZ
1234567890

INLAND SERIES No 56

5½ POINT NO 56

WHEN, in the course of human events, it becomes necessary for one people to dissolve the political bands which have connected them with another, and to assume, among the powers of the earth, the separate and equal station to which the laws of nature and of nature's God entitle them, a decent respect to the opinions of mankind requires that they should declare the causes which impel them to the separation. We hold these truths to be self-evident, that all men are created equal; that they are endowed by their Creator with certain unalienable rights; that among these, are life, liberty, and the pursuit of happiness. That, to secure these rights, governments are instituted among men, deriving their just powers from the consent of the governed; that, whenever any form of government becomes destructive of these ends, it is the right of the people to alter or to abolish it, and to institute a new government, laying its foundation on such principles, and organizing its powers in such form, as to them shall seem most likely to effect their safety and happiness. Prudence, indeed, will dictate that governments long established, should not be changed for light and transient causes; and, accordingly, all experience hath shown, that mankind are more disposed to suffer, while evils are sufferable, than to right themselves by abolishing the forms to which they are accustomed. *But, when a long train of abuses and usurpations, pursuing invariably the same object, evinces a design to reduce them*

Lower case a to z, 17½ ems

ABCDEFGHIJKLMNOPQRSTUVWXYZ
1234567890

6 POINT NO 56

WHEN, in the course of human events, it becomes necessary for one people to dissolve the political bands which have connected them with another, and to assume, among the powers of the earth, the separate and equal station to which the laws of nature and of nature's God entitle them, a decent respect to the opinions of mankind requires that they should declare the causes which impel them to the separation. We hold these truths to be self-evident, that all men are created equal; that they are endowed by their Creator with certain unalienable rights; that among these, are life, liberty, and the pursuit of happiness. That, to secure these rights, governments are instituted among men, deriving their just powers from the consent of the governed; that, whenever any form of government becomes destructive of these ends, it is the right of the people to alter or to abolish it, and to institute a new government, laying its foundation on such principles, and organizing its powers in such form, as to them shall seem most likely to effect their safety and happiness. *Prudence, indeed, will dictate that governments long established, should not be changed for light and transient causes; and, accordingly, all expe-*

Lower case a to z, 18 ems

ABCDEFGHIJKLMNOPQRSTUVWXYZ
1234567890

7 POINT NO 56

WHEN, in the course of human events, it becomes necessary for one people to dissolve the political bands which have connected them with another, and to assume, among the powers of the earth, the separate and equal station to which the laws of nature and of nature's God entitle them, a decent respect to the opinions of mankind requires that they should declare the causes which impel them to the separation. We hold these truths to be self-evident, that all men are created equal; that they are endowed by their Creator with certain unalienable rights; that among these, are life, liberty, and the pursuit of happiness. That, to secure these rights, governments are instituted among men, deriving their just powers from the consent of the governed; that, *whenever any form of government becomes destructive of these ends, it is the right of the people to alter or to abolish it, and to institute a new*

Lower case a to z, 17 ems

ABCDEFGHIJKLMNOPQRSTUVWXYZ
1234567890

8 POINT NO 56

WHEN, in the course of human events, it becomes necessary for one people to dissolve the political bands which have connected them with another, and to assume, among the powers of the earth, the separate and equal station to which the laws of nature and of nature's God entitle them, a decent respect to the opinions of mankind requires that they should declare the causes which impel them to the separation. We hold these truths to be self-evident, that all men are created equal; that they are endowed by their Creator with certain unalienable rights; that among these, are life, liberty, and the pursuit of happiness. That, to *secure these rights, governments are instituted among men, deriving their just powers from the consent of the governed; that,*

Lower case a to z, 15¾ ems

ABCDEFGHIJKLMNOPQRSTUVWXYZ
1234567890

9 POINT NO 56

WHEN, in the course of human events, it becomes necessary for one people to dissolve the political bands which have connected them with another, and to assume, among the powers of the earth, the separate and equal station to which the laws of nature and of nature's God entitle them, a decent respect to the opinions of mankind requires that they should declare the causes which impel them to the separation. We hold these truths to be self-evident, that all men are created equal; that they are endowed by their Creator with certain *unalienable rights; that among these, are life, liberty, and the pursuit of happiness. That, to secure these rights, governments*

Lower case a to z, 15 ems

ABCDEFGHIJKLMNOPQRSTUVWXYZ
1234567890

10 POINT NO 56

WHEN, in the course of human events, it becomes necessary for one people to dissolve the political bands which have connected them with another, and to assume, among the powers of the earth, the separate and equal station to which the laws of nature and of nature's God entitle them, a decent respect to the opinions of mankind requires that they should declare the causes which impel them to the separation. We hold these truths to be self-evident, that *all men are created equal; that they are endowed by their Creator with certain unalienable rights; that among these,*

Lower case a to z, 13¾ ems

ABCDEFGHIJKLMNOPQRSTUVWXYZ
1234567890

MODERN ROMAN SERIES No 57

5 POINT NO 57 ^ε

WHEN, in the course of human events, it becomes necessary for one people to dissolve the political bands which have connected them with another, and to assume, among the powers of the earth, the separate and equal station to which the laws of nature and of nature's God entitle them, a decent respect to the opinions of mankind requires that they should declare the causes which impel them to the separation. We hold these truths to be self-evident, that all men are created equal; that they are endowed by their Creator with certain unalienable rights; that among these, are life, liberty, and pursuit of happiness. That, to secure these rights, governments are instituted among men, deriving their just powers from the consent of the governed; that, whenever any form of government becomes destruc-

Lower case a to z, 17 ems

ABCDEFGHIJKLMN OPQRSTUVWXYZ
1234567890

^ε 5½ POINT NO 57

WHEN, in the course of human events, it becomes necessary for one people to dissolve the political bands which have connected them with another, and to assume, among the powers of the earth, the separate and equal station to which the laws of nature and of nature's God entitle them, a decent respect to the opinions of mankind requires that they should declare the causes which impel them to the separation. We hold these truths to be self-evident, that all men are created equal; that they are endowed by their Creator with certain unalienable rights; that among these, are life, liberty, and the pursuit of happiness. That, to secure these rights, governments are instituted among men, deriving their

Lower case a to z, 16 ems

ABCDEFGHIJKLMN OPQRSTUVWXYZ
1234567890

6 POINT NO 57 ^ο

WHEN, in the course of human events, it becomes necessary for one people to dissolve the political bands which have connected them with another, and to assume, among the powers of the earth, the separate and equal station to which the laws of nature and of nature's God entitle them, a decent respect to the opinions of mankind requires that they should declare the causes which impel them to the separation. We hold these truths to be self-evident, that all men are created equal; that they are endowed by their Creator with certain unalienable rights; that among these, are life, liberty, and the pursuit of happiness. That, to secure these rights, governments are instituted among men, deriving their just powers from the consent of the governed; that, whenever any form of government becomes destructive of these ends, it is the right of the people to alter or to abolish it, and to institute a new government, laying its foundation on such principles, and organizing its powers in such form, as to them shall seem most likely to effect their safety and happiness. Prudence, indeed, will dictate that governments long established, *should not be changed for light and transient causes; and, accordingly, all experience hath shown, that mankind are more disposed to suffer, while evils are*

Lower case a to z, 15¾ ems

ABCDEFGHIJKLMN OPQRSTUVWXYZ
1234567890

7 POINT NO 57 ^ο

WHEN, in the course of human events, it becomes necessary for one people to dissolve the political bands which have connected them with another, and to assume, among the powers of the earth, the separate and equal station to which the laws of nature and of nature's God entitle them, a decent respect to the opinions of mankind requires that they should declare the causes which impel them to the separation. We hold these truths to be self-evident, that all men are created equal; that they are endowed with certain unalienable rights; that among these, are life, liberty, and the pursuit of happiness. That, to secure these rights, governments are instituted among men, deriving their just powers from the consent of the governed; that, whenever any form of government becomes destructive of these ends, it is the right of *the people to alter or to abolish it, and to institute a new government, laying its foundation on such principles, and organizing its powers in*

Lower case a to z, 14¾ ems

ABCDEFGHIJKLMN OPQRSTUVWXYZ
1234567890

8 POINT NO 57

WHEN, in the course of human events, it becomes necessary for one people to dissolve the political bands which have connected them with another, and to assume, among the powers of the earth, the separate and equal station to which the laws of nature and of nature's God entitle them, a decent respect to the opinions of mankind requires that they should declare the causes which impel them to the separation. We hold these truths to be self-evident, that all men are created equal; that they are endowed by their Creator with certain unalienable rights; that among these, are life, liberty, and the pursuit of happiness. That, to secure these rights, governments are instituted among men, deriving *their just powers from the consent of the governed; that, whenever any form of government becomes destructive of these ends,*

Lower case a to z, 14 ems

ABCDEFGHIJKLMNOPQRSTUVWXYZ
1234567890

9 POINT NO 57

WHEN, in the course of human events, it becomes necessary for one people to dissolve the political bands which have connected them with another, and to assume, among the powers of the earth, the separate and equal station to which the laws of nature and of nature's God entitle them, a decent respect to the opinions of mankind requires that they should declare the causes which impel them to the separation. We hold these truths to be self-evident, that all men are created equal; that they are endowed by their Creator with certain unalienable rights; that among these, are *life, liberty, and the pursuit of happiness. That, to secure these rights, governments are instituted among men, deriving their just*

Lower case a to z, 13 $\frac{2}{3}$ ems

ABCDEFGHIJKLMNOPQRSTUVWXYZ
1234567890

10 POINT NO 57

WHEN, in the course of human events, it becomes necessary for one people to dissolve the political bands which have connected them with another, and to assume, among the powers of the earth, the separate and equal station to which the laws of nature and of nature's God entitle them, a decent respect to the opinions of mankind requires that they should declare the causes which impel them to the separation. We hold these truths to be self-evident, that all men are created *equal; that they are endowed by their Creator with certain unalienable rights; that among these, are life, liberty, and*

Lower case a to z, 13 $\frac{1}{4}$ ems

ABCDEFGHIJKLMNOPQRSTUVWXYZ
1234567890

WILSON SERIES No 60

6 POINT No 60

WHEN, in the course of human events, it becomes necessary for one people to dissolve the political bands which have connected them with another, and to assume, among the powers of the earth, the separate and equal station to which the laws of nature and of nature's God entitle them, a decent respect to the opinions of mankind requires that they should declare the causes which impel them to the separation. We hold these truths to be self-evident, that all men are created equal; that they are endowed by their Creator with certain unalienable rights; that among these, are life, liberty, and the pursuit of happiness. That, to secure *these rights, governments are instituted among men, deriving their just powers from the consent of the governed; that, whenever any form of government becomes destruc-*

Lower case a to z, 15½ ems

ABCDEFGHIJKLMNOPQRSTUVWXYZ
1234567890

7 POINT No 60

WHEN, in the course of human events, it becomes necessary for one people to dissolve the political bands which have connected them with another, and to assume, among the powers of the earth, the separate and equal station to which the laws of nature and of nature's God entitle them, a decent respect to the opinions of mankind requires that they should declare the causes which impel them to the separation. We hold these truths to be *self-evident, that all men are created equal; that they are endowed by their Creator with certain unalienable rights; that among these, are life, liberty*

Lower case a to z, 14¾ ems

ABCDEFGHIJKLMNOPQRSTUVWXYZ
1234567890

8 POINT No 60

WHEN, in the course of human events, it becomes necessary for one people to dissolve the political bands which have connected them with another, and to assume, among the powers of the earth, the separate and equal station to which the laws of nature and of nature's God entitle them, a decent respect to the opinions of mankind requires that they should declare the causes which impel them to the separation. *We hold these truths to be self-evident, that all men are created equal; that they are endowed by their Creator with certain unalienable*

Lower case a to z, 13 ems

ABCDEFGHIJKLMNOPQRSTUVWXYZ
1234567890

9 POINT No 60

WHEN, in the course of human events, it becomes necessary for one people to dissolve the political bands which have connected them with another, and to assume, among the powers of the earth, the separate and equal station to which the laws of nature and of nature's God entitle them, a decent respect to the opinions of mankind *requires that they should declare the causes which impel them to the separation. We hold these truths to be self-evident, that all men are*

Lower case a to z, 12½ ems

ABCDEFGHIJKLMNOPQRSTUVWXYZ
1234567890

10 POINT No 60

WHEN, in the course of human events, it becomes necessary for one people to dissolve the political bands which have connected them with another, and to assume, among the powers of the earth, the separate and equal station to which the laws of nature and of nature's God entitle them, a decent respect to the opinions of mankind requires that they should declare the causes which impel them to the separation. We hold these truths to be self-evident, that all men are created *equal; that they are endowed by their Creator with certain unalienable rights; that among these, are life, liberty, and the*

Lower case a to z, 12 $\frac{2}{3}$ ems

ABCDEFGHIJKLMNOPQRSTUVWXYZ
1234567890

11 POINT No 60

WHEN, in the course of human events, it becomes necessary for one people to dissolve the political bands which have connected them with another, and to assume, among the powers of the earth, the separate and equal station to which the laws of nature and of nature's God entitle them, a decent respect to the opinions of mankind requires that they should declare the causes which impel them to the separation. We hold these truths to be self-evident, that all men are created *equal; that they are endowed by their Creator with certain*

Lower case a to z, 11 $\frac{1}{2}$ ems

ABCDEFGHIJKLMNOPQRSTUVWXYZ
1234567890

12 POINT No 60

WHEN, in the course of human events, it becomes necessary for one people to dissolve the political bands which have connected them with another, and to assume, among the powers of the earth, the separate and equal station to which the laws of nature and of nature's God entitle them, a decent respect to the opinions of mankind requires that they should declare the causes which impel them to the separation. We hold these truths to be self-evident, that all men

Lower case a to z, 12 $\frac{1}{4}$ ems

ABCDEFGHIJKLMNOPQRSTUVWXYZ
1234567890

14 POINT NO 60

WHEN, in the course of human events, it becomes necessary for one people to dissolve the political bands which have connected them with another, and to assume, among the powers of the earth, the separate and equal station to which the laws of nature and of nature's God entitle them, a decent respect to the opinions of mankind requires that they should declare the causes that impel them to the separation. We hold these truths to be self-evident, that all men are *created equal; that they are endowed by their Creator with certain unalienable rights; that*

Lower case a to z, 12¼ ems

ABCDEFGHIJKLMNOPQRSTUVWXYZ
1234567890

18 POINT NO 60

WHEN, in the course of all human events, it becomes necessary for one people to dissolve the political bands which have connected them with another, and to assume, among the powers of the earth, the separate and equal station to which the laws of nature and of nature's God entitle them, a decent respect to the opinions of mankind requires that they

Lower case a to z, 12½ ems

ABCDEFGHIJKLMNOPQRSTUVWXYZ
1234567890

AMERICAN PRESS ASSOCIATION SERIES No 61

6 POINT NO 61

WHEN, in the course of human events, it becomes necessary for one people to dissolve the political bands which have connected them with another, and to assume, among the powers of the earth, the separate and equal station to which the laws of nature and of nature's God entitle them, a decent respect to the opinions of mankind requires that they should declare the causes which impel them to the separation. We hold these truths to be self-evident, that all men are created equal; that they are endowed by their Creator with certain unalienable rights; that among these, are life, liberty, and the pursuit of happiness. That, to secure *these rights, governments are instituted among men, deriving their just powers from the consent of the governed; that, whenever any form of government becomes*

Lower case a to z, 16 $\frac{2}{3}$ ems

ABCDEFGHIJKLMNOPQRSTUVWXYZ

1234567890

7 POINT NO 61

WHEN, in the course of human events, it becomes necessary for one people to dissolve the political bands which have connected them with another, and to assume, among the powers of the earth, the separate and equal station to which the laws of nature and of nature's God entitle them, a decent respect to the opinions of mankind requires that they should declare the causes which impel them to the separation. We hold these truths to be *self-evident, that all men are created equal; that they are endowed by their Creator with certain unalienable rights; that among these, are life,*

Lower case a to z, 15 $\frac{2}{3}$ ems

ABCDEFGHIJKLMNOPQRSTUVWXYZ

1234567890

8 POINT NO 61

WHEN, in the course of human events, it becomes necessary for one people to dissolve the political bands which have connected them with another, and to assume, among the powers of the earth, the separate and equal station to which the laws of nature and of nature's God entitle them, a decent respect to the opinions of mankind requires that they should declare the causes which impel them to the separation. *We hold these truths to be self-evident, that all men are created equal; that they are endowed by their Creator with certain unalienable*

Lower case a to z, 14 $\frac{1}{2}$ ems

ABCDEFGHIJKLMNOPQRSTUVWXYZ

1234567890

9 POINT NO 61

WHEN, in the course of human events, it becomes necessary for one people to dissolve the political bands which have connected them with another, and to assume, among the powers of the earth, the separate and equal station to which the laws of nature and of nature's God entitle them, a decent respect to the opinions of mankind requires that they should declare the causes which impel them to the separation. *We hold these*

Lower case a to z, 14 $\frac{1}{4}$ ems

ABCDEFGHIJKLMNOPQRSTUVWXYZ

1234567890

MODERN ROMAN SERIES No 64

8 POINT NO 64

WHEN, in the course of human events, it becomes necessary for one people to dissolve the political bands which have connected them with another, and to assume, among the powers of the earth, the separate and equal station to which the laws of nature and of nature's God entitle them, a decent respect to the opinions of mankind requires that they should declare the causes which impel them to the separation. We hold these truths to be self-evident, that all men are created equal; that they are endowed by their Creator with certain unalienable rights: that among these are life, liberty, and the pursuit of happiness. That, to secure these rights, governments are instituted among men, deriving their just powers from the consent of the governed; that, whenever any form of government becomes destructive of *these ends, it is the right of the people to alter or to abolish it, and to institute a new government, laying its foundation on such principles, and*

Lower case a to z, 13½ ems

ABCDEFGHIJKLMNOPQRSTUVWXYZ
1234567890

9 POINT NO 64

WHEN, in the course of human events, it becomes necessary for one people to dissolve the political bands which have connected them with another, and to assume, among the powers of the earth, the separate and equal station to which the laws of nature and of nature's God entitle them, a decent respect to the opinions of mankind requires that they should declare the causes which impel them to the separation. We hold these truths to be self-evident, that all men are created equal; that they are endowed by their Creator with certain unalienable rights; that among these, are life, liberty, and the pursuit of happiness. That, to secure these rights, *governments are instituted among men, deriving their just powers from the consent of the governed; that, whenever any form of government*

Lower case a to z, 13 ems

ABCDEFGHIJKLMNOPQRSTUVWXYZ
1234567890

10 POINT NO 64

WHEN, in the course of human events, it becomes necessary for one people to dissolve the political bands which have connected them with another, and to assume, among the powers of the earth, the separate and equal station to which the laws of nature and of nature's God entitle them, a decent respect to the opinions of mankind requires that they should declare the causes which impel them to the separation. We hold these truths to be self-evident, that all men are created equal; *that they are endowed by their Creator with certain unalienable rights; that among these, are life, liberty, and the pursuit of*

Lower case a to z, 13 ems

ABCDEFGHIJKLMNOPQRSTUVWXYZ
1234567890

11 POINT NO 64

WHEN, in the course of human events, it becomes necessary for one people to dissolve the political bands which have connected them with another, and to assume, among the powers of the earth, the separate and equal station to which the laws of nature and of nature's God entitle them, a decent respect to the opinions of mankind requires that they should declare the causes which impel them to the separation. *We hold these truths to be self-evident, that all men are cre-*

Lower case a to z, 13 $\frac{2}{3}$ ems

ABCDEFGHIJKLMNOPQRSTUVWXYZ
1234567890

12 POINT NO 64

WHEN, in the course of human events, it becomes necessary for one people to dissolve the political bands which have connected them with another, and to assume, among the powers of the earth, the separate and equal station to which the laws of nature and of nature's God entitle them, a decent respect to the opinions of mankind requires that they should declare the causes which impel

Lower case a to z, 13 $\frac{2}{3}$ ems

ABCDEFGHIJKLMNOPQRSTUVWXYZ
1234567890

14 POINT NO 64

WHEN, in the course of human events, it becomes necessary for one people to dissolve the political bands which have connected them with another, and to assume, among the powers of the earth, the separate and equal station to which the laws of nature and of nature's God entitle them, a decent respect to the opinions of mankind requires

Lower case a to z, 11 $\frac{2}{3}$ ems

ABCDEFGHIJKLMNOPQRSTUVWXYZ
1234567890

MODERN ROMAN SERIES No 65

5½ POINT NO 65

WHEN, in the course of human events, it becomes necessary for one people to dissolve the political bands which have connected them with another, and to assume, among the powers of the earth, the separate and equal station to which the laws of nature and of nature's God entitle them, a decent respect to the opinions of mankind requires that they should declare the causes which impel them to the separation. We hold these truths to be self-evident, that all men are created equal; that they are endowed by their Creator with certain unalienable rights; that among these, are life, liberty, and the pursuit of happiness. That, to secure these rights, governments are instituted among men, deriving their just powers from the consent of the governed; that, whenever any form of government becomes destructive of these ends, it is the right of the people to

Lower case a to z, 15¾ ems

ABCDEFGHIJKLMN OPQRSTUVWXYZ
1234567890

6 POINT NO 65

WHEN, in the course of human events, it becomes necessary for one people to dissolve the political bands which have connected them with another, and to assume, among the powers of the earth, the separate and equal station to which the laws of nature and of nature's God entitle them, a decent respect to the opinions of mankind requires that they should declare the causes which impel them to the separation. We hold these truths to be self-evident, that all men are created equal; that they are endowed by their Creator with certain unalienable rights; that among these, are life, liberty, and the pursuit of happiness. That, to secure these rights, governments are instituted among men, deriving their just powers from the consent of the gov-

Lower case a to z, 15 ems

ABCDEFGHIJKLMN OPQRSTUVWXYZ
1234567890

7 POINT NO 65

WHEN, in the course of human events, it becomes necessary for one people to dissolve the political bands which have connected them with another, and to assume, among the powers of the earth, the separate and equal station to which the laws of nature and of nature's God entitle them, a decent respect to the opinions of mankind requires that they should declare the causes which impel them to the separation. We hold these truths to be self-evident, that all men are created equal; that they are endowed by their Creator with certain unalienable rights; that among these, are life, liberty, and the pursuit of happiness. That, to secure these rights, governments are instituted among men, deriving their just powers from the consent of the governed; that, whenever any form of government becomes destructive of these ends, it is the right of the people to alter or to abolish it, and to institute a new government, laying its foundation on such principles, and organizing its powers in such form, as to them shall seem most likely to effect their safety and happiness. Prudence, indeed, will dictate that governments long established, should not be changed for light and transient causes; and, accordingly, all experience hath shown, that mankind are more

Lower case a to z, 13¾ ems

ABCDEFGHIJKLMN OPQRSTUVWXYZ
1234567890

8 POINT NO 65

WHEN, in the course of human events, it becomes necessary for one people to dissolve the political bands which have connected them with another, and to assume, among the powers of the earth, the separate and equal station to which the laws of nature and of nature's God entitle them, a decent respect to the opinions of mankind requires that they should declare the causes which impel them to the separation. We hold these truths to be self-evident, that all men are created equal; that they are endowed by their Creator with certain unalienable rights; that among these, are life, liberty, and the pursuit of happiness. That, to secure these rights, governments are instituted among men, deriving their just powers from the consent of the governed; that, whenever any form of government becomes destructive of these ends, it is the right of the people to alter or to abolish it, and to institute a new government, laying its foundation

Lower case a to z, 14 ems

ABCDEFGHIJKLMN OPQRSTUVWXYZ
1234567890

9 POINT NO 65

WHEN, in the course of human events, it becomes necessary for one people to dissolve the political bands which have connected them with another, and to assume, among the powers of the earth, the separate and equal station to which the laws of nature and of nature's God entitle them, a decent respect to the opinions of mankind requires that they should declare the causes which impel them to the separation. We hold these truths to be self-evident, that all men are created equal; that they are endowed by their Creator with certain unalienable rights; that among these, are life, liberty, and the pursuit of happiness. That, to secure these rights, governments are *instituted among men, deriving their just powers from the consent of the governed; that, whenever any form of government becomes de-*

Lower case a to z, 12¼ ems

ABCDEFGHIJKLMNOPQRSTUVWXYZ

1234567890

10 POINT NO 65

WHEN, in the course of human events, it becomes necessary for one people to dissolve the political bands which have connected them with another, and to assume, among the powers of the earth, the separate and equal station to which the laws of nature and of nature's God entitle them, a decent respect for the opinions of mankind requires that they should declare the causes which impel them to the separation. We hold these truths to be self-evident, that all men are created equal; that they are endowed by their Creator with certain unalienable rights; that *among these, are life, liberty, and the pursuit of happiness. That, to secure these rights, governments are instituted among*

Lower case a to z, 12¼ ems

ABCDEFGHIJKLMNOPQRSTUVWXYZ

1234567890

11 POINT NO 65

WHEN, in the course of human events, it becomes necessary for one people to dissolve the political bands which have connected them with another, and to assume, among the powers of the earth, the separate and equal station to which the laws of nature and of nature's God entitle them, a decent respect to the opinions of mankind requires that they should declare the causes which impel them to the separation. We hold these truths to be self-evident, that all men *are created equal; that they are endowed by their Creator with certain unalienable rights; that among these, are life,*

Lower case a to z, 12¼ ems

ABCDEFGHIJKLMNOPQRSTUVWXYZ

1234567890

MODERN ROMAN SERIES No 66

5½ POINT NO 66

WHEN, in the course of human events, it becomes necessary for one people to dissolve the political bands which have connected them with another, and to assume, among the powers of the earth, the separate and equal station to which the laws of nature and of nature's God entitle them, a decent respect to the opinions of mankind requires that they should declare the causes which impel them to the separation. We hold these truths to be self-evident, that all men are created equal; that they are endowed by their Creator with certain unalienable rights; that among these are life, liberty and the pursuit of happiness. That, to secure these rights, governments are instituted among men, deriving their just powers from the consent of the governed; that, whenever any form of government becomes destructive of these ends, it is the right of the people to alter or to abolish it, and to

Lower case a to z, 15 ems

ABCDEFGHIJKLMN OPQRSTUVWXYZ
1234567890

6 POINT NO 66

WHEN, in the course of human events, it becomes necessary for one people to dissolve the political bands which have connected them with another, and to assume, among the powers of the earth, the separate and equal station to which the laws of nature and of nature's God entitle them, a decent respect to the opinions of mankind requires that they should declare the causes which impel them to the separation. We hold these truths to be self-evident, that all men are created equal; that they are endowed by their Creator with certain unalienable rights; that among these, are life, liberty, and the pursuit of happiness. That to secure these rights, governments are instituted among men, deriving their just

Lower case a to z, 15 ems

ABCDEFGHIJKLMN OPQRSTUVWXYZ
1234567890

7 POINT NO 66

WHEN, in the course of human events, it becomes necessary for one people to dissolve the political bands which have connected them with another, and to assume, among the powers of the earth, the separate and equal station to which the laws of nature and of nature's God entitle them, a decent respect to the opinions of mankind requires that they should declare the causes which impel them to the separation. We hold these truths to be self-evident, that all men are created equal; that they are endowed by their Creator with certain unalienable rights; that among these, are life, liberty, and the pursuit of happiness. That, to secure these rights, governments are instituted among men, deriving their just powers from the consent of the governed; that, whenever any form of government becomes destructive of these ends, it is the right of the people to alter or to abolish it, and to institute a new government, laying its foundation on such principles, and organizing its powers in such form, as to them shall seem most likely to effect their safety and happiness. Prudence, indeed, will dictate that governments long established, should not be changed for light and transient causes

Lower case a to z, 14¼ ems

ABCDEFGHIJKLMN OPQRSTUVWXYZ
1234567890

8 POINT NO 66

WHEN, in the course of human events, it becomes necessary for one people to dissolve the political bands which have connected them with another, and to assume, among the powers of the earth, the separate and equal station to which the laws of nature and of nature's God entitle them, a decent respect to the opinions of mankind requires that they should declare the causes which impel them to the separation. We hold these truths to be self-evident, that all men are created equal; that they are endowed by their Creator with certain unalienable rights; that among these, are life, liberty, and the pursuit of happiness. That, to secure these rights, governments are instituted among men, deriving their just powers from the consent of the governed; that, whenever any government becomes destructive of these ends, it is the right of the people to alter or to abolish it, and to institute a new

Lower case a to z, 14 ems

ABCDEFGHIJKLMN OPQRSTUVWXYZ
1234567890

MODERN ROMAN SERIES No 67

5 POINT NO 67

WHEN, in the course of human events, it becomes necessary for one people to dissolve the political bands which have connected them with another, and to assume, among the powers of the earth, the separate and equal station to which the laws of nature and of nature's God entitle them, a decent respect to the opinions of mankind requires that they should declare the causes which impel them to the separation. We hold these truths to be self-evident, that all men are created equal; that they are endowed by their Creator with certain unalienable rights: that among these are life, liberty and the pursuit of happiness. That to secure these rights, governments are instituted among men, deriving their just powers from the consent of the governed; that whenever any form of government becomes destructive of these ends, it is the right of the people to alter or to abolish it, and to institute a new government, laying its foundation on such principles, and organizing its powers in such form as to them shall seem most likely to effect their safety and happiness. *Prudence, indeed, will dictate that governments long*

Lower case a to z, 14½ ems

ABCDEFGHIJKLMN OPQRSTUVWXYZ
1234567890

5½ POINT NO 67

WHEN, in the course of human events, it becomes necessary for one people to dissolve the political bands which have connected them with another, and to assume, among the powers of the earth, the separate and equal station to which the laws of nature and of nature's God entitle them, a decent respect to the opinions of mankind requires that they should declare the causes which impel them to the separation. We hold these truths to be self-evident, that all men are created equal; that they are endowed by their Creator with certain unalienable rights; that among these, are life, liberty, and the pursuit of happiness. That, to secure these rights, governments are instituted among men, deriving their just powers from the consent of the governed; that, whenever any form of government becomes destructive of these ends, it is the right of the people to alter

Lower case a to z, 15½ ems

ABCDEFGHIJKLMN OPQRSTUVWXYZ
1234567890

6 POINT NO 67

WHEN, in the course of human events, it becomes necessary for one people to dissolve the political bands which have connected them with another, and to assume, among the powers of the earth, the separate and equal station to which the laws of nature and of nature's God entitle them, a decent respect to the opinions of mankind requires that they should declare the causes which impel them to the separation. We hold these truths to be self-evident, that all men are created equal; that they are endowed by their Creator with certain unalienable rights; that among these, are life, liberty, and the pursuit of happiness. That, to secure these rights, governments are instituted among men, deriving their just powers from the consent of the governed; that, whenever any form of government becomes destructive of these ends, it is the right of the people to alter or to abolish it, and to institute a new government, laying its foundation on such principles, and organizing its powers in such form, as to them shall seem most likely to effect their safety and happiness. Prudence, indeed, will dictate that governments long established, should not be changed for light and transient causes; and, accordingly, all experience hath shown, that mankind are more disposed to suffer, while evils are sufferable, than to right themselves by abolishing the forms to which they are accustomed. *But, when a long train of abuses and usurpations, pursuing invariably the same object, evinces a design to reduce them under absolute despotism, it is their right,*

Lower case a to z, 15½ ems

ABCDEFGHIJKLMN OPQRSTUVWXYZ
1234567890

7 POINT NO 67

WHEN, in the course of human events, it becomes necessary for one people to dissolve the political bands which have connected them with another, and to assume, among the powers of the earth, the separate and equal station to which the laws of nature and of nature's God entitle them, a decent respect to the opinions of mankind requires that they should declare the causes which impel them to the separation. We hold these truths to be self-evident, that all men are created equal; that they are endowed by their Creator with certain unalienable rights; that among these, are life, liberty, and the pursuit of happiness. That, to secure these rights, governments are instituted among men, deriving their just powers from the consent of the governed; that, whenever any form of government becomes destructive of these ends, it is the right of the people to alter or to abolish it, and to institute a new government, laying its foundation on such principles, and organizing its powers in such form, as to them shall seem most likely to effect their safety and happiness. *Prudence, indeed, will dictate that governments long established, should not be changed for light and*

Lower case a to z, 14¾ ems

ABCDEFGHIJKLMN OPQRSTUVWXYZ
1234567890

8 POINT NO 67

WHEN, in the course of human events, it becomes necessary for one people to dissolve the political bands which have connected them with another, and to assume, among the powers of the earth, the separate and equal station to which the laws of nature and of nature's God entitle them, a decent respect to the opinions of mankind requires that they should declare the causes which impel them to the separation. We hold these truths to be self-evident, that all men are created equal; that they are endowed by their Creator with certain unalienable rights; that among these, are life, liberty, and the pursuit of happiness. That, to secure these rights, governments are instituted among men, deriving their just powers from the consent of the governed; that, whenever any form of government becomes destructive of these ends, it is the right of *the people to alter or to abolish it, and to institute a new government, laying its foundation on such principles, and organizing its powers in such form,*

Lower case a to z, 14 ems

ABCDEFGHIJKLMNOPQRSTUVWXYZ

1234567890

9 POINT NO 67

WHEN, in the course of human events, it becomes necessary for one people to dissolve the political bands which have connected them with another, and to assume, among the powers of the earth, the separate and equal station to which the laws of nature and of nature's God entitle them, a decent respect to the opinions of mankind requires that they should declare the causes which impel them to the separation. We hold these truths to be self-evident, that all men are created equal; that they are endowed by their Creator with certain unalienable rights; that among these, are life, liberty, and the pursuit of happiness. That, to secure these rights, governments are instituted among men, deriving *their just powers from the consent of the governed; that, whenever any form of government becomes destructive of these ends, it is the right of the people*

Lower case a to z, 12½ ems

ABCDEFGHIJKLMNOPQRSTUVWXYZ

1234567890

10 POINT NO 67

WHEN, in the course of human events, it becomes necessary for one people to dissolve the political bands which have connected them with another, and to assume, among the powers of the earth, the separate and equal station to which the laws of nature and of nature's God entitle them, a decent respect to the opinions of mankind requires that they should declare the causes which impel them to the separation. We hold these truths to be self-evident, that all men are created equal; that they are endowed with certain unalienable rights; that among these, are *life, liberty, and the pursuit of happiness. That, to secure these rights, governments are instituted among men, deriving their*

Lower case a to z, 12½ ems

ABCDEFGHIJKLMNOPQRSTUVWXYZ

1234567890

11 POINT No 67

WHEN, in the course of human events, it becomes necessary for one people to dissolve the political bands which have connected them with another, and to assume, among the powers of the earth, the separate and equal station to which the laws of nature and of nature's God entitle them, a decent respect to the opinions of mankind requires that they should declare the causes which impel them to the separation. We hold these truths to be self-evident, that all men *are created equal; that they are endowed by their Creator with certain unalienable rights; that among these, are life,*

Lower case a to z, 12 ems

ABCDEFGHIJKLMNOPQRSTUVWXYZ
1234567890

12 POINT No 67

WHEN, in the course of human events, it becomes necessary for one people to dissolve the political bands which have connected them with another, and to assume, among the powers of the earth, the separate and equal station to which the laws of nature and of nature's God entitle them, a decent respect to the opinions of mankind requires that they should *declare the causes which impel them to the separation. We hold these truths to be self-evident, that all men*

Lower case a to z, 12½ ems

ABCDEFGHIJKLMNOPQRSTUVWXYZ
1234567890

18 POINT No 67

WHEN, in the course of human events, it becomes necessary for one people to dissolve the political bands which *have connected them with another, and to assume, among the powers of the*

ABCDEFGHIJKLMNOPQRSTUVWXYZ
1234567890

MODERN ROMAN SERIES No 68

— E —

6 POINT No 68

WHEN, in the course of human events, it becomes necessary for one people to dissolve the political bands which have connected them with another, and to assume, among the powers of the earth, the separate and equal station to which the laws of nature and of nature's God entitle them, a decent respect to the opinions of mankind requires that they should declare the causes which impel them to the separation. We hold these truths to be self-evident, that all men are created equal; that they are endowed by their Creator with certain unalienable rights; that among these, are life, liberty, and the pursuit of happiness. That, to secure these rights, governments are instituted among men, deriving their just powers from the consent of the governed; that, whenever any form of government becomes destructive of these ends, it is the right of the people to alter or to abolish it, and to institute a new government, laying its foundation on such principles, and organizing its powers in such form, as to them shall seem most likely to effect their safety and happiness. Prudence, indeed, will dictate that governments long established, should not be changed for light and transient causes; and, accordingly, all *experience hath shown, that mankind are more disposed to suffer, while evils are sufferable, than to right themselves by abolishing the forms to which they are accus-*

Lower case a to z, 17 ems

ABCDEFGHIJKLMNOPQRSTUVWXYZ
1234567890

7 POINT No 68

WHEN, in the course of human events, it becomes necessary for one people to dissolve the political bands which have connected them with another, and to assume, among the powers of the earth, the separate and equal station to which the laws of nature and of nature's God entitle them, a decent respect to the opinions of mankind requires that they should declare the causes which impel them to the separation. We hold these truths to be self-evident, that all men are created equal; that they are endowed by their Creator with certain unalienable rights; that among these, are life, liberty, and the pursuit of happiness. That, to secure these rights, governments are instituted among men, deriving their just powers from the consent of the governed; that, whenever any form of government becomes destructive of these ends, it is the right of the people to alter or to abolish it, and to institute a new government, laying its foundation on such principles, and organizing its powers in such form, as to them shall seem most likely to effect their safety and happiness. Prudence, indeed,

Lower case a to z, 15½ ems

ABCDEFGHIJKLMNOPQRSTUVWXYZ
1234567890

8 POINT No 68

WHEN, in the course of human events, it becomes necessary for one people to dissolve the political bands which have connected them with another, and to assume, among the powers of the earth, the separate and equal station to which the laws of nature and of nature's God entitle them, a decent respect to the opinions of mankind requires that they should declare the causes which impel them to the separation. We hold these truths to be self-evident, that all men are created equal; that they are endowed by their Creator with certain unalienable rights; that among these, are life, liberty, and the pursuit of happiness. That, to secure these rights, governments are instituted among men, deriving their just powers from the consent of the governed; that, whenever any form of government becomes destructive of these ends, it is the right of the people to alter or abolish

Lower case a to z, 14½ ems

ABCDEFGHIJKLMNOPQRSTUVWXYZ
1234567890

CENTURY ROMAN

8 POINT

THE first number of *The Century* appeared in a modernized old-style type, which was then something of a novelty. It had never been used in any similar publication, and it gave distinction to the page. It had authority in its favor, as the outgrowth of a style (shown on pages 104 and 105 of this book), brought out by WILLIAM CASLON of London about 1720, and then so pleasingly cut that it broke down every attempt at rivalry. For seventy years it was commended as incomparably the best cut of type, but it went out of fashion. At the beginning of the present century readers complained of its angularity and grayness.

THEY demanded new styles, and the type-founders provided them in profusion: the Thorne fat-face of prodigious blackness; the Didot round-face, not quite as black or fat-faced; the Bodoni, with round letters and sharp hair-lines; the French poetic face, compressed to the extreme of tenuity; the so-called Scotch-face (devised by the late S. N. DICKINSON of Boston, who established the Dickinson Type Foundry, the Boston Branch of the American Type Founders' Company, although first cut in Edinburgh); and the skeleton light-face, with its razor-edged hair-lines and needle-like pointed stems, *fashionable during the first part of century*

Lower case a to z, 12 ems

ABCDEFGHIJKLMN OPQRSTUVWXYZ — \$1234567890

9 POINT

WHEN PICKERING and WHITTINGHAM revived the CASLON Old Style, in 1850, using the identical matrices of the old master, the connoisseurs said, "Now at last we have returned to simplicity and beauty; this is perfection!" Yet it was admired by bibliophiles only; dainty readers did not approve of its angular letters and its disproportioned capitals. Accepted for reprints of old books, it was rejected for modern work. To make it palatable to the general reader, type-founders devised a "modernized old-style," in which harsh features were modified and new features of great delicacy were added. So changed, it became a more salable letter, but it never found marked favor with the ordinary newspaper or the book publisher. Critics said of it (too severely, we think) that the strong features of the Caslon face had been suppressed, and that the new features were no improvement; that it had *been made lighter, sharper, and broader, until its true character had been cut to pieces.*

Lower case a to z, 12¼ ems

ABCDEFGHIJKLMN OPQRSTUVWXYZ — \$1234567890

10 POINT

BIBLIOPHILES still prefer the cut of CASLON; with all its admitted faults, it is blacker, clearer, and more readable. The average reader rejects the angularities of the old and the new cut, and prefers the symmetry of types of modern fashion. In the bewildering variety of faces devised during this century, one peculiarity, the sharp hair-line (a fashion introduced by BODONI and DIDOT, in imitation of the delicate lines of the copper-plate printer), has never been changed. When printing was done upon wet paper, against an elastic blanket, the hair-line was necessarily thickened by its impress against the yielding paper, which overlapped the sides of every line. Under this treatment the hair-line appeared thicker in print than in type, and was unobjectionable to printer or reader; but when the new method began (as it *did in 1872) of printing on dry and smooth paper against an inelastic surface*

Lower case a to z, 12 ems

ABCDEFGHIJKLMN OPQRSTUVWXYZ — \$1234567890

CENTURY ROMAN No 2

10 POINT

HISTORY OF THE RESCUE OF THE DUCHESS DE DRAGONFLIES.—EXTRACTED FROM UNPUBLISHED MEMOIRS OF THE NOBLE SIR JOHN BEETLEBACK.

OF the high doings chronicled in this reign few there be that smack more of herohood than the rescuing of the Duchess de Dragonflies, in ever-memory of which does our present sovereign, once Prince Junebug, bear upon his arms, gules, three dragonflies displayed. While I enjoyed the confidence of their serene majesties, honor forbade that I should set forth at large the true inwards of this so-called “rescue,” forsooth; but now that I be in exile, denied even the poor privilege of mingling my dust with that of my kin, naught hinders me from recounting this doughty deed of arms nor of depicting with what skill the re-capture of the Duchess was effected, and to whom her restoration was in truth owing.

Be it known, then, that the Baron Spiderlegs had long sorely coveted the broad estates of the Dragonflies; but dared not to make move to obtain them so long as the Duke held sway. But when his Grace had set forth for the Holy Land—whence all know he never returned—the Baron laid a crafty snare wherein he hoped to take the young Duchess. In this wise did he devise: Knowing full well that the Duchess yearned for fair flowers, and counted no hardship too grievous that gained a new blossom for her houses of crystal, he did craftily contrive to besprinkle her Grace’s daily walk with strange and curious flowers, the which were set in place by an Asiatic gardener, sent by night from the Baron’s castle for the doing of this very thing. Now these same blossoms did seem to grow more beautiful and rare day by day, and in degree that they were further afield from the palace of the Duchess and nearer to the Baron’s castle. And yet, such was the guile of Baron Spiderlegs, the Duchess could never by any chance come upon these same dainties of the woods save when alone or accompanied only by her maids or tiring women. A marvel, indeed, would this have been, were it not for the agency of the said Asiatic varlet, who, lurking craftily in hidden nooks, would take up all he had so laboriously planted, if so much as a single man-at-arms were in the train of the Duchess. So it came about that one day, as the Duchess de Dragonflies bent to pluck a blind gentian, a great cloth-web of silken stuff was dropped upon her; she was lifted to the back of a black charger and whisked away to the Baron’s castle.

Lower case a to z, 12 ems

ABCDEFGHIJKLMNOPQRSTUVWXYZ

· 1234567890

SERIES NO 46—NEWSPAPER STYLE

5½ POINT NO 46

WHEN, in the course of human events, it becomes necessary for one people to dissolve the political bands which have connected them with another, and to assume, among the powers of the earth, the separate and equal station to which the laws of nature and of nature's God entitle them, a decent respect to the opinions of mankind requires that they should declare the causes which impel them to the separation. We hold these truths to be self-evident, that all men are created equal; that they are endowed by their Creator with certain unalienable rights; that among these, are life, liberty, and the pursuit of happiness. That, to secure these rights, governments are instituted among men, deriving their just powers from the consent of the governed; that, whenever any form of government becomes destructive of these ends, it is the right of the people to alter or to abolish it, and to institute a new government, laying its foundation on such principles, and organizing its powers in such form, as to them shall seem most likely to effect their safety and happiness. Prudence, indeed, will dictate that governments long established, should not be changed for light and transient causes; and, accordingly, all experience hath shown, that mankind are more disposed to suffer, while evils are sufferable, than to right themselves by abolishing the forms to which they are accustomed. But, when a long train of abuses and usurpations, pursuing invariably the same object, evinces a design to reduce them under absolute despotism, it is their right, it is

Lower case a to z, 16 ems

6 POINT NO 46

WHEN, in the course of human events, it becomes necessary for one people to dissolve the political bands which have connected them with another, and to assume, among the powers of the earth, the separate and equal station to which the laws of nature and of nature's God entitle them, a decent respect to the opinions of mankind requires that they should declare the causes which impel them to the separation. We hold these truths to be self-evident, that all men are created equal; that they are endowed by their Creator with certain unalienable rights; that among these, are life, liberty, and the pursuit of happiness. That, to secure these rights, governments are instituted among men, deriving their just powers from the consent of the governed; that, whenever any form of government becomes destructive of these ends, it is the right of the people to alter or to abolish it, and to institute a new government, laying its foundation on such principles, and organizing its powers in such form, as to them shall seem most likely to effect their safety and happiness. Prudence, indeed, will dictate that governments long established should not be changed for light and transient causes; and, accordingly, all experience hath shown, that mankind are more disposed to suffer, while evils are sufferable, than

Lower case a to z, 16¾ ems

For other sizes of this series, see pages 34 and 35

7 POINT NO 46

WHEN, in the course of human events, it becomes necessary for one people to dissolve the political bands which have connected them with another, and to assume, among the powers of the earth, the separate and equal station to which the laws of nature and of nature's God entitle them, a descent respect to the opinions of mankind requires that they should declare the causes which impel them to the separation. We hold these truths to be self-evident, that all men are created equal; that they are endowed by their Creator with certain unalienable rights; that among these, are life, liberty, and the pursuit of happiness. That, to secure these rights, governments are instituted among men, deriving their just powers from the consent of the governed; that, whenever any form of government becomes destructive of these ends, it is the right of the people to alter or to abolish it, and to institute a new government, laying its foundation on such principles, and organizing its powers in such form, as to them shall seem most likely to effect their safety and happiness. Prudence, indeed, will

Lower case a to z, 16 ems

8 POINT NO 46

WHEN, in the course of human events, it becomes necessary for one people to dissolve the political bands which have connected them with another, and to assume, among the powers of the earth, the separate and equal station to which the laws of nature and of nature's God entitle them, a decent respect for the opinions of mankind requires that they should declare the causes which impel them to the separation. We hold these truths to be self-evident, that all men are created equal; that they are endowed by their Creator with certain unalienable rights; that among these, are life, liberty, and the pursuit of happiness. That, to secure these rights, governments are instituted among men, deriving their just powers from the consent of the governed; that, whenever any form of government becomes destructive of these ends, it is the right of the people to alter or to abolish it, and to institute a

Lower case a to z, 15¼ ems

SERIES No 47—NEWSPAPER STYLE

5½ POINT NO 47

WHEN, in the course of human events, it becomes necessary for one people to dissolve the political bands which have connected them with another, and to assume, among the powers of the earth, the separate and equal station to which the laws of nature and of nature's God entitle them, a decent respect to the opinions of mankind requires that they should declare the causes which impel them to the separation. We hold these truths to be self-evident, that all men are created equal; that they are endowed by their Creator with certain unalienable rights; that among these, are life, liberty, and the pursuit of happiness. That, to secure these rights, governments are instituted among men, deriving their just powers from the consent of the governed; that, whenever any form of government becomes destructive of these ends, it is the right of the people to alter or to abolish it, and to institute a new government, laying its foundation on such principles, and organizing its powers in such form, as to them shall seem most likely to effect their safety and happiness. Prudence, indeed, will dictate that governments long established, should not be changed for light and transient causes; and, accordingly, all experience hath shown, that mankind are more disposed to suffer, while evils are sufferable, than to right themselves by abolishing the forms to which they are accustomed. But when a long train of abuses and usurpations, pursuing invariably the same object, evinces a design to reduce them under absolute despotism, it is their right, it is their duty, to throw off such government, and to provide new guards for

Lower case a to z, 15 ems

6 POINT NO 47

WHEN, in the course of human events, it becomes necessary for one people to dissolve the political bands which have connected them with another, and to assume, among the powers of the earth, the separate and equal station to which the laws of nature and of nature's God entitle them, a decent respect to the opinions of mankind requires that they should declare the causes which impel them to the separation. We hold these truths to be self-evident, that all men are created equal; that they are endowed by their Creator with certain unalienable rights; that among these, are life, liberty, and the pursuit of happiness. That, to secure these rights, governments are instituted among men, deriving their just powers from the consent of the governed; that, whenever any form of government becomes destructive of these ends, it is the right of the people to alter or to abolish it, and to institute a new government, laying its foundation on such principles, and organizing its powers in such form, as to them shall seem most likely to effect their safety and happiness. Prudence, indeed, will dictate that governments long established, should not be changed for light and transient causes; and, accordingly, all experience hath shown, that mankind are more disposed to suffer, while evils are sufferable, than to right themselves by abolishing

Lower case a to z, 15½ ems

For other sizes of this series, see pages 37 and 38

7 POINT NO 47

WHEN, in the course of human events, it becomes necessary for one people to dissolve the political bands which have connected them with another, and to assume, among the powers of the earth, the separate and equal station to which the laws of nature and of nature's God entitle them, a decent respect to the opinions of mankind requires that they should declare the causes which impel them to the separation. We hold these truths to be self-evident, that all men are created equal; that they are endowed by their Creator with certain unalienable rights; that among these, are life, liberty, and the pursuit of happiness. That, to secure these rights, governments are instituted among men, deriving their just powers from the consent of the governed; that, whenever any form of government becomes destructive of these ends, it is the right of the people to alter or to abolish it, and to institute a new government, laying its foundation on such principles, and organizing its powers in such form, as to them shall seem most likely to effect their safety and happiness. Prudence, indeed, will dictate that governments long established, should not be changed for light and transient causes; and, accordingly,

Lower case a to z, 14½ ems

8 POINT NO 47

WHEN, in the course of human events, it becomes necessary for one people to dissolve the political bands which have connected them with another, and to assume, among the powers of the earth, the separate and equal station to which the laws of nature and of nature's God entitle them, a decent respect to the opinions of mankind requires that they should declare the causes which impel them to the separation. We hold these truths to be self-evident, that all men are created equal; that they are endowed by their Creator with certain unalienable rights; that among these, are life, liberty, and the pursuit of happiness. That, to secure these rights, governments are instituted among men, deriving their just powers from the consent of the governed; that, whenever any form of government becomes destructive of these ends, it is the right of the people to alter or to abolish it, and to institute a new government, laying its foundation on such principles, and organizing its powers in such form, as to

Lower case a to z, 13½ ems

SERIES No 50—NEWSPAPER STYLE

6 POINT NO 50

WHEN, in the course of human events, it becomes necessary for one people to dissolve the political bands which have connected them with another, and to assume, among the powers of the earth, the separate and equal station to which the laws of nature and of nature's God entitle them, a decent respect to the opinion of mankind requires that they should declare the causes which impel them to the separation. We hold these truths to be self-evident, that all men are created equal; that they are endowed by their Creator with certain unalienable rights; that among these, are life, liberty, and the pursuit of happiness. That, to secure these rights, governments are instituted among men, deriving their just powers from the consent of the governed; that, whenever any form of government becomes destructive of these ends, it is the right of the people to alter or to abolish it, and to institute a new government, laying its foundation on such principles, and organizing its powers in such form, as to them shall seem most likely to effect their safety and happiness. Prudence, indeed, will dictate that governments long established, should not be changed for light and transient causes; and, *accordingly, all experience hath shown, that mankind are more disposed to suffer, while evils are sufferable, than to right themselves by abol-*

Lower case a to z, 15¾ ems

7 POINT NO 50

WHEN, in the course of human events, it becomes necessary for one people to dissolve the political bands which have connected them with another, and to assume, among the powers of the earth, the separate and equal station to which the laws of nature and of nature's God entitle them, a decent respect to the opinions of mankind requires that they should declare the causes which impel them to the separation. We hold these truths to be self-evident, that all men are created equal; that they are endowed by their Creator with certain unalienable rights; that among these, are life, liberty, and pursuit of happiness. That, to secure these rights, governments are instituted among men, deriving their just powers from the consent of the governed; that, whenever any form of government becomes destructive of these ends, it is the right of the people to alter or to abolish it, and to institute a new government, laying its foundation on such principles, and organizing its powers in such form, as to them shall seem most

Lower case a to z, 14¾ ems

This series also shown on pages 40 and 41

8 POINT NO 50

WHEN, in the course of human events, it becomes necessary for one people to dissolve the political bands which have connected them with another, and to assume, among the powers of the earth, the separate and equal station to which the laws of nature and of nature's God entitle them, a decent respect to the opinions of mankind requires that they should declare the causes which impel them to the separation. We hold these truths to be self-evident, that all men are created equal; that they are endowed by their Creator with certain unalienable rights; that among these are life, liberty, and the pursuit of happiness. That, to secure these rights, governments are instituted among men, deriving their just powers from the consent of the governed; that, whenever any form of government becomes destructive of these ends, it is the right of the people to alter or to abolish it, and to institute a new government, laying its foundation on

Lower case a to z, 14 ems

9 POINT NO 50

WHEN, in the course of human events, it becomes necessary for one people to dissolve the political bands which have connected them with another, and to assume, among the powers of the earth, the separate and equal station to which the laws of nature and of nature's God entitle them, a decent respect to the opinions of mankind requires that they should declare the causes which impel them to the separation. We hold these truths to be self-evident, that all men are created equal; that they are endowed by their Creator with certain unalienable rights;—among these, are life, liberty, and pursuit of happiness. That, to secure these rights, governments are instituted among men, deriving their just powers from the consent of the governed; that, whenever any form of government be-

Lower case a to z, 14 ems

SERIES NO 53—NEWSPAPER STYLE

5½ POINT NO 53

WHEN, in the course of human events, it becomes necessary for one people to dissolve the political bands which have connected them with another, and to assume, among the powers of the earth, the separate and equal station to which the laws of nature and of nature's God entitle them, a decent respect to the opinions of mankind requires that they should declare the causes which impel them to the separation. We hold these truths to be self-evident, that all men are created equal; that they are endowed by their Creator with certain unalienable rights; that among these, are life, liberty, and the pursuit of happiness. That, to secure these rights, governments are instituted among men, deriving their just powers from the consent of the governed; that, whenever any government becomes destructive of these ends, it is the right of the people to alter or to abolish it, and to institute a new government, laying its foundation on such principles, and organizing its powers in such form, as to them shall seem most likely to effect their safety and happiness. Prudence, indeed, will dictate that governments long established, should not be changed for light and transient causes; and accordingly, all experience hath shown, that mankind are more disposed to suffer, while evils are sufferable, than to right themselves by abolishing the forms to which they are accustomed. But, when a long train of abuses and usurpations, pursuing invariably the same object, evinces a design to reduce them under absolute despotism, it is their right, it is their duty,

Lower case a to z, 16¼ ems

6 POINT NO 53

WHEN, in the course of human events, it becomes necessary for one people to dissolve the political bands which have connected them with another, and to assume, among the powers of the earth, the separate and equal station to which the laws of nature and of nature's God entitle them, a decent respect for the opinions of mankind requires that they should declare the causes which impel them to the separation. We hold these truths to be self-evident, that all men are created equal; that they are endowed by their Creator with certain unalienable rights; that among these, are life, liberty, and the pursuit of happiness. That, to secure these rights, governments are instituted among men, deriving their just powers from the consent of the governed; that whenever any form of government becomes destructive of these ends, it is the right of the people to alter or to abolish it, and to institute a new government, laying its foundation on such principles, and organizing its powers in such form, as to them shall seem most likely to effect their safety and happiness. Prudence, indeed, will dictate that governments long established, should not be changed for light and transient causes; and, accordingly, all experience hath shown, that mankind are more disposed to suffer, while evils are sufferable, than to right themselves

Lower case a to z, 15⅞ ems

This series also shown on page 59

7 POINT NO 53

WHEN, in the course of human events, it becomes necessary for one people to dissolve the political bands which have connected them with another, and to assume, among the powers of the earth, the separate and equal station to which the laws of nature and of nature's God entitle them, a decent respect to the opinions of mankind requires that they should declare the causes which impel them to the separation. We hold these truths to be self-evident, that all men are created equal; that they are endowed by their creator with certain unalienable rights, that among these, are life, liberty, and the pursuit of happiness. That, to secure these rights, governments are instituted among men, deriving their just powers from the consent of the governed; that, whenever any government becomes destructive of these ends, it is the right of the people to alter or to abolish it, and to institute a new government, laying its foundation on such principles, and organizing its powers in such form, as to them shall seem most likely to effect their safety and happiness. Prudence, indeed, will dictate that governments long established, should not be

Lower case a to z, 15½ ems

8 POINT NO 53

WHEN, in the course of human events, it becomes necessary for one people to dissolve the political bands which have connected them with another, and to assume among the powers of the earth, the separate and equal station to which the laws of nature and of nature's God entitle them, a decent respect to the opinions of mankind requires that they should declare the causes which impel them to the separation. We hold these truths to be self-evident, that all men are created equal; that they are endowed by their Creator with certain unalienable rights; that among these, are life, liberty, and the pursuit of happiness. That, to secure these rights, governments are instituted among men, deriving their just powers from the consent of the governed; that, whenever any form of government becomes destructive of these ends, it is the right of the people to alter or to abolish it, and to institute a new government, laying

Lower case a to z, 14⅔ ems

LARGE-FACE SERIES NO 54—NEWSPAPER STYLE

6 POINT NO 54

WHEN, in the course of human events, it becomes necessary for one people to dissolve the political bands which have connected them with another, and to assume, among the powers of the earth, the separate and equal station to which the laws of nature and of nature's God entitle them, a decent respect to the opinions of mankind requires that they should declare the causes which impel them to the separation. We hold these truths to be self-evident, that all men are created equal; that they are endowed by their Creator with certain unalienable rights; that among these, are life, liberty, and the pursuit of happiness. That, to secure these rights, governments are instituted among men, deriving their just powers from the consent of the governed; that, whenever any form of government becomes destructive of these ends, it is the right of the people to alter or to abolish it, and to institute a new government, laying its foundation on such principles, and organizing its powers in such form, as to them shall seem most likely to effect their safety and happiness. Prudence, indeed, will dictate that governments long established, should not be changed for light and transient causes; and, accordingly, all experience hath shown, that mankind are more disposed to suffer, while evils are sufferable, than to right themselves by abolishing the forms to which they are accustomed. But, when a long train of

Lower case a to z, 15 $\frac{3}{4}$ ems

7 POINT NO 54

WHEN, in the course of human events, it becomes necessary for one people to dissolve the political bands which have connected them with another, and to assume, among the powers of the earth, the separate and equal station to which the laws of nature and of nature's God entitle them, a decent respect to the opinions of mankind requires that they should declare the causes which impel them to the separation. We hold these truths to be self-evident, that all men are created equal; that they are endowed by their Creator with certain unalienable rights; that among these, are life, liberty, and the pursuit of happiness. That, to secure these rights, governments are instituted among men, deriving their just powers from the consent of the governed; that, whenever any form of government becomes destructive of these ends, it is the right of the people to alter or to abolish it, and to institute a new government, laying its foundation on such principles, and organizing its powers in such form, as to them shall seem most likely to effect their safety and happi-

Lower case a to z, 15 ems

For other sizes of this series, see pages 42 and 43

8 POINT NO 54

WHEN, in the course of human events, it becomes necessary for one people to dissolve the political bands which have connected them with another, and to assume, among the powers of the earth, the separate and equal station to which the laws of nature and of nature's God entitle them, a decent respect to the opinions of mankind requires that they should declare the causes which impel them to the separation. We hold these truths to be self-evident, that all men are created equal; that they are endowed by their Creator with certain unalienable rights; that among these, are life, liberty, and the pursuit of happiness. That, to secure these rights, governments are instituted among men, deriving their just powers from the consent of the governed; that, whenever any form of government becomes destructive of these ends, it is the right of the people to alter or to abolish it, and to institute a new government, laying its foundation on such principles, and organizing its

Lower case a to z, 14 $\frac{1}{4}$ ems

9 POINT NO 54

WHEN, in the course of human events, it becomes necessary for one people to dissolve the political bands which have connected them with another, and to assume, among the powers of the earth, the separate and equal station to which the laws of nature and of nature's God entitle them, a decent respect to the opinions of mankind requires that they should declare the causes which impel them to the separation. We hold these truths to be self-evident, that all men are created equal; that they are endowed by their Creator with certain unalienable rights; that among these, are life, liberty, and the pursuit of happiness. That, to secure these rights, governments are instituted among men, deriving their just powers from the consent of the governed; that, whenever any form of government becomes destructive of these ends, it is the right of the people to alter or to abolish

Lower case a to z, 13 ems

INLAND SERIES No 56—NEWSPAPER STYLE

5½ POINT NO 56

WHEN, in the course of human events, it becomes necessary for one people to dissolve the political bands which have connected them with another, and to assume, among the powers of the earth, the separate and equal station, to which the laws of nature and of nature's God entitle them, a decent respect to the opinions of mankind requires that they should declare the causes which impel them to the separation. We hold these truths to be self-evident, that all men are created equal; that they are endowed by their Creator with certain unalienable rights; that among these, are life, liberty, and the pursuit of happiness. That, to secure these rights, governments are instituted among men, deriving their just powers from the consent of the governed; that, whenever any form of government becomes destructive of these ends, it is the right of the people to alter or to abolish it, and to institute a new government, laying its foundation on such principles, and organizing its powers in such form, as to them shall seem most likely to effect their safety and happiness. Prudence, indeed, will dictate that governments long established, should not be changed for light and transient causes; and, accordingly, all experience hath shown, that mankind are more disposed to suffer, while evils are sufferable, than to right themselves by abolishing the forms to which they are accustomed. But, when a long train of abuses and usurpations, pursuing in-

Lower case a to z, 17½ ems

6 POINT NO 56

WHEN, in the course of human events, it becomes necessary for one people to dissolve the political bands which have connected them with another, and to assume, among the powers of the earth, the separate and equal station to which the laws of nature and of nature's God entitle them, a decent respect to the opinions of mankind requires that they should declare the causes which impel them to the separation. We hold these truths to be self-evident, that all men are created equal; that they are endowed by their Creator with certain unalienable rights; that among these, are life, liberty, and the pursuit of happiness. That, to secure these rights, governments are instituted among men, deriving their just powers from the consent of the governed; that, whenever any form of government becomes destructive of these ends, it is the right of the people to alter or to abolish it, and to institute a new government, laying its foundation on such principles, and organizing its powers in such form, as to them shall seem most likely to effect their safety and happiness. Prudence, indeed, will dictate that governments long established, should not be changed for light and transient causes; and, accordingly, all experience

Lower case a to z, 18 ems

For other sizes of this series, see pages 44 and 45

7 POINT NO 56

WHEN, in the course of human events, it becomes necessary for one people to dissolve the political bands which have connected them with another, and to assume, among the powers of the earth, the separate and equal station to which the laws of nature and of nature's God entitle them, a decent respect to the opinions of mankind requires that they should declare the causes which impel them to the separation. We hold these truths to be self-evident, that all men are created equal; that they are endowed by their Creator with certain unalienable rights; that among these, are life, liberty, and the pursuit of happiness. That, to secure these rights, governments are instituted among men, deriving their power from the consent of the governed; that, whenever any form of government becomes destructive of these ends, it is the right of the people to alter or to abolish it, and to institute a new government, laying its foundation on such principles, and organizing its powers in such form, as to them shall seem most likely to effect their safety and happiness.

Lower case a to z, 17 ems

8 POINT NO 56

WHEN, in the course of human events, it becomes necessary for one people to dissolve the political bands which have connected them with another, and to assume, among the powers of the earth, the separate and equal station to which the laws of nature and of nature's God entitle them, a decent respect to the opinions of mankind requires that they should declare the causes which impel them to the separation. We hold these truths to be self-evident, that all men are created equal; that they are endowed by their Creator with certain unalienable rights; that among these, are life, liberty, and the pursuit of happiness. That, to secure these rights, governments are instituted among men, deriving their just powers from the consent of the governed; that, whenever any form of government becomes destructive of these ends, it is the right of the people to alter or to

Lower case a to z, 15¾ ems

SERIES NO 57—NEWSPAPER STYLE

6 POINT NO 57

WHEN, in the course of human events, it becomes necessary for one people to dissolve the political bands which have connected them with another, and to assume, among the powers of the earth, the separate and equal station to which the laws of nature and of nature's God entitle them, a decent respect to the opinions of mankind requires that they should declare the causes which impel them to the separation. We hold these truths to be self-evident, that all men are created equal; that they are endowed by their Creator with certain unalienable rights; that among these, are life, liberty, and the pursuit of happiness. That, to secure these rights, governments are instituted among men, deriving their just powers from the consent of the governed; that, whenever any government becomes destructive of these ends, it is the right of the people to alter or to abolish it, and to institute a new government, laying its foundation on such principles, and organizing its powers in such form, as to them shall seem most likely to effect their safety and happiness. Prudence, indeed, will dictate that governments long established, should not be changed for light and transient causes; *and, accordingly, all experience hath shown, that mankind are more disposed to suffer, while evils are sufferable, than to right themselves by*

Lower case a to z, 15¾ ems

7 POINT NO 57

WHEN, in the course of human events, it becomes necessary for one people to dissolve the political bands which have connected them with another, and to assume, among the powers of the earth, the separate and equal station to which the laws of nature and of nature's God entitle them, a decent respect to the opinions of mankind requires that they should declare the causes which impel them to the separation. We hold these truths to be self-evident, that all men are created equal; that they are endowed by their Creator with certain unalienable rights; that among these, are life, liberty, and the pursuit of happiness. That, to secure these rights, governments are instituted among men, deriving their just powers from the consent of the governed; that, whenever any form of government becomes destructive of these ends, it is the right of the people to alter or to abolish it, and to institute a new government, laying its foundation on such principles, and organizing its powers in such form, as to them shall seem

Lower case a to z, 14¾ ems

For other sizes of this series, see pages 46 and 47

8 POINT NO 57

WHEN, in the course of human events, it becomes necessary for one people to dissolve the political bands which have connected them with another, and to assume, among the powers of the earth, the separate and equal station to which the laws of nature and of nature's God entitle them, a decent respect for the opinions of mankind requires that they should declare the causes which impel them to the separation. We hold these truths to be self-evident, that all men are created equal; that they are endowed by their Creator with certain unalienable rights; that among these are life, liberty, and the pursuit of happiness. That, to secure these rights, governments are instituted among men, deriving their just powers from the consent of the governed; that, whenever any form of government becomes destructive of these ends, *it is the right of the people to alter or to abolish it, and to institute a new government, laying its founda-*

Lower case a to z, 14 ems

9 POINT NO 57

WHEN, in the course of human events, it becomes necessary for one people to dissolve the political bands which have connected them with another, and to assume, among the powers of the earth, the separate and equal station to which the laws of nature and of nature's God entitle them, a decent respect to the opinions of mankind requires that they should declare the causes which impel them to the separation. We hold these truths to be self-evident, that all men are created equal; that they are endowed by their Creator with certain unalienable rights; that among these, are life, liberty, and the pursuit of happiness. That, to secure these rights, governments are instituted among men, deriving their just powers from the consent of the governed; that, whenever any form of government becomes destructive and

Lower case a to z, 13¾ ems

WILSON SERIES No 60—NEWSPAPER STYLE

6 POINT No 60

WHEN, in the course of human events, it becomes necessary for one people to dissolve the political bands which have connected them with another, and to assume, among the powers of the earth, the separate and equal station to which the laws of nature and of nature's God entitle them, a decent respect to the opinions of mankind requires that they should declare the causes which impel them to the separation. We hold these truths to be self-evident, that all men are created equal; that they are endowed by their Creator with certain unalienable rights; that among these, are life, liberty, and the pursuit of happiness. That, to secure these rights, governments are instituted among men, deriving their just powers from the consent of the governed; that whenever any form of government becomes destructive of these ends, it is the right of the people to alter or to abolish it, and to institute a new government, laying its foundation on such principles, and organizing its powers in such form, as to them shall seem most likely to effect their safety and happiness. Prudence indeed will dictate that governments long established, should not be changed for light and transient causes; and, accordingly, all experience hath shown, that mankind are more disposed to suffer, while evils are sufferable, than to right

Lower case a to z, 15½ ems

7 POINT No 60

WHEN, in the course of human events, it becomes necessary for one people to dissolve the political bands which have connected them with another, and to assume, among the powers of the earth, the separate and equal station to which the laws of nature and of nature's God entitle them, a decent respect to the opinions of mankind requires that they should declare the causes which impel them to the separation. We hold these truths to be self-evident, that all men are created equal; that they are endowed by their Creator with certain unalienable rights; that among these, are life, liberty, and the pursuit of happiness. That, to secure these rights, governments are instituted among men, deriving their just powers from the consent of the governed; that, whenever any form of government becomes destructive of these ends, it is the right of the people to alter or to abolish it, and to institute a new government, laying its foundation on such principles, and organizing its powers in such form, as to them shall seem

Lower case a to z, 14¾ ems

For other sizes of this series, see pages 48 to 50

8 POINT No 60

WHEN, in the course of human events, it becomes necessary for one people to dissolve the political bands which have connected them with another, and to assume, among the powers of the earth, the separate and equal station to which the laws of nature and of nature's God entitle them, a decent respect to the opinions of mankind requires that they should declare the causes which impel them to the separation. We hold these truths to be self-evident, that all men are created equal; that they are endowed by their Creator with certain unalienable rights; that among these, are life, liberty, and the pursuit of happiness. That, to secure these rights, governments are instituted among men, deriving their just powers from the consent of the governed; that, whenever any form of government becomes destructive of these ends, it is the right of the people to alter or to abolish it, and to institute a new government, laying its foundation on such principles, and organizing its powers in such form, as to them shall seem

Lower case a to z, 13 ems

9 POINT No 60

WHEN, in the course of human events, it becomes necessary for one people to dissolve the political bands which have connected them with another, and to assume, among the powers of the earth, the separate and equal station to which the laws of nature and of nature's God entitle them, a decent respect to the opinions of mankind requires that they should declare the causes which impel them to the separation. We hold these truths to be self-evident, that all men are created equal; that they are endowed by their Creator with certain unalienable rights; that among these are life, liberty, and the pursuit of happiness. That, to secure these rights, governments are instituted among men, deriving their just powers from the consent of the governed; that, whenever any form of government becomes destructive of these ends, it is

Lower case a to z, 12½ ems

AMERICAN PRESS ASSOCIATION SERIES NO 61

6 POINT NO 61

WHEN, in the course of human events, it becomes necessary for one people to dissolve the political bands which have connected them with another, and to assume, among the powers of the earth, the separate and equal station to which the laws of nature and of nature's God entitle them, a decent respect to the opinions of mankind requires that they should declare the causes which impel them to the separation. We hold these truths to be self-evident, that all men are created equal ; that they are endowed by their Creator with certain unalienable rights ; that among these, are life, liberty, and the pursuit of happiness. That, to secure these rights, governments are founded among men, deriving their just powers from the consent of the governed ; that, whenever any form of government becomes destructive of these ends, it is the right of the people to alter or to abolish it, and to institute a new government, laying its foundation on such principles, and organizing its powers in such form, as to them shall seem most likely to effect their safety and happiness. Prudence, indeed, will dictate that governments long established, should not be changed for light and transient causes ; and, accordingly, all experience hath shown, that mankind are more disposed to suffer, while evils are sufferable,

Lower case a to z, 16 $\frac{2}{3}$ ems

7 POINT NO 61

WHEN, in the course of human events, it becomes necessary for one people to dissolve the political bands which have connected them with another, and to assume, among the powers of the earth, the separate and equal station to which the laws of nature and of nature's God entitle them, a decent respect to the opinions of mankind requires that they should declare the causes which impel them to the separation. We hold these truths to be self-evident, that all men are created equal ; that they are endowed by their Creator with certain unalienable rights ; that among these, are life, liberty, and the pursuit of happiness. That, to secure these rights, governments are instituted among men, deriving their just powers from the consent of the governed ; that, whenever any form of government becomes destructive of these ends, it is the right of the people to alter or to abolish it, and to institute a new government, laying its foundation on such principles, and organizing its powers in such form, as to

Lower case a to z, 15 $\frac{2}{3}$ ems*This series also shown on page 51*

8 POINT NO 61

WHEN, in the course of human events, it becomes necessary for one people to dissolve the political bands which have connected them with another, and to assume, among the powers of the earth, the separate and equal station to which the laws of nature and of nature's God entitle them, a decent respect to the opinions of mankind requires that they should declare the causes which impel them to the separation. We hold these truths to be self-evident, that all men are created equal ; that they are endowed by their Creator with certain unalienable rights ; that among these, are life, liberty, and the pursuit of happiness. That, to secure these rights, governments are instituted among men, deriving their just powers from the consent of the governed ; that, whenever any form of government becomes destructive of these ends, it is the right of the people to alter or to abolish it, and to institute a new government, laying its foundation on such principles, and

Lower case a to z, 14 $\frac{1}{2}$ ems

9 POINT NO 61

WHEN, in the course of human events it becomes necessary for one people to dissolve the political bands which connect them with another, and to assume, among the powers of the earth, the separate and equal station to which the laws of nature and of nature's God entitle them, a decent respect to the opinions of mankind requires that they should declare the causes which impel them to the separation. We hold these truths to be self-evident, that all men are created equal ; that they are endowed by their Creator with certain unalienable rights ; that among these, are life, liberty, and the pursuit of happiness. That, to secure these rights, governments are instituted among men, deriving their just powers from the consent of the governed ; that, whenever any form of government

Lower case a to z, 14 $\frac{1}{4}$ ems

SERIES NO 65—NEWSPAPER STYLE

5½ POINT NO 65

WHEN, in the course of human events, it becomes necessary for one people to dissolve the political bands which have connected them with another, and to assume, among the powers of the earth, the separate and equal station to which the laws of nature and of nature's God entitle them, a decent respect to the opinions of mankind requires that they should declare the causes which impel them to the separation. We hold these truths to be self-evident, that all men are created equal; that they are endowed by their Creator with certain unalienable rights; that among these, are life, liberty, and the pursuit of happiness. That, to secure these rights, governments are instituted among men, deriving their just powers from the consent of the governed; that, whenever any government becomes destructive of these ends, it is the right of the people to alter or to abolish it, and to institute a new government, laying its foundation on such principles, and organizing its powers in such form, as to them shall seem most likely to effect their safety and happiness. Prudence, indeed, will dictate that governments long established, should not be changed for light and transient causes; and, accordingly, all experience hath shown, that mankind are more disposed to suffer, while evils are sufferable, than to right themselves by abolishing the forms to which they are accustomed. But, when a long train of abuses and usurpations, pursuing invariably the same object, evinces a design to reduce them under absolute despotism, it is their right, it is their duty, to throw off such government, and to

Lower case a to z, 15¾ ems

6 POINT NO 65

WHEN, in the course of human events, it becomes necessary for one people to dissolve the political bands which have connected them with another, and to assume, among the powers of the earth, the separate and equal station to which the laws of nature and of nature's God entitle them, a decent respect to the opinions of mankind requires that they should declare the causes which impel them to the separation. We hold these truths to be self-evident, that all men are created equal; that they are endowed by their Creator with certain unalienable rights; that among these are life, liberty and the pursuit of happiness. That, to secure these rights, governments are instituted among men, deriving their just powers from the consent of the governed; that, whenever any form of government becomes destructive of these ends, it is the right of the people to alter or to abolish it, and to institute a new government, laying its foundation on such principles and organizing its powers in such form as to them shall seem most likely to effect their safety and happiness. Prudence, indeed, will dictate that governments long established should not be changed for light and transient causes; and, accordingly all experience hath shown that mankind are more disposed to suffer, while evils are sufferable, than to right themselves by abolishing the forms to which they are accustomed. But, when a long train of abuses and usur-

Lower case a to z, 15 ems

For other sizes of this series, see pages 54 and 55

7 POINT NO 65

WHEN, in the course of human events, it becomes necessary for one people to dissolve the political bands which have connected them with another, and to assume, among the powers of the earth, the separate and equal station to which the laws of nature and of nature's God entitle them, a decent respect to the opinions of mankind requires that they should declare the causes which impel them to the separation. We hold these truths to be self-evident, that all men are created equal; that they are endowed by their Creator with certain unalienable rights; that among these, are life, liberty, and the pursuit of happiness. That, to secure these rights, governments are instituted among men, deriving their just powers from the consent of the governed; that, whenever any form of government becomes destructive of these ends, it is the right of the people to alter or to abolish it, and to institute a new government, laying its foundation on such principles, and organizing its powers in such form, as to them shall seem most likely to effect their safety and happiness. Prudence, indeed, will dictate that governments long established should not be changed for light and transient causes; and, accordingly, all experience hath shown, that mankind are more disposed to suffer

Lower case a to z, 13¾ ems

8 POINT NO 65

WHEN, in the course of human events, it becomes necessary for one people to dissolve the political bands which have connected them with another, and to assume, among the powers of the earth, the separate and equal station to which the laws of nature and of nature's God entitle them, a decent respect to the opinions of mankind requires that they should declare the causes which impel them to the separation. We hold these truths to be self-evident, that all men are created equal; that they are endowed by their Creator with certain unalienable rights; that among these, are life, liberty, and the pursuit of happiness. That, to secure these rights, governments are instituted among men, deriving their just powers from the consent of the governed; that, whenever any government becomes destructive of these ends, it is the right of the people to alter or to abolish it, and to institute a new government, laying its foundation on such principles, and organizing its powers in such form, as to them

Lower case a to z, 14 ems

SERIES NO 66—NEWSPAPER STYLE

5½ POINT NO 66

WHEN, in the course of human events, it becomes necessary for one people to dissolve the political bands which have connected them with another, and to assume, among the powers of the earth, the separate and equal station to which the laws of nature and of nature's God entitle them, a decent respect to the opinions of mankind requires that they should declare the causes which impel them to the separation. We hold these truths to be self-evident, that all men are created equal; that they are endowed by their Creator with certain unalienable rights; that among these, are life, liberty, and the pursuit of happiness. That, to secure these rights, governments are instituted among men, deriving their just powers from the consent of the governed; that, whenever any form of government becomes destructive of these ends, it is the right of the people to alter or to abolish it, and to institute a new government, laying its foundation on such principles, and organizing its powers in such form, as to them shall seem most likely to effect their safety and happiness. Prudence, indeed, will dictate that governments long established, should not be changed for light and transient causes; and, accordingly, all experience hath shown, that mankind are more disposed to suffer, while evils are sufferable, than to right themselves by abolishing the forms to which they are accustomed. But, when a long train of abuses and usurpations, pursuing invariably the same object, evinces a design to reduce them under absolute despotism, it is their right, it is their duty, to throw off such government, and to pro-

Lower case a to z, 15 ems

6 POINT NO 66

WHEN, in the course of human events, it becomes necessary for one people to dissolve the political bands which have connected them with another, and to assume, among the powers of the earth, the separate and equal station to which the laws of nature and of nature's God entitle them, a decent respect to the opinions of mankind requires that they should declare the causes which impel them to the separation. We hold these truths to be self-evident, that all men are created equal; that they are endowed by the Creator with certain unalienable rights; that among these, are life, liberty, and the pursuit of happiness. That, to secure these rights, governments are instituted among men, deriving their just powers from the consent of the governed; that, whenever any government becomes destructive of these ends, it is the right of the people to alter or to abolish it, and to institute a new government, laying its foundation on such principles, and organizing its powers in such form, as to them shall seem most likely to effect their safety and happiness. Prudence, indeed, will dictate that governments long established, should not be changed for light and transient causes; and, accordingly, all experience hath shown, that mankind are more disposed to suffer, while evils are sufferable, than to right themselves by abolishing the forms to which they are ac-

Lower case a to z, 15 ems

This series also shown on page 56

7 POINT NO 66

WHEN, in the course of human events, it becomes necessary for one people to dissolve the political bands which have connected them with another, and to assume, among the powers of the earth, the separate and equal station to which the laws of nature and of nature's God entitle them, a decent respect to the opinions of mankind requires that they should declare the causes which impel them to the separation. We hold these truths to be self-evident, that all men are created equal; that they are endowed by their Creator with certain unalienable rights; that among these, are life, liberty and the pursuit of happiness. That, to secure these rights, governments are instituted among men, deriving their just powers from the consent of the governed; that, whenever any form of government becomes destructive of these ends, it is the right of the people to alter or to abolish it, and to institute a new government, laying its foundation on such principles, and organizing its powers in such form, as to them shall seem most likely to effect their safety and happiness. Prudence, indeed, will dictate that governments long established, should not be changed for light and transient causes; and, accordingly, all

Lower case a to z, 14¼ ems

8 POINT NO 66

WHEN, in the course of human events, it becomes necessary for one people to dissolve the political bands which have connected them with another, and to assume, among the powers of the earth, the separate and equal station to which the laws of nature and of nature's God entitle them, a decent respect for the opinions of mankind requires that they should declare the causes which impel them to the separation. We hold these truths to be self-evident, that all men are created equal; that they are endowed by their Creator with certain unalienable rights; that among these, are life, liberty, and the pursuit of happiness. That, to secure these rights, governments are instituted among men, deriving their just powers from the consent of the governed; that, whenever any form of government becomes destructive of these ends, it is the right of the people to alter or to abolish it, and to institute a new government, laying its foundation on such principles, and

Lower case a to z, 14 ems

SERIES NO 67—NEWSPAPER STYLE

5½ POINT NO 67

WHEN, in the course of human events, it becomes necessary for one people to dissolve the political bands which have connected them with another, and to assume, among the powers of the earth, the separate and equal station to which the laws of nature and of nature's God entitle them, a decent respect to the opinions of mankind requires that they should declare the causes which impel them to the separation. We hold these truths to be self-evident, that all men are created equal; that they are endowed by their Creator with certain unalienable rights; that among these, are life, liberty, and the pursuit of happiness. That, to secure these rights, governments are instituted among men, deriving their just powers from the consent of the governed; that, whenever any form of government becomes destructive of these ends, it is the right of the people to alter or to abolish it, and to institute a new government, laying its foundation on such principles, and organizing its powers in such form, as to them shall seem most likely to effect their safety and happiness. Prudence, indeed, will dictate that governments long established should not be changed for light and transient causes; and, accordingly, all experience hath shown, that mankind are more disposed to suffer, while evils are sufferable, than to right themselves by abolishing the forms to which they are accustomed. But, when a long train of abuses and usurpations, pursuing invariably the same object, evinces a design to reduce them under absolute despotism, it is their right, it is their duty, to throw off such government, and to provide new

Lower case a to z, 15½ ems

6 POINT NO 67

WHEN, in the course of human events, it becomes necessary for one people to dissolve the political bands which have connected them with another, and to assume, among the powers of the earth, the separate and equal station to which the laws of nature and of nature's God entitle them, a decent respect to the opinions of mankind requires that they should declare the causes which impel them to the separation. We hold these truths to be self-evident, that all men are created equal; that they are endowed by their Creator with certain unalienable rights; that among these, are life, liberty, and the pursuit of happiness. That, to secure these rights, governments are instituted among men, deriving their just powers from the consent of the governed; that, whenever any form of government becomes destructive of these ends, it is the right of the people to alter or to abolish it, and to institute a new government, laying its foundation on such principles, and organizing its powers in such form, as to them shall seem most likely to effect their safety and happiness. Prudence, indeed, will dictate that governments long established, should not be changed for light and transient causes; and, accordingly, all experience hath shown, that mankind are more disposed to suffer, while evils are sufferable, than to right themselves by abolishing the forms to which they

Lower case a to z, 15½ ems

For other sizes of this series, see pages 58 and 59

7 POINT NO 67

WHEN, in the course of human events, it becomes necessary for one people to dissolve the political bands which have connected them with another, and to assume, among the powers of the earth, the separate and equal station to which the laws of nature and of nature's God entitle them, a decent respect to the opinions of mankind requires that they should declare the causes which impel them to the separation. We hold these truths to be self-evident, that all men are created equal; that they are endowed by their Creator with certain unalienable rights; that among these, are life, liberty, and the pursuit of happiness. That, to secure these rights, governments are instituted among men, deriving their just powers from the consent of the governed; that, whenever any form of government becomes destructive of these ends, it is the right of the people to alter or to abolish it, and to institute a new government, laying its foundation on such principles, and organizing its powers in such form, as to them shall seem most likely to effect their safety and happiness. Prudence, indeed, will dictate that governments long established, should not be changed for light and transient causes; and, accordingly,

Lower case a to z, 14¾ ems

8 POINT NO 67

WHEN, in the course of human events, it becomes necessary for one people to dissolve the political bands which have connected them with another, and to assume, among the powers of the earth, the separate and equal station to which the laws of nature and of nature's God entitle them, a decent respect to the opinions of mankind requires that they should declare the causes which impel them to the separation. We hold these truths to be self-evident, that all men are created equal; that they are endowed by their Creator with certain unalienable rights; that among these, are life, liberty, and the pursuit of happiness. That, to secure these rights, governments are instituted among men, deriving their just powers from the consent of the governed; that, whenever any form of government becomes destructive of these ends, it is the right of the people to alter or to abolish it, and to institute a new government, laying its foundation on such principles, and or-

Lower case a to z, 14 ems

SERIES NO 68—NEWSPAPER STYLE

6 POINT NO 68

WHEN, in the course of human events, it becomes necessary for one people to dissolve the political bands which have connected them with another, and to assume among the powers of the earth, the separate and equal station to which the laws of nature and of nature's God entitle them, a decent respect to the opinions of mankind requires that they should declare the causes which impel them to the separation. We hold these truths to be self-evident, that all men are created equal; that they are endowed by their Creator with certain unalienable rights; that among these, are life, liberty, and the pursuit of happiness. That, to secure these rights, governments are instituted among men, deriving their just powers from the consent of the governed; that, whenever any form of government becomes destructive of these ends, it is the right of the people to alter or to abolish it, and to institute a new government, laying its foundation on such principles, and organizing its powers in such form, as to them shall seem most likely to effect their safety and happiness. Prudence, indeed, will dictate that governments long established, should not be changed for light and transient causes; and, accordingly, all experience hath shown, that mankind are more disposed to suffer, while evils are sufferable, than to right themselves by abol-

Lower case a to z, 17 ems

6 POINT NO 68

WHEN, in the course of human events, it becomes necessary for one people to dissolve the political bands which have connected them with another, and to assume, among the powers of the earth, the separate and equal station to which the laws of nature and of nature's God entitle them, a decent respect to the opinions of mankind requires that they should declare the causes which impel them to the separation. We hold these truths to be self-evident, that all men are created equal; that they are endowed by their Creator with certain unalienable rights; that among these, are life, liberty, and the pursuit of happiness. That, to secure these rights, governments are instituted among men, deriving their just powers from the consent of the governed; that, whenever any form of government becomes destructive of these ends, it is the right of the people to alter or to abolish it, and to institute a new government, laying its foundation on such principles, and organizing its powers in such form, as to them shall seem, most likely to effect their safety and happiness. Prudence, indeed, will dictate that governments long established, should not be changed for light

Lower case a to z, 17 ems

This series also shown on page 60

7 POINT NO 68

WHEN, in the course of human events, it becomes necessary for one people to dissolve the political bands which have connected them with another, and to assume, among the powers of the earth, the separate and equal station to which the laws of nature and of nature's God entitle them, a decent respect for the opinions of mankind requires that they should declare the causes which impel them to the separation. We hold these truths to be self-evident, that all men are created equal; that they are endowed by their Creator with certain unalienable rights; that among these, are life, liberty and the pursuit of happiness. That, to secure these rights, governments are instituted among men, deriving their just powers from the consent of the governed; that, whenever any form of government becomes destructive of these ends, it is the right of the people to alter or to abolish it, and to institute a new government, laying its foundation on such principles, and organizing its powers in such form, as to them shall seem most likely to effect their safety and happiness. Prudence, indeed, will dictate that governments long

Lower case a to z, 15½ ems

8 POINT NO 68

WHEN, in the course of human events, it becomes necessary for one people to dissolve the political bands which have connected them with another, and to assume, among the powers of the earth, the separate and equal station to which the laws of nature and of nature's God entitle them, a decent respect to the opinions of mankind requires that they should declare the causes which impel them to the separation. We hold these truths to be self-evident, that all men are created equal; that they are endowed by their Creator with certain unalienable rights; that among these, are life, liberty, and the pursuit of happiness. That, to secure these rights, governments are instituted among men, deriving their just powers from the consent of the governed; that, whenever any form of government becomes destructive of these ends, it is the right of the people to alter or to abolish it, and to institute a new government, lay-

Lower case a to z, 14½ ems

SELF SPACING MODERN ROMAN—NEWSPAPER STYLE

6 POINT NO 20½

Unit of measure, 12 to Pica

WHEN, in the course of human events, it becomes necessary for one people to dissolve the political bands which have connected them with another, and to assume, among the powers of the earth, the separate and equal station to which the laws of nature and of nature's God entitle them, a due respect to the opinions of mankind requires that they should declare the causes which impel them to the separation. We hold these truths to be self-evident, that all men are created equal; that they are endowed by their Creator with certain unalienable rights; that among these, are life, liberty, and the pursuit of happiness. That, to secure these rights, governments are instituted among men, deriving their just powers from the consent of the governed; that, whenever any government becomes destructive of these ends, it is the right of the people to alter or to abolish it, and to institute a new government, laying its foundation on such principles, and organizing its powers in such form, as to them shall seem most likely to effect their safety and happiness. Prudence, indeed, will dictate that governments long established, should not be changed for light and transient causes; and, accordingly, all experience hath shown, that mankind are more disposed to suffer, while evils are sufferable, than they are to

Lower case a to z, 15½ ems

7 POINT NO 23½

Unit of measure, 11 to Pica

WHEN, in the course of human events, it becomes necessary for one people to dissolve the political bands which have connected them with another, and to assume, among the powers of the earth, the separate and equal station to which the laws of nature and of nature's God entitle them, a decent respect to the opinions of mankind requires that they should declare the causes which impel them to the separation. We hold these truths to be self-evident, that all men are created equal; that they are endowed by their Creator with certain unalienable rights; that among these, are life, liberty, and the pursuit of happiness. That, to secure these rights, governments are instituted among men, deriving their just powers from the consent of the governed; that, whenever any form of government becomes destructive of these ends, it is the right of the people to alter or to abolish it, and to institute a new government, laying its foundation on such principles, and organizing its powers in such form, as to them shall seem

Lower case a to z, 14½ ems

For other sizes, see pages 130 to 135

8 POINT NO 18½

Unit of measure, 10 to Pica

WHEN, in the course of human events, it becomes necessary for one people to dissolve the political bands which have connected them with another, and to assume, among the powers of the earth, the separate and equal station to which the laws of nature and of nature's God entitle them, a decent respect to the opinions of mankind requires that they should declare the causes which impel them to the separation. We hold these truths to be self-evident, that all men are created equal; that they are endowed by their Creator with certain unalienable rights; that among these, are life, liberty, and the pursuit of happiness. That, to secure these rights, governments are instituted among men, deriving their just powers from the consent of the governed; that, whenever any form of government becomes destructive of these ends, it is the right of the people to alter or to abolish it, and to institute a new government, laying its foundation on

Lower case a to z, 14¼ ems

9 POINT NO 32½

Unit of measure, 9 to Pica

WHEN, in the course of human events, it becomes necessary for one people to dissolve the political bands which have connected them with another, and to assume, among the powers of the earth, the separate and equal station to which the laws of nature and of nature's God entitle them, a decent respect to the opinions of mankind requires that they should declare the causes which impel them to the separation. We hold these truths to be self-evident, that all men are created equal; that they are endowed by their Creator with certain unalienable rights; that among these are life, liberty and the pursuit of happiness. That, to secure these rights, governments are instituted among men, deriving their just powers from the consent of the governed; that, whenever any form of government

Lower case a to z, 13¾ ems

For description of Self Spacing Type, see pages 128 and 129

OLD STYLE ROMANS SHOWN BY SIZES

Same faces shown by series on pages 101 to 127

5 POINT OLD STYLE NO 79 C

WHEN, in the course of human events, it becomes necessary for one people to dissolve the political bands which have connected them with another, and to assume, among the powers of the earth, the separate and equal station to which the laws of nature and of nature's God entitle them, a decent respect to the opinions of mankind requires that they should declare the causes which impel them to the separation. We hold these truths to be self-evident, that all men are created equal; that they are endowed by their Creator with certain unalienable rights; that among these, are life, liberty, and the pursuit of happiness. That, to secure these rights, governments are instituted among men, deriving their just powers from the consent of the governed; that, *whenever any form of government becomes de-*

Lower case a to z, 14¼ ems

ABCDEFGHIJKLMN OPQRSTUVWXYZ
1234567890

A 5½ POINT OLD STYLE NO 80

WHEN, in the course of human events, it becomes necessary for one people to dissolve the political bands which have connected them with another, and to assume, among the powers of the earth, the separate and equal station to which the laws of nature and of nature's God entitle them, a decent respect to the opinions of mankind requires that they should declare the causes which impel them to the separation. We hold these truths to be self-evident, that all men are created equal; that they are endowed by their Creator with certain unalienable rights; that among these, are life, liberty, and the pursuit of happiness. That, to secure these rights

Lower case a to z, 15 ems

ABCDEFGHIJKLMN OPQRSTUVWXYZ
1234567890

5½ POINT OLD STYLE NO 73 E

WHEN, in the course of human events, it becomes necessary for one people to dissolve the political bands which have connected them with another, and to assume, among the powers of the earth, the separate and equal station to which the laws of nature and of nature's God entitle them, a decent respect to the opinions of mankind requires that they should declare the causes which impel them to the separation. We hold these truths to be self-evident, that all men are created equal; that they are endowed by their Creator with certain unalienable rights; that among these, are life, liberty, and the pursuit of happiness. That, to secure these rights, governments are instituted among men, deriving their just powers from the consent of the governed; that, whenever any form of government becomes destructive of these ends, it is the right of the people to alter or to abolish it, and to institute a new government, laying its foundation on such principles, and organizing its powers in such form, as to them shall seem most likely to effect their safety and happiness. *Prudence, indeed, will dictate that governments*

Lower case a to z, 16½ ems

ABCDEFGHIJKLMN OPQRSTUVWXYZ
1234567890

6 POINT OLD STYLE NO 71 C

WHEN, in the course of human events, it becomes necessary for one people to dissolve the political bands which have connected them with another, and to assume, among the powers of the earth, the separate and equal station to which the laws of nature and of nature's God entitle them, a decent respect to the opinions of mankind requires that they should declare the causes which impel them to the separation. We hold these truths to be self-evident, that all men are created equal; that they are endowed by their Creator with certain unalienable rights; that among these, are life, liberty, and the pursuit of happiness. That, to secure these rights, governments are instituted among men, deriving their just powers from the consent of the governed; that, whenever any government becomes destructive of these ends, it is the right of the people to alter or to abolish it, and to institute a new government, laying its foundation on such principles, and organizing its powers in such form, as to them shall seem most likely to effect their safety and happiness. *Pru-*

Lower case a to z, 13½ ems

ABCDEFGHIJKLMN OPQRSTUVWXYZ
1234567890

6 POINT OLD STYLE NO 79 A

WHEN, in the course of human events, it becomes necessary for one people to dissolve the political bands which have connected them with another, and to assume, among the powers of the earth, the separate and equal station to which the laws of nature and of nature's God entitle them, a decent respect to the opinions of mankind requires that they should declare the causes which impel them to the separation. We hold these truths to be self-evident, that all men are created equal; that they are endowed by their Creator with certain unalienable rights; that among these, are life, liberty, and the pursuit of happiness. That, to secure these rights, governments are instituted among men, deriving their just powers from the consent of the governed; that, whenever any form of government becomes destructive of these ends, it is the right of the people to alter or to abolish it, and to institute a new government, laying its foundation on such principles, and organizing its powers in such form, as to them shall seem

Lower case a to z, 13¾ ems

ABCDEFGHIJKLMN OPQRSTUVWXYZ
1234567890

6 POINT FRENCH OLD STYLE NO 2

WHEN, in the course of human events, it becomes necessary for one people to dissolve the political bands which have connected them with another, and to assume, among the powers of the earth, the separate and equal station to which the laws of nature and of nature's God entitle them, a decent respect to the opinions of mankind requires that they should declare the causes which impel them to the separation. We hold these truths to be self-evident, that all men are created equal; that they are endowed by their Creator with certain unalienable rights; that among these, are life, liberty, and the pursuit of happiness. That, to secure these rights, governments are instituted among men, deriving their just powers from the consent of the governed; that, whenever any form of government becomes destructive of these ends, it is the right of the people to alter or to abolish it, and to institute a new government, laying its foundation on such principles, and organizing its powers in such form, as to them shall seem most likely to effect their safety and happiness. Prudence, indeed, will dictate that governments long established, should not be changed for light and transient causes;

Lower case a to z, 14 ems

ABCDEFGHIJKLMN OPQRSTUVWXYZ

1234567890

6 POINT CUSHING

WHEN, in the course of human events, it becomes necessary for one people to dissolve the political bands which have connected them with another, and to assume, among the powers of the earth, the separate and equal station to which the laws of nature and of nature's God entitle them, a decent respect to the opinions of mankind requires that they should declare the causes which impel them to the separation. We hold these truths to be self-evident, that all men are created equal; that they are endowed by their Creator with certain unalienable rights; that among these, are life, liberty, and the pursuit of happiness. That, to secure these rights, governments are instituted among men, deriving their just powers from the consent of the governed; that, whenever any form of government becomes destructive of these ends, it is the right of the people to alter or abolish it, and to institute a new government, laying its foundations on such principles, and organizing its powers in such form, as to them shall seem most likely to effect their safety and happiness. Prudence, indeed, will dictate that governments long established should not be changed for light and tran-

Lower case a to z, 13 $\frac{7}{8}$ ems

ABCDEFGHIJKLMN OPQRSTUVWXYZ

1234567890

6 POINT OLD STYLE NO 84

WHEN, in the course of human events, it becomes necessary for one people to dissolve the political bands which have connected them with another, and to assume, among the powers of the earth, the separate and equal station to which the laws of nature and of nature's God entitle them, a decent respect to the opinions of mankind requires that they should declare the causes which impel them to the separation. We hold these truths to be self-evident, that all men are created equal; that they are endowed by their Creator with certain unalienable rights; that among these, are life, liberty, and the pursuit of happiness. That, to secure these rights, governments are instituted among men, deriving their just powers from the consent of the governed; that, whenever any form of government becomes destructive of these ends, it is the right of the people to alter or to abolish it, and to institute a new government, laying its foundation on such principles, and organizing its powers in such form, as to them shall seem most likely to effect their safety and happiness. Prudence, indeed, will dictate that

Lower case a to z, 15 ems

ABCDEFGHIJKLMN OPQRSTUVWXYZ

1234567890

6 POINT OLD STYLE NO 77

WHEN, in the course of human events, it becomes necessary for one people to dissolve the political bands which have connected them with another, and to assume, among the powers of the earth, the separate and equal station to which the laws of nature and of nature's God entitle them, a decent respect to the opinions of mankind requires that they should declare the causes which impel them to the separation. We hold these truths to be self-evident, that all men are created equal; that they are endowed by their Creator with certain unalienable rights; that among these, are life, liberty, and the pursuit of happiness. That, to secure these rights, governments are instituted among men, deriving their just powers from the consent of the governed; that, whenever any form of government becomes destructive of these ends, it is the right of the people to institute a new government, laying its foundation on such principles, and organizing its powers in such form, as to them shall seem most likely to effect their safety and happiness. Prudence, indeed, will dictate that governments long

Lower case a to z, 15 $\frac{1}{4}$ ems

ABCDEFGHIJKLMN OPQRSTUVWXYZ

1234567890

6 POINT OLD STYLE NO 83 ^E

WHEN, in the course of human events, it becomes necessary for one people to dissolve the political bands which have connected them with another, and to assume, among the powers of the earth, the separate and equal station to which the laws of nature and of nature's God entitle them, a decent respect to the opinions of mankind requires that they should declare the causes which impel them to the separation. We hold these truths to be self-evident, that all men are created equal; that they are endowed by their Creator with certain unalienable rights; that among these, are life, liberty, and the pursuit of happiness. That, to secure these rights, governments are instituted among men, deriving their just powers from the consent of the governed; that, whenever any form of government becomes destructive of these ends, it is the right of the people to alter or to abolish it, and to institute a new government, laying its foundation on such principles, and organizing its powers in such form, as to them shall seem most likely to effect their safety and happiness. Pru-

Lower case a to z, 15¼ ems

ABCDEFGHIJKLMN O PQRSTU VWXYZ

1234567890

6 POINT OLD STYLE NO 72 ^{C-E}

WHEN, in the course of human events, it becomes necessary for one people to dissolve the political bands which have connected them with another, and to assume, among the powers of the earth, the separate and equal station to which the laws of nature and of nature's God entitle them, a decent respect to the opinions of mankind requires that they should declare the causes which impel them to the separation. We hold these truths to be self-evident, that all men are created equal; that they are endowed by their Creator with certain unalienable rights; that among these, are life, liberty, and the pursuit of happiness. That, to secure these rights, governments are instituted among men, deriving their just powers from the consent of the governed; that, whenever any government becomes destructive of these ends, it is the right of the people to alter or to abolish it, and to institute a new government, laying its foundation on such principles, and organizing its powers in such form, as to them shall seem most likely to effect their safety and happi-

Lower case a to z, 15½ ems

ABCDEFGHIJKLMN O PQRSTU VWXYZ

1234567890

6 POINT SELF SPACING OLD STYLE NO 30 ^B

Unit of measure, 12 to Pica

WHEN, in the course of human events, it becomes necessary for one people to dissolve the political bands which have connected them with another, and to assume, among the powers of the earth, the separate and equal station to which the laws of nature and of nature's God entitle them, a decent respect to the opinions of mankind requires that they should declare the causes which impel them to the separation. We hold these truths to be self-evident, that all men are created equal; that they are endowed by their Creator with certain unalienable rights; that among these, are life, liberty, and the pursuit of happiness. That, to secure these rights, governments are instituted among men, deriving their just powers from the consent of the governed; that, whenever any form of government becomes destructive of these ends, it is the right of the people to alter or to abolish it, and to institute a new government, laying its foundation on such principles, and organizing its powers in such form, as to them shall seem most likely to effect their safety

Lower case a to z, 15½ ems

ABCDEFGHIJKLMN O PQRSTU VWXYZ

1234567890

6 POINT OLD STYLE NO 73 ^E

WHEN, in the course of human events, it becomes necessary for one people to dissolve the political bands which have connected them with another, and to assume, among the powers of the earth, the separate and equal station to which the laws of nature and of nature's God entitle them, a decent respect to the opinions of mankind requires that they should declare the causes which impel them to the separation. We hold these truths to be self-evident, that all men are created equal; that they are endowed by their Creator with certain unalienable rights; that among these, are life, liberty, and the pursuit of happiness. That, to secure these rights, governments are instituted among men, deriving their just powers from the consent of the governed; that, whenever any form of government becomes destructive of these ends, it is the right of the people to alter or to abolish it, and to institute a new government, laying its foundation on such principles, and organizing its powers in such form, as to them shall seem most

Lower case a to z, 16½ ems

ABCDEFGHIJKLMN O PQRSTU VWXYZ

1234567890

6 POINT OLD STYLE NO 325 ^B

WHEN, in the course of human events, it becomes necessary for one people to dissolve the political bands which have connected them with another, and to assume, among the powers of the earth, the separate and equal station to which the laws of nature and of nature's God entitle them, a decent respect to the opinions of mankind requires that they should declare the causes which impel them to the separation. We hold these truths to be self-evident, that all men are created equal; that they are endowed by their Creator with certain unalienable rights; that among these, are life, liberty, and the pursuit of happiness. That, to secure these rights, governments are instituted among men, deriving their just powers from the consent of the governed; that, whenever any form of government becomes destructive of these ends, it is the right of the people to alter or to abolish it, and to institute a new government, laying its foundation on such principles, and organizing its powers in such form, as to them shall seem

Lower case a to z, 16 $\frac{2}{3}$ emsABCDEFGHIJKLMN**OP**QRSTUVWXYZ

1234567890

6 POINT SELF SPACING OLD STYLE NO 27 ^B

Unit of measure, 11 to Pica

WHEN, in the course of human events, it becomes necessary for one people to dissolve the political bands which have connected them with another, and to assume, among the powers of the earth, the separate and equal station to which the laws of nature and of nature's God entitle them, a decent respect to the opinions of mankind requires that they should declare the causes which impel them to the separation. We hold these truths to be self-evident, that all men are created equal; that they are endowed by their Creator with certain unalienable rights; that among these, are life, liberty, and the pursuit of happiness. That, to secure these rights, governments are instituted among men, deriving their just powers from the consent of the governed; that, whenever any government becomes destructive of these ends, it is the right of the people to alter or to abolish it, and to institute a new government, laying its foundation on such principles, and organizing

Lower case a to z, 17 ems

ABCDEFGHIJKLMN**OP**QRSTUVWXYZ

1234567890

6 POINT CAXTON OLD STYLE ^E

WHEN, in the course of human events, it becomes necessary for one people to dissolve the political bands which have connected them with another, and to assume, among the powers of the earth, the equal station to which the laws of nature and of nature's God entitle them, a decent respect to the opinions of mankind requires that they should declare the causes which impel them to the separation. We hold these truths to be self-evident, that all men are created equal; that they are endowed by their Creator with certain unalienable rights; that among these, are life, liberty, and the pursuit of happiness. That, to secure these rights, governments are instituted among men, deriving their just powers from the consent of the governed; that whenever any form of government becomes destructive of these ends, it is the right of the people to alter or to abolish it, and to institute a new government,

Lower case a to z, 18 $\frac{3}{4}$ emsABCDEFGHIJKLMN**OP**QRSTUVWXYZ

1234567890

7 POINT OLD STYLE NO 79 ^A

WHEN, in the course of human events, it becomes necessary for one people to dissolve the political bands which have connected them with another, and to assume, among the powers of the earth, the separate and equal station to which the laws of nature and of nature's God entitle them, a decent respect to the opinions of mankind requires that they should declare the causes which impel them to the separation. We hold these truths to be self-evident, that all men are created equal; that they are endowed by their Creator with certain unalienable rights; that among these, are life, liberty, and the pursuit of happiness. That, to secure these rights, governments are instituted among men, deriving their just powers from the consent of the governed; that whenever any form of government becomes destructive of these ends, it is the right of the people to alter or to abolish it, and to institute a new government,

Lower case a to z, 13 ems

ABCDEFGHIJKLMN**OP**QRSTUVWXYZ

1234567890

7 POINT OLD STYLE NO 83 ^ε

WHEN, in the course of human events, it becomes necessary for one people to dissolve the political bands which have connected them with another, and to assume, among the powers of the earth, the separate and equal station to which the laws of nature and of nature's God entitle them, a decent respect to the opinions of mankind requires that they should declare the causes which impel them to the separation. We hold these truths to be self-evident, that all men are created equal; that they are endowed by their Creator with certain unalienable rights; that among these, are life, liberty, and the pursuit of happiness. That, to secure these rights, governments are instituted among men, deriving their just powers from the consent of the governed; that, whenever *any form of government becomes destructive of these ends, it is the right of the*

Lower case a to z, 14 ems

ABCDEFGHIJKLMNOPQRSTUVWXYZ
1234567890

7 POINT FRENCH OLD STYLE NO 2 ^φ

WHEN, in the course of human events, it becomes necessary for one people to dissolve the political bands which have connected them with another, and to assume, among the powers of the earth, the separate and equal station to which the laws of nature and of nature's God entitle them, a decent respect to the opinions of mankind requires that they should declare the causes which impel them to the separation. We hold these truths to be self-evident, that all men are created equal; that they are endowed by their Creator with certain unalienable rights; that among these, are life, liberty, and the pursuit of happiness. That, to secure these rights, governments are instituted among men, deriving their just powers from the consent of the governed; that, whenever *any form of government becomes destructive of these ends, it is the right of*

Lower case a to z, 14½ ems

ABCDEFGHIJKLMNOPQRSTUVWXYZ
1234567890

7 POINT OLD STYLE NO 84 ^ε

WHEN, in the course of human events, it becomes necessary for one people to dissolve the political bands which have connected them with another, and to assume, among the powers of the earth, the separate and equal station to which the laws of nature and of nature's God entitle them, a decent respect to the opinions of mankind requires that they should declare the causes which impel them to the separation. We hold these truths to be self-evident, that all men are created equal; that they are endowed by their Creator with certain unalienable rights; that among these, are life, liberty, and the pursuit of happiness. That, to secure these rights, governments are instituted among men, deriving their just powers from the consent of the governed; that, whenever *any form of government becomes destructive of these ends, it is the right of*

Lower case a to z, 14¼ ems

ABCDEFGHIJKLMNOPQRSTUVWXYZ
1234567890

7 POINT OLD STYLE NO 77 ^ο

WHEN, in the course of human events, it becomes necessary for one people to dissolve the political bands which have connected them with another, and to assume, among the powers of the earth, the separate and equal station to which the laws of nature and of nature's God entitle them, a decent respect to the opinions of mankind requires that they should declare the causes which impel them to the separation. We hold these truths to be self-evident, that all men are created equal; that they are endowed by their Creator with certain unalienable rights; that among these, are life, liberty, and the pursuit of happiness. That, to secure these rights, governments are instituted among men, deriving their just powers from the consent of the governed; that, whenever *any government becomes destructive of these*

Lower case a to z, 14 4-5 ems

ABCDEFGHIJKLMNOPQRSTUVWXYZ
1234567890

7 POINT OLD STYLE NO 72 ^{c-e}

WHEN, in the course of human events, it becomes necessary for one people to dissolve the political bands which have connected them with another, and to assume, among the powers of the earth, the separate and equal station to which the laws of nature and of nature's God entitle them, a decent respect to the opinions of mankind requires that they should declare the causes which impel them to the separation. We hold these truths to be self-evident, that all men are created equal; that they are endowed by their Creator with certain unalienable rights; that among these, are life, liberty, and the pursuit of happiness. That, to secure these rights, governments are instituted among men, deriving their just powers from the consent of the governed; that, whenever any form of government becomes destruc-

Lower case a to z, 14¾ ems

ABCDEFGHIJKLMNOPQRSTUVWXYZ

1234567890

7 POINT OLD STYLE NO 325 ⁸

WHEN, in the course of human events, it becomes necessary for one people to dissolve the political bands which have connected them with another, and to assume, among the powers of the earth, the separate and equal station to which the laws of nature and of nature's God entitle them, a decent respect to the opinions of mankind requires that they should declare the causes which impel them to the separation. We hold these truths to be self-evident, that all men are created equal; that they are endowed by their Creator with certain unalienable rights; that among these, are life, liberty, and the pursuit of happiness. That, to secure these rights, governments are instituted among men, deriving their just powers from the consent of the governed; that whenever any form of government

Lower case a to z, 15 ems

ABCDEFGHIJKLMNOPQRSTUVWXYZ

1234567890

7 POINT OLD STYLE NO 73 ^ε

WHEN, in the course of human events, it becomes necessary for one people to dissolve the political bands which have connected them with another, and to assume, among the powers of the earth, the separate and equal station to which the laws of nature and of nature's God entitle them, a decent respect to the opinions of mankind requires that they should declare the causes which impel them to the separation. We hold these truths to be self-evident, that all men are created equal; that they are endowed by their Creator with certain unalienable rights; that among these, are life, liberty, and the pursuit of happiness. That, to secure these rights, governments are instituted among men, deriving their just powers from the consent of the governed; that, whenever any form of government becomes

Lower case a to z, 15½ ems

ABCDEFGHIJKLMNOPQRSTUVWXYZ

1234567890

8 POINT OLD STYLE NO 71 ^o

WHEN, in the course of human events, it becomes necessary for one people to dissolve the political bands which have connected them with another, and to assume, among the powers of the earth, the separate and equal station to which the laws of nature and of nature's God entitle them, a decent respect to the opinions of mankind requires that they should declare the causes which impel them to the separation. We hold these truths to be self-evident, that all men are created equal; that they are endowed by their Creator with certain unalienable rights; that among these, are life, liberty, and the pursuit of happiness. That, to secure these rights, governments are instituted among men, deriving their just powers from the consent of the governed; that, whenever any form

Lower case a to z, 11½ ems

ABCDEFGHIJKLMNOPQRSTUVWXYZ

1234567890

8 POINT CUSHING MONOTONE

WHEN, in the course of human events, it becomes necessary for one people to dissolve the political bands which have connected them with another, and to assume, among the powers of the earth, the separate and equal station to which the laws of nature and of nature's God entitle them, a decent respect to the opinions of mankind requires that they should declare the causes which impel them to the separation. We hold these truths to be self-evident, that all men are created equal; that they are endowed by their Creator with certain unalienable rights; that among these, are life, liberty, and the pursuit of happiness. That, to secure these rights, governments are insti-

Lower case a to z, 12¾ ems

ABCDEFGHIJKLMNOPQRSTUVWXYZ
1234567890

8 POINT OLD STYLE NO 79

WHEN, in the course of human events, it becomes necessary for one people to dissolve the political bands which have connected them with another, and to assume, among the powers of the earth, the separate and equal station to which the laws of nature and of nature's God entitle them, a decent respect to the opinions of mankind requires that they should declare the causes which impel them to the separation. We hold these truths to be self-evident, that all men are created equal; that they are endowed by their Creator with certain unalienable rights; that among these, are life, liberty, and the pursuit of happiness. That, to secure these rights, governments

Lower case a to z, 12⅔ ems

ABCDEFGHIJKLMNOPQRSTUVWXYZ
1234567890

8 POINT FRENCH ELZEVIR NO 1

WHEN, in the course of human events, it becomes necessary for one people to dissolve the political bands which have connected them with another, and to assume, among the powers of the earth, the separate and equal station to which the laws of nature and of nature's God entitle them, a decent respect to the opinions of mankind requires that they should declare the causes which impel them to the separation. We hold these truths to be self-evident, that all men are created equal; that they are endowed by their Creator with certain unalienable rights; that among these, are life, liberty, and the pursuit of happiness. That, to secure these rights, governments

Lower case a to z, 12⅔ ems

ABCDEFGHIJKLMNOPQRSTUVWXYZ
1234567890

8 POINT CUSHING

WHEN, in the course of human events, it becomes necessary for one people to dissolve the political bands which have connected them with another, and to assume, among the powers of the earth, the separate and equal station to which the laws of nature and of nature's God entitle them, a decent respect to the opinions of mankind requires that they should declare the causes which impel them to the separation. We hold these truths to be self-evident, that all men are created equal; that they are endowed by their Creator with certain unalienable rights; that among these, are life, liberty, and the pursuit of happiness. That, to secure these rights, govern-

Lower case a to z, 12⅞ ems

ABCDEFGHIJKLMNOPQRSTUVWXYZ
1234567890

8 POINT FRENCH OLD STYLE NO 2 F

WHEN, in the course of human events, it becomes necessary for one people to dissolve the political bands which have connected them with another, and to assume, among the powers of the earth, the separate and equal station to which the laws of nature and of nature's God entitle them, a decent respect to the opinions of mankind requires that they should declare the causes which impel them to the separation. We hold these truths to be self-evident, that all men are created equal; that they are endowed by their Creator with certain unalienable rights; that *among these, are life, liberty, and the pursuit of happiness. That, to secure*

Lower case a to z, 13¾ ems

ABCDEFGHIJKLMNOPQRSTUVWXYZ

1234567890

8 POINT OLD STYLE NO 77 °

WHEN, in the course of human events, it becomes necessary for one people to dissolve the political bands which have connected them with another, and to assume, among the powers of the earth, the separate and equal station to which the laws of nature and of nature's God entitle them, a decent respect to the opinions of mankind requires that they should declare the causes which impel them to the separation. We hold these truths to be self-evident, that all men are created equal; that they are endowed by their Creator with certain unalienable rights; *that among these, are life, liberty, and the pursuit of happiness. That,*

Lower case a to z, 13¾ ems

ABCDEFGHIJKLMNOPQRSTUVWXYZ

1234567890

8 POINT OLD STYLE NO 72 ° E

WHEN, in the course of human events, it becomes necessary for one people to dissolve the political bands which have connected them with another, and to assume, among the powers of the earth, the separate and equal station to which the laws of nature and of nature's God entitle them, a decent respect to the opinions of mankind requires that they should declare the causes which impel them to the separation. We hold these truths to be self-evident, that all men are created equal; that they are endowed by their Creator with certain unalienable *rights; that among these, are life, liberty, and the pursuit of happi-*

Lower case a to z, 14 ems

ABCDEFGHIJKLMNOPQRSTUVWXYZ

1234567890

8 POINT OLD STYLE NO 84 ° E

WHEN, in the course of human events, it becomes necessary for one people to dissolve the political bands which have connected them with another, and to assume, among the powers of the earth, the separate and equal station to which the laws of nature and of nature's God entitle them, a decent respect to the opinions of mankind requires that they should declare the causes which impel them to the separation. We hold these truths to be self-evident, that all men are created equal; that they are endowed by their Creator with certain *unalienable rights; that among these, are life, liberty, and the pursuit of*

Lower case a to z, 14 ems

ABCDEFGHIJKLMNOPQRSTUVWXYZ

1234567890

8 POINT OLD STYLE NO 83 ^ε

WHEN, in the course of human events, it becomes necessary for one people to dissolve the political bands which have connected them with another, and to assume, among the powers of the earth, the separate and equal station to which the laws of nature and of nature's God entitle them, a decent respect to the opinions of mankind requires that they should declare the causes which impel them to the separation. We hold these truths to be self-evident, that all men are created equal; that they are endowed by their Creator with certain *unalienable rights; that among these, are life, liberty, and the pur-*

Lower case a to z, 14 ems

ABCDEFGHIJKLMNOPQRSTUVWXYZ
1234567890

8 POINT SELF SPACING OLD STYLE NO 22 ^ε

Unit of measure, 10 to Pica

WHEN, in the course of human events, it becomes necessary for one people to dissolve the political bands which have connected them with another, and to assume, among the powers of the earth, the separate and equal station to which the laws of nature and of nature's God entitle them, a decent respect to the opinions of mankind requires that they should declare the causes which impel them to the separation. We hold these truths to be self-evident, that all men are created equal; that they are endowed by their Creator with certain *unalienable rights; that among these, are life, liberty, and the pur-*

Lower case a to z, 14 $\frac{1}{8}$ ems

ABCDEFGHIJKLMNOPQRSTUVWXYZ
1234567890

8 POINT OLD STYLE NO 325 ^ε

WHEN, in the course of human events, it becomes necessary for one people to dissolve the political bands which have connected them with another, and to assume, among the powers of the earth, the separate and equal station to which the laws of nature and of nature's God entitle them, a decent respect to the opinions of mankind requires that they should declare the causes which impel them to the separation. We hold these truths to be self-evident, that all men are created equal; that they are endowed by their Creator with *certain unalienable rights; that among these, are life, liberty, and*

Lower case a to z, 14 $\frac{1}{2}$ ems

ABCDEFGHIJKLMNOPQRSTUVWXYZ
1234567890

8 POINT CAXTON OLD STYLE ^ε

WHEN, in the course of human events, it becomes necessary for one people to dissolve the political bands which have connected them with another, and to assume, among the powers of the earth, the separate and equal station to which the laws of nature and of nature's God entitle them, a decent respect to the opinions of mankind requires that they should declare the causes which impel them to the separation. We hold these truths to be self-evident, that all men are created *equal; that they are endowed by their Creator with un-*

Lower case a to z, 16 $\frac{1}{2}$ ems

ABCDEFGHIJKLMNOPQRSTUVWXYZ
1234567890

9 POINT OLD STYLE NO 71 °

WHEN, in the course of human events, it becomes necessary for one people to dissolve the political bands which have connected them with another, and to assume, among the powers of the earth, the separate and equal station to which the laws of nature and of nature's God entitle them, a decent respect to the opinions of mankind requires that they should declare the causes which impel them to the separation. We hold these truths to be self-evident, that all men are created equal; that they are endowed by *their Creator with certain unalienable rights; that among these, are life,*

Lower case a to z, 11 2-5 ems

ABCDEFGHIJKLMNOPQRSTUVWXYZ

1234567890

9 POINT OLD STYLE NO 79 °

WHEN, in the course of human events, it becomes necessary for one people to dissolve the political bands which have connected them with another, and to assume, among the powers of the earth, the separate and equal station to which the laws of nature and of nature's God entitle them, a decent respect to the opinions of mankind requires that they should declare the causes which impel them to the separation. We hold these truths to be self-evident, that all men are *created equal; that they are endowed by their Creator with certain*

Lower case a to z, 12 1/2 ems

ABCDEFGHIJKLMNOPQRSTUVWXYZ

1234567890

9 POINT OLD STYLE NO 77 °

WHEN, in the course of human events, it becomes necessary for one people to dissolve the political bands which have connected them with another, and to assume, among the powers of the earth, the separate and equal station to which the laws of nature and of nature's God entitle them, a decent respect to the opinions of mankind requires that they should declare the causes which impel them to the separation. We hold these truths to be self-evident, that all *men are created equal; that they are endowed by their Creator with*

Lower case a to z, 13 ems

ABCDEFGHIJKLMNOPQRSTUVWXYZ

1234567890

9 POINT OLD STYLE NO 83 °

WHEN, in the course of human events, it becomes necessary for one people to dissolve the political bands which have connected them with another, and to assume, among the powers of the earth, the separate and equal station to which the laws of nature and of nature's God entitle them, a decent respect to the opinions of mankind requires that they should declare the causes which impel them to the separation. We hold these truths to be self-evident, that all *men are created equal; that they are en-*

Lower case a to z, 13 1/4 ems

ABCDEFGHIJKLMNOPQRSTUVWXYZ

1234567890

9 POINT OLD STYLE NO 72 c-e

WHEN, in the course of human events, it becomes necessary for one people to dissolve the political bands which have connected them with another, and to assume, among the powers of the earth, the separate and equal station to which the laws of nature and of nature's God entitle them, a decent respect to the opinions of mankind requires that they should declare the causes which impel them to the separation. We hold these truths to be self-evident, that all men are created equal; that they are endowed

Lower case a to z, 13½ ems

ABCDEFGHIJKLMN**OP**QRSTUVWXYZ
1234567890

9 POINT SELF SPACING OLD STYLE NO 28 b Unit of measure, 9 to Pica

WHEN, in the course of human events, it becomes necessary for one people to dissolve the political bands which have connected them with another, and to assume, among the powers of the earth, the separate and equal station to which the laws of nature and of nature's God entitle them, a decent respect to the opinions of mankind requires that they should declare the causes which impel them to the separation. We hold these truths to be self-evident, that all men are created equal; that

Lower case a to z, 13¾ ems

ABCDEFGHIJKLMN**OP**QRSTUVWXYZ
1234567890

9 POINT OLD STYLE NO 325 b

WHEN, in the course of human events, it becomes necessary for one people to dissolve the political bands which have connected them with another, and to assume, among the powers of the earth, the separate and equal station to which the laws of nature and of nature's God entitle them, a decent respect to the opinions of mankind requires that they should declare the causes which impel them to the separation. We hold these truths to be self-evident, that all men are created equal;

Lower case a to z, 14 ems

ABCDEFGHIJKLMN**OP**QRSTUVWXYZ
1234567890

10 POINT OLD STYLE NO 71 c

WHEN, in the course of human events, it becomes necessary for one people to dissolve the political bands which have connected them with another, and to assume, among the powers of the earth, the separate and equal station to which the laws of nature and of nature's God entitle them, a decent respect to the opinions of mankind requires that they should declare the causes which impel them to the separation. We hold these truths to be self-evident, that all men are created equal;

Lower case a to z, 11¼ ems

ABCDEFGHIJKLMN**OP**QRSTUVWXYZ
1234567890

10 POINT CUSHING ^A

WHEN, in the course of human events, it becomes necessary for one people to dissolve the political bands which have connected them with another, and to assume, among the powers of the earth, the separate and equal station to which the laws of nature and of nature's God entitle them, a decent respect to the opinions of mankind requires that they should declare the causes which impel them to the separation. *We hold these truths to be self-evident, that all*

Lower case a to z, 11¼ ems

ABCDEFGHIJKLMNOPQRSTUVWXYZ
1234567890

10 POINT FRENCH ELZEVIR NO 1 ^A

WHEN, in the course of human events, it becomes necessary for one people to dissolve the political bands which have connected them with another, and to assume, among the powers of the earth, the separate and equal station to which the laws of nature and of nature's God entitle them, a decent respect to the opinions of mankind requires that they should declare the causes which impel them to the separation. *We hold these truths to be self-evident*

Lower case a to z, 12 ems

ABCDEFGHIJKLMNOPQRSTUVWXYZ
1234567890

10 POINT OLD STYLE NO 79 ^A

WHEN, in the course of human events, it becomes necessary for one people to dissolve the political bands which have connected them with another, and to assume, among the powers of the earth, the separate and equal station to which the laws of nature and of nature's God entitle them, a decent respect to the opinions of mankind requires that they should declare the causes which impel them to the separation. *We hold these truths to be self-*

Lower case a to z, 12 ems

ABCDEFGHIJKLMNOPQRSTUVWXYZ
1234567890

10 POINT OLD STYLE NO 77 ^C

WHEN, in the course of human events, it becomes necessary for one people to dissolve the political bands which have connected them with another, and to assume, among the powers of the earth, the separate and equal station to which the laws of nature and of nature's God entitle them, a decent respect to the opinions of mankind requires that they should declare the causes which impel them to the separation. *We hold these truths*

Lower case a to z, 12 ems

ABCDEFGHIJKLMNOPQRSTUVWXYZ
1234567890

10 POINT CUSHING MONOTONE ^A

WHEN, in the course of human events, it becomes necessary for one people to dissolve the political bands which have connected them with another, and to assume, among the powers of the earth, the separate and equal station to which the laws of nature and of nature's God entitle them, a decent respect to the opinions of mankind requires that they should declare the causes which impel them to the separation. We hold these

Lower case a to z, 12¼ ems

ABCDEFGHIJKLMNOPQRSTUVWXYZ
1234567890

10 POINT OLD STYLE NO 84 ^E

WHEN, in the course of human events, it becomes necessary for one people to dissolve the political bands which have connected them with another, and to assume, among the powers of the earth, the separate and equal station to which the laws of nature and of nature's God entitle them, a decent respect to the opinions of mankind requires that they should declare *the causes which impel them to the separation. We hold*

Lower case a to z, 13 ems

ABCDEFGHIJKLMNOPQRSTUVWXYZ
1234567890

10 POINT FRENCH OLD STYLE NO 2 ^F

WHEN, in the course of human events, it becomes necessary for one people to dissolve the political bands which have connected them with another, and to assume, among the powers of the earth, the separate and equal station to which the laws of nature and of nature's God entitle them, a decent respect to the opinions of mankind requires that they should *declare the causes which impel them to the separation. We hold*

Lower case a to z, 12¾ ems

ABCDEFGHIJKLMNOPQRSTUVWXYZ
1234567890

10 POINT OLD STYLE NO 72 ^{C-E}

WHEN, in the course of human events, it becomes necessary for one people to dissolve the political bands which have connected them with another, and to assume, among the powers of the earth, the separate and equal station to which the laws of nature and of nature's God entitle them, a decent respect to the opinions of mankind requires that they should *declare the causes which impel them to the separation. We hold*

Lower case a to z, 13 ems

ABCDEFGHIJKLMNOPQRSTUVWXYZ
1234567890

10 POINT SELF SPACING OLD STYLE No 29 ^B

Unit of measure, 9 to Pica

WHEN, in the course of human events, it becomes necessary for one people to dissolve the political bands which have connected them with another, and to assume, among the powers of the earth, the separate and equal station to which the laws of nature and of nature's God entitle them, a decent respect to the opinions of mankind requires that they should *declare the causes which impel them to the separation.* We

Lower case a to z, 12 $\frac{3}{8}$ ems

ABCDEFGHIJKLMN OPQRSTUVWXYZ
1234567890

10 POINT OLD STYLE No 83 ^E

WHEN, in the course of human events, it becomes necessary for one people to dissolve the political bands which have connected them with another, and to assume, among the powers of the earth, the separate and equal station to which the laws of nature and of nature's God entitle them, a decent respect to the opinions of mankind requires that *they should declare the causes which impel them to the separa-*

Lower case a to z, 13 $\frac{1}{2}$ ems

ABCDEFGHIJKLMN OPQRSTUVWXYZ
1234567890

10 POINT OLD STYLE No 325 ^B

WHEN, in the course of human events, it becomes necessary for one people to dissolve the political bands which have connected them with another, and to assume, among the powers of the earth, the separate and equal station to which the laws of nature and of nature's God entitle them, a decent respect to the opinions of mankind requires that *they should declare the causes which impel them*

Lower case a to z, 13 1-5 ems

ABCDEFGHIJKLMN OPQRSTUVWXYZ
1234567890

10 POINT CUSHING MONOTONE No 2 ^F

When, in the course of human events, it becomes necessary for one people to dissolve the political bands which have connected them with another, and to assume, among the powers of the earth, the separate and equal station to which the laws of nature and of nature's God entitle them, a decent respect to the opinions of mankind requires that they should declare the causes which impel

Lower case a to z, 13 $\frac{5}{8}$ ems

ABCDEFGHIJKLMN OPQRSTUVWXYZ
1234567890

10 POINT SELF SPACING OLD STYLE NO 24 8

Unit of measure, 8 to Pica

WHEN, in the course of human events, it becomes necessary for one people to dissolve the political bands which have connected them with another, and to assume, among the powers of the earth, the separate and equal station to which the laws of nature and of nature's God entitle them, a decent respect to the opinions of *mankind requires that they should declare the causes*

Lower case a to z, 14 ems

ABCDEFGHIJKLMNOPQRSTUVWXYZ
1234567890

10 POINT CAXTON OLD STYLE E

WHEN, in the course of human events, it becomes necessary for one people to dissolve the political bands which have connected them with another, and to assume, among the powers of the earth, the separate and equal station to which the laws of nature and of nature's God entitle them, a decent *respect to the opinions of mankind requires that*

Lower case a to z, 15½ ems

ABCDEFGHIJKLMNOPQRSTUVWXYZ
1234567890

11 POINT OLD STYLE NO 71 0

WHEN, in the course of human events, it becomes necessary for one people to dissolve the political bands which have connected them with another, and to assume, among the powers of the earth, the separate and equal station to which the laws of nature and of nature's God entitle them, a decent respect *to the opinions of mankind requires that they should declare the*

Lower case a to z, 11½ ems

ABCDEFGHIJKLMNOPQRSTUVWXYZ
1234567890

11 POINT OLD STYLE NO 79 A

WHEN, in the course of human events, it becomes necessary for one people to dissolve the political bands which have connected them with another, and to assume, among the powers of the earth, the separate and equal station to which the laws of nature and of nature's God entitle them, *a decent respect to the opinions of mankind requires that*

Lower case a to z, 11¾ ems

ABCDEFGHIJKLMNOPQRSTUVWXYZ
1234567890

11 POINT CUSHING MONOTONE F

When, in the course of human events, it becomes necessary for one people to dissolve the political bands which have connected them with another, and to assume, among the powers of the earth, the separate and equal station to which the laws of nature and of nature's God entitle them, a decent respect to the opinions of mankind requires that they should declare the causes which impel them to the separation. We hold these truths to be self-evident, that all men are created equal; that they are endowed by their Creator with certain unalienable rights; that among these,

Lower case a to z, 11 $\frac{1}{8}$ ems

ABCDEFGHIJKLMNOPQRSTUVWXYZ

1234567890

11 POINT OLD STYLE NO 84 E

WHEN, in the course of human events, it becomes necessary for one people to dissolve the political bands which have connected them with another, and to assume, among the powers of the earth, the separate and equal station to which the laws of nature and of nature's God entitle them, a decent respect to the opinions of mankind requires that they should declare the causes which impel them to the separation. We hold these truths to be self-evident, that all men are created equal; that they are endowed by their *Creator with certain unalienable rights; that among these,*

Lower case a to z, 12 $\frac{1}{2}$ ems

ABCDEFGHIJKLMNOPQRSTUVWXYZ

1234567890

11 POINT OLD STYLE NO 72 C-E

WHEN, in the course of human events, it becomes necessary for one people to dissolve the political bands which have connected them with another, and to assume, among the powers of the earth, the separate and equal station to which the laws of nature and of nature's God entitle them, a decent respect to the opinions of mankind requires that they should declare the causes which impel them to the separation. We hold these truths to be self-evident, that all men are created equal; that they are *endowed by their Creator with certain unalienable rights*

Lower case a to z, 12 $\frac{1}{2}$ ems

ABCDEFGHIJKLMNOPQRSTUVWXYZ

1234567890

11 POINT OLD STYLE NO 77 ^c

WHEN, in the course of human events, it becomes necessary for one people to dissolve the political bands which have connected them with another, and to assume, among the powers of the earth, the separate and equal station to which the laws of nature and of nature's God entitle them, a decent respect to the opinions of mankind requires that they should declare the causes which impel them to the separation. We hold these truths to be self-evident, that all men are created equal; that *they are endowed by their Creator with certain unalien-*

Lower case a to z, 12 4-5 ems

ABCDEFGHIJKLMN O PQRSTU VWXYZ

1234567890

11 POINT SELF SPACING OLD STYLE NO 25 ^b

Unit of measure, 8 to Pica

WHEN, in the course of human events, it becomes necessary for one people to dissolve the political bands which have connected them with another, and to assume, among the powers of the earth, the separate and equal station to which the laws of nature and of nature's God entitle them, a decent respect to the opinions of mankind requires that they should declare the causes which impel them to the separation. We hold these truths to be self-evident, that all men are created equal; *that they are endowed by their Creator with certain*

Lower case a to z, 12 $\frac{2}{3}$ ems

ABCDEFGHIJKLMN O PQRSTU VWXYZ

1234567890

11 POINT OLD STYLE NO 325 ^b

WHEN, in the course of human events, it becomes necessary for one people to dissolve the political bands which have connected them with another, and to assume, among the powers of the earth, the separate and equal station to which the laws of nature and of nature's God entitle them, a decent respect to the opinions of mankind requires that they should declare the causes which impel them to the separation. We hold these truths to be self-evident, that *all men are created equal; that they are endowed by their*

Lower case a to z, 13 1-5 ems

ABCDEFGHIJKLMN O PQRSTU VWXYZ

1234567890

11 POINT OLD STYLE NO 83 ^E

WHEN, in the course of human events, it becomes necessary for one people to dissolve the political bands which have connected them with another, and to assume, among the powers of the earth, the separate and equal station to which the laws of nature and of nature's God entitle them, a decent respect to the opinions of mankind requires that they should declare the causes which impel them to the separation. We hold these truths to be self-evident, that all men are created equal; that they are

Lower case a to z, 13¾ ems

ABCDEFGHIJKLMNOPQRSTUVWXYZ

1234567890

12 POINT CUSHING ^A

WHEN, in the course of human events, it becomes necessary for one people to dissolve the political bands which have connected them with another, and to assume, among the powers of the earth, the separate and equal station to which the laws of nature and of nature's God entitle them, a decent respect to the opinions of mankind requires that they should declare the causes which impel them to the separation. We hold these truths to be self-evident, that all men are

Lower case a to z, 12 ems

ABCDEFGHIJKLMNOPQRSTUVWXYZ

1234567890

12 POINT OLD STYLE NO 71 ^C

WHEN, in the course of human events, it becomes necessary for one people to dissolve the political bands which have connected them with another, and to assume, among the powers of the earth, the separate and equal station to which the laws of nature and of nature's God entitle them, a decent respect to the opinions of mankind requires that they should declare the causes which impel them to the separation. We hold these truths to be self-evident, that all

Lower case a to z, 11 5-6 ems

ABCDEFGHIJKLMNOPQRSTUVWXYZ

1234567890

12 POINT FRENCH ELZEVIR NO 1 ^A

WHEN, in the course of human events, it becomes necessary for one people to dissolve the political bands which have connected them with another, and to assume, among the powers of the earth, the separate and equal station to which the laws of nature and of nature's God entitle them, a decent respect to the opinions of mankind requires that they should declare the causes which impel them to the separation. *We hold these truths to be self-evident, that all men are*

Lower case a to z, 12½ ems

ABCDEFGHIJKLMNOPQRSTUVWXYZ
1234567890

12 POINT OLD STYLE NO 84 ^E

WHEN, in the course of human events, it becomes necessary for one people to dissolve the political bands which have connected them with another, and to assume, among the powers of the earth, the separate and equal station to which the laws of nature and of nature's God entitle them, a decent respect to the opinions of mankind requires that they should declare the causes which impel them to the separation. *We hold these truths to be self-evident, that all*

Lower case a to z, 12½ ems

ABCDEFGHIJKLMNOPQRSTUVWXYZ
1234567890

12 POINT OLD STYLE NO 79 ^A

WHEN, in the course of human events, it becomes necessary for one people to dissolve the political bands which have connected them with another, and to assume, among the powers of the earth, the separate and equal station to which the laws of nature and of nature's God entitle them, a decent respect to the opinions of mankind requires that they should declare the causes which impel them to the separation. *We hold these truths to be self-evident,*

Lower case a to z, 12 2-5 ems

ABCDEFGHIJKLMNOPQRSTUVWXYZ
1234567890

12 POINT OLD STYLE NO 72 C E

WHEN, in the course of human events, it becomes necessary for one people to dissolve the political bands which have connected them with another, and to assume, among the powers of the earth, the separate and equal station to which the laws of nature and of nature's God entitle them, a decent respect to the opinions of mankind requires that they should declare the causes which impel them *to the separation. We hold these truths to be self-*

Lower case a to z, 12½ emsABCDEFGHIJKLMN**OP**QRSTUVWXYZ

1234567890

12 POINT OLD STYLE NO 77 C

WHEN, in the course of human events, it becomes necessary for one people to dissolve the political bands which have connected them with another, and to assume, among the powers of the earth, the separate and equal station to which the laws of nature and of nature's God entitle them, a decent respect to the opinions of mankind requires that they should declare the causes which impel them *to the separation. We hold these truths to be self-*

Lower case a to z, 12½ emsABCDEFGHIJKLMN**OP**QRSTUVWXYZ

1234567890

12 POINT FRENCH OLD STYLE NO 2 F

WHEN, in the course of human events, it becomes necessary for one people to dissolve the political bands which have connected them with another, and to assume, among the powers of the earth, the separate and equal station to which the laws of nature and of nature's God entitle them, a decent respect to the opinions of mankind requires that they should declare the causes which impel them *to the separation. We hold these truths to be*

Lower case a to z, 13 emsABCDEFGHIJKLMN**OP**QRSTUVWXYZ

1234567890

12 POINT SELF SPACING OLD STYLE NO 26 ⁸

Unit of measure, 7 to Pica

WHEN, in the course of human events, it becomes necessary for one people to dissolve the political bands which have connected them with another, and to assume, among the powers of the earth, the separate and equal station to which the laws of nature and of nature's God entitle them, a decent respect to the opinions of mankind requires that they should declare the causes which *impel them to the separation.* We hold these

Lower case a to z, 13¼ ems

ABCDEFGHIJKLMNOPQRSTUVWXYZ
1234567890

12 POINT OLD STYLE NO 83 ⁸

WHEN, in the course of human events, it becomes necessary for one people to dissolve the political bands which have connected them with another, and to assume, among the powers of the earth, the separate and equal station to which the laws of nature and of nature's God entitle them, a decent respect to the opinions of mankind requires that they should *declare the causes which impel them to the*

Lower case a to z, 14 ems

ABCDEFGHIJKLMNOPQRSTUVWXYZ
1234567890

12 POINT OLD STYLE NO 325 ⁸

WHEN, in the course of human events, it becomes necessary for one people to dissolve the political bands which have connected them with another, and to assume, among the powers of the earth, the separate and equal station to which the laws of nature and of nature's God entitle them, a decent respect to the opinions of mankind requires *that they should declare the causes which im-*

Lower case a to z, 14½ ems

ABCDEFGHIJKLMNOPQRSTUVWXYZ
1234567890

12 POINT CAXTON OLD STYLE ^ε

WHEN, in the course of human events, it becomes necessary for one people to dissolve the political bands which have connected them with another, and to assume, among the powers of the earth, the separate and equal station to which the laws of nature and of nature's God entitle them, a decent respect to the opinions of mankind requires that they should declare the causes which impel them to the separation. We hold these truths to be self-evident, that all men are created equal; that they are endowed by their Creator with unalienable rights; that among these, are life, liberty, and the pursuit of happiness. That, *to secure these rights, governments are*

Lower case a to z, 14½ ems

ABCDEFGHIJKLMNOPQRSTUVWXYZ
1234567890

14 POINT OLD STYLE NO 71 ^ο

WHEN, in the course of human events, it becomes necessary for one people to dissolve the political bands which have connected them with another, and to assume, among the powers of the earth, the separate and equal station to which the laws of nature and of nature's God entitle them, a decent respect to the opinions of mankind requires that they should declare the causes which impel them to the separation. We hold these truths to be self-evident, that all men are created equal; that they are endowed by their Creator with certain unalienable rights; *that among these, are life, liberty, and the pursuit*

ABCDEFGHIJKLMNOPQRSTUVWXYZ
1234567890

14 POINT OLD STYLE NO 79 ^A

WHEN, in the course of human events, it becomes necessary for one people to dissolve the political bands which have connected them with another, and to assume, among the powers of the earth, the separate and equal station to which the laws of nature and of nature's God entitle them, a decent respect to the opinions of mankind requires that they should declare the causes which impel them to the separation. We hold these truths to be self-evident, that all men are created equal; that they are endowed by their Creator with certain *unalienable rights; that among these, are life*

ABCDEFGHIJKLMNOPQRSTUVWXYZ

1234567890

14 POINT FRENCH ELZEVIR NO 1 ^{*}

When, in the course of human events, it becomes necessary for one people to dissolve the political bands which have connected them with another, and to assume, among the powers of the earth, the separate and equal station to which the laws of nature and of nature's God entitle them, a decent respect to the opinions of mankind requires that they should declare the causes which impel them to the separation. We hold these truths to be self-evident, that all men are created equal; that they are endowed by their Creator with certain *unalienable rights; that among these, are*

ABCDEFGHIJKLMNOPQRSTUVWXYZ

1234567890

15 POINT OLD STYLE NO 72 °

12 A 6 A 40 a \$4 55

WHEN, in the course of human events, it becomes necessary for one people to dissolve the political bands which have connected them with another, and to assume, among the powers of the earth, the separate and equal station to which the laws of nature and of nature's God entitle them, a decent respect to the opinions of mankind requires that they should state the causes which impel them to the separation. We hold these truths to be self-evident, that all men are created equal; that they are

ABCDEFGHIJKLMNOPQRSTUVWXYZ

1234567890

15 POINT CUSHING °

15 A 25 a \$3 50

When, in the course of human events, it becomes necessary for one people to dissolve the political bands which have connected them with another, and to assume, among the powers of the earth, the separate and equal station to which the laws of nature and of nature's God entitle them, a decent respect to the opinions of mankind requires that they *should declare the causes which impel them*

Lower case a to z, 13 5-6 ems

ABCDEFGHIJKLMNOPQRSTUVWXYZ

1234567890

OLD STYLE ROMANS SHOWN BY SERIES

RONALDSON SERIES No 72

6 POINT OLD STYLE NO 72

WHEN, in the course of human events, it becomes necessary for one people to dissolve the political bands which have connected them with another, and to assume, among the powers of the earth, the separate and equal station to which the laws of nature and of nature's God entitle them, a decent respect to the opinions of mankind requires that they should declare the causes which impel them to the separation. We hold these truths to be self-evident, that all men are created equal; that they are endowed by their Creator with certain unalienable rights; that among these, are life, liberty, and the *pursuit of happiness*. That, to secure these rights, governments are instituted among men, deriving their just powers from the consent of the governed; that, whenever any form of government becomes destructive of these ends, it is the right of the people to alter or to abolish it, and to institute a new government, laying its foundation on such principles, and organizing its powers in such form, as to them shall seem most likely to effect their safety and happiness. Prudence, indeed, will dictate that governments long established, should not be changed for light and transient causes; and, accordingly, all experience hath shown, that mankind are more disposed to suffer, while evils are sufferable, than

Lower case a to z, 15½ ems

ABCDEFGHIJKLMNOPQRSTUVWXYZ

1234567890

7 POINT OLD STYLE NO 72

WHEN, in the course of human events, it becomes necessary for one people to dissolve the political bands which have connected them with another, and to assume, among the powers of the earth, the separate and equal station to which the laws of nature and of nature's God entitle them, a decent respect to the opinions of mankind requires that they should declare the causes which impel them to the separation. We hold these truths to be self-evident, that all men are created equal; that they are endowed by their Creator with *certain unalienable rights*; that among these, are life, liberty, and the pursuit of happiness. That, to secure these rights, governments are instituted among men, deriving their just powers from the consent of the governed; that, whenever any form of government becomes destructive of these ends, it is the right of the people to alter or to abolish it, and to institute a new government, laying its foundation on such principles, and

Lower case a to z, 14¾ ems

ABCDEFGHIJKLMNOPQRSTUVWXYZ

1234567890

8 POINT OLD STYLE NO 72

WHEN, in the course of human events, it becomes necessary for one people to dissolve the political bands which have connected them with another, and to assume, among the powers of the earth, the separate and equal station to which the laws of nature and of nature's God entitle them, a decent respect to the opinions of mankind requires that they should declare the causes which impel them to the separation. *We hold these truths to be self-evident, that* all men are created equal; that they are endowed by their Creator with certain unalienable rights; that among these, are life, liberty, and the pursuit of happiness. That, to secure these rights, governments are instituted among men, deriving their just powers from the consent of the governed; that, whenever any form of government becomes destructive of these ends, it is the right

Lower case a to z, 14 ems

ABCDEFGHIJKLMNOPQRSTUVWXYZ

1234567890

Old Style Figures only included in regular fonts. Modern Figures furnished if desired

9 POINT OLD STYLE NO 72

WHEN, in the course of human events, it becomes necessary for one people to dissolve the political bands which have connected them with another, and to assume, among the powers of the earth, the separate and equal station to which the laws of nature and of nature's God entitle them, a decent respect to the opinions of mankind requires that they should declare the causes which impel them to the separation. *We hold these truths to be self-evident,* that all men are created equal; that they are endowed by their Creator with certain unalienable rights; that among these, are life, liberty, and the pursuit of happiness. That, to secure these rights, governments are instituted among men, deriving their just powers from the consent of the governed; that, whenever any

Lower case a to z, 13½ ems

ABCDEFGHIJKLMNOPQRSTUVWXYZ

1234567890

10 POINT OLD STYLE NO 72

WHEN, in the course of human events, it becomes necessary for one people to dissolve the political bands which have connected them with another, and to assume, among the powers of the earth, the separate and equal station to which the laws of nature and of nature's God entitle them, a decent respect *to the opinions of mankind* requires that they should declare the causes which impel them to the separation. We hold these truths to be self-evident, that all men are created equal; that they are endowed by their Creator with certain unalienable rights; that among these, are life, liberty, and the pursuit

Lower case a to z, 13 ems

ABCDEFGHIJKLMNOPQRSTUVWXYZ

1234567890

11 POINT OLD STYLE NO 72

WHEN, in the course of human events, it becomes necessary for one people to dissolve the political bands which have connected them with another, and to assume, among the powers of the earth, the separate and equal station to which *the laws of nature and of nature's God* entitle them, a decent respect to the opinions of mankind requires that they should declare the causes which impel them to the separation. We hold these truths to be self-evident, that all men are created equal; that they are endowed by their

Lower case a to z, 12½ ems

ABCDEFGHIJKLMNOPQRSTUVWXYZ

1234567890

Old Style Figures only included in regular fonts. Modern Figures furnished if desired

12 POINT OLD STYLE NO 72

WHEN, in the course of human events, it becomes necessary for one people to dissolve the political bands which have connected them with another, and to assume, among the powers of the earth, the separate and equal station to which the laws of nature and of nature's God entitle them, a decent respect to the opinions of mankind requires that they should declare the causes which impel them to the separation. *We hold these truths to be self-evident*, that all men are created equal; that they are endowed by their Creator with certain unalienable rights; that among these, are life, liberty, and the pursuit of happiness. That, to secure these rights, governments are instituted among men, deriving their just

Lower case a to z, 12½ ems

ABCDEFGHIJKLMN OPQRSTUVWXYZ

1234567890

15 POINT OLD STYLE NO 72

12 A 6 A 40 a \$4 55

WHEN, in the course of human events, it becomes necessary for one people to dissolve the political bands which have connected them with another, and to assume, among the powers of the earth, the separate and equal station to which the laws of nature and of nature's God entitle them, a decent respect to the opinions of mankind requires that they should declare the causes which impel them to the separation. We hold these truths to be self-evident, that all men are created equal; that they are en-

ABCDEFGHIJKLMN OPQRSTUVWXYZ

1234567890

Old Style Figures only included in regular fonts. Modern Figures furnished if desired

Larger sizes of this series are shown on pages 489 and 490

CASLON OLD STYLE NO 71

Old English characters, as under, furnished for all sizes when specially ordered as additions to regular fonts

æ f ſ ſb ſh ſi ſſ ſk ſl ſt

This face was cut in 1722, and is the oldest type face now in use in the United States. It has survived on account of very exceptional merit, and is more popular to-day than at any period since the introduction of the Modern Roman face.

6 POINT OLD STYLE NO 71

WHEN, in the course of human events, it becomes necessary for one people to dissolve the political bands which have connected them with another, and to assume, among the powers of the earth, the separate and equal station to which the laws of nature and of nature's God entitle them, a decent respect to the opinions of mankind requires that they should declare the causes which impel them to the separation. *We hold these truths to be self-evident*, that all men are created equal; that they are endowed by their Creator with certain unalienable rights; that among these, are life, liberty, and the pursuit of happiness. That, to secure these rights, governments are instituted among men, deriving their just powers from the consent of the

Lower case a to z, 13½ ems

ABCDEFGHIJKLMN OPQRSTUVWXYZ
1234567890

8 POINT OLD STYLE NO 71

WHEN, in the course of human events, it becomes necessary for one people to dissolve the political bands which have connected them with another, and to assume, among the powers of the earth, the separate and equal station to which the laws of nature and of nature's God entitle them, a decent respect to the opinions of mankind requires that they should declare the causes which impel them to the separation. *We hold these truths to be self-evident*, that all men are created equal; that they

Lower case a to z, 11½ ems

ABCDEFGHIJKLMN OPQRSTUVWXYZ
1234567890

9 POINT OLD STYLE NO 71

WHEN, in the course of human events, it becomes necessary for one people to dissolve the political bands which have connected them with another, and to assume, among the powers of the earth, the separate and equal station to which the laws of nature and of nature's God entitle them, a decent respect to the opinions of mankind requires that they should declare the causes which impel them to the separation. *We hold these truths to be self-evident*, that all men are created equal; that they are endowed by their Creator with certain unalienable rights; that among these, are life, liberty, and the pursuit of happiness. That, to secure these rights, governments are instituted among men, deriving their just powers from the consent of the

Lower case a to z, 11 2-5 ems

ABCDEFGHIJKLMN OPQRSTUVWXYZ
1234567890

10 POINT OLD STYLE NO 71

WHEN, in the course of human events, it becomes necessary for one people to dissolve the political bands which have connected them with another, and to assume, among the powers of the earth, the separate and equal station to which the laws of nature and of nature's God entitle them, *a decent respect to the opinions of mankind* requires that they should declare the causes which impel them to the separation. *We hold these truths to be self-evident*, that all men are created equal; that they are endowed by their Creator with certain unalienable rights;

Lower case a to z, 11¼ ems

ABCDEFGHIJKLMN OPQRSTUVWXYZ
1234567890

11 POINT OLD STYLE NO 71

WHEN, in the course of human events, it becomes necessary for one people to dissolve the political bands which have connected them with another, and to assume, among the powers of the earth, the separate and equal station to which the laws of nature and of nature's God entitle them, a decent respect to *the opinions of mankind requires that they* should declare the causes which impel them to the separation. We hold these truths to be self-evident, that all men are created equal; that they are endowed by their Creator with certain unalienable rights; that

Lower case a to z, 11½ ems

ABCDEFGHIJKLMNOPQRSTUVWXYZ

1234567890

12 POINT OLD STYLE NO 71

WHEN, in the course of human events, it becomes necessary for one people to dissolve the political bands which have connected them with another, and to assume, among the powers of the earth, the separate and equal station to which *the laws of nature and of nature's God* entitle them, a decent respect to the opinions of mankind requires that they should declare the causes which impel them to the separation. We hold these truths to be self-evident, that all men are created equal; that

Lower case a to z, 11 5-6 ems

ABCDEFGHIJKLMNOPQRSTUVWXYZ

1234567890

14 POINT OLD STYLE NO 71

WHEN, in the course of human events, it becomes necessary for one people to dissolve the political bands which have connected them with another, and to assume, *among the powers of the earth*, the separate and equal station to which the laws of nature and of nature's God entitle them, a decent respect to the opinions of mankind requires that

ABCDEFGHIJKLMNOPQRSTUVWXYZ

1234567890

BINNY SERIES NO 77

6 POINT OLD STYLE NO 77

WHEN, in the course of human events, it becomes necessary for one people to dissolve the political bands which have connected them with another, and to assume, among the powers of the earth, the separate and equal station to which the laws of nature and of nature's God entitle them, a decent respect to the opinions of mankind requires that they should declare the causes which impel them to the separation. We hold these truths to be self-evident, *that all men are created equal*; that they are endowed by their Creator with certain unalienable rights; that among these, are life, liberty, and the pursuit of happiness. That, to secure these rights, governments are instituted among men, deriving their just powers from the consent of the governed; that, whenever any form of government becomes destructive of these ends, it is the right of the people to alter or to abolish it, and to institute a new government, laying its foundation on such principles

Lower case a to z, 15¼ ems

ABCDEFGHIJKLMNOPQRSTUVWXYZ

1234567890

7 POINT OLD STYLE NO 77

WHEN, in the course of human events, it becomes necessary for one people to dissolve the political bands which have connected them with another, and to assume, among the powers of the earth, the separate and equal station to which the laws of nature and of nature's God entitle them, a decent respect to the opinions of mankind requires *that they should declare the causes* which impel them to the separation. We hold these truths to be self-evident, that all men are created equal; that they are endowed by their Creator with certain unalienable rights; that among these, are life, liberty, and the pursuit of happiness. That, to secure these rights, governments are instituted

Lower case a to z, 14 4-5 ems

ABCDEFGHIJKLMNOPQRSTUVWXYZ

1234567890

8 POINT OLD STYLE NO 77

WHEN, in the course of human events, it becomes necessary for one people to dissolve the political bands which have connected them with another, and to assume, among the powers of the earth, the separate and equal station to which the laws of nature and of nature's God entitle them, *a decent respect to the opinions of mankind requires* that they should declare the causes which impel them to the separation. We hold these truths to be self-evident, that all men are created equal; that they are endowed by their Creator with certain unalienable rights; that

Lower case a to z, 13¾ ems

ABCDEFGHIJKLMNOPQRSTUVWXYZ

1234567890

9 POINT OLD STYLE NO 77

WHEN, in the course of human events, it becomes necessary for one people to dissolve the political bands which have connected them with another, and to assume, among the powers of the earth, the *separate and equal station* to which the laws of nature and of nature's God entitle them, a decent respect to the opinions of mankind requires that they should declare the causes which impel them to the separation. We hold these truths to be self-evident, that all men

Lower case a to z, 13 ems

ABCDEFGHIJKLMNOPQRSTUVWXYZ

1234567890

10 POINT OLD STYLE NO 77

WHEN, in the course of human events, it becomes necessary for one people to dissolve the political bands which have connected them with another, and to assume, among the powers of the earth, the separate and equal station to which the laws of nature and of nature's God entitle them, a decent respect to the opinions of mankind *requires that they should declare* the causes which impel them to the separation. We hold these truths to be self-evident, that all men are created equal; that they are endowed by their Creator with certain unalienable rights; that among these, are life, liberty, and the pursuit of happiness. That, whenever any form of government becomes destructive

Lower case a to z, 12 ems

ABCDEFGHIJKLMNOPQRSTUVWXYZ
1234567890

11 POINT OLD STYLE NO 77

WHEN, in the course of human events, it becomes necessary for one people to dissolve the political bands which have connected them with another, and to assume, among the powers of the earth, the separate and equal station to which the laws of nature and of nature's God entitle them, a decent respect *to the opinions of mankind* requires that they should declare the causes which impel them to the separation. We hold these truths to be self-evident, that all men are created equal; that they are endowed by their Creator with certain unalienable rights

Lower case a to z, 12 4-5 ems

ABCDEFGHIJKLMNOPQRSTUVWXYZ
1234567890

12 POINT OLD STYLE NO 77

WHEN, in the course of human events, it becomes necessary for one people to dissolve the political bands which have connected them with another, and to assume, among the powers of the earth, the separate and equal station to *which the laws of nature and* of nature's God entitle them, a decent respect to the opinions of mankind requires that they should declare the causes which impel them to the separation. We hold these truths to be self-evident, that all men

Lower case a to z, 12½ ems

ABCDEFGHIJKLMNOPQRSTUVWXYZ
1234567890

FRANKLIN SERIES No 79

5 POINT OLD STYLE NO 79

WHEN, in the course of human events, it becomes necessary for one people to dissolve the political bands which have connected them with another, and to assume, among the powers of the earth, the separate and equal station to which the laws of nature and of nature's God entitle them, a decent respect to the opinions of mankind requires that they should declare the causes which impel them to the separation. We hold these truths to be self-evident, that all men are created equal; that they are endowed by their Creator with certain unalienable rights; that among these, are life, liberty, and the pursuit of happiness. That, to secure these rights, governments are instituted among men, deriving their just powers from the consent of the governed; that, whenever any form of government becomes destructive of these ends, it is the right of the people to alter or to abolish it, and to institute a new government, laying its foundation on such principles, and organizing its powers in such form, as to them shall seem most likely to effect their safety and happiness. Prudence, indeed, will dictate that governments long established should not be changed for light and transient causes; and, accordingly, all experience hath shown, that mankind are more disposed to suffer, while evils are sufferable, than to right themselves by abolishing the forms to

Lower case a to z, 14¼ ems

ABCDEFGHIJKLMNOPQRSTUVWXYZ

1234567890

6 POINT OLD STYLE NO 79

WHEN, in the course of human events, it becomes necessary for one people to dissolve the political bands which have connected them with another, and to assume, among the powers of the earth the separate and equal station to which the laws of nature and of nature's God entitle them, a decent respect to the opinions of mankind requires that they should declare the causes which impel them to the separation. We hold these truths to be self-evident, that all men are created equal; that they are endowed by their Creator with certain unalienable rights; that among these, are life, liberty, and the pursuit of happiness. That, to secure these rights, governments are instituted among men, deriving their just powers from the consent of the governed; that, whenever any form of government becomes destructive of these ends, it is the right of the people to alter or to abolish it, and to institute a new government, laying its foundation on such principles, and organizing its powers in such form, as to them

Lower case a to z, 13⅔ ems

ABCDEFGHIJKLMNOPQRSTUVWXYZ

1234567890

7 POINT OLD STYLE NO 79

WHEN, in the course of human events, it becomes necessary for one people to dissolve the political bands which have connected them with another, and to assume, among the powers of the earth, the separate and equal station to which the laws of nature and of nature's God entitle them, a decent respect to the opinions of mankind requires that they should declare the causes which impel them to the separation. We hold these truths to be self-evident, that all men are created equal; that they are endowed by their Creator with certain unalienable rights; that among these, are life, liberty, and the pursuit of happiness. That, to secure these rights, governments are instituted among men, deriving their just powers from the consent of the governed; that, whenever any form of government becomes destructive of these ends, it is the right of the people to alter or to abolish it, and to institute a new government, laying

Lower case a to z, 13 ems

ABCDEFGHIJKLMNOPQRSTUVWXYZ

1234567890

8 POINT OLD STYLE NO 79

WHEN, in the course of human events, it becomes necessary for one people to dissolve the political bands which have connected them with another, and to assume, among the powers of the earth, the separate and equal station to which the laws of nature and of nature's God entitle them, a decent respect to the opinions of mankind requires that they should declare the causes which impel them to the separation. We hold these truths to be self-evident, that all men are created equal; that they are endowed by their Creator, with certain unalienable rights; that among these, are life, liberty, and the pursuit of happiness. That, to secure these rights, governments are instituted among men, deriving their just powers from the consent of the

Lower case a to z, 12⅔ ems

ABCDEFGHIJKLMNOPQRSTUVWXYZ

1234567890

9 POINT OLD STYLE NO 79 ^A

WHEN, in the course of human events, it becomes necessary for one people to dissolve the political bands which have connected them with another, and to assume, among the powers of the earth, the separate and equal station to which the laws of nature and of nature's God entitle them, a decent respect to the opinions of mankind requires that they should declare the causes which impel them to the separation. We hold these truths to be self-evident, that all men are created equal: that they are endowed by their Creator with certain unalienable rights; that among these, are life, liberty, and the pursuit of happiness. That, to secure these rights, governments are instituted among men, deriving their just powers from the consent of the governed; that, whenever any form of government becomes de-

Lower case a to z, 12½ ems

ABCDEFGHIJKLMNOPQRSTUVWXYZ

1234567890

10 POINT OLD STYLE NO 79 ^A

WHEN, in the course of human events, it becomes necessary for one people to dissolve the political bands which have connected them with another, and to assume, among the powers of the earth, the separate and equal station to which the laws of nature and of nature's God entitle them, a decent respect to the opinions of mankind requires that they should declare the causes which impel them to the separation. We hold these truths to be self-evident, that all men are created equal; that they are endowed by their Creator with certain unalienable rights; that among these, are life, liberty, and the pursuit of happiness. That, to secure these rights, governments are instituted among

Lower case a to z, 12 ems

ABCDEFGHIJKLMNOPQRSTUVWXYZ

1234567890

11 POINT OLD STYLE NO 79 ^A

WHEN, in the course of human events, it becomes necessary for one people to dissolve the political bands which have connected them with another, and to assume, among the powers of the earth, the separate and equal station to which the laws of nature and of nature's God entitle them, a decent respect to the opinions of mankind requires that they should declare the causes which impel them to the separation. We hold these truths to be self-evident, that all men are created equal; that they are endowed by their Creator

Lower case a to z, 11¾ ems

ABCDEFGHIJKLMNOPQRSTUVWXYZ

1234567890

12 POINT OLD STYLE NO 79 A

WHEN, in the course of human events, it becomes necessary for one people to dissolve the political bands which have connected them with another, and to assume, among the powers of the earth, the separate and equal station to which the laws of nature and of nature's God entitle them, a decent respect to the opinions of mankind requires that they should declare the causes which impel them to the separation. We hold these truths to be self-evident, that all men are created equal; that they are endowed by their Creator with certain unalienable rights; that among these, are life, liberty, and the pursuit of happiness. That, to secure these rights, *governments are instituted among men, deriving their just powers from the consent of the governed; that,*

Lower case a to z, 12 2-5 ems

ABCDEFGHIJKLMN OPQRSTUVWXYZ

1234567890

14 POINT OLD STYLE NO 79 A

WHEN, in the course of human events, it becomes necessary for one people to dissolve the political bands which have connected them with another, and to assume, among the powers of the earth, the separate and equal station to which the laws of nature and of nature's God entitle them, a decent respect to the opinions of mankind requires that they should declare the causes which impel them to the separation. We hold these truths to be self-evident, that all men are created equal; *that they are endowed by their Creator with certain unalienable rights; that among these,*

Lower case a to z, 12 ems

ABCDEFGHIJKLMN OPQRSTUVWXYZ

1234567890

Larger sizes shown on page 491^d

OLD STYLE ROMAN SERIES No 73

5½ POINT OLD STYLE NO 73

WHEN, in the course of human events, it becomes necessary for one people to dissolve the political bands which have connected them with another, and to assume, among the powers of the earth, the separate and equal station to which the laws of nature and of nature's God entitle them, a decent respect to the opinions of mankind requires that they should declare the causes which impel them to the separation. We hold these truths to be self-evident, that all men are created equal: that they are endowed by their Creator with certain unalienable rights; that among these, are life, liberty, and the pursuit of happiness. That, to secure these rights, governments are instituted among men, deriving their just powers from the consent of the governed; that, whenever any form of government becomes *destructive of these ends*, it is the right of the people to alter or to abolish it, and to institute a new government, laying its foundation on such principles, and organizing its powers in such form, as to them shall seem most likely to effect their safety and happiness. Prudence, indeed, will dictate that governments long established, should not be changed for light and transient causes; and, accordingly, all experience hath shown, that mankind are more disposed to suffer, while evils are sufferable, than to right themselves by abolishing the forms to which they are accustomed. But, when a long train of abuses and usurpations, pursuing invariably the same object, evinces a design to reduce them under absolute despotism, it is their right, it is their duty, to throw off such government, and to provide new guards for their future security. Such has been the patient sufferance of these colonies, and such is now the necessity

Lower case a to z, 16½ ems

ABCDEFGHIJKLMN OPQRSTUVWXYZ
1234567890

6 POINT OLD STYLE NO 73

WHEN, in the course of human events, it becomes necessary for one people to dissolve the political bands which have connected them with another, and to assume, among the powers of the earth, the separate and equal station to which the laws of nature and of nature's God entitle them, a decent respect to the opinions of mankind requires that they should declare the causes which impel them to the separation. We hold these truths to be self-evident, that all men are created equal; that they are endowed by their Creator with certain unalienable rights; that among these, are life, liberty, and the pursuit of happiness. That, to secure these rights, governments are instituted among men, deriving their just powers *from the consent of the governed*: that, whenever any form of government becomes destructive of these ends, it is the right of the people to alter or to abolish it, and to institute a new government, laying its foundation on such principles, and organizing its powers in such form, as to them shall seem most likely to effect their safety and happiness. Prudence, indeed, will dictate that governments long established should not be changed for light and transient causes; and, accordingly, all experience hath shown, that mankind are more disposed to suffer, while evils are sufferable, than to right themselves by abolishing the forms to which they are accustomed. But, when a long train of

Lower case a to z, 16½ ems

ABCDEFGHIJKLMN OPQRSTUVWXYZ
1234567890

7 POINT OLD STYLE NO 73

WHEN, in the course of human events, it becomes necessary for one people to dissolve the political bands which have connected them with another, and to assume among the powers of the earth, the separate and equal station to which the laws of nature and of nature's God entitle them, a decent respect to the opinions of mankind requires that they should declare the causes which impel them to the separation. We hold these truths to be self-evident, that all men are created equal; that they are endowed by their Creator *with certain unalienable rights*; that among these, are life, liberty, and the pursuit of happiness. That, to secure these rights, governments are instituted among men, deriving their just powers from the consent of the governed; that, whenever any form of government becomes destructive of these ends, it is the right of the people to alter or to abolish it, and to institute a new government, laying its foundation on such principles, and organizing its powers in such form, as to them shall seem most likely to effect their safety and happiness. Prudence,

Lower case a to z, 15¾ ems

ABCDEFGHIJKLMN OPQRSTUVWXYZ
1234567890

OLD STYLE ROMAN SERIES No 83

5½ POINT OLD STYLE NO 80 ^A

WHEN, in the course of human events, it becomes necessary for one people to dissolve the political bands which have connected them with another, and to assume, among the powers of the earth, the separate and equal station to which the laws of nature and of nature's God entitle them, a decent respect to the opinions of mankind requires that they should declare the causes which impel them to the separation. We hold these truths to be self-evident, that all men are created equal; that they are en-

Lower case a to z, 15 ems

ABCDEFGHIJKLMN OPQRSTUVWXYZ

1234567890

^E 6 POINT OLD STYLE NO 83

WHEN, in the course of human events, it becomes necessary for one people to dissolve the political bands which have connected them with another, and to assume, among the powers of the earth, the separate and equal station to which the laws of nature and of nature's God entitle them, a decent respect to the opinions of mankind requires that they should declare the causes which impel

Lower case a to z, 15¼ ems

ABCDEFGHIJKLMN OPQRSTUVWXYZ

1234567890

7 POINT OLD STYLE NO 83 ^E

WHEN, in the course of human events, it becomes necessary for one people to dissolve the political bands which have connected them with another, and to assume, among the powers of the earth, the separate and equal station to which the laws of nature and of nature's God entitle them, a decent respect to the opinions of mankind requires that they should declare the causes which impel them to the separation. We hold these truths to be self-evident, that all men are created equal; *that they are endowed by their Creator* with certain unalienable rights; that among these, are life, liberty, and the pursuit of

Lower case a to z, 14 ems

ABCDEFGHIJKLMN OPQRSTUVWXYZ

1234567890

8 POINT OLD STYLE NO 83 ^E

WHEN, in the course of human events, it becomes necessary for one people to dissolve the political bands which have connected them with another, and to assume, among the powers of the earth, the separate and equal station to which the laws of nature and of nature's God entitle them, a decent respect to the opinions of mankind requires that they should *declare the causes which impel* them to the separation. We hold these truths to be self-evident, that all men are created equal; that they are endowed by their Creator with cer-

Lower case a to z, 14 ems

ABCDEFGHIJKLMN OPQRSTUVWXYZ

1234567890

9 POINT OLD STYLE NO 83 ^E

WHEN, in the course of human events, it becomes necessary for one people to dissolve the political bands which have connected them with another, and to assume, among the powers of the earth, the separate *and equal* station to which the laws of nature and of nature's God entitle them, a decent respect to the opinions of mankind requires that they should declare the causes which impel them to the separation. We hold these

Lower case a to z, 13¼ ems

ABCDEFGHIJKLMN OPQRSTUVWXYZ

1234567890

Old Style Figures only included in regular fonts. Modern Figures furnished if desired

10 POINT OLD STYLE NO 83 °

WHEN, in the course of human events, it becomes necessary for one people to dissolve the political bands which have connected them with another, and to assume, among the powers of the earth, the separate and equal station to which the laws of nature and of nature's God entitle them, a decent respect to the opinions of mankind requires that they should *declare the causes which impel* them to the separation. We hold these truths to be self-evident, that all men are created equal; that they are endowed by their

Lower case a to z, 13½ ems

ABCDEFGHIJKLMNOPQRSTUVWXYZ
1234567890

11 POINT OLD STYLE NO 83 °

WHEN, in the course of human events, it becomes necessary for one people to dissolve the political bands which have connected them with another, and to assume, among the powers of the earth, the separate and equal station to which the laws of nature and of nature's God entitle them, a decent respect to the *opinions of mankind requires* that they should declare the causes which impel them to the separation. We hold these truths to be self-evident,

Lower case a to z, 13¾ ems

ABCDEFGHIJKLMNOPQRSTUVWXYZ
1234567890

12 POINT OLD STYLE NO 83 °

WHEN, in the course of human events, it becomes necessary for one people to dissolve the political bands which have connected them with another, and to assume, among the powers of the earth, the separate and equal station to which *the laws* of nature and of nature's God entitle them, a decent respect to the opinions of mankind requires that they

Lower case a to z, 14 ems

ABCDEFGHIJKLMNOPQRSTUVWXYZ
1234567890

*Old Style Figures only included in regular fonts. Modern Figures furnished if desired
Larger sizes of this series are shown on pages 491^e and 491^f*

OLD STYLE ROMAN SERIES No 84

6 POINT OLD STYLE NO 84

WHEN, in the course of human events, it becomes necessary for one people to dissolve the political bands which have connected them with another, and to assume, among the powers of the earth, the separate and equal station to which the laws of nature and of nature's God entitle them, a decent respect to the opinions of mankind requires that they should declare the causes which impel them to the separation. We hold these truths to be self-evident, that all men are created equal; that they are endowed by their Creator with certain unalienable rights; that among these, are life, liberty, and the pursuit of happiness. That, to secure these rights, governments are instituted among men, deriving their just powers from the consent of the governed; that, whenever any form of government becomes destructive of these ends, it is the right of the people to alter or to abolish it, and to institute a new government, laying its foundation on such principles, and organizing its powers in such form, as to them shall seem most likely to effect their safety and happiness. Prudence, indeed, will dictate that governments long established, should not be changed for light and transient causes; and, accordingly, all experience hath shown, that mankind are more disposed to suffer, while evils are sufferable, than to right themselves by abolishing the forms to which they are accustomed. But, when a long train of abuses and usurpations, pursuing invariably the same object, evinces a design to reduce them under absolute despotism, it is their right,

Lower case a to z, 15 ems

ABCDEFGHIJKLMN OPQRSTUVWXYZ

1234567890

7 POINT OLD STYLE NO 84

WHEN, in the course of human events, it becomes necessary for one people to dissolve the political bands which have connected them with another, and to assume, among the powers of the earth, the separate and equal station to which the laws of nature and of nature's God entitle them, a decent respect to the opinions of mankind requires that they should declare the causes which impel them to the separation. We hold these truths to be self-evident, that all men are created equal; that they are endowed by their Creator with certain unalienable rights; that among these, are *life, liberty, and the pursuit of happiness*. That, to secure these rights, governments are instituted among men, deriving their just powers from the consent of the governed; that, whenever any form of government becomes destructive of these ends, it is the right of the people to alter or to abolish it, and to institute a new government, laying its foundation on such principles, and organizing its powers in such form, as to them shall seem most likely to effect their safety and happiness. Prudence, indeed, will dictate that

Lower case a to z, 14¼ ems

ABCDEFGHIJKLMN OPQRSTUVWXYZ

1234567890

8 POINT OLD STYLE NO 84

WHEN, in the course of human events, it becomes necessary for one people to dissolve the political bands which have connected them with another, and to assume, among the powers of the earth, the separate and equal station to which the laws of nature and of nature's God entitle them, a decent respect to the opinions of mankind requires that they should declare the causes which impel them to the separation. We hold these truths to be self-evident, that all men are created equal; that *they are endowed by their Creator with certain unalienable rights*; that among these, are life, liberty, and the pursuit of happiness. That, to secure these rights, governments are instituted among men, deriving their just powers from the consent of the governed; that, whenever any form of government becomes destructive of these ends, it is the right of the people to alter or to abolish it, and to institute a new gov-

Lower case a to z, 14 ems

ABCDEFGHIJKLMN OPQRSTUVWXYZ

1234567890

Old Style Figures only included in regular fonts. Modern Figures furnished if desired

10 POINT OLD STYLE NO 84

WHEN, in the course of human events, it becomes necessary for one people to dissolve the political bands which have connected them with another, and to assume, among the powers of the earth, the separate and equal station to which the laws of nature and of nature's God entitle them, a decent respect to the opinions of mankind requires that they should declare the causes *which impel them to the separation*. We hold these truths to be self-evident, that all men are created equal; that they are endowed by their Creator with certain unalienable rights; that among these, are life, liberty, and the pursuit

Lower case a to z, 13 ems

ABCDEFGHIJKLMN OPQRSTUVWXYZ

1234567890

11 POINT OLD STYLE NO 84

WHEN, in the course of human events, it becomes necessary for one people to dissolve the political bands which have connected them with another, and to assume, among the powers of the earth, the separate and equal station to which the *laws of nature and of nature's God* entitle them, a decent respect to the opinions of mankind requires that they should declare the causes which impel them to the separation. We hold these truths to be self-evident, that all men are created equal; that they are endowed by their

Lower case a to z, 12½ ems

ABCDEFGHIJKLMN OPQRSTUVWXYZ

1234567890

12 POINT OLD STYLE NO 84

WHEN, in the course of human events, it becomes necessary for one people to dissolve the political bands which have connected them with another, and to assume, *among the powers of the earth*, the separate and equal station to which the laws of nature and of nature's God entitle them, a decent respect to the opinions of mankind requires that they should declare the causes which impel them to the separation. We

Lower case a to z, 12½ ems

ABCDEFGHIJKLMN OPQRSTUVWXYZ

1234567890

Old Style Figures only included in regular fonts. Modern Figures furnished if desired

OLD STYLE ROMAN SERIES No 325

6 POINT OLD STYLE NO 325

WHEN, in the course of human events, it becomes necessary for one people to dissolve the political bands which have connected them with another, and to assume, among the powers of the earth, the separate and equal station to which the laws of nature and of nature's God entitle them, a decent respect to the opinions of mankind requires that they should declare the causes which impel them to the separation. *We hold these truths to be self-evident*, that all men are created equal; that they are endowed by their Creator with certain unalienable rights; that among these, are life, liberty, and the pursuit of happiness. That, to secure these rights, governments are instituted among men, deriving their just powers from the consent of the governed; that, whenever any form of government becomes destructive of these ends, it is the right of the people to alter or to abolish it, and

Lower case a to z, 16½ ems

ABCDEFGHIJKLMNOPQRSTUVWXYZ

1234567890

7 POINT OLD STYLE NO 325

WHEN, in the course of human events, it becomes necessary for one people to dissolve the political bands which have connected them with another, and to assume, among the powers of the earth, the separate and equal station to which the laws of nature and of nature's God entitle them, a decent respect to *the opinions of mankind requires* that they should declare the causes which impel them to the separation. We hold these truths to be self-evident, that all men are created equal; that they are endowed by their Creator with certain unalienable rights; that among these, are life, liberty, and the pursuit of happiness. That, to secure these rights, governments

Lower case a to z, 15 ems

ABCDEFGHIJKLMNOPQRSTUVWXYZ

1234567890

8 POINT OLD STYLE NO 325

WHEN, in the course of human events, it becomes necessary for one people to dissolve the political bands which have connected them with another, and to assume, among the powers of the earth, the separate and equal station to which the laws of nature and of nature's God entitle them, *a decent respect to the opinions* of mankind requires that they should declare the causes which impel them to the separation. We hold these truths to be self-evident, that all men are created equal; that they are endowed by their Creator with certain unalien-

Lower case a to z, 14½ ems

ABCDEFGHIJKLMNOPQRSTUVWXYZ

1234567890

9 POINT OLD STYLE NO 325

WHEN, in the course of human events, it becomes necessary for one people to dissolve the political bands which have connected them with another, and to assume, among the powers of the earth, *the separate and equal station* to which the laws of nature and of nature's God entitle them, a decent respect to the opinions of mankind requires that they should declare the causes which impel them to the separation. We hold these

Lower case a to z, 14 ems

ABCDEFGHIJKLMNOPQRSTUVWXYZ

1234567890

10 POINT OLD STYLE NO 325

WHEN, in the course of human events, it becomes necessary for one people to dissolve the political bands which have connected them with another, and to assume, among the powers of the earth, the separate and equal station to which the laws of nature and of nature's God entitle them, a decent respect to *the opinions of mankind requires* that they should declare the causes which impel them to the separation. We hold these truths to be self-evident, that all men are created equal; that they are endowed by their Creator with certain unalienable rights; that among these, are life, liberty, and the pursuit of happiness. That, to

Lower case a to z, 13 1-5 ems

ABCDEFGHIJKLMNOPQRSTUVWXYZ

1234567890

11 POINT OLD STYLE NO 325

WHEN, in the course of human events, it becomes necessary for one people to dissolve the political bands which have connected them with another, and to assume, among the powers of the earth, the separate and equal station to *which the laws of nature* and of nature's God entitle them, a decent respect to the opinions of mankind requires that they should declare the causes which impel them to the separation. We hold these truths to be self-evident, that all men are created equal; that they are endowed by their Creator with certain

Lower case a to z, 13 1-5 ems

ABCDEFGHIJKLMNOPQRSTUVWXYZ

1234567890

12 POINT OLD STYLE NO 325

WHEN, in the course of human events, it becomes necessary for one people to dissolve the political bands which have connected them with another, and to assume, among the powers of the earth, *the separate and equal station* to which the laws of nature and of nature's God entitle them, a decent respect to the opinions of mankind requires that they should declare the causes which impel them to the

Lower case a to z, 14½ ems

ABCDEFGHIJKLMNOPQRSTUVWXYZ

1234567890

CAXTON OLD STYLE

E

6 POINT CAXTON OLD STYLE

32 A 24 A 100 a \$4 45

WHEN, in the course of human events, it becomes necessary for one people to dissolve the political bands which have connected them with another, and to assume, among the powers of the earth, the separate and equal station to which the laws of nature and of nature's God entitle them, a decent respect to the opinions of mankind requires that they should declare the causes which impel them to the separation. We hold these truths to be self-evident, that all men are created equal; that they are endowed by their Creator with certain unalienable rights; that among these, are life, liberty, and the pursuit of happiness. That, to secure these rights, governments are instituted among men, deriving their just powers from the consent of the governed; that, whenever any form of government becomes destructive of these ends, it is the right of the people to alter or to abolish it, and to institute a new government, laying its foundation on such *principles and organizing its powers* in such form as to them shall seem most likely to effect their safety and happiness. Prudence, indeed, will dictate that governments long established, should not be changed for light and transient causes; and, accordingly, all experience hath shown, that mankind are more disposed to suffer, while evils are sufferable, than to right themselves by abolishing the forms to which they are accustomed. But, when a long train of abuses and usurpations, pursuing invariably the same object, evinces a design to reduce them under absolute despotism, it is their right, it is their duty, to throw off such government, and to provide new guards for their future security. Such has been the patient sufferance of these

Lower case a to z, 18¾ ems

ABCDEFGHIJKLMN OPQRSTUVWXYZ

1234567890

8 POINT CAXTON OLD STYLE

24 A 18 A 64 a \$3 70

WHEN, in the course of human events, it becomes necessary for one people to dissolve the political bands which have connected them with another, and to assume, among the powers of the earth, the separate and equal station to which the laws of nature and of nature's God entitle them, a decent respect to the opinions of mankind requires that they should declare the causes which impel them to the separation. We hold these truths to be self-evident, that all men are created equal; that they are endowed by their Creator with certain unalienable rights; that among these, are life, liberty, and the pursuit of happiness. That, to secure these rights, governments *are instituted among men, deriving* their just powers from the consent of the governed; that, whenever any form of government becomes destructive of these ends, it is the right of the people to alter or to abolish it, and to institute a new government, laying its foundation on such principles, and organizing its powers in such form, as to them shall seem most likely to effect their safety and happiness.

Lower case a to z, 16½ ems

ABCDEFGHIJKLMN OPQRSTUVWXYZ

1234567890

10 POINT CAXTON OLD STYLE

18 A 12 A 50 a \$3 50

WHEN, in the course of human events, it becomes necessary for one people to dissolve the political bands which have connected them with another, and to assume, among the powers of the earth, the separate and equal station to which the laws of nature and of nature's God entitle them, a decent respect to the opinions of *mankind requires that they* should declare the causes which impel them to the separation. We hold these truths to be self-evident, that all men are created equal; that they are endowed by their Creator with certain unalienable rights; that among these, are life, liberty, and the pursuit of happiness. That, to secure these rights, governments are instituted among men, deriving their just powers from the consent of the governed; that, whenever any form of government becomes destructive of these ends, it is the right of the people to alter or to abolish it, and

Lower case a to z, 15½ ems

ABCDEFGHIJKLMNOPQRSTUVWXYZ
1234567890

12 POINT CAXTON OLD STYLE

18 A 12 A 50 a \$4 75

WHEN, in the course of human events, it becomes necessary for one people to dissolve the political bands which have connected them with another, and to assume, among the powers of the *earth, the separate and equal* station to which the laws of nature and of nature's God entitle them, a decent respect to the opinions of mankind requires that they should declare the causes which impel them to the separation. We hold these truths to be self-evident, that all men are created equal; that they are endowed by their Creator with certain unalienable rights; that among these, are life, liberty, and the pursuit of happiness.

Lower case a to z, 14½ ems

ABCDEFGHIJKLMNOPQRSTUVWXYZ
1234567890

Larger sizes of this series are shown on pages 491-491^a

FRENCH ELZEVIR No 1

8 POINT FRENCH ELZEVIR No 1

ITALIC 28 A 80 a \$3 00 40 A 20 A 90 a \$4 00

WHEN, in the course of human events, it becomes necessary for one people to dissolve the political bands which have connected them with another, and to assume, among the powers of the earth, the separate and equal station to which the laws of nature and of nature's God entitle them, a decent respect to the opinions of mankind requires that they should declare the causes which impel them to the separation. We hold these truths to be self-evident, that all men are created equal; that they are endowed by their Creator with certain unalienable rights; that among these, are life, liberty, and the pursuit of happiness. That, to secure these rights, governments are instituted among men, deriving their just powers from the consent of the governed; that, whenever any government becomes *destructive of these ends, it is the right* of the people to alter or to abolish it, and to institute a new government, laying its foundation on such principles, and organizing its powers in such form, as to them shall seem most likely to effect their safety and happiness. Prudence, indeed, will dictate that governments long established, should not be changed for light and transient causes; and, accordingly, all experience hath shown, that mankind are more disposed to suffer, while evils are sufferable, than to right themselves by abolishing the forms to which they are accustomed. But, when a long train of

Lower case a to z, 12¾ ems

ABCDEFGHIJKLMN O PQRSTU VWXYZ

1 2 3 4 5 6 7 8 9 0

10 POINT FRENCH ELZEVIR No 1

ITALIC 28 A 80 a \$3 80 40 A 20 A 80 a \$4 75

WHEN, in the course of human events, it becomes necessary for one people to dissolve the political bands which have connected them with another, and to assume, among the powers of the earth, the separate and equal station to which the laws of nature and of nature's God entitle them, a decent respect to the opinions of mankind requires that they should declare the causes which impel them to the separation. We hold these truths to be self-evident, that all men are created equal; that they are endowed by their Creator with certain unalienable rights; *that among these, are life, liberty,* and the pursuit of happiness. That, to secure these rights, governments are instituted among men, deriving their just powers from the consent of the governed; that, whenever any government becomes destructive of these ends, it is the right of the people to alter or to abolish it, and to institute a new government, laying its

Lower case a to z, 12 ems

ABCDEFGHIJKLMN O PQRSTU VWXYZ

1 2 3 4 5 6 7 8 9 0

12 POINT FRENCH ELZEVIR NO 1

ITALIC 20 A 50 a \$3 94 28 A 16 A 62 a \$5 00

WHEN, in the course of human events, it becomes necessary for one people to dissolve the political bands which have connected them with another, and to assume, among the powers of the earth, the separate and equal station to which the laws of nature and of nature's God entitle them, a decent respect to the opinions of mankind requires that they should declare the causes *which impel them to the separation*. We hold these truths to be self-evident, that all men are created equal; that they are endowed by their Creator with certain unalienable rights; that among these, are life, liberty, and the pursuit of happiness. That, to secure

Lower case a to z, 12½ ems

ABCDEFGHIJKLMNOPQRSTUVWXYZ
1 2 3 4 5 6 7 8 9 0

14 POINT FRENCH ELZEVIR NO 1

ITALIC 16 A 36 a \$3 90 20 A 10 A 50 a \$5 00

WHEN, in the course of human events, it becomes necessary for one people to dissolve the political bands which have connected them with another, and to assume, among the powers of the earth, the separate and equal station to which the laws of nature and of nature's God *entitle them, a decent respect* to the opinion of mankind requires that they should declare the causes which impel them to the separation. We hold these truths to be self-evident, that all men are created equal; that they are en-

ABCDEFGHIJKLMNOPQRSTUVWXYZ
1 2 3 4 5 6 7 8 9 0

FRENCH OLD STYLE No 2

6 POINT FRENCH OLD STYLE NO 2

30 A \$1 25 30 A 20 A 100 a \$4 00

WHEN, in the course of human events, it becomes necessary for one people to dissolve the political bands which have connected them with another, and to assume, among the powers of the earth, the separate and equal station to which the laws of nature and of nature's God entitle them, a decent respect to the opinions of mankind requires that they should declare the causes which impel them to the separation. We hold these truths to be self-evident, that all men are created equal; that they are endowed by their Creator with certain unalienable rights; that among these, are life, liberty, and the pursuit of happiness. That, to secure these rights, governments are instituted among men, deriving their just powers from the consent of the governed; that, whenever any form of government becomes destruc-

tive of these ends, it is the right of the people to alter or to abolish it, and to institute a new government, laying its foundation on such principles, and organizing its powers in such form, as to them shall seem most likely to effect their safety and happiness. Prudence, indeed, will dictate that governments long established, should not be changed for light and transient causes; and, accordingly, all experience hath shown, that mankind are more disposed to suffer, while evils are sufferable, than to right themselves by abolishing the forms to which they are accustomed. But, when a long train of abuses and usurpations, pursuing invariably the same object, evinces a design to reduce

Lower case a to z, 14 ems

ABCDEFGHIJKLMN OPQRSTUVWXYZ

1234567890

7 POINT FRENCH OLD STYLE NO 2

30 A \$1 60 30 A 15 A 90 a \$4 60

WHEN, in the course of human events, it becomes necessary for one people to dissolve the political bands which have connected them with another, and to assume, among the powers of the earth, the separate and equal station to which the laws of nature and of nature's God entitle them, a decent respect to the opinions of mankind requires that they should declare the causes which impel them to the separation. We hold these truths to be self-evident, that all men are created equal; that they are endowed by their Creator with certain unalienable rights; that among these, are life, liberty, and the pursuit of happiness. That, to secure these rights, governments are instituted among men, deriving their just powers from the consent of the governed; that, whenever any form of government becomes destructive of these ends, it is the right of the people to alter or to abolish it, and to institute a new government, laying its foundation on such principles, and organizing its powers in such form, as to them shall

Lower case a to z, 14½ ems

ABCDEFGHIJKLMN OPQRSTUVWXYZ

1234567890

8 POINT FRENCH OLD STYLE NO 2

30 A \$1 65 30 A 15 A 90 a \$4 60

WHEN, in the course of human events, it becomes necessary for one people to dissolve the political bands which have connected them with another, and to assume, among the powers of the earth, the separate and equal station to which the laws of nature and of nature's God entitle them, a decent respect to the opinions of mankind requires that they should declare the causes which impel them to the separation. We hold these truths to be self-evident, that all men are created equal; that they are endowed by their Creator with certain unalienable rights; that among these, are life, liberty, and the pursuit of happiness. That, to secure these rights, governments are instituted among men, deriving their just powers from the consent of the governed; that, whenever any form of

Lower case a to z, 13¾ ems

ABCDEFGHIJKLMN OPQRSTUVWXYZ

1234567890

10 POINT FRENCH OLD STYLE NO 2

24 A \$1 60 24 A 12 A 75 a \$4 70

WHEN, in the course of human events, it becomes necessary for one people to dissolve the political bands which have connected them with another, and to assume, among the powers of the earth, the separate and equal station to which the laws of nature and of nature's God entitle them, a decent respect to the opinions of mankind requires that they should declare the causes which impel them to the separation. We hold these truths to be self-evident, that all men are created equal; that they are endowed by their Creator with certain unalienable rights; that among these, are life, liberty, and the pursuit of happiness. That, to secure these rights, governments are instituted among men, deriving their just powers from the consent of the governed; that, whenever any form of government becomes destructive of these ends, it is the right of the people to alter or to abolish it, and to institute a new government, laying its foundation on such principles, and organizing

Lower case a to z, 12 $\frac{3}{4}$ ems

ABCDEFGHIJKLMN OPQRSTUVWXYZ

1234567890

12 POINT FRENCH OLD STYLE NO 2

20 A \$1 55 20 A 10 A 60 a \$5 00

WHEN, in the course of human events, it becomes necessary for one people to dissolve the political bands which have connected them with another, and to assume, among the powers of the earth, the separate and equal station to which the laws of nature and of nature's God entitle them, a decent respect to the opinions of mankind requires that they should declare the causes which impel them to the separation. We hold these truths to be self-evident, that all men are created equal; that they are endowed by their Creator with certain unalienable rights; that among these, are life, liberty, and the pursuit of happiness. That, to secure these rights, governments are instituted among men, de-

Lower case a to z, 13 ems

ABCDEFGHIJKLMN OPQRSTUVWXYZ

1234567890

Larger sizes of this series are shown on pages 492-494

CUSHING SERIES

6 POINT CUSHING

20 A 12 A 50 a \$3 50

WHEN, in the course of human events, it becomes necessary for one people to dissolve the political bands which have connected them with another, and to assume, among the powers of the earth, the separate and equal station to which the laws of nature and of nature's God entitle them, a decent respect to the opinions of mankind requires that they should declare the causes which impel them to the separation. We hold these truths to be self evident that all men are created equal; that they are endowed by their Creator with certain unalienable rights; that among these, are life, liberty, and the pursuit of happiness. That, to secure these rights, governments are instituted among men, deriving their just powers from the consent of the governed; that, whenever any form of government becomes destructive of these ends, it is the right of the people to alter or to abolish it, and to institute a new government, laying its foundation on such principles, and organizing its powers in such form, as to them shall seem most likely to effect their safety and happiness. Prudence, indeed, will dictate that governments long established, should not be changed for *light and transient causes; and, accordingly, all experience hath shown, that mankind are*

Lower case a to z, 13 $\frac{3}{8}$ ems

ABCDEFGHIJKLMNPOQRSTUVWXYZ

1234567890

8 POINT CUSHING

20 A 12 A 44 a \$4 00

WHEN, in the course of human events, it becomes necessary for one people to dissolve the political bands which have connected them with another, and to assume, among the powers of the earth, the separate and equal station to which the laws of nature and of nature's God entitle them, a decent respect to the opinions of mankind requires that they should declare the causes which impel them to the separation. We hold these truths to be self-evident that all men are created equal; that they are endowed by their Creator with certain unalienable rights; that among these, are life, liberty, and the pursuit of happiness. That, to secure these rights, governments are instituted among men, deriving their just powers from the consent of the governed; that, whenever any form of government becomes destructive of these ends, it is the right of the people to alter or to abolish it, and *to institute a new government, laying its foundation on such principles and organ-*

Lower case a to z, 12 $\frac{7}{8}$ ems

ABCDEFGHIJKLMNPOQRSTUVWXYZ

1234567890

10 POINT CUSHING

16 A 10 A 40 a \$4 50

WHEN, in the course of human events, it becomes necessary for one people to dissolve the political bands which have connected them with another, and to assume, among the powers of the earth, the separate and equal station to which the laws of nature and of nature's God entitle them, a decent respect to the opinions of mankind requires that they should declare the causes which impel them to the separation. We hold these truths to be self-evident, that all men are created equal; that they are endowed by their Creator with certain unalienable rights; that among *these, are life, liberty, and the pursuit of happiness. That, to secure*

Lower case a to z, 11 $\frac{1}{4}$ ems

ABCDEFGHIJKLMNPOQRSTUVWXYZ

1234567890

12 POINT CUSHING

14 A 8 A 36 a \$5 00

WHEN, in the course of human events, it becomes necessary for one people to dissolve the political bands which have connected them with another, and to assume, among the powers of the earth, the separate and equal station to which the laws of nature and of nature's God entitle them, a decent respect to the opinions of mankind requires that they should declare the causes which impel them to the separation. We hold these truths to be self-evident, that all men are created equal; that they are endowed by their Creator with certain unalienable rights; that among these, are life, liberty, and the pursuit of happiness. That, to secure these rights, governments *are instituted among men, deriving their right to govern*

Lower case a to z, 12 ems

ABCDEFGHIJKLMNOPQRSTUVWXYZ
1234567890

15 POINT CUSHING

15 A 25 a \$3 50

When, in the course of human events, it becomes necessary for one people to dissolve the political bands which have connected them with another, and to assume, among the powers of the earth, the separate and equal station to which the laws of nature and of nature's God entitle them, a decent respect to the opinions of mankind requires that they *should declare the causes which impel them*

Lower case a to z, 13 5-6 ems

ABCDEFGHIJKLMNOPQRSTUVWXYZ
1234567890

Larger sizes of this series are shown on page 414

CUSHING MONOTONE

8 POINT CUSHING MONOTONE

WHEN, in the course of human events, it becomes necessary for one people to dissolve the political bands which have connected them with another, and to assume, among the powers of the earth, the separate and equal station to which the laws of nature and of nature's God entitle them, a decent respect to the opinions of mankind requires that they should declare the causes which impel them to the separation. We hold these truths to be self-evident, that all men are created equal; that they are endowed by their Creator with certain unalienable rights; that among these, are life, liberty, and the pursuit of happiness. That, to secure these rights, governments are instituted among men, deriving their just powers from the consent of the governed; that, whenever any form of government becomes destructive of these ends, it is the right of the people to alter or to abolish it, and to institute a new government, laying its foundation on such principles, and organizing its powers in such form, as to them shall seem most likely to effect their safety and happiness. Prudence, indeed, will dictate that governments long established, should not be changed for light and transient causes; and, accordingly, all experience hath shown, that mankind are more disposed to suffer, while evils are sufferable, than to right themselves by abolishing the forms to which they are accustomed. But, when a long train of abuses and usurpations, pursuing invariably the same object, evinces a design to reduce them under absolute despotism, it is their right, it is their duty, to throw off such government, and to provide new guards for their future security. Such has been the patient sufferance of these colonies, and such is now the necessity which con-

Lower case a to z, 12¼ ems

ABCDEFGHIJKLMNOPQRSTUVWXYZ

1234567890

10 POINT CUSHING MONOTONE

WHEN, in the course of human events, it becomes necessary for one people to dissolve the political bands which have connected them with another, and to assume, among the powers of the earth, the separate and equal station to which the laws of nature and of nature's God entitle them, a decent respect to the opinions of mankind requires that they should declare the causes which impel them to the separation. We hold these truths to be self-evident, that all men are created equal; that they are endowed by their Creator with certain unalienable rights; that among these, are life, liberty, and the pursuit of happiness. That, to secure these rights, governments are instituted among men, deriving their just powers from the consent of the governed; that, whenever any form of government becomes destructive of these ends, it is the right of the people to alter or to abolish it, and to institute a new government, laying its foundation on such principles, and organizing its powers in such form, as to them shall seem most likely to effect their safety and happiness. Prudence, indeed, will dictate that governments

Lower case a to z, 12¼ ems

ABCDEFGHIJKLMNOPQRSTUVWXYZ

1234567890

10 POINT CUSHING MONOTONE NO 2

When, in the course of human events, it becomes necessary for one people to dissolve the political bands which have connected them with another, and to assume, among the powers of the earth, the separate and equal station to which the laws of nature and of nature's God entitle them, a decent respect to the opinions of mankind requires that they should declare the causes which impel them to the separation. We hold these truths to be self-evident, that all men are created equal; that they are endowed by their Creator with certain unalienable rights; that among these, are life, liberty, and the pursuit of happiness. That, to secure these rights, governments are instituted among men, deriving their just powers from the consent of the governed; that, whenever any form of government becomes destructive of these ends, it is the right of the people to alter or to abolish it, and to institute a new government, laying its foundation on such principles, and organizing

Lower case a to z, 13 $\frac{5}{8}$ ems

ABCDEFGHIJKLMN OPQRSTUVWXYZ

1234567890

11 POINT CUSHING MONOTONE

When, in the course of human events, it becomes necessary for one people to dissolve the political bands which have connected them with another, and to assume, among the powers of the earth, the separate and equal station to which the laws of nature and of nature's God entitle them, a decent respect to the opinions of mankind requires that they should declare the causes which impel them to the separation. We hold these truths to be self-evident, that all men are created equal; that they are endowed by their Creator with certain unalienable rights; that among these, are life, liberty, and the pursuit of happiness. That, to secure these rights, governments are instituted among men, deriving their just powers from the consent of the governed; that, whenever any form of government becomes destructive of these ends, it is the right of the people to alter or to abolish it, and to institute a new government, laying its foundation on such principles, and organizing its powers in such form, as

Lower case a to z, 11 $\frac{5}{8}$ ems

ABCDEFGHIJKLMN OPQRSTUVWXYZ

1234567890

DESCRIPTION OF SELF SPACING TYPE

SELF SPACING TYPE IS MADE UNDER PATENTS ISSUED DECEMBER 18, 1883

THE common widths of book pages, miscellaneous jobs and newspaper columns are some number of Pica ems, therefore the Pica em is taken as the basis for Self Spacing type. The thinnest space in all fonts is some exact fraction of a Pica, and this fraction of Pica is called the unit of measure. All characters, spaces and quads in the font are made some exact multiple of this unit in width, so that the sizes of all faces will work perfectly together in the regular labor-saving measures. This unit of measure may be one-sixth, one-seventh, one-eighth, one-ninth, etc., of a Pica em, as may be desired, to produce condensed, medium or extended faces. The following table gives the sizes of bodies, units of measure, and lengths of alphabets. In the first column will be found the various sizes of bodies; in the second, the number of units contained in one em Pica, and in the third the measurements of a lower case alphabet in the ems of each particular body:

| BODY | Number Units to Pica em | Length of Alphabet |
|--------------------------|-------------------------------|--------------------------|
| 5½ Point (Agate)..... | 12 | 167⁄8 |
| 6 Point (Nonpareil)... | 12 | 151⁄2 |
| 6 Point (Nonpareil)... | 11 | 17 |
| 7 Point (Minion)..... | 11 | 141⁄2 |
| 7 Point (Minion)..... | 10 | 16 |
| 8 Point (Brevier)..... | 11 | 125⁄8 |
| 8 Point (Brevier)..... | 10 | 141⁄8 |
| 8 Point (Brevier)..... | 9 | 151⁄2 |
| 9 Point (Bourgeois)... | 10 | 123⁄8 |
| 9 Point (Bourgeois)... | 9 | 133⁄4 |
| 10 Point (Lg. Primer)... | 9 | 123⁄8 |
| 10 Point (Lg. Primer)... | 8 | 14 |
| 11 Point (Small Pica)... | 8 | 122⁄3 |
| 11 Point (Small Pica)... | 7 | 141⁄2 |
| 12 Point (Pica)..... | 7 | 131⁄4 |

In the foregoing table will be found a Nonpareil with one-twelfth of Pica as the unit of measure. This is one-sixth of the body of Nonpareil, or the six-to-em space, and preserves in this particular font the old three-to-em space and the old en and em

quads. The same is true of the Brevier on one-ninth, Bourgeois on one-eighth, and Pica on one-sixth of Pica.

In a complete font of the old kind of body type there are about 190 widths of bodies. Appended is a table showing the different widths of bodies of Self Spacing. It will be readily seen that there are but nine widths of bodies all told, and that the four-unit width predominates largely over any other, there being fifty-nine characters of this width. We omit the Italic characters from the table, as they go on the same widths of bodies and are interchangeable with the Roman:

| | |
|---|-----|
| 1 unit —Space..... | 1 |
| 2 units—Space, f i j l , : ; . - ' ! I J ' | 16 |
| 3 units—Quad, c e r s t z s z I J ?) [* † ‡ § ¶ ¨ ° | 22 |
| 4 units—Quad, a b d g h k n o p q u v x y f i f l f f \$ £ 1 2 3 4 5 6 7 8 9 O A B C D E F G L N O P Q R T U V X Y & S Z . - { } \ / | 59 |
| 5 units—æ A B C D E F G L N O P Q R T U V Y H K M..... | 21 |
| 6 units—Quad, m w œ w Æ œ f i f l H K X & I b P @ — ... ¼ ½ ¾ ⅓ ⅔ ⅕ ⅖ ⅗ ⅘ | 27 |
| 7 units—W M..... | 2 |
| 8 units—Œ Æ..... | 2 |
| 12 units—Quad, — | 5 |
| 9 sizes. Roman characters..... | 155 |
| Italic characters..... | 77 |
| Total..... | 232 |

Any compositor can see that no combination of units can be made that will not come within a certain number of exact units of filling a line. If a line of matter lacks, it must lack one or more exact units.

Self Spacing type sets line for line with the ordinary Roman, where the lengths of the alphabets are the same.

Repeated experiments with the new type have shown that the average compositor gains about twenty-five per cent. in speed, with no trouble in justification whatever.

In the matter of the correction of proofs the gain is enormous. Say there is an "a" for "e"; as "a" is four units wide and "e" three, "e" and one unit space justify the line perfectly. Even this measure of trouble is avoided in many instances. As twenty-eight of the most common lower case characters are of the same width, they can be substituted for one another without the change of a space.

This type is of greater durability, as it is always on its feet and is therefore not worn by "pounding."

In tabular work there is a great gain in speed and neatness. By the addition of a new character, viz: "|", it is easy to set perpendicular lines of any length, line upon line.

It may be repeated that the compositor has nothing to learn in Self Spacing type. There is but a single direction to be given—to set that which looks like the em quad (six unit quad) with the nick out.

Whoever will study the principle on which Self Spacing type is based, will readily admit that it is bound to secure easy and perfect justification, greatly increased speed and consequent enormous saving, simplicity and rapidity of proof correction, and increased accuracy and ease in the setting of tables. All these points are beyond question, as certainly as the proposition that two and two make four is not open to argument. No rational person can doubt them.

The following piece of composition was done in a 12½-em measure stick, and set line upon line in the ordinary manner of straight reading matter, the lower part being leaded to show the method of setting:

| No. 1 | No. 2 | No. 3 | No. 4 | No. 5 | No. 6 | No. 7 |
|---------|--------|-------|-----------|--------|-------|--------|
| i and | I HX | I DLE | s aturds | i MP | I dim | ' D1N |
| s mit | I NK | s MIT | is thmui | s NK | s mit | s MIT |
| b rot | S LY | B AIT | ne ver fr | d LY | B rot | S AIT |
| si tly | E LS | M ine | Th ursci | si LS | M tly | E RK |
| m an | H IE | L ED | line forn | m IE | L nd | H AD |
| su it; | SI SI | SE ES | nine five | so IS | SE at | SI LS |
| no ts | NI X | PU ss | incre asi | mi X | PA st | BI ts |
| No is | SA T | No is | comp oz | ME T | MA D | SU it |
| gl ad | FO Z | FL T | Repea ti | gl a | S BIN | S FO x |
| mit e | OH I | SEA S | second r | snil I | SEA I | HO e |
| still i | \$34 ! | NOT I | beat th | this I | NOT ! | 234 I |

To further explain and illustrate the ease with which table work is done with Self Spacing type, we show above an example of miscellaneous justifications, which is absolutely impossible to accomplish with the old kind of type. In column No. 1 the first line begins with the lower case "i", two units wide, which is followed by the upright dash "|", two units, and the characters "a", four units, "n", four units, "d", four units, comprising sixteen units to accurately fill the column. The second line begins with the letter "s," three units wide, which throws the space rule one unit further to the right than in the preceding line. In each succeeding line lower case characters are used to the total width of sixteen units, and such characters are chosen for the first part thereof as will admit of advancing the space rule to the right exactly one unit in each succeeding line.

In the other columns the same plan is followed, the only change being the substitution of caps, small caps, figures, etc., for the lower case characters, all columns coming perfectly justified inside the perpendicular lines.

SELF SPACING SIGNS

These signs are furnished for every face of Self Spacing type, and may be used with point system bodies. When ordering state size of body and (if Self Spacing) number of face wanted.

PRICE \$1 00 PER FONT EACH SIZE

| | | | | | | | | | | | | | | | | | | | | | | | | |
|---|---|---|---|---|---|----|---|---|---|---|---|---|---|---|---|---|---|---|---|---|---|---|---|---|
| × | + | - | = | ± | : | :: | ÷ | ≐ | < | > | △ | □ | √ | ∛ | ℞ | ℔ | ℥ | ℥ | % | % | ¢ | ⊠ | ⋈ | † |
| × | + | - | = | ± | : | :: | ÷ | ≐ | < | > | △ | □ | √ | ∛ | ℞ | ℔ | ℥ | ℥ | % | % | ¢ | ⊠ | ⋈ | † |
| × | + | - | = | ± | : | :: | ÷ | ≐ | < | > | △ | □ | √ | ∛ | ℞ | ℔ | ℥ | ℥ | % | % | ¢ | ⊠ | ⋈ | † |
| × | + | - | = | ± | : | :: | ÷ | ≐ | < | > | △ | □ | √ | ∛ | ℞ | ℔ | ℥ | ℥ | % | % | ¢ | ⊠ | ⋈ | † |
| × | + | - | = | ± | : | :: | ÷ | ≐ | < | > | △ | □ | √ | ∛ | ℞ | ℔ | ℥ | ℥ | % | % | ¢ | ⊠ | ⋈ | † |
| × | + | - | = | ± | : | :: | ÷ | ≐ | < | > | △ | □ | √ | ∛ | ℞ | ℔ | ℥ | ℥ | % | % | ¢ | ⊠ | ⋈ | † |

SELF SPACING MODERN ROMANS

For description of Self Spacing Modern Roman and Old Style, see pages 128 and 129

5½ POINT SELF SPACING NO 19½

Unit of measure, 12 to Pica

WHEN, in the course of human events, it becomes necessary for one people to dissolve the political bands which have connected them with another, and to assume, among the powers of the earth, the separate and equal station to which the laws of nature and of nature's God entitle them, a decent respect to the opinions of mankind requires that they should declare the causes which impel them to the separation. We hold these truths to be self-evident, that all men are created equal; that they are endowed by their Creator with certain unalienable rights; that among these, are life, liberty, and the pursuit of happiness. That, to secure these rights, governments are instituted among men, deriving their just powers from the consent of the governed; that, whenever any form of government becomes destructive of these ends, it is the right of the people to alter or to abolish it, and to institute a new government, laying its foundation on such principles, and organizing its powers in such form, as to them shall seem most likely to effect their safety and happiness. Prudence, indeed, will dictate that governments long established, should not be changed for light and transient causes; and, accordingly, all experience hath shown, that mankind are more disposed to suffer, while evils are sufferable, than to right themselves by abolishing the forms to which they are accustomed. But, when a long train of abuses and usurpations, pursuing invariably the same object, evinces a design to reduce them under absolute despotism, it is their right, it is their duty, to throw off such government, and to provide new guards for their future security.

Lower case a to z, 16½ ems

ABCDEFGHIJKLMN OPQRSTUVWXYZ

1234567890

6 POINT SELF SPACING NO 20½

Unit of measure, 12 to Pica

WHEN, in the course of human events, it becomes necessary for one people to dissolve the political bands which have connected them with another, and to assume, among the powers of the earth, the separate and equal station to which the laws of nature and of nature's God entitle them, a decent respect to the opinions of mankind requires that they should declare the causes which impel them to the separation. We hold these truths to be self-evident, that all men are created equal; that they are endowed by their Creator with certain unalienable rights; that among these, are life, liberty, and the pursuit of happiness. That, to secure these rights, governments are instituted among men, deriving their just powers from the consent of the governed; that, whenever any form of government becomes destructive of these ends, it is the right of the people to alter or to abolish it, and to institute a new government, laying its foundation on such principles, and organizing its powers in such form, as to them shall seem most likely to effect their safety and happiness. Prudence, indeed, will dictate that governments long established, should not be changed for light and transient causes; and, accordingly, all experience hath shown, that mankind are more disposed to suffer, while evils are sufferable, than to right themselves by abolishing the forms to which they are accustomed. But, when a long train of abuses and usurpations, pursuing invariably the same object, evinces

Lower case a to z, 15½ ems

ABCDEFGHIJKLMN OPQRSTUVWXYZ

1234567890

6 POINT SELF SPACING NO 36½

Unit of measure, 12 to Pica

WHEN, in the course of human events, it becomes necessary for one people to dissolve the political bands which have connected them with another, and to assume, among the powers of the earth, the separate and equal station to which the laws of nature and of nature's God entitle them, a decent respect to the opinions of mankind requires that they should declare the causes which impel them to the separation. We hold these truths to be self-evident, that all men are created equal; that they are endowed by their Creator with certain unalienable rights; that among these, are life, liberty, and the pursuit of happiness. That, to secure these rights, governments are instituted among men, deriving their just powers from the consent of the governed; that, whenever any form of government becomes destructive of these ends, it is the right of the people to alter or to abolish it, and to institute a new government, laying its foundation on such principles, and organizing its powers in such form, as to them shall seem most likely to effect their safety and happiness. Prudence, indeed, will dictate that governments long established, should not be changed for light and transient causes; and, accordingly, all experience hath shown, that mankind are more disposed to suffer, while evils are sufferable, than to right themselves by abolishing the forms to which they are accustomed. But, when a long train of abuses and usurpations, pursuing invariably the same object, evinces

Lower case a to z, 15½ ems

ABCDEFGHIJKLMN OPQRSTUVWXYZ

1234567890

6 POINT SELF SPACING NO 37½

Unit of measure, 11 to Pica

WHEN, in the course of human events, it becomes necessary for one people to dissolve the political bands which have connected them with another, and to assume, among the powers of the earth, the separate and equal station to which the laws of nature and of nature's God entitle them, a decent respect to the opinions of mankind requires that they should declare the causes which impel them to the separation. We hold these truths to be self-evident, that all men are created equal; that they are endowed by their Creator with certain unalienable rights; that among these, are life, liberty, and the pursuit of happiness. That, to secure these rights, governments are instituted among men, deriving their just powers from the consent of the governed; that, whenever any form of government becomes destructive of these ends, it is the right of the people to alter or to abolish it, and to institute a new government, laying its foundation on such principles, and organizing its powers in such form, as to them shall seem most likely to effect their safety and happiness. Prudence, indeed, will dictate that governments long established, should not be changed for light and transient causes; and, accordingly, all experience hath shown, that mankind are more disposed to suffer, while evils are sufferable, than to right themselves by abolishing the forms to which they are accustomed. But, when a long train of usurpations and abuses, pursuing invariably the same object, evinces a design to reduce them under absolute despotism, it is their right, it is their duty, to throw off such government, and to provide new guards for their future security. Such has been the patient sufferance of these colonies, and such is now the necessity which constrains them to alter their former systems of government. The history of the present king of Great Britain is a history of repeated injuries and usurpations, all having in direct object the establishment of an absolute tyranny over these States. To prove this, let facts be submitted to a candid world: He has refused his assent to laws the most wholesome and necessary for the public good. He has forbidden his governors to pass laws of immediate and pressing importance, unless suspended in their operation till his assent should be obtained; and, when so suspended, he has utterly neglected to attend to them. He has refused to pass other laws for the accommodation of large districts of people, unless those people would relinquish the

Lower case a to z, 17 ems

ABCDEFGHIJKLMNOPQRSTUVWXYZ
1234567890

7 POINT SELF SPACING NO 23½

Unit of measure, 11 to Pica

WHEN, in the course of human events, it becomes necessary for one people to dissolve the political bands which have connected them with another, and to assume, among the powers of the earth, the separate and equal station to which the laws of nature and of nature's God entitle them, a decent respect to the opinions of mankind requires that they should declare the causes which impel them to the separation. We hold these truths to be self-evident, that all men are created equal; that they are endowed by their Creator with certain unalienable rights; that among these, are life, liberty, and the pursuit of happiness. That, to secure these rights, governments are instituted among men, deriving their just powers from the consent of the governed; that, whenever any form of government becomes destructive of these ends, it is the right of the people to alter or to abolish it, and to institute a new government, laying its foundation on such principles, and organizing its powers in such form, as to them shall seem most likely to effect their safety and happiness. Prudence, indeed, will dictate that governments long established, should not be changed for light and transient causes; and, accordingly, all experience hath shown, that mankind are more disposed to suffer, while evils are sufferable, than to right themselves by abolishing the forms to which they are accustomed. But, when a long train of usurpations and abuses, pursuing invariably the same object, evinces a design to reduce them under absolute despotism, it is their right, it is their duty, to throw off such government, and to provide new guards for their future security. Such has been the patient sufferance of these colonies, and such is now the necessity which constrains them to alter their former systems of government. The history of the present king of Great Britain is a history of repeated injuries and usurpations, all having in direct object the establishment of an absolute tyranny over these States. To prove this, let facts be submitted to a candid world: He has refused his assent to laws the most wholesome and necessary for the public good. He has forbidden his governors to pass laws of imme-

Lower case a to z, 14½ ems

ABCDEFGHIJKLMNOPQRSTUVWXYZ
1234567890

7 POINT SELF SPACING NO 38½

Unit of measure, 10 to Pica

WHEN, in the course of human events, it becomes necessary for one people to dissolve the political bands which have connected them with another, and to assume, among the powers of the earth, the separate and equal station to which the laws of nature and of nature's God entitle them, a decent respect to the opinions of mankind requires that they should declare the causes which impel them to the separation. We hold these truths to be self-evident, that all men are created equal; that they are endowed by their Creator with certain unalienable rights; that among these, are life, liberty, and the pursuit of happiness. That, to secure these rights, governments are instituted among men, deriving their just powers from the consent of the governed; that, whenever any form of government becomes destructive of these ends, it is the right of the people to alter or to abolish it, and to institute a new government, laying its foundation on such principles, and organizing its powers in such form, as to them shall seem most likely to effect their safety and happiness. Prudence, indeed, will dictate that governments long established, should not be changed for light and transient causes; and, accordingly, all experience hath shown, that mankind are more disposed to suffer, while evils are sufferable, than to right themselves by abolishing the forms to which they are accustomed. But, when a long train of abuses and usurpations, pursuing invariably the same object, evinces a design to reduce them under absolute despotism, it is their right, it is their duty, to throw off such government, and to provide new guards for their future security. Such has been the patient sufferance of these colonies, and such is now the necessity which constrains them to alter their former systems of government. *The history of the present king of Great Britain is a history of repeated injuries and usurpations, all*

Lower case a to z, 16 ems

ABCDEFGHIJKLMN OPQRSTUVWXYZ
1234567890

8 POINT SELF SPACING NO 18½

Unit of measure, 10 to Pica

WHEN, in the course of human events, it becomes necessary for one people to dissolve the political bands which have connected them with another, and to assume, among the powers of the earth, the separate and equal station to which the laws of nature and of nature's God entitle them, a decent respect to the opinions of mankind requires that they should declare the causes which impel them to the separation. We hold these truths to be self-evident, that all men are created equal; that they are endowed by their Creator with certain unalienable rights; that among these, are life, liberty, and the pursuit of happiness. That, to secure these rights, governments are instituted among men, deriving their just powers from the consent of the governed; that, whenever any form of government becomes destructive of these ends, it is the right of the people to alter or to abolish it, and to institute a new government, laying its foundation on such principles, and organizing its powers in such form, as to them shall seem most likely to effect their safety and happiness. Prudence, indeed, will dictate that governments long established, should not be changed for light and transient causes; and, accordingly, all experience hath shown, that mankind are more disposed to suffer, while evils are sufferable, than to right themselves by abolishing the forms to which they are accustomed. But, when a long train of abuses and usurpations, pursuing invariably the same object, evinces a design to reduce them under absolute despotism, it is their right, it is their duty, to *throw off such government, and to provide new guards for their future security. Such has been the patient sufferance of these colonies*

Lower case a to z, 14½ ems

ABCDEFGHIJKLMN OPQRSTUVWXYZ
1234567890

8 POINT SELF SPACING NO 34½

Unit of measure, 10 to Pica

WHEN, in the course of human events, it becomes necessary for one people to dissolve the political bands which have connected them with another, and to assume, among the powers of the earth, the separate and equal station to which the laws of nature and of nature's God entitle them, a decent respect to the opinions of mankind requires that they should declare the causes which impel them to the separation. We hold these truths to be self-evident, that all men are created equal; that they are endowed by their Creator with certain unalienable rights; that among these, are life, liberty, and the pursuit of happiness. That, to secure these rights, governments are instituted among men, deriving their just powers from the consent of the governed; that, whenever any form of government becomes destructive of these ends, it is the right of the people to alter or to abolish it, and to institute a new government, laying its foundation on such principles, and organizing its powers in such form, as to them shall seem most likely to effect their safety and happiness. Prudence, indeed, will dictate that governments long established, should not be changed for light and transient causes; and, accordingly, all experience hath shown, that mankind are more disposed to suffer, while evils are sufferable, than to right themselves by abolishing the forms to which they are accustomed. But, when a long train of abuses and usurpations, pursuing invariably the same object, evinces a design to reduce them under absolute despotism, it is their right, it is their duty, to throw off such government, and to provide new guards for their future

Lower case a to z, 14½ ems

ABCDEFGHIJKLMNOPQRSTUVWXYZ
1234567890

8 POINT SELF SPACING NO 48½

Unit of measure, 9 to Pica

WHEN, in the course of human events, it becomes necessary for one people to dissolve the political bands which have connected them with another, and to assume, among the powers of the earth, the separate and equal station to which the laws of nature and of nature's God entitle them, a decent respect to the opinions of mankind requires that they should declare the causes which impel them to the separation. We hold these truths to be self-evident, that all men are created equal; that they are endowed by their Creator with certain unalienable rights; that among these, are life, liberty, and the pursuit of happiness. That, to secure these rights, governments are instituted among men, deriving their just powers from the consent of the governed; that, whenever any form of government becomes destructive of these ends, it is the right of the people to alter or to abolish it, and to institute a new government, laying its foundation on such principles, and organizing its powers in such form, as to them shall seem most likely to effect their safety and happiness. Prudence, indeed, will dictate that governments long established, should not be changed for light and transient causes; and, accordingly, all experience hath shown, that mankind are more disposed to suffer, while evils are sufferable, than to right themselves by abolishing the forms to which they are accustomed. But, when a long train of abuses and usurpations, pursuing invariably the same object, evinces a design to reduce them under absolute despotism, it is their right

Lower case a to z, 15½ ems

ABCDEFGHIJKLMNOPQRSTUVWXYZ
1234567890

9 POINT SELF SPACING NO 32½

Unit of measure, 9 to Pica

WHEN, in the course of human events, it becomes necessary for one people to dissolve the political bands which have connected them with another, and to assume, among the powers of the earth, the separate and equal station to which the laws of nature and of nature's God entitle them, a decent respect to the opinions of mankind requires that they should declare the causes which impel them to the separation. We hold these truths to be self-evident, that all men are created equal; that they are endowed by their Creator with certain unalienable rights; that among these, are life, liberty, and the pursuit of happiness. That, to secure these rights, governments are instituted among men, deriving their just powers from the consent of the governed; that, whenever any form of government becomes destructive of these ends, it is the right of the people to alter or to abolish it, and to institute a new government, laying its foundation on such principles, and organizing its powers in such form, as to them shall seem most likely to effect their safety and happiness. Prudence, indeed, will dictate that governments long established, should not be changed for light and *transient causes*; and, *accordingly, all experience hath shown, that mankind are more disposed to suffer, while evils are suffer-*

Lower case a to z, 13¾ ems

ABCDEFGHIJKLMNOPQRSTUVWXYZ
1234567890

10 POINT SELF SPACING NO 17½

Unit of measure, 8 to Pica

WHEN, in the course of human events, it becomes necessary for one people to dissolve the political bands which have connected them with another, and to assume, among the powers of the earth, the separate and equal station to which the laws of nature and of nature's God entitle them, a decent respect to the opinions of mankind requires that they should declare the causes which impel them to the separation. We hold these truths to be self-evident, that all men are created equal; that they are endowed by their Creator with certain unalienable rights; that among these, are life, liberty, and the pursuit of happiness. That, to secure these rights, governments are instituted among men, deriving their just powers from the consent of the governed; that, whenever any form of government becomes destructive of these ends, it is the right of the people to alter or to abolish it, and to institute a new government, laying its *foundation on such principles, and organizing its powers in such form, as to them shall seem most likely to effect*

Lower case a to z, 14 ems

ABCDEFGHIJKLMNOPQRSTUVWXYZ
1234567890

11 POINT SELF SPACING NO 21½

Unit of measure, 7 to Pica

WHEN, in the course of human events, it becomes necessary for one people to dissolve the political bands which have connected them with another, and to assume, among the powers of the earth, the separate and equal station to which the laws of nature and of nature's God entitle them, a decent respect to the opinions of mankind requires that they should declare the causes which impel them to the separation. We hold these truths to be self-evident, that all men are created equal; that they are endowed by their Creator with certain unalienable rights; that among these, are life, liberty, and the pursuit of happiness. That, to secure these rights, governments are instituted among men, deriving their just powers from the *consent of the governed; that, whenever a form of government becomes destructive of these ends*

Lower case a to z, 14½ ems

ABCDEFGHIJKLMNOPQRSTUVWXYZ
1234567890

12 POINT SELF SPACING NO 31½

Unit of measure, 7 to Pica

WHEN, in the course of human events, it becomes necessary for one people to dissolve the political bands which have connected them with another, and to assume, among the powers of the earth, the separate and equal station to which the laws of nature and of nature's God entitle them, a decent respect to the opinions of mankind requires that they should declare the causes which impel them to the separation. We hold these truths to be self-evident, that all men are created equal; that they are endowed by their Creator with certain unalienable rights; that among these, are life, liberty, and the pursuit of happiness; that, to secure these rights, governments are instituted among men, *deriving their just powers from the consent of the governed; that, whenever a form*

Lower case a to z, 13¼ ems

ABCDEFGHIJKLMNOPQRSTUVWXYZ
1234567890

SELF SPACING OLD STYLE ROMANS

For description of Self Spacing Type see pages 128 and 129

6 POINT SELF SPACING OLD STYLE NO 30

Unit of measure, 12 to Pica

WHEN, in the course of human events, it becomes necessary for one people to dissolve the political bands which have connected them with another, and to assume, among the powers of the earth, the separate and equal station to which the laws of nature and of nature's God entitle them, a decent respect to the opinions of mankind requires that they should declare the causes which impel them to the separation. We hold these truths to be self-evident, that all men are created equal; that they are endowed by their Creator with certain unalienable rights; that among these, are life, liberty, and the pursuit of happiness. That, to secure these rights, governments are instituted among men, deriving their just powers from the consent of the governed; that, whenever any form of government becomes destructive of these ends, it is the right of the people to alter or to abolish it, and to institute a new government, laying its foundation on such principles, and organizing its powers in such form, as to them shall seem most likely to effect their safety and happiness. Prudence, indeed, will dictate that governments long established, should not be changed for light and transient causes; and, accordingly, all experience hath shown, that mankind are more disposed to suffer, while evils are sufferable, than to right themselves by abolishing the forms to which they are accustomed. But, when

Lower case a to z, 15½ ems

ABCDEFGHIJKLMNPOQRSTUVWXYZ

1234567890

6 POINT SELF SPACING OLD STYLE NO 27

Unit of measure, 11 to Pica

WHEN, in the course of human events, it becomes necessary for one people to dissolve the political bands which have connected them with another, and to assume, among the powers of the earth, the separate and equal station to which the laws of nature and of nature's God entitle them, a decent respect to the opinions of mankind requires that they declare the causes which impel them to the separation. We hold these truths to be self-evident, that all men are created equal; that they are endowed by their Creator with certain unalienable rights; that among these, are life, liberty, and the pursuit of happiness. That, to secure these rights, governments are instituted among men, deriving their just powers from the consent of the governed; that, whenever any form of government becomes destructive of these ends, it is the right of the people to alter or to abolish it, and to institute a new government, laying its foundation on such principles, and organizing its powers in such form, as to them shall seem most likely to effect their safety and happiness. Prudence, indeed, will dictate that governments long established, should not be changed for light and transient causes; and, accordingly, all experience hath shown, that mankind are more disposed to suffer, while evils are sufferable,

Lower case a to z, 17 ems

ABCDEFGHIJKLMNPOQRSTUVWXYZ

1234567890

8 POINT SELF SPACING OLD STYLE NO 22

Unit of measure, 10 to Pica

WHEN, in the course of human events, it becomes necessary for one people to dissolve the political bands which have connected them with another, and to assume, among the powers of the earth, the separate and equal station to which the laws of nature and of nature's God entitle them, a decent respect to the opinions of mankind requires that they should declare the causes which impel them to the separation. We hold these truths to be self-evident, that all men are created equal; that they are endowed by their Creator with certain unalienable rights; that among these, are life, liberty, and the pursuit of happiness. That, to secure these rights, governments are instituted among men, deriving their just powers from the consent of the governed; that, whenever any form of government becomes destructive of these ends, it is the right of the people to alter or to abolish it, and

Lower case a to z, 14½ ems

ABCDEFGHIJKLMNPOQRSTUVWXYZ

1234567890

9 POINT SELF SPACING OLD STYLE NO 28

Unit of measure, 9 to Pica

WHEN, in the course of human events, it becomes necessary for one people to dissolve the political bands which have connected them with another, and to assume, among the powers of the earth, the separate and equal station to which the laws of nature and of nature's God entitle them, a decent respect to the opinions of mankind requires that they should declare the causes which impel them to the separation. We hold these truths to be self-evident, that all men are created equal; that they are endowed by their Creator with certain unalienable rights; that among these, are life, liberty, and the pursuit of *happiness*. *That, to secure these rights, governments are instituted among men, deriving their just powers from the consent*

Lower case a to z, 13 $\frac{3}{4}$ ems

ABCDEFGHIJKLMN OPQRSTUVWXYZ
1234567890

10 POINT SELF SPACING OLD STYLE NO 29

Unit of measure, 9 to Pica

WHEN, in the course of human events, it becomes necessary for one people to dissolve the political bands which have connected them with another, and to assume, among the powers of the earth, the separate and equal station to which the laws of nature and of nature's God entitle them, a decent respect to the opinions of mankind requires that they should declare the causes which impel them to the separation. We hold these truths to be self-evident, that all men are created equal; that they are endowed by their Creator with certain unalienable rights; *that among these, are life, liberty, and the pursuit of happiness*. *That, to secure these rights, governments are in-*

Lower case a to z, 12 $\frac{3}{8}$ ems

ABCDEFGHIJKLMN OPQRSTUVWXYZ
1234567890

10 POINT SELF SPACING OLD STYLE NO 24

Unit of measure, 8 to Pica

WHEN, in the course of human events, it becomes necessary for one people to dissolve the political bands which have connected them with another, and to assume, among the powers of the earth, the separate and equal station to which the laws of nature and of nature's God entitle them, a decent respect to the opinions of mankind requires that they should declare the causes which impel them to the separation. We hold these truths to be self-evident, that all men are created equal; *that they are endowed by their Creator with certain unalienable rights; that among these, are life, liberty,*

Lower case a to z, 14 ems

ABCDEFGHIJKLMN OPQRSTUVWXYZ
1234567890

11 POINT SELF SPACING OLD STYLE NO 25

Unit of measure, 8 to Pica

WHEN, in the course of human events, it becomes necessary for one people to dissolve the political bands which have connected them with another, and to assume, among the powers of the earth, the separate and equal station to which the laws of nature and of nature's God entitle them, a decent respect to the opinions of mankind requires that they should declare the causes which impel them to the separation. We hold these truths to be self-evident, that all men are created equal; that they are endowed by their Creator with certain unalienable rights; that among these, are life, liberty, and the pursuit of happiness. That, to secure these rights, governments are instituted among men, deriving their just powers from the consent of the governed; that, whenever any form of government becomes *destructive of these ends, it is the right of the people to alter or to abolish it, and to institute a new govern-*

Lower case a to z, 12 $\frac{2}{3}$ ems

ABCDEFGHIJKLMNOPQRSTUVWXYZ
1234567890

12 POINT SELF SPACING OLD STYLE NO 26

Unit of measure, 7 to Pica

WHEN, in the course of human events, it becomes necessary for one people to dissolve the political bands which have connected them with another, and to assume, among the powers of the earth, the separate and equal station to which the laws of nature and of nature's God entitle them, a decent respect to the opinions of mankind requires that they should declare the causes which impel them to the separation. We hold these truths to be self-evident, that all men are created equal; that they are endowed by their Creator with certain unalienable rights; that among these, are life, liberty, and the pursuit of happiness. That, to secure these rights, governments are instituted *among men, deriving their just powers from the consent of the governed; that, whenever a form*

Lower case a to z, 13 $\frac{1}{4}$ ems

ABCDEFGHIJKLMNOPQRSTUVWXYZ
1234567890

SELF SPACING OLD STYLE ITALIC

6 POINT SELF SPACING OLD STYLE ITALIC NO 27

CIRCULAR FONT \$7 00

The common widths of book pages, miscellaneous jobs and newspaper columns are some number of Pica ems, therefore the Pica em is taken as the basis for Self Spacing type. The thinnest space in all fonts is some exact fraction of a Pica, and this fraction of Pica is called the unit of measure. All characters, spaces and quads in the font are made some exact multiple of this unit in width, so that the sizes of all faces will work perfectly together in the regular labor-saving measures. This unit of measure may be one-sixth, one-seventh, one-eighth, one-ninth, etc., of a Pica em, as may be desired, to

8 POINT SELF SPACING OLD STYLE ITALIC NO 22

CIRCULAR FONT \$5 40

The common widths of book pages, miscellaneous jobs and newspaper columns are some number of Pica ems, therefore the Pica em is taken as the basis for Self Spacing type. The thinnest space in all fonts is some exact fraction of a Pica, and this fraction of Pica is called the unit of measure. All characters, spaces and quads in the font are made some exact multiple of this unit in width, so that the sizes of all

9 POINT SELF SPACING OLD STYLE ITALIC NO 28

CIRCULAR FONT \$4 80

The common widths of book pages, miscellaneous jobs and newspaper columns are some number of Pica ems, therefore the Pica em is taken as the basis for Self Spacing type. The thinnest space in all fonts is some exact fraction of a Pica, and this fraction of Pica is called the unit of measure. All characters, spaces and quads in the font are made some exact multiple of

10 POINT SELF SPACING OLD STYLE ITALIC NO 24

CIRCULAR FONT \$4 45

The common widths of book pages, miscellaneous jobs and newspaper columns are some number of Pica ems, therefore the Pica em is taken as the basis for Self Spacing type. The thinnest space in all fonts is some exact fraction of a Pica, and this fraction of Pica is called the

11 POINT SELF SPACING OLD STYLE ITALIC NO 25

CIRCULAR FONT \$4 20

The common widths of book pages, miscellaneous jobs and newspaper columns are some number of Pica ems, therefore the Pica em is taken as the basis for Self Spacing type. The thinnest space in all fonts is some exact fraction of a Pica, and this fraction of Pica is called the

12 POINT SELF SPACING OLD STYLE ITALIC NO 26

CIRCULAR FONT \$3 95

The common widths of book pages, miscellaneous jobs and newspaper columns are some number of Pica ems, therefore the Pica em is taken as the basis for Self Spacing type. The thinnest space in all fonts is some exact fraction of a

Spaces and Quads are included with each font

SELF SPACING OLD STYLE BOLD

Designed especially to work with Self Spacing Old Style Romans shown on pages 136 to 138

6 POINT

Unit of measure, 12 to Pica

30 A 50 a \$3 00

THIS SERIES of Old Style Bold was cut after many inquiries for a Job Face that could be used with Self Spacing to emphasize certain words. All sizes shown on this page will line and justify with the corresponding sizes of our Old Style Self Spacing Series. Repeated experiments have shown that the average compositor gains

This Series of Old Style Bold was cut after many inquiries for a Job Face that could be used with Self Spacing to emphasize certain words. All

8 POINT

Unit of measure, 10 to Pica

30 A 50 a \$3 30

THIS SERIES of Old Style Bold was cut after many inquiries for a Job Face that could be used with Self Spacing to emphasize certain words. All sizes shown on this page will line and justify with the corresponding sizes of our Old Style Self Spacing Series. Repeated experiments have shown that the average compositor gains about 25 per cent. with no trouble in justification whatever.

9 POINT

Unit of measure, 9 to Pica

28 A 45 a \$3 35

THIS SERIES of Old Style Bold was cut after many inquiries for a Job Face that could be used with Self Spacing to emphasize certain words. All sizes shown above will line and justify with the corresponding sizes of our Old Style Self Spacing Series. Repeated experiments with Self Spacing Type have shown that the average compositor gains about 25 per

10 POINT

Unit of measure, 8 to Pica

25 A 40 a \$3 50

THIS SERIES of Old Style Bold was cut after many inquiries for a Job Face that could be used with Self Spacing to emphasize certain words. All sizes shown on this page will line and justify with the corresponding sizes of all our Old Style Self Spacing Series. Repeated experiments with Self Spacing Type have shown

12 POINT

Unit of measure, 7 to Pica

25 A 38 a \$4 00

THIS SERIES of Old Style Bold was cut after many inquiries for a Job Face that could be used with Self Spacing to emphasize certain words. All sizes shown on this page will line and justify with the corresponding sizes of our Old Style Self Spacing Series. Repeated experiments with

Circular Letter

*An Exhibition of Serviceable Type Styles
admirably suited for the printing of
Circulars, Announcements,
Invitations, etc.*



STANDARD TYPEWRITER

12 POINT

100 a \$5 95 20 A 100 a \$7 45

Through the courtesy of the manufacturers of the Remington Standard Type-Writer, ~~we~~ we are permitted to present in type (from facsimile impressions furnished by them) ~~and~~ an exact counterpart of the type-writing of their most popular machine.

AMERICAN TYPEWRITER

10 POINT

85 a \$3 50 18 A 85 a \$5 00

WARRANT FOR MALICIOUS MISCHIEF AND BREACH OF PEACE

To Any Constable in the Township.—You are hereby commanded to take the body of Ranger Nocturne, and bring him before Magistrate Stern Justice, to answer the Commonwealth upon the charge, founded on an oath of Snuffitt Chuansmoak, of having broken the nose of one wooden Indian, which had been set up by the plaintiff to attract customers. Witness the said Stern Justice, who has set hereunto his hand and seal, on the 14th day of September, 1927.

Its adaptability for printing circulars is

10 POINT No 2

85 a \$3 50 18 A 85 a \$5 00

At the last meeting of the association resolutions were passed requesting all lady-members to refrain, when visiting places of amusement, from wearing bonnets and hats decorated with high-soaring plumage or flowers. The male fraternity has at last made a successful protest, and the lawmakers have decided that all headgear which will obstruct the view must be

Spaces are included with each font of Typewriter

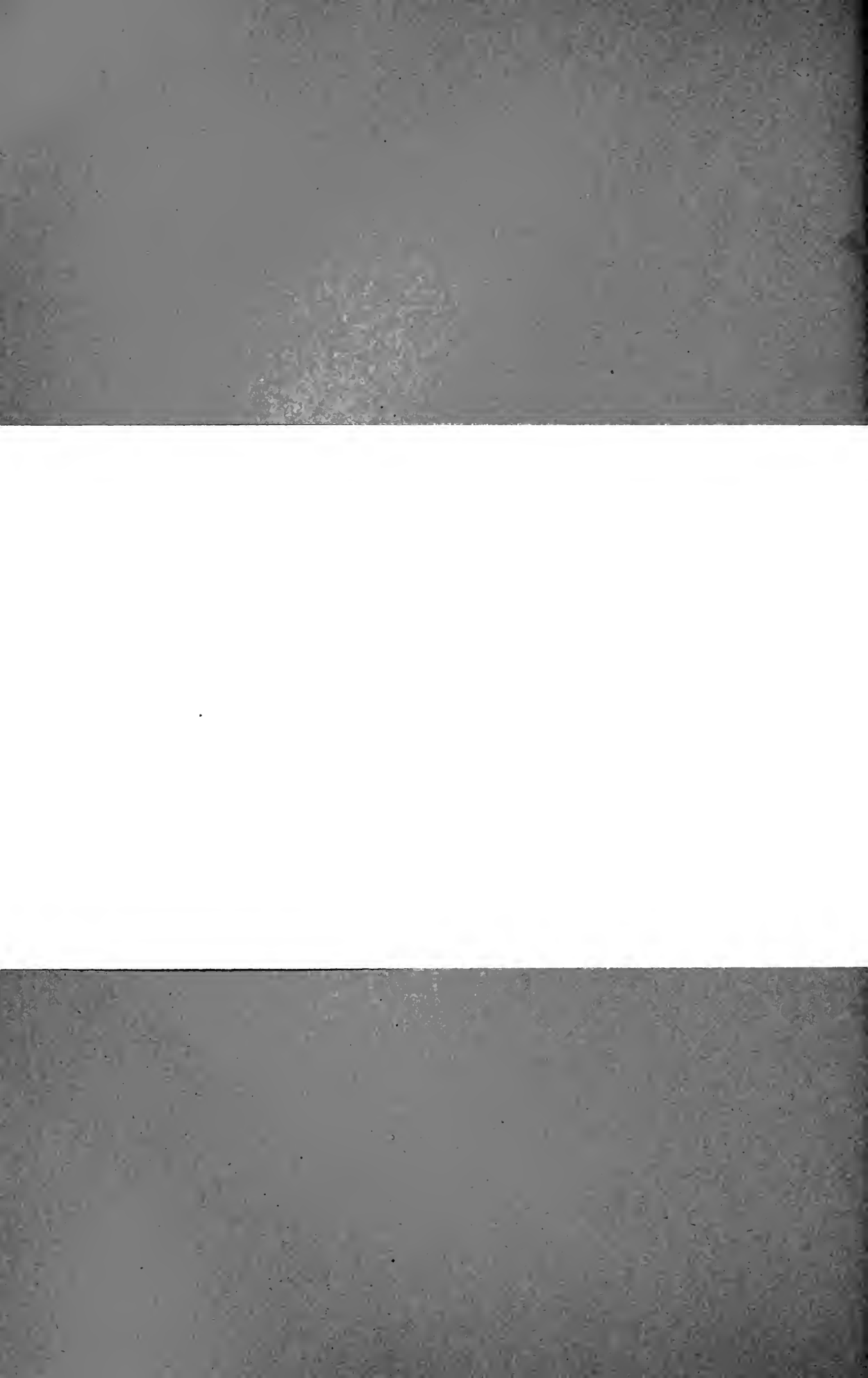

STANDARD TYPEWRITER

12 POINT

100 a \$5 95 20 A 100 a \$7 45

Through the courtesy of the manufacturers of the Remington Standard Type-Writer, ~~a~~ we are permitted to present in type (from facsimile impressions furnished by them) ~~and~~ an exact counterpart of the type-writing of their most popular machine.

As the above Type-Writer has the approval of business people in general, and as the number in use far exceeds ~~the~~ those of any other make, the printing craft will doubtless avail itself of the style of ~~the~~ type herewith presented as being the latest and

TYPEWRITER SERIES

14 POINT NO 2

75 a \$5 30 15 A 75 a \$7 50

In this Type-Writer series each character is cast on en set, and for spaces the common en quad is used. Job men in general favor this idea, and its popularity is increasing. Its adaptability for printing circulars is

10 POINT NO 2

85 a \$3 50 18 A 85 a \$5 00

At the last meeting of the association resolutions were passed requesting all lady-members to refrain, when visiting places of amusement, from wearing bonnets and hats decorated with high-soaring plumage or flowers. The male fraternity has at last made a successful protest, and the lawmakers have decided that all headgear which will obstruct the view must be

Spaces are included with each font of Typewriter

REMINGTON STANDARD

12 POINT

110 a \$5 25 20 A 110 a \$7 25

Mayew, Lose and Moan

Dear Sirs--In answer to your letter of April 3 concerning Trees. Knowing all about such things we have prepared a small booklet entitled Trees--How to Grow Them--which will be sent for the small sum of 14 cents to all farm-houses east of Timbuctoo and north of Easton. The edition contains fine engravings and wood-cuts carved on the wood of trees raised through our efforts, and is printed on hand-made paper.

Respectfully

The Hawaiian Nurseries

SMITH-PREMIER TYPEWRITER

12 POINT

108 a \$4 10 20 A 108 a \$7 50

SALE OF VALUABLE REAL ESTATE.

Whereas, John Smith and Samantha Smith, his wife, by their deed of Trust, dated May 23d, 1890, and duly recorded in the office of the Recorder of Deeds of the City of St. Louis, State of Missouri, in book 966, page 7, conveyed to the undersigned, as trustee, following described real estate, situate in the City of St. Louis, State of Missouri, to-wit: Lot thirty-five (35) of Claggett's second division, and in block number 4468. Said lot having a front of twenty-four (24) feet on the west side of Eagon street, by a depth westwardly of one hundred and twenty

Spaces are included with each font of Typewriter

YOST TYPEWRITER

12 POINT

90 a \$4 65 20 A 90 a \$6 50

We beg to call your attention to this exact imitation of Yost Typewriter Type which was made especially for "imitation" work. No expense has been spared to make this type the most perfect imitation ever placed on the market, and all engaged in doing this class of work should send their

10 POINT

90 a \$4 65 20 A 90 a \$6 75

Everybody seems to think that as soon as they can afford it they must go to England or Europe and "be in style." If they go abroad for the scenery, or for a change of climate, they might just as well have stayed home. For within the bounds of the United States may be found places that would put

EARLE TYPEWRITER

12 POINT

108 a \$4 10 20 A 108 a \$7 50

The great usefulness of this face as a type with which circulars could be made to resemble genuine correspondence, and secure them attention, was apparent at first glance, and an immense sale followed its introduction. It is of a plain and neat character, and at the same time a good wearer, which accounts for

Spaces are included with each font of Typewriter

STENOGRAF

12 POINT

60 a \$2 85 20 A 60 a \$4 65

Since the printing of the call for the regular meeting, a petition has been received from the unemployed members of our Union asking that some action be taken at the next meeting for their temporary relief. This is an important matter and calls for the careful consideration of the membership, and a

CALIGRAPH

12 POINT NO 4

70 A \$4 65 15 A 70 a \$6 20

Dear Sir:-The advanced cost of raw materials compels us to withdraw all outstanding quotations and to notify customers that during the unsettled condition of the market all prices will be subject to change without notice. Desiring your continued favors, we wish to assure you

TYPEWRITER

12 POINT

108 a \$4 10 20 A 108 a \$7 50

Much could be said about the advances made in the contrivances of warfare: from the bows and arrows of the Indians and the swords and armor of bygone days to the modern cannon and repeating rifles of to-day with their smokeless powder; from the big, clumsy galley to the modern warship with its guns and steel

Spaces are included with each font of Typewriter

LAW ITALIC No 120

12 POINT

Card Font 9 A 25 a \$2 10
Circular Font 18 A 100 a \$6 60*THE TIME STANDARDS OF THE WORLD
LESSONS IN PHYSICAL SCIENCE*

The observatory clock having been once set right by observations of the sky, its error can be re-determined every few days quite easily. In this way even the small irregularities of its nearly perfect mechanism, in fact, can be prevented from collecting until they might come to a harmful size. But we obtain thus only a correct standard of time within the observatory itself. Cost about \$91

8 POINT

Card Font 16 A 50 a \$2 50
Circular Font 32 A 200a \$8 05*SIGNALS SENT AT NOON
BY ELECTRIC WIRES*

Every day at noon precisely an electric signal is sent out by the United States Naval Observatory in Washington. This signal is regulated by the clock of the observatory.

1234567890

10 POINT

Card Font 12 A 35 a \$2 30
Circular Font 24 A 140a \$7 40*SIGNAL RECEIVED AT CENTRAL NEW YORK
OFFICE OF TELEGRAPH COMPANY*

It is used to keep correct a very fine clock, which may be called the time standard of the telegraph company. This clock in turn has automatic electric connections, by means of which it is made to send out signals over what are called "time wires," that go all over the city. Jewelers and others who desire correct time may arrange to have a small electric sounder in their offices connected with the time wires. The ticks of the clocks are automatically repeated in stores and jewelers shops 1234

6 POINT

Card Font 16 A 50 a \$2 00
Circular Font 32 A 200a \$6 70*THE SUN PASSES ITS MERIDIAN
AT TWELVE O'CLOCK*

The sun, as we know, rises each morning in the east, slowly goes up higher and higher in the sky, and at last begins to descend again to the west. But it is clear that as the sun travels from east to west it must pass over us

1234567890

JENSON ITALIC

18 POINT

10 A 25 a \$4 00

THIS SERIES AS A DISPLAY LETTER is a novelty. It is of a distinct and striking character, and is made to the same line as the Jenson Old Style. Its usefulness as a companion letter will be appreciated by printers

6 POINT

20 A 50 a \$2 50

EVERYTHING FOR THE PRINTER, FROM A PAIR OF TWEEZERS TO A perfecting press (to say nothing of type) can be delivered on the shortest notice by any Branch House of the American Type Founders' Company. These Houses are all conveniently located throughout the United States for the benefit of the trade and to facilitate the work of supplying the demands made upon us by an appreciative and increasing patronage. Therefore, by placing your orders with the House nearest your place of business you will insure promptness.

A printing office that is supplied with the products of this Company is worth far more for use or sale than one made up from productions of incomplete type foundries. This Company leads in the production of popular type styles as the number of them used in standard magazines will testify. Many of its designs are imitated, but its originals are never equalled nor even approached. Unique types for all classes of work are being constantly brought out by this Company

10 POINT

20 A 45 a \$3 00

THE TYPE TURNED OUT BY THIS COMPANY CONCEDED BY EXPERT printers to outrank that of all competitors in beauty of design, style of finish, and in its wearing qualities. These cardinal features are, in themselves, sufficient to recommend them to the army of purchasing printers and magazine publishers as a saving investment

8 POINT

20 A 50 a \$2 75

NOW TO THE POINT THAT PINCHES—THE SPENDING OF MONEY—WHICH HAS BEEN subject to discussion for time immemorial. When figuring on the cost of new type do you regard it as unnecessary expense or in the light of a good investment to buy the best? If as an investment, suppose a first-class style of type cost you a little more than a less attractive design, but the returns are double, which would be the most profitable?

12 POINT

18 A 40 a \$3 25

“AD” WRITERS WHO ALWAYS COMMENDED THE use of old style letters to their clientele will recognize in Jenson Italic a monotony-breaking substitute, and the public will see it and be impressively attracted by advertisements set in this modest and character-giving letter. The aim of writers of advertisements is naturally to attract business to themselves. This can be done by attracting readers to those who advertise

For a complete showing of this series, see pages 234-239

VENETIAN SERIES

18 POINT NO 122

Card Font 10 A 50 a \$8 15
Circular Font 20 A 100 a \$12 30

The Invention of Printing has always been recognized by educated men as a subject of importance: there is no mechanical art, nor are there any of the fine arts, about whose early history so many books have been rewritten, the 45

18 POINT NO 121

Card Font 10 A 50 a \$8 00
Circular Font 20 A 100 a \$12 00

The Invention of Printing has always been recognized by educated men as a subject of importance: there is no mechanical art, nor are there any of the fine arts, about whose early history so many books have been rewritten, the 27

12 POINT NO 122

Card Font 10 A 50 a \$3 25
Circular Font 20 A 100 a \$6 50

The Invention of Printing has always been recognized by educated men as a subject of importance: there is no mechanical art, nor are there any of the fine arts, about whose early history so many books have been written. There is an unusual degree of obscurity about the origin of the first printed books and the lives and works of early 67

12 POINT NO 121

Card Font 10 A 50 a \$3 05
Circular Font 20 A 100 a \$6 10

The Invention of Printing has always been recognized by educated men as a subject of importance: there is no mechanical art, nor are 89

10 POINT NO 120

Card Font 12 A 70 a \$4 05
Circular Font 24 A 140 a \$8 10

The Invention of Printing has always been recognized by the educated men as a subject of great importance: there is no mechanical art, nor are there any of the fine arts, about whose history 34

FRENCH OLD STYLE No 2 ITALIC

10 POINT

20 A 50 a \$3 00

In the earlier years of his life the parents of Horace E. Walker moved to Claremont, N. H., thence to Brooklyn, N. Y., the father returning to that place from a short stay in California. From thence the family returned to Claremont, at which place the author's poetic labors have since been performed. Come of poor parents his educational advantages were small, he not having attended school since he was about sixteen years of age; and his best work was mostly composed in a cotton factory while tending the Slasher so often referred to in his poems. But not till after he had reached the age of twenty-four did he attempt poetry. And strange enough, the "Lady's Cabinet of Polite Literature" was the star-book of his poetic career, which having been published in 1808, was enchanting to the view.

ROBERT BURNS
AND HIS
HIGHLAND MARY

14 POINT ELZEVIR ITALIC

16 A 36 a \$3 90

On August 9, 1852, a child was born at Charlestown, N. H., who, Burns-like, was to eke out a precarious and uncertain poetic existence in the coming years. You see the little gable-roofed house where he was born at the foot of the long hill, with its ancient moss-covered watering trough, just on the outskirts of the historic town. It stands there to-day in its unassuming simplicity, with but slight marks of age, though nearly half a century has passed since its birth there.

THE LADY
OF DARDALE

FRENCH OLD STYLE No 2 ITALIC

8 POINT

We now come to the commencement of the third period of Grecian history, at which time the Grecians became intermixed with the Persians in their late history. Darius, son of Hystaspes, being in possession of the Persian throne, resolved to conquer the Greeks, and bring their territory under his immediate control. He therefore sent his army, under the command of his most able officers, into Greece, and the Persians were so sure of success that they carried

6 POINT

ARISTIDES WAS A STRONG CONTRAST TO THEMISTOCLES, and appeared everywhere to oppose his corrupt principles. He was a man of true and noble character, straightforward and upright in all his deportment. He would not sacrifice principle to favor his best friend; and because of these excellent traits of character he was called Aristides the Just. Aristides was banished from Greece at one time, through the influence of Themistocles, who wanted to be rid of his constant reproof, and when the people came to vote for his banishment, as was customary, the name of the accused was written upon a shell. A peasant who could not write, and who did not know Aristides personally, approached a stranger and requested that he would write the name of Aristides upon his shell; when the stranger asked: "Why do you vote against him; has he done you any wrong, that you are anxious to condemn him?" "No," replied the peasant, "I do not even know him; but I am tired and angry with hearing him called 'The Just.'" Then that stranger took the shell, and wrote the name Aristides upon it, and quietly and courteously returned it to the peasant. That stranger was Aristides himself.

wealth and considerable influence, which he used for that purpose. He favored those who would favor him in return; like some men of to-day. About election time there are often those who are ready to grant favors in order to secure the desired object. Their money is made to flow freely, and their affability is most remarkable. This was characteristic of Themistocles.

24 A 60 a \$2 75

THE
WORLD'S
GREAT
EMPIRES

marble with them for the purpose of erecting a monument to their glory, as conquerors, when the Grecians should be defeated. The celebrated battle of Marathon followed, when the Persian soldiers came in contact with such men as Themistocles, Aristides, Miltiades, and many others of considerable note, distinguished for their courage and valor—who were prepared to resist them, and to defend their country. It is well to notice the character of these prominent men as they come before us in this capacity, and, in doing so, we shall see that they were not unlike men of our own times. The two first mentioned, Themistocles and Aristides, were a perfect contrast in their principles of life.

12 POINT

16 A 40 a \$3 50

Themistocles, though having great ability, was always working especially for his individual interest. He loved office, and was ready to do anything that would insure his election to an official position. He had great

THE
ARMY
OF
VALOR

123456

CUSHING SERIES

12 POINT

14 A 8 A 36 a \$5 00

EXHIBITION OF SCIENCE CLUB BOOK PAPERS.

1898

PARLORS OPEN
ENTIRE MONTH
OF APRIL, AND
THE PUBLIC IS
INVITED DAILY.

Can you afford to miss an opportunity for the preservation of your eyesight if it is presented to you? Many years since men of study, bookkeepers, clerks, and the like, were unable to obtain any relief from the strain upon their eyes caused by the constant use of paper made in an unscientific manner. After many years of experiment and study we have made a paper in which this is eliminated.

10 POINT

16 A 10 A 40 a \$4 50

NEW SHADES IN MY LADY'S STATIONERY FOR COUNTRY AND SEASHORE EFFUSIONS.

One of the most attractive of the new shades has been called Antique Bronze. It is a very fair imitation of some verdigris-covered bronze of ancient statues and coins. Among the new shades of gray are Pearl Gray and the Gray Musketeer, both of which are neutral in tone and in contrast with most every variety of color in writing inks. Mauve and a sap green called Empire seem to be in favor, although neither of these are as attractive as the names might indicate. In our store will be found writing material of every description

FRANKLIN STATIONERY COMPANY
WASHINGTON INSURANCE ARCADE
SOUTH NORWALK, WEST VIRGINIA

8 POINT

20 A 12 A 44 a \$4 00

HIGHER IN QUALITY AND LOWER IN PRICE SIX DAYS IN THE WEEK.

Many business houses seem to think a good reputation is something that their customers should pay a good price for. As soon as an enviable distinction is acquired, the price of goods is advanced and the cream is skimmed as long as it rises. Our goods are recognized as the standard of the world, and yet they were never sold so cheap as the present time.

SOUTH AMOSKEAG MANUFACTURING COMPANY
BROWN AVENUE, HYDE PARK, NORTH DAKOTA

6 POINT

20 A 12 A 50 a \$3 50

AUTOMATIC FLYING MACHINE COMPANY ORGANIZED APRIL 1, 1900

These machines embody the results of thirteen unlucky days of foolishness and inexperience. In their construction the highest grade of gold bricks is used for the foundation, and inflation is of that quality of verdure which has gained for our house a reputation second to none in the country, otherwise known as the hay-seed district. Drop in and

SEE THEM SOAR, THEN DROP OUT AND
FEEL THE SORENESS

For a complete showing of this series, see pages 414 and 415

CUSHING ITALIC

12 POINT

20 A 50 a \$3 94

*EMBRACING OPPORTUNITIES, TAKING
ADVANTAGE OF THE SITUATION, OR**Timing your action to the exact moment when all indications are
propitious, is the acme of good business judgment.**How many possess these qualities?**1 2 3 4 5 6 7 8 9 0*

10 POINT

28 A 80 a \$3 80

*MEN, LIKE PICTURES, MAY BE PLACED IN
AN OBSCURE OR UNFAVORABLE LIGHT!**There is a secret propensity in human nature, from generation to generation, in
the blockheads of one age to admire those of another.**Is lying a "clever" faculty?*

8 POINT

28 A 80 a \$3 00

*THE OLD CANTEEN**I tell you, Jim, it ain't no use,
A soldier can't forget,
Those bloody scenes are just as fresh
As on the day we met;
But all the relics of the war,
The broken sword, I ween,
E'en knapsack old, there is none like
The dear old tin canteen.**You recollect as well as I
The hunger and the thirst,
The mad career of horse and men,
Where rebel shells had burst;
But after all, you gray old vet.,
The best remembered scene -
Was when we stole a chance to drink
From out the old canteen.*

6 POINT

28 A 80 a \$2 60

*THE OLD BRASS KNOCKER**Now, children dear, 't is the song of the knocker,
The old brass knocker of grandfather's days,
A sweet sad tale where harshly asunder
The household were torn in the prime of their Mays;
But turn to the picture now mellowed forever
By the gray hand of Time in his strange lapse of years,
And a home like your own so dear to your bosom,
May shine like a halo thro' the mist of your tears.**For a complete showing of this series, see pages 260 and 261*

SELF SPACING OLD STYLE ITALIC

12 POINT NO 26

CIRCULAR FONT \$3 95

UNSURPASSED RESULTS IN TYPE MANUFACTURE

The man who is satisfied with his attainments should be wrapped in the cerecloth of his self-conceit and laid away on a mummy shelf. His part is done: the world does not want him any longer. The artist, the printer, the type-founder who does not constantly try and add to his laurels, will become mummified, and fit to be laid away among the piles of things entirely forgotten. By dint of brain and hand we have reached the excelling point 29

8 POINT NO 22

CIRCULAR FONT \$5 40

THE STAMP OF APPROVAL PLACED ON OUR PRODUCT BY APPRECIATIVE TYPE FOLK

The popularity of Type is based on its effectiveness for the purpose intended, and effectiveness is the result of the study, skill, and artistic perception of the designer. Designers of good Type Faces are scarce. We look almost in vain to the decorative artist or the painter for aid in the art of making type, and the scarcity of talent in this line accounts for the fact that productions of competing founders are imitative. The American Type Founders' Company has a number of designers and expert critics such as were never before brought together in the history of letter founding. \$1234567890

10 POINT NO 24

CIRCULAR FONT \$4 45

IMPORTANT FACTS FOR THE PERUSAL OF PRINTERS

Our Type is designed better, is cut better, and is better made in every way, than any other Type. It pleases the general public that pays for printing; consequently, it is more valuable to the printer. It brings trade because it is fashionable and stylish. For these reasons it is used by all the leading printers, on all the leading magazines, and in all the great book-printing establishments. Our Jobbing Type outclasses everything in that line in design, mechanical accuracy, and wearing quality. The large variety of our Brass Rule faces enables us to satisfy 12345678

Spaces and Quads are included with each font

SELF SPACING OLD STYLE ITALIC

11 POINT NO 25

CIRCULAR FONT \$4 20

GREEK, HEBREW, RUSSIAN, ARMENIAN AND MUSIC TYPE

Greek Types are used wherever learning flourishes. This Company is the only type founding concern in this country with sufficient enterprise to make this kind of Type, and it is made in several styles and sizes. Whenever you see a book or a line printed in Greek, remember that the type was made by the most complete type founding concern in the world. Hebrew, Russian, Armenian and Music Type, are also among the many products of this Company. This Company not only makes the very best Music Type in America, but it has a greater variety of sizes 5980

6 POINT NO 27

CIRCULAR FONT \$7 00

THERE ARE GREAT OPPORTUNITIES FOR FINE PRINTING THE FIELD FOR THIS CLASS OF WORK GROWS

Fine printing is profitable, just as fine painting, fine writing, fine acting, and fine architecture are profitable. In no past period was superlative effort in all directions so well rewarded as in this. Fine printing is in demand by a rapidly increasing class of business men who will spend more liberally for printing in proportion as it rises above the level of a mechanic art, and is executed with brains, taste and refinement. What is fine printing? As well attempt a formula for producing masterpieces in any art as to define the limits of fine printing. The fine printer becomes such by study, by aptitude, and by good taste; his efforts vary in excellence, and only occasionally become masterpieces, these depending upon circumstances. The test of fine printing is in its endurance: if done a century ago, is it admirable to-day? if done to-day, will it be admired a decade hence?

9 POINT NO 28

CIRCULAR FONT \$4 80

A FEW SUGGESTIONS ON ADVERTISING THE PRINTING OFFICE

Printers are generally subject to just reproach because of their neglect of advertising. Business men in other lines of business who advertise are the best and most liberal customers of the printer, and their success should stimulate like enterprise among printers, especially as they can advertise at first cost. In our experience we never knew of a printer who failed to increase his business if he advertised persistently and with good judgment. A printer's advertising should emanate from his own office, should rise above the commonplace, should solicit business, should be original, and should state as clearly as possible the cost of similar booklets, circulars, blotters, etc. This style of advertising pays 26359

Spaces and Quads are included with each font

FLORENTINE OLD STYLE No 2

8 POINT 30 A 32 a \$2 75

AMERIGO VESPUCHI
& COMPANY

Vacation Tourists'
Agents

12 POINT

20 A 24 a \$3 75

AUTHENTIC DIRECTIONS CONCERNING
POPULAR ROUTES OF TRAVEL IN ALL
THE RICHEST COUNTRIES ON THE MAP

10 POINT

25 A 32 a \$3 25

AROUND the World in Eighteen Days is the title of an elegantly illustrated brochure now on the press, and soon to be published. Neither pains nor expense have been spared in making it helpful to travelers at home and abroad, and printers contemplating a vacation trip encircling the globe will find between the covers a mint of valuable information. Among the commendable features might be mentioned a time-table giving connections with railroads and steamers that will enable the voyageur to resume business at the old stand in eighteen days from the time of embarkation, and in this itinerary there is ample time allowance for the many side issues which combine to make the trip both profitable and pleasurable. A copy of the brochure will be mailed you within a few days, and further information can be had from

AMERIGO VESPUCHI & CO.

Pensacola, Florida

6 POINT 36 A 40 a \$2 50

OUR TRANS-CONTINENTAL
VACATION EXCURSIONISTS

Come from every walk of life
and from every section of the
country. They constitute our
very reliable reference bureau

*For a complete showing of this series,
see pages 342 and 343*

WAVERLY CIRCULAR

10 POINT

Card Font 12 A 24 a \$3 10
Circular Font 36 A 150 a \$13 85

CHEAP RATE

to the
GOLD FIELD
Offered by this
Company
\$190

12 POINT

Card Font 10 A 20 a \$3 00
Circular Font 30 A 140 a \$14 25

LATE REPORTS FROM THE
KLONDIKE FIELDS OF GOLD
DECEMBER THE 25TH, 1900

REPORTS from the Klondike show that the amount of gold in that region has not been over-estimated, and that the rush to that country has started in earnest. The collector of customs in Alaska has just arrived in Washington from Sitka. He thinks there will be a great rush for the gold fields next summer from all parts of the world. The Yukon is only open for navigation during July, August and September. All persons contemplating the voyage should correspond with the Klondike Navigation Company at once

8 POINT

Card Font 14 A 30 a \$3 00
Circular Font 40 A 160 a \$10 85

FINDING GOLD
IN ABUNDANCE

Send for Circular
giving the details
of a voyage to the
KLONDIKE

LOWEST TERMS
FAST STEAMER

STYLUS No 2

PATENTED

24 POINT

6 A 14 a \$5 00

Grand Autumnal Display
The Australian Tailoring Company
will Exhibit several Leading Styles
Wednesday, September 25th, 1894

18 POINT

8 A 20 a \$4 50

Our Ambition is to Give Satisfaction
For the convenience of buyers who live out of
town we have issued a Descriptive Catalogue,
magnificently embellished with Photogravures,
which we send to any address upon application

12 POINT

12 A 32 a \$4 00

Dress Goods, Millinery, Laces and Curtains

Our several departments are fully stocked with merchandise,
which is matchless in quality, style, variety and cheapness.
Prospective purchasers should find their way to our reliable
establishment, and examine our stock and prices. We have
an excellent corps of salesladies who are always gladsome,
and who deem it a pleasure to display our goods to customers

STYLUS SERIES

PATENTED

24 POINT

6 A 14 a \$5 60

Swagger and Gasconade

*Inform the public that to-day they
start in business confident of success*

18 POINT

8 A 20 a \$5 05

Having Out our Wisdom Teeth

*We are satisfied that we have ability of very
high order, and ask you and your friends to
examine our goods, prices and correct methods*

12 POINT

12 A 32 a \$3 90

The Earthquake Snook us Nearly out of our Boots

*And our goods off the top shelves. The stock is uninjured; but
rather than rearrange it we will allow it to go at ninety-nine per
cent. discount. Come early and often, and take advantage of the
opportunity that offers itself to get one dollar's worth for a penny*

1 2 3 4 5 6 7 8 9 0

9 POINT

12 A 32 a \$2 70

The Almshouse Doors are Wide Open for our Reception

*We close our business career this morning with the well-wishes of the sheriff, an
immense stock of experience, some tattered clothes, no money, and many creditors;
but our Wisdom Teeth are still in good condition, and in the future we shall exercise
them on such alimentary substances as may be doled out to us by the authorities*

1 2 3 4 5 6 7 8 9 0

CIRCULAR ITALIC No 120

24 POINT

10 A 50 a \$6 10

The Invention of Printing has always been recognized by Educated Men as a subject of great importance: there is no mechanical art, nor are there any of 85

18 POINT

10 A 50 a \$4 65

The Invention of Printing has invariably been recognized by educated men as a subject of vast importance: there is no mechanical art, nor are there any of the fine arts, about whose early history so many books have been written and 42

12 POINT

18 A 100 a \$5 40

The Invention of Printing has always been recognized by educated men as a subject of importance: there is no mechanical art, nor are there any of the fine arts, about whose early history so many books have been written. The subject is as mysterious as it is inviting. There is an unusual degree of obscurity about the origin of 379

10 POINT

24 A 140 a \$5 95

The Invention of Printing has always been recognized by the educated man as a subject of great importance: there is no mechanical art, nor are there any of the fine arts, about whose early history so many books have been written. There 369

8 POINT

32 A 200 a \$6 35

The Invention of Printing has always been recognized by educated men as a subject of vast importance: there is no mechanical art, nor are there any of the fine arts, about whose early history so many books have been written. The subject is as mysterious as it is inviting. There is an unusual degree of obscurity about the origin of the first printed books and the lives and works of the 7348

CIRCULAR GOTHIC No 120

24 POINT

Card Font 10 A 20 a \$3 20
Circular Font 10 A 40 a \$4 90

EXCELLENT HOUSE ENTERTAINMENTS
Artistically Staged Dramatic Productions
King Richard and Sir Joseph Surface 48

18 POINT

Card Font 12 A 24 a \$2 65
Circular Font 12 A 48 a \$4 05

CLASSIFIED AND UNABRIDGED CATALOGUE
For Convenience of Buyers who live out of town
we have issued a Descriptive Catalogue which 52

12 POINT

Card Font 18 A 36 a \$2 45
Circular Font 18 A 108 a \$5 05

PERILS OF COLUMBUS ON HIS VOYAGE OF DISCOVERY TO
the Westward. Indications of approaching land became more
certain, and excited hopes in proportion. The birds began to
appear in flocks, making towards the Southwest. Colum-
bus, in imitation of Portuguese navigators who had 713

10 POINT

Card Font 24 A 48 a \$2 45
Circular Font 24 A 144 a \$5 15

WORKS OF FAMOUS AUTHORS
sunk in oblivion. Paradoxical as
it may seem, the chief causes of
the oblivion of books is no longer
their extinction, but the fond care
with which they are preserved 904

8 POINT

Card Font 24 A 48 a \$2 10
Circular Font 24 A 144 a \$4 40

SAILORS LOSE HEART AND DESIRE
Columbus to turn about and sail for Eu-
rope. Despair, impatience and unbounded
rage appeared in every countenance. All
sense of subordination was lost, and a
scene of confusion ensued. The officers
who had previously concurred with Co-
lumbus in opinion, and supported 8253

APOLLO SERIES

18 POINT

9 A 18 a \$4 00

ARTISANS TALENTS UNKNOWN
 Every day sends to their graves a number of obscure men, who have only remained such on account of their extreme timidity, which they have not been able to conquer \$65

12 POINT

12 A 28 a \$3 50

THE VAGABOND AND CONTEMPTIBLE ROGUE
 Beware of those who are homeless by choice. You have no hold on a human being whose affections are without a tap-root. The laws recognize this truth in the privileges which they confer upon the freeholder and the responsible citizen; and public opinion acknowledges it as a just decision, though seemingly harsh in its sweeping denunciation 42

10 POINT

14 A 32 a \$3 25

JOYFUL SPRING MONTHS
 I love to look on these young faces, and see the firstlings of a young man's beard, and the maidenly bloom blushing over the girl's fair cheek; I love to see the eyes beaming with joy and goodness, to see the unconscious joy of \$49

8 POINT

20 A 44 a \$3 00

TIME IS THE CRADLE OF DESTINY
 Time constantly flies, yet it overcomes all things by flight; and although it is the present ally, it will be the future conqueror of Death. Time, the cradle of Hope, but the grave of Ambition, is the stern corrector of Fools, but it is the salutary counselor of the Wise, bringing all they dread to the one, and all they desire to the other; but, like Cassandra, it warns us with a voice that even the sagest discredit too long 678

UNIVERSITY SERIES

18 POINT

9 A 20 a \$3 50

DIAMONDS LOCATED IN BOHEMIA

An interesting publication has been made of the discovery of diamonds in Bohemia, in the garnet sands of Dlaschkowitz, on the estate of Count Schonborn, situated at about four 18

12 POINT

12 A 28 a \$3 00

WINES IMPROVED BY ELECTRIC CURRENTS

Mr. Scouteten, in a recent announcement, renews his assertion that a current of electricity passed through wines exercises a very positive influence in ameliorating and improving them, and refers the alteration to the decomposition of the tartrate of potassa by the electric current. The potassa set free neutralizes the acid of the wine, while the tartaric acid combines with its matter 2390

10 POINT

16 A 36 a \$2 75

AVOID DECEIT AND ABUSE

It is astonishing how people persist in practicing deceit. It is the most detestable and vicious agency that can be used in human intercourse. Men in all conditions of life, the lowest as well as the highest, despise and abhor it as an adder. You may slander, abuse and beat 184

8 POINT

20 A 44 a \$2 75

METALS COATED WITH NICKEL

Much interest was experienced at the Academy of Science in Paris, some time since, by the exhibition of various specimens of metallic articles which were electro-plated with nickel by the new process of Mr. Adams, of Boston. This application of nickel is very likely to be of the greatest value from an industrial point of view since the metal thus deposited has a 765

RECHERCHE SERIES

36 POINT

5 A 12 a \$4 00

Usefulness Commands Recognition
Blatant Rhetoric Discounted

30 POINT

6 A 20 a \$3 50

Unfortunate Windy Declamations
Manifold Blessings follow Judicious Industry

24 POINT

7 A 25 a \$2 90

Blatherskite Improvement Association
November 15, 1980, the subject for discussion will be:
Has the eloquence of Orators or the activity of Workers
done most good? Loquacious Theorist, Sec.

18 POINT

8 A 30 a \$2 45

Resolved to Disband our Organization
To secure time for more profitable employment we dissolve the
Society which, in the past, has monopolized our thoughts by day
and our dreams by night By order of the Members

BIJOU SERIES

24 POINT

6 A 14 a \$5 75

Annual Meeting, October 27, 1908,
at which Inventors of our Specialty
may witness the result of past labors

12 POINT

12 A 32a \$4 55

For sale without reserve: Seven female and three
male Unicorns, one Griffin, three mature and nine
juvenile Serpents, one Hippogriff, eight Mermaids,
six Salamanders basking in the glow of a furnace

18 POINT

8 A 20a \$5 35

Blatherskite's Palaverite is recommended for the
use of those desiring Invitations, Gifts, Legacies,
Loans, Puffs, and all who have Axes to Grind

Printing Machinery and Supplies

AS the largest purchasers of Printing
Material in the world, this Com-
pany commands the best of everything for
the printer, and has unsurpassed facilities
for meeting the requirements of printing
offices, from the smallest to the largest

American Type Founders Co.

Branches in all Principal Cities

PENCRAFT SERIES

PATENTED

18 POINT with 36 Point Initials

3 A 4 A 12 a \$6 80

Typographical Appliances
 Accurately Mortised Printing Types
 Recherché Wonders

12 POINT with 24 Point Initials

4 A 8 A 32 a \$5 25

Reminiscences of a Worthy and Honored Citizen
 Local Events Sketched from Memory

To my son Tom, I bequeath all right and title to the Good Name which I intend to leave behind me, and any profit or renown which may be derived therefrom shall be for his sole benefit. To my daughter Mary, I give all shares in the Comet-Tail Utilization Company, and to my wife Clementina my interest in the business of furnishing free Toboggan Rides to women and children. The privilege of giving advice to all comers I leave to Timothy Loudmouth.

1 2 3 4 5 6 7 8 9 0

18 POINT NO 2 with 36 Point Initials

3 A 4 A 20 a \$6 80

Imitative Penmanship Lessons
 Mathematical Reproduction of Signatures
 Progressive Craftsmen

GROLIER SERIES

PATENTED

24 POINT with 36 Point Initials

3 A 4 A 20 a \$7 50

Society to Encourage Industrious Habits
Initiation of Members

*Knowing that the Human Hand, intelligently
 educated and skillfully employed, has delivered*

18 POINT with 30 Point Initials

3 A 6 A 30 a \$6 90

Meeting for Transaction of Business
Expulsion of Members

*Whereas, on the 15th inst. Peter Fiddlefaddle was found
 near the Castle of Indolence, sitting astride a fence, and
 there remained whittling a pine stick for a period of*

12 POINT with 24 Point Initials

4 A 8 A 40 a \$5 60

Report of Committee on Extension of Usefulness
Recommendations for Future Activity

*In the prosecution of our labors we find many persons lying under
 trees expecting fruit to drop into their mouths, others waiting for
 something to turn up, numbers lingering around hoping to step into
 other people's shoes, some who appear anxious to shovel snow in*

ROMAN SLOPE

12 POINT

10 A 32 a \$3 00

MEDIÆVAL MYSTERY CHARM

Will never Work in these Days

Success is no chance luck ; it is knowing how to do a thing and impressing the fact upon others, oftentimes closely allied to the science of putting up a bluff. \$49

MILAN SERIES

18 POINT

15 A 23 a \$3 25

AMERICAN TYPE FOUNDERS COMPANY

United States of America

12 POINT

20 A 36 a \$3 00

RESPECTED SIR :

If you are an observing person and have any interest in the printed page which today forms a large part of the world's intellectual enjoyment, you have no doubt noticed that the most of this kind of work is produced with type made by this concern.

Kindly verify our suggestion.

THE MANAGER.

10 POINT

24 A 46 a \$2 75

WE LEAD THE WORLD NOT ONLY IN FASHIONABLE Type Designs but also in the Volume of Production and the General Excellence of the Finished Article \$12,345.678.90

NORMAN ITALIC

30 POINT

Job Font 6 A 5 A 10 a \$5 22
Circular Font 6 A 5 A 24 a \$7 24

THE SURFSIGN
BEACHMONT

Summer in
1902

18 POINT

Job Font 12 A 8 A 16 a \$4 38
Circular Font 12 A 8 A 50 a \$6 07

BEST WINTER RESORT
NORTH OF FLORIDA

Our hotel will be open this year from about the third Friday in December to the second Sunday in March. Every convenience for the comfort and pleasure both of patrons and visitors. A specialty of our cuisine is broiled live lobster and ale that is musty, with a bird and a bottle at 12 o'clock.

12 POINT Job Font 28 A 16 A 32 a \$4 26
Circular Font 28 A 16 A 60 a \$5 27

OPENED IN SEASON
FOR BATHING

*I*N order that some of our guests may learn to swim after the hotels

10 POINT 24 A 62 a \$3 25

SAIL ALONG THE SHORE
WHEN IT BLOWS

Hotel draws but two feet and is amply provided with ropes and anchors for emergencies

8 POINT 28 A 70 a \$2 75

GUESTS MUST NOT LEAN OUT
OF THE WINDOWS

Danger from passing poles, trees etc. is imminent, and the owners assume no responsibility for \$25

Small Caps are not made for the 8 and 10 Point sizes

24 POINT

Job Font 8 A 6 A 14 a \$4 62
Circular Font 8 A 6 A 36 a \$6 60

GEORGE U. CHASER
DEDHAMSHIRE

Send for Rate
Circular

CHELSEA CIRCULAR

18 POINT

9 A 30a \$5 00

A CELEBRATED HISTORICAL WORK MERITORIOUS RESEARCH

The vastness of the universe must render foolish the supposition that this planet is the only inhabited \$85

12 POINT

12 A 40a \$3 00

LOCAL ABIDING OF A WORTHY AND TRUE CITIZEN EVENTS SKETCHED FROM MEMORY

To my son Tom, I bequeath all right and title to the Good Name which I intend to leave behind me, and any profit or renown which may be derived therefrom shall be for his sole benefit. To my daughter Mary, I give all shares in the Comet-Tail Utilization

10 POINT

18 A 60a \$3 50

MUSCULAR GENTLEMEN EXHIBIT GREATEST ENDURANCE REMARKABLE CHARACTERISTIC METHOD

Health is the soul that animates all enjoyments of life, which fade, and are tasteless, if not dead, without it. Man starves at the best and the greatest tables, makes faces at the most delicate wines, is old and impotent in seraglios of the most sparkling beauties, is poor and wretched in the midst of the greatest treasures; with diseases, strength

8 POINT

24 A 80a \$4 50

ALL SCORING THE PRINTERS CRAFT PUBLICATION

Does the printer read up in his profession as thoroughly as he should? I should say not. It is a deplorable fact, but nevertheless true, that, as a class, the printers of this country do not keep read up on the \$23456

6 POINT

24 A 80a \$4 00

HABITS OF THE SLOUCHY PRINTER GREAT ANNOYING EVILS

Numberless interesting experiments are performed by compositors in the several processes of setting and distributing type, that may be justly classified outside the pale of typographic tolerance. As long as the offender is unnoticed or not discovered in his mean habits, 17890

ISABELLA SERIES

PATENTED

18 POINT

5 A 20 a \$4 15

Invitation to Fashionable Damsels

Display of Paris Styles

Every requirement in quality and cheapness combined in our superior stock of Millinery Goods, Ostrich Plumes and Silk Ribbons

12 POINT

8 A 32 a \$3 80

Headquarters Ladies' Dress Reform Club

Special Circular, No. 23,857

In pursuance of Resolution adopted at the November meeting, members will hereafter, when visiting places of amusement, refrain from wearing towering bonnets and hats decorated with soaring plumage and flowers, as it will be a great benefit to the people in the rear

9 POINT

10 A 35 a \$3 45

Enforced Sale of Fashionable Hats and Trimmings

Entire Stock will be Sacrificed

Owing to resolutions recently passed by the Ladies' Dress Reform Club, the undersigned will dispose of their entire stock of Unique and Stylish Headgear, consisting of Ostrich Plumes and Bonnets. As no reasonable offer will be refused, ladies are invited to call on us and examine this pretty and stylish assortment of goods before the opening of the opera season, which will occur next week

September 4, 1896

Collins & Jackson

CIRCULAR COMMERCIAL

30 POINT

Card Font 6 A 12 a \$3 65
Circular Font 10 A 5 A 42 a \$9 75

METHOD AND MEANS
 WHEN, in course of human
 history, it becomes neces-
 sary for a nation to dissolve
 political bands which have
 connected it with another,
 and to assume among 564

18 POINT

Card Font 10 A 16 a \$2 50
Circular Font 20 A 10 A 125 a \$11 75

INDEPENDENCE TO DECLARE
 WHEN, in the course of human events,
 it becomes necessary for one people to
 dissolve the political bands that have
 connected them with another, and to
 assume among the powers of the earth
 the separate and equal station to which
 the laws of nature and of nature's God
 entitle them, a decent respect for the
 opinions of mankind requires that they
 declare the causes which impel them 52

CIRCULAR COMMERCIAL

12 POINT

Card Font 12 A 20 a \$1 80
Circular Font 48 A 20 A 200 a \$11 25

PATRIOTIC ASPIRATIONS OF PIONEERS

WHEN, in the course of human events, it becomes necessary for one people to dissolve the political bands which have connected them with another, and to assume, among the powers of the earth, the separate and equal station to which the laws of nature and of nature's God entitle them, a decent respect to the opinions of mankind requires that they should declare 123

10 POINT

Card Font 16 A 24 a \$1 80
Circular Font 60 A 25 A 250 a \$12 25

REVOLUTION HEROES COMPOSE INDEPENDENCE

WHEN, in the course of human events, it becomes necessary for one people to dissolve the political bands which have connected them with another, and to assume, among the powers of the earth, the separate and equal station to which the laws of nature and of nature's God entitle them, a decent respect to the opinions of mankind requires that they should declare the causes which impel them to the separation. We hold these truths to be self-evident, that all men are created equal; that they are endowed with certain 456

8 POINT

Card Font 20 A 30 a \$1 75
Circular Font 60 A 25 A 350 a \$11 50

UNITED STATES GOVERNMENT CONSTITUTIONAL DECLARATION

WHEN, in the course of human events, it becomes necessary for one people to dissolve the political bands which have connected them with another, and to assume, among the powers of the earth, the separate and equal station to which the laws of nature and of nature's God entitle them, a decent respect to the opinions of mankind requires that they should declare the causes which impel them to the separation. We hold these truths to be self-evident, that all men are created equal; that they are endowed by their Creator with certain unalienable rights; that among these, are life, liberty and the pursuit of happiness. That, to secure these rights, governments are instituted among men, deriving their just powers from the consent of the governed; that, when 782

IVANHOE SERIES

12 POINT

Card Font 10 A 16 a \$2 40
Circular Font 25 A 125 a \$11 75

WONDERFUL YERKES TELESCOPE AT WORK IN FINE FORM IN WISCONSIN

The object-glass for the Yerkes telescope has been completed and tested, and the giant instrument is now in operation at the new observatory established by the University of Chicago at Lake Geneva, Wisconsin. The Yerkes telescope now takes precedence over the Lick telescope, and an interesting comparison of the two may be 3579

10 POINT

Card Font 10 A 18 a \$2 35
Circular Font 30 A 140 a \$11 85

GREAT CHINESE NAVAL BATTLE OFF YALU RIVER MODERN SHIPS SHELLED

In the great naval battle off the Yalu River last year the Chinese iron-clad battle-ship, Chen Yuen, was commanded by an American named Philo McGriffen, a graduate of the Naval Academy at Annapolis. Captain McGriffen, who has but lately recovered in part from injuries received in this already historic battle, gives many strikingly interesting details illustrative of the terrible nature of a modern naval battle 1658

8 POINT

Card Font 12 A 20 a \$2 40
Circular Font 36 A 150 a \$10 75

THE CRADLE ASKS US WHENCE, AND THE COFFIN WHITHER IS LIFE WORTH ALL OUR ANXIETY

My friends: I know how vain it is to gild a grief with words, and yet I wish to take from every grave its fear. Here in this world, where life and death are equal kings, all should be brave enough to meet what all the dead have met. The future has been filled with fear, stained and polluted by the heartless past. From the wondrous tree of life the buds and blossoms fall with ripened fruit, and in the common bed of earth the patriarchs and babes sleep side by side. Why should we fear that which will come to all that is? We cannot tell, we do not know, which is the greater blessing—life or death. We cannot say 1565

Larger sizes of this series are shown on page 396

Advertising & Poster Type

**A selection of useful Type Styles
adapted to this class of work**

Poster Fonts do not contain Spaces and Quads

**8 Point
Poster
Light-Face
No. 158
72 A 360 a
\$15.85**

THERE is hardly any department of industry to which so much pains and care have of late years been devoted as that of printing; and as one may very readily see, this improvement has come to pass partly through the cultivation of taste and partly through the demands of trade. A cultivated taste has led to a demand for fine books, and the lover of books has carried his taste into the commercial world, and has suggested an improvement in that sphere. The printer has recognized the call for artistic work, and has done his best to supply it; and then again, the advertiser has in turn depended on the printer to produce those novelties of effect which he sees and wishes to imitate. Thus it is that decorative printing has within the last few years become much more prominent as an art than ever before. Any one doubting it should compare 1234567890

**10 Point
Poster
Light-Face
No. 158
48 A 288 a
\$13.65**

LEADING illustrated magazines of the day with those issued fifteen years ago, looking at text, illustrations, and, what has become a conspicuous part of magazines nowadays, the advertisements. Taking, for instance, these last into consideration for a moment, every one remembers the old form which this work always took—a few leading lines in heavy type, and a great deal of text set in rather unreadable small type. It was plain, ugly, but usually intelligible. Now, our advertisements can no longer be described as a class by any term. They are varied, ingenious, artistic, and also far-fetched, vulgar, and confusing. Who is 12345678

**12 Point
Poster
Light-Face
No. 158
40 A 210 a
\$13.00**

NOT to-day familiar with the riotous use and abuse of new types in large sizes with sprawling ornaments, outline vignettes, and heraldic devices surrounded with borders of all degrees of splotchy blackness? Amid the most ingenious confusion, in which every one screams typographically, no one can be heard. Then again the old-fashioned title-page of the early part of this century was not beautiful, but it told its story—often far too long a story for a title-page to tell. To-day, queer half-titles 123456

IN the corner of the page, and title-pages which look as if we were opening into the middle of a book, mystify the reader; these are in one sense striking effects, and for such effects in printing there is a demand; but they are produced at the expense of everything 12345

18 Point
Poster
Light-Face
No. 158
30 A 100 a
\$13.30

ELSE. But because some have managed to impress the public for a moment by very large type and very black borders, and very odd and often badly arranged title-pages, it is believed that by large 1234567

20 Point
Poster
Light-Face
No. 158
24 A 80 a
\$13.60

TYPE, uglier borders, and odder effects, we may get ahead on the principle of the time-worn story of the Irishman and his two stoves, which 1234

24 Point
Poster
Light-Face
No. 158
16 A 60 a
\$13.70

12 Point
Poster
Latin Antique
No. 120
36 A 168 a
\$12.40

THERE is hardly any department of industry to which so much pains and care have of late years been devoted as that of printing; and as one may very readily see, this improvement has come to pass partly through the cultivation of taste, and partly through the demands of trade. A cultivated taste has led to a demand for fine books, and the lover of books has carried his taste into the commercial world, suggesting improvements 12345678

18 Point
Poster
Latin Antique
No. 120
20 A 80 a
\$11.10

IN that sphere. The printer has recognized the call for artistic work, and has done his best to supply it; and then again, the advertiser has, in turn, depended on the printer to produce these novelties of effect which he wishes to 123456

24 Point
Poster
Latin Antique
No. 120
16 A 64 a
\$13.95

IMITATE. Thus it is that decorative printing has within the last few years become much more advanced as an art than before. Any 1234

ONE who doubts
this should com-
pare the illustrated
publications of to-
day with those that
were issued years
ago, looking at the
illustrations, 12345

30 Point
Poster
Latin Antique
No. 120
12 A 36 a
\$14.40

TEXT, and at,
what is quite
a noted feature
in magazines of
the present, the
advers. 123456

36 Point
Poster
Latin Antique
No. 120
8 A 24 a
\$13.80

12 Point
Poster
Eastman
48 A 200 a
\$13.20

THERE is hardly any department of industry to which so much pains and care have of late years been devoted as that of printing; and as one may very readily see, this improvement has come to pass partly through the cultivation of taste, and partly through the needs of trade. A cultivated taste has led to a demand for fine books, and the lover of books carried his taste into the commercial world, and suggested an improvement in that direction. The printer has recognized the call for artistic work, 1234567890

18 Point
Poster
Eastman
20 A 96 a
\$12.70

AND has done his best to supply it; and then the advertiser has in turn depended on the printer to produce those novelties of effect which he sees and wishes to imitate. Thus it is that artistic printing has within a few years become much more prominent 123456

24 Point
Poster
Eastman
16 A 60 a
\$12.40

AN art than ever before; any one who doubts this has only to compare leading illustrated magazines of the day with those printed years ago, looking at the text, 1234

ILLUSTRATIONS,
and, what has become
a most conspicuous part
of magazines nowadays,
the advertisements. Just
take, for instance, these
last in consideration for
a moment, every 23456

30 Point
Poster
Eastman
12 A 45 a
\$14.50

ONE recollects
the old form to
which this work
always held, some
few lines in heavy
type, and a 12345

36 Point
Poster
Eastman
5 A 24 a
\$11.50

10 Point
Poster
Antique
No. 125
72 A 240 a
\$13.25

THERE is hardly any department of industry to which so much pains and care have of late years been devoted as that of printing; and as one may readily see, this improvement has come to pass partly through the cultivation of taste, and partly through the demands of trade. A cultivated taste has led to a demand for fine books, and the lover of books has carried his taste into the commercial world, and has suggested an improvement in that sphere. The printer has recognized the call for artistic work, and has done his best to supply it; and then again, the advertiser has, in turn, depended on the printer to produce those novelties of effect which he sees and wishes to imitate. Thus 1234567890

12 Point
Poster
Antique
No. 125
54 A 180 a
\$12.15

DECORATIVE printing has within the last few years become much more prominent as an art than ever before. Any one who doubts it has only to compare the leading illustrated magazines of to-day with those issued fifteen years ago, looking at text, illustrations, and, what has become a conspicuous part of magazines nowadays, the advertisements. Taking, for instance, these last into consideration for a moment, every one remembers the old form of this work—a few prominent lines 1234567890

18 Point
Poster
Antique
No. 125
24 A 96 a
\$13.50

IN heavy type, and a great deal of text set in rather unreadable small type. It was plain, ugly, but usually intelligible. Now, advertisements can no longer be described as a class by any term. They are varied, clever, artistic, and confusing 1234567

AND vulgar. Who is not nowadays familiar with the extravagant use and abuse of new types in large sizes with sprawling ornaments and 1234567

24 Point
Poster
Antique
No. 125
16 A 64 a
\$13.40

HERALDIC devices, which are inclosed by borders of severest blackness? In this 1234

30 Point
Poster
Antique
No. 125
12 A 36 a
\$14.00

MOST ingenious discord in which every one sees 1234

36 Point
Poster
Antique
No. 125
5 A 20 a
\$11.00

12 Point
Poster
Ionic No. 122
32 A 160 a
\$11.35

THERE is hardly any department of industry to which so much pains and care have of late years been devoted as that of printing; and as one may very readily see, this improvement has come to pass partly through the cultivation of taste, and partly through the demands of trade. A cultivated taste has led to a demand for fine books, and the lover of books has carried his taste into the commercial world, and has suggested many improvements. The 123456789

18 Point
Poster
Ionic No. 122
20 A 100 a
\$13.20

PRINTER has recognized a call for artistic work, and has done his best to supply it; and then again, the advertiser has in turn depended on the printer to produce those novelties of effect which he sees and wishes to imitate. Thus decorative 12345678

24 Point
Poster
Ionic No. 122
16 A 64 a
\$13.25

PRINTING has within the last few years become much more prominent as an art than ever before. Any one who doubts this should compare the 123456

MAGAZINES of to-
 day with those that
 were published fifteen
 years ago, looking at
 text, illustrations, and,
 what has become a con-
 spicuous part of them,
 at the adwers. 1234567

30 Point
 Poster
 Ionic No. 122
 12 A 36 a
 \$13.70

TAKING, for in-
 stance, these last
 in consideration for
 a minute, every one
 remembers the old
 form in which this
 work usually 12345

36 Point
 Poster
 Ionic No. 122
 8 A 24 a
 \$12.60

6 Point
Poster
Old Style
Antique No. 120
120 A 624 a
\$18.50

THERE is hardly any department of industry to which so much pains and care have of late years been devoted as that of printing; and as one may very readily see, this improvement has come to pass partly through the cultivation of taste, and partly through the demands of trade. A cultivated taste has led to the demand for fine books, and [the lover of books has carried his taste into the commercial world, and has suggested an improvement in that direction. The printer has recognized the call of the public for artistic work, and has done his best to supply it; and then again, the advertiser has, in turn, depended on the printer to produce those novelties of effect which he sees and wishes to imitate. Thus it is that decorative printing has within the last few years become much more prominent as an art than ever before. Any one who doubts it has only to compare the leading illustrated magazines of to-day with those issued fifteen years ago, looking at text, illustrations, and, what has become a conspicuous part of magazines nowadays, the advertisements. Taking, for instance, these last into consideration for a moment, every one remembers the old form which this work always took—a few leading lines in heavy type, and a great deal of text set in rather unreadable small type. It was plain, ugly, but usually intelligible. Now, our advertisements can no longer be described as a class by any term. They are varied, ingenious, artistic, and also sometimes far-fetched, vulgar, and confusing. Who is not to-day familiar with the riotous use and abuse of new types, 1234567890

8 Point
Poster
Old Style
Antique No. 120
80 A 400 a
\$14.50

WITH sprawling ornaments, outline vignettes, and heraldic devices surrounded with borders of all degrees of splotchy blackness? Amid the ingenious confusion, in which every one screams typographically, no one can be heard. Then] again the old-fashioned title-page of the early part of this century was not beautiful, but it told its story—often far too long a story for a title page to tell. To-day, queer little half-titles in the corner of the page, and title-pages which look as if we were opening into the middle of a book, mystify the reader. These are in one sense striking effects, and for such effects in printing there is a demand; but they are produced often at the expense of everything else. But because some have managed to impress the public for a moment by very large type and very black borders, and very odd and often very bad arrangements of title pages, it is supposed that by larger type, uglier borders, and odder effects we may get ahead, on the principle of the time-worn story of the Irishman and the two stoves, which were to save his fuel. 1234567890

10 Point
Poster
Old Style
Antique No. 120
54 A 288 a
\$13.45

IN other words, a great deal of the so-called decorative printing is not decorative, and what modern printing needs is simplicity and harmony. Very few people know any more than formerly about specific styles of type, or understand that there are any principles underlying arrangement. The reason that many pieces of careful work are failures is because they have neither simplicity nor harmony. In the long run there is much more variety as well as harmony to be gained by keeping certain sets of types by themselves and using them with each other only, than by mixing them all up together. For instance, there are certain sorts of old-style types, which, combined with bold and rough ornaments of an English style, and 1234567890

INCLOSED in panels of double rules, form a style which suggests itself naturally for reprints of old books, pamphlets, etc., and, indeed, anything with an anti-quarian flavor. French type in roman lower-case may be combined with Louis XIV. ornaments, and which are easily had, and when the work is done this has a certain light, graceful look which suits slight, ephemeral bits of work. The above combined with Elzevir italic type, with ornaments in black, such as are often seen in volumes of 1234567

12 Point
Poster
Old Style
Antique No. 120
48 A 192 a
\$12.60

SHORT stories, is another distinctively French style, while roman type with Caxton headlines and large black-letter initials is appropriate for sober work. Thus there are four distinct and harmonious styles obtained by a careful use of types, which often appear 1234567890

18 Point
Poster
Old Style
Antique No. 120
24 A 96 a
\$12.45

ALONE, and have no effect whatever.

24 Point
Poster
Old Style
Antique No. 120
16 A 48 a
\$12.40

This is all very well, but what has a business man to do with those finical definitions of style 1234

12 Point
Poster
French O. S.
Extended
45 A 180 a
\$14.25

THERE is hardly any department of industry to which so much pains and care have of late years been devoted as that of printing; and as one may readily see, this improvement has come to pass partly through the cultivation of taste, and partly in response to the demands of the trade. A cultivated taste demanded fine books, and the lovers of books have carried their tastes into the commercial 1234567890

18 Point
Poster
French O. S.
Extended
24 A 80 a
\$12.60

WORLD, and have introduced improvements into that sphere. The printer has recognized the call for artistic work, and has done his best to supply it; and then again, advertisers have in turn depended on printers 1234567

24 Point
Poster
French O. S.
Extended
12 A 48 a
\$11.80

TO reproduce those novelties or effects which they see and desire to imitate. Thus it came about that decorative printing in 1234

THE last years
is more promi-
nent as an art than
it ever was before.
Any one who does
not credit this has
only to compare an
illustrated 1234567

30 Point
Poster
French O. S.
Extended
10 A 40 a
\$15.00

PERIODICAL
of to-day with
one issued eight
years ago, exam-
ining the text, as
well as the 1234

36 Point
Poster
French O. S.
Extended
8 A 32 a
\$15.40

12 Point
Poster
De Vinne
Extra Cond.
60 A 312 a
\$11.50

THERE is hardly any department of industry to which so much pains and care have of late years been devoted as that of printing; and as one may very readily see, this improvement has come to pass partly through the cultivation of taste, and partly through the demands of trade. A cultivated taste has led to a demand for fine books, and the lover of books has carried his taste into the commercial world, and has suggested an improvement in that sphere. The printer has recognized the call for artistic work, and has done his best to supply it; and then again, the advertiser has in turn depended on the printer to produce those novelties of effect which he sees and wishes to imitate. Thus it is that decorative printing has within the last few years become more prominent as an 1234567890

14 Point
Poster
De Vinne
Extra Cond.
54 A 198 a
\$11.40

ART than ever before. Any one who doubts it has only to compare the leading illustrated magazines of to-day with those issued fifteen years ago, looking at text, illustrations, and, what has become a conspicuous part of magazines nowadays, the advertisements. Taking, for instance, these last into consideration for a moment, every one remembers the old form which this work always took—a few leading lines in heavy type, and a great deal of text set in rather unreadable small type. It was plain, but usually 12345678

18 Point
Poster
De Vinne
Extra Cond.
36 A 140 a
\$11.05

INTELLIGIBLE. Now, our advertisements can no longer be described as a class by any term. They are varied, ingenious, artistic, and also sometimes far-fetched, vulgar, and very confusing. Who is not to-day familiar with the riotous use and abuse of new types in large sizes, with sprawling ornaments, outline vignettes, and heraldic devices surrounded with inartistic and black borders? 1234567

AMID this intellectual confusion, in which every one screams typographically, no one can be heard. Then again the old-fashioned title-page of the early part of this century was not beautiful, but it told its story, often too long a 1234567

24 Point
Poster
De Vinne
Extra Cond.
20 A 96 a
\$10.95

STORY for a title-page to tell. To-day, queer little half-titles in the corner of the page, and title-pages which look as though we were opening the middle of a book, 12345

30 Point
Poster
De Vinne
Extra Cond.
16 A 60 a
\$11.55

ASSUREDLY mystify the reader. These are in one sense striking effects, and for such effects in printing 123456

36 Point
Poster
De Vinne
Extra Cond.
12 A 48 a
\$13.25

12 Point
Poster
De Vinne
Condensed
72 A 264 a
\$14.50

THERE is hardly any department of industry to which so much pains and care have of late years been devoted as that of printing; and as one may very readily see, this improvement has come to pass partly through the cultivation of taste, and partly through the demands of trade. A cultivated taste has led to a demand for fine books, and the lover of books has carried his taste into the commercial world, and has suggested an improvement in that sphere. The printer has recognized the call for artistic work, and has done his best to supply it; and then again, the advertiser has, in turn, depended on the printer to produce those novelties which 1234567890

14 Point
Poster
De Vinne
Condensed
48 A 180 a
\$13.10

HE sees and wishes to imitate. Thus it is that decorative printing has within the last few years become much more prominent as an art than ever before. Any one doubting it has only to compare the leading illustrated magazines of to-day with those issued fifteen years ago, looking at text, illustrations, and, what has become a conspicuous part of magazines nowadays, the advertisements. Taking these last into 1234567890

18 Point
Poster
De Vinne
Condensed
30 A 128 a
\$13.75

CONSIDERATION for a moment, all remember the old form which this work always took—a few leading lines in heavy type, and a great deal of text set in rather unreadable small type. It was plain, ugly, but usually intelligible. Now, advertisements can no longer be described as a class by any term. 12345678

THEY are varied, clever, artistic, and sometimes vulgar and confusing. Who is not to-day familiar with the riotous use and abuse of new types in large sizes with sprawling 123456

24 Point
Poster
De Vinne
Condensed
16 A 84 a
\$12.15

ORNAMENTS, outline vignettes, and heraldic devices within borders of every degree of blackness? Amid the ingenious 123456

30 Point
Poster
De Vinne
Condensed
12 A 54 a
\$14.00

CONFUSION, when every one screams typographically, none can be heard. 1234567

36 Point
Poster
De Vinne
Condensed
10 A 40 a
\$15.40

6 Point
Poster
De Vinne
240 A 900 a
\$29.00

THERE is hardly any department of industry to which so much pains and care have of late years been devoted as that of printing; and as one may very readily see, this improvement has come to pass partly through the cultivation of taste, and partly through the demands of the trade. A cultivated taste has led to a demand for fine books, and the lover of books has carried his taste into the commercial world, and has suggested an improvement in that sphere. The printer has recognized the call for artistic work, and has done his best to supply it; and then again, the advertiser has in turn depended on the printer to produce those novelties of effect which he sees and wishes to imitate. Thus it is that decorative printing has within the last few years become much more prominent as an art than ever before. Any one who doubts it has only to compare leading illustrated magazines of to-day with those issued fifteen years 1234567890

8 Point
Poster
De Vinne
132 A 540a
\$22.50

AGO, looking at text, illustrations, and, what has become a conspicuous part of magazines nowadays, the advertisements. Taking, for instance, these last into consideration for a moment, every one remembers the old form which this work always took—a few leading lines in heavy type, and a great deal of text set in rather unreadable small type. It was plain, ugly, but usually intelligible. Now, our advertisements can no longer be described as a class by any term. They are varied, ingenious, artistic, and also sometimes vulgar, far-fetched, and confusing. Who is not to-day familiar with 1234567890

10 Point
Poster
De Vinne
100A 390a
\$18.50

THE riotous use and abuse of new types in large sizes with bungling ornaments, outline vignettes, and heraldic devices surrounded with queer borders of all degrees of splotchy blackness? Amid the ingenious confusion, in which every one screams typographically, no one can be heard. Then again the old-fashioned title-page of the early part of this century was not beautiful, but it told its story—often 1234567890

12 Point
Poster
De Vinne
64 A 240 a
\$16.50

FAR too long a story for a title-page to tell. To-day, queer little half-titles in the corner of the page, and title-pages which look as if we were opening into the middle of a book, mystify the reader. These are in one sense striking effects, and for such effects in printing 1234567890

14 Point
Poster
De Vinne
48 A 180 a
\$14.80

THERE is a demand; but they are produced often at the cost of everything else. Because some have managed to impress the public for a moment by very large type and very black borders, and very odd and often very bad arrangements of 1234567

TITLE=PAGES, it is supposed that by larger type, uglier borders and odder effects we may get ahead, on the principle of that time-worn story of the Irishman and the two stoves, which were 1234567

18 Point
Poster
De Vinne
30 A 112 a
\$15.00

TO save all his fuel. Or in other words, a great deal of the so-called decorative printing is not artistic, and what modern 1234567

24 Point
Poster
De Vinne
24 A 60 a
\$14.00

PRINTING of most every kind needs is simplicity and beauty. Very few people 12345

30 Point
Poster
De Vinne
12 A 45 a
\$14.00

TO=DAY know any more than formerly the 1234

36 Point
Poster
De Vinne
10 A 32 a
\$15.00

12 Point
Poster
Schœffer
Old Style
80 A 320 a
\$15.50

THERE is hardly any department of industry to which so much pains and care have of late years been devoted as that of printing; and as one may very readily see, this improvement has come to pass partly through the cultivation of taste, and partly through the demands of the trade. A cultivated taste has led to a demand for fine books, and the lover of books has carried his taste into the commercial world, and has suggested an improvement in that sphere. The printer has recognized the call for artistic work, and has done his best to supply it; and then again, the advertiser has in turn depended on the printer to produce those novelties of effect which he sees and wishes to imitate. Thus it is that decorative printing has within the last few years become much more prominent as an art than ever before. Any one who doubts it has only to compare leading illustrated magazines of to-day with those issued fifteen years ago, looking at text, illustrations, and, what has become a conspicuous part of magazines nowadays, the advertisements. Taking 1234567890

15 Point
Poster
Schœffer
Old Style
54 A 180 a
\$13.25

THESE last into consideration for a minute, every one remembers the old form which this work always took—a few leading lines in heavy type, and a great deal of text set in rather unreadable small type. It was plain, ugly, but usually intelligible. Now, our advertisements can no longer be described as a class by any term. They are varied, ingenious, artistic, and also sometimes far-fetched, vulgar, and confusing. Who is not to-day familiar with the riotous use and abuse of new types in large sizes with sprawling ornaments, outline vignettes, and heraldic devices surrounded with borders of all degrees of splotchy blackness? Amid the ingenious confusion, in which every one screams typographically, no one seems to be heard. Then 1234567

AGAIN, the old-fashioned title-page of the early part of this century was not beautiful, but it told its story—often far too long a story for a title-page to tell. To-day, queer little half-titles in the corner of the page, and title-pages which look as if we were opening into the middle of a book, mystify the reader. These are in one sense striking effects, and for such effects in printing there is a demand; but they are produced often at the expense of everything else. But because some have managed to impress the public for a moment 1234

18 Point
Poster
Schœffer
Old Style
45 A 150 a
\$15.50

BY very large type and very black borders, and very odd and often very bad arrangements of title-pages, it is supposed that by larger type, uglier borders, and odder effects, that we may get ahead, on the principle of the time-worn story of the Irishman and the two stoves, which were to 1234567

24 Point
Poster
Schœffer
Old Style
24 A 90 a
\$13.65

30 Point
Poster
Schæffer
Old Style
16 A 48 a
\$13.25

SAVE all his fuel. Or, in other words, a great deal of the so-called artistic printing is not artistic; and what modern printing of all kinds needs is simplicity, harmony, and beauty. Very few people know any more than 12345

36 Point
Poster
Schæffer
Old Style
12 A 27 a
\$12.20

FORMERLY about a specific style of type, or understand that there are any principles underlying arrangement. The reason that many 12345

Script Type

*Adaptable for
Wedding Stationery
Invitations, Notices
Cards, etc.*

AMERICAN SCRIPT

See following pages for sizes and prices

Mr. & Mrs. Jacob Brandt

request the honour of your presence

at the marriage of their daughter

Charlotte D.

to

Mr. Frederick Branden Wampole

Thursday evening, November twentieth,

at eight o' clock,

1527 North American Street,

Baltimore.

1900.

P. Howard Bertram

Attorney-at-Law

AMERICAN SCRIPT

60 POINT

3 A 8 a \$10 00

*Beautiful Invitations
in this Celebrated Script*

48 POINT

4 A 10 a \$9 00

*Elegance and Usefulness for
the Printer are combined in the
Artistic Design of this Series*

36 POINT

5 A 15 a \$8 00

*Compositors and Lovers of good Taste
in Printing will readily Appreciate this
perfect Reproduction of Penmanship*

See practical showing on page 185

AMERICAN SCRIPT

30 POINT

Card Font 3 A 10 a \$4 25
Circular Font 7 A 20 a \$7 50

You are Cordially invited to attend a Public Reception in the new Academy of Music in Honor of our Glorious Victories in the War

24 POINT

Card Font 4 A 11 a \$4 00
Circular Font 8 A 22 a \$7 00

In calling the attention of Customers and Friends to our Removal from the Old Stand, we desire to express our Sincere Gratitude for their previous Liberal Patronage

18 POINT

Card Font 5 A 12 a \$3 50
Circular Font 9 A 24 a \$6 00

The New Store will be inaugurated with a Bargain Sale in every Department. We have spared neither money nor labor to make this the Greatest Opening in the History of the City, and we hope that our Patrons will appreciate our motto: Large Sales and Small Profits

12 POINT

Card Font 5 A 16 a \$3 00
Circular Font 10 A 32 a \$5 00

Some time ago we mentioned that our French Agent, Monsieur Rigmarole, had bought at a Very Low Figure the Entire Stock of a large manufacturer of Artificial Flowers. These Flowers were used in Trimming Hats in our own Workrooms, and, as we anticipated, they caught the Public Fancy. While lacking nothing of French Dash, Spirit, Originality or Tone, these Creations of Exquisite American Millinery have the advantage of Low Prices

1 2 3 4 5 6 7 8 9 0

See practical showing on page 185

ROYAL SCRIPT

30 POINT NO 1

Card Font 4 A 10 a \$5 00
Circular Font 7 A 20 a \$9 00

*Men are always helpful through the
Intellect and the Affections. Other
Help I find is a false appearance.
If you affect to give me bread 127*

30 POINT NO 2

Card Font 4 A 12 a \$5 00
Circular Font 7 A 24 a \$9 00

*Man regards his century or his Half-
Century as the culmination of Light, as
a Festival-day, to which all other centuries
Lead only as week-days. He can 1898*

24 POINT NO 1

Card Font 4 A 10 a \$4 50
Circular Font 8 A 20 a \$7 50

*Reading is well Compared to the Filling
of a Granary with grain, and thinking to
Nothing but Sowing the seed. We should
Always weigh and consider, not contradict.
Meditation is active; reverie, idle thought 35*

ROYAL SCRIPT

24 POINT NO 2

Card Font 4 A 12 a \$4 50
Circular Font 8 A 22 a \$7 50

Among all the Accomplishments of Life none is so Important as Refinement; Unlike beauty, Nature is not its Parent. By Cultivation and Everlasting practice only can it be acquired 467

18 POINT

Card Font 4 A 12 a \$3 50
Circular Font 8 A 24 a \$6 00

The moral Character that any Person has attained at thirty-five years is as permanent as the intellectual. If he has been pursuing the Noblest Aims, he will continue to Follow them for the Rest of his Life, and they will Become more Deeply Imbedded in his Character 350

12 POINT

Card Font 5 A 16 a \$3 00
Circular Font 10 A 32 a \$5 00

By Christianity a Moral motive-power is Supplied, which is Far better than any fact or Enactment in Keeping society together: And that is, the charity that is not easily provoked, the love that works no Ill to any of his Neighbors. To the motives which tend to Insure Well-being in this world it adds loftier Hopes, the nobler Aspirations, the better Purposes, that blind the Christian to an endless future. It helps him to be a Better citizen 192

10 POINT

10 A 32 a \$4 50

Beloved, the Earth is to-day so beautiful! that, indeed, makes Man more Tender; the Heavens rest with a Caress and Kiss of Love on the Earth as a Father on a Mother on her Children. The Flowers and beating Hearts fall into the embrace and nestle around the Mother; the Twig gently Rocks its Finger up and down, the leaf cradles its fly, the Flower its bee and its Drop of Honey; in the open flower-cups hang the warm Tears into which the Clouds dissolve themselves, as if in Eyes 1875

STEELPLATE SCRIPT

PATENTED

30 POINT NO 1

Card Font 4 A 10 a \$5 00
Circular Font 7 A 20 a \$9 00

The Excellence of Religion is Shown
By the Fact that Many Pretended
To possess it. The Odorous Balsam is
Easily imitated, because it is so precious
And Fragrant, and Necessarily there
Are many Spurious kinds; But \$639

30 POINT NO 2

Card Font 4 A 12 a \$5 00
Circular Font 7 A 25 a \$9 00

The Poor man is Hungry and Athirst: but
Even for him there is always Food and Drink.
He is often Heavy-Laden and Weary: but
For him also Heaven sends Sleep, and this of
The Deepest; In his Smoky Crib, a Clear
Dewy heaven of Rest envelops him \$21547

STEELPLATE SCRIPT

PATENTED

24 POINT NO 1

* Card Font 4 A 12 a \$4 00
Circular Font 8 A 22 a \$7 00

*Let Honesty be the Breath of thy Soul, and
Never Forget to have a Penny or Two, when
All thy Expenses are Enumerated and paid.
Then Shalt Thou safely reach the Point of
Happiness, and Independence Shall be 384*

24 POINT NO 2

Card Font 4 A 14 a \$4 00
Circular Font 8 A 28 a \$7 00

*True Life can never be well Developed among Throngs
And Noises. We must Betake Ourselves into the
Remote desert Places. In a word, we must get away
From Men and View Life from such Distance as
May be Realized by Intimate Divine Fellowmen 576*

12 POINT

Card Font 5 A 16 a \$3 00
Circular Font 10 A 32 a \$5 00

*Ambition, that High and Glorious Passion, which makes such
Harac among the Sons of Men, Arises from a Proud Desire of
Honor and Distinction, and when all those Splendid Trappings
In which it is usually Caparisoned, are Removed, will be found
To Consist of Mean Materials of Envy, Pride and Covetousness.
It is Described by the Different Authors as a Gallant Madness, a
Pleasant Poison, a Hidden Plague, a Secret Poison, the 12790*

BOSTON SCRIPT

60 POINT

3 A 8 a \$15 00

Bravest victory
gained in battle
by our troops 42

48 POINT

4 A 10 a \$12 00

The society will use
the Custer building
until quarters for 27
members are secured.

BOSTON SCRIPT

36 POINT

5 A 15 a \$10 00

You are reminded that the care given to Script type regulates period of usefulness 278

24 POINT

Card Font 3 A 8 a \$3 00
Circular Font 7 A 20 a \$8 00

Measure the existence of perishable or easily injured Articles only after Proper Treatment has been given to them \$34,690

18 POINT

Card Font 3 A 10 a \$2 00
Circular Font 9 A 25 a \$6 00

You are requested to attend the Seventeenth Annual Dance to be given under our auspices in Pythian Hall, on Hobson Boulevard, Thursday evening the 25th of December, 1897. Music, Fusillade Orchestra of Eight

A M N

These extra Capitals are put up separately at the following prices: 48 Point, \$1.00; 36 Point, 75 cents; 24 Point, 75 cents; 18 Point, 50 cents.

SPENCERIAN SCRIPT

PATENTED

60 POINT

3 A 9 a \$17 60

Highway Inspectors
Coast Surveyor
Water Departments.

40 POINT

Card Font 5 A 25 a \$20 00
Circular Font 10 A 50 a \$40 00

Fifth Annual Drive
Philadelphia to Somewhere.
Hornblowing at Sunrise,
on November the 28th, 1903.
Dinner at Whip Mansion

SPENCERIAN SCRIPT

PATENTED

28 POINT

Card Font 8 A 30 a \$14 40
Circular Font 16 A 60 a \$28 75

M^{rs} Gushington & Daughter
Tender the advantages of their company
during summer vacations to any family
whose rural antecedents were always 762

22 POINT

Card Font 9 A 50 a \$13 65
Circular Font 18 A 100 a \$27 25

This Useful Series of Scripts
Which we call Spencerian, we present to the
attention of Printers in the assured confidence
that it will meet with their hearty approval.
Its elegant appearance is not its only 9073

16 POINT

Card Font 9 A 50 a \$9 15
Circular Font 18 A 100 a \$18 30

This Combination of late Improvements
Is presented for further appreciative consideration. Its
tones are of a magnificent singing quality, of marvellous
volume and strong penetrating power, and in perfect
sympathy with the human voice, while the wave-like
melodies of its softer modulations enchant all by their
purity, increasing the delights of home and enhancing 4672

M^{rs} M^r D^r C^r the V.C. Th. Pl. Wh

SPENCERIAN SCRIPT No 2

40 POINT

Card Font 2 A 5 A 25 a \$20 75
Circular Font 4 A 10 A 50 a \$41 50

Meeting for Promotion
Friday Evening, May 7, 1895

28 POINT

Card Font 3 A 8 A 30 a \$16 05
Circular Font 6 A 16 A 60 a \$32 05

Distribution of Greenbacks
This Petition of male inhabitants of the
township of Loafedom, in the County 563.

22 POINT

Card Font 3 A 9 A 50 a \$14 05
Circular Font 6 A 18 A 100 a \$28 05

Lessons in the Arts and Mysteries of Courtship
Methods for Becoming Fascinating
The commodious Steamer Orange Blossom, expressly
built for our Skymeneal trade, will make its 2534

16 POINT

Card Font 3 A 9 A 50 a \$10 35
Circular Font 6 A 18 A 100 a \$20 65

Cabalistic Observances and Initiation of Members
Every Wednesday and Friday Evening
The Examiners and Faculty of the University of Teachem-
fast, in the City of Classic Lore, do hereby Certify 7809

The Ornamented Capitals may be used with both Series of Spencerian Script, and may be purchased separately at following prices: 16 Point, 6A, \$2.40; 22 Point, 6A, \$3.30; 28 Point, 6A, \$4.30; 40 Point, 4A, \$5.60

REVERE SCRIPT

48 POINT

4 A 15 a \$12 00

Gratitude from the Steady
Harvard University 153

36 POINT

5 A 18 a \$10 00

Insurance upon Stores and Factories
Everettsville Overseers of Lithography

24 POINT

7 A 27 a \$8 00

You are earnestly requested to bring your Tobacco Pouch
to the approaching Smoke Talk of the well-known and
extremely popular monthly gatherings of our members \$4750

A M N R

The above extra Capitals are put up separately and furnished at the following prices

48 POINT \$1 00 36 POINT 75 CENTS 25 POINT 50 CENTS

OLD STYLE SCRIPT

30 POINT

Card Font 3 A 9a \$5 00
Circular Font 6 A 18a \$9 00

As the popularity of the old style effects in type designs does not seem to be waning, we know

24 POINT

Card Font 3 A 10a \$4 50
Circular Font 6 A 20a \$8 00

Florence can still ring her belly with the solemn hammer sound that used to beat on the hearts of her citizens and strike out the fire there. And where

18 POINT

Card Font 4 A 12a \$3 50
Circular Font 8 A 24a \$6 00

Life had its zest for the old Florentine when he, too, trod the marble steps and shared in those dignities. His politics had an area as wide as his trade, which stretched from Syria to Britain, but they had also the new

12 POINT

Card Font 5 A 16a \$3 00
Circular Font 10 A 32a \$5 00

Even if, instead of following the dim day-break, our imagination pauses on a certain historical spot and awaits the fuller morning, we may see a world-famed city, which has hardly changed its outline since the days of Columbus, seeming to stand as an almost unviolated symbol, among the flux of human things, to remind us that we still resemble the men of the past more than we differ from them, as now

TITLE SCRIPT

48 POINT

4 A 12 a \$12 10

*Annual Excursion
Editors First Convention
Hammond 63 Indiana*

32 POINT

Card Font 3 A 8 a \$4 75
Circular Font 5 A 25 a \$10 50

*True Scenic Grandeur
Boston Excursion Association will
again visit Lake Champlain with a
Number of very Select People 214*

24 POINT

Card Font 4 A 12 a \$4 00
Circular Font 8 A 50 a \$11 45

*Great Unselfishness of Conduct
Among all the Accomplishments of Life none
Is so important as Refinement; Unlike beauty,
Nature is not its Parent. By Cultivation 795*

LADIES' HAND SCRIPT

32 POINT

Card Font 3 A 8 a \$4 50
Circular Font 5 A 25 a \$10 00

The Poor man is Hungry and Athirst
But even for him There is always 348

32 POINT NO 2

Card Font 3 A 8 a \$4 75
Circular Font 5 A 25 a \$10 80

Excellence of Religion is Shown
By the Fact that Many are 170

24 POINT

Card Font 4 A 12 a \$4 00
Circular Font 8 A 50 a \$10 90

Madame Le Bostonio and Daughter Angelina
Elegant Minutia of Fashionable Etiquette 189

24 POINT NO 2

Card Font 4 A 12 a \$4 50
Circular Font 8 A 50 a \$12 55

Agricultural Products Exchanged Quickly
Fourteen Dollars and Seven Cents 407

18 POINT

Card Font 6 A 16 a \$3 75
Circular Font 10 A 75 a \$9 00

Now comes Winter, as Savage as when He met the Ambitious Pilgrims
At Plymouth, Indians all over, a Naked, Splintery Hemlock for 325

18 POINT NO 2

Card Font 6 A 16 a \$3 75
Circular Font 10 A 75 a \$10 75

Reading is well Compared to the filling of a Granary with
Grain, and Thinking of Nothing but Sowing the Seed 94

CIRCULAR SCRIPT

24 POINT

10A 50a \$18 65

Actuated by philanthropic motives, we determine to devote our fortunes and the labor of life to the benefit of mankind.

18 POINT

10A 50a \$12 20

Rubhard Lively, M. D.

Dear Sir:— I am troubled with Weakness of the Back and an Indisposition to Labor. If you can cure me of this disease you will receive the lasting gratitude of

Yours truly,

Gregory Lackthrift

12 POINT

10A 50a \$7 00

Gregory Lackthrift.

Dear Sir:— Having carefully studied all the symptoms of your Case, I have forwarded to your address a package of superior Elbow Grease, which, if diligently and perseveringly applied, from 7 a. m. to 6 p. m., daily, will relieve your troubles. To prevent a recurrence of the disease, Industrious Habits must be formed, and exercise of a quickstep character freely indulged in.

Rubhard Lively, M. D.

FRENCH SCRIPT

54 POINT

3 A 9 a \$12 20

Ogontz Courier

Buck & Sons
834 Oak Lane

44 POINT

4 A 12 a \$11 25

Art Publishers
Engravers and
Book Makers

FRENCH SCRIPT

36 POINT

5 A 14 a \$10 75

History of Greek Literature
Wonderful Discovery

Mr & Mrs Anthony Southwick

Requests the Pleasure of your Company

at the rooms of the

Semi-Weekly Reading and Debating Association

Friday Evening, June 15th, at 8 o'clock

North Willow Grove

12 POINT . . . 10 A 35 a \$4 00

22 POINT . . . 7 A 22 a \$7 25

28 POINT

6 A 18 a \$8 90

Concise and Interesting
From Earliest Times to Present
Superb Reading

Continued on page 204

FRENCH SCRIPT

Gun, Food & Bait Company

18 POINT

8 A 24 a \$6 00

High-grade Goods, as choice as any in Southern Montana, will be found here and in a most extensive variety. For many years this Old Established Sportsmen's Furnishing House has been noted for the production of everything new and novel in the

Sporting World

14 POINT

9 A 30 a \$5 00

And this year is no exception to former ones, for our Stock embraces all the new ideas in shapes, trimmings and combinations, including many designs from out-of-town makers. Good Judges of the Sport's Requisites are our best customers. We secured their patronage by our low prices, and hold it by the excellence of our goods. We do not misrepresent our wares. Try any of our Productions and then Judge for yourself

Cor. Ninth and Hunter Sts.

SANSOM SCRIPT

36 POINT

6 A 30 a \$15 00

Profitable Business
Rushlight Manufacturing Co.
No. 6941 Glimmer St.

24 POINT

10 A 50 a \$12 50

Stockholders, Attention!
Financial necessities compel the Management
to order an assessment on every share of stock of
the Rushlight Manufacturing Company, 230

18 POINT

10 A 50 a \$9 30

Guaranteed Dividends, one Hundred per Cent.
Formation of a new Company
Our facilities for manufacturing Rushlights are excellent,
and, as you are one of our intimate friends, we offer you
the privilege of coming into our corporation on the ground
floor. The par value of our shares is \$96.58, but, if

VERTICAL WRITING

24 POINT

7 A 22 a \$6 00

Replacing Materials
Worn round by long years
of Usefulness in Service
of the People

8 POINT

18 A 50 a \$3 25

Printers should remember that all the tasteful and useful styles of types and ornaments made by this Company are for sale in any quantity at right prices

10 POINT

12 A 40 a \$3 50

Order from Branch House nearest your place of business and you will receive what is wanted quickly 16

12 POINT

10 A 35 a \$4 00

Headquarters Educational Committee
478 Washington Street

To the Printer:

As the typewriter letters imitate the work of a machine, so does the Vertical Writing faithfully portray the handwriting of the generation now growing up, and consequently its field of usefulness will extend into the future.

American Type Founders Co.

VERTICAL WRITING

36 POINT

5 A 15 a \$9 00

Capacity for Making
the Desirable Grades of
Fresh Business Letters
in Year 1902

18 POINT

8 A 25 a \$4 75

Largest Concern in the World
Matchless Facilities

Together with highest expert artistic
and mechanical skill, enables us to
furnish the Best Articles in shortest
time on the most liberal terms \$265

New Spring Design
Ready for your Approval

DEVENS SCRIPT

18 POINT

8 A 24 a \$4 50

Latest New Character Script
In Five Sizes

This is a reproduction in type of the handwriting of the Rev. Richard M. Devens. In cutting the various letters, absolute fidelity to the original penmanship of Mr. Devens was adhered to, even when in so doing the taste of the Type Founder was violated, and the result is a most delightful symphony in type.

1 2 3 4 5 6 7 8 9 0

12 POINT

12 A 30 a \$4 25

Rubhard Swively, M.D.
64 Ash Street

Malden, August 25, 1898.

Gregory Sackthrift,

Dear Sir:—Having carefully studied all the symptoms of your case, I have forwarded to your address a package of superior Elbow Grease, which, if diligently and perseveringly applied, will relieve your troubles. To prevent a recurrence of the disease, industrious habits must be formed, and some exercise of a quickstep character freely indulged in.

Rubhard Swively.

DEVENS SCRIPT

10 POINT

16 A 40 a \$4 00

*Brown & Ferguson,
Attorneys and Counsellors at Law,
Court Square.*

Boston, September 20, 1898.

Gentlemen:—In our circular recently mailed you we attempted a review of the business as carried on by the late firm, giving them due credit for what they have done, and without any intention to belittle their efforts. But the best intentions are often misconstrued, and sometimes intentionally. We see no objection to a fair, open criticism of the facts in the letter, should anyone feel it incumbent upon him to do so and to think that any good would come of it. It is deemed necessary to call a Special Meeting for Tuesday, October 9.

Respectfully yours,

Brown & Ferguson.

6 POINT

20 A 50 a \$3 50

*I sit by the fire this cold winter morning,
The red coal lies under, and on the top lies
A log of green hickory, that sings in its burning,
So a martyr might sing as he mounts to the skies.*

*The red coal lies uncer — great lumps of bitumen,
One cheek in the dawning and one in the night,
From their own substance feeding the flame they consume in,
They die, and in dying give being to light.*

*So — so would I perish. No matter what life is :
Be it in the forest, be it in the mine !
If life and its song the ripe fruit of its strife is,
The flame-eaten heart is becoming divine.*

8 POINT

18 A 44 a \$3 75

*Headquarters
Ladies Dress Reform Club
Quincy.*

In pursuance of resolutions adopted at the November meeting, members will hereafter, when they visit places of public amusement, refrain from wearing bonnets and hats decorated with high-soaring plumes or flowers. The bald-headed fraternity has at last made a successful protest, and the State Legislature has decided that all headgear which will obstruct the view must be removed.

Per order Directors,

Mrs. Newfashion, Secretary

GOTHAM SCRIPT

24 POINT Card Font 4 A 10a \$4 95

Job Font 8 A 20a \$9 90
Circular Font 12 A 50a \$19 35

*Members of the Stock Exchange
In account with Youngin & Co.*

18 POINT Card Font 4 A 10a \$3 25

Job Font 8 A 20a \$6 50
Circular Font 12 A 50a \$12 75

*The Formation of this very Elegant Series
of Script is especially adapted to High-Class*

12 POINT Card Font 4 A 15a \$3 00

Job Font 8 A 30a \$6 00
Circular Font 12 A 50a \$9 00

*Your Presence at the Examination of this Beautiful
and Popular Description of Types is Joyfully 45678*

HERRIET SCRIPT

24 POINT Card Font 4 A 10a \$4 50

Job Font 8 A 20a \$9 00
Circular Font 12 A 50a \$17 10

*Accumulators of Financial Wisdom
Cognate Understanding, London*

18 POINT Card Font 4 A 10a \$3 10

Job Font 8 A 20a \$6 20
Circular Font 12 A 50a \$12 00

*All the accomplishments and graces of Charm-
ing and Beautiful Womanhood, by Professor of*

12 POINT Card Font 4 A 15a \$3 00

Job Font 8 A 30a \$6 00
Circular Font 12 A 50a \$9 00

*The small and exquisitely beautiful Handwriting of many
Worthy Clergymen and some Ladies of Good Taste 1874652*

CARPENTER SCRIPT

30 POINT

Card Font 4 A 16 a \$6 50
Circular Font 8 A 32 a \$12 50

*This Beautiful Script is well
Adapted to artistic Work, 1898*

22 POINT

Card Font 4 A 16 a \$4 50
Circular Font 8 A 32 a \$8 50

*Summer Excursions to the Lake Resorts
rendered safe and pleasant by our steamers
Making daily Trips to and from the 6530*

CLEVELAND SCRIPT

24 POINT

Card Font 4 A 16 a \$4 50
Circular Font 8 A 32 a \$8 50

*We here present for your approval the
scheme of every Loyal Sir Knight
contributing to the Relief Fund 2568*

MAGNOLIA SCRIPT

24 POINT

7 A 20 a \$7 00

*Caesar had made a Will, and that will was
Produced and Read to the people. It was of
A character to Shame his Enemies, and to
Make his Friends more indignant 1234567*

MANUSCRIPT No 1

24 POINT

6 A 22a \$7 00

The armies of the Russian Czar numbered in all but five hundred and seventeen thousand men, while those sent forward to resist him consisted

1 2 3 4 5 6 7 8 9 0

16 POINT

10 A 44a \$6 00

The battle of Talavera, and the battle of Wagram, under the walls of Vienna, were events of the year that the sad and heart-breaking separation of Napoleon and Josephine took place, by mutual consent, which nearly

1 2 3 4 5 6 7 8 9 0

MANUSCRIPT No 2

24 POINT

6 A 20a \$7 00

Napoleon marched his army into the Dominion early in June, arriving at Wilna, very hungry

16 POINT

10 A 40a \$6 00

Shortly after the burial of Sir John, as soon as arrangements could be completed, the fleet sailed from Corunna toward their home, only to meet with misfortunes on the dark waves.

SKINNER SCRIPT

18 POINT

7 A 22 a \$4 00

The Modern Anti-Everything
September 28th

*Cordially invites you to make a thrilling speech
on prevailing methods of benevolent occupaney
by materials which would be better employed in
Celebrating the Return Home*

12 POINT

10 A 28 a \$3 50

Gentlemen:

*Replying to your kind invitation, I have no hesitation
in affirming my ability to provide the worth of your money, the
same which will be \$3.47 net. Please request your members to
leave absinthe bottles and guns at home.*

Yours sincerely, Adam Glory.

MADISONIAN

10 POINT

5 A 26 a \$2 75

Columbian Yachting Association
Twenty-seventh Midsummer Regatta, Banquet and Dance,
Wednesday, July 27, 1902
Races at eleven o'clock. Banquet at nine thirty
Guest Ticket. Admits to Everything

CURSIVE SCRIPT

A

18 POINT

10 A 40a \$6 00

EXTRA LOWER CASE \$3 25

Hon. Frederick Sherman:

You are cordially invited to be present at the second of a series of entertainments, given under the auspices of the Worcester Tennis Club, at the residence of Mr. Christopher J. Stapleton, No. 64 Elmwood avenue, Lynn, Monday evening, February 2, 1898.

During the evening Brother Quaintly will explain the advantages gained by adopting Wingston's new labor-saving racket, quite recently outlawed by the ladies

The Worcester Tennis Club.

SCRIPT No 9

28 POINT

8 A 20 a \$7 65

Manual for Defaulters
 Questions on the Practice of Incognito
 Route-Book to Leckulationville
 1234567890

22 POINT

12 A 32 a \$6 70

Clothiers of the Sovereign People
 Snipper Cutemwell, Pantaloon Snugfit and Associates
 Contractors for Habiliments for Dudedom
 1234567890

18 POINT

12 A 32 a \$4 95

Sharp Practice Association of Gotham
 Semi-Occasional Distribution of Valuable Unincumbered Property
 Promises Deferred Maketh the Heart Sick

12 POINT

12 A 32 a \$3 40

Caoutchouc's Patented Extension Apparatus
 Useful in Cases of Emergency. Omnibuses and Bedsteads Enlarged at Pleasure
 Further Particulars given on Application
 Patent-rights for Unlimited Territory Granted to Firstcomers

SHEPARD SCRIPT

F

48 POINT

4 A 8 a \$8 00

President ^{and} Secretary
meet Directors May 23

36 POINT

5 A 12 a \$6 75

The National Bank of Silverton
declares Annual Dividend \$580

24 POINT

6 A 18 a \$4 75

Financial Management Reported Competent
to invest the Securities of Stockholders in gilt-
edge Enterprises paying a good percentage 852

18 POINT

8 A 18 a \$3 75

Deposits and Valuable Documents Secured in the very Latest
Improved Fire and Burglar Alarm Vaults. Interest at the
rate of three per cent. allowed on Deposits not exceeding \$8360

CHICAGO SCRIPT

36 POINT

Card Font 3 A 8 a \$6 00
Circular Font 5 A 25 a \$15 30

United States Depository

24 POINT

Card Font 4 A 12 a \$4 70
Circular Font 8 A 36 a \$11 75

The Directors Take Great Pleasure in

18 POINT

Card Font 6 A 16 a \$4 30
Circular Font 12 A 48 a \$10 75

Leather Dealers Protective Association Meeting
will be held on Saturday Evening November

SPINNER SCRIPT

32 POINT

Card Font 3 A 8 a \$4 80
Circular Font 5 A 25 a \$11 75

Convent Garden Promenades

24 POINT

Card Font 4 A 12 a \$4 75
Circular Font 8 A 50 a \$12 50

Ninety Days after Date we Promise to

24 POINT NO 2

Card Font 4 A 12 a \$4 75
Circular Font 8 A 60 a \$12 50

Horticultural Society Reorganization
Silver and Copper Mining Companies

18 POINT

Card Font 6 A 16 a \$4 35
Circular Font 12 A 60 a \$10 00

The Meeting of Societies
will be held Each Month

12 POINT

Card Font 6 A 25 a \$3 25
Circular Font 15 A 75 a \$8 00

In the Prosecution of our Labors
we discover many Persons lying
under trees expecting some Fruit

QUINCY SCRIPT

48 POINT

3 A 6 a \$6 00

We understand the bird
of Freedom though 5678

36 POINT

4 A 9 a \$5 00

So we have the British Lion,
Russian Bear, American Eagle

24 POINT

5 A 16 a \$4 25

It is customary, even at the present time, to
represent Governments by Symbols which have

AUTOGRAPH SCRIPT

24 POINT

7 A 16 a \$8 00

Experience has proven that the
trade Apprentice foreshadows the
Workman just as surely as 123456

PEN TEXT SERIES

36 POINT

3 A 3 A 10 a \$9 00

Lima School Board

30 POINT

3 A 3 A 20 a \$8 40

Insurance Agencies
Walton National Bank

20 POINT

3 A 3 A 20 a \$5 20

Transportation Companies
Great Atlantic and Pacific Railway

18 POINT

4 A 4 A 25 a \$5 00

Specimen of Modern Invention
Invitations, Visiting Cards and Programs

14 POINT

4 A 4 A 25 a \$4 70

Wine Merchant
Imported Fine Brandy
Choice Cigars

12 POINT

6 A 6 A 36 a \$4 35

Manhattan Socials
First Grand Entertainment
Admission Free

10 POINT

8 A 8 A 50 a \$4 20

Moorfield, Marx & Jacobs
Shoes, Boots, Slippers and Appers
1234567890

8 POINT

20 A 60 a \$3 60

Second Grand Spring Opening
Fine Display of Easter Goods for Women
1234567890

NOVELTY SCRIPT

72 POINT

3 A 4 a \$16 00

Rich Child

60 POINT

3 A 5 a \$11 75

Love's Dream

48 POINT

3 A 6 a \$9 00

Famous Battles

36 POINT

4 A 8 a \$7 25

Lithographic Printing

24 POINT

5 A 12 a \$5 25

*Pay to the Order of Thomas Little
Sixteen Kicks with Heavy Boots*

18 POINT

5 A 16 a \$4 00

*It Has Always Been Observed to be a Fact
"Truth Crushed to Earth Shall Rise Again"*

1 2 3 4 5 6 7 8 9 0

PART IV.

ITALIC



DORIC ITALIC

60 POINT

4 A 5 a \$15 50

The END

48 POINT

4 A 5 a \$10 75

DOG Carts

36 POINT

5 A 7 a \$8 75

Crowd LARGE

30 POINT

5 A 7 a \$6 50

SPECIAL Markets

24 POINT

6 A 10 a \$5 00

Cheap VEST

18 POINT

8 A 12 a \$4 50

Money FOUND

12 POINT

10 A 20 a \$4 25

***RECOGNITION
Entertain Nobleman***

10 POINT

12 A 25 a \$4 00

***HOSTILE TRIBES
Prepare Twenty Braves***

8 POINT

15 A 30 a \$3 75

***LECTURING COURSES
Members Securing Tickets
1 2 3 4 5 6 7 8 9 0***

6 POINT

18 A 40 a \$3 50

***AMBITIOUS AUSTRALIAN
Promises Many Business Chances
1 2 3 4 5 6 7 8 9 0***

"POST" OLD STYLE ITALIC

60 POINT

3 A 4 a \$10 50

QUIET HOME
*The clamor and
noise in foundry
and workshop is
forgotten in \$127*

"POST" OLD STYLE ITALIC

48 POINT

3 A 5 a \$7 25

MODERN PRICES
THEORIZED

*No limit being placed
upon the citizens as to
the amount of wealth
amassed by them, \$15*

“POST” OLD STYLE ITALIC

36 POINT

3 A 6 a \$4 75

**HOLIDAY ENGRAVINGS
PHOTOGRAPHS**

*The most attractive place in
our Establishment is beyond
doubt the renowned Picture
Department. Works of Art
make ideal Christmas Gifts
at prices ranging from \$25*

"POST" OLD STYLE ITALIC

30 POINT

4 A 9 a \$4 25

**NECKWEAR & SUSPENDERS
IN GREAT PROFUSION**

We celebrate a sale this morning that will appeal to men of good taste who do not object to saving money; women, too, who intend giving holiday gifts, can purchase them here, and find bargains in which their hearts will delight. They are selling at half price 20

"POST" OLD STYLE ITALIC

24 POINT

5 A 12 a \$3 75

*SALE OF TABLE LINEN
AND MUSLINS TO-DAY*

Buying all our Linen at the lowest possible figures, we can afford to sell at bottom prices. Our stock includes a superb lot of Best Linen, German hemstitched Table Cloths and Napkins. We also carry a grand stock of Linens and Muslins for the bed; sheets and pillow cases of the finest Androsscoggin full bleached muslin at astonishingly low prices. The store will be kept open in the evenings during \$2345

"POST" OLD STYLE ITALIC

18 POINT

7 A 16 a \$3 00

***A MOST COMPLETE LINE OF
FALL SHOES FOR LADIES \$25***

The newest and prettiest styles for women are ready to-day, and every day we are receiving large lots of the most desirable shapes from our factory. Call and see our stock of up-to-date footwear, and you will become convinced that it is the most complete of any store in the city \$26

14 POINT

9 A 20 a \$2 75

***A LARGE SALE OF CLOTHS, ETC.
FOR THE AUTUMN AND WINTER***

Will be opened at 10 o'clock this morning, and continue throughout the week. Our salesmen have been through all the large European cities to secure this stock of fine Clothing which we claim cannot be equaled anywhere in this city. The stock includes Pantaloons, Vests, Dress Coats, Overcoats, etc., of the latest and most stylish cut and pattern, so that the fashionable young men need not hesitate to call and take a look at our display 34

“POST” OLD STYLE ITALIC

12 POINT

10 A 25 a \$2 50

***FRIDAY HOUR SALES COMMENCE
AT NINE O’CLOCK A. M.***

Keeping in touch with the enterprise which is attracting much attention just now in the city, we announce an event which is bound to rank with our “Great Friday Bargain Sales” in importance and powers of attraction. The prices we quote are such as will challenge immediate and enthusiastic attention among the money-savers of this city; but as each item is not to be for sale a minute before nor a minute after the advertised time, it will readily be seen that close attention must be paid \$290

10 POINT

14 A 32 a \$2 50

***THIS IS THE HEADQUARTERS FOR FUR
GOODS OF ALL DESCRIPTION***

Gifts of fur will be acceptable this holiday season, no matter what the thermometer may say: for Furs are so very popular just now that the up-to-date maid or matron will always wear them on proper occasions, whether the weather demands their use or not. These stores are headquarters for good Furs. Prices are the lowest for garments of dependable grades. We have everything desirable, from a plain Scarf of Brook Mink to the most luxurious Jackets and Capes of rich genuine Alaskan Seal or Russian Sable. We also have a splendid variety of Furs for children which prospective buyers will do well to examine before buying elsewhere 24

“POST” OLD STYLE ITALIC

8 POINT

14 A 32 a \$2 25

FIRST DISPLAY TO-DAY OF THIS HANDSOME COLLECTION OF ORIENTAL RUGS

After a very extensive tour through the countries of the Orient, our salesmen have brought back such a collection of some of the rarest kinds of rugs as are not to be seen in any of the other stores in this city. For years we have been in the Oriental Rug business in about the same way as a great many other stores in this country, except that our prices were fair and uniform and not “artistic.” The Rugs were conventional and of as good a quality as we had a right to think people wanted. We had a few of the finer antiques, and antiques were easier to find in those days; but our stock was mostly of a kind that are known as staple: Ghordies, and that sort. Last year for the first time we sent our salesman to Constantinople, and as good fortune would have it, he got there at a time when the new goods were first placed on the market, thereby having the first chance to select therefrom, and to prove \$235

6 POINT

16 A 36 a \$2 00

CAN SEE THROUGH A FOG—A CAMERA WHICH PEERS THROUGH THE DENSEST MIST

In setting this camera for an exposure against fogs, a color screen is used. This is necessary because of the fact that the ordinary fog radiates an excess of blue actinic rays that fog a plate easily. With the seven lenses and the screen, however, the colors of the spectroscop are so blended, neutralized and centered as to make an impression through a dense fog that is more clear cut than a sunlight exposure made through an aromatic lens. From the bow of a steamer moving at half speed through fog this apparatus will show every outline of a vessel steaming half a mile away. It is discovered already that this apparatus has a most remarkable influence on non-actinic lights and colors. For instance, taking up red lights from a photograph on a plate through these lens and screens the apparatus so acts upon it as to set up a fluorescence upon the plate that will give a picture of the objects in the dark room. Yet the plate so acted upon could be left in the dark room indefinitely without becoming fogged. As a discovery of practical value this appeals most strongly to the navies of the world. As a complement to the camera there is a development attachment, by which in a few seconds the picture may be developed and the object thrown on a screen. From this the range finders on a warship might send a broadside into an enemy otherwise \$896

Patent applied for in U. S.
and registered in England

TOURAINE OLD STYLE ITALIC

42 POINT

6 a \$7 25

RESOLUTION
CHANGE

12 POINT

14 A 28 a \$3 25

THE ancient province of Touraine very nearly corresponds to the modern section of Indre et Loire, but in some directions it is rather more extended. It is crossed from east to west by the rapid and sandy stream of the Loire, from a point not far above Amboise to the valley of Fontevrault. Three rapid tributaries of the Loire at this part of its course join the river from the south. Never a stream in so short portion of its course has so much history to tell. Until the end of the sixteenth century this section of France was covered with numerous châteaux, for beside the old feudal towers, whose
**STRENGTH HAD PRESERVED
EACH FROM DECAY MORE IN**

*Peace
Disturber
Rush*

\$65

TOURAINE OLD STYLE ITALIC

Patent applied for in U. S.
and registered in England

38 POINT

4 A 8 a \$5 50

AGROUND
Before the Centuries
Fostled Him

24 POINT

6 A 12 a \$4 50

*Made many new
 abodes in elegant
 style wherein they
 vied in preserving
 merely what was
 picturesque in 32*

*JUNIOR
 POLITICIANS
 BAND*

8 POINT

18 A 36 a \$2 75

VICTOR HUGO

*A quoi bon entendre
 Les oiseaux des bois ?
 L'oiseaux le plus tendre
 Chante dans ta voix.
 Que Dieu montre ou voile
 Les astres des cieux !
 La plus pure étoile
 Brille dans tes yeux.
 Qu'avril renouvelle
 Le jardin en fleur !
 La fleur la plus belle
 Fleurit dans ton cœur.*

*EVERY TOURAINE TOWN
 HAS ITS LEGENDS OF THE
 BLACK Count, the one great
 builder beneath whose hands
 many reaches of the Loire bristled
 with fortresses, each being a step
 toward the dream of his life, the
 greatness of Anjou. His prowess
 as a fighter was early shown in a
 victory at La Conquereux, where
 in spite of Breton pitfalls he led
 his cavalry upon the enemy again
 and again, as the storm wind that
 sweeps down upon a cornfield £4*

Patent applied for in U. S.
and registered in England

TOURAINÉ OLD STYLE ITALIC

30 POINT

5 A 10 a \$5 00

PRESENTING
PRIME NOVELTIES

from Bright

Brain and
Deft Digits

6 POINT

18 A 40 a \$2 50

THE SONG OF THE PRINTER

*Pick and click
Goes Touraine in the stick,
As the artist stands at his case;
His eyes glance quick as his fingers pick
Touraine at a rapid pace;
And one by one as the letters go,
Jobs are piled up steady and slow,
Steady and slow,
But still they grow,
And modern jobs they soon will show,
Beautiful jobs, that without a sound
Appeal to the people all around.*

10 POINT

16 A 32 a \$3 00

SONG OF THE WORLD
AND MAN

18 POINT

10 A 18 a \$4 00

TOURAINÉ
MODEL GRAND
DESIGNS
1902

*O where is the man with such
simple tools can govern this
world of fame? With a print-
ing press, an iron stick, and a
series of Touraine; with ink of
black and paper of white, he'll
bring forth what will live next
doomsday night at 12 o'clock*

*Accents are Made for Numerous
Job letters but they are never put up with
Regular fonts. Special order*

TOURAINÉ OLD STYLE ITALIC

Patent applied for in U. S.
and registered in England

Parisian Millinery

Extraordinary Bargain Sale

If you have money to burn for every cent of it to go for Qu more style, better fabric, per newest materials and choice which appeals to refined tas of these exquisite creations.

EXCLUSIVE DE

Guaranteed to Patro

DAUDET

ALPHONSE
OF
TARASCON

English Edition

JAMES LAURIA
1897

Del

Jean Goujon

Sculpteur

Address, 1462

Touraine, France

Reference

*American Type Founders
Company*

JENSON ITALIC

72 POINT

4 A 5 a \$17 00

Our Reports
were valued
SECURE

60 POINT

4 A 5 a \$12 25

Roman Letters
were invented
MODERN

JENSON ITALIC

54 POINT

4 A 5 a \$10 25

*German printers
used bold Black
Type which was
PRINTED*

48 POINT

4 A 5 a \$7 75

*In early history the
first type Printers
in the Monasteries
RECEIVED*

JENSON ITALIC

42 POINT

4 A 6 a \$7 25

*Italic type is claimed
by historians to be a
good imitation of the
writings of Petrarch*
HISTORICAL

36 POINT

4 A 8 a \$5 50

*The honor of introducing
Italic has been bestowed
on Aldus Manutius, who
used it in classical works*
INTRODUCTION

For Jenson Italic ornamental lower-case, see page 238

JENSON ITALIC

30 POINT

5 A 10 a \$5 00

The original Italic letter was called Venetian or Aldine and was defaced by very strange irregularities in the formation of the slope of the characters

MALFORMATIONS

24 POINT

6 A 15 a \$4 50

Astonishing strides in the designing of Italic type have been made in the last few years. The improvements made in their beauty and the general up-to-date style of their characters reflect a high degree of superiority on the skill of the modern designer

ADVANCEMENTS

For Jenson Italic ornamental lower-case, see page 238

JENSON ITALIC

18 POINT

10 A 25 a \$4 00

Jenson Italic as a display type is a decided novelty. It is distinct in style and striking in character. It is made to the same line as the Jenson Old Style, and its value as a companion letter will be appreciated by printer and advertiser

CHARACTERS

12 POINT

18 A 40 a \$3 25

Makers of Advertisements who formerly recommended the use of old style letters to their clientele will recognize in the Jenson Italic a monotony-breaking substitute, and the reading public will see it and be impressively attracted by advertisements set in this modest and character-giving letter. The aim of writers of advertisements is naturally to attract business to themselves, and that can only be done by attracting the great mass of readers to those who advertise

MAKING PROFITS

The Jenson Italic Ornamental lower-case letters are intended to be used exclusively as final letters. To get the very best results they should be used sparingly in all classes of work. One or two letters properly placed in a job will add to its attractiveness.

*The Jenson Italic Ornamental lower-case letters are made in three characters *n g y* and are cast in all the sizes from 12 Point to 72 Point.*

The Jenson Italic Ornamental lower-case characters are not put up with regular fonts, as all fonts are complete without them. They are furnished at the following prices per font:

12 POINT, 18 POINT AND 24 POINT
EACH 50 CENTS

30 POINT, 36 POINT, 42 POINT, 48 POINT
EACH 75 CENTS

54 POINT, 60 POINT AND 72 POINT
EACH \$1 00

JENSON ITALIC

10 POINT

20 A 45 a \$3 00

THE type made by the American Type Founders' Company is conceded by expert printers to outrank all competitors in its beauty of design, style of finish, and admirable wearing qualities. These three cardinal features are, in themselves, sufficient to recommend them to the vast army of purchasing printers and magazine publishers as a money-saving investment

O Leon, my lover,
Why should you despair,
When Love comes unbidden
With wreaths in his hair?
I love you, my Mona,
Is easy to say
As bird on the tree-top
To sing out his lay.

POINTS TO CONSIDER

8 POINT

20 A 50 a \$2 75

JENSON TYPE.

In Jenson type my printer knows
The height of typographic pose;
The black-faced letters cross the page
Like mummers of some by-gone age
In solemn, sad, funereal rows.

No matter what is said, "it goes,"
Though doggerel verse—puerile prose—
If but its wretched rantings rage
In Jenson type.

Go, foolish rhyme, and dress your woes
In this prevailing garb of those
Who call all well that fits the gauge
Set by the medieval sage—
You too, may conquer, I suppose,
In Jenson type.

NOW to the point that pinches mankind the hardest—the unloosening of the purse-string—and has been the subject of frequent discussions for time immemorial. In figuring on the cost of new type do you regard it as an unnecessary expense or in the light of a good investment to buy the best? If as an investment, suppose a first-class, distinctive style of type costs you a little more than the ordinary and less attractive design, but the returns from the former are double the returns from the latter, which one would you select? You won't hesitate to choose that which is the most profitable.

ARGUMENT AND EXPLANATION

6 POINT

20 A 50 a \$2 50

EVERYTHING that is required in a printing office, from a pair of tweezers to a perfecting press (to say nothing of type) can be supplied on the shortest notice by any Branch House of the American Type Founders' Company. These Branches are all conveniently located throughout the United States for the benefit of the trade and to facilitate the work of supplying the demands made upon us by an appreciative and increasing patronage. Therefore, place your orders with Branch nearest your place of business to insure promptness. A printing office completely supplied with the products of our manufacture is worth far more for use or sale than one made up from the productions of incomplete type foundries.

O Mona, you tease me,
And vex me for aye;
But, Mona, I love you,
Shall love you alway;
I would to the altar
Now lead you a bride,
But love makes me falter
And sway with the tide.

Then bye, oh bye, darling,
For Mona must part
From Leon her lover
With dread in his heart;
Your love is the dewdrop
That dies in the sun,
Good-by, and forever,
With Mona unwon!

INFORMATION FOR THE ENTERPRISING

1234567890

BRADLEY ITALIC

60 POINT

3 A 5 a \$9 00

*Sound Banker
Receive Drafts*

48 POINT

3 A 7 a \$7 25

*Electrical Winder
Novel Time Clock*

36 POINT

4 A 10 a \$5 50

*Monthly Reports Given
Lombard Insurance Co.*

30 POINT

5 A 12 a \$5 00

*Quakers Welcome Visitors
Unique Patriotic Ceremony*

*Bradley Italic Outline, registering with this series, is shown on page 457
See page 453 for specimen in two colors*

BRADLEY ITALIC

24 POINT

6 A 18 a \$4 50

*Fame and fortune never overtake
men in the day of their discontent*

18 POINT

9 A 26 a \$4 00

*The perilous rush of Speculators and the
Adventuresome Miner to the Gold Fields
has been overshadowed by Greater Issues*

15 POINT

12 A 36 a \$3 50

*Couched in tones of unmistakable patriotism, the
Declaration of Independence endowed the people
of the United States with privileges of the most
far-reaching importance to American citizenship*

12 POINT

14 A 40 a \$3 25

*The Laws of Progression have marked the closing of the
Nineteenth Century as the Age of Wonders. With pros-
pects of still greater attainments in the near future, the
best-thinking minds have predicted revolutions in social
and political life that will astonish the most conservative*

10 POINT

14 A 45 a \$3 00

*Pride and humility are rela-
tive terms. They suggest a
comparison of some sort with
an object higher or lower; and
the same mind may be proud*

1 2 3 4 5 6 7 8 9 0

8 POINT

16 A 48 a \$2 75

*Of two minds that possess equal
excellence, which is the noblest:
that which, however high the ex-
cellence attained by it, has some
nobler excellence in view; or that
which thinks only of those who*

1 2 3 4 5 6 7 8 9 0

HARVARD ITALIC

30 POINT

6 A 12 a \$4 25

*PORTLAND BANQUET**Ended in Gayeties**There is considerable pleasant anticipation of the time*

24 POINT

7 A 15 a \$3 50

*HANDSOME TURNOUTS**Old Orchard, August 26**This picturesque resort, famous for its hospitality, its red berries and its pretty girls, opened its gates to-day.*

18 POINT

10 A 18 a \$3 25

*GRAND COACHING PARADE**Greeted with Mighty Cheers**The coaching parade exceeded the most sanguine expectancy of its promoters and called forth some of the highest commendations 85*

HARVARD ITALIC

14 POINT

18 A 26 a \$3 00

FIVE HUNDRED THOUSAND PEOPLE

Cheered one Hour Vociferously

The parade of veterans of the G. A. R. in the city of Cairo, August 25, 1897, was a grand success. Massachusetts division numbered near 3000 men

12 POINT

18 A 30 a \$3 00

BROOKLYN FEMALE ACADEMY BURNED

Destroyed by Fire New Year Day, 1853

Still in the ashes lived the wonted flame, and a new school rose, a stately monument to mark the spot. November 9, 1854, the Packer Collegiate Institute was officially opened

10 POINT

20 A 34 a \$2 75

FASHIONABLE MILLINERY AND DRESS GOODS

Latest Styles from London, Paris and Berlin

Our several departments are fully stocked with fresh merchandise which is matchless in quality, newness, variety and cheapness. It is now high tide of the Holiday Season, and buyers should not 46

9 POINT

20 A 34 a \$2 50

STAGES BETWEEN XYLOGRAPHY AND TYPOGRAPHY

No Question has Aroused Keener Discussion

No question has aroused more interest, or excited keener discussion in the history of printing, than that of the use of movable wooden types as a first stage in the passage from Xylography to Typography. 123456

8 POINT

24 A 36 a \$2 50

HARVARD ITALIC SERIES

Favorably Impress Artists

The beauty of a letter does not necessarily consist in the fancy ornament, but well-proportioned simplicity 86

6 POINT

32 A 42 a \$2 25

DISBAND OUR ORGANIZATION

By Order of Social Members

To secure time for more profitable employment we dissolve the society which in the past has monopolized our thoughts by day and our dreams while we quietly slumbered 123456

DE VINNE ITALIC

PATENTED

72 POINT

4 A 5 a \$19 00

Lost RIG

60 POINT

4 A 5 a \$13 25

RUN Fast

54 POINT

4 A 5 a \$11 25

Read NICE

48 POINT

4 A 5 a \$7 75

BEAR Skins

42 POINT

4 A 6 a \$7 25

Beaver DIVES

36 POINT

5 A 8 a \$6 50

*GRAND Festival**De Vinne Italic Outline, registering with this series, is shown on pages 462 and 463*

DE VINNE ITALIC

PATENTED

30 POINT

6 A 9a \$5 75

BLUSTERING
Destructive Cyclones

24 POINT

8 A 10a \$4 50

FIRING ROCKETS
Distress Signals Answered

18 POINT

10 A 16a \$4 00

WANDERING ARABIANS
Experienced Numerous Hardships

14 POINT

12 A 18a \$3 25

DELIGHTFUL HOLIDAY SEASON
Society Whirlwinds Unceasingly Blowing
Frivolous Dames Dancing

12 POINT

16 A 20a \$3 00

UNDERSTANDS
Thoroughly Mechanical

10 POINT

20 A 26a \$2 75

ARMENIAN MASSACRE
Turkish Cruelty Shows Plainly

8 POINT

22 A 30a \$2 50

CHICAGO WEEKLY NEWS
Universally Pronounced Brilliancy
1234567890

6 POINT

24 A 36a \$2 25

AMERICAN TYPE FOUNDRY
Manufactures Superior Printing Materials
1234567890

GOTHIC ITALIC SERIES

—D-E—

60 POINT No 123

3 A 6 a \$9 60

GRAND Army

48 POINT No 123

4 A 8 a \$7 80

Managers POOR

36 POINT No 123

5 A 10 a \$6 40

UNHAPPY Children

30 POINT No 112

10 A 14 a \$4 50

RENOWNED OFFICERS
Prominent American Senator

20 POINT No 112

18 A 24 a \$3 65

POPULAR DESIGN
Beautiful Specimen

18 POINT No 112

18 A 25 a \$2 80

COURAGEOUS FIGHTERS
Grand Army Encampment

12 POINT No 112

22 A 38 a \$2 50

HARMONIOUS COMBINATIONS
Fancy Typographic Decoration

10 POINT No 112

30 A 42 a \$2 60

UNPRECEDENTED INDUCEMENTS
Extraordinary Bargains Extended

8 POINT No 112

36 A 52 a \$2 60

PLEASANT STEAMBOAT EXCURSIONS
Lovely Sights Mid Picturesque Valleys
1234567890

6 POINT No 113

30 A 60 a \$2 40

DISTINGUISHED AMERICAN STATESMEN
Berlin Historical and Poetical Association
1234567890

COMBINATION ITALIC GOTHIC

48 POINT NO 150

4 A \$4 00

DEALER 1 PAGE

36 POINT NO 149

6 A \$3 40

PLEASING CONCERTS

24 POINT NO 138

8 A \$2 50

DISTRICT BOARD ELECTED

24 POINT NO 137

10 A \$2 25

HANDLING STOLEN OVERSHOES

18 POINT NO 136

14 A \$2 00

**KNOWLEDGE
CROUPERS BROKEN**

12 POINT NO 135

16 A \$1 40

**STRONG ATHLETES
ASSOCIATIONS JUBILANT**

12 POINT NO 134

20 A \$1 40

**HANDSOME STRUCTURE
BEAUTIFUL MASONIC TEMPLES**

12 POINT NO 133

24 A \$1 40

**FOREIGNERS IMPORTING
AMERICAN STEAMSHIPS CONTESTED**

6 POINT NO 132

30 A \$1 35

**CONGRESSIONAL QUESTIONS
REPRESENTING NORTHERN MEMBERSHIP
1 2 3 4 5 6 7 8 9 0**

6 POINT NO 131

40 A \$1 35

**DELIGHTFUL DECEMBER SKATING
BANQUET OF THE CANADIAN SNOWSHOE ASSOCIATION
1 2 3 4 5 6 7 8 9 0**

RONALDSON TITLE SLOPE

36 POINT

5 A 8 a \$6 00

CHILD *Spankers*

30 POINT

6 A 10 a \$5 25

GRUMBLING
Jawtickler Curatives

24 POINT

8 A 14 a \$4 50

TEXAN STEERS
Cowboy Lassos Electrified

18 POINT

12 A 22 a \$4 15

POCKET BATTERY
Thoroughly Paralyzes Pickpockets

12 POINT

20 A 40 a \$3 55

ELECTRICAL
Burglar Alarm Hinges
Chicken Coops

10 POINT

22 A 45 a \$3 35

RAPID TRANSIT
Fleeting Landscape Scene
Passing Glimpse

8 POINT

25 A 50 a \$3 15

CRIME PUNISHED
Appliances to Produce Torture
Suitable to the Offense
1 2 3 4 5 6 7 8 9 0

6 POINT

30 A 60 a \$3 00

DYNAMO & COMPANY
Contrivers of Electrical Machinery
Adapted to Various Purposes
1 2 3 4 5 6 7 8 9 0

ALFERETA SERIES

36 POINT

4 A 8 a \$6 00

National Candidate
Popular Heroes

30 POINT

5 A 10 a \$5 25

Musical Festival Opened
Orchestral Exercises

24 POINT

6 A 12 a \$4 50

Photographic Views Reproduced
Improved Lenses 43
Amateurs Purchasing Material

18 POINT

8 A 16 a \$3 50

Havana Mercantile Insurance Company
Capital Stock \$2580
Conscientious Representatives Employed

12 POINT

8 A 30 a \$2 75

Philosophical Association Distributing Patriotic Literature
History of the United States 1786
Declaration of Independence and other Interesting Papers

LACLEDE SERIES

72 POINT

3 A 5 a \$12 00

Monumental

60 POINT

3 A 6 a \$10 00

Broken Dishes

48 POINT

4 A 7 a \$8 00

Country Residence

36 POINT

4 A 9 a \$6 25

Unique Pictures Framed

24 POINT

5 A 14 a \$4 00

*Industrious
Western Farmer*

18 POINT

5 A 18 a \$3 25

*Enchantment
Handsome Decoration*

12 POINT

7 A 24 a \$3 00

*Financial Speculation
Renowned European Negotiators
1 2 3 4 5 6 7 8 9 0*

10 POINT

9 A 30 a \$2 75

*Journalistic Conventions
Neapolitan Newspapers Represented
1 2 3 4 5 6 7 8 9 0*

LIVERMORE SERIES

PATENTED

60 POINT

3 A 4 a \$8 25

Denouncement

48 POINT

3 A 6 a \$6 25

Famous Workmen

36 POINT

4 A 10 a \$5 25

Determined Advertiser

30 POINT

5 A 12 a \$4 75

Reward Honest Merchants

24 POINT

6 A 18 a \$4 25

*Brave Chaplain
Receives Medal*

18 POINT

9 A 28 a \$3 75

*Wonderful Cavalcade
Marching Homeward*

12 POINT

15 A 50 a \$3 25

*Youthful Juveniles Rehearse
Dramatic Elocution Admired*

10 POINT

15 A 55 a \$3 00

*Patriotic Orators Arouse Natives
Enthusiastic Countrymen Prepare
Great Midsummer Demonstration*

8 POINT

15 A 55 a \$2 75

*Sensational News of Great Victories
and Military Achievements Eagerly
Devoured by all Patriotic Admirers*

6 POINT

15 A 60 a \$2 50

*Conservatives and Radicals Join Hands
for the Sole Purpose of Introducing Peace
on Conditions Acceptable to both Countries*

1 2 3 4 5 6 7 8 9 0

1 2 3 4 5 6 7 8 9 0

The five larger sizes register with Livermore Outline shown on page 459

See page 452 for specimen in two colors

BOLDFACE ITALIC

—A-E—

* 48 POINT NO 23

4 A 6 a \$7 00

SURE *Bounty*

* 36 POINT NO 22

5 A 7 a \$5 50

Southern *CHEER*

30 POINT NO 120

6 A 12 a \$4 55

AMERICAN *Knowledge*

24 POINT NO 120

10 A 20 a \$4 55

HONEST PROCLAMATION
Cuban Insurgents Dissatisfied

18 POINT NO 120

12 A 24 a \$3 90

PICKPOCKETS
Hunting Steamer

12 POINT NO 120

12 A 24 a \$2 65

OCEAN STEAMER
Flagship New York

11 POINT NO 120

18 A 36 a \$3 05

MEXICAN SOLDIERS
Raised Window Curtain

10 POINT NO 120

18 A 36 a \$2 90

GOVERNMENT BOND
Relating many Incidents

9 POINT NO 120

24 A 48 a \$2 95

REVENUE COMMISSIONER
United States Treasury Notes

8 POINT NO 120

24 A 48 a \$3 00

DESPERATE ENCOUNTER
Volunteers and Spanish Troops

7 POINT NO 120

24 A 48 a \$2 55

PERFECTLY WELL SATISFIED
With Constitutional Amendments

6 POINT NO 120

24 A 48 a \$2 25

RESTORING PUBLIC CONFIDENCE
Delay Republican National Convention

1234567890

1234567890

BOLDFACE ITALIC

36 POINT NO 15

6 A 10a \$8 52

***FLOAT** Backward*

30 POINT NO 15

6 A 10a \$4 76

*Healthful **SALT BATH***

24 POINT NO 15

8 A 20a \$4 40

***SEA SERPENT GAMBOLS**
Entertains Boisterous Multitude*

* 5½ POINT NO 27

24 A 38a \$2 25

***SHOWING DILAPIDATED PURSE**
And Small Moiety of Change Remaining
1234567890*

5 POINT NO 15

24 A 44a \$2 70

***THEN MEANDERS BACK TO TURMOIL**
Assuaged by Anticipations of Next Vacation
1234567890*

FULL FACE ITALIC No 123

12 POINT

12 A 24a \$2 65

***DOWN THE LITTLE WORN PATH**
Several Breakneck Contortions Performed*

11 POINT

18 A 36a \$3 30

***STOUT STRANGERS**
Prospecting For Gold*

10 POINT

18 A 36a \$3 20

***CELEBRATED MAN**
Exceedingly Heartless*

9 POINT

18 A 36a \$2 65

***TWELVE OLD TIGERS**
Escaped Alone at Midnight*

8 POINT

18 A 36a \$2 60

***LABOR DAY PARADES**
Marching To Sweet Music*

6 POINT

24 A 48a \$2 60

***WIND BLOWETH STRONGLY**
Down the Mossgrown Woodpath
1234567890*

5½ POINT

24 A 48a \$2 65

***WHERE RIVER GENTLY FLOWS**
Angry Waves Dashing Madly Past
1234567890*

INCLINED GOTHIC

24 POINT

8 A \$3 00

JUBILEE SONG

18 POINT

12 A \$2 50

MUSICAL CHILDREN

16 POINT

14 A \$2 25

**MASSACHUSETTS
EDITORIAL ASSOCIATION**

12 POINT

20 A \$2 00

**FAMOUS STATESMEN
ASSEMBLED IN CONFERENCE**

10 POINT

24 A \$1 75

**NUMEROUS PEOPLE
WITNESS THE GRAND NAVAL DISPLAY**

8 POINT

26 A \$1 50

**EXTRAORDINARY ATTRACTION
PERFORMING ELEPHANT BATHING IN RESERVOIR**

6 POINT No 7

28 A \$1 25

**MOUNT WASHINGTON
VIEWED BY EXCURSIONISTS**

6 POINT No 6

30 A \$1 25

**INDEPENDENT CITIZENS
FAVORABLE TO RAPID TRANSIT**

6 POINT No 5

32 A \$1 25

**NAVIGATION SUSPENDED
BETWEEN TWILIGHT AND MIDNIGHT
1 2 3 4 5 6 7 8 9 0**

6 POINT No 4

34 A \$1 25

**CIRCUMSTANTIAL EVIDENCE
PRODUCED BY THE DISTRICT ATTORNEY
1 2 3 4 5 6 7 8 9 0**

GOTHIC ITALIC EXTRA CONDENSED

42 POINT

8 A 10 a \$7 00

CONTAMINATE *Correspondents*

36 POINT

9 A 12 a \$6 00

Blackened Character *WHITEWASHER*

30 POINT

10 A 14 a \$5 00

MEDDLESOME MANNER *Lively Expert Player*

24 POINT

12 A 16 a \$4 25

Characteristic Charities *PROTESTED IN EARNEST*

20 POINT

15 A 20 a \$4 00

DELICACIES *Devoured With*

16 POINT

18 A 24 a \$3 75

Selections From *BEST AUTHOR*

12 POINT

20 A 30 a \$3 40

COLLECTING ANTIQUITIES
Quaint and Curious Old Specimens

10 POINT

24 A 36 a \$3 25

PRINCELY SALARY PAID
Superintendent Who has Responsibility

8 POINT

26 A 38 a \$3 00

SILVER MOON RESTAURANT
A Famous Western Hostelry in Days Gone By
1 2 3 4 5 6 7 8 9 0

6 POINT

28 A 40 a \$2 50

PECULIAR PRONUNCIATION CONDEMNED
Plain Simple Style of Conversation Much More Preferable
1 2 3 4 5 6 7 8 9 0

INCLINED ANTIQUE

12 POINT

20 A 30 a \$3 50

BUILDING STONE
Fine Residence

10 POINT

25 A 40 a \$3 35

DRAW AND COMPANY
Merchandise Jobbers

8 POINT

30 A 50 a \$3 15

SEASIDE PROMENADE
Pleasant Moonlight Recreation
1 2 3 4 5 6 7 8 9 0

6 POINT

30 A 50 a \$2 75

NOTEWORTHY OCCURRENCES
Real Conflicts in the Warfare of Life
1 2 3 4 5 6 7 8 9 0

CIRCULAR GOTHIC No 120

24 POINT

Card Font 10 A 20 a \$3 20
Circular Font 10 A 40 a \$4 90

KITCHEN OUTFITS
Latest Improvement
1234567890

10 POINT

Card Font 24 A 48 a \$2 45
Circular Font 24 A 144 a \$5 15

EXQUISITE PERSIAN WEAVINGS
Oriental Hangings and Draperies

8 POINT

Card Font 24 A 48 a \$2 10
Circular Font 24 A 144 a \$4 40

HOUSEHOLD LABOR-SAVING DEVICES
Everything for the Economic Housewife

ANNOUNCEMENT

To Our Patrons

WE desire to call the attention of our patrons to the several new departments just added to our stores in which they will find a unique variety of

Household Furniture

which we claim to be the most extensive ever put on exhibition and offered for sale. The assortment includes everything needed by the modern housekeeper.

RONALDSON BROS.

12 POINT

Card Font 18 A 36 a \$2 45
Circular Font 18 A 108 a \$5 05

TAPESTRY, ART SQUARES
Carpets Unexcelled in Price

18 POINT

Card Font 12 A 24 a \$2 65
Circular Font 12 A 48 a \$4 05

UPHOLSTERY GOODS
Lace Curtains, Fixtures

Above series also shown on page 163.

GOTHIC ITALIC No 124

24 POINT

10 A \$1 15 10 A 20 a \$3 20

MADAME TATTLERS BOARDING SCHOOL
Big Turkey Gobbler Stuffed WITH OYSTERS

18 POINT

12 A \$0 95 12 A 24 a \$2 95

SOUTH AMERICAN SILVER MINING COMPANIES
Competency Acquired by Distributing GOLD COIN

12 POINT

18 A \$0 90 18 A 36 a \$2 55

MORPHINE EVENTUALLY WARRANTED TO KILL THE USERS
General Views of the Confirmed Loafers Do-NOTHING SOCIETY

10 POINT

24 A \$0 85 24 A 48 a \$2 65

GIVING GOOD PRONUNCIATIONS
Superintendents are RESPONSIBLE

8 POINT

24 A \$0 70 24 A 48 a \$2 20

REPRESENTING BUSINESS INTERESTS
Being Produced by GENERAL ASSEMBLIES

6 POINT

32 A \$0 75 32 A 64 a \$2 25

BANQUET OF THE CANADIAN SNOW-SHOE CLUB
Scenery Along the Boulevard near FORT SHERIDAN
 1234567890

5 POINT ON 6 POINT 32 A \$0 85 32 A 64 a \$1 95

HIS CONVICTION UPON CIRCUMSTANTIAL TESTIMONY
The Breadth and Depth of Social FASHION UPON SOCIETIES
 1234567890

Small Caps not sent unless expressly ordered

GOTHIC SLOPE No 20

24 POINT

10 A 22 a \$3 50

QUICKSAND
Wrecking Mountain

18 POINT

14 A 32 a \$3 25

TYPOGRAPHICAL
Government Bombshells

12 POINT

20 A 40 a \$3 00

YOUNGEST DOMESTIC
Hustling Graduates are Preparing

10 POINT

22 A 50 a \$2 75

CONVERTING RASCALITY
Progressive and Healthiest Orations

8 POINT

28 A 56 a \$2 50

GENEROUS AMERICAN WORKMEN
Honorably Discharged United States General
 1 2 3 4 5 6 7 8 9 0

6 POINT

30 A 60 a \$2 25

HANDLING MORTGAGED PROPERTY
Seldom Encounter California Mountain Driveways
 1 2 3 4 5 6 7 8 9 0

REGAL ITALIC

36 POINT

4 A 8 a \$6 50

HIRE *Domestics*

30 POINT

5 A 10 a \$6 00

Emblematic *CORDS*

24 POINT

6 A 12 a \$5 25

ACHIEVEMENT
Meritorious Instruction

18 POINT

7 A 14 a \$4 50

MONROE DOCTRINE
Historic Document Published

14 POINT

9 A 18 a \$4 20

LEARNED EDUCATORS
Conclusive Academical Examination

12 POINT

12 A 24 a \$4 00

GYMNASIUM
Masculine Exerciser

10 POINT

14 A 28 a \$3 50

ORGANIZATION
Universal Peace Societies

8 POINT

18 A 36 a \$3 00

SURGICAL RECORDS
Scientific Theories Examined
1 2 3 4 5 6 7 8 9 0

6 POINT

24 A 48 a \$2 50

INFORMATION BUREAU
Valuable Services Rendered Citizens
1 2 3 4 5 6 7 8 9 0

VICTORIA ITALIC

24 POINT NO 1

8 A \$3 75

EXCURSIONIST

24 POINT NO 2

8 A \$3 25

SEVERE STORMS

18 POINT NO 1

12 A \$3 25

MIDNIGHT RAMBLE

18 POINT NO 2

12 A \$2 75

SUBURBAN RESIDENCE

12 POINT NO 1

16 A \$2 50

DECOROUS SPINSTERS
MUTUAL ADORATION SOCIETY

12 POINT NO 2

16 A \$2 25

LUDICROUS AND ANNOYING
SUDDEN BURSTING OF PANTALOONS

12 POINT NO 3

18 A \$2 00

FLOWER PLANTS
GERANIUM ADMIRE

6 POINT NO 1

30 A \$2 50

ROYAL VISITORS
SALUTING THE FLAGSHIP

6 POINT NO 2

30 A \$2 25

HUMOROUS ANECDOTES
GUARDED SECRETS OVERHEARD

6 POINT NO 3

30 A \$2 00

ROBINSON CRUSOE OUTDONE
HISTORY OF SINBAD THE MARINER

6 POINT NO 4

36 A \$2 00

HARMLESS SIMPLETONS RAMPANT
VICTIMS OF CHEAP AND TRASHY NOVELS

6 POINT NO 5

36 A \$2 00

CYCLONIC WINDS RAGING FIERCELY
DESTRUCTIVE STORM DEMOLISHING PROPERTY

1 2 3 4 5 6 7 8 9 0

1 2 3 4 5 6 7 8 9 0

LINE STRICTLY ACCURATE SIGN

CUSHING ITALIC

24 POINT

8 A 15 a \$4 50

RULES GOVERNING BOSTON SHOUTER VOTING CONTEST

Non-compliance will invalidate all coupons, so read the rules slowly

12 POINT

20 A 50 a \$3 94

NAME and address must be plainly written in the spaces shown in the coupon. A nom-de-plume or an alias will not answer, nor will the location of a cow pasture be acceptable. In guessing the height of the house it must be considered that in addition to a French roof there is also a mortgage on it. The taxes, insurance and water rates for 1898-99 are unpaid and will of course make it higher. See that your coupons are directed SHOUTER SECOND-HAND HOUSE CONTEST EDITOR

Given Away

The Boston Shouter will give a fine brick house to the man or woman correctly guessing its height, and in accordance therewith I submit as follows :

Height, over-all, from street level, Points

Name, in typewriter,

Address, in confidence,

10 POINT

28 A 80 a \$3 80

NO COUPONS SENT US LATER THAN MARCH 25 WILL COUNT

And no packages will be received from messengers. The result of the contest will be made public in a special edition which will be issued a few moments after the last vote has been counted. Our bulletin boards also will be utilized. Watch them

CUSHING ITALIC

18 POINT

10 A 20 a \$4 00

ROXBURY HORSE GUARDS PICNIC
Nantasket Beach
Monday Afternoon, October 28

15 POINT

15 A 25 a \$3 50

The annual picnic this year will be held at the new reservation at Nantasket Beach. Special open cars will be available for the transportation of picnickers and their cousins from sunrise until the approach of dinner time. A special feature of the occasion will be the singing of some verses which have been set to music by Marie Grosse, and of which the opening verses are appended. Music will be by tambourine

8 POINT

28 A 80 a \$3 00

THE DEAR OLD TIN CANTEEN

*I tell you, Jim, it ain't no use,
 A soldier can't forget,
 Those bloody scenes are just as fresh
 As on the day we met;
 But all the relics of the war,
 The broken sword, I ween,
 E'en knapsack old, there is none like
 The dear old tin canteen.*

*You recollect as well as I
 The hunger and the thirst,
 The mad career of horse and men,
 Where rebel shells had burst;
 But after all, you gray old vet,
 The best remembered scene
 Was when we stole a chance to drink
 From out the old canteen.*

6 POINT

28 A 80 a \$2 60

SPECIAL CAR FOR MOROSE PEOPLE will be run via Quincy and Milton before sunrise. Those who do not care for sociability, or for the exhilarating daylight ride over the road at a later hour, may take this car. Ample opportunities for services of a religious nature, to be conducted by the motoneer, will be afforded during the trip

CASLON OLD STYLE ITALIC No 71

This series was cut A. D. 1722

48 POINT

3 A 5a \$6 05

*REFORMS**Honorable Intention*

22 POINT

8 A 18a \$3 15

*MUNICIPAL TAXPAYERS**The impartial observer of the subject quickly discovers that a Movement to Push the Growth of the Town is felt*

18 POINT

10 A 28a \$3 40

*ELECTRIC LIGHT FRANCHISE**Important Privileges were granted by the Board of Aldermen, who did not hesitate to surrender without Restraint one of the most valuable Rights in the City to a Syndicate*

30 POINT

5 A 10a \$3 60

*OLD COLORIST**Chromatic Sketchings Exhibited
Beautiful Design*

CASLON OLD STYLE ITALIC No 71

42 POINT

4 A 7 a \$5 15

DEFINING
Agrarian Legislation

24 POINT

6 A 14 a \$3 35

DECISIONS RENDERED
Sanitary Authorities refused the
overtures of the property owners
for severe Quarantine Measures

14 POINT

18 A 52 a \$5 00

STATE AND COUNTY GOVERNMENTS
We have a system of Local Government equal to any
which exists in Europe. The Legislatures have power
little short of Home Rule, and the Townships exercise
considerable Legislative Rights under various charters
that are augmented in accordance with the development

36 POINT

4 A 8 a \$4 60

ENORMOUS
Monetary Consideration
Short Debate

OLD STYLE ITALIC No 79

36 POINT

4 A 8 a \$4 25

Boston & Denver
MINING SOURCE
Company

18 POINT

10 A 24 a \$3 50

Dear Investor

To those about to follow the pursuit of mining, or to any persons already connected with that industry, we can offer services and information as to the locating of valuable sites that we can guarantee resourceful. We will call upon you, if such be your desire

Hoping truly that

UNEEDA G. MINE

10 POINT

28 A 80 a \$3 51

IMPORTANT NOTICE — If you do not need a low-priced gold mine, some of your friends might have a desire to own one, and if you will kindly place us in communication with them a most substantial benefit will certainly result to us

 OLD STYLE ITALIC No 79

6 POINT

28 A 80 a \$2 67

THE NEWS IS PUBLISHED IN THE INTERESTS OF ITS STOCKHOLDERS
Daily Edition Guaranteed, 2,587,240 Paid Subscribers

24 POINT

6 A 14 a \$3 60

Editorial Department
LUZON MORNING NEWS
Confidential

12 POINT

20 A 50 a \$3 84

Dreaded Poet

*Regretfully and hesitatingly we return your hastily
 penned effusion. To say that it is poor might offend,
 but why? It is not so very bad—to be poor. Some
 people that we might name are dead, but they rashly
 delivered their little effort personally. You may not
 wish to make another submission. We hope you don't*

*Conditionally yours**THE EDITOR*

14 POINT

16 A 36 a \$3 56

CONTRIBUTORS MUST

8 POINT

28 A 80 a \$2 94

Give Name and Address When forwarding contributions, not as
 an indication of good faith, but because we demand it. Also enclose postage to cover
 the expense of returning the rejected manuscript. These simple rules are imperative

OLD STYLE No 83 ITALIC

42 POINT

3 A 6 a \$6 00

MILLINERY

10 POINT

20 A 40 a \$2 40

*On SATURDAY April 30, 1997,
we will place on sale the exquisite
creations in Spring Millinery that
have been of late in our competitors'
window, you have*

22 POINT

8 A 16 a \$3 80

A CORDIAL Invitation to go

12 POINT

20 A 40 a \$3 05

*over there and inspect the beautiful
designs and material of which they
are made; pick out the hat you want
to wear out doors next*

30 POINT

5 A 10 a \$5 00

EASTER Sunday

8 POINT

25 A 75 a \$2 95

*Many metropolitan printers make use of this
series for fine brochure work and with it
obtain an effect that is unique and beautiful.
The big dailies are also users to a large
extent in their special lines of advertising.*

24 POINT

8 A 16 a \$4 25

The AMERICAN TYPE

 OLD STYLE No 83 ITALIC

42 POINT

3 A 6 a \$6 00

Grand Opening 4

18 POINT

10 A 20 a \$3 10

OUR APRIL CIRCULAR *Describing nearly Three Million Dollars of choice Municipal and Corporation Bonds, desirable investments for funds of National, State and Savings Banks, Trustees of Estates, Trust Funds and Private Individuals, will be mailed on application. To secure Promptness enclose certified check.*

6 POINT

25 A 75 a \$2 40

The six point size of the Old Style 83 Italic is well adapted to descriptive paragraphs on catalogue and advertising work, and looks well in blanks where the space will not admit of a larger letter. This entire series of italic is suitable for all classes of commercial printing. Stationery printed with this type, when handled by competent men, draws expressions of admiration from the discriminating and particular.

24 POINT

8 A 16 a \$4 25

FOUNDERS COMPANY

FRENCH OLD STYLE No 2 ITALIC

14 POINT ELZEVIR ITALIC A

16A 36a \$3 90

TO THE MESSIEURS ELZEVIR

I am indebted to you, and more so, perhaps, than you may imagine. The honor of Roman citizenship is even less than the benefit you have co 1234567890

12 POINT

16A 40a \$3 50

TO THE MESSIEURS ELZEVIR

I am indebted to you, and more so, perhaps, than you imagine. The honor of Roman citizenship is even less than the benefit you have conferred on me. For what do you think was this honor in comparison with that of being 1234567890

10 POINT

20A 50a \$3 00

TO THE MESSIEURS ELZEVIR

I am indebted to you, and more so, perhaps, than you imagine. The honor of Roman citizenship is even less than the benefit you have conferred on me. For what do you think was this honor in comparison with that of being placed in the ranks with your authors? It is to rank with the consuls and senators of Rome; it is to be made fell 1234567890

8 POINT

24A 60a \$2 75

TO THE MESSIEURS ELZEVIR

I am indebted to you, and more so, perhaps, than you imagine. The honor of Roman citizenship is even less than the benefit you have conferred on me. For what do you think was this honor in comparison with that of being placed in the ranks with your authors? It is to rank with the consuls and senators of Rome: it is to be made fellow with the Sallusts and Ciceros? What glory it is to say, I am a member of this immortal republic: 1234567

7 POINT

24A 60a \$2 50

TO MESSIEURS ELZEVIR

I am indebted to you, and more so, perhaps, than you imagine. The honor of Roman citizenship is less than the benefit you have conferred on me. For what do you think was this honor in comparison with that of being placed in 1234567890

6 POINT

20A 45a \$2 25

TO THE MESSIEURS ELZEVIR

I am indebted to you, and more so, perhaps, than you imagine. The honor of Roman citizenship is even less than the benefit you have conferred on me. For what do you think was this honor in comparison with that of being placed in the ranks with your authors? It is to rank with the consuls and senators of Rome: it is to be made fel 1234567890

CAXTON OLD STYLE ITALIC €



12 POINT

18A 100 a \$5 70

*SOME UNUSUAL VALUES FOR
TO-DAY—TAILOR-MADE SUITS*

*All the Garments are handsomely
made in the latest styles, and sold
at most reasonable prices \$12.50*

8 POINT

32 A 200 a \$8 15

*THIS UNIQUE AND MODERN
EXHIBITION IS UNDER THE
AUSPICES OF THE PEN AND
PENCIL CLUB OF NEWPORT*

*The collection gives some idea
of what American artists have
done in this line, as nearly all
of the wash drawings are repro-
ductions of work done by noted
Americans. The drawings are
copies of designs from some of
the largest and best decorated
buildings in the United States,
including the Appellate Court-
house, New York, the residence
of G. W. C. Mount, Philadelphia,
the St. John's Church, Detroit,
and the Congressional Library*

6 POINT

32 A 200 a \$6 70

SPRING IN BRADFORDVILLE.

*Spring has come to Bradfordville—
Trees are blossom-dressed;
Flowers bloomin' on the hill
Look their purtiest.
Winmenfolks a-cleanin' house
Like they know their biz;
Brockway's sody fountain, too,
Has begun to fizz!*

*Got the tiredness in my bones—
Can't do much but rest
Until mealtime comes aroun'—
Then I do my best.
If I git much tireder, though—
Tell you how it is,
I'll get Brockway jest to put
A wink in my Fizz!*



10 POINT

24 A 140 a \$6 65

*BICYCLE OUTFITS FOR THE LADIES
LATEST STYLES, AND ALL COLORS*

*Continuation of our great sale of Ladies'
Bicycle Clothing, made from the latest
patterns. This stock includes Bloomers,
Divided Skirts and Short Skirts \$20.57*

LAW ITALIC

30 POINT NO 42

7 A 14 a \$4 50

REGULATION FOR VOTERS
Citizens must have Paid Taxes

24 POINT NO 42

8 A 20 a \$3 60

HIGH COURT OF FINAL APPEALS
Right of Appeal from the Lower Court
is hereby Extended to any Defendant

18 POINT NO 122

10 A 28 a \$3 30

WELCOMED RESTRICTIVE PROCEEDINGS
Notice is hereby given that Imperative Orders
were Issued to rigidly Enforce the Curfew Law

12 POINT NO 122

14 A 42 a \$3 00

HONORARY CERTIFICATE
This is to certify that Robert
Jay Nevertail is an Honorary
Member of the Noble Society
to facilitate Corner Lounging

10 POINT NO 122

20 A 52 a \$2 80

SUMMONS AGAINST A MASTER
You are hereby commanded to take
the body of Ephraim Lazy, if he can
be found in this County, and bring
him before me, Jonathan Resolute, a
Justice of the Peace, to be sentenced

8 POINT NO 122

25 A 70 a \$2 85

AN INDENTURE OF APPRENTICESHIP
This Indenture witnesseth: That Marion
Highstrung with and by the consent of her
mother, as her next friend, has bound and
put herself apprentice to Arabella Lofty, to
learn the art of Extravagant Housekeeping

1 2 3 4 5 6 7 8 9 0

6 POINT NO 122

25 A 70 a \$2 45

COMMONWEALTH VERSUS JOSEPH SLOWPAY
Whereas Joseph Slowpay, of Indolent Township, in
this County, hath failed to pay his Dog Taxes for
one year, according to law, therefore we command
that you summon the above said Joseph Slowpay to
appear before us and show ample and satisfactory
cause why he hath failed to make such payments

1 2 3 4 5 6 7 8 9 0

LAW ITALIC No 120

12 POINT

Card Font 9 A 25 a \$2 10
Circular Font 18 A 100 a \$6 60

Said Company furthermore agrees to make good to the assured Persons all Damages from Water which is the Result of a Fire in the Adjoining Building, provided that Precaution was Taken

10 POINT

Card Font 12 A 35 a \$2 30
Circular Font 24 A 140 a \$7 40

Pursuant to Section 2935 of the Code of this State, we hereby furnish you with the List of Persons subject to Taxation and Valuation required by Law to be yearly ascertained, together with the Amounts paid by them

8 POINT

Card Font 16 A 50 a \$2 50
Circular Font 32 A 200 a \$8 05

In case of Violation of any of the foregoing Conditions upon which the Policy is issued and accepted, as mentioned before, this Policy shall become Void

1 2 3 4 5 6 7 8 9 0

6 POINT

Card Font 16 A 50 a \$2 00
Circular Font 32 A 200 a \$6 70

This Agreement is made and accepted subject to the Foregoing Conditions and Stipulations, together with such Provisions as may be added thereto, and no Officer of the Company shall have Power to Cancel the Regulation

1 2 3 4 5 6 7 8 9 0

COPPER ALLOY FINE-DOT LEADERS

These are used as a substitute for Dotted Brass Rule, and save the time spent in justification. Made on 6, 7, 8, 9, 10, 11 and 12 Point bodies. When ordering, state the type (if our make) they are required to line with, and send cap "H" or lower-case "m." The following examples show Fine-Dot Leaders lining with 8 Point and 10 Point Law Italic No. 120 and 8 Point and 10 Point Law Italic No. 122:

8 POINT LAW ITALIC NO 120

In combination with 8 Point Fine-Dot Leaders

*A Court of.....will
be held on the.....day of
.....in the city of.....*

10 POINT LAW ITALIC NO 120

In combination with 10 Point Fine-Dot Leaders

*You.....are
commanded by.....
.....to take before*

8 POINT LAW ITALIC NO 122

In combination with 8 Point Fine-Dot Leaders

*In consideration of \$.....and
.....cents, we hereby agree to lease
the building on premises.....*

10 POINT LAW ITALIC NO 122

In combination with 10 Point Fine-Dot Leaders

*Executed this.....day of.....
190.....in.....County of
.....in presence of the*

Put up in 5-lb. fonts at the following prices per lb.:

6 Point Per pound \$0 64
7 Point Per pound 56
8 Point Per pound 52

9 Point Per pound \$0 48
10 Point Per pound 46

11 Point Per pound \$0 44
12 Point Per pound 42

TRISTAN ITALIC

30 POINT

4 A 25 a \$6 15

Exquisite and Charming Spring Styles

24 POINT

5 A 30 a \$5 60

*Designed by the Celebrated Artists of the World
Neapolitan Swandown & Brother*

10 POINT

10 A 50 a \$3 60

*All our Dress Patterns were bought before the advance in price.
We are therefore enabled to offer them at lower figures than usual.
This is an opportunity to get up-to-date Patterns at a small cost*

12 POINT

10 A 50 a \$4 35

*In the Dress Goods Section are all high-quality but low-priced stuffs
for Spring and Summer Wear, such as: Homespuns, Serges, Plaids
and Challies, 18c. to 75c. the yard. It is here that Bargains abound*

8 POINT

12 A 60 a \$3 60

*All the Goods that properly belong to this Section are the fullest of Full
Value; the kind of dress goods through which dealers take advantage of you.
We hear of \$1 stuff for 50c. The same as we have sold for 25c. When
you buy these "bargains" look at the goods as well as the advertisement*

18 POINT

6 A 40 a \$5 25

*Handsome and Enchanting Results are Easily Obtained
Fashionable 20th Century Maidens*

ORNAMENTAL CAPITALS

24 POINT 5 A \$1 90

E H G H J

30 POINT 4 A \$1 85

A B C D

18 POINT 6 A \$1 50

K L M N O

MODERN JOBGING LETTER



The Fashionable Styles
used by leading Print-
ers and Publishers all
over the world *o o*

BINNER SERIES

72 POINT

4 A 5 a \$17 00

BRICK
Hue Golf
Shoes

60 POINT

4 A 5 a \$12 25

CINDER
Path Road
Bicycle

BINNER SERIES

54 POINT

4 A 5 a \$10 25

**BEST HIGH
Price Onions**

48 POINT

4 A 5 a \$7 75

**INDIAN MEAL
Flour and Hams**

36 POINT

5 A 8 a \$5 50

**COMIC SKETCH
With Lead Pencils
Not Traced**

Binner Open, registering with this series, is shown on page 455

BINNER SERIES

30 POINT

6 A 9 a \$5 00

**MAGNIFICENT
Harbor and River View**

24 POINT

8 A 10 a \$4 50

**RADICAL CHANGES
During Presidential Election**

18 POINT

10 A 16 a \$4 00

**BRITISH NORTH AMERICA
Raising Numerous Valuable Equines
Thoroughly Acclimated**

12 POINT

16 A 20 a \$3 25

**GRAND HOLIDAY
Printers and Editorial
Fabricators**

10 POINT

20 A 26 a \$3 00

**TWILIGHT HUSH
Hence the Shadows Growing
Unsurpassable**

8 POINT

22 A 30 a \$2 75

**WORCESTER CELEBRATION
Attended by Small Army from Ohio
and California, with Bright Bunting**

1 2 3 4 5 6 7 8 9 0

6 POINT

24 A 36 a \$2 50

**FACE OF LATE TYPOGRAPHY
Handsome, Durable and Comprehensive the
Fervor of its Reception Should be Unmixed**

1 2 3 4 5 6 7 8 9 0

Binner Open, registering with the four larger sizes, is shown on page 455

"POST" OLD STYLE ROMAN No 1

72 POINT

3 A 4 a \$19 00

PRINTERS

Are in great

delight over

this Series 8

“POST” OLD STYLE ROMAN No 1

60 POINT

3 A 4 a \$11 50

CHRISTMAS
Roast Turkey
& Cranberry
Sauce with all
side dishes 35

"POST" OLD STYLE ROMAN No 1

54 POINT

3 A 4 a \$10 75

MANOR SOLD
Farm of twenty
acres, including
the most useful
dairy and \$130

"POST" OLD STYLE ROMAN No 1

48 POINT

3 A 4 a \$8 50

CITIZENS FORM REGIMENT

Soldiers returning
from field of battle
receive a splendid
ovation from ♣ 39

"POST" OLD STYLE ROMAN No 1

42 POINT

3 A 4 a \$7 00

CRUEL KING
 History relates
 that Pharaoh's
 reign of Egypt
 was harsh \$12

36 POINT

3 A 5 a \$5 50

GRAND CURLS
 The pride of Peter
 the Great was his
 long flowing lock
 of Whiskers, the
 envy of all ✂ \$15

"POST" OLD STYLE ROMAN No 1

30 POINT

4 A 6 a \$4 25

NEWEST DESIGN
 made from original
 Drawings furnished
 by the originator  
 Ornaments included
 in all fonts  \$9632

24 POINT

6 A 9 a \$3 75

**COMMENDABLE AND
 USEFUL SERIES**

 The various sizes are
 made to line with the aid
 of point justification, and
 will become leading faces
 they being adapted to all
 classes of jobbing 41367

“POST” OLD STYLE ROMAN No 1

18 POINT

8 A 12 a \$3 25

CHEAPNESS EXEMPLIFIED
Our Fifth Annual Sale of Fine
White Lawn Goods begins this
morning. People who watch for
real cheapness in honest goods
will certainly find it here 9802

8 POINT

16 A 24 a \$2 25

IMPRESSIVE OFFERINGS IN REAL ESTATE
CITY AND COUNTRY LOTS CHEAP

The people are learning that prices on all kinds of dependable real estate are lower here than at any other leading houses in our line of trade. There is nothing uncertain about this. It is done in pursuance of a well-considered and perfectly safe plan of business which we are finding very satisfactory and effective. While we are young in this field of enterprise, people have come to look upon us as an extremely precocious and vigorous infant. We shall continue, as heretofore, our weekly price bulletin of real estate bargains 359

14 POINT

12 A 18 a \$3 00

FALL SALE OF DRESS FABRICS
IN BLACK AND COLORS

Judging by the great variety of weaves that are now on exhibition in the Black Dress Goods Department, it would be difficult to name a special leader. From present indications it would appear that Pebble Cheviots will be popular 2478

“POST” OLD STYLE ROMAN No 1

12 POINT

14 A 20 a \$2 75

**DOMESTIC WOOLENS AND WORSTEDS
WONDERFUL AUTUMN SHOWING**

Last week we told you the new woolens and worsteds for the closing sartorial season of the Nineteenth Century were ready. The show is complete, and wonderful in its varied but quiet beauty. Never before were our designers and cutters so fully equal to the fastidious demands of prevailing fashion as at the present time 758

6 POINT

16 A 25 a \$2 00

**EXTRAORDINARY HIGH GRADE PIANO SELLING
VALUABLE INSTRUMENTS SACRIFICED**

We have inaugurated a special piano sale for the month of September to dispose of a large accumulation of very slightly used pianos. The sale is necessitated through extensive alterations made in our crowded warerooms, together with the return of a large number of pianos from summer renters. All the pianos are marked from one-third to one-half below our regular prices. Pianos used by the profession and in concerts during the past season have been correspondingly reduced. All of the instruments offered in this sale are in first-class condition and entirely in keeping with the reputation of this house. Terms of payment are extremely easy 43728

10 POINT

14 A 20 a \$2 50

**STEADY DOWNWARD SLUMP IN COTTON
NOT SUFFICIENT TO RUN MILLS**

The current week begins with less than a three weeks' supply of American cotton in the Liverpool market and about a three days' supply on the sea. Cotton last week was much more active than it had been of late, business nearly equaling the average consumption of spot cotton. Business in yarns was irregularly distributed and was somewhat below the average production, although the improvement on the preceding weeks was very important 6980

"POST" OLD STYLE ROMAN No 2

72 POINT

3 A 4 a \$20 00

DOG RUN
Come and
see Zip the
\$15 beauty

“POST” OLD STYLE ROMAN No 2

60 POINT

3 A 4 a \$13 00

GOLD COIN
The last four
years' output
of gold metal
exceeds \$158

"POST" OLD STYLE ROMAN No 2

54 POINT

3 A 4 a \$11 25

TRIUMPHED
Early History
of America is
filled with the
Record of 248

"POST" OLD STYLE ROMAN No 2

48 POINT

3 A 4 a \$9 50

**HIRAM SLACK
DENTISTRY
Teeth Extracted
without the least
pain; exceptions
made in case \$19**

"POST" OLD STYLE ROMAN No 2

42 POINT

3 A 4 a \$7 50

FIRE SALE
Never before
have carpets
received the
scrutiny \$20

36 POINT

3 A 5 a \$5 75

LIGHT WORK
The sons of rest
are opposed to
this at all times
of the year; in
fact, never £23

"POST" OLD STYLE ROMAN No 2

30 POINT

4 A 6 a \$4 50

GREAT METHOD
☞ **Honest Dealing**
is the great secret
of making friends
in whatever voca-
tion you follow 25

24 POINT

5 A 8 a \$3 50

INCREASE PROFITS
EXPERIENCE

Constant endeavor to
furnish none but the
very best of all classes
of material aids in se-
curing an increase of
patronage ☞ ☞ \$1209

“POST” OLD STYLE ROMAN No 2

18 POINT

7 A 10 a \$3 25

SOUND SWEET MELODIES
Music is the source of our social pleasures; it soothes violent impulses of man, it dignifies church ceremony, and educates the *o o* **264**

8 POINT

14 A 20 a \$2 25

**HANDSOME SCIENTIFIC INSTRUMENT
 STUDY IN ASTRONOMY**

The principle thing in a telescope is the object-glass, which concentrates the rays of light at a focus, and these create an image of the object looked at. The image is in turn magnified by means of a powerful eyepiece resembling a microscope. A good telescope should bear a magnifying power of one hundred diameters for an inch of aperture *o o o*
No telescope is required to see that the surface of the moon is covered in **12345**

14 POINT

10 A 15 a \$3 00

**EDUCATION AND ENJOYMENT
 STUDIES ENLIVENED**

Milton was not only the grandest poet who has lived since Homer, but he was one of the most able schoolmasters of the period, and devised for all his pupils a plan of education in which *o o* **2346**

"POST" OLD STYLE ROMAN No 2

12 POINT

12 A 18 a \$2 75

**AUTUMN EXHIBIT OF DRESS GOODS
FINE SILKS & SATINS**

To-day you are invited to inspect the richest display of Dress Goods, Satins and Silks ever seen in this city ☉ The entire Main Aisle of the Center Store is given up to this great exhibit, the result of an organized, diligent search throughout the markets of the ☉ ☉ 240

6 POINT

15 A 24 a \$2 00

**BLENDED SHADES AND HANDSOME COLORS
HARMONIOUS EFFECTS**

This assemblage of Dress Goods includes every worthy weave that has come from the looms of two continents during the past twelve-month—a collection that must immediately interest every woman in our wide circle of customers ☉ And not one should be disappointed ☉ Many of the fabrics are enriched by scarf lines of threads and colorings, by faint stripes and webbings, and by various other means of ornamentation which reflect the skill of the world's greatest textile artists ☉ ☉ Among the best are textures and designs that are shown exclusively ☉ 81357

10 POINT

12 A 18 a \$2 50

**THE NOVELTIES BAFFLE DESCRIPTION
COME AND SEE THEM**

To adequately describe these Satins and Silks is beyond our power ☉ They show flashes of color and form that know no rule but the artistic impulse of designer and weaver ☉ There are delicate evening shades all aglow with printings of gold in both large and small designs ☉ There are brocaded Panne Velvets with embossings. There are soft weaves of Silk ☉ ☉ 293467

JENSON HEAVYFACE

120 POINT

3 A 4 a \$22 50

FINE**Brake**

60 POINT

4 A 5 a \$12 25

BANGLLED**Designed for
work of 1899**

JENSON HEAVYFACE

96 POINT

3 A 4 a \$19 00

BRICK
Strikers

72 POINT

4 A 5 a \$17 00

SPREAD
Duty Bold
Plants \$2

JENSON HEAVYFACE

48 POINT

4 A 5 a \$7 75

NEW SERIES
Bright Method
Plain 48 Guide

36 POINT

5 A 8 a \$5 50

PRIOR NOTICE
Liberal 56 Patron
Enjoy Clear Strong

30 POINT

6 A 10 a \$5 00

CONVEY MEANING
As necessary for Jenson
Old Style as boldface is
for ordinary romans 73

JENSON HEAVYFACE

24 POINT

10 A 15 a \$4 50

**REWARD FOR BEST LINE
EDUCATED CUSTOMERS**

**Appreciate Progressive Printers
Investing in 53 Modern Letters
Substantial Harvest Gathering**

18 POINT

12 A 20 a \$4 00

**TRADESMENS MODEST PRAISE
IS MERITED IN EVERY RESPECT**

**Every printer should include this series of
Jenson Heavyface in stock for regular use.
Clear-cut characters with a style that will
look well, cast in metal that will wear long**

12 POINT

18 A 30 a \$3 25

**DEMAND FOR JENSON HEAVYFACE IS POSITIVE
PROOF OF ITS POPULARITY WITH THE CRAFT**

**A strikingly handsome and impressive clean cut face made
complete with Figures in 10 well graded sizes, is especially
adapted for use with the Jenson Old Style and is receiving
generous and merited praise from printers of every section.
It has become one of the most popular of our recent products**

BRADLEY EXTENDED

60 POINT

3 A 4a \$10 50

**Spend your
Bank Notes
in Pleasure**

48 POINT

3 A 6a \$8 50

**Nothing would
Satisfy People
so Much as to
know a Friend**

BRADLEY EXTENDED

36 POINT

4 A 10 a \$6 50

**Timely Hints often
Make Fortunes for
Shrewd Negotiator**

30 POINT

5 A 12 a \$6 00

**National Achievement
of Diplomats in recent
years Illuminates our
History with Ambition**

24 POINT

6 A 16 a \$5 50

**The Predominant Ideas of
Modern Acquirement are
both Useful and Expedient
to the Oriental Inhabitants**

BRADLEY EXTENDED

18 POINT

10 A 28 a \$5 00

The rich soil and climate of the State of California are notably adapted to the cultivation of the grape. The delicious richness and flavor of California grapes nothing of the fruit kind equals. They grow to a large size in the vineyards and bring \$12

15 POINT

12 A 36 a \$4 50

The cactus plant grows quickly in this section, and is used for hedging in all places

making an impervious barrier against man and beast. The stalks of some of the plants and shrubs are of the thickness of a man's body and grow to the height of sixteen feet. One of the most serviceable and highly useful plants of California is the soap plant. The 3156

12 POINT

14 A 42 a \$4 00

Sweet is the pleasure
Itself cannot spoil!
Is not true leisure
One with true toil?

Rest is not quitting
The busy career;
Rest is the fitting
Of self to its sphere.

BRADLEY EXTENDED

10 POINT

16 A 48 a \$3 50

Philadelphia, March 29th, 1898.

Gentlemen:

Our salesman, Mr. John Young, will call on your firm on or about the first of next month with a full line of goods for the Fall and Winter Trade. We have added a fine line of inexpensive Parisian Novelties of which we will mail you a few samples. Thanking you heartily for past favors, and hoping for a continuance of the same, we remain,

Yours truly,

Martin Rober & Co.

6 POINT

20 A 60 a \$3 00

I met him in the cars,
Where resignedly he sat;
His hair was full of dust,
And so was his cravat;
He was furthermore embellished
By a ticket in his hat.

The conductor touched his arm,
And awoke him from a nap;
When he gave the feeding flies
An admonitory slap,
And his ticket to the man
In the yellow-lettered cap.

The heads of many men
Were bobbing as in sleep,
And many babies lifted
Their voices up to weep;
While the coal-dust darkly fell
On bonnets in a heap.

All the while the swaying cars
Kept rumbling o'er the rail,
And the frequent whistle sent
Shrieks of anguish to the gale,
And the cinders pattered down
On the grimy floor like hail.

8 POINT

16 A 50 a \$3 25

Office of
Washington Excursion Bureau,
No. 47 First Avenue.

January 21st, 1901.

In obedience to the wishes of our many patrons and the general public, a Chaperone will accompany each one of our Personally Conducted Summer Tours during the forthcoming season. This new innovation will be highly appreciated by parents desiring to send young children.

For detailed account of trips, rate of fare, and other useful information, write to

William Valentine Brown,
General Manager.

BRADLEY SERIES

60 POINT

3 A 5 a \$8 50

Leads the Style
in Black Letters

48 POINT

3 A 8 a \$6 75

Early printers were
loud in their praise

36 POINT

4 A 10 a \$5 00

Gothic went out of fashion
in Germany and France at
the end of the 16th century

Bradley Outline, registering with this series, is shown on page 456

BRADLEY SERIES

24 POINT

5 A 16 a \$3 50

GERMAN printers of 1450 used bold Black Letters so that they could avoid detection in their many undertakings of a hazardous nature

18 POINT

8 A 25 a \$3 25

THE pages of early books were either large or small folios, but sometimes quartos, and were therefore cumbrous and unhandy. • Aldus Manuccio, of Venice, was the first to introduce the

12 POINT

15 A 45 a \$3 00

GAXTON was over sixty years of age when *The Dictes* was printed and was notable for his industrious habit. He possessed good sound

10 POINT

16 A 50 a \$2 75

FAUST and Schœffer printed the Bible, Psalter and other important works. From this rapid summary we may conclude: 1. That the merit of the invention of the art of printing, however rude it may

8 POINT

18 A 52 a \$2 50

Gutenberg continued printing at Strasburg until the year 1444, when, his means being exhausted, he rejoined his uncle at Mentz. Here he renewed his experiments, and, as he needed financial assistance, secured an introduction to John Faust, a money-lender

6 POINT

20 A 60 a \$2 25

The credit of inventing the art which perpetuates the history and achievements of all the arts and sciences has been obstinately contested, several cities having advanced rival claims to the honor of the discovery. This, however, should be no matter of surprise when we consider that the inventor of any new art, unprotected by law, would naturally endeavor to conceal its process for his own use and advantage. • After due

Bradley Outline, registering with this series, is shown on page 456

54 POINT BRADLEY INITIALS 3 A \$4 25
SINGLE LETTER 25 CENTS

42 POINT BRADLEY INITIALS 3 A \$3 00
SINGLE LETTER 20 CENTS

SATANICK SERIES

72 POINT

4 A 5 a \$17 00

Standards

60 POINT

4 A 5 a \$12 25

Demonstrate

54 POINT

4 A 5 a \$10 25

Musicians
Enchantment

48 POINT

4 A 5 a \$7 75

Senatorial
Administrative

Satanick Open, registering with this series, is shown on page 458

SATANICK SERIES

42 POINT

4 A 6 a \$7 25

Enthusiastic
Soldiers Marched

36 POINT

5 A 8 a \$5 50

Cultivators
Mirthful Harvesters

30 POINT

6 A 10 a \$5 00

✿ Legerdemain ✿
Necromancer Rehearsing

24 POINT

6 A 15 a \$4 50

Beautiful Landscape
Realistic Paintings Exhibited

18 POINT

8 A 25 a \$4 00

Rambling Tourist Enchanted
Inspiring Mountain Scenery in Autumn

Satanick Open, registering with this series, is shown on page 458

SATANICK SERIES

12 POINT

10 A 35 a \$3 25

AMERICANS have realized within recent years that there are some provinces by the sea, located as the mariners would say nor'-nor' east of us, which for wholesome climate and varied sights offer a greater wealth of attractions during summer days than is possessed by any other nearby region. Geographers have given to them the name of Maritime Provinces

8 POINT

15 A 50 a \$2 75

THE SHOOTING on Prince Edward Island during the season is exceedingly good, and wild geese, brant, duck, partridge, woodcock and snipe are to be found in abundance, while such streams as the Monce, the Dunk, the Pierrejaques, the Miminigash, the Kildare, Tignish and others, teem with trout and salmon. From any one of the little seaside towns on Prince Edward Island one may have within a half-hour or hour's sail an abundance of mackerel and deep-sea fishing. * * * The island constitutes the smallest of the provinces, but maintains equal dignity with the greatest, having its own provincial government, comprising a governor and parliament, and sending six commoners to

10 POINT

12 A 40 a \$3 00

WESTWARD from Windsor the country takes on a different character. Barren rocky slopes have given way to fertile fields. The hills have drawn apart and the Gasperau Valley spreads out its verdure-covered meadows and luxuriously-foliaged orchards on every hand. Over to the right sparkles the Bay of Minas, and outlined on the horizon is grand old Blomidon, that majestic bastion, keeping faithful sentinel, as in the days of Evangeline, over the turbulent waters, which rise and fall with mighty force at its rocky base, guarding the peaceful valley

6 POINT

15 A 50 a \$2 50

FROM HALIFAX fishing trips may be taken either by the several coach lines along the coast, or by private conveyances, which are to be obtained at reasonable cost. There is good sport along the western shore all the way to Chester and Gold River. Indian River, twenty-one miles from Halifax, and Ingram River, distant twenty-five miles, are also good points, as is Grand Lake. At St. Margaret's Bay may be found an old-fashioned inn and guides. Indian Lake, about eight miles from Halifax, on the Prospect Road, Peters Lake, Spruce Hill Lake and Nine Mile River are good points for the Spring and Summer sport. * * * It is impossible, in an article of this length, to give a list of all the favorite places for sport, but this information can readily be secured in Halifax or any of the larger or smaller towns. No reference to fishing in the Provinces would, however, be complete without mention of that most famous of all salmon waters, the Margaret River in Cape Breton

ARLINGTON SERIES

48 POINT

4 A 5 a \$7 75

ARLINGTON SERIES—Two New Sizes

72 POINT

3 A 4 a \$11 15

FINANCE
Reporters

60 POINT

4 A 5 a \$8 90

INSPECTOR
Exclamation

EVER SINCE THE FIRST ONE
was built ~ Pastoral 8

SATANICK SERIES

12 POINT

10 A 35 a \$3 25

... twenty-one miles from Halifax, and Ingram River, distant twenty-five miles, are also good points, as is Grand Lake. At St. Margaret's Bay may be found an old-fashioned inn and guides. Indian Lake, about eight miles from Halifax, on the Prospect Road, Peters Lake, Spruce Hill Lake and Nine Mile River are good points for the Spring and Summer sport. * * * It is impossible, in an article of this length, to give a list of all the favorite places for sport, but this information can readily be secured in Halifax or any of the larger or smaller towns. No reference to fishing in the Provinces would, however, be complete without mention of that most famous of all salmon waters, the Margaret River in Cape Breton

ARLINGTON SERIES

48 POINT

4 A 5 a \$7 75

SONG OF HOMIE
Composed by one
who Never spent
a Minute there 3

36 POINT

5 A 8 a \$5 50

THE RUSTIC BRIDGE
Has been the Subject
for Poets and Artists
ever since the first one
was built ~ Pastoral 8

ARLINGTON SERIES

30 POINT

6 A 9 a \$5 00

ADVANTAGES RECORDED
EVEN if our Prices were
 just as high as those of
 the average Store, it would
 pay you to come miles to
 Purchase Here ~ ~ \$32.68

24 POINT

8 A 10 a \$4 00

SHOES TO PLEASE EVERYBODY
 ~ ~ **LATEST FOOTWEAR** ~ ~

THIS Department has earned its
 great popularity by Studying
 and Filling the wants of Patrons,
 who find our Shoes to be as good
 as those much more Expensive

~ 1234567890 ~

ARLINGTON SERIES

18 POINT

10 A 16 a \$3 25

MIDWINTER SALES OF FINE CLOTHING**~ ~ GREATEST VALUES ~ ~**

FROM the same manufacturer who sent us the Overcoats which made such a stir among Young Men during the past week, we have bought a lot of Clothes for Men, which go on Sale to-day ~ ~ \$30.24

10 POINT

20 A 26 a \$2 75

GRAND EXHIBIT OF IMPORTED AND DOMESTIC MILLINERY**~ ~ OPEN EVENINGS UNTIL TEN ~ ~**

TO-DAY'S showing of Trimmed Hats is so unique, so great, so different from any other ever seen, that you should not miss it. This is the fashion center for admirers of all that is stylish and elegant in the Millinery world. Our own special and exclusive designs are side by side with the finest copies of the best foreign models. In this beautiful display, newly trimmed Hats are numbered by the thousands, and have no equal for richness

1 2 3 4 5 6 7 8 9 0

12 POINT

16 A 20 a \$3 00

COME AND INSPECT OUR DISPLAY OF ORIENTAL SILKS**~ ~ NOTEWORTHY BARGAINS ~ ~**

OUR Silk Salon blooms with a magnificent collection of filmy weaves in all the characteristic New Designs, and we have dressed the Salon in gala attire in their honor; the Japanese Silks are shown in an Oriental booth by themselves. To crown all, the Prices are the same as during the Summer, and means that they are Twenty Per Cent. less than present prices \$238

JENSON OLD STYLE

72 POINT

4 A 5 a \$17 00

ROMANS
 Grand pieces
 third year 25

60 POINT

4 A 5 a \$12 25

FOUNDERS
 Original model
 artistic faces 13

See Index for Jenson Initials and Jenson Embellishments suitable for use with above Series

JENSON OLD STYLE

54 POINT

4 A 5 a \$10 25



ORIGINAL

English founders
cast Diamond as
far back as 1700

48 POINT

4 A 5 a \$7 75

DESIGNING

The date at which
we quit the survey
is not glorious  

See Index for Jenson Initials and Jenson Embellishments suitable for use with above Series

JENSON OLD STYLE

42 POINT

4 A 6 a \$7 25

DARING RIDERS
Surge over the plains
beyond 36 castles. 

36 POINT

5 A 8 a \$5 50

SINGLE 25 JUSTICE
Full of healthy sense and
inspiration for all nations

30 POINT

6 A 10 a \$5 00

DEMAND FOR UNIQUE
Effects which surprise the eye
and amaze the brain cost less
in the end than ordinary 780

See Index for Jenson Initials and Jenson Embellishments suitable for use with above Series

JENSON OLD STYLE

24 POINT

10 A 15 a \$4 50

PRICES BASED ON FIGURES

The check to uncertain estimating is in keeping a record of every item of expense that enters into the work and comparing it with the estimate when the job is completed. It is the only practical method of arriving at tangible facts on which to base the cost of your own productions 47. 

18 POINT

12 A 20 a \$4 00

ENLIGHTEN HONEST CUSTOMERS

In one particular it is always wise to enlighten every patron in order to reach a basis of mutual understanding when contracts are made. Most people are more or less ignorant of the customs and terms of the trade. This ignorance leads to much disputing and rankling dissatisfaction on the part of customers. Well-meaning and honest though they are, it is difficult for them to understand why the bill should be \$329. 

See Index for Jenson Initials and Jenson Embellishments suitable for use with above Series

JENSON OLD STYLE

14 POINT

15 A 25 a \$3 50

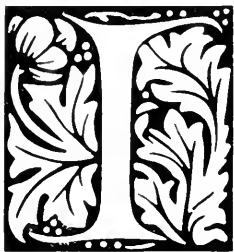
ON THE PROGRESS IN MACHINERY AND
THE MAKING OF NEW TYPE FACES. ❁❁❁

IN 1835 I saw for the first time the printing house of Harper & Brothers. With childish awe I watched the flutter of the friskets of a dozen hand presses, and the slow but steady piling-up of printed sheets on the bank. Could any machines be finer or better? So I thought, and so Harper & Brothers thought; but in a few years the hand presses were supplanted by the Adams. This change was but the beginning of a series of changes that I can sketch in outline only. The two-roller Adams of wood frame was followed by the four-roller machine of iron frame and \$4295

12 POINT

18 A 30 a \$3 25

MODERN VERSION OF THE WORLD OLD STORY
OF MAKING BRICKS WITHOUT STRAW ❁❁❁❁❁

WHEN we discover here and there a printer wasting his energies and abilities in the vain endeavor to execute printing to the satisfaction of his clients with type lacking in originality, in art, and devoid of the life that can only be imparted by a genius in designing, we are reminded of the cruel task allotted to the Hebrews by the old Egyptians. There is neither profit nor pleasure in trying to impart an artistic effect with in-artistic type. It is a question whether the durability of such type is not an added injury to the unfortunate printer who uses it. Pound for pound the type of the American Type Founders Co. costs no more than type unenlivened by artistic merit; but in its true value it surpasses all other type as the masterpieces £376

See Index for Jenson Initials and Jenson Embellishments suitable for use with above Series

JENSON OLD STYLE

10 POINT

25 A 30 a \$3 00

HE HAS DEMANDS FOR FACES BOLD AND BLACK, LIGHT AND SKINNY, BROAD, CONDENSED, LARGE 



MALL, with long ceriphs, with short ceriphs, with high ascenders, with short descenders, and other mannerisms too tedious to describe. We are asked to get these in fonts of thousands of pounds, but to buy half of them, or quarter of them, is to invite bankruptcy. There are publishers who ask that thousands of pages be kept standing for months. There are men before me who have sent, and are sending, proofs to Europe, and even to the Pacific Islands, and Asia. A prominent printer of Paris told me that the weight of the book types in his house largely exceeded two million pounds. The tied-up pages piled up like bricks on every floor of the house was proof of the statement. Fifty years ago a book and job printer could keep sixty compositors at work on a plant of types and appurtenances that cost less than \$10,000.

6 POINT

35 A 50 a \$2 50

A GOOD FEATURE IN PREVAILING FASHIONS IS THE GENERAL DISLIKE FOR ALL ORNAMENTAL AND FRAIL TYPES.



HEN Whittinghouse of London revived the trade for old style letter, in 1844, the old order changed. Not liked at all in the beginning, old style slowly grew in favor, especially with those who wished to give distinction to their work. Before 1860 it was required of every prosperous book and job printer that he should have a full series of old style faces, complete from Pearl to Canon. This compelled a doubling of the expense of equipping the composing room; but if the demand for novelty had stopped here, this added expense might not need any notice. But it did not stop with the modernized old style. Think of the varieties now offered to us by the type founders—Caslon, Franklin, Barth, Binny, Ronaldson, Cadmus or Elzevir, French, Jenson, etc. Nor is this all: other faces with peculiar mannerisms are made abroad, and there are publishers who will have them. Standard or modern-cut Roman is provided by type founders in greater variety. The book printer who has two faces only in series soon finds them insufficient. He has demands for others.

8 POINT

25 A 35 a \$2 75

THE MANUFACTURERS OF OUR MACHINES ASSURED US AGAIN AND AGAIN THAT THEIR LAST MACHINES WERE PERFECTION. 



It was not possible to make anything better; they would meet every demand for strength, speed, accuracy, and ease of handling. So they did for a time; but in a few years on came the improvements, once declared impossible, and in the form of larger and more efficient machines. The presses that were the best of their kind in 1865 proved too small and too slow in 1875. To continue to use them would be to do work at cost or at loss. When one has room enough, the old machines may be set aside and put to an inferior class of presswork. But when rents are high and space is contracted the old machines must be sold. What do we get for old presses? It often happens that after only seven or ten years of service, the press that cost \$3000 or \$5000 will be sold for from \$300 to \$600. It is not worn out, it may be in good condition, and should be efficient for twenty years more, but it must be sold because it is not up to present needs. It will not pay to keep it when your rival is using new machines.

See Index for Jenson Initials and Jenson Embellishments suitable for use with above Series

SCHÖEFFER OLD STYLE

PATENTED

72 POINT

3 A 4 a \$8 50

DESERVING
Student tried
for Diplomas

60 POINT

3 A 5 a \$7 00

REMARKABLE
Time was made
on the Voyages

SCHÖEFFER OLD STYLE

PATENTED

48 POINT

4 A 7 a \$6 00

BRIGHT PERSONS
Blessed with Sound
Health and Millions

36 POINT

6 A 9 a \$5 00

CHARITABLE REMEDY
We should always assist
those who are deserving

30 POINT

8 A 12 a \$4 50

INTREPID AND PATRIOTIC
They stood on the deck like
heroes, so firmly intent were
they on the seizure of the fort

SCHÖEFFER OLD STYLE

PATENTED

24 POINT

12 A 18 a \$4 00

ADVANTAGES OF KNOWLEDGE

FORTUNE may be left to us by our parents, but the resources of education must be developed by ourselves, or we must lack it forever

48 POINT SCHÖEFFER OLD STYLE INITIALS 3 A \$4 00

10 POINT

25 A 50 a \$2 25

FOR HIS GREAT QUALIFICATION PETER SCHÖEFFER WAS MADE MANAGER OF THE OFFICE IN MENTZ

PETER SCHÖEFFER before the age of twenty years was considered a perfect copyist of old manuscripts, with a slight knowledge of printing taught him by Gutenberg. He attracted the attention of Fust, who found in him one who could cleverly manage a Printing Office, and by adding to his great knowledge the acquirement of ingenuity, he made many acceptable changes in the pages of the Bible and Psalter. Between 1462 and 1464 turbulent times occurred in Mentz and business was at a standstill.

24 POINT SCHÖEFFER OLD STYLE INITIALS 6 A \$2 50

18 POINT

15 A 25 a \$3 50

DIFFICULTY IN CHOOSING COMPANIONS

THE task is a dilemma, but we all should endeavor to make a good selection and not come to hasty conclusions as to the relative value of our friends, for in many instances time may develop a different phase of character, and

36 POINT SCHÖEFFER OLD STYLE INITIALS 4 A \$3 50

SCHÖEFFER OLD STYLE

PATENTED

15 POINT

18 A 30 a \$3 00

AN IDEA OF DISCOVERING A NEW HEMISPHERE

IT was Columbus, the intrepid Italian, who conceived the idea about the world being round instead of flat, and who sailed off into an unknown sea in the expectation to discover a hemisphere of two continents. Encouraged by the Spanish Crown in his undertaking, he set sail on August 3, 1492, sailing in a westerly direction.

36 POINT SCHÖEFFER OLD STYLE INITIALS 4 A \$3 50

8 POINT

25 A 50 a \$2 00

A CURTAILED DESCRIPTION OF SOME THINGS THAT WERE NOTICED WHILE EXPLORING THE GREAT MAMMOTH CAVE

THIS is a very interesting journey indeed. On arriving at the Cave one is astonished to view an immense rock over the entrance supported only by a very small stone, which if displaced would close the entrance forever and entirely entomb those inside. Leaving this fear aside, we find, on entering, several large rooms of wonderful size, also a running stream, a star-chamber, lighted by numberless small stars, and many strange carvings surprising to behold and to contemplate. Some of the chambers are very cold and others warm. This is said to be from changes of wind, in the same manner as those above the ground. The wonders of the Cave are explained by an experienced guide, without whose aid one would be lost forever in the vast space of this natural wonder.

15 POINT SCHÖEFFER OLD STYLE INITIALS 6 A \$1 50

12 POINT

20 A 40 a \$2 50

FEW THOUGHTFUL POINTS ON THE STUDY OF ASTRONOMY

IT will be very interesting, to many of us, to note the fact that during the month of August there is to be seen Jupiter and Venus in conjunction. It takes place low down in the western part of the horizon, and will be worth all the trouble we can take to witness such beautiful display; also the conjunction of Jupiter and the Moon, and Venus and the Moon. It is an infrequent occurrence to see these three bodies so close together, and the students should therefore avail themselves of this rare opportunity of viewing them.

24 POINT SCHÖEFFER OLD STYLE INITIALS 6 A \$2 50

HOWLAND SERIES

96 POINT

4 A 5 a \$15 00

Hard and

120 POINT

3 A 4 a \$19 00

BIG

12 POINT

20 A 30 a \$3 00

OUR BIG SIZES CAST IN
HARD DURABLE METAL

All new sizes to complete
any of our popular series,
up to and including 120
Point, are Cast in Metal;
they are NOT wood type

72 POINT

4 A 5 a \$12 00

FOUR HUNG Strong Lines

Howland Open, registering with this series, is shown on pages 466 and 467

HOWLAND SERIES

96 POINT

4 A 5 a \$15 00

MURDER

10 POINT

24 A 36 a \$2 75

PRINTERS CAN APPRECIATE
THE THREE NEW SIZES WE

Show on these pages. They are
the 72, 96 and 120 Point sizes,
and they are every way just as
useful as the smaller sizes. In
fact they could not well be any
more useful, as printers know

120 POINT

3 A 4 a \$19 00

Dog

72 POINT

4 A 5 a \$12 00

QUICK TIME

Scare Heads

Howland Open, registering with this series, is shown on pages 466 and 467

HOWLAND SERIES

42 POINT

6 A 10 a \$6 00

FIGURING FOR PROFITS

Reliable Printing Concern

60 POINT

4 A 5 a \$9 00

GRAND Masher

8 POINT

28 A 40 a \$2 50

NOW FOURTEEN NICELY GRADED
SIZES IN THIS HANDSOME SERIES

Useful alike in Newspaper and Job work, and gives the best satisfaction wherever used. Special attention is called to the capital O, which being made in two degrees of fatness, is a great help in making a line fill out to the required length. This feature is oftentimes the means of saving a lot of valuable time for the printers

30 POINT

8 A 12 a \$5 00

DISCHARGE ONE MUSICIAN

Charming Melodious Strains

24 POINT

10 A 16 a \$4 00

DESIGNING HANDSOME BROCHURE

Quickly Readable Impression Pages

Howland Open, registering with this series, is shown on pages 466 and 467

HOWLAND SERIES

48 POINT

5 A 8 a \$7 00

UNIQUE AND BRIGHT Reclaimed Character

6 POINT

30 A 50 a \$2 25

CLEAN AND LEGIBLE FIGURES PUT UP WITH EACH OF THE FOURTEEN SIZES, AND A PLENTY OF THEM \$1,234,567,890

Printers who already have this series to and including the 60 Point cannot make a better move than to order the 72, 96 and 120 Point sizes shown on preceding pages. Such a movement is certain to be a profitable one when the popularity of the Howland Letters is considered. The complete series, with double fonts of the small sizes, constitutes an item of your composing room equipment that cannot fail in paying handsomely for the outlay

54 POINT

4 A 6 a \$8 00

QUINCES Jelly \$62

18 POINT

12 A 20 a \$3 25

EXTRAORDINARY BARGAINS IN COMFORTABLES AND DOUBLE BLANKETS FOR CAMPING PARTIES

HOLDING perhaps the largest stock of vacation supplies in this part of the country, we have concluded to make an effort to reduce many of our lines before the season closes. To this end we have marked all goods to absurd prices \$46.59

Howland Open, registering with this series, is shown on pages 466 and 467

COLUMBUS No 2

PATENTED

60 POINT

3 A 4 a \$12 35

NO Card

36 POINT WITH 60 POINT INITIALS

RAISE Vines

48 POINT

3 A 5 a \$9 35

Same CAR

24 POINT WITH 48 POINT INITIALS

Chivalrous LADIES

36 POINT

5 A 8 a \$8 00

GAME Record

Columbus Outline, registering with this series, is shown on pages 460 and 461

COLUMBUS No 2

PATENTED

Columbus Initials

24 POINT

10 A 15 a \$7 05

MORE Homes

18 POINT

15 A 20 a \$6 10

**ANIMATED
Fervent Comedian**

15 POINT

18 A 25 a \$5 00

**WINTER GAMES
Stormy Weather Endured**

12 POINT

25 A 35 a \$4 25

**HANDSOME STEAMER
Expedition Traveling Homeward**

10 POINT

26 A 40 a \$3 75

**ELECTRIC LIGHTING
Resplendent Spectacular Extravaganza**

8 POINT

30 A 45 a \$3 50

**SPARKLING OPERATIC COMEDY
Burlesque Company Received Great Applause**

6 POINT

35 A 50 a \$3 25

**FALLTIME CLOTHING SACRIFICED
Bargain Sale Advertised for Every Tuesday in March
1234567890**

18 POINT WITH 36 POINT INITIALS

Quaint SCENE

Columbus Outline, registering with this series, is shown on pages 460 and 461

36 POINT \$2 00
48 POINT 3 00
60 POINT 4 00

Fonts contain the above
capitals only

**B
C
E
F
K
L
O
Q
R
S
T
V
W**

QUENTELL SERIES

72 POINT

4 A 5 a \$17 00

TIME Runs

60 POINT

4 A 5 a \$12 25

Count GIRLS

54 POINT

4 A 5 a \$10 25

NIGHT Return

48 POINT

4 A 5 a \$7 75

Order GENERAL

42 POINT

4 A 6 a \$7 25

**EXCURSIONS
Divorce Register**

QUENTELL SERIES

36 POINT

5 A 8 a \$5 50

PERFORMANCES
Remarkable Country

30 POINT

6 A 9 a \$5 00

CORRESPONDENCE
Distinguished Questions

24 POINT

8 A 10 a \$4 00

ENTERPRISING MERCHANT
Sending Phonograph Message

18 POINT

10 A 16 a \$3 25

UNREALIZATION
Beautiful Floriated

14 POINT

12 A 18 a \$3 25

BASEBALL GAMES
Enchanted Amusement

12 POINT

16 A 20 a \$3 00

POCKET ESTIMATE
Provocation and Sensation

10 POINT

20 A 26 a \$2 75

PHOTOGRAPHERS RESOLUTION
Beautiful, Glorious and Charming

8 POINT

22 A 30 a \$2 50

THROUGH COUNTLESS DANGERS
Charitable Society Distributing Clothing
1 2 3 4 5 6 7 8 9 0

6 POINT

24 A 36 a \$2 25

PATENT CYLINDER PRINTING MACHINE
Magnificent Assortment Woodwork Exhibited
1 2 3 4 5 6 7 8 9 0

QUENTELL FRACTIONS

1/4 1/2 3/4 1/8 3/8 5/8 7/8 1/3 2/3 1/4 1/2 3/4 1/8 3/8 5/8 7/8 1/3 2/3

PRICES: 6 POINT TO 24 POINT, INCLUSIVE, 50 CTS. PER FONT; 30 POINT AND 36 POINT, 75 CTS. PER FONT.

Made for all sizes on this page

TAYLOR GOTHIC

48 POINT

4 A 5 a \$7 75

**PLEASING
Newest Master**

36 POINT

5 A 8 a \$5 50

**EXCURSIONS
Returning Delegates
Butter Cakes**

24 POINT

10 A 15 a \$4 50

**DARKEST
African Mines
Studying**

18 POINT

12 A 20 a \$4 00

**INDUSTRIAL
Workers Gathered
Destructions**

12 POINT

16 A 25 a \$3 25

**YOUNG HEROES
Purchase Made Christmas
1 2 3 4 5 6 7**

10 POINT

20 A 30 a \$3 00

**PRINTING MATERIAL
Handsome Durable and Extensive
1 2 3 4 5 6 7 8 9 0**

CASLON CONDENSED

60 POINT

3 A 5 a \$9 00

DRUGS Known

48 POINT

3 A 5 a \$5 50

Northern HUNTERS

36 POINT

4 A 8 a \$5 00

**UPHOLSTERER
Engraved 56 Furniture**

30 POINT

5 A 10 a \$4 50

**NOTICES PRINTED
Removed Handsome Gardens**

24 POINT

6 A 12 a \$3 50

**BORDERING
Flower 43 Houses**

18 POINT

8 A 16 a \$3 00

**DEMONSTRATIONS
Remarkable Consignment
Performances**

McCULLAGH SERIES

72 POINT

3 A 5 a \$9 50

HOUR CLOCKS

60 POINT

3 A 5 a \$8 50

Antique BARGE

48 POINT

4 A 7 a \$6 50

**CHIVALROUS
Mountain Climbers**

42 POINT

5 A 8 a \$6 00

**UNGOVERNABLE
Conditions Described**

McCULLAGH SERIES

36 POINT

6 A 9 a \$5 50

ROAMING AMAZONS
Nomadic Habits Unenvied

30 POINT

7 A 10 a \$4 25

INGENIOUS MECHANICS
Handsome Lakeview Residence

24 POINT

8 A 12 a \$4 00

DOCTORS EDITING JOURNALS
Renowned Medical Manuals Published

18 POINT

10 A 14 a \$3 25

DEMANDING EXORBITANT INTEREST
Conventional Inducement of Investment Company

12 POINT

16 A 20 a \$3 00

BENEVOLENT GOVERNMENT
Wounded Combatants Pensioned
1 2 3 4 5 6 7 8 9 0

10 POINT

20 A 26 a \$2 75

ENTERTAINING SOCIETY MAIDENS
Admiring Juvenile Comedians Simplicity
1 2 3 4 5 6 7 8 9 0

IROQUOIS SERIES

60 POINT

3 A 4 a \$12 00

OPEN
Scandal

48 POINT

3 A 4 a \$8 00

PUBLIC
Cash Lost

36 POINT

3 A 6 a \$6 50

— HOUND —
Rough Antics

30 POINT

4 A 8 a \$5 50

ENTOMBED
Staunch Heroes

IROQUOIS SERIES

24 POINT

5 A 10 a \$4 50

GUARDIANS
Defending Entrance
Swell Regiments

18 POINT

6 A 12 a \$3 30

SMART LEADER
Promotes Valiant Soldier
Daring Shots

12 POINT

10 A 18 a \$2 40

PATRIOTIC DEMONSTRATION
Eminent Speakers Praise Volunteers
Greatest Enthusiasm

10 POINT

14 A 20 a \$2 35

TRIUMPHANT TROOPS ARRIVE
Beautiful Maidens Welcome the Conquerors
Extensive Preparations

8 POINT

15 A 30 a \$2 10

PRELIMINARY PEACE NEGOTIATIONS OPENED
Interference of Foreign Diplomats Emphatically Rejected
Territorial Expansion and Indemnity

6 POINT

20 A 40 a \$2 40

REBUKE ADMINISTERED TO COUNTRY JOURNALS
Indiscreet Reporters were Summarily Removed from Headquarters
Transports Arrive with Convalescents

IROQUOIS CONDENSED

60 POINT

3 A 5 a \$9 00

BORNEO
East Indies

48 POINT

4 A 6 a \$6 50

CLOISTER
Lake Superior

36 POINT

5 A 8 a \$4 90

HISTORICAL
Southern Metropolis

30 POINT

6 A 9 a \$4 25

IMPROVEMENTS
Mechanical Department

IROQUOIS CONDENSED

24 POINT

8 A 12 a \$3 75

AMERICAN CONSULS
Diplomatic Services Rendered
Mercantile Gains

18 POINT

10 A 16 a \$3 00

OCEANIC MINING COMPANY
Natural Resources Become Exhausted
Alchemistical Schemes

12 POINT

12 A 20 a \$2 75

→ DISASTROUS RAILROAD COLLISIONS ←
Returning Excursionists Delayed Through Wrecked Trains
Several Miraculous Escapes

10 POINT

15 A 25 a \$2 50

POLICE OFFICERS CAPTURE CHINESE HIGHBINDERS
Celestial Secret Societies Banded Together for Murder and Arson
Authorities Make Startling Discoveries

8 POINT

20 A 30 a \$2 25

MOUNTAINOUS SUMMER RESORT FOR DYSPEPTIC BAGHELORS
Unsurpassed Facilities for Recreation without Disturbance by Chattering Society Girls
Prominent Specialists Attend Nervous Derangements

6 POINT

25 A 35 a \$2 00

→ SAUNTERINGS AND REMARKABLE ADVENTURES IN PICTURESQUE PALESTINE ←
Conclusive Evidence of Turkish Mismanagement Found Everywhere Among Ruins of Ancient Prosperity
Latest Researches Disclose Buildings of Architectural Beauty and Splendor

CAXTON BOLD

72 POINT

3 A 5 a \$15 00

ROMAN
Chariots

60 POINT

3 A 6 a \$11 75

MURDER
Resources

48 POINT

4 A 8 a \$9 50

SWEARING
Phonographs

CAXTON BOLD

36 POINT

5 A 10 a \$8 50

CORN BROKER
Member Chicago

30 POINT

6 A 12 a \$5 60

HOUSEHOLD GEMS
Domestic Silverware

24 POINT

8 A 16 a \$4 90

EUROPEAN PICTURES
Electric Design Beautiful

18 POINT

10 A 20 a \$3 85

NEBRASKA EXCURSIONISTS
Building Operations Completed

12 POINT

18 A 36 a \$3 40

BASEBALL UMPIRE
Theatrical Celebrities
Forbids Encroachment

8 POINT

24 A 48 a \$3 20

NATIONAL CONVENTIONS
Timely Arbitration Necessary
Chrysanthemum Exhibitions

1234567890

10 POINT

20 A 40 a \$3 00

COUNTLESS BREAKERS
Provocation and Sensation
Through Countless Paths

6 POINT

24 A 48 a \$2 60

CYLINDER PRINTING PRESSES
Splendid Assortment Woodenware
International Tariff Complications
Made the Fastest Time on Record

1234567890

EASTMAN SERIES

72 POINT

3 A 5 a \$10 65

MINES
Enhanced

60 POINT

4 A 5 a \$9 90

DREAMS
Imagination

48 POINT

4 A 6 a \$8 95

FICTION
Ghost Stories

EASTMAN SERIES

36 POINT

5 A 8 a \$5 50

ATHLETIC Olympian Games

30 POINT

6 A 9 a \$5 00

GYMNASTICS Interesting Tournament

24 POINT

8 A 10 a \$4 00

CHAMPION PITCHER Rowing and Cricket Matches

18 POINT

10 A 16 a \$3 25

PREVIOUS Records Broken

12 POINT

16 A 20 a \$3 00

INTERNATIONAL Amateur Bicycle Race

10 POINT

20 A 26 a \$2 75

SHARP FIELDING Defeated the Visiting Team

9 POINT

20 A 40 a \$2 55

SUBURBAN RIDERS Demand Tollgates Abolished

8 POINT

22 A 30 a \$2 50

AMERICAN SPORTSMEN Receive an Ovation in England 1 2 3 4 5 6 7 8 9 0

6 POINT

24 A 48 a \$2 30

GOLF AND HOCKEY GROUNDS Opening Games on the Splendid Links Fine Contests Expected 1 2 3 4 5 6 7 8 9 0

RONALDSON CLARENDON

48 POINT

5 A 8 a \$8 35

Rubber SHOES

36 POINT

6 A 10 a \$7 00

HONEST Merchant

30 POINT

8 A 16 a \$6 05

STARVATION**Stoppage for Luncheon**

24 POINT

10 A 20 a \$5 00

**SUGAR
Maple Region**

18 POINT

14 A 28 a \$4 65

**WEDDINGS
Joyous Occasions**

12 POINT

22 A 45 a \$3 95

**REFORMATION
Honest Officials Accept
Public Trusts**

10 POINT

25 A 50 a \$3 55

**EXAMINATIONS
Application Blanks Mailed
Gratuitously**

8 POINT

30 A 60 a \$3 45

**POLITICAL PROBLEM
Discovering Methods to Secure
Rapid Postal Service
1 2 3 4 5 6 7 8 9 0**

6 POINT

36 A 70 a \$3 35

**EXPOSTULATING CITIZENS
Freeholders and Taxpayers Combined
Grand Mass Meeting
1 2 3 4 5 6 7 8 9 0**

LIPPINCOTT SERIES

PATENTED

60 POINT

4 A 6 a \$9 00

BRISK Dames

48 POINT

4 A 7 a \$6 50

Rare MUSIC Box

36 POINT

6 A 8 a \$5 00

Aspirants EXAMINED

30 POINT

7 A 10 a \$4 25

Quaint HAMBURG Stones

24 POINT

10 A 15 a \$3 75

**URCHINS
Grand Display**

18 POINT

12 A 18 a \$3 25

**ANTIQUATED
Miniature Camera**

12 POINT

22 A 35 a \$3 00

**PARISIAN HEADREST
Beautiful Result Obtained**

10 POINT

28 A 40 a \$2 75

**EVENING PROMENADES
Invigorating and Rejuvenating**

8 POINT

30 A 50 a \$2 50

**AMATEUR KODAK SOCIETY
Picturesque Moonbeams Reproduced**

6 POINT

35 A 52 a \$2 25

**UNIVERSAL ART EXHIBITION
Highly Complimentary Marine Photography**

1 2 3 4 5 6 7 8 9 0

1 2 3 4 5 6 7 8 9 0

RIMPLED SERIES

48 POINT

4A 6a \$7 00

ARISTOCRAT
Ask your cousin
for twenty cents

36 POINT

5A 8a \$5 00

DRIVERS NOTICE
Horses must be kept
off promenades 720

30 POINT

6A 9a \$4 25

CHEERFUL REMARK
Universal peace arriveth
after everybody is gone
to lands beyond the Sea

RIMPLED SERIES

24 POINT

8 A 12 a \$3 50

PROWLING SONGSTERS
 Parading in Automobiles on
 the highway at midnight 124

18 POINT

12 A 18 a \$3 25

ELECTRIC MOTOR EXPLOSIONS
 Disastrous effects caused by the concus-
 sion. The men gave vent to their rage
 in such a way that the air became blue

12 POINT

20 A 30 a \$3 00

BARGAIN COUNTERS FULL OF NOVELTIES
 To-morrow will be a money-saving day at this store.
 Astonishing offers in reliable merchandise of every
 description at decidedly interesting prices. We hold
 the key to the situation, and will help you to save
 money. Select what you want, and pay as you wish

10 POINT

22 A 35 a \$2 75

EXTRAVAGANT PRESENT
 Ring with twelve diamonds
 and a turquoise presented
 to a lovely Senorita of ex-
 ceptional beauty who can
 dance like a dream and sing
 and warble like a sparrow
 1234567890

8 POINT

25 A 40 a \$2 50

BETTER LATE THAN NEVER
 We are offering the last oppor-
 tunity for all surplus stock of
 Golf Clubs at half price and less.
 The next few days at our Bazaar
 will be lively. Our goods must
 be got rid of. A long-time credit
 will take the place of cash down
 1234567890

FLORENTINE HEAVYFACE

48 POINT

4 A 5 a \$7 75

SOUNDING Army 9 Packs

36 POINT

5 A 8 a \$5 50

PORTSMOUTH Cruiser 83 Station

24 POINT

8 A 10 a \$4 50

REGULAR SOLDIERS Gentlemanly 25 Characters

18 POINT

10 A 16 a \$4 00

AMERICAN Type 8 Founder

10 POINT

20 A 26 a \$3 00

HUMBUG OINTMENT Efficacious 9 Medicaments

6 POINT

24 A 36 a \$2 50

ENDURE EASTERN HARDSHIPS Mountain Climbers \$34 were Exhausted

12 POINT

16 A 20 a \$3 25

TEXAS RANGERS Marching to Quincy 8

8 POINT

22 A 30 a \$2 75

DELIGHTFUL PAGEANTS Viewed from a Hundred Stands 24

5 POINT ON 6 POINT

24 A 36 a \$2 50

BASKING IN WINTERS CHILLY WEATHER Enjoying the Lavishly-Stocked Larders £254179

DE VINNE EXTENDED

72 POINT

3 A 4a \$21 00

GUM
Bands

60 POINT

3 A 4a \$16 00

FINE
Grinder

54 POINT

3 A 4a \$13 00

STAR
Beamed

DE VINNE EXTENDED

48 POINT

3 A 4 a \$11 50

HOME
Fashions

42 POINT

4 A 5 a \$10 00

FARMS
Fine Cattle

36 POINT

4 A 6 a \$8 00

SPRING
Sugar Barrel

30 POINT

5 A 8 a \$7 00

INDUSTRY
Missouri Firms

DE VINNE EXTENDED

24 POINT

6 A 10 a \$6 00

EXPOSITION
Home Manufacture

18 POINT

9 A 12 a \$4 50

UNIFORM PRINT
Looks Plain and Artistic

14 POINT

10 A 14 a \$3 75

BEAUTIFUL SCENE
Views From Excursion Boats

12 POINT

14 A 18 a \$3 50

NINETEENTH CENTURY
Base Ball and Lawn Tennis Player

10 POINT

18 A 24 a \$3 00

EUROPEAN BICYCLE EXHIBITION
American Products Receive Highest Awards
Enterprising Competitors

8 POINT

22 A 30 a \$2 75

MODEST YOUTHS
Introduced to Director
Gratifying Result
12345678

6 POINT

24 A 36 a \$2 50

JUVENILE ORCHESTRA
Renders Popular Selections
Thursday Evening
1234567890

DE VINNE SERIES

72 POINT

4 A 5 a \$17 00

MODISH
Costume

60 POINT

4 A 5 a \$12 25

MERIDEN
Romances

54 POINT

4 A 5 a \$10 25

DESIGNER
Bond Notes

DE VINNE SERIES

48 POINT

4 A 5 a \$7 75

**EXPORTING
Cheap Grade
of Neckwear**

42 POINT

4 A 6 a \$7 25

**BAKED SHAD
Served Daily to
Regular Guests**

36 POINT

5 A 8 a \$5 50

**HEROIC ACTION
Under Heavy Fire
by a Young Cadet**

DE VINNE SERIES

30 POINT

6 A 9 a \$5 00

RIGHTS OF LIBERTY
When in the course of
events it becomes 503

24 POINT

8 A 10 a \$4 00

ALEXANDER HAMILTON
When in the course of time
it became necessary for one
people to dissolve the 9076

18 POINT

10 A 16 a \$3 25

DECLARE OUR INDEPENDENCE
When, in the course of time, it will
be found necessary for one people to
dissolve the bands which have 456

14 POINT

12 A 18 a \$3 25

EQUAL STATION AMONG THE POWERS
When, in the course of human events, it be-
comes necessary for one people to dissolve
the political bands which connect them with
another, and to assume, among the 1236890

Lining Figures only furnished with regular fonts. Old Style Figures furnished in separate fonts

DE VINNE SERIES

12 POINT

16 A 20 a \$3 00

PROCLAIM LIBERTY THROUGHOUT THE LAND

When, in the course of human events, it becomes necessary for one people to dissolve the bands which have connected them with another, and to assume, among the powers, the separate and equal station to which the laws of nature and of nature's God entitle them, a decent respect to the opinions of mankind 809

10 POINT

20 A 26 a \$2 75

THE BASIS FOR THE CONSTITUTION OF THE UNITED STATES

When, in the course of human events, it becomes necessary for one people to dissolve the political bands which have connected them with another, and to assume, among the powers of the earth, the separate and equal station to which the laws of nature and of nature's God entitle them, a decent respect to the opinions of mankind requires that they should declare the causes which impel them to the separation. We hold these truths to be self-evident 978

8 POINT

22 A 30 a \$2 50

REVOLUTIONARY CONVENTIONS

When, in the course of events, it becomes necessary for one people to dissolve the political bands which have connected them with another, and to assume, among the powers of the earth, the separate and equal station to which the laws of nature and of nature's God entitle 315789

7 POINT

22 A 34 a \$2 50

PROCLAIMS SELF-EVIDENT TRUTHS

When, in the course of human events, it becomes necessary for one people to dissolve the political bands which have connected them with another, and to assume, among the powers of the earth, the separate and equal station to which the laws of nature and of nature's God entitle them, a decent respect to the opinions of mankind requires that 86

6 POINT

24 A 36 a \$2 25

RIGHTS OF THE COLONIES RESERVED

When, in the course of human events, it becomes necessary for one people to dissolve the political bands which have connected them with another, and to assume, among the powers of the earth, the separate and equal station to which the laws of nature and of nature's God entitle them, a decent respect to the opinions of mankind requires that they should declare the causes which impel them to the separation. We hold 2560

5½ POINT

24 A 36 a \$2 50

GIVING FREEDOM AND INDEPENDENCE

When, in the course of human events, it becomes necessary for one people to dissolve the political bands which have connected them with another, and to assume, among the powers of the earth, the separate and equal station to which the laws of nature and of nature's God entitle them, a decent respect to the opinions of mankind requires that they should declare the causes which impel them to the separation. We hold these truths to be self-evident, that all men 2345

DE VINNE CONDENSED

72 POINT

4 A 5 a \$15 00

DESIGNER
Requesting

60 POINT

4 A 5 a \$10 00

HORSEMEN
Scare Riders

54 POINT

4 A 5 a \$7 50

BURNISHERS
Found Advice

DE VINNE CONDENSED

48 POINT

4 A 5 a \$6 00

HOME COMING
Member Desires
Song of Evening

42 POINT

4 A 6 a \$5 50

WOMEN SEARCH
Engage Children to
Recite Good Poems

36 POINT

5 A 8 a \$5 00

STUDENTS REBUILD
Exercising to Develop
the Muscles of Wrists

DE VINNE CONDENSED

30 POINT

6 A 9 a \$4 50

FREEDOM AND LIBERTY
When, in the course of time
it seems necessary for one
people of equal station 1475

24 POINT

8 A 12 a \$4 00

SUFFERINGS OF THE COLONIES
When, in the course of human life,
it becomes necessary for one people
to dissolve the political band which
connected them with another 1392

18 POINT

10 A 16 a \$3 25

OUR PROTEST AGAINST UNJUST TAXES
When, in the pursuit of human events, it
becomes necessary for one people to break
the political bands which have joined them
with one another, and to assume, among the
powers of the earth, the separate and 7986

DE VINNE CONDENSED

14 POINT

12 A 20 a \$3 25

LONG FOLLOWING OF ABUSES AND USURPATION

When, in the course of human incidents, it becomes necessary for one people to break the political bands which have connected them with one another, and to assume, among the powers of the earth, the separate and equal station to which the laws of nature 1947

12 POINT

18 A 22 a \$3 00

ALTERING FUNDAMENTALLY THE FORMS OF GOVERNMENT

When, in the course of human events, it becomes necessary for one people to dissolve the political bands which have connected them with one another, and to assume, among the powers of the earth, the separate and equal station to which the laws of nature and of nature's God entitle them, a decent respect to the opinions of mankind requires that they should declare the causes 5973

10 POINT

22 A 30 a \$2 75

TAKING AWAY OUR CHARTERS, ABOLISHING OUR MOST VALUABLE LAWS

When, in the course of human events, it becomes necessary for one people to dissolve the political bands which have connected them with one another, and to assume, among the powers of the earth, the separate and equal station to which the laws of nature and of nature's God sanction them, a decent respect to the opinions of mankind requires that they should declare the causes which impel them to the separation. We hold these truths to be self-evident, that all men are created equal; that they are endowed by their Creator with certain 1234567890

8 POINT

25 A 36 a \$2 50

SECURES CONSENT OF THE GOVERNED

When, in the course of human events, it becomes necessary for one people to dissolve the bands which connects them with another, and to assume, among the powers of the earth, the separate and equal station to which the laws of nature and of nature's God entitle them, a decent respect to the opinions of mankind requires that 71958

6 POINT

30 A 42 a \$2 25

LIFE, LIBERTY, AND THE PURSUIT OF HAPPINESS

When, in the course of human events, it becomes necessary for one people to dissolve the political bands which have connected them with another, and to assume among the powers of the earth the separate and equal station to which the laws of nature and of nature's God entitle them, a decent respect to the opinions of mankind requires that they should declare the causes which impel them to the separation. We hold these truths to be self-evident, that all men are created equal; that they are endowed by their Creator

DE VINNE EXTRA CONDENSED

PATENTED

72 POINT

4 A 5 a \$15 00

NOBLE Horses

60 POINT

4 A 5 a \$9 00

Brought **ROCKER**

54 POINT

5 A 7 a \$8 00

DURABLE Flooring

48 POINT

5 A 8 a \$7 00

Landscape **IMPROVED**

42 POINT

6 A 10 a \$6 00

MODERN CUISINE
Clothed in Deep Mystery

DE VINNE EXTRA CONDENSED

PATENTED

36 POINT

6 A 12 a \$5 50

COLLEGE MONTHS

Bright Maidens in Attendance

30 POINT

8 A 12 a \$5 00

NUMEROUS LANDMARKS

Throughout Cumberland Discovered

24 POINT

10 A 16 a \$4 00

INNUMERABLE REQUISITIONS

Administration Upholding Monroe Doctrines

18 POINT

12 A 20 a \$3 25

DISPLAY BEAUTIFUL FLORAL DESIGNS

Seventh Annual International Chrysanthemum Exhibit
Handsome Flowers Displayed

14 POINT

18 A 22 a \$3 25

NATIONAL CONVENTION

Mississippi Valley Metropolis

1 2 3 4 5 6 7 8 9 0

12 POINT

20 A 26 a \$3 00

VENEZUELAN COMMISSION

Arbitration Now Becomes Necessary

1 2 3 4 5 6 7 8 9 0

CUSHING OLD STYLE

48 POINT

4 A 6 a \$7 00

BASE SINGER
Musical Talent

36 POINT

5 A 8 a \$5 50

WINTER OPENING
Grand Blanket Sales

24 POINT

8 A 12 a \$4 50

FLOURISHING INDUSTRY
Symptoms Indicate Strongly
that Prosperity is Returning

18 POINT

12 A 16 a \$3 50

THRIVING MERCANTILE HOUSES
Occupation of Porto Rico Stimulated
Rivalry among the Leading Exporters

14 POINT

16 A 24 a \$3 25

DEMANDS FOR SEASONABLE CLOTHING
The Prevailing Cold Weather has given a New
Impetus to the Manufacture of Heavy Textiles

CUSHING OLD STYLE

12 POINT

20 A 30 a \$3 00

INDISPENSABLE FOR OUR PERMANENT GROWTH
 To the Efficacy of the Union a Government for the Whole is Essential. No Alliances, however strict, between the Parts can be substituted, as they must lead to Infractions or Interruptions which all the Alliances have Experienced

11 POINT

22 A 34 a \$2 90

BIRDS GUIDED COLUMBUS IN HIS GLORIOUS DISCOVERY
 Indications of Approaching Land became more certain, and excited Hopes in Proportion. Birds began to Appear in Flocks, flying in a Southwesterly Direction, and this induced Columbus to alter his Course toward the Quarter whither the Birds pointed their Flight

10 POINT

24 A 36 a \$2 75

THE MOST ADMIRABLE DISPOSITION OF BENJAMIN FRANKLIN
 His Characteristic Passion seems to have been the Love of Everything Useful. This was to him the Sublime and Beautiful, which he was in quest of Every Week for Fifty Years. No Department was too humble for him to occupy himself in for the Purpose of Looking for the Useful

9 POINT

28 A 42 a \$2 75

TRUE PRINCIPLE OF LIBERTY
 The Constitution is Obligatory upon all People. The Idea of the Power and the Right of the People to chose their own Government presupposes a Duty of Everybody to obey the Laws

7 POINT

26 A 40 a \$2 50

THE BEAUTIFUL YOSEMITE VALLEY
 About the Time of the Full Moon, and in May or June, according to the Forwardness of the Season, is the Time to enjoy in their Perfection the Glories of the Waterfalls, as the Snow has not yet gone from the Hills

1234567890

8 POINT

28 A 42 a \$2 50

JERUSALEM RUINED BY ZEALOTS
 If the Jews had yielded to the Liberal Spirit of Saint Paul, Jerusalem might have escaped its Awful Fate, and have survived with all its Splendor through the Centuries as the Head of the Church

6 POINT NO 1

24 A 36 a \$2 25

CONQUESTS OF THE KNIGHTS TEMPLARS
 The Knights, under the Grandmaster Foulkes de Villaret, in Conjunction with some Italian Crusaders captured Rhodes and seven adjacent Islands from the Greek Pirates and carried on from there a Fierce War against the Saracens

1234567890

FLORENTINE OLD STYLE No 2

72 POINT

4 A 5 a \$9 50

PRODUCED
Scare Head

48 POINT

5 A 5 a \$7 00

DISCOVER NICE
Shades
Planted

12 POINT

20 A 24 a \$3 75

SEASHORE and Mountain
Scenery is presented to
the traveler's gaze in most
charming variety. Only his
capacity to enjoy Nature in

24 POINT

10 A 10 a \$5 00

HAPPY CHILDREN
Fairy Boat Sailing

8 POINT

30 A 32 a \$2 75

DOWN THE RIVER

Dark brown is the river,
Golden is the sand,
It flows along forever,
With trees on either hand.
Green leaves a-floating,
Castles of the foam.

FLORENTINE OLD STYLE No 2

60 POINT

4 A 5 a \$9 00

DREAM FACE

Each 36 Bark

36 POINT

6 A 8 a \$6 00

PLEASANT MANSION

Fine \$2 Hats

Grow Useful

6 POINT

36 A 40 a \$2 50

NOVEMBER'S PARTY

November gave a party,
 The leaves by hundreds came
 The Chestnuts, Oaks, and Maples
 And leaves of every name.
 The sunshine spread the carpet
 And everything was grand;
 Miss Weather led the dancing
 Professor Wind the band.

10 POINT

25 A 32 a \$3 25

PROSPECTUS FOR THE NEXT
 SEASON WILL BE FOUND HERE

BEGINNING with the month
 of January the Magazine
 will print a series of Art
 Pictures delineating native life
 in the Philippines as it looks to
 an unimaginative New Yorkist

18 POINT

15 A 14 a \$4 50

SPRING OPENING

WEDNESDAY

Fine Eaton Jacket

Donated Gratis

BINNER GOTHIC

72 POINT

5 A 8 a \$9 00

FARMERS Inauguration

60 POINT

7 A 10 a \$8 00

Manufacturers EXPENDITURE

48 POINT

8 A 12 a \$7 00

DISTINGUISHED Artistic Thermometer

36 POINT

10 A 15 a \$6 00

MODERN RAILROAD
Delights Excursionists

30 POINT

12 A 18 a \$5 00

PERMANENT INVESTMENT
Eastern Historical Society

24 POINT

14 A 20 a \$4 00

BURNING ELEVATORS UNNOTICED
Mild Languor of Soft Brown Eyes

1234567890

18 POINT

18 A 27 a \$3 25

ADMIRER BEAUTIFUL FOLDING SLEEVES
Funeral Services Held Over Dead Soldiers

1234567890

PART VI.

**Standard
Jobbing Type**

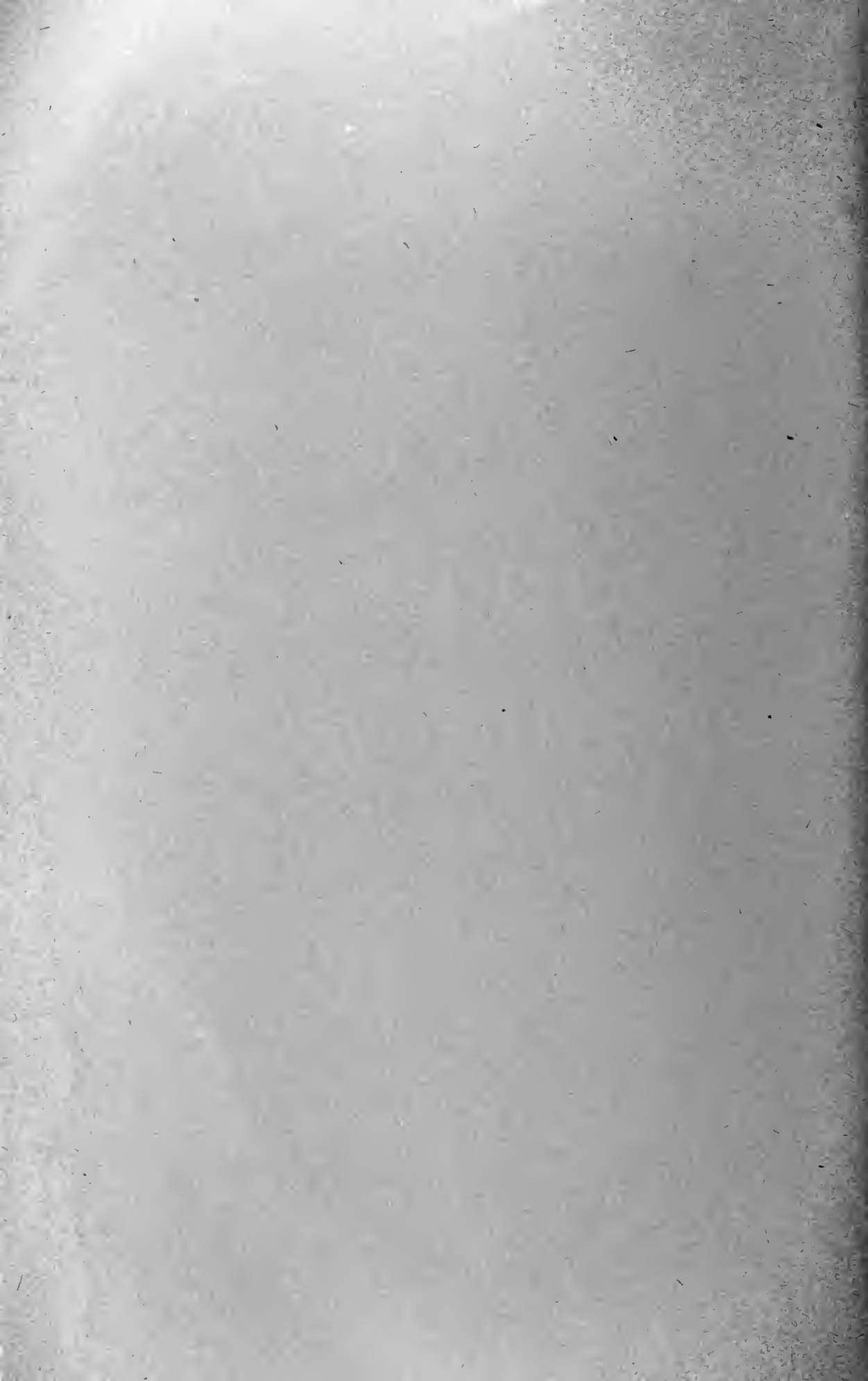

RONALDSON GOTHIC

48 POINT

5 A 7 a \$7 15

Pleasant DREAM

36 POINT

6 A 9 a \$5 80

Sugar CANDY Gratis

30 POINT

8 A 12 a \$4 95

OLDENTIME Observance

24 POINT

10 A 15 a \$3 70

Splendid PRESENTS Displayed

18 POINT

12 A 18 a \$3 15

OVERFLOWING
Family Blessings

14 POINT

18 A 28 a \$3 15

REMEMBERING
Mannerly Youngers

12 POINT

22 A 34 a \$3 10

AFTER DINNER
Boisterous Enjoyment
Shared by Adults

10 POINT

28 A 45 a \$3 10

MODEST MAIDENS
Courteous and Polite Girls
Womanhood Adored

8 POINT

38 A 55 a \$3 10

KRISS KRINGLE ANTICS
Wriggling Down Narrow Chimneys
1 2 3 4 5 6 7 8 9 0

6 POINT

40 A 60 a \$3 10

WELCOME AS SPRINGTIME
Opportunities to Please the Children
1 2 3 4 5 6 7 8 9 0

ELZEVIR GOTHIC

60 POINT

3 A 5 a \$11 50

GAMES
Fast Horses

48 POINT

3 A 6 a \$8 00

‡CHARM‡
Roman Guard

36 POINT

5 A 9 a \$6 00

MONUMENTS
Grandeur Described

30 POINT

6 A 12 a \$5 50

‡COUNCILMANIC‡
Independent Convention

ELZEVIR GOTHIC

24 POINT

8 A 16 a \$5 00

MOUNT VESUVIUS
Gorgeous Palaces Destroyed
Violent Eruption

18 POINT

12 A 24 a \$4 50

NATIONAL PREROGATIVE
Liberal Reform Movements Indorsed
Municipal Resolution

14 POINT

15 A 30 a \$4 00

FAMOUS ELOCUTIONISTS ENTERTAIN
Distinguished Orators Receive Congratulations
Linguistic Powers Unsurpassed

12 POINT

18 A 36 a \$3 50

£ NATIONAL CONVENTION CONSIDERED Ɔ
International Monetary Questions Frequently Discussed
Organization Committee Reports

10 POINT

20 A 40 a \$3 00

HANDSOME PREMIUMS AWARDED COMPETITORS
Collection of Botanical Specimens and Delicate Wild Flowers
Floricultural and Horticultural Exhibition

8 POINT

22 A 44 a \$2 75

IMPROVEMENT OF MANKIND
Advocating Protection for the Honest
Our Industrial Conditions
1 2 3 4 5 6 7 8 9 0

6 POINT

25 A 50 a \$2 50

MORALS OF THE GENERAL PUBLIC
Dawn of Civilization and Decrease of Crime
Modern Religious Thoughts
1 2 3 4 5 6 7 8 9 0

DUERER SERIES

PATENTED

72 POINT

3 A 5 a \$10 00

Golden HOURS

60 POINT

3 A 6 a \$9 00

HOUSE Burning

48 POINT

3 A 4 a \$6 00

Prominent ACTORS

36 POINT

5 A 7 a \$4 75

GRANITE
Monuments

24 POINT

8 A 11 a \$4 00

CHRISTMAS
Holiday Presents

18 POINT

11 A 16 a \$3 25

IMPROVEMENTS
Neatness and Dispatch
Promptness 35

12 POINT

18 A 24 a \$3 00

HONORED VISITORS
Elaborate Receptions Tendered
Refreshing \$614

WASHINGTON SERIES

PATENTED

60 POINT

4 A 5 a \$15 00

RICH Man

54 POINT

4 A 5 a \$10 50

Dear GAME

48 POINT

4 A 5 a \$10 00

FRIED Crabs

42 POINT

4 A 6 a \$7 25

Best NEW Dish

36 POINT

5 A 8 a \$6 75

TIN Pan

30 POINT

6 A 8 a \$5 25

Flat RIMS

24 POINT

8 A 10 a \$4 50

Daily RIDES

18 POINT

9 A 13 a \$3 50

NOVEL Whalers

12 POINT

12 A 18 a \$3 00

FISHERMAIDEN
Handsome Companion

10 POINT

16 A 22 a \$2 75

SAILING EXCURSION
Midnight Trip Advertised

8 POINT

18 A 24 a \$2 50

ENCAMPMENT CUISINE
Palatable Dainties Served Gratis

6 POINT

22 A 32 a \$2 25

DELIGHTFUL EVENING PASTIME
Repairing Fishing and Gunning Equipment

1 2 3 4 5 6 7 8 9 0

1 2 3 4 5 6 7 8 9 0

JEFFERSON SERIES

PATENTED

60 POINT

4 A 5 a \$11 00

POLAR Perils

54 POINT

4 A 5 a \$8 50

Land POINTER

48 POINT

4 A 6 a \$7 75

TEN Cat

42 POINT

4 A 6 a \$6 25

Fat BOYS

36 POINT

5 A 7 a \$5 75

Gold MINE

30 POINT

6 A 8 a \$4 75

OCEAN Sailor

24 POINT

8 A 10 a \$4 50

SKATING Drills

18 POINT

10 A 14 a \$3 25

Famous PUBLICATION

12 POINT

16 A 24 a \$3 00

CONGRESSIONAL NOTES
Bright Entertaining Gentlemen

10 POINT

20 A 28 a \$2 75

MARINERS DELIGHTED
When Land is Sighted after Six Months

8 POINT

24 A 32 a \$2 50

CHARMING AND HANDSOME MAID
Exciting Football Games on the Pastime Grounds

6 POINT

26 A 38 a \$2 25

PROPOSED NEW AMENDMENTS TO THE
Constitution of United States for Emancipation of Base Ball Slaves

LAFAYETTE SERIES

PATENTED

72 POINT

4A 5a \$9 50

STRONG Drinker

60 POINT

4A 6a \$7 50

Morning SUNSHINE

54 POINT

4A 6a \$7 00

HANDSOME Butterfly

48 POINT

6A 8a \$7 00

Watchman EXCELLENT

42 POINT

6A 9a \$6 25

DARK Nights

36 POINT

8A 10a \$5 75

NUDE Figures

30 POINT

9A 12a \$5 00

Lucrative PLACES

24 POINT

10A 14a \$4 00

Favorable PASTIME

18 POINT

12A 18a \$3 25

IMPETUOUS Philanthropy

12 POINT

20A 30a \$3 00

CORRESPONDING 54 Predicaments

VIRILE SERIES

PATENTED

60 POINT

4 A 6 a \$7 50

OPENING Season

48 POINT

6 A 8 a \$6 50

Bountiful HARVESTS

36 POINT

6 A 10 a \$6 00

SLAUGHTERED Buffaloes

30 POINT

8 A 12 a \$5 50

Mexican VOLCANIC Eruptions

24 POINT

10 A 16 a \$4 00

BENEVOLENT GATHERINGS
Honorable and Charitable Associations

18 POINT

12 A 20 a \$3 50

STRONG WIND
Natural Flower Odors
12345678

12 POINT

16 A 30 a \$3 00

PLEASING PRODUCTS
Designed for Modern Printers
1234567890

QUAINT SERIES

PATENTED

48 POINT

4 A \$4 00

GRAND · JOKER

36 POINT

6 A \$3 40

EVENING · SERMON

24 POINT

8 A \$2 90

THIRD · NATIONAL · BANK

18 POINT

10 A \$2 25

STRONG · AND · HEARTY
HISTORIC · CHESTNUT · SOCIETY

12 POINT

14 A \$1 90

REVIEWING GRAND PARADE
PHILADELPHIA · VETERAN · ASSOCIATION

10 POINT

20 A \$1 90

GOLD · AND · SILVER
RICH DIAMOND FIELDS
· 1 2 3 4 5 6 7 8 ·

8 POINT

24 A \$1 90

HUMPT · & · DUMPT
DEALERS AND FURNISHERS
· 1 2 3 4 5 6 7 8 9 0 ·

ERRATICK SERIES

PATENTED

48 POINT

4 A 5 a \$7 50

SUPERB
Style 4 Boats

42 POINT

4 A 6 a \$6 00

Expert SONG 5

30 POINT

6 A 8 a \$5 50

GRAND 2 Bargains

24 POINT

8 A 12 a \$4 00

BARTON
Historians 2

18 POINT

10 A 18 a \$3 50

MEXICANS
Grand 9 Sports

12 POINT

14 A 24 a \$3 00

ACTORS FANCY
Designed 8 Engraved

10 POINT

16 A 32 a \$2 75

ELEGANT ROSES
That Bloom in Spring 12

8 POINT

20 A 32 a \$2 50

MONROE DOCTRINE
Uncle Samuel Laying Plans 7

6 POINT

20 A 40 a \$2 25

BOULEVARDS SPRINKLED
German Band 29 Exquisite Melodies

QUAINT ROMAN No 2

48 POINT

4 A 5 a \$11 00

Great RISE

36 POINT

4 A 6 a \$8 50

ANCIENT
Nubian Builder

24 POINT

6 A 8 a \$5 00

HISTORIANS
Charming and Reliable

18 POINT

8 A 10 a \$4 50

MODERN CUSTOMS
Inaugurated by Academician

12 POINT

14 A 16 a \$3 25

ENDORSEMENT
Rejoicing Projectors
I 2 3 4 5 6 7

10 POINT

14 A 18 a \$3 00

MEXICAN EDITION
Original Fashion Designs
I 2 3 4 5 6 7 8 9 0

EPITAPH SERIES

48 POINT

3 A \$6 00

MARCHED 2

36 POINT

5 A \$4 25

HORSES DRIVEN

24 POINT

7 A \$3 25

**FRIENDS & EULOGIZED
 DEPARTED**

18 POINT

9 A \$2 50

**JOINT DEBATE AND FALSE TALKS
 EXCHANGING PRODUCE**

12 POINT

14 A \$2 25

**PERIODICAL CIRCULATIONS
 WHISTLING HURRICANES TURNING PYRAMIDS
 1234567890**

EREBUS SERIES

PATENTED

60 POINT

4 A \$5 75

**MANY COLORS
GRAND HOUSE**

48 POINT

5 A \$4 50

**HANDSOME FACE
PLEASE MAIDEN**

36 POINT

6 A \$3 50

**DEDICATE TO NOBLES
HIGHEST MONUMENTS**

24 POINT

8 A \$2 25

**ROMANESQUE MUSICAL CADENCE
465 MAGNIFICENT BANQUETS 132**

Hades, registering with this series, is shown on page 469. See page 453 for specimen in two colors

RUBENS SERIES

PATENTED

72 POINT ^E

5 A 6 a \$10 25

SUMMER Fashions

60 POINT ^E

4 A 7 a \$7 50

Extraordinary DISPLAY

54 POINT ^A

6 A 6 a \$6 75

STUMP ORATORS
Debating Silver Question

48 POINT ^E

6 A 8 a \$6 00

EVENING CONCERT
Original Burlesque Company

RUBENS SERIES

PATENTED

42 POINT

7 A 10 a \$5 50

GENTLEMEN ESTABLISH
Modern Reform Municipal League

36 POINT

8 A 12 a \$5 00

MONUMENT ASSOCIATION
Contributions from Patriotic Volunteers

30 POINT

10 A 14 a \$4 50

ORGANIZED BANKING COMPANIES
Autocratic Millionaires Purchasing Securities

24 POINT

12 A 18 a \$4 25

PURLOINED KISSES IN TUNNELS
Compressed Sweetness Between Lightning Fleetness

18 POINT

12 A 24 a \$3 25

DURABLE AND NEAT
Reversible Seamless Overcoat
Practical 517 Gift

12 POINT

22 A 36 a \$3 00

MUSCULAR ENDURANCE
Entertainments in Gymnastic Contests
Athletic 298 Game

ROUNDHEAD SERIES

48 POINT

3 A 4 a \$5 80

**Parsimonious
Despised and Rejected**

36 POINT

4 A 5 a \$4 45

**Recommendable
Calisthenical Entertainment**

24 POINT

8 A 10 a \$3 70

**Curbstone Amusements
Political Parades and Marching Soldiers**

18 POINT

10 A 12 a \$3 15

**Fashionable Damsels Indignant
Manufacture and Sale of Face-powders Prohibited**

12 POINT

12 A 16 a \$2 25

**Bulletin Dispatchers
Telegraph, Phone and Associates
1 2 3 4 5 6 7 8 9 0**

9 POINT

14 A 20 a \$2 00

**Herself the Foremost Beauty
Practical Instruction for Self-Glorification
1 2 3 4 5 6 7 8 9 0**

KITCAT SERIES

48 POINT

3 A 4 a \$6 00

CHOICE PEARS
Finest Confection

36 POINT

4 A 5 a \$4 15

BUCKING BRONCHO
Horses Broke Carriage

24 POINT

6 A 8 a \$2 85

REMUNERATE MACHINISTS
Agreeable · Work *and* Prompt · Pay

18 POINT

8 A 12 a \$2 45

RAILROAD EXCURSION DESPATCHED
Summer Tourists Become Winter Travelers

12 POINT

10 A 14 a \$1 55

BOSTON CREDIT HOUSE
Selling · Household · Articles
At · Reasonable · Prices · 314

9 POINT

12 A 16 a \$1 25

OWNERS ERECTING BUILDING
More · than · One · Hundred · Thousand
Handsome · Apartment · Houses · Can
Be · Purchased · in · Oceanville · \$208

End Ornaments and Logotypes   *and*  *furnished with all sizes*

POLO SERIES

60 POINT

3 A 5 a \$9 30

Demonstration

48 POINT

4 A 6 a \$7 20

Histrionic Exercise

36 POINT

5 A 10 a \$5 90

Sapient Juveniles
Candid Novices Rejoice

24 POINT

8 A 16 a \$4 35

Handsome Diplomas
Distinguished Scholars Rewarded

18 POINT

10 A 20 a \$3 55

Generous Teachers Delighted
Profound Thanks Expressed by Graduates

1 2 3 4 5 6 7 8 9 0

LONGFELLOW SERIES

72 POINT

3 A 6a \$12 00

Broken Carriage

60 POINT

4 A 9a \$11 00

Educate the Minor

54 POINT

4 A 9a \$10 00

Theorists

48 POINT

4 A 10a \$9 00

Marriages

42 POINT

4 A 10a \$8 00

Researches

36 POINT

4 A 12a \$7 00

Enchantment

30 POINT

5 A 14a \$6 00

Warlike Errand

24 POINT

7 A 16a \$5 00

Advanced Thinkers

18 POINT

9 A 22a \$4 50

Removing the Wreckage

12 POINT

14 A 40a \$4 00

Expedition Starting for Iceland

10 POINT

14 A 40a \$3 50

Surveyors Dispel Senseless Theories
1234567890

8 POINT

14 A 40a \$3 00

Stupendous Undertakings Accomplished
1234567890

CHILDS SERIES

PATENTED

60 POINT

3 A 5 a \$10 65

OUR Guard

48 POINT

4 A 6 a \$8 35

Hold the FORT

36 POINT

5 A 8 a \$6 30

GRAND Manœuvre

30 POINT

6 A 9 a \$5 15

STOUT
Conscripts

24 POINT

8 A 12 a \$4 50

DARING
Skirmishers

18 POINT

12 A 18 a \$4 10

AMAZONS
Robust Warriors
123456

12 POINT

20 A 30 a \$3 60

UNBLUSHING
Regimental Daughters
12345678

JOHNSON SERIES

PATENTED

60 POINT

3 A 5 a \$9 60

Grand Jaunts

48 POINT

3 A 6 a \$7 60

Beautiful Scenes

36 POINT

4 A 8 a \$6 20

Gorgeous Landscape

30 POINT

5 A 10 a \$5 75

Crossing the Mountains

24 POINT

6 A 12 a \$5 05

Tourists Enjoying the Sport

18 POINT

8 A 16 a \$4 35

Running Up Hills and Down Valleys

1234567890

MORTISED SERIES

PATENTED

48 POINT

3 A \$5 70

MORTISED

36 POINT

5 A \$4 30

VANISHMENT

24 POINT

9 A \$3 00

PATERNAL REGARD

18 POINT

12 A \$2 50

PATRIARCH

12 POINT

18 A \$2 10

RURAL HOMES

9 POINT

22 A \$1 80

WHITE ELEPHANTS

12345678

6 POINT

25 A \$1 45

YOUTHS DECORATE GRAVES

1234567890

EUREKA ALPHA CIRCLE

FROSTED COUGH LOZENGES

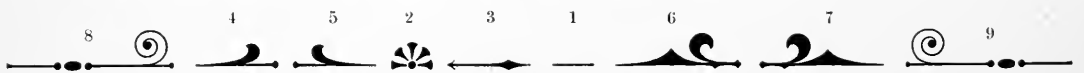

Furnished with the 48 Point size only

The letters C E F L Q and T are made each in two distinct widths in the 24, 36 and 48 Point sizes

STANDARD LINING ANTIQUE

30 POINT

6 A \$3 75

BEAUTIFUL
CUBAN GIRLS

24 POINT

8 A \$3 40

PROGRESSIVE
BOXING TEACHER

18 POINT

10 A \$2 70

AMERICAN SAILORS
STRONG GOVERNMENT

12 POINT No 3

20 A \$2 80

MIDSUMMER
NIGHT DREAMS

12 POINT No 2

20 A \$2 30

SECOND-HAND
SEWING MACHINE

12 POINT No 1

20 A \$2 00

MOUNTAIN CLIMBER
ROMANTIC ENTERTAINER

6 POINT No 5

30 A \$1 75

TINWARE MERCHANDISE
MANUFACTURER AND JOBBER

6 POINT No 4

30 A \$1 50

LAUGHING BABBLING BROOK
SPRING AND SUMMER ARE COMING

6 POINT No 3

30 A \$1 25

PRESENT DIFFICULTY ACCEPTED
MOONLIGHT RAMBLING ON THE BEACH

6 POINT No 2

30 A \$1 25

PENSIVELY LOOKING BACKWARD
EXALTED THOUGHTS AND WORTHY BEHAVIOR

6 POINT No 1

35 A \$1 25

NINE COLORED SATINS AND GOODS
ARRIVING DAILY ON THE STEAMSHIP INTERNATIONAL

ALASKAN SERIES

48 POINT

3 A \$7 30

BONDS

36 POINT

4 A \$8 00

MACHINE

24 POINT

6 A \$4 50

REMOVE
RURAL TRACK

18 POINT

8 A \$3 65

PURCHASE
NOBLE 56 RACER

12 POINT

10 A \$2 05

REMOTE
RESORT QUIET

10 POINT

12 A \$1 70

THUNDER
STORMS PRODUCE

8 POINT

16 A \$1 70

SOUND BOATS
WEALTH NOT ACQUIRED
654 VERY EASILY

6 POINT

24 A \$1 50

RELIABLE SECURITY
PEOPLE DESIRING HOME COMFORTS
FORMING GREATER 3456

ATLANTA SERIES

48 POINT

4 A \$10 00

SOURS

42 POINT

4 A \$7 25

MOVER

36 POINT

4 A \$6 75

MINDING

30 POINT

5 A \$5 00

GERALINE

24 POINT

6 A \$4 50

GRAB ❖ BAGS

18 POINT

8 A \$3 50

❖ STING ❖

14 POINT

9 A \$3 25

❖ CROAKS ❖

12 POINT

12 A \$3 00

GOOD ❖ DOGS

10 POINT

16 A \$2 75

SWEET ❖ MUSIC

8 POINT

20 A \$2 50

❖ CALLED · LOUDEST ❖
1234567890

6 POINT

28 A \$2 25

❖ COURAGEOUS · DEFENDER ❖
1234567890

VICTORIA SERIES

48 POINT

5 A \$8 50

VICTORIA

42 POINT

6 A \$7 25

CONSTRUE

36 POINT

6 A \$6 75

✻ SPURNED ✻

30 POINT

7 A \$5 00

CAPITAL · RING

24 POINT

8 A \$4 50

BANKER LIMITED

18 POINT

10 A \$3 50

SPARROWS

14 POINT

12 A \$3 25

CONJUNCTIVE

12 POINT

16 A \$3 00

KINDLY ✻ WORDS

10 POINT

20 A \$2 75

TENDER ✻ AFFECTION

8 POINT

28 A \$2 50

✻ CHEERING ✻ RECEPTION ✻

6 POINT

36 A \$2 25

✻ UNRULY ✻ CHILDREN ✻ PUNISHED ✻

1234567890

1234567890

TRINAL—Series Three

48 POINT

3 A \$6 25

ROSEBUD

36 POINT with 48 Point Initial 4 A \$5 40 3 A \$5 00

24 POINT with 36 Point Initial 6 A \$4 40 3 A \$3 50

EAST HONEY

TRINAL—Series Two

36 POINT

4 A \$4 40

GOLD MINER

28 POINT with 36 Point Initial 6 A \$4 25 3 A \$2 60

20 POINT with 28 Point Initial 8 A \$3 65 4 A \$2 10

ROMAN MEADOW

TRINAL—Series One

24 POINT with 36 Point Initials

INITIALS
6 A \$3 00 3 A \$2 60

NORTH 54 TIMBER

18 POINT with 24 Point Initial 8 A \$2 85 3 A \$1 50

INITIALS
12 POINT with 18 Point Initials 10 A \$2 50 4 A \$1 15

WEATHER FIFTH NOTE

A B C D G J K L

HOUGHTON SERIES

60 POINT

3 A 4 a \$11 90

Refreshment

48 POINT

3 A 5 a \$9 25

Strong Acrobat

36 POINT

3 A 7 a \$7 50

Interesting Farcical

24 POINT

4 A 10 a \$4 50

Aeronauts Descend Quickly

ELBERON No 2

36 POINT

4 A 6 a \$8 80

GREAT Romans

24 POINT

6 A 10 a \$6 70

Unruly Child TEACHER

18 POINT

8 A 14 a \$5 25

DARK CLOTH
Mark 85 Price

12 POINT

10 A 18 a \$3 90

IMPROVED PRESS
Highly 74 Warranted

TYPO SERIES

60 POINT

3 A 4 a \$7 00

CRADLE Nonsense

48 POINT

4 A 6 a \$5 25

Grenadines LAUNDRIED

36 POINT

5 A 7 a \$4 70

FISH Market

30 POINT

6 A 9 a \$3 55

LARGE Cushion

24 POINT

8 A 10 a \$2 85

Broken 26 PLEDGE

18 POINT

10 A 14 a \$2 40

Hunting 58 FRANCHISE

CRUIKSHANK SERIES

36 POINT

3 A 6 A \$5 80

ENTERING

30 POINT

4 A 8 A \$5 15

PROSPERITY

24 POINT

5 A 12 A \$4 65

MORAL DEEDS

18 POINT

6 A 14 A \$3 85

NATIONAL REFORM

12 POINT

10 A 25 A \$3 30

RELEGATED TO OBSCURITY

1 2 3 4 5 6 7 8 9 0

9 POINT

10 A 28 A \$2 70

PROTECTION TO THE INDUSTRIOUS

1 2 3 4 5 6 7 8 9 0

SKJALD SERIES

PATENTED

60 POINT

Lower Case \$4 45 4 A 5 a \$10 35

HUNDRED

Mexican 46

48 POINT

Lower Case \$3 25 4 A 5 a \$8 65

GOOD FINES

Bold 28 Action

36 POINT

Lower Case \$3 00 6 A 8 a \$7 50

HONEST HEART

Strong 75 Friends

SKJALD SERIES

PATENTED

24 POINT

Lower Case \$2 00 8 A 10 a \$5 50

UNITE GOOD WORKS
Polish Crude Statues \$64

18 POINT

Lower Case \$2 00 10 A 14 a \$5 00

VIEW GRAND DESIGN
Notice Remarkable 92 Feature

12 POINT

Lower Case \$1 70 14 A 24 a \$4 00

ITALIAN WORKMANSHIP ENVIED
Michael Angelo Shaped Many Artistic Tombs 45

10 POINT Lower Case \$1 50 16 A 32 a \$3 50

BOLD CORINTHIAN IDEAS
Admirable Facades
Marks Grecian Architecture 96

8 POINT Lower Case \$1 10 18 A 32 a \$3 00

AMERICAN SCULPTORS PRAISE
European Masterpieces
Massive Vineclad 798 Marble Column

Printers having the Typothetæ need buy only Skjald lower case. Caps are identical

TYPOTHETÆ

16 POINT

12 A \$2 60

LARGE GRANITE BLOCK
CARVED WITH \$68 SHARP TOOLS

LINCOLN SERIES

60 POINT

3 A 6 a \$7 25

NOVEL Counters

48 POINT

4 A 9 a \$6 00

Durable MACHINES

42 POINT

4 A 8 a \$5 00

THEATRE Frequenter

36 POINT

5 A 10 a \$4 75

NEW BAIT
Small Frogs

30 POINT

6 A 12 a \$3 75

GOMIG SONG
Glancy's Goats

24 POINT

6 A 16 a \$3 50

BOSTON MAIDS
Liberal Delegates

18 POINT

10 A 20 a \$2 75

BURLESQUE SHOW
Joyful Voices Rising

12 POINT

12 A 24 a \$2 25

EXCEPTIONAL ADVANTAGE
Granted to Summer Customers
1234567890

10 POINT

20 A 40 a \$2 00

DIRECT TELEGRAPHIC CONNECTION
Reviewing Descriptive News of Spain
1234567890

DOUGLAS SERIES

48 POINT

3 A 6 a \$6 25

RENT Receipts

42 POINT

3 A 6 a \$5 00

Gostume DESIGN

36 POINT

4 A 8 a \$4 90

NURSE 85 Granted

30 POINT

6 A 12 a \$5 45

FOREIGN STONE
Assortment Monuments

24 POINT

8 A 16 a \$4 30

SUN FISH
Large Dealer

18 POINT

10 A 20 a \$3 30

AMBITIOUS
National Guards

12 POINT

12 A 24 a \$2 10

GOLD SHIPMENT
Enterprising Prospector
1234567890

10 POINT

18 A 36 a \$2 40

DELIGHTFUL MUSIC
Egyptian Selections Rendered
1234567890

ARCHAIC SERIES

36 POINT

7 A 10 a \$6 00

FRIENDLY DEALING
Houses can be bought
at terms of Purchaser

12 POINT

25 A 40 a \$3 10

SALE WHICH IS OF INTEREST TO EVERYBODY

WE beg to announce that we have engaged the services of Mr. F. Dawson, the well-known decorative artist, to design and execute all kinds of Interior Decorative Work, including Woodwork, in the artistic manner for which he has the highest reputation. His superb stock has been bought by us, and is now on exhibition

FAIR, DEALER & COMPANY

'Phone 2345

Cor. Broad and Center St.

30 POINT

8 A 14 a \$5 00

ENAMELED BEDSTEADS
Bargain sale of Furniture
will commence on Friday
Afternoon at 2.30 o'clock

ARCHAIC SERIES

24 POINT

10 A 18 a \$4 25

DESIRABLE LOT OF FABRICS
Remnants of Dress Goods will be for sale at Second Counter, Northern Aisle, and it will pay to look at them... 234 Patterns

9 POINT

30 A 50 a \$2 90

SALE OF FANCY POTTERY

Our sale of China, Cut Glass and Bric-a-Brac commences to-day. The main and cross aisles of the first floor are filled from end to end this morning with an extensive showing of Decorative and Table Wares of new design

A. MERCHANT

289 Elbow Lane, Troy, O.

6 POINT

36 A 70 a \$2 70

BARGAINS IN BOYS' FURNISHINGS

Now is the time to get boys rigged out for school, and it will be an easy task for mothers if they will pay us a visit and look over our large stock of Clothes, which are sold at prices within reach of all. Double-breasted Suits, of all-wool fancy chevots and cassimeres, medium and dark colors in gray and brown, in checks, over-plaids and plaids. Coats are lined with satin, and finished equally as well as those costing \$8.75 or more

BOIES, OUTFITTER & CO.

6238 Fourth Avenue

18 POINT

14 A 26 a \$3 75

PRETTY DRAPERIES FOR THE PARLOR
Choosing in Lace Curtains from our stock is safely satisfactory, because we always exercise great care in selecting patterns. We have picked carefully the best styles, and are selling about 1250 pairs every day

COLUMBIAN SERIES

PATENTED

60 POINT

3 A 5 a \$7 95

Riverside Tramways

48 POINT

4 A 6 a \$6 70

Advantageous Movement

42 POINT

5 A 10 a \$6 00

Portraying Domestic Industry

30 POINT

6 A 16 a \$5 10

Pictures of the Gigantic
Columbian Exposition Viewed Hourly

24 POINT

8 A 28 a \$4 40

Celebrating the Landing of Columbus
Display of American and European Handicraft

1 2 3 4 5 6 7 8 9 0

ART GOTHIC

PATENTED

72 POINT

3 A 5 a \$10 00

Reform School

60 POINT

4 A 5 a \$9 20

Fraternal Artists

48 POINT

4 A 5 a \$6 50

Carnival Excursions

36 POINT

6 A 8 a \$5 00

Merchandise Undervalued

24 POINT

8 A 10 a \$4 00

Indisputable Fence-rail Philosopher

18 POINT

12 A 16 a \$3 00

Unfounded Aristocracy Degenerating Hypocrites

12 POINT

14 A 20 a \$3 00

Merry Midway Pleasance Girl

1234567890

10 POINT

18 A 28 a \$2 75

Proposed Aerial Trips Postponed

1234567890

DYNAMO SERIES

48 POINT

3 A 4 a \$4 55

PENSIONS Received

36 POINT

4 A 6 a \$3 60

Government EXPANSION

24 POINT

8 A 10 a \$3 00

RAILROAD EXCURSION
Around the Continents Gratuitously

18 POINT

10 A 14 a \$2 45

INDUSTRIAL
Proceeds Distributed
1 2 3 4 5 6 7 8

12 POINT

16 A 25 a \$2 25

TELEGRAPHING
Messages Between Gallants
1 2 3 4 5 6 7 8

WALTON SERIES

36 POINT

4 A 8 a \$4 15

Handsome 6 SERIES Furnished

30 POINT

5 A 10 a \$3 65

Magnificent Christmas PRODUCTION

24 POINT

6 A 12 a \$3 15

SECOND 435
Dividends Purchased

18 POINT

8 A 16 a \$2 85

PROBLEM 578
Remarkable Performance

FOSTER GOTHIC

48 POINT

4 A \$4 75

NORTH RANGE

36 POINT

6 A \$4 25

HUNTS 586 BEARS

30 POINT

7 A \$3 75

REFORMED

24 POINT

8 A \$3 50

CUSTOMER

18 POINT

10 A \$2 75

PECULIAR
BANK 56 NOTE

12 POINT

14 A \$2 25

GATHERING
BEAUTIFUL BOUQUETS
CHRISTMAS 348

GOTH SERIES

24 POINT

12 A \$3 35

MERCHANT TAILORS

18 POINT

18 A \$3 15

BEAUTIFUL ART EXHIBITION

12 POINT

30 A \$2 65

FOREIGN TRADE

10 POINT

30 A \$2 25

GREAT ATTRACTION

8 POINT

40 A \$2 25

INDEPENDENT WORKER
1234567890

6 POINT

50 A \$2 00

UNSOPHISTICATED TRADESMEN
1234567890

MURAL SERIES

PATENTED

48 POINT

4 A \$5 25

MONUMENTS

42 POINT

5 A \$4 75

GRAND HEIGHT

36 POINT

6 A \$4 25

DUSTER AND BRUSH

30 POINT

6 A \$3 50

INCREASE EXERTION

24 POINT

8 A \$3 25

BEAMS REMAIN WHITE

20 POINT

9 A \$2 50

EXACT FORCE

18 POINT

10 A \$2 50

MAIDS KNOWN

12 POINT

18 A \$2 25

NUMEROUS REPORTS

10 POINT

20 A \$2 00

COMPLIMENTS REQUIRED

8 POINT

26 A \$1 75

MAGNIFICENT AND EXTRAORDINARY

6 POINT

26 A \$1 50

SPECIAL RATES FOR BOYS AND GIRLS

◁ 1 2 3 4 5 6 7 8 9 0 ▷

◁ 1 2 3 4 5 6 7 8 9 0 ▷

FACADE SERIES

PATENTED

60 POINT

5 A \$6 50

REQUIREMENT

54 POINT

5 A \$5 50

BRANCH ENGINE

48 POINT

5 A \$4 75

MOURNING HOURS

42 POINT

6 A \$4 25

DESCRIBE

36 POINT

8 A \$4 00

REDUCTION

30 POINT

9 A \$3 50

AMUSEMENTS

24 POINT

12 A \$3 25

CONSEQUENCES

20 POINT

16 A \$3 00

GENERAL RECORDS

18 POINT

18 A \$2 75

MORNING TELEGRAMS

12 POINT

25 A \$2 25

MANUFACTURING DEPARTMENTS

10 POINT

30 A \$2 00

REPAIRING ELECTRICAL INSTRUMENT

8 POINT

36 A \$1 75

ENORMOUS BARGAINS IN ARTISTIC FURNITURE

6 POINT

36 A \$1 50

MENAGERIES CONTAIN SOME REMARKABLE FEATURES

1 2 3 4 5 6 7 8 9 0

1 2 3 4 5 6 7 8 9 0

FACADE CONDENSED No 2

PATENTED

72 POINT

9 A 12 a \$13 50

Somnambulistic Excursion

60 POINT

12 A 16 a \$12 50

Modern Contrivance Desirable

54 POINT

12 A 16 a \$10 75

Remonstrations

48 POINT

12 A 16 a \$9 00

Unconscientious

42 POINT

14 A 18 a \$8 25

Generous Brothers

36 POINT

16 A 20 a \$7 00

Confidence Rewarded

30 POINT

16 A 20 a \$6 00

Government Examination

24 POINT

20 A 24 a \$5 00

Unbroken Promise Recorded

18 POINT

28 A 32 a \$4 75

Industrious Manufacturers Rewarded

16 POINT

30 A 34 a \$4 00

Americans Sending Largest Contribution

12 POINT

40 A 44 a \$3 75

Attention Given to Business Before Pleasure

10 POINT

46 A 50 a \$3 25

Revised Histories of Celebrated Discoveries Completed

1 2 3 4 5 6 7 8 9 0

1 2 3 4 5 6 7 8 9 0

FACADE CONDENSED

PATENTED

72 POINT

9 A \$7 25

VENTURESOME YOUNGESTER

60 POINT

12 A \$8 75

DEMANDS QUICK EXPERIMENTS

54 POINT

12 A \$6 00

AUTHORIZATION

48 POINT

12 A \$5 25

GOVERNMENTAL

42 POINT

14 A \$4 50

RESULT OBTAINED

36 POINT

16 A \$4 00

GRANKS WANDERING

30 POINT

16 A \$3 50

STATESMEN ASTOUNDED

24 POINT

20 A \$3 00

NOCTURNAL AMUSEMENTS

18 POINT

28 A \$2 75

LARGE CONTRIBUTIONS REQUESTED

16 POINT

30 A \$2 50

DANGEROUS HOMEWARD PROMENADE

12 POINT

40 A \$2 25

ANCIENT SCIENCES AND MODERN ETHOLOGY

10 POINT

46 A \$2 00

FOREIGN QUESTIONS NEVER INTRODUCED BEHINDHAND

1 2 3 4 5 6 7 8 9 0

1 2 3 4 5 6 7 8 9 0

LATIN CONDENSED No 150

72 POINT

4 A 6 a \$8 50

FURTIVE Fusiliers

60 POINT

5 A 6 a \$7 50

Evolution PLEASING

48 POINT

4 A 7 a \$5 00

DEMOLISHED Inclination

36 POINT

8 A 12 a \$4 25

PRACTICE
Skillful Person

30 POINT

10 A 15 a \$4 00

RECONCILED
Venturous Sailor

24 POINT

15 A 20 a \$3 75

BENEVOLENCE
Various Inconvenience

18 POINT

20 A 30 a \$3 25

REORGANIZATION
Defunct Building Associations

12 POINT

28 A 38 a \$3 00

BENEFICIAL PRESERVATION
Northern Peasants Build their Homes
1 2 3 4 5 6 7 8 9 0

10 POINT

36 A 50 a \$2 75

LAKE STEAMBOATS SPEEDING
Smooth Waters Allow Glorious Amusement
1 2 3 4 5 6 7 8 9 0

LATIN COMPRESSED No 30

48 POINT

6 A 10 a \$6 55

BLIND Horses

42 POINT

8 A 12 a \$5 75

REMONSTRATED
Political Orator

36 POINT

8 A 12 a \$4 45

SEVENTH EDITION
Railroad Quotation

24 POINT

10 A 15 a \$3 75

AMERICAN WEAPONS
National Introduction

18 POINT

15 A 20 a \$3 20

QUACK NOSTRUMS RELIEVE
Sensational Advertisements

12 POINT

20 A 30 a \$2 15

RELIABLE GOVERNMENT EMPLOYMENT
Internal Revenue Service Examination

1 2 3 4 5 6 7 8 9 0

O. S. LATIN CONDENSED

48 POINT

5 A 8 a \$4 85

RICH Miner

42 POINT

5 A 10 a \$4 15

HARMONIOUS
Peace Notices

36 POINT

8 A 12 a \$3 80

MODERN RANCH
Cuban Horsemen

24 POINT

12 A 20 a \$3 65

ALASKAN DIAMOND
Yukon River Hunter

18 POINT

20 A 30 a \$3 40

INDUSTRIAL SECURITIES
Columbus Machine Exhibit

12 POINT

25 A 40 a \$2 45

TENDEREST MEMORIES SILENCED
Ocular Institute for Blinded Lover

1 2 3 4 5 6 7 8 9 0

IVANHOE SERIES

36 POINT

4 A 5 a \$5 50

PARIS GREEN
Horse Race Lover

30 POINT

4 A 6 a \$5 25

BRAVE SOLDIER
Traveler Reciprocate

24 POINT

6 A 10 a \$4 75

ELEGANT SOUVENIR
Shareholder Divide Cigars

18 POINT

8 A 12 a \$3 75

RUSSIAN PRISON BUILDING
Entrancing Ethiopian Performances

12 POINT

Card Font 10 A 16 a \$2 40
Circular Font 25 A 125 a \$11 75

VOTERS ORGANIZE TO PROMOTE REFORMS
Movements to Remove Corrupt Politicians from Office

10 POINT

Card Font 10 A 18 a \$2 35
Circular Font 30 A 140 a \$11 85

ELECTRICAL STORM
Destroyed Handsome Edifice
1 2 3 4 5 6 7 8 9 0

8 POINT

Card Font 12 A 20 a \$2 40
Circular Font 36 A 150 a \$10 75

PRANKS OF LIGHTNING
Houses Unroofed and Trees Felled
1 2 3 4 5 6 7 8 9 0

OBELISK SERIES

60 POINT

3 A 5 a \$6 50

Perpetual REMAINS

48 POINT

4 A 6 a \$5 75

MUMMY TOMBS
Sphinxes and Monoliths

36 POINT

5 A 7 a \$5 15

MORNING STROLLS
Among Crumbling Architecture

24 POINT

7 A 10 a \$3 20

AUTOMOBILES
Seven Hours Ramble
123456

16 POINT

10 A 14 a \$2 50

EGYPTIAN RAILROAD
Unique Scenery Predominant
1234567890

ECCENTRIC SERIES

PATENTED

36 POINT

6 A \$3 50

FARMER · SELLING · CORN

24 POINT

8 A \$2 35

BOMBARDING · FORT · DELAWARE
ONSLAUGHT

18 POINT

10 A \$1 90

FORWARD · THEIR · MONTHLY · CONTRIBUTIONS
1234567890

CULDEE SERIES

PATENTED

24 POINT

4 A 8 a \$4 60

Whitewashing & Company

18 POINT

5 A 10 a \$3 80

Instructions in Outdoor Manners

12 POINT

8 A 16 a \$3 25

Future * Residence * Stone * Building * in * Suburbs

9 POINT

10 A 20 a \$2 80

Superiority * Economy * Promptness
Commercial Avenue and Business Street, Merchantsville

6 POINT

12 A 25 a \$2 55

Autumnal Meeting of Boreal Association
Inauguration of the Cyclone, Hurricane, Simoon, and Tornado Season

1234567890

PART VII.

LIGHTWEIGHT
DESIGNS

ELANDKAY SERIES

36 POINT

6 A \$3 25

CHARMING SERIES

24 POINT

8 A \$2 50

18 POINT No 29

12 A \$2 00

BEST SIZES

SPRING STYLE

18 POINT No 28

14 A \$1 75

12 POINT No 27

16 A \$1 50

DESIRE RETURNS

UNKNOWN COUNTRY

12 POINT No 26

18 A \$1 50

12 POINT No 25

24 A \$1 50

FAVORABLE CONDITION

NEW POOLING COMBINATION
LOST OPPORTUNITY

6 POINT No 24

30 A \$1 50

6 POINT No 23

30 A \$1 50

GREATER ADMIRATION EXPRESSED
CONTINUAL PROGRESS

FAMOUS AUTHOKRS WORKS ARE EXTINCT
XYLOGRAPHY AND PHOTOGRAPHY

6 POINT No 22

40 A \$1 25

6 POINT No 21

40 A \$1 25

EXPECTANCY OF ITS PROMOTERS
NO QUESTION HAS AROUSED MORE INTEREST
1 2 3 4 5 6 7 8 9 0

BEST MATERIAL AND WORKMANSHIP
MICROSCOPIC ADJUSTMENT OF TOOLS AND MACHINES
1 2 3 4 5 6 7 8 9 0

JAGGED SERIES

12 POINT No 39

12 A \$1 75

BRIGHTON FLORAL EXHIBITION
MANY FOREIGN PLANTS SHOWN

ORNAMENTS FOR THE
JAGGED SERIES

No 39



12 POINT No 40

14 A \$1 75

GRAND COACHING PARADE
A PLEASANT ANTICIPATION

No 40



12 POINT No 41

18 A \$1 75

MOST PICTURESQUE RESORT
SKOWHEGAN'S CELEBRATED HOSTELRIES

No 41



1 2 3 4 5 6 7 8 9 0

CAMELOT OLD STYLE

PATENT APPLIED FOR

36 POINT

10 a \$2 60 6 A 10 a \$5 50

SUPERIOR DESIGNS IN
 MODERN FURNISHING
 BY ORIGINAL DEALER

Nothing but
 results most
 satisfactory
 to customer

18 POINT

18 a \$1 95 12 A 18 a \$4 25

SOME MYTHICAL STORIES
 PRODUCED IN MINIATURE

For the edification of diminu-
 tive people in search of nice
 psychological specimens \$26

UNIQUE
 DESIGNS
 IN TYPE



AMERICAN
 TYPE FOUNDERS
 COMPANY

1900

CAMELOT OLD STYLE

PATENT APPLIED FOR

30 POINT

12 a \$2 35

8 A 12 a \$5 00

JOURNEYS NORTH OF THE
PEMAQUID RIVER DURING

CERT
LING

10 POINT

40 a \$1 95

18 A 40 a \$3 50

SOME TIME WHEN KING ARTHUR
HAD AFTER LONG WARS RESTED &
HELD ROYAL FEAST AND COUNCIL

BESIDE the Round Table, with his
allies of princes, noble knights
and all, there came to him, he
sitting on his throne royal, twelve
ancient men, bearing each of them
a branch of olive, in token that they
came as ambassadors and messen-
gers from the Emperor Lucius, who
was at that time called Dictator of
the Public Weal of Rome; which said
messengers after entering into the
presence of King Arthur, did to him
their obeisance, and said to him in
this wise: Our high and mighty
Emperor Lucius sendeth to the King
of Britain greeting, as commanding
thee to acknowledge him for thy
sovereign lord, and to send him the
truage due of this realm unto his

AMPS
SION

Holida

cords

of a Poet and Naturalist afoot
and awheel from May to July

See following pages

CAMELOT OLD STYLE

PATENT APPLIED FOR

12 POINT

36 a \$2 10 16 A 36 a \$4 00

FIVE HIGHEST AWARDS AT THE COLUMBIAN EXPOSITION
EXHIBITION OF MACHINERY, APPLIANCES AND PROCESSES
FOR THE MANUFACTURE OF MOVABLE METALLIC TYPES

Beginning with the perfectly constructed and minutely adjusted
Benton Punch-Cutting Machine, ending with the well designed
and highly efficient Barth Automatic Steam Power Type-Casting
and Type-Finishing Machine, in the production of copper alloy
type of correct proportions. Given at Chicago in the year 1893

AMERICAN TYPE FOUNDERS COMPANY

ORIGINATOR OF THE FASHIONS IN TYPE AND
UNIVERSAL PROVIDER TO THE PRINTING TRADE

LARGEST
MANUFACTURER
& DEALER IN THE
WORLD OF TYPE,
PRINTING OFFICE
MATERIALS, INKS
AND MACHINERY

COMPLETE OUTFITS
FURNISHED

8 POINT

44 a \$1 55 20 A 44 a \$3 00

THE LADY OF SHALOTT

On either side of the river lie
Long fields of barley and of rye,
That clothe the wold and meet the sky ;
And through the field a road runs by
 To many-towered Camelot.
And up and down the people go,
Gazing where the lilies blow
Round an island there below,
 The island of Shalott.

WILLOWS WHITEN AND ASPENS QUIVER
LITTLE BREEZES DUSK AND SHIVER THRO
The wave that runs forever by the island
in the river flowing down to Camelot.
Four gray walls and four towers overlook
a space of flowers and the silent isle em-
bowers the lady of Shalott. By a margin
willow veiled, slide the cumbrous barges
trailed by slow horses and unhailed the
shallop flitteth silken-sailed, skims \$45

CAMELOT OLD STYLE

PATENT APPLIED FOR

6 POINT 50 a \$1 40 24 A 50 a \$2 50

PROGRA

FIRST PART

- 1 GERMANIA MARCH
MANDOLIN CLUB
- 2 BALLAD The King a-Hunting Go
GLEE CLUB
- 3 MARY HOGAN'S BALL Ke
MR. O'MALLORY
- 4 DREAMS OF THE PAST
MANDOLINS
- 5 JUMBO CANTEPIC Newton
MR. FOSTER & CLUB
- 6 MAN BEHIND THE GUN Sousa
GUITAR CLUB
- 7 CAMPUS SONG F. F. Bullard
GLEE CLUB

THERE she weaves by night and day,
A magic web with colors gay.
She has heard a whisper say
A curse is on her if she stay
To look down to Camelot.
She knows not what the curse may be,
And so she weaveth steadily,
And little other care hath she,
The Lady of Shalott.

And moving through a mirror clear
That hangs before her all the year,
Shadows of the world appear.
There she sees the highway near,
Winding down to Camelot ;
There the river eddy whirls,
And there the surly village churls,
And the red cloaks of market girls,
Pass onward from Shalott.

Sometimes a troop of damsels glad,
An abbot on an ambling pad,
Sometimes a curly shepherd lad,
Or long-haired page in crimson clad,
Goes by to towered Camelot.
And sometimes through the mirror blue
The knights come riding two and two.
She hath no loyal knight and true,
The Lady of Shalott.

24 POINT 15 a \$2 10 10 A 15 a \$4 50

OF CAMELOT
KING ARTHUR

Herein is notification that the king's minister, Hank Morgan, for ancient

COPPERPLATE ROMAN

10 POINT

20 A \$3 00

FINE ART EXHIBIT
MODERN PRINTING

8 POINT

25 A \$2 75

GAXTON SQUARE GUILD
N^{OS} 154-68 QUADRATE ST
TYPANTOWN, VERMONT

TELEPHONE N^o 65-73 W

OWNES & BROS.
COLLECTORS

GENERAL OFFICE

S. A.

FINE GLAZED
LABEL PAPER

HIGH-CLASS FLAT
WRITING PAPERS



WE DO NOT SELL TO PARTIES WITHOUT
GOOD COMMERCIAL STANDING OR WHO
CANNOT FURNISH A N^o 1 REFERENCES

N^o 632 DAWSON AVENUE
ST. MICHAELS, ALASKA

6 POINT No 1

30 A \$1 25

THE FIRST EXPOSITION EVER HELD
DEVOTED ENTIRELY TO PROGRESS
MADE IN THE ART PRESERVATIVE

6 POINT No 2

60 A \$1 75

CONTEMPORARIES WHO DESIRE TO ENTER
THEIR SPECIMENS SHOULD WRITE TO OUR
M^r SECRETARY FOR FULL PARTICULARS

6 POINT No 3

60 A \$1 75

VALUABLE PRIZES WILL BE OFFERED FOR THE
TWENTY-THREE BEST UP-TO-DATE PRODUCTIONS

9 8 8 7 EXECUTIVE BOARD OF TRADE 1 2 3 4

ENGRAVERS
PRINTERS
EMBOSSERS

& COMPANY

N^o 73 MILK ST, DES MOINES, IOWA

YOU ARE CORDIALLY INVITED TO ATTEND
AN INFORMAL MEETING

OF THE

EXECUTIVE BOARD

OF

THE FINE ART PRINTING
EXHIBITION

TO BE HELD AT

CAXTON SQUARE GUILD

(ROOM 6)

TUESDAY EVENING, SEPTEMBER 15TH, 1908

AT 7 O'CLOCK

DELEGATE TO THE
MUNICIPAL

MR.

REPRESENTING
CALIFORNIA

CONDITIONS
OPEN TO ALL

THE EXACT DIMENSIONS
MUST BE 6 X 9 INCHES
NO RESTRICTIONS

TYPE, ORNAMENTS OR BORDERS, EXCEPTING
THAT EVERYTHING MUST BE THE PRODUCT
OF THE LEADING TYPE FOUNDRY IN THE
UNITED STATES. TWENTY-FIVE PROOFS, IN
ONE COLOR OF INK, ON ONE HUNDRED POUND
STOCK, 9 X 12 INCHES IN SIZE, AND MUST BE
MAILED FLAT. ON THE PROOFS, AND ON A
FRANKED ENVELOPE ACCOMPANYING THEM
MUST APPEAR THE NAME OF THE PRINTER

ADDRESS ALL SPECIMENS TO MR. IRA
SOUTH, EDITOR, BETHLEHEM SENTINEL

THE PROMOTERS OF THIS EXHIBITION DESIRE
TO SHOW SPECIMENS OF PRINTING OF
EXCEPTIONAL MERIT

TELEPHONE, 579

ORNTON

COMMITTEE OF ARRANGEMENTS

SAM. COMFORT | W. R. THORNTON
G. H. ROBERTS | CLAY I. MOUNT

NO. 31 HIGH ST., UTICA, N. Y.

CARD MERCANTILE

SOME
OFF-HAND
USES

ROBERT A. BURNHAM

REPRESENTING
BOSTON AUTOMOBILE COMPANY
OFFICE 104 MILK STREET

GEORGE H. REBERS

JOSEPH K. BRONCH

REBERS & BRONCH

MEMBERS NEW YORK AND BOSTON
STOCK EXCHANGES

MORTGAGE
SECURITIES

BONDS

SUBURBAN
PROPERTIES

COLLATERAL LOANS WITHOUT SECURITY TO PERSONS IN
PROSPEROUS CIRCUMSTANCES

ROOMS 35-36 ARLINGTON BUILDINGS

BOSTON, MASS.



GEORGE MORGAN BROWNE

BORN MAY 2, 1899

WEIGHT 8 POUNDS

CARD MERCANTILE

30 POINT No 10

5 A \$3 00

SERIES 10

24 POINT No 9

6 A \$2 75

LONGINGS

18 POINT No 8

8 A \$2 50

MORE TYPES

12 POINT No 7

14 A \$2 00

FINE CLEAN CARD

10 POINT No 6

16 A \$1 75

UNIQUE \$32.58 DESIGNS

8 POINT No 5

18 A \$1 50

AMERICAN TYPE FOUNDERS CO.

6 POINT No 4

20 A \$1 25

CARDS AND HEADINGS ARE INVESTED
WITH FINE ARISTOCRATIC SHARPNESS

6 POINT No 3

20 A \$1 15

AND IT IS DIFFICULT IF NOT IMPOSSIBLE TO
IMAGINE HOW ANYTHING FINER EVER CAN

6 POINT No 2

22 A \$1 00

FOR IMITATING THE WORK OF STEEL ENGRAVERS THERE
CAN BE NOTHING MORE BEAUTIFUL PICKED FROM A CASE

6 POINT No 1

26 A \$1 00

THE CARD MERCANTILE SERIES IS AN ABSOLUTE NECESSITY IN MODERNIZED
COMMUNITIES WHEREIN THE PEOPLE PATRONIZE ONLY 20TH CENTURY PRINTERS

MERCANTILE SERIES

16 POINT

10 A 10 A \$3 00

NICE WORK
 GRAND FACES
 1902

SCRIPT IS NOW SUPERSEDED BY MERCANTILE
 FOR FINE STATIONERY. EVERY
 PRINTER NEEDS IT

JOHN B. HOMER

EASTERN SELLING AGENT

CHILSON SEWING MACHINE

SALESROOM

NUMBER 265 ANDREW SQUARE

MERIDEN, CONN.

14 POINT

12 A 12 A \$2 75

NEAT ON CARDS
 PLEASE MORE

12 POINT

14 A 14 A \$2 50

USEFUL MESSAGE
 MODEST COMPS

MERCANTILE SERIES

11 POINT

16 A 16 A \$2 25

BOARD AND SUPPER
DINNERS BOILED

10 POINT

18 A 18 A \$2 00

SENSIBLE PRINTERY
CLEAR LEGIBLE LETTER
LARGE PROFIT

GEORGE R. MENDUM

No. 265 ANDREW SQUARE
MERIDEN

8 POINT

20 A 20 A \$1 75

ANOTHER GOOD FEATURE
PLENTY FIGURES ACCOMPANY
EACH \$2.85 FONT

6 POINT

30 A 30 A \$2 25

FOR SALE AT ALL THE BRANCHES
AMERICAN TYPE FOUNDERS COMPANY
UNITED STATES AMERICA

GEOMETRIC SERIES

24 POINT

10 A 15 a \$5 00

PRINT CHROMO
Rent Church House 52

10 POINT

13 A 40 a \$3 50

6 POINT

16 A 50 a \$2 75

LITERARY LONGINGS

Though you may try hard to fill this want, we quite despair of success crowning your efforts, since the yearners find it quite impossible to furnish you with the slightest hint \$2

TYPOGRAPHIC EXHIBIT

Believing that refined taste and elegance in the various productions of the printer give that hold upon public consideration which could not be secured in any other way, we respectfully invite you to contribute to the Exhibition of Letter-Press Printing. You are requested to send one or more specimens of work done at your establishment in furtherance 52

12 POINT

12 A 34 a \$4 00

FINE GERMAN PAINTINGS

Recollections Embellished with Engravings 72
Reduced Price-List

6 POINT NO 2

16 A 16 A 50 a \$3 50

8 POINT

16 A 50 a \$3 50

FORMS FOR ELECTROTYPING

Electrotypers experience a considerable difficulty from forms which have not been properly locked up. A proof from a form, taken after the quoins have been pushed up with the fingers, may show every line straight and no displacement anywhere: afterwards, in finishing the lock-up, a tightening of the quoins with the mallet or the wrench will cause a derangement of lines and type at once unsafe and provoking. In the course of another 54

EDUCATED COMPOSITOR

The Printer is an indispensable adjunct of civilization and progress; and in the United States from the ranks of the army of printers have rose more brilliant men in literature and a greater number of statesmen, than have risen from the ranks 25

18 POINT

10 A 24 a \$4 50

DRAMA PRODUCTION

Book Catalogue of Sermons \$35

GEOMETRIC ITALIC

24 POINT

10 A 15 a \$5 00

*HISTORIES STATED
Ramble During Vacation \$6*

10 POINT

13 A 40 a \$3 50

SUCCESSFUL FOREMEN

A man to be an entire success as a foreman, must make up his mind to be virtually a student for life, and use every means in his power to acquire knowledge. Education of his heart should never be sacrificed to that 48

6 POINT

16 A 50 a \$2 75

WRITERS FOR THE PRESS

An English writer says that one may be desultory over one's dinner to some good purpose, or even in the enjoyment of a holiday, but in writing for one's daily bread, never. In the infantine stage of my apprenticeship I would never move towards the ink-pot unless I were impelled by a very vigorous inspiration, such as resulted in my tragedy or my first novel, and I would then write on and on, with utter disregard of the 76

12 POINT

12 A 34 a \$4 00

DRAWINGS CHEERFULLY FURNISHED

*Seventeen Benevolent Gentlemen Contemplated \$124
Building Durable Institutions*

6 POINT NO 2

16 A 16 A 50 a \$3 50

TASTE DISPLAYED IN PRINTING

Printers have good reason to congratulate themselves on the progress of art in their work, because the artistic portion of their labors circulates among the great mass of the people by whom these specimens are appreciated, studied and well preserved. In the past fifteen years the best original talent existing among our printers has been devoted to job work, and with the happiest effects. The pioneers in this departure made abundant work of the same \$250

8 POINT

16 A 50 a \$3 50

PRINTING-OFFICE GRADUATES

Among journalists many have received their earlier training at the printer's case. This does not by any means prove that to become an accomplished editor it is necessary to become an accomplished printer. A great proportion of the printers could never write the articles they put in type, and many 83

18 POINT

10 A 24 a \$4 50

MUSICAL COMÉDY COMPANY

Extraordinary American Engagement 27

CUSHING SERIES

24 POINT

10 A 15 a \$4 50

BRIGHT CUSHING TYPES
REACH UNIVERSAL USE.
First conception had no other
intention than to provide letter
for book work adapted for pro-
ducing clear and durable plate

18 POINT

12 A 18 a \$4 00

COMBINING THESE FEATURES
WITH THE DEPARTURE WHICH
It represented in roman faces, quickly
attracted attention of shrewd publisher
and printer as highly serviceable letter

15 POINT

15 A 25 a \$3 50

THREE LARGER SIZES SHOWN HEREIN
BEING RECENT ADDITIONS TO SERIES
Making seven nicely graded sizes and extend-
ing its usefulness into the illimitable domain of
general display work, permanently established
in the typography of the christian and barbarian

Cushing Italic shown on pages 155, 260 and 261

CUSHING SERIES

12 POINT

14 A 8 A 36 a \$5 00

WHEN THE BROWN LEAVES WHIRL AND SCAMPER
AROUND THE COLDEST CORNER OF THE VILLAGE

Bare branches creak and complain in the shivering blasts, then suggestions of warmth and comfort do not come amiss. Each year it is the same but the longing for the comfortable big chair over the furnace register grows apace and warming out-doors

12345

BECOMES SOMEWHAT UNSATISFACTORY

67890

8 POINT

20 A 12 A 44 a \$4 00

CONTENTS OF AN ENVELOPE FOUND ON
EAST BEACH AND THE CONSEQUENCES
WHICH BEFEL THE ROMANTIC MAIDEN

HER eyes spied the photograph of a young man not much older than herself, but with an earnest face; the head was well shaped, the mouth firm and expressive and the eyes deepset and serious looking. Placing the picture on her desk she turned to her book, but there was a fascination about the picture which drew her eyes toward it frequently, when she would be met with those eyes that seemed to look at her reproachfully yet kindly. For the first time she found her book distasteful; it appeared silly, and she threw it down and sat gazing abstractedly at the picture before her. It seemed to her the expression of an earnest spirit and brought home to her careless

MIND THE UTTER NONSENSE OF EXISTENCE

6 POINT

20 A 12 A 50 a \$3 50

CIDER-MAKING TIME

THEY are gathering the apples
In the orchard on the hill,
They are carrying the baskets
To the humming cider mill;
The breeze is blowing sweetly
And the autumn days are fair,
The happy farmer whistles
As he works away, out there.

And the smoke is curling upward
As it used to, long ago,
When the winds that made our noses
Rather moist began to blow.
Down the crumpled leaves are falling
From the branches overhead,
And the doves are softly cooing
On the weather-beaten shed;

The ground is strewn with pumpkins
Where the corn is cut away,
And the slopes beyond the valley
Lie in something soft and gray,
While a sort of dreamy music

10 POINT

16 A 10 A 40 a \$4 50

CERTAIN METHOD OF OBTAINING OTHER PEOPLE'S MONEY IS
TO HAVE SOMETHING THEY WANT AND TO LET THEM KNOW

You have it, where they can secure it and what is the basis of exchange. These facts told simply, plainly and honestly by advertisements correctly written and judiciously displayed in the right mediums, will as surely bring you money in exchange for your goods as the day succeeds the night, the relative proportions of your giving and receiving depending naturally upon the value of your goods

12345

THE DRAWING POWER OF YOUR STATEMENT

67890

RAMONA SERIES

30 POINT

6 A 14 a \$4 75

The Clothing Exhibition has been re-opened at this Store, and will be Pleased to have you call

24 POINT

8 A 20 a \$4 60

Stylish Chesterfield Spring Overcoats
Decidedly English and Fashionable \$58

YOU are cordially invited to attend the
Entertainment given by the

Children of the Kindergarten
Fourth Section



At 7 o'clock

Easter Monday

18 POINT

10 A 32 a \$4 50

Opening Day in our Millinery Department

Surprises in Winter Headgear from Parisian Fashions await your Critical Inspection. Trimmings of unusual fineness are on our counters ready for the Opening-Day Crowds to Examine.

Witherspoon, Philander & Company

HERMES SERIES

36 POINT

6 A 10 a \$5 50

DECLINE OF OLD ROME

Palace of the Senators in Ruins

24 POINT

10 A 15 a \$4 50

HIGH ADMISSION TICKETS

Scathing Denunciations Really Deserved

18 POINT

12 A 18 a \$3 25

DIABOLICAL PLOT

Exposed by Mere Accident

12 POINT

18 A 24 a \$3 00

SURGICAL OPERATIONS

Performed With Neatness 74 Dispatch

SIGNET SERIES

9 POINT

12 A 24 a \$2 10

I love to look on these young
faces, and see the firstlings of
the young Man's beard, and 23

18 POINT

8 A 16 a \$3 85

Every day sends to their
graves a number of the

36 POINT

4 A 8 a \$6 60

Dry Goods and Furnishings

24 POINT

6 A 12 A \$4 40

Let honesty be the
breath of each Soul,

12 POINT

10 A 20 a \$2 70

Our several Departments
are fully stocked with fine
Merchandising, match 45

JUPITER SERIES

48 POINT

4 A 6 a \$7 00

ALL YEAR
Have Gun Sport 25

36 POINT

6 A 9 a \$5 75

LUMBER REGION
Boy • Wandering • Home • 74

24 POINT

8 A 12 a \$4 50

ANNUAL • PARADE
Stylish Garment Made to Order \$3

18 POINT

12 A 16 a \$3 50

QUARTERLY PAYMENT
Choice Viands Served from Chinaware 674

12 POINT

16 A 26 a \$3 00

BUY DEWDROPS

Show • Election • Returns • \$45

10 POINT

16 A 40 a \$3 00

BELLS OF SHANDON

Ringing Chiming Melodiously \$435

WEBSTER SERIES

36 POINT

3 A 6 a \$5 00

ENGINEERING
Mechanical Lessons

24 POINT

6 A 10 a \$4 00

GRAND BANQUET
Visiting European Statesmen

18 POINT

8 A 14 a \$3 25

BUILDER AND MECHANIC
Constructors of Famous Modern Dwellings
Satisfaction Guaranteed

12 POINT

12 A 22 a \$3 00

WONDERFUL ELECTRIC MACHINERY
Examinations by the General Public Particularly Desired
Exhibition at Manufactory

10 POINT

16 A 22 a \$2 75

BEAUTIFUL HOLIDAY PRESENTS OFFERED
Customers are Respectfully Requested to Examine these Articles

1234567890

UNIQUE CELTIC

36 POINT

4 A 6 a \$6 20

Famous SIGNS

30 POINT

6 A 8 a \$5 35

BREAD Producers

24 POINT

7 A 10 a \$4 05

Inconsistent REMARKS

18 POINT

10 A 14 a \$3 60

Railroad FREIGHT Contracts

14 POINT

12 A 18 a \$3 25

SUBLIME SHOWING
Annual Parisian Trimming Display

12 POINT

15 A 22 a \$3 00

UNBIASED
Decision Rendered

10 POINT

18 A 28 a \$2 90

SEMPER IDEM
Sunshine after Storm

8 POINT

20 A 32 a \$2 60

CONNOISSEURS
Spacious Pothouse Patrons
12345678

6 POINT

22 A 35 a \$2 50

MINERAL DEPOSITS
Auriferous Dumping Grounds
1234567890

UNIQUE CELTIC CONDENSED

36 POINT

4 A 6 a \$4 25

Enthusiastic HORDES

30 POINT

6 A 8 a \$3 75

SPORTIVE Demonstration

24 POINT

8 A 10 a \$3 25

WINSOME VIRGINS
Humorist Banishing Melancholy

18 POINT

12 A 16 a \$3 00

ORATORICAL REFORMERS
Smockfrocked Blatherskites Gesticulating

12 POINT

18 A 30 a \$2 75

DARING SEARCH
Returned Seamen Rejoicing
after a Perilous Expedition

8 POINT

25 A 38 a \$2 25

MACHINES PERFECTED
Labor-Saving Apparatus Guaranteed
Complete with all the Latest Devices
1 2 3 4 5 6 7 8 9 0

10 POINT

20 A 34 a \$2 50

FOREIGN VIEWS
Memorable Scenes Reproduced
by the New Electric Verascope

6 POINT

30 A 45 a \$2 00

EXPEDITION TO WONDERLAND
Language Fails to Describe this Wonderful Isle
which is Situated in the North Atlantic Ocean
1 2 3 4 5 6 7 8 9 0

CELTIC No 3 SERIES

24 POINT

8 A 8 A 10a \$6 70

PROMINENCE
Great Natural Lakes
RUSTIC HOMES

18 POINT

10 A 10 A 15a \$5 45

SUMMER TOURIST
Reliable Pacific Steamer
PLEASURE TRIPS

12 POINT

14 A 14 A 20a \$4 30

SOUTHERN EXPOSITION
Grand Cotton Plantation Exhibits
INDUSTRIAL RESOURCES

10 POINT

18 A 18 A 30a \$4 10

RICH COSTUME
Dramatical Combine
GRAND OPERA

8 POINT

20 A 20 A 40a \$3 85

HOME PRODUCT
American Iron Dealers
MINING REGIONS

7 POINT

20 A 20 A 40a \$3 00

LONDON INSURANCE
All Losses and Damages Paid
123 RELIABLE 678

6 POINT

35 A 30 A 40a \$3 90

LATEST IMPROVED MACHINE
Patented Brass Rule Mitring Machine
12345 ORNAMENTS 67890

ROMANESQUE SERIES

30 POINT NO 150

5 A 5 A \$5 10

CLEVER GENIUS

24 POINT NO 150

6 A 6 A \$4 00

TIN CANS

18 POINT NO 150

10 A 10 A \$3 50

SPAN INSIDE

12 POINT NO 150

14 A 14 A \$3 00

ALMOST PRECISE

10 POINT NO 150

16 A 16 A \$2 50

HARBOR IN AUTUMN

8 POINT NO 150

18 A 18 A \$2 00

FASTENED OLD SPRING

6 POINT NO 151

20 A 20 A \$2 25

PEDESTRIAN TAKEN PRISONER

6 POINT NO 152

20 A 20 A \$2 25

RESERVED MEN OF STRONG CHARACTER

1 2 3 4 5 6 7 8 9 0

6 POINT NO 153

20 A 20 A \$2 25

DULL CHRISTMAS SPORTS WITHOUT FROST AND SNOW

1 2 3 4 5 6 7 8 9 0

NORMAN CONDENSED

36 POINT

5 A 6 A \$4 50

SEASIDE PROMENADE

24 POINT

5 A 8 A \$3 83

HUNTER
MEAN BEARS

18 POINT

10 A 16 A \$3 15

PHANTOMS
GHOST APPARITIONS

12 POINT

20 A 32 A \$2 95

OFFICIAL BUSINESS
MUNICIPAL INDEBTEDNESS

1 2 3 4 5 6 7 8 9 0

10 POINT

20 A 32 A \$2 93

CHRISTMAS THOUGHTS
FAIR WONDERLAND PANORAMA

1 2 3 4 5 6 7 8 9 0

GUTENBERG SERIES

24 POINT

5 A 10 a \$3 60

Commendable · Principles · and · Practices
 Promptness in Settling Accounts 368

18 POINT

6 A 14 a \$3 20

Distracted · Proprietors · and · Exasperated · Patrons
 Initiating an Awkward Squad of Youths into the
 Art and Mysteries of the Printing Business 1429

12 POINT

8 A 20 a \$2 45

The · Commonwealth · Finance · Company · of · Squanderquick, · Kentucky
 Provides Methods to Speedily Reduce the Weight of Pocket-Books,
 Makes Openings for Dropping Hard Earnings into Saloon Mills 57

GRIMALDI SERIES

24 POINT

7 A 14 a \$4 50

☉ HANDSOME EMBROIDERIES ☉
 Lace curtains are coming out of closet
 and chest for the fall season fixing 1387

18 POINT

8 A 16 a \$3 50

⊕ ANTIQUE FURNITURE REMODELLED ⊕
 Reupholstering is an important and large part of our
 business and this is a good time to send for us. 7892

Ornaments with each size

LIGHT-FACE No 158

30 POINT

7 A 8 a \$5 00

INTERESTING
Guaranteed Securities

24 POINT

8 A 12 a \$4 50

GREAT BORES
Tunnels through Hoosac

20 POINT

12 A 16 a \$4 00

SLEIGH RIDING
Invigorating and Exhilarating

18 POINT

15 A 20 a \$3 50

GENEROUS PEOPLE
Distributing Charity Unsparingly

12 POINT

20 A 30 a \$3 25

ROUGH-SHOD
Jumping over Streams

10 POINT

24 A 32 a \$3 00

COMPLIMENTARY
Third Annual Excursion

8 POINT

24 A 36 a \$2 75

PARENTAL PHYSIC
Spring Woodshed Exercises
1234567890

6 POINT

30 A 40 a \$2 50

MODERN LEGISLATION
Protecting Corporation Monopolies
1234567890

MUNICH SERIES

48 POINT

3 A 5 a \$6 50

MODERN Character

36 POINT

4 A 6 a \$5 00

Unique Gentle MULCOHY

24 POINT

7 A 10 a \$4 00

GATHER BEAR Aboard the Boat

18 POINT

10 A 15 a \$3 25

Recreation and Fun at THE SOCIAL HOP 1902

DRESDEN SERIES

48 POINT

4 A 7 a \$5 50

MEN SMOKE and Boys Ditto

36 POINT

6 A 9 a \$4 50

Barbers Advertise QUIET SHAVERS

24 POINT

8 A 12 a \$4 00

LIKE THE WOMAN Who Danced Unknown

18 POINT

12 A 18 a \$3 25

Just Four Cans of Milk WILL ANSWER KITZY \$12,894

MERCANTILE BOLD

48 POINT

4 A \$5 00

CHICAGO

36 POINT

5 A \$4 00

HOME LINES
FOR 1902

24 POINT

6 A \$3 00

RUSHED ALONG
WESTERN

20 POINT

7 A \$2 75

UNIQUE FOR JOBBER
USEFUL TYPES

18 POINT

8 A \$2 50

UNITED STATES AMERICA
BRANCH STORE

ALPINE SERIES

36 POINT

4 A 8a \$5 80

Southern Light Movements

24 POINT

6 A 12a \$4 35

Honesty Eliminated Through Perversity
Governing Universal Educational Course

18 POINT

8 A 16a \$3 65

Enthusiastic Conventions
Bostonian 53 Institutions

12 POINT

10 A 20a \$2 35

Millionaires Charitable Association
Established in 1874 San Francisco
Graduated Nurses in the Hospitals

HANSARD SERIES

24 POINT

7 A 12a \$4 45

SOUND LOGIC
Destroyed Argument

18 POINT

9 A 14a \$3 75

FARMS
Reductions

12 POINT

14 A 22a \$2 90

REGISTER
House Warmers

9 POINT

16 A 25a \$2 50

INSTRUCTOR
Scientific Rambling
12345678

6 POINT

18 A 30a \$2 10

MAKING FRIENDS
New Methods of Oscitation
1234567890

OUTING SERIES

A

12 POINT NO 46

14 A \$2 00

ARTISTIC MECHANICAL ENGRAVING
BEST AND CREAPEST

12 POINT NO 47

16 A \$1 75

CONSTANT SEARCHERS BEST REWARDED
KNOWLEDGE OBTAINABLE

12 POINT NO 48

18 A \$1 75

ANNUAL WATER CARNIVAL NEAR NANTASKET BEACH
WOMEN AND CHILDREN INVITED

6 POINT NO 42

20 A \$1 75

MOUNTAIN TOURISTS RETURN
EXPERIENCE HARDSHIP

6 POINT NO 43

30 A \$1 75

OPENING OF SPRING MILLINERY GOODS
NEW TRIMMINGS AND FEATHERS

6 POINT NO 44

40 A \$1 50

FRESH PUBLICATIONS CIRCULATED
SEVERAL HISTORIC PERSONS ARE MENTIONED
1 2 3 4 5 6 7 8 9

6 POINT NO 45

40 A \$1 50

FRESH IMPORTATIONS ARRIVING DAILY
COMMODIOUS QUARTERS FOR INCREASING PATRONAGE
1 2 3 4 5 6 7 8 9 0

MORNING GLORY

F

36 POINT

7 A 12 a \$5 00

Universal Protective Association Disbands
UNDESIRABLE BROTHERS

24 POINT

12 A 20 a \$4 00

We heartily extend to you a
special invitation to visit our
GREAT EMPORIUM 418

18 POINT

12 A 32 a \$3 25

The finest line of Novelties are here
for your inspection and you are sure
to be pleased with our grand display
SUPERIOR ARTICLES \$9,267.50

HARPER SERIES

48 POINT

4 A 4 A 9a \$11 00

Patriotic :: Declarations
 • Eastern • Glass • Exhibit •

36 POINT

4 A 5 A 10a \$7 75

Water • Remarkable • Rains
 Buyers' Annual Catalogues 3

24 POINT

4 A 8 A 18a \$6 50

• Honorable :: Charitable :: Associations •
 Giving Swell Foreign Reception
 Steamboat • or • Railroad • Lines \$150

18 POINT

4 A 8 A 18a \$4 75

Darling Little Maiden
 * Auburn • Locks *
 :: Magnificent Scripts ::

12 POINT

8 A 12 A 26a \$4 00

Many Entertaining Narratives
 • Arabian * Amusement •
 Thousand Fairy Romances 54

CENTURY SERIES

36 POINT

4 A 6 a \$5 00

ALGOUND & MOUNGER ©

≡ Trade Prices ≡

18 POINT

9 A 14 a \$3 25

KEEPING perhaps the most extensive and freshest stock of any dealer in our line, it is possible for us to quote prices to large retail dealers much lower than can be had elsewhere. During the coming Spring, and until notified otherwise, the discount will be

24 POINT

6 A 9 a \$4 00

Ten per cent, 6 months
Fifteen for spot

And we trust that your liberal orders of the past will be continued in future

ALGOUND & MOUNGER

RUNIC CONDENSED No 122

60 POINT

4 A \$6 55

RESORTS

48 POINT

4 A \$4 05

FAITH CURE

42 POINT

6 A \$4 05

ASTRONOMICAL

36 POINT

8 A \$3 15

MINERAL DEPOSITS

24 POINT

10 A \$2 40

ORNAMENT

20 POINT

12 A \$2 10

CELEBRATION

16 POINT

16 A \$1 75

EVENING GOWNS

12 POINT

18 A \$1 35

NEVER EXPECT MUCH

10 POINT

24 A \$1 30

CALIFORNIA TALL FORESTS
1234567890

8 POINT

32 A \$1 40

BROUGHT SUFFICIENT REWARDS
1234567890

RUNIC CONDENSED No 120

72 POINT

3 A 5 a \$12 85

DOG Hunt

60 POINT

3 A 5 a \$8 25

Roman GOLD

48 POINT

3 A 6 a \$6 10

UNITED Soldiers

42 POINT

4 A 8 a \$4 60

Builders STEAMSHIP

30 POINT

5 A 10 a \$3 40

HIGH Grade

24 POINT

6 A 12 a \$2 80

LUMBER Yard

18 POINT

8 A 16 a \$2 60

GOLD STANDARD
United Americans

14 POINT

10 A 20 a \$2 05

SUBMARINE TORPEDO
Long Distance Runners

12 POINT

12 A 24 a \$1 80

MACHINERY IMPROVEMENT
Independence Declarations
1234567890

10 POINT

18 A 36 a \$1 95

CONGRESSIONAL COMMITTEEMEN
Twelfth and Seventeenth Districts
1234567890

LIGHT RUNIC SERIES

60 POINT NO 110

4 A 6 a \$9 35

TIME Records

42 POINT NO 152

5 A 8 a \$7 25

Mansion HOUSE

36 POINT NO 110

5 A 8 a \$6 85

RUINED Landlord

30 POINT NO 152

8 A 12 a \$5 95

Magnificent LOUNGES

24 POINT NO 152

10 A 16 a \$4 55

INDUSTRIAL Organizations

18 POINT NO 152

12 A 18 a \$3 30

MEETINGS
Religious Service

14 POINT NO 152

14 A 20 a \$2 40

ENTERPRISING
Business Undertakings

12 POINT NO 152

20 A 40 a \$2 80

NATIONS CONSULTING
Peace With the United States
1234567890

10 POINT NO 152

18 A 36 a \$2 00

POLITICAL CONVENTION
Discussing Good Solid Government
1234567890

LIGHTFACE CELTIC No 150

48 POINT

3 A 4 a \$8 50

THE Pink

36 POINT

4 A 6 a \$6 25

Hound NETS

30 POINT

5 A 7 a \$5 00

LENDs Machines

24 POINT

7 A 10 a \$3 50

ENTERPRISE
Making Ocean Breezes

18 POINT

10 A 16 a \$3 25

RECONSTRUCTION
Fuglemen Swearing Allegiance

12 POINT

16 A 26 a \$3 00

AGONIZING
Felines Nightly Song

8 POINT

20 A 30 a \$2 50

MODERN KNIGHTS
Heart of Tender Sensibility
1234567890

10 POINT

18 A 28 a \$2 75

INDIFFERENCE
Unconcerned Spectators

6 POINT

22 A 32 a \$2 25

EUREKA RESTAURANT
Gutta Percha Beef and Ram Chops
1234567890

BOLDFACE CELTIC

42 POINT

4 A 6 a \$7 50

COLD Pearl

36 POINT

4 A 6 a \$5 55

Board TESTED

30 POINT

6 A 10 a \$5 40

HUNTING Malster

24 POINT

8 A 12 a \$4 40

SENATE RUMORS
Interlocutory Exercises 12

18 POINT

10 A 15 a \$3 35

NEAR FLOWER BEDS
Scotch Horticultural Institutes 5

12 POINT

15 A 25 a \$3 30

PLEASING
Charming Report

10 POINT

25 A 40 a \$3 95

MOST JOYFUL
Manner and Custom

8 POINT

30 A 50 a \$3 35

GASTRONOMERS
New Luxurious Festivity
32 Entertained

6 POINT

30 A 50 a \$2 90

ANCIENT FOUNDERS
The Pyramids Doting with Age
Mighty Forts 34

PART VIII.

Two-Color

AND

Contour Type Styles

*Several of the Series shown in this Part are designed to work
in colors with the companion series shown elsewhere.*

See reference lines at foot of pages

TWO-COLOR TYPE STYLES

60 POINT BINNER AND BINNER OPEN

EACH 4 A 5 a \$12 25

Matches

For other sizes, see pages 273-275 and 455

48 POINT COLUMBUS NO 2 AND COLUMBUS OUTLINE

EACH 3 A 5 a \$9 35

Mountain

For other sizes, see pages 306, 307, 460 and 461

48 POINT BRADLEY AND BRADLEY OUTLINE

EACH 3 A 8 a \$6 75

Robust Master

For other sizes, see pages 284, 285 and 456

60 POINT LIVERMORE AND LIVERMORE OUTLINE

EACH 3 A 4 a \$8 25

Housewives

For other sizes, see pages 251 and 459

TWO-COLOR TYPE STYLES

60 POINT SATANICK AND SATANICK OPEN

EACH 4 A 5 a \$12 25

Bark Sold

For other sizes, see pages 286-288 and 458

48 POINT BRADLEY ITALIC AND BRADLEY ITALIC OUTLINE

EACH 3 A 7 a \$7 25

Rented House

For other sizes, see pages 240, 241 and 457

60 POINT VIRILE AND VIRILE OPEN

EACH 4 A 6 a \$7 50

Consideration

For other sizes, see pages 358 and 405

60 POINT EREBUS (SOLID) AND HADES (OUTLINE)

EACH 4 A \$5 75

ELEVATORS

For other sizes, see pages 363 and 409

TWO-COLOR TYPE STYLES

48 POINT DEVINNE AND DEVINNE SHADED

EACH 4 A 5 a \$7 75

Rare Mine

For other sizes, see pages 330, 331 and 471

36 POINT MULTIFORM NO 1 AND MULTIFORM NO 2

EACH 4 A \$4 25

ENHANCED

For other sizes, see page 470

36 POINT MULTIFORM NO 1 AND MULTIFORM NO 3

EACH 4 A \$4 25

NOVELTIES

For other sizes, see page 470

48 POINT DEVINNE ITALIC AND DEVINNE ITALIC OUTLINE

EACH 4 A 5 a \$7 75

Bold King

For other sizes, see pages 244, 245, 462 and 463

36 POINT MULTIFORM NO 1 AND MULTIFORM NO 4

EACH 4 A \$4 25

PURCHASE

For other sizes, see page 470

BINNER OPEN

72 POINT

4 A 5 a \$17 00

Per SON

60 POINT

4 A 5 a \$12 25

BEN Hume

48 POINT

4 A 5 a \$7 75

Canary BIRDS

36 POINT

5 A 8 a \$5 50

SINGLE Harness

24 POINT

8 A 10 a \$4 50

Morro Castle DISFIGURED

18 POINT

10 A 16 a \$4 00

HUMOROUS
Clown's Answer
1 2 3 4 5

12 POINT

16 A 20 a \$3 25

MARCH FOURTH
President United Sons
Veterans and Fighters
6 7 8 9 0 \$

Binner, registering with this series, is shown on pages 273-275. See page 452 for specimen in two colors

BRADLEY OUTLINE

60 POINT

3 A 5 a \$8 50

Leads the Style

48 POINT

3 A 8 a \$6 75

Early printers were

36 POINT

4 A 10 a \$5 00

Gothic went out of fashion
in Europe towards the end

24 POINT

5 A 16 a \$3 50

German Printers of 1450 used bold
Black Letters to avoid being detected

18 POINT

8 A 25 a \$3 25

Pages of early books were either large or small
folios, but sometimes quartos, and were there-
fore cumbrous and unhandy ~ Aldus Manuccio

1 2 3 4 5 6 7 8 9 0

Bradley, registering with this series, is shown on pages 284 and 285

See page 452 for specimen in two colors

BRADLEY ITALIC OUTLINE

60 POINT

3 A 5 a \$9 00

Sound Banker

48 POINT

3 A 7 a \$7 25

Novel Time Clock

36 POINT

4 A 10 a \$5 50

Monthly Reports Given

30 POINT

5 A 12 a \$5 00

Quakers Welcome Visitors
Unique Patriotic Ceremony

24 POINT

6 A 18 a \$4 50

Fame and fortune never overtake
men in the day of their discontent

18 POINT

9 A 26 a \$4 00

The perilous rush of Speculators and the
Adventuresome Miner to the Gold Fields

1 2 3 4 5 6 7 8 9 0

Bradley Italic, registering with this series, is shown on pages 240 and 241

See page 453 for specimen in two colors

SATANICK OPEN

72 POINT

4 A 5 a \$17 00

Satanick 8

60 POINT

4 A 5 a \$12 25

Land 3 Mark

54 POINT

4 A 5 a \$10 25

6 Dead Soldier

48 POINT

4 A 5 a \$7 75

friends 7 Grave

36 POINT

5 A 8 a \$5 50

Cunard & Stuart \$2

24 POINT

6 A 15 a \$4 50

Patriotism 

18 POINT

8 A 25 a \$4 00

Railway 58 Coach

Satanick, registering with this series, is shown on pages 286-288. See page 453 for specimen in two colors

LIVERMORE OUTLINE

PATENTED

60 POINT

3 A 4 a \$8 25

Denouncement

48 POINT

3 A 6 a \$6 25

Famous Workmen

36 POINT

4 A 10 a \$5 25

*Remunerated
Determined Advertiser*

30 POINT

5 A 12 a \$4 75

*Generous Patrons
Reward Honest Merchants*

24 POINT

6 A 18 a \$4 25

*Meritorious Investigation
Scientific Explorations Postponed
1 2 3 4 5 6 7 8 9 0*

COLUMBUS OUTLINE

PATENTED

60 POINT

3 A 4 a \$12 35

Rendered
SONG

36 POINT WITH 60 POINT INITIALS

RAISE Vines

48 POINT

3 A 5 a \$9 35

CREAM
Fascination

Columbus No. 2, registering with this series, is shown on pages 306 and 307

See page 452 for specimen in two colors

COLUMBUS OUTLINE

PATENTED

36 POINT

5 A 8 a \$8 00

Recreation
GAME

24 POINT WITH 48 POINT INITIALS

COLD Winds

24 POINT

10 A 15 a \$7 05

VISITOR
Modest Homes

18 POINT WITH 36 POINT INITIALS

Quaint SCENE

18 POINT

15 A 20 a \$6 10

ANIMATED
Fervent Comedian
1 2 3 4 5 6

Columbus No. 2, registering with this series, is shown on pages 306 and 307
See page 452 for specimen in two colors

Columbus Outline
Initials

36 POINT \$2 00
48 POINT 3 00
60 POINT 4 00

B
C
E
F
K
L
Q
R
S
T
V
W

FONTS CONTAIN THE ABOVE
CAPITALS ONLY

DE VINNÈ ITALIC OUTLINE

PATENTED

72 POINT

4 A 5 a \$17 00

Red *INK*

60 POINT

4 A 5 a \$12 25

HER *Pets*

54 POINT

4 A 5 a \$10 25

Little *BOY*

48 POINT

4 A 5 a \$7 75

DIRE *Senate*

42 POINT

4 A 6 a \$7 25

RELIABLE
Hardy *Planter*

DE VINNE ITALIC OUTLINE

PATENTED

36 POINT

5 A 8 a \$6 50

SPECIMEN

Printers Journal

30 POINT

6 A 9 a \$5 75

DEMONSTRATE

Handsome Furnisher
Conclusively

24 POINT

8 A 10 a \$4 50

SCARED
Farm Maids

18 POINT

10 A 16 a \$4 00

REPUBLIC
Italic Type Made
Outlined

14 POINT

12 A 18 a \$2 25

AGRICULTURE
Employing Farmer
13579

12 POINT

16 A 20 a \$3 00

CONTRIBUTOR
Receives Remuneration
1234567

ERRATICK OUTLINE

PATENTED

48 POINT

4 A 5 a \$7 50

SUPERB
Style 4 Boats

42 POINT

4 A 6 a \$6 00

Expert SONG 5

30 POINT

6 A 8 a \$5 50

GRAND 2 Bargains

24 POINT

8 A 12 a \$4 00

BARTON
Historians 2

18 POINT

10 A 18 a \$3 50

MEXICANS
Grand 9 Sports

12 POINT

14 A 24 a \$3 00

ACTORS FANCY
Designed 8 Engraved

10 POINT

16 A 32 a \$2 75

ELEGANT ROSES
That Bloom in Spring 12

8 POINT

20 A 32 a \$2 50

MONROE DOCTRINE
Uncle Samuel Laying Plans 7

6 POINT

20 A 40 a \$2 25

BOULEVARDS SPRINKLED
German Band 29 Exquisite Melodies

VIRILE OPEN

PATENTED

60 POINT

4 A 6 a \$7 50

OPENING Season

48 POINT

6 A 8 a \$6 50

Bountiful HARVESTS

36 POINT

6 A 10 a \$6 00

SLAUGHTERED Buffaloes

30 POINT

8 A 12 a \$5 50

Mexican VOLCANIC Eruptions

24 POINT

10 A 16 a \$4 00

BENEVOLENT GATHERINGS
Honorable and Charitable Associations

18 POINT

12 A 20 a \$3 50

STRONG WIND
Natural Flower Odors
1 2 3 4 5 6 7 8

12 POINT

16 A 30 a \$3 00

PLEASING PRODUCTS
Designed for Modern Printers
1 2 3 4 5 6 7 8 9 0

HOWLAND OPEN

42 POINT

6 A 10 a \$6 50

FIGURING FOR PROFITS
Reliable Printing Concern

60 POINT

4 A 5 a \$9 50

GRAND
Masher

12 POINT

20 A 30 a \$3 00

WHEN WORKED IN ONE
COLOR HOWLAND OPEN

Is a handsome letter, but
when the Howland Open
and the Howland are put
one over the other in two
colors the effect is catchy

30 POINT

8 A 12 a \$5 50

DISCHARGE HER MUSICIAN
Charming Melodious Strains

24 POINT

10 A 16 a \$4 50

DESIGNING HANDSOME BROCHURE
Quickly Readable Impression Pages

HOWLAND OPEN

48 POINT

5 A 8 a \$7 50

UNIQUE AND BRIGHT
Reclaimed Bumboats

10 POINT

24 A 36 a \$2 75

SERIES IS COMPLETE IN NINE
HANDY SIZES, WITH FIGURES

And, as in the Howland Series,
the capital O O is made in two
thicknesses, a capital idea for a
capital letter that is frequently
used, as it assists greatly when
it is desirable to fill out a line

54 POINT

4 A 6 a \$8 50

QUINCES
Jelly \$62

18 POINT

12 A 20 a \$3 75

EXTRAORDINARY BARGAINS IN COMFORTABLES
AND DOUBLE BLANKETS FOR CAMPING PARTIES

HOLDING perhaps the largest stock of vacation
supplies in this part of the country, we have
concluded to make an effort to reduce many
of our lines before the season closes. To this end
we have marked all goods to absurd prices \$26.59

QUAINT OPEN

PATENTED

48 POINT

4 A \$4 00

GRAND · JOKER

36 POINT

6 A \$3 40

EVENING · SERMON

24 POINT

8 A \$2 90

THIRD · NATIONAL · BANK

18 POINT

10 A \$2 25

STRONG · AND · HEARTY
HISTORIC · CHESTNUT · SOCIETY

12 POINT

14 A \$1 90

REVIEWING GRAND PARADE
PHILADELPHIA · VETERAN · ASSOCIATION

10 POINT

20 A \$1 90

GOLD · AND · SILVER
RICH DIAMOND FIELDS
· 1 2 3 4 5 6 7 8 ·

8 POINT

24 A \$1 90

HUMFTE · & · DUMFTE
DEALERS AND FURNISHERS
· 1 2 3 4 5 6 7 8 9 0 ·

EPITAPH OPEN

48 POINT

3 A \$6 00

MACHINERY

36 POINT

5 A \$4 25

BOY LOANS GUN

24 POINT

7 A \$3 25

HUNTS LEGAL NOTICE

Epitaph, registering with this series, is shown on page 362

HADES SERIES

60 POINT

4 A \$5 75

MANY COLORS

48 POINT

5 A \$4 50

HANDSOME FACE

36 POINT

6 A \$3 50

MOUNTING

24 POINT

8 A \$2 25

ROMANESQUE 4

Erebus, registering with this series, is shown on page 363. See page 453 for specimen in two colors

MULTIFORM No 1

36 POINT 4 A \$4 25

DRAIN

30 POINT 5 A \$3 75

BINDER

24 POINT 6 A \$3 25

WINTERS

18 POINT 8 A \$2 75

BOND * SOLD
123456

MULTIFORM No 2

36 POINT 4 A \$4 25

DRAIN

30 POINT 5 A \$3 75

BINDER

24 POINT 6 A \$3 25

WINTERS

18 POINT 8 A \$2 75

BOND * SOLD
123456

MULTIFORM No 3

36 POINT 4 A \$4 25

DRAIN

30 POINT 5 A \$3 75

BINDER

24 POINT 6 A \$3 25

WINTERS

18 POINT 8 A \$2 75

BOND * SOLD
123456

MULTIFORM No 4

36 POINT 4 A \$4 25

DRAIN

30 POINT 5 A \$3 75

BINDER

24 POINT 6 A \$3 25

WINTERS

18 POINT 8 A \$2 75

BOND * SOLD
123456

The Multiform Series make a fine effect when one is printed over the other in different tints. See page 454

DE VINNE SHADED

72 POINT

4 A 5 a \$17 00

HIS Dish

60 POINT

4 A 5 a \$12 50

Dead MET

54 POINT

4 A 5 a \$10 50

BIRD Catch

48 POINT

4 A 5 a \$7 75

Steak RANK

42 POINT

4 A 6 a \$7 50

TRIED Articles

36 POINT

5 A 8 a \$5 75

Lad HIT

24 POINT

8 A 10 a \$4 50

HARD Earth

18 POINT

10 A 16 a \$3 75

ACTOR Pleasing
1 2 3 4 5 6 7 8

12 POINT

16 A 20 a \$3 25

Triumphant CHARMER
1 2 3 4 5 6 7 8 9 0

CONTOUR No 1

48 POINT

4 A 8 a \$8 80

Black HORSE

36 POINT

5 A 10 a \$6 90

UNITED Service

30 POINT

6 A 12 a \$5 15

Carmine BRUSHES

24 POINT

8 A 16 a \$5 00

SURGICAL Operations

20 POINT

10 A 20 a \$5 00

CONSERVATORIES
Musical Question Debated

18 POINT

10 A 20 a \$3 45

ENGAGED
Choice Resort
1 2 3 4 5 6

12 POINT

16 A 32 a \$3 25

CONSIDERED
National Movement
1 2 3 4 5 6 7

CONTOUR No 6

72 POINT

3 A \$5 40

ENUMERATES

60 POINT

3 A \$3 75

BOND 45 MARK

48 POINT

4 A \$3 20

MODERN HEROES

42 POINT

5 A \$2 70

FAMOUS 68 GARDEN

36 POINT

8 A \$2 75

BEAUTIFUL

24 POINT

12 A \$2 25

ADVANCEMENT

18 POINT

18 A \$2 10

BROKERS REPORTS
RECEIVED 49

12 POINT

32 A \$2 00

PERFORMERS BANQUETED
875 GORGEOUSLY

CONTOUR No 7

72 POINT

3 A 6 a \$7 85

Botanical RECORD

60 POINT

3 A 6 a \$5 90

COURSES Maintained

48 POINT

4 A 8 a \$4 40

POSITION SECURED
National Finance Reporter

36 POINT

5 A 10 a \$3 35

POPULAR MOVEMENT
Calisthenic Societies Organized
1 2 3 4 5 6 7 8 9 0

CONTOUR No 4

72 POINT

3 A 5 a \$11 95

Hire MIEN

60 POINT

3 A 5 a \$9 45

END Games

48 POINT

4 A 8 a \$8 20

Defend RIGHT

42 POINT

4 A 8 a \$6 00

STORM Damaged

36 POINT

5 A 10 a \$4 90

Prominent FIREMEN

30 POINT

6 A 12 a \$4 00

REPORTER Promenading

1 2 3 4 5 6 7 8 9 0

CONTOUR No 2

48 POINT

3 A \$4 70

MOTIVES

36 POINT

4 A \$3 30

BIRD 8 CLUB

24 POINT

6 A \$1 90

NOTICES
SENT

18 POINT

8 A \$1 65

NUMEROUS
WOMEN

CONTOUR No 3

36 POINT

3 A \$5 75

RINGS

24 POINT

6 A \$4 25

NOT 4 BIG

18 POINT

6 A \$2 25

BRING MORE
PRODUCE

CONTOUR No 5

48 POINT

3 A \$5 40

BEACON

36 POINT

4 A \$4 00

DECORATE

24 POINT

6 A \$2 35

FOREIGN RACES
65 HORSE

GRAPHIC SERIES

30 POINT

3 A \$3 50

MALDEN GRAPES

24 POINT

6 A \$3 00

FRUITS AND CREAM

22 POINT

7 A \$2 50

TWELVE PEOPLE LOST

18 POINT

8 A \$2 25

BOSTONS SUBWAY CALAMITY
1 2 3 4 5 6 7 8 9 0

PALO ALTO

24 POINT

6 A 20 a \$5 50

POPULAR & SENTIMENT

The profit of Advertising chiefly comes in inducing people to buy more than they need. Civilization is indicated by the extent to which a people indulge in various luxuries & \$3.68

18 POINT

8 A 26 a \$5 00

GENERAL DEPARTMENT STORE

We wish to call your attention to our fine stock of China and Glassware, Bohemian Vases and Dresden Wares of every description which we are prepared to offer at the unusually low price of \$123456890

SANTA CRUZ

24 POINT

18 A \$3 75

BENEVOLENT ASSOCIATIONS ORGANIZED
CONSTITUTION ♦ RECONSIDERED

18 POINT

24 A \$3 00

ARTISTIC ♦ DECORATION
EARTHENWARE \$3

12 POINT

30 A \$2 50

CALISTHENIC ♦ AMUSEMENTS
ADVANCEMENT \$687

PART IX.

Old Style and Modern Roman
JOBGING TYPE

Lightface and Two-Line Letter
Boldface Roman

Title and Condensed Title

CASLON OLD STYLE No 71

72 POINT

3 A 3 a \$14 05

SONGS
Patriotic

60 POINT

3 A 4 a \$10 45

SALUTE
Old Glory

48 POINT

4 A 6 a \$8 50

AMERICAN
Liberty reigns
Fourth of July

CASLON OLD STYLE No 71

42 POINT

5 A 10a \$8 35

CONTENTED
 When, in course
 of human events

36 POINT

7 A 4 A 14a \$9 35

NOTED WRITER
 WHEN, in the course
 of human events, it
 becomes needful for

30 POINT

7 A 4 A 14a \$6 95

RESOLUTE SIGNERS
 WHEN, in course of time,
 it becomes necessary for
 one people to break the

CASLON OLD STYLE No 71

24 POINT

10 A 7 A 20a \$7 65

ADVENT OF LIBERTY
 WHEN, in the course of time,
 it becomes necessary for one
 people to dissolve the political
 bands which connected 9567

22 POINT

14 A 10 A 28a \$7 65

DESIRED BY THE PEOPLE
 WHEN, in the course of human
 events, it becomes necessary for
 one people to dissolve the political
 bands which have connected them
 with another, and to assume 408

18 POINT

18 A 14 A 52a \$8 30

LOVING FREEDOM AND HONOR
 WHEN, in the course of human events,
 it becomes necessary for one people to
 dissolve the political bands which have
 connected them with another, and to
 assume, among the powers of the earth,
 the separate and equal station to 2596

CASLON OLD STYLE No 71

14 POINT

18 A 14 A 52 a \$5 25

COLONIAL REPRESENTATIVES IN CONGRESS ADOPTED THE DECLARATION

WHEN, in the course of human events, it becomes necessary for one people to dissolve the political bands which have connected them with another, and to assume, among the powers of the earth, the separate and equal station to which the laws of nature and of nature's God entitle them, a decent respect to the opinions of mankind requires that they should declare the causes which 32564

12 POINT

12 A 6 A 60 a \$4 60

BUILDING THE FOUNDATIONS OF FREEDOM IMPARTIAL PETITIONS SLIGHTED

WHEN, in the course of human events, it becomes necessary for one people to dissolve the political bands which have connected them with another, and to assume, among the powers of the earth, the separate and equal station to which the laws of nature and of nature's God entitle them, a decent respect to the opinions of mankind requires that they should declare the causes which impel them to the separation. We hold these truths to be self-evident, that all men are created equal; that they are endowed by their Creator with certain unalienable rights 9243

11 POINT

14 A 7 A 70 a \$4 60

BIRTH OF A GOVERNMENT UPON REPUBLICAN IDEAS MUNICIPAL LAWS RECOGNIZED

WHEN, in the course of human events, it becomes necessary for one people to dissolve the political bands which have connected them with another, and to assume, among the powers of the earth, the separate and equal station to which the laws of nature and of nature's God entitle them, a decent respect to the opinions of mankind requires that they should declare the causes which impel them to the separation. We hold these truths to be self-evident, that all men are created equal; that they are endowed by their Creator with certain unalienable rights; that among these are life, liberty, and the pursuit of happiness. That, to secure 1234

CASLON OLD STYLE No 71

10 POINT

15 A 8 A 75 a \$4 45

MANY NOTEWORTHY MEN PUT THEIR SIGNATURES TO THE
DECLARATION OF INDEPENDENCE OF AMERICA

WHEN, in the course of human events, it becomes necessary for one people to dissolve the political bands which have connected them with another, and to assume, among the powers of the earth, the separate and equal station to which the laws of nature and of nature's God entitle them, a decent respect to the opinions of mankind requires that they should declare the causes which impel them to the separation. We hold these truths to be self-evident, that all men are created equal; that they are endowed by their Creator with certain unalienable rights; that among these, are life, liberty, and the pursuit of happiness. That 1234567

8 POINT

20 A 12 A 120 a \$5 40

INDEPENDENCE IS A NECESSITY FOR
THE ENJOYMENT OF LIFE

WHEN, in the course of human events, it becomes necessary for one people to dissolve the political bands which have connected them with another, and to assume, among the powers of the earth, the separate and equal station to which the laws of nature and of nature's God entitle them, a decent respect to the opinions of mankind requires that they should declare the causes which impel them to the separation. We hold these truths to be self-evident, that all men are created equal; that they are endowed by their Creator with certain unalienable rights; that among these are life, liberty, and the pursuit of happiness. That, to secure these rights, governments are instituted among men, deriving their just powers from the consent 123456

6 POINT

25 A 15 A 170 a \$6 95

A DECLARATION OF INDEPENDENCE
BY THE AMERICAN PEOPLE

WHEN, in the course of human events, it shall become necessary for one people to dissolve the political bands which have connected them with another, and to assume, among the powers of the earth, the separate and equal station to which the laws of nature and of nature's God entitle them, a decent respect to the opinions of mankind requires that they should declare the causes which impel them to the separation. We hold these truths to be self-evident, that all men are created equal; that they are endowed by their Creator with certain unalienable rights; that among these, are life, liberty, and the pursuit of happiness. That, to secure these rights, governments are instituted among men, deriving their just powers from the consent of the governed; that, whenever any form of government becomes destructive of these ends, it is the right of the people to alter or to abolish it, and to institute a new government, laying its 1234567890

9 POINT

18 A 9 A 90 a \$4 80

CITIZENS OF OUR LAND OF FREEDOM TOOK UP ARMS AGAINST
THE KING'S TYRANNICAL OPPRESSION

WHEN, in the course of human events, it becomes necessary for one people to dissolve the political bands which have connected them with another, and to assume, among the powers of the earth, the separate and equal station to which the laws of nature and of nature's God entitle them, a decent respect to the opinions of mankind requires that they should declare the causes which impel them to the separation. We hold these truths to be self-evident, that all men are created equal; that they are endowed by their Creator with certain unalienable rights; that among these are life, liberty, and the pursuit of happiness. That, to secure these rights, governments are instituted among men, deriving their just powers from the consent of the governed; that whenever 123

RONALDSON SERIES

For sizes and prices, see following pages

PHILADELPHIA
HORSE SHOW

COMPRISING A LIST OF ENTRIES WITH THE
WINNERS OF PRIZES

Cut No. 2057E. \$1.00

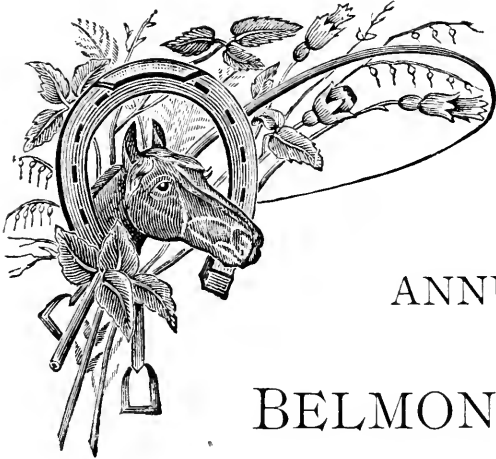

Philadelphia
SEASON OF Horse
1900 Show

ANNUAL EXHIBITION

BY THE

BELMONT DRIVING CLUB

SEASON TICKET, \$10.00

SINGLE ADMISSION, \$1.00

UNDER MANAGEMENT OF

Belmont Driving Club

CANTON PUBLISHING COMPANY
PHILADELPHIA

RONALDSON SERIES

48 POINT OLD STYLE NO 72

5 A 8 a \$8 00

EQUESTRIAN
Rode through the
natural tunnel 76

36 POINT OLD STYLE NO 72

6 A 12 a \$7 00

ROMEO AND IAGO
Dramatic Society was
started by youths 3164

30 POINT OLD STYLE NO 72

8 A 16 a \$5 85

FEMININE ALARMED
Great excitement prevailed
in the village on account of
some idle rumors that 389

RONALDSON SERIES

24 POINT OLD STYLE NO 72

10 A 20 a \$4 70

EXHIBIT AT OUR STORE
 Pessimists say commerce sways
 the world because men are after
 gold; optimists say, because it is
 manifest destiny, and that 2364

18 POINT OLD STYLE NO 72

14 A 30 a \$4 30

STRANGERS WILL BE WELCOME
 This store has as many conveniences as
 the best appointed hotel, with a reception
 room dedicated especially to the comfort
 of strangers in town. It is supplied with
 newspapers, writing facilities, telephones,
 restful chairs and sofas for your use 1289

15 POINT OLD STYLE NO 72

12 A 6 A 40 a \$4 55

SALE OF DOWN QUILTS AND BLANKETS
 This Sale of Fine Bedding has helped many a
 household to liberal economies and splendid Bed
 Coverings. One of the most notable instances
 of value giving is this selling of one thousand
 Down Quilts from our own factories. Most of
 them are already taken, gladly welcomed into
 hundreds of tasteful homes, where they 123456

For smaller sizes of this series, see pages 101-103

CAXTON OLD STYLE

72 POINT

3 A 5 a \$15 50

HEROIC
and most

60 POINT

3 A 6 a \$10 50

HUMANE
may honor

48 POINT

4 A 8 a \$9 10

DECLARED
that a system

CAXTON OLD STYLE

36 POINT

5 A 10 a \$6 70

GOVERNMENT
When, in the '72

30 POINT

6 A 12 a \$5 15

HEROIC PATRIOTS
When, in the course
of human events, 30

24 POINT

8 A 16 a \$4 90

SOLID GOVERNMENT
When, in the course of
human events, it becomes
necessary that one 1892

18 POINT

10 A 20 a \$3 65

REVOLUTIONARY FATHERS
When, in the course of human
events, it becomes necessary for
one people to dissolve the 6412

CAXTON OLD STYLE

12 POINT

18 A 12 A 50 a \$4 75

SOME FACTS ABOUT QUEER BIRDS THAT
ARE FOUND IN SOUTHERN NEW ZEALAND

IN this fine country there still exist several species of wingless birds and others became extinct not more than a century ago. The gigantic dinoris, or "terrible bird," was once numerous, and ranged on the plains and hillsides. It was ten or eleven feet high and was akin to the Australian cassowary and African ostrich

8 POINT

24 A 18 A 64 a \$3 70

BECOMES DOMESTICATED
WHEN CAPTURED YOUNG

THE emu which has grown up wild is difficult to approach, and is so strong and swift that it is very rarely caught. It eats voraciously, and, like its kinsman, the African ostrich, swallows anything that it can get within its beak. This bird is distinguished by the rudimentary nature of its wings, which are useless either for flight or defense. Its legs are stout, and the inner toe armed with a sharp powerful claw.

6 POINT

32 A 24 A 100 a \$4 45

MY SHIP AT SEA.

[FROM THE BOSTON GLOBE.]

MY ship sails on the ocean brim,
With mast and cordage stout and trim;
With sails unfurled and colors gay,
It sails by night and sails by day;
'Tis freighted, Oh, so preciously,
My ship at sea.

Oh, ship of mine, come home to me,
No longer toss on life's rough sea;
It seems long since you sailed away.
With weary eyes from day to day
I've watched for you so longingly,
My ship at sea.

E. M. C.

10 POINT

18 A 12 A 50 a \$3 50

THE KIWI AND THE WEKA ARE BIPEDS OF THE
MOA KIND; THAT IS, "APTERYGAS" OR WINGLESS

THEY sleep or are inactive in the daytime, but in the twilight run about in a very quiet and cautious manner. Their lack of wings is compensated for by swiftness of foot. Indeed, the name "ocydrome," or swift-runner, has been given to some species. When they run they take long strides, with the neck stretched out and the body leaning forward. When disturbed

FRANKLIN OLD STYLE No 79

FRANKLIN
 IN THE
 PRESS ROOM

BY
 G. PERKINS
 C. AND J. P.

BRAINTR
 CHAPMAN & CON
 1902

A title page set in Old Style No. 79

See
 Opposite
 Page

MARIE
 GRIND

THE STORY OF A HARD
 WORKING GIRL'S LIFE



SOME VICISSITUDES OF A
 BUTTERFLY EXISTENCE IN
 A CROWDED METROPOLIS

A cover page set in Old Style No. 79

A Popular
 Old Style
 Series

FRANKLIN OLD STYLE No 79

36 POINT

8 A 4 A 14 a \$8 79

ROCKED HEARTLESS
Booming Cannon Roar

24 POINT

12 A 8 A 28 a \$6 99

HARDY ORACLE RESCINDED
Ecclesiastical 12903 Entertainers

18 POINT

12 A 8 A 32 a \$5 06

GRAND RIDING BEYOND BLACKSTONE
Roadways and Boulevards Smooth as Glass

14 POINT

20 A 10 A 50 a \$5 21

GROCERIES OR HARDWARE BRACES OR BUTTER
Everything Grand for Painstaking Female Shoppers

12 POINT

28 A 16 A 62 a \$5 21

AMERICAN PRODUCT
MODERN FASHION
Unique Type Designs

10 POINT

40 A 20 A 80 a \$4 81

ROMAN LETTERS PLEASED
POPULAR PRINTERS
Hundreds of Years Before

8 POINT

40 A 20 A 90 a \$4 17

ROMEO AND JULIET IN BOSTON
SINCERE \$2.30 REGRETS
Longing for the Paying Boarders

6 POINT

40 A 20 A 100 a \$3 60

CONGRESS ADJOURNED IN FEBRUARY
LEGISLATURE IN SEPTEMBER
Presidential Message Expected in March

OLD STYLE No 83

60 POINT

3 A 6 a \$10 25

SUN Baths

12 POINT

25 A 50 a \$4 00

DRESS SUITS AND OVERCOATS
MADE TO MEASURE

We have in stock a large and complete assortment of LIGHT WEIGHT clothing for men and boys of all ages and sizes ; and prices to suit the most exacting customer

22 POINT

6 A \$0 75 8 A 16 a \$3 50

WINTER SHOES, RUBBERS,
and Boots also have a conspicuous
place in our store. Call and see

10 POINT

25 A 75 a \$3 80

REDUCTION SALE OF FURNISHING GOODS
UNUSUALLY FINE VALUES

Have just received a large and varied assortment of Neckwear of the LATEST STYLES and patterns, coming direct from the manufacturers. I am confident that they will be received with merited approbation

30 POINT

4 A \$1 00 6 A 12 a \$5 60

GUARDSMEN
Outlandish Treatment

The smaller sizes also shown on pages 112 and 113

OLD STYLE No 83

42 POINT

3 A 6 a \$6 05

BURNT Houses

8 POINT

30 A 150 a \$4 75

ATHLETIC SPORTING GOODS, LAWN TENNIS SETS
AND GYMNASIUM EQUIPMENTS

The season of out-door sports has now opened. We are prepared to supply Gymnasiums, Athletic Clubs and Associations with everything needful for outdoor or indoor exercise and amusement. An exceptionally fine lot of BASE BALL SUITS, fast colors and non-shrinkable, ready made or you can have them made to order, any color or combination desired. Our receipts for the sale of these goods are evidence of their worth

18 POINT

8 A \$0 55 10 A 20 a \$2 95

RIVERSIDE MANSION HOSTELRY is the favorite stopping-place of Clubmen and Horsemen of this city. This old and famous hotel has long been known for the excellent

6 POINT

30 A 150 a \$4 00

DARKTOWN'S POLITE SOCIETY EXPRESS THEIR OPINION IN
THE MATTER OF THUMB CHEWING

It is not considered good form in Darktown's polite society to violate the rules of the prize ring and chew a lady's thumb. Mr. Johnson, one of the participants in a social controversy that ended in a free fight in his bachelor quarters, says most emphatically that he won't stand around and watch a gentleman chew any lady's thumb. WE SHOULD HOPE NOT. A gentleman addicted to the habit of chewing the thumbs of his lady friends is ill-bred and censurable, and it is very proper for other gentlemen to remonstrate with him and show him the error of his ways. If he is not amenable to reproof and refuses to eschew the habit, we must say he is no gentleman.

24 POINT

6 A \$0 95 8 A 16 a \$4 75

Unprovisional Government
PROHIBITED

The smaller sizes also shown on pages 112 and 113

PARTHENIAN SERIES

72 POINT

3 A 6 a \$17 25

SIRENED
Blonde

60 POINT

3 A 5 a \$12 10

GRANT
Evening

48 POINT

3 A 6 a \$9 60

ENDURE
Columbus

PARTHENIAN SERIES

36 POINT

4 A 8 a \$6 50

FREE CUBA
For Key West

24 POINT

6 A 12 a \$4 65

MODERN CHARM
Latest Photographs
United States Bank

18 POINT

8 A 16 a \$4 15

GENERAL WHEELER
Unconcerned Ambitions
Observe a Golden Rule

12 POINT

12 A 24 a \$3 00

EVENING TEA
Public Buildings
United Kingdom

10 POINT

16 A 32 a \$2 60

BEAUTIFUL SHORE
From Summer Resort
New Wedding Dresses

9 POINT

16 A 32 a \$2 55

BUSINESS CHANCE
Good Business Gowns
Bank Accounts Small
1234567890

6 POINT

24 A 48 a \$2 75

IMPROVING RESTAURANT
AMERICAN EXPRESS
United States Bank Building
Leads to Eternal Happiness
1234567890

FRENCH OLD STYLE No 2

72 POINT

3 A 4 a \$14 00

PUBLIC
Guard 8

60 POINT

4 A 5 a \$12 50

HEROES
Ending 98

48 POINT

4 A 7 a \$8 50

FRANKLIN
When from
Debaters 76

FRENCH OLD STYLE No 2

36 POINT

5 A 9a \$6 00

SOUND FACTS
When a natural
cause forces the
people to rise 82

30 POINT

7 A 12a \$5 75

HAIL COLUMBIA!
When, in the course
of human events, it
will be necessary 65

24 POINT

10 A 20a \$5 75

TRUE GOVERNMENT
When, in the course of
time, it became the sad
duty for one people to
dissolve the bands 260

FRENCH OLD STYLE No 2

20 POINT

14 A 28 a \$5 50

OUR RIGHTS WE PROCLAIM
 When, in the course of events, it becomes necessary for one people to dissolve the bands which have connected them with another, and to assume, among the powers 26

18 POINT

18 A 36 a \$5 00

DECLARE POLITICAL INDEPENDENCE
 When, in the course of human events, it becomes necessary for one people to dissolve the bands which have connected them with another, and to assume, among the powers of the earth, the separate and equal station to which the laws of nature and of 324098

12 POINT

20 A 10 A 60 a \$5 00

LIFE, LIBERTY, AND THE PURSUIT OF HAPPINESS
 WHEN, in the course of human events, it becomes necessary for one people to dissolve the political bands which have connected them with another, and to assume, among the powers of the earth, the separate and equal station to which the laws of nature and of nature's God entitle them, a decent respect to the opinions of mankind requires that they should declare the causes which impel them to the separation. We hold these truths to be self-evident 12345

FRENCH OLD STYLE No 2

10 POINT

24 A 12 A 75 a \$4 70

DERIVE POWER FROM THE CONSENT OF THE GOVERNED

WHEN, in the course of human events, it becomes necessary for one people to dissolve the political bands which have connected them with another, and to assume, among the powers of the earth, the separate and equal station to which the laws of nature and of nature's God entitle them, a decent respect to the opinions of mankind requires that they should declare the causes which impel them to the separation. We hold these truths to be self-evident, that all men are created equal; that they are endowed by their Creator with certain rights 1234567890

7 POINT

30 A 15 A 90 a \$4 60

EQUAL STATION AMONG THE POWERS

WHEN, in the course of human events, it becomes necessary for one people to dissolve the bands which have connected them with another, and to assume, among the powers of the earth, the separate and equal station to which the laws of nature and of nature's God entitle them, a decent respect to the opinions of mankind requires that they should declare the causes which impel them to the separation. We hold these truths to be self-evident, that all men are created equal; that they are endowed by their Creator with certain unalienable rights; that among these, are life, liberty, and the pursuit of happiness. That, to secure these rights, governments are instituted among men, deriving their just powers from the consent of the governed; that whenever any form of government becomes 1234567

6 POINT

30 A 20 A 100 a \$4 00

COLONIES DECLARE INDEPENDENCE

WHEN, in the course of human events, it becomes necessary for one people to dissolve the political bands which have connected them with another, and to assume, among the powers of the earth, the separate and equal station to which the laws of nature and of nature's God entitle them, a decent respect to the opinions of mankind requires that they should declare the causes which impel them to the separation. We hold these truths to be self-evident, that all men are created equal; that they are endowed by their Creator with certain unalienable rights; that among these, are life, liberty, and the pursuit of happiness. That, to secure these rights, governments are instituted among men, deriving their just powers from the consent of the governed; that, whenever any form of government becomes destructive of these ends, it is the right of the people to alter or to abolish it 123456789

8 POINT

30 A 15 A 90 a \$4 60

POLITICAL BANDS DISSOLVED FOR WELFARE OF OUR COUNTRY

WHEN, in the course of human events, it becomes necessary for one people to dissolve the political bands which have connected them with another, and to assume, among the powers of the earth, the separate and equal station to which the laws of nature and of nature's God entitle them, a decent respect to the opinions of mankind requires that they should declare the causes which impel them to the separation. We hold these truths to be self-evident, that all men are created equal; that they are endowed by their Creator with certain unalienable rights; that among these, are life, liberty, and the pursuit of happiness. That, to secure these rights, governments are instituted among men, deriving their just powers from the consent of the governed; that, whenever any form of government becomes destructive of these ends 12345678

RONALDSON CONDENSED

48 POINT

5 A 8 a \$5 90

SOBER Minded GIRL

36 POINT

7 A 12 a \$5 25

Northern PATROL Stations

30 POINT

8 A 14 a \$4 15

IMPORTANT PERSON
Mediocrity's Dictatorial Behavior

24 POINT

10 A 18 a \$3 60

PROTESTS
Crossing Bayonets

12 POINT

22 A 45 a \$2 70

YOUTHFUL ADMIRER
Treading on Enchanted Ground
Dream of Fairyland

8 POINT

30 A 60 a \$2 50

SCIENTIFIC INCONGRUITY
Cherished Hopes are Frequently Shattered
Centuries of Sanguine Expectation
1 2 3 4 5 6 7 8 9 0

18 POINT

14 A 28 a \$3 15

RESTORATION
Luxuries of Relaxation

10 POINT

26 A 52 a \$2 55

INTIMIDATE & BUGBEAR
Ghost Story and Scarecrow Retailers
Improved Burglar Alarm

6 POINT

36 A 70 a \$2 50

EXCELLENCE IN WORKMANSHIP
Trustworthy Dealing with the World and his Wife
Untainted by Equivocation
1 2 3 4 5 6 7 8 9 0

OLD STYLE CONDENSED No 4

48 POINT

6 A 10 a \$5 60

SECTION CYLINDER
Practical Automatic Registers

42 POINT

6 A 10 a \$4 05

REAL FRIEND BANNER
Gratitude Rewards Human Hearts

36 POINT

10 A 15 a \$4 50

USEFUL PRECIOUS METAL
Having Intrinsic and Exchange Values

24 POINT

15 A 20 a \$3 60

KIMBERLEY DIAMOND EXCHANGE
South African Exploring and Mining Companies

18 POINT

20 A 30 a \$3 30

CHRISTMAS PRESENT
Santa Claus Likes Little Ones
1 2 3 4 5 6 7 8 9 0

12 POINT

25 A 40 a \$2 40

EVERY HUMAN HEART FINDS
Consolation and Inspiration in Music
1 2 3 4 5 6 7 8 9 0

OLD STYLE CONDENSED No 122

72 POINT

3 A \$4 65 3 A 5a \$9 50

NOT TO Land

60 POINT

3 A \$3 50 3 A 6a \$7 95

Boys AND MEN

48 POINT

3 A \$2 45 3 A 6a \$5 75

DOG AT Home 82

44 POINT

3 A \$2 00 3 A 6a \$4 80

HIGH ART LOVER
Crossing 94 Swords

42 POINT

3 A \$1 75 3 A 6a \$3 85

PEACH OR ORANGE
Expensive 26 Blossoms

OLD STYLE CONDENSED No 122

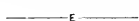

36 POINT

4 A \$1 45 4 A 8 a \$3 70

FIGHTING FOR Freedom

* 30 POINT

5 A \$1 25 7 A 11 a \$4 50

THEIR STANDARD Unfurled

24 POINT

6 A \$1 00 6 A 12 a \$2 65

SUMMER NIGHTS Entertainments

20 POINT

8 A \$1 00 8 A 16 a \$2 55

Electric Burglar ALARM INSTRUMENTS

18 POINT

10 A \$0 90 10 A 20 a \$2 50

UNIVERSITY GIRLS ON THE FORM GROTESQUE
Mountain Freedom is Declared 465

12 POINT

16 A \$0 80 16 A 32 a \$2 00

GENTLE GERMAN MAIDENS
Attractive and Inviting

9 POINT

24 A 48 a \$2 15

AMERICA'S COURAGEOUS ABILITIES
Tested During the Spanish War
1234567890

10 POINT

20 A \$0 75 20 A 40 a \$2 05

PATRIOTS RESCUED IRISHMEN
Strict Attention in the Ranks

8 POINT

32 A 64 a \$2 65

ENGLISH MINERALOGICAL RESEARCHES
Examinations for School Children
1234567890

OLD STYLE CONDENSED No 120

42 POINT

4 A \$2 75

FINE MORNING

36 POINT

5 A \$2 85

SELECT 5 STORE

32 POINT

6 A \$2 55

MANILA GENERALS

30 POINT

8 A \$2 40

DESTROY MANUSCRIPT

24 POINT

8 A \$1 95

FINE PEAR

20 POINT

12 A \$2 00

ARBITRATION

18 POINT

16 A \$2 00

ELECTRIC PLANT

16 POINT

16 A \$1 55

HEROIC REPUBLIC

12 POINT

18 A \$1 35

LIGHTNING EXPRESS

10 POINT

24 A \$1 30

HARMONIOUS GRUMBLING

9 POINT

24 A \$1 15

POCKET MATCH SAFES
WORKMANSHIP GUARANTEED

8 POINT

32 A \$1 25

HONORABLE DIPLOMATS
DISTRIBUTE GREATER EMOLUMENTS

1234567890

1234567890

OLD STYLE CONDENSED No 40

36 POINT 7 A \$3 60
MISERS

24 POINT 12 A \$3 50
HURTFUL

20 POINT 18 A \$3 70
SPITZ DOGS

16 POINT 22 A \$3 10
TRUE WOMEN

12 POINT 30 A \$2 50
SACRED MEMOIRS

30 POINT 10 A \$3 85
CHINESE

22 POINT 16 A \$3 70
MANIFOLD

18 POINT 22 A \$3 30
YOUNG TREES

14 POINT 22 A \$2 75
SUMMER GOSSIP

10 POINT 36 A \$2 35
HARVESTING JUBILEE

EDINBURGH TITLE

36 POINT 7 A \$4 65
RAILROADER

24 POINT 10 A \$3 00
MUSICAL CORNET

20 POINT 12 A \$2 50
MOTHERS

14 POINT 18 A \$2 00
ASKED PROMPT

10 POINT 20 A \$1 50
PRACTICE FOR RACES

16 POINT 18 A \$2 00
ROAD HOUSE

12 POINT 16 A \$1 50
FIGURING LOSSES

9 POINT 22 A \$1 50
REPAIRED OR ADJUSTED

1 2 3 4 5 6 7 8 9 0

1 2 3 4 5 6 7 8 9 0

OLD STYLE No 43

42 POINT

5 A \$4 60

SUPERFINE

36 POINT

5 A \$3 80

UPHOLDING

30 POINT

8 A \$3 60

FIENDS

24 POINT

10 A \$3 45

BARREN

22 POINT

12 A \$3 05

PEOPLED

20 POINT

12 A \$2 85

HYMNALS

16 POINT

14 A \$2 40

MACHINIST

12 POINT

18 A \$1 95

PROTECTIONIST

OLD STYLE TWO-LINE

24 POINT

12 A \$3 00

MODERN CRUISERS

20 POINT

14 A \$2 50

GRAND OCEAN RACER

16 POINT

16 A \$2 00

BOMBARDED

1 2 3 4 5 6 7

12 POINT

16 A \$1 50

ANCIENT FORTS

1 2 3 4 5 6 7 8 9 0

FRENCH ELZEVIR No 1

—A-F—

48 POINT

5 a \$2 66 4 A 5 a \$7 34

RICH Markets

42 POINT

6 a \$1 76 5 A 6 a \$5 66

Burnished SIGNAL

24 POINT

10 a \$1 12 8 A 10 a \$4 00

AMERICAN Type Founders

18 POINT

20 a \$1 50 14 A 20 a \$4 31

Greater New York POLITICIANS

14 POINT

20 A 10 A 50 a \$5 00

HUDSON RIVER STEAMERS MAKE FAST TRIPS
Excursions EVERY FOUR HOURS in August

12 POINT

28 A 16 A 62 a \$5 00

GREAT ROMAN CITIZEN
CHARIOT RACES
Thursday 26th October

10 POINT

40 A 20 A 80 a \$4 75

LONDON FOGS SURPASSING
THICKNESS IMMENSE
Curfew Must Ring Tonight

6 POINT

30 A 20 A 100 a \$4 00

INEXPENSIVE BREAKFAST CHOCOLATES
NICE CREAM AND BISCUITS
Every Morning Throughout the Season

8 POINT

40 A 20 A 90 a \$4 00

SOME PEOPLE WERE BORN WEALTHY
USUALLY EARLY IN YEARS
When Avoidance Was Impossible

FRENCH OLD STYLE No 1

72 POINT

3 A \$8 40

BURNER

60 POINT

4 A \$7 60

RANCHES

48 POINT

4 A \$4 50

MEASURING

36 POINT

5 A \$3 00

HINGES

30 POINT

7 A \$2 90

BURNISH

24 POINT

10 A \$2 80

RESOURCE

20 POINT

14 A \$2 70

CONVERSION

16 POINT

18 A \$2 50

GERMAN SAILORS

14 POINT

20 A \$2 30

HUMANE PRINCIPLE

12 POINT

20 A \$1 55

COLONIAL RESIDENCES

10 POINT

24 A \$1 60

LIBERAL VIEWS EXPRESSED

8 POINT

30 A \$1 65

DESIRE AMERICAN PRODUCTS

6 POINT

30 A \$1 25

PEACEABLE NEGOTIATIONS CONCLUDED

1 2 3 4 5 6 7 8 9 0

1 2 3 4 5 6 7 8 9 0

FRENCH OLD STYLE EXTENDED

72 POINT

3 A 5 a \$12 50

Said NO

60 POINT

4 A 5 a \$11 75

HID Band

48 POINT

4 A 5 a \$7 50

Mark RING

36 POINT

4 A 8 a \$5 25

BONE Breakers

30 POINT

5 A 10 a \$4 75

Heroine NUMBER

24 POINT

6 A 12 a \$4 00

HERO
Denounced

18 POINT

8 A 16 a \$3 00

RECORD
Easily Broken

12 POINT

15 A 30 a \$2 75

358 MINERS
Seriously Consider

10 POINT

18 A 36 a \$2 75

NUMBER 246
Desires Wardens Pardon

RONALDSON EXTENDED

48 POINT

4 A 6 a \$8 45

FOUR Girls

36 POINT

5 A 8 a \$6 55

Round NESTS

30 POINT

6 A 10 a \$5 40

STATED
National Revenue

24 POINT

8 A 12 a \$4 65

WAVE
Departing

18 POINT

10 A 16 a \$4 00

PARENT
Loving Child

12 POINT

18 A 28 a \$3 50

MEMORIALS
Literary Societies
Fashionable

10 POINT

20 A 30 a \$3 00

INDUSTRIOUS
Determinate Scholar
Pushed Ahead

8 POINT

22 A 32 a \$2 70

MELODRAMA
Composer and Performer
Loudly Applauded
1 2 3 4 5 6 7 8 9 0

6 POINT

25 A 40 a \$2 45

MORNING SQUEALER
Latest Sensational Newspaper
Calumnious Articles
1 2 3 4 5 6 7 8 9 0

OLD STYLE EXTENDED

48 POINT

4 A 6 a \$13 00

ONE Line

36 POINT

4 A 6 a \$6 00

Leader RUSH

24 POINT

6 A 10 a \$5 00

TROUBLES
Customary Tribute

18 POINT

9 A 12 a \$3 50

CHURCH NEWS
Transubstantiation Ethics

12 POINT

14 A 22 a \$3 50

MINUTES
Dramatic School
Elocutionists

10 POINT

16 A 22 a \$3 00

AMBITIOUS
Scholars' Recitation
Applauded

8 POINT

20 A 30 a \$3 00

MUNCHAUSEN
Writer of Circus Poster
Facts For Fiction
1234567890

6 POINT

24 A 30 a \$2 75

SUMMER VERDURE
Smiling Rainbow'd Meadow
Drooping Blossoms
1234567890

OLD STYLE BOLD

48 POINT

4 A 6a \$15 00

HE Dug

36 POINT

4 A 6a \$9 50

GETS
Sure Tips

24 POINT

5 A 7a \$6 00

COLUMBIA
Good Country

18 POINT

7 A 10a \$4 50

PIRATICAL
Mysterious Person

12 POINT

14 A 18a \$4 00

MASTIFF
Dog Howled

10 POINT

15 A 20a \$3 50

DRUNKARD
Foolish Dispute

8 POINT

18 A 24a \$3 50

CALAMITY
Howlers Muzzled
1234567

6 POINT

16 A 22a \$3 00

CONGRATULATE
The Vigilant Officer
12345678

OLD STYLE ANTIQUE No 112

48 POINT

4 A \$5 00

FLORIDA

42 POINT

5 A \$4 80

PRINTERS

36 POINT

7 A \$4 50

PREVENTED

24 POINT

10 A \$3 75

FOREST SCENES

20 POINT

12 A \$3 15

WEEKLY SPECIMEN

18 POINT

14 A \$2 45

STEAMBOAT EXCURSIONS

12 POINT

18 A \$1 80

UNIVERSAL PRINTING MACHINE

1 2 4 6 7 8 0

OLD STYLE ANTIQUE

48 POINT NO 40

4 A 6 a \$8 00

BROADSIDE
Stone Arches

36 POINT NO 40

6 A 9 a \$7 10

THE WAYSIDE
Hunting Grounds

30 POINT NO 40

8 A 12 a \$6 00

LOUIS FAVAWALE
Designer of Fashions

24 POINT NO 120

8 A 16 a \$5 80

DESIRED FLOWER
Beautiful Rose Gardens

20 POINT NO 120

10 A 20 a \$4 60

HANDSOME ROMANCER
Southern Californian Legends

OLD STYLE ANTIQUE

18 POINT NO 120

12 A 24 a \$4 30

ROMAN WAS FIRST USED IN the Netherlands about 1472. Being introduced into the Netherlands by Johannes de Westfalia, who, it is said, brought it from Italy in 1234

12 POINT NO 120

16 A 32 a \$2 85

ROMAN WAS FIRST USED IN THE NETHERLANDS about 1472. It was introduced into the Netherlands by Johannes de Westfalia, who, it is said, brought it from Italy in the year 1472. He located at Louvain, and after a number of works in semi-Gothic, published in 1483 an edition of Aeneas Silvius in the Italian letter. His font is elegant 890

10 POINT NO 120

18 A 36 a \$2 35

ROMAN WAS FIRST USED IN THE NETHERLANDS about 1472. It was introduced into the Netherlands by Johannes de Westfalia, who, it is said, brought it from Italy in the year 1472. Then located at Louvain, and, after a number of works in semi-Gothic, published in 1483 an edition of Aeneas Silvius in the Italian letter. His font is elegant, and rather a lighter face than most of the Roman fonts of other countries. This printer seems to have been the only one in the Low Countries who used this type during the fifteenth century; nor 123456

8 POINT NO 120

20 A 40 a \$2 10

ROMAN WAS FIRST USED IN the Netherlands in 1472. It was introduced into the Netherlands by Johannes de Westfalia, who, it is said, brought it from Italy in the year 1472. He located at Louvain, and, after a number of works in semi-Gothic, published in 1483 an edition of Aeneas Silvius in the Italian letter. His font is elegant, and rather a lighter 123456

6 POINT NO 120

24 A 48 a \$2 00

ROMAN WAS FIRST USED IN THE Netherlands in 1472. It was introduced into the Netherlands by Johannes de Westfalia, who, some say, brought it from Italy in the year 1472. He located at Louvain, and after a number of works in semi-Gothic, published in 1483 an edition of Aeneas Silvius in the Italian letter. His font is elegant, and rather a lighter face than most of the early Roman fonts of other countries. This printer appears to have been the only one in the Low Countries who used this type during the fifteenth cen-12345

OLD STYLE TITLE

36 POINT

4 A 7 a \$6 85

DYNAMO
Great Progress

30 POINT

6 A 9 a \$6 25

ELECTRIC
Lighting Triumph

24 POINT

8 A 12 a \$5 50

ASTRONOMER
Heavenly Observation

18 POINT

12 A 22 a \$5 25

MODERN WONDER
Musical Selections Repeated
Automatically

14 POINT

18 A 30 a \$5 00

STRIKING LIKENESS
Instantaneous Photograph Produced
Sunshine Necessary

—c—

OLD STYLE TITLE

12 POINT

22 A 32 a \$4 95

ANTE-ADAMIC RESEARCH
Sciolistic Theory of Human Organisms
Dominance of Monkeyism

10 POINT

25 A 42 a \$4 35

SELF-ACTING TELEPHONES
Instructive to the Egotistical and Self-conceited
Hearing Sharpened and Made Acute
Electrical Chatterbox

9 POINT

25 A 42 a \$3 90

OBSERVATIONS AFTER SUNDOWN
Youth's Glittering Flittings or Old Men's Experience
Courtships and Merry-Making
Selecting Partners

8 POINT

25 A 42 a \$3 90

THE TRAILING-SKIRT NUISANCE
Warranted Eventually to Kill every Devotee of Fashion
Cheap and Inexpensive Sweepers for Cities
Unsightly but Useful

7 POINT

25 A 42 a \$3 85

UNIVERSAL MODERN MARTYRS
Wasp-Waisted Feminines and Fashion's Daily Followers
Exquisite Dandies and Shoe-Pinched Damsels
High-heeled Promenaders

6 POINT

30 A 52 a \$3 75

NOTES ON THE LABOR QUESTION
Competency Speedily Acquired by Distributing Public Property
Views of the Confirmed Loafers Do-Nothing Society
Toil Reduced to a Minimum

1 2 3 4 5 6 7 8 9 0

ROMAN No 44

60 POINT

4 A 4 a \$8 95

RESIDE
Declare 6

LINING ROMAN No 153

48 POINT

4 A 5 a \$7 50

REPORTED
When, in this
year of our 18

36 POINT

4 A 3 A 5 a \$5 50

DISCONTENTS
WHEN, in time, it
is needful for 572

LINING ROMAN No 153

30 POINT

5 A 3 A 7 a \$4 60

DESIRE FREEDOM
WHEN, in time, it be-
 comes needful for one
 people to dissolve 84

24 POINT

6 A 4 A 10 a \$4 25

PRECIOUS DOCUMENTS
WHEN, in course of time, it
 becomes necessary for one
 people to break the bands
 which have joined them to
 another, and to assume 12

18 POINT

10 A 4 A 16 a \$3 25

DECLARES INDEPENDENCE
WHEN, in the course of events, it
 becomes necessary for one people
 to dissolve the bands which have
 joined them with another, and to
 assume, among the powers of 53

FULL FACE No 123

48 POINT

3 A 6 a \$9 20

BEAR Meat

42 POINT

4 A 8 a \$6 80

Great KENNEL

30 POINT

6 A 12 a \$5 80

NATIONS Admired

24 POINT

8 A 16 a \$4 70

Hero Then PRACTICES

18 POINT

10 A 20 a \$4 25

**PROMOTED
River Pirates**

14 POINT

12 A 24 a \$3 40

**SHORT NIGHT
Longer Evening**

12 POINT

12 A 24 a \$2 60

**LITTLE CRUMBS
American Heroism**

11 POINT

18 A 36 a \$2 95

**SPANISH RESOURCES
Sandbanks of Santiago**

10 POINT

18 A 36 a \$2 75

**MAGNETIC MACHINES
Attract Great Attention**

9 POINT

18 A 36 a \$2 55

**REPUBLICAN DOCTRINE
Proclaiming Emancipation**

8 POINT

24 A 48 a \$3 25

**FINE ART EXHIBITION
Postal Information Guides**

7 POINT

24 A 48 a \$2 80

**RETURNED SOLDIERS GIFT
Rejoicing at Family Reunions**

6 POINT

24 A 48 a \$2 55

**SPORTIVE DEMONSTRATIONS
Memorable Scenes are Reproduced
1234567890**

5½ POINT

24 A 48 a \$2 75

**RAILROAD FREIGHT CONTRACT
Cornmeal, Wheat and Rye Shipments
1234567890**

BOLDFACE SERIES

— D E —

* 48 POINT No 114

4 A 4 a \$8 30

KING Rulers

* 36 POINT No 114

4 A 8 a \$5 20

Banker CONVICT

30 POINT No 120

6 A 12 a \$5 25

**FARM MACHINERY
Saves Granger Labor**

24 POINT No 120

10 A 20 a \$4 85

**GREAT MEN
Cuba Liberty**

12 POINT No 120

12 A 24 a \$2 60

**LAUGHING GIRLS
Snow Covered Walk**

10 POINT No 120

18 A 36 a \$2 80

**AMERICAN TRIUMPHS
Move Victorious Onward**

8 POINT No 120

24 A 48 a \$3 10

**IMPROVED SHOEMAKING
Fashionable Ladies Footwear**

6 POINT No 120

24 A 48 a \$2 30

**UNEARNED FORTUNES ACQUIRED
Bold Liberty Enlightening the World**
1234567890

18 POINT No 120

12 A 24 a \$4 55

**MICROSCOPIC
Beautiful Stars**

11 POINT No 120

18 A 36 a \$2 90

**SURPRISED SOLDIERS
Wounded Heads Dressed**

9 POINT No 120

24 A 48 a \$3 00

**BRILLIANT DECORATION
Great Tri-Annual Horse Show**

7 POINT No 120

24 A 48 a \$2 60

**ANNUAL CALEDONIAN SPORTS
Blooded Steed Blue Ribbon Parade**

5½ POINT No 120

24 A 48 a \$2 65

**SAVED THROUGH MANY BATTLES
Multitudes Encored Famous Generals**
1234567890

CONDENSED TITLE No 123

* 54 POINT

4 A 5 a \$8 00

TIRE Makers

* 48 POINT

4 A 6 a \$7 00

Minstrel SONG

42 POINT

5 A 10 a \$7 55

FISHING Tackles

36 POINT

6 A 12 a \$7 15

Army MUSTERING

30 POINT

8 A 16 a \$5 50

PRINTERS Help Improve

24 POINT

12 A 24 a \$4 75

Scholars WENT

18 POINT

10 A 20 a \$3 05

Retailed IMPORT

14 POINT

12 A 24 a \$2 60

STEAMERS Discover

12 POINT

18 A 36 a \$3 10

SAILOR On Stormy Sea

10 POINT

24 A 48 a \$2 95

LAUGHABLE PERFORMER Tired People Form Company

8 POINT

24 A 48 a \$2 50

SUMMER FRUITFUL RIPENING Wasted Occasion during Springtime

6 POINT

24 A 48 a \$1 95

ASTONISHING TYPOGRAPHIC INVENTION Great Schemes Receive Liberal Endorsements

5 POINT

32 A 64 a \$2 40

ARMIES MUST NOT EXCEED FOURTEEN HUNDRED MEN Very Doubtful Circumference of the Terrestrial Sphere Economical Democratic State Convention

1234567890

1234567890

CONDENSED ALDINE No 150

72 POINT

4 A 6 a \$8 00

GRAND Health Tonics

60 POINT

5 A 7 a \$7 00

Pleasant Summer NIGHT

48 POINT

6 A 10 a \$6 30

Uniform EXCHANGE Measure

36 POINT

10 A 15 a \$6 00

BANK Discount

30 POINT

10 A 15 a \$4 00

Gymnastic POINTS

20 POINT

12 A 16 a \$4 00

Potomac River BRIDGE

18 POINT

18 A 26 a \$4 00

MARBLE Heart Fire Engine

14 POINT

18 A 26 a \$3 75

HONEST BOY Advocate Principle

12 POINT

22 A 32 a \$3 50

Printer Observe GOOD MANUSCRIPT

11 POINT

24 A 36 a \$3 00

**UNIQUE POSTERS DESIGNED
Special Poster and Painting Exhibition**

10 POINT

24 A 36 a \$3 00

**WHERE SNEAKS DOMINATE
Decent Men Should Assert Their Rights**

9 POINT

24 A 36 a \$2 90

**THE STAR-SPANGLED BANNER
Message of Freedom Proclaimed to Mankind**

8 POINT

26 A 38 a \$2 80

**SKILLFUL POLITICAL WIRE PULLERS
Again Deceiving Voters by Meaningless Phrases**

7 POINT

36 A 50 a \$2 25

**PROFESSIONAL TAMBOURINE SERENADERS
Great Authors were Present from Australia and Europe**

6 POINT

30 A 60 a \$2 00

**HARD TIMES BEGET DEEP THOUGHTS
History Bears Witness as to the Veracity of Above Statement**

1 2 3 4 5 6 7 8 9 0

1 2 3 4 5 6 7 8 9 0

OPEN TITLE No 120

16 POINT

12 A 24 a \$3 65

EXTENSIVE FARMING DISTRICT
Developing Tremendous Resources

12 POINT

12 A 24 a \$2 55

REFRIGERATORS
Beautiful Products

10 POINT

18 A 36 a \$2 90

PROPHETIC EXPERT
Fashionable Street Cars

8 POINT

24 A 48 a \$2 95

REMODELED MACHINERY
Severely Condemned Makers

6 POINT

24 A 48 a \$2 20

ENTERING DESPERATE BATTLE
Severely Condemned Election Tactics
1234567890

11 POINT

18 A 36 a \$3 00

FRIVOLOUS NOTION
Dramatic Society Circle

9 POINT

24 A 48 a \$2 85

INFORMATION BUREAUS
Applicants Furnished Works

7 POINT

24 A 48 a \$2 25

SPLENDID CREAMERY BUTTER
Farmer Receiving Handsome Flowers

5½ POINT

24 A 48 a \$2 00

GUARDING WESTERN MINING CLAIM
United States Internal Revenue Department
1234567890

CONDENSED TITLE No 124

14 POINT

18 A 36 a \$3 70

PRESIDENT GRANT
Smoked Havana Cigar

11 POINT

18 A 36 a \$2 60

FASCINATING MAIDENS
Marching Through Georgia

9 POINT

24 A 48 a \$2 75

TIRED HARVESTING HAND
Reading Papers By Candlelight

7 POINT

24 A 48 a \$2 05

HAPPY AND CONTENTED HUSBAND
Discovered Roadbed For Baby Carriages
1234567890

12 POINT

18 A 36 a \$3 05

HARDWOOD BOUGHT
Splendid For Buildings

10 POINT

24 A 48 a \$3 30

PLEASANT SITUATIONS
Escaping Fast and Furious

8 POINT

24 A 48 a \$2 50

COLORED TROOPS MARCHING
Along the Rough and Stony Roads

6 POINT

24 A 48 a \$2 05

SO YANKEE DOODLE CAME TO TOWN
Remarkable and Extraordinary Incident
1234567890

TWO-LINE LETTER No 128

16 POINT

16 A \$2 30

DISPOSED PRINTING MACHINE

14 POINT

18 A \$2 20

LIGHT RUNNER

12 POINT

24 A \$2 20

KLONDIKE MINE

11 POINT

24 A \$1 95

FOREIGN POLITICS

10 POINT

24 A \$1 60

ORCHESTRA SINGER

HALF TITLE SERIES

16 POINT No 120

18 A \$2 95

TIMELY HIT

14 POINT No 120

18 A \$2 45

SIMPLE CASE

12 POINT No 120

24 A \$2 50

LODGE ROOMS

11 POINT No 120

24 A \$2 15

SHORT MEASURE

10 POINT No 120

24 A \$1 70

MOUNTAIN RANGES

8 POINT No 122

16 A 32 a \$2 30

**WELCOME PROOFSHEETS
FORWARDED BY GAIL & SMITH**

8 POINT No 120

32 A \$1 85

**MACHINE DEPARTMENTS
1234567890**

6 POINT No 120

48 A \$2 10

**REMARKABLE CONTINGENCIES
1234567890**

TWO-LINE No 151

24 POINT

10 A \$3 00

MENDER

20 POINT

10 A \$2 50

UTENSILS

18 POINT

11 A \$2 25

PREMIERS

16 POINT

12 A \$2 00

RECORDER

14 POINT

14 A \$2 00

BRIGHT MEN

12 POINT

16 A \$1 75

LIGHT RUNNER

10 POINT

16 A \$1 50

**SOUTHERN SPRINGS
1234567890**

9 POINT

18 A \$1 50

**PUGILISTIC STRUGGLE
1234567890**

CONDENSED SERIES

* 72 POINT NO 45

5 A \$9 85

PROMOTER

48 POINT NO 124

4 A \$4 05

TRADE RISKS

42 POINT NO 124

5 A \$2 90

PRECISE CORNERS

36 POINT NO 124

6 A \$2 70

FOUNDRY

30 POINT NO 124

10 A \$2 80

LAUGHING

24 POINT NO 124

12 A \$2 20

LEGISLATIVE

18 POINT NO 124

16 A \$2 00

GUITAR CONCERT

16 POINT NO 124

18 A \$2 00

ROAMING HERMIT

12 POINT NO 124

24 A \$1 85

COUNTRY MEADOWS

11 POINT NO 124

24 A \$1 50

PROVISIONS FOR ARMY

10 POINT NO 124

24 A \$1 35

UNDECIPHERABLE NOTES

8 POINT NO 124

24 A \$1 15

PICTURESQUE MANSION BUILT
1234567890

6 POINT NO 124

36 A \$1 30

HERBACEOUS TREES AND SHRUBBERY
1234567890

TWO-LINE LETTER

B-E

48 POINT No 35

5 A \$5 50

TRIBUNES

42 POINT No 35

5 A \$4 65

SPECIMENS

36 POINT No 35

6 A \$3 80

CHOIR

30 POINT No 124

12 A \$4 50

HONEST

24 POINT No 124

12 A \$3 40

DUTIFUL

22 POINT No 124

12 A \$2 80

BELIEVED

20 POINT No 124

12 A \$2 70

RARE GEMS

18 POINT No 124

12 A \$2 15

TIGER SHOW

16 POINT No 124

16 A \$2 25

BRIGHT GIRL

14 POINT No 124

18 A \$2 20

FINE SCENERY

12 POINT No 124

24 A \$2 10

MARKET REPORT

11 POINT No 124

24 A \$1 75

PRINTING MACHINE

10 POINT No 124

24 A \$1 55

CHAPEL MEETING 23

9 POINT No 124

24 A \$1 35

CLEAN PROOFSHEETS 38

TWO-LINE LETTER No 129

E

24 POINT

8 A \$2 10

COUNTRY

18 POINT

12 A \$1 90

HOT DRINKS

16 POINT

12 A \$1 50

HAIL STORMS

12 POINT

16 A \$1 50

WOUNDED MAN

11 POINT

16 A \$1 35

OCEAN STORM 89

10 POINT

22 A \$1 50

WRITING PAPER 64

CONDENSED TITLE

* 72 POINT No 46

5 A 6 a \$16 95

Sister MINE

60 POINT No 125

3 A 6 a \$8 35

ROMEO Juliet

48 POINT No 125

4 A 8 a \$6 40

CURRENT EVENTS
Caused Much Dread

36 POINT No 125

8 A 18 a \$6 60

AFTER DISHONEST MEN
Deception of Fair Widows

30 POINT No 125

10 A 20 a \$4 90

ANNIHILATE YOUR ENEMIES
Instruct Unsophisticated Maidens

CONDENSED TITLE

24 POINT NO 125 12 A 24 a \$4 00

WINTER SWEETS
Shall Bloom Again

14 POINT NO 125 18 A 36 a \$3 25

EXCURSION TICKET
Stew or Fry to Order

11 POINT NO 125 18 A 36 a \$2 40

MARRIAGE ANNIVERSARY
Enjoyed by Eloquent Tramp

9 POINT NO 125 24 A 48 a \$2 50

HOME IMPROVEMENT SOCIETY
Attended by Bachelors and Maids

7 POINT NO 125 24 A 48 a \$2 00

WHERE THE FLOWERS BLOOM LOVE
Excellent Opportunity for New Beginners
 1234567890

18 POINT NO 125 12 A 24 a \$3 25

AFTER THE TIME
Many Hearts Aching

12 POINT NO 125 18 A 36 a \$2 75

REMEMBER THE MAINE
Hypocrisy and Deceptions

10 POINT NO 125 24 A 48 a \$3 00

NEW YORK BUCKET SHOPS
Bombproof Sailors Cheering

8 POINT NO 125 24 A 48 a \$2 55

COMES MARCHING HOME AGAIN
This is the Fall of Our Discontent

6 POINT NO 125 24 A 48 a \$2 05

WINTER EVENINGS PASSED AT HOME
Tremendous Cacklings Before Daybreak
 1234567890

CONDENSED TITLE No 104

30 POINT

18 A 20 a \$6 30

Twentieth WEDDING Anniversary

24 POINT 14 A 27 a \$4 60

Annihilates GEESE

12 POINT 25 A 52 a \$3 65

SLANG PHRASES
Verbiage for City Councilmen

8 POINT 36 A 70 a \$3 25

HYPOCRISY AND DECEPTION
Stepping Stones for the Unscrupulous
 1234567890

18 POINT 18 A 27 a \$3 55

Crowded STORE in Paris

10 POINT 36 A 70 a \$3 85

SOCIAL NUISANCES
Constantly Growling Neighbors

6 POINT 36 A 70 a \$2 60

FELONIOUSLY ABSTRACTED
The Only Personal Property of the Advertiser
 1234567890

EXTRA CONDENSED

120 POINT NO 234

3 A 6 a \$12 50

BRIGHT and Sordid

96 POINT NO 234

4 A 8 a \$11 00

Klondike Miners FROZEN

72 POINT NO 234

5 A 10 a \$10 50

HUNDRED Beautiful Women

48 POINT NO 123

4 A 8 a \$5 80

DISCOVERY OF GOLD MINE
Where the Robins Nest Safely

EXTRA CONDENSED

42 POINT NO 123

5 A 10 a \$4 80

LOVING MOTHER SENDS BLESSING
Home Conventions Profusely Decorated

36 POINT NO 123

6 A 12 a \$4 70

INVOLVED MANY WEIGHTY QUESTIONS
Particular Parliamentary Document Destroyed

24 POINT NO 123

8 A 16 a \$3 65

HAPPY MAIDENS WELCOME MORNING GLORIES
Sunrise Rays Impart Lovely Blushes to Dimpled Cheeks

20 POINT NO 123

10 A 20 a \$3 10

REPUBLICAN GOVERNMENTS
Industrious Mechanics Wanted

14 POINT NO 123

12 A 24 a \$2 55

BREAKFAST TABLE MANIPULATION
Demanding Delicious California Oranges

* 10 POINT NO 123

30 A 40 a \$3 10

NORTHERN STATES INTERNATIONAL EXPOSITION
Contemplating Miscellaneous Telescopic Observations

1234567890

18 POINT NO 123

12 A 24 a \$3 00

ELASTIC ANTI-FRICTION MORALS
Bachelors Wanted to Matrimonialize

12 POINT NO 123

16 A 32 a \$2 65

ASSEMBLING OF INDUSTRIOUS LADIES
Good Recipes for Curing Fever Epidemics

* 8 POINT NO 123

40 A 50 a \$3 50

AUTOCRATIC MILLIONAIRES PURCHASING GOLD BONDS
Magnificent Catalogues Announcing Good Winter Commodities

1234567890

ROMAN EXTENDED No 120

36 POINT

4 A 8a \$8 75

RAMBLE
From Here

30 POINT

5 A 10a \$5 85

INDUSTRIAL
Great Bargains

24 POINT

6 A 12a \$5 40

HOUSEHOLDS
Memorial Service

18 POINT

8 A 16a \$5 10

VIOLET
Stray Cat

12 POINT

12 A 24a \$3 70

HIGH TIME
Cranky Player

10 POINT

12 A 24a \$2 50

RICH WIDOWS
Designing but Cute

9 POINT

16 A 32a \$2 75

DELIGHTFUL RIDE
Scented With Flowers

8 POINT

18 A 36a \$3 05

HONORED KNIGHT
Deserves Great Credit

6 POINT

18 A 36a \$2 30

DARKEST BEFORE DAY
Makes Hay When Sun Shines

5½ POINT

24 A 48a \$3 05

COMES MARCHING ALONG
Twenty Thousand Brave Tramps
1234567890

5 POINT

24 A 48a \$3 40

5 POINT ON 6 POINT

24 A 48a \$2 70

SHORT CUT FASHIONABLE
Tonsorial Artist Gleeefully Grins
1234567890

TITLE EXPANDED No 120

48 POINT

3 A 5a \$11 55

SIDney

42 POINT

3 A 5a \$8 60

FENCED
Pet Lions

36 POINT

3 A 6a \$5 60

NILE
Smile

24 POINT

4 A 8a \$4 15

MEAD
Forced

20 POINT

6 A 12a \$4 35

BLIGHT
Judge Nit

18 POINT

6 A 12a \$3 15

DIVORCE
Fine as Silk

12 POINT

10 A 20a \$2 80

FINE HOUSE
Painted in Blue

10 POINT

12 A 24a \$2 50

SWEEP CLEAN
Cyclone in Kansas

9 POINT

18 A 36a \$3 10

CURRENT REPORT
Floating on the Breeze

8 POINT

18 A 36a \$3 10

BRIGHT PROSPECT
Solicited for the Trade

6 POINT

18 A 36a \$2 65

INDEPENDENT FIRMS
Supreme Court Decisions

5½ POINT

24 A 48a \$3 50

5½ POINT ON 6 POINT

24 A 48a \$3 05

NATIONAL MISFORTUNE
Viewed by Distressed Soldier

1234567890

1234567890

EXTRA CONDENSED No 43

96 POINT

7 A \$12 60

SIGHT FOR BOYS

72 POINT

7 A \$8 40

MEMBERS

60 POINT

10 A \$8 20

DESIGNERS

48 POINT

10 A \$6 30

PRODUCTIONS

42 POINT

14 A \$4 80

ROMAN EXTRACTS

36 POINT

14 A \$3 80

LONDON PROFESSORS

24 POINT

22 A \$4 50

SPRINGTIME EXCURSION

20 POINT

25 A \$3 40

GIGANTIC CALIFORNIA TREES

12 POINT

36 A \$2 60

BOARDING HOUSE BEANSOUP DILUTION

8 POINT

52 A \$2 70

MAMMOTH EXHIBITION OF NATIONAL CURIOSITIES

6 POINT

52 A \$2 00

CONCEITED DIMINUTIVE FOLKS PROVOKING ABUNDANCE OF HUMOR

1234567890

1234567890

PART X.

Antique
Clarendon
Doric
Caledonian
Ionic

ANTIQUE CONDENSED -No 124

*72 POINT

5 A \$8 35

NUT BROWN

60 POINT

4 A \$4 20

EXPORTED RUM

48 POINT

5 A \$3 40

FASHION

42 POINT

6 A \$3 00

SECURING

36 POINT

8 A \$2 55

SERVE MAN

24 POINT

12 A \$2 40

CONTRADICTS

18 POINT

16 A \$2 30

ORNAMENTATION

16 POINT

18 A \$1 75

CAPTURE BOLD BAND

14 POINT

18 A \$1 40

REGULAR BAKING HOUR

12 POINT

24 A \$1 45

ESTABLISHED FURNISHER

10 POINT

24 A \$1 25

**MAGNIFICENT MONOCHROMES
1234567890**

8 POINT

24 A \$1 00

**BEAUTIFUL AMERICAN STEAMSHIPS
1234567890**

ANTIQUE CONDENSED No 36

60 POINT

4 A 6 a \$9 85

GUN Makers

48 POINT

5 A 10 a \$8 25

Handsome MAIDS

44 POINT ON 48 POINT

5 A 8 a \$5 95

Albion RACE Course

42 POINT

6 A 10 a \$5 25

NICE Trick

30 POINT

10 A 15 a \$4 55

MILD Weather

24 POINT

12 A 20 a \$3 95

**FRONT GATE
Haunts of Maidens**

18 POINT

15 A 25 a \$3 45

**TURKISH BATH
Nile Exploration Club**

14 POINT

15 A 25 a \$2 70

**PRAIRIE HOMES
Big Fields of Golden Grain**

12 POINT

20 A 30 a \$2 60

**MIDNIGHT RAIDERS
Consternation in Truckville**

10 POINT

25 A 40 a \$2 65

**THE MARBLE HEART
Charming Bloomer Bicycliennes
1 2 3 4 5 6 7 8 9 0**

8 POINT

30 A 50 a \$2 60

**MAGNIFICENT WONDERLAND
Yellowstone National Park Expeditions
1 2 3 4 5 6 7 8 9 0**

ANTIQUE CONDENSED No 123

60 POINT

3 A 6 a \$6 55

MOUNTAIN Stream

48 POINT

4 A 8 a \$5 75

Summer FRIENDSHIP

42 POINT

6 A 12 a \$5 55

REPUBLICAN Pyrotechnics

30 POINT

8 A 16 a \$4 40

**COMMUNICATE
Evening Gown**

24 POINT

12 A 24 a \$4 20

**ANCIENT CUSTOM
National Triumph**

18 POINT

12 A 24 a \$3 05

**HANDSOME FLOWERS
Raised in Greenhouse**

16 POINT

12 A 24 a \$2 40

**CONVENTION DELEGATE
Member Securing Ticket**

14 POINT

16 A 32 a \$2 70

**GOOD BUSINESS CHANCES
Between Dark and Morning**

12 POINT

18 A 36 a \$2 30

**FALL OF NAPOLEON TEACHES
European Commanders a Lesson**

10 POINT

24 A 48 a \$2 30

**LATEST STYLES IN LADIES SHOES
Manufactured by the Late John Smith
1234567890**

8 POINT

24 A 48 a \$2 15

**EXTRAORDINARY COURAGE TESTED
Herculean Effort Accomplished Result
1234567890**

BRETON SERIES

48 POINT

3 A 3 a \$8 00

ICE Boat

42 POINT

3 A 4 a \$5 00

**MODERN
Frame House**

24 POINT

7 A 10 a \$4 00

**UNION STATION
Great Building Complete**

18 POINT

12 A 18 a \$3 25

**EUROPEAN COUNTRY
Touring in Germany and Scotland**

12 POINT

16 A 24 a \$3 00

**HIGH BRIDGE
Over the Charles River**

10 POINT

20 A 30 a \$2 75

**BEAUTIFUL SNOW
Don't Push those Drifts Away**

8 POINT

24 A 36 a \$2 50

**RAIN EVERY SUNDAY
Laboring Hardly Every Other Day**

6 POINT

28 A 42 a \$2 25

**DOWN BY THE RIVULET
When Summer Comes Creeping Along
1 2 3 4 5 6 7 8 9 0**

ANTIQUE SERIES

*72 POINT NO 124

3 A 4a \$14 15

Her SIN

60 POINT NO 42

5 A 6a \$15 60

FIR Grove

48 POINT NO 124

3 A 6a \$8 40

Cared SURE

42 POINT NO 124

4 A 8a \$7 50

SILver

36 POINT NO 124

5 A 10a \$5 05

BIG Plot

30 POINT NO 124

6 A 12a \$4 55

Note COIN

24 POINT NO 124

10 A 20a \$4 80

High STONE

18 POINT NO 124

12 A 24a \$4 00

MEAN HABITS
Contains Arsenic

12 POINT NO 124

18 A 36a \$3 40

TICKET OPERATOR
Northwestern Routes

10 POINT NO 124

18 A 36a \$2 60

INSURGENT PRISONER
True American Generosity

8 POINT NO 124

24 A 48a \$2 90

LIFE INSURANCE POLICIES
Commercial Printing done here

6 POINT NO 124

24 A 48a \$2 35

INTRODUCING NEW MACHINES
Disregard Some Questionable Methods
1234567890

5 POINT NO 124 ON 6 POINT

24 A 48a \$1 85

DEMANDING A THOROUGH RESEARCH
Two Independent Philadelphia Manufacturers
1234567890

IONIC SERIES

48 POINT NO 122

3 A 6 a \$10 25

FISHING
Rent Main

42 POINT NO 122

3 A 6 a \$7 15

DAMAGING
Fine Harvest

36 POINT NO 120

6 A 12 a \$7 70

HANDY
Carriage

24 POINT NO 120

10 A 20 a \$5 65

CURTAINS
Fine Design

18 POINT NO 120

16 A 32 a \$4 90

STRONG WIND
Wheat Destroyed

12 POINT NO 120

18 A 36 a \$3 65

DARING SCOUTS
Famous Publication

10 POINT NO 120

18 A 36 a \$3 05

WINSOME MAIDENS
Sunshine After Storms

8 POINT NO 120

24 A 48 a \$3 10

MOURNED BY MILLIONS
When Did The Dead Sea Die

6 POINT NO 120

24 A 48 a \$2 50

EQUINE SAGACITY OBSERVED
Feline Trainers Amusing Audience
 1234567890

5½ POINT NO 120

24 A 48 a \$2 55

MAGNIFICENT AMERICAN FARMS
Are in Evidence East West North South
 1234567890

IONIC No 150

48 POINT

3 A 5 a \$7 00

TRUE Colors

42 POINT

5 A 6 a \$6 00

Inexorable JUDGE

36 POINT

6 A 10 a \$5 00

GRACEFUL Benefactor

24 POINT

7 A 11 a \$4 00

ROMAN ASCETICS
Scorned Culinary Pleasures

20 POINT

10 A 16 a \$3 50

ARTISTIC IMPROVEMENTS
Performances Warmly Complimented

12 POINT

17 A 28 a \$3 00

ORIGINAL IDEA
Deserved Recognition

10 POINT

22 A 32 a \$2 75

STRICTEST ECONOMY
Necessary for City Legislators

8 POINT

24 A 36 a \$2 50

ENGLISH ARCHITECTURE
Wanderings Through Southampton
1 2 3 4 5 6 7 8 9 0

6 POINT

30 A 45 a \$2 25

GOVERNMENT RAILROAD SERVICE
Unsurpassed Facilities for Handling Materials
1 2 3 4 5 6 7 8 9 0

DORIC No 120

48 POINT

3 A 6 a \$9 00

RICH Mine

42 POINT

3 A 6 a \$6 90

**FAST COLOR
Perfect Shade**

36 POINT

4 A 8 a \$6 40

**SNAKE
Oil Sold**

30 POINT

4 A 8 a \$5 40

**GAITER
Late Cut**

24 POINT

8 A 16 a \$5 50

**FLOWERS
Keep Sake**

18 POINT

10 A 20 a \$5 20

**NOBLEMAN
Prison Bird**

12 POINT

12 A 24 a \$2 90

**TIGER HUNTER
Fighting Elephant**

10 POINT

16 A 32 a \$2 95

**HONEST FARMER
Wearing Old Clothes**

8 POINT

20 A 40 a \$3 10

**KENTUCKY WHISKY
Excellent as Nose Paint**

7 POINT

24 A 48 a \$2 75

**BLACK EYES AND RED HAIR
Diamonds and Jewelry in Plenty**

6 POINT

24 A 48 a \$2 55

**GOVERNMENT MULE KICKED
For More Pay and Shorter Hours**

5 POINT ON 6 POINT

24 A 48 a \$2 55

**BLEAKEST SEASON ANNOUNCED
Cold Wintry Winds of December**

½ ¼ 1234567890 ½ ¼

1234567890

IONIC SERIES

B-E-F

* 48 POINT NO 30

4 A 6 a \$8 90

RICH Lands

* 42 POINT NO 159

4 A 5 a \$6 40

Liberal TERM

36 POINT NO 122

4 A 8 a \$5 20

PRODUCTS
Siberian Diamonds

30 POINT NO 122

6 A 12 a \$4 90

SHIPS
Cool Trips

24 POINT NO 122

8 A 16 a \$4 70

SILENT
Prison Halls

18 POINT NO 122

10 A 20 a \$3 70

INDIANA
National Queen

12 POINT NO 122

16 A 32 a \$3 15

REPRIMANDS
Social Reformatons

10 POINT NO 122

18 A 36 a \$2 60

SOCIAL LEADERS
Great Annual Horse Show

8 POINT NO 122

24 A 48 a \$2 60

FASHION EXHIBITION
Grand Display of Gotham Beauty

6 POINT NO 122

24 A 48 a \$2 30

BRILLIANT DECORATION
Blue Ribbon Parade of Blooded Steeds
1234567890

5 POINT NO 122

24 A 48 a \$2 60

ANNUAL CALEDONIAN GAMES
Rosy Cheeked Maids in the Matrimonial Race
1234567890

CLARENDON No 120

48 POINT

4 A 8 a \$8 30

GRAIN Binder

36 POINT

5 A 10 a \$6 40

Famous FRIENDS

30 POINT

6 A 12 a \$4 15

**RIVERSIDE TRAMWAYS
Publishing Domestic Trouble**

24 POINT

8 A 16 a \$3 35

**YOUNG HORSE
Becoming Sulky**

18 POINT

10 A 20 a \$2 95

**CONTRA COSTA
Honest Treatment**

12 POINT

16 A 32 a \$2 95

**GOOD MESSENGERS
Wonderful Hardship**

11 POINT

16 A 32 a \$2 40

**CUBAN INDEPENDENCE
Summer Comfort for Guests**

10 POINT

18 A 36 a \$2 50

**GRASP OPPORTUNITIES
Marine Insurance Company**

9 POINT

18 A 36 a \$2 00

**GRAND FUNDING OPERATION
Gigantic Accumulation of Securities**

8 POINT

24 A 48 a \$2 50

**FEVER IN SANTIAGO DE CUBA
Sickly People Forming a Company**

6 POINT

24 A 48 a \$2 05

**CONSTITUTION OF UNITED STATES
Wealth Speedily Acquired by Purchasing**

1234567890

1234567890

CLARENDON LIGHTFACE No 30

36 POINT

6 A 12 a \$5 85

EXPERT Motor Drivers

30 POINT

8 A 15 a \$5 20

Electric Mechanical WORKS

12 POINT

20 A 30 a \$2 80

PROPHETIC LORE
Cabinet Making Politician

10 POINT

30 A 40 a \$3 15

IMPULSIVE HORDE
Cowboy Business Promenade

9 POINT

30 A 50 a \$2 85

AMERICAN JOURNALS
National Educational Advantages

8 POINT

25 A 40 a \$2 20

NEWSPAPER ENTERPRISE
Unlimited Modern Perfecting Presses

6 POINT

30 A 50 a \$2 05

COTTON HAND SPINNING WHEEL
Modern Machinery Supersedes Antique Method
38 Niagara Water-Fall

5 POINT

30 A 50 a \$2 25

PIPE LINES TO PETROLEUM CENTER
Broad Tracts of Rocky Ground Cultivated by Speculator
527 Appropriate Illustrations

CONDENSED CLARENDON No 42

12 POINT

25 A 42 a \$2 75

GENIAL HOME COMFORTS
Contents of a Well-Stocked Larder

10 POINT

36 A 52 a \$2 70

AUTUMN GATHERING GARNERED
Fruit for the Benefit of Hungry Humanity

8 POINT

36 A 70 a \$2 75

SUMMER FRUITFUL RIPENINGS
Glimpse at the Contents of Nature's Cornucopia
1234567890

6 POINT

52 A 70 a \$2 50

WASTED OCCASIONS DURING SPRINGTIME
Lazy Donothing Bemoaning the Loss of Golden Opportunities
1234567890

CLARENDON CONDENSED

60 POINT No 10

3 A 4 a \$9 66

Latest CARD

48 POINT No 120

4 A \$2 80 4 A 8 a \$7 60

New MEN HERE

42 POINT No 120

5 A \$2 35 5 A 10 a \$6 55

READY AIM Target

36 POINT No 120 6 A \$2 00 6 A 12 a \$5 45

FINE MEN PAST Event

24 POINT No 120 10 A \$1 30 10 A 20 a \$3 60

CRUSHED PEAR STOLEN FRUIT Parlor Destroyed

12 POINT No 120 16 A \$0 75 16 A 32 a \$2 35

AMERICAN GOLF PLAYER TOURING THE COUNTRY Sixteenth Century Women

1234567890

30 POINT No 120 8 A \$1 60 8 A 16 a \$4 65

PRICE SOME ORDER Drinks

18 POINT No 120 12 A \$1 00 12 A 24 a \$3 00

NORTHERN HOUSE WOLVES ATTACHED Dark Spanish Beauty

10 POINT No 120 18 A \$0 70 18 A 36 a \$2 00

SOUTHERN COTTON DISTRICTS EMPLOYED NEGRO LABOR Noble Deeds Are Quickly Observed

1234567890

ANTIQUE CONDENSED

72 POINT NO 122

3 A 5 a \$10 00

CLARENDON CONDENSED No 122

60 POINT

3 A 6 a \$6 05

BEAUTIFUL Shadows

48 POINT

4 A 8 a \$5 10

Reasonable FURNISHED

36 POINT

6 A 12 a \$3 85

NORTHERN GRAZING RANCH
Marketing Meadow Products 58

24 POINT

8 A 16 a \$2 95

ELEGANT DINING
Finest Home Meals

18 POINT

12 A 24 a \$2 45

NEWLY INVENTED BOMB
Destroying Torpedo Boats
1234567890

12 POINT NO 116

20 A 30 a \$2 55

STANDARD LETTER
Excellent Condensed Series
1234567890

10 POINT NO 116

24 A 50 a \$2 70

GREAT FOREST LANDS
North American Lumber District
1 2 3 4 5 6 7 8 9 0

CLARENDON CONDENSED

60 POINT NO 10

3 A 4 a \$9 66

AMERICAN GOLF PLAYER
TOURING THE COUNTRY
Sixteenth Century Women
1234567890

SOUTHERN COTTON DISTRICTS
EMPLOYED NEGRO LABOR
Noble Deeds Are Quickly Observed
1234567890

ANTIQUÉ CONDENSED

72 POINT NO 122

3 A 5 a \$10 00

Clear RED Inks

60 POINT NO 122

3 A 6 a \$7 25

Denver GOLD Mine

48 POINT NO 122

4 A 8 a \$5 50

Northern INTERESTS

36 POINT NO 122

6 A 12 a \$5 45

SEVENTH Entertainment

30 POINT NO 122

8 A 16 a \$4 65

STATE Prison

24 POINT NO 122

10 A 20 a \$3 65

GRAND Concerts

18 POINT NO 116

15 A 24 a \$2 90

National COLLEGES

14 POINT NO 116

16 A 30 a \$2 85

Northern HOMESTEADS

12 POINT NO 116

20 A 30 a \$2 55

STANDARD LETTER
Excellent Condensed Series
1234567890

10 POINT NO 116

24 A 50 a \$2 70

GREAT FOREST LANDS
North American Lumber District
1 2 3 4 5 6 7 8 9 0

MODERN ANTIQUE

72 POINT

3 A 4 a \$11 20

MINER
Mountain

60 POINT

4 A 5 a \$10 25

RESORT
Convulsion

48 POINT

5 A 8 a \$10 90

MEETING
Administrator

MODERN ANTIQUE

42 POINT

6 A 10 a \$8 90

Patriotic LODGE

36 POINT

8 A 12 a \$8 50

**EMBROIDERY
Commission Brokers**

30 POINT

10 A 16 a \$6 40

**SECOND OUTING
Lake St. Clair Excursions**

20 POINT

12 A 20 a \$4 50

**COMBINED
Printers Album**

18 POINT

16 A 24 a \$3 90

**MEMORANDUM
Domestic Expenses**

12 POINT

20 A 40 a \$3 00

**MODERN PRINTING
Numerous Improvement**

10 POINT

24 A 50 a \$3 00

**ORNAMENTAL CARVING
Prize Compositions by Horn**

8 POINT

30 A 60 a \$3 00

**TRUMPET MANUFACTURER
Composer of Excellent Overture
1234567890**

6 POINT

30 A 60 a \$2 50

**NORTHERN LUMBER MERCHANT
Fine Pine Forest of Northern Michigan
1234567890**

MODERN ANTIQUE WIDE No 110

48 POINT

3 A 4 a \$8 90

OLD Rites

36 POINT

4 A 6 a \$7 00

Silver MINES

30 POINT

6 A 8 a \$5 60

**SKETCHING
Ground Cinnamon**

20 POINT

10 A 16 a \$4 85

**SELECTED DESIGN
Handsomest Adornments**

18 POINT

10 A 16 a \$3 75

**CUMBERLAND RIVER
Pleasant Steamboat Excursion**

12 POINT

20 A 30 a \$3 65

**DISTINGUISHED NEIGHBORS
North American Insurance Companies
1 2 3 4 5 6 7 8 9 0**

LATIN ANTIQUE No 120

48 POINT

3 A 5 a \$7 70

China BIRD

36 POINT

4 A 8 a \$5 90

MILK Crackers

30 POINT

6 A 12 a \$5 35

Household WORDS

24 POINT

8 A 16 a \$4 50

ROBUST MAIDEN
Regular Business Gowns

18 POINT

10 A 20 a \$3 65

GARDEN
Rustic Baskets

10 POINT

18 A 36 a \$2 95

HAYSEEDERS
Untutored Dunderpates

6 POINT

24 A 48 a \$2 60

IMPECUNIOSITY
Decidedly Small Bank Accounts
1 2 3 4 5 6 7 8 9 0

12 POINT

12 A 24 a \$2 45

BURDENSOME
Weighing Machines

8 POINT

24 A 48 a \$3 00

WINTER STORMS
Sweeping Hurricane Decks

5 POINT ON 6 POINT

24 A 48 a \$2 15

HARMONIOUS GATHERING
Conducted Without Pomp or Ceremony
1 2 3 4 5 6 7 8 9 0

ANTIQUE No 125

48 POINT

4 A 8 a \$9 35

FINE Horse

36 POINT

5 A 10 a \$7 90

Perilous RIDE

30 POINT

6 A 12 a \$5 80

Gray MOON Dogs

24 POINT

8 A 16 a \$4 70

UNIFORM OVERCOATS
Modern Trousers Imported

18 POINT

12 A 24 a \$4 45

REPUTATION
Honest Morals

12 POINT

18 A 36 a \$3 20

BEAUTIFUL LADIES
Evening Concert Given

10 POINT

24 A 48 a \$3 05

MEXICANS CONVERTED
Political Courage Uprising

9 POINT

24 A 48 a \$3 05

DRINKING LIGHT LIQUOR
Brightest Hopes are Fleeting

8 POINT

24 A 48 a \$2 80

CURIOUS HISTORICAL ITEM
Don't Roam Around the House

7 POINT

24 A 48 a \$2 25

EASTERN CARTILAGINOUS FISHES
Comprehend European Disintegration

6 POINT

24 A 48 a \$2 30

DETERMINED MECHANICS STRIKE
Peace Reigns Throughout the World

5½ POINT

32 A 64 a \$2 95

DISCERNING COMMENTATORS APPROVED
Numerous Excellent Graduated Nutriments

ANTIQUE EXTRA CONDENSED No 150

E-F

*96 POINT

3 A 4 a \$10 85

FOREIGN Homes

72 POINT

3 A 5 a \$8 50

Nice TOY

60 POINT

4 A 6 a \$6 50

Lonely SUIT

48 POINT

4 A 7 a \$5 00

OPERA Cloaks

42 POINT

5 A 8 a \$4 50

ELEGANT GOWN

36 POINT

7 A 11 a \$4 25

Pinafores BRAIDED

30 POINT

9 A 12 a \$4 00

Yachting COSTUME

24 POINT

11 A 17 a \$3 75

ADVERTISED Underwear

20 POINT

10 A 16 a \$3 50

STUPENDOUS Importation

18 POINT

14 A 20 a \$3 25

Choicest EMBROIDERY Bargain

12 POINT

16 A 26 a \$3 00

Desirable HANDKERCHIEF Novelties

10 POINT

20 A 32 a \$2 75

ENAMELED Limoges or English PORCELAIN

8 POINT

22 A 32 a \$2 50

COMPULSORY Disposals of Magnificent FURNITURE

1234567890

1234567890

CENTRAL ANTIQUE

54 POINT

3 A 5 a \$10 00

BIG Hens

48 POINT

3 A 5 a \$8 00

Dark RIDE

42 POINT

4 A 6 a \$7 00

GEMS Bound

36 POINT

4 A 6 a \$5 00

Enrich MISERS

30 POINT

5 A 8 a \$4 50

SIX Men

24 POINT

6 A 10 a \$4 00

DISH Cloth

18 POINT

10 A 16 a \$3 25

Danish SONG

14 POINT

14 A 20 a \$3 00

Trained HORSES

12 POINT

18 A 22 a \$3 00

GERMAN DANCERS
Excite Society Maiden

10 POINT

22 A 30 a \$2 75

BOSTON CONCERT GIRLS
Unique Amusement Created

8 POINT

24 A 36 a \$2 50

ENTHUSIASTIC KLONDIKERS
Return Sadder but Wiser Miners

6 POINT

30 A 42 a \$2 25

FROLICHSOME EUCHRE COMPANIONS
Escorts Delighted with Buxom Partners

1 2 3 4 5 6 7 8 9 0

1 2 3 4 5 6 7 8 9 0

LINING ANTIQUE SERIES

36 POINT No 40

6 A \$4 50

CHECKERED

30 POINT No 40

8 A \$3 80

PREMIERSHIPS

24 POINT No 40

10 A \$3 20

TRANQUIL WOMEN

18 POINT No 40

14 A \$2 55

FRAGRANT PERFUMERY

12 POINT No 40

25 A \$2 25

HEALTHY
SMILING FACES

8 POINT No 40

36 A \$2 00

FAMILY ACROBATS
PITCHER AND TUMBLER

6 POINT No 44

45 A \$1 60

LIBERAL COMPENSATION
ALLOWED FOR ADVERTISING SURFACE
FENCES PREFERRED

6 POINT No 42

45 A \$1 15

INDUSTRIAL DEPARTMENT
EMPLOYING BUSY BRAINS AND ACTIVE MUSCLES
IMPROVED TOOLS AND IMPLEMENTS

1234567890

10 POINT No 40

30 A \$2 00

EXCURSION
LARGE STEAMSHIP

6 POINT No 45

45 A \$1 90

ANNUAL GATHERING
MUTUAL ADMIRATION SOCIETY

6 POINT No 43

45 A \$1 30

APPROACHING DESTINATION
AGED VETERANS IN THE WARFARE OF LIFE
CONTENTED TRAVELERS

6 POINT No 41

45 A \$1 10

NOTEWORTHY OCCURRENCES
MATRIMONIAL VOWS AND ADVENT OF THE FIRST-BORN
SUMMER VISITS TO COUNTRY COUSINS

1234567890

ANTIQUE No 126

36 POINT

6 A 12 a \$6 00

EXTREME LABOR
International Brands

24 POINT

10 A 20 a \$4 95

FOSSILIZED MONUMENT
Celebrated Popular Statesmen

18 POINT

12 A 24 a \$3 60

DELIGHTFUL HOLIDAY MEMORIES
Able Statesmen Assembled in Conference

12 POINT

16 A 32 a \$2 50

ENTHUSIASTIC AUDIENCE BECAME RESTLESS
Autocratic Millionaires Purchasing Government Bonds

11 POINT

16 A 32 a \$2 20

STEREOTYPING DISPLAYS
Celebrated Historical Teacher

10 POINT

18 A 36 a \$2 35

KINDHEARTED GARDENER
Grave Diplomatic Statements

9 POINT

18 A 36 a \$2 10

COUNCILMANIC DEPARTMENT
Unscrupulous Counterfeit Method
Reversible Seamless Spring Coats

8 POINT

20 A 40 a \$2 25

DISPLAY WONDERFUL NERVE
Rocked in the Cradle of the Deep
Pensioning Wounded Combatants

6 POINT

24 A 48 a \$2 15

HEARTRENDING APPEALS TO PATRIOT
Zealously Guard Contagious Localities
Contributions from Patriotic Volunteer
Entertainments in Gymnastic Contests

5½ POINT

24 A 48 a \$2 00

REINVIGORATE DEPOPULATED NATIONALITIES
Sweet Voices Singing Requiems Over the Departed
Suburban Residences Destroyed by the Tidal Wave
Revised Histories of Celebrated Discoveries Finished

1234567890

1234567890

ANTIQUE CONDENSED

—E—

36 POINT NO 152

6 A 10 a \$5 00

Grand EUCHRE Parties

30 POINT NO 152

8 A 12 a \$4 50

NEW Scorer

24 POINT NO 152

10 A 14 a \$4 00

QUICK Games

20 POINT NO 152

12 A 16 a \$3 50

Exultant MAIDS

18 POINT NO 122

12 A 24 a \$3 50

Celebrated SINGER

12 POINT NO 122

18 A 36 a \$2 85

GENUINE Scotch Texture

10 POINT NO 122

24 A 48 a \$2 85

RENOWNED French Landscape

8 POINT NO 122

24 A 48 a \$2 35

Enterprising American COMEDIANS
1234567890

6 POINT NO 122

24 A 48 a \$1 90

Manufacturer Advances SOUND ARGUMENT
1234567890

ANTIQUE No 127

—E—

24 POINT

8 A 16 a \$5 45

DEPOSED Renegades

18 POINT

10 A 20 a \$3 90

Paying Positions CAPTURED

12 POINT

16 A 32 a \$2 95

GREAT MEMORIES
Experience Required

11 POINT

16 A 32 a \$2 45

DISCOURAGE TRAMPS
Throughout the Universe

10 POINT

18 A 36 a \$2 70

BRIGHTEST CHANCES
Produced Without Favor

9 POINT

18 A 36 a \$2 05

FAMISHED RECRUITS PERISH
Lost By Erroneous Calculations

8 POINT

24 A 48 a \$2 70

NEARING DESTROYED PARK
Multiplied Submarine Disorders
1234567890

6 POINT

24 A 48 a \$2 30

THOUSANDS DISCUSSED RETURNS
Severely Criticised Monroe Doctrine
1234567890

EXTENDED CLARENDON

30 POINT No 30

5 A \$3 65

PRINTING
WHITE

24 POINT No 30

6 A \$3 45

GOLD BANK
HESTON

20 POINT No 30

10 A \$3 70

RIGHT WORDS
FOOLERS

16 POINT No 30

15 A \$3 40

DRUMTON BANDS
AIR MASK

12 POINT No 30

20 A \$3 15

STEAMERS
REIGN

10 POINT No 32

20 A \$2 20

STEEL SHIPS
LOANED

10 POINT No 30

20 A \$2 00

PUBLIC TRUST
SCIENCE

8 POINT No 30

30 A \$2 50

GORGEOUS SPORT
HONORED

6 POINT No 30

30 A \$2 25

POLICE NIGHT STICK
EVENING CLUBS
1234567890

5 POINT No 30

30 A \$2 25

HISTORIC PERFORMANCE
ANCIENT TRAGEDIES
1234567890

ANTIQUE EXTENDED No 124

42 POINT

3 A 6 a \$10 40

SEnator

30 POINT

4 A 8 a \$6 40

MORE Life

24 POINT

6 A 12 a \$5 45

**TUBES
Finders**

18 POINT

8 A 16 a \$4 45

**FLAMES
Hot Stuff**

12 POINT

10 A 20 a \$3 65

**LIGHTING
Truck Man**

10 POINT

10 A 20 a \$2 75

**STONE JUGS
Sugar Market**

8 POINT

16 A 32 a \$3 30

**EXAMINE WELL
Fashion Reviews**

6 POINT

18 A 36 a \$2 90

**EXAMINATION FREE
Service Questions 234**

ANTIQUE EXTENDED No 122

30 POINT

4 A 8 a \$6 45

**NED
Milk**

24 POINT

5 A 10 a \$5 05

**CUBIC
Dinner**

12 POINT

8 A 16 a \$4 00

**DELPHI
One Run**

10 POINT

10 A 20 a \$3 70

**PRIMERS
Pupils 234**

LATIN EXTENDED

36 POINT

3 A 4 a \$8 65

NICE
Dinners

30 POINT

4 A 6 a \$6 90

FRIED
Pheasant

24 POINT

6 A 8 a \$6 95

GRAND
Corn Bread

18 POINT

8 A 12 a \$5 60

HOT
Clams

14 POINT

10 A 14 a \$4 95

CIDER
Oat Meal

12 POINT

12 A 20 a \$3 40

POTATOES
Baked Onions

10 POINT

18 A 24 a \$3 60

DUMPLINGS
Boiled Rock Fish

8 POINT

24 A 32 a \$3 75

BEEFSTEAK
Biscuit and Pudding

6 POINT

30 A 40 a \$3 90

CAULIFLOWER
Cheese and Mild Coffee

1 2 3 4 5 6 7 8 9 0

1 2 3 4 5 6 7 8 9 0

ANTIQUE EXTENDED No 120

24 POINT

4 A 8 a \$5 75

CHAMMOIS
Emigrating

18 POINT

6 A 12 a \$5 25

MEND
Ulsters

12 POINT

8 A 16 a \$3 95

RICHER
Brothers

10 POINT

12 A 24 a \$3 95

WARRING
Musketeers

8 POINT

12 A 24 a \$3 20

MANICURING
Hand Remedy

6 POINT

12 A 24 a \$2 50

INDIAN SABLES
Farm Hands Short
1234567890

5 POINT

18 A 36 a \$3 50

MOONLIGHT EXPOSE
Columbian Exposition Car
1234567890

ANTIQUE EXTENDED No 123

12 POINT

16 A \$2 35

MEDICINE **COMPOUND**

10 POINT

18 A \$2 05

CONFIDANTS

8 POINT

24 A \$2 25

ENCOURAGING

6 POINT

24 A \$1 90

GREAT PRODUCTS
1234567890

5 POINT

24 A \$1 65

RUSHING DOWN GRADES
1234567890

FRENCH ANTIQUE No 110

48 POINT

3 A 4 a \$8 25

ERIE Lines

42 POINT

4 A 5 a \$8 20

Annual FAIR

30 POINT

6 A 8 a \$4 60

STORE
Good Wine

36 POINT

4 A 6 a \$5 60

MEN
Honored

20 POINT

10 A 16 a \$3 00

SELECTED
Illustrated Art

18 POINT

10 A 16 a \$2 75

ACTRESS
Great Performance

10 POINT

20 A 38 a \$2 50

IMPORTED WARES
Bohemian Enameled Glasses

12 POINT

20 A 38 a \$3 25

CHOICE BOOKS
Publisher of Literature

8 POINT

30 A 60 a \$2 70

HANDSOME LITHOGRAPH
Landscape, Portrait and Diploma
1234567890

6 POINT

30 A 60 a \$2 60

LITHOGRAPHING STONE
Favorite Shade where Girls Promenade
1234567890

FRENCH CLARENDON EXTENDED No 120

42 POINT

3 A 5 a \$8 85

FOR**tu**ne

36 POINT

3 A 6 a \$6 00

BENZINE
Ornamental

30 POINT

4 A 8 a \$4 95

EXCURSION
Home Pledges

24 POINT

6 A 12 a \$5 05

MINDS
Theaters

18 POINT

8 A 16 a \$4 70

ROBBERS
Love Told

12 POINT

10 A 20 a \$3 45

MUSICIAN
Establishing

11 POINT

12 A 24 a \$3 50

DOMINIONS
Grand Rapids

10 POINT

16 A 32 a \$3 45

HONEY MOONS
Spanish Gunboats

8 POINT

18 A 36 a \$3 20

HUMANITY SAFE
Practically Established

6 POINT

18 A 36 a \$2 30

PERMANENT WEATHER
Seeds of Gratitude and Loves

5 POINT

20 A 40 a \$2 85

MODERN DUTIES SUSTAINED
Late Hours and Daily Worrying

FRENCH CLARENDON No 120

72 POINT

3 A 5 a \$14 15

MINE Shaft

60 POINT

3 A 6 a \$8 50

Lead REGION

48 POINT

4 A 8 a \$6 80

INDIAN Prisoners

36 POINT

6 A 12 a \$6 50

BIG Horn

30 POINT

8 A 16 a \$4 65

Morning RUN

24 POINT

12 A 24 a \$4 55

**INDUCEMENTS
Landscape Garden**

18 POINT

12 A 24 a \$3 00

**CHINESE INCURSION
Dramatic Conformation**

12 POINT

18 A 36 a \$2 90

**CLEVER PERFORMERS
Good American Products**

10 POINT

24 A 48 a \$2 65

**EXPERIMENTAL MERCHANT
Manufacturers Easily Controlled**

8 POINT

24 A 48 a \$2 30

**NEBRASKA PUBLISHING COMPANY
Atlantic and Grand Rapids Railway
1234567890**

6 POINT

32 A 64 a \$2 10

**CURIOSITIES FROM NORTHWESTERN COUNTRIES
Young Maidens Escape From Seminary Boarding House
1234567890**

EGYPTIAN EXTRA CONDENSED No 120

72 POINT

3 A 6 a \$8 70

Anarchist WRESTLES

60 POINT

4 A 8 a \$7 40

EUROPEANS Demonstrate

48 POINT

4 A 8 a \$5 20

Graduating SCHOLARS Prompted

42 POINT

8 A 16 a \$7 05

Auspiciously Decorated TURKISH BUILDINGS

36 POINT

8 A 16 a \$5 25

GEOGRAPHICAL SURVEYOR Contemplates Disturbance

24 POINT

12 A 24 a \$4 30

Newspaper Publishing Interesting FINANCIAL TELEGRAPHIC REPORTS

18 POINT

12 A 24 a \$2 80

DETERMINED POLICEMEN

Caught Notorious Burglars Plundering

1 2 3 4 5 6 7 8 9 0

12 POINT

16 A 32 a \$2 60

EXHAUSTED SOLDIERS RETURN

Numerous Hardships are Encountered Abroad

1 2 3 4 5 6 7 8 9 0

ANTIQUE POINTED No 120

48 POINT

3 A 5 a \$9 65

ONE Pint

42 POINT

3 A 6 a \$7 45

Nice FACES

36 POINT

4 A 8 a \$6 70

ROYAL Gown

30 POINT

5 A 10 a \$4 50

BEAUTIFUL BIRD
Historical Problems

24 POINT

6 A 12 a \$3 90

SPECULATION RIFE
Wilder Market Rumor

18 POINT

8 A 16 a \$3 85

WHUMPER
Heavy Stock
123456

12 POINT

10 A 20 a \$2 55

JOINT FOUND
Destroying Life
1234567

PART XI.

Gothics

PHILADELPHIA LINING GOTHIC

48 POINT NO 648

7 A 9 a \$6 50

MOTHERLY Inspirations

36 POINT NO 636

8 A 10 a \$5 50

Cosmopolitan SQUADRON

30 POINT NO 630

12 A 15 a \$5 00

ENTHUSIASTIC Parliamentarians

24 POINT NO 624

16 A 24 a \$4 50

Fascinating Exterior ORNAMENTATIONS

18 POINT NO 618

22 A 32 a \$4 25

CATECHUMEN
Educational Supremacy

14 POINT NO 614

30 A 42 a \$4 00

DELIBERATIONS
Great and Eloquent Orator

12 POINT NO 612

35 A 52 a \$3 75

BARTHOLDI STATUE
Liberty Enlightening the World

10 POINT NO 610

45 A 60 a \$3 50

PRINTERS DELIGHTED
Astonishing Typographic Inventions

8 POINT NO 608

52 A 70 a \$3 25

EQUINE SAGACITY OBSERVED
Modern Feline Trainer Electrifying Audience

6 POINT NO 606

60 A 70 a \$3 00

MAGNIFICENT BUILDING OPERATIONS
Great Schemes Receive Liberal Public Opitulation

1 2 3 4 5 6 7 8 9 0

1 2 3 4 5 6 7 8 9 0

All sizes align at top and bottom of face

PHILADELPHIA LINING GOTHIC

48 POINT NO 748

6 A 9 a \$7 50

REPORTS Believed

36 POINT NO 736

8 A 10 a \$6 50

Gorgeous EXHIBITION

30 POINT NO 730

10 A 15 a \$5 50

ANTIQUATED Construction

24 POINT NO 724

14 A 20 a \$4 75

Grand Operatic ENTERTAINMENT

18 POINT NO 718

18 A 28 a \$4 50

**DESTROYED
Western Entrance**

12 POINT NO 712

30 A 45 a \$4 00

**SUPERB LECTURE
Patronized by Juveniles**

8 POINT NO 708

45 A 60 a \$3 50

**GUARDIANS FRIGHTENED
Serious Results from Extravagance**

1 2 3 4 5 6 7 8 9 0

14 POINT NO 714

25 A 35 a \$4 25

**HANDSOMEST
Presents Exchanged**

10 POINT NO 710

35 A 50 a \$3 75

**PROUD SENTIMENT
Youths Declining Invitations**

6 POINT NO 706

50 A 60 a \$3 25

**INGENIOUS CONTRIVANCE
Plan to Avoid Detection During Absence**

1 2 3 4 5 6 7 8 9 0

PHILADELPHIA LINING GOTHIC

48 POINT NO 848

6 A 8 a \$8 50

PUBLIC Service

36 POINT NO 836

7 A 10 a \$7 00

National PROTEST

30 POINT NO 830

9 A 12 a \$6 00

SECTIONAL Grievances

24 POINT NO 824

14 A 20 a \$5 25

Emblematic CONTEMPLATION

18 POINT NO 818

16 A 26 a \$4 75

**STARLIGHT
Buxom Ramblers**

12 POINT NO 812

30 A 42 a \$4 25

**HARMONIOUS
Flowery Garden Spots**

8 POINT NO 808

45 A 60 a \$3 75

**MONETARY VALUES
Upholding the Credit of Nations
1 2 3 4 5 6 7 8 9 0**

14 POINT NO 814

25 A 35 a \$4 50

**KNOWLEDGE
Napoleonic Copyist**

10 POINT NO 810

35 A 50 a \$4 00

**CONSIDERATION
Golden Rules of Obeisance**

6 POINT NO 806

45 A 60 a \$3 50

**MISREPRESENTATION
Humanity is Susceptible to Blarney
1 2 3 4 5 6 7 8 9 0**

PHILADELPHIA LINING GOTHIC

48 POINT NO 948

5 A 7 a \$8 50

WAVE Depart

36 POINT NO 936

6 A 9 a \$7 00

Northern HOME

30 POINT NO 930

8 A 10 a \$6 00

PATRIOT Embarked

24 POINT NO 924

12 A 16 a \$5 25

Advertisement PRINTED

18 POINT NO 918

14 A 22 a \$4 75

PAINTED
Winter Scene

12 POINT NO 912

25 A 38 a \$4 25

REGIMENT
Mountain Fortress

8 POINT NO 908

38 A 50 a \$3 75

TRANSPORTATION
Declined by Foreign Visitor
1234567890

14 POINT NO 914

20 A 30 a \$4 50

MODERN
Design Admired

10 POINT NO 910

30 A 45 a \$4 00

REDUCTIONS
During Holiday Season

6 POINT NO 906

40 A 50 a \$3 50

COMPANIES ORGANIZED
Frolics Beneath a Starry Heaven
1234567890

PHILADELPHIA LINING GOTHIC

48 POINT NO 1048

4 A 6 a \$9 25

NICE Robes

36 POINT NO 1036

6 A 8 a \$7 75

Rapid DREAM

30 POINT NO 1030

7 A 10 a \$6 50

HONEST Games

24 POINT NO 1024

10 A 15 a \$5 50

Charming MUSICALE

18 POINT NO 1018

14 A 20 a \$5 00

**OBLIQUE
Short Lanes**

14 POINT NO 1014

18 A 26 a \$4 75

**PRECIOUS
Crown Jewels**

12 POINT NO 1012

22 A 30 a \$4 50

**PROVERBS
Forget Injustice**

10 POINT NO 1010

25 A 40 a \$4 25

**DEPICTING
Dramatic Elevation**

8 POINT NO 1008

35 A 45 a \$4 00

**CALIFORNIAN
Discovery of Gold Mines
1 2 3 4 5 6 7 8**

6 POINT NO 1006

38 A 50 a \$3 75

**NURSERY EDIBLES
Promoters of Epicureanism
1 2 3 4 5 6 7 8 9 0**

PHILADELPHIA LINING GOTHIC

48 POINT NO 1148

4 A 6 a \$10 00

RED Mask

36 POINT NO 1136

5 A 9 a \$8 50

Sound MIND

30 POINT NO 1130

7 A 10 a \$7 00

HOME Comfort

24 POINT NO 1124

10 A 15 a \$6 00

Ornament BROKEN

18 POINT NO 1118

12 A 18 a \$5 25

**DROVE
Tame Herd**

14 POINT NO 1114

16 A 26 a \$5 00

**CHANGE
Fickle Maids**

12 POINT NO 1112

20 A 32 a \$4 75

**BATHERS
Heated Season**

10 POINT NO 1110

25 A 40 a \$4 50

**FORTUNATE
Reporter Engaged**

8 POINT NO 1108

35 A 45 a \$4 25

**CELEBRATION
Gathering of Speakers
12345678**

6 POINT NO 1106

35 A 50 a \$4 00

**GENTLE EXERCISE
Developing the Youngster
1234567890**

PHILADELPHIA LINING GOTHIC

48 POINT No 1248

4 A 5 a \$9 25

DIN Heard

36 POINT No 1236

5 A 7 a \$7 75

Noted MEN

30 POINT No 1230

6 A 9 a \$6 50

SHOE Marked

24 POINT No 1224

9 A 12 a \$5 50

Damaged BENCH

18 POINT No 1218

12 A 15 a \$5 00

MATCH
Burn Cord

12 POINT No 1212

18 A 28 a \$4 50

NOISOME
Martial Sound

8 POINT No 1208

28 A 42 a \$4 00

INSTRUCTIONS
Educated Mechanics
1 2 3 4 5 6 7 8

14 POINT No 1214

14 A 22 a \$4 75

MUSING
Comic Song

10 POINT No 1210

22 A 35 a \$4 25

REPORTS
Sporting Writers

6 POINT No 1206

30 A 45 a \$3 75

CONGREGATION
Delighted with Sermons
1 2 3 4 5 6 7 8 9 0

PHILADELPHIA LINING GOTHIC

48 POINT NO 1348

3 A 4 a \$10 00

SIX Bats

36 POINT NO 1336

4 A 6 a \$8 50

New SITE

30 POINT NO 1330

6 A 8 a \$7 00

MAY Parties

24 POINT NO 1324

7 A 12 a \$6 00

Electric SHOCK

18 POINT NO 1318

10 A 14 a \$5 25

**GLIDE
Fast Tide**

14 POINT NO 1314

14 A 22 a \$5 00

**STRING
Lyric Poet**

12 POINT NO 1312

18 A 28 a \$4 75

**BALSAM
Doctor Right**

10 POINT NO 1310

20 A 35 a \$4 50

**PARKSIDE
Natural Scenes**

8 POINT NO 1308

25 A 40 a \$4 25

**BIOGRAPHER
Historical Writings
123456789**

6 POINT NO 1306

28 A 40 a \$4 00

**FASCINATION
Prodigious Magicians
123456789**

PHILADELPHIA LINING GOTHIC

48 POINT NO 1448

3 A 5 a \$11 25

NO Rain

36 POINT NO 1436

5 A 7 a \$9 75

Mark VAT

30 POINT NO 1430

6 A 9 a \$8 25

TAKE Pains

24 POINT NO 1424

9 A 12 a \$7 00

Steam WATCH

18 POINT NO 1418

12 A 15 a \$6 00

**PAST
Fine Site**

14 POINT NO 1414

15 A 22 a \$5 50

**WORN
Gold Rope**

12 POINT NO 1412

16 A 26 a \$5 00

**DEPART
Slow Trains**

10 POINT NO 1410

22 A 32 a \$4 75

**PARDON
Honest People**

8 POINT NO 1408

25 A 40 a \$4 50

**DESIRABLE
Beautiful Designs
1234567**

6 POINT NO 1406

28 A 45 a \$4 25

**GUARDSMEN
Exhausted Regiment
12345678**

LINING GOTHIC EXTENDED No 40

36 POINT

4 A 6 a \$7 10

FAST Race

30 POINT

5 A 7 a \$5 15

Beau MONDE

24 POINT

7 A 10 a \$4 50

**HARTFORD
Pleasure Steamer**

18 POINT

10 A 14 a \$4 30

**FAMILY GROUPS
Basking in Sunbeams**

14 POINT

12 A 18 a \$3 50

**MODERN SAYINGS
Phonographs Recharged**

12 POINT

14 A 22 a \$3 40

**DEMANDS
Money Loans**

10 POINT

16 A 24 a \$3 10

**MONARCHS
Create Blunders**

8 POINT

20 A 30 a \$3 00

**TEARQUICK
Fashionable Gaskins
1 2 3 4 5 6 7**

6 POINT

25 A 35 a \$3 00

**PREDETERMINE
Eager Bargain Hunters
1 2 3 4 5 6 7 8**

LINING GOTHIC SERIES

36 POINT NO 43

6 A 9 a \$7 10

FATAL Combats

30 POINT NO 43

8 A 12 a \$6 60

Headmost BEAUS

24 POINT NO 43

10 A 15 a \$5 20

MODERN Homestead

18 POINT NO 43

14 A 25 a \$4 95

CRUISE
Ocean Waves

12 POINT NO 43

25 A 40 a \$4 20

INGENIOUS
Automatic Machine

10 POINT NO 43

36 A 50 a \$4 10

UNCOMBINED
Improved Roofing Material

8 POINT NO 43

36 A 55 a \$3 90

ADVANCEMENT
Sunshine of Prosperous Days

6 POINT NO 417

60 A 70 a \$4 00

CELESTIAL HEMISPHERE
Inclinations of Base with the Horizon
Adjacent Angles and Distances

6 POINT NO 416 C and 1 c

60 A 70 a \$3 70

MICROSCOPIC INDICATIONS
Calculations made by Illustrious Astronomers
Changes in Atmospheric Strata

6 POINT NO 415

60 A \$2 25

INACCURATE GEODETIC OPERATIONS
DOUBTFUL CIRCUMFERENCE OF THE TERRESTRIAL SPHERE
CONSIDERED BY EXPERT MATHEMATICIANS

6 POINT NO 414

60 A \$2 25

TRIANGULATION OF THE MERIDIAN
SUPERIORITY OF THE MODERN INSTRUMENTS FOR MEASUREMENT
IMPROVED METHODS AND APPLIANCES ADOPTED

LINING GOTHIC SERIES

36 POINT NO 44

6 A 8 a \$7 65

STATE Burden

30 POINT NO 44

8 A 12 a \$8 95

Mounted SHEIKS

24 POINT NO 44

10 A 15 a \$5 65

TRAINED Elephants

18 POINT NO 44

14 A 22 a \$4 75

Emancipated PATAGONIAN

12 POINT NO 44

22 A 40 a \$4 10

ASCENDING
Beautiful Pathways

10 POINT NO 44

28 A 45 a \$4 05

TOURISTS
Discover Ancient Ruins

8 POINT NO 44

36 A 55 a \$3 80

RECONSTRUCTING
Stringent Fireside Regulation

6 POINT NO 422

50 A 70 a \$4 45

SOCIAL GATHERINGS
Harmony and Sunshine Displayed

6 POINT NO 421

50 A \$2 35

GENDARMES SUMMONED
LIGHTFINGER'S BRIGANDS TAKEN

6 POINT NO 420

50 A \$1 70

MOONSTRUCK BURGLARS
SLEIGHS BROUGHT INTO REQUISITION

6 POINT NO 419

50 A \$1 40

POLICEMEN HUNTING INVADERS
ANGRY HOUSEWIFE OVERHAULING BUREAUS

6 POINT NO 418

50 A \$1 35

CARELESS BOLTING OF FRONT DOORS
RECOMMENDED BY PROFESSOR LIGHTFINGER

LINING GOTHIC SERIES

36 POINT No 45

4 A 7 a \$6 80

FINE Singers

30 POINT No 45

6 A 9 a \$6 35

Morning DAWN

24 POINT No 45

8 A 12 a \$5 20

HEROIC Adventure

18 POINT No 45

12 A, 18 a \$4 45

Roving FOREIGN Waters

12 POINT No 45

20 A 30 a \$4 00

**GRECIAN
Damsels Adopted**

10 POINT No 45

25 A 45 a \$4 25

**HUNTSMEN
Spinning Fishing Yarns**

8 POINT No 45

36 A 55 a \$3 80

**ROYSTERING
Juveniles Charm and Delight**

6 POINT No 427

45 A 70 a \$4 45

**LIBERAL PENSION
Decrepit Old Ringsters Disturbed**

6 POINT No 426

45 A \$2 10

**MASTERLY RETREAT
STRUGGLES AGAINST DESTINY**

6 POINT No 425

45 A \$1 90

**SCENES AND INCIDENTS
DINNER-TIME AMONG INSURGENTS**

6 POINT No 424

45 A \$1 55

**BOILING GEYSER WATER
ABANDONMENT OF FUEL FOR STEAM-POWER**

1 2 3 4 5 6 7 8 9 0

6 POINT No 423

45 A \$1 45

**RESOLUTIONS ON WARFARE
ARMIES MUST NOT EXCEED FOUR HUNDRED MEN**

1 2 3 4 5 6 7 8 9 0

INTERCHANGEABLE GOTHIC

48 POINT

3 A \$5 90

MINORS

36 POINT

4 A \$3 90

CONJURED

32 POINT

4 A \$3 00

HARBORING

24 POINT

6 A \$2 45

UNITED MARINE

20 POINT

8 A \$2 50

GROUND

18 POINT

12 A \$2 30

MONITORS

12 POINT

18 A \$2 00

BATTLE FIELDS

10 POINT

18 A \$1 35

COLD ATMOSPHERE

8 POINT

24 A \$1 35

REMEMBER OUR HEROES
SOLDIERS COMING HOME

6 POINT NO 5

36 A \$1 70

IMMENSE FARM PROPERTIES
GOOD NEWSPAPER REPORTS

6 POINT NO 4

36 A \$1 45

EMBRACES OF AFRICAN GORILLAS
ARE STRUGGLING AGAINST POWER

6 POINT NO 3

36 A \$1 25

BREAKFAST TIME AMONG INSURGENTS
HORRORS DURING FRENCH REVOLUTION

6 POINT NO 2

36 A \$1 05

YELLOWSTONE GEYSER WATER CORPORATION
ANGRY HOUSEWIVES OVERHAULING BUREAUS
1 2 3 4 5 6 7 8 9 0

6 POINT NO 1

36 A \$0 90

INTERNATIONAL CONGRESS ON FUTURE WARFARES
NOT TO EXCEED OVER ONE HUNDRED THOUSAND MEN
1 2 3 4 5 6 7 8 9 0

5 sizes on 6-Point body, \$6.00

Complete series, 14 sizes, \$30.00

All sizes line at the bottom. 12 to 48 Point line at both top and bottom

COMBINATION GOTHIC

12 POINT No 159

16 A \$1 50

MAGNIFICENT SACRED PANORAMIC EXHIBITS

12 POINT No 158

16 A \$1 50

BARNSTORMING
BREAKING CONTRACT

12 POINT No 157

18 A \$1 25

ORDERING WARSHIPS
STRONG VETERANS MARCH

12 POINT No 156

24 A \$1 25

MERCHANTS COMPLAIN
BANKING FAILURES REPORTED

6 POINT No 155

32 A \$1 50

TROUBLESOME MACHINERY
MECHANICAL DISCOVERY DOUBTED

6 POINT No 154

42 A \$1 50

UNVEILING FRANKLIN STATUE
THOUSANDS ATTEND THE OPENING SERVICE

6 POINT No 153

42 A \$1 50

WEALTHIEST AMERICAN ENTERPRISE
EXPORTING VARIOUS ARTICLES MANUFACTURED

6 POINT No 152

50 A \$1 25

WONDERFUL AUSTRALIAN ACROBATIC PERFORMER
ASTONISHING FEAT BROUGHT FORTH THUNDERING APPLAUSE

1 2 3 4 5 6 7 8 9 0

6 POINT No 151

55 A \$1 25

GERMAN SINGING VEREINS ENJOYING DRAMAS
OKLAHOMA COWBOY DESPERADO RELIEVING NUMEROUS PASSENGERS

1 2 3 4 5 6 7 8 9 0

COMBINATION CONDENSED GOTHIC

12 POINT No 166

16 A \$1 50

RESIDENTS ANTICIPATING THE FORMATION OF YACHTING ORGANIZATIONS

12 POINT No 165

18 A \$1 25

SERENADERS WERE GATHERING NEAR THE HOUSE WHEN THE COLONELS RESPOND

12 POINT No 164

24 A \$1 25

LECTURING UNDER DIFFICULTIES
SPEAKERS HOARSE AND AUDIENCE FROZEN

6 POINT No 163

32 A \$1 50

COURAGEOUS COMPOSITOR TRAMPERS
SEVERAL DELIGHTFUL MEDICAL DISCOVERIES PERFORMED

6 POINT No 162

40 A \$1 25

SCHEDULED RAILROAD TRAINS WRECKED
DELAYING FOREIGN FREIGHT NEARLY TWELVE MONTHS

1 2 3 4 5 6 7 8 9 0

6 POINT No 161

50 A \$1 25

MOUNTAIN CLIMBING GREATLY ENJOYED
SOUTHERN CLIMATE SOUGHT DURING SEVERE COLD WEATHER

1 2 3 4 5 6 7 8 9 0

GOTHIC CONDENSED No 112

24 POINT

12 A 20 a \$3 75

BROTHER DANCES Blackface Specialties

18 POINT

16 A 24 a \$3 20

Unexpected Combination BROUGHT BRACKETS

12 POINT

24 A 36 a \$3 08

BREAKERS LOWERING WHALING CREWS
Thornton Anniversary Receptions and Operatic Entertainments

10 POINT

28 A 44 a \$2 50

SHOPLIFTER SELECTING
Watches and Precious Stones Taken
1 2 3 4 5 6 7 8 9 0

8 POINT

40 A 62 a \$2 70

RENOWNED LITERARY PERSON
Prominent Writers Hesitate Sending Articles
Dreading Instantaneous Remittances
1 2 3 4 5 6 7 8 9 0

JOHNSTON GOTHIC

16 POINT

16 A 24 a \$4 00

GENTEEL MEN ESTABLISHED
Automatic Millionaire Purchasing Securities

14 POINT

14 A 36 a \$3 75

STIRRING POLITICAL SPEECHES
Wonderous Adventures in King Solomon's Mines

12 POINT

15 A 40 a \$3 50

SERIES FURNISHED
Cheaper Refreshment Ticket

10 POINT

18 A 45 a \$3 00

MAGNIFICENT YACHT
Trained Animals for Performances

8 POINT

20 A 50 a \$2 50

NUMEROUS REQUESTS
Beautiful Productions from Flowers
1 2 3 4 5 6 7 8 9 0

6 POINT

24 A 60 a \$2 25

COMMERCIAL ADVERTISER
Unavoidable and Laughable Adventures
1 2 3 4 5 6 7 8 9 0

COMBINATION GOTHIC F

24 POINT No 1528 8 A \$3 00

BADGES

18 POINT No 1526 12 A \$2 50

SHOUTING

12 POINT No 1524 20 A \$2 25

REFRESHMENT

12 POINT No 1522 24 A \$2 25

JUBILANT SOLDIERS

6 POINT No 1533 40 A \$2 00

CROWDED RAILROAD TRAINS

6 POINT No 1531 42 A \$1 60

INDUSTRIAL ESTABLISHMENTS CLOSED

6 POINT No 1529

45 A \$1 40

12345 MAGNIFICENT SHOWING OF THE REGULAR TROOPS 67890

24 POINT No 1527 8 A \$3 00

TRIUMPH

18 POINT No 1525 14 A \$2 40

CONDUCTORS

12 POINT No 1523 24 A \$2 25

MILITARY PARADES

12 POINT No 1521 30 A \$2 25

PUBLIC ENTERTAINMENT

6 POINT No 1532 40 A \$1 75

DISTINGUISHED GUARDS IN LINE

6 POINT No 1530 45 A \$1 50

HEROES OF NUMEROUS FIERCE ENGAGEMENTS

TELESCOPIC GOTHIC F

6 POINT No 158 30 A \$2 00

PUNISHMENT FOR CRIMINALS

6 POINT No 156 30 A \$1 15

LENIENT JUDGE RELEASED THE PRISONER 213

6 POINT No 157 30 A \$1 60

HABEAS CORPUS PROCEEDING BEGAN

6 POINT No 155 30 A \$1 00

GREAT INTEREST MANIFESTED BY PRETTY SPECTATORS 456

IMPRINT GOTHIC E-F

6 POINT No 121 32 A \$0 75

IRATE HUSBANDS DENOUNCE THE PROPOSED FEMALE SUFFRAGE

6 POINT No 150 48 A \$0 75

STRONG RESOLUTIONS UNANIMOUSLY ADOPTED AT THE HENPECK ASSOCIATION MEETINGS

6 POINT No 124

28 A \$0 65

12345 DEMANDING THE RIGHT OF CARRYING LATCH KEYS IN DAY TIME 67890

COPPER ALLOY IMPRINTS F

Cast in one piece, any of the faces here shown, at the following prices:

*100 OF ANY ONE KIND FOR \$8 00 NET

50 OF ANY ONE KIND FOR \$5 00 NET

STYLE 1
EXCELSIOR PRINTING CO., DENVER

STYLE 2
PRESS OF STYLES & CASH, NEW LONDON

STYLE 3
NEVERSLEEP BOOK AND JOB PRINTING CO., WAKEFORD, OHIO

STYLE 4
FITLER JOB PRINTING COMPANY

STYLE 5
STANDARD PRINTING & BINDING CO., CHICAGO

STYLE 6
LEDGER PRINT, FRANKLIN

STYLE 7
SUNSHINE PUBLISHING HOUSE, CANTON

STYLE 8
DIXON, PRINTER AND STATIONER

We can furnish Electrotype Imprints of above styles, but recommend the Copper Alloy, as they have a uniform clearness of face not obtainable in so small an electro line. The Copper Alloy are much cheaper, as 50 of any one style cost no more than 17 of the Electrotype Imprint.

Electrotype Imprints, each, net \$0 30

** If Imprints are wanted longer than one and one-fourth inches in length, they will have to be made in two or more pieces, and \$3.00 extra per hundred will be charged for each extra piece.*

OCTIC No 1

OCTIC No 2

48 POINT 4 A \$6 35

FIRE

42 POINT 4 A \$4 40

COST

36 POINT 5 A \$4 40

CHOIR

30 POINT 6 A \$3 00

BRIDGE

24 POINT 8 A \$3 00

PAINTER

20 POINT 8 A \$2 30

REPORTER

16 POINT 15 A \$2 00

PAINT BRUSH

12 POINT 20 A \$2 00

SANDY GROUND

10 POINT 20 A \$1 45

TOBACCO GROWERS

8 POINT 30 A \$2 00

WAGON MANUFACTURE

6 POINT 30 A \$1 50

FINE MOROCCO BOUND BOOKS

1234567890

42 POINT 4 A \$4 25

ROBE

36 POINT 5 A \$3 80

MIGHT

30 POINT 6 A \$3 20

CRIMES

24 POINT 8 A \$2 95

POINTER

20 POINT 8 A \$2 30

PREMISES

18 POINT 12 A \$2 25

RARE BIRDS

16 POINT 15 A \$2 40

CUBAN HOME

12 POINT 20 A \$2 10

PURE BOURBON

10 POINT 30 A \$2 00

RICHWOOD TIMBER

8 POINT 30 A \$1 95

EIGHT CORNER QUADS

6 POINT 30 A \$1 60

SOUTHERN FRUIT GROWER

1234567890

GOTHIC CONDENSED No 37

72 POINT

4 A \$8 20 4 A 6 a \$14 15

MEN Count

60 POINT

5 A \$6 50 5 A 6 a \$10 80

Rulers HUNT

48 POINT

6 A \$5 55 6 A 10 a \$9 75

BIG Job

42 POINT

6 A \$4 00 6 A 10 a \$6 90

NO Home

36 POINT

8 A \$3 75 8 A 12 a \$6 55

**TOSSED
White Seas**

30 POINT

10 A \$2 95 10 A 15 a \$5 35

**WRECKED
Sunk or Lost**

24 POINT

12 A \$2 50 12 A 8 A 20 a \$5 35

**IMPRISONED
BURNT Demented**

18 POINT

15 A \$1 95 15 A 10 A 25 a \$4 20

**APPROPRIATION
INTRODUCES Disasters**

12 POINT

20 A \$1 40 20 A 12 A 30 a \$3 00

**DESPERATE UNREST
DEVITALIZES Developments
1234567890**

10 POINT

25 A \$1 35 25 A 20 A 40 a \$3 15

**UNCONSIDERED ASSERTIONS
VOLUNTEERED Without Conditions
1234567890**

GOTHIC CONDENSED No 122

72 POINT

3 A \$4 25 3 A 6 a \$10 85

RIFLE TO Send

60 POINT

3 A \$2 90 3 A 6 a \$7 70

Silver BOX TRADE

48 POINT

5 A \$2 65 4 A 8 a \$6 10

Big House

42 POINT

5 A \$2 05 6 A 12 a \$5 90

HARD Bread

36 POINT

5 A \$1 45 8 A 16 a \$6 40

**PURE MAIDS
GOLDEN Ideas**

24 POINT

6 A \$1 05 10 A 20 a \$3 85

**REFORM POLICE
EXCURSION Rates**

20 POINT

8 A \$1 00 10 A 20 a \$3 10

**DUTCH NAVIGATOR
PENSION Directories**

18 POINT

8 A \$0 70 12 A 24 a \$2 80

**HOMeward JOURNEY
SOLDIERS Lead Patriotic**

12 POINT

10 A \$0 50 18 A 36 a \$2 30

**ENGLISH OPERA PERFORMER
INHABITANT OF NEWFOUNDLAND
When the Sparrows Homeward**

10 POINT

20 A 40 a \$1 75

**OBSERVE THE CYCLONE WHIRLWIND
Christmas Games and Well-Filled Larder
Toothsome Delicacies Devoured 234567**

GOTHIC CONDENSED No 129

* 72 POINT

4 A 6 a \$11 50

HONEST Bears

* 60 POINT

4 A 6 a \$8 50

Favors DIAMOND

48 POINT

6 A 10 a \$6 35

GOLD Fish

42 POINT

10 A 12 a \$5 90

Good HORSE

36 POINT

10 A 12 a \$4 60

**HOUSEHOLDS
Copper Button**

24 POINT

15 A 20 a \$4 00

**ILLINOIS MINERS
Traveling Tourists**

20 POINT

15 A 20 a \$2 65

**GRAND MASQUERADE
Moonlight Promenading**

18 POINT

15 A 25 a \$2 10

**MECHANICAL DECORATION
Combinations of Machinery**

12 POINT

20 A 30 a \$1 85

**FINE MODERN FRESCO PAINTINGS
Regular Excursion to South Africa**

* 10 POINT

20 A 40 a \$1 75

**GOVERNMENT TELEGRAPH OWNERSHIP
Dark Inhabitants of Southern Plantations**

1234567890

1234567890

GOTHIC No 122

48 POINT

5 A \$5 45 3 A 6 a \$9 25

HOME Ties

42 POINT

4 A \$3 40 4 A 8 a \$8 00

Clam BAKES

36 POINT

5 A \$3 10 4 A 8 a \$6 60

HORSE Taming

30 POINT

6 A \$2 55 5 A 10 a \$5 35

ARE Nearer HOME

24 POINT

8 A \$1 85 8 A 16 a \$5 35

**HUMORS
BAD Paste**

18 POINT

10 A \$1 25 10 A 20 a \$3 15

**ARTIST PAINT
NATURE Fresh**

10 POINT

18 A \$1 15 18 A 36 a \$3 15

**HOLIDAY PRESENT
Countersigned NOTES**

6 POINT

24 A \$0 90 24 A 48 a \$2 65

**PREACH TOUCHING SERMONS
Congregation Praise DISCOURSE
1234567890**

20 POINT

10 A \$1 70 10 A 20 a \$4 90

**CONQUERS
SURE Winner**

12 POINT

16 A \$1 20 16 A 32 a \$3 65

**GOLD HUNTING
KLONDIKE Mining**

8 POINT

24 A \$1 10 24 A 48 a \$3 45

**WONDERFUL MACHINE
FLYING Through the Skies**

5 POINT

24 A 48 a \$2 90

**PATENT CYLINDER PRINTING PRESS
Most Beautiful, Glorious and Charming
1234567890**

MID-GOTHIC SERIES

72 POINT

3 A 4 a \$14 00

LOST Run

60 POINT

3 A 4 a \$10 00

Hand GONE

54 POINT

3 A 5 a \$8 00

FRIGID Blast

48 POINT

4 A 6 a \$7 25

**CHAMPIONS
Undiscouraged**

42 POINT

5 A 8 a \$6 50

**DELIGHTFUL
Mountain Resorts**

MID-GOTHIC SERIES

36 POINT

6 A 9 a \$5 00

LAUDABLE ACT
Saved Drowning Man

30 POINT

7 A 10 a \$4 25

CALIFORNIAN MINERS
Expect Fabulous Returns

24 POINT

9 A 12 a \$4 00

DESERVES PUNISHMENT
Overtakes Audacious Lynchers

18 POINT

12 A 16 a \$3 50

MISREPRESENTED CONSTITUENTS
Popular Sentiment Favors Investigation

14 POINT

12 A 18 a \$3 25

AMUSEMENT FROM ELECTRICAL DEVICES
Latest Juvenile Toys Unite Science with Pleasure

12 POINT

16 A 20 a \$3 00

WESTERN METROPOLIS
Honors Returning Delegation

10 POINT

20 A 26 a \$2 75

MAGNIFICENT GATHERINGS
Celebrated Etymological Authorities

8 POINT

22 A 30 a \$2 50

JOYOUS CHRISTMAS HOLIDAYS
Extensive Arrangements for Good Children
12 3 4 5 6 7 8 9 0

6 POINT

24 A 38 a \$2 25

RARE BARGAINS IN ANTIQUE FURNITURE
Large Collections of Imported Tables and Wardrobes
12 3 4 5 6 7 8 9 0

— c —

ROUND GOTHIC

60 POINT

5 A 8 a \$12 30

MINE Hunters

48 POINT

7 A 10 a \$11 70

General DEPOTS

36 POINT

10 A 14 a \$7 70

AUTUMN Amusements

30 POINT

12 A 18 a \$6 70

Enlarged Harbor DREDGING

24 POINT

14 A 20 a \$5 50

Theatre BURNS

22 POINT

18 A 24 a \$5 15

Practical TRADER

18 POINT

18 A 28 a \$3 80

EARNEST Legislature

14 POINT

22 A 42 a \$3 70

PASTORAL Requirements

12 POINT

22 A 42 a \$3 05

Recollections of MERRIMENT

11 POINT

36 A 52 a \$3 15

Crimson Muslin and DECORATIONS

10 POINT

36 A 52 a \$2 75

INVESTIGATING Committee on Finance

8 POINT

36 A 70 a \$2 85

SCAVENGER FOUND Working before Supper

7 POINT

36 A 70 a \$2 65

Empty Pocket Filled by BENEFIT ASSOCIATION

6 POINT

52 A 70 a \$2 70

Improved Dress Styles Sold on REASONABLE TERMS

1234567890

1234567890

ROYAL GOTHIC

48 POINT

4 A 8 a \$8 95

LIGHT Return

36 POINT

5 A 10 a \$7 05

Meteor SECOND

30 POINT

6 A 12 a \$5 25

**EXCURSION NORTH
Round Trip Tickets**

24 POINT

8 A 16 a \$5 05

**BOHEMIAN RETURNED
Resignations Tendered**

20 POINT

10 A 20 a \$4 80

**CHRISTMAS
Santa Claus**

18 POINT

10 A 20 a \$3 15

**GREAT POLICE
Serving County**

12 POINT

16 A 32 a \$3 15

**MODERN RAILROAD
Splendid For Travel**

10 POINT

18 A 36 a \$2 70

**DISPOSING OF STOCKS
Big Inducement Offered**

8 POINT

24 A 48 a \$3 05

**FIRST DIVIDEND RECEIVED
Money Used for Church Debt
1234567890**

6 POINT

24 A 48 a \$2 25

**BRIGHT AMERICAN COMEDIANS
Relating Their Exciting Adventures
1234567890**

GOTHIC CONDENSED No 128

* 60 POINT

7 A \$7 35

SCENIC FOREST

48 POINT

4 A \$3 55

GOOD PROPERTY

42 POINT

5 A \$2 80

HUNTER MOUNTED

36 POINT

8 A \$3 10

REWARDING SOLDIERS

30 POINT

10 A \$2 65

POPULATION

24 POINT

12 A \$2 25

HUMAN HANDS

20 POINT

16 A \$2 45

DENTAL PARLOR

18 POINT

18 A \$2 10

MIDNIGHT VISITORS

16 POINT

24 A \$2 10

INDEPENDENT FARMER

12 POINT

32 A \$2 10

PRETTY MAIDEN SMILES

10 POINT

36 A \$1 70

MANUFACTURING NEAT BORDER

8 POINT

42 A \$1 65

SEVERAL EXPERIENCED TRADESMEN

6 POINT

48 A \$1 55

PRESENTED FOR IMMEDIATE CONSIDERATION

5 POINT ON 6 POINT

56 A \$1 45

YOUNG CHILDREN ADMITTED TO AFTERNOON SCHOOLS

GOTHIC CONDENSED No 127

48 POINT

4 A \$3 00

MADISON RECORDER

42 POINT

5 A \$2 40

HUNTERS 56 MOUNTED

36 POINT

8 A \$2 45

DENVERS SQUARE GARDENS

30 POINT

10 A \$2 30

MATHEMATICS

24 POINT

12 A \$2 15

DEMONSTRATIVE

20 POINT

16 A \$2 10

DENTAL 45 PARLOR

18 POINT

18 A \$1 90

HUMANE 68 BELOVED

16 POINT

24 A \$1 95

POPULATION INCREASING

12 POINT

32 A \$1 80

BEAUTIFUL FLOWER GARDENS

10 POINT

36 A \$1 40

NUMEROUS EXPERIENCED TRADESMEN
REPORTED 546 SWINDLED

8 POINT

42 A \$1 35

BRIBERY CHARGES CONCERNING PROMINENT
GOVERNMENT 45678 OFFICIALS

6 POINT

48 A \$1 25

KNOWING THAT THE HUMAN HAND IF INTELLIGENTLY
EDUCATED AND SKILLFULLY EMPLOYED

5 POINT ON 6 POINT

56 A \$1 30

THIS INTELLIGENT COMBINATION OF RECENT IMPROVEMENTS
PRESENTED FOR FURTHER CONSIDERATION

CHAMFER CONDENSED

96 POINT

5 A \$12 80

ENCOURAGED

84 POINT

5 A \$10 30

SHIPWRECKED

72 POINT

7 A \$9 90

RECENT DECISION

60 POINT

7 A \$7 15

CAVALIER ADVANCED

48 POINT

7 A \$6 15

PROMOTER

42 POINT

10 A \$4 90

PRESUMPTIVE

CHAMFER CONDENSED

36 POINT 10 A \$3 75

GARDEN HOMES

24 POINT 18 A \$3 00

REMEDIES FOR CHOLERA

12 POINT 36 A \$2 60

CAREFUL HABITS AND GOOD INTENTION

8 POINT 45 A \$2 00

WESTERN HEMISPHERE EXPLORED BY NOTED STUDENTS

1 2 3 4 5 6 7 8 9 0

30 POINT 14 A \$4 00

THREE PRECINCTS

18 POINT 30 A \$3 60

BARGAIN SALE OF FINE CHINA

10 POINT 36 A \$2 00

HEROIC SACRIFICES MADE BY A YOUNG WOMAN

6 POINT 52 A \$2 00

HANDSOME ENGRAVINGS DRAWN BY SOME OF THE LEADING ARTISTS

1 2 3 4 5 6 7 8 9 0

GOTHIC EXTRA CONDENSED No 150

48 POINT A 5 A 8 a \$5 00

RENUMBERED Antiquated Houses

42 POINT A 6 A 9 a \$4 50

Musicians Gave NOVEL EXHIBITION

30 POINT 10 A 16 a \$4 50

DEMAND Satisfaction

18 POINT 18 A 24 a \$3 25

Contest of Noted STRONG MEN

10 POINT 20 A 38 a \$2 75

ADVANCE GUARD MEETS With Some Resistance

1 2 3 4 5 6 7 8 9 0

24 POINT 12 A 18 a \$3 50

RENOMINATE County Clerk

12 POINT 20 A 40 a \$3 00

Election Returns Read FROM THE STAGE

8 POINT 22 A 32 a \$2 50

PROMINENT MERCHANTS Arranging Monthly Expositions

1 2 3 4 5 6 7 8 9 0

GOTHIC No 123

48 POINT

4 A 8 a \$9 00

GREAT HEAD
Morning Walk

36 POINT

5 A 10 a \$7 05

GOLDEN CHAIN
Beautiful Present

30 POINT

6 A 12 a \$6 25

JOYFUL VOICES RISE
Far Over the Mountain

24 POINT

10 A 20 a \$4 75

NEVER FAILS
Big Fish Story

18 POINT

12 A 24 a \$3 80

STEAM CHURN
Farmers Delight

12 POINT

18 A 36 a \$3 40

HONEST AND TRUE
Over the Garden Wall

10 POINT

20 A 40 a \$2 65

HANDSOME STRUCTURE
Beautiful American Temples

8 POINT

24 A 48 a \$2 50

SWEEPING HURRICANE DECKS
Then this Poor Man Began to Think

6 POINT

32 A 64 a \$2 60

FASHIONABLE STREET PROMENADINGS
Our Brightest Hopes are the Most Fleeting

1234567890

1234567890

GOTHIC No 125

48 POINT

4 A 8 a \$9 30

HORSE brain

42 POINT

4 A 8 a \$7 10

Railroad UNION

36 POINT

6 A 12 a \$7 10

**UNITED POWERS
Adopt Golden Rule**

30 POINT

8 A 16 a \$5 20

**INDUSTRY
Heavy Purse**

24 POINT

10 A 20 a \$4 35

**SILVER MINE
Fine Diamonds**

18 POINT

12 A 24 a \$3 80

**SPANISH MAKE
Cuban Departing**

14 POINT

16 A 32 a \$2 80

**HANDSOME AND GAY
Heiress of Paradise Alley**

12 POINT

18 A 36 a \$2 50

**JUMPING OVER DITCHES
Lively Dime Museum Freaks**

10 POINT

24 A 48 a \$2 65

**GREAT ANNUAL HORSE SALE
Blue Ribbon Parade Of Animals**

8 POINT

24 A 48 a \$2 30

**PREACHING TOUCHING SERMONS
Congregation Praising the Discourses**

6 POINT

32 A 64 a \$2 45

**HARVESTING THROUGH THE COUNTRIES
Farmers Employing all the Available Hands**

1234567890

1234567890

GOTHIC CONDENSED No 123

36 POINT

6 A 12 a \$5 90

HANDSOME BUILDINGS
Credit Renowned Architect

30 POINT

10 A 20 a \$4 90

DIAMOND COMBINE EXPOSED
Australian Mines Seem to Prosper

24 POINT

12 A 24 a \$4 00

FARM MACHINERY IN GREAT DEMAND
For Cuba Porto Rico Manila and Honolulu

18 POINT

12 A 24 a \$2 95

EVENING ROAMINGS
Will Conduce Slumber

12 POINT

18 A 36 a \$2 55

INTERNATIONAL MUSEUMS
Travelers Compliment Them
See That They Are Plentiful
1234567890

8 POINT

32 A 64 a \$2 80

BELEAGUERED WAYFARERS DESTITUTE
Discomforts of Sojourning in Darkest Africa
Thrilling Experience of Seven Englishmen
The Upper Congo is a Terror to White Men
Everything Succumbs Under Tropical Heat
1234567890

14 POINT

18 A 36 a \$3 15

STRONG WINTER GALES
Decks Swept by Hurricane

10 POINT

24 A 48 a \$2 55

SHARPSHOOTERS TOURNAMENT
Professional Marksmen Are Adepts
Autumn Brings Sport to the Hunter
1234567890

6 POINT

32 A 64 a \$2 35

ROMANTIC MOUNTAIN AND VALLEY SCENERY
Amateur Athletes Climbing Aloft to the Pinnacle
Sunshine Carries Happiness to the Woodsman
Bland Nature Smiles on Winding Forest Streams
Cloudbursts Are Frequent in all Lofty Locations
1234567890

GOTHIC CONDENSED No 124

48 POINT

4 A 8 a \$6 40

Tortures **ENDURED**

42 POINT

4 A 8 a \$5 05

SURGICAL Instruments

36 POINT

6 A 12 a \$5 50

MAGNIFICENT PRODUCTION
Commendable Newspapers

30 POINT

8 a 16 a \$4 35

UNPRECEDENTED ATTRACTION
Thirteenth Industrial Exposition

24 POINT

12 A 24 a \$4 45

INDESTRUCTIBLE
Coast Fortification

12 POINT

18 A 36 a \$2 65

REQUIRED SATISFACTION
Standard Schemes Adopted

8 POINT

32 A 64 a \$2 85

UNRIVALED BICYCLE MANUFACTURE
Eighty-Seven Thousand Dollars Required
1234567890

18 POINT

12 A 24 a \$3 05

FASHIONABLE MAID
Modest and Beautiful

10 POINT

24 A 48 a \$2 65

RECEIVING VISITING KNIGHTS
Chicagoan Unprecedented Growth

6 POINT

32 A 64 a \$2 30

CONFESSED MURDERER ADMITTING CRIMES
Very Extensive Southern Australia Diamond Fields
American Type Founders Company
1234567890

GOTHIC EXTRA CONDENSED No 122

72 POINT

4 A 8 a \$10 75

MINERS Grievances

60 POINT

5 A 10 a \$9 65

Undismayed FREEMEN

48 POINT

6 A 12 a \$9 20

SPAIN Cuba

42 POINT

6 A 12 a \$6 90

INDIAN Blanket

36 POINT

6 A 12 a \$4 80

AMERICAN VICTOR
Properly Celebrated

30 POINT

8 A 16 a \$4 80

RENOWNED METEOR
Elaborately Displayed

24 POINT

10 A 20 a \$4 20

INCREASED POPULATION
Black Fighters of the Congo

20 POINT

12 A 24 a \$4 00

CONGRESSIONAL ELECTORATE
Having Four Revolving Wheels

18 POINT

16 A 32 a \$3 80

PROCURING CELEBRATED MEDICINES
Outlaws Chasing the Kings Red Deer

12 POINT

18 A 36 a \$2 35

CHARITABLE LADIES DISTRIBUTING OLD CLOTHING
MICROSCOPIC INDICATIONS

Revised History of Many Celebrated Modern Characters

1234567890

1234567890

GOTHIC No 124

48 POINT

4 A 6 a \$7 65

Evening RIGS

36 POINT

5 A 8 a \$5 75

NORTH OMAHA
Mountain Stream

30 POINT

6 A 10 a \$5 15

FRESH LOBSTERS
Maidens Consumed

24 POINT

8 A 16 a \$4 50

CONVENES
Faith Healer

18 POINT

12 A 24 a \$3 50

MASKED DANCE
Paving of Pathways

12 POINT

18 A 36 a \$2 50

MOONLIGHT MUSICALES
Spanish American Transports

10 POINT

20 A 40 a \$2 10

SEASONS RAPIDLY DEPARTED
Noble Deeds Live and Never Fade

8 POINT

24 A 48 a \$2 05

EXPORTATIONS GREATLY INCREASE
Advance Payments Demanded from All

6 POINT

32 A 64 a \$2 15

EASTERN HAND SPINNING COTTON WHEEL
Modern Machinery Supersedes every Antique Method

GOTHIC WIDE

36 POINT

5 A \$6 30

DIRECTOR

30 POINT

5 A \$4 55

AMERICANS

24 POINT

6 A \$3 85

FALL DESIGNS

20 POINT

10 A \$3 80

BARGAIN SEEKER

16 POINT

8 A \$2 45

BRASS ORNAMENTS

12 POINT

12 A \$2 30

WELCOME

10 POINT

14 A \$1 80

SCANDALOUS

8 POINT

16 A \$1 70

ELECTRIC CARS

6 POINT

22 A \$2 55

MITERING MACHINES

5½ POINT ON 6 POINT

35 A \$2 35

USEFUL ADVERTISING

5 POINT ON 6 POINT

35 A \$2 05

EXTENSIVE IMPROVEMENTS

4 POINT ON 6 POINT

35 A \$2 00

STOCKHOLDERS OF COMPANY
1234567890

3½ POINT ON 6 POINT

35 A \$2 00

SELECT DESIGNS FOR COMPOSITORS
1234567890

GOTHIC WIDE No 2

24 POINT

5 A 7 a \$5 60

NATIONAL
Mexican Border
Herders

20 POINT

6 A 10 a \$4 95

REBUILDING
Suburban Pastime
Domiciled

16 POINT

8 A 12 a \$4 20

OUR MEETING
Nominates European
Candidates

12 POINT

12 A 18 a \$4 15

FRENCH
Entertainer
Bonds

10 POINT

14 A 20 a \$3 15

BANQUET
Choice Dinner
Lunch

8 POINT

16 A 28 a \$3 20

DECORATE
American Boasts
1234567

6 POINT

22 A 32 a \$3 05

PEDESTRIANS
Outdoor Amusements
123456789

GOTHIC No 127

42 POINT

4 A \$3 40

CANARY BIRD

36 POINT

5 A \$2 70

GREAT STORMS

30 POINT

6 A \$2 40

PLEASANT MAIDEN

24 POINT

8 A \$2 25

GROWING REVENUES

20 POINT

10 A \$2 30

CUSTOMER

18 POINT

12 A \$2 00

OCEAN TRIPS

16 POINT

16 A \$2 05

FRESH LIQUOR

12 POINT

18 A \$1 80

TICKET SCALPER

10 POINT

24 A \$1 80

EVENING GREETING
STATIONERY FIRMS

8 POINT

32 A \$1 90

EVANGELICAL MINISTERS
FRICASSEE OF CHICKEN

6 POINT

36 A \$1 60

CONSTRUCT DESIRED BRIDGES
BY THE SEASHORE COURTING

5 POINT ON 6 POINT

36 A \$1 30

FIRST ILLINOIS REGIMENT RECEPTION
RETURN FROM SANTIAGO BATTLEFIELD

4 1/2 POINT ON 6 POINT

42 A \$1 25

HANDSOME AND SERVICEABLE FARM MACHINERY
MINNESOTA AND WISCONSIN FARMING PRODUCTS

3 POINT ON 6 POINT

48 A \$1 10

MATRIMONIAL VOWS AND ADVENT OF THE FIRST-BORN CHILD
INDUSTRIAL DEPARTMENT EMPLOYING BRAINS AND MUSCLES

Shaded Type

Text Letter

Black Letter



STENCIL SERIES

36 POINT

4 A 6 a \$7 90

BRICK Houses

24 POINT

6 A 8 a \$5 20

Quaint CORNER Store

18 POINT

7 A 10 a \$4 20

**RAISING
Hardy Plants
1 2 3 4 5**

12 POINT

10 A 16 a \$3 30

**MOONLIGHT
Frolicsome Parties
1 2 3 4 5 6 7**

AQUATINT SERIES

36 POINT

5 A 7 a \$7 20

**QUESTIONS
Reasonable Answers**

24 POINT

7 A 10 a \$5 55

**MODEST HOMES
Sedate and Retired Persons**

18 POINT

10 A 14 a \$4 25

**ROMANTIC
Mountain Streams
1 2 3 4 5 6 7**

12 POINT

14 A 20 a \$3 70

**HOODWINKED
Business Considerations
1 2 3 4 5 6 7 8**

LITHOTINT SERIES

36 POINT

4 A 8 a \$6 75

MODEST Charmers

24 POINT

6 A 12 a \$5 50

DEPARTING ARTILLERY
Retire National Contractors

18 POINT

8 A 16 a \$4 75

AUTHENTIC ANCIENT RECORDS
Considered Indispensable Luxury 25

HALFTONE SERIES

36 POINT

4 A 8 a \$6 30

MAIDEN Help Miners

24 POINT

6 A 12 a \$4 50

NERVOUSLY GESTICULATED
Greater Variety of Ornaments

18 POINT

8 A 16 a \$3 95

SEVENTY PLEASANT SPECTATORS
Foreign Commissions of Immigration 38

RAPHAEL SERIES

36 POINT

4 A 6 a \$5 50

DEFENCE OUTLINED
Sound Foreign Policies

24 POINT

6 A 8 a \$4 00

GRAND HISTORICAL EVENTS
National Pride Creates Respect

18 POINT

10 A 15 a \$3 25

PROVING HONEST PRINCIPLES ABROAD
Hu rian Doctrine Reflected Broadcast
1 2 3 4 5 6 7 8 9 0

CRAYON SERIES

36 POINT

3 A 5 a \$6 30

Resolved and Decisive

24 POINT

5 A 10 a \$5 15

Generous Republic Thanked

18 POINT

5 A 12 a \$4 05

Triumphant American Diplomats
Concessions Granted 37

TUDOR BLACK

72 POINT

3 A 5 a \$12 00

Dark Echo

48 POINT

5 A 8 a \$8 50

Umpires
Eight and Ten

42 POINT

4 A 12 a \$6 00

Home Run
Stole the Games

36 POINT

4 A 12 a \$5 50

Divide Among
Grand Stand Money

TUDOR BLACK

24 POINT

5 A 15 a \$4 75

Eminent Censure
Award Genius Sparingly
Nation Proves

20 POINT

5 A 15 a \$3 50

Following Afterwards
Reputation is Like the Shadow
Preceding Before

18 POINT

8 A 25 a \$3 40

Sometimes, but Not Always
Accidents that Pass for Misfortunes
Return to our Welfare

12 POINT

9 A 30 a \$2 75

Quicken Movement
The Depletion of Purse
Dead Sure Thing

10 POINT

12 A 36 a \$2 75

Photographs Hanging
Obscure Way Unfavorable
Electric Lights

8 POINT

15 A 50 a \$2 75

Blockheads are Stubborn
Wise People Change Their Minds
1 2 3 4 5 6 7 8 9 0

6 POINT

15 A 50 a \$2 25

Ambition is Pronounced a Lottery
Censure is the Tax a Man Pays to the Public
for being Eminent. Don't all Speak at Once!
1 2 3 4 5 6 7 8 9 0

BOSTON BLACK SERIES

36 POINT

3 A 4 a \$4 50

Latest Modern Book

30 POINT

4 A 6 a \$4 00

Discounted Bank Checks

24 POINT

4 A 10 a \$3 50

Roast Turkey and Mince Pies

18 POINT

5 A 14 a \$3 00

New Mexico Board of Public Directors

12 POINT

5 A 18 a \$2 75

Discussions on Printed Business Catalogues
1234567890

PARISIAN BLACK No 120

24 POINT

5 A 12 a \$5 30

Chinamen Pursue Mistake

18 POINT

5 A 12 a \$3 85

24 Recruits to Desert Comrades

12 POINT

6 A 16 a \$3 40

Present Million 36

10 POINT

8 A 24 a \$3 25

Elections Bewilder 24

8 POINT

8 A 24 a \$2 75

Rest Beneath Shade Trees

6 POINT

10 A 30 a \$2 75

45 Pleased Husbandmen Return

BLACK No 12

36 POINT

3 A 6 a \$6 34

Boston Herald
South Acton Globe
Daily Times

30 POINT

4 A 6 a \$4 69

London Telegram
Camden Weekly News
Denver Union

24 POINT

4 A 10 a \$4 64

American Stamp Review
Memphis Tri-weekly Advertiser
Engraver and Printer

12 POINT

10 A 28 a \$3 90

Consuming the Output of 257 Paper Mills
Circulation Beyond the Limit of Figurative Expression
Advertising Rates Merely Nominal

CAXTON BLACK

54 POINT

3 A 5a \$7 80

Ancient Scribe Rich and Wise

6 POINT

14 A 45 a \$1 75

The Hero's Death

Life's parting beams were in his eye,
 Life's closing accents on his tongue,
 When round him, peaking to the sky,
 The shout of victory rung!
 Then, ere his gallant spirit fled,
 A smile so bright illumed his face—
 Oh! never, of the light it shed,
 Shall memory lose a trace!

His was a death whose rapture high
 Transcended all that life could yield;
 His warmest prayer was so to die,
 On the red battle-field!
 And they may feel, who loved him most,
 A pride so holy and so pure—
 Safe hath no power o'er those who boast
 A treasure thus secure!

42 POINT

3 A 9a \$5 10

Penthesilean Benefactor Tenders Highest Award

[HISTORICAL NOTE.—*Caxton Black* is a reproduction of the chief type made and used by WILLIAM CAXTON, the first English printer. He finished his first book, "*The Dictes and Sayings of the Philosophers*," A. D. 1477. This paragraph is set in *Caſlon Old Style*, cut by WILLIAM CASLON, A. D. 1722. *Caſlon Old Style*, *Caxton Black* and *Priory Text*, all shown in this book and exclusively made in America by the American Type Founders Company, are the most ancient type faces now in use in English speaking countries.]

8 POINT

12 A 40a \$2 15

Sar O'er the Sea

Where are the vintage songs
 Wandering in glee?
 Where dance the peasant bands
 Joyous and free?
 Under a kind blue sky,
 Where doth my birthplace lie?
 —Sar o'er the sea!

Where floats the myrtle-scent
 O'er vale and lea,
 When evening calls the dove
 Homewards to flee?
 Where doth the orange gleam
 Soft on my native stream?
 —Sar o'er the sea!

CAXTON BLACK

30 POINT

4 A 12 a \$3 80

Children Eagerly Listen to the
Beautiful Strains of the Violin
while its Echoes are Resounding

12 POINT

10 A 30 a \$2 35

The Bird at Sea

Bird of the greenwood,
Oh! why art thou here?
Leaves dance not o'er thee,
Flowers bloom not near.

All the sweet waters
Far hence are at play—
Bird of the greenwood,
Away, away!

Where the mast quivers
Thy peace will not be,
As 'midst the waving
Of wild rose and tree.

9 POINT

10 A 30 a \$2 15

Sairies' Recall

While the blue is richest
In the starry sky,
While the softest shadows
On the greensward lie,
While the moonlight slumbers
In the lily's urn,
Bright elves of the wild wood,
Oh! return, return!

Round the forest fountain,
On the river shore,
Let your silvery laughter
Echo yet once more!
While the joyous bounding
Of your dewy feet
Rings to that old chorus:
"The daisy is so sweet!"

18 POINT

6 A 18 a \$2 75

Music is the living source of all social pleasures; it soothes Violent Impulses of Man, dignifies Religious and Civic Ceremonies, and educates the aesthetic taste of the human family

YONKERS SERIES

48 POINT

3 A 8 a \$6 95

Oriental Stream

36 POINT

4 A 8 a \$4 50

Gallant Tribe Leaders

30 POINT

5 A 10 a \$3 85

Southern Chivalry
Truly Proverbial Beauty

24 POINT

8 A 15 a \$3 45

Local Taxes
Helpless Victim

14 POINT

10 A 20 a \$2 30

Combined Efforts
General Task System

12 POINT

15 A 25 a \$2 30

Reactionary Movement
Partisan Doctrines Exploded

10 POINT

20 A 30 a \$2 25

Prosperous Legislators
Pandemonium Reigns Supreme

8 POINT

25 A 40 a \$2 10

Society for the Suppression of
Independent Thought among Bachelors

6 POINT

30 A 50 a \$2 15

Professional Philanthropic Reformers
Inconsistent Preachers and Impractical Teachers

1234567890

1234567890

TITLE BLACK SERIES

36 POINT

3 A 6 a \$6 10

**Free Lance
Unfettered Press**

24 POINT

4 A 8 a \$4 45

**Public Speakers
Time-Honored Customs**

18 POINT

5 A 10 a \$3 40

**Moonlight Association
Uncertainty of Forked Lightning**

12 POINT

7 A 16 a \$3 00

**Full Game Bags
National Coon Hunt
Great Victory**

8 POINT

8 A 20 a \$2 70

**Hills and Valleys
Mountain Summer Jaunts
Dining in the Woods
1 2 3 4 5 6 7 8 9 0**

10 POINT

8 A 20 a \$2 85

**Temperate Customs
Guarantees of Longevity
Fourscore Years**

6 POINT

10 A 28 a \$2 50

**Microscopic Revelations
Voyages Through a Drop of Water
Customs of the Inhabitants
1 2 3 4 5 6 7 8 9 0**

PRIORY TEXT No 2

36 POINT

5 A 8 a \$6 00

Bankers Daughter
Saved from the Enemy

30 POINT

6 A 10 a \$5 00

William S. Chanfrau
Kit, the Arkansas Travellers

24 POINT

6 A 15 a \$4 25

Gumdrop Poisoned Family
The Revenge of the Candy Woman
Howard Athenaeum

18 POINT

8 A 20 a \$4 00

Three Guardsmen, Two Orphans
The Milkwhite Flag, and Telephone Girls
Conserbatory of Music

12 POINT

8 A 24 a \$3 19

Richard Mansfield Alone in New London
Midsummer Nights Dream on the Streets of New York

1 2 3 4 5 6 7 8 9 0

PRIORY TEXT No 1

14 POINT

8 A 24 a \$3 64

All Photo-Engravings are produced by means of photography. It is a fact worthy of note that experimenting in photographic engraving gave rise to photography itself. The aim of Niepce, when he began his researches, was not only to fix the image he obtained by the camera obscura upon a metal plate,

12 POINT

12 A 32 a \$3 08

But to convert this plate into an engraving which could be used on a printing press; but his early death prevented perfecting the process to which he had devoted much time and study. From that time experimenting has been continued by several others, and the result is the production of a number of different processes. A popular one is the swelled gelatine process, though handling 2468

10 POINT

16 A 40 a \$3 42

This method of engraving has an advantage over wood engraving in the matter of cheapness; but it has counterbalancing disadvantages, and there are many subjects in which wood engraving surpasses all methods of process engraving. To reproduce a drawing for printing purposes, the picture should be formed of clean, sharp, and very black lines or dots on perfectly white paper. Flat tints and washed or blurred shadows will not answer, unless they are first translated into lines or stipple. Where an engraving is to represent machinery, the 13579

8 POINT

16 A 44 a \$3 00

Object is photographed twice the size the plate is to be when finished. The photograph, or silver print, as it is technically called, on which the drawing is to be made, is not toned, but simply fixed in a fresh fixing bath, and then thoroughly washed and dried. It is now ready for the artist, who, with pen and suitable ink, draws directly on the silver print, portraying in delicate lines and dots the lights and shadows of the photograph. After the drawing is complete the photograph is bleached, by pouring upon it an alcoholic solution of bi-chloride of mercury, leaving the ink lines of the artist on clean white paper. The advantage of this method of drawing is at once apparent. The artist has the advantage of working directly on and over

HAMBURG SERIES

30 POINT

5 A 12 a \$4 45

Night Blooming Rosebud

24 POINT

5 A 20 a \$4 35

Achieved Success
Persistent Washingtonians

22 POINT

6 A 20 a \$3 50

Exquisitely Flavored
Fancy Mecklenburg Horseradish

18 POINT

10 A 20 a \$3 70

Eschewed Absurd Notions
Medieval Connoisseurs Excellent Taste

14 POINT

15 A 25 a \$3 30

Often Take Place in Nature
Periodic Transitions from Mountain to Valley

12 POINT

15 A 30 a \$2 85

International Favorites
Become Established Faces

10 POINT

15 A 30 a \$2 50

Developments Outstride
Time in the Art Preservative

8 POINT

20 A 40 a \$2 45

Fashions in Printing Types
Multiply Each Succeeding Season

6 POINT

30 A 50 a \$2 35

American Enterprise Produce Every
Imaginable Device for the Saving of Labor

1234567890

1234567890

CADET SERIES

36 POINT

3 A 6a \$4 50

Eastern Freight House

24 POINT

5 A 9a \$3 75

Rhode Island Musical Society

18 POINT

6 A 10a \$3 25

Washington Veterinary Commissioners

16 POINT

7 A 12a \$3 00

Our George Dewey

14 POINT

8 A 14a \$3 00

Honest Counting Room

10 POINT

16 A 22a \$2 75

Patented in the United States

12 POINT

12 A 18a \$3 00

Ornamental Typography

BLACK SERIES

24 POINT NO 22

6 A 14a \$3 00

Dawson Advance

18 POINT NO 22

6 A 20a \$2 75

Bruckstone Treasurers

10 POINT NO 11

12 A 32a \$3 59

Question the Present Characters

12 POINT NO 22

9 A 30a \$2 50

Children Wandering Homeward

BLACK No 13

12 POINT

10 A 40a \$4 49

Sickness Reconciled Patiently

10 POINT

16 A 40a \$3 74

Greatest American Bicycle Travelers

6 POINT

20 A 62a \$3 63

Grasping Physicians, and some who are not quite so greedy, are Adepts at Making out Bills \$2356

8 POINT

20 A 50a \$3 78

Doctor Soakem's Policy is to prolong your complaint so that he can hang to his job 89

MODERN TEXT No 40

60 POINT

3 A 5 a \$10 35

Graphic Sketch

48 POINT

5 A 10 a \$12 60

New Tin

36 POINT

6 A 14 a \$9 85

Young Boy

30 POINT

6 A 14 a \$6 45

Shining Morn

24 POINT

8 A 20 a \$5 20

Cheering the Winner

18 POINT

10 A 28 a \$4 80

Wonderful Predestinators

12 POINT

12 A 32 a \$4 15

Magnificent Land Enterprise

AUGUSTAN TEXT

24 POINT

6 A 14 a \$5 17

Newspaper Publishing Companies

18 POINT

8 A 16 a \$4 49

Europeans Manufacture Christmas Specialties

12 POINT

8 A 24 a \$3 34

Dramatic Corporation
Grandest Theatrical Product

10 POINT

10 A 40 a \$3 02

Mountain Climber Descending
Experienced Guide Smoking Cigarettes

8 POINT

20 A 40 a \$3 06

Another German Warbling Society
Elegant Concerts and Laughable Masquerades

6 POINT

20 A 70 a \$2 93

Responsible Astronomers Cause Excitement
Telegraph Operators Refusing Corporation Dividends

1 2 3 4 5 6 7 8 9 0

1 2 3 4 5 6 7 8 9 0

CONDENSED BLACK No 42

36 POINT

6 A 14 a \$7 75

The Delaware County Bugle

30 POINT

6 A 14 a \$6 00

Magazine Published Every Week

24 POINT

8 A 20 a \$5 20

Wire Frame Maker

18 POINT

12 A 32 a \$5 50

Contractors for Building

12 POINT

12 A 32 a \$3 95

Lightfoot Dancing Masters

10 POINT

20 A 52 a \$4 55

Annual International Boat Race

CONDENSED BLACK SHADED No 40

36 POINT

6 A 14 a \$7 90

The Southern Trade Journal

30 POINT

6 A 14 a \$6 00

New England Monthly Reporter

24 POINT

8 A 20 a \$5 10

Delectable Apricots

18 POINT

12 A 32 a \$5 75

Passing Spurious Coin

12 POINT

12 A 32 a \$4 00

Fashionable Physiognomist

10 POINT

20 A 52 a \$4 55

Panorama of Yellowstone Valley

MEDIÆVAL No 10

42 POINT

4 A 6 a \$5 90

Union Cabernacle Choirs

30 POINT

4 A 8 a \$3 70

Manuscript Ecclesiastical Allegorical

24 POINT

5 A 10 a \$3 50

Regular Company 1902 Birglist Veterans
Triennial Autumn Handicaps

CHAPEL TEXT No 30

42 POINT

4 A 10 a \$7 00

Five Instrumental Concert

30 POINT

5 A 12 a \$5 05

Acrobatic and Pugilistic Barbarians

24 POINT

6 A 15 a \$3 85

Southern Amusement

18 POINT

10 A 25 a \$4 90

Daily Riotous Carousals

12 POINT

12 A 30 a \$3 80

Self-Made Statesmen
Convention of Representatives

1234567890

10 POINT

15 A 40 a \$3 95

Disappointing Contemplation
American Charitable Association

1234567890

Specimens of...



German
Hebrew
Greek
Rabbinic
Armenian
Russian

*Die Folgenden sind nur einige unserer deutschen
Schriften. Wir haben eine sehr reiche Auswahl und
sind bereit, auf Wunsch Schriftproben vorzulegen.*



American Type Founders Co.

Covering the Continent

SELF SPACING GERMAN *For description of Self Spacing Type, see pages 128 and 129*

6 POINT NO 42

Unit of measure, 12 to Pica

Auf keinem Gebiete waren die Fortschritte seit vier Jahrhunderten so gering wie in der Kunst des Schriftsetzens. Die hier und da in Gebrauch befindlichen Maschinen sind durchaus unvollkommen; die bei weitem größte Masse der üblichen Schrift ist noch genau der Art wie vor vierhundert Jahren. Wenn Franklin heute wieder vor dem Kasten stände, würde er nichts Neues zu lernen haben. Die Schriftgießerei ist hinter der wunderbaren Vervollkommnung der Pressen vollständig zurückgeblieben; die vergrößerte Geschwindigkeit im Schriftsetzen beruht ausschließlich in der Vermehrung der Kästen. Alle Bemühungen, diesem Uebelstande abzuhelfen, gingen darauf hinaus, Setzmaschinen zu erfinden, statt die Art und Weise des Handsetzens zu verbessern. Eins der Haupthindernisse, welches den Setzmaschinen im Wege stand, ist die Nothwendigkeit, mit der Hand zu „justiren“. Daran scheiterte hauptsächlich die Einführung dieser Maschinen. Es liegt daher auf der Hand, daß jeder

A B C D E F G H I J K L M N O P Q R S T U V W X Y Z
1234567890

8 POINT NO 43

Unit of measure, 11 to Pica

Auf keinem Gebiete waren die Fortschritte seit vier Jahrhunderten so gering wie in der Kunst des Schriftsetzens. Die hier und da in Gebrauch befindlichen Maschinen sind durchaus unvollkommen; die bei weitem größte Masse der üblichen Schrift ist noch genau der Art wie vor vierhundert Jahren. Wenn Franklin heute wieder vor dem Kasten stände, würde er nichts Neues zu lernen haben. Die Schriftgießerei ist hinter der wunderbaren Vervollkommnung der Pressen vollständig zurückgeblieben; die vergrößerte Geschwindigkeit im Schriftsetzen beruht ausschließlich in der Vermehrung der

A B C D E F G H I J K L M N O P Q R S T U V W X Y Z
1234567890

9 POINT NO 41

Unit of measure, 10 to Pica

Auf keinem Gebiete waren die Fortschritte seit vier Jahrhunderten so gering wie in der Kunst des Schriftsetzens. Die hier und da in Gebrauch befindlichen Maschinen sind durchaus unvollkommen; die bei weitem größte Masse der üblichen Schrift ist noch genau der Art wie vor vierhundert Jahren. Wenn Franklin heute wieder vor dem Kasten stände, würde er nichts Neues zu lernen haben. Die Schriftgießerei ist hinter der wunderbaren Vervollkommnung der Pressen vollständig zurückgeblieben; die vergrößerte Geschwindigkeit im

A B C D E F G H I J K L M N O P Q R S T U V W X Y Z
1234567890

10 POINT NO 40

Unit of measure, 9 to Pica

Auf keinem Gebiete waren die Fortschritte seit vier Jahrhunderten so gering wie in der Kunst des Schriftsetzens. Die hier und da in Gebrauch befindlichen Maschinen sind durchaus unvollkommen; die bei weitem größte Masse der üblichen Schrift ist noch genau der Art wie vor vierhundert Jahren. Wenn Franklin heute wieder vor dem Kasten stände, würde er nichts Neues zu lernen haben. Die Schriftgießerei ist hinter der wun-

A B C D E F G H I J K L M N O P Q R S T U V W X Y Z
1234567890

GERMAN No 153

6 POINT GERMAN NO 153

Auf keinem Gebiete waren die Fortschritte seit vier Jahrhunderten so gering wie in der Kunst des Schriftsetzens. Die hier und da in Gebrauch befindlichen Maschinen sind durchaus unvollkommen; die bei weitem größte Masse der üblichen Schrift ist noch genau der Art wie vor vierhundert Jahren. Wenn Franklin heute wieder vor dem Kasten stände, würde er nichts Neues zu lernen haben. Die Schriftsetzerei ist hinter der wunderbaren Vervollkommnung der Pressen vollständig zurückgeblieben; die vergrößerte Geschwindigkeit im Schriftsetzen beruht ausschließlich in der Vermehrung der Kästen. Alle Bemühungen, diesem Uebelstande abzuhelpfen, gingen darauf hinaus, Setzmaschinen zu erfinden, statt die Art und Weise des Handsetzens zu verbessern. Eins der Haupthindernisse, welches den Setzmaschinen im Wege stand, ist die Nothwendigkeit, mit der Hand zu „justiren“. Daran scheiterte hauptsächlich die Einführung dieser Maschinen. Es liegt daher auf der Hand, daß jeder Plan zur Verbesserung unserer Setzmethoden in erster Linie die Justirung zu vereinfachen hat, denn da dies der Punkt ist, um den sich die Sache

abcdefghijklmnopqrstuvwxyz

\$1234 ABCDEFGHJKL MNOPQRSTUVWXYZ 567890

8 POINT GERMAN NO 153

Auf keinem Gebiete waren die Fortschritte seit vier Jahrhunderten so gering wie in der Kunst des Schriftsetzens. Die hier und da in Gebrauch befindlichen Maschinen sind durchaus unvollkommen; die bei weitem größte Masse der üblichen Schrift ist noch genau der Art wie vor vierhundert Jahren. Wenn Franklin heute wieder vor dem Kasten stände, würde er nichts Neues zu lernen haben. Die Schriftsetzerei ist hinter der wunderbaren Vervollkommnung der Pressen vollständig zurückgeblieben; die vergrößerte Geschwindigkeit im Schriftsetzen beruht ausschließlich in der Vermehrung der Kästen. Alle Bemühungen, diesem Uebelstande abzuhelpfen, gingen darauf hinaus,

abcdefghijklmnopqrstuvwxyz

\$1234 ABCDEFGHJKL MNOPQRSTUVWXYZ 567890

10 POINT GERMAN NO 153

Auf keinem Gebiete waren die Fortschritte seit vier Jahrhunderten so gering wie in der Kunst des Schriftsetzens. Die hier und da in Gebrauch befindlichen Maschinen sind durchaus unvollkommen; die bei weitem größte Masse der üblichen Schrift ist noch genau der Art wie vor vierhundert Jahren. Wenn Franklin heute wieder vor dem Kasten stände, würde er nichts Neues zu lernen haben. Die Schriftsetzerei ist hinter der wunderbaren Vervollkommnung der Pressen vollständig zu-

abcdefghijklmnopqrstuvwxyz

\$1234 ABCDEFGHJKL MNOPQRSTUVWXYZ 567890

11 POINT GERMAN NO 153

Auf keinem Gebiete waren die Fortschritte seit vier Jahrhunderten so gering wie in der Kunst des Schriftsetzens. Die hier und da in Gebrauch befindlichen Maschinen sind durchaus unvollkommen; die bei weitem größte Masse der üblichen Schrift ist noch genau der Art wie vor vierhundert Jahren. Wenn Franklin heute wieder vor dem Kasten stände, würde er nichts Neues zu lernen

abcdefghijklmnopqrstuvwxyz

\$1234 ABCDEFGHJKL MNOPQRSTUVWXYZ 567890

GERMAN No 121

6 POINT GERMAN NO 121

Natur! Wir sind von ihr umgeben und umschlungen—unvermögend, aus ihr herauszutreten, und unvermögend, tiefer in sie hineinzukommen. Ungebeten und ungewarnt nimmt sie uns in den Umlauf ihres Tages auf und treibt sich mit uns fort, bis wir ermüdet sind und ihrem Arme entfallen. Sie schafft ewig neue Gestalten; was da ist, war noch nie; was war, kommt nicht wieder—Jedes ist neu und doch immer das Alte. Wir leben mitten in ihr und sind ihre Freunde. Sie spricht unaufhörlich mit uns und verrät uns ihr Geheimnis nicht. Wir wirken beständig auf sie ein und haben doch keine Gewalt über sie. Große und heilige Natur! in deinen Hallen wandelt der Mensch und lernt von Stauden und Bäumen; sein Auge ruht wie ein Fühlhorn am blauen Himmel, und sucht nach dem, nach welchem sich sein Herz in der Brust ausstreckt. Dann wird er selbst zum Priester dieses Tempels eingeweicht; mit Thränen endet er die Feierlichkeit. Durch Menschenliebe predigt er andern Menschen, durch Trost, durch Mitleid und Hilfe.—Wer kann die unendliche Liebe nicht fühlen, die über uns ausgespannt ist, und uns auf dieser Welt mit Zärtlichkeit gefangen

abcdefghijklmnopqrstuvwxyz

\$1234

ABCDEFGHIJKLMN OPQRSTUVWXYZ

567890

7 POINT GERMAN NO 121

Natur! Wir sind von ihr umgeben und umschlungen—unvermögend, aus ihr herauszutreten, und unvermögend, tiefer in sie hineinzukommen. Ungebeten und ungewarnt nimmt sie uns in den Umlauf ihres Tages auf und treibt sich mit uns fort, bis wir ermüdet sind und ihrem Arme entfallen. Sie schafft ewig neue Gestalten; was da ist, war noch nie; was war, kommt nicht wieder—Jedes ist neu und doch immer das Alte. Wir leben mitten in ihr und sind ihre Freunde. Sie spricht unaufhörlich mit uns und verrät uns ihr Geheimnis nicht. Wir wirken beständig auf sie ein und haben doch keine Gewalt über sie. Große und heilige Natur! in deinen Hallen wandelt der Mensch und lernt von Stauden und Bäumen; sein Auge ruht wie ein Fühlhorn am blauen Himmel, und sucht nach dem,

abcdefghijklmnopqrstuvwxyz

\$1234

ABCDEFGHIJKLMN OPQRSTUVWXYZ

567890

8 POINT GERMAN NO 121

Natur! Wir sind von ihr umgeben und umschlungen—unvermögend, aus ihr herauszutreten, und unvermögend, tiefer in sie hineinzukommen. Ungebeten und ungewarnt nimmt sie uns in den Umlauf ihres Tages auf und treibt sich mit uns fort, bis wir ermüdet sind und ihrem Arme entfallen. Sie schafft ewig neue Gestalten; was da ist, war noch nie; was war, kommt nicht wieder—Jedes ist neu und doch immer das Alte. Wir leben mitten in ihr und sind ihre Freunde. Sie spricht unaufhörlich mit uns und verrät uns ihr Geheimnis nicht. Wir wirken beständig auf sie ein und haben doch keine Gewalt über sie. Große und heilige Natur! in deinen

abcdefghijklmnopqrstuvwxyz

\$1234

ABCDEFGHIJKLMN OPQRSTUVWXYZ

567890

9 POINT GERMAN NO 121

Natur! Wir sind von ihr umgeben und umschlungen—unvermögend, aus ihr herauszutreten, und unvermögend, tiefer in sie hineinzukommen. Ungebeten und ungewarnt nimmt sie uns in den Umlauf ihres Tages auf und treibt sich mit uns fort, bis wir ermüdet sind und ihrem Arme entfallen. Sie schafft ewig neue Gestalten; was da ist, war noch nie; was war, kommt nicht wieder—Jedes ist neu und doch immer das Alte. Wir leben mitten in ihr und sind ihre Freunde. Sie spricht unaufhörlich mit uns und verrät uns ihr Geheimnis nicht. Wir wirken beständig

abcdefghijklmnopqrstuvwxyz

\$1234

ABCDEFGHIJKLMN OPQRSTUVWXYZ

567890

10 POINT GERMAN NO 121

Natur! Wir sind von ihr umgeben und umschlungen—unvermögend, aus ihr herauszutreten, und unvermögend, tiefer in sie hineinzukommen. Ungebeten und ungewarnt nimmt sie uns in den Umlauf ihres Tages auf und treibt sich mit uns fort, bis wir ermüdet sind und ihrem Arme entfallen. Sie schafft ewig neue Gestalten; was da ist, war noch nie; was war, kommt nicht wieder—Jedes ist neu und doch immer das Alte. Wir leben mitten in ihr und sind ihre Freunde. Sie spricht unaufhörlich mit uns und verrät uns ihr Geheimnis nicht. Wir wirken beständig auf sie ein und haben doch keine Gewalt über sie. Große und heilige Natur! in deinen Hallen wandelt der Mensch und lernt von Stauden und

abcdefghijklmnopqrstuwxyz

\$1234 ABCDEFGHIJKLMNOPQRSTUVWXYZ 567890

11 POINT GERMAN NO 121

Natur! Wir sind von ihr umgeben und umschlungen—unvermögend, aus ihr herauszutreten, und unvermögend, tiefer in sie hineinzukommen. Ungebeten und ungewarnt nimmt sie uns in den Umlauf ihres Tages auf und treibt sich mit uns fort, bis wir ermüdet sind und ihrem Arme entfallen. Sie schafft ewig neue Gestalten; was da ist, war noch nie; was war, kommt nicht wieder—Jedes ist neu und doch immer das Alte. Wir leben mitten in ihr und sind ihre Freunde. Sie spricht unaufhörlich mit uns und verrät uns ihr Geheimnis nicht. Wir wirken beständig auf sie ein und haben doch keine Gewalt über

abcdefghijklmnopqrstuwxyz

\$1234 ABCDEFGHIJKLMNOPQRSTUVWXYZ 567890

12 POINT GERMAN NO 121

Natur! Wir sind von ihr umgeben und umschlungen—unvermögend, aus ihr herauszutreten, und unvermögend, tiefer in sie hineinzukommen. Ungebeten und ungewarnt nimmt sie uns in den Umlauf ihres Tages auf und treibt sich mit uns fort, bis wir ermüdet sind und ihrem Arme entfallen. Sie schafft ewig neue Gestalten; was da ist, war noch nie; was war, kommt nicht wieder—Jedes ist neu und doch immer das Alte. Wir leben mitten in ihr und sind ihre Freunde. Sie spricht

abcdefghijklmnopqrstuwxyz

\$1234 ABCDEFGHIJKLMNOPQRSTU 567890

14 POINT GERMAN NO 121

Natur! Wir sind von ihr umgeben und umschlungen—unvermögend, aus ihr herauszutreten, und unvermögend, tiefer in sie hineinzukommen. Ungebeten und ungewarnt nimmt sie uns in den Umlauf ihres Tages auf und treibt sich mit uns fort, bis wir ermüdet sind und ihrem Arme entfallen. Sie schafft ewig neue

18 POINT GERMAN NO 121

20 A 100 a \$12 48

Natur! Von der Natur umgeben und umschlungen, sind wir unvermögend aus ihr herauszutreten, und unvermögend tiefer in sie hineinzukommen. Ungebeten und ungewarnt nimmt sie uns in

24 POINT GERMAN NO 121

14 A 40 a \$12 00

Natur! Wir sind stets von ihr umgeben und umschlungen, sind unvermögend aus ihr herauszutreten, und unvermögend tiefer

30 POINT GERMAN NO 121

8 A 60 a \$12 00

Von der Natur umgeben und umschlungen, sind wir unvermögend aus ihr

GERMAN No 155

6 POINT GERMAN NO 155

14 A 42 a \$2 25

8 POINT GERMAN NO 155

12 A 36 a \$2 50

Natur! Wir sind von ihr umgeben und umschlungen—unvermögend, aus ihr herauszutreten, und unvermögend, tiefer in sie hineinzudringen. Angebeten und ungewarnt nimmt sie uns in den Umlauf ihres Tages auf und treibt sich mit uns fort, bis wir ermüdet sind und ihrem Arme entfallen. Sie schafft ewig neue Gestalten; was da ist, war noch nie; was war, kommt nicht wieder—Jedes ist neu und doch immer wieder das Alte. Wir leben mitten in ihr und sind ihre

abcdefghijklmnopqrstuvwxyz

\$1234 ABCDEFGHJKL MNOPQR 567890

Natur! Wir sind von ihr umgeben und umschlungen—unvermögend, aus ihr herauszutreten, sowie unvermögend, tiefer in sie hineinzukommen. Angebeten und ungewarnt nimmt sie uns in den Umlauf ihres Tages auf und treibt sich mit uns fort, bis wir ermüdet werden und ihrem Arme entfallen

abcdefghijklmnopqrstuvwxyz

\$1234 ABCDEFGHJKL 567890

9 POINT GERMAN NO 155

12 A 36 a \$2 75

Natur! Wir sind von ihr umgeben und umschlungen—unvermögend, aus ihr herauszutreten, und unvermögend, tiefer in sie hineinzudringen. Angebeten und ungewarnt nimmt sie uns in den Umlauf ihres Tages auf und treibt sich mit uns fort, bis wir ermüdet sind und ihrem Arme entfallen. Sie schafft ewig neue Gestalten; was da ist, war noch nie; was war, kommt nie wieder—Jedes ist neu und doch immer das Alte. Wir leben mitten in ihr und sind ihre Freunde. Sie spricht unaufhörlich mit uns und ver-

abcdefghijklmnopqrstuvwxyz

\$1234 ABCDEFGHJKL MNOPQR STUVWXYZ 567890

10 POINT GERMAN NO 155

10 A 30 a \$2 75

Natur! Wir sind von ihr umgeben und umschlungen—unvermögend, aus ihr herauszutreten, und unvermögend, tiefer in sie hineinzukommen. Angebeten und ungewarnt nimmt sie uns in den Umlauf ihres Tages auf und treibt sich mit uns fort, bis wir ermüdet sind und ihren Armen entfallen. Sie schafft ewig neue Gestalten; was da ist, war noch nie; was war, kommt nicht wieder—Jedes ist neu, jedoch stets das Alte

abcdefghijklmnopqrstuvwxyz

\$1234 ABCDEFGHJKL MNOPQR STUVW 567890

12 POINT GERMAN NO 155

8 A 24 a \$3 00

Natur! Wir sind von ihr umgeben und umschlungen—unvermögend, aus ihr herauszutreten oder tiefer in sie einzudringen. Angebeten und ungewarnt nimmt sie uns in den Umlauf ihres Tages auf und treibt sich mit uns fort, bis wir ermüdet sind und ihrem Arme

abcdefghijklmnopqrstuvwxyz

\$1234 ABCDEFGHJKL MNOPQR ST 567890

GERMAN SERIES

60 POINT GERMAN NO 30

4 A 8 a \$10 50

Schöne Bilder
Neues Kleinod

42 POINT GERMAN NO 32

4 A 10 a \$8 00

Werke für Musiker
Deutsche Melodien

48 POINT GERMAN NO 31

5 A 10 a \$9 50

Wirf nicht Steine
Heiliges Denkmal

42 POINT GERMAN NO 31

4 A 10 a \$7 50

Schätze deine Eltern
Glückliche Menschen

GERMAN TITLE CONDENSED

— F B —

72 POINT NO 150

3 A 8 a \$12 00

Deutsche Treue

60 POINT NO 150

4 A 10 a \$13 00

Gute Rheinweine

42 POINT NO 150

4 A 10 a \$10 00

Naturfind

30 POINT NO 150

8 A 20 a \$6 60

Hochzeitglocken

18 POINT NO 150

9 A 30 a \$4 50

Delikates Gabelfrühstück

12 POINT NO 150

16 A 50 a \$4 50

Das Buch der Natur liegt für die
Blicke der Menschen aufgeschlagen

10 POINT NO 150

16 A 50 a \$3 50

Das Buch der Natur liegt seit Jahr-
tausenden geöffnet vor dem Blicke der

8 POINT NO 150

16 A 50 a \$3 00

Das Buch der Natur liegt seit Jahrtausen-
den weit aufgeschlagen vor dem Blicke des
1 2 3 4 5 6 7 8 9 0

36 POINT NO 150

5 A 15 a \$7 75

Waldfräuter

20 POINT NO 150

8 A 24 a \$5 75

Columbia Brauerei

14 POINT NO 150

12 A 40 a \$4 00

Glückliche Jugendherrlichkeit

11 POINT NO 150

16 A 50 a \$3 75

Das Buch der Natur lag aufgeschla-
gen vor dem Blicke des Menschen seit

9 POINT NO 150

16 A 50 a \$3 15

Das Buch der Natur liegt seit Jahrtausen-
den weit aufgeschlagen vor dem Blicke des

6 POINT NO 30

15 A 50 a \$2 00

Das Buch der Natur liegt seit Jahrtausenden aufge-
schlagen vor dem Blicke des Menschen. Es ist in großen
1 2 3 4 5 6 7 8 9 0

MODERN FRAKTUR

42 POINT

4 A 10 a \$6 55

Schakfammer-Gericht

30 POINT

5 A 15 a \$4 90

Unruhige Gesellschaft
Praktische starke Germanen

24 POINT

6 A 20 a \$4 05

Fürchterlicher Donner Schlag
Umsturz der Monarchie in Frankreich

18 POINT

6 A 20 a \$2 70

Sanfte Schritte
Tragischer Aufenthalt

12 POINT

12 A 40 a \$3 00

Sämmtliche Schriften
Messinglinien und Ornamente

10 POINT

12 A 40 a \$2 25

Humoristische Erzählungen
Unterhaltende Lektüre und Aufsätze

8 POINT

15 A 50 a \$2 30

Geschlechts- und Nervenleiden
Aussicht medizinischer Sachverständiger
1234567890

14 POINT

9 A 30 a \$2 80

Frische reine Luft
Windmühlen für Fabriken

11 POINT

12 A 40 a \$2 40

Berzauberte Trinkthalen
Ehrenmoment der Freiheitskämpfer

9 POINT

15 A 50 a \$2 60

Ein herrlicher Sonnenaufgang
Fruchtbare Resultate einer Untersuchung

6 POINT

15 A 50 a \$2 00

Originelle Karikaturen und Witze
Besprechung über Tagesereignisse unserer Politik
1234567890

HEINTZEMANN SERIES

30 POINT

6 A 20a \$7 10

Erwiger Kampf um Freiheit

24 POINT

8 A 25 a \$5 80

Vorsicht ist die Mutter der Weisheit

18 POINT

10 A 30 a \$4 95

Ein ehrenvoller Name und guter Charakter

14 POINT

12 A 40 a \$4 80

**Muntere Geister
Biel Humor und Wize**

12 POINT

12 A 40 a \$3 35

**Ohne Mühe kein Preis
Große Meister schöner Künste**

10 POINT

12 A 40 a \$2 85

**Reiche Auswahl guter
Materialien und neuester Schriften**

9 POINT

12 A 50 a \$2 60

**Mit Ehrlichkeit und Fleiß
Kommt man am besten durch die Welt**

8 POINT

15 A 50 a \$2 60

**Das menschliche Leben bietet dem
Scharfen Beobachter ein gutes Lehrbild**
1234567890

6 POINT

15 A 50 a \$2 15

**Morgenstunde hat Gold im Munde
Man soll niemals den Tag vor dem Abend loben**
1234567890

CONDENSED GERMAN BLACK No 150

30 POINT

4 A 10 a \$3 50

Römisches Soldatenlager im Winter

24 POINT

4 A 10 a \$2 50

Nubische Elephantenjäger und Sklaventreiber

18 POINT

8 A 20 a \$3 50

Modernes Sittenbild 56

12 POINT

16 A 50 a \$4 50

Neue Hamburger Dampferlinien 78

GERMAN TITLE No 2

30 POINT

4 A 10 a \$3 80

Glückliche junge Arbeiter

24 POINT

7 A 20 a \$4 75

Thue Recht und scheue Niemand

18 POINT

7 A 20 a \$3 15

**Großes Konzert im Walde
Das Abschiedslied der fröhlichen Sänger**

14 POINT

8 A 25 a \$2 70

**Praktische Theorie
Sehr einfach und deutlich**

12 POINT

9 A 30 a \$2 65

**Der König der Wüste
Ermahnung an seine Rekruten**

10 POINT

12 A 40 a \$2 45

**Wenn Weiber schweigen
Arrangirt Mephisto seinen Reigen
1234567890**

8 POINT

15 A 50 a \$2 50

**Traumbuch für verliebte Backfische
Seifenblasen und prächtige Luftschlöffer
1234567890**

BOLDFACE GERMAN

12 POINT

9 A 30 a \$3 00

**Schwabenstreiche der deutschen Studenten
Das Heidelberger Faß hat so manchen Durst gestillt**

10 POINT

12 A 40 a \$3 00

**Speziell für Patrioten
Abfahrt deutscher Soldaten**

9 POINT

15 A 50 a \$3 35

**Eine Rose ohne Dornen
Ist wie ein Baum ohne Blätter**

8 POINT

15 A 50 a \$2 95

**Wunderbare Erfindungen
Photographien der Sternentwelt
1234567890**

6 POINT

15 A 50 a \$2 60

**Unterirdische Tiefen der Wälder
Die Lebensadern der Felder und Quellen
1234567890**

GERMAN FULL FACE

30 POINT

6 A 15 a \$8 00

Neueste Wiener Moden

24 POINT

6 A 15 a \$6 00

Kurverwaltung in Marienbad

18 POINT

7 A 20 a \$4 50

Alter Turnverein

12 POINT

7 A 20 a \$3 00

Lawinen im Hochgebirge

11 POINT

9 A 30 a \$3 00

Das Buch der Natur ist den
Blicken des Menschen offen

10 POINT

12 A 40 a \$3 50

Das Buch der Natur liegt geöff-
net seit Jahrtausenden vor dem

9 POINT

16 A 50 a \$3 85

Das Buch der Natur liegt geöffnet
seit Jahrtausenden vor dem Blicke

8 POINT

16 A 50 a \$3 50

Das Buch der Natur liegt geöffnet
seit Jahrtausenden vor den Blicken

7 POINT

16 A 50 a \$3 25

Das Buch der Natur liegt seit Jahrtau-
senden aufgeschlagen vor der Menschheit.
1 2 3 4 5 6 7 8 9 0

6 POINT

16 A 50 a \$3 00

Das Buch der Natur liegt seit Jahrtausen-
den aufgeschlagen vor der Menschheit. G S
1 2 3 4 5 6 7 8 9 0

TEUTON BLACK

30 POINT

6 A 15 a \$6 30

Ohne Angst

24 POINT

8 A 20 a \$5 25

Sommer-Nächte

18 POINT

10 A 25 a \$4 40

Eile nur mit Weile

14 POINT

12 A 30 a \$3 65

Historische Erzählungen

12 POINT

12 A 30 a \$3 05

Deutsche Lieder und Musik

10 POINT

15 A 40 a \$3 35

Zauber holder Weiblichkeit

8 POINT

20 A 50 a \$3 15

Der letzte Bericht der Kommissäre
1 2 3 4 5 6 7 8 9 0

6 POINT

20 A 50 a \$2 90

Ansicht eines Naturforschers aus Mexiko
1 2 3 4 5 6 7 8 9 0

GERMAN TITLE No 122

42 POINT

3 A 6 a \$5 35

Dummer Bagabund

36 POINT

3 A 6 a \$3 95

Zugend und Freiheit

30 POINT

4 A 10 a \$4 80

Verschiedene Bemerkung

24 POINT

7 A 20 a \$4 75

Die Weinstube

18 POINT

7 A 20 a \$3 50

Nachtschwärmerei

14 POINT

8 A 25 a \$3 25

Kühnste Versäumnis der Wissenschaft und

12 POINT

9 A 30 a \$3 10

Kühne Versäumnis der Wissenschaft und Kunst

11 POINT

9 A 30 a \$2 60

Das Buch der Natur liegt seit Jahrtausenden vor den Blicken des Menschen. Es

10 POINT

12 A 40 a \$3 00

Das Buch der Natur liegt seit Jahrtausenden aufge- schlagen vor dem Blicke des

9 POINT

15 A 50 a \$3 95

Das Buch der Natur liegt seit Jahrtausenden vor dem Blick des Menschen. Es ist in gro-

8 POINT

15 A 50 a \$3 15

Das Buch der Natur liegt seit Jahrtausenden vor dem Blicke des Menschen. Es ist in großen

7 POINT

15 A 50 a \$3 10

Das Buch der Natur liegt seit Jahr- tausenden aufgeschlagen vor dem Blicke des Menschen. Es ist in gro-

6 POINT

15 A 50 a \$2 85

Das Buch der Natur ist seit Jahrtausenz- den aufgeschlagen vor dem Blicke des Men- schen. Es ist in großen, herrlichen Zügen

1 2 3 4 5 6 7 8 9 0

1 2 3 4 5 6 7 8 9 0

GERMAN TITLE

60 POINT

3 A 6 a \$10 35

Blaue Augen

48 POINT

4 A 10 a \$10 15

Eine gute Salbe

36 POINT

4 A 10 a \$6 70

Das Lied

30 POINT

4 A 10 a \$4 10

Böse Laute

24 POINT

7 A 20 a \$5 20

Weißer Naben

18 POINT

7 A 20 a \$3 70

Schwere Wolken

14 POINT

8 A 25 a \$3 00

**Goldene Berge
Böhmische Dorfsitten**

12 POINT

9 A 30 a \$3 00

**Schutz und Müller
Köstliche Berliner Witze**

11 POINT

9 A 30 a \$2 35

**Kleine Ursachen haben
Sehr oft große Wirkungen**

10 POINT

12 A 40 a \$3 00

**Einen Kuß in Ehren
Sollten Mädchen gewähren**

9 POINT

15 A 50 a \$3 05

**Der Faule klagt vergebens
Arbeit ist die Würze des Lebens**

8 POINT

15 A 50 a \$3 35

**Ein Zeichen der Zeit
Vereine enttäuschter Liebhaber**

7 POINT

15 A 50 a \$2 25

**Den goldenen Füchsen sind
Keine Trauben weder zu hoch noch zu sauer**

6 POINT

15 A 50 a \$2 25

**Hoch klingt das Lied vom braven Mann
Der auch Pantomime-Tyrannen Trotz bieten kann**

1 2 3 4 5 6 7 8 9 0

1 2 3 4 5 6 7 8 9 0

IHLENBURG EXTENDED

60 POINT

3 A 4a \$11 20

Schriftsetzer

48 POINT

3 A 6a \$9 15

Buchliebhaber

36 POINT

4 A 10a \$7 00

Neue Fachzeitschrift

30 POINT

5 A 12a \$6 45

Deutsches Kunstinstitut

24 POINT

6 A 16a \$5 85

Stylvolle Accidenzarbeiten

18 POINT

10 A 28a \$5 35

**Christoph Sauer
druckte die erste**

15 POINT

12 A 36a \$4 85

**Presse und Schriften
wurden von einigen**

12 POINT

14 A 42a \$4 30

**Bibel in diesem Lande
und zwar in deutscher**

10 POINT

16 A 48a \$3 75

**Freunden in Marburg, wo
er studirt hatte, zugeschickt**

8 POINT

16 A 50a \$3 50

**Sprache, an welcher Arbeit er
vier Jahre thätig war und die
er in 1743 glücklich beendigte**

6 POINT

20 A 60a \$3 20

**Gegen Ende des Werkes jedoch war
Sauer genöthigt seine Schrift selbst zu
gießen. Er starb im September 1758**

IHLENBURG SERIES

60 POINT

3 A 5 a \$9 65

Der alte Meister

48 POINT

3 A 8 a \$7 35

Erfinder Gutenberg

36 POINT

4 A 10 a \$5 40

Stammt aus dem sehr alten

24 POINT

5 A 16 a \$3 80

Ritterlichen Geschlecht der Gensfleisch

18 POINT

8 A 25 a \$3 55

Im Jahre 1332 stand sein Urgroßvater, Rathsherr Frielo Gensfleisch, bei dem Aufstande der Zünfte

12 POINT

15 A 45 a \$3 25

Gegen den Adel von Mainz an der Spitze der Patrizier. Seine zwei Söhne, Peter und Claus, von welchen jener Bürgermeister

8 POINT

18 A 52 a \$2 70

Wurde und die Hauptlinie des Geschlechts fortsetzte, während dieser eine Seitenlinie stiftete, deren Abkommen in dem Jahre 1432 den Beinamen Sorgenloch oder Selgenloch annahm. Der Sohn Peters, Frielo, gründete in der Hauptlinie ebenfalls eine

10 POINT

16 A 50 a \$3 00

Seitenlinie welche nach einem von Peters Gattin G. Gelthus zur Laden zugebrachten Stammhause den Beinamen zur Laden annahm. Der Enkel Peters, welcher ebenfalls den

6 POINT

20 A 60 a \$2 40

Namen Frielo führte, nahm die Else zum Gutenberg, die Erbtöchter des mit ihr erlöschenden Geschlechts der Cämmerer zum Gutenberg, zur Gemahlin und zeugte mit ihr zwei Söhne, Frielo und Johann, von welchen der letztere sich Johann Gensfleisch zum Gutenberg nannte, und die vereinigten Namen der beiden alten Geschlechter durch die Erfindung der Buchdruckerkunst den spätesten Nachkommen überliefert hat.

SCHWABACHER No 2

48 POINT

3 A 8 a \$11 40

Reiche Fürsten

36 POINT

3 A 8 a \$7 00

Alterthümlichkeit!

30 POINT

4 A 10 a \$6 00

Herenmeister Zeitung

20 POINT

5 A 15 a \$5 00

Sieben Herren Kamen Gestern
Deutsche Männer

16 POINT

6 A 18 a \$4 00

Es macht der Saft der Purpurtraube
des Menschen Herz gesund

14 POINT

7 A 20 a \$3 75

Befrängt mit Laub
das volle Glas

12 POINT

8 A 24 a \$3 50

Des Meeres Gewässer
in Bewegung gesetzt

10 POINT

10 A 30 a \$3 25

Preiset unsere Reben
Sagt ein altes Sprichwort
1 2 3 4 5 6 7 8 9 0

8 POINT

14 A 42 a \$3 00

Bildung der Menschen
Nach Regen folgt Sonnenschein
1 2 3 4 5 6 7 8 9 0

SCHWABACHER SERIES

48 POINT

3 A 8 a \$6 95

Pracht = Gebäude

36 POINT

4 A 8 a \$4 50

Elegante Schrift
Hübsche blaue Farben

30 POINT

5 A 10 a \$3 85

Originelle Novellen
Geschichten und Loblieder

24 POINT

5 A 15 a \$3 15

Tanzschulen
Lustige Knaben

14 POINT

9 A 30 a \$3 20

Schwarze Augen
Bildschöne Zigeunerin

12 POINT

9 A 30 a \$2 35

Berliner Promenaden
Und Anlagen der Umgegend

10 POINT

12 A 40 a \$2 20

Drucksachen für moderne
Zuschneider und alte Duntmköpfe

8 POINT

15 A 50 a \$2 65

Nachrichten aus der Heimath
Glänzende Eröffnung der Ausstellung

6 POINT

15 A 50 a \$1 95

Die Schriften von Johann Gutenberg
Gleich nach der Erfindung der Buchdruckerkunst

1234567890

1234567890

TEUTONIC No 1

36 POINT

5 A 12 a \$9 85

Hochländer in Grönland

30 POINT

6 A 15 a \$8 20

Geheimer Durchgang
Kabelnetz der Stadt Boston

24 POINT

8 A 20 a \$7 00

Mexikanischer Kulturkampf
Die Handelsfrage in Nord-Amerika

18 POINT

10 A 25 a \$6 45

Fingerzähme muntere Papageien
Werthvolle Prachtvögel und Schmetterlinge

14 POINT

12 A 30 a \$6 40

Arbeit und Geld
Regiert die ganze Welt

12 POINT

12 A 30 a \$4 85

Eine Morgenstunde
Hat auch Gold im Munde

10 POINT

15 A 40 a \$4 85

Schätze deine Freunde
Aber beschädige nicht die Feinde

9 POINT

15 A 40 a \$4 30

Ein klarer Kopf und freies
Herz bringt niemals keinen Schmerz

8 POINT

20 A 50 a \$4 80

Aus der schlechtesten Hand
Kann Wahrheit noch mächtig wirken

6 POINT

20 A 50 a \$3 75

Wahrsagerinnen und Gartenschläger
Die Zukunft enthüllt und Rath in allen Sachen

1234567890

1234567890

MODERN TEXT No 2

60 POINT

3 A 6 a \$12 00

Armes Benefiz

48 POINT

4 A 12 a \$14 00

Expeditions - Geschäft

36 POINT

4 A 12 a \$8 40

Berstäubung der Maikäfer

30 POINT

4 A 12 a \$5 95

Fünf Erzählungen aus Indien

24 POINT

8 A 20 a \$6 20

Humoristische
Bilder für Kinder

18 POINT

10 A 25 a \$6 60

Unterhandlung
Zwischen zwei Piraten

14 POINT

10 A 25 a \$4 75

Reise um die Welt
Über Wälder und Länder

12 POINT

10 A 30 a \$4 50

Aussichten in Venedig
Gondelfahrt eines Holländers

10 POINT

15 A 40 a \$4 25

Polirter Fußboden für
Tanzschulen und Schlittschuhläufer
1234567890

8 POINT

15 A 40 a \$4 00

Neue und herzlose Geheimnisse
Eines New-Yorker Polizei-Hauptmanns
1234567890

GERMANIA No 150

36 POINT

3 A 7 a \$6 00

Am Wanderstabe

30 POINT

4 A 10 a \$6 00

Reizende Bigemnerin

24 POINT

5 A 15 a \$5 75

Sehnsucht nach den Alpen

18 POINT

7 A 20 a \$5 10

Asyl für obdachlose Schriftsetzer

16 POINT

8 A 24 a \$4 50

Bequemes Lager

12 POINT

10 A 30 a \$3 90

Prächtige Gebirgsluft

10 POINT

13 A 40 a \$3 70

Praktische Unterhaltung
Wald 123 Felder

9 POINT

14 A 42 a \$3 25

Guter Aufenthalt für Kranke
Schon 45 Geheilt

COMPOSITE SERIES

30 POINT NO 150

6 A 15 a \$6 75

Römerkriege

24 POINT NO 150

8 A 20 a \$5 75

Auerochshörner

18 POINT NO 150

10 A 25 a \$4 25

Teutoburger Schlacht

14 POINT NO 150

10 A 30 a \$3 50

Lagen auf der Bärenhaut

12 POINT NO 150

16 A 50 a \$4 50

Und sie tranken stets noch Eines
1 2 3 4 5 6 7 8 9 0

10 POINT NO 30

15 A 40 a \$2 55

Die Berichte verschiedener Reisenden
1 2 3 4 5 6 7 8 9 0

COMPOSITE CONDENSED

42 POINT

4 A 10 a \$6 00

Schneller Rückzug der Rekruten

30 POINT

5 A 12 a \$4 40

Ein Fortschritt der Kunst und Wissenschaft

18 POINT

10 A 25 a \$4 25

Ausgaben in Taschen-format
1234567890

12 POINT

15 A 40 a \$4 00

Wunderrolle Verbesserungen
Vervollständigung der Druckmaschinen
1234567890

BOLDFACE BORUSSIAN

36 POINT

4 A 7 a \$5 50

Englands auswärtige Politik

24 POINT

6 A 14 a \$4 05

Deutscher Novellenschatz in Wort und Bild

14 POINT

8 A 20 a \$3 70

Ferienfahrten lustiger Brüder in die Thäler der Apenninen

11 POINT

12 A 32 a \$3 10

Alles Wissen ist Stückwerk trotz aller Erfindungen und Entdeckungen der Neuzeit
Kulturbilder aus dem Lande des Halbmondes

8 POINT

14 A 42 a \$3 30

Das Leben ist der Güter höchstes nicht, der Uebel größtes aber ist die Schuld.
Glänzende Aufführung der Meisterwerke deutscher Komponisten im königlichen Opernhause zu Berlin
1234567890

GERMAN TEXT No 2

42 POINT

3 A 6 a \$4 35

Weltbekannter Buchhändler

30 POINT

4 A 10 a \$3 85

Colorirte Menjahrs-Anzeigen
Moderne Krügen und bequeme Cravaten

24 POINT

5 A 15 a \$3 95

Sitten-Bilder
Deutscher Landwirth

18 POINT

7 A 20 a \$3 50

Ein falscher Ritter
Der Steinernen Zeitrechnung

14 POINT

8 A 25 a \$3 45

Hauptstädte Europas
Brünn Berlin Paris Madrid
1234567890

12 POINT

9 A 30 a \$3 00

Lustfahrt nach dem Westen
Fruchtbares Jahr für Ackerbauern
1234567890

TEUTONIC EXTENDED

24 POINT

5 A 12 a \$5 40

Pflanzen ohne Zweige
Amerikanischer Blumengarten

22 POINT

6 A 15 a \$4 95

Gartenlaub
Trockene Blätter
1234567890

14 POINT

8 A 20 a \$3 90

Affen und Katzen
Sand Wald Feld Luft
1234567890

GERMAN GOTHISCH

60 POINT

4 A 10 a \$8 65

Prachtvolles Monument

48 POINT

4 A 10 a \$6 55

Grüne Blume

42 POINT

4 A 10 a \$6 25

Dunkler Ausgang

30 POINT

6 A 15 a \$4 00

Arbeiter ohne Hoffnung

24 POINT

7 A 20 a \$3 40

Herzhaft Dankbar Wahrhaft

18 POINT

8 A 25 a \$3 00

Harren sagen die Wahrheit
Ein Thor ist ein Feind ohne Angst
1234567890

12 POINT

9 A 30 a \$2 60

Freude ist das Ziel des Lebens
Ihr Sinnbild ist eine Seele in zwei Körpern
1234567890

MODERN BLACK No 2

18 POINT

6 A 15 a \$2 95

Merkbare
Schöne Wangen

14 POINT

12 A 20 a \$3 20

Spitzige Nadel
Klein und Scharf

12 POINT

8 A 20 a \$2 50

Unbarmherzige
Schwarze Menschen

10 POINT

10 A 25 a \$2 50

Dörfer in Maine
Freie Heimath für Alle

8 POINT

12 A 40 a \$3 00

Eisernes Dampfschiff
Köstliche Reise durch Texas
1234567890

6 POINT

20 A 50 a \$3 00

Akademische Besprechung
Die Fortsetzung der Untersuchung
1234567890

HEBREW No 1

10 POINT

JOB FONT \$3 60

דְּבָרֵי קִהְלֹת בְּיַד מֶלֶךְ בִּירוּשָׁלַם: הַבַּל הַבָּלִים אָמַר קִהְלֹת
הַבַּל הַבָּלִים הַבַּל הַבָּל: מִה־יִתְרוֹן לְאָדָם בְּכָרְעֵמְלוֹ שִׁיעֵמַל
תַּחַת הַשָּׁמֶשׁ: דוֹר הַלֶּךְ וְדוֹר בָּא וְהָאָרֶץ לְעוֹלָם עִמְדַת: וּזְרַח
הַשָּׁמֶשׁ וּבֹא הַשָּׁמֶשׁ וְאֶל־מְקוֹמוֹ שׁוֹאֵף זְרַח הוּא שֵׁם: הוֹלֵךְ
אֶל־דְּרוֹם וְסוֹבֵב אֶל־צָפוֹן סוֹבֵב וְסוֹבֵב הוֹלֵךְ הַרוּחַ וְעַל־סִבִּיבֹתָיו

9 POINT

JOB FONT \$3 60

דְּבָרֵי קִהְלֹת בְּיַד מֶלֶךְ בִּירוּשָׁלַם: הַבַּל הַבָּלִים אָמַר קִהְלֹת הַבַּל הַבָּלִים הַבַּל הַבָּל:
מִה־יִתְרוֹן לְאָדָם בְּכָל־עֵמְלוֹ שִׁיעֵמַל תַּחַת הַשָּׁמֶשׁ: דוֹר הַלֶּךְ וְדוֹר בָּא וְהָאָרֶץ
לְעוֹלָם עִמְדַת: וּזְרַח הַשָּׁמֶשׁ וּבֹא הַשָּׁמֶשׁ וְאֶל־מְקוֹמוֹ שׁוֹאֵף זְרַח הוּא שֵׁם: הוֹלֵךְ
אֶל־דְּרוֹם וְסוֹבֵב אֶל־צָפוֹן סוֹבֵב וְסוֹבֵב הוֹלֵךְ הַרוּחַ וְעַל־סִבִּיבֹתָיו שֵׁב הַרוּחַ: כֹּל־
הַנְּחָלִים הַלְכִים אֶל־הַיָּם וְהַיָּם אֵינְנו מֵלֵא אֶל־מְקוֹם שֶׁהַנְּחָלִים הַלְכִים שֵׁם הֵם שְׁבִים
לֵלְכַת: כֹּל־הַדְּבָרִים יִגְעִים לֹא־יִוֹכַל אִישׁ לְדַבֵּר לֹא־תִשְׁבַּא עֵין לְרֹאוֹת וְלֹא־תִמְלֵא

8 POINT

JOB FONT \$3 60

דְּבָרֵי קִהְלֹת בְּיַד מֶלֶךְ בִּירוּשָׁלַם: הַבַּל הַבָּקִים אָמַר קִהְלֹת הַבַּל הַבָּקִים הַבַּל הַבָּקִים: מִה־יִתְרוֹן
לְאָדָם בְּכָל־עֵמְלוֹ שִׁיעֵמַל תַּחַת הַשָּׁמֶשׁ: דוֹר הַלֶּךְ וְדוֹר בָּא וְהָאָרֶץ לְעוֹלָם עִמְדַת: וּזְרַח הַשָּׁמֶשׁ
בָּא הַשָּׁמֶשׁ וְאֶל־מְקוֹמוֹ שׁוֹאֵף זְרַח הוּא שֵׁם: הוֹלֵךְ אֶל־דְּרוֹם וְסוֹבֵב אֶל־צָפוֹן סוֹבֵב וְסוֹבֵב הוֹלֵךְ
הַרוּחַ וְעַל־סִבִּיבֹתָיו שֵׁב הַרוּחַ: כֹּל־הַנְּחָלִים הַלְכִים אֶל־הַיָּם וְהַיָּם אֵינְנו מֵלֵא אֶל־מְקוֹם שֶׁהַנְּחָלִים
הַלְכִים שֵׁם הֵם שְׁבִים לֵלְכַת: כֹּל־הַדְּבָרִים יִגְעִים לֹא־יִוֹכַל אִישׁ לְדַבֵּר לֹא־תִשְׁבַּע עֵין לְרֹאוֹת וְלֹא־
תִמְלֵא אֶזֶן מִשְׁמַע: מִה־שִׁהִיָּה הוּא שִׁהִיָּה וּמִה־שִׁנְעֵשָׂה הוּא שִׁיעֵשָׂה וְאֵין כֹּל־חֵדֶשׁ תַּחַת הַשָּׁמֶשׁ

This size supplied with or without accented letters, as required

6 POINT

JOB FONT \$3 60

דְּבָרֵי קִהְלֹת בְּיַד מֶלֶךְ בִּירוּשָׁלַם: הַבַּל הַבָּלִים אָמַר קִהְלֹת הַבַּל הַבָּלִים הַבַּל הַבָּלִים: מִה־יִתְרוֹן
לְאָדָם בְּכָל־עֵמְלוֹ שִׁיעֵמַל תַּחַת הַשָּׁמֶשׁ: דוֹר הַלֶּךְ וְדוֹר בָּא וְהָאָרֶץ לְעוֹלָם עִמְדַת: וּזְרַח הַשָּׁמֶשׁ וּבֹא
הַשָּׁמֶשׁ וְאֶל־מְקוֹמוֹ שׁוֹאֵף זְרַח הוּא שֵׁם: הוֹלֵךְ אֶל־דְּרוֹם וְסוֹבֵב אֶל־צָפוֹן סוֹבֵב וְסוֹבֵב הוֹלֵךְ הַרוּחַ וְעַל־
סִבִּיבֹתָיו שֵׁב הַרוּחַ: כֹּל־הַנְּחָלִים הַלְכִים אֶל־הַיָּם וְהַיָּם אֵינְנו מֵלֵא אֶל־מְקוֹם שֶׁהַנְּחָלִים הַלְכִים
שֵׁם הֵם שְׁבִים לֵלְכַת: כֹּל־הַדְּבָרִים יִגְעִים לֹא־יִוֹכַל אִישׁ לְדַבֵּר לֹא־תִשְׁבַּע עֵין לְרֹאוֹת וְלֹא־תִמְלֵא
אֶזֶן מִשְׁמַע: מִה־שִׁהִיָּה הוּא שִׁהִיָּה וּמִה־שִׁנְעֵשָׂה הוּא שִׁיעֵשָׂה וְאֵין כֹּל־חֵדֶשׁ תַּחַת הַשָּׁמֶשׁ

Vowel accents not supplied unless specially ordered. With the exception of 8 Point, this series is suitable only for classical work

RABBINIC

12 POINT

PER FONT \$11 60
Font weighs 10 lbs

מחיימתי קורין את שמוע צערצית. משעה שהכהנים וככסים לאכול צתרומותן. עד סוף
האשמורה הראשונה דצרי ר' אליאזר. וכתומים תומרים עד חלות. ר"ג תומר עד שיעלה
עמוד השחר. וועשה שצאו צניו וצית המשתה תומרו לו לא קרינו את שמוע. תומר להם

10 POINT

PER FONT \$10 40
Font weighs 8 lbs

לך לך תחרךך ומוולדתך ומוצית תציד תל
הארץ אשר תרדך לתת תותה לך ולצניך כי
שם צחרך הסיח תצרכך ושם תעשך לגוי גדול
ותגדלה שמך ונצרכו צך כל משפחות האדמה

8 POINT

PER FONT \$12 80
Font weighs 8 lbs

צעל כתר כהונה ערך חלק תומר צגמרה מ"ק י"ג תעאי
קריה ליה חילוקה כו. הודעתוך שצעלי הגמרה נכתפכו
צפ"י המלות אשר זכרום חכמי המשנה וקצרה יד שכלם
ואין ידם משנת ומאין הבין הוציאו המלה משמעותה תור
כל המלות הזרות שצאו על יד צערנהארד העסקלצערנ

RUSSIAN No 10

12 POINT

PER LB \$0 66
Smallest font, 25 lbs

Общество Американских Словолитниковъ рекомендуетъ
свой богатый складъ Англійскихъ, Нѣмецкихъ, Грѣче-
скихъ и Еврейскихъ шрифтовъ, сдѣланныхъ изъ самаго
лучшаго матеріала. Печатныя и бумаго-рѣзные машины
наилучшей конструкціи и всякіе типографическіе мате-
ріалы по самымъ дешевымъ цѣнамъ Борисъ Гессельбергъ

ARMENIAN

14 POINT

PER LB \$1 12
Smallest font, 25 lbs

Քաղաքական կացութիւնն ի Հայաստան յոյժ
ծանր է և ճգնաժամական: Հայկական խնդիրն
որ ի բազմաց հետէ դադրած էր զԵւրոպա գրգռելէ

10 POINT

PER LB \$1 30
Smallest font, 25 lbs

կացութիւնն ի Հայաստան յոյժ ծանր է և ճգնաժամական: Հայկական
խնդիրն որ ի բազմաց հետէ դադրած էր զԵւրոպա գրգռելէ, արդէն
անցած է նախնական աստիճաններն և այսօր առարկայն է որոշման
և խորհրդեան Մեծ Պետութեանց: Հայ Լիաստն այսօր կը կանգնի

SMALL FONTS OF PORSON AND HEAVYFACE GREEK

PLAN OF PATENTED GREEK CASE

| | | | | | | | | | | | | | | | | | |
|---|---|---|---|---|---|---|---|---|---|---|---|---|---|---|---|---|---|
| A | B | Γ | Δ | E | Z | H | á | â | ã | ä | å | ã | ä | å | α | η | φ |
| Θ | I | K | Λ | M | N | Ξ | έ | ê | ë | ê | ë | ê | ë | ê | · | · | · |
| O | Π | P | Σ | T | Υ | Φ | ή | î | ï | î | ï | î | ï | î | · | · | · |
| X | Ψ | Ω | ƒ | α | η | φ | ί | î | ï | î | ï | î | ï | î | · | · | · |
| α | β | γ | δ | ε | ζ | η | ó | ò | ó | ò | ó | ò | ó | ò | · | · | · |
| θ | ι | κ | λ | μ | ν | ξ | ύ | ù | ύ | ù | ύ | ù | ύ | ù | · | · | · |
| ο | π | ρ | σ | τ | υ | φ | ώ | ώ | ώ | ώ | ώ | ώ | ώ | ώ | · | · | · |
| Χ | ψ | ω | ς | ρ | ρ | ϕ | · | · | · | · | · | · | · | · | · | · | · |

Price of Greek Case, full size, \$2.00

The want of a small font of Greek type is often felt in printing offices. To meet this need, the American Type Founders Company now puts up small and complete assortments (to include all of the characters used in the largest fonts of Porson Greek), together with a case for same of its own devising. No variations in the assortment or weight of these small fonts will be made. For prices, see specimens. Regular fonts of 50 pounds and upwards will be furnished at pound prices.

Sorts are charged at pound rates in quantities; the minimum charge is 75 cents, net. For school examination papers, paragraphs, quotations, etc., these small fonts will prove most useful.

LIST OF PORSON AND HEAVYFACE GREEK LETTERS AND ACCENTS

| | | | | | | | | | | | |
|------|------|------|-------|-------|-------|-------|-------|-------|--------|-------|-------|
| 1 A | 15 O | 29 ε | 43 ς | 144 ä | 65 ή | 74 ι | 138 ð | 96 ù | 162 ó | KERNS | 116 ´ |
| 2 B | 16 Π | 30 ζ | 44 τ | 55 ä | 66 ή | 75 ð | 139 ð | 97 ù | 163 ó | 103 α | 119 ´ |
| 3 Γ | 17 P | 31 η | 45 υ | 56 ä | 67 ή | 78 ð | 84 ð | 168 ù | 160 ó | 104 ε | 120 ´ |
| 4 Δ | 18 Σ | 32 θ | 46 φ | 166 ä | 68 ή | 79 ð | 87 ó | 169 ù | 161 ó | 105 η | 117 ´ |
| 5 E | 19 T | 33 ι | 47 χ | 140 α | 147 ή | 76 ð | 88 ð | 156 ù | 165 ó | 106 ο | 118 ´ |
| 6 Z | 20 Υ | 34 κ | 48 ψ | 58 é | 148 ή | 77 ð | 89 ó | 157 ù | 164 ó | 107 υ | 122 ´ |
| 7 H | 21 Φ | 35 λ | 49 ω | 59 é | 149 ή | 80 ð | 90 ó | 158 ù | 142 φ | 108 ω | 121 ´ |
| 8 Θ | 22 X | 36 μ | 133 ƒ | 60 é | 150 ή | 81 ð | 92 ó | 98 ù | 101 ρ | 109 α | 126 ´ |
| 9 I | 23 Ψ | 37 ν | 50 á | 61 é | 151 ή | 85 ð | 155 ó | 167 ù | 102 ρ | 110 η | 127 ´ |
| 10 K | 24 Ω | 38 ζ | 51 à | 63 é | 70 ή | 86 ð | 91 ó | 99 ó | POINTS | 111 φ | 134 ´ |
| 11 Λ | 25 α | 39 ο | 52 â | 146 é | 141 η | 82 ð | 154 ó | 136 ó | 129 · | 112 ´ | 135 ´ |
| 12 M | 26 β | 40 π | 143 á | 62 é | 71 ð | 83 ð | 93 ù | 100 ó | 130 ´ | 113 ´ | 125 ´ |
| 13 N | 27 γ | 41 ρ | 54 á | 145 é | 72 ð | 152 ð | 94 ù | 159 ó | 131 ; | 114 ^ | 123 ´ |
| 14 E | 28 δ | 42 σ | 57 ä | 64 ή | 73 ð | 153 ð | 95 ù | 137 ó | 132 - | 115 ´ | 124 ´ |

When ordering sorts quote number as well as letter. No sorts for less than 75 cents, net.

INFORMATION RESPECTING GREEK TYPE

The Greek Alphabet contains twenty-four letters: seventeen consonants and seven vowels. The only duplicate characters are σ and ς, the latter being used as a final letter only. The accents and breathings are:

| | | | | |
|--------------|---------|----------------|---------------------|--------------------|
| ˘ Smooth | ˘ Rough | ˘ Smooth acute | ˘ Rough grave | ˘˘ Diaeresis |
| ˘ Acute | ˘ Grave | ˘ Smooth grave | ˘ Smooth circumflex | ˘˘ Diaeresis acute |
| ˘ Circumflex | | ˘ Rough acute | ˘ Rough circumflex | ˘˘ Diaeresis grave |

The sign of interrogation is made by a [?], the colon by an inverted full point [·]; the other points are the same as in English. The kerned letters are seldom required, and are only supplied to a font to make up any deficiency in accented sorts. Accented caps have the accent before them, thus [˘Ω]. The figures used are the same as in English, and are not put up with job fonts.

Compositors should bear in mind that no accent can be placed over any other than one of the last three syllables of a word. The grave accent never occurs but on the last syllable; this being the case, the rough grave [˘] and smooth grave [˘] can only be used for a few monosyllables. No vowels can have a breathing excepting at the beginning of the word, and ρ is the only consonant marked by a breathing. Almost every word has an accent, but very few more than one.

PORSON GREEK

Porson Greek cast to order in fonts of 50 lbs. and upwards

8 POINT

JOB FONT \$7 50

Τοῦ δ' ἐπιγιγνομένου θέρους αἱ μὲν ἐνιαύσιοι σπονδαὶ διελέλυντο μέχρι Πυθίων· καὶ ἐν τῇ ἐκεχειρίᾳ οἱ Ἀθηναῖοι Δηλίου ἀνέστησαν ἐκ Δήλου, ἡγησάμενοι κατὰ παλαιάν τινα αἰτίαν οὐ καθαρὸς ὄντας ἱερῶσθαι, καὶ ἅμα ἔλλιπες σφίσις εἶναι τοῦτο τῆς καθάρσεως, ἣ πρότερόν μοι δεδήλωται ὡς ἀνελόντες τὰς θήκας τῶν τεθνεώτων ὀρθῶς ἐνόμισαν ποιῆσαι. καὶ οἱ μὲν Δηλίοι Ἀτραμύττειον Φαρνάκου δόντος αὐτοῖς ἐν τῇ Ἀσίᾳ ᾤκησαν, οὕτως ὡς ἕκαστος ὄρητο. Κλέων δὲ Ἀθηναίους πείσας ἐς τὰ ἐπὶ Θράκης χωρία ἐξέπλευσε μετὰ τὴν ἐκεχειρίαν, Ἀθηναίων μὲν ὀπλίτας ἔχων διακοσίους καὶ χιλίους καὶ ἰππέας τριακοσίους, τῶν δὲ ξυμμάχων πλείους, ναῦς δὲ

8 Point Porson Greek cast on 9 Point to order in fonts of 50 lbs. and upwards

10 POINT

JOB FONT \$7 50

Ἄλλο δὲ στράτευμα αὐτῷ συνελέγετο ἐν Χερρονήσῳ τῇ καταντιπέρας Ἀβίδου τόνδε τὸν τρόπον. Κλέαρχος Λακεδαιμόνιος φυγὰς ἦν· τούτῳ συγγενόμενος ὁ Κῦρος ἡγάσθη τε αὐτὸν καὶ δίδωσιν αὐτῷ μυρίους δυρεϊκοῦς. ὁ δὲ λαβὼν τὸ χρυσοῖο στράτευμα συνέλεξεν ἀπὸ τούτων τῶν χρημάτων, καὶ ἐπολέμει ἐκ Χερρονήσοι ὀρμώμενος τοῖς Θπαξὶ τοῖς ὑπὲρ Ἑλλησποντον οἰκοῦσι, καὶ ὠφέλει τοὺς Ἑλληνας. ὥστε καὶ χρήματα συνεβάλλοντο αὐτῷ εἰς τὴν τροφήν τῶν στρατιωτῶν αἱ Ἑλλησποντιακαὶ πόλεις ἐκούσαι. τοῦτο δ' αὖ οὕτω τρεφόμενον ἐλάνθανεν αὐτῷ τὸ στράτ-

11 POINT

JOB FONT \$7 50

Ἐπεὶ δὲ ἦσαν ἐν τῇ ἄνω χώρα οἱ Ἑλληνες, ὅποια τῶν χωρίων τοῖς Δρίλαις ἀλώσιμα εἶναι ἐδόκει, ἐμπιπράντες ἀπήεσαν· καὶ οὐδὲν ἦν λαμβάνειν, εἰ μὴ ὕς ἢ βοῦς ἢ ἄλλο τι κτήνος τὸ πῦρ διαπεφευγός. Ἐν δ' ἦν χωρίον μητρόπολις αὐτῶν· εἰς τοῦτο πάντες συνεβλήθησαν. Περὶ δὲ τοῦτο ἦ χαράδρα ἰσχυρῶς βαθεῖα, καὶ πρόσοδοι χαλεπία πρὸς τὸ χωρίον. Κοτυωρίτας δέ, οὓς ὑμετέρους φατ' εἰνανεῖε, τι αὐτῶν εἰλήφμεν, αὐτοὶ

12 POINT

JOB FONT \$7 50

Ἄλλὰ γὰρ οὐ τὰ μέλλοντα ἔσσεσθαι βούλομαι λέγειν, πραχθέντα ὑπὸ τούτων οὐ δυνάμενος εἰπεῖν· οὐδὲ γὰρ ἀπώλεσε. τιμώμενος δὲ καὶ τῶν μεγίστων ἀξιούμενος, αὐτὸς ἐπαγγειλάμενος σώσειν τὴν πόλιν αὐτὸς ἀπώλεσε, φάσκων τὴν πράγμα ἡύρηκεναι μέγα καὶ πολλοῦ ἄξιον. ὑπέχετο δὲ εἰρήνην ποιήσειν μήτε ὄμηρα δούς μήτε τὰ τεῖχη καθελὼν μήτε τὰς ναῦς παραδούς· ταῦτα δὲ εἰπεῖν

GREEK TYPE

12 POINT

Smallest font, 15 lbs

PER LB \$1 16

Καὶ οἱ μὲν ἀμφὶ τὸν Κῦρον, δειπνοποιησάμενοι καὶ φύλακας καταστησάμενοι, ὕπερ ἔδει, ἐκοιμήθησαν. Κροῖσος μέντοι εὐδὺς ἐπὶ Σάρδεων ἔφηνυγε σὺν τῷ στρατεύματι τὰ δ' ἄλλα φύλα ὅποιοι ἐδύνατο προσωτάτω ἐν τῇ νυκτὶ τῆς ἐπ' οἶκον ὁδοῦ ἕκαστος ἀπεχώρει. Ἐπεὶ δὲ ἡμέρα ἐγένετο, εὐδὺς

ἀείμνηστος (μιμνήσκω) ever-memorable ; ἀεκούσιος (ἐκούσιος) involuntary ; ἀθανασία, immortality ; Ἀθῆναι, ὦν, αἶ, Athens ; Ἀθηναίη, Ἀθηνᾶ ; ἀδλητής, contend ; ἀδροίζω, assemble ; ἀδρός, full ; ἀδυμέω, dejected ; αἶγανέα, javelin ; αἶγειρος, poplar ; Αἶγινα, Ægina ; Αἴγυπτος, Egypt ;

11 POINT

Smallest font, 15 lbs

PER LB \$1 22

δ' ἐγένετο πρὸς τῷ τείχει τῷ ἐν Σάρδεσι, τάς τε μηχανὰς ἀνίστη, ὡς προσβαλῶν πρὸς τὸ τεῖχος, καὶ κλίμακας παρεσκευάζετο. Ταῦτα δὲ ποιῶν, κατὰ τὰ ἀποτομώτατα δοκῶντα εἶναι τοῦ Σαρδιανῶν ἐρύματος τῆς ἐπιούσης νυκτός ἀναβιβάζει Χαλδαίους τε καὶ Πέρσας. Ἠγήσατο δ' αὐτοῖς ἀνὴρ Πέρσης, δοῦλος γεγεννημένος τῶν ἐν τῇ ἀκροπόλει τινὸς φρουρῶν, καὶ καταμεμαθηκὸς

αἰδώς, shame ; αἰετός for ἀετός ; αἰθάλη, ashes ; αἰκία, suffering ; αἶλνος, wailing ; αἵματώ, stain with blood ; αἶνγμα, enigma ; αἶνγματωδῶς, obscure ; αἶνυμαι, to take ; αἰπύς, high ; αἰρέω, to kill ; αἰσθάνομαι, to perceive ; αἰσχος, disgrace ; αἰσχροκέρδεια, love of lucre ; αἰσχροός, shameful ; αἰσχύνῃ, shame ; αἰτιάομαι, to accuse ; αἰχμάλωτος, captive ;

10 POINT No 2

Smallest font, 15 lbs

PER LB \$1 30

βασιν τὴν αὐτήν. Ὡς δὲ ἐγένετο τοῦτο δῆλον, ὅτι εἶχετο τὰ ἄκρα, πάντες δὲ ἔφηνον οἱ Λυδοὶ ἀπὸ τῶν τειχῶν, ὅπη ἠδύνατο ἕκαστος τῆς πόλεως. Κῦρος δὲ ἄμα τῇ ἡμέρᾳ εἰσῆει εἰς τὴν πόλιν, καὶ παρήγγειλεν ἐκ τῆς τάξεως μηδένα κινεῖσθαι. Ὁ δὲ Κροῖσος, κατακλεισάμενος ἐν τοῖς βασιλείοις, Κῦρον ἐβόα· ὁ δὲ Κῦρος τοῦ μὲν Κροίσου φύλακας κατέλιπεν, αὐτὸς δὲ ἀπαγαγὼν πρὸς τὴν ἐχομένην ἄκραν, ὡς εἶδε τοὺς μὲν Πέρ-

ἀέστρα, a needle ; ἀκήρατος, incorrupt ; ἀκίς, infirm ; ἀκίνδυνος, free from danger ; ἀκινδύως, to be safe ; ἀκίνητος, immovable ; ἀκμήν, as yet ; ἀκοίτης, husband ; ἀκόλαστος, a profligate ; ἀκολουθέω, to imitate ; ἄκος, healing ; ἀκούω, to hear ; ἀκροόομαι, to obey ; ἀκρόασις, audibility ; ἄκρος, lofty ; ἀκρωτήριον, summit ; ἀκύμων, waveless ; ἀλαζών, bragging ; Ἀλαί, Alæ ; ἀλάομαι, to wander ; ἀλαπύς,

GREEK TYPE

8 POINT NO 2

Smallest font, 15 lbs

PER LB \$1 60

δεδραμήκεσαν γὰρ ἄρπασόμενοι τὰ ἐκ τῶν οἰκίων,) εὐνὴς συνεκάλεσεν αὐτῶν τοὺς ἄρχοντας, καὶ εἶπεν αὐτοῖς ἀπιέναι ἐκ τοῦ στρατεύματος ὡς τάχιστα. "Οὐ γὰρ ἄν," ἔφη, "ἀνασχοίμην πλεονεκτοῦντας ὄρων τοὺς ἀτακτοῦντας. Καὶ εὖ μὲν," ἔφη, "ἐπίστασθε, ὅτι παρεσκευαζόμεν ἐγὼ ὑμᾶς τοὺς ἐμοὶ συστρατειομένους πᾶσι Χαλδαίοις μακαριστοὺς ποιῆσαι· νῦν δ'," ἔφη, "μὴ θαναμάζετε, ἦν τις καὶ ἀπιούσιν ὑμῖν κρείττων ἐντύχη." Ἀκούσαντες ταῦτα οἱ Χαλδαῖοι ἐδεδείσαν τε καὶ ἰκέτερον παύσασθαι ὀργιζόμενον, καὶ τὰ χρήματα πάντα ἀποδώσειν ἔφασαν. Ὁ δὲ εἶπεν, ὅτι οὐδὲν αὐτῶν δέοιτο. "Ἄλλ' εἰ με," ἔφη, "βοίλευσθε παύσασθαι ἀχθόμενοι, ἀπόδοτε πάντα, ὅσα ἐλαβετε, τοῖς διαφυλάξασι

ἄλιεύς, fisherman; ἀλίζω, to salt; ἄλιος, marine; ἀλίσκω, to capture; Ἀλκιβιαδῆς, Alcibiades; ἄλλα, however; ἄλλασσω, to change; ἀλλὰ, otherwise; ἀλλή, elsewhere; ἀλλήλων, one another; ἀλλόκοτος, monstrous; ἄλλος, other; ἀλλόφυλος, foreign; ἄλμη, brine; ἄλμυρός, salt; ἄλογος, irrational; ἄλωπηξ, fox; ἄμαθής, ignorant; ἄμαξιτός, highway; ἄμαρτανω, to err; ἄμαω, to mow; ἄμβολας, mound; ἀμείβω, to pass; ἀμέλγω, to milk; ἀμέλει, truly; ἀμελής, careless; ἀμέμπτως, blamelessly; ἀμεννός, enfeebled; ἀμέτρητος, unmeasured; ἀμετρος, immense; ἀμιλλὰ, strife; ἀμιλλαομαι, endeavor; ἀμνημονέω, to for-

7 POINT NO 2

Smallest font, 10 lbs

PER LB \$1 80

πάντα μοι καλῶς ἔξει. Οἱ μὲν δὴ Χαλδαῖοι οὕτως ἐποίησαν, ὡς ἐκέλευσεν ὁ Κύρος· καὶ ἔλαβον οἱ πειθόμενοι πολλὰ καὶ παντοῖα χρήματα. Ὁ δὲ Κύρος καταστρατοπεδεύσας τοὺς ἑαυτοῦ, ὅπου ἐδόκει ἐπιτηδειότατον εἶναι τῆς πόλεως, μένειν ἐπὶ τοῖς ὅπλοις παρήγγειλε καὶ ἀριστοποιεῖσθαι. Ταῦτα διαπραξάμενος, ἀγαγεῖν ἐκέλευσεν αὐτῷ τὸν Κροῖσον. Ὁ δὲ Κροῖσος ὡς εἶδε τὸν Κύρον, Χαῖρε, ὦ δέσποτα, ἔφη· τοῦτο γὰρ ἢ τύχη καὶ ἔχειν τὸ ἀπὸ τοῦδε δίδωσί σοι, καὶ ἐμοὶ, προσαγορεύειν. Καὶ σὺ γε, ἔφη, ὦ Κροῖσε· ἐπέπερ ἄνθρωποι ἐσμέν ἀμφοτέροι. Ἄτὰρ, ἔφη, ὦ Κροῖσε, ἄρ' ἄν τί μοι ἐθελήσῃς συμβουλευθεῖσαι; Καὶ βουλοίμην γ' ἄν, ἔφη, ὦ Κύρε, ἀγαθὸν τί σοι εὐρένι· τοῦτο γάρ ἄν οἶμαι ἀγαθὸν κάμοι γενέσθαι. Ἀκουσόν τούτων, ἔφη, ὦ Κροῖσε· ἐγὼ γὰρ ὄρων τοὺς στρατιώτας πολλὰ

ἀμφιθαίνω to surround; ἀμφίβολος ambiguous; ἀμφιγνώσσω to feel doubtful; ἀμφικρύπτω to envelope; ἀμφίπολος domestic; ἀμφισβητέω to wrangle; ἀμφιφορεὺς amphora; ἄμφω, ἀμφοῖν the two; ἄμωμος spotless; ἀναβαίνω to ascend; ἀναβάλλω to put off; ἀνάβασις peregrination; ἀναβιώω resuscitate; ἀναβλέπω behold; ἀναγιγνώσκω recognize; ἀναγκάζω oblige; ἀναγκαῖος necessary; ἀνάγκη unavoidable; ἀναγωγή departure; ἀναδέω to bind; ἀναδίδωμι yield up; ἀναδιπλώω to fold over; ἀναδύομαι to shrink; ἀναθάλλω cherish; ἀνάθημα gift; ἀναμιόσαρκος bloodless; ἀναίνομαι to disavow; ἀναίρεσις removal; ἀναίρέω demolish; ἀναίσχυντος shameless; ἀνακαίω to burn; ἀνακαλύπτω to unveil; ἀνάκειμαι recline; ἀνακλαίω to lament; ἀνάκλη-

6 POINT NO 2

Smallest font, 10 lbs

PER LB \$2 00

στρατιώτας. Γιγνώσκω γὰρ, ἔφη, ὅτι, εἰ μὴ τίνα καρπὸν λήψονται τῶν πόνων, οὐ δυνήσομαι αὐτοὺς πολὺν χρόνον πειδομένους εἶναι. Διαρπάσαι μὲν οὖν αὐτοῖς ἐφέμειναι τὴν πόλιν οὐ βούλομαι· τὴν τε γὰρ πόλιν νομίζω ἂν διαφθαρήναι, ἐν τε τῇ ἄρπαγι, εὐ οἶδ' ὅτι οἱ πονηρότατοι πλεονεκτήσεται ἄν. Ἀκούσας ταῦτα ὁ Κροῖσος ἔλεξεν, Ἄλλ' ἐμὲ, ἔφη, ἔασον λέξαι, πρὸς οὓς ἂν ἐγὼ Λυδῶν ἐθέλω, ὅτι διαπέπραγμαί παρὰ σοῦ μὴ ποιῆσαι ἄρπαγην, μηδὲ ἔασαι ἀφανισθῆναι παῖδας καὶ γυναῖκας· ὑπεσχόμεν δέ σοι ἀντι τούτων, ἢ μὴν παρ' ἐκόντων Λυδῶν ἔσονται πάν, ὅ τι καλὸν ἀγαθὸν ἐστίν ἐν Σάρδεσιν. Ἦν γὰρ ταῦτα ἀκούσωσιν, οἶδ' ὅτι ἤξει σοι πάν, ὅ τι ἐστίν ἐνθάδε καλὸν κτήμα ἀνδρῶν καὶ γυναικῶν· καὶ ὁμοίως εἰς νέωτα πολλῶν καὶ καλῶν πάλιν σοι πλήρης ἡ πόλις ἐσται. Ἦν δὲ διαρπάσῃς, καὶ αἱ τέχναι σοι, ἄς πηγὰς φασὶ τῶν καλῶν εἶναι, διεφθαρμέναι ἔσονται. Ἐξέσται δέ σοι ἰδόντι ταῦτα ἐλθόντα ἔτι καὶ περὶ

ἀναλογίζομαι reflect; ἀναλύω to solve; ἀναμένω expect; ἀνάμερος rude; ἀναμιμνήσκω recollect; ἀνάμνησις recollection; ἀναμφισβήτητος indubitable; ἀνανδος effeminate; ἀναξ king; ἀνάξιος unworthy; ἀναπάλλω shake; ἀνάπαυσις rest; ἀναπαύω refresh; ἀναπειθῶ to convince; ἀναπέμψω to send; ἀναπηδάω leap out; ἀναπλάσσω to form; ἀναπλέω return; ἀνάπλεως filled up; ἀναπνέω take breath; ἀναπνοή breathing; ἀναρθρος feeble; ἀναριθμέω count; ἀνάριθμος numberless; ἀναρχία anarchy; ἀνάσσω command; ἀνάστασις departure; ἀνάστατος torn up; ἀναστενάζω to sob; ἀναστρέφω to turn; ἀνατέλλω to rise; ἀνατίθημι to dedicate; ἀνατινάσσω to fling up; ἀνατρέπω subvert; ἀνατρέφω to nourish; ἀνατρέχω run again; ἀναφεύγω to flee; ἀναφυσάω to exhale; ἀναχωρέω to recede; ἀναχώρησις retreat; ἀνδραγαθία valor; ἀνδραποδίζω to enslave

We also make 9 Point and 4½ Point, to order only

HEAVYFACE GREEK

Heavyface Greek cast to order in fonts of 50 lbs. and upwards

8 POINT

JOB FONT \$7 50

Οὐκοῦν οὐδ' ἂν εἰς ἀντίποι ὡς οὐ συμ-
φέρει τῇ πόλει καὶ Λακεδαιμονίους ἀσ-
θενεῖς εἶναι καὶ Θηβαίους τούτουςι. Ἔστι
τοίνυν ἔν τινι τοιούτῳ καιρῷ τὰ πράγ-
ματα νῦν εἴ τι δεῖ τοῖς εἰρημένοις πολλάκις
παρ ὑμῖν λόγοις τεκμήρασθαι, ὥστε Θη-
βαίους μὲν Ὀρχομενοῦ καὶ Θεσπιῶν καὶ
Πλαταιῶν οἰκισθεισῶν ἀσθενεῖς γενέσθαι,
Λακεδαιμονίους δέ, εἰ ποιήσονται τὴν
Ἀρκαδίαν ὑφ' ἑαυτοῖς καὶ Μεγάλην πόλιν

κτείνω, f. κτενῶ (§120, 1), a. ἔκτεινα (§121),
pf. ἔκτανον (§109, 3) (ἀποκτείνω is gen-
erally used), to kill.

Κτησίας, -ου, (ὁ), *Ctesias*, a Greek physi-
cian at the Persian court.

Κύδνος, -ου, (ὁ), *Cydnus*, a river in Cilicia,
flowing through the city of Tarsus.

κύκλος, -ου, (ὁ), a circle; κύκλω, in a circle.

Eng. CYCLE.

κυκλῶω, (ῶ), f. -ώσω, to encircle, surround.

11 POINT

JOB FONT \$7 50

Βοηθήσαντες δὲ ἐς αὐτὸ Πασιτελίδας τε ὁ Λακεδαιμόνιος ἄρχων
καὶ ἡ παροῦσα φυλακὴ προσβαλήντων τῶν Ἀθηναίων ἡμύνοντο. καὶ
ὡς ἐβιάζοντο καὶ αἱ νῆες ἅμα περιέπλεον ἐς τὸν λιμένα περιπεμφθεῖσθαι,
δείσας ὁ Πασιτελίδας μὴ αἶ τε νῆες φθάσωσι λαβοῦσαι ἐρήμον τὴν πόλιν
καὶ τοῦ τειχίσματος ἀλισκομένου ἐγκαταληφθῆ, ἀπολιπὼν αὐτὸ δρόμῳ
ἐχώρει ἐς τὴν πόλιν. οἱ δὲ Ἀθηναῖοι φθάνουσιν οἷ τε ἀπὸ τῶν νεῶν
ἐλόντες τὴν Τωρώνην καὶ ὁ πεζὸς ἐπισπόμενος αὐτοβοεῖ κατὰ τὸ

INSCRIPTION GREEK

10 POINT

30 A \$4 80

ΡΗΞΑΝΤΑΨΙΡΑΦΥΛΑΞΑΝΤΑ
ΠΑΝΛΥΡΑΦΥΛΑΞΑΝΤΑ
ΤΑΜΙΕΥΞΑΝΤΑΔΕΚΑΠΦΤΞΥΞΑΝΤΑ
ΓΡΑΜΜΑΤΕΥΞΑΝΤΑΚΑΙΤΗΓΦΙΛΟΞΕΒΑΣΤΟΥ
ΓΕΡΟΥΞΙΑΞΚΑΙΤΩΝΦΙΛΟΞΕΒΑΣΤΩΝ
ΝΕΨΗΝΚΑΙΡΩΛΑΙΨΗΝΥΠΟΞΧΟΜΕΝΟΝ
ΚΑΙΕΙΖΤΗΝΑΛΟΡΑΝΚΙΟΝΑΣΕΙΚΟΣΙ

GREEK LETTERS

30 CTS EACH

Order by name and number

| | | | | | | | | | | | |
|--------|-------|-------|-----|-------|-------|----|-----|----|-------|--------|-------|
| 1 | 2 | 3 | 20 | 21 | 22 | 23 | 24 | 25 | 26 | 27 | 28 |
| Λ | Σ | Ω | Ψ | Σ | Γ | Ξ | Φ | Π | Θ | Λ | Ω |
| Lambda | Sigma | Omega | Psi | Sigma | Gamma | Xi | Phi | Pi | Theta | Lambda | Omega |

PART XIV.

MISCELLANEOUS

MUSIC TYPE

Mail-List Type Time-Table Figures

SIGNS of all Kinds

Superior and Inferior Letters and Figures

Fractions and Piece Fractions

CALENDARS

Signal Flags and Weather Indicators

Chessmen and Checkers

Gard Pips Gard Indicators Whist Markers

Recipe Marks

Five-Pointed Stars Maltese Crosses

Metal Braces and Dashes

Angular Quads Circular Quads Corner Quads

Metal Furniture

Labor-Saving Leads and Slugs

MAIL-LIST LOGOTYPES

10 POINT EM SET NO 122 ^E

Jan Feb Mar Apr May Jne July Aug Sep Oct Nov Dec
 00 Mr Mrs Miss Box Dr Rev Esq 01

10 POINT EN SET NO 123 ^E

Jan Feb Mar Apr May Jun Jul Aug Sep Oct Nov Dec
 Mr Mrs Miss Box Dr Rev Hon Eld Gen Maj Col 01 02 03

10 POINT EM SET NO 120 ^E

Jan Feb Mar Apr May Jun Jul Aug Sep Oct Nov Dec

10 POINT EN SET NO 114 ^D

Jan Feb Mar Apr May Jun Jul Aug Sep Oct Nov Dec
 Dec Box Mrs Miss Rev Due

9 POINT EN SET NO 150 ^F

Jan Feb Mar Apr May Jun Jul Aug Sep Oct Nov Dec

8 POINT EM SET NO 150 ^F

Jan Feb Mar Apr May Jun Jul Aug Sep Oct Nov Dec
Cast also on 9 Point em set body

10 POINT EN SET NO 121 ^E *Figures on 4-to-em set*

Jan Feb Mar Apr May Jne July Aug Sep Oct Nov Dec
 1900 1901 Miss Mrs Hon 1234567890 Rev Dr Box 1902 1903

10 POINT NO 124 ^E Wis SDak Kan.
 Ill Mo Neb. Iowa Mich Ind

*Sold at Roman Prices. These Logotypes may be used with
 any Series of Mail List Type*

TIME-SAVING MAIL LIST TYPE

| Example, used without Logotypes | Example, in combination with Mail List Logotypes 10 Point No. 122 |
|--|---|
| Theo.L.DeVinne 12Jan92 NEW YORK, N. Y. | Dr Chauncey Depew 3 Mar 91 |
| J. S. Cushing 30Mar72 BOSTON, MASS. | Mrs Mary Walker 31 Oct 00 |
| Sherman Bros. 11Sep73 PHILADELPHIA, PA. | Mr James J. Corbett 3 Jan 96 |
| Pope Bicycle Co. 6Aug95 HARTFORD, CONN. | Rev Abe Slupsky 30 Nov 98 |
| Bureau of Engraving, WASHINGTON, D. C. | James J. Blaine 3 Feb 02 |
| | Theo. Roosevelt 4 Apr 79 |
| | Miss B. Hesselberg 3 Dec 01 |
| | Dr Dora Bloomer 12 May 95 |

Every character is cast on en-quad set, and only en-quads and 4-to-em spaces are used for spacing. By setting sticks to a multiple of 10 Point, spacing and justification become mere child's play; in fact, this type is self-spacing. Although the face is large, on examination it will be found that Time-Saving Mail List Type is quite as condensed on the average as ordinary Mail List Type. Price, same as for 10 Point Roman

MAIL LIST SPECIMENS

| 10 Point No. 67 Roman in combination with Mail List Logotypes 10 Point No. 114 and 10 Point Clarendon No. 120 | 10 Point No. 67 Roman in combination with Mail List Logotypes 10 Point No. 121 and 10 Point Gothic Condensed No. 128 |
|---|--|
| CORNCOB GULCH | N MANCHESTER MICH |
| Miss Anna Mosity 6 May 01 | John Browndie 30 Sep 1900 |
| Rev B Patient Due 25 Nov 98 | Hon M P Radicals 12 Mar 91 |
| Box No 1327 25 Feb 93 | Miss Tilda Williamson 22 July 96 |
| SAN JUAN PORT | Dr Welland Strong 15 Oct 1904 |
| Joseph Andrews Due 3 Sep 97 | RUSSIANVILLE IND |
| Ms Hannah Bates 4 Jul 03 | Miss Annie Laurie 11 Jne 85 |
| Newman Noggs Due 23 Aug 89 | Rev John Partrickson 8 Oct 1901 |
| Ms Fanny Squeers 25 Dec 02 | Dr M D Curemall 13 Jne 94 |

A complete font for 1000 single-line names, as above, will weigh as follows:—Roman, including Spaces and Quads, 75 lbs.; Clarendon No. 120, or Gothic Condensed No. 128, Caps, 10 lbs.; Abbreviations, 4½ lbs. Where Counties and States are added (not using Clarendon or Gothic) from 25 to 50 lbs. of extra sorts and quads would be required, for which a special sort-order must be sent

EXCELSIOR MUSIC

PER LB \$3 60
Weight of smallest font, 15 lbs

THE STAR-SPANGLED BANNER

FRANCIS SCOTT KEY. 1814

Voices in unison

Oh, say, can you see, by the dawn's early light, What so proud-ly we hail'd at the

twilight's last gleaming, Whose stripes and bright stars, thro' the perilous fight, O'er the ramparts we

EXCELSIOR MUSIC No 2

PER LB \$3 60
Weight of smallest font, 15 lbs

MY COUNTRY! 'TIS OF THEE

SAMUEL F. SMITH

H. CAREY

My country! 'tis of thee, Sweet land of lib - er - ty, Of thee I sing; Land where my

fa - thers died! Land of the Pilgrims' pride! From ev - 'ry mountain side Let free-dom ring!

EXCELSIOR MUSIC No 3

PER LB \$3 60
Weight of smallest font, 15 lbs

OLD HUNDRED

Novello, or English Note

ISAAC WATTS

G. FRANC

Be - fore Je - ho - vah's aw - ful throne, Ye na - tions! bow with sa - cred joy:

DIAMOND MUSIC No 1

PER LB \$3 20
Weight of smallest font, 30 lbs

HOME, SWEET HOME

BISHOP

With expression

Mid pleasures and pal - a - ces though we may roam, Be it ev - er so

The first system of musical notation for 'Home, Sweet Home' consists of a treble and bass staff in 2/4 time. The treble staff contains the melody with lyrics underneath. The bass staff provides a harmonic accompaniment. The lyrics are 'Mid pleasures and pal - a - ces though we may roam, Be it ev - er so'.

hum - ble, there's no place like home! A charm from the skies seems to hal - low us

The second system of musical notation continues the piece. It includes a *cres.* (crescendo) marking above the treble staff. The lyrics are 'hum - ble, there's no place like home! A charm from the skies seems to hal - low us'.

DIAMOND MUSIC No 2

PER LB \$3 20
Weight of smallest font, 30 lbs

ANNIE LAURIE

SCOTCH BALLAD

Tenderly

Max - wel - ton's braes are bon - nie, Where ear - ly fa's the dew,

The first system of musical notation for 'Annie Laurie' is in 4/4 time. The treble staff has the melody with lyrics. The bass staff has a simple accompaniment. The lyrics are 'Max - wel - ton's braes are bon - nie, Where ear - ly fa's the dew,'.

And 'twas there that An - nie Lau - rie Gave me her prom - ise true,

The second system of musical notation continues the piece. The lyrics are 'And 'twas there that An - nie Lau - rie Gave me her prom - ise true,'.

DIAMOND MUSIC No 3

PER LB \$3 20
Weight of smallest font, 30 lbs

AULD LANG SYNE

ROBERT BURNS

p *Slow*

Should auld acquaint-ance be for-got, And nev-er brought to mind?

Should auld acquaint-ance be for-got, And days of auld lang syne?

DIAMOND MUSIC No 4

PER LB \$3 20
Weight of smallest font, 30 lbs

Novello, or English Note

WATCH ON THE RHINE

WILHELM

Therewells a cry as thun-ders crash, As clash of swords and break-ers dash; To

Rhine, to Rhine, to the Ger-man Rhine, Who will pro-tect thee riv-er mine?

AGATE MUSIC No 3

VIVA L'AMERICA, HOME OF THE FREE

PER LB \$2 40
Weight of smallest font, 30 lbs

H. MILLARD

Marsiale

ff

Ped.

p

Man.

NONPAREIL MUSIC No 3

EVER BE HAPPY

PER LB \$2 00
Weight of smallest font, 30 lbs
BALFE

Allegretto Moderato

mf

MUSIC CASES, PER SET OF THREE, \$3.00

TIME-TABLE FIGURES

3 Point on 6 Point Gothic No. 127 48A \$1.10
 4½ Point on 6 Point Gothic No. 127 42A \$1.25
 5 Point on 6 Point Gothic No. 127 36A \$1.30

4½ Point on 6 Point Figures, 3½ Point set Per lb., \$1.16

| ARRIVES AT NEW YORK | No. 6 DAILY | No. 20 DAILY |
|--|----------------|-----------------|
| CORTLAND STREET . . . | 7 20AM | 2 20PM |
| DESBROSSES STREET . . . | 7 23AM | 2 23PM |
| TWENTY-THIRD STREET . . . | 7 33AM | 2 33PM |
| <i>New York, New Haven & Hartford Railroad</i> | W'K DAYS | SUNDAYS |
| LV NEW YORK | 8 00AM | 10 00AM |
| AR STAMFORD | 8 57AM | 12 22AM |
| AR SOUTH NORWALK | 7 22AM | 12 33AM |
| AR NEW HAVEN | 8 22AM | 12 44AM |

5 Point Roman No. 57 with 5 Point Clarendon
 Time-Table Figures. *Figures all en set*
 Roman, per lb., \$1.20 Clarendon, per lb., \$1.80

| P. M. | A. M. | LV | Ar | P. M. | A. M. |
|-------|-------|-------------------------|-------|-------|-------|
| 10 10 | 9 10 | BURLINGTON | 10 10 | 10 11 | |
| | 9 50 | Latty | | 10 24 | |
| 10 20 | 9 55 | Mediapolis | 10 20 | 10 48 | |
| 10 25 | 10 00 | MORNING SUN | 10 25 | 11 05 | |
| 10 28 | 10 20 | Wapello | 10 35 | 11 25 | |
| 10 38 | 11 05 | COLUMBUS JUNC | 10 40 | 11 45 | |
| 10 45 | 12 20 | NICHOLS | 10 55 | 12 02 | |

5½ Point Roman No. 57 with 5½ Point Clarendon
 Time-Table Figures. *Figures all en set*
 Roman, per lb., \$0.74 Clarendon, per lb., \$1.44

| P. M. | A. M. | LV | Ar | P. M. | A. M. |
|-------|-------|-------------------------|-------|-------|-------|
| 6 30 | 4 20 | BURLINGTON | 10 45 | 8 15 | |
| | | Latty | | | |
| 7 01 | 4 55 | Mediapolis | 9 14 | 7 40 | |
| 7 15 | 5 14 | MORNING SUN | 9 15 | 7 25 | |
| 7 30 | 5 30 | Wapello | 9 16 | 7 15 | |
| 7 51 | 5 55 | COLUMBUS JUNC | 8 17 | 6 52 | |
| 8 20 | 4 25 | NICHOLS | 8 18 | 6 25 | |

6 Point Roman No. 57 with 6 Point Clarendon
 Time-Table Figures. *Figures all en set*
 Roman, per lb., \$0.64 Clarendon, per lb., \$1.16

| A. M. | P. M. | LV | Ar | P. M. | A. M. |
|-------|-------|-------------------------|-------|-------|-------|
| 8 40 | 6 30 | BURLINGTON | 10 45 | 8 15 | |
| 8 58 | | Latty | | | |
| 9 15 | 7 01 | Mediapolis | 10 14 | 7 40 | |
| 9 31 | 7 15 | MORNING SUN | 9 55 | 7 25 | |
| 9 48 | 7 30 | Wapello | 9 40 | 7 15 | |
| 10 15 | 7 51 | COLUMBUS JUNC | 9 15 | 6 52 | |
| 10 50 | 8 20 | NICHOLS | 9 46 | 6 25 | |

5½ Point Antique No. 125 32A 64A \$2.95
 Figures, 4 Point set Per lb., \$1.44

| | | | | |
|---------|--------------|------------------------|----|---------|
| 10 05pm | Ar | Grand Island | Lv | 11 22am |
| 10 00pm | Ar | Crook | Lv | 12 40am |
| 11 44pm | Ar | Sterling | Lv | 12 44am |
| 12 39pm | Ar | Merino | Lv | 11 55am |
| 12 49pm | Ar | Snyder | Lv | 10 04am |
| 2 53pm | Ar | Ft. Morgan | Lv | 10 33am |
| 4 55pm | Ar | Weldon | Lv | 10 45am |
| 4 33pm | Ar | Orchard | Lv | 10 56am |
| 4 36pm | Ar | Hardin | Lv | 10 56am |
| 4 34pm | Ar | Kersey | Lv | 10 58am |

6 Point Antique No. 125 24A 48A \$2.30
 Four-fifth Figures Per lb., \$1.16
Can be cast on 5 Point set if desired

| | | | | |
|---------|--------------|-------------------------|----|---------|
| 10 00pm | Ar | Geneva | Lv | 4 00am |
| 10 12pm | Ar | DeKalb | Lv | 4 05am |
| 10 22pm | Ar | Dixon | Lv | 4 10am |
| 2 45pm | Ar | Boone | Lv | 4 21am |
| 2 55pm | Ar | Jefferson | Lv | 4 50am |
| 2 58pm | Ar | Cedar Rapids | Lv | 4 55am |
| 3 00pm | Ar | Columbus | Lv | 5 45am |
| 3 04pm | Ar | Grand Island | Lv | 5 59am |
| 3 10pm | Ar | Des Moines | Lv | 10 22am |
| 3 24pm | Ar | Missouri Junc | Lv | 10 55am |

5 Point Ionic No. 122 24A 48A \$2.60
 Figures, 4 Point set Per lb., \$1.80

| | | |
|-----|-------------------------------------|---------|
| 759 | Lv. PERU | 12 00pm |
| 797 | Lv. Portland | 12 15pm |
| 799 | Lv. North Manchester | 10 10pm |
| 796 | Lv. Auburn | 1 44pm |
| 797 | Lv. DETROIT | 1 59pm |
| 823 | Lv. Rotterdam Junc | 1 50pm |
| 824 | Lv. NEW YORK (42d Street) | 1 00pm |
| 835 | Lv. Niagara Falls | 2 00pm |
| 844 | Lv. Suspension Bridge | 2 06pm |
| 856 | Lv. Niagara Falls, N. Y | 3 56pm |

6 Point Ionic No. 122 24A 48A \$2.30
 Four-fifth Figures Per lb., \$1.16
Can be cast on 5 Point set if desired

| | | |
|-----|--------------------------------|---------|
| 199 | Lv. PERU | 6 05pm |
| 134 | Lv. Portland | 10 00pm |
| 125 | Lv. North Manchester | 12 30pm |
| 205 | Lv. Auburn | 1 09pm |
| 413 | Lv. Butler | 1 64pm |
| 239 | Lv. Montpelier | 1 06pm |
| 399 | Lv. Adrian | 1 08pm |
| 397 | Lv. DETROIT | 9 28pm |
| 666 | Lv. Windsor | 8 54pm |
| 644 | Lv. Chatham | 9 58pm |

TIME-TABLE LOGOTYPES

| 5 POINT | PER LB., \$2 80 |
|--------------|-----------------|
| 2½ Point set | ¶ † * ‡ § |
| 5 Point set | AM PM AM PM |
| 6 Point set | AM PM AM PM |
| 6½ Point set | am pm |
| 7 Point set | AM PM AR LV |

Can be cast on 5½ Point or 6 Point body or any wider set

| 5½ POINT | PER LB., \$2 40 |
|--------------|-----------------|
| 2¾ Point set | * † ‡ § ¶ |
| 5½ Point set | AM PM |

Can be cast on 6 Point body or any wider set

Order by Name and Number

| 6 POINT | PER LB., \$2 00 |
|--------------|---------------------------|
| 3 Point set | * † ‡ § ¶ |
| 5 Point set | " " |
| 6 Point set | AM PM am pm Lv Ar n't n'n |
| 7½ Point set | am pm |
| 9 Point set | A.M. P.M. |
| 11 Point set | AM PM |
| 12 Point set | am pm n'n n't |
| 18 Point set | A. M. P. M. |

Can be cast any wider set

| 8 POINT | PER LB., \$1 60 |
|--------------|---------------------------|
| 12 Point set | AM PM |
| 18 Point set | A. M. P. M. |
| 12 POINT | PER LB., \$1 16 |
| 32 Point set | DAILY SUNDAY ONLY |
| 18 POINT | PER LB., \$1 00 |
| 32 Point set | DAILY DAILY EXCEPT SUNDAY |

Can be cast any wider set

TIME-TABLE FIGURES

8 POINT WHITEFACE FIGURES NO 151
PER LB. \$1 60

| | | | |
|-------|---------------------------|----|-------|
| 1.00 | Lv. CHICAGO | Ar | 2.46 |
| 4.50 | Ar. Galesburg | Lv | 10.16 |
| 5.35 | Lv. Galesburg | Ar | 10.22 |
| 6.05 | Abingdon | | 9.49 |
| 6.17 | St. Augustine | | 9.37 |
| | Avon | | |
| 6.40 | Prairie City | | 9.22 |
| 6.50 | Bushnell | | 9.12 |
| 7.02 | Bardolph | | 9.02 |
| 7.14 | Macomb | | 8.49 |
| 7.20 | Colchester | | 8.33 |
| 7.31 | Tennessee | | 8.29 |
| 7.46 | Colmar | | 8.22 |
| 8.03 | Plymouth | | 8.12 |

6 POINT WHITEFACE FIGURES NO 152
PER LB. \$3 00

| | | | | | |
|-------|-----|---------------------------|----|-----|-------|
| 7.23 | 0 | Lv. LOUISVILLE | Ar | 123 | 10.15 |
| 7.32 | 74 | Huntington | | 47 | 10.00 |
| 7.43 | 80 | Ferdinand | | 41 | 9.47 |
| 7.59 | 85 | Dale | | 37 | 9.40 |
| 8.07 | 88 | Lincoln | | 33 | 9.28 |
| 8.14 | 91 | Gentryville | | 29 | 9.03 |
| 8.17 | 93 | Pigeon | | 26 | 9.05 |
| 8.22 | 96 | Tennessee | | 22 | 8.53 |
| 8.30 | 201 | De Gonia | | 17 | 8.50 |
| 8.36 | 105 | Boonville | | 13 | 8.42 |
| 8.40 | 114 | Dawson | | 7 | 8.34 |
| 8.55 | 118 | Stevenson | | 4 | 8.20 |
| 11.59 | 122 | Evansville | | 0 | 5.20 |

8 POINT NO 31 LIGHTFACE PER LB. 90 CTS. 8 POINT NO 32 HEAVYFACE

| | | | |
|-------|----------------------------|----|-------|
| 11 48 | Lv. ST. LOUIS | Ar | 3 45 |
| 12 15 | Alton | | 3 10 |
| | Texas Junction | | 2 45 |
| 2 12 | Clarksville | | 1 15 |
| 2 32 | Louisiana | | 12 55 |
| 3 15 | Ar. Hannibal | Lv | 12 12 |
| 3 55 | Lv. Hannibal | Ar | 10 49 |
| 4 42 | Palmyra | | 10 12 |
| 4 59 | Ely | | 9 49 |
| 5 12 | Monroe | | 9 36 |
| 5 25 | Hunnewell | | 9 24 |
| 5 35 | Lakenan | | 9 12 |
| 5 46 | Shelbina | | 8 46 |
| 6 31 | Macon | | 8 22 |

6 POINT NO 31 LIGHTFACE PER LB. \$1 16 6 POINT NO 32 HEAVYFACE

| | | | | | |
|-------|----|------------------------------|----|-----|-------|
| 8 07 | 0 | Lv. LOUISVILLE | Ar | 273 | 5 42 |
| 8 27 | 6 | New Albany | | 267 | 5 22 |
| 8 39 | 12 | Edwardsville | | 261 | 5 07 |
| 8 47 | 15 | Georgetown | | 258 | 4 59 |
| 9 00 | 21 | Crandall | | 252 | 4 47 |
| | 22 | Mott | | 251 | |
| 9 06 | 23 | Corydon Junction | | 249 | 4 43 |
| 9 13 | 26 | Ramseys | | 246 | 4 35 |
| 9 20 | 31 | De Pauw | | 243 | 4 28 |
| 9 31 | 33 | Milltown | | 239 | 4 20 |
| 9 40 | 38 | Marengo | | 235 | 4 11 |
| 9 52 | 42 | Temple | | 238 | 4 02 |
| 10 00 | 45 | English | | 227 | 3 55 |

7 POINT NO 31 LIGHTFACE PER LB. \$1 00 7 POINT NO 32 HEAVYFACE

| | | | |
|-------|----------------------------|----|-------|
| 8 35 | Lv. ST. LOUIS | Ar | 5 20 |
| 8 53 | East St. Louis | | 5 00 |
| 9 35 | Upper Alton | | 4 14 |
| 9 55 | Brighton | | 3 55 |
| 10 05 | Piasa | | 3 43 |
| 10 15 | Medora | | 3 33 |
| 10 45 | Greenfield | | 3 05 |
| 10 55 | Wrights | | 2 53 |
| 11 10 | Whitehall | | 2 39 |
| 11 20 | West Roodhouse | | 2 27 |
| 11 47 | Winchester | | 2 01 |
| 12 01 | Riggston | | 1 49 |
| 12 12 | Chapin | | 1 34 |
| 1 10 | Beardstown | | 1 07 |
| 1 34 | Browning | | 12 46 |
| 2 10 | Vermont | | 12 12 |
| 2 20 | Table Grove | | 11 43 |

5 1/2 POINT NO 31 LIGHTFACE PER LB. \$1 44 5 1/2 POINT NO 32 HEAVYFACE

| | | | | | |
|-------|----|------------------------------|----|-----|-------|
| 8 30 | 0 | Lv. PLEASANT HILL | Ar | 133 | 5 50 |
| 8 52 | 10 | Harrisonville | | 123 | 5 25 |
| 9 23 | 23 | Archie | | 110 | 4 57 |
| 9 36 | 29 | Audrain | | 104 | 4 43 |
| 9 58 | 39 | Butler | | 94 | 4 22 |
| 10 21 | 48 | Ovid | | 85 | |
| 10 26 | 50 | Rich Hill | | 83 | 3 55 |
| 10 40 | 56 | Arthur | | 77 | 3 50 |
| 10 46 | 59 | Horton | | 04 | 3 42 |
| 11 10 | 69 | Nevada | | 64 | 3 36 |
| 11 20 | 71 | Nassau | | 62 | 3 15 |
| 11 25 | 75 | Milo | | 56 | 3 10 |
| 11 35 | 82 | Sheldon | | 51 | 3 05 |
| 11 52 | 87 | Irwin | | 46 | 2 55 |
| 12 03 | 94 | Lamar | | 39 | 2 38 |

5 POINT NO 31 LIGHTFACE PER LB. \$1 80 5 POINT NO 32 HEAVYFACE

| | | | | | |
|-------|----|------------------------------|----|-----|------|
| 10 10 | 0 | Lv. KANSAS CITY | Ar | 760 | 5 45 |
| 10 17 | 1 | Grand Avenue | | 759 | 5 38 |
| 10 30 | 6 | Kansas City Junc. | | 754 | 5 25 |
| 10 38 | 8 | Centropolis | | 752 | 5 16 |
| 10 45 | 11 | Leeds | | 749 | 5 09 |
| 11 00 | 18 | Dodson | | 742 | 4 56 |
| 11 10 | 21 | Red Bridge | | 739 | 4 47 |
| 11 19 | 25 | Martin City | | 735 | 4 37 |
| 11 25 | 28 | Newington | | 732 | 4 32 |
| 11 42 | 34 | Stillwell | | 726 | 4 20 |
| 11 54 | 39 | Bucyrus | | 721 | 4 02 |
| 11 59 | 43 | Chiles | | 717 | 3 53 |
| 12 08 | 46 | Wagstaff | | 714 | 3 47 |
| 12 25 | 54 | Paola | | 706 | 3 27 |
| 12 42 | 61 | Osawatomie | | 699 | 3 09 |
| 1 00 | 66 | O'Brien | | 694 | 2 50 |

ILLUSTRATIONS AND DEFINITIONS OF SIGNS

| MATHEMATICAL | MATHEMATICAL <i>(Continued)</i> | ECCLESIASTICAL | ASTRONOMICAL <i>(Continued)</i> |
|--------------------------|------------------------------------|--------------------------|------------------------------------|
| + plus | ∴ therefore | ∇ versicle | ♂ Mars |
| - minus | ∵ because | ⊞ response | ♃ Jupiter |
| × into, with | √ radical | ✝ or † sign of the cross | ♄ Saturn |
| ÷ divided by | ° degrees | | ♅ or ♁ Uranus |
| = equality | ' minutes | | ♆ Neptune |
| ± plus or minus | " seconds | | ☾ New Moon |
| □ square | | ASTRONOMICAL | ☽ First Quarter |
| ▭ rectangle | | ♈ Aries | ☾ Full Moon |
| △ triangle | | ♉ Taurus | ☾ Last Quarter |
| ○ circle | | ♊ Gemini | ♋ Conjunction |
| ∠ angle | | ♋ Cancer | ♌ Opposition |
| ⊥ right angle | | ♌ Leo | ♍ Trine |
| ⊃ or ⊃ greater than | | ♍ Virgo | ♎ Quartile |
| ⊂ or < less than | | ♎ Libra | ♏ Sextile |
| ⊥ perpendicular | | ♏ Scorpio | ♐ Dragon's Head |
| ~ difference | | ♐ Sagittarius | ♑ Dragon's Tail |
| ∫ integration | | ♑ Capricornus | ♒ Ceres |
| ≈ equivalency | | ♒ Aquarius | ♓ Pallas |
| ∴ proportion | | ♓ Pisces | ♁ Juno |
| ≐ geometrical proportion | | ☉ or ☼ Sun | ♂ Vesta |
| -: difference, excess | | ♀ Mercury | |
| | | ♁ Venus | |
| | | ♁ or ⊕ Earth | |
| | COMMERCIAL | | |
| | @ at, to | | |
| | Ⓢ per, each | | |
| | lb pound | | |
| | % percentum | | |
| | / shilling | | |
| | ¢ cent | | |
| | ¼ account | | |
| | MEDICAL | | |
| | ℞ recipe, take | | |
| | ℥ ounce | | |
| | ℥ drachm | | |
| | ℥ scruple | | |

MEDICAL SIGNS

No 150 F

12 POINT PER FONT \$1 00

℞ ℥ ℥

11 POINT PER FONT \$1 00

℞ ℥ ℥

10 POINT PER FONT \$1 00

℞ ℥ ℥

9 POINT PER FONT \$1 00

℞ ℥ ℥

8 POINT PER FONT \$1 00

℞ ℥ ℥

7 POINT PER FONT \$1 00

℞ ℥ ℥

6 POINT PER FONT \$1 00

℞ ℥ ℥

COMMERCIAL SIGNS

No 150 F

12 POINT PER LB. \$1 16

Ⓢ @ lb % ¢

11 POINT PER LB. \$1 22

Ⓢ @ lb % ¢

10 POINT PER LB. \$1 30

Ⓢ @ lb % ¢

9 POINT PER LB. \$1 44

Ⓢ @ lb % ¢

8 POINT PER LB. \$1 60

Ⓢ @ lb % ¢

7 POINT PER LB. \$1 80

Ⓢ @ lb % ¢

6 POINT PER LB. \$2 00

Ⓢ @ lb % ¢

5½ POINT PER LB. \$2 40

Ⓢ @ lb % ¢

ARITHMETICAL SIGNS

No 150 F

12 POINT PER FONT \$1 16

+ - × ÷ =

11 POINT PER FONT \$1 22

+ - × ÷ =

10 POINT PER FONT \$1 30

+ - × ÷ =

9 POINT PER FONT \$1 44

+ - × ÷ =

8 POINT PER FONT \$1 60

+ - × ÷ =

7 POINT PER FONT \$1 80

+ - × ÷ =

6 POINT PER FONT \$2 00

+ - × ÷ =

5½ POINT PER FONT \$2 40

+ - × ÷ =

ALGEBRAIC SIGNS No 150

12 POINT PER FONT \$1 16

51 52 53 54 55 56 57

+ - × ÷ = ∴ ±

59 60 61 62 63 64 65

□ △ < √ √ ∴ ∴

66 67

11 POINT PER FONT \$1 22

51 52 53 54 55 56 57

+ - × ÷ = ∴ ±

59 60 61 62 63 64 65

□ △ < √ √ ∴ ∴

66 67

10 POINT PER FONT \$1 30

51 52 53 54 55 56 57

+ - × ÷ = ∴ ±

59 60 61 62 63 64 65

□ △ < √ √ ∴ ∴

66 67

ALGEBRAIC SIGNS No 150—Continued

| 9 POINT PER FONT \$1 44 | | | | | | | | 8 POINT PER FONT \$1 60 | | | | | | | | 7 POINT PER FONT \$1 80 | | | | | | | | | | |
|-------------------------|----|----|----|----|----|----|----|-------------------------|----|----|----|----|----|----|----|-------------------------|----|----|----|----|----|----|----|----|----|----|
| 51 | 52 | 53 | 54 | 55 | 56 | 57 | 59 | 51 | 52 | 53 | 54 | 55 | 56 | 57 | 59 | 60 | 51 | 52 | 53 | 54 | 55 | 56 | 57 | 58 | 59 | 60 |
| + | - | × | ÷ | = | ∴ | ± | □ | + | - | × | ÷ | = | ∴ | ± | □ | △ | + | - | × | ÷ | = | ∴ | ± | □ | □ | △ |
| 60 | 61 | 62 | 63 | 64 | 65 | 66 | 67 | 61 | 62 | 63 | 64 | 65 | 66 | 67 | 61 | 62 | 63 | 64 | 65 | 66 | | | | | | |
| △ | < | √ | ∛ | : | ∴ | ∠ | ∩ | < | √ | ∛ | : | ∴ | ∠ | ∩ | < | √ | ∛ | : | ∴ | ∠ | | | | | | |

| 6 POINT PER FONT \$2 00 | | | | | | | | | | | | 5½ POINT PER FONT \$2 40 | | | | | | | | | | | | | | | | | | | |
|-------------------------|----|----|----|----|----|----|----|----|----|----|----|--------------------------|----|----|----|----|----|----|----|----|----|----|----|----|----|----|----|----|----|----|----|
| 51 | 52 | 53 | 54 | 55 | 56 | 57 | 58 | 59 | 60 | 61 | 62 | 63 | 64 | 65 | 66 | 51 | 52 | 53 | 54 | 55 | 56 | 57 | 58 | 59 | 60 | 61 | 62 | 63 | 64 | 65 | 66 |
| + | - | × | ÷ | = | ∴ | ± | □ | □ | △ | < | √ | ∛ | : | ∴ | ∠ | + | - | × | ÷ | = | ∴ | ± | □ | □ | △ | < | √ | ∛ | : | ∴ | ∠ |

ASTRONOMICAL SIGNS

24 POINT NO 150 SET OF FOUR, 30 CENTS

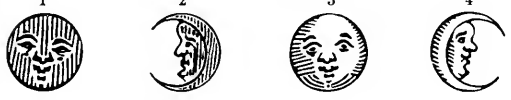

20 POINT NO 150 SET OF FOUR, 30 CENTS



16 POINT NO 150 SET OF FOUR, 25 CENTS



12 POINT NO 153 PER FONT \$3 00



12 POINT NO 152 PER FONT \$3 00



11 POINT NO 152 PER FONT \$3 00



10 POINT NO 152 PER FONT \$3 00



9 POINT NO 152 PER FONT \$2 25

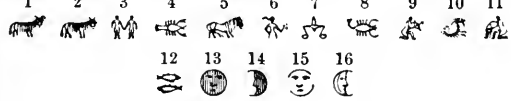

8 POINT NO 152 PER FONT \$2 00

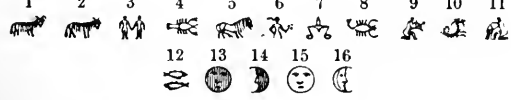

14 POINT NO 151 PER FONT \$5 40

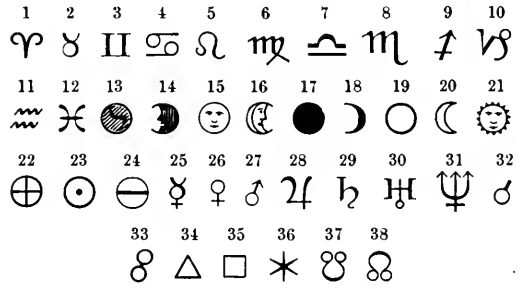

12 POINT NO 151 PER FONT \$4 50

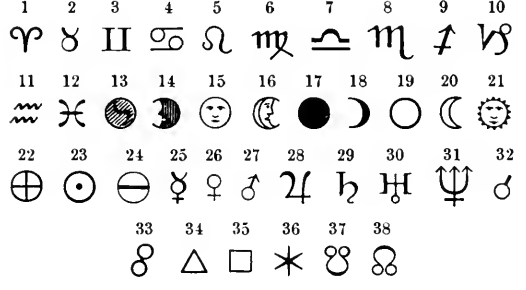

11 POINT NO 151 PER FONT \$4 50

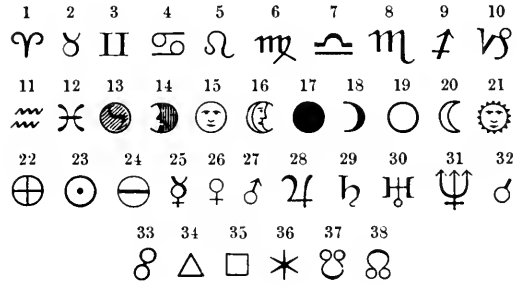

10 POINT NO 151 PER FONT \$4 75

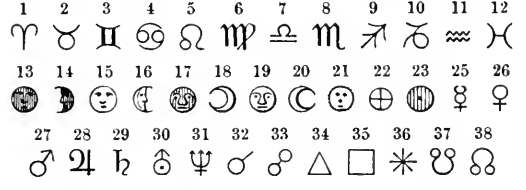

ASTRONOMICAL SIGNS—Continued

9 POINT No 151 PER FONT \$5 00

| | | | | | | | | | | | | | |
|----|----|----|----|----|----|----|----|----|----|----|----|----|----|
| 1 | 2 | 3 | 4 | 5 | 6 | 7 | 8 | 9 | 10 | 11 | 12 | | |
| ♈ | ♉ | ♊ | ♋ | ♌ | ♍ | ♎ | ♏ | ♐ | ♑ | ♒ | ♓ | | |
| 13 | 14 | 15 | 16 | 17 | 18 | 19 | 20 | 21 | 22 | 23 | 24 | 25 | 26 |
| ♁ | ♂ | ♃ | ♄ | ♅ | ♆ | ♇ | ♈ | ♉ | ♊ | ♋ | ♌ | ♍ | ♎ |
| 27 | 28 | 29 | 30 | 31 | 32 | 33 | 34 | 35 | 36 | 37 | 38 | | |
| ♏ | ♐ | ♑ | ♒ | ♓ | ♁ | ♂ | ♃ | ♄ | ♅ | ♆ | ♇ | ♈ | ♉ |

7 POINT No 151 PER FONT \$2 75

| | | | | | | | | | | | | | | |
|----|----|----|----|----|----|----|----|----|----|----|----|----|----|----|
| 1 | 2 | 3 | 4 | 5 | 6 | 7 | 8 | 9 | 10 | 11 | 12 | 13 | 14 | |
| ♈ | ♉ | ♊ | ♋ | ♌ | ♍ | ♎ | ♏ | ♐ | ♑ | ♒ | ♓ | ♁ | ♂ | |
| 15 | 16 | 17 | 18 | 19 | 20 | 21 | 22 | 23 | 24 | 25 | 26 | 27 | 28 | 29 |
| ♃ | ♄ | ♅ | ♆ | ♇ | ♈ | ♉ | ♊ | ♋ | ♌ | ♍ | ♎ | ♏ | ♐ | ♑ |
| 30 | 31 | 32 | 33 | 34 | 35 | 36 | 37 | 38 | | | | | | |
| ♒ | ♓ | ♁ | ♂ | ♃ | ♄ | ♅ | ♆ | ♇ | | | | | | |

8 POINT No 151 PER FONT \$5 00

| | | | | | | | | | | | | | |
|----|----|----|----|----|----|----|----|----|----|----|----|----|----|
| 1 | 2 | 3 | 4 | 5 | 6 | 7 | 8 | 9 | 10 | 11 | 12 | | |
| ♈ | ♉ | ♊ | ♋ | ♌ | ♍ | ♎ | ♏ | ♐ | ♑ | ♒ | ♓ | | |
| 13 | 14 | 15 | 16 | 17 | 18 | 19 | 20 | 21 | 22 | 23 | 24 | 25 | 26 |
| ♁ | ♂ | ♃ | ♄ | ♅ | ♆ | ♇ | ♈ | ♉ | ♊ | ♋ | ♌ | ♍ | ♎ |
| 27 | 28 | 29 | 30 | 31 | 32 | 33 | 34 | 35 | 36 | 37 | 38 | | |
| ♏ | ♐ | ♑ | ♒ | ♓ | ♁ | ♂ | ♃ | ♄ | ♅ | ♆ | ♇ | ♈ | ♉ |

6 POINT No 151 PER FONT \$2 25

| | | | | | | | | | | | | | | | | |
|----|----|----|----|----|----|----|----|----|----|----|----|----|----|----|----|----|
| 1 | 2 | 3 | 4 | 5 | 6 | 7 | 8 | 9 | 10 | 11 | 12 | 13 | 14 | 15 | 16 | |
| ♈ | ♉ | ♊ | ♋ | ♌ | ♍ | ♎ | ♏ | ♐ | ♑ | ♒ | ♓ | ♁ | ♂ | ♃ | ♄ | |
| 17 | 18 | 19 | 20 | 21 | 22 | 23 | 24 | 25 | 26 | 27 | 28 | 29 | 30 | 31 | 32 | 33 |
| ♅ | ♆ | ♇ | ♈ | ♉ | ♊ | ♋ | ♌ | ♍ | ♎ | ♏ | ♐ | ♑ | ♒ | ♓ | ♁ | ♂ |
| 34 | 35 | 36 | 37 | 38 | | | | | | | | | | | | |
| ♒ | ♓ | ♁ | ♂ | ♃ | | | | | | | | | | | | |

PIECE ROOT SIGNS

For making Root Signs of any power. Prices quoted are per pound

| | | | | | |
|----------|--|--------|----------|--|--------|
| 16 POINT | | \$1 08 | 20 POINT | | \$0 94 |
| 8 POINT | | \$1 60 | 10 POINT | | \$1 30 |

MISCELLANEOUS SIGNS

E-F

Cast to order. In ordering Signs, state size and No.

12 POINT NO 150 PER LB. \$1 16

| | | | | | | | |
|-----|-----|-----|-----|-----|-----|-----|-----|
| 908 | 909 | 910 | 911 | 912 | 913 | 914 | 915 |
| ' | ° | # | ∇ | † | ‡ | ‡ | ⊕ |

11 POINT NO 150 PER LB. \$1 22

| | | | | | | |
|-----|-----|-----|-----|-----|-----|-----|
| 901 | 902 | 903 | 904 | 905 | 906 | 907 |
| ' | ° | # | ∇ | † | ‡ | ‡ |

10 POINT NO 150 PER LB. \$1 30

| | | | | | | | |
|-----|-----|-----|-----|-----|-----|-----|-----|
| 893 | 894 | 895 | 896 | 897 | 898 | 899 | 900 |
| ' | ° | # | ∇ | ∇ | † | ‡ | ‡ |

9 POINT NO 150 PER LB. \$1 44

| | | | | | | | | | |
|-----|-----|-----|-----|-----|-----|-----|-----|-----|-----|
| 883 | 884 | 885 | 886 | 887 | 888 | 889 | 890 | 891 | 892 |
| ' | ° | # | ∇ | ∇ | † | ‡ | ‡ | ‡ | ⊕ |

8 POINT NO 150 PER LB. \$1 60

| | | | | | | | | | |
|-----|-----|-----|-----|-----|-----|-----|-----|-----|-----|
| 873 | 874 | 875 | 876 | 877 | 878 | 879 | 880 | 881 | 882 |
| ' | ° | # | ∇ | ∇ | † | † | ‡ | ‡ | ⊕ |

7 POINT NO 150 PER LB. \$1 80

| | | | | | | | |
|-----|-----|-----|-----|-----|-----|-----|-----|
| 865 | 866 | 867 | 868 | 869 | 870 | 871 | 872 |
| ' | ° | ∇ | † | † | ‡ | ‡ | " |

6 POINT NO 150 PER LB. \$2 00

| | | | | | | | |
|-----|-----|-----|-----|-----|-----|-----|-----|
| 857 | 858 | 859 | 860 | 861 | 862 | 863 | 864 |
| M | ' | ° | ∇ | † | † | ‡ | ⊕ |

5 1/2 POINT NO 150 PER LB \$2 40

| | | |
|-----|-----|-----|
| 854 | 855 | 856 |
| M | ° | ' |

12 POINT NO 120 PER LB. \$1 16

| | | | | | | | | | |
|-----|-----|-----|-----|-----|-----|-----|-----|-----|-----|
| 839 | 840 | 841 | 842 | 843 | 844 | 845 | 846 | 922 | 923 |
| + | × | % | % | 3 | 3 | 3 | ° | # | ‰ |

10 POINT NO 120 PER LB. \$1 30

| | | | | | | | | | | | |
|-----|-----|-----|-----|-----|-----|---------|-----|-----|-----|-----|-----|
| 739 | 740 | 741 | 742 | 743 | 744 | 745 | 746 | 747 | 748 | 749 | |
| — | = | + | × | ÷ | ÷ | ± | □ | □ | △ | > | |
| 750 | 751 | 752 | 753 | 754 | 755 | 756 | 757 | 758 | 759 | 760 | |
| < | ~ | √ | | ≅ | ∠ | L | □ | □ | ∞ | :: | |
| 761 | 762 | 763 | 764 | 765 | 766 | 766 1/2 | 767 | 768 | 769 | 770 | 771 |
| ∴ | : | ○ | □ | ° | ' | " | % | ‰ | ¢ | @ | |
| 772 | 773 | 774 | 775 | 776 | 777 | 778 | 779 | 780 | 781 | 782 | |
| ℙ | ℔ | ℞ | 5 | 3 | 3 | 3 | ℔ | ℔ | ‡ | ∞ | |
| 783 | 784 | 785 | 786 | 787 | 788 | 789 | 790 | 791 | 792 | | |
| ♁ | ♂ | ♃ | ♄ | ♅ | ♆ | ♇ | ♈ | ♉ | ♊ | | |
| 793 | 794 | 795 | 796 | 797 | 798 | 799 | 800 | 801 | 802 | 803 | |
| / | ∞ | ≈ | ♀ | ♂ | ♃ | ♄ | ♅ | ♆ | ♇ | ♈ | |
| 804 | 805 | 806 | 807 | 808 | 809 | 810 | 811 | 812 | 813 | 814 | |
| ♁ | ♂ | ♃ | ♄ | ♅ | ♆ | ♇ | ♈ | ♉ | ♊ | ♋ | |
| 815 | 816 | 817 | 818 | 819 | 820 | 821 | 822 | 823 | 824 | 825 | 826 |
| ♀ | ♂ | ♃ | ♄ | ♅ | ♆ | ♇ | ♈ | ♉ | ♊ | ♋ | ♌ |
| 827 | 828 | 829 | 830 | 831 | 832 | 833 | 834 | 835 | 836 | 837 | 838 |
| △ | □ | ♂ | ♃ | ♄ | ♅ | ♆ | ♇ | ♈ | ♉ | ♊ | ♋ |

8 POINT NO 120 PER LB. \$1 60

Table of 8 point no 120 characters including mathematical symbols like +, x, ÷, ±, □, △, <, >, and various decorative flourishes.

6 POINT NO 120 PER LB. \$2 00

Table of 6 point no 120 characters including mathematical symbols like +, x, ÷, ±, □, △, <, >, and various decorative flourishes.

924. 25 cts.



925. 25 cts.



847. 10 cts.



926. 20 cts.



848. 10 cts.



927. 20 cts.

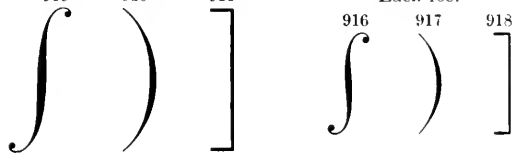

Table of decorative figures including integral sign (∫), summation sign (Σ), and Roman numeral (II).

Nos. 849 to 853, 15 cents each

Miscellaneous Signs are cast to order only

42 POINT NO 150 Each 15c. 30 POINT NO 150 Each 10c.



CANCELLED FIGURES

11 POINT NO 40 PER LB. 70 CTS

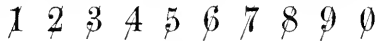

10 POINT NO 40 PER LB. 74 CTS

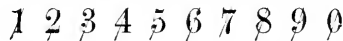

9 POINT NO 40 PER LB. 80 CTS

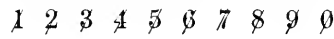

8 POINT NO 40 PER LB. 90 CTS

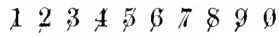

SPECIAL FIGURES

8 POINT TWO-THIRD FIGURES PER LB \$0 90

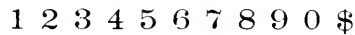

7 POINT FIVE-EIGHTH FIGURES PER LB. \$1 00

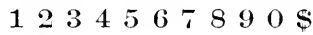

6 POINT THREE-QUARTER FIGURES PER LB. \$1 16

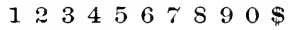

6 POINT FIVE-SEVENTH FIGURES PER LB. \$1 16

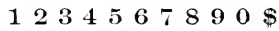

5 1/2 POINT FIVE-SEVENTH FIGURES PER LB. \$1 44

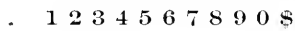

5 POINT TWO-THIRD FIGURES PER LB. \$1 80

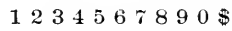

SPECIAL LOGOTYPES

See Time-Table Logotypes on page 696. Special Logotypes will be engraved and cast to order.

8 POINT

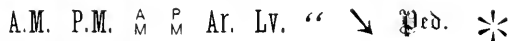

6 POINT

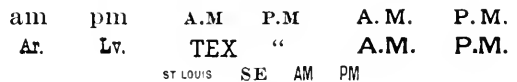

5 1/2 POINT



SUPERIOR AND INFERIOR LETTERS AND FIGURES

c-f

Prices quoted are per pound of either

12 POINT NO 150 PER LB. \$1 16
 abcdefghijklmnopqrst
 1234567890
 abcdefghijklmnopqrst
 1234567890

11 POINT NO 150 PER LB. \$1 22
 abcdefghijklmnopqrst
 1234567890
 abcdefghijklmnopqrst
 1234567890

10 POINT NO 150 PER LB. \$1 30
 abcdefghijklmnopqrstuv
 1234567890
 abcdefghijklmnopqrstuv
 1234567890

9 POINT NO 150 PER LB. \$1 44
 abcdefghijklmnopqrstuv
 1234567890
 abcdefghijklmnopqrstuv
 1234567890

8 POINT NO 150 PER LB. \$1 60
 abcdefghijklmnopqrstuvw
 1234567890
 abcdefghijklmnopqrstuvw
 1234567890

7 POINT NO 150 PER LB. \$1 80
 abcdefghijklmnopqrstuvw
 1234567890
 abcdefghijklmnopqrstuvw
 1234567890

6 POINT NO 150 PER LB. \$2 00
 abcdefghijklmnopqrstuvw
 1234567890
 abcdefghijklmnopqrstuvw
 1234567890

5½ POINT NO 40 PER LB \$2 40
 abcdefghijklmnopqrstvwxyz
 1234567890
 abcdefghijklmnopqrstvwxyz
 1234567890

DIAGONAL FRACTION MARKS

o

PRICE PER FONT, CONTAINING THREE SIZES \$0 75

12 POINT 9 POINT 6 POINT
 // // // // // // // // // // // // //

EXAMPLES

8²/₅ 5³/₈ 2⁷/₈ 24/100

3⁴/₅ 2³/₈ 1½ 3¼ 15/100

5½ 8⁷/₈ 4²/₃ 5¾ 6¾ 150/1000

PIECE FRACTIONS

c-e

12 POINT NO 120 PER LB. \$2 00
 1 2 3 4 5 6 7 8 9 0
 1 2 3 4 5 6 7 8 9 0
 2/5 3/16 5/36 13/68 9/100 33/100

11 POINT NO 120 PER LB. \$2 40
 1 2 3 4 5 6 7 8 9 0
 1 2 3 4 5 6 7 8 9 0
 2/3 3/7 5/9 4/25 35/86 7/234 68/275

10 POINT NO 120 PER LB. \$2 80
 1 2 3 4 5 6 7 8 9 0
 1 2 3 4 5 6 7 8 9 0
 2/5 3/20 4/68 7/90 9/10 24/160 45/200

9 POINT NO 120 PER LB. \$3 20
 1 2 3 4 5 6 7 8 9 0 1 2 3 4 5 6 7 8 9 0
 2/5 4/27 5/36 13/68 12/160 17/380 33/1000

8 POINT NO 120 PER LB. \$3 60
 1 2 3 4 5 6 7 8 9 0 1 2 3 4 5 6 7 8 9 0
 1/4 2/5 3/17 6/45 23/88 8/150 31/497 97/1500

7 POINT NO 40 PER FONT \$5 00
 1 2 3 4 5 6 7 8 9 0 1 2 3 4 5 6 7 8 9 0
 1/2 2/5 3/7 4/28 4/45 6/82 23/78 23/135 24/287 33/4785

6 POINT NO 120 PER LB. \$5 00
 1 2 3 4 5 6 7 8 9 0 1 2 3 4 5 6 7 8 9 0
 1/2 3/7 7/9 27/47 5/38 8/45 23/74 100/100 24/150 63/230 133/1000

SPECIAL FRACTIONS

c-f

8 POINT NO 1528 1 LB. FONT \$0 90
 1/4 1/2 3/4 1/3 2/3 1/8 3/8 5/8 7/8

7 POINT NO 1528 1 LB. FONT \$1 00
 1/4 1/2 3/4 1/3 2/3 1/8 3/8 5/8 7/8

6 POINT NO 1528 1 LB. FONT \$1 16
 1/4 1/2 3/4 1/3 2/3 1/8 3/8 5/8 7/8

5½ POINT NO 1528 1 LB. FONT \$1 44
 1/4 1/2 3/4 1/3 2/3 1/8 3/8 5/8 7/8

6 POINT NO 154 1 LB. FONT \$1 16
 1/4 1/2 3/4 1/3 2/3 1/8 3/8 5/8 7/8

5½ POINT NO 154 1 LB. FONT \$1 44
 1/4 1/2 3/4 1/3 2/3 1/8 3/8 5/8 7/8

5½ POINT NO 40 1 LB. FONT \$1 44
 ONE-AND-A-HALF EM FRACTIONS
 1/16 3/16 5/16 7/16 9/16 11/16 13/16 15/16

DE VINNE FRACTIONS

Each font has same assortment as shown in 10 Point specimen

24 POINT PER FONT 50 CTS

1/4 1/2 3/4 1/3 2/3

14 POINT PER FONT 50 CTS

1/4 1/2 3/4 1/3 2/3 1/8 3/8

10 POINT PER FONT 50 CTS

1/4 1/2 3/4 1/3 2/3 1/8 3/8 5/8 7/8 ¢ %

7 POINT PER FONT 50 CTS

1/4 1/2 3/4 1/3 2/3 1/8 3/8 5/8 7/8 ¢ %

18 POINT PER FONT 50 CTS

1/4 1/8 3/8 5/8 7/8

12 POINT PER FONT 50 CTS

1/3 2/3 1/8 3/8 5/8 7/8 ¢ %

8 POINT PER FONT 50 CTS

1/4 1/2 3/4 1/3 2/3 1/8 3/8 5/8 7/8 ¢ %

6 POINT PER FONT 50 CTS

1/4 1/2 3/4 1/3 2/3 1/8 3/8 5/8 7/8 ¢ %

DE VINNE CONDENSED FRACTIONS

36 POINT PER FONT 75 CTS

1/4 1/2 3/4 1/3 2/3

30 POINT PER FONT 75 CTS

1/4 1/2 3/4 1/3 2/3 1/8 3/8 5/8 7/8

24 POINT PER FONT 50 CTS

1/4 1/2 3/4 1/3 2/3 1/8 3/8 5/8 7/8

18 POINT PER FONT 50 CTS

1/4 1/2 3/4 1/3 2/3 1/8 3/8 5/8 7/8

14 POINT PER FONT 50 CTS

1/4 1/2 3/4 1/3 2/3 1/8 3/8 5/8 7/8

12 POINT PER FONT 50 CTS

1/4 1/2 3/4 1/3 2/3 1/8 3/8 5/8 7/8

10 POINT PER FONT 50 CTS

1/4 1/2 3/4 1/3 2/3 1/8 3/8 5/8 7/8

8 POINT PER FONT 50 CTS

1/4 1/2 3/4 1/3 2/3 1/8 3/8 5/8 7/8

6 POINT PER FONT 50 CTS

1/4 1/2 3/4 1/3 2/3 1/8 3/8 5/8 7/8

QUENTELL FRACTIONS

36 POINT PER FONT 75 CTS

1/4 1/2 3/4 1/3 2/3

30 POINT PER FONT 75 CTS

2/3 1/8 3/8 5/8 7/8

24 POINT PER FONT 50 CTS

1/4 1/2 3/4 1/3 2/3 1/8 3/8

18 POINT PER FONT 50 CTS

1/4 1/2 3/4 1/3 2/3 1/8 3/8 5/8 7/8

14 POINT PER FONT 50 CTS

1/4 1/2 3/4 1/3 2/3 1/8 3/8 5/8 7/8

12 POINT PER FONT 50 CTS

1/4 1/2 3/4 1/3 2/3 1/8 3/8 5/8 7/8

10 POINT PER FONT 50 CTS

1/4 1/2 3/4 1/3 2/3 1/8 3/8 5/8 7/8

8 POINT PER FONT 50 CTS

1/4 1/2 3/4 1/3 2/3 1/8 3/8 5/8 7/8

6 POINT PER FONT 50 CTS

1/4 1/2 3/4 1/3 2/3 1/8 3/8 5/8 7/8

CUSHING FRACTIONS^A

12 POINT FONT \$1 00

1/6 1/3 2/3 1/2 1/4 3/8 5/8 7/8

8 PT FONT \$1 00

1/6 1/3 2/3 1/2 1/4 3/8 5/8 7/8

6 PT FONT \$1 00

1/6 1/3 2/3 1/2 1/4 3/8 5/8 7/8

10 PT FONT \$1 00

1/6 1/3 2/3 1/2 1/4 3/8 5/8 7/8

For Body Type Fractions, see pages 702 and 703

DORIC FRACTIONS

42 POINT 1 LB FONT 54 CTS

$\frac{1}{4}$ $\frac{1}{2}$ $\frac{3}{4}$

36 POINT 1 LB FONT 56 CTS

$\frac{1}{4}$ $\frac{1}{2}$ $\frac{3}{4}$

30 POINT 1 LB FONT 56 CTS

$\frac{1}{4}$ $\frac{1}{2}$ $\frac{3}{4}$

24 POINT 1 LB FONT 56 CTS

$\frac{1}{4}$ $\frac{1}{2}$ $\frac{3}{4}$

GOTHIC FRACTIONS

Each font has same assortment as shown in 6 Point specimen

18 POINT 1 LB FONT 60 CTS

$\frac{1}{4}$ $\frac{1}{2}$ $\frac{3}{4}$ $\frac{1}{3}$ $\frac{2}{3}$

12 POINT 1 LB FONT 66 CTS

$\frac{3}{4}$ $\frac{1}{3}$ $\frac{2}{3}$ $\frac{1}{8}$ $\frac{3}{8}$ $\frac{5}{8}$

6 POINT 1 LB FONT \$1 16

$\frac{1}{4}$ $\frac{1}{2}$ $\frac{3}{4}$ $\frac{1}{3}$ $\frac{2}{3}$ $\frac{1}{8}$ $\frac{3}{8}$ $\frac{5}{8}$ $\frac{7}{8}$

ROMAN FRACTIONS

48 POINT 1 LB FONT 54 CTS

$\frac{1}{4}$ $\frac{1}{2}$ $\frac{3}{4}$

30 POINT 1 LB FONT 56 CTS

$\frac{1}{4}$ $\frac{1}{2}$ $\frac{3}{4}$

24 POINT 1 LB FONT 56 CTS

$\frac{1}{4}$ $\frac{1}{2}$ $\frac{3}{4}$ $\frac{1}{3}$ $\frac{2}{3}$

**BOLDFACE
No 120 FRACTIONS**

30 POINT 1 LB FONT 56 CTS

$\frac{1}{2}$ $\frac{3}{4}$ $\frac{1}{3}$ $\frac{2}{3}$

24 POINT 1 LB FONT 60 CTS

$\frac{1}{4}$ $\frac{1}{2}$ $\frac{3}{4}$ $\frac{1}{3}$ $\frac{2}{3}$

18 POINT 1 LB FONT 60 CTS

$\frac{1}{4}$ $\frac{1}{2}$ $\frac{3}{4}$ $\frac{1}{3}$ $\frac{2}{3}$

12 POINT 1 LB FONT 66 CTS

$\frac{1}{4}$ $\frac{1}{2}$ $\frac{3}{4}$

GOTHIC COND. FRACTIONS

36 POINT 1 LB FONT 56 CTS

$\frac{1}{4}$ $\frac{1}{2}$ $\frac{3}{4}$ $\frac{1}{3}$ $\frac{2}{3}$

$\frac{1}{8}$ $\frac{3}{8}$ $\frac{5}{8}$ $\frac{7}{8}$

24 POINT 1 LB FONT 56 CTS

$\frac{1}{4}$ $\frac{1}{2}$ $\frac{3}{4}$ $\frac{1}{3}$ $\frac{2}{3}$ $\frac{1}{8}$

$\frac{3}{8}$ $\frac{5}{8}$ $\frac{7}{8}$

18 POINT 1 LB FONT 60 CTS

$\frac{1}{4}$ $\frac{1}{2}$ $\frac{3}{4}$ $\frac{1}{3}$ $\frac{2}{3}$ $\frac{1}{8}$ $\frac{3}{8}$ $\frac{5}{8}$ $\frac{7}{8}$

12 POINT 1 LB FONT 66 CTS

$\frac{1}{4}$ $\frac{1}{2}$ $\frac{3}{4}$ $\frac{1}{3}$ $\frac{2}{3}$ $\frac{1}{8}$ $\frac{3}{8}$ $\frac{5}{8}$ $\frac{7}{8}$

CALEDONIAN FRACTIONS

18 POINT 1 LB FONT 60 CTS

$\frac{1}{4}$ $\frac{1}{2}$ $\frac{3}{4}$ $\frac{2}{3}$

FULL FACE FRACTIONS

8 POINT No 7 1 LB FONT 90 CTS

$\frac{1}{4}$ $\frac{1}{2}$ $\frac{3}{4}$ $\frac{1}{3}$ $\frac{2}{3}$ $\frac{1}{8}$ $\frac{3}{8}$ $\frac{5}{8}$ $\frac{7}{8}$

6 POINT No 7 1 LB FONT \$1 16

$\frac{1}{4}$ $\frac{1}{2}$ $\frac{3}{4}$ $\frac{1}{3}$ $\frac{2}{3}$ $\frac{1}{8}$ $\frac{3}{8}$ $\frac{5}{8}$ $\frac{7}{8}$

JOB COMMERCIAL SIGNS

Each size is complete as here shown

36 POINT PER FONT 50 CTS

@ % lb

30 POINT PER FONT 50 CTS

@ % lb

18 POINT PER FONT 50 CTS

@ % lb c

12 POINT PER FONT 50 CTS

@ % lb c

ANTIQUE FRACTIONS

All sizes are complete as here shown

36 POINT No 20 PER FONT \$1 00 30 POINT No 20 PER FONT \$1 00

$\frac{1}{4}$ $\frac{1}{2}$ $\frac{3}{4}$ $\frac{1}{4}$ $\frac{1}{2}$ $\frac{3}{4}$

18 POINT No 20 PER FONT \$1 00

$\frac{1}{4}$ $\frac{1}{2}$ $\frac{3}{4}$ $\frac{1}{8}$ $\frac{3}{8}$ $\frac{5}{8}$ $\frac{7}{8}$

12 POINT No 22 PER FONT \$1 00

$\frac{1}{4}$ $\frac{1}{2}$ $\frac{3}{4}$ $\frac{1}{8}$ $\frac{3}{8}$ $\frac{5}{8}$ $\frac{7}{8}$

18 POINT No 22 PER FONT \$1 00 14 POINT No 22 PER FONT \$1 00

$\frac{1}{4}$ $\frac{1}{2}$ $\frac{3}{4}$ $\frac{1}{4}$ $\frac{1}{2}$ $\frac{3}{4}$

CALENDAR FIGURES

Put up in fonts sufficient to set one month, with enough extra figures and sorts to complete each of the twelve months. Order by name and No.

No 1807 \$0 75

239

No 6008

\$5 25

45

No 6011

\$5 75

73

No 1810 \$1 00

168

No 2407 \$1 00

239

No 2410 \$1 25

168

No 5408

\$4 65

45

No 5411

\$4 80

73

No 3010 \$1 75

168

No 3007 \$1 45

239

No 3610 \$2 20

168

No 3607 \$1 90

239

No 4208 \$3 10

45

No 3611 \$2 80

73

No 4210 \$3 00

168

No 4207 \$2 25

239

No 3608 \$2 15

45

No 3011 \$2 15

73

No 4810 \$3 75

168

No 5407 \$3 60

239

No 3008 \$1 65

45

No 2411 \$1 35

73

No 5410 \$4 65

168

No 2408 \$1 40

45

No 1811 \$1 00

73

No 6010 \$5 25

168

No 6007 \$4 00

239

No 2008 \$1 25

45

No 1812 \$1 00

34

CALENDAR FIGURES

Put up in fonts sufficient to set one month, with enough extra figures and sorts to complete each of the twelve months. Order by name and No.

No 1808 \$1 00

45

No 6001

78

\$5 50

No 6005

26

\$4 50

No 1802 \$0 75

937

No 2406 \$1 30

45

No 2402 \$1 00

937

No 5401

78

\$4 70

No 5405

26

\$5 00

No 3002 \$1 35

937

No 3006 \$1 95

45

No 3606 \$2 60

45

No 4801

78

\$3 65

No 4805

26

\$3 90

No 3602 \$1 90

937

No 4206 \$3 50

45

No 4201

78

\$3 15

No 4205

26

\$3 30

No 4202 \$2 40

937

No 4806 \$4 00

45

No 3601

78

\$2 30

No 3605

26

\$2 50

No 4802 \$3 00

937

No 5406 \$5 20

45

No 3001

78

\$1 90

No 3005

26

\$1 95

No 5402 \$3 80

937

No 6006 \$5 90

45

No 2401

78

\$1 25

No 2405

26

\$1 30

No 6002

937

\$4 45

No 1801

78

\$1 00

No 1805

26

\$1 00

ADVERTISING FIGURES

*Each font contains five each figures 2, 3, 4, 6, 7, 8, 9, dollar mark, period and lower case "c;"
nine each figures 1, 5 and 0—seventy-seven characters in all.*

No 6022 \$4 45

2 3 4 5

No 6021 \$5 50

2 3 4

No 5422 \$3 80

1 2 3 4 5

No 5421 \$4 70

1 2 3 4

No 4822 \$3 00

6 7 8 9 0

No 4821 \$3 65

5 6 7 8

No 4222 \$2 40

1 2 3 4 5 6

No 4221 \$3 15

1 2 3 4 5

No 3622 \$1 90

1 2 3 4 5 6 7

No 3621 \$2 30

5 6 7 8 9 0

No 3022 \$1 35

1 2 3 4 5 6 7 8 9

No 3021 \$1 90

1 2 3 4 5 6

No 2422 \$1 00

1 3 2 4 5 6 7 8 9 0

No 2421 \$1 25

1 2 3 4 5 6 7 8 9

No 1822 \$0 75

1 2 3 4 5 6 7 8 9 0

No 1821 \$1 00

1 2 3 4 5 6 7 8 9 0

ADVERTISING FIGURES

*Each font contains five each figures 2, 3, 4, 6, 7, 8, 9, dollar mark, period and lower case "c;"
 nine each figures 1, 5 and 0—seventy-seven characters in all.*

No 6023 \$3 25

1 2 3 4 5 6

No 6026 \$5 90

1 2 3

No 5423 \$2 80

1 2 3 4 5 6 7

No 5426 \$5 20

4 5 6

No 4823 \$2 15

1 2 3 4 5 6 7 8

No 4826 \$4 00

7 8 9 0

No 4223 \$1 80

1 2 3 4 5 6 7 8 9

No 4226 \$3 50

1 2 3 4

No 3623 \$1 40

1 2 3 4 5 6 7 8 9 0

No 3626 \$2 60

1 2 3 4 5

No 3023 \$1 00

1 2 3 4 5 6 7 8 9 0

No 3026 \$1 95

1 2 3 4 5 6

No 2423 \$0 75

1 2 3 4 5 6 7 8 9 0

No 2426 \$1 30

1 2 3 4 5 6 7 8

No 1823 \$0 50

1 2 3 4 5 6 7 8 9 0

No 1826 \$1 00

1 2 3 4 5 6 7 8 9 0

ADVERTISING FIGURES

*Each font contains five each figures 2, 3, 4, 6, 7, 8, 9, dollar mark, period and lower case "c;"
nine each figures 1, 5 and 0—seventy-seven characters in all.*

No 6030

\$5 25

2 3 4

No 6025

\$5 00

2 3 4

No 5430

\$4 65

5 6 7 8

No 5425

\$5 00

5 6 7 8

No 4830

\$3 75

1 2 3 4

No 4825

\$3 90

1 2 3 4

No 4230

\$3 00

5 6 7 8 9

No 4225

\$3 30

5 6 7 8 9

No 3630

\$2 20

5 6 7 8 9 0

No 3625

\$2 50

5 6 7 8 9

No 3030

\$1 75

1 2 3 4 5 6 7 8

No 3025

\$1 95

1 2 3 4 5 6

No 2430

\$1 25

1 2 3 4 5 6 7 8 9

No 2425

\$1 30

1 2 3 4 5 6 7 8

No 1830

\$1 00

1 2 3 4 5 6 7 8 9 0

No 1825

\$1 00

1 2 3 4 5 6 7 8 9 0

SECTIONAL CALENDARS

| | | | | | | | | |
|---|------|-----|------|-----|-----|-----|------|--|
| 190 Sun 1 8 15 22 | 1900 | | JULY | | | | 1900 | |
| | Sun | Mon | Tue | Wed | Thu | Fri | Sat | |
| | -- | -- | -- | -- | -- | 1 | 2 | |
| | 3 | 4 | 5 | 6 | 7 | 8 | 9 | |
| | 10 | 11 | 12 | 13 | 14 | 15 | 16 | |
| | 17 | 18 | 19 | 20 | 21 | 22 | 23 | |
| | 24 | 25 | 26 | 27 | 28 | 29 | 30 | |
| | 31 | -- | -- | -- | | | | |

Sectional Calendar No. 6. — \$3.00

| | | | | | | | |
|------|-----|------|-----|-----|-----|------|--|
| 1901 | | JUNE | | | | 1901 | |
| Sun | Mon | Tue | Wed | Thu | Fri | Sat | |
| | | | 1 | 2 | 3 | 4 | |
| 5 | 6 | 7 | 8 | 9 | 10 | 11 | |
| 12 | 13 | 14 | 15 | 16 | 17 | 18 | |
| 19 | 20 | 21 | 22 | 23 | 24 | 25 | |
| 26 | 27 | 28 | 29 | 30 | | | |

Sectional Calendar, No. 5. — \$2.50

| | | |
|--|--|--|
| | | |
|--|--|--|

Sectional Calendar No. 8. — \$4.00

| | | |
|-----|----|-------|
| | 19 | 16 |
| Wed | | MARCH |

Rules and Figures for One Month, with Changes for Ten Years

**PERPETUAL
CALENDAR
LOGOTYPES**

No. 3.—\$3.00 per set, including fifty-two logotypes, rules and fonts for month and year; can be used for any month in any year; can be changed in three minutes.

No. 2.—\$3.50 per set, including fifty-two logotypes, rules and fonts for month and year; can be used for any month in any year; can be changed in three minutes.

| | | | | | | | | |
|------|----------------------------------|--------------|-----|-----|-----|-----|------|--|
| 1901 | | MARCH | | | | | 1901 | |
| SUN | MON | TUE | WED | THU | FRI | SAT | | |
| | | | | | 1 | 2 | | |
| 3 | 4 | 5 | 6 | 7 | 8 | 9 | | |
| 10 | 11 | 12 | 13 | 14 | 15 | 16 | | |
| 17 | 18 | 19 | 20 | 21 | 22 | 23 | | |
| 24 | 25 | 26 | 27 | 28 | 29 | 30 | | |
| 31 | <i>Perpetual Calendar, No. 3</i> | | | | | | | |

| | | | | | | | | |
|------|----------------------------------|---------------|----|----|----|----|------|--|
| 1902 | | AUGUST | | | | | 1902 | |
| Su | Mo | Tu | We | Th | Fr | Sa | | |
| | | | | | 1 | 2 | | |
| 3 | 4 | 5 | 6 | 7 | 8 | 9 | | |
| 10 | 11 | 12 | 13 | 14 | 15 | 16 | | |
| 17 | 18 | 19 | 20 | 21 | 22 | 23 | | |
| 24 | 25 | 26 | 27 | 28 | 29 | 30 | | |
| 31 | <i>Perpetual Calendar, No. 2</i> | | | | | | | |

14

1900

SAT

U S

26

**PERPETUAL
CALENDAR
LOGOTYPES**

No. 4.—\$2.50 per set, including fifty-two logotypes, rules and fonts for month and year; can be used for any month in any year; change made in three minutes.

No. 1.—\$1.00 per set, including fifty-two logotypes, rules and fonts for month and year; can be used for any month in any year; change made in three minutes.

Th APRIL 31
19 20 F

| | | | | | | |
|---------------------|----------------------------------|----|----|----|----|----|
| 1901 SEPTEMBER 1901 | | | | | | |
| Su | Mo | Tu | We | Th | Fr | Sa |
| 1 | 2 | 3 | 4 | 5 | 6 | 7 |
| 8 | 9 | 10 | 11 | 12 | 13 | 14 |
| 15 | 16 | 17 | 18 | 19 | 20 | 21 |
| 22 | 23 | 24 | 25 | 26 | 27 | 28 |
| 29 | 30 | | | | | |
| | <i>Perpetual Calendar, No. 4</i> | | | | | |

| | | | | | | | | |
|------|-----|----------------------------------|-----|-----|-----|-----|------|--|
| 1900 | | JUNE | | | | | 1900 | |
| SUN | MON | TUE | WED | THU | FRI | SAT | | |
| | | | | | 1 | 2 | | |
| 3 | 4 | 5 | 6 | 7 | 8 | 9 | | |
| 10 | 11 | 12 | 13 | 14 | 15 | 16 | | |
| 17 | 18 | 19 | 20 | 21 | 22 | 23 | | |
| 24 | 25 | 26 | 27 | 28 | 29 | 30 | | |
| | | <i>Perpetual Calendar, No. 1</i> | | | | | | |

UNITED STATES SIGNAL FLAGS

36 POINT

PER SET \$1 25

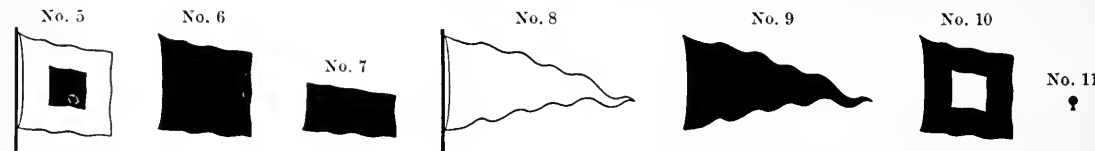
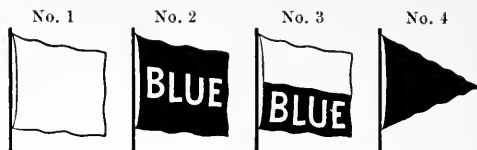

24 POINT

PER SET \$1 00

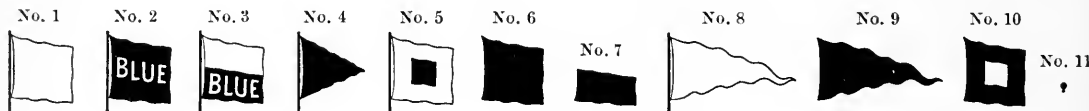

EXPLANATION OF WEATHER SIGNALS

Clear or Fair Weather.—WHITE, SQUARE FLAG. Print No. 1 in black. Displayed alone, indicates fair weather, stationary temperature; displayed with No. 4 above it, indicates fair weather, warmer; displayed with No. 4 below it, indicates fair weather, colder.

Rain or Snow.—BLUE, SQUARE FLAG. Use No. 2, or print No. 6 in blue over No. 1 in black. Displayed alone indicates rain or snow, stationary temperature; displayed with No. 4 above it, indicates rain or snow, warmer; displayed with No. 4 below it, indicates rain or snow, colder.

Local Rain.—WHITE AND BLUE, SQUARE FLAG. Use No. 3, or print No. 7 in blue over lower half of No. 1 in black. Displayed alone, indicates local rain, stationary temperature; displayed with No. 4 above it, indicates local rain, warmer; displayed with No. 4 below it, indicates local rain, colder.

Temperature Signal.—BLACK, TRIANGULAR FLAG. Print No. 4 in black. Displayed in conjunction with other signals, as above described.

Cold Wave.—WHITE, SQUARE FLAG, BLACK CENTER. Print No. 5 in black. Displayed alone indicates temperature will fall 20° or more, to a minimum of 32° or less. When displayed with No. 1, indicates fair weather, cold wave.

EXPLANATION OF WIND SIGNALS

Storm.—RED, SQUARE FLAG, BLACK CENTER. Print No. 10 in red over No. 5 in Black. When displayed, indicates that storm of marked violence is expected. **Hurricane.**—Indicated by two Storm Flags displayed one above the other.

Cautionary.—RED, SQUARE FLAG, WHITE CENTER. Print No. 10 in red over No. 1 in black. When displayed, indicates that the winds expected will not be so severe. Well-found, seaworthy vessels can meet them without danger.

Easterly Winds.—RED PENNANT. Print No. 9 in red over No. 8 in black. When displayed above either Cautionary or Storm Flags, indicates northeasterly winds; when below, southeasterly; when alone, that special information of storms is to be obtained by calling on Signal Officer in charge.

Westerly Winds.—WHITE PENNANT. Print No. 8 in black. Displayed above either Cautionary or Storm Flags, indicates northwesterly winds; below, southwesterly.

WEATHER INDICATORS

36 POINT

EACH 15 CENTS

PER FONT \$1 75

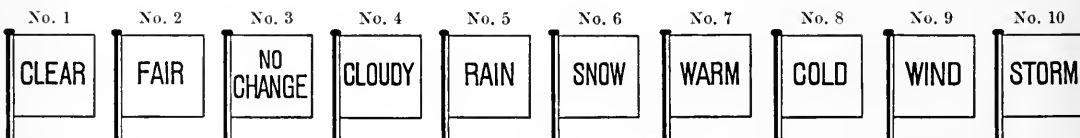

ENGRAVING BLANKS

| | | 50 OR 100 OR | |
|-----------|------|--------------|------|
| No. | EACH | MORE | MORE |
| No. 1E | 25 | 16 | 14 |
| No. 2E | 20 | 16 | 14 |
| No. 3E | 20 | 14 | 12 |
| No. 4E | 15 | 12 | 10 |
| No. 5E | 15 | 10 | 8 |
| No. 6E | 10 | 6 | 5 |
| No. 7E | 15 | 10 | 8 |
| No. 8E | 15 | 10 | 8 |
| No. 9E | 25 | 16 | 14 |
| No. 10E | 10 | 6 | 5 |
| No. 11E | 10 | 6 | 5 |
| No. 12E | 10 | 6 | 5 |
| No. 13E | 10 | 6 | 5 |
| No. 14E | 10 | 6 | 5 |
| No. 15E | 10 | 6 | 5 |
| No. 16E | 10 | 6 | 5 |
| No. 4148F | 15 | 12 | 10 |

FIVE-POINTED STARS

Nos. 201F to 215F put up in fonts containing four of each No., \$1.00



Nos. 201F to 210F, eight of any size, 25c.; Nos. 211F and 212F, eight of either size, 35c.; Nos. 213F to 215F, eight of any size, 50c.; Nos. 216F and 217F, 15c. each; Nos. 218F and 219F, 20c. each; No. 220F, 25c. each.

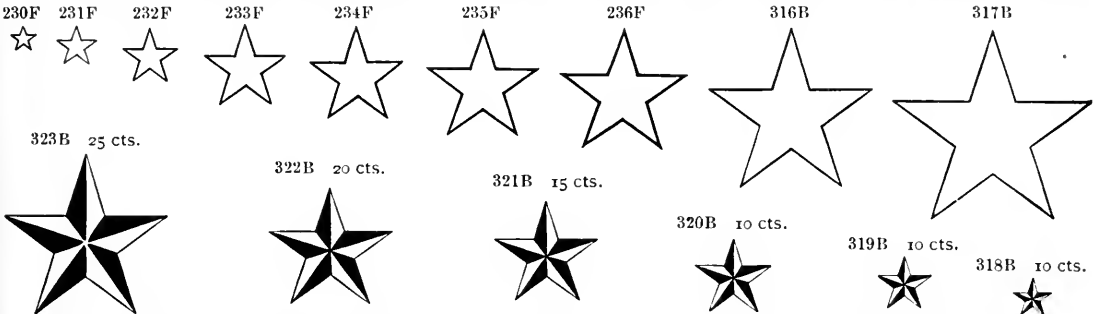

Nos. 230F to 232F, per set of eight of any size, 35c.; Nos. 233F to 235F, four of any size, 40c.; Nos. 236F and 316B, four of either size, 60c.; No. 317B, 20c.

MALTESE CROSSES

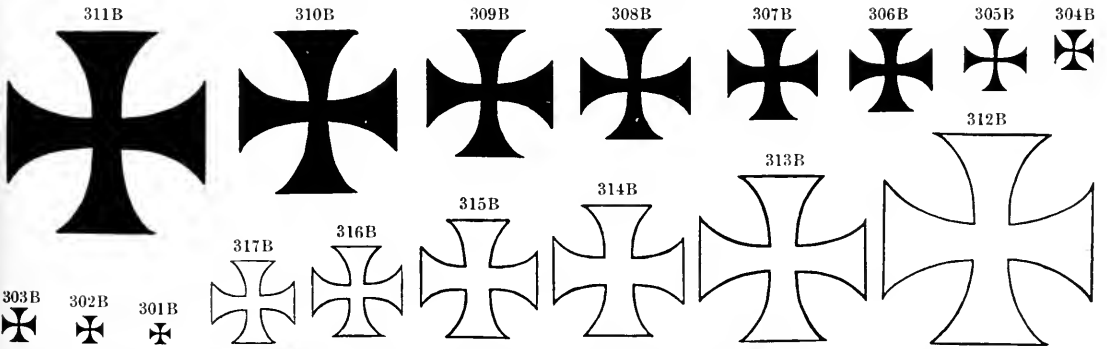

Nos. 301B to 304B, eight of any size, 25c.; No. 305B, per set of eight, 30c.; Nos. 306B, 307B, 316B, 317B, four of any size, 35c.; Nos. 308B, 309B, 314B, 315B, four of any size, 50c.; Nos. 310B, 313B, 20c. each; Nos. 311B, 312B, 25c. each.

SIX POINT STARS

3-pound fonts, containing both light and dark stars, with spaces and quads, \$3.25

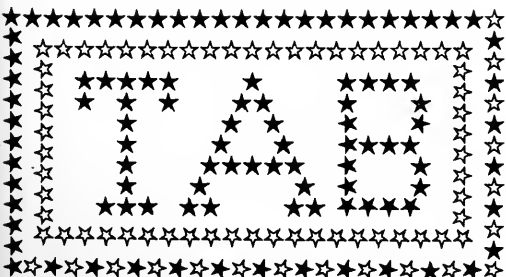

BEARERS

Cast to order in fonts of not less than 25 lbs. of one size at Roman prices

| | |
|------------------------|------------------------|
| 12 POINT | PER LB \$0 68 |
| ● ● ● ● ● ● | |
| 11 POINT PER LB \$0 70 | 10 POINT PER LB \$0 74 |
| ● ● ● ● ● ● | ● ● ● ● ● ● |
| 9 POINT PER LB \$0 80 | 8 POINT PER LB \$0 90 |
| ● ● ● ● ● ● | ● ● ● ● ● ● |
| 7 POINT PER LB \$1 00 | 6 POINT PER LB \$1 16 |
| ● ● ● ● ● ● | ● ● ● ● ● ● |

CHESSMEN AND CHECKERS

24 POINT CHESSMEN

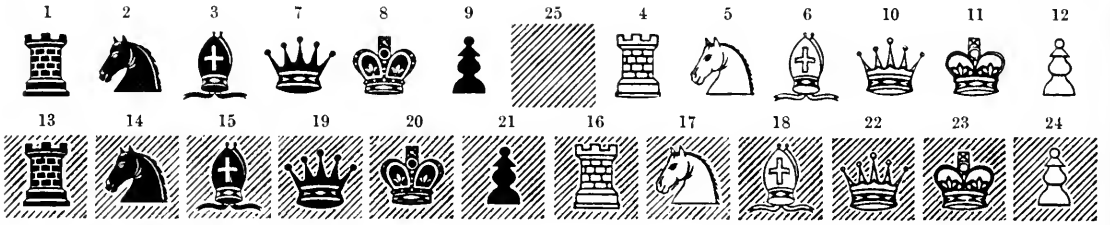

20 POINT CHESSMEN

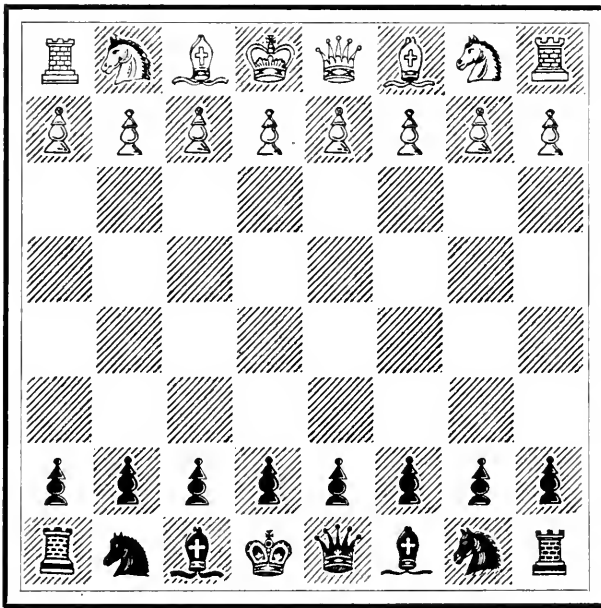

PER FONT WITH RULES \$4 80



20 PT CHECKERS

PER FONT WITH RULES \$3 40



24 PT CHECKERS

PER FONT WITH RULES \$3 40



16 PT CHESSMEN

PER FONT WITH RULES \$4 80

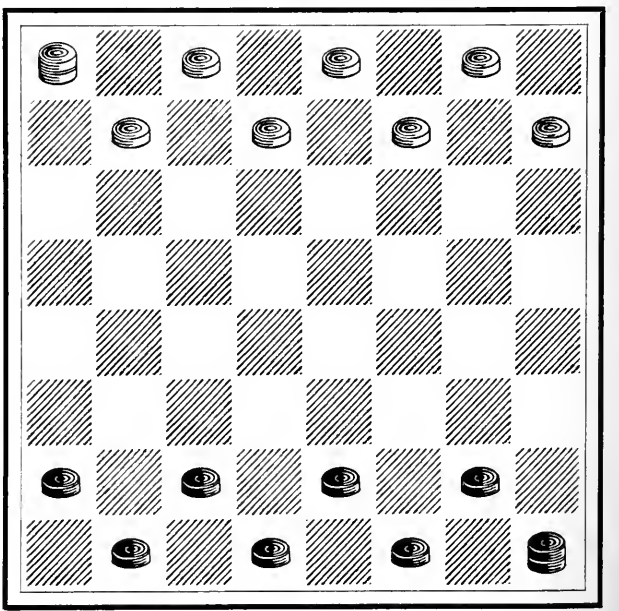
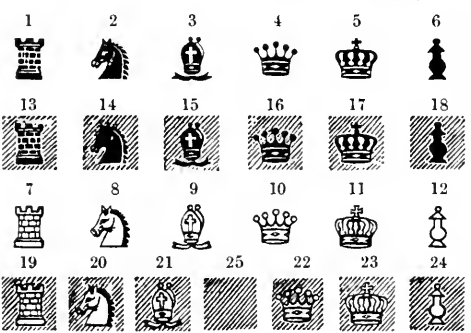

11 POINT CHECKERS

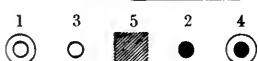

PER FONT WITH RULES \$2 00

CARD PIPS

32 POINT SERIES 1
PER FONT 52 PIECES \$5 00

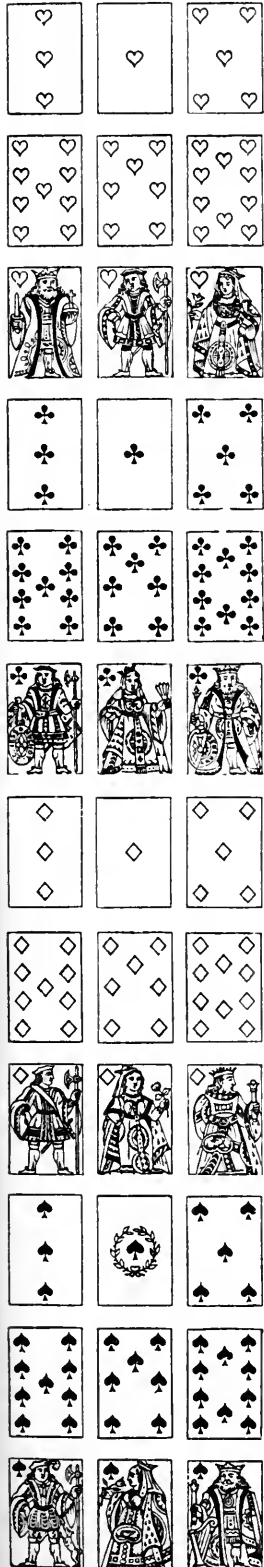

CARD INDICATORS

24 PT PER FONT \$1 75



10 PT PER LB \$1 30
12 PT PER LB \$1 16



Cast to order on 10 Point
or 12 Point body

6 POINT PER FONT \$5 50

Complete with Rules, Leads and Spaces

| | | | |
|-----|------|------|------|
| 3 ♠ | A ♠ | 4 ♠ | ♣ 4 |
| 6 ◇ | J ◇ | K ◇ | A ◇ |
| 7 ◇ | 9 ◇ | 2 ◇ | Q ◇ |
| ♥ 9 | ♥ 10 | 5 ◇ | 10 ◇ |
| ♣ 2 | ♣ A | ♣ 3 | ♣ 7 |
| ♥ 2 | ♣ J | ♣ Q | ♣ K |
| ♥ 3 | ♥ 6 | ♥ A | ♥ 4 |
| 2 ♠ | ♣ 5 | K ♠ | ♥ 5 |
| 5 ♠ | ♣ 6 | 7 ♠ | 8 ◇ |
| 6 ♠ | ♣ 9 | 8 ♠ | 4 ◇ |
| 9 ♠ | 10 ♣ | 10 ♠ | 3 ◇ |
| ♥ Q | ♥ K | J ♠ | ♣ 8 |
| ♥ 7 | ♥ 8 | Q ♠ | ♥ J |



No. 82½. 15 cts. No. 83½. 15 cts.

SET OF FOUR
40 CENTS



No. 84½. 15 cts. No. 85½. 15 cts.



No. 918E. 20 cts. No. 919E. 20 cts.

SET OF FOUR
50 CENTS

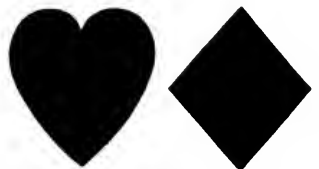

No. 920E. 20 cts. No. 921E. 20 cts.

ARROWS

6 POINT 15 CTS PER SET



WHIST MARKERS

18 POINT \$1 00 PER POUND



RECIPE MARKS



LOCUS SIGILLI

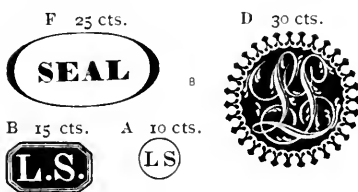

ELECTION SIGNS

For the various States using the Australian ballot. Additional signs will be made from time to time to conform with the changes in the election laws of the different States. If recent changes have been made in the election laws of your State, send for specimen sheet which will contain all new signs and emblems.

ILLINOIS AND IOWA

20 POINT ANTIQUE EX. COND. NO. 150 10 A \$2 00

12 POINT ROMAN NO. 64

INDEPENDENT TICKET.

JOHN J. BROWNING.

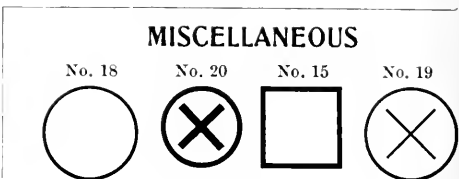
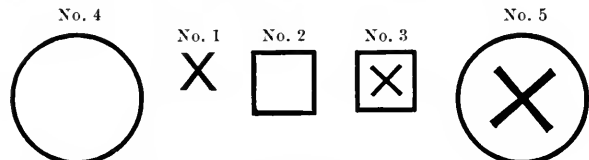

KENTUCKY AND MICHIGAN

OHIO

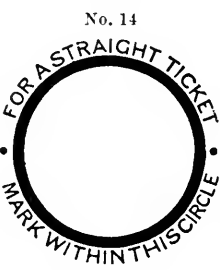
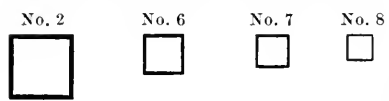

INDIANA

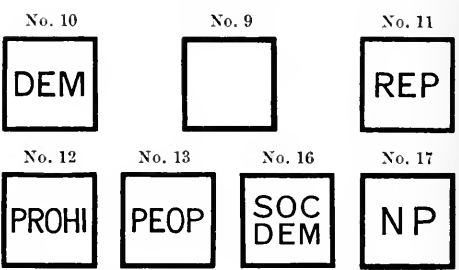

WISCONSIN

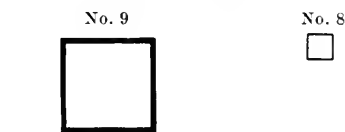

| No. | Body | Each | 50 or more Each | 100 or more Each | No. | Body | Each | 50 or more Each | 100 or more Each | No. | Body | Each | 50 or more Each | 100 or more Each |
|------|----------|-------|-----------------|------------------|-----|----------|-------|-----------------|------------------|-------|----------|-------|-----------------|------------------|
| 1-12 | Point | \$.05 | \$.04 | \$.03 | 8- | 8 Point | \$.06 | \$.04 | \$.03 | 15-24 | Point | \$.06 | \$.04 | \$.04 |
| 2- | 20 Point | .06 | .04 | .03 | 9- | 30 Point | .06 | .04 | .04 | 16- | 30 Point | .06 | .04 | .04 |
| 3- | 20 Point | .06 | .04 | .03 | 10- | 30 Point | .06 | .04 | .04 | 17- | 30 Point | .06 | .04 | .04 |
| 4- | 40 Point | .15 | .12 | .10 | 11- | 30 Point | .06 | .04 | .04 | 18- | 30 Point | .06 | .04 | .04 |
| 5- | 40 Point | .15 | .12 | .10 | 12- | 30 Point | .06 | .04 | .04 | 19- | 30 Point | .06 | .04 | .04 |
| 6- | 12 Point | .06 | .04 | .03 | 13- | 30 Point | .06 | .04 | .04 | 20- | 24 Point | .06 | .04 | .04 |
| 7- | 10 Point | .06 | .04 | .03 | 14- | 72 Point | .25 | — | — | | | | | |

RULES FOR WISCONSIN BALLOTS

| | Brass | End Wood | | Brass | End Wood |
|-----------------------------|--------|----------|------------------------------|--------|----------|
| 5 Point, per foot | \$0 25 | \$0 15 | 10 Point, per foot | \$0 50 | \$0 15 |
| 6 Point, per foot | 30 | 15 | 12 Point, per foot | 60 | 15 |

NOTE.—The minimum sizes given in the Election Laws of Wisconsin are $\frac{1}{32}$ of an inch ($4\frac{1}{2}$ Points) and $\frac{1}{16}$ of an inch (9 Points).

NEW METAL BRACES

6 POINT PER FONT (two of each length) \$1 00
PER DOZEN OF ANY ONE SIZE 50 CENTS

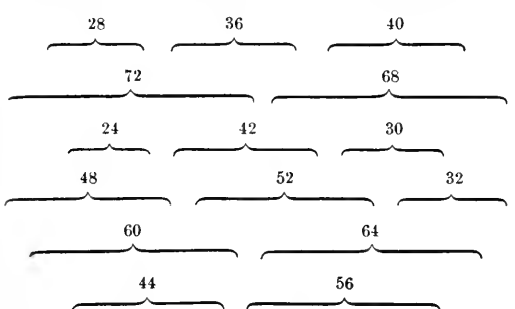

The No. also indicates the length of each Brace in points

6 POINT BRACES AND DASHES No 2

PRICE PER FONT \$1 25

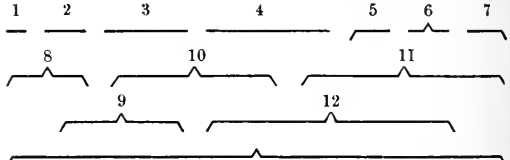

Nos. 8 to 12 are complete; Nos. 1 to 7 are for piecing.

6 POINT METAL BRACES

PRICE PER FONT \$1 00

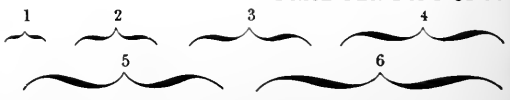

STEEL CUTTING AND SCORING RULE

| | Cutting Scoring | | | Cutting Scoring | |
|--------------------------------------|-----------------|--------|--------------------------------------|-----------------|--------|
| 2 Point, soft, per foot | \$0 10 | \$0 10 | 3 Point, hard and polished, per foot | \$0 30 | \$0 30 |
| 2 Point, hard, unpolished, per foot | 15 | 15 | 6 Point, soft, per foot | 25 | 25 |
| 2 Point, hard and polished, per foot | 25 | 25 | 6 Point, hard and polished, per foot | 50 | 50 |
| 3 Point, soft, per foot | 15 | 15 | | | |

METAL CORNER QUADS

These insure a better junction of mitered corners, by preventing them from slipping past each other.

| | |
|-------------------------------------|--------|
| 6 Point, per set of four | \$0 20 |
| 12 Point, per set of four | 20 |

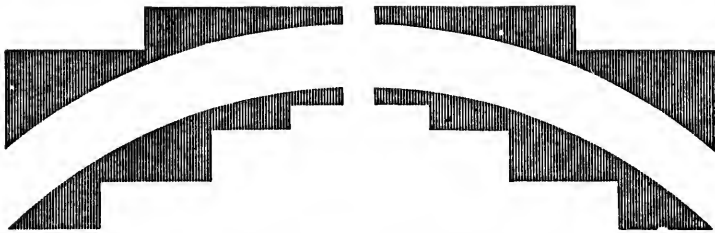

CIRCULAR QUADS

Per font, \$3.50

Each font is put up in a wooden box, containing four pieces each of twenty different curves. Each curve mortised as shown in examples.

ANGULAR QUADS

These Quads, introduced by us, are for setting rules and lines at an angle. When there is occasion for their use they are invaluable time-savers. They are of ordinary space and quad height.

Fonts, four of all sizes . . . \$1 50

Price, per set of four:

| | |
|---------------------|---------------------|
| 12 Point . . \$0 20 | 48 Point . . \$0 30 |
| 18 Point . . 20 | 60 Point . . 35 |
| 24 Point . . 20 | 72 Point . . 40 |
| 36 Point . . 25 | |

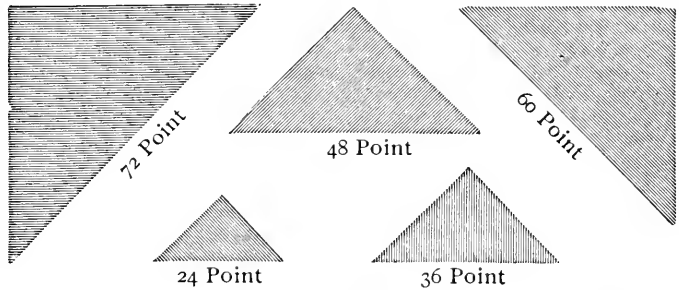

COPPER ALLOY TAKE SLUGS

The only Take Slug cast in a mould in extra durable copper alloy metal. Better, cheaper and more durable than electrotyped slugs. Any number, from 1 to 100, in this style figure only:

1 2 3 4 5 6

Price, each, 15 cents.

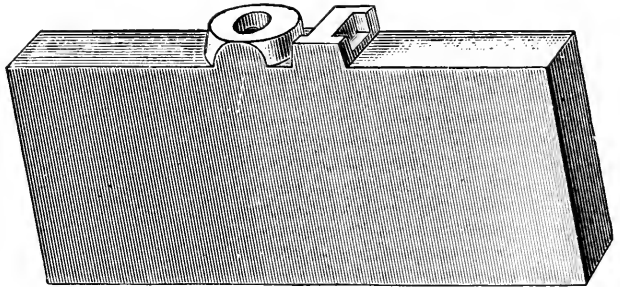

ELECTROTYPED TAKE SLUGS

With Word, Letter or Figure each, net, \$0 25

FOOT SLUGS

| | Single Column | Double Column | | Single Column | Double Column |
|---------------------------|---------------|---------------|---------------------------|---------------|---------------|
| 12 Point, Brass | \$0 15 | \$0 25 | 12 Point, Metal | \$0 04 | \$0 06 |
| 18 Point, Brass | 20 | 30 | 18 Point, Metal | 05 | 07 |
| 24 Point, Brass | 25 | 35 | 24 Point, Metal | 06 | 08 |

LIST PRICE OF LEADS AND SLUGS

| | Uncut | Cut 8 ems Pica and longer, and Labor-Saving Fonts | Cut shorter than 8 ems |
|--|--------|---|------------------------|
| 1 Point (12-to-Pica), per lb. | \$0 50 | \$0 64 | \$0 68 |
| 1½ Point (10-to-Pica), per lb. | 40 | 50 | 54 |
| 1¾ Point (8-to-Pica), per lb. | 32 | 40 | 44 |
| 2 Points and thicker, per lb. | 16 | 20 | 25 |

METAL FURNITURE

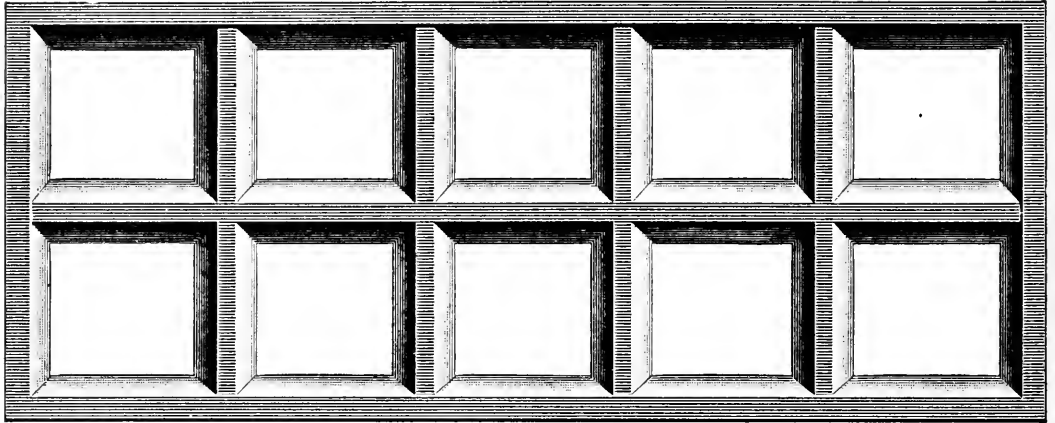

Put up in fonts containing the following sizes: 2, 3, 4, 5, 6, 8 and 10 ems Pica wide, and 4, 5, 6, 8, 10, 15, 20, 25, 30 and 50 ems Pica long.

| | | | |
|-------------------------|--------|--------------------------|---------|
| 12 pound font | \$3 00 | 50 pound font | \$12 50 |
| 25 pound font | 6 25 | 100 pound font | 25 00 |

Attention is invited to the new design of this furniture. The strain-bearing braces have been increased in number and placed in the best possible positions, increasing the strength while not increasing the weight.

LABOR-SAVING QUOTATION FURNITURE

Finished with the strictest regard for accuracy. Made 2, 3 and 4 ems Pica wide, and 4, 8, 12, 16 and 20 ems Pica long. If desired, furnished in lengths from 20 ems to 80 ems, graduated by 4 ems. Regular fonts do not contain pieces longer than 20 ems.

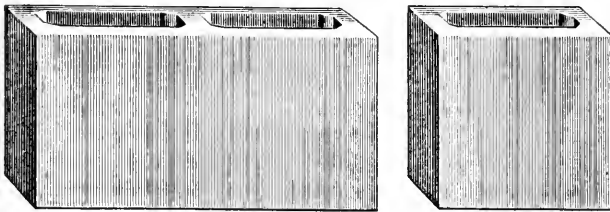

| | |
|--------------------------|---------|
| 12 pound font | \$ 3 00 |
| 25 pound font | 6 25 |
| 50 pound font | 12 50 |
| 100 pound font | 25 00 |

FOLLOWING SIZES CAST TO ORDER ONLY:

Additional small sizes, 2 x 5, 2 x 6, 3 x 5, 3 x 6, 4 x 5, 4 x 6, 5 x 5, 5 x 6 and 6 x 6, cast accurately to Pica ems. Additional long sizes, 2, 3, 4 and 5 ems Pica wide by 10, 12, 15, 18, 24, 25, 30, 35, 36, 40, 42, 45, 48, 50, 54, 55, 60, 65, 66, 70, 72, 75, 78 and 80 ems Pica long; also, 6 ems Pica wide by 12, 18, 24, 30, 36, 42, 48, 54, 60, 66, 72 and 78 ems Pica long. Price, per pound, 25 cents.

REVERSIBLE METAL FURNITURE

This Labor-Saving Reversible Furniture is the strongest and one of the most accurate. It is made on the Point System of Bodies, and is useful for blanking out and making up forms and for general imposition. List of sizes furnished: 2, 3, 4, 5, 6, 7 and 10 ems Pica in width, and 4, 5, 6, 8, 10, 15, 20 and 25 ems Pica in length; also 2, 3, 4 and 5 ems in width by 50 ems in length. Fonts of 50 pounds or more in weight contain all of the above sizes.

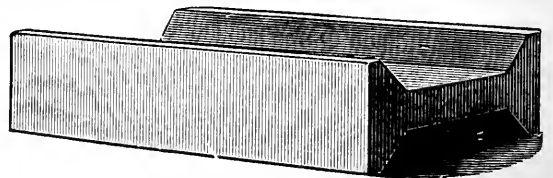

| | | | |
|----------------------------|-----------------------------|-----------------------------|------------------------------|
| 25 pound font . . . \$6 25 | 50 pound font . . . \$12 50 | 75 pound font . . . \$18 75 | 100 pound font . . . \$25 00 |
|----------------------------|-----------------------------|-----------------------------|------------------------------|

PART XV.

*Borders and
Ornaments*

HALF NONPAREIL BORDERS

COMPLETE FONT \$2 25 10 FEET LONG

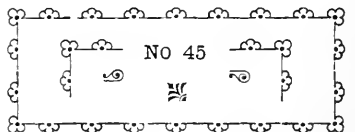
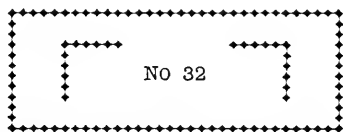
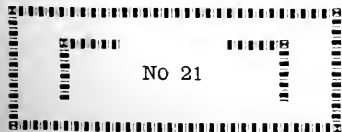
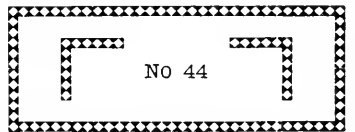
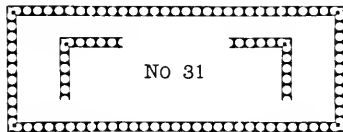
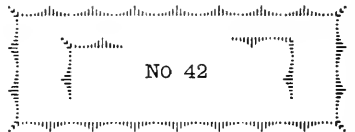
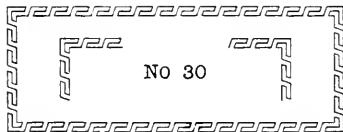
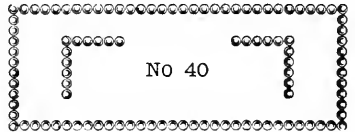
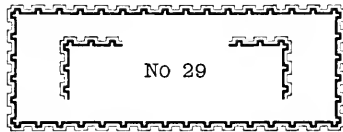
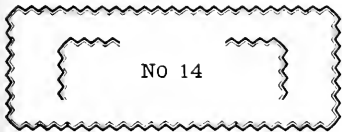
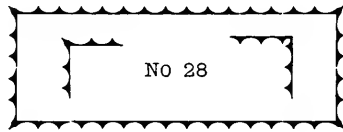
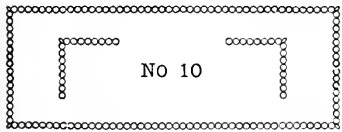
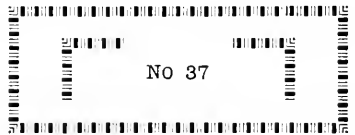
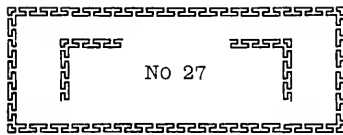
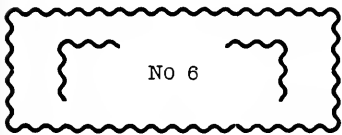
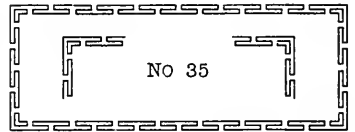
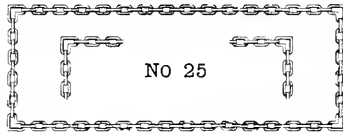
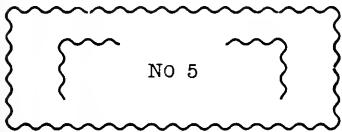
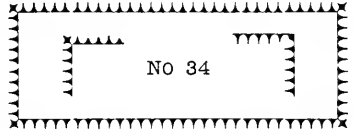
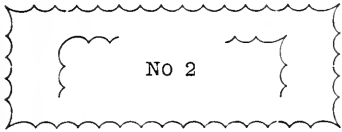
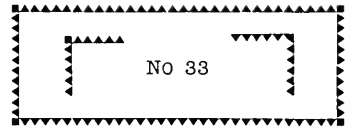
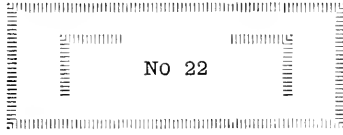
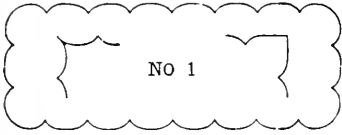

NONPAREIL BORDERS

COMPLETE FONT \$2 60 10 FEET LONG

HALF FONT \$1 40 5 FEET LONG

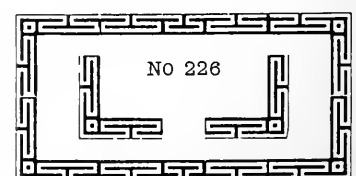
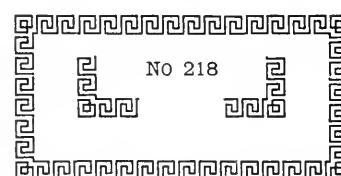
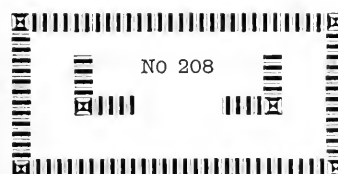
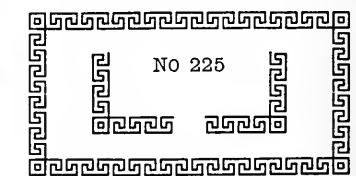
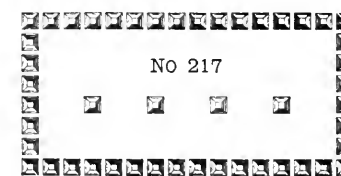
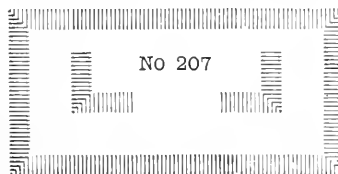
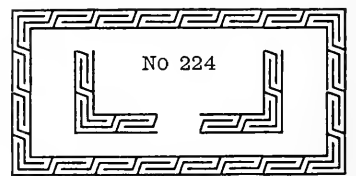
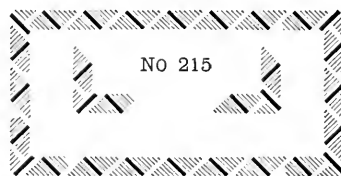
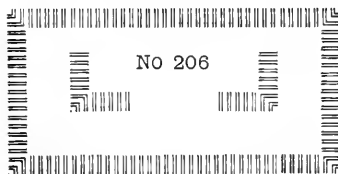
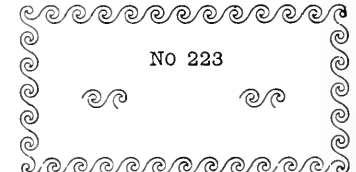
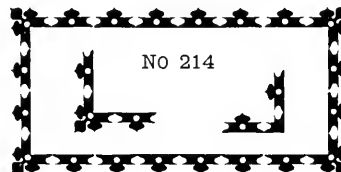
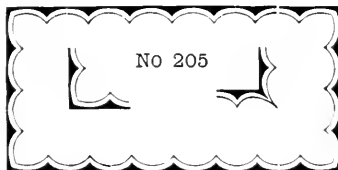
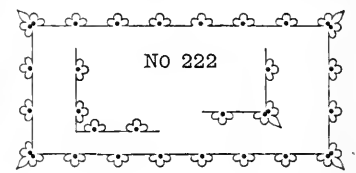
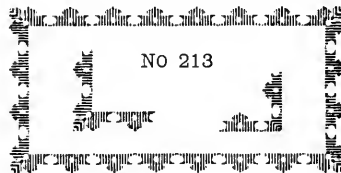
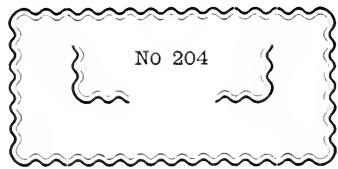
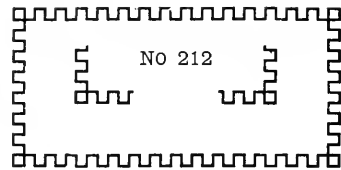
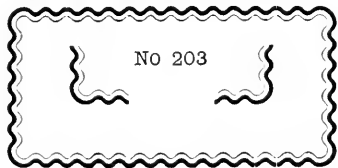
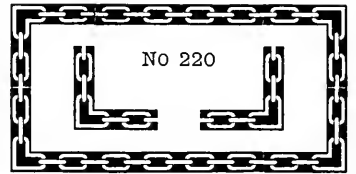
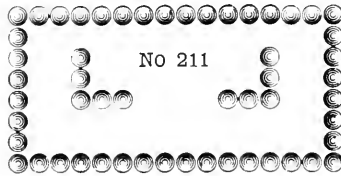
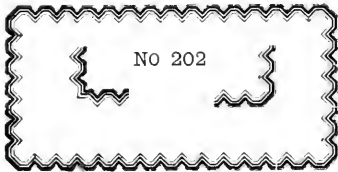
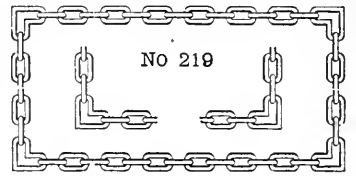
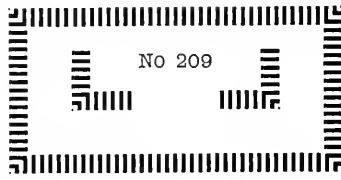
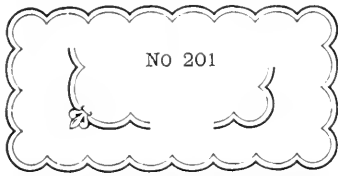

NONPAREIL BORDERS

COMPLETE FONT \$2 60 10 FEET LONG

HALF FONT \$1 40 5 FEET LONG

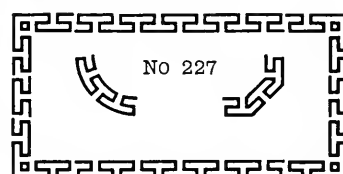
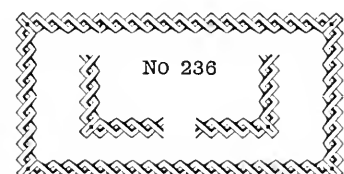
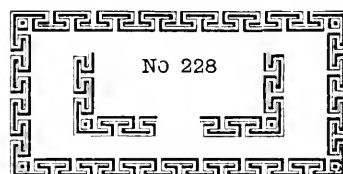
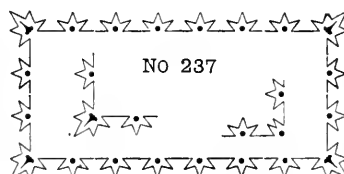
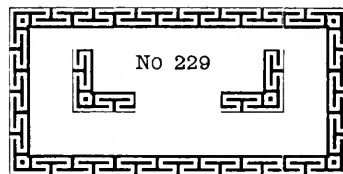
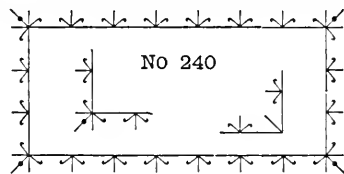
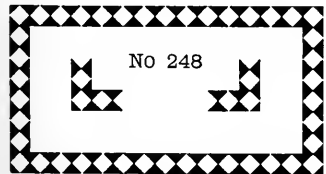
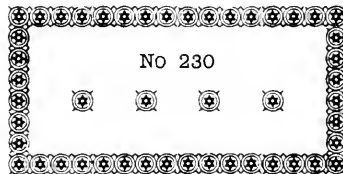
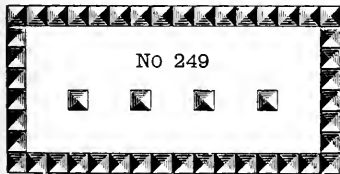
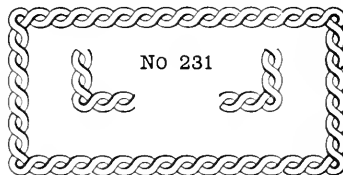
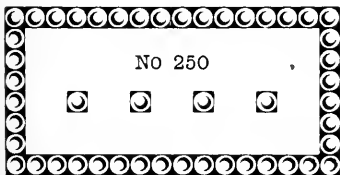
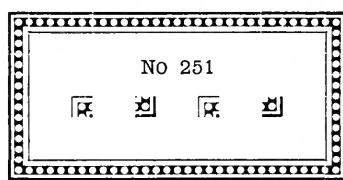
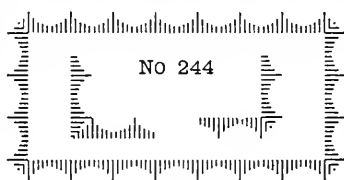
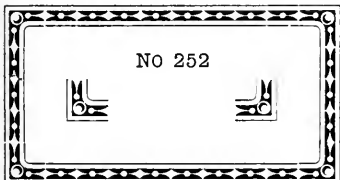
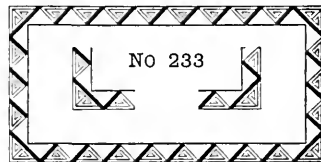
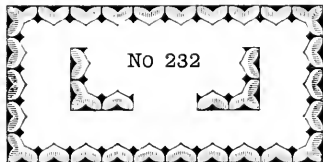
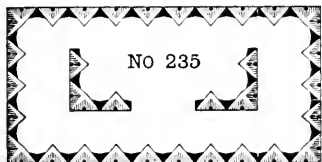
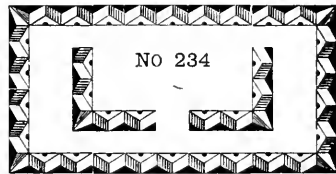
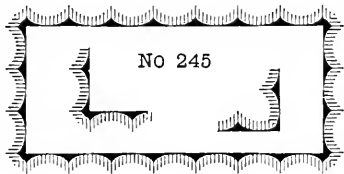
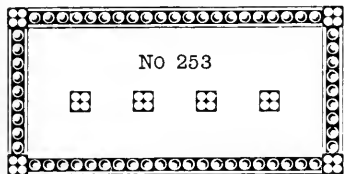

NONPAREIL AND ONE-HALF BORDERS

COMPLETE FONT \$3 00 10 FEET LONG

HALF FONT \$1 60 5 FEET LONG

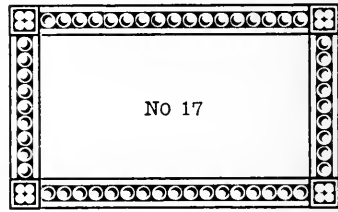
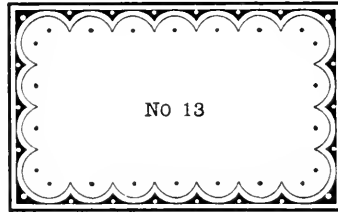
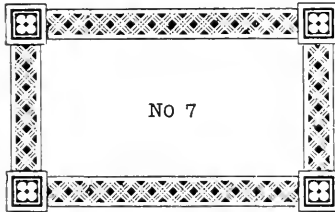
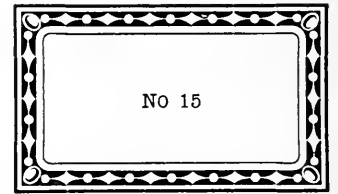
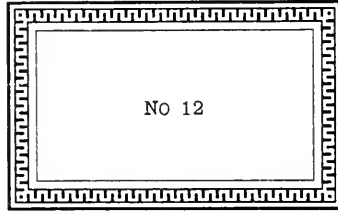
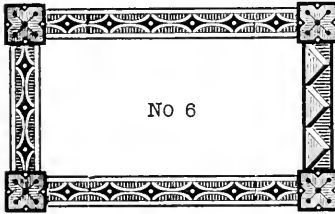
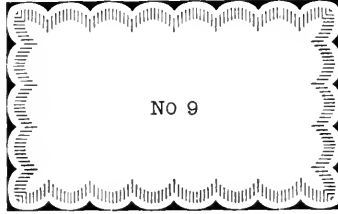
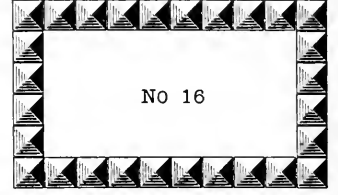
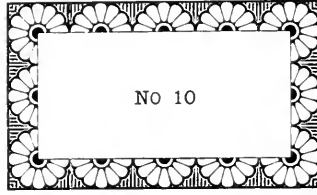
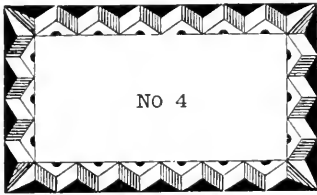

PICA BORDERS

COMPLETE FONT \$3 00 10 FEET LONG

HALF FONT \$1 60 5 FEET LONG

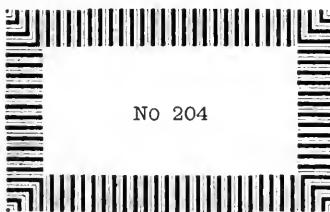
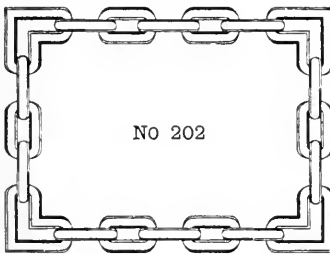

PICA BORDERS

COMPLETE FONT \$3 00 10 FEET LONG

HALF FONT \$1 60 5 FEET LONG

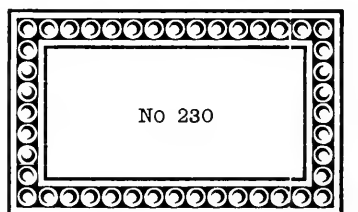
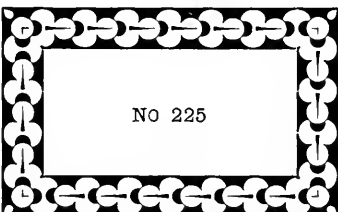
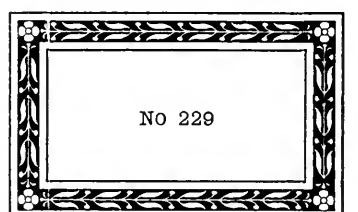
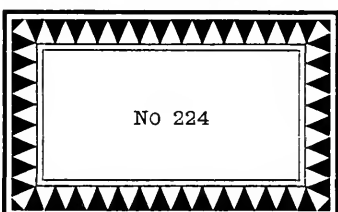
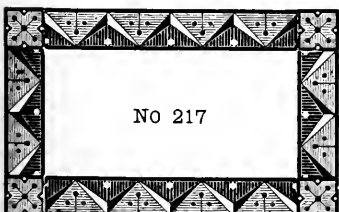
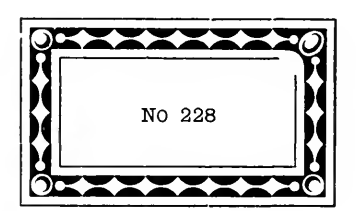
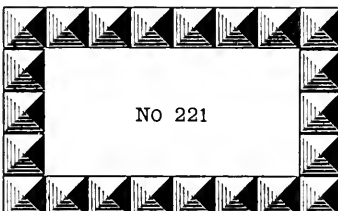
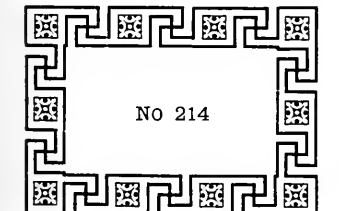
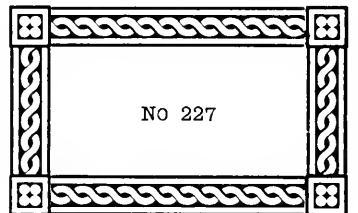
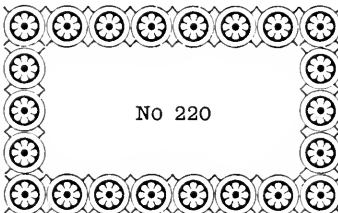
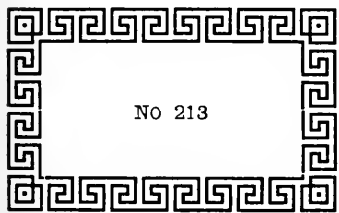
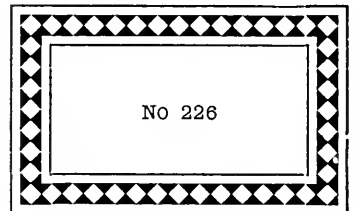
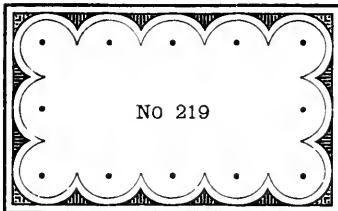
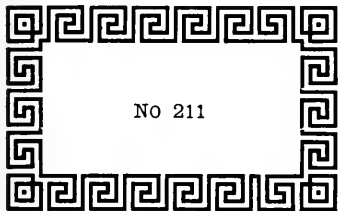
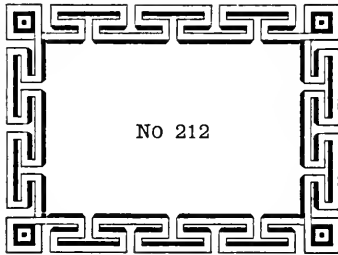

3-LINE NONPAREIL, 2- AND 3-LINE PICA BORDERS

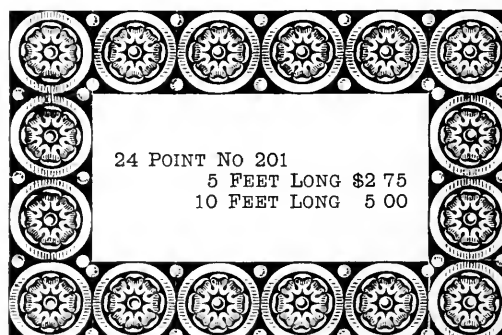
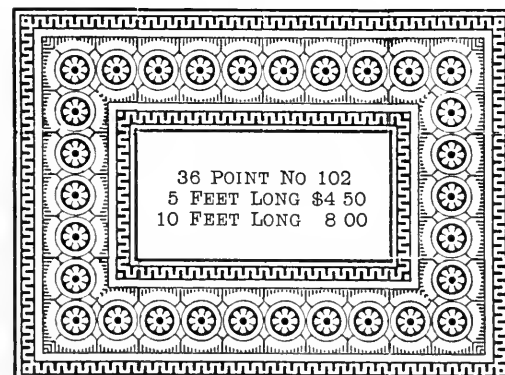
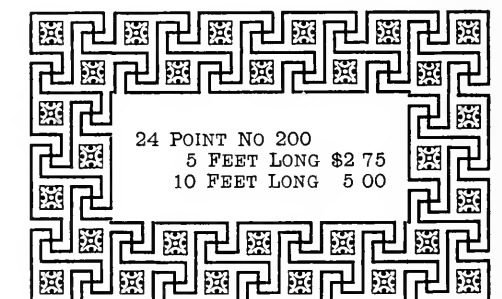
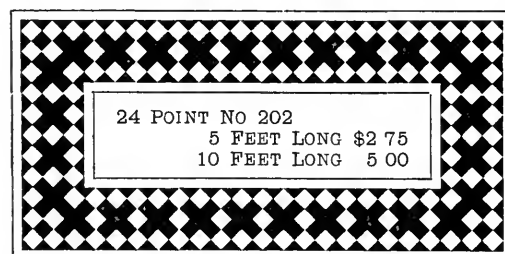
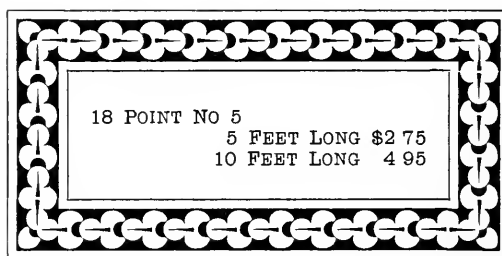
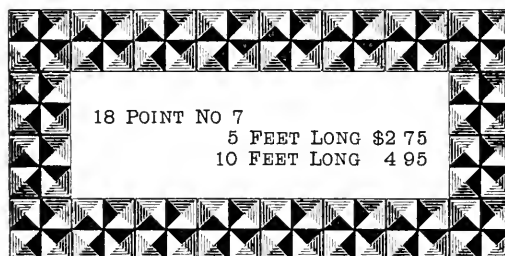
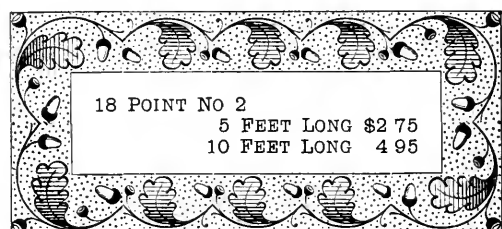
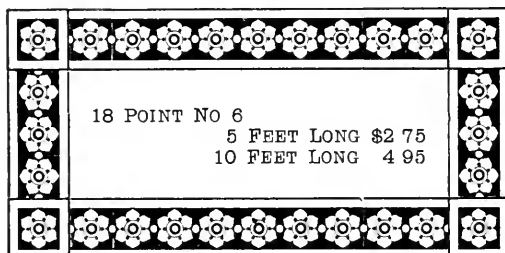
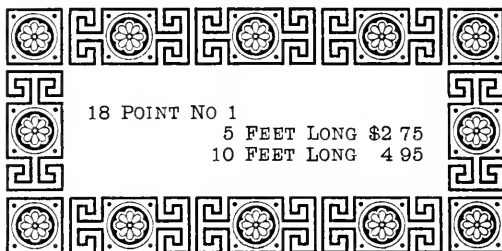
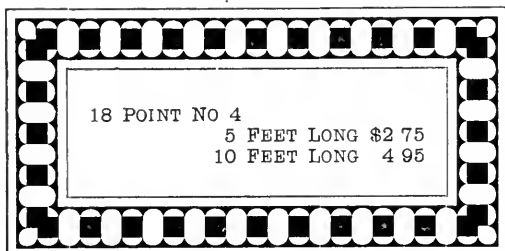

ART BORDERS

These Borders are made to register for two colors. See page 75b

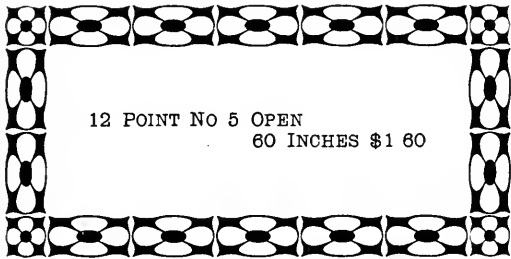

12 POINT NO 5 OPEN
60 INCHES \$1 60

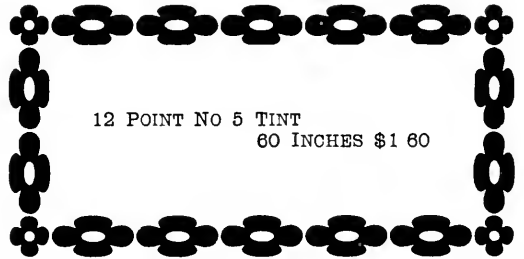

12 POINT NO 5 TINT
60 INCHES \$1 60

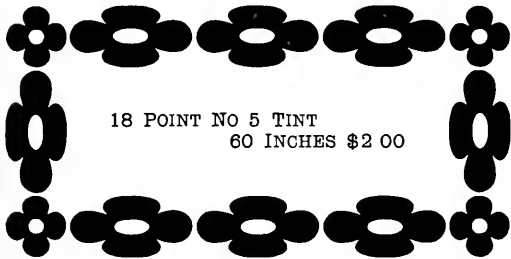

18 POINT NO 5 TINT
60 INCHES \$2 00

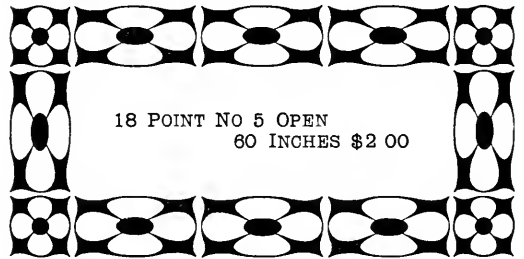

18 POINT NO 5 OPEN
60 INCHES \$2 00

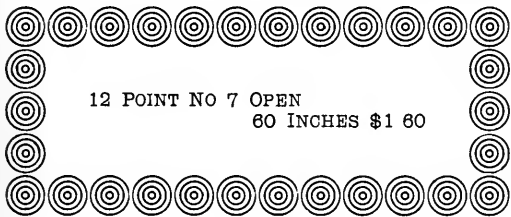

12 POINT NO 7 OPEN
60 INCHES \$1 60

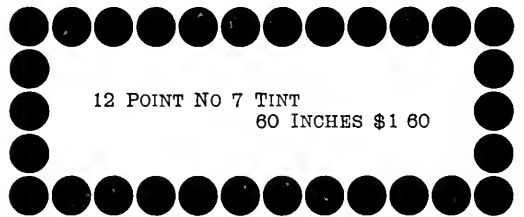

12 POINT NO 7 TINT
60 INCHES \$1 60

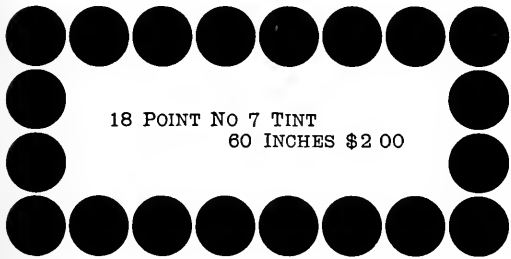

18 POINT NO 7 TINT
60 INCHES \$2 00

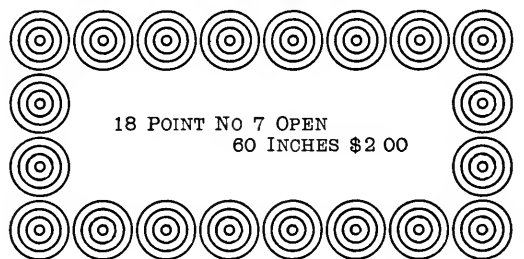

18 POINT NO 7 OPEN
60 INCHES \$2 00

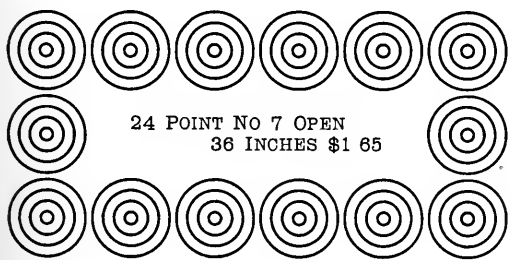

24 POINT NO 7 OPEN
36 INCHES \$1 65

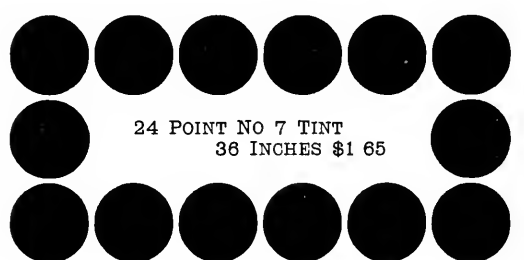

24 POINT NO 7 TINT
36 INCHES \$1 65

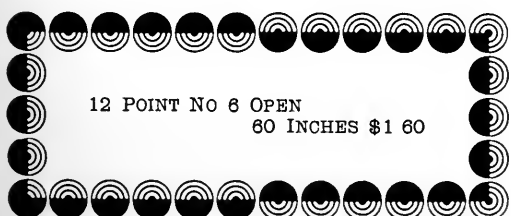

12 POINT NO 8 OPEN
60 INCHES \$1 60



18 POINT NO 8 OPEN
60 INCHES \$2 00

ART BORDERS

These Borders are made to register for two colors. See page 756

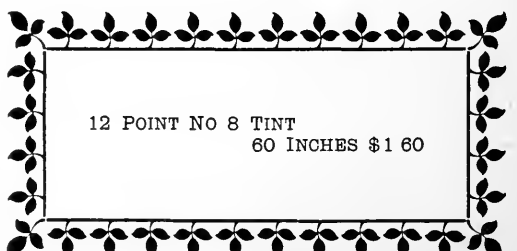
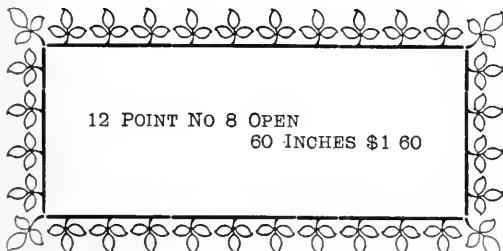
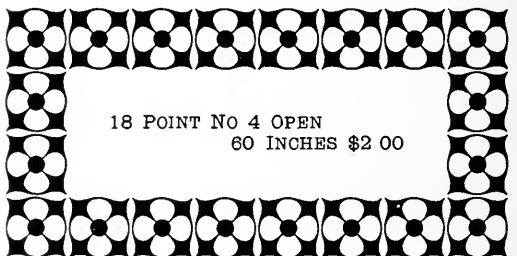
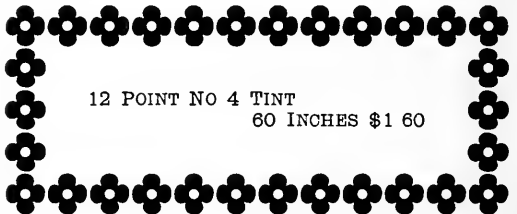
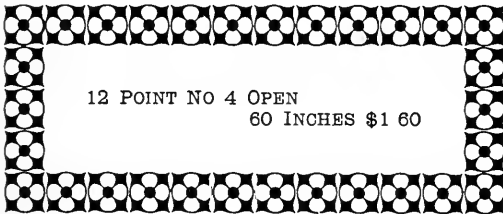
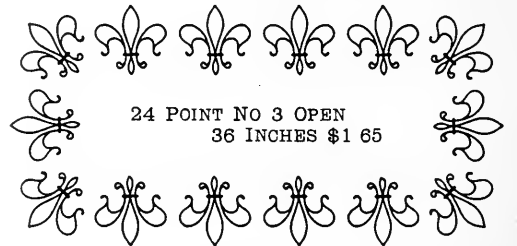
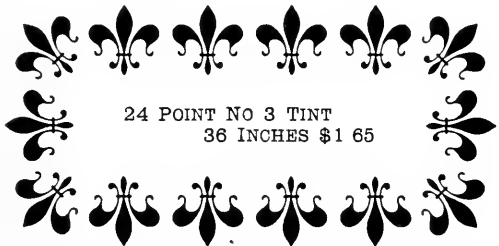
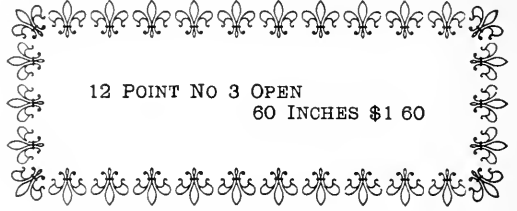

ART BORDERS

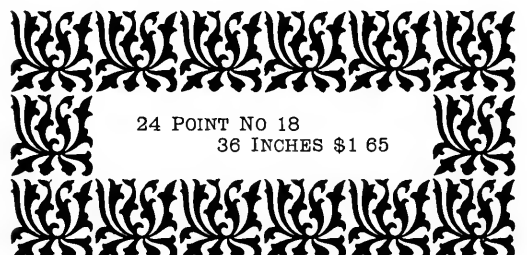
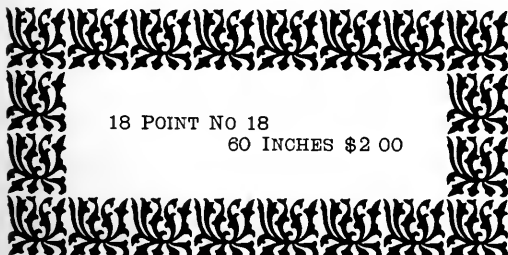
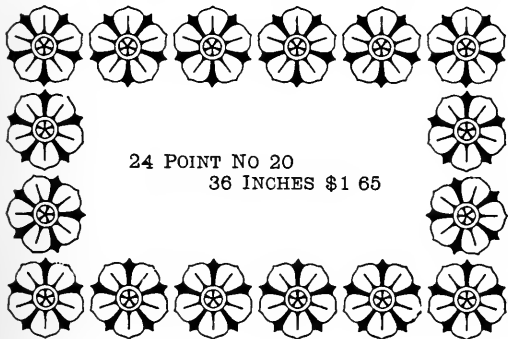
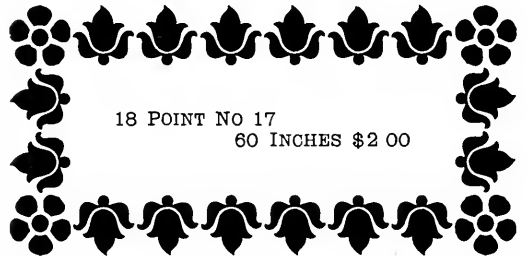
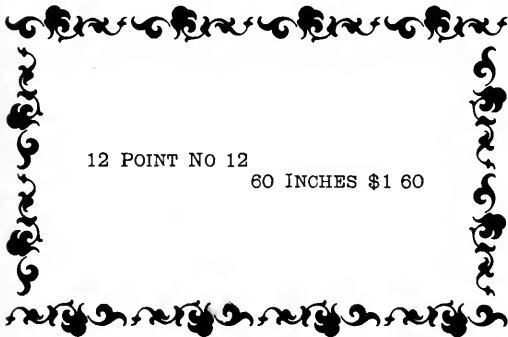
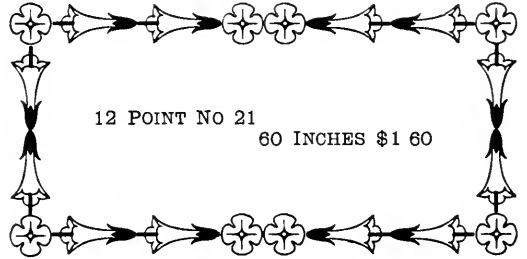
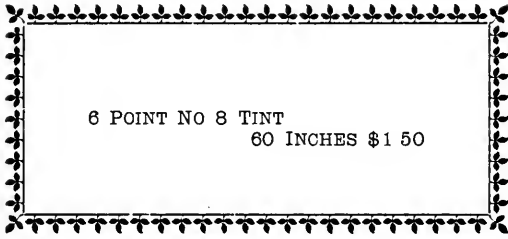

ART BORDERS

Art Borders Nos. 6, 9 and 10, all sizes, are made to register for two colors. See page 756

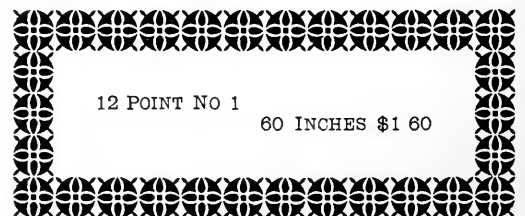
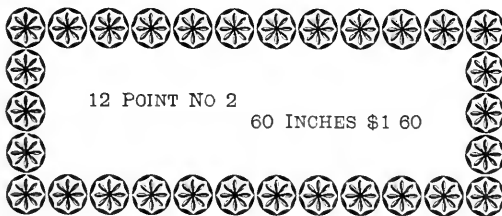
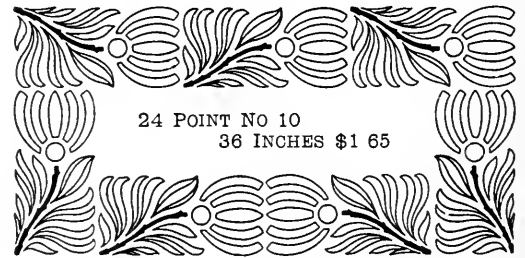
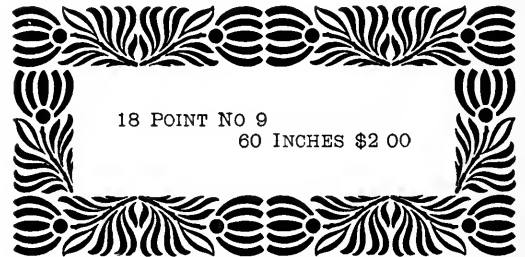
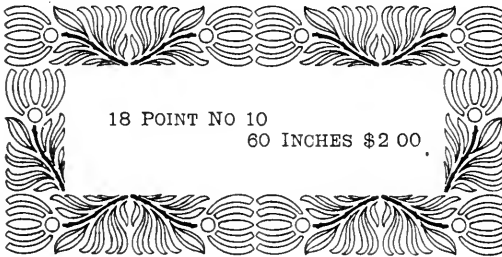
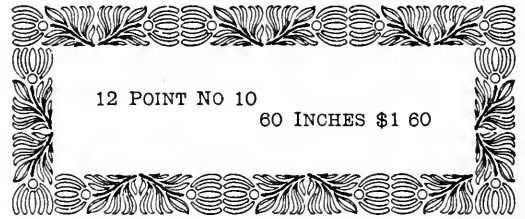
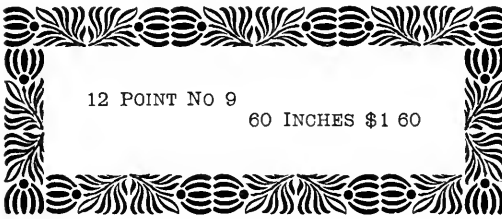
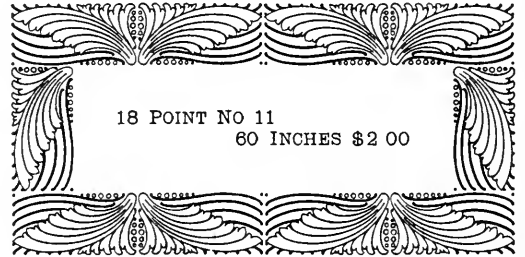
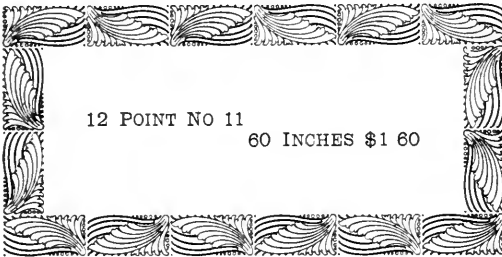
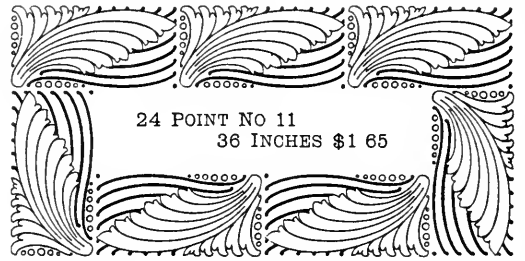
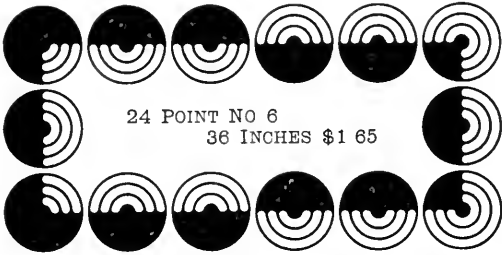

ART BORDERS

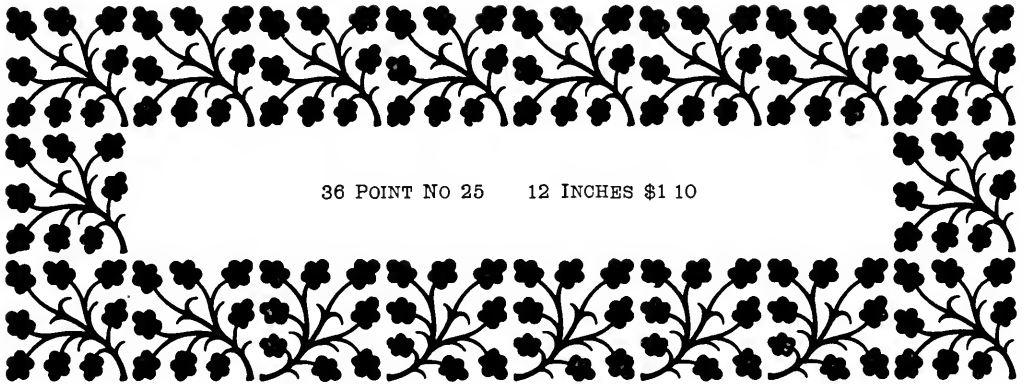

36 POINT NO 25 12 INCHES \$1 10

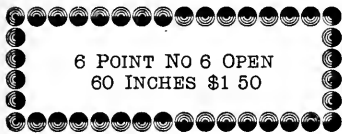

6 POINT NO 6 OPEN
60 INCHES \$1 50

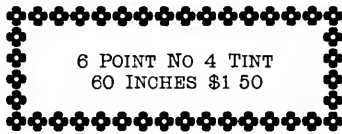

6 POINT NO 4 TINT
60 INCHES \$1 50

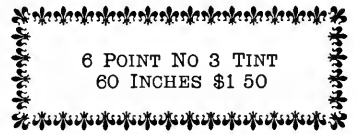

6 POINT NO 3 TINT
60 INCHES \$1 50

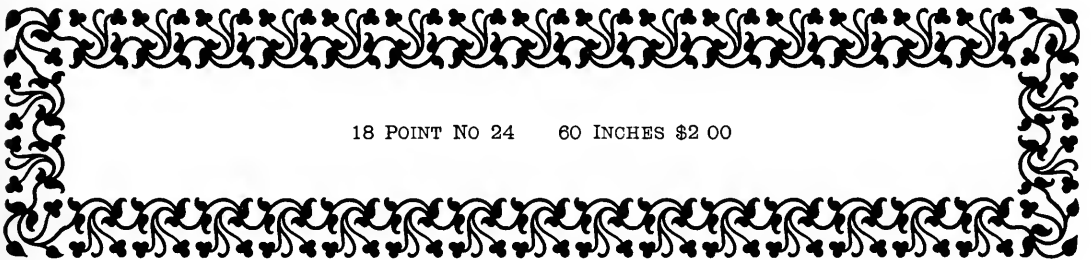

18 POINT NO 24 60 INCHES \$2 00

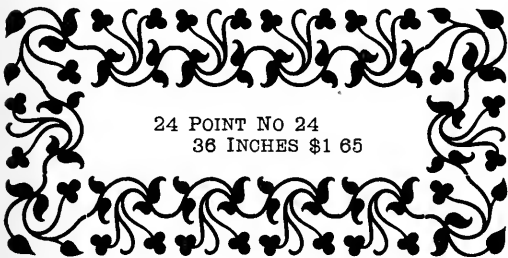

24 POINT NO 24
36 INCHES \$1 65



24 POINT NO 25
36 INCHES \$1 65

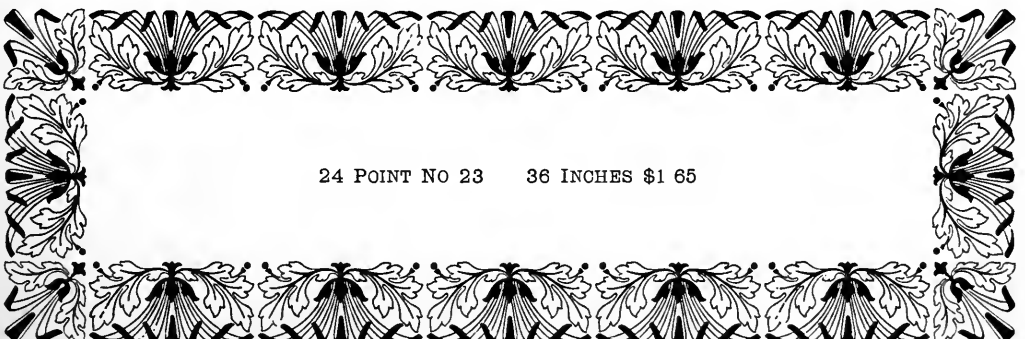

24 POINT NO 23 36 INCHES \$1 65

ART BORDERS

18 POINT NO 25

60 INCHES \$2 00

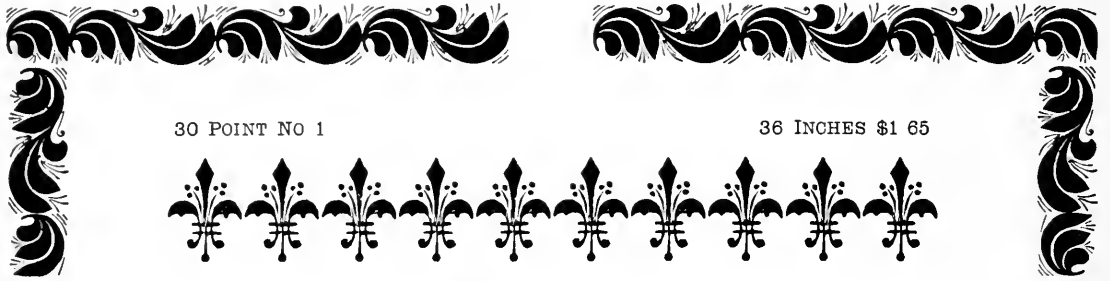

CENTRAL BANDS

12 POINT NO 1 24 INCHES 75 CENTS

12 POINT NO 2 24 INCHES 75 CENTS



18 POINT NO 1 24 INCHES \$1 00

18 POINT NO 2 24 INCHES \$1 00



24 POINT NO 1 24 INCHES \$1 50

24 POINT NO 2 24 INCHES \$1 50



POLKA-DOT BORDER

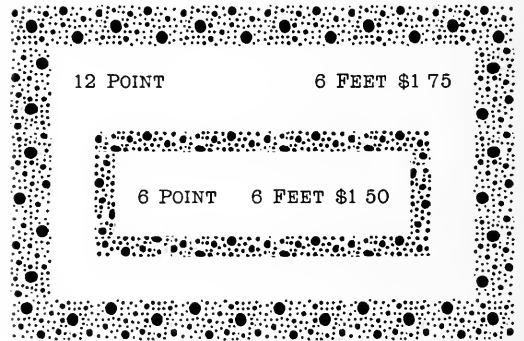
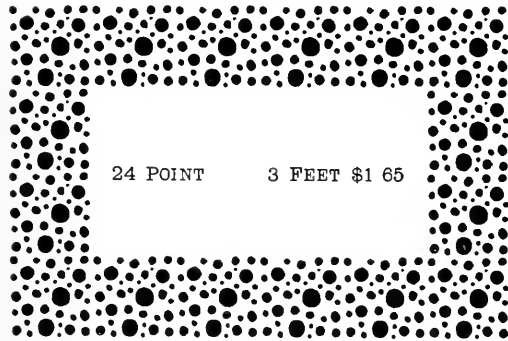

RUSTIC BAND BORDER

24 POINT

3 FEET \$1 65

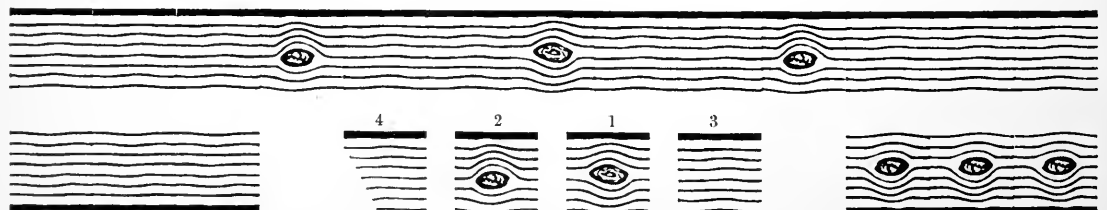

POINTER BORDERS

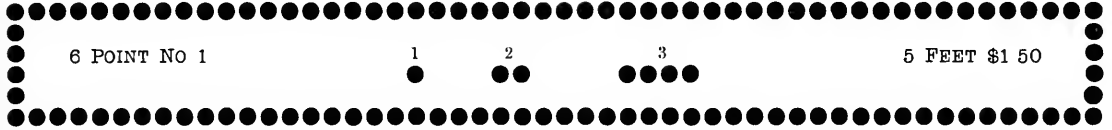
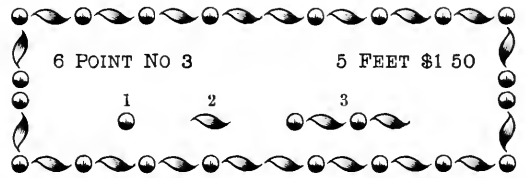
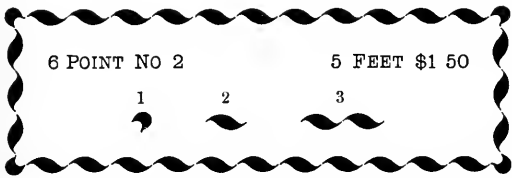

DARLING BORDERS



DAISY BORDERS

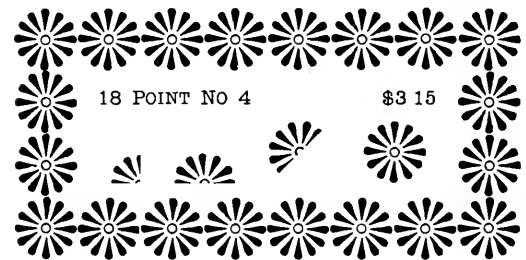
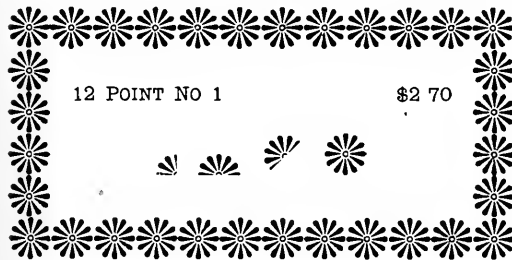
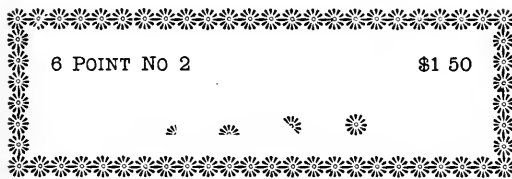

REGAL BORDERS

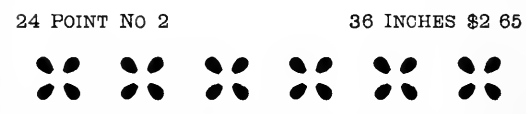
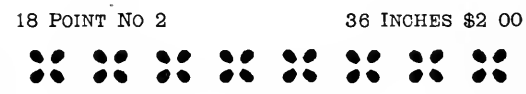

Regal Border No. 2 registers with Regal Border for color printing, see page 753

NEWSPAPER BORDERS

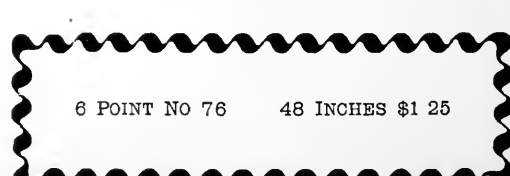
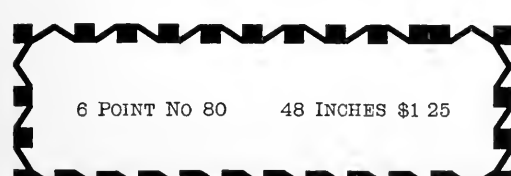
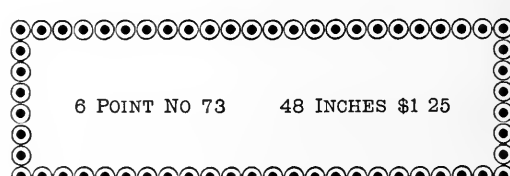
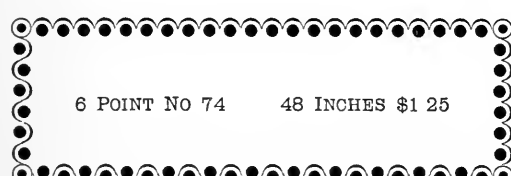
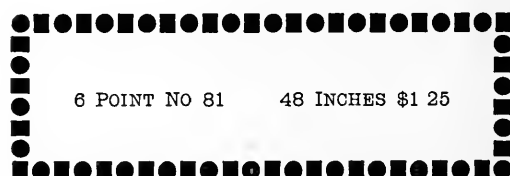
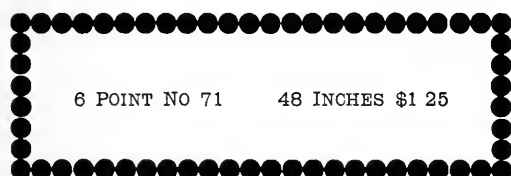
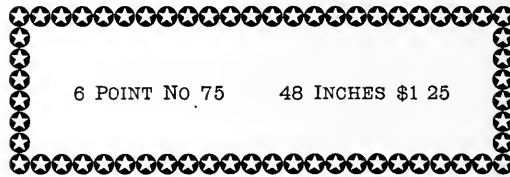
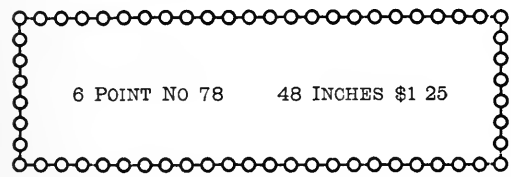
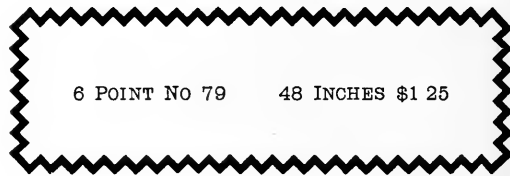
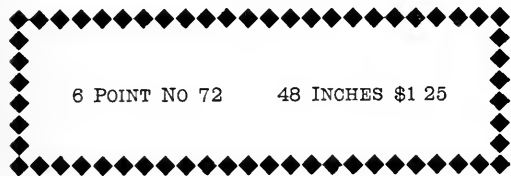
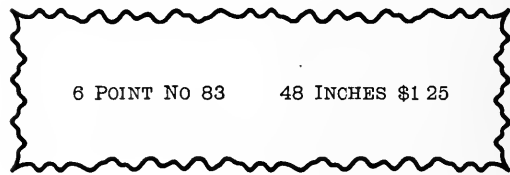
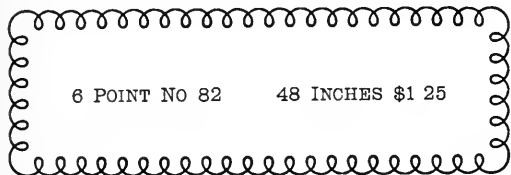
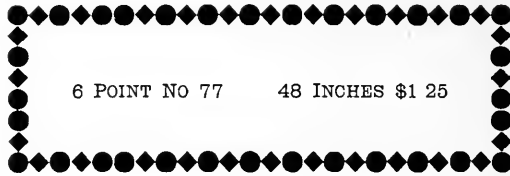
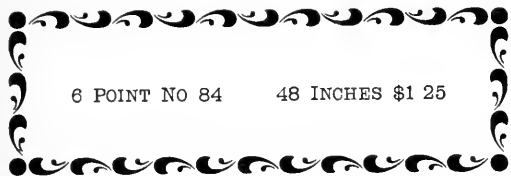

NEWSPAPER BORDERS

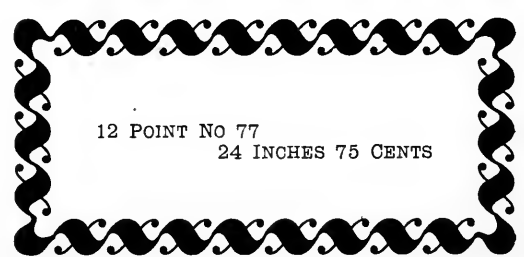
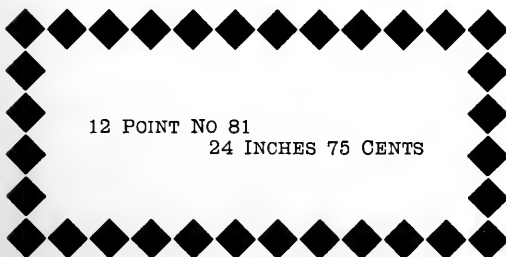
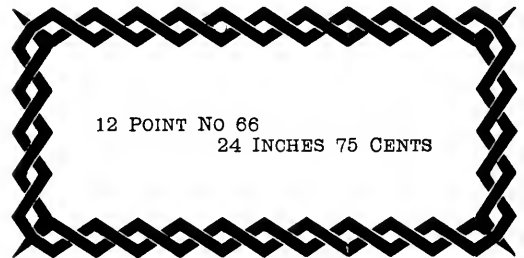
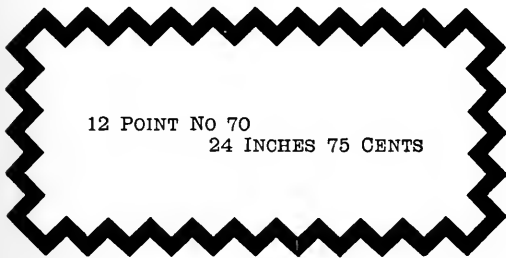
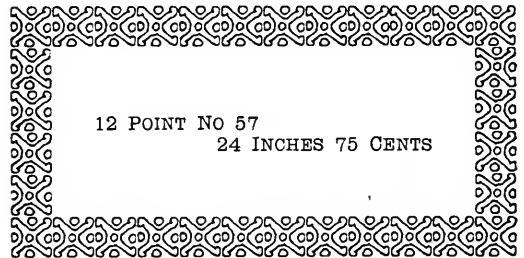
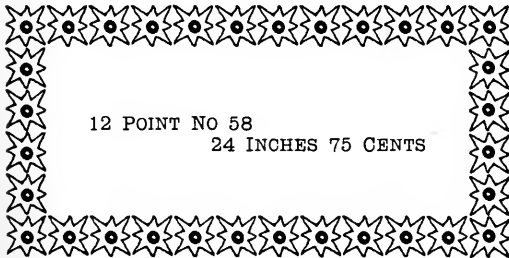
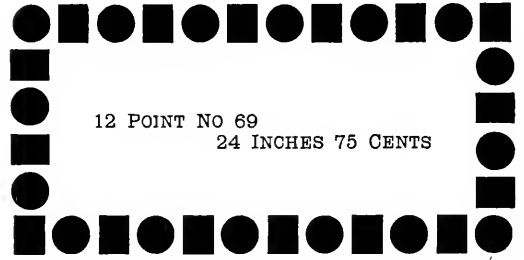
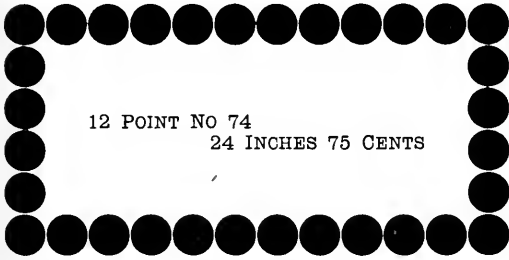
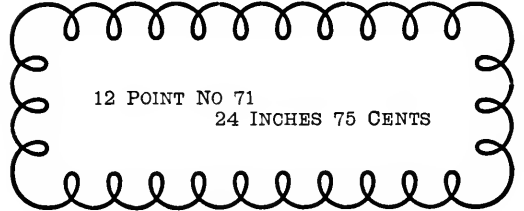
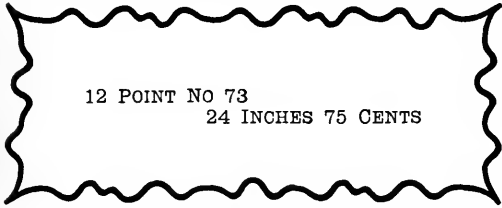
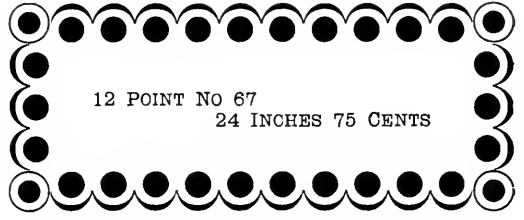
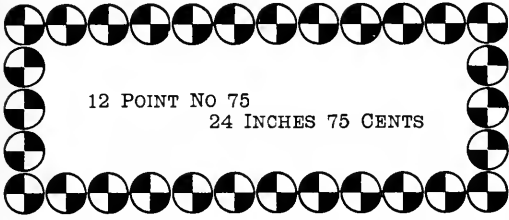

NEWSPAPER BORDERS

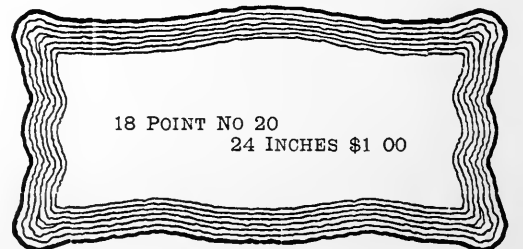
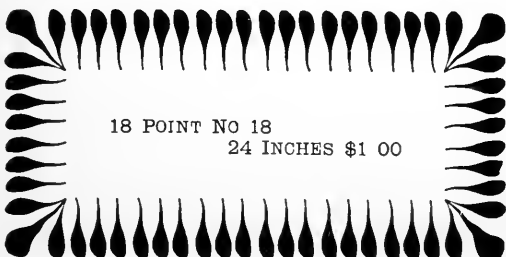
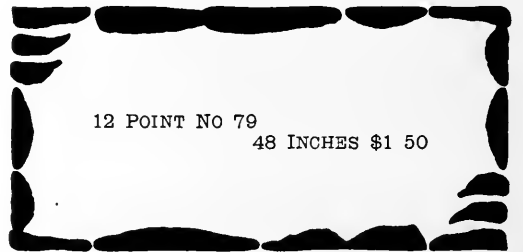
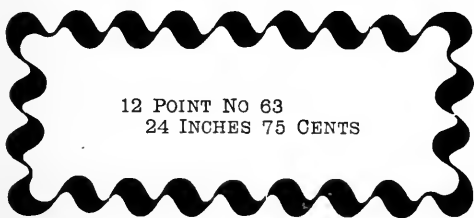
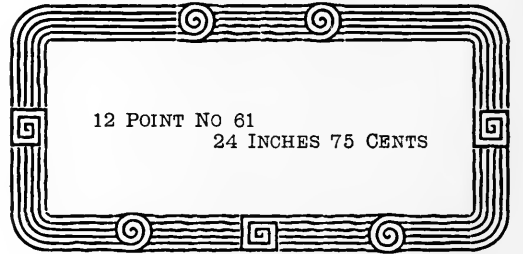
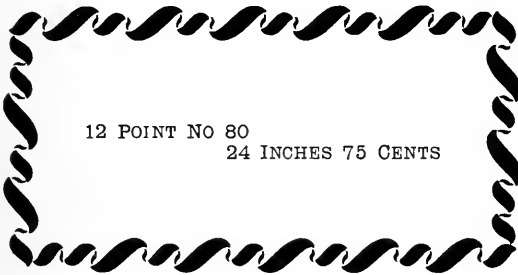
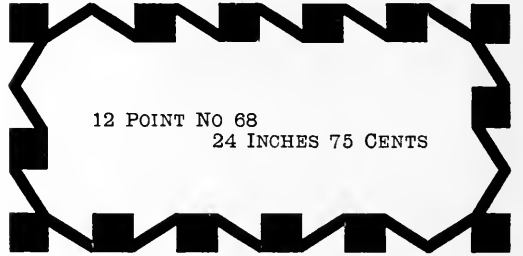
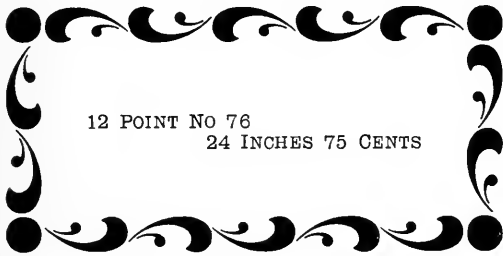
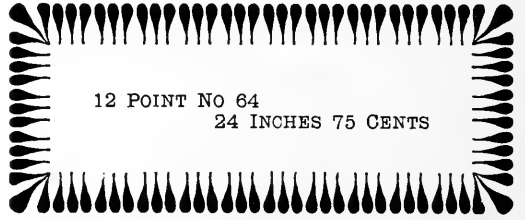
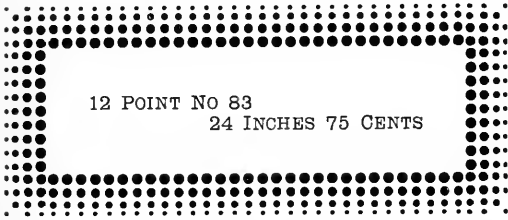
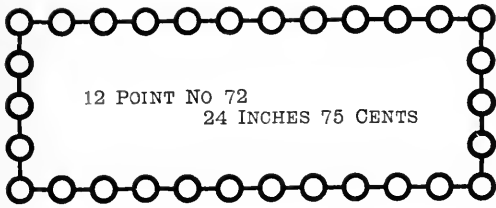

NEWSPAPER BORDERS

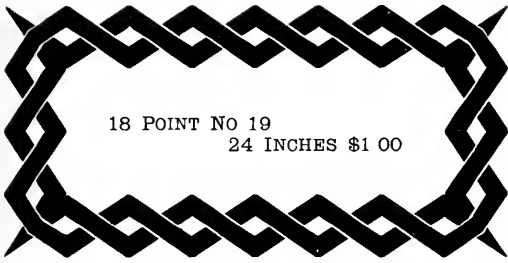

18 POINT NO 19
24 INCHES \$1 00

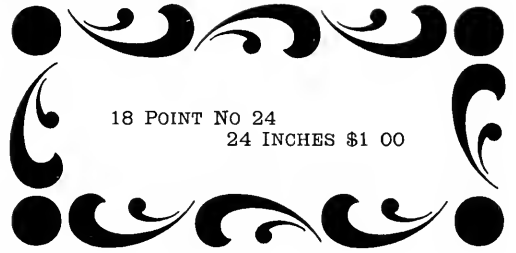

18 POINT NO 24
24 INCHES \$1 00

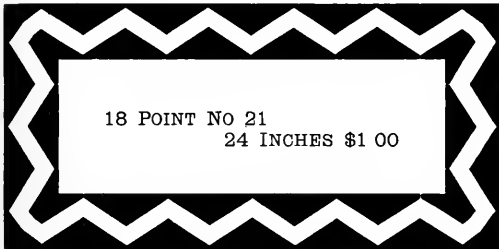

18 POINT NO 21
24 INCHES \$1 00

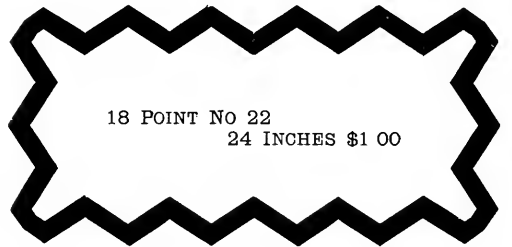

18 POINT NO 22
24 INCHES \$1 00

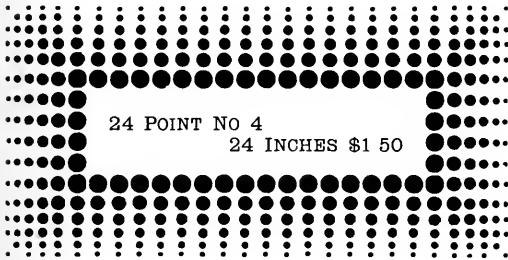

24 POINT NO 4
24 INCHES \$1 50

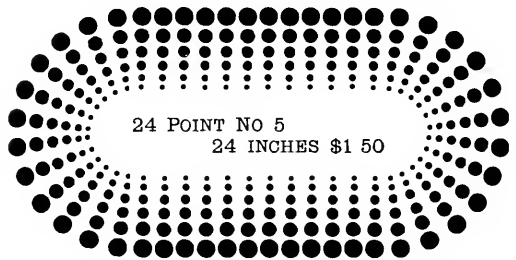

24 POINT NO 5
24 INCHES \$1 50



24 POINT NO 3
24 INCHES \$1 50

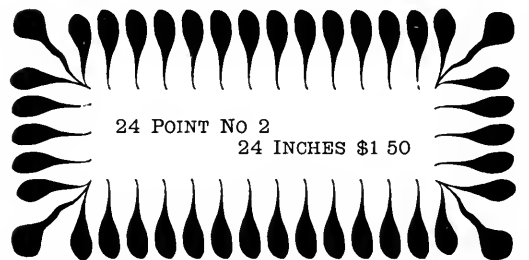

24 POINT NO 2
24 INCHES \$1 50

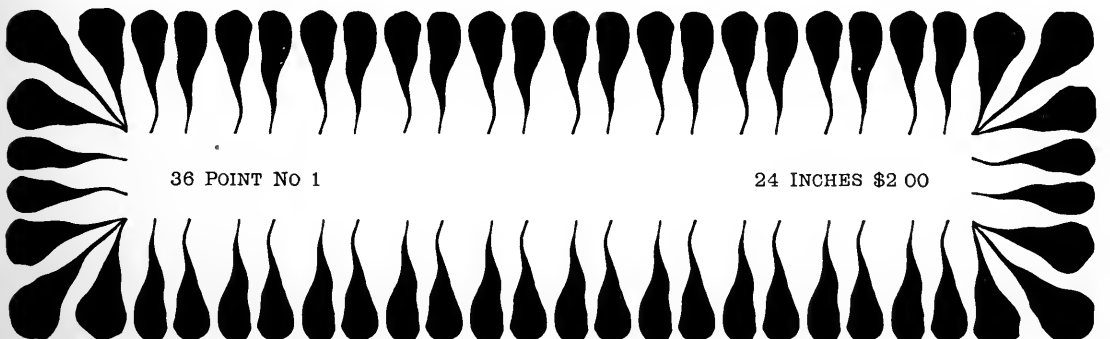

36 POINT NO 1

24 INCHES \$2 00

NEWSPAPER BORDERS

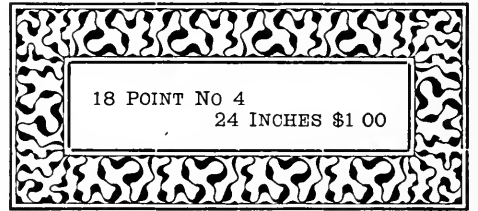
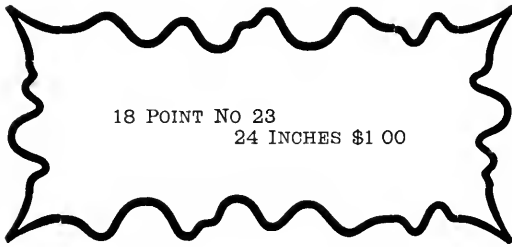
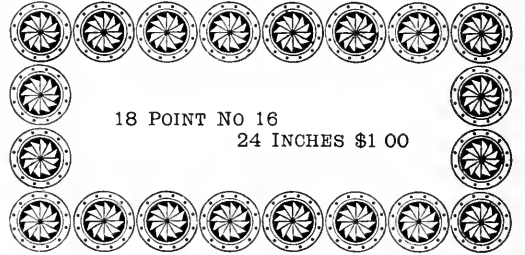
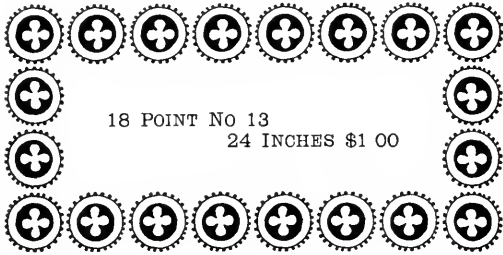
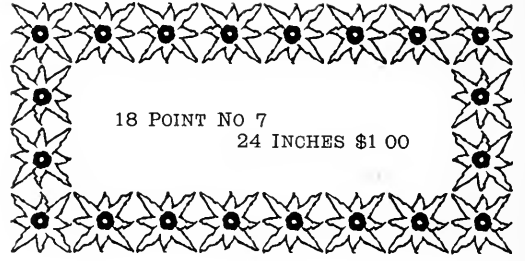
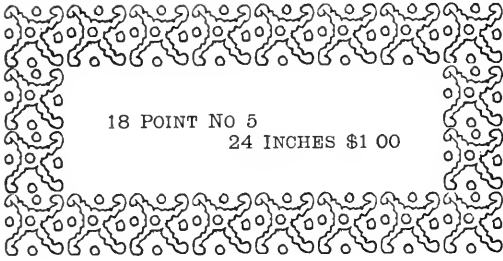

EIGHTEEN POINT BORDERS

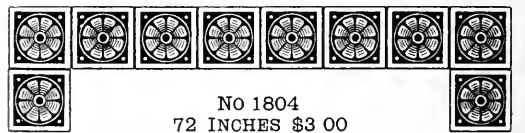

TWELVE POINT BORDERS

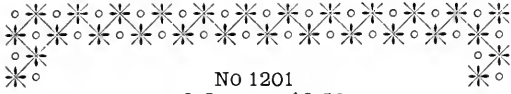

No 1201
72 INCHES \$2 50

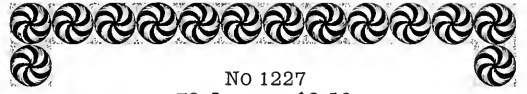

No 1227
72 INCHES \$2 50



No 1207
72 INCHES \$2 50



No 1228
72 INCHES \$2 50



No 1209
72 INCHES \$2 50



No 1232
72 INCHES \$2 50

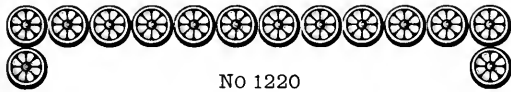

No 1220
72 INCHES \$2 50



No 1233
72 INCHES \$2 50



No 1225
72 INCHES \$2 50



No 1234
72 INCHES \$2 50

TWENTY-FOUR POINT BORDERS

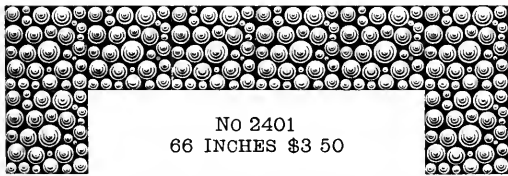

No 2401
66 INCHES \$3 50

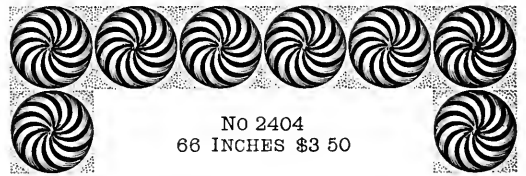

No 2404
66 INCHES \$3 50

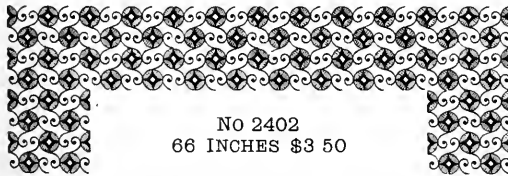

No 2402
66 INCHES \$3 50

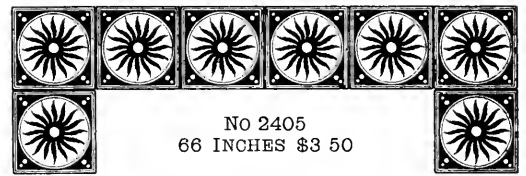

No 2405
66 INCHES \$3 50



No 2403
66 INCHES \$3 50



No 2406
66 INCHES \$3 50

COLLINS BORDERS

36 POINT NO 197

18 INCHES \$1 50

36 POINT NO 172

18 INCHES \$1 50



18 POINT NO 173 30 INCHES \$1 50



18 POINT NO 198 30 INCHES \$1 50



8 POINT NO 201 50 INCHES \$1 50

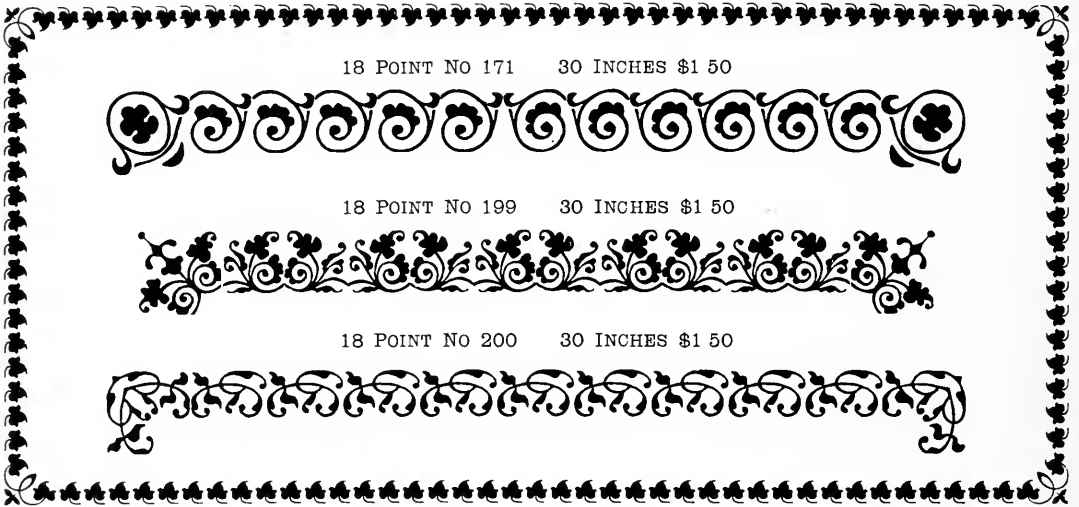

18 POINT NO 171 30 INCHES \$1 50



18 POINT NO 199 30 INCHES \$1 50



18 POINT NO 200 30 INCHES \$1 50



18 POINT NO 223 30 INCHES \$1 50



24 POINT NO 196 20 INCHES \$1 50



24 POINT NO 195
20 INCHES \$1 50

30 POINT NO 203 20 INCHES \$1 50



Several of these Borders are shown in two colors on pages 753 and 754

COLLINS BANDS

12 POINT NO 175 36 INCHES \$1 50



12 POINT NO 202 36 INCHES \$1 50



18 POINT NO 216 30 INCHES \$1 50



18 POINT NO 182 30 INCHES \$1 50



18 POINT NO 183 30 INCHES \$1 50



18 POINT NO 215 30 INCHES \$1 50



18 POINT NO 218 30 INCHES \$1 50



18 POINT NO 214 30 INCHES \$1 50



18 POINT NO 219 30 INCHES \$1 50



42 POINT NO 204 12 INCHES \$1 50



42 POINT NO 193 12 INCHES \$1 50



12 POINT NO 174 36 INCHES \$1 50



12 POINT NO 176 36 INCHES \$1 50



18 POINT NO 181 30 INCHES \$1 50



18 POINT NO 220 30 INCHES \$1 50



18 POINT NO 184 30 INCHES \$1 50



18 POINT NO 213 30 INCHES \$1 50



18 POINT NO 178 30 INCHES \$1 50



18 POINT NO 221 30 INCHES \$1 50



Several of these Bands are shown in two colors on pages 753 and 754
 Corner Pieces are not furnished with Collins Bands

COLLINS BANDS

18 POINT NO 177 30 INCHES \$1 50



18 POINT NO 212 30 INCHES \$1 50



24 POINT NO 188 20 INCHES \$1 50



24 POINT NO 186 20 INCHES \$1 50



24 POINT NO 211 20 INCHES \$1 50



24 POINT NO 217 20 INCHES \$1 50



24 POINT NO 190 20 INCHES \$1 50



24 POINT NO 208 20 INCHES \$1 50



42 POINT NO 194 12 INCHES \$1 50



48 POINT NO 205 12 INCHES \$1 50



18 POINT NO 180 30 INCHES \$1 50



18 POINT NO 179 30 INCHES \$1 50



24 POINT NO 187 20 INCHES \$1 50



24 POINT NO 185 20 INCHES \$1 50



24 POINT NO 222 20 INCHES \$1 50



24 POINT NO 206 20 INCHES \$1 50



24 POINT NO 207 20 INCHES \$1 50



24 POINT NO 189 20 INCHES \$1 50



Several of these Bands are shown in two colors on pages 753 and 754
Corner pieces are not furnished with Collins Bands

COLLINS BANDS

30 POINT No 191

20 INCHES \$1 50



30 POINT No 192

20 INCHES \$1 50



24 POINT No 209

20 INCHES \$1 50



36 POINT No 210

18 INCHES \$1 50



CAXTON BORDERS

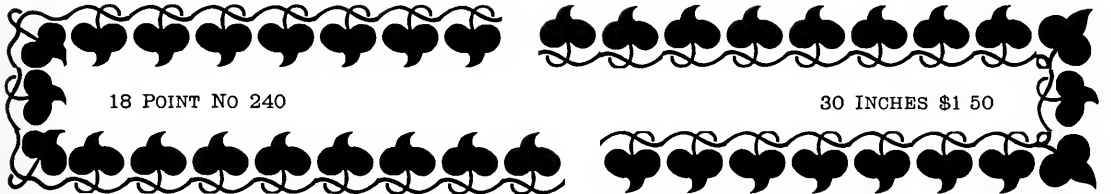

18 POINT No 240

30 INCHES \$1 50

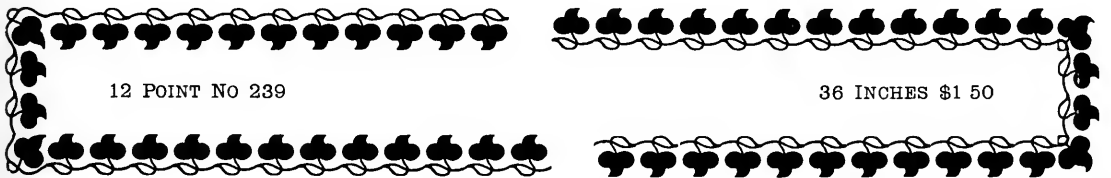

12 POINT No 239

36 INCHES \$1 50

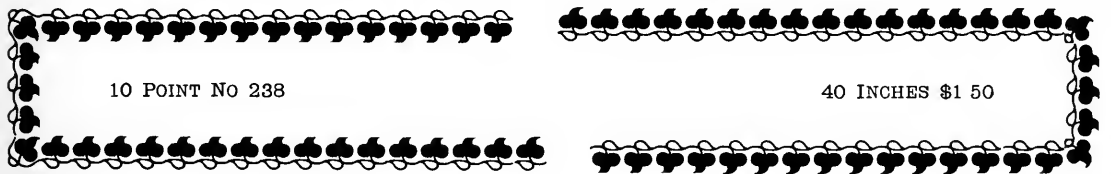

10 POINT No 238

40 INCHES \$1 50

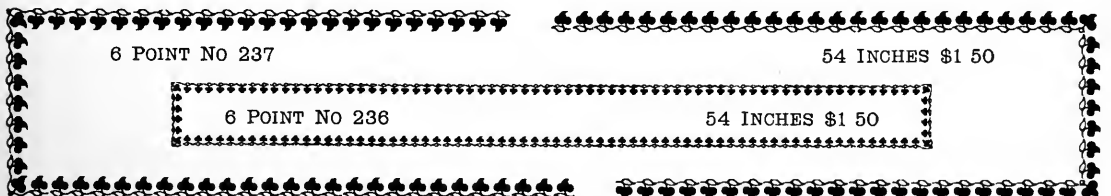

6 POINT No 237

54 INCHES \$1 50



6 POINT No 236

54 INCHES \$1 50

Two styles of corners furnished with Borders No. 237, 238, 239 and 240

FLORENTINE BORDERS

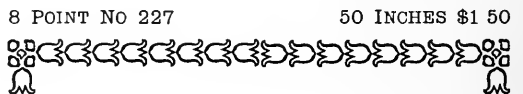
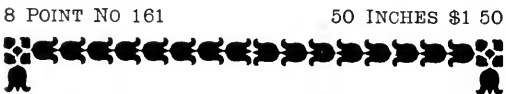
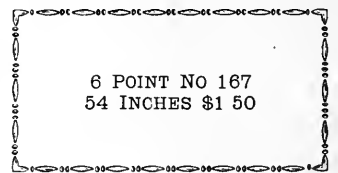
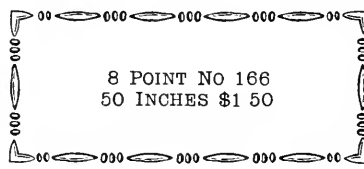
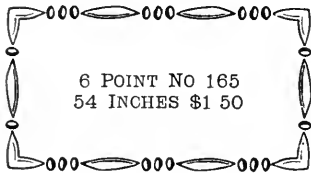
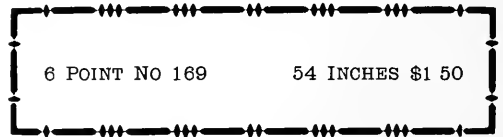
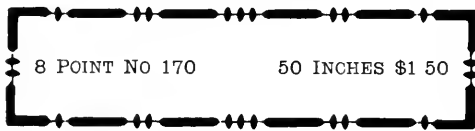
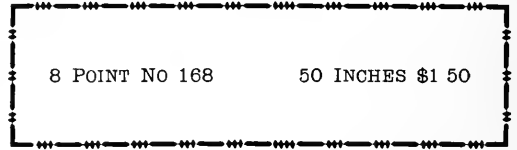

FLORENTINE BORDERS

8 POINT NO 277 50 INCHES \$1 50



8 POINT NO 160 50 INCHES \$1 50



12 POINT NO 159 36 INCHES \$1 50



16 POINT NO 158 30 INCHES \$1 50



18 POINT NO 233 30 INCHES \$1 50



24 POINT NO 234 20 INCHES \$1 50



14 POINT NO 231 30 INCHES \$1 50



18 POINT NO 232 30 INCHES \$1 50



18 POINT NO 235 30 INCHES \$1 50



12 POINT NO 146 36 INCHES \$1 50



18 POINT NO 145 30 INCHES \$1 50



24 POINT NO 144 20 INCHES \$1 50



6 POINT NO 276 54 INCHES \$1 50



10 POINT NO 157 40 INCHES \$1 50



12 POINT NO 153 36 INCHES \$1 50



16 POINT NO 150 30 INCHES \$1 50



18 POINT NO 230 30 INCHES \$1 50



18 POINT NO 229 30 INCHES \$1 50



12 POINT NO 143 36 INCHES \$1 50



18 POINT NO 142 30 INCHES \$1 50



24 POINT NO 141 20 INCHES \$1 50



12 POINT NO 140 36 INCHES \$1 50



18 POINT NO 139 30 INCHES \$1 50



24 POINT NO 138 20 INCHES \$1 50



ELZEVIR BORDERS, BANDS AND ORNAMENTS

6 POINT NO 100 54 INCHES \$1 50



14 POINT NO 104 36 INCHES \$1 50



14 POINT NO 106 36 INCHES \$1 50



20 POINT NO 108 30 INCHES \$1 50



28 POINT NO 112 18 INCHES \$1 50



28 POINT NO 113 18 INCHES \$1 50



28 POINT NO 122 18 INCHES \$1 50



28 POINT NO 116 18 INCHES \$1 50



28 POINT NO 117 18 INCHES \$1 50



28 POINT NO 118 18 INCHES \$1 50



7 POINT NO 101 54 INCHES \$1 50



14 POINT NO 105 36 INCHES \$1 50



14 POINT NO 107 36 INCHES \$1 50



20 POINT NO 109 30 INCHES \$1 50



20 POINT NO 110 30 INCHES \$1 50



28 POINT NO 114 18 INCHES \$1 50



28 POINT NO 123 18 INCHES \$1 50



ELZEVIR BORDERS, BANDS AND ORNAMENTS

48 POINT NO 127



15 CENTS EACH

14 POINT NO 102



14 POINT NO 103



36 INCHES \$1 50

36 INCHES \$1 50

48 POINT NO 126

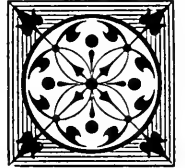

15 CENTS EACH

24 POINT NO 115



20 INCHES \$1 50

28 POINT NO 119



18 INCHES \$1 50

28 POINT NO 120



18 INCHES \$1 50

28 POINT NO 121



18 INCHES \$1 50

36 POINT NO 111



18 INCHES \$1 50

42 POINT NO 124



12 INCHES \$1 50

42 POINT NO 125



12 INCHES \$1 50

BARTA BORDERS

72 POINT NO 294

24 INCHES \$3 00

48 POINT NO 283

12 INCHES \$1 50



14 POINT NO 245

36 INCHES \$1 50



54 POINT NO 293

24 INCHES \$3 00

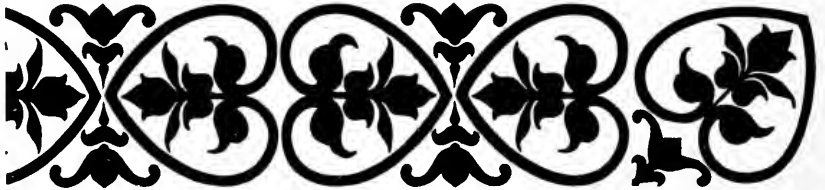

36 POINT NO 254

18 INCHES \$1 50

12 POINT NO 285

36 INCHES \$1 50

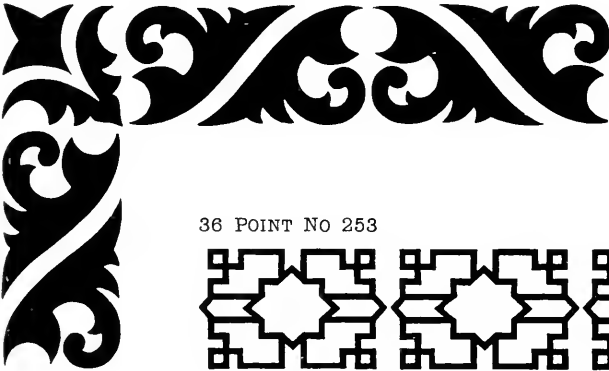

36 POINT NO 253

18 INCHES \$1 50

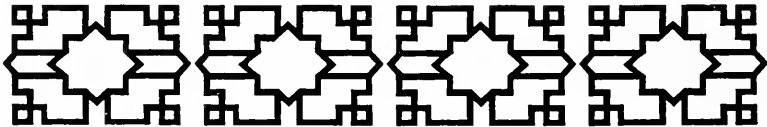

12 POINT NO 286

36 INCHES \$1 50



36 POINT NO 255
18 INCHES \$1 50

36 POINT NO 252 18 INCHES \$1 50

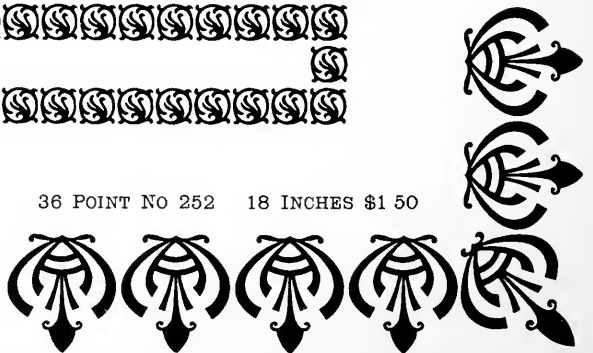

BARTA BORDERS

30 POINT NO 243

20 INCHES \$1 50

30 POINT NO 251

20 INCHES \$1 50



24 POINT NO 289

20 INCHES \$1 50



18 POINT NO 250

30 INCHES \$1 50

18 POINT NO 249

30 INCHES \$1 50

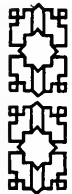
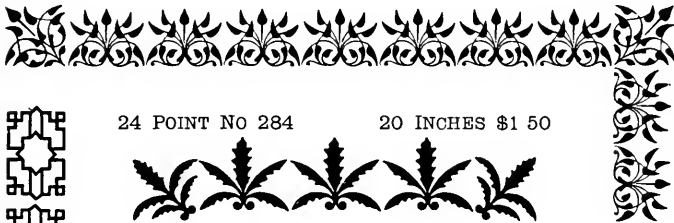

24 POINT NO 284

20 INCHES \$1 50



12 POINT NO 244

36 INCHES \$1 50



18 POINT NO 291

30 INCHES \$1 50



8 POINT NO 290

50 INCHES \$1 50



24 POINT NO 242

20 INCHES \$1 50



24 POINT NO 281

20 INCHES \$1 50



18 POINT NO 248

30 INCHES \$1 50



18 POINT NO 247

30 INCHES \$1 50



18 POINT NO 241

30 INCHES \$1 50



18 POINT NO 246

30 INCHES \$1 50



12 POINT NO 292

36 INCHES \$1 50



12 POINT NO 282

36 INCHES \$1 50



36 POINT NO 287 18 INCHES \$1 50



36 POINT NO 288 18 INCHES \$1 50



CONTOUR BANDS AND BORDERS

Patent applied for

24 POINT NO 260

20 INCHES \$1 50

24 POINT NO 259

20 INCHES \$1 50



24 POINT NO 266

20 INCHES \$1 50



42 POINT NO 296

12 INCHES \$1 50

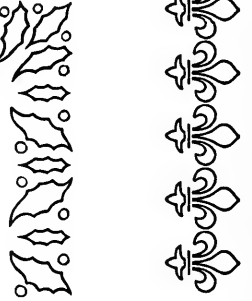

18 POINT NO 275

30 INCHES \$1 50

12 POINT NO 274

36 INCHES \$1 50



6 POINT NO 272

54 INCHES \$1 50

10 POINT NO 273

40 INCHES \$1 50

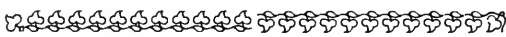

Two styles of corners furnished with Borders Nos. 272, 273, 274 and 275

18 POINT NO 258

30 INCHES \$1 50

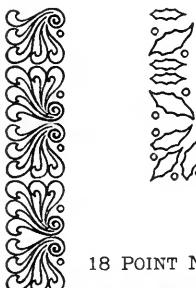

18 POINT NO 265

30 INCHES \$1 50



18 POINT NO 269 30 INCHES \$1 50



24 POINT NO 268

20 INCHES \$1 50

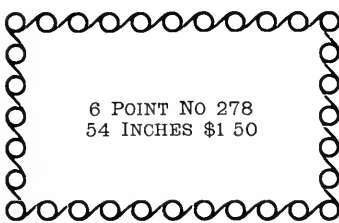

6 POINT NO 278
54 INCHES \$1 50

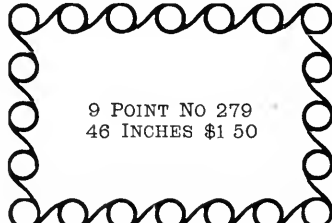

9 POINT NO 279
46 INCHES \$1 50

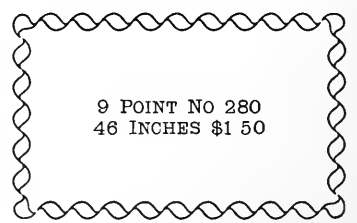

9 POINT NO 280
46 INCHES \$1 50

Several of these Bands and Borders are shown in two colors on pages 753 and 754

CONTOUR BANDS AND BORDERS

36 POINT NO 262

18 INCHES \$1 50



36 POINT NO 298

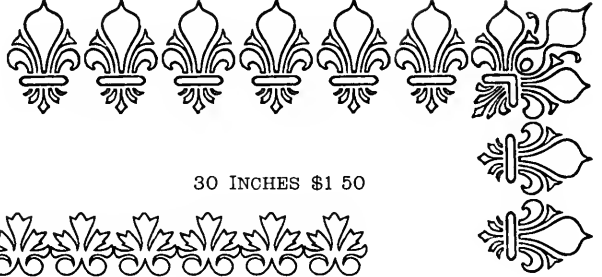

18 INCHES \$1 50

18 POINT NO 257

30 INCHES \$1 50

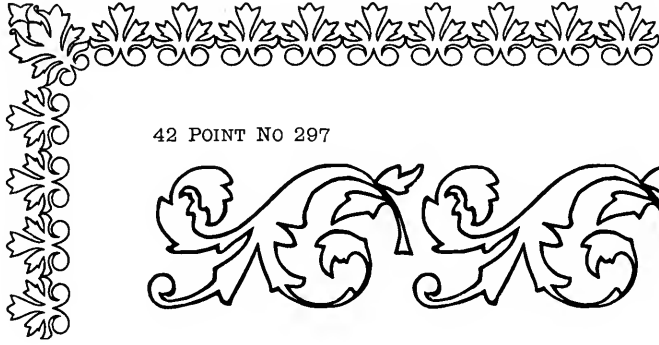

42 POINT NO 297

12 INCHES \$1 50



16 POINT NO 267

30 INCHES \$1 50

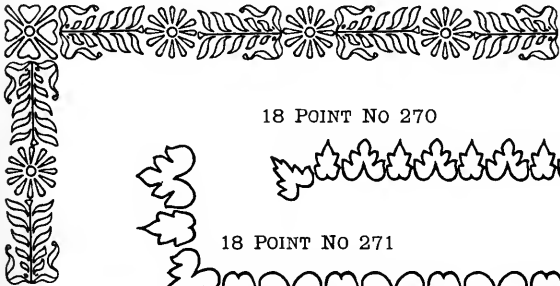

16 POINT NO 264

30 INCHES \$1 50

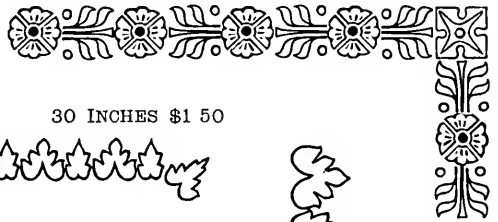

18 POINT NO 270

30 INCHES \$1 50

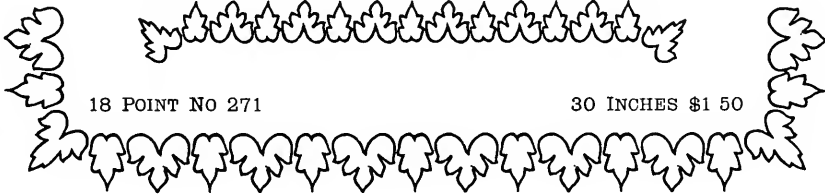

18 POINT NO 271

30 INCHES \$1 50



48 POINT NO 295

12 INCHES \$1 50

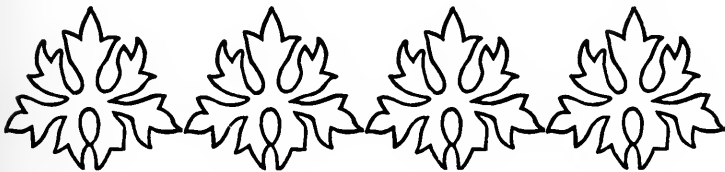

18 POINT NO 261

30 INCHES \$1 50



30 POINT NO 263

20 INCHES \$1 50



Several of these Bands and Borders are shown in two colors on pages 753, 754 and 756

LAUREL BORDERS

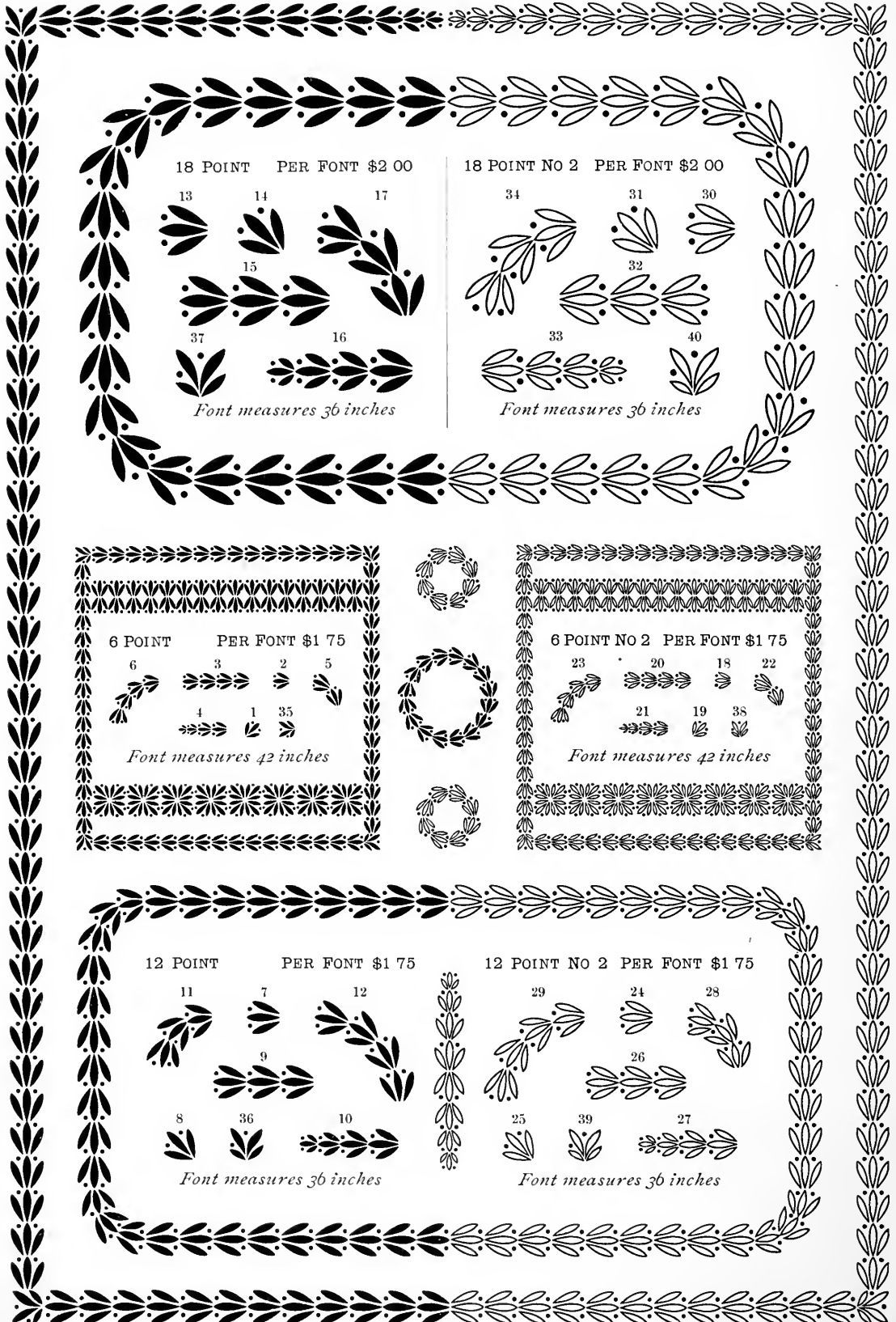

18 POINT PER FONT \$2 00

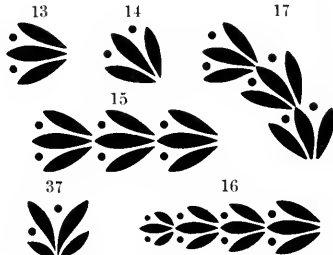

Font measures 36 inches

18 POINT NO 2 PER FONT \$2 00

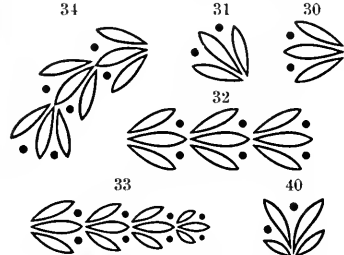

Font measures 36 inches

6 POINT PER FONT \$1 75

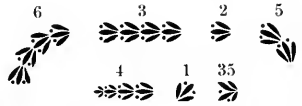

Font measures 42 inches

6 POINT NO 2 PER FONT \$1 75

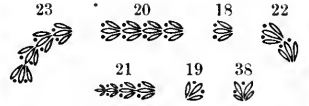

Font measures 42 inches

12 POINT PER FONT \$1 75

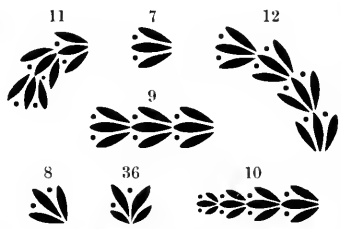

Font measures 36 inches

12 POINT NO 2 PER FONT \$1 75

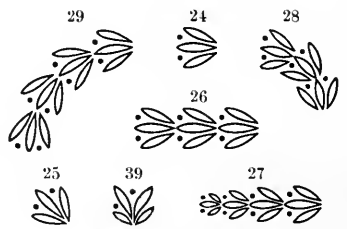

Font measures 36 inches

TWO-COLOR BORDERS

These Borders also shown in one color on pages 740, 741, 744, 745, 750 and 751

18 POINT CONTOUR BORDER NO. 261

18 POINT COLLINS BORDER NO. 173



EACH, 30 INCHES, \$1 50

24 POINT CONTOUR BORDER NO. 259

24 POINT COLLINS BORDER NO. 196



EACH, 20 INCHES, \$1 50

24 POINT CONTOUR BORDER NO. 266

24 POINT FLORENTINE BORDER NO. 234



EACH, 20 INCHES, \$1 50

24 POINT CONTOUR BORDER NO. 268

24 POINT FLORENTINE BORDER NO. 162



EACH, 20 INCHES, \$1 50

42 POINT CONTOUR BAND NO. 296

42 POINT COLLINS BAND NO. 193



EACH, 12 INCHES, \$1 50

42 POINT CONTOUR BAND NO. 297

42 POINT COLLINS BAND NO. 204

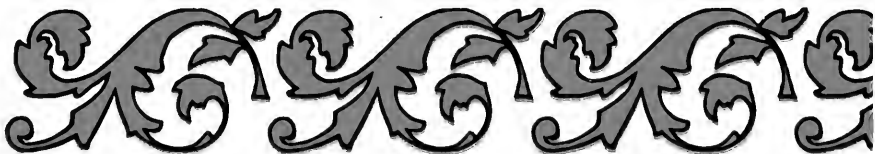

EACH, 12 INCHES, \$1 50

RED, WHITE AND BLUE BORDER

18 POINT 42 INCHES EACH
COLOR. \$5 30



18 POINT CONTOUR BORDER NO. 257
18 POINT COLLINS BORDER NO. 198



EACH, 30 INCHES, \$1 50

18 POINT CONTOUR BAND NO. 258
18 POINT COLLINS BAND NO. 221



EACH, 30 INCHES, \$1 50



18 POINT CONTOUR BORDER NO. 275
18 POINT CAXTON BORDER NO. 240



EACH, 30 INCHES, \$1 50

12 POINT CONTOUR BORDER NO. 274
12 POINT CAXTON BORDER NO. 239



EACH 36 INCHES, \$1 50

16 POINT CONTOUR BORDER NO. 267
16 POINT FLORENTINE BORDER NO. 158

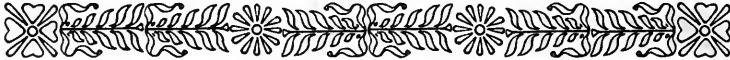

EACH, 30 INCHES, \$1 50

24 POINT COLLINS BAND NO. 217
24 POINT COLLINS BAND NO. 211



EACH, 20 INCHES, \$1 50

UNION BORDER

18 POINT, 42 INCHES, \$2 65

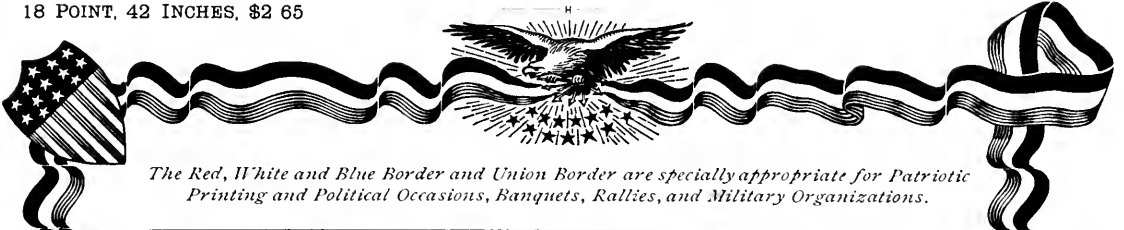

The Red, White and Blue Border and Union Border are specially appropriate for Patriotic Printing and Political Occasions, Banquets, Rallies, and Military Organizations.

44 POINT AMERICAN FLAGS FOR TWO COLORS
\$2 50 PER HALF DOZEN OF EACH COLOR

ELZEVIR FLORETS

| | | |
|---------|--|---------|
| GROUP C | | GROUP D |
| | | |

PER FONT EACH \$2 00

For other sizes of Elzevir Florets, for one color, see page 779

36 POINT FLAG BORDER NO. 2, FOR TWO COLORS, 18 INCHES, \$4 50

For other sizes of Flag Border, shown in one color, see page 760

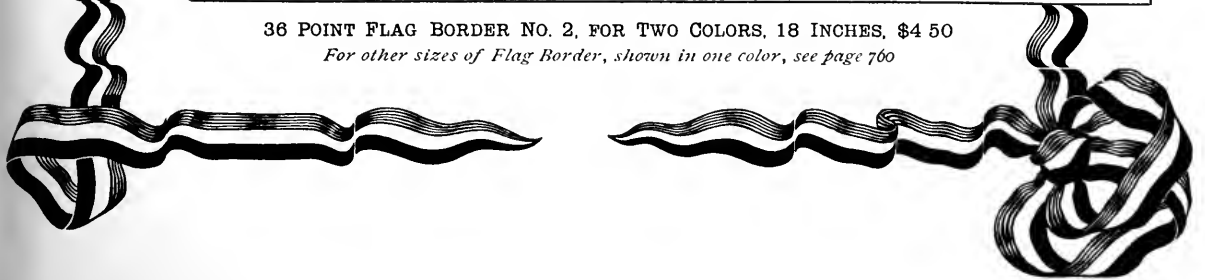

TWO-COLOR BORDERS

These Borders also shown in one color on pages 727-730 and 751

18 POINT FLORENTINE BORDER NO. 229

18 POINT CONTOUR BORDER NO. 270



EACH, 30 INCHES, \$1 50

12 POINT ART BORDER NO. 5, TINT

12 POINT ART BORDER NO. 5, OPEN



EACH, 60 INCHES, \$1 60

18 POINT ART BORDER NO. 7, TINT

18 POINT ART BORDER NO. 7, OPEN



EACH, 60 INCHES, \$2 00

18 POINT ART BORDER NO. 4, TINT

18 POINT ART BORDER NO. 4, OPEN



EACH, 60 INCHES, \$2 00

24 POINT ART BORDER NO. 3, TINT

24 POINT ART BORDER NO. 3, OPEN



EACH, 36 INCHES, \$1 65

24 POINT ART BORDER NO. 7, TINT

24 POINT ART BORDER NO. 6



EACH, 36 INCHES, \$1 65

24 POINT ART BORDER NO. 9

24 POINT ART BORDER NO. 10

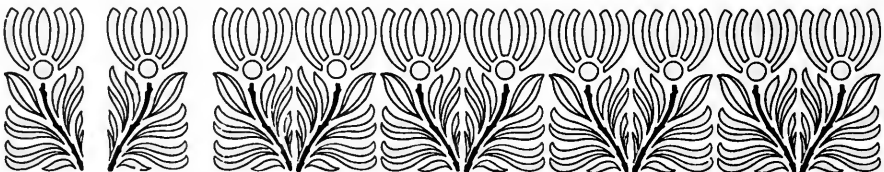

EACH, 36 INCHES, \$1 65

IPSEN BORDERS

24 POINT NO 134

20 INCHES \$1 50



18 POINT NO 131

30 INCHES \$1 50



18 POINT NO 130

30 INCHES \$1 50



18 POINT NO 133

30 INCHES \$1 50



18 POINT NO 132

30 INCHES \$1 50

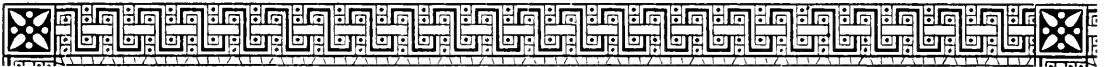

12 POINT NO 135

36 INCHES \$1 50



12 POINT NO 136

36 INCHES \$1 50



12 POINT NO 137

36 INCHES \$1 50



COPTIC BORDERS

36 POINT NO 1

18 INCHES \$1 50

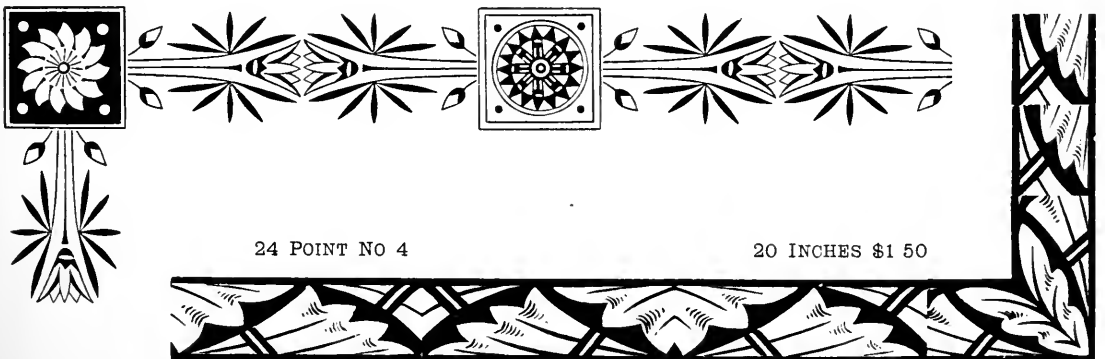

24 POINT NO 4

20 INCHES \$1 50



36 POINT NO 1

24 INCHES \$2 50

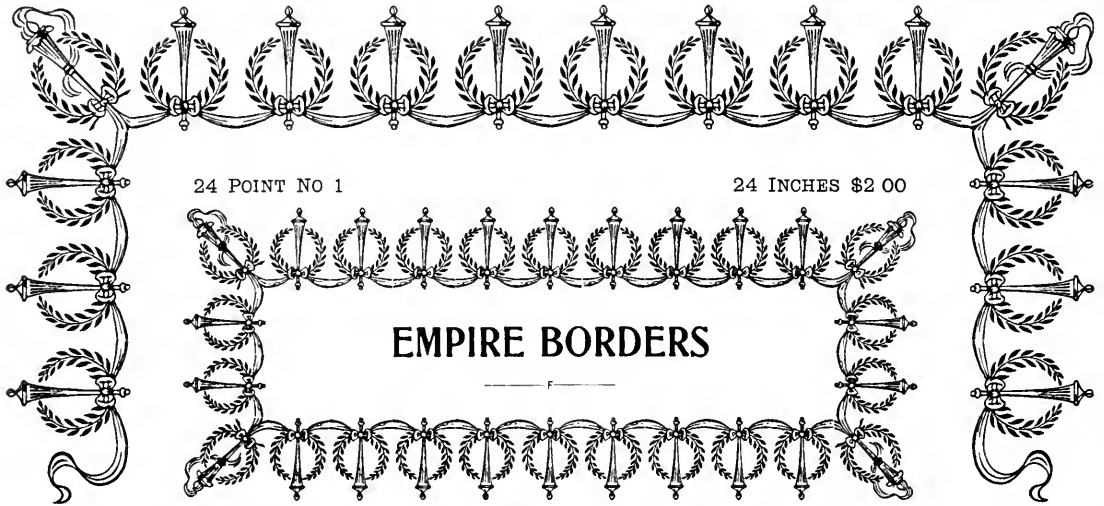

36 POINT NO 2

24 INCHES \$2 50

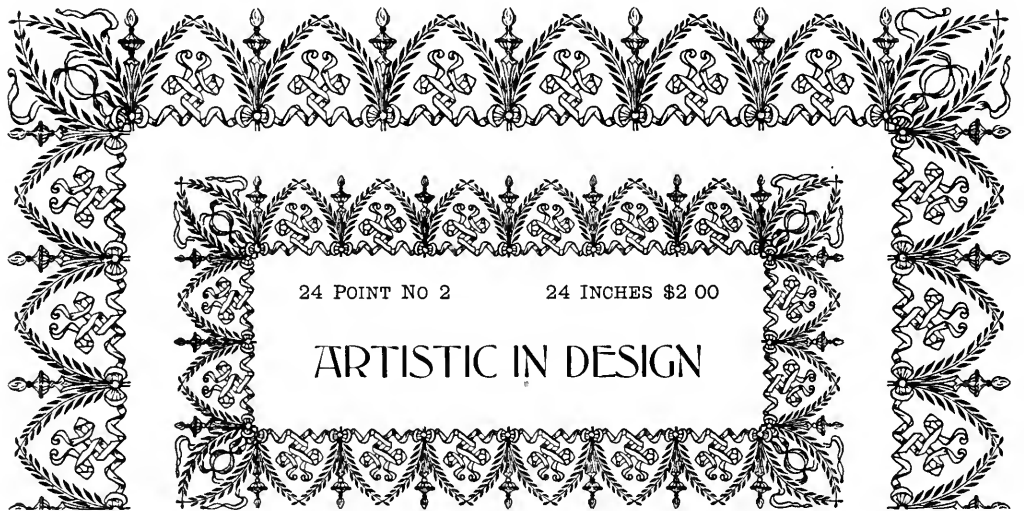

36 POINT NO 3

24 INCHES \$2 50

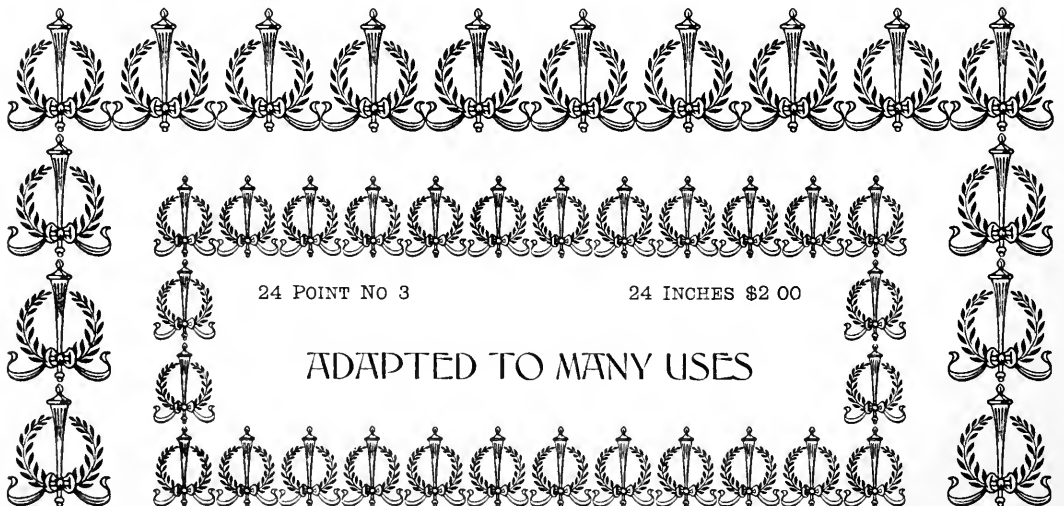

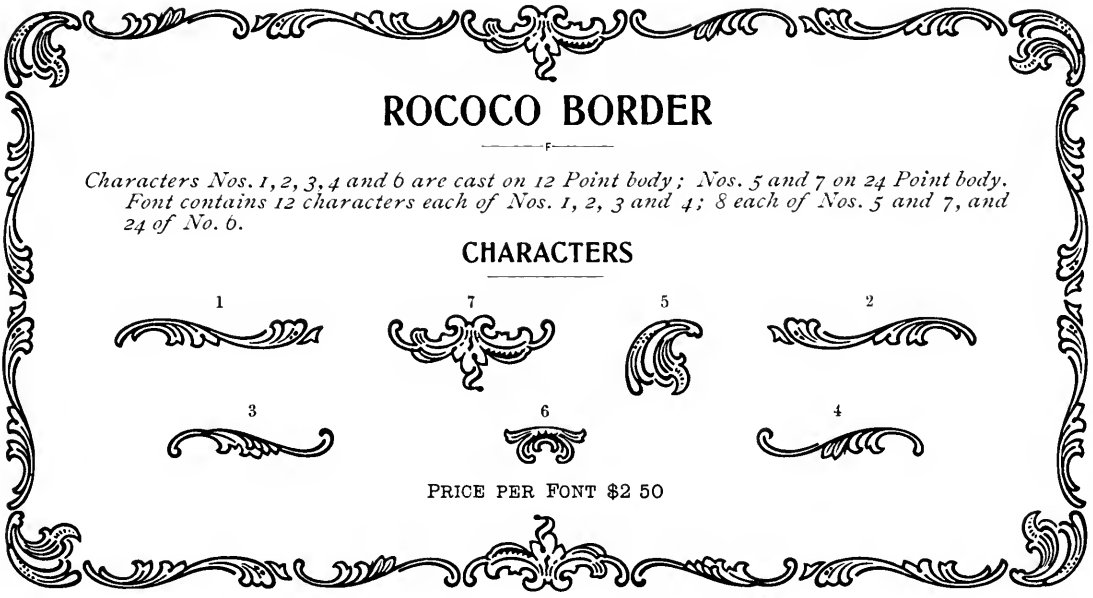

ROCOCO BORDER

*Characters Nos. 1, 2, 3, 4 and 6 are cast on 12 Point body; Nos. 5 and 7 on 24 Point body.
Font contains 12 characters each of Nos. 1, 2, 3 and 4; 8 each of Nos. 5 and 7, and
24 of No. 6.*

CHARACTERS

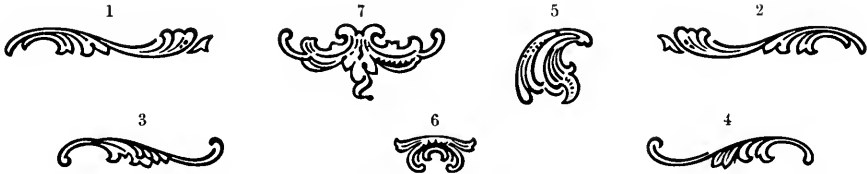

PRICE PER FONT \$2 50

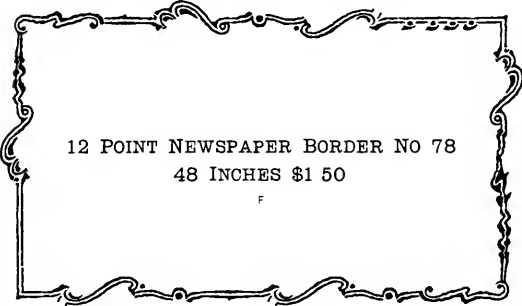

12 POINT NEWSPAPER BORDER NO 78
48 INCHES \$1 50

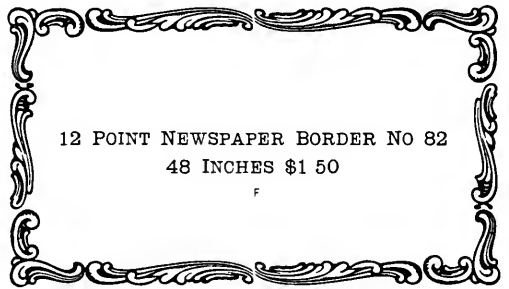

12 POINT NEWSPAPER BORDER NO 82
48 INCHES \$1 50

30 POINT BORDER NO 1

18 INCHES \$1 50

18 POINT BORDER NO 27

24 INCHES \$1 00



PRIMROSE BORDERS

24 POINT 36 INCHES \$2 65

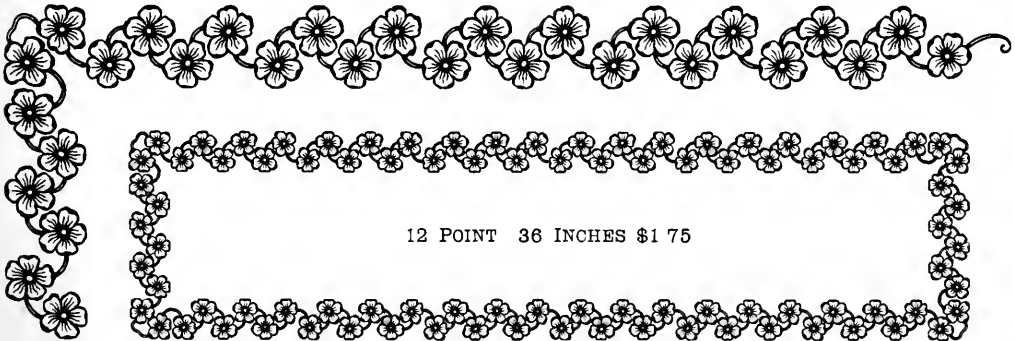

12 POINT 36 INCHES \$1 75

18 POINT 36 INCHES \$2 00



FLAG BORDERS

36 POINT NO 1 FOR ONE COLOR
36 POINT NO 2 FOR TWO COLORS

18 INCHES \$2 25
18 INCHES \$4 50



Shown in two colors on page 755

24 POINT NO 1 FOR ONE COLOR
24 POINT NO 2 FOR TWO COLORS

60 INCHES \$4 40
30 INCHES \$4 40



18 POINT NO 1 FOR ONE COLOR
18 POINT NO 2 FOR TWO COLORS

60 INCHES \$3 35
30 INCHES \$3 35















12 POINT NO 1 FOR ONE COLOR
12 POINT NO 2 FOR TWO COLORS

72 INCHES \$3 50
36 INCHES \$3 50



MYRTLE BORDERS

| | | | |
|---|---|---|---|
| 18 POINT | 36 INCHES | \$2 00 | |
| 1 | 2 | 3 | 4 |
|  |  |  |  |
| | | | 5 |
| | | |  |
| | | | 6 |
| | | |  |
| | | | 12 |
| | | |  |
| | | | 18 |
| | | |  |
| | | | 17 |
| | | |  |
| | | | 16 |
| | | |  |
| | | | 15 |
| | | |  |
| | | | 14 |
| | | |  |
| | | | 13 |
| | | |  |

BRIER BORDER

PER FONT 18 INCHES \$2 00

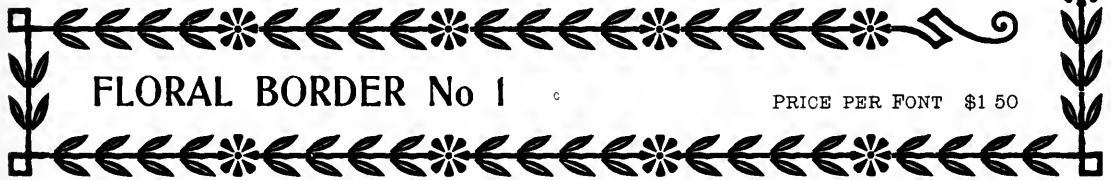
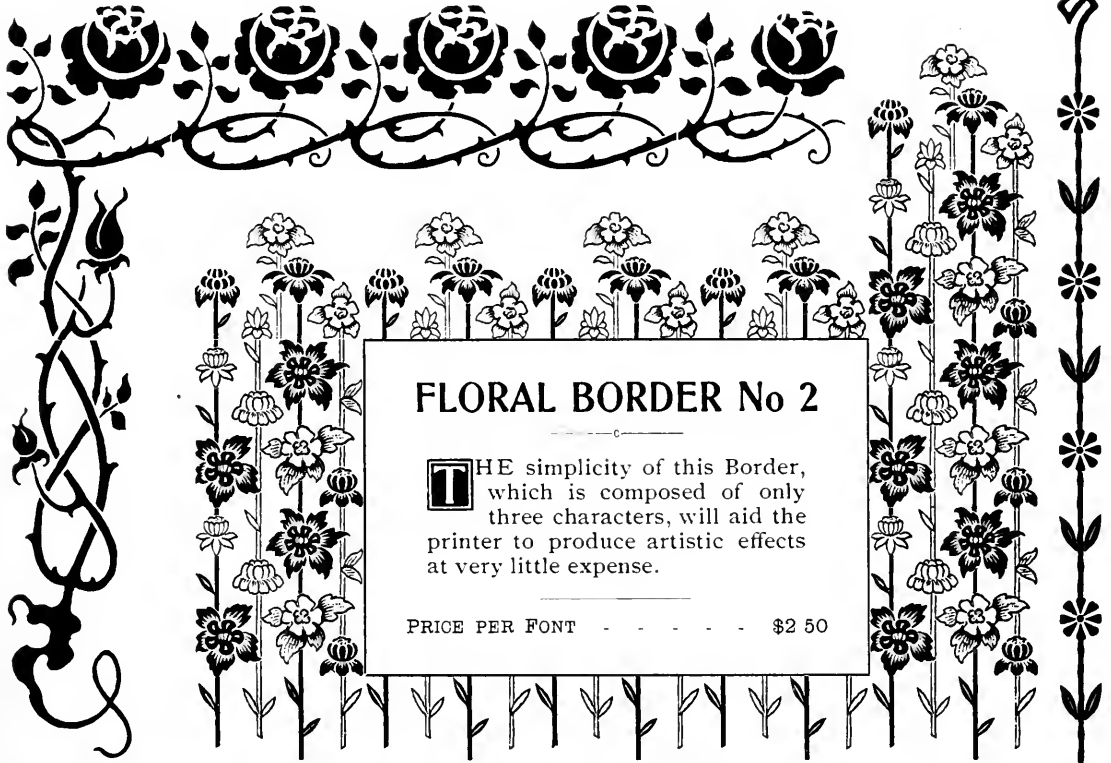

HOLLY BORDER No 1

The Nos. 2 and 3 Borders, when worked in Red and Green respectively, will be found appropriate for many occasions of festivity and for other purposes.



EGYPTIAN ORNAMENTS

THE simplicity of these Ornaments is at once apparent. Artistic effects are quickly produced with the aid of these Ornaments and two-point full-face Brass Rule



SERIES A

PER FONT \$2 50
HALF FONT 1 25

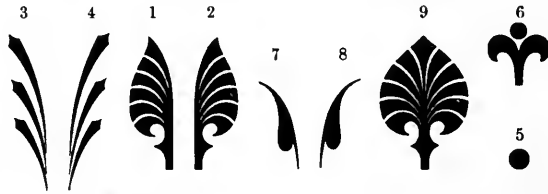

SERIES B

PER FONT \$2 50
HALF FONT 1 25

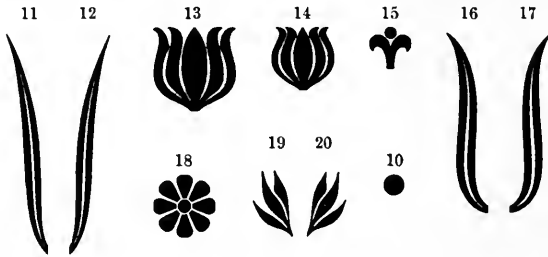

SERIES C

PER FONT \$2 50
HALF FONT 1 25

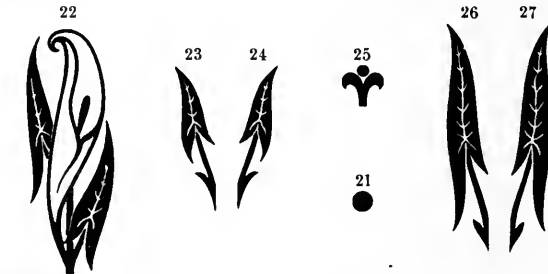

MIDGET TAIL PIECES

PER FONT (containing three of each character) \$1 25



MANILA BORDER

FONT MEASURES 30 INCHES \$1 50



There are seven characters, as above

DEWEY ORNAMENTS

SERIES ONE

FONT (one of each character) \$1 50

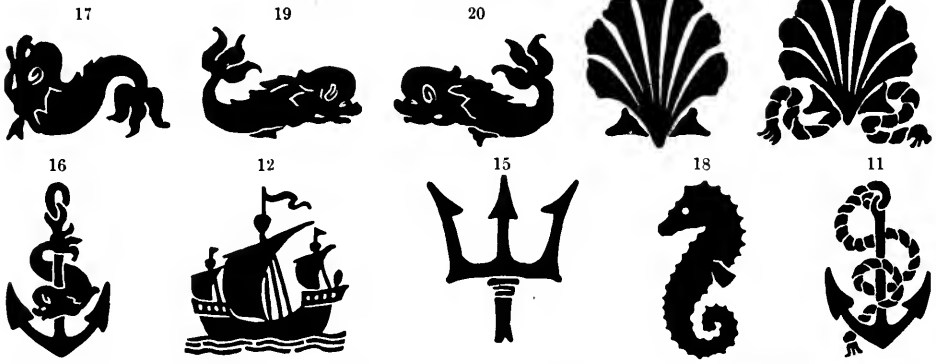

SERIES TWO

FONT (one of each character) \$2 00

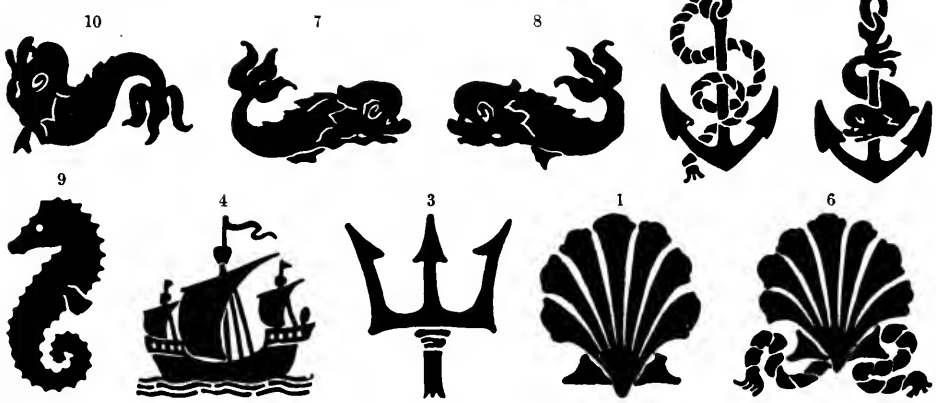

SERIES THREE

FONT (one of each character) \$1 00

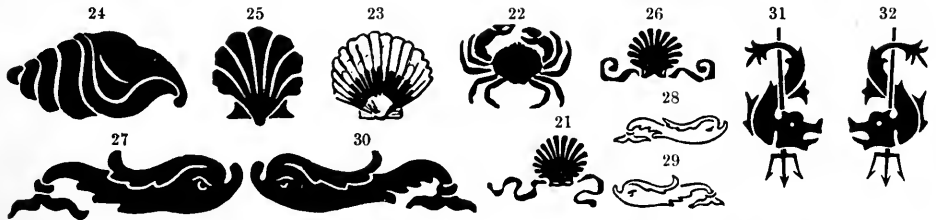

FLAME BORDERS

*Each size is furnished with
Round and Square Corners*

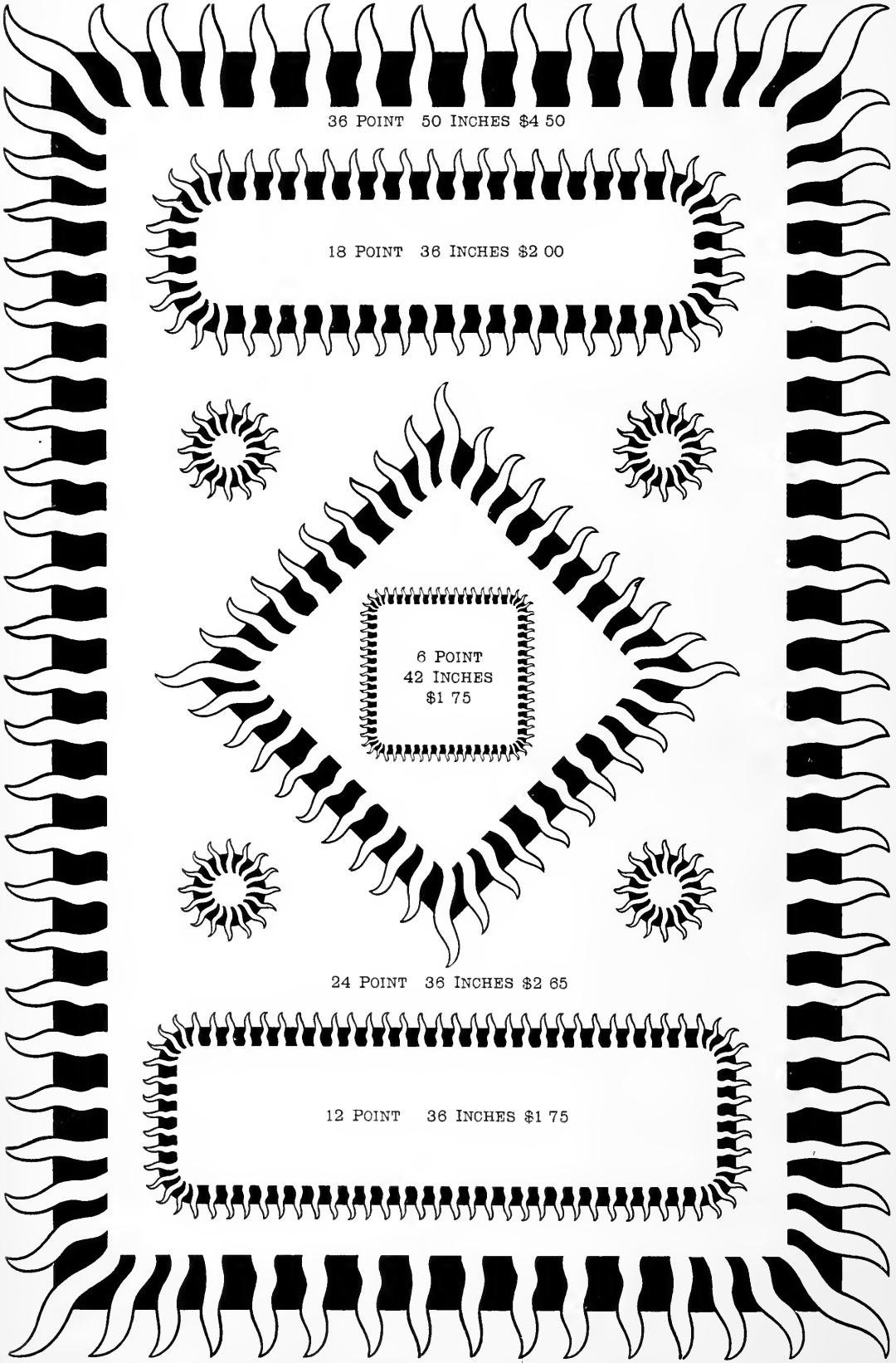

36 POINT 50 INCHES \$4 50



18 POINT 36 INCHES \$2 00

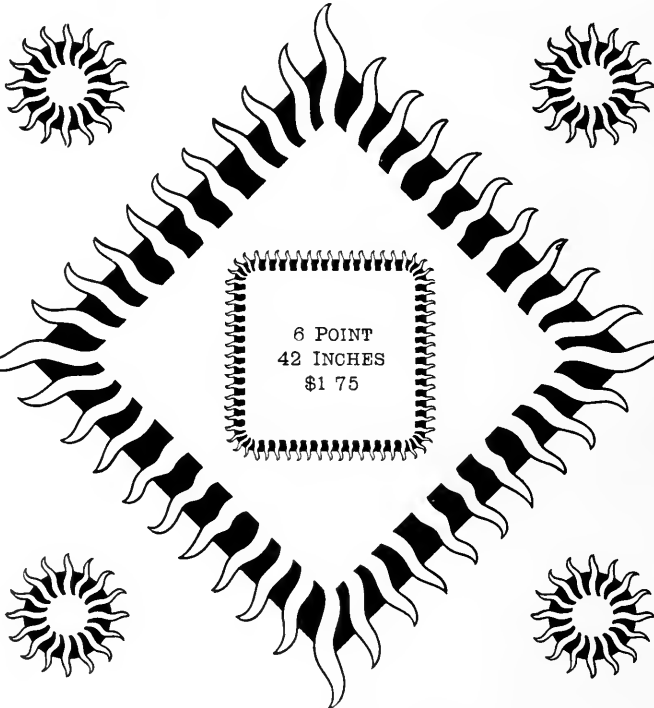

6 POINT
42 INCHES
\$1 75

24 POINT 36 INCHES \$2 65

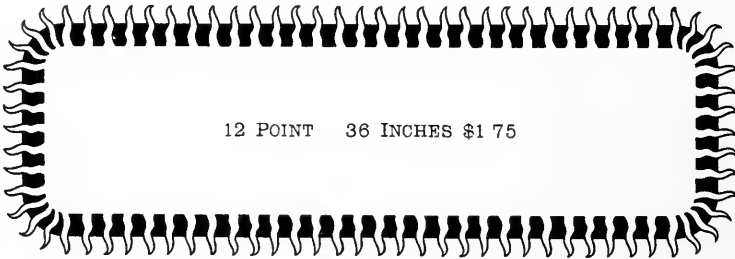

12 POINT 36 INCHES \$1 75

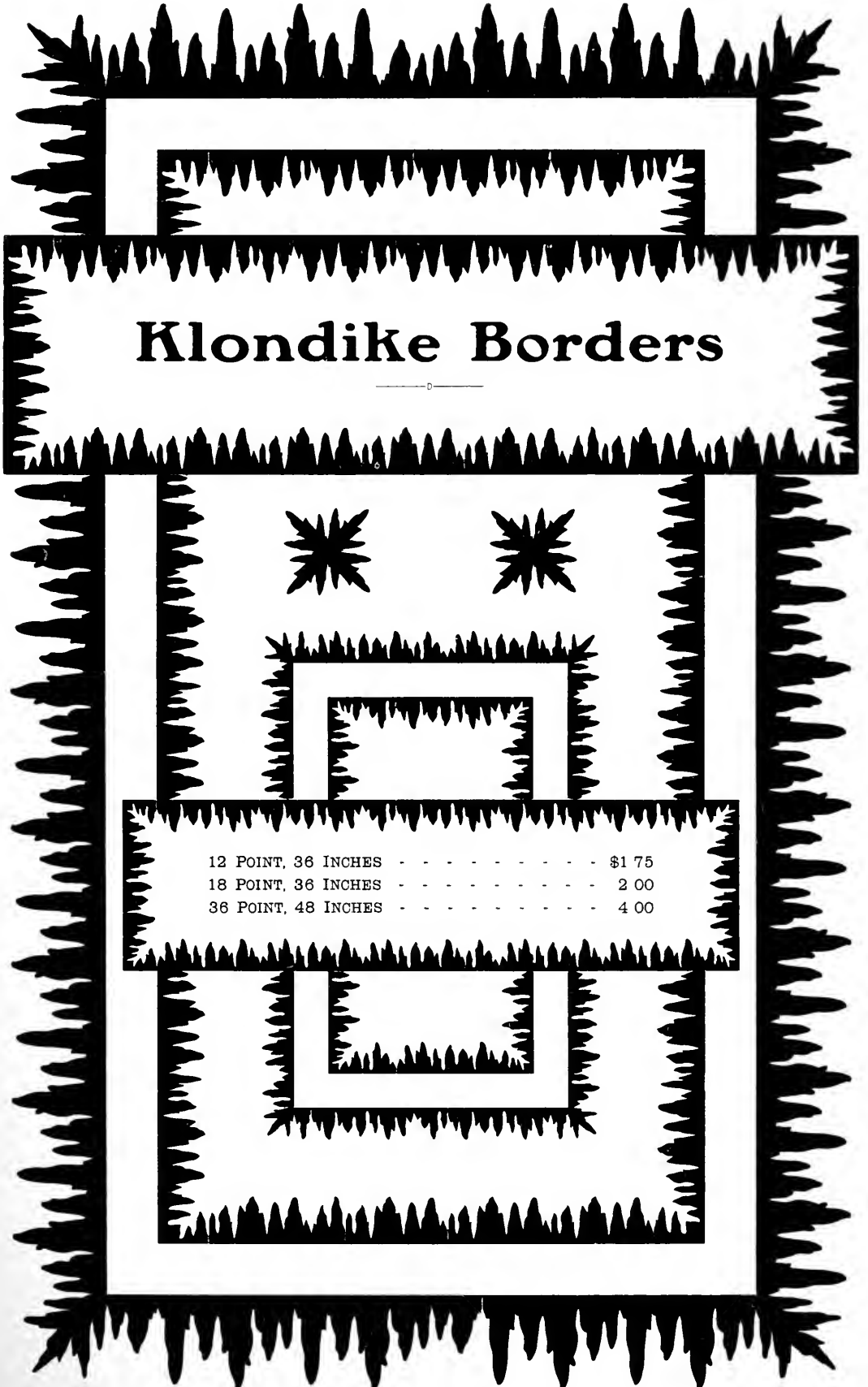

Klondike Borders

| | | |
|---------------------|-----------|--------|
| 12 POINT, 36 INCHES | - - - - - | \$1 75 |
| 18 POINT, 36 INCHES | - - - - - | 2 00 |
| 36 POINT, 48 INCHES | - - - - - | 4 00 |

LAUREL WREATHS

Prices are net

No 8 \$1 00

MORTISED

No 17 \$1 00



No 11 30 Cts.

No 9 \$1 25

No 2 30 CTS



No 10 20 CTS

No 1 20 CTS



No 12 50 CTS

No 3 50 CTS

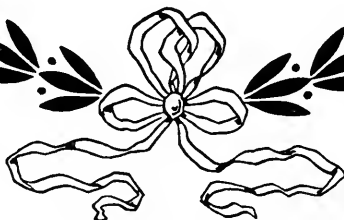

SOLID METAL ELECTROTYPES

LAUREL ORNAMENTS

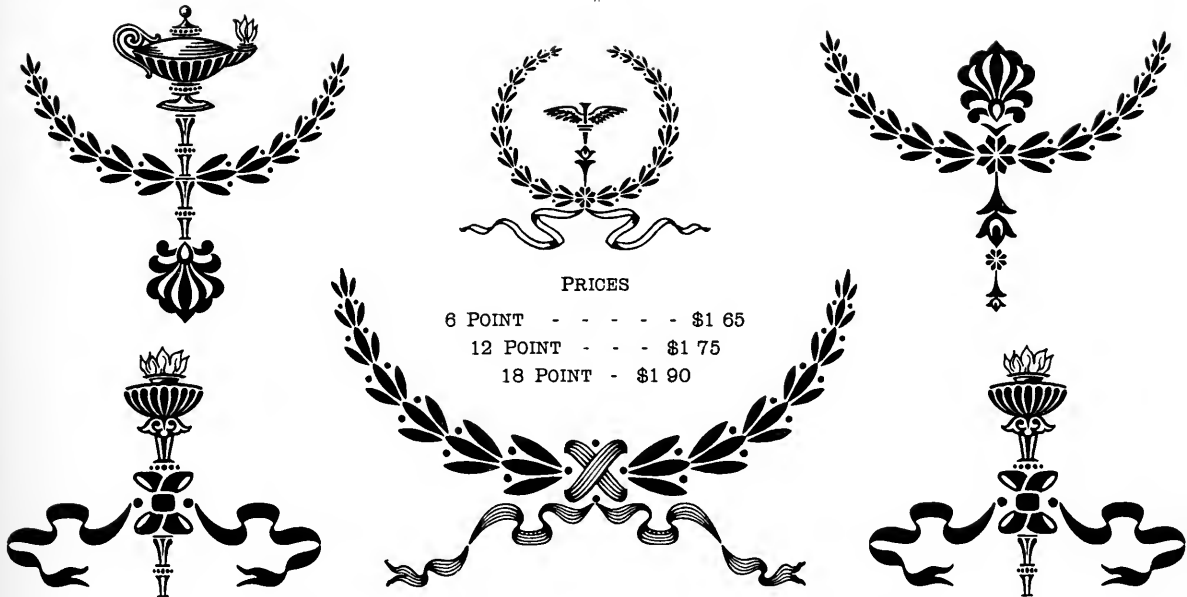

PRICES

6 POINT - - - - - \$1 65
 12 POINT - - - - - \$1 75
 18 POINT - - - - - \$1 90

LAUREL ORNAMENTS

Are designed to work separately and with the Laurel Borders, shown on page 752. Wreaths may be enlarged symmetrical-ly by using the single piece.

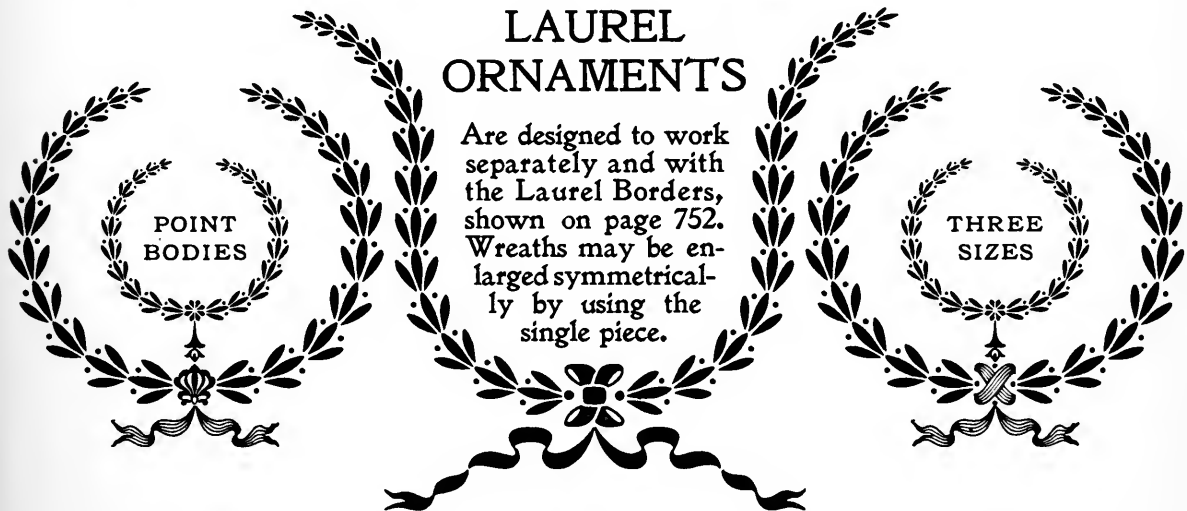

These Ornaments are cast in a cored type mould, with as little shoulder as possible on the inside of the wreaths, so that type lines may be set close up. A great variety of designs may be quickly and easily produced with these inexpensive Ornaments.

CHARACTERS OF 18 POINT LAUREL ORNAMENTS

The characters of 6 Point and 12 Point are nearly alike

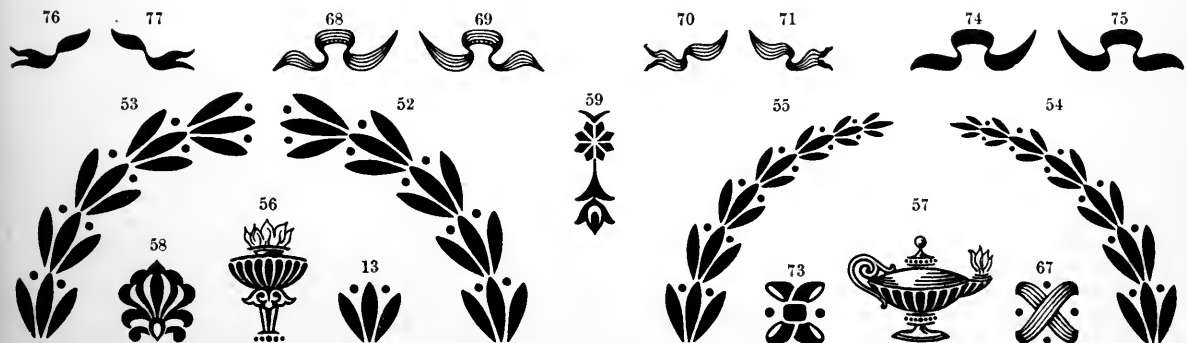

MURAL ORNAMENTS

300.A. 15 cts.



All characters except 292A put up in sets of four at 50 cents per set. Characters Nos. 291.A and 292.A may be used for two-color initials.

295.A. 15 cts.



312.A. 15 cts.



305.A. 15 cts.

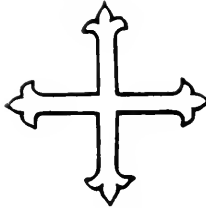

306.A. 15 cts.

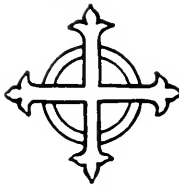

307.A. 15 cts.

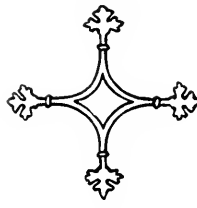

314.A. 15 cts.

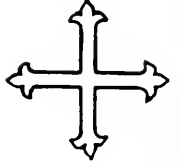

316.A. 15 cts.



315.A. 15 cts.

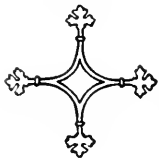

294.A. 15 cts.



290.A. 15 cts.



301.A. 15 cts.



310.A. 15 cts.



293.A. 15 cts.

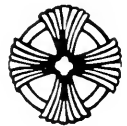

303.A. 15 cts.



302.A. 15 cts.



298.A. 15 cts.



309.A. 15 cts.

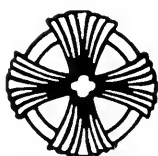

308.A. 15 cts.



311.A. 15 cts.



313.A. 15 cts.



MARGIN ORNAMENTS

SERIES 1

12



14



13



SERIES 2

15



16

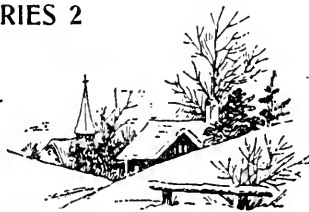

SERIES NO 1 PER FONT \$1 25
SERIES NO 2 PER FONT \$1 00

291.A. 15 cts.



292.A. 30 cts.



304.A. 15 cts.



296.A. 15 cts.



297.A. 15 cts.



CHRISTMAS ORNAMENTS ^A

All characters except 280A put up in sets of four at 50 cents per set

283A. 15 cts. 287A. 15c. 288A. 15c. 286A. 15c. 280A. 40 cts. 281A. 15 cts. 277A. 15 cts. 279A. 15 cts.



282A. 15 cts. 284A. 15 cts. 285A. 15 cts. 276A. 15 cts. 278A. 15 cts.

CLASSIC ORNAMENTS ^B

PER FONT \$6 25

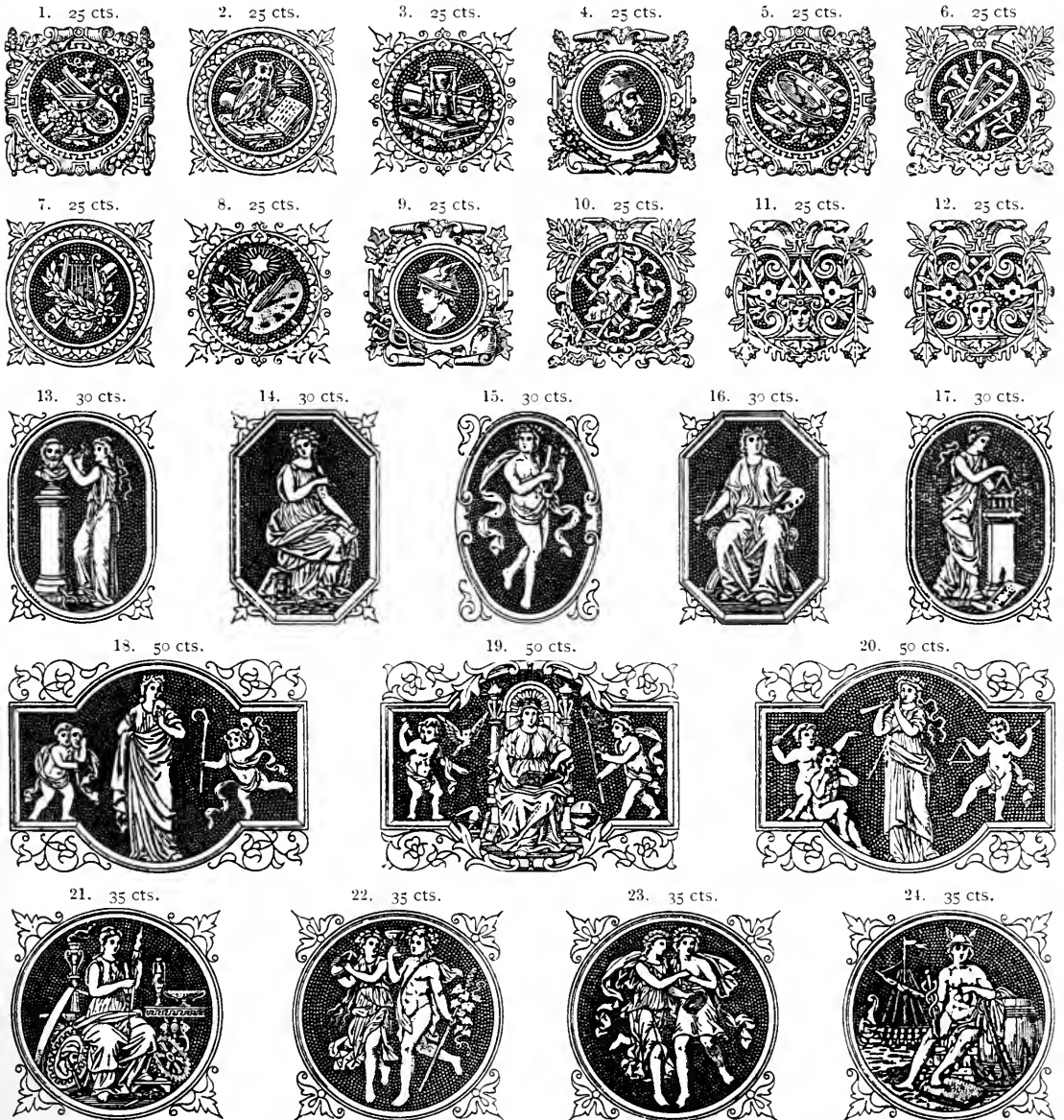

All Ornaments on this page are cast in a type mould

BARTH GEOMETRICAL BORDERS

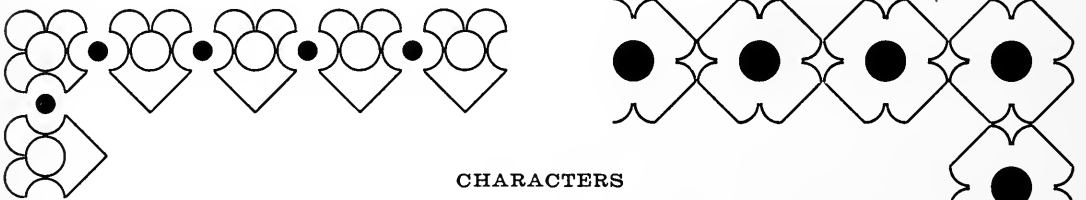
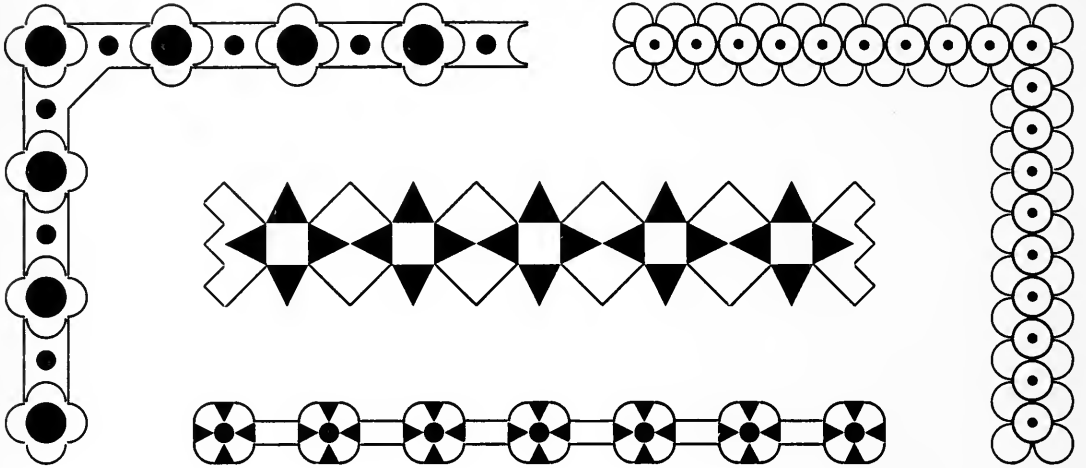

CHARACTERS

| | | | | | | | | | | | |
|------------|-----------|-----------|-----------|-----------|-----------|-----------|------------|-----------|-----------|-----------|-----------|
| 1 | 2 | 3 | 4 | 5 | 6 | 7 | 8 | 9 | 10 | 11 | 12 |
| | | | | | | | | | | | |
| <i>112</i> | <i>54</i> | <i>45</i> | <i>45</i> | <i>27</i> | <i>27</i> | <i>27</i> | <i>110</i> | <i>72</i> | <i>36</i> | <i>72</i> | <i>72</i> |

Figures in Italic denote number of characters in a font

PER FONT \$3 00

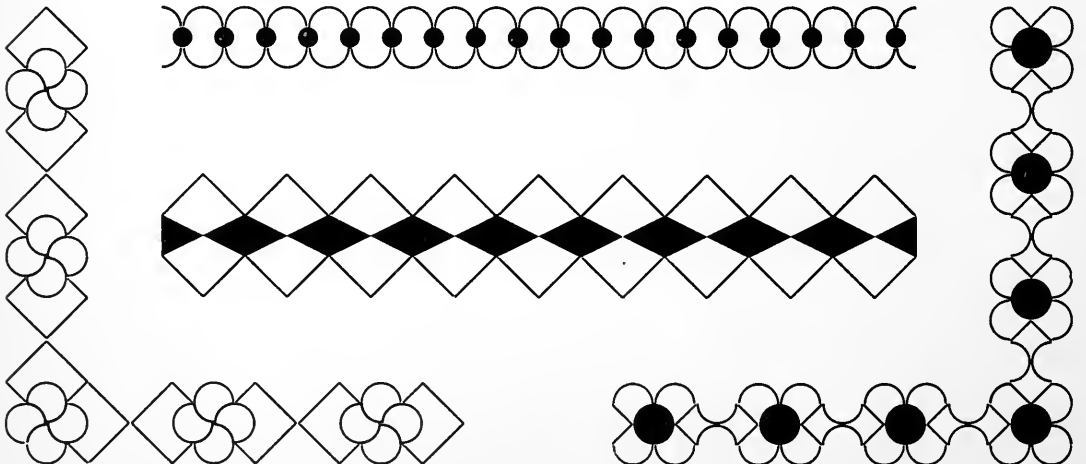
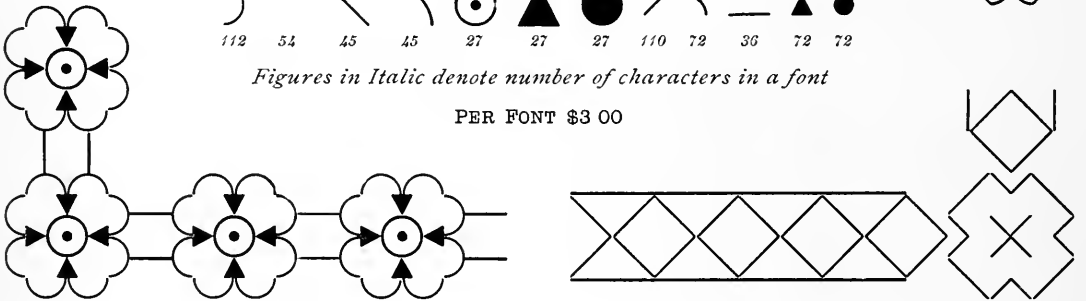

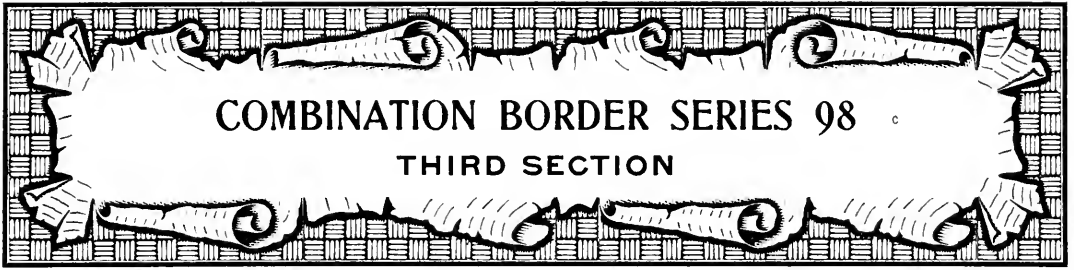

COMBINATION BORDER SERIES 98
THIRD SECTION

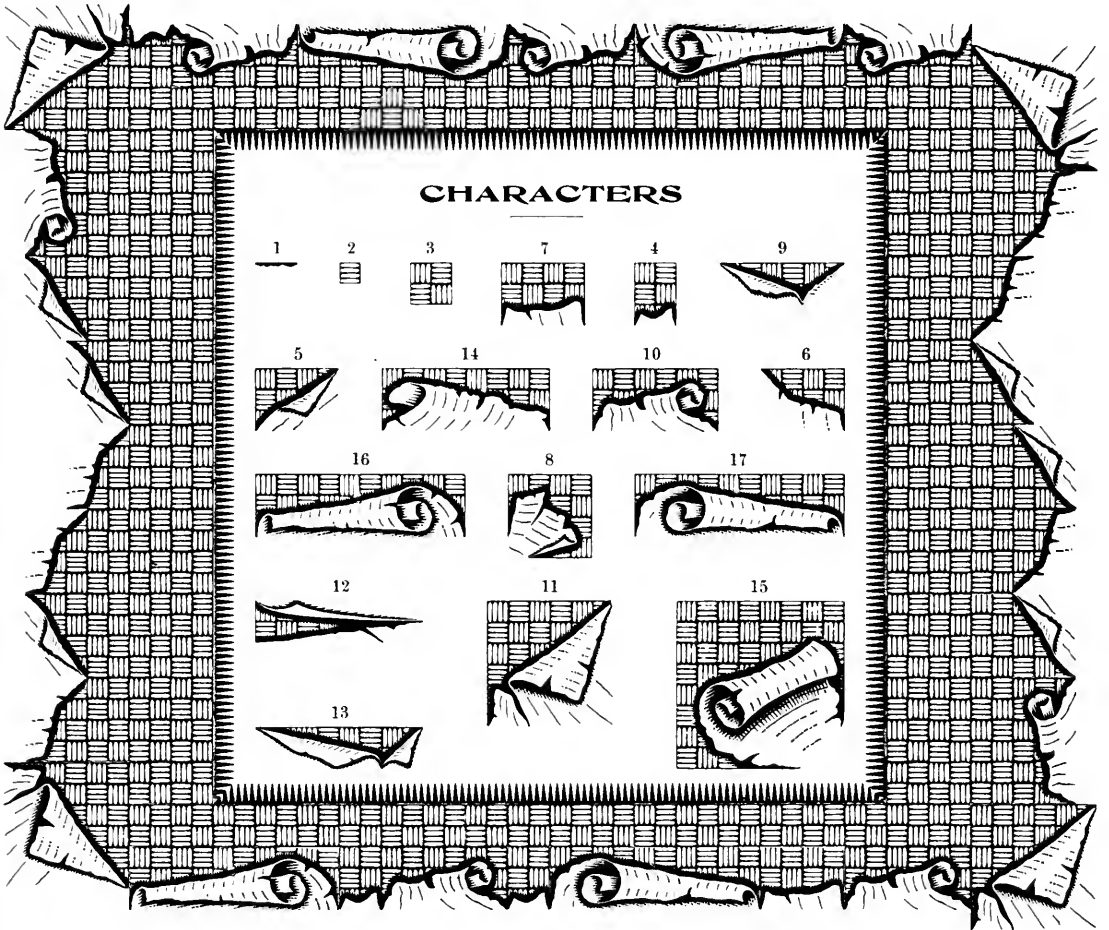

CHARACTERS

- 1
- 2
- 3
- 7
- 4
- 9
- 5
- 14
- 10
- 6
- 16
- 8
- 17
- 12
- 11
- 15
- 13

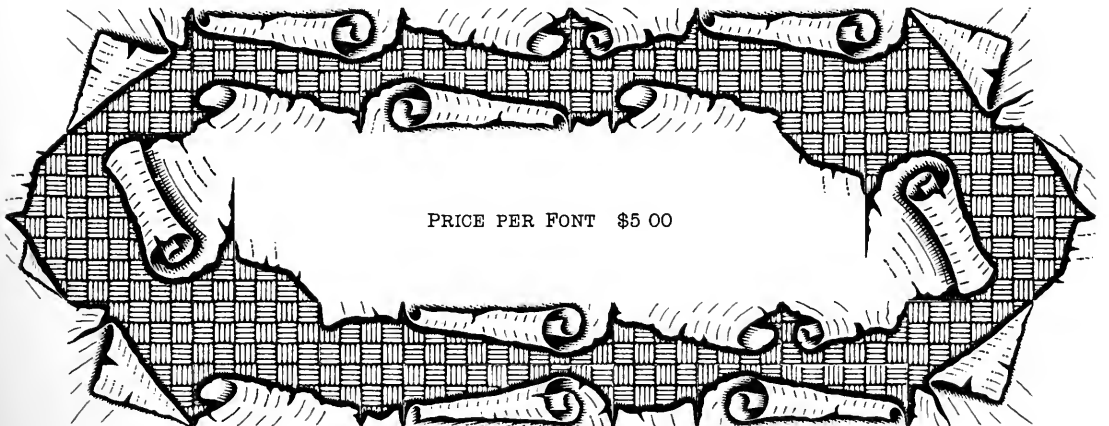

PRICE PER FONT \$5 00

CONTOUR POINTERS ^E

PER FONT \$1 25

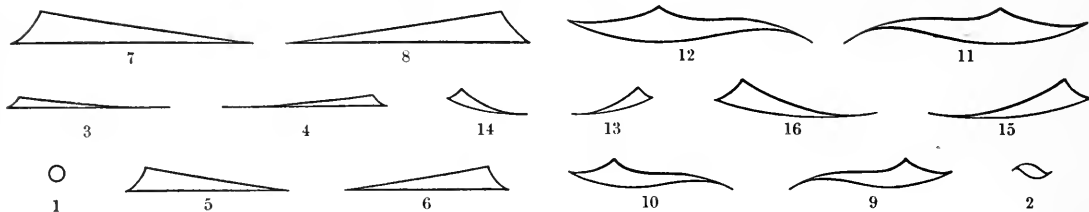

SHADED POINTERS ^E

PER FONT \$1 25

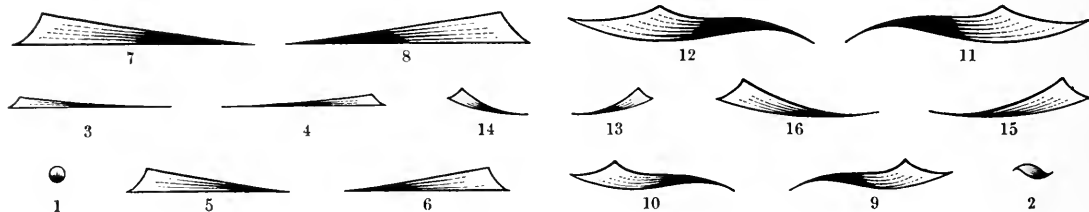

POINTERS ^E

PER FONT \$1 25

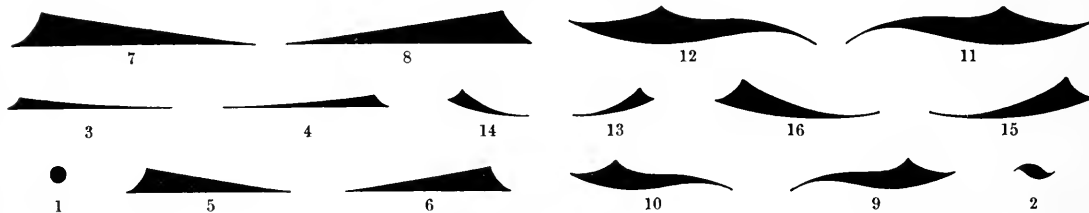

PIN, NAIL AND SCREW HEADS No 2 ^D

PER FONT \$3 00

Fonts contain twelve pieces of each character

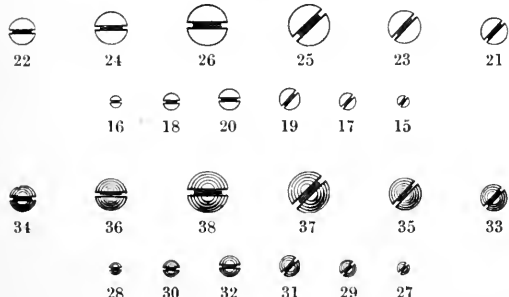
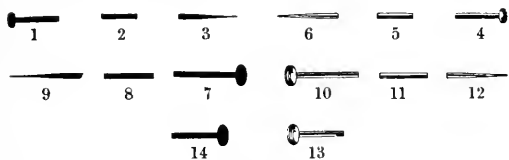

PIN, NAIL AND SCREW HEADS

PER FONT 75 CENTS

Fonts contain twelve of each character

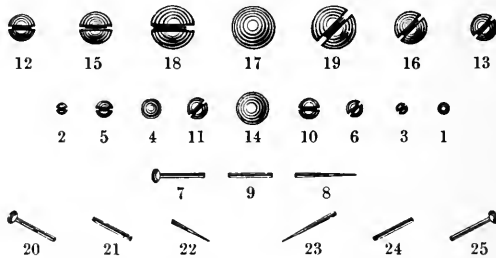

PRINTERS' NIC NACS ^E

All on 6 Point body

PER FONT \$1 00

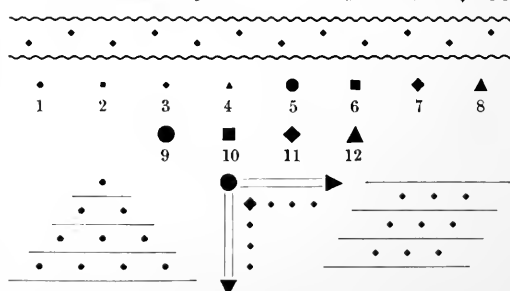

PALMETTO ORNAMENTS

PER FONT \$1 00

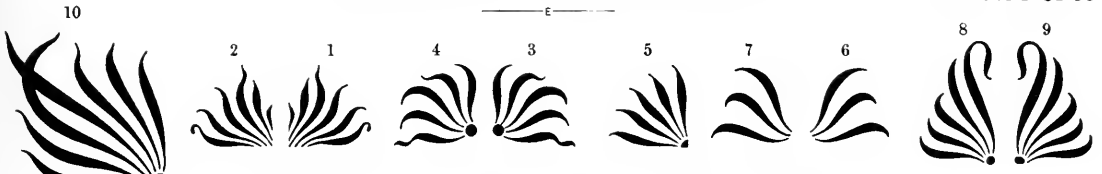

SHADED PALMETTO ORNAMENTS

PER FONT \$1 00

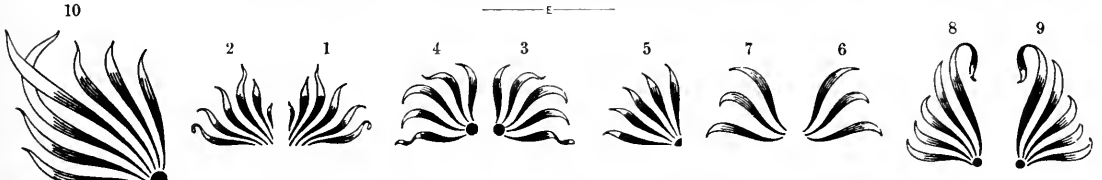

CONTOUR PALMETTO ORNAMENTS

PER FONT \$1 00

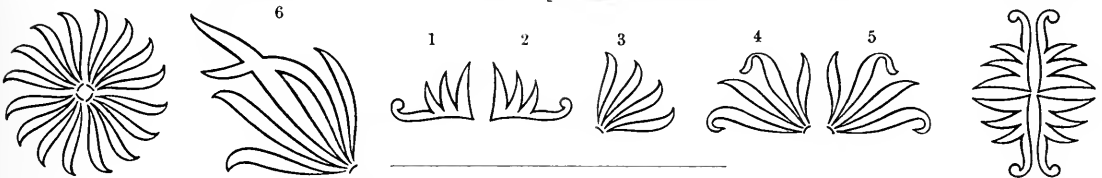

CENTRAL ORNAMENTS No 1

PER FONT \$1 00

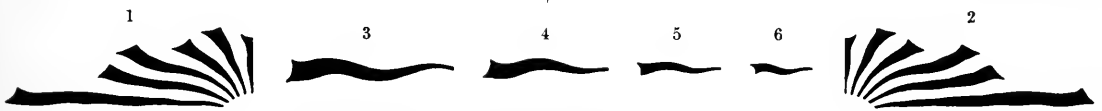

CENTRAL ORNAMENTS No 2

PER FONT \$1 00

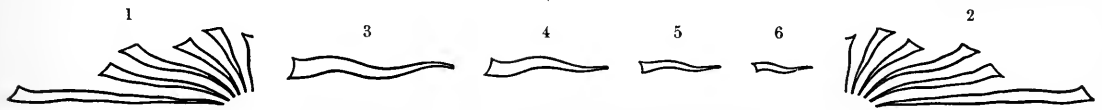

CENTRAL ORNAMENTS No 3

PER FONT \$1 00



TURNER ORNAMENTS

PER FONT \$2 00

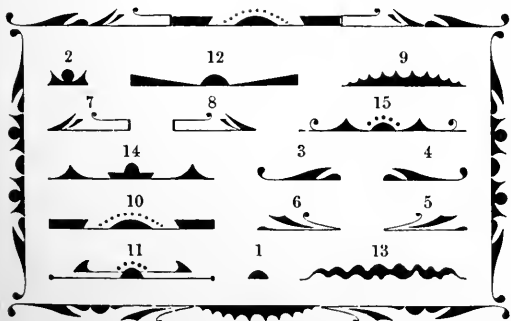

STELLAR ORNAMENTS

PER FONT \$1 25

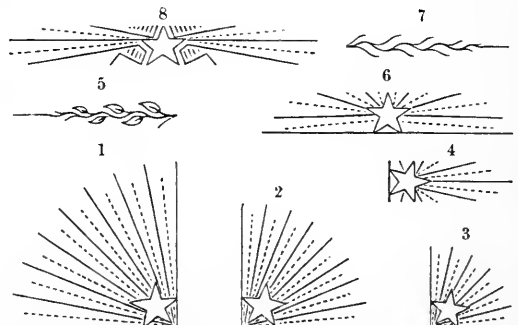

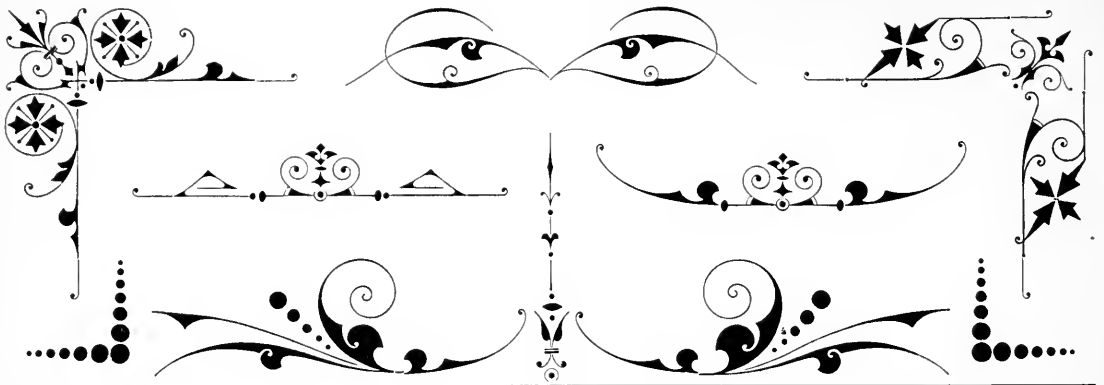

COMBINATION ORNAMENTS SERIES K

PRICE PER FONT \$4 50

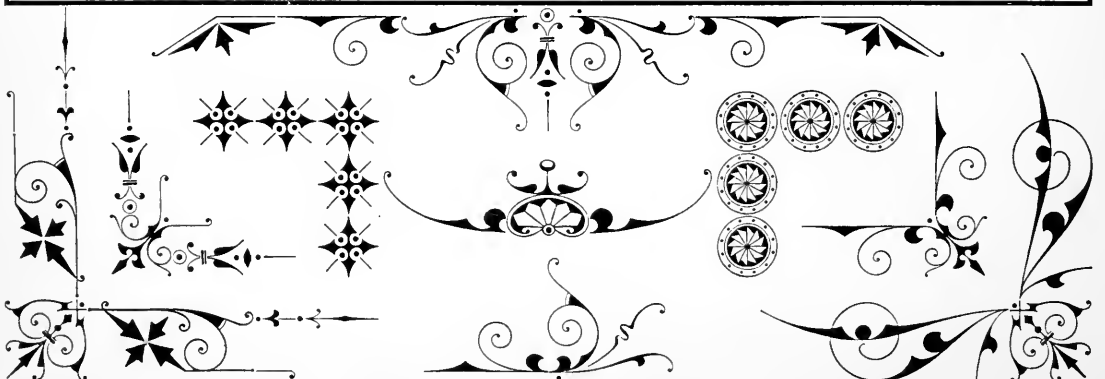
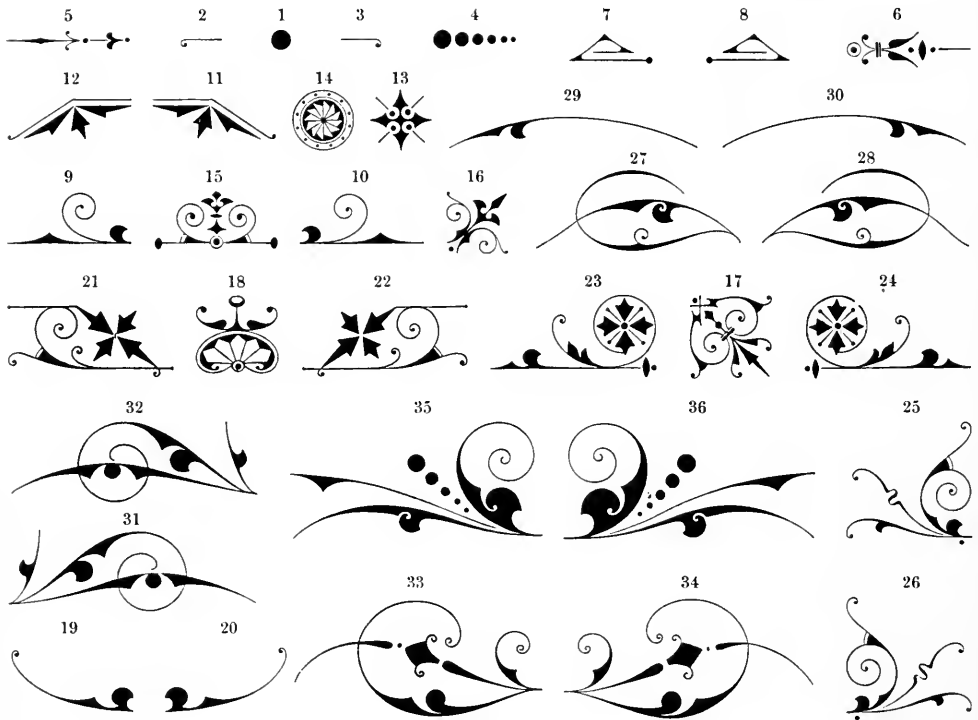

APPLE BLOSSOM ORNAMENTS

WHOLE FONT \$3 00
HALF FONT \$1 75

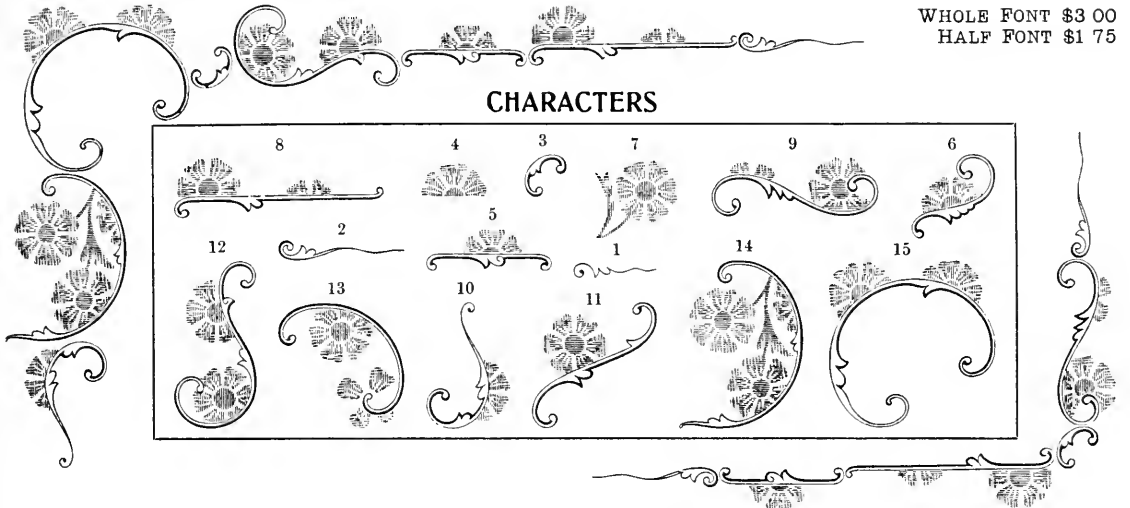

RULE ORNAMENTS

SERIES NO 1

PER FONT \$1 10

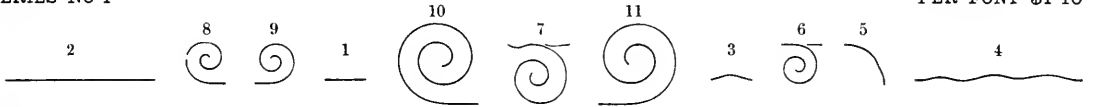

SERIES NO 2

PER FONT \$1 10

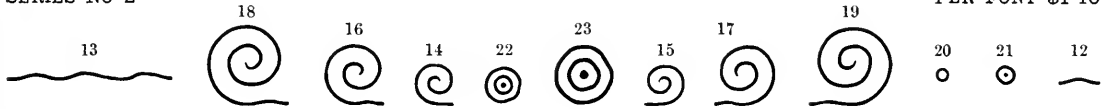

SERIES NO 3

PER FONT \$1 25

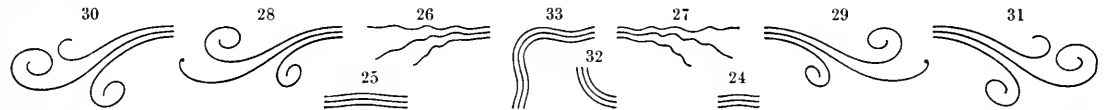

SERIES NO 4

PER FONT \$1 00

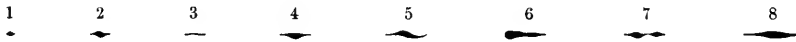

SCROLL CORNER ORNAMENTS

PER FONT \$3 00

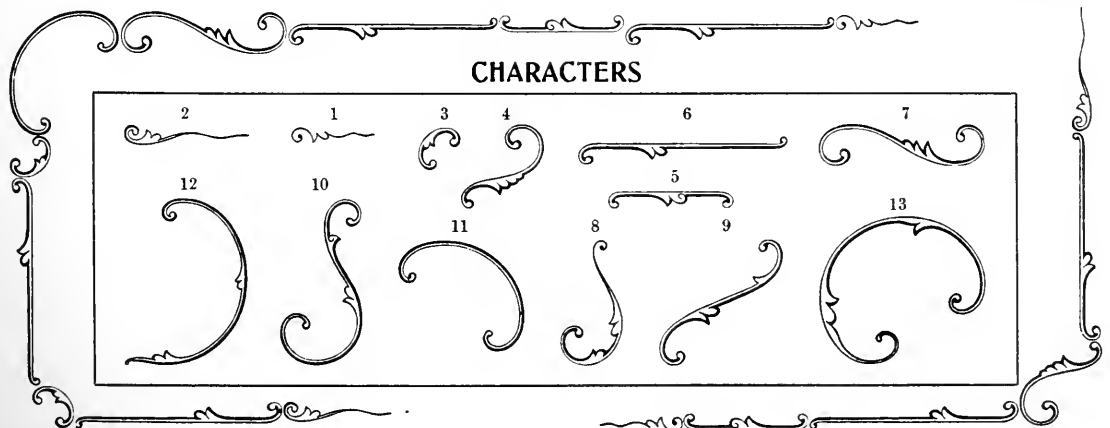

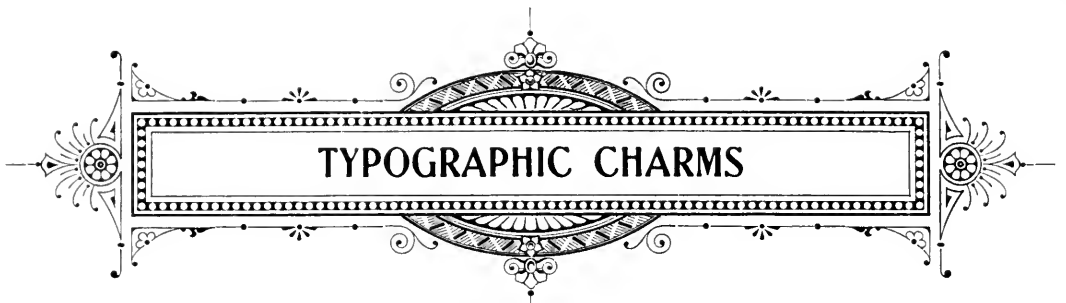

PATENTED

PRICE PER FONT \$6 50

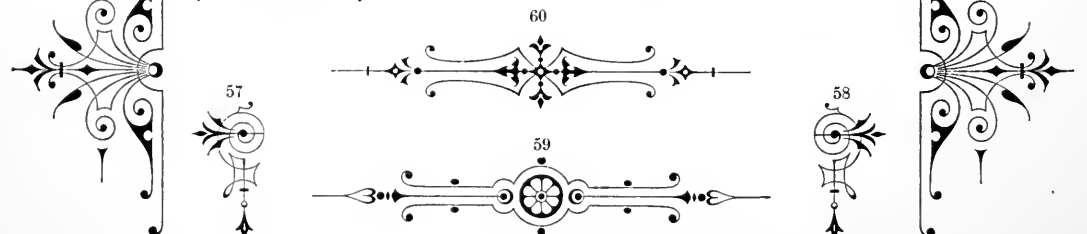
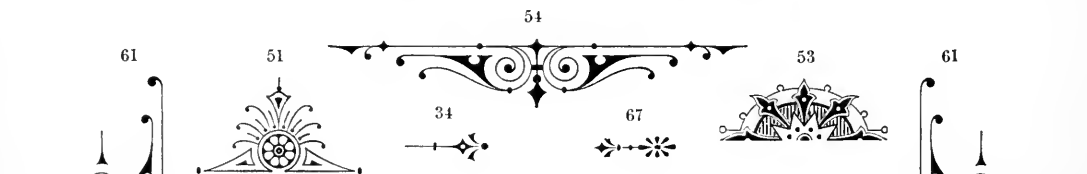
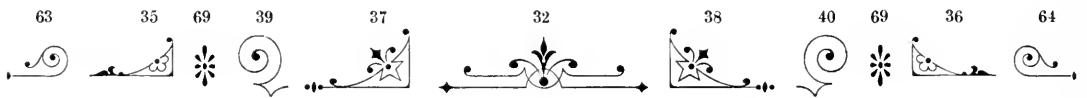
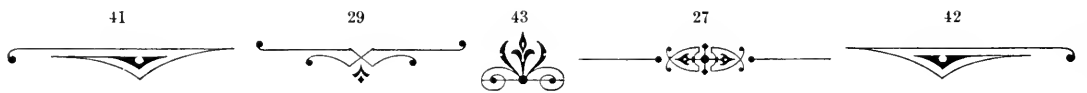
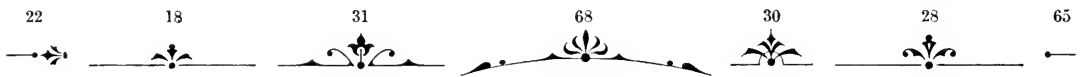
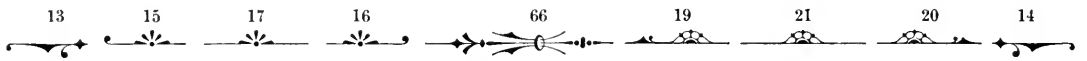
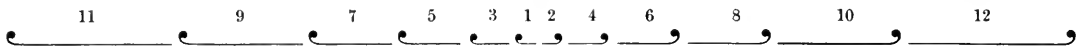

CARD ORNAMENTS

COMPLETE FONT

\$3 75

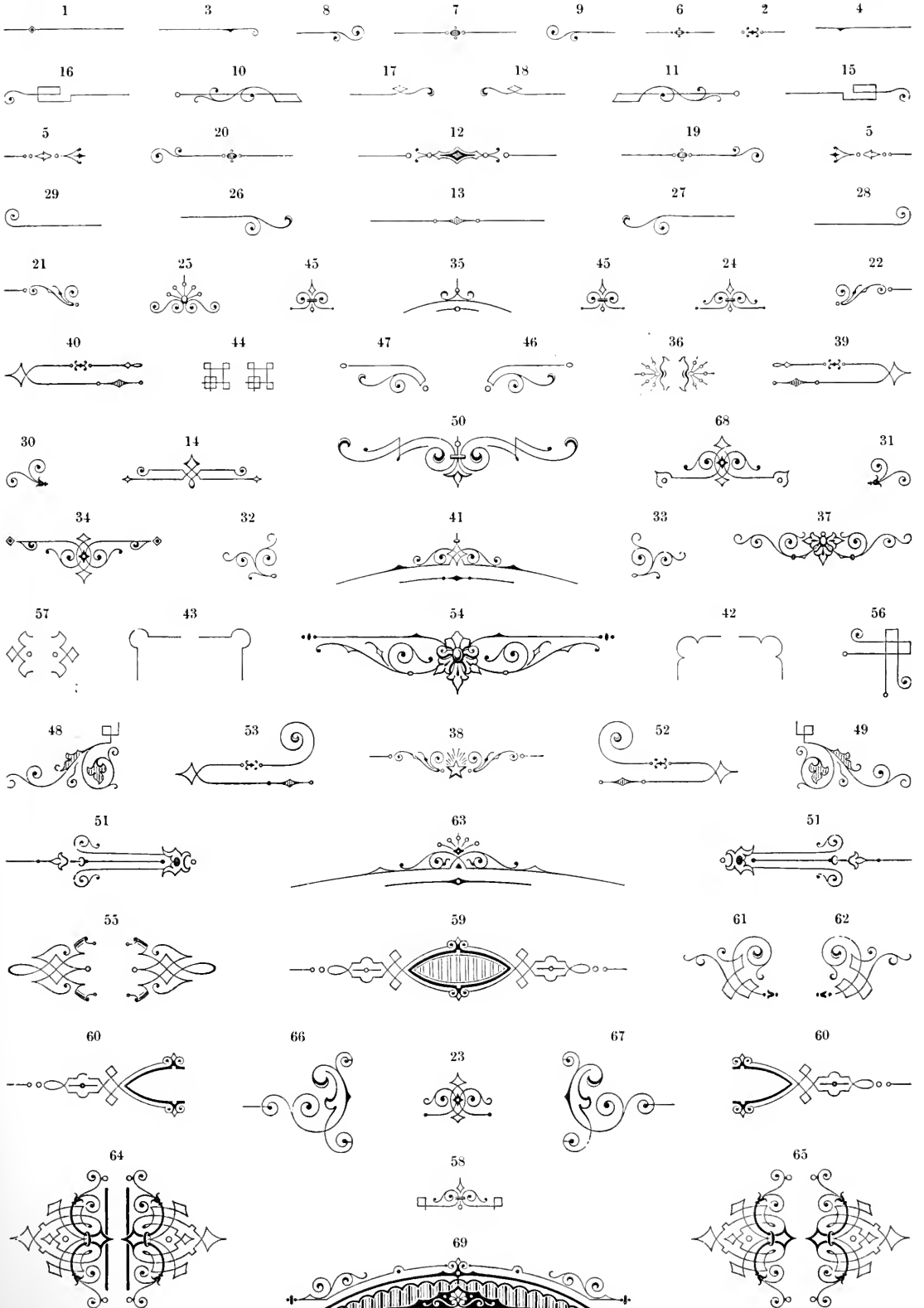

CENTRAL ORNAMENTS

SERIES No 4

PER FONT \$2 00

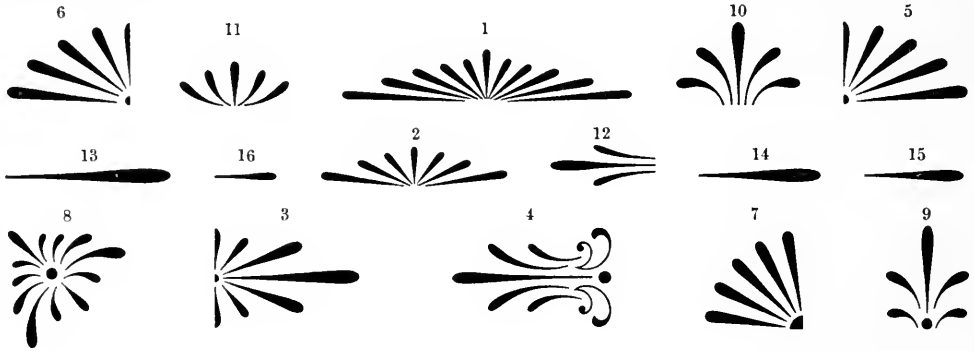

SERIES No 5

PER FONT \$2 00

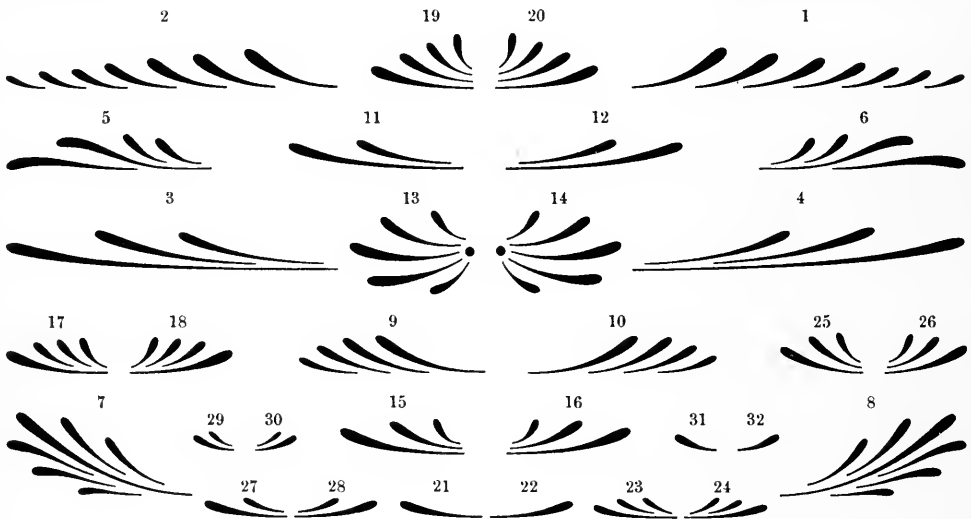

SERIES No 6

PER FONT \$2 00

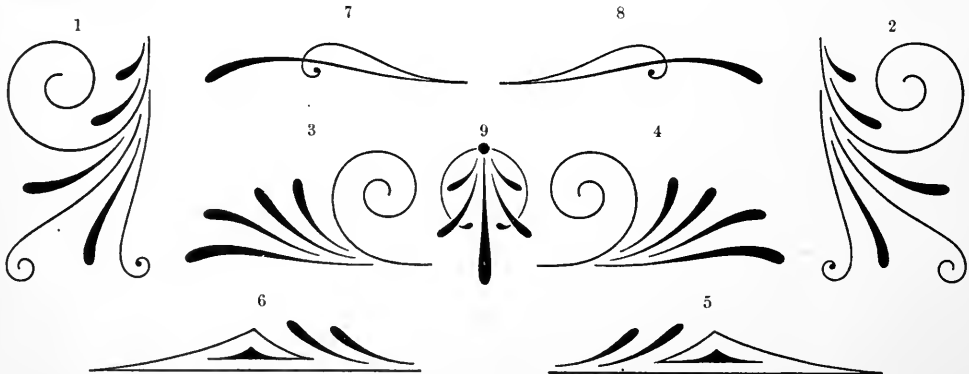

HAPPY THOUGHTS

GROUP F

Each character put up in sets of four at 40 cents per set

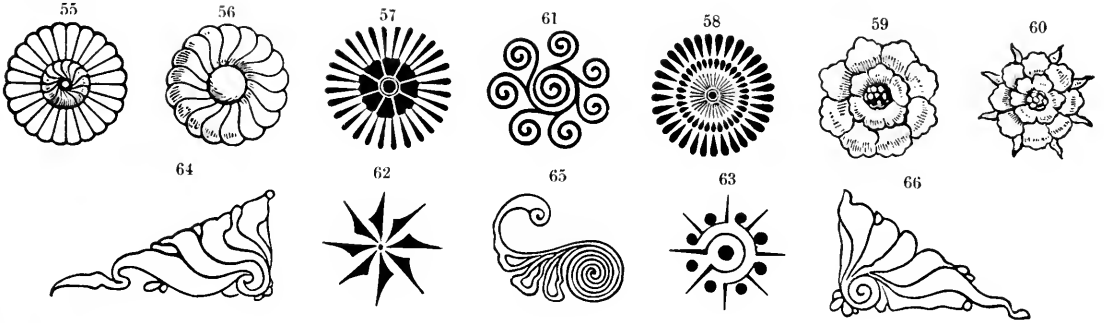

GROUP K

Each character put up in sets of four at 50c. per set

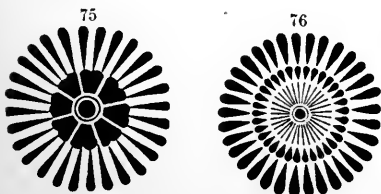
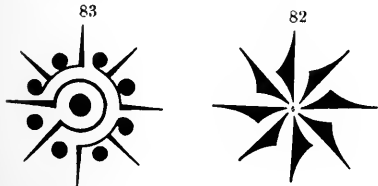
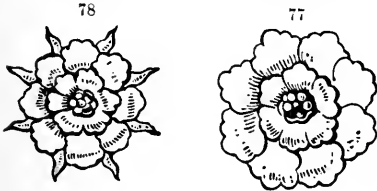
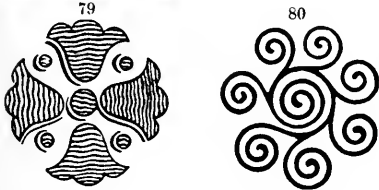
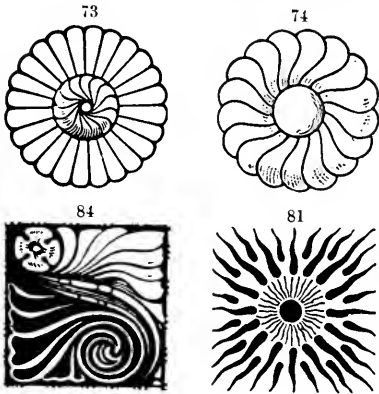

GROUP G

Each character 40 cents singly



GROUP E

Each character 35 cents singly

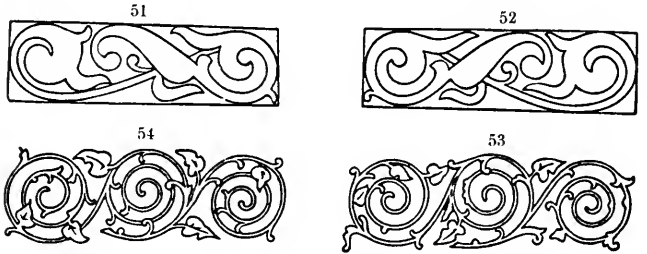

GROUP L

Each character put up in sets of four at 40 cents per set



GROUP H

Each character put up in sets of four at 50 cents per set

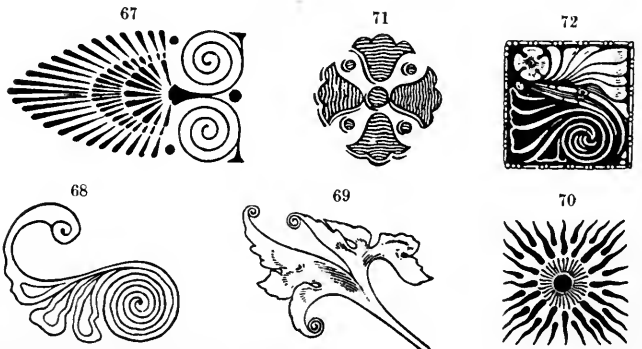



PALM BORDER

Mortised Point Bodies

FONT OF 30 INCHES \$3 00

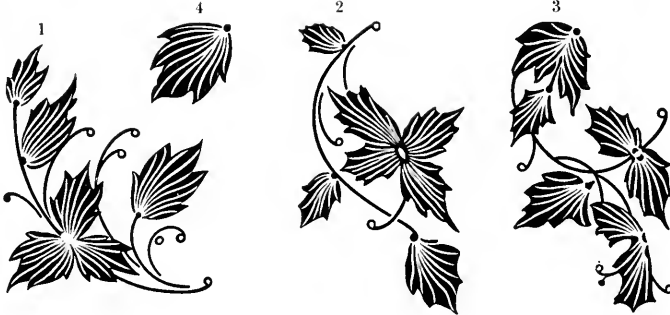

TWINKLERS

Cast on 6, 12, 18, 24 and 36 Point bodies

PER FONT \$1 00

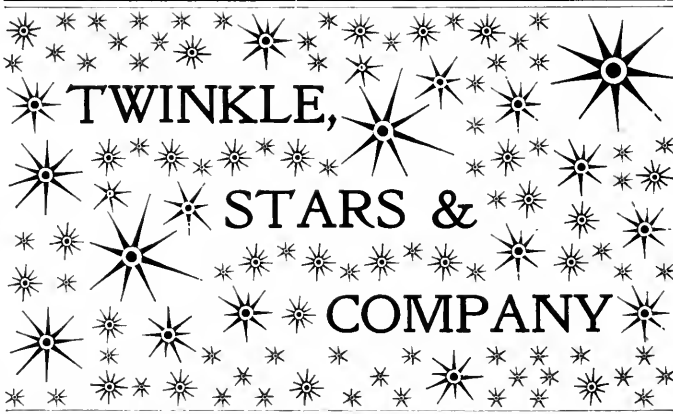
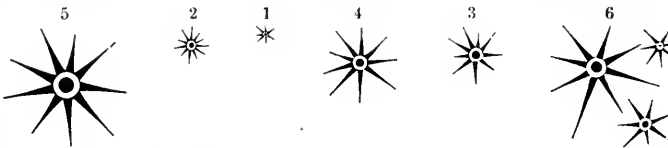

Twinklers can be utilized as quickly as ordinary quads

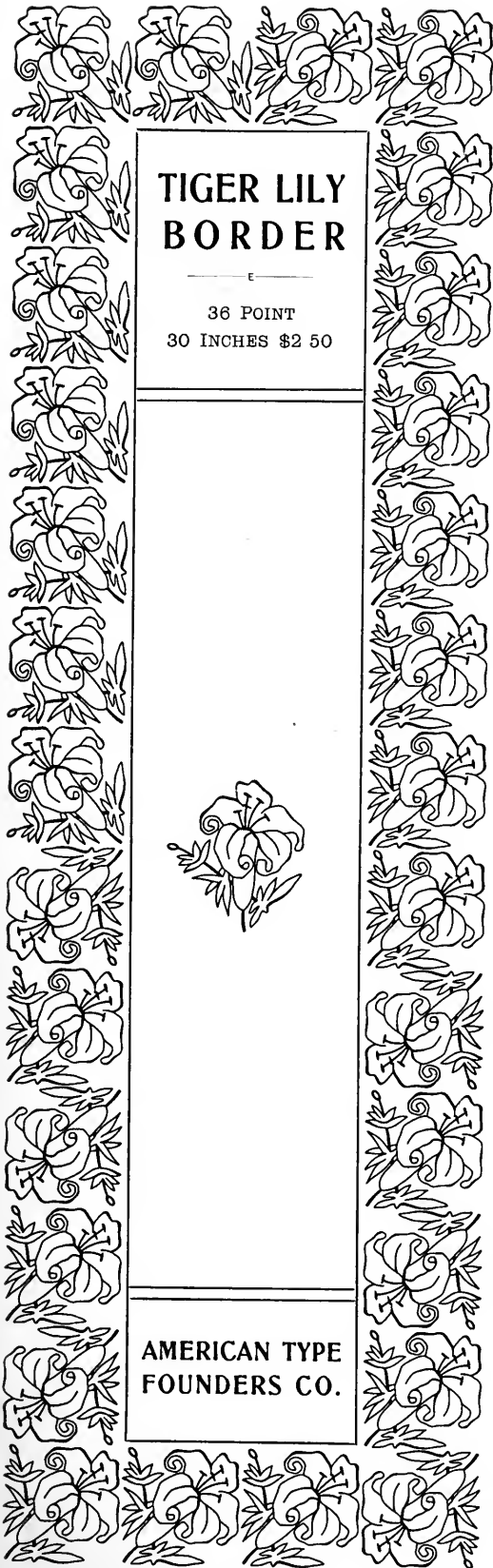

TIGER LILY BORDER

36 POINT
30 INCHES \$2 50



AMERICAN TYPE
FOUNDERS CO.

TWINKLER BORDERS

6 POINT NO 155 10 FEET \$2 60

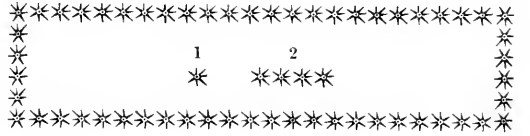

12 POINT NO 156 5 FEET \$1 75

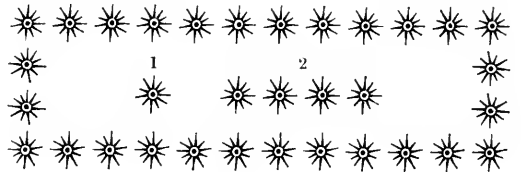

12 POINT NO 157 5 FEET \$1 75

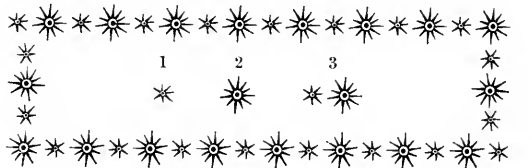

18 POINT NO 158 4 FEET \$3 10

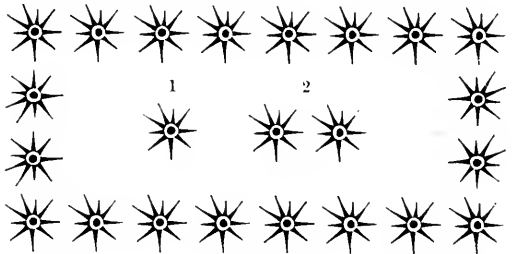

18 POINT NO 159 4 FEET \$3 10

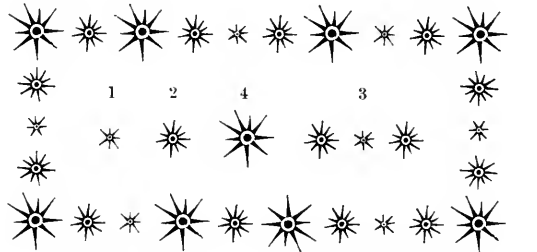

18 POINT NO 160 4 FEET \$3 10

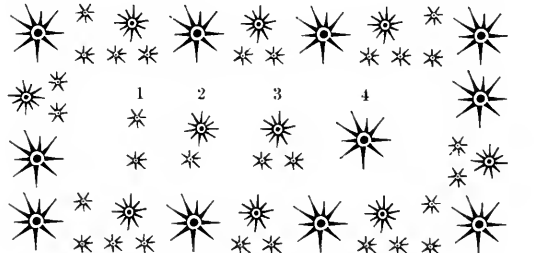

POINT COMBINATION BORDER SERIES A

A Needful Toilet Article

COMPLEXION'S
Face Cream

A SURE CURE FOR
Rough, Oily Skin, Chapped Hands,
Pimples, Sunburn, etc.

\$ 1.00

Wm. Lorenzo's

Celebrated
SOAPINE

25 Cents per Box

Sold only by

CHARACTERS

15 14 12 13 16
10 9 11

PRICE PER FONT \$3 00

GUA

MEDICATED
LOZENGES

INDISPENSABLE TO
*Clergymen, Public Speakers,
Singers and others*

5 Cents the Box

arrh

Sneezer's
SNUFF

10 Cents per Box

NEW YORK

reet
A

POINT COMBINATION BORDER SERIES B.

On the Market 20 Years

PARISIANA

Powder

HIGHLY SCENTED

50 Cents per Box

Guarantee With Every Box

SHINEMUP'S

Shoe Blacking

5 Cents per Box

H

PHIA

CHARACTERS

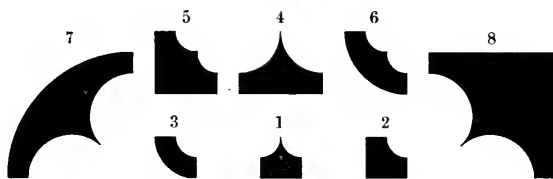

PRICE PER FONT \$3 00

Made

STEEL

DR. CUREMALL'S

Tap Drops

A SURE CURE FOR

Coughs and Colds

10 Cents a Box

This Box Contains

Fine Pins

ONE THOUSAND

MADE BY THE

Memo Pin Co.

HAPGOOD FLORETS

CAST ON 48 POINT BODY
SINGLE CHARACTER 25 CENTS

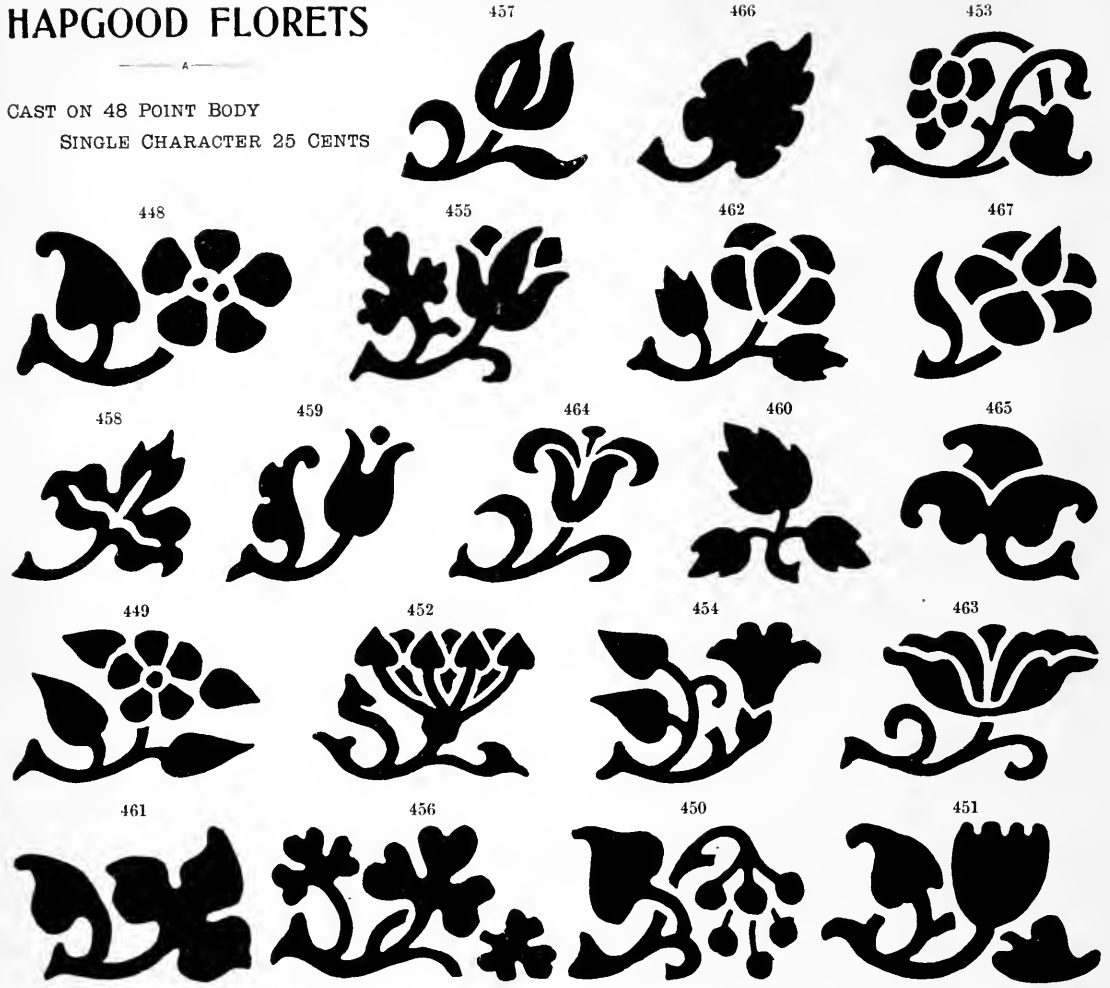

ROGERS EMBELLISHMENTS

COMPLETE ASSORTMENT \$3 00

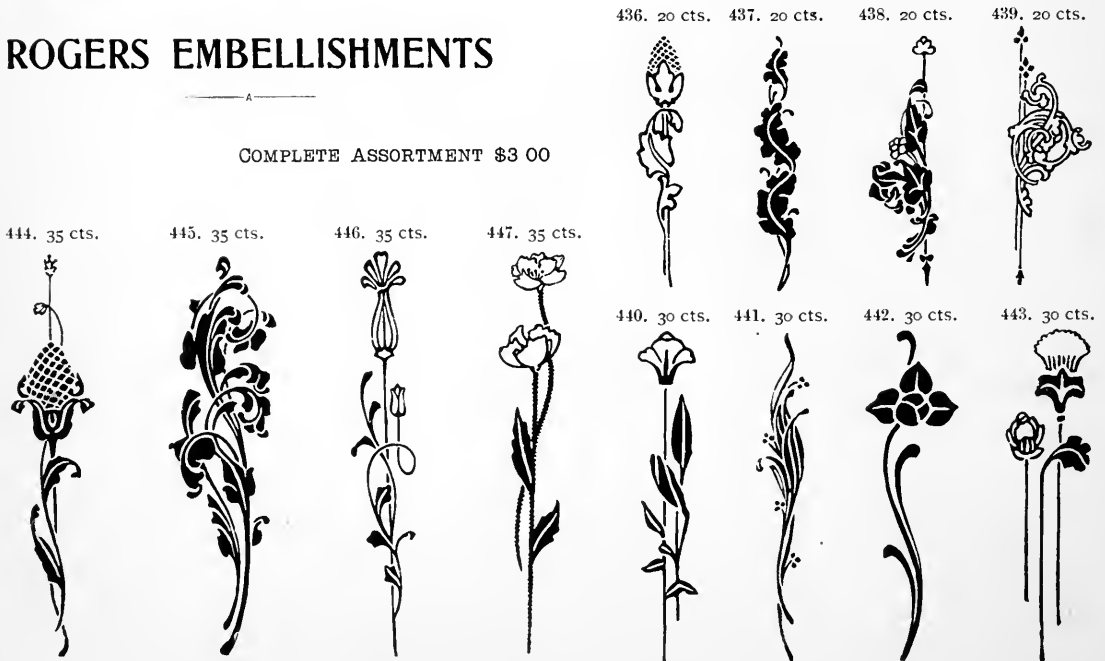

ELZEVIR FLORETS

GROUP A

PER FONT \$1 50

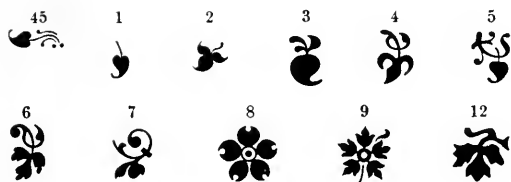

GROUP B

PER FONT \$1 50

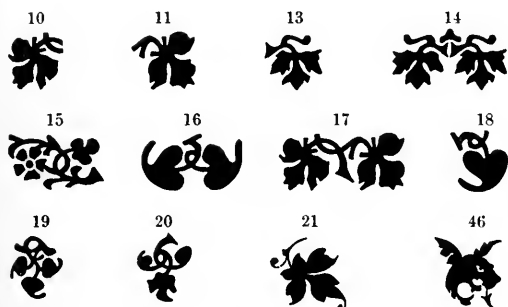

GROUP C

PER FONT \$2 00

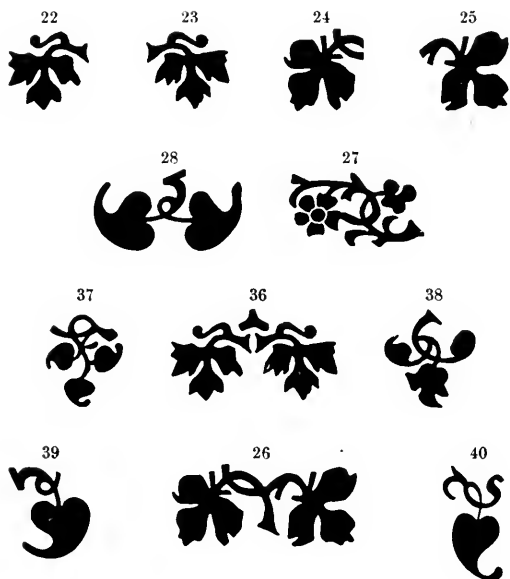

GROUP D

PER FONT \$2 00

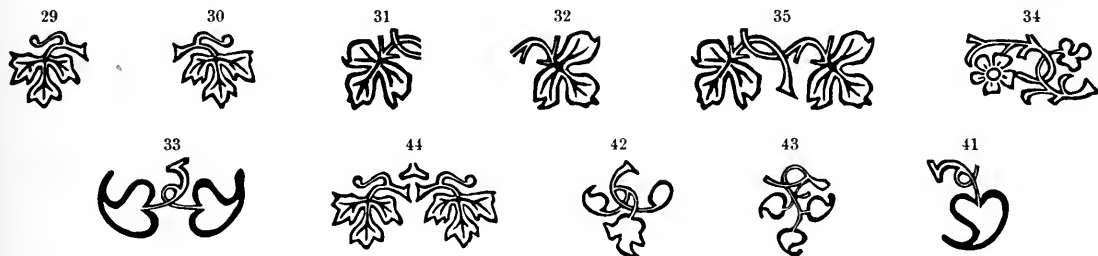

*Florets of Groups C and D are made for printing over each other in different colors
See page 755 for color effect.*

ACANTHINE FLORETS

PER FONT OF 40 PIECES, FOUR OF EACH, \$2 00

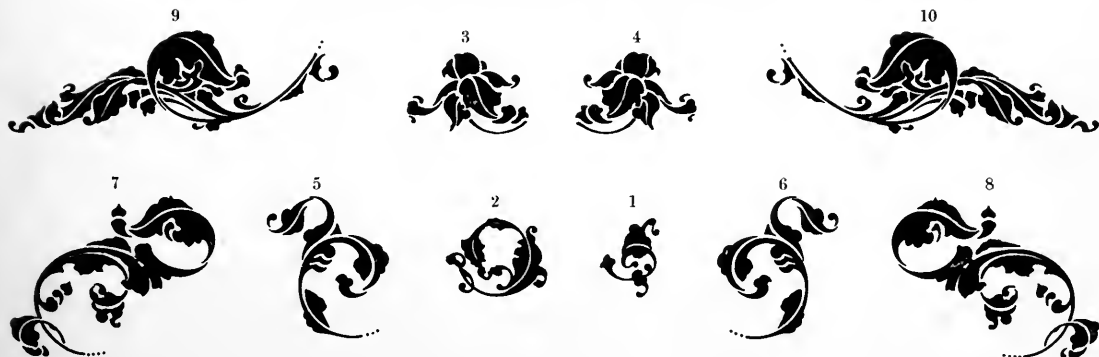

COLLINS FLORETS

GROUP M

FOUR OF ONE CHARACTER, 30 CTS. PER FONT \$2 00

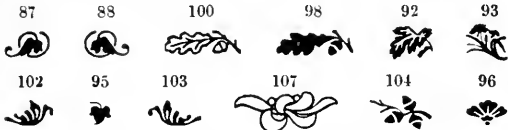

GROUP N

FOUR OF ONE CHARACTER, 40 CTS PER FONT \$3 00

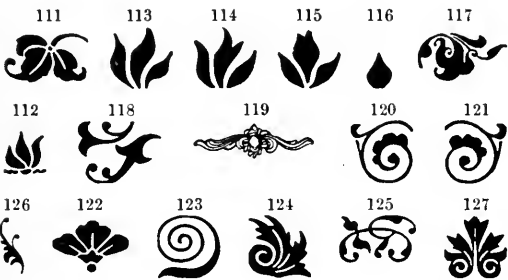

GROUP O

FOUR OF ONE CHARACTER, 40 CTS. PER FONT \$3 00

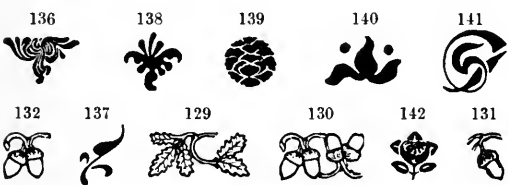

GROUP P

FOUR OF ONE CHARACTER, 40 CENTS

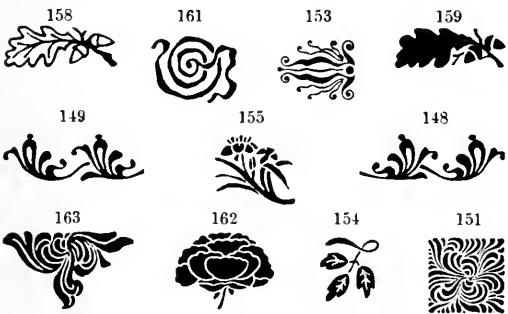

FOUR OF ONE CHARACTER, 50 CENTS



GROUP R

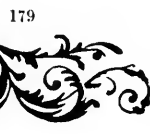

TWO OF ONE CHARACTER, 30 CENTS



FOUR OF ONE CHARACTER, 40 CENTS



GROUP Q



TWO OF ONE CHARACTER, 25 CENTS



GROUP V

FOUR OF ONE CHARACTER, 30 CTS. PER FONT \$1 50



GROUP X

FOUR OF ONE CHARACTER, 40 CTS. PER FONT \$2 50

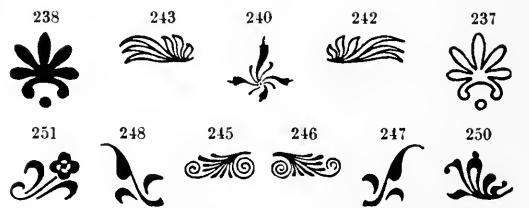

GROUP W

FOUR OF ONE CHARACTER, 40 CTS. PER FONT \$2 50

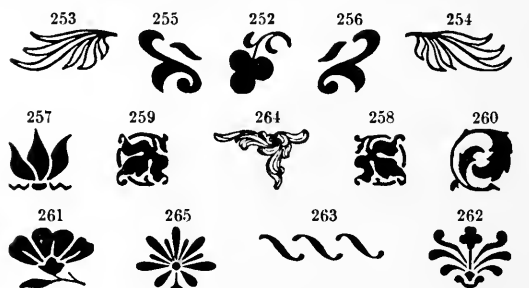

GROUP Y

FOUR OF ONE CHARACTER, 40 CENTS

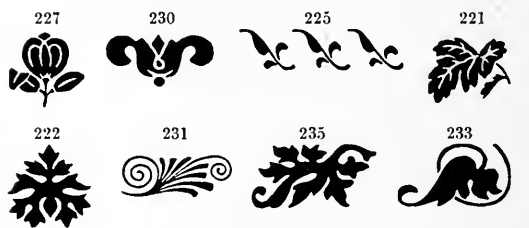

COLLINS FLORETS

202. 30 cts.



204. 30 cts.



194. 40 cts.



195. 40 cts.



185. 30 cts.



186. 30 cts.



160.

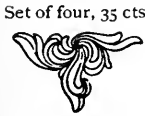

228.



178. Set of four, 50 cts.



212. Set of four, 50 cts.



18

Set of four, 50 cts.



206. 30 cts.



205. 30 cts.



187. 30 cts.



184. 30 cts.



207. 30 cts.



208. 40 cts.



199. 40 cts.



190. 30 cts.



196. 40 cts.

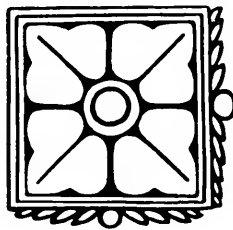

193. 40 cts.

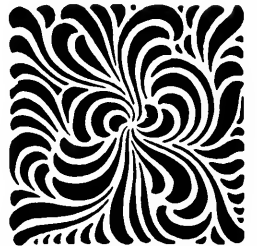

201. 40 cts.

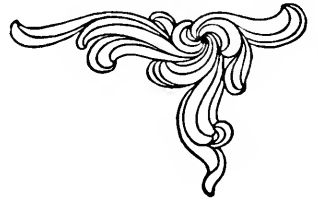

191. 30 cts.



172. Set of four, 50 cts.



192. 30 cts.

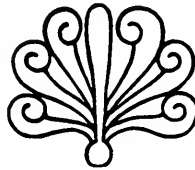

183. 30 cts.



188. 30 cts.



216.



181.



218.



189. 30 cts.



211.

Set of four, 50 cts.



278.

Set of four, 35 cts.



173.

Set of four, 50 cts.



143.

Set of four, 35 cts.



144.

Set of four, 35 cts.



215.

Set of four, 50 cts.



WAYSIDE ORNAMENTS

Cast in type mould

No. 319A. 30 cts.



No. 435A. 20 cts.



No. 420A. 20 cts.



No. 320A. 30 cts.



No. 338A. 30 cts.

No. 424A. 20 cts.



No. 425A. 20 cts.



No. 429A. 20 cts.



No. 430A. 20 cts.



No. 410A. 20 cts.



No. 409A. 20 cts.



No. 417A. 20 cts.



No. 373A. 15 cts.



No. 374A. 15 cts.



No. 350A. 30 cts.



No. 371A. 30 cts.



No. 366A. 25 cts.



No. 358A. 30 cts.



No. 393A. 30 cts.



No. 394A. 30 cts.



No. 346A. 30 cts.



No. 347A. 30 cts.



No. 336A. 30 cts.



No. 337A. 30 cts.



No. 326A. 30 cts.



No. 335A. 50 cts.



No. 330A. 30 cts.

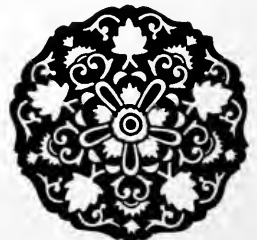

WAYSIDE ORNAMENTS

Cast in type mould

No. 317A. 30 cts.



No. 323A. 30 cts.



No. 318A. 30 cts.



No. 423A. 15 cts.



No. 422A. 15 cts.



No. 388A. 20 cts.



No. 385A. 30 cts.



No. 387A. 30 cts.



No. 389A. 20 cts.



No. 325A. 30 cts.



No. 340A. 50 cts.



No. 327A. 30 cts.



No. 432A. 20 cts.



No. 431A. 20 cts.



No. 354A. 30 cts.



No. 360A. 20 cts.



No. 372A. 25 cts.



No. 361A. 20 cts.



No. 355A. 30 cts.



No. 328A. 30 cts.

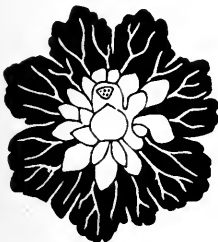

No. 341A. 50 cts.

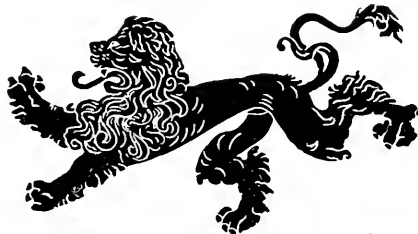

No. 333A. 30 cts.



No. 406A. 20 cts.



No. 416A. 20 cts.



No. 391A. 20 cts.



No. 390A. 20 cts.



No. 421A. 20 cts.



No. 418A. 20 cts.



WAYSIDE EMBELLISHMENTS

Electrotyped

No. 4352A. 75 cts.



No. 4339A. 60 cts.



No. 4351A. 75 cts.



No. 4471A. \$1.00



No. 4469A.
50 cts.



No. 4470A.
50 cts.



No. 4350A. 60 cts.



No. 4346A. 75 cts.



No. 4472A. 60 cts.



No. 4345A. 75 cts.



WAYSIDE EMBELLISHMENTS

Electrotypes

No. 4189C. 50c.
Per pair, 85c.



No. 4343A. 60 cts.



No. 4341A. 60 cts.



No. 4340A. 60 cts.



No. 4347A. \$1.00



No. 4342A. 50 cts.

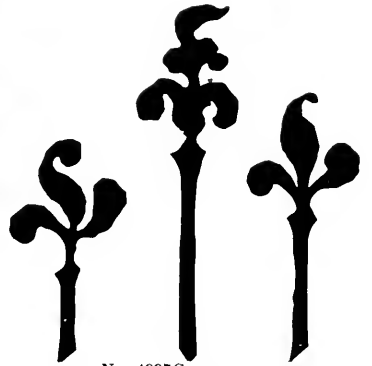

No. 4997C. 50 cts.

SCHÖEFFER ORNAMENTS

Electrotypes

PER SET \$1 00

No. 4998C. 50 cts.

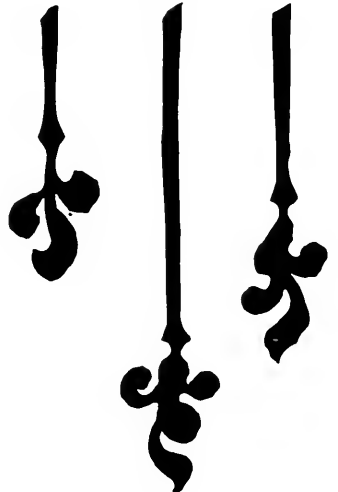

EMPIRE ORNAMENTS

Cast in type mould

36 POINT

PER FONT 75 CENTS



48 POINT

PER FONT \$1 00



“POST” ORNAMENTS

Order by Name and No.

Electrotypes blocked on kilndried cherry wood, excepting the smaller designs (indicated by an asterisk) which are on solid metal point bodies.

No. 33. 35 cts.



No. 12. 40 cts.



No. 34. 35 cts.



No. 6. 35 cts.

No. 4. 35 cts.



*No. 58. 35 cts.



No. 3. 35 cts.

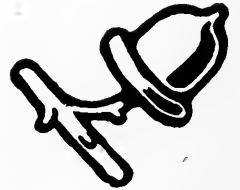

No. 1. 40 cts.

*No. 54. 35 cts.

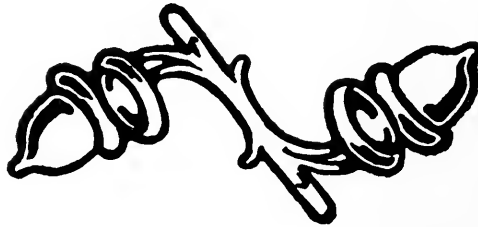

*No. 56. 35 cts.



No. 2. 35 cts.



No. 5. 35 cts.

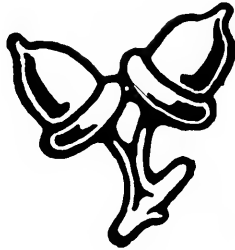

*No. 66. 30 cts.



No. 14. 35 cts.



No. 53. 35 cts.

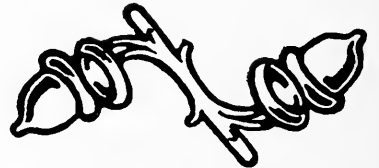

No. 15. 45 cts.



*No. 57. 35 cts.



*No. 55. 35 cts.



No. 16. 45 cts.



No. 64. 35 cts.



"POST" ORNAMENTS

Order by Name and No.

Electrotypes blocked on kilndried cherry wood, excepting the smaller designs (indicated by an asterisk) which are on solid metal point bodies.

No. 125. 50 cts.

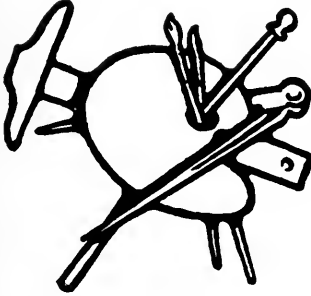

No. 117. 50 cts.

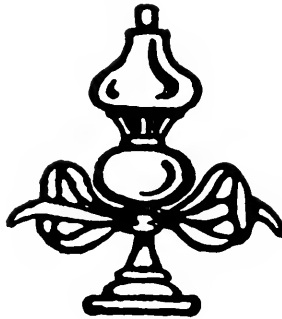

No. 114. 40 cts.

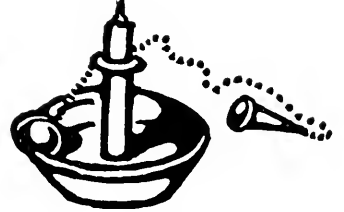

No. 123. 50 cts.



No. 101. 40 cts.

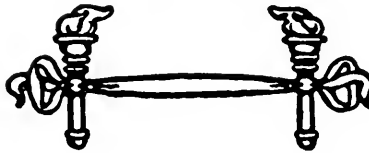

No. 102. 40 cts.

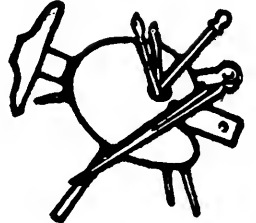

No. 105. 40 cts.



No. 96. 40 cts.



No. 121. 50 cts.

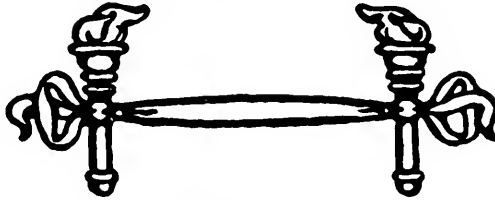

No. 100. 35 cts.



No. 120. 50 cts.



No. 103. 40 cts.



No. 94. 35 cts.



No. 97. 40 cts.



No. 122. 60 cts.



No. 116. 40 cts.



“POST” ORNAMENTS

Order by Name and No.

Electrotypes blocked on kilndried cherry wood, excepting the smaller designs (indicated by an asterisk) which are on solid metal point bodies.

No. 30. 50 cts.



No. 31. 50 cts.

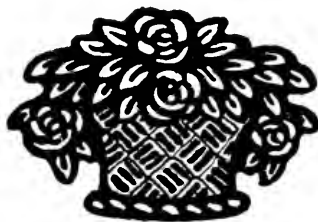

No. 32. 50 cts.



No. 25. 60 cts.



No. 141. 40 cts.



No. 26. 60 cts.

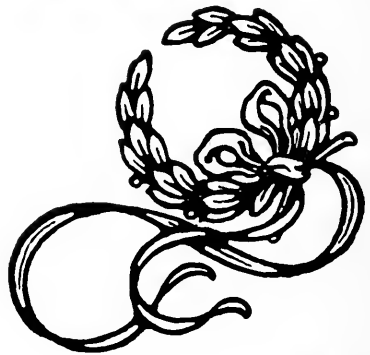

*No. 107. 35 cts.



No. 28. 40 cts.



No. 29. 40 cts.



*No. 109. 25 cts.



No. 137. 40 cts.



*No. 110. 25 cts.



No. 140. 40 cts.



No. 27. 50 cts.



No. 142. 40 cts.



No. 135. 45 cts.



No. 138. 35 cts.



No. 139. 35 cts.



*No. 108. 30 cts.



SERIES A

6 POINT PER FONT 35 CENTS

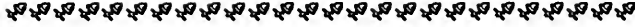

8 POINT PER FONT 35 CENTS

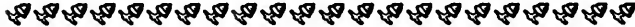

10 POINT PER FONT 40 CENTS



12 POINT PER FONT 40 CENTS



14 POINT PER FONT 50 CENTS



18 POINT PER FONT 60 CENTS



24 POINT PER FONT 70 CENTS



30 POINT PER FONT 80 CENTS



36 POINT PER FONT 90 CENTS



42 POINT PER FONT \$1 00



48 POINT PER FONT \$1 15



SE

6 POINT



8 POINT



10 POINT



12 POINT



14 POINT



18 POINT



24 POINT



30 POINT



36 POINT



42 POINT



48 POINT



“Post” Bands are pu

"POST" ORNAMENTS

Order by Name and No.

| | | | | | | | | | | | | | |
|------------------|------------------|------------------|------------------|------------------|------------------|------------------|------------------|------------------|------------------|------------------|------------------|------------------|------------------|
| No. 172, 50 cts. | No. 171, 50 cts. | No. 169, 50 cts. | No. 170, 50 cts. | No. 168, 50 cts. | No. 167, 50 cts. | No. 173, 50 cts. | No. 194, 40 cts. | No. 192, 40 cts. | No. 193, 40 cts. | No. 197, 40 cts. | No. 198, 40 cts. | | |
| | | | | | | | | | | | | | |
| No. 179, 60 cts. | No. 180, 50 cts. | No. 177, 50 cts. | No. 182, 50 cts. | No. 174, 50 cts. | No. 176, 50 cts. | No. 181, 50 cts. | No. 175, 50 cts. | No. 178, 50 cts. | No. 195, 40 cts. | No. 189, 40 cts. | No. 186, 40 cts. | No. 184, 40 cts. | No. 196, 40 cts. |
| | | | | | | | | | | | | | |
| No. 152, 60 cts. | No. 157, 60 cts. | No. 154, 60 cts. | No. 156, 60 cts. | No. 151, 60 cts. | No. 155, 60 cts. | No. 153, 60 cts. | No. 187, 40 cts. | No. 190, 40 cts. | No. 185, 40 cts. | No. 191, 40 cts. | No. 188, 40 cts. | No. 183, 40 cts. | |
| | | | | | | | | | | | | | |
| No. 159, 60 cts. | No. 166, 60 cts. | No. 164, 60 cts. | No. 165, 60 cts. | No. 160, 60 cts. | No. 161, 60 cts. | No. 158, 60 cts. | No. 162, 60 cts. | No. 163, 60 cts. | | | | | |
| | | | | | | | | | | | | | |

"POST" BANDS

SERIES A

8 POINT PER FONT 35 CENTS

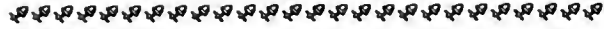

8 POINT PER FONT 35 CENTS

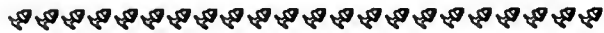

10 POINT PER FONT 40 CENTS



12 POINT PER FONT 40 CENTS



14 POINT PER FONT 50 CENTS



18 POINT PER FONT 80 CENTS



24 POINT PER FONT 70 CENTS



30 POINT PER FONT 80 CENTS



36 POINT PER FONT 90 CENTS



42 POINT PER FONT \$1 00



48 POINT PER FONT \$1 15



SERIES B

6 POINT PER FONT 35 CENTS



8 POINT PER FONT 35 CENTS



10 POINT PER FONT 40 CENTS



12 POINT PER FONT 40 CENTS



14 POINT PER FONT 50 CENTS



18 POINT PER FONT 60 CENTS



24 POINT PER FONT 70 CENTS



30 POINT PER FONT 80 CENTS



36 POINT PER FONT 90 CENTS



42 POINT PER FONT \$1 00



48 POINT PER FONT \$1 15



SERIES C

6 POINT PER FONT 35 CENTS



8 POINT PER FONT 35 CENTS



10 POINT PER FONT 40 CENTS



12 POINT PER FONT 40 CENTS



14 POINT PER FONT 50 CENTS



18 POINT PER FONT 80 CENTS



24 POINT PER FONT 70 CENTS



30 POINT PER FONT 80 CENTS



36 POINT PER FONT 90 CENTS



42 POINT PER FONT \$1 00



48 POINT PER FONT \$1 15



"Post" Bands are put up in Twelve-Inch Fonts

"POST" ORNAMENTS

Order by Name and No.

Electrotypes blocked on kilndried cherry wood, excepting the smaller designs (indicated by an asterisk) which are on solid metal point bodies.

No. 22. 50 cts.



No. 111. 75 cts.



No. 21. 50 cts.



*No. 129. 35 cts.



No. 23. 40 cts.



*No. 19. 40 cts.



No. 24. 40 cts.



No. 91. 50 cts.



No. 128. 50 cts.



No. 92. 40 cts.



No. 132. 40 cts.



No. 131. 40 cts.



No. 134. 35 cts.



No. 20. 60 cts.



No. 133. 35 cts.



No. 18. 60 cts.



No. 17. 75 cts.

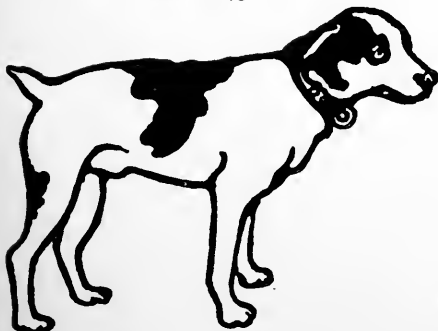

No. 127. 60 cts.



"POST" ORNAMENTS

Order by Name and No.

Electrotypes blocked on kilndried cherry wood, excepting the smaller designs (indicated by an asterisk) which are on solid metal point bodies.

No. 46. 40 cts.

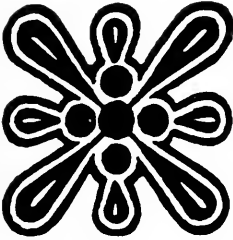

No. 84. 50 cts.

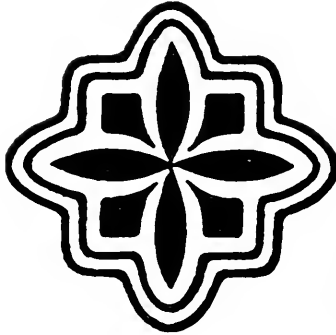

No. 85. 40 cts.

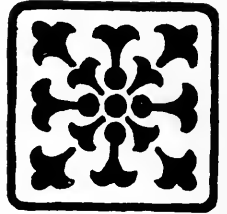

No. 50. 35 cts.

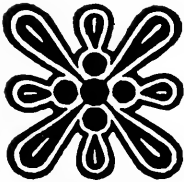

No. 112. 50 cts.



No. 93. 50 cts.



*No. 89. 35 cts.

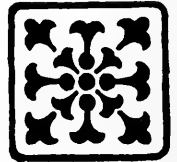

No. 113. 60 cts.



No. 99. 40 cts.



*No. 52. 35 cts.

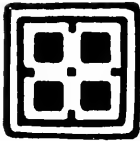

No. 83. 40 cts.



*No. 90. 40 cts.

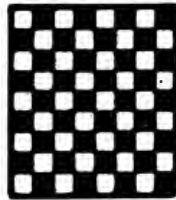

*No. 86. 60 cts.

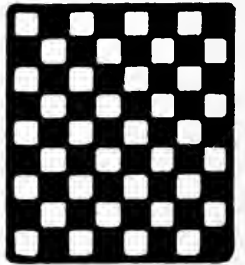

No. 106. 30 cts.



No. 124. 45 cts.



No. 45. 40 cts.



No. 88. 40 cts.



No. 119. 40 cts.



No. 48. 35 cts.

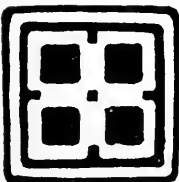

*No. 87. 35 cts.



*No. 49. 35 cts.



*No. 51. 35 cts.



No. 47. 40 cts.



"POST" ORNAMENTS

Order by Name and No.

Electrotypes blocked on kilndried cherry wood, excepting the smaller designs (indicated by an asterisk) which are on solid metal point bodies.

No. 81. 35 cts.



*No. 35. 35 cts.



*No. 80. 35 cts.



*No. 79. 35 cts.



No. 38. 50 cts.



*No. 126. 50 cts.



No. 73. 40 cts.



*No. 82. 40 cts.

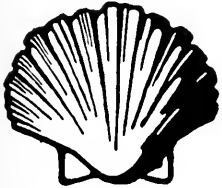

*No. 76. 35 cts.



*No. 36. 40 cts.



No. 39. 40 cts.

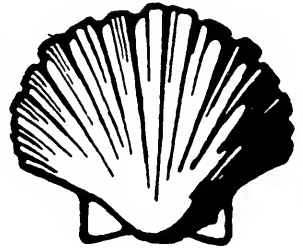

No. 37. 40 cts.



No. 41. 35 cts.



*No. 78. 30 cts.



No. 40. 45 cts.

*No. 95. 45 cts.



*No. 74. 35 cts.



No. 44. 40 cts.



*No. 77. 35 cts.

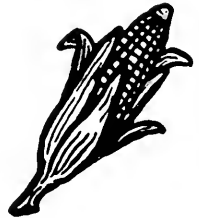

*No. 98. 40 cts.



*No. 104. 35 cts.



No. 75. 30 cts.



No. 43. 45 cts.



No. 118. 50 cts.



No. 42. 50 cts.



No. 115. 50 cts.



“POST” ORNAMENTS

Order by Name and No.

Electrotypes blocked on kilndried cherry wood, excepting the smaller designs (indicated by an asterisk) which are on solid metal point bodies.

No. 9. 50 cts.

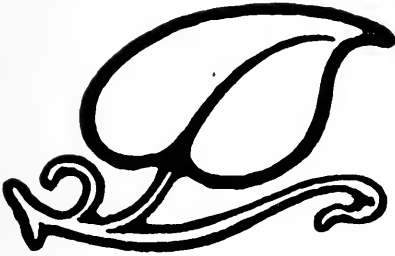

No. 62. 35 cts.

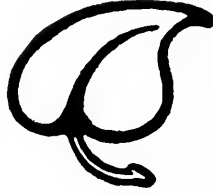

No. 10. 40 cts.



No. 59. 40 cts.



No. 11. 45 cts.



No. 60. 40 cts.

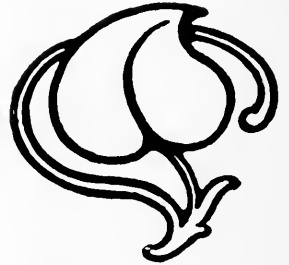

*No. 68. 40 cts.



*No. 67. 40 cts.



*No. 69. 40 cts.



*No. 71. 35 cts.



*No. 70. 35 cts.



*No. 72. 35 cts.



No. 65. 35 cts.



No. 13. 40 cts.



No. 61. 40 cts.

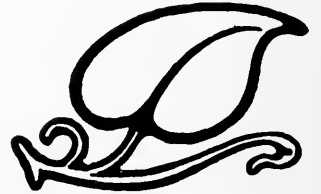

No. 7. 50 cts.



No. 8. 50 cts.



No. 63. 40 cts.



JENSON EMBELLISHMENTS

No. 4268. \$2.00

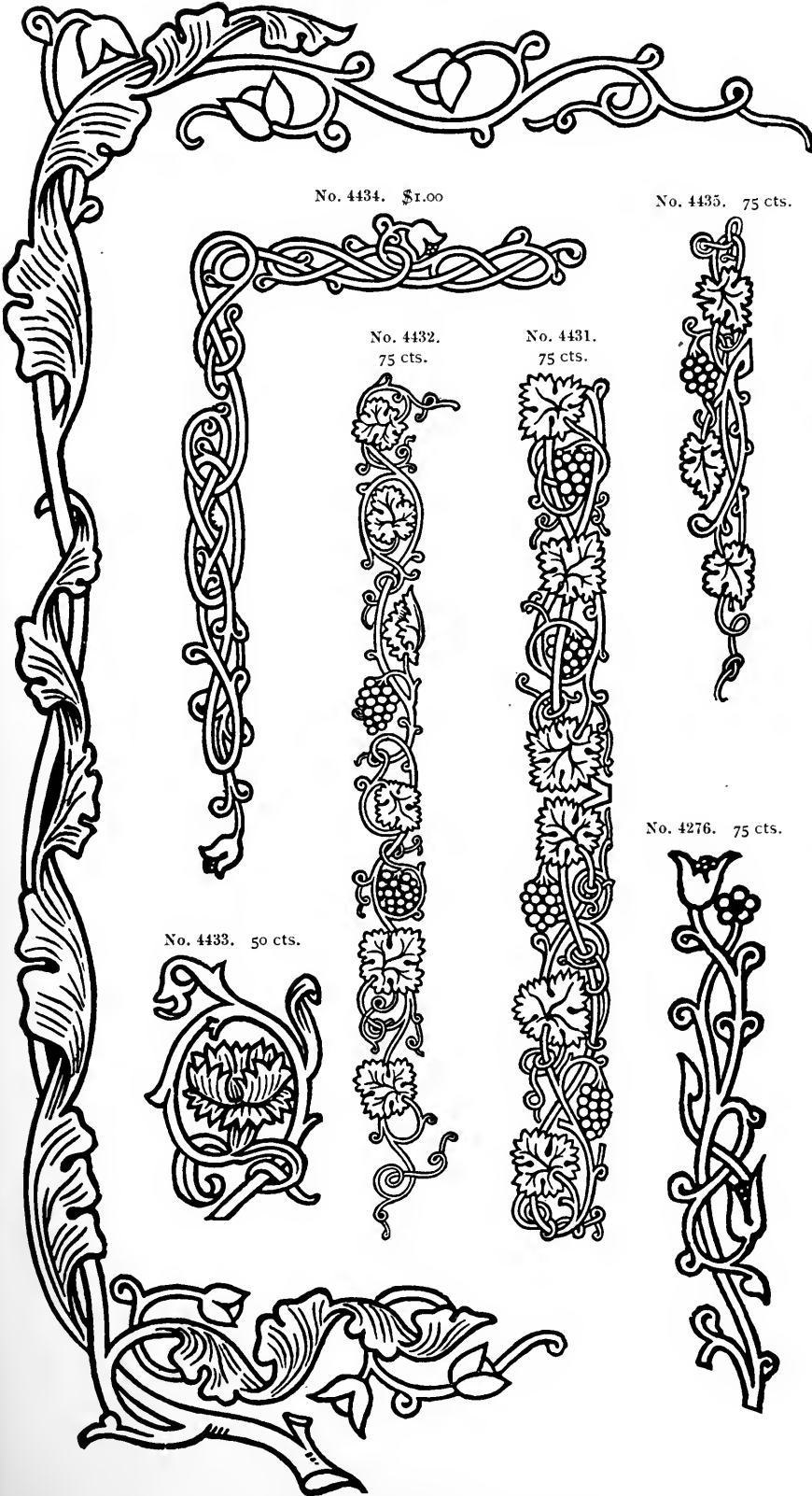

No. 4249. \$1.00



No. 4434. \$1.00



No. 4435. 75 cts.



No. 4432. 75 cts.



No. 4431. 75 cts.



No. 4433. 50 cts.

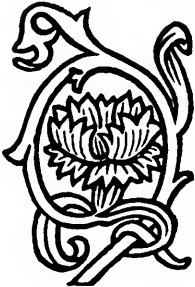

No. 4276. 75 cts.



JENSON EMBELLISHMENTS

— A —



No. 4294. 75 cts.

No. 4257. 75 cts.

No. 4440. \$1.75



No. 4258. \$1.00



No. 4245. \$1.00

JENSON EMBELLISHMENTS



No. 4438. 75 cts.



No. 4295. \$1.00

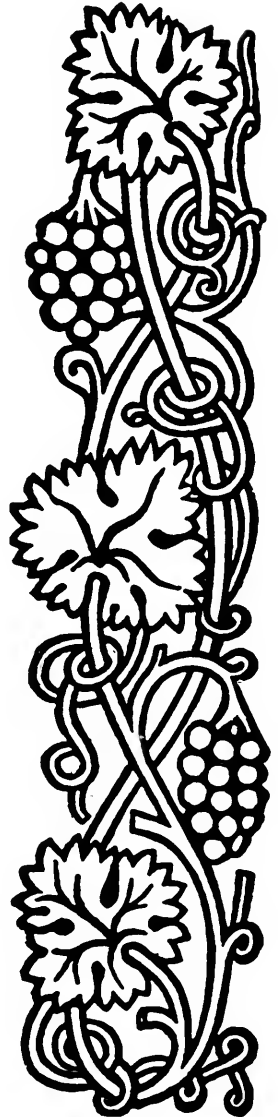

No. 4439. \$1.00



No. 4264. \$2.00

JENSON EMBELLISHMENTS



No. 4288. \$1.25

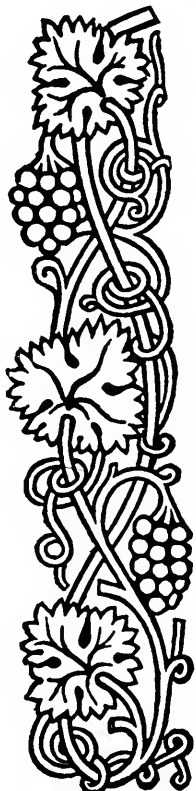

No. 4278. 75 cts.



No. 4261. \$1.00



No. 4437. \$1.00



No. 4259. \$1.00



No. 4277. \$1.25



No. 4436. 75 cts.

PART XVI.

Cast and Electrotyped

INITIAL LETTERS

**NEWSPAPER HEADINGS
AND
SUB-HEADINGS**

Electrotyped Date Lines

CHECK BLANKS

Commercial and Billhead Logotypes

TWO-COLOR INITIALS

*SERIES NO 321 ORNAMENTED ⁶
PER SET \$7 50 SINGLE LETTER 50 CENTS

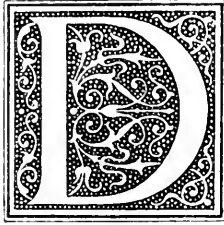
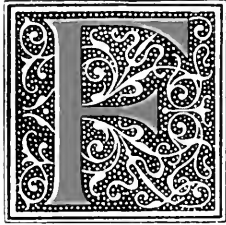

*SERIES NO 321 PLAIN ⁶
PER SET \$6 00 SINGLE LETTER 50 CENTS



*SERIES NO 320 PLAIN ⁶
PER SET \$3 50 SINGLE LETTER 35 CENTS



*SERIES NO 320 ORNAMENTED ⁶
PER SET \$5 00 SINGLE LETTER 35 CENTS



*SERIES NO 52 ^D
PER SET \$7 00 SINGLE LETTER 60 CENTS



*SERIES NO 1148 ^D
PER SET \$3 50 SINGLE LETTER 30 CENTS

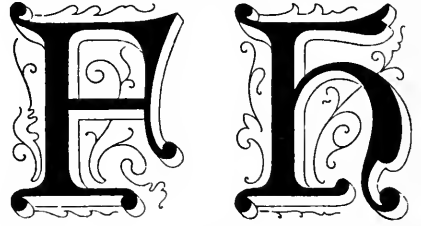

*SERIES NO 1147 ^D
PER SET \$2 25
SINGLE LETTER 25 CENTS



*SERIES NO 50 ^D
PER SET \$3 50
SINGLE LETTER 40 CTS.



*SERIES NO 1146 ^D
PER SET \$1 75
SINGLE LETTER 20 CTS.



*SERIES NO 51 ^D
PER SET \$4 50
SINGLE LETTER 50 CENTS



†WAYSIDE INITIALS NO 1 ^A
PER SET 51 LETTERS \$22 50 SINGLE LETTER 60 CTS.



†WAYSIDE INITIALS NO 2 ^A
PER SET 51 LETTERS \$22 50 SINGLE LETTER 60 CTS.



†HAPGOOD INITIALS NO 2 ^A
PER SET 26 LETTERS \$10 00 SINGLE LETTER 50 CTS



†HAPGOOD INITIALS NO 1 ^A
PER SET 26 LETTERS \$10 00 SINGLE LETTER 50 CTS.

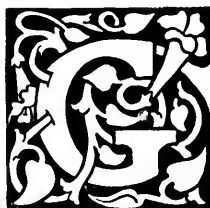

*Cast Initials

†Electrotypes Initials

ELECTROTYPED INITIALS

MORRIS SERIES NO 76 ^A

PER SET \$15 00 SINGLE LETTER 75 CENTS



MORRIS SERIES NO 77 ^A

PER SET \$12 00 SINGLE LETTER 60 CENTS

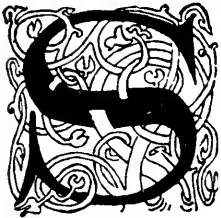

SERIES NO 1159 ^D
PER SET WITH ORNA-
MENTS \$4 50
SINGLE LETTER 40 CTS.
Each in three pieces



MORRIS SERIES NO 78 ^A PER SET \$10 00 SINGLE LETTER 50 CTS.

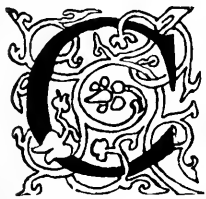

No 4140 ^A
40 CENTS



INDEX INITIALS ^C
PER SET \$10 00 SINGLE LETTER 50 CTS.

INDEX INITIALS—SECOND SERIES ^C
PER SET \$8 00 SINGLE LETTER 40 CTS.



SERIES NO 1158 ^D
PER SET \$6 00
SINGLE LETTER 50 CENTS



FIFTH INITIALS ^A
PER SET \$10 00
SINGLE LETTER 50 CENTS



SERIES NO 442 ^C
PER SET \$10 00
SINGLE LETTER 50 CENTS



ELECTROTYPED INITIALS

SERIES No 426 ° PER SET \$7 00 SINGLE LETTER 35 CENTS



ACORN SERIES No 71 ^
PER SET \$12 00
SINGLE LETTER 60 CENTS



SERIES No 425 ° PER SET \$6 00 SINGLE LETTER 30 CENTS

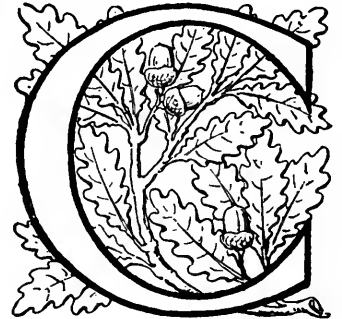

SERIES No 424 ° PER SET \$5 00 SINGLE LETTER 25 CENTS



WAVERLEY SERIES No 74 ^
SINGLE LETTER 40 CENTS

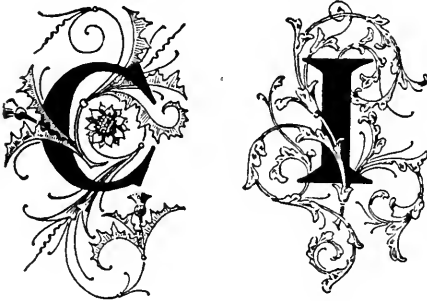

ACORN SERIES No 72 ^
PER SET \$11 00 SINGLE LETTER 50 CENTS

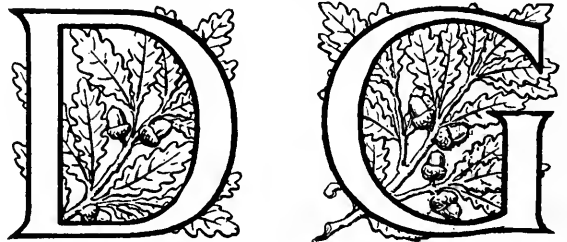

WAVERLEY SERIES No 75 ^
SINGLE LETTER 50 CENTS

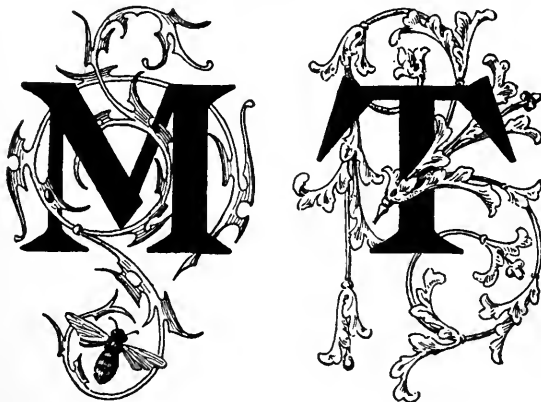

ACORN SERIES No 73 ^
PER SET \$9 00 SINGLE LETTER 40 CENTS



SERIES No 421 °
PER SET \$7 00 SINGLE LETTER 35 CENTS



ELECTROTYPED INITIALS

LENTEN SERIES No 51 ^A
PER SET \$8 00 SINGLE LETTER 35 CENTS



LENTEN SERIES No 50 ^A
PER SET \$9 00 SINGLE LETTER 40 CENTS



NONAME SERIES No 59 ^A
PER SET \$9 00 SINGLE LETTER 40 CENTS

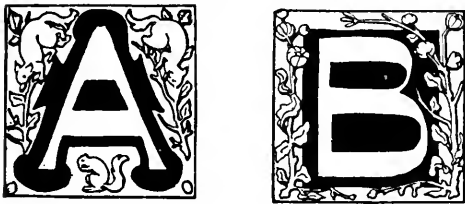

NONAME SERIES No 60 ^A
PER SET \$8 00 SINGLE LETTER 35 CENTS



MULTIPLE SERIES No 52 ^A
PER SET \$9 00 SINGLE LETTER 40 CENTS



MULTIPLE SERIES No 53 ^A
PER SET \$10 00 SINGLE LETTER 50 CENTS

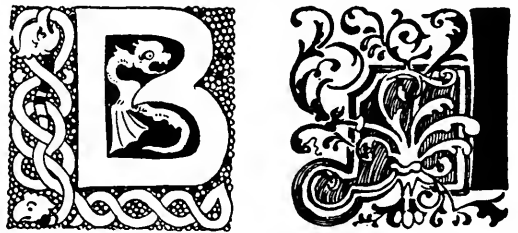

RENATE SERIES No 69 ^A
PER SET \$9 00 SINGLE LETTER 40 CENTS



RENATE SERIES No 70 ^A
PER SET \$8 00 SINGLE LETTER 35 CENTS



NEPTUNE SERIES No 66 ^A
PER SET \$8 00 SINGLE LETTER 35 CENTS



NEPTUNE SERIES No 65 ^A
PER SET \$9 00 SINGLE LETTER 40 CENTS

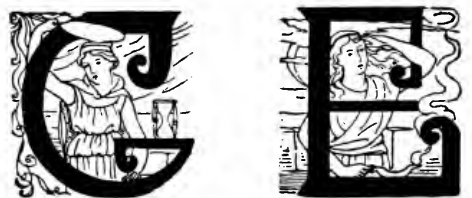

MISSAL SERIES No 58 ^A
SINGLE LETTER 40 CENTS



MISSAL SERIES No 57 ^A
SINGLE LETTER 35 CENTS



CAST INITIALS

36 POINT IPSEN INITIALS NO 2 ^A
PER SET \$4 00 SINGLE LETTER 30 CENTS



48 POINT IPSEN INITIALS NO 1 ^A
PER SET \$6 00 SINGLE LETTER 40 CENTS



72 POINT EMPIRE INITIALS ^F
PER FONT \$4 00 SINGLE LETTER 25 CENTS



48 POINT EMPIRE INITIALS ^F
PER FONT \$3 00 SINGLE LETTER 20 CENTS



54 POINT BRADLEY INITIALS ^C
3 A \$4 25
SINGLE LETTER 25 CENTS

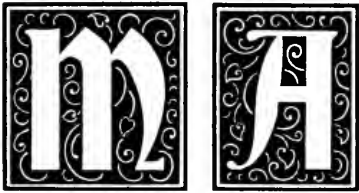

72 POINT JENSON INITIALS
No 79 ^A
SINGLE LETTER 60 CENTS



48 POINT SCHAEFFER OLD STYLE ^C
INITIALS 3 A \$4 00



42 POINT BRADLEY INITIALS ^C
3 A \$3 00
SINGLE LETTER 20 CENTS



36 POINT SCHAEFFER OLD STYLE ^C
INITIALS 4 A \$3 50



60 POINT TENDRIL INITIALS NO 1
PER SET \$8 00 ^A
SINGLE LETTER 50 CENTS



48 POINT JENSON INITIALS
No 80 ^A
SINGLE LETTER 50 CENTS

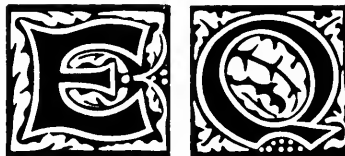

24 POINT SCHAEFFER OLD STYLE ^C
INITIALS 6 A \$2 50



15 POINT SCHAEFFER OLD STYLE ^C
INITIALS 6 A \$1 50



30 POINT JENSON INITIALS NO 82
SINGLE LETTER 25 CENTS ^A



48 POINT TENDRIL INITIALS NO 2
PER SET \$6 00 ^A
SINGLE LETTER 40 CENTS



CAST INITIALS

48 POINT MORTISED NO 2

3 A \$6 00

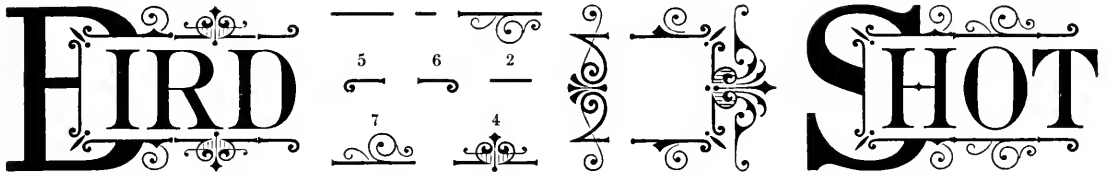

SERIES NO 1136

PER SET \$2 00

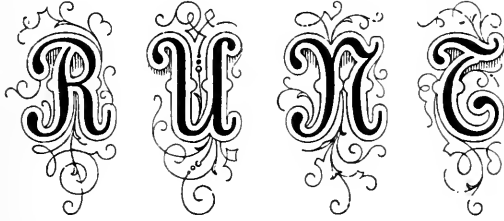

SERIES NO 1132

PER SET \$3 50

SINGLE LETTER 40 CENTS



SERIES NO 441

SINGLE LETTER WITH PENDANTS 40 CENTS
PER SET WITH PENDANTS AND SPACES \$7 00



SERIES NO 440

SINGLE LETTER WITH PENDANTS 40 CENTS
PER SET WITH PENDANTS \$5 00



48 POINT ART INITIALS
PER SET WITH ORNAMENTS \$3 00

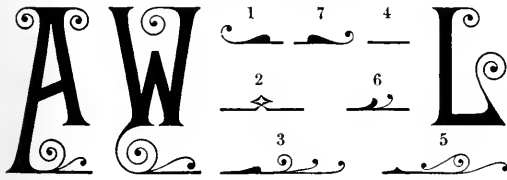

72 POINT ART INITIALS
PER SET WITH ORNAMENTS \$4 00

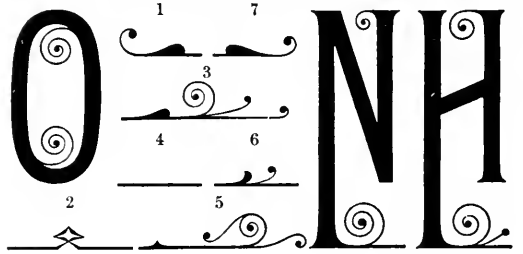

SERIES NO 1143

PER SET \$3 50

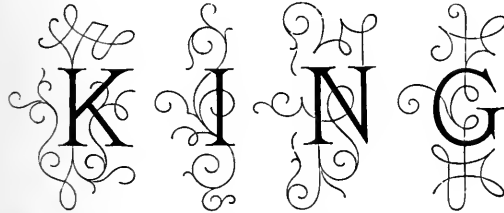

SERIES 1142

PER SET \$2 00



SERIES NO 1133
PER SET \$3 50 SINGLE LETTER 40 CENTS

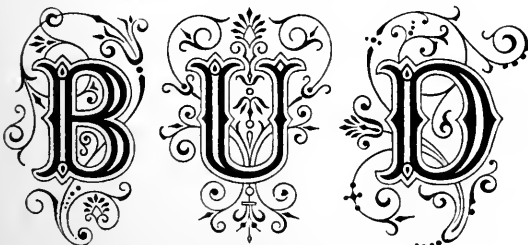

SERIES 1155
PER SET \$3 50 SINGLE LETTER 40 CENTS

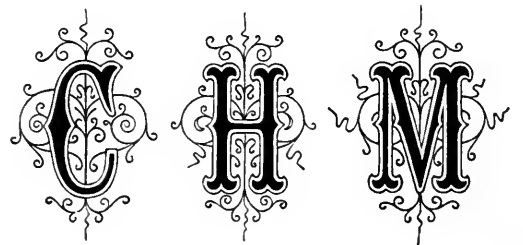

ELECTROTYPED NEWSPAPER HEADINGS

The following prices, subject to a Discount, are for XX Copper-face Electros on solid hard metal bases

| WIDTH OF HEADING | BODY—PICA MEASUREMENT | | | | | | |
|--------------------|-----------------------|--------|--------|--------|--------|--------|---------|
| | 4-LINE | 5-LINE | 6-LINE | 7-LINE | 8-LINE | 9-LINE | 10-LINE |
| 4 Column | \$2 00 | \$2 25 | \$2 50 | \$2 75 | \$3 00 | \$3 25 | \$3 50 |
| 5 " | 2 25 | 2 50 | 2 75 | 3 00 | 3 25 | 3 50 | 3 75 |
| 6 " | 2 50 | 2 75 | 3 00 | 3 25 | 3 50 | 3 75 | 4 00 |
| 7 " | 2 75 | 3 00 | 3 25 | 3 50 | 3 75 | 4 00 | 4 25 |
| 8 " | 3 00 | 3 25 | 3 50 | 3 75 | 4 00 | 4 25 | 4 50 |
| 9 " | 3 25 | 3 50 | 3 75 | 4 00 | 4 25 | 4 50 | 4 75 |

STYLE NO 104 D-E

FOUR-LINE PICA

ATCO DASH

STYLE NO 105 D-E-F

FOUR-LINE PICA

TRIBUNE

STYLE NO 106 D-E-F

SIX-LINE PICA

DISPATCH

STYLE NO 103 E

SIX-LINE PICA

THE SIGNAL

STYLE NO 108 D-E

SIX-LINE PICA

BLADE

ELECTROTYPED NEWSPAPER HEADINGS

For prices, see page 796

STYLE NO 170 E

FIVE-LINE PICA

KICKER

STYLE NO 151 A

SIX-LINE PICA

MAKER

STYLE NO 118 F

SIX-LINE PICA

HERALD

STYLE NO 123 D-E

SIX-LINE PICA

TRUTH

STYLE NO 36 D-E

FIVE-LINE PICA

COURIER

STYLE NO 121 D-E

FIVE-LINE PICA

ERIE BLADE

ELECTROTYPED NEWSPAPER HEADINGS

For prices, see page 796

STYLE NO 130

SIX-LINE PICA

CIRCUIT

STYLE NO 112

FIVE-LINE PICA

CITIZEN

STYLE NO 125

SIX-LINE PICA

SENTINEL

STYLE NO 172

FOUR-LINE PICA

COURIER

STYLE NO 115

FIVE-LINE PICA

MELBA SUN

STYLE NO 176

FOUR-LINE PICA

RECORD

ELECTROTYPED NEWSPAPER HEADINGS

For prices, see page 795

STYLE NO 173 E

FIVE-LINE PICA

HERALD

STYLE NO 127 F

SIX-LINE PICA

TRIBUNE

STYLE NO 177 F

SIX-LINE PICA

EXPRESS

STYLE NO 114 F

SIX-LINE PICA

COAL MINER

STYLE NO 178 F

SIX-LINE PICA

POST-DISPATCH

ELECTROTYPED NEWSPAPER HEADINGS

For prices, see page 796

STYLE NO 129 F

SIX-LINE PICA

Recorder

STYLE NO 120 D-E

FIVE-LINE PICA

Belton Post

STYLE NO 128 F

FIVE-LINE PICA

Eastonian

STYLE NO 124 F

SIX-LINE PICA

Farm Echo

STYLE NO 150 A

SIX-LINE PICA

Founder

ELECTROTYPED NEWSPAPER HEADINGS

For prices, see page 706

STYLE NO 171 ^ε

SIX-LINE PICA

THE DAILY

STYLE NO 131 ^F

FOUR-LINE PICA

CENSOR

STYLE NO 174

FIVE-LINE PICA

The Times

STYLE NO 119 ^ε

FOUR-LINE PICA

Pueblo Reporter

STYLE NO 175 ^ε

FIVE-LINE PICA

PRINTER

ELECTROTYPED NEWSPAPER HEADINGS

*For prices, see page 796*STYLE NO 145 ^Ε

SIX-LINE PICA

PioneerSTYLE NO 144 ^Ε

FIVE-LINE PICA

The JournalSTYLE NO 180 ^Ε

SEVEN-LINE PICA

AbendpostSTYLE NO 179 ^Ε

EIGHT-LINE PICA

RecorderSTYLE NO 136 ^F

FOUR-LINE PICA

Denver World

ELECTROTYPED NEWSPAPER HEADINGS

For prices, see page 795

STYLE NO 139 D-E

SIX-LINE PICA

The Western

STYLE NO 147 C

FIVE-LINE PICA

Volkswacht

STYLE NO 137 F

SIX-LINE PICA

Advertiser

STYLE NO 148 C

FOUR-LINE PICA

The Guardian

STYLE NO 135 D-E-F

FIVE-LINE PICA

Raleigh Leader

ELECTROTYPED NEWSPAPER HEADINGS

For prices, see page 790

STYLE NO 141 D-E

SEVEN-LINE PICA

Enterprise

STYLE NO 142 E

SEVEN-LINE PICA

Reporter

STYLE NO 143 D-E

EIGHT-LINE PICA

The News

STYLE NO 140 E

SIX-LINE PICA

The Press

STYLE NO 138 D-F

FIVE-LINE PICA

Salem Item

ELECTROTYPED NEWSPAPER HEADINGS

For prices, see page 796

STYLE NO 182

€

EIGHT-LINE PICA

Signal

STYLE NO 183

€

SEVEN-LINE PICA

The Sun

STYLE NO 181

€

EIGHT-LINE PICA

Anzeiger

STYLE NO 184

€

EIGHT-LINE PICA

The Item

ATTRACTIVE HEADINGS

1 MUST USE THE FENDER

2 All Trolley Cars Must be Supplied
With Proper Safeguards
Immediately

3 COMES UNDER THE NEW LAW

4 Street Committee and the Trolley Com-
pany Take Opposite Views of
the Question

5 The Chairman of the Committee on
Streets of the City Council raised an
important question at a meeting of that
committee last night. He had been ab-
sent from several preceding meetings, at
one of which the Railway Company
was given the privilege of attaching a

6 NEW CHANCELLOR ON THE BENCH

7 His First Orders Stirred Up Dilatory Lawyers.
Found Them Unprepared

8 Trenton, May 15.—The Chancellor
revived a dead rule of the court to-
day which requires lawyers to be

1 FIERCE FLAMES

2 Scores of Spectators See Girls Jump
From the Fifth-Story Windows
or Slide Down Ropes

3 TWO KILLED - FIVE HURT

4 Flames Fed on Flimsy Fabrics Make a Beacon
of Fire Seen Fifty Miles Away Ten
Minutes After the Start

5 ORIGIN OF THE FIRE YET A MYSTERY

6 For the second time within two months
flames threatened last night to wipe out
the entire millinery district centering at
Eighth and Arch Streets. Three build-
ings were completely destroyed and many
others damaged, causing a loss of more
than half a million dollars. One woman
jumped from the fifth story of a burning

7 HEAVY BAIL PROCURED

8 Iron Worker Who Killed Fellow Work-
man is Released on Bail

9 Norristown, Feb. 23.—The man who was com-
mitted to jail several days ago on the charge
of causing the death of his fellow-workman,

STYLES OF TYPE USED IN ABOVE HEADINGS

| | | | |
|---|-----------------|---|-----------------|
| 1—24 Point Philadelphia Lining Gothic No. 624 | 16A Caps \$2.25 | 1—30 Point Philadelphia Lining Gothic No. 630 | 12A Caps \$2.80 |
| 2—12 Point Philadelphia Lining Gothic No. 612 | 35A 52A \$3.75 | 2—10 Point Philadelphia Lining Gothic No. 610 | 45A 60A \$3.50 |
| 3—12 Point Philadelphia Lining Gothic No. 612 | 35A Caps \$1.90 | 3—18 Point Philadelphia Lining Gothic No. 618 | 22A Caps \$2.25 |
| 4—6 Point Lining Gothic No. 417 | 60A 70A \$4.00 | 4—8 Point Philadelphia Lining Gothic No. 608 | 52A 70A \$3.25 |
| 5—8 Point No. 61 | | 5—8 Point Philadelphia Lining Gothic No. 608 | 52A Caps \$1.75 |
| 6—10 Point Philadelphia Lining Gothic No. 610 | 45A Caps \$1.90 | 6—7 Point No. 61 | |
| 7—8 Point Philadelphia Lining Gothic No. 608 | 52A 70A \$3.25 | 7—18 Point Philadelphia Lining Gothic No. 618 | 22A Caps \$2.25 |
| 8—9 Point No. 61 | | 8—10 Point Philadelphia Lining Gothic No. 610 | 45A 60A \$3.50 |
| | | 9—6 Point No. 61 | |

ATTRACTIVE HEADINGS

1 MURDER IN A SHANTY

**2 FISHERMAN TRIES TO KILL—DRINK-CRAZED SLAYER
WIELDS A KNIFE—HIS FRIENDS FIGHT FOR LIFE**

3 One Man Dead and Two Hurt

**4 THE MURDERER THEN SURRENDERS TO THE
POLICE WITHOUT A STRUGGLE**

5 Imprisoned in a fisherman's "shack" at the foot of 54th street with a demented fisherman five of his companions were cut and slashed with a fish knife, and only after a fierce struggle was he overcome. The wild man, whose name he would not reveal, was engaged in cleaning a mess of fish to cook for the supper of himself and friends, when without a warning he bounded over the table, behind which he was at work, and plunged the fish knife deep into the neck of the first man he reached. The other members of the party were compelled to overcome

6 MAKING SAUSAGES OF HORSEFLESH

**7 A Factory Alleged to Have Been Located in the
Town of Milwaukee**

8 RAILROAD INTERESTS

9 NINETY SYSTEMS REPRESENTED

**10 American Railway Association Meeting the
Largest in its History.**

11 The American Railway Association held the largest meeting in its history at St. Louis last week. Delegates from ninety systems were pre-

DUTCH IS TO CARRY

PASSENGERS IN THE PARK

**Lincoln Park Pachyderm Trained
to Entertain Visitors**

THREE CAMELS ALSO TO BE USED

STORY OF SUNDAY WEATHER

"Dutch," the big elephant in Lincoln Park, received her Sunday callers in her stays yesterday—four long planks securely roped to one another and bound about her ample waist to protect her delicate skin from abrasion by the rough corners of the howda. She will be housed in her old summer quarters, which have been moved to a point directly west of the ani-

DAY IN WALL STREET

SUGAR THE PRINCIPAL FEATURE

**Chicago Operator Said to Have Been Pinched
in the Advance--Railway Stronger**

New York, May 5—The market was very quiet 10 to-day owing to the unsettled condition which exists throughout the labor world. Sugar was

STYLES OF TYPE USED IN ABOVE HEADINGS

- 1—18 Point Quentell 10A Caps \$1.60
- 2—6 Point Quentell 24A Caps \$1.10
- 3—12 Point Quentell 16A 20A \$3.00
- 4—8 Point Quentell 22A Caps \$1.30
- 5—5½ Point No. 57
- 6—8 Point Quentell 22A Caps \$1.30
- 7—6 Point Quentell 24A 36A \$2.25
- 8—12 Point Condensed Title No. 124 18A Caps \$1.40
- 9—6 Point Latin Antique No. 120 24A Caps \$1.15
- 10—6 Point Caxton Bold 24A 48A \$2.60
- 11—6 Point No. 57

- 1—36 Point Binner Gothic 10A Caps \$3.15
- 2—6 Point No. 5 Interchangeable Gothic 36A \$1.70
- 3—8 Point Ronaldson Clarendon 30A 60A \$3.45
- 4—24 Point Binner Gothic 14A Caps \$2.20
- 5—6 Point Howland 30A Caps \$1.25
- 6—8 Point No. 65
- 7—14 Point Condensed Title No. 125 18A Caps \$1.45
- 8—6 Point Latin Antique No. 120 24A Caps \$1.15
- 9—6 Point Howland 30A 50A \$2.25
- 10—7 Point No. 65

ATTRACTIVE HEADINGS

MOSCOW FESTIVAL

2 Czar Inaugurates a Three-Day Celebration and then Holds a State Levee at the Kremlin

A LARGE GATHERING AT EASTER SERVICE

4 Attended by 250,000 People—The City is Ablaze with Electric and Gas Illuminations

5 Moscow, April 2.—Such a night of pomp and ceremony as that which began just before midnight of Easter Eve has not been known in Moscow since 1850

SEE MICHIGAN IN A MIRAGE

7 Illinois Central Passengers Think Lake Has Dwindled Suddenly--Sand Hills Glisten in the Sun

TEN KILLED IN EXPLOSION

9 A Powder Magazine in China Blows Up Destroying 244 Houses

10 Hong Kong, April 26.—The Imperial Powder Magazine, wherein was stored the new consignment of high explosives, was blown up this morning destroying two hundred and forty-four houses, and causing the loss of life

HOUSE BANS MAIL TUBES

2 CUTS OUT ENTIRE APPROPRIATION FOR SUP-
PORT AND EXTENSION

BACKERS STILL HOPEFUL

4 They Think Senate Will Help the Measure
Through--Charges of Corruption
are Made

5 Washington, April 25.—Two prominent Representatives, one a staunch Republican and the other a consistent Democrat, were responsible this afternoon for the defeat of the bill introduced several weeks ago looking to the extension of mail-tube service to all first-class post-offices. The bill provided, among other things, for special pumping apparatus strong enough to force the excuse

LOCAL STOCK MARKET**POLLY L PREFERRED ON THE DOWN GRADE**

8 Diamond Match Active and Scores a Decided
Advance—Standard Oil is Firm

9 New York, April 26.—The market was unusually quiet to-day owing to the unsettled conditions which prevail all over

STYLES OF TYPE USED IN ABOVE HEADINGS

1—36 Point Gothic Extra Condensed No. 122 6A Caps \$2.20
2—8 Point Ionic No. 122 24A 48a \$2.60
3—10 Point Gothic Condensed No. 122 20A Caps \$0.80
4—6 Point Ionic No. 122 24A 48a \$2.30
5—8 Point No. 57
6—18 Point Latin Condensed No. 150 20A Caps \$1.75
7—6 Point Boldface No. 120 24A 48a \$2.30
8—12 Point Gothic Condensed No. 124 18A Caps \$1.25
9—6 Point Antique No. 125 24A 48a \$2.30
10—7 Point No. 67

1—24 Point Arlington 8A Caps \$2.30
2—6 Point Howland 30A Caps \$1.25
3—12 Point Arlington 16A Caps \$1.70
4—10 Point Arlington 20A 26a \$2.75
5—7 Point No. 57
6—12 Point Runic Condensed No. 122 18A \$1.35
7—6 Point Howland 30A Caps \$1.25
8—6 Point Old Style Antique No. 120 24A 48a \$2.00
9—8 Point No. 67

ATTRACTIVE HEADINGS

1 Realty in a Tangle

2 PROPERTY ON PHILIPPINE ISLANDS

**3 Lands Both in Manila and Elsewhere Claimed
by Orders**

4 PROBLEM FOR COMMISSION

**5 Tax Sales Imminent---Will Have to Oust
Many of the Present Holders on
Squatter Claims**

**6 Manila, April 2.—One of the first and perhaps
the most important duties of the Commission,
upon taking charge of affairs in the Philippine
Islands, will be to appoint a court to determine
the possession of large tracts of the best land and
town property which had been usurped by the
Spanish padres without the formality of a grant.
When the American forces appeared off Man-
ila these men saw the probability of Spain's loss
of possession and therefore concluded to be**

7 WANT TO EXTEND TRADE

8 MANUFACTURERS AT A FEAST

**9 Chinese Minister and Others of Prom-
inence Tell How Americans Can
Capture Oriental Markets**

**10 Washington, April 24.—The members of
the Board of Trade held their annual ban-
quet here last evening. Speeches bearing**

1 GIRL DROPS DOWN

2 From the Brooklyn Bridge

3 WILL LIVE AFTER PLUNGE

**4 Marie Rosalie Dinse Tries Suicide—
Had Lost Her Money in a Board-
ing-House Venture**

**5 New York, May 1.—Marie Rosalie Dinse is the
second woman who has attempted suicide by
dropping from Brooklyn bridge into the black
water 125 feet below. When picked up it was
supposed that her terrible fall had without doubt
killed her, but she was alive, though unconscious.
After a few minutes' work she was restored to
consciousness when she expressed sorrow that her
effort had fallen short of her intention, as she was
in earnest in her desire to end life. She was
taken to the hospital, and it is thought as soon as
she has recovered from the effects she will be**

6 TOWARD IMPROVING RIVER

7 WORK WILL BE PUSHED RAPIDLY

**8 Sanitary Trustees File Papers of Condemna-
tion of Certain Property**

**9 Contracts were awarded yesterday to the United
Dredging Company of New York for the removal
of the obstructions which spoil the harbor of this**

STYLES OF TYPE USED IN ABOVE HEADINGS

- 1—24 Point Schœffer Old Style 12A 18a \$4.00
- 2—8 Point Schœffer Old Style 25A Caps \$0.95
- 3—8 Point Schœffer Old Style 25A 50a \$2.00
- 4—12 Point Schœffer Old Style 20A Caps \$1.15
- 5—10 Point Schœffer Old Style 25A 50a \$2.25
- 6—6 Point No. 53
- 7—14 Point Gothic Condensed No. 123 18A Caps \$1.45
- 8—8 Point Old Style Antique No. 120 20A Caps \$1.00
- 9—6 Point Caxton Bold 24A 48a \$2.60
- 10—7 Point No. 53

- 1—42 Point Gothic Extra Condensed No. 150 6A Caps \$2.35
- 2—8 Point Ronaldson Clarendon 30A 60a \$3.45
- 3—12 Point Gothic Condensed No. 124 18A Caps \$1.25
- 4—8 Point Old Style Antique No. 120 20A 40a \$2.10
- 5—6 Point No. 67
- 6—20 Point Extra Condensed No. 123 10A Caps \$1.45
- 7—6 Point Latin Antique No. 120 24A Caps \$1.15
- 8—6 Point Old Style Antique No. 120 24A 48a \$2.00
- 9—6 Point No. 65

NEWSPAPER SUB-HEADINGS

Order by name, No and Initial

TRIMMED TO 13 EMS PICA

PRICE 50 CENTS EACH

NO 26E

DENVER RECORD.

NO 23E

MORNING WORLD.

NO 27E

DAILY TRUTH.

NO 21E

RACINE REPUBLICAN.

NO 22E

MORNING JOURNAL.

NO 28½E

BICYCLE REVIEW.

NO 6E

DAILY TRUTH.

NO 9F

DAILY TRANSCRIPT.

NO 13F

ARBEITER ZEITUNG NEWS.

NO 10F

THE MINING JOURNAL.

NO 3F

THE REPUBLICAN.

NO 5F

DAILY REPUBLICAN.

NO 1F

DAILY RECORD.

NO 4E

THE DETROIT ARGUS.

NO 5E

St. Louis Review.

NO 13E

CHICAGO DISPATCH.

NO 7E

THE MADISON PRESS.

NO 10E

The Sunday Democrat.

NO 12E

HOUSTON JOURNAL.

NO 11E

Ontario County Sunday Visitor.

NO 33E

Evening Recorder.

NO 32E

The Illinois Independent.

NO 1E

Early Morning Telegraph.

NO 14E

The Weekly Reporter.

NO 53E

The Duluth Signal.

NO 32½E

The Daily Argus.

NO 38E

Dakota Signal.

NO 34E

New York Eagle.

NO 8E

Des Moines Transcript.

NO 9E

The Kansas City Times.

BRASS SUB-HEADS AND DATE LINES

SUB-HEADS, \$1 50 EACH

DATE LINES, 10 CENTS PER LETTER

MADE ON SINGLE BASE OR IN PIECES, AS DESIRED

BRASS NO 609

WEEKLY COURIER

BRASS NO 643

Staten Island Star

BRASS NO 258

ALBANY TIMES

BRASS NO 476

New Jersey Free Press

BRASS NO 586

Boston Evening World

BRASS NO 493

FLUSHING JOURNAL

BRASS NO 257

NEW YORK SUN

BRASS NO 538

BROOKLYN CITIZEN

BRASS NO 255

NEW YORK HERALD, SATURDAY, SEPTEMBER 25, 1900. VOL. VII.

BRASS NO 608

BOSTON JOURNAL, WEDNESDAY, MAY 1, 1900. 14 PAGES

BRASS NO 256

STATEN ISLAND MORNING TIMES, WEDNESDAY, APRIL 17, 1900

BRASS NO 257

TROY WEEKLY ADVERTISER, TUESDAY, JULY 1, 1900

BRASS NEWSPAPER HEADINGS

ONE WORD, \$4 00 TWO WORDS, \$6 00 EACH ADDITIONAL WORD, \$1 50

Made on single base or in pieces, as desired. Specimens of other styles sent upon request.

BRASS No 650

RECORD

BRASS No 651

HOURLY

BRASS No 652

BRIGHT

BRASS No 662

Advocate

BRASS No 653

SHRINE

BRASS NEWSPAPER HEADINGS

ONE WORD, \$4 00 TWO WORDS, \$6 00 EACH ADDITIONAL WORD, \$1 50

Made on single base or in pieces, as desired. Specimens of other styles sent upon request.

BRASS No 579

LEDGER

BRASS No 658

RUMOR

BRASS No 659

TIMES

BRASS No 654

GLEANER

BRASS No 655

RECORDS

BRASS NEWSPAPER HEADINGS

ONE WORD, \$4 00 TWO WORDS, \$6 00 EACH ADDITIONAL WORD, \$1 50

Made on single base or in pieces, as desired. Specimens of other styles sent upon request.

BRASS No 656

MONTH

BRASS No 578

THE SUN

BRASS No 660

Free Press

BRASS No 661

HERALD

BRASS No 657

Courier

COMMERCIAL LOGOTYPES

| | | | | | |
|--|---------------------------------|---------------------------------|--|--------------------------------------|--------------------------------|
| No. 501C. 10 cts. <i>190</i> | No. 502C. 10 cts. <i>190</i> | No. 503C. 10 cts. <i>190</i> | No. 504C. 10 cts. <i>190</i> | No. 508C. 10 cts. <i>Dr</i> | No. 516C. 10 cts. <i>Cr</i> |
| No. 509C. 10 cts. <i>To</i> | No. 512C. 10 cts. <i>Mc</i> | No. 513C. 10 cts. <i>M</i> | No. 514C. 10 cts. <i>No.</i> | No. 515C. 10 cts. <i>No.</i> | No. 511C. 10 cts. <i>Mc</i> |
| No. 546C. 15 cts. <i>Mc</i> | No. 547C. 15 cts. <i>M</i> | No. 548C. 15 cts. <i>No.</i> | No. 549C. 15 cts. <i>No.</i> | No. 566C. 30 cts. <i>Received</i> | |
| No. 544C. 15 cts. <i>Dr</i> | No. 545C. 15 cts. <i>To</i> | No. 550C. 15 cts. <i>Cr</i> | No. 569C. 25 cts. <i>Bought of.</i> | | |
| <i>Buffalo Dollars and charge to account of</i> | | | | | |
| <i>Solid body Electros, set in 28 Point Spencerian Script No. 2, as in line above, furnished at 25 cents per lineal inch</i> | | | | | |
| <i>Bought of Dollars New York</i> | | | | | |
| <i>Solid body Electros, set in 40 Point Spencerian Script No. 2, as in line above, furnished at 30 cents per lineal inch</i> | | | | | |

BILLHEAD LOGOTYPES

Cast in a type mould

| | | | | |
|---|--|---|---|--|
| No. 106C. 40 cts.  | No. 107C. 40 cts.  | No. 103C. 40 cts.  | | |
| No. 108C. 40 cts.  | No. 97C. 40 cts.  | No. 94C. 40 cts.  | No. 105C. 40 cts.  | |
| No. 104C. 40 cts.  | No. 98C. 35 cts.  | No. 92C. 30 cts.  | No. 99C. 35 cts.  | No. 95C. 40 cts.  |

ELECTROTYPED DATE LINES

PRICES ARE FOR ANY CITY, AS PER STYLES SHOWN. LENGTH OF DOTTED LINE, ABOUT 9 PICAS.

| | | | | | |
|-----------------------|-----------------------------|-----|-----------------------|------------------------------|-----|
| STYLE NO 6F 75 CENTS | <i>Detroit,</i> | 190 | STYLE NO 22F 75 CENTS | <i>Carthage, Mo.,</i> | 190 |
| STYLE NO 9F 75 CENTS | <i>Omaha, Neb.,</i> | 190 | STYLE NO 15F 75 CENTS | <i>Lincoln, Neb.,</i> | 190 |
| STYLE NO 1F 75 CENTS | <i>Dallas, Tex.,</i> | 190 | STYLE NO 16F 60 CENTS | <i>St. Louis, Mo.,</i> | 190 |
| STYLE NO 11F 60 CENTS | <i>Portland, Ore.,</i> | 190 | STYLE NO 20F 60 CENTS | <i>Boise City, Idaho,</i> | 190 |
| STYLE NO 7F 60 CENTS | <i>Chester, Tex.,</i> | 190 | STYLE NO 17F 60 CENTS | <i>Minneapolis, Minn.,</i> | 190 |
| STYLE NO 3F 60 CENTS | <i>Denver, Colo.,</i> | 190 | STYLE NO 21F 60 CENTS | <i>Louisville, Ky.,</i> | 190 |
| STYLE NO 13F 50 CENTS | <i>Jefferson City, Mo.,</i> | 190 | STYLE NO 18F 50 CENTS | <i>Des Moines, Iowa,</i> | 190 |
| STYLE NO 5F 50 CENTS | <i>Kansas City, Mo.,</i> | 190 | STYLE NO 14F 50 CENTS | <i>Salt Lake City, Utah,</i> | 190 |

ELECTROTYPED DATE LINES

PRICES ARE FOR ANY CITY AS PER STYLES BELOW. LENGTH OF DOTTED LINE, ABOUT 9 PICAS.

| | | | | | |
|-----------------------|--------------------|-----|-----------------------|-----------------------|-----|
| STYLE NO 25F 60 CENTS | BOISE CITY, IDAHO, | 190 | STYLE NO 34F 60 CENTS | San Francisco, Cal., | 190 |
| STYLE NO 26F 60 CENTS | Sacramento, Cal., | 190 | STYLE NO 35F 60 CENTS | Texarkana, Ark., | 190 |
| STYLE NO 27F 60 CENTS | TOPEKA, KAN., | 190 | STYLE NO 36F 75 CENTS | Chino, Cal., | 190 |
| STYLE NO 28F 60 CENTS | ST. PAUL, MINN., | 190 | STYLE NO 37F 50 CENTS | Salt Lake City, Utah, | 190 |
| STYLE NO 29F 60 CENTS | Salem, Oregon, | 190 | STYLE NO 38F 60 CENTS | Chicago, Ill., | 190 |
| STYLE NO 30F 60 CENTS | St. Paul, Minn., | 190 | STYLE NO 39F 50 CENTS | St. Joseph, Mo., | 190 |
| STYLE NO 31F 60 CENTS | Hartford, Ind., | 190 | STYLE NO 40F 60 CENTS | Corinth, Miss., | 190 |
| STYLE NO 32F 60 CENTS | Helena, Montana, | 190 | STYLE NO 41F 60 CENTS | St. Louis, | 190 |
| STYLE NO 33F 60 CENTS | New Orleans, | 190 | | | |

CHECK BLANKS

In ordering be careful to add the words "Check Blank" to the No. wanted.

No. 295C. 40 cts.



No. 296C. 40 cts.

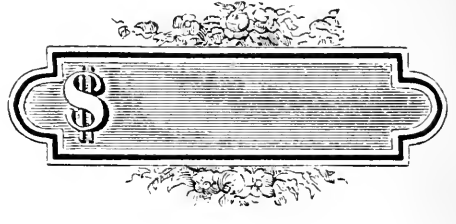

No. 269C. 30 cts.

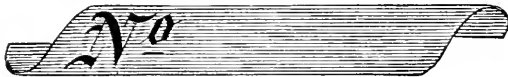

No. 270C. 30 cts.

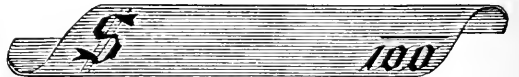

No. 301C. 35 cts.



No. 302C. 35 cts.

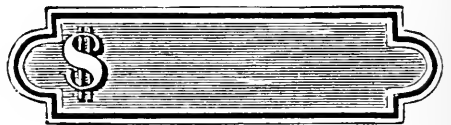

No. 304C. 40 cts.



No. 291C. 35 cts.

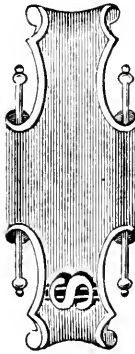

No. 305C. 40 cts.

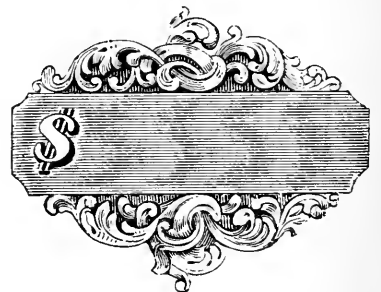

No. 279C. 30 cts.

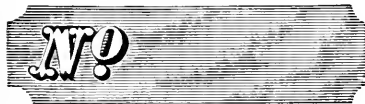

No. 280C. 30 cts.

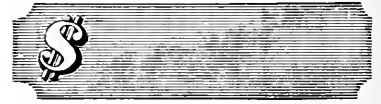

No. 311C. 50 cts.



No. 290C. 35 cts.

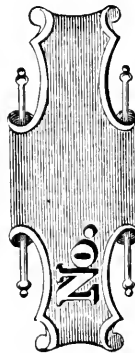

No. 312C. 50 cts.



No. 293C. 35 cts.

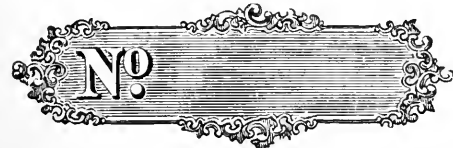

No. 292C. 35 cts.

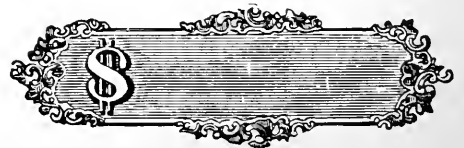

Cast and Electrotyped

✦ CUTS ✦

Emblems of the
UNITED STATES

STATE SEALS

Society Emblems

BUSINESS CUTS



BOWLERS A

PER FONT \$1 75

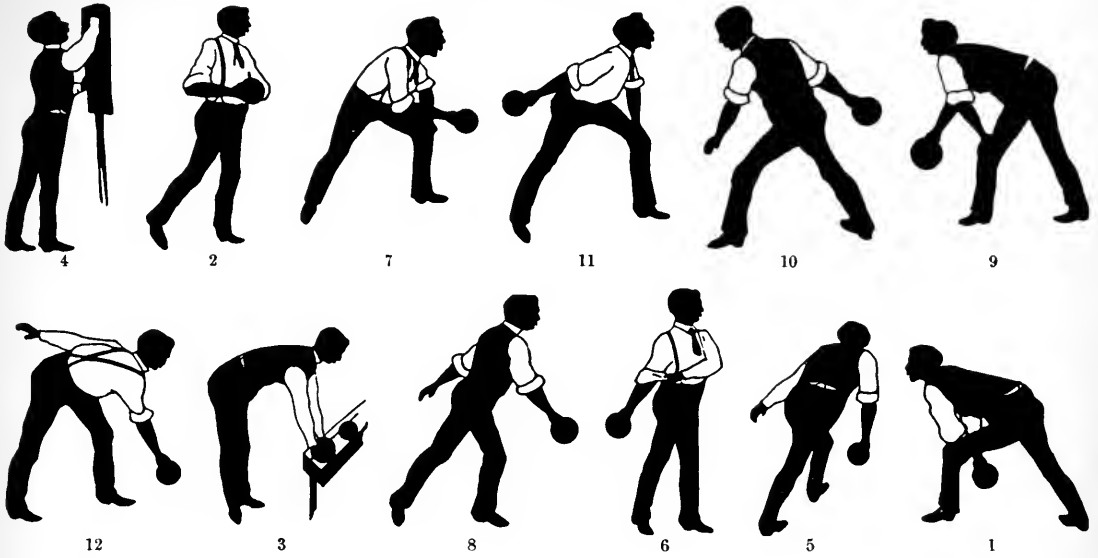

ARMY AND NAVY No 1 E

PER FONT \$2 00

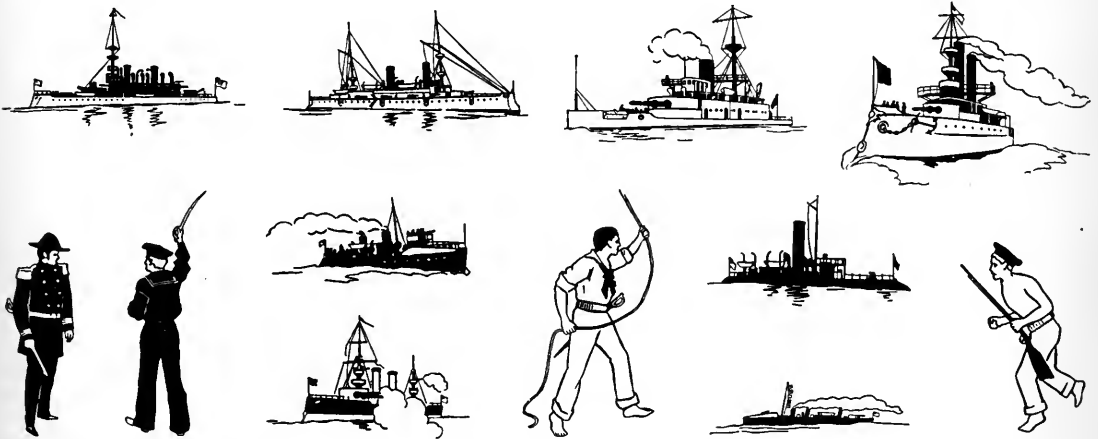

ARMY AND NAVY No 2

PER FONT \$2 00

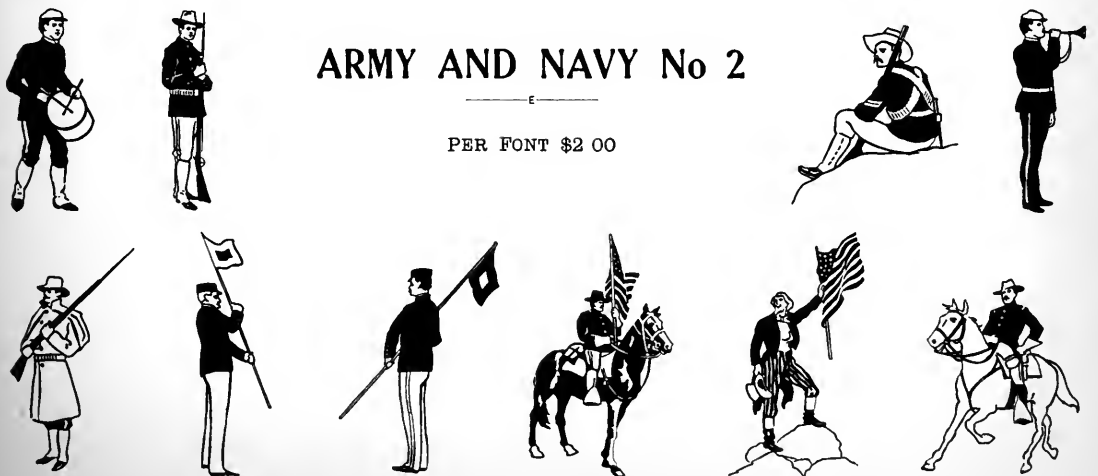

DELMONICO CHEFS AND WAITERS

PER FONT \$1 50



9 10



4 2 7 8



1 5 6 3

HOBOS

PER FONT \$1 50



8 7



4 6 3 5



1 9 10 2

KLONDIKERS

CARD FONT \$2 00
JOB FONT \$3 50



8



10



5



3 1 9



7 2 4 6

BASEBALL

Series No 1

PER FONT \$1 50

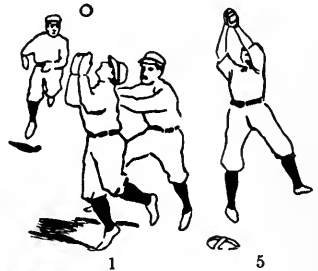

1 5



8 6 10



3 2 9 4 7

PICK-UPS ^A

PER FONT \$1 75

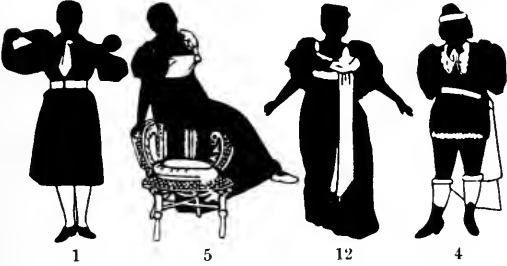
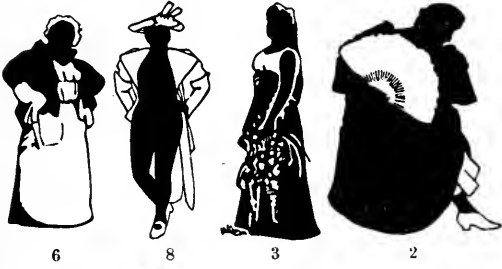
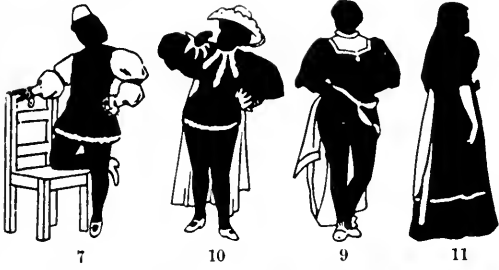

COPPERS ^F

PER FONT \$1 50



DRUGGISTS ^F

PER FONT \$1 50

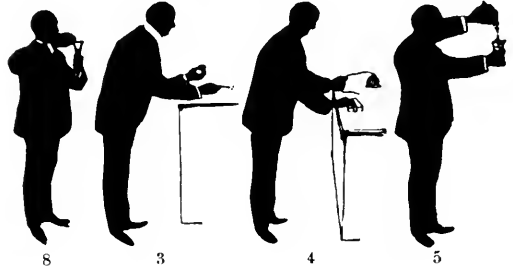
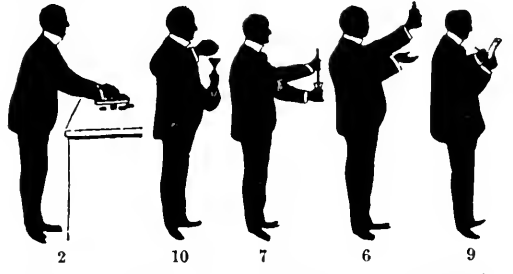

SILHOUETTES ^A

PER FONT \$1 75

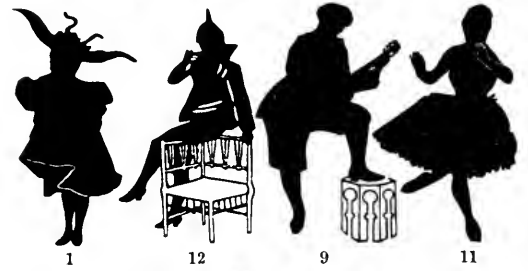

SPEAKERS ^E

LARGE FONT \$2 50
SMALL FONT 1 50

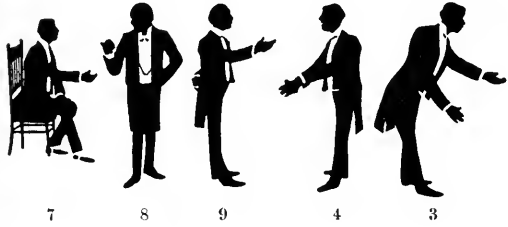
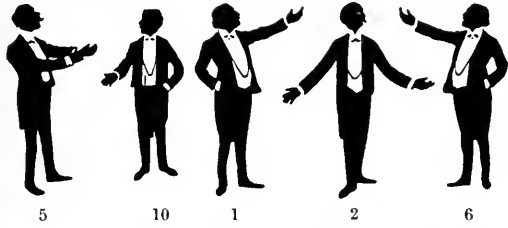

***CAMPAIGNERS** ^A PER FONT \$1 75

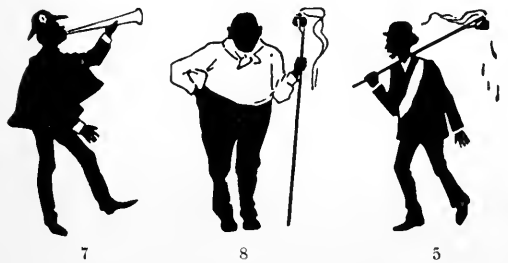
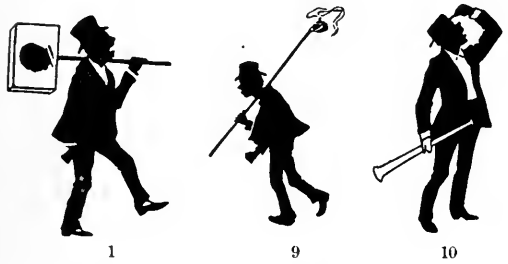
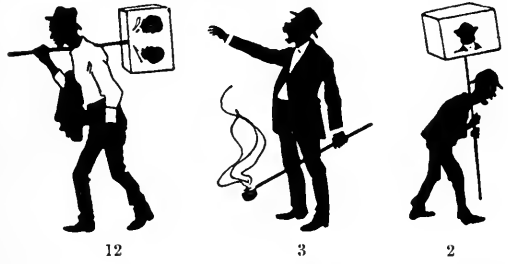

LISTENERS ^E

PER FONT \$1 50

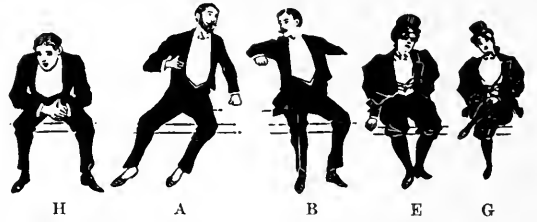

BALLET DANCERS ^F FONT \$2 00

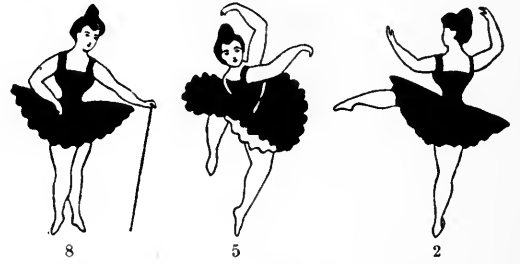

* See Large Campaigners, page 924

LARGE LADY SPEAKERS

PER FONT

\$2 00



SMALL LADY SPEAKERS

PER FONT

\$1 25



SHOPPERS

PER FONT \$1 50

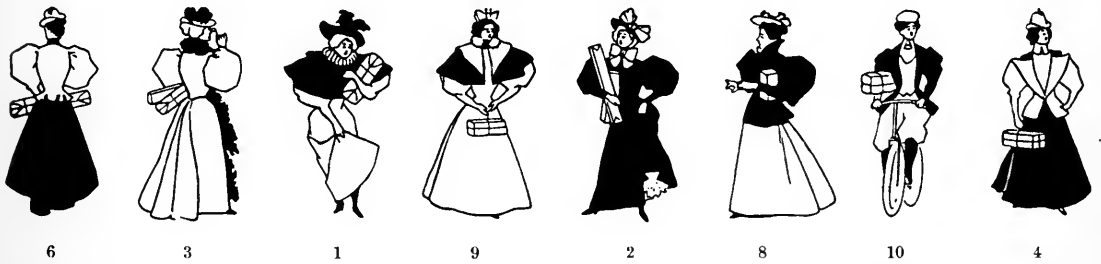

DOMESTICS

PER FONT

\$1 50



LARGE SCORCHERS

PER FONT

— 8 —

\$2 50



3



4



10



6



8



5



7

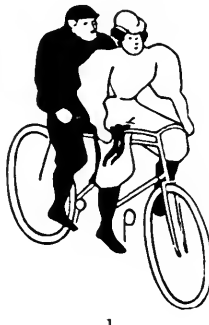

1



2



9

SMALL SCORCHERS

PER FONT

— 8 —

\$1 50



15



18



11



19



12



14



16



20



17



13

RIGS AND TRAPS

PER FONT

— 8 —

\$1 50



5



7



1



2



8



6



3



4

ROUNDERS ^ε

PER FONT \$1 50



INK SPOTS ^ε

PER FONT \$1 25



1

2



6

4



SLOCUM SEALS ^ε

PER FONT \$1 50

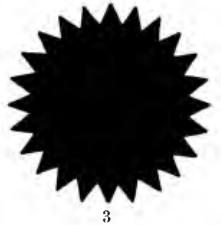
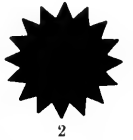
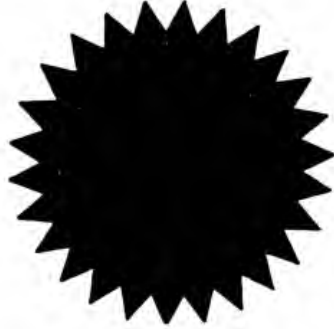

ATHLETES ^ε

PER FONT \$1 50



KATE GREENAWAY MIGNONNETTES

All cast in type mould



44. 30c.



13. 30c.



34. 25c.



1. 25c.



53. 25c.



28. 25c.



43. 30c.



14. 30c.



45. 30c.



16. 30c.



51. 25c.



11. 25c.



38. 25c.



12. 25c.



54. 25c.



29. 25c.



52. 25c.



20. 25c.



46. 30c.



15. 30c.



48. 30c.



19. 30c.



35. 25c.



7. 25c.



56. 25c.



30. 25c.

KATE GREENAWAY MIGNONNETTES

All cast in type mould



58. 25c.



27. 25c.



32. 25c.



6. 25c.



55. 25c.



22. 25c.



57. 25c.



10. 25c.



21. 25c.



50. 25c.



41. 25c.



23. 25c.



40. 25c.



9. 25c.



36. 25c.



3. 25c.



31. 25c.



5. 25c.



37. 25c.



2. 25c.



60. 25c.



24. 25c.



39. 25c.



26. 25c.



33. 25c.



8. 25c.



47. 30c.



17. 30c.



49. 30c.



18. 30c.



25. 25c.



59. 25c.



42. 25c.



4. 25c.

STATE SEALS

Designed and cut on wood by the American Type Founders Company. Each Seal is re-engraved when any change occurs, and Seals of all new States are added.

Border No. 2751C. (Center mortised to suit the Seal of any State.) \$1.50. With Seal of any State, \$2.00



No. 2776C. 75 cts. [Ohio]



No. 2240C. \$1.00 [Illinois]



No. 2779C. 75 cts. [Illinois]



No. 2785C. 75 cts. [California]



No. 2778C. 75 cts. [Indiana]



No. 2780C. 75 cts. [Missouri]



No. 2241C. \$1.00 [Missouri]

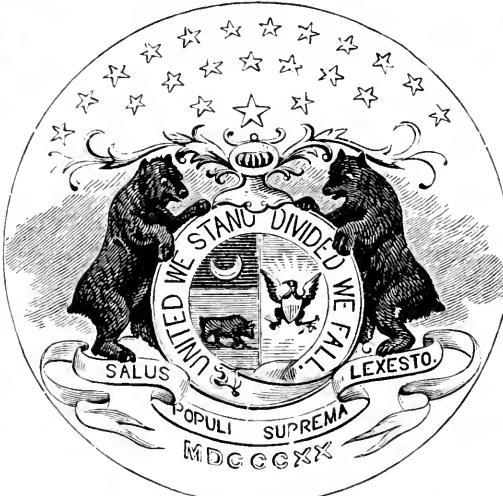

No. 2775C. 75 cts. [Kentucky]



We have Seals for all States, uniform with the styles shown on this and the following page, at same prices

No. 3131C. \$1.00 [Minnesota]



No. 3128C. \$1.00 [Missouri]

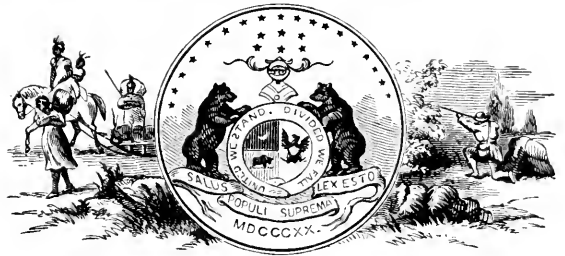

No. 3121C. \$1.00 [Arkansas]

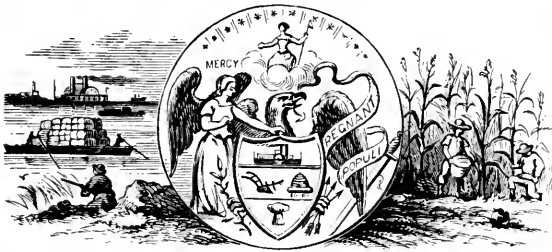

No. 3123C. \$1.00 [Kentucky]

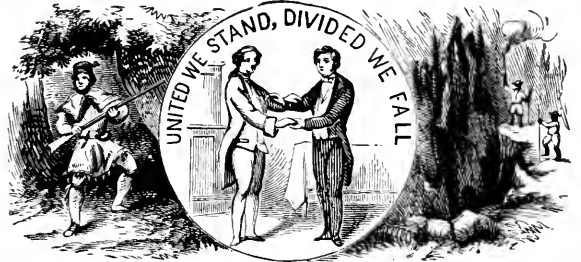

No. 3140C. \$1.00 [Nebraska]



No. 3130C. \$1.00 [Wisconsin]

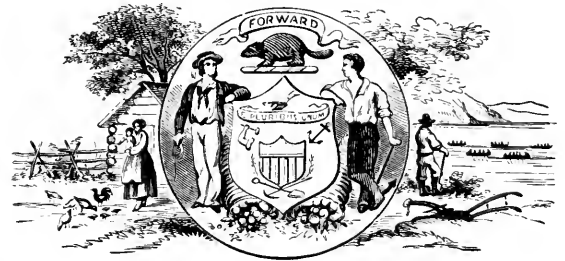

No. 3127C. \$1.00 [Illinois]

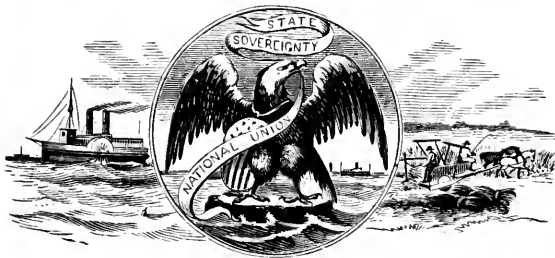

No. 3138C. \$1.00 [Colorado]

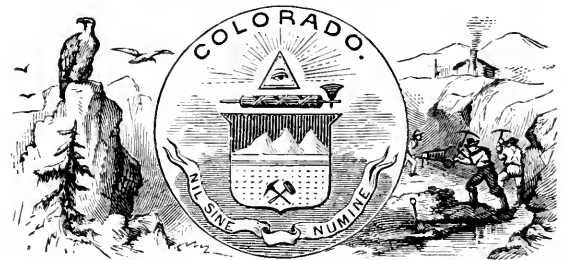

No. 3135C. \$1.00 [Oregon]

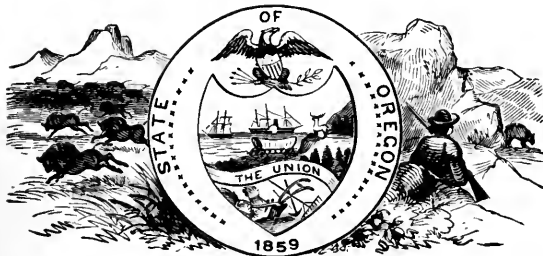

No. 3137C. \$1.00 [Kansas]

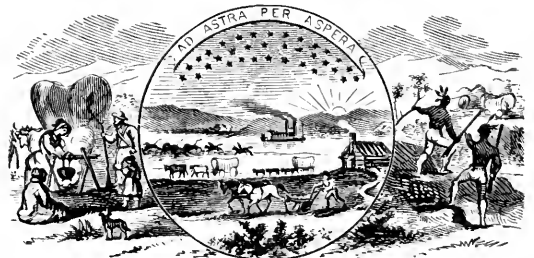

We have Seals for all States, uniform with the styles shown on this and the preceding page, at same prices

UNITED STATES EMBLEMS

Designed and engraved on wood by the American Type Founders Company

No. 2442C. 25 cts.



No. 3929C. Mortised. \$1.25

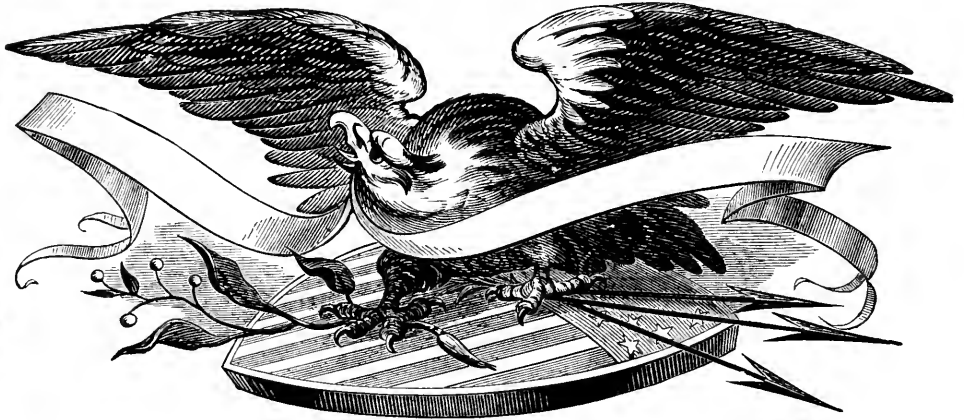

No. 857E. 25 cts.



EAGLES FOR POSTERS

We have a number of mortised Eagle cuts, same style, but larger than No. 3929C. All are cut with the same degree of excellence.

- No. 2875C, 18x7 1/2 inches; three mortises for 48-point letter . . \$10.00
- No. 2874C, 11x5 1/4 inches; two mortises for 36-point letter . . . 4.50
- No. 2873C, 8x4 inches; two mortises for 24-point letter . . . 2.50
- No. 2872C, 5 1/2 x 2 3/4 inches; two mortises for 18-point letter . . 1.75

No. 2752C. 75 cts.



EAGLES FOR BORDERS

No. 2752C. 75 cts. This fits in Border No. 2751C (\$1.50) with handsome effect. See page 818.

No. 2213 1/2 C. \$1.00. This fits in Border No. 2213C (\$2.00), 5 1/4 x 3 in., with handsome effect; similar in style to No. 2751C on page 818.

No. 2213 1/2 C. \$1.00



No. 3780C. 75 cts.



No. 514E. 25 cts.



No. 2385C. 75 cts.



No. 2471C. 50 cts.



No. 803E. 25 cts.



No. 2258C. Mortised. \$1.25



No. 3023C. 25 cts.



No. 3453C. 90 cts.



No. 2727C. 25 cts.



No. 2443C. 30 cts.



No. 3781C. 75 cts.



No. 3460C. 25 cts.



No. 2968C. 40 cts.



No. 2530C. 30 cts.



No. 3183C. \$1.25

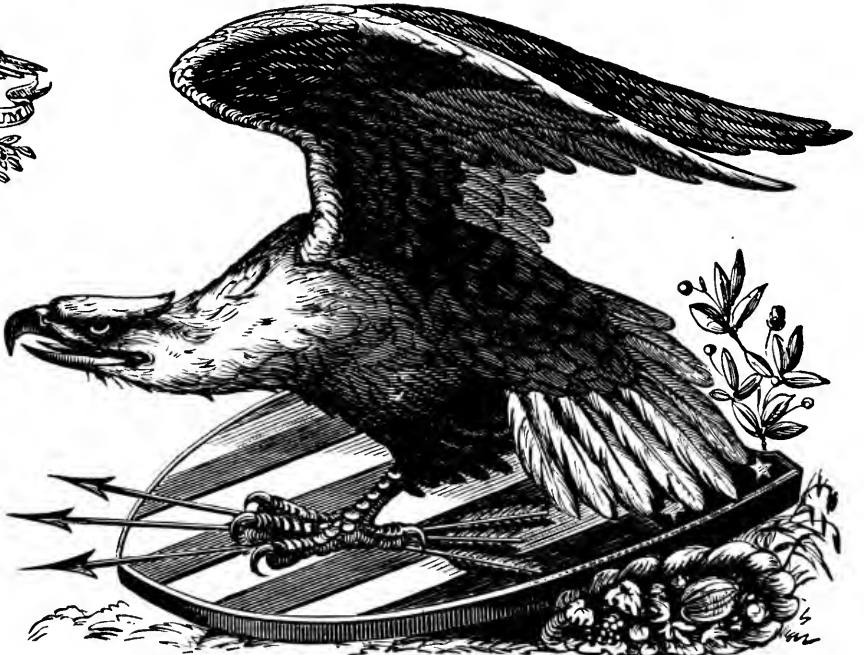

No. 3182C. 75 cts.



UNITED STATES FLAGS

All flags supplied for one or two colors. In ordering state if cuts are wanted for one or two colors.

OLD GLORY EMBOSSING SETS

A set includes plates for printing in three colors and an electro embossing die. Flag designs are alike in each set.

- Per set
- Set A. Length (staff), 2 in.; width over all, 1¾ in. . . . \$3.00
 - Set B. Length (staff), 4 in.; width over all, 3¼ in. . . . 4.50
 - Set C. Length (staff), 5¾ in.; width over all, 4½ in. . . . 6.00

No. 5144C. \$1.50

These handsome flags were designed and engraved by the American Type Founders Company. This style is made in three sizes, for either one or two colors; the two smallest are shown on this page (No. 5142C, No. 5144C). Dimensions of largest size (No. 5127½C): length of staff, 5 inches; width over all, 4 inches.



Set A. \$3.00. (For Embossing.)



OTHER SIZES: for dimensions see above.

- No. 5127½C. For one color \$2.25
- No. 5127C. For two colors (same size as 5127½C) . . . 3.50
- No. 5145C. For two colors (same size as 5144C) . . . 2.50
- No. 5143C. For two colors (same size as 5142C) . . . 2.00

No. 5142C. \$1.25

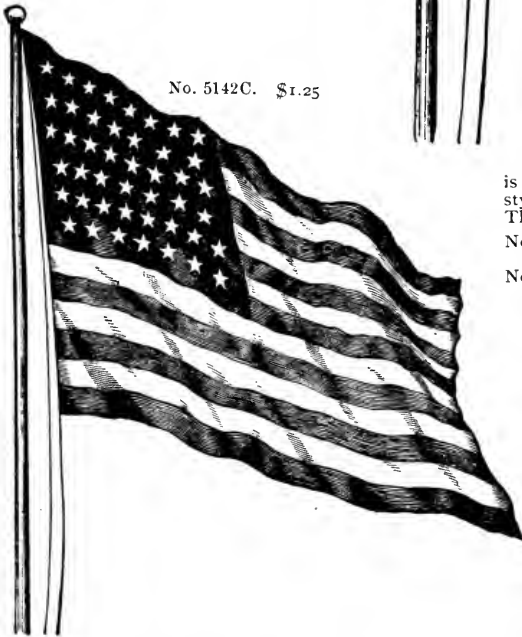

No. 2712C. 75c.

A companion flag to No. 2712C is also made, same size and style, but with staff to the left. This is No. 2713C.

- No. 2712C. Right \$0.75
- For two colors 1.50
- No. 2713C. Left 0.75
- For two colors 1.50

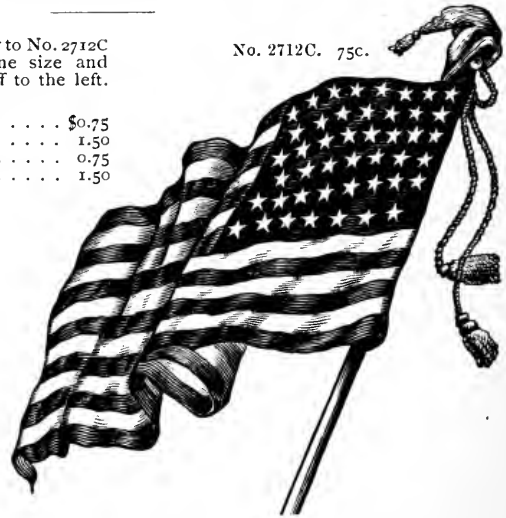

No. 2969C. (Cast in type mould.) 20 cents each; \$2.00 per dozen. For two colors, 40 cents per set; \$4.00 per dozen.



For Two-Color Flags, printed in colors, see page 755

No. 5107C. \$1.25. [Cuba Libre]



No. 5123C. 50 cts. [Bolivia]



No. 3998C. 75 cts. [Brazil]



OTHER SIZES:

No. 5112C. 1 7/8 x 2 1/4 in. \$1.25
 No. 5114C. 1 3/4 x 2 in. 1.00
 No. 5111C. 1 1/2 x 1 3/4 in. 0.75

OTHER SIZES:

No. 4000C. 2 1/4 x 2 in. \$1.25
 No. 3999C. 1 3/4 x 1 5/8 in. 1.00

**Coats-of-Arms
 of all South
 American
 Republics
 Supplied**

No. 2290 1/2 C. 75 cts.

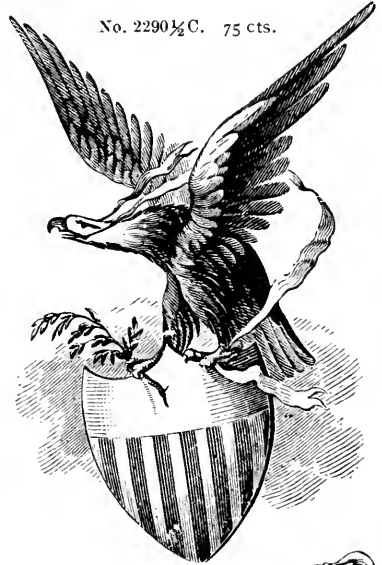

OTHER SIZES:

No. 5108C. 1 1/2 x 1 1/8 in. \$1.00 | No. 5109C. 1 1/8 in. sqr. \$0.75

No. 2559C. \$1.00 [Mexico]

No. 2441C. 50 cts.

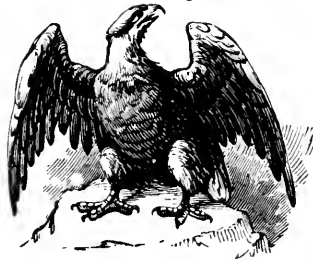

OTHER SIZE:

No. 2567C. 3 x 3 3/4 in. \$2.00

No. 2709C. 50 cts.

No. 2711C. 50 cts.

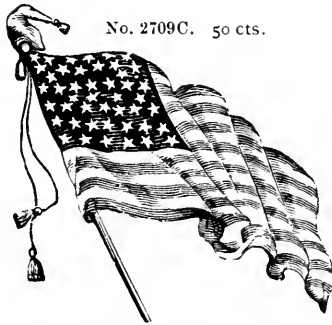

No. 2554C. 50 cts. [Mexico]



No. 12.134C. 35 cts.

No. 2546C. \$1.00

OTHER SIZE:

No. 2563C. 2 1/2 x 2 1/2 in. \$1.25



No. 12.137C. 60 cts.

No. 1863C. 35 cts.

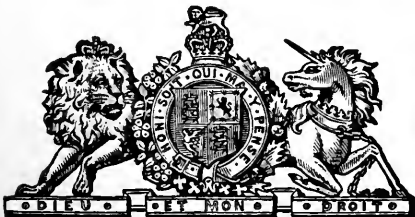

No. 3955C. 60 cts.

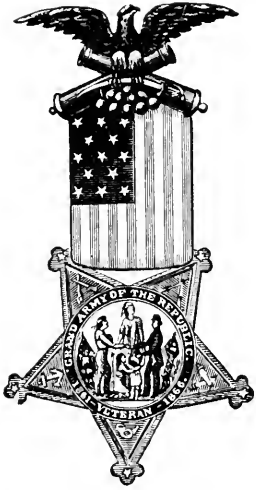

No. 3952C. \$1.00

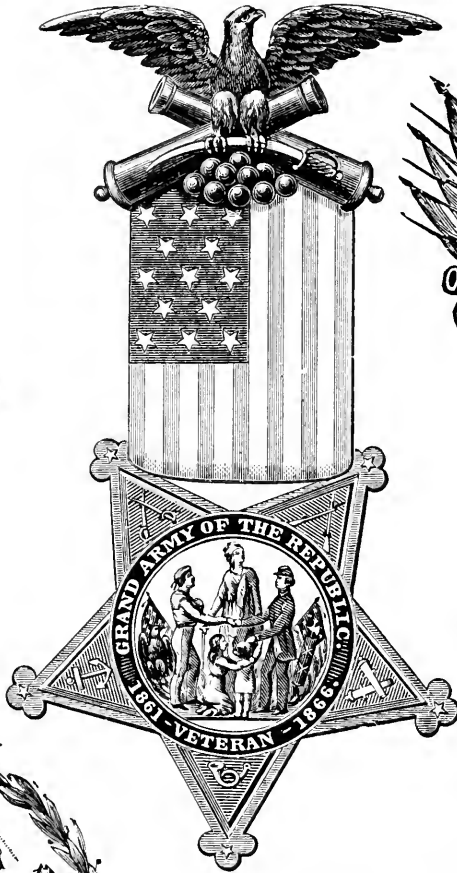

No. 200B. 75 cts.



No. 4125C. 30 cts.



No. 3953C. 75 cts.

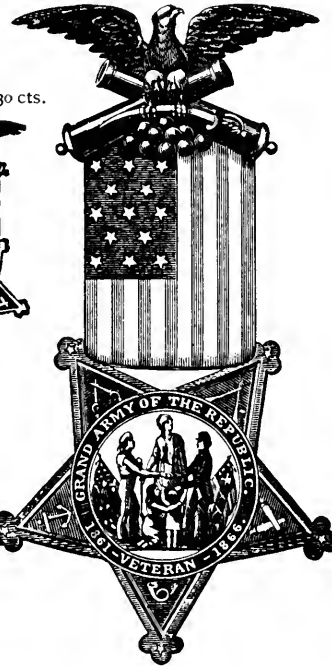

No. 193B. 30 cts.

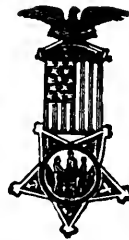

No. 2022E. 75 cts.



No. 196B. 50 cts.



No. 201B. 75 cts.



No. 202B. 75 cts.

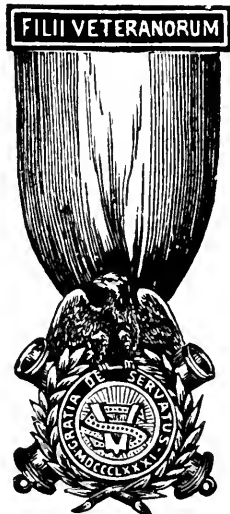

For four colors, \$2.50

No. 197B. 40 cts.



No. 198B. 50 cts.



No. 1109F. 75 cts.



No. 2435C. \$1.00

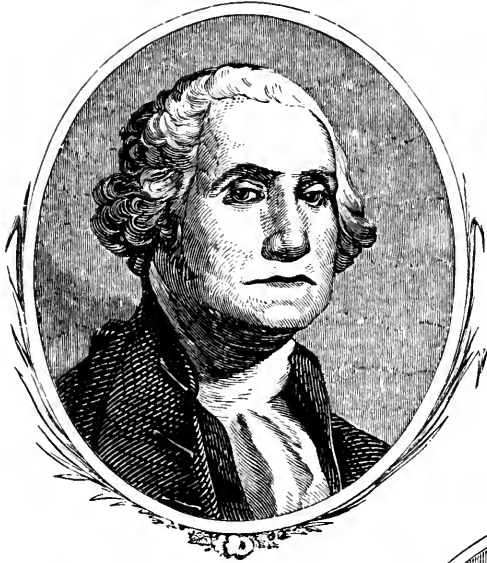

No. 2904C. 40 cts.



No. 4149C. 35c.



No. 3778C. \$1.00

No. 2708C. \$1.00



No. 3938C. 75 cts.



No. 4141C. 60 cts.

No. 4095C. 35 cts.



No. 3779C. 60 cts.



No. 161B. \$1.00



No. 3818C. 75 cts.

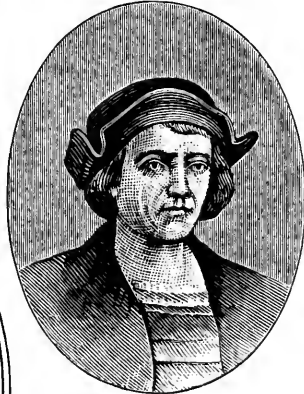

No. 4148C. 40 cts.

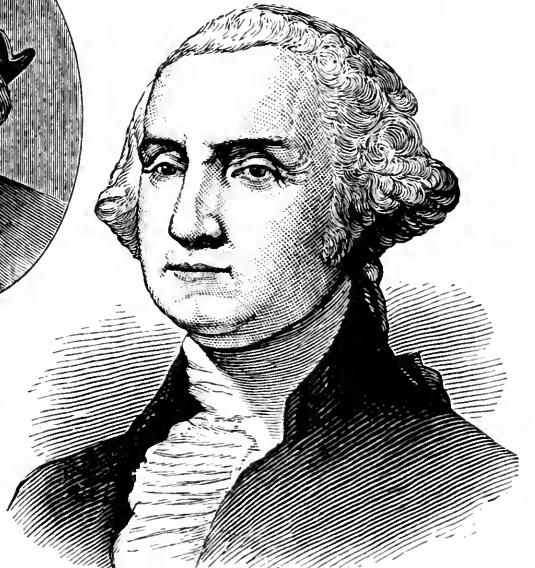
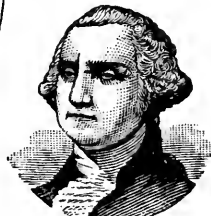

SOCIETY EMBLEMS

No. 216B. 75 cts.

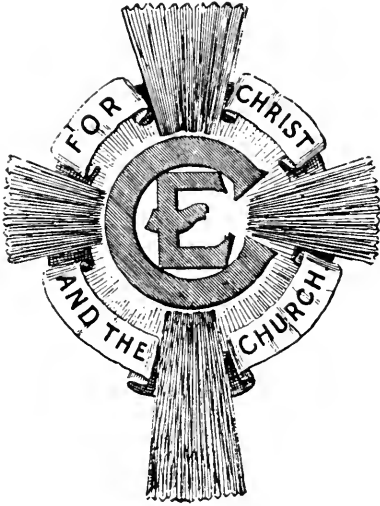

For two colors, \$1.25

No. 226B. 75 cts.



No. 217B. 30 cts.



No. 220B. 30 cts.



No. 215B. 75 cts.



No. 229B. 40 cts.



No. 239B. 75 cts.



No. 223B. 50 cts.

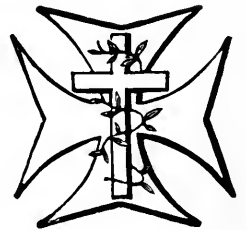

No. 4152C. 40 cts.



No. 4153C. 30 cts.



No. 214B. 60 cts.

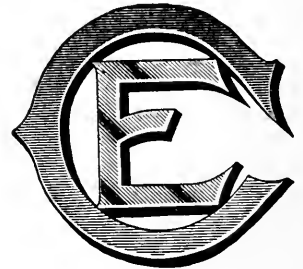

No. 227B. 40 cts.



No. 213B. 75 cts.

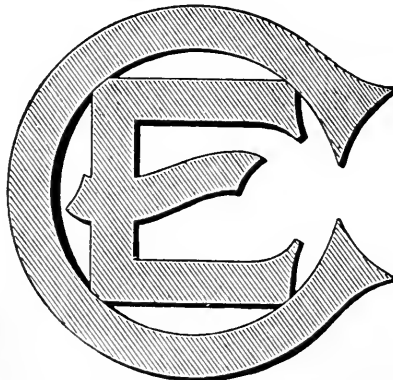

No. 233B. 50 cts.

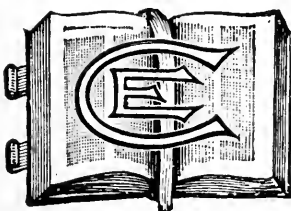

No. 230B. 60 cts.



No. 228B. 75 cts.

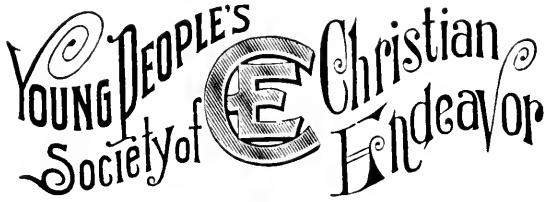

No. 221B. 25 cts.



No. 225B. 50 cts.



No. 232B. 50 cts.

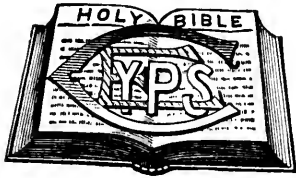

No. 224B. 60 cts.



No. 244B. 75 cts.

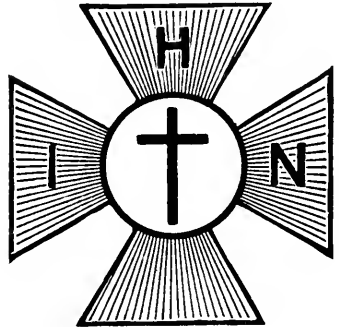

No. 222B. 40 cts.



No. 278B. 40 cts.



No. 231B. \$1.00

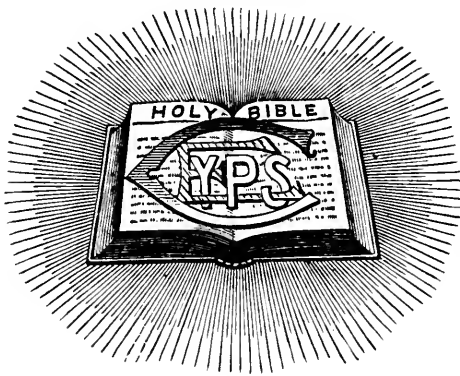

No. 242B. 40 cts.

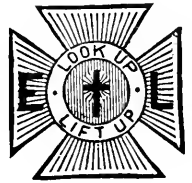

No. 240B. 40 cts.



No. 245B. 25 cts.



No. 241B. 40 cts.



No. 243B. 40 cts.



No. 236B. 40 cts.



No. 235B. 40 cts.



No. 234B. 50 cts.

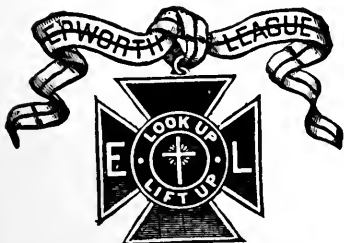

No. 238B. 50 cts.



No. 237B. 60 cts.



No. 2077E. 50c.

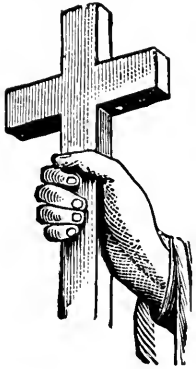

No. 2309 1/2 C. 40c.

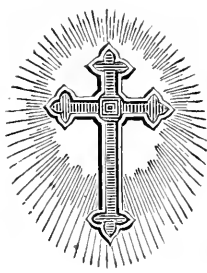

No. 3170C. 40c.

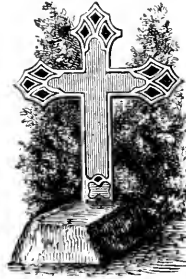

No. 3163C. 40c.



No. 3361C. 50c.



No. 2135C. 30c.

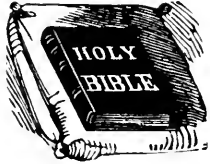

No. 3172C. 30c.



No. 3030C. 30c.

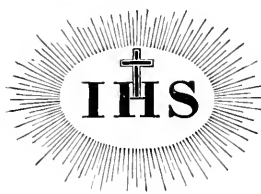

No. 420C. 30c.



No. 3171C. 30c.



No. 3455C. 40c.

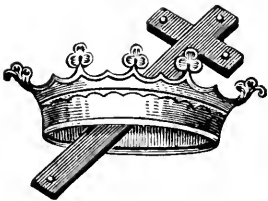

No. 3169C. 75c.

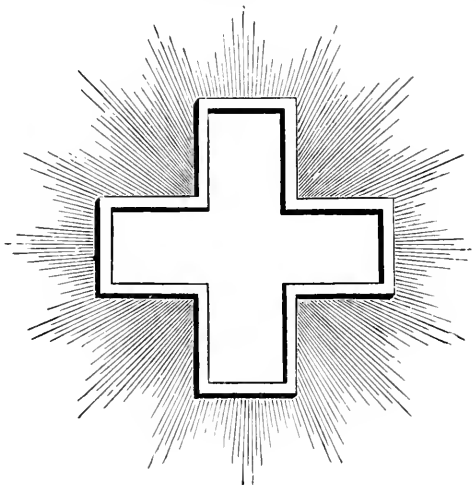

No. 3166C. 40c.

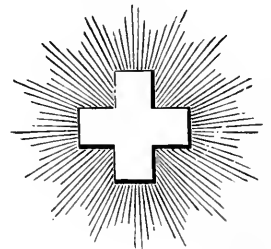

No. 1225C. 30c.



No. 3653C. 30c.



No. 3359C. 25c.



No. 3655C. 30c.



No. 3372C. 35c.



No. 2998C. 25c.



No. 2971C. 25c.



No. 3002 1/2 C. 15c.



No. 236C. 10c.



No. 3279C. 50c.

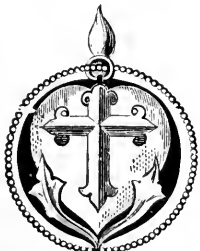

No. 3407C. 60c.

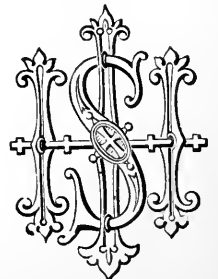

No. 3031C. 30c.



No. 3362C. 30c.



No. 2080E. 35c.



No. 3355C. 35c.



No. 2079E. 75c.

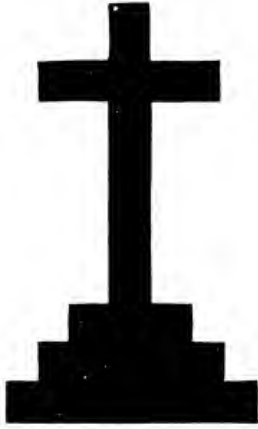

No. 3364C. 30c.



No. 3165C. 40c.

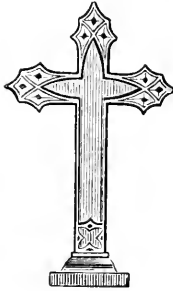

No. 3167C. 40c.

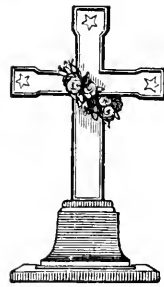

No. 3357C. 35c.



No. 3365C. 35c.



No. 3360C. \$1.50

No. 3384C. \$1.50

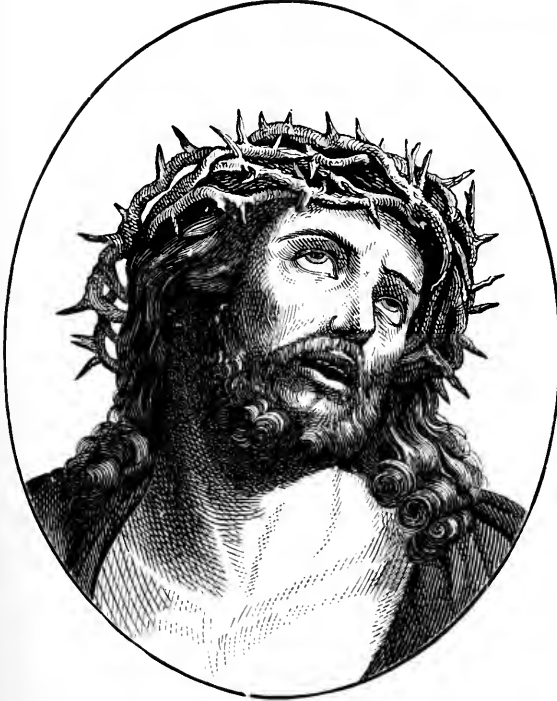

No. 2081E. 50c.



No. 2078E. \$1.00



No. 3356C. 40c.



No. 3383C. 35c.



No. 3354C. 35c.



No. 3358C. 25c.



No. 3363C. 30c.



No. 3083A. 50 cts.



No. 3079A. 50 cts.



No. 168B. 60 cts.

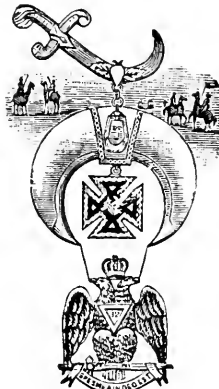

No. 4140C. 75 cts.

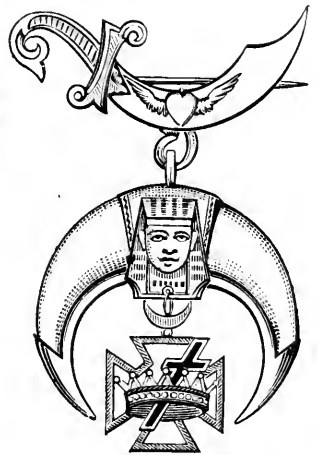

No. 3066A. 50 cts.



No. 3044A. 50 cts.



No. 3327A. 40 cts.



No. 2432C. 50 cts.



No. 3078A. 60 cts.

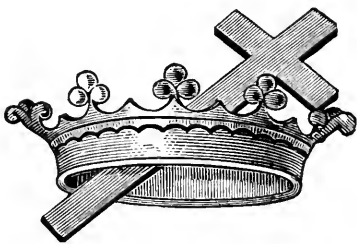

No. 1850A. 40 cts.



No. 3027A. 30c.

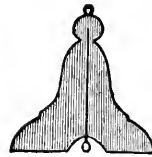

No. 3059A. 60 cts.



No. 2079A. 35 cts.



No. 172B. 25c.



No. 3109A. 25c.



No. 170B. 25c.



No. 166B. 25c.



No. 3323A. 40 cts.

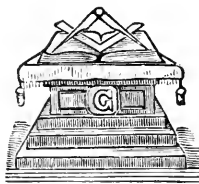

No. 3077A. 40 cts.



No. 3401C. 40 cts.



No. 3653C. 30 cts.



No. 428E. 20c.



No. 3402C. 40 cts.



No. 3403C. 40 cts.



No. 3404C. 40 cts.



No. 3400C. 40 cts.



No. 3399C. 40 cts.



No. 3970C. 50 cts.

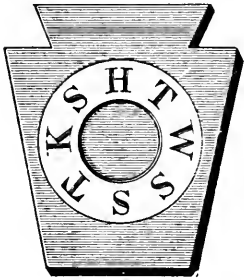

No. 3321A. 50 cts.



No. 3654C. 40 cts.



No. 1230F. 50 cts.

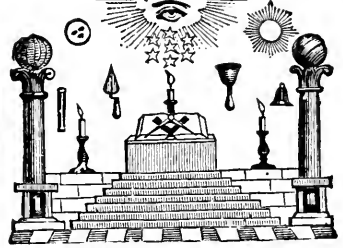

No. 3455C. 40 cts.

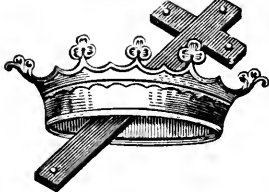

No. 81B. 15c. No. 83B. 15c. No. 79B. 15c.



No. 3454C. 75 cts.

No. 3024A. 30c.



No. 2431C. 60 cts.

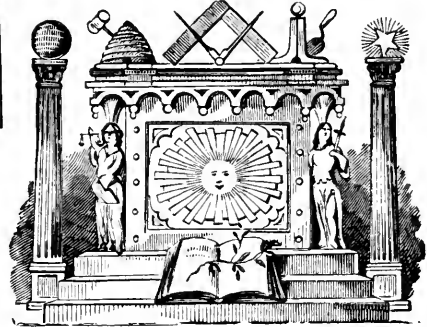

No. 3072A. 60 cts.

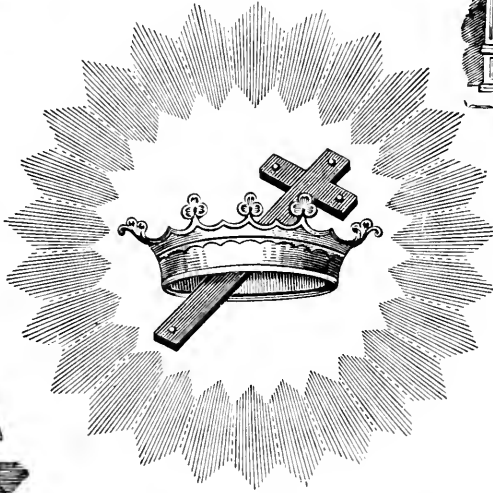

No. 77B. 15c. No. 82B. 15c. No. 80B. 15c.

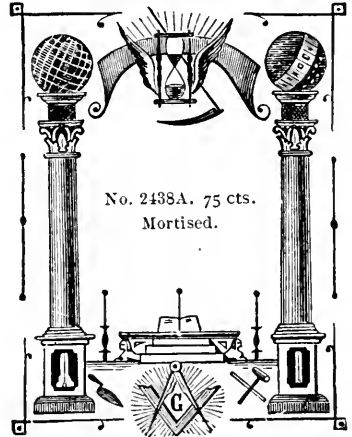

No. 2438A. 75 cts. Mortised.

No. 3682C. 50 cts.



No. 164B. 40 cts.

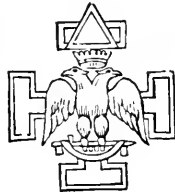

No. 2241A. 40 cts.



No. 163B. 60 cts.



For three colors, \$1.25

No. 3060A. 75 cts.



For three colors, \$1.25

No. 2434A. Mortised. 75 cts.

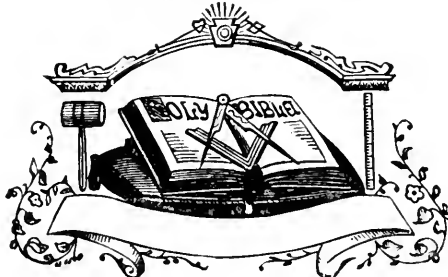

No. 2970C. 50 cts.



No. 3395C. 60 cts.



No. 3396C. 60 cts.



No. 3398C. 60 cts.



No. 3394C. 60 cts.

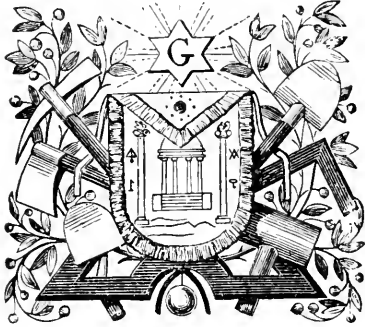

No. 3393C. 60 cts.



No. 3397C. 60 cts.



No. 2013E. 60 cts.

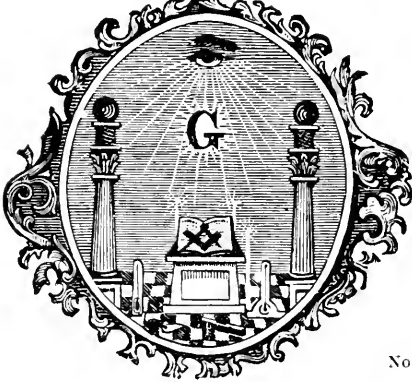

No. 2754A. 50 cts.



No. 3055A. 60 cts.



No. 1224F. 60 cts.

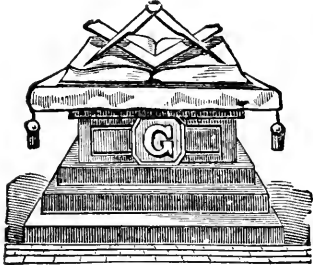

No. 3081A. 50 cts.



No. 916E. 30 cts.



No. 3061A. 50 cts.



No. 3033A. 50 cts.

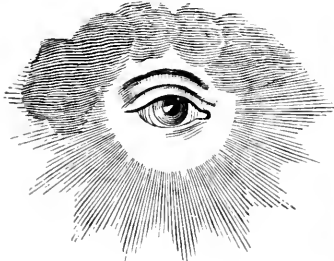

No. 3325A. 50 cts.

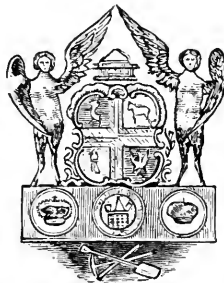

No. 3050A. 50 cts.

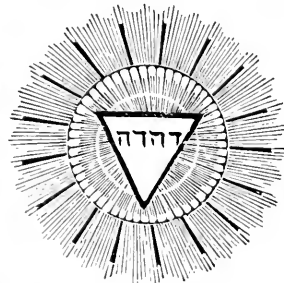

No. 3064A. 40 cts.



No. 3062A. 50 cts.

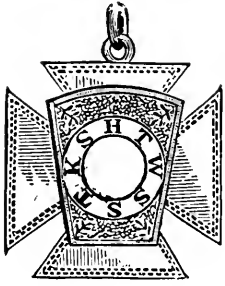

No. 3043A. 75 cts.

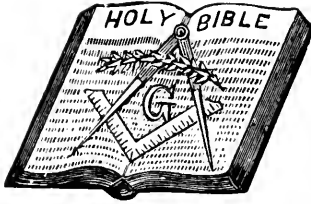

No. 3041A. 40 cts.



No. 3065A. 35 cts.



No. 3053A. 50c.

No. 1756A. 50c.

No. 3057A. 50 cts.

No. 3074A. 50 cts.

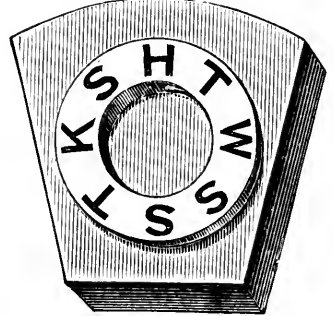
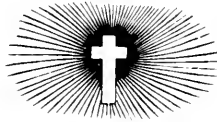

No. 3084A. 60c.

No. 901E. 25c.

No. 1702A. 50c.



No. 904E. 30c.

No. 1327F. 50c.

No. 869E. 30c.

No. 716E. 20c.

No. 3332A. 20c.



No. 3069A. 50 cts.

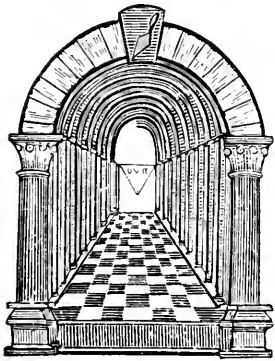

No. 2460C. 25c.



No. 3945C. 25 cts.



No. 2014E. \$1.25



No. 3070A. 50c.



No. 3075A. 75 cts.



No. 38B. 12 cts.



No. 3130A. 20 cts.



No. 2573A. 30 cts.



No. 1213F. 50 cts.



No. 3122A. 60 cts.



No. 3118A. 50 cts.

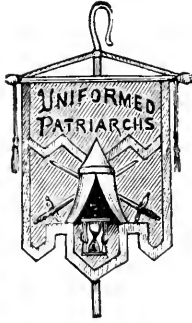

No. 174B. 60 cts.



No. 176B. 60 cts.



No. 3119A. 50 cts.

For two colors, \$1.20

For two colors, \$1.20

No. 3121A 60 cts.

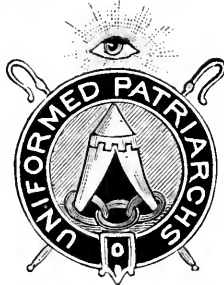
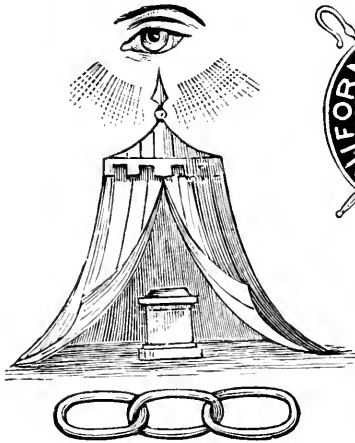

No. 3111A. 50 cts.

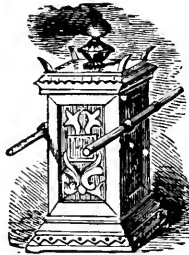

No. 3123A. 60 cts.

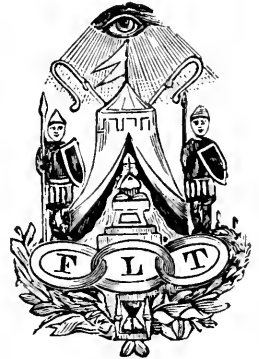

No. 175B. 75 cts.



No. 2015E. 60 cts.

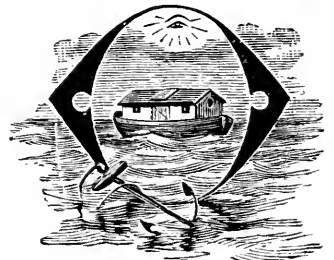

No. 3104A. 40 cts.



No. 1161F. 35 cts.



No. 179B. 25 cts.



No. 173B. 25 cts.



No. 3110A. 30 cts.



No. 177B. 25 cts.



No. 2766A. 75 cts.

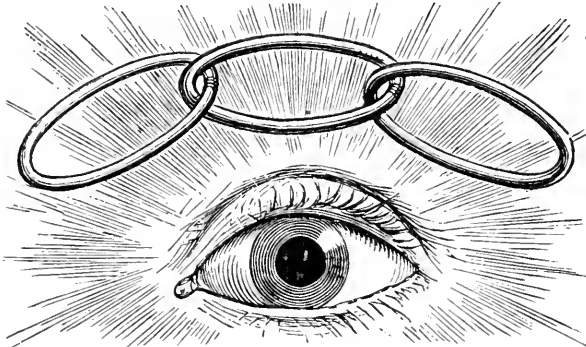

No. 180B. 25 cts.



No. 181B. 40 cts.



No. 2287A. 50 cts.



No. 1232F. 40 cts.



No. 1275F. 75 cts.



No. 3126A. 50 cts.



No. 3418C. 50 cts.



No. 3620C. 75 cts.



No. 1329F. 50c.



No. 186B. 75 cts.

No. 3417C. 25c.



No. 1211F. 35 cts.

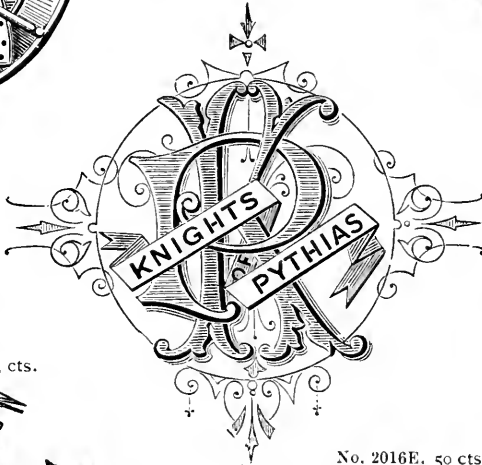

No. 3790C. 75 ct.

No. 185B. 75 cts.



No. 187B. 75 cts.



No. 2016E. 50 cts.



No. 3662C. 30 cts.



No. 188B. 75 cts.

No. 3419C. 60 cts.



No. 3683C. 50 cts.



For three colors, \$2.00

No. 3089A. 50 cts.



No. 3135A. 30c.



No. 1262F. 50 cts.



No. 3136A. 60 cts.



No. 267B. 45 cts.

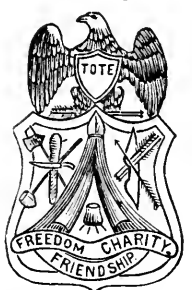

No. 1266F. 75 cts.

Imp. O.R.M.

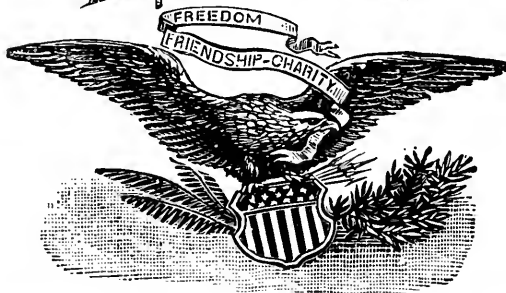

No. 1264F. 60 cts.



No. 183B. 30 cts.



No. 2820A. 40c.



No. 3657C. 40c.



No. 184B. 50 cts.



No. 3658C. 30c.



No. 3157A. 50 cts.

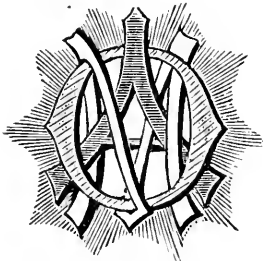

No. 3129A. 60 cts.



No. 3152A. 75 cts.



No. 3092A. 30 cts.



No. 192B. 60 cts.

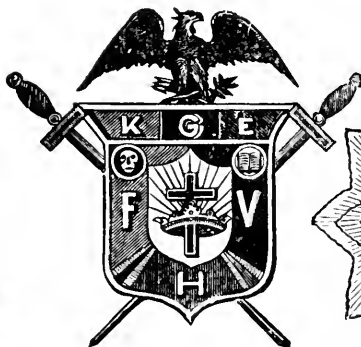

No. 3153A. \$1.00



No. 3972C. 60 cts.



No. 1361F. 50 cts.

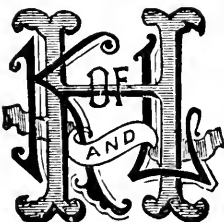

For four colors, \$2.00

Mortised for name of Lodge

No. 190B. 75 cts.

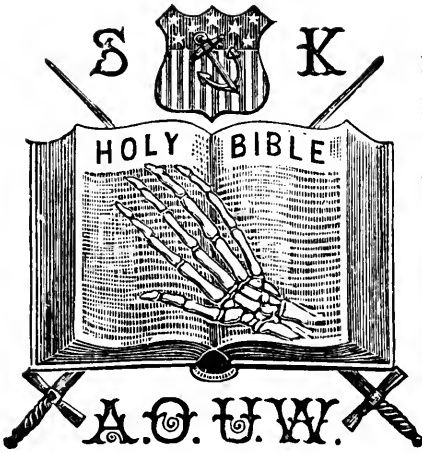

No. 401A. 40 cts.



No. 1238F. 75 cts.

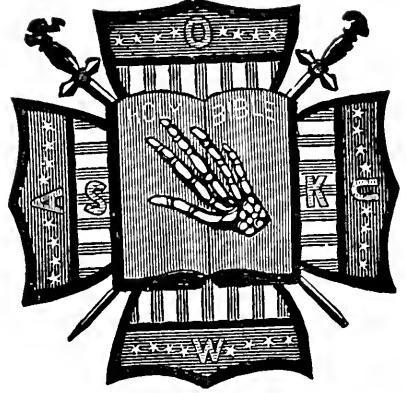

No. 1331F. 40 cts.



No. 3996C. 75 cts.

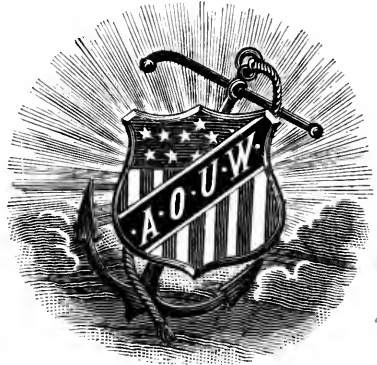

No. 3191A. 40 cts.

No. 191B. 40 cts.

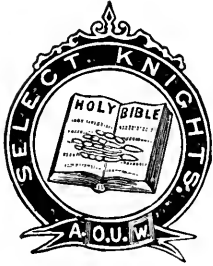

No. 3186A. 50 cts.



No. 3169A. 75 cts.



No. 2018E. \$1.00



No. 257B. 40 cts.



No. 3171A. 75 cts.



No. 254B. 75 cts.

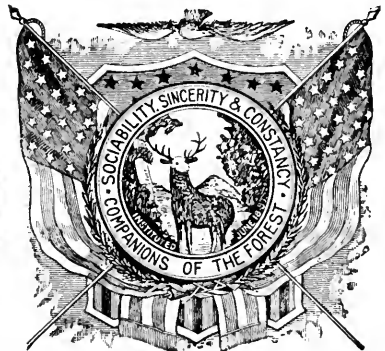

No. 1336F. 50 cts.



No. 4123C. 60 cts.

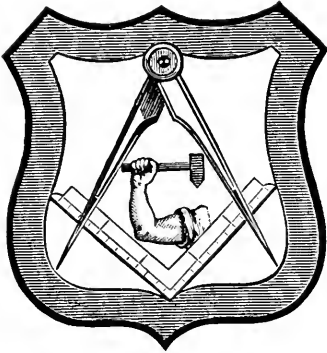

No. 903E. 30 cts.



No. 3190A. \$1.00



No. 3661C. 30 cts.

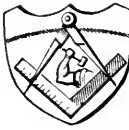

No. 3185A. 60 cts.



No. 3181A. 50 cts.

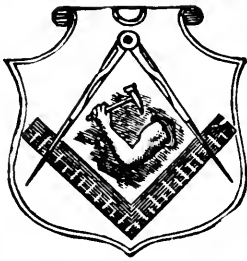

No. 4122C. 40 cts.

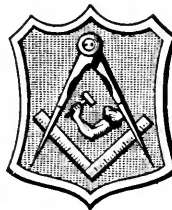

No. 4144C. 50 cts.

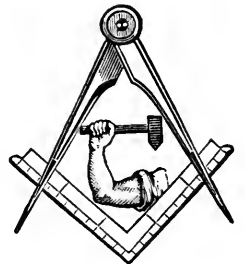

No. 3146A. 50 cts.

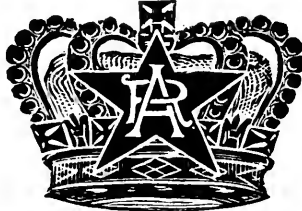

No. 3184A. 25c.



No. 1204F. 75 cts.



No. 3132A. 30 cts.



No. 3133A. 40 cts.



No. 3139A. 40 cts.



No. 1207F. 50 cts.



No. 247B. 40 cts.



No. 4124C. 75 cts.

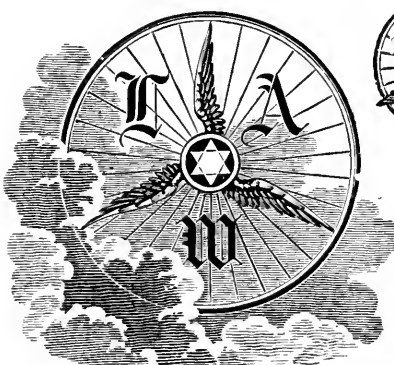

No. 246B. 30 cts.



No. 248B. 75 cts.



No. 4121C. 40 cts.





No. 3490C. Mortised. \$1.75

No. 3685C. 50 cts.

No. 3149A. 50 cts.

No. 3154A. 75 cts.

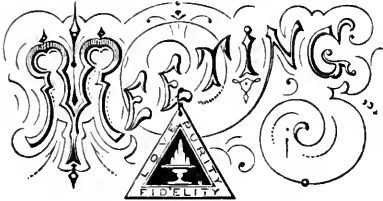

No. 2048C. 75 cts.



No. 3147A. 40 cts

No. 2319 1/2 A. 75 cts.



No. 3151A. 40 cts.

No. 3148A. 40 cts.

No. 3659C. 30 cts.



No. 1274E. 40 cts.



No. 3150A. 50 cts.



No. 2023E. 60 cts.

No. 3142A. 40 cts.



No. 2067E. 60 cts.



No. 256B. 60 cts.



No. 3166A. 60 cts.



No. 1328F. 60 cts.

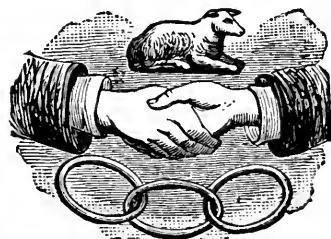

No. 2857A. 60 cts.

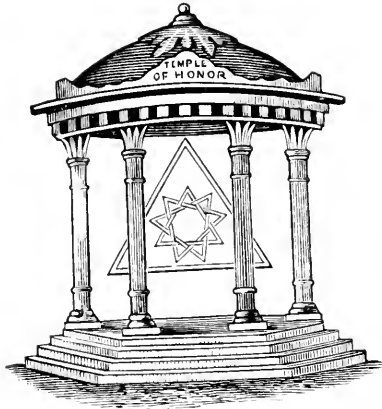

No. 268B. 75 cts.

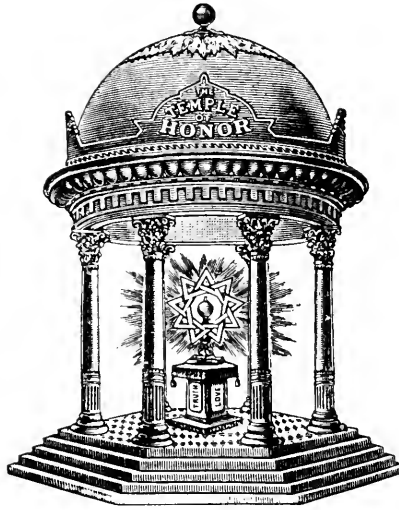

No. 1381F. 40 cts.

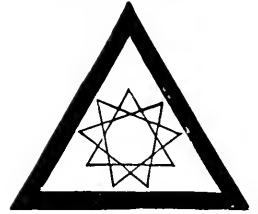

No. 3176A. 30 cts.



No. 902E. 30 cts.



No. 3138A. 30 cts.

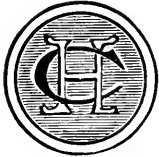

No. 261B. 40 cts.



No. 2011E. 60 cts.



No. 259B. 75 cts.

No. 260B. 75 cts.



No. 3196A. 75 cts.

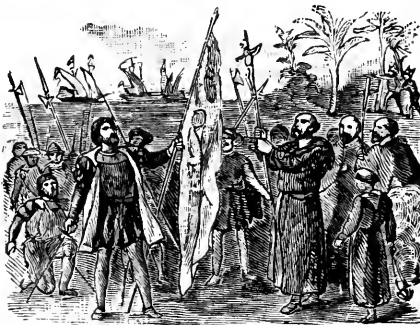

No. 3167A. 60 cts.

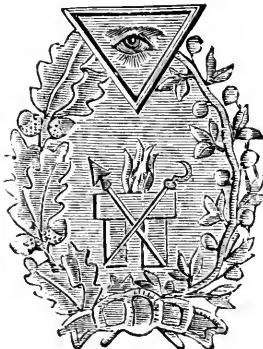

No. 4110F. 25c.



No. 1301F. 40 cts.



No. 2024E. 40c.



No. 2007E. 75 cts.



No. 3155A. 75 cts.

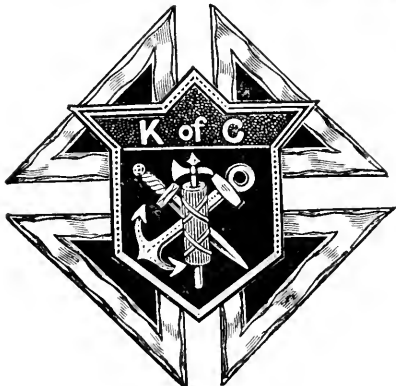

No. 4185C. 50 cts.



No. 204B. 60 cts.

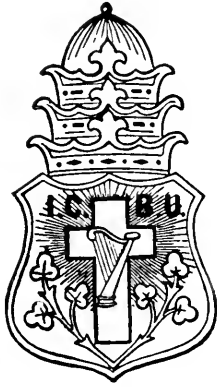

No. 3177A. \$1.00

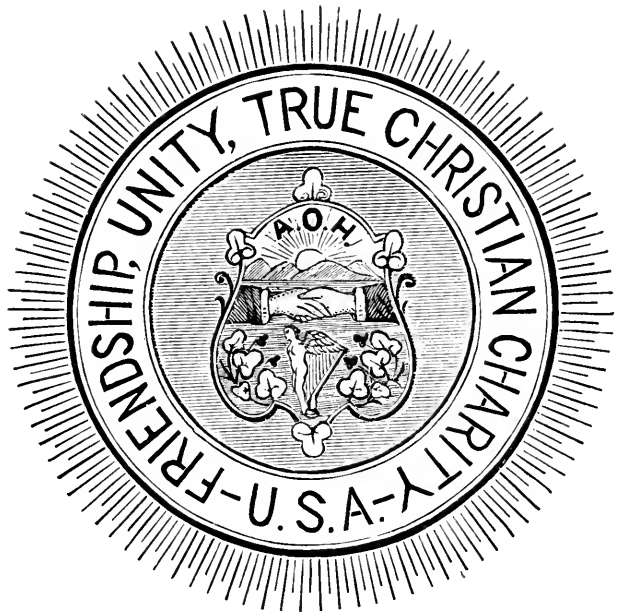

No. 205B. 50 cts.



No. 1840C. 30 cts.



No. 987A. 50 cts.



No. 3172A. 50 cts.



No. 203B. 60 cts.



No. 210B. 60 cts.



No. 209B. 50 cts.



No. 3171C. 35 cts.



No. 3174A. 35 cts.



No. 3178A. 50 cts.



No. 2069A. 30c.



No. 3173A. 75 cts.



No. 3175A. 40 cts.



No. 207B. 75 cts.



No. 3163A. \$1.00



No. 206B. 50 cts.



No. 3160A. 40 cts.



No. 3144A. 40 cts.

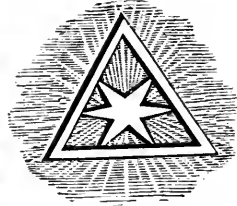

No. 211B. 50 cts.



No. 212B. 75 cts.



No. 208B. 30 cts.



No. 3145A. 30c.



No. 3143A. 50 cts.

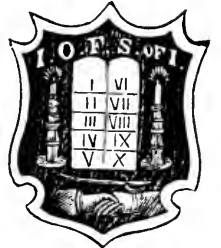

No. 1273F. 50 cts.



No. 3170A. 50 cts.

No. 262B. 50 cts.



No. 263B. 60 cts.



No. 1285F. 60 cts.



No. 3189A. 40 cts.



No. 258B. 50 cts.

No. 3194A. 75 cts.



No. 12,167C. 40 cts.



No. 4362A. 60 cts.
Sons of the Revolution.

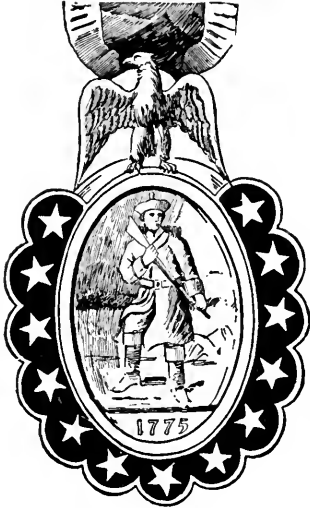

No. 4395A. 60 cts.
Sons of American Revolution



No. 4368A. 60 cts.
Military Order of Loyal Legion of U. S.



No. 4388A. 75 cts.
Naval Order of U. S.



No. 4364A. 60 cts.
Daughters of the Revolution.



No. 4361A. 60 cts.



No. 4366A. 60 cts.
Society of Colonial Wars.



No. 4393A. 60 cts.
Military Order of Foreign Wars of U. S.



No. 4363A. 60 cts.
Daughters of American Revolution.



No. 4389A. 60 cts.



No. 4396A. 60 cts.



No. 4394A. 60 cts.



No. 4398A. 65 cts.
Medal of Honor Legion.

No. 3131A. 35 cts.
Legion of Honor.



No. 1343F. 60 cts.

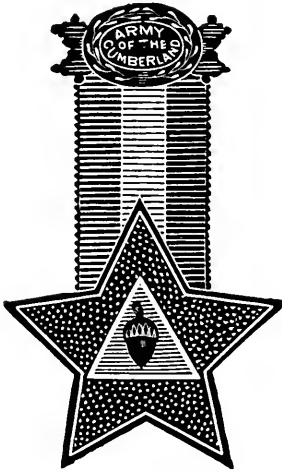

No. 4397A. 75 cts.



No. 4365A. 60 cts.
U. S. Daughters War of 1812.

No. 199B. 75 cts.

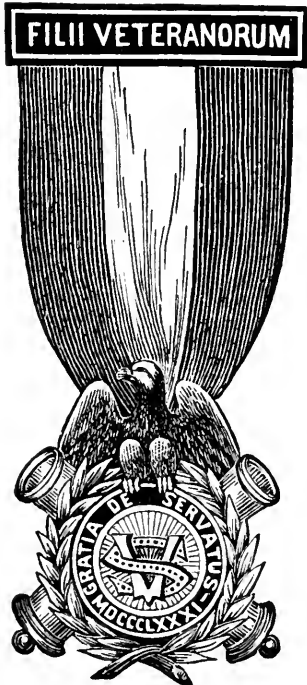

No. 2029E. 60 cts.

No. 4392A. 60 cts.
Society of Wars of 1812.



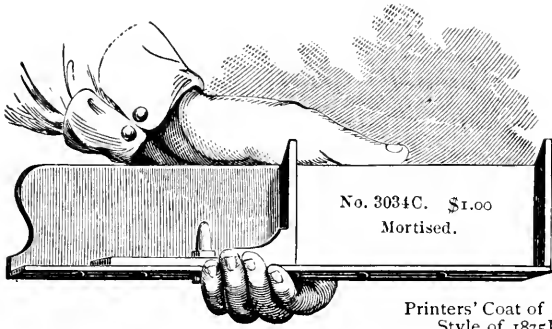

No. 1874D. 60 cts.



No. 3280C. 40 cts.



No. 3273C. 75 cts.

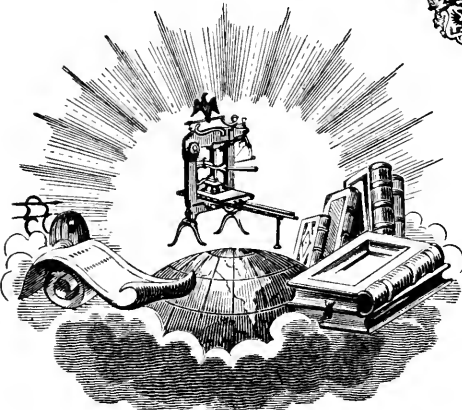

No. 3271C. 60 cts.

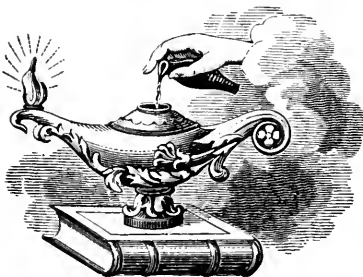

Printers' Coat of Arms, Style of 1875D.

We have three other sizes:

No. 1877D, 3 1/4 ins., \$2.00

No. 1876D, 2 1/2 ins., 1.50

No. 1872D, 1 1/4 in., .50

Cuts 1874D, 1875D,

1876D, 1877D also fur-

nished to work in six

colors; 1873D for four

colors; 1872D for three

colors; 1871D for two

colors.

No. 1873D. 50 cts.



No. 1871D. 30c.

No. 1870D. 25c.



No. 3290C. 50 cts.



No. 3784C. 50 cts.



No. 1875D. 75 cts.



No. 3272C. 50 cts.



No. 3143C. 75 cts.



No. 3153C. 60 cts.



No. 4176C. Mortised for Name. Price, per Set, \$2.00



No. 4179C. Per Set, \$1.00



Not Mortised.



No. 4181C. Mortised for Name. \$1.75



No. 4178C. Mortised for Name. Price per Set, \$2.00



No. 5091C. 60 cts.

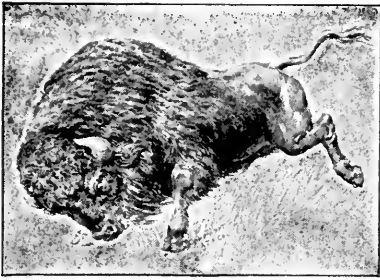

No. 5100C. 40 cts.



No. 5164C. 60 cts.



No. 5160C. 75 cts.



No. 5163C. 75 cts.



No. 5099C. 60 cts.

No. 5098C. 35 cts.



No. 5097C. 60 cts.



No. 5096C. 50 cts.



No. 2076E. 40 cts.



No. 5162C. \$1.00



No. 3787C. 70 cts.



No. 3793C. 75 cts.

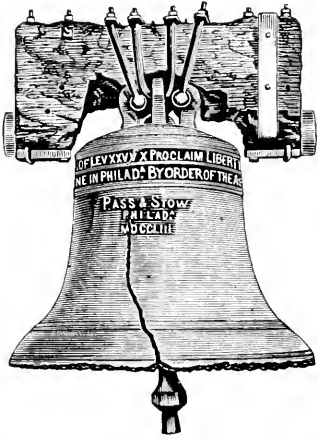

No. 4096C. \$1.25

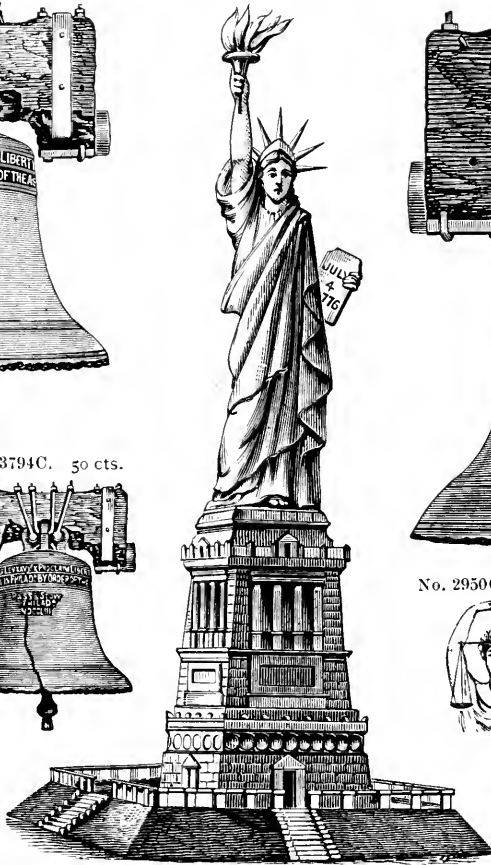

No. 3796C. \$1.00

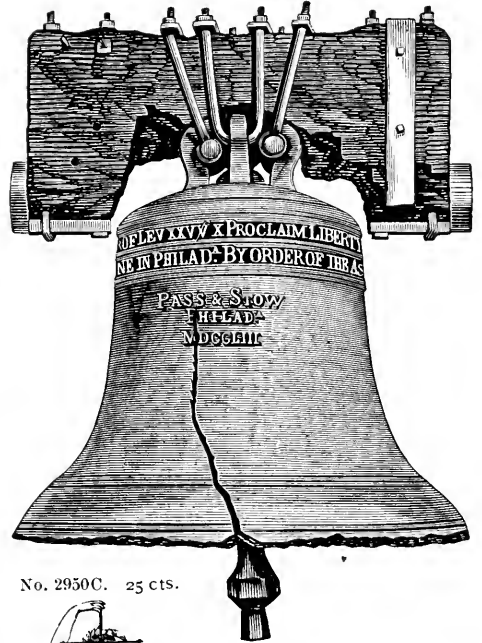

No. 2016C. 25c.



No. 3794C. 50 cts.

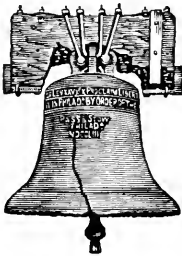

No. 2950C. 25 cts.



No. 2941C. 20c.



No. 3142C. 75 cts.



No. 2408C. \$1.00



No. 3476C. 60 cts.



No. 2942C. 20 cts.



No. 2948C. 20 cts.



No. 2441C. 75 cts.



No. 3438C. 40 cts.



No. 3944C. 25 cents each; \$2.00 per dozen.



No. 3051C. 60 cts.

No. 3289C. 30 cts.

No. 12.180C. 40 cts.

No. 3146C. 40 cts.

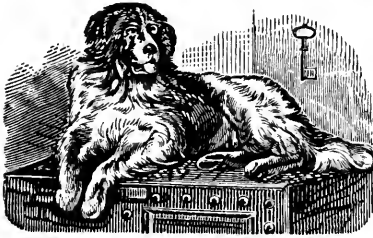

No. 3445C. 40 cts.

No. 2395C. 20 cts.

No. 2317C. 50 cts.

No. 2926C. Mortised. \$1.00



No. 2951C. 20c.



No. 2197C. 75 cts.

No. 3409C. 60 cts.

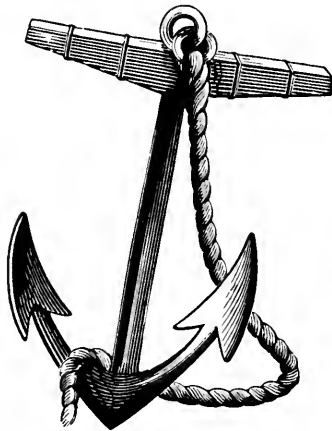

No. 3948C. Mortised. 75 cts.

No. 3175C. 60 cts.

No. 2937C. 40 cts.

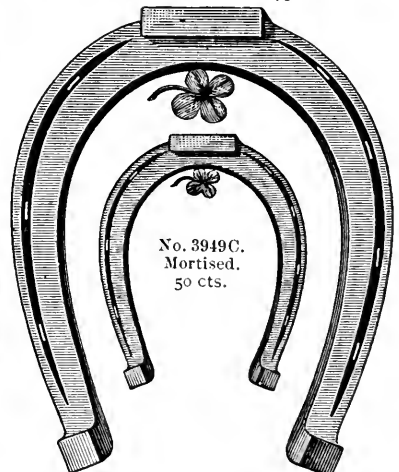

No. 3949C. Mortised. 50 cts.

No. 2882A. 30c.



No. 2040E. 25c.



No. 3982C. 30c.



No. 2038E. 25c.



No. 2033E. \$1.00



No. 2039E. 35c.



No. 2034E. 60 cts.



No. 3954C. 50 cts.

No. 2974C. 35 cts.

No. 2036E. 40 cts.

No. 2037E. 50 cts.

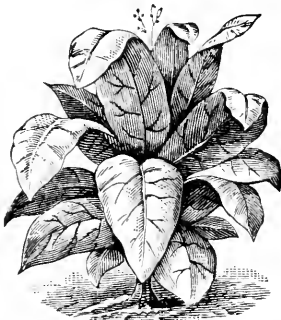

No. 1824D. 75 cts.



No. 1744D. 35 cts.

No. 132B. 30 cts.

No. 2997C. 75 cts.

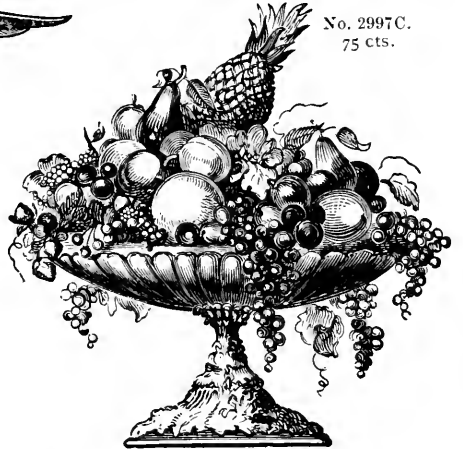
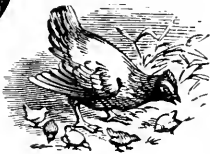

No. 2042E. 40 cts.

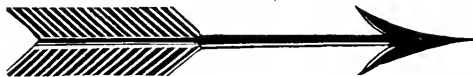

No. 3426C. 60 cts.

No. 2477C. \$1.00

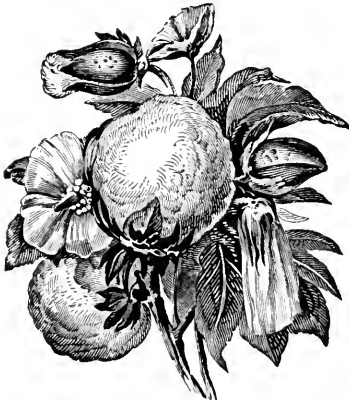

No. 4119C. 75 cts.



No. 12.178C. 40 cts.



No. 2425C. 30 cts.



No. 2466C. 50 cts.



No. 2681C. 75 cts.

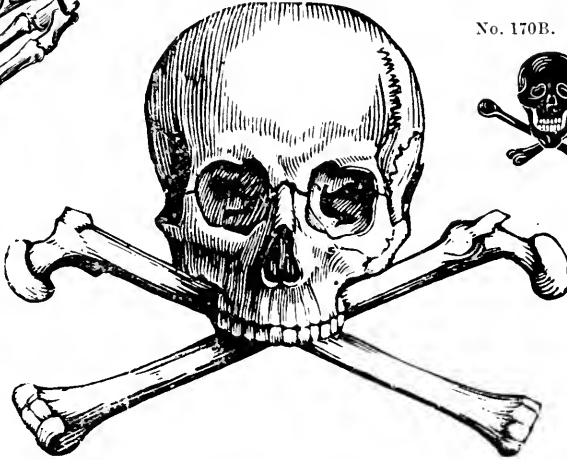

No. 170B. 25 cts.



No. 700E. 30 cts.



No. 868E. 30 cts.



No. 61C. 20c.



No. 865E. 25c.



No. 436E. 20c.



No. 2045E. 30c.



No. 3462C. 75 cts.

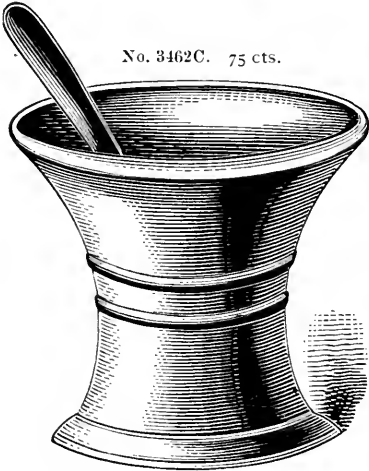

No. 96B. 25 cts.



No. 507E. 25 cts.

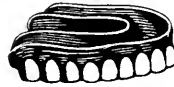

No. 276B. 40 cts.

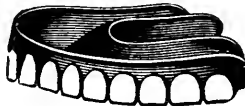

No. 455E. 20 cts.



No. 532E. 25 cts.



No. 4115F. 30 cts.



No. 2678C. 50 cts.

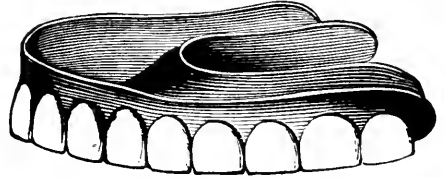

No. 3410C. 75 cts.



No. 12.176C. 60 cts.

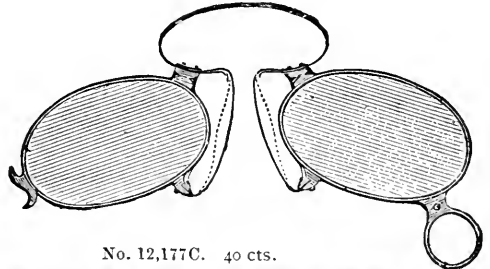

No. 12,177C. 40 cts.

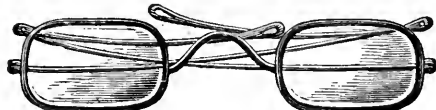

No. 4186C. 50 cts.

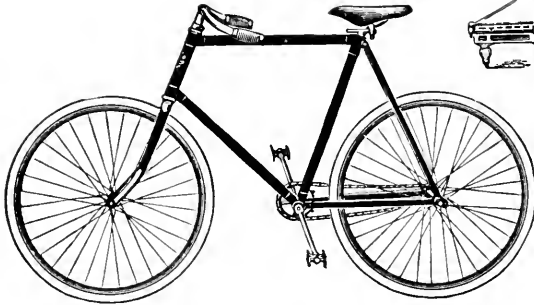

No. 4020F. 20 cts.



No. 4188C. 50 cts.

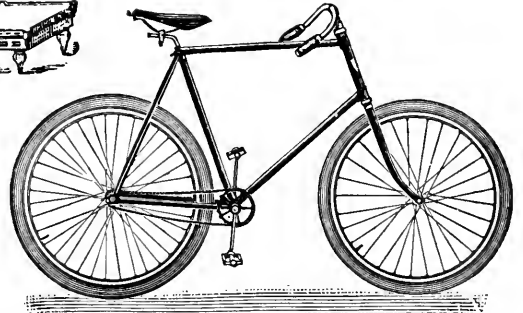

No. 4123F. 35 cts.



No. 10,332D. 60 cts.

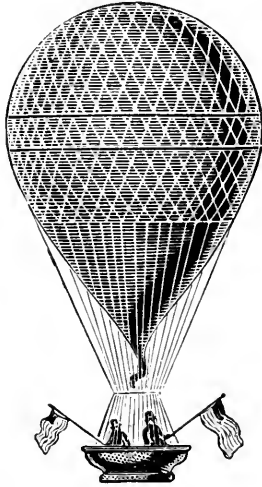

No. 2906C. 50 cts.

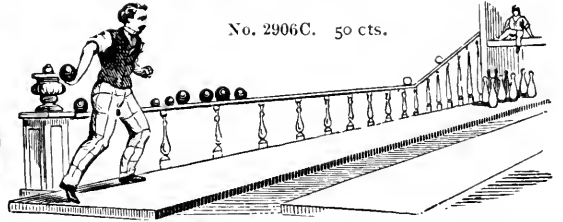

No. 468E. 20 cts.



No. 3388C. 75 cts.

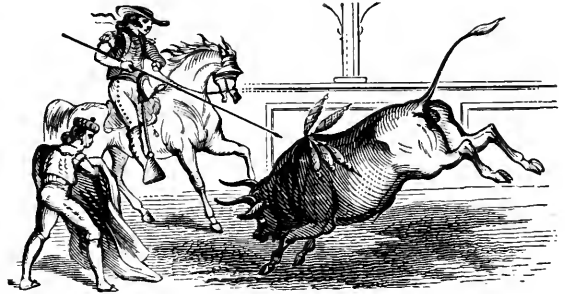

No. 743E. 20 cts.



No. 4124F. 30c.



No. 4125F. 30c.



No. 4126F. 40 cts.



No. 3785C. 60 cts.

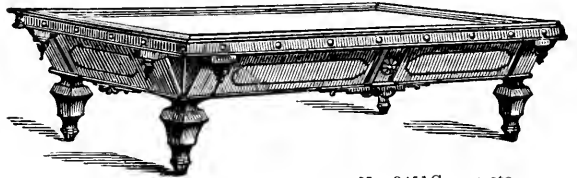

No. 3451C. 50 cts.

No. 3957C. 40 cts.

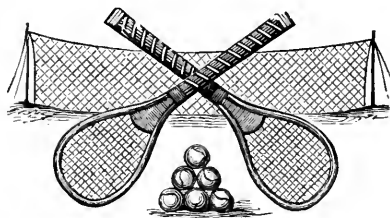

No. 4122F. 30c.

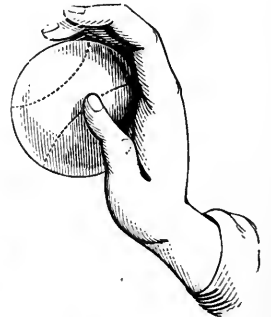

No. 744E. 25 cts.



No. 2905C. 60 cts.

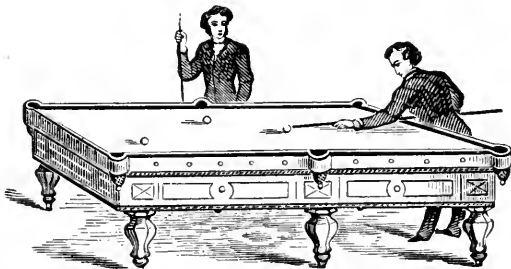

No. 12,173C. 40 cts.

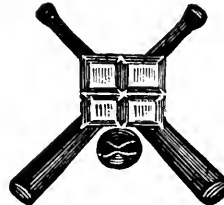

No. 2687C. 30 cts.

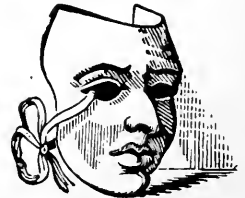

No. 2092C. 50 cts.



No. 804E. 25 cts.

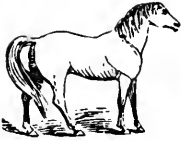

No. 3037C. 50 cts.



No. 3378C. 40 cts.



No. 3436C. 50 cts.



No. 2052E. 75 cts.

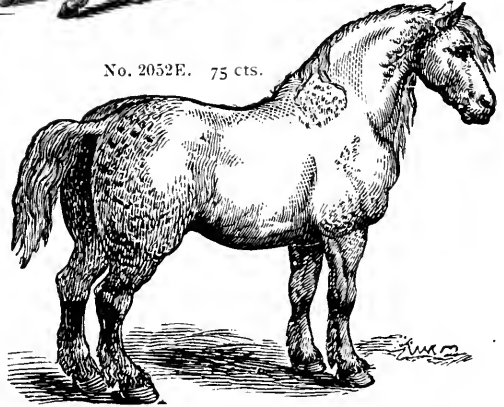

No. 3204C. 50 cts.

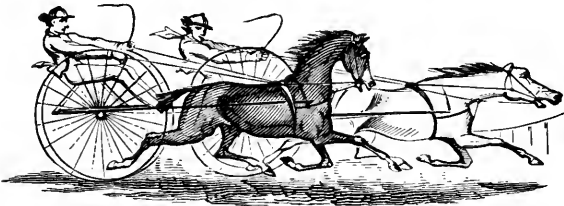

No. 2658F. 25c.



No. 3038C. 60 cts.

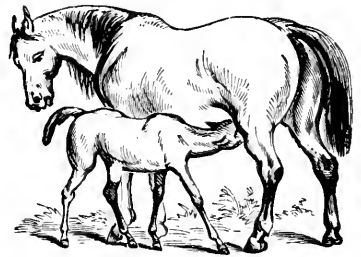

No. 3370C. 50 cts.



No. 2695C. 75 cts.

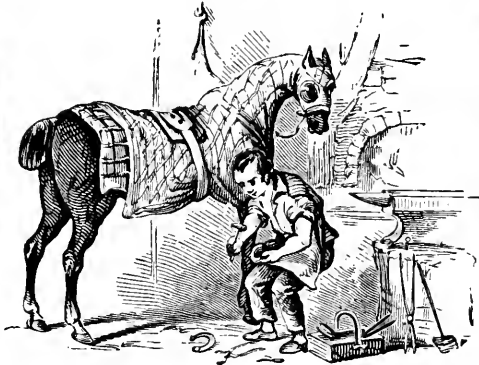

No. 3288C. 50 cts.



No. 2054E. 75 cts.



No. 2055E. 75 cts.



No. 2057E. \$1.00

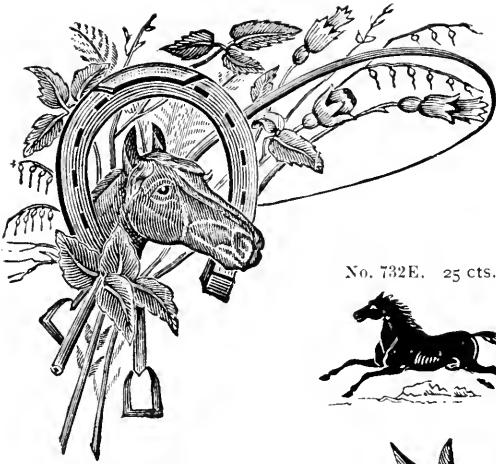

No. 1629D. 60 cts.

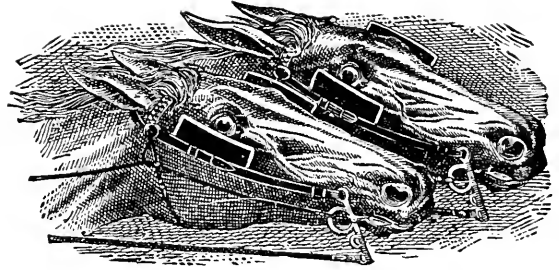

No. 732E. 25 cts.



No. 1856C. 50 cts.



No. 1796D. 35 cts.

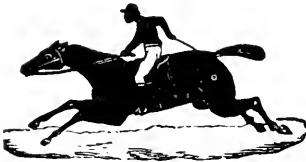

No. 3434C. \$1.50

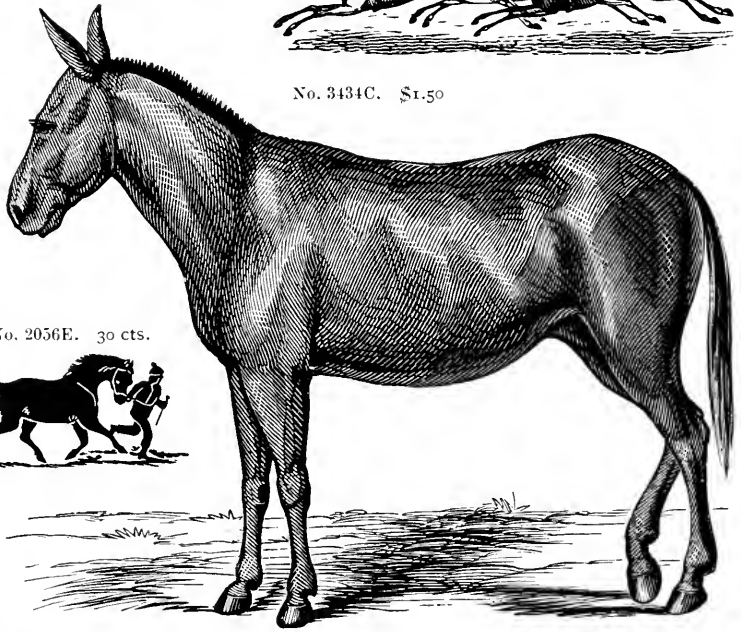

No. 2312½C. 40 cts.

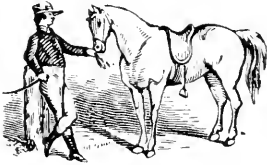

No. 2056E. 30 cts.



No. 1733C. 50 cts.

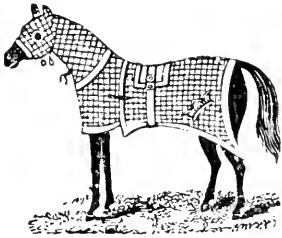

No. 3450C. \$1.50

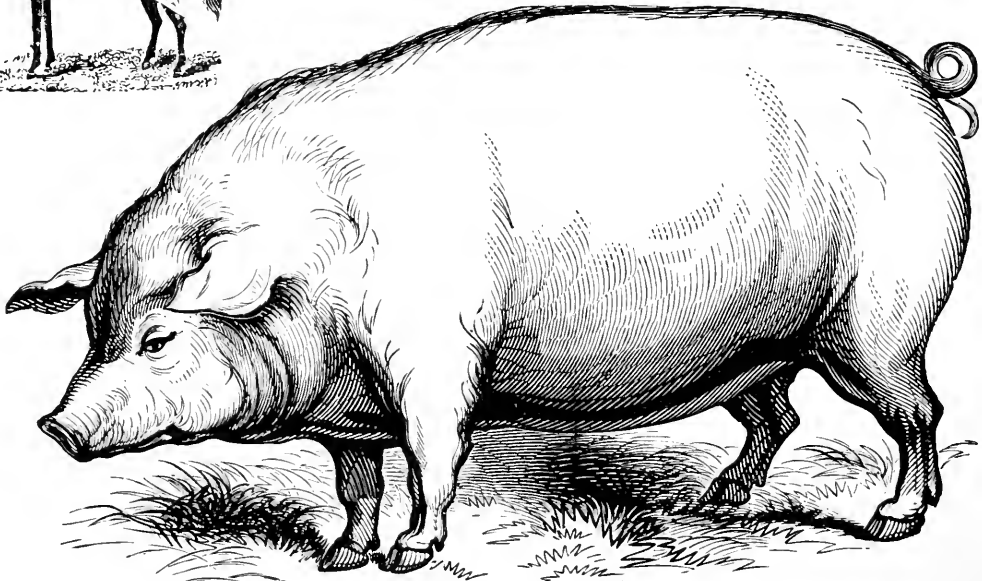

No. 2070C. \$2.00

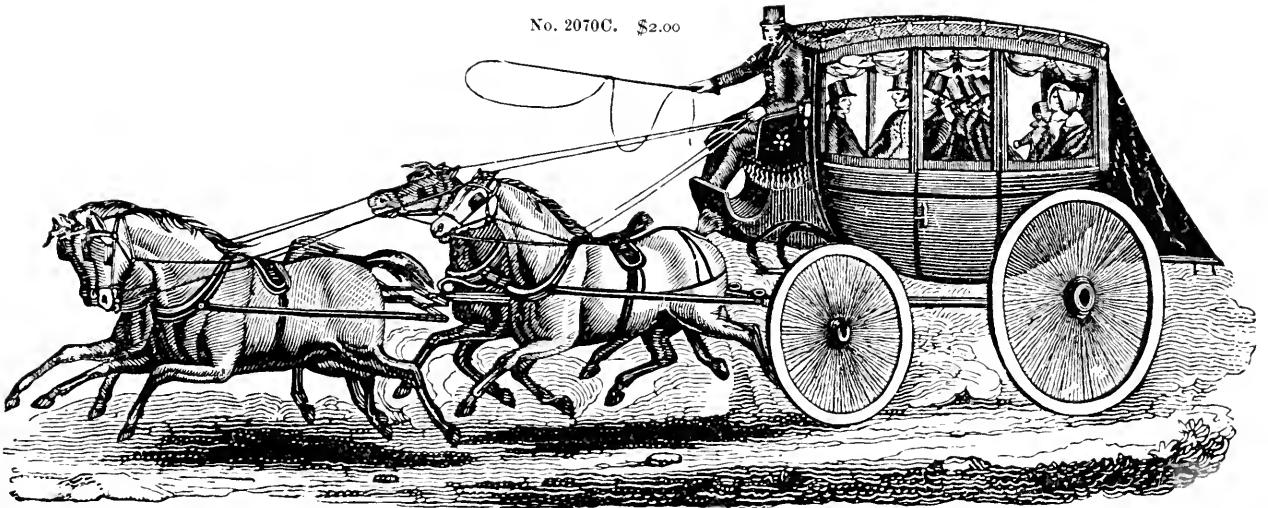

No. 1857C. 50 cts.

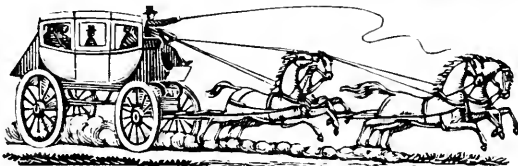

No. 2066E. 50 cts.

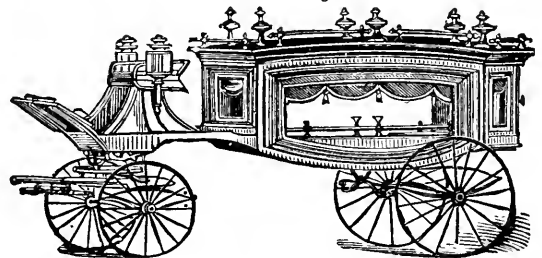

No. 3456C. 50 cts.

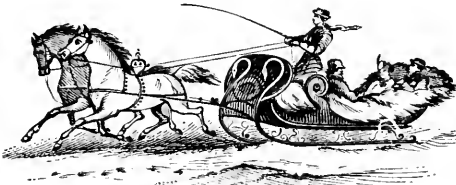

No. 3380C. 50 cts.



No. 2470C. 60 cts.

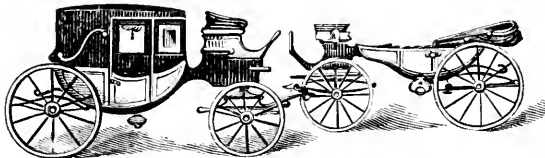

No. 2064E. \$1.00

No. 464E. 20 cts.

No. 2817C. 50 cts.

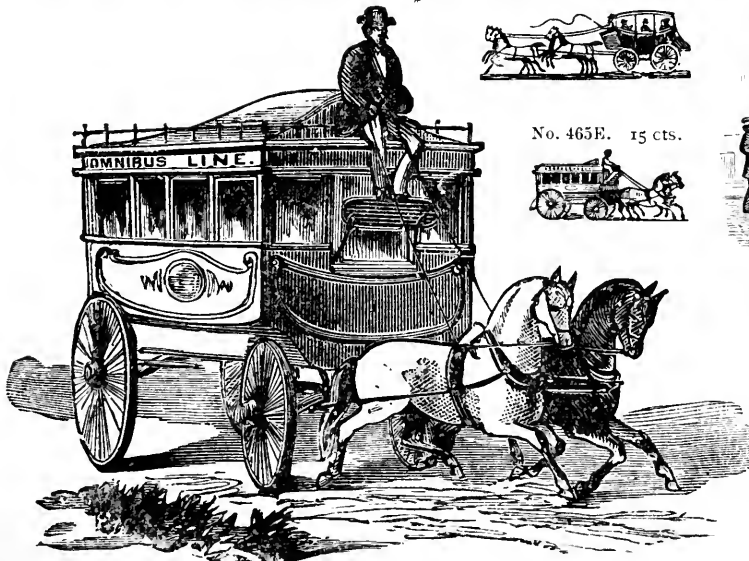

No. 465E. 15 cts.



No. 2063E. 40 cts.

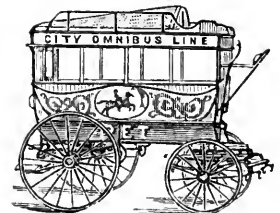

No. 2854C. 50 cts.

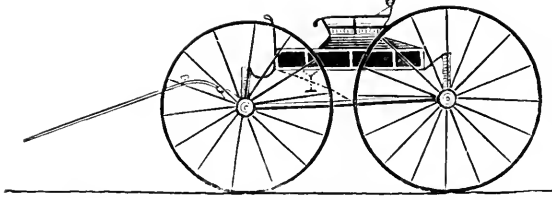

No. 2902C. 50 cts.

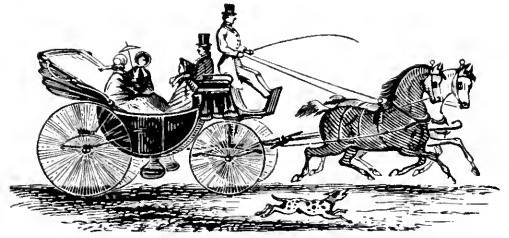

No. 2171C. 50 cts.

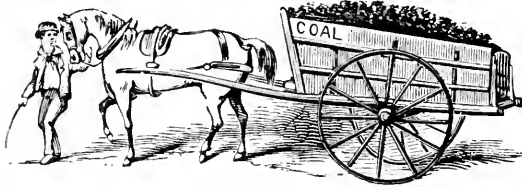

No. 4092C. 60 cts.

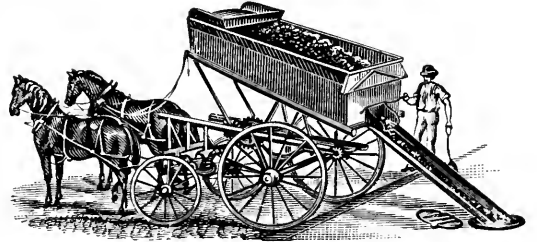

No. 182C. 15 cts.



No. 4093C. \$1.25

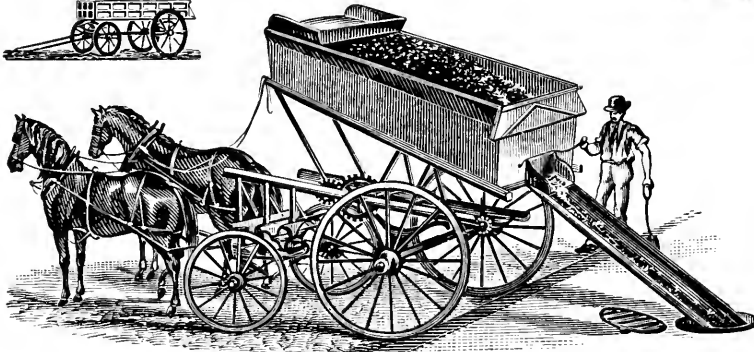

No. 4129F. 30 cts.



No. 466E. 15 cts.

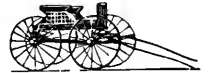

No. 4168C. 60 cts.

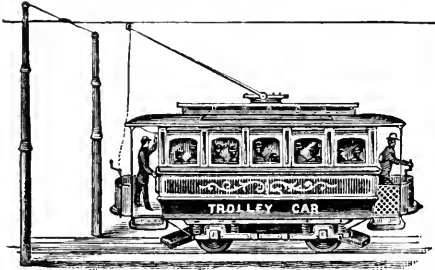

No. 2356C. 50 cts.



No. 4057F. 20 cts.



No. 717E. 25 cts.



No. 4167C. 40 cts.

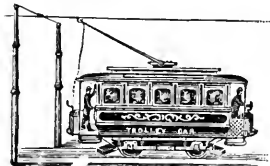

No. 2898C. Mortised. \$1.25



No. 2458C. 30 cts.



No. 265B. \$1.00



No. 4127C. 60 cts.



No. 3786C. 30 cts.



No. 2945C. 25 cts.



No. 3995C. 60 cts.



No. 850E. 30 cts.



No. 2662F. 25 cts.



No. 672E. 25 cts.



No. 2090E. 40 cts.



No. 3677C. 75 cts.



No. 2074E. 60 cts.



No. 1386D. 50 cts.

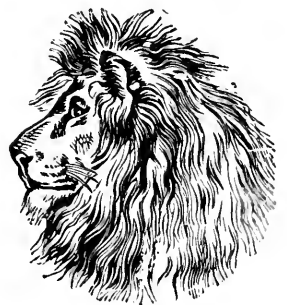

No. 2075E. \$1.00

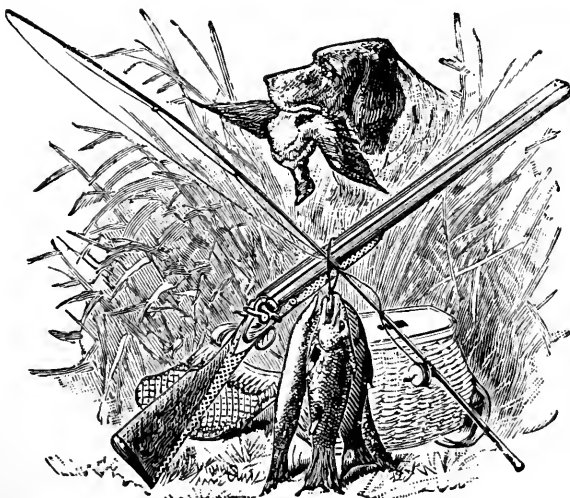

No. 3674C. 75 cts.



No. 2051E. 60 cts.



No. 2332C. 75 cts.



No. 2465C. 50 cts.



No. 4065F. 20c.



No. 2050E. 75 cts.

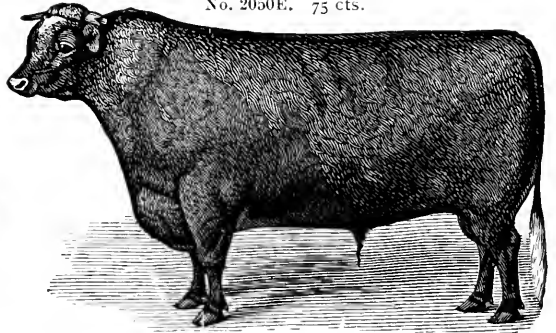

No. 616E. 15c.



No. 3756C. 75 cts.



No. 3094C. 60 cts.

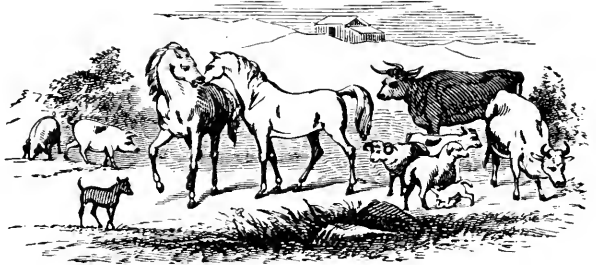

No. 2165C. \$1.00

No. 711E. 25c.



No. 709E. 25c.



No. 917E. 30c.



No. 2660F. 25c.



No. 731E. 25c.



No. 2657F. 20c.

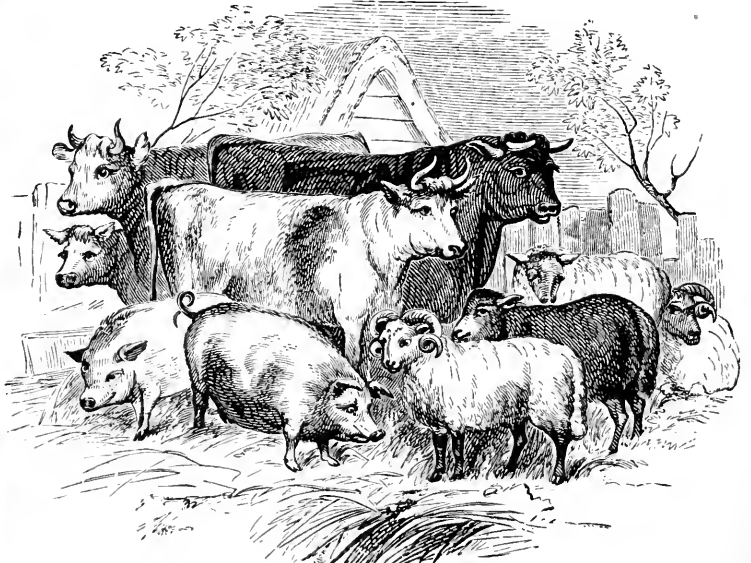

AMERICAN TYPE FOUNDERS COMPANY

No. 2053E. 75 cts.

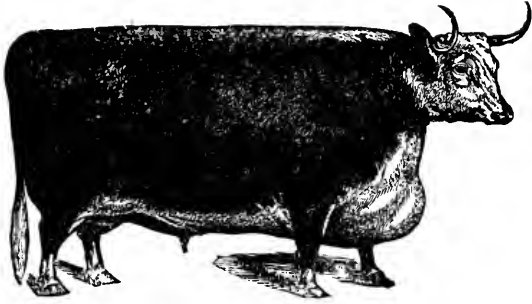

No. 2049E. 75 cts.

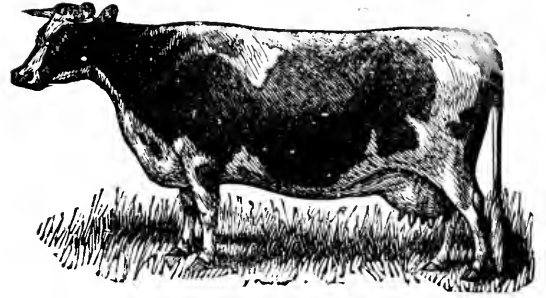

No. 3386C. \$1.00

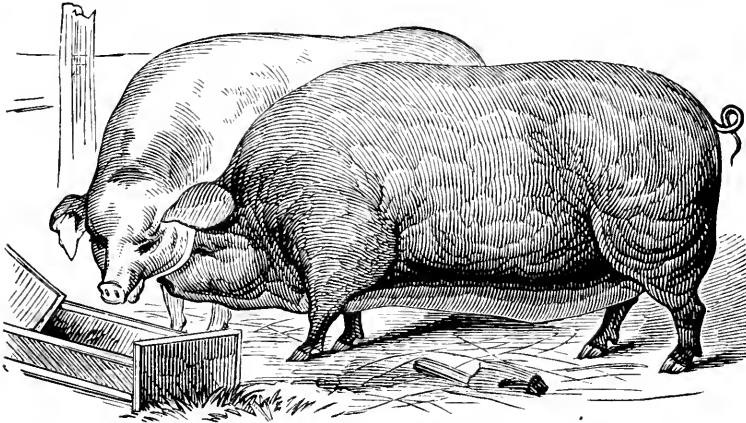

No. 3062C. 30 cts.

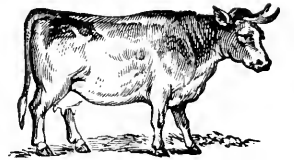

No. 3060C. 40 cts.

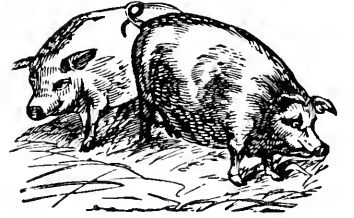

No. 1602D. 35 cts.



No. 1603D. 35 cts.

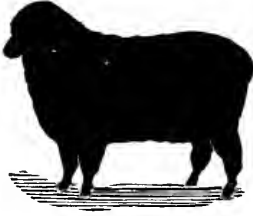

No. 1604D. 35 cts.

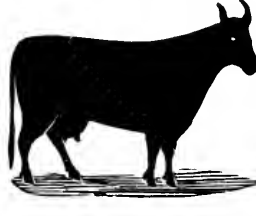

No. 1605D. 35 cts.

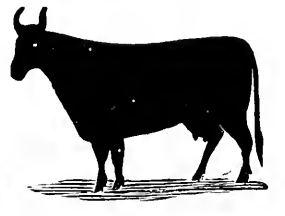

No. 1606D. 35 cts.

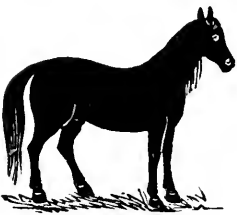

No. 1607D. 35 cts.

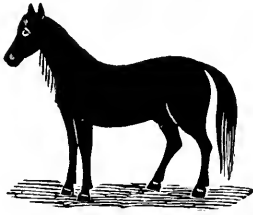

No. 1608D. 35 cts.



No. 1609D. 35 cts.



No. 1610D. 35 cts.



No. 1611D. 35 cts.



No. 1612D. 35 cts.

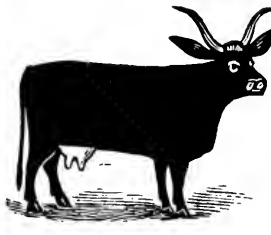

No. 1613D. 35 cts.



Cuts Nos. 1602D to 1613D, with Brands cut to order, 75 cents each.

AMERICAN TYPE FOUNDERS COMPANY

No. 4099F. 30 cents each; \$2.50 per dozen.

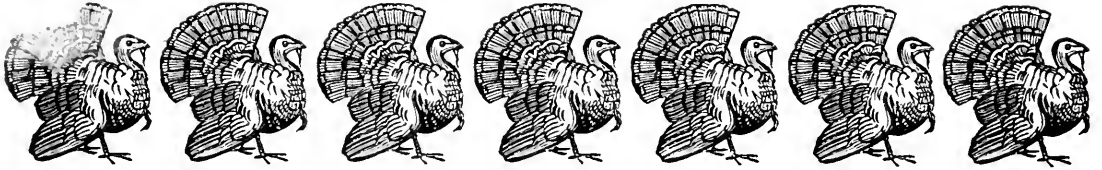

No. 3054C. \$1.00

No. 1750A. 35 cts.

No. 3055C. 40 cts.

No. 2048E. \$2.00



No. 3800C. 30 cts.

No. 1752A. 75 cts.

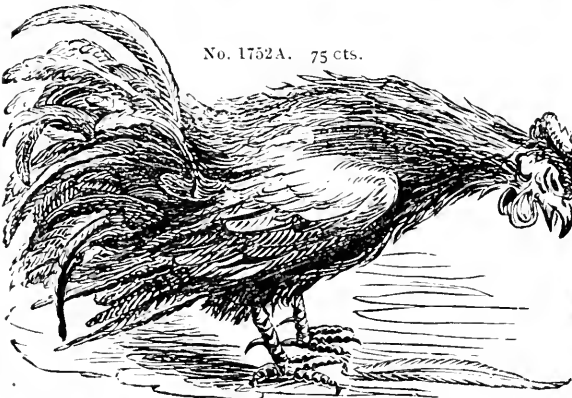

No. 4042F. 20 cents each; \$2.00 per dozen.

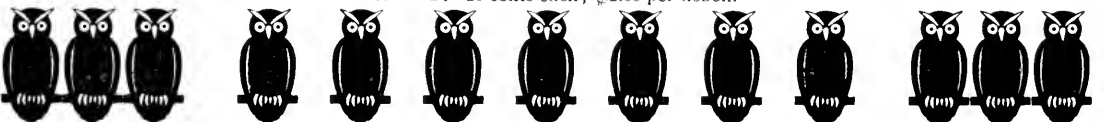

No. 4149F. 40 cents each; \$4.00 per dozen.

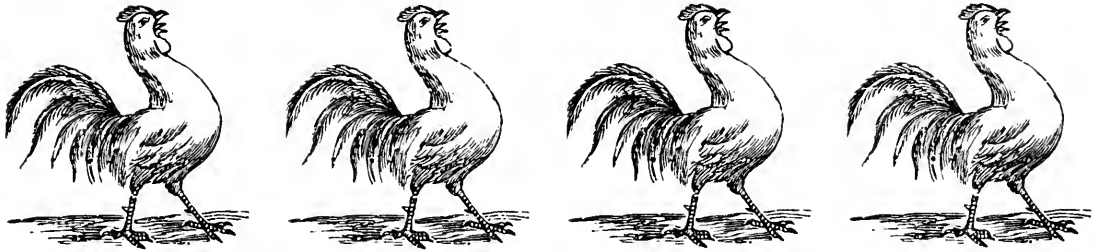

No. 2929C. 75 cts.

No. 3559B. 50 cts.

No. 2047E. 75 cts.



No. 859E. 30 cts.

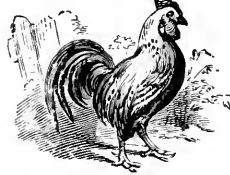

No. 2046E. 75 cts.



No. 3816C. \$1.00

No. 4099C. \$1.00

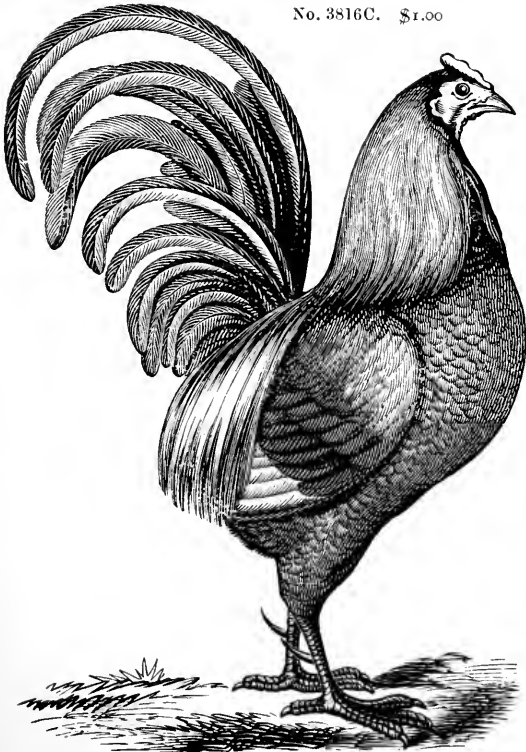

No. 2062E. 75 cts.

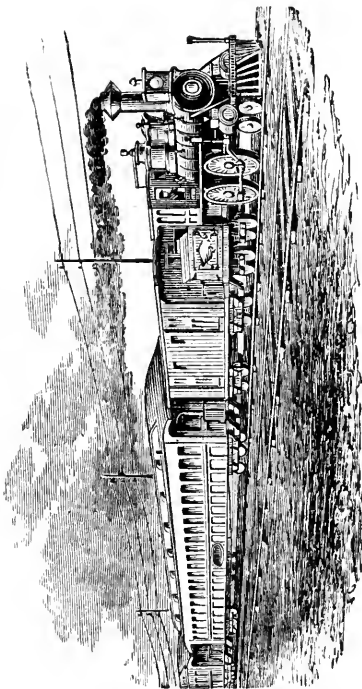

No. 2058E. 75 cts.

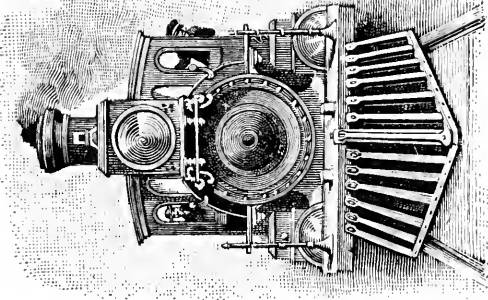

No. 3791C. 75 cts.

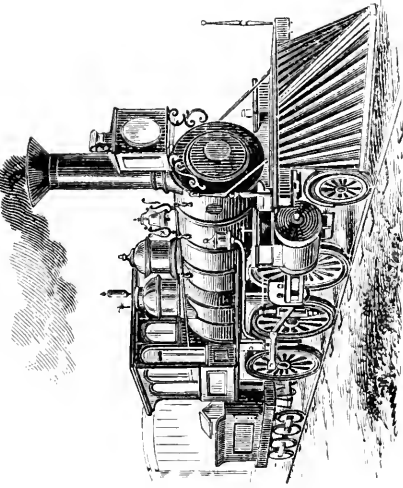

No. 3997C. 75 cts.

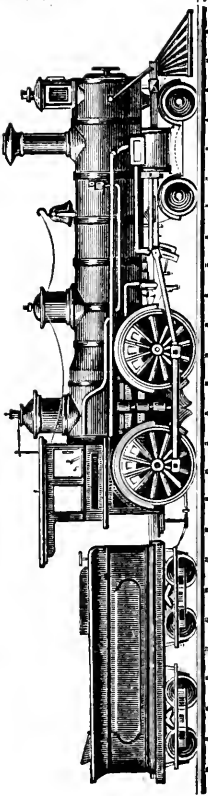

No. 3276C. 50 cts.

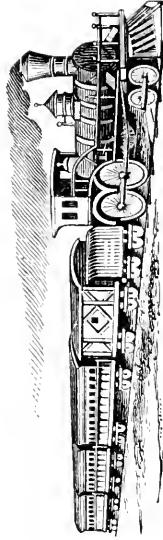

No. 2061E. 75 cts.

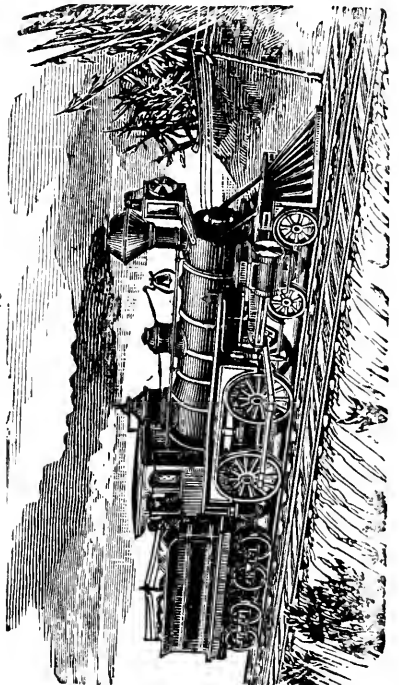

No. 2039E. Two Mortises. \$1.50

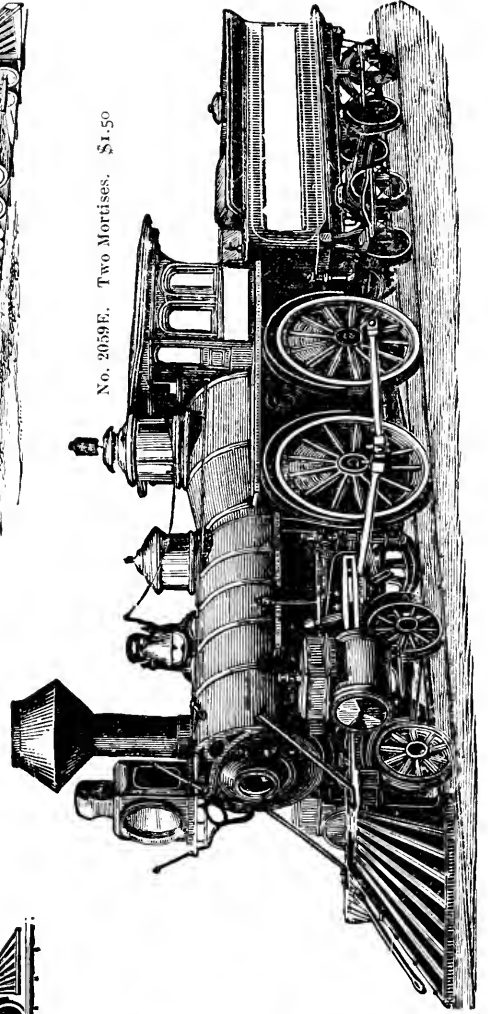

No. 2071E. \$1.00

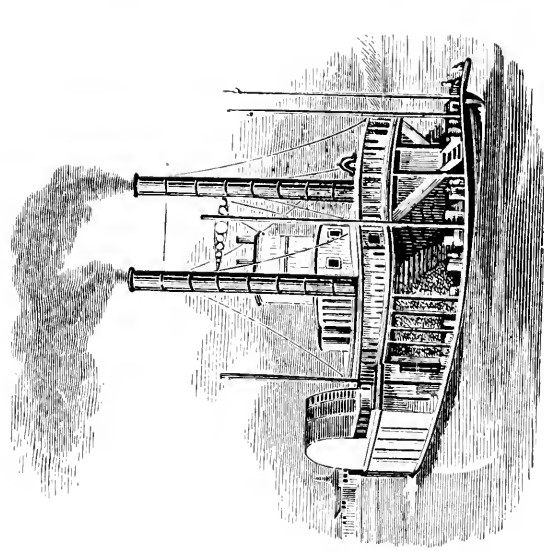

No. 2418C. 50 cts.

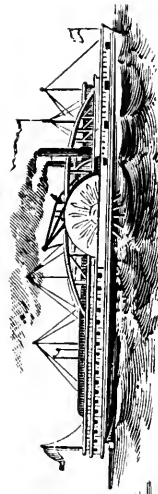

No. 3466C. 50 cts.

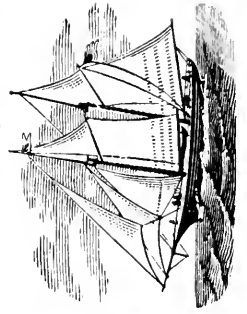

No. 2068E. \$1.00

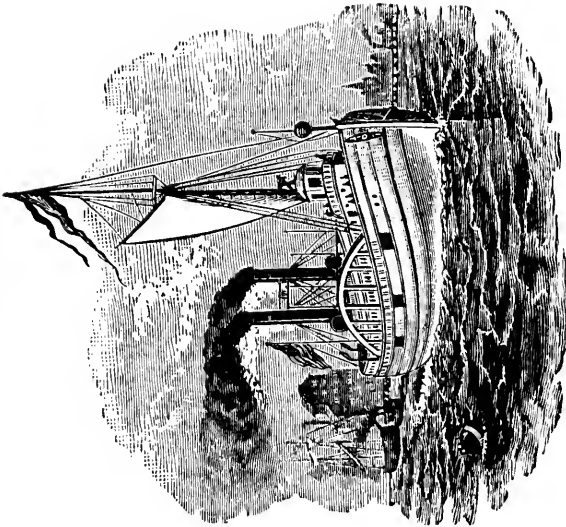

No. 2694C. 60 cts.

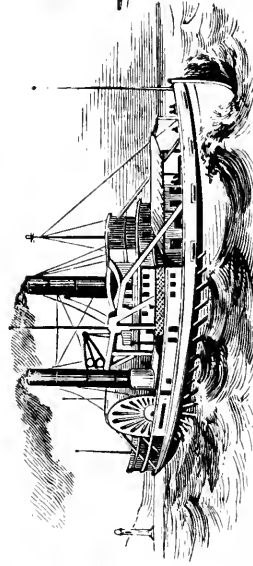

No. 2069E. 75 cts.

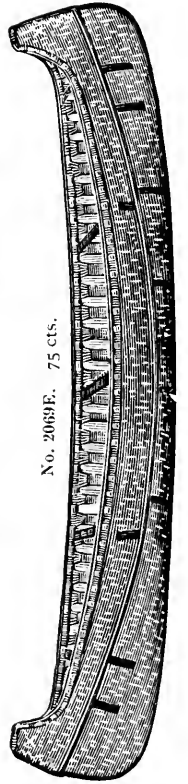

No. 2072E. 75 cts.

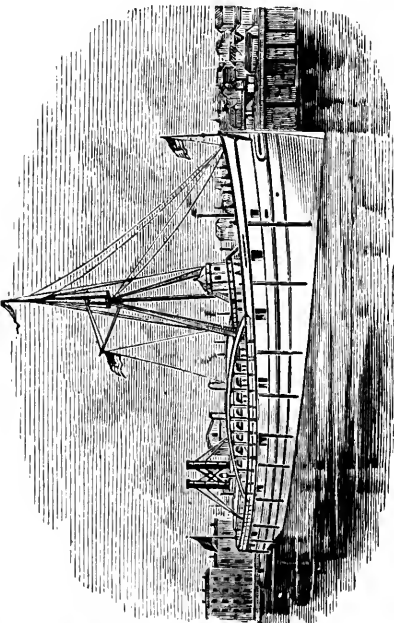

No. 2807C. 75 cts.

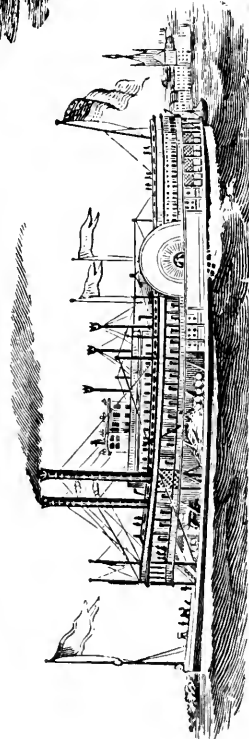

No. 3941C. 60 cts.

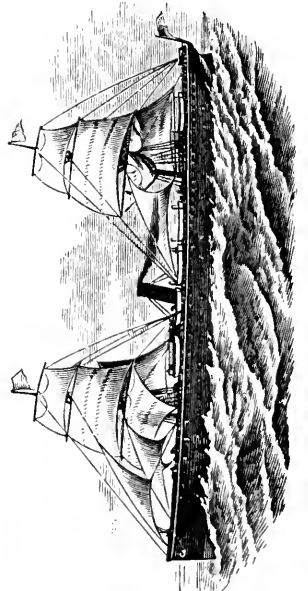

No. 4066C. 75 cts.



No. 4056C. 75 cts.



No. 4065C. 75 cts.

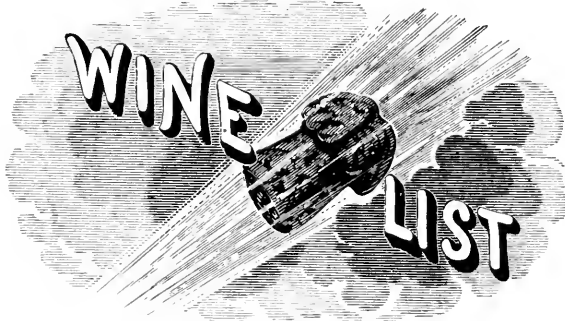

No. 4060C. 60 cts.

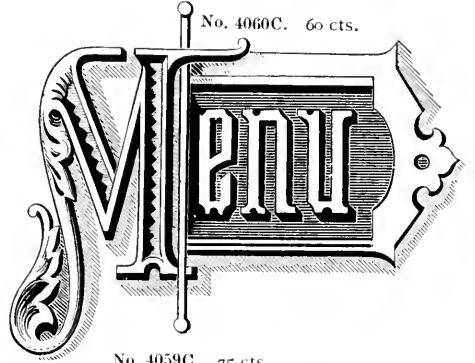

No. 4059C. 75 cts.



No. 4070C. 60 cts.



No. 4058C. 75 cts.



No. 4054C. 75 cts.



No. 4071C. 75 cts.



No. 4069C. 75 cts.



No. 4104C. 75 cts.



No. 4103C. 75 cts.

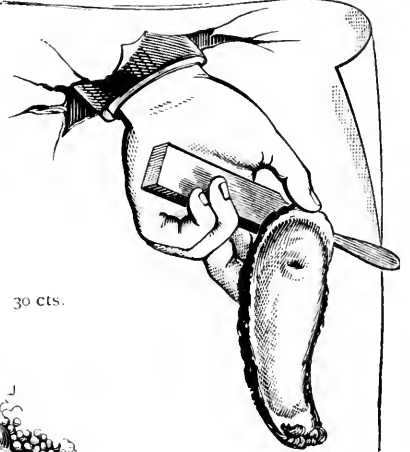

No. 3189C. 50 cts.



No. 2994C. 30 cts.



No. 2042C. 50 cts.

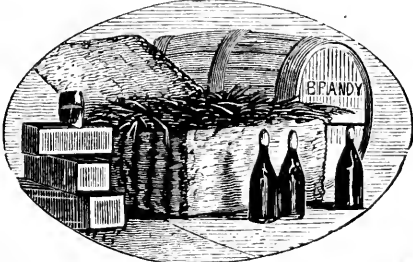

No. 2134C. 25 cts.



No. 3201C. 90 cts.



No. 652E. 20 cts.



No. 2285C. 40 cts.



No. 3190C. 60 cts.

No. 3792C. 75 cts.

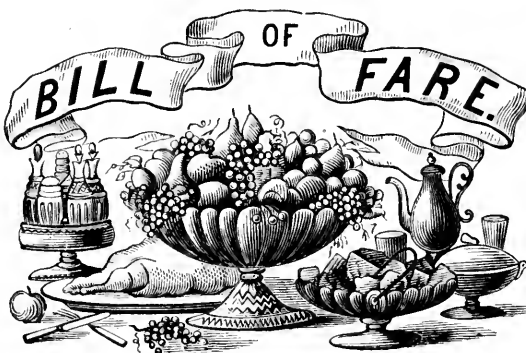

No. 3712C. 40 cts.



No. 3024C. 60 cts.



No. 3298C. 40 cts.

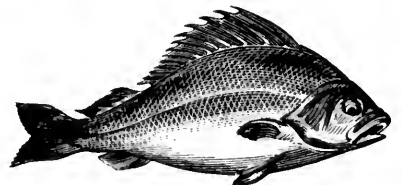

No. 4105C. 75 cts.

No. 4118C. 75 cts.

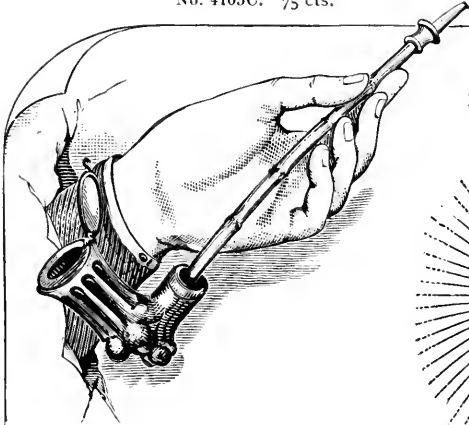

No. 275B. 50 cts.

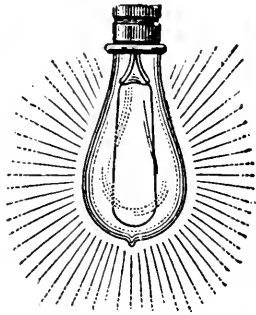

No. 272B. 35 cts.



No. 4106C. 75 cts.

No. 273B. 45 cts.

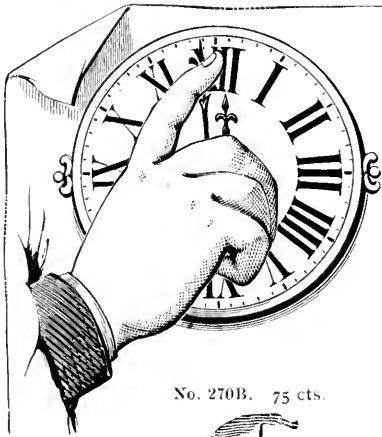

No. 271B. 50 cts.



No. 269B. 75 cts.

No. 270B. 75 cts.



No. 2891C. 50 cts.

No. 2749C. 45 cts.



No. 2302C. 50 cts.

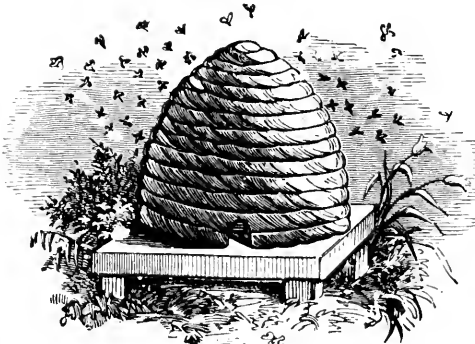

No. 4100C. 75 cts.

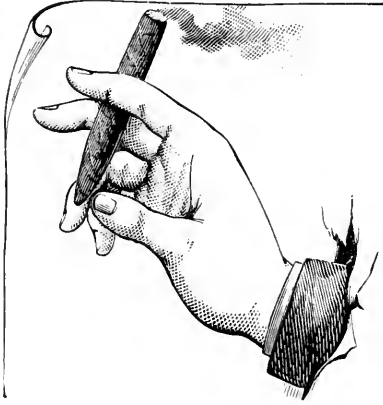

No. 3932D. 75 cts.

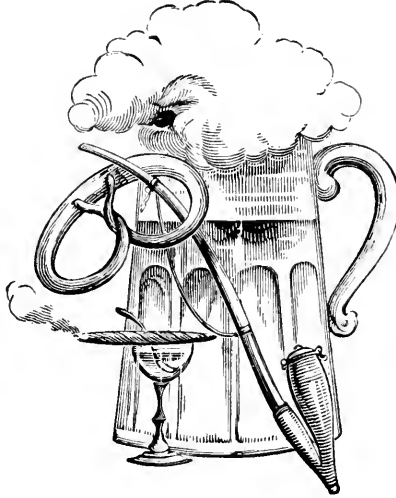

No. 4101C. 75 cts.

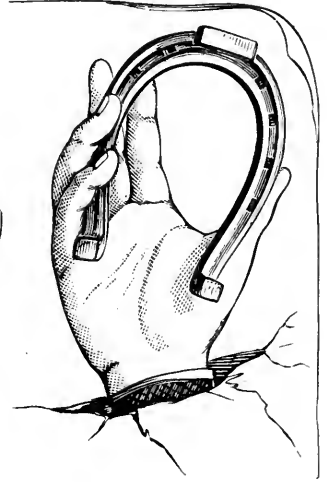

No. 2700C. Mortised. \$1.50



No. 5089C. 60 cts.



For four colors, \$2.00

No. 2253D. 60 cts.

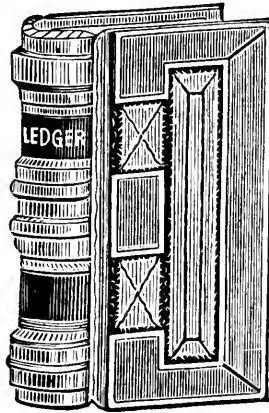

No. 1294D. 60 cts.

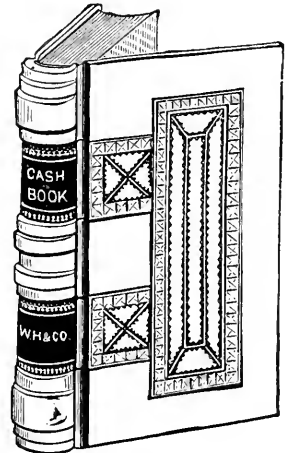

No. 3095C. 50 cts.

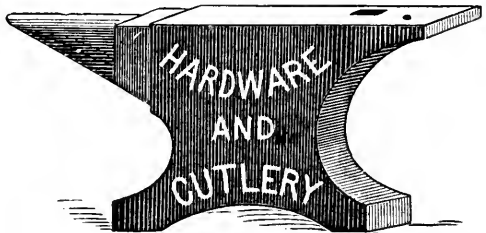

No. 4104C. 75 cts.



No. 4150C. 50 cts.

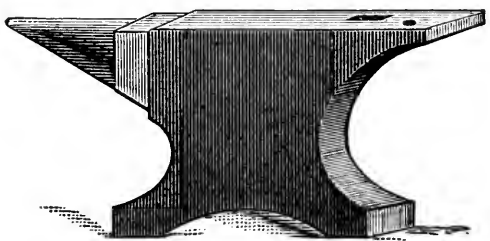

No. 3484C. Mortised. \$1.00

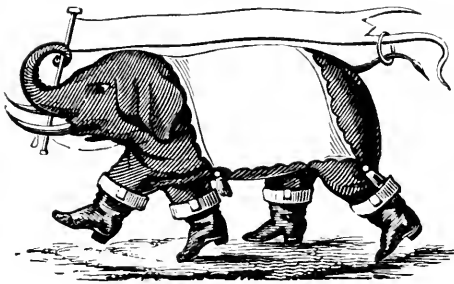

No. 4130C. 35 cts.

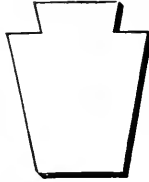

No. 4129C. 30 cts.



OTHER SIZES:

- No. 2825C. 2 1/2 x 1 1/2 inches \$1.25
- No. 2830C. 3 1/2 x 2 inches 1.50
- No. 2835C. 8 1/4 x 5 1/2 inches 3.50
- No. 2857C. 6 1/2 x 3 3/4 inches 2.50
- No. 3207C. 11 3/4 x 8 inches 5.50

OTHER SIZE:

- No. 2850C. 8 1/4 x 5 3/4 inches \$3.50

No. 2032E. 40 cts.



No. 3669C. 60 cts.

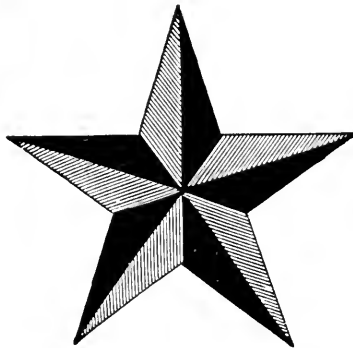

No. 3788C. 75 cts.

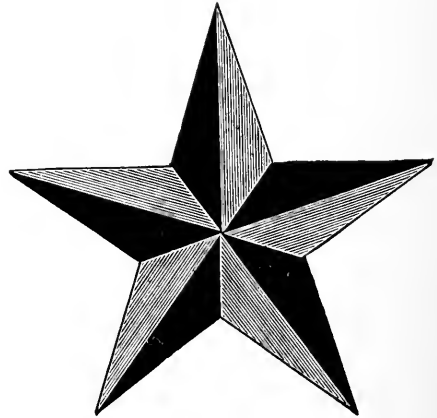

No. 3432C. 40 cts.



No. 3440C. 75 cts.
Mortised.



No. 4131C. 40 cts.

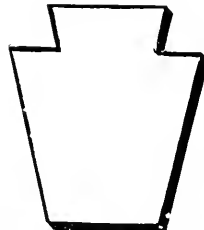

Mortised, extra, 30 cts.

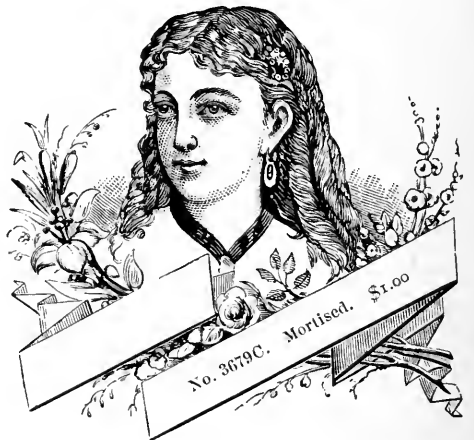

No. 2703C. Mortised.
\$1.00

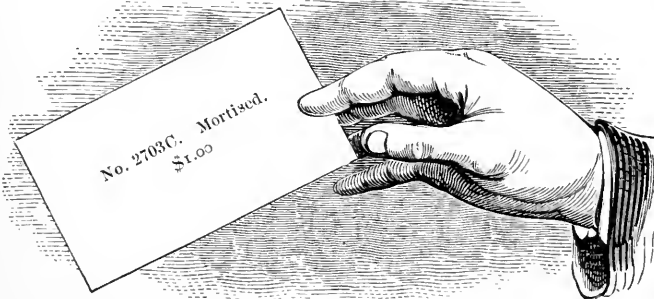

No. 2704C.
Mortised. 75 cts.

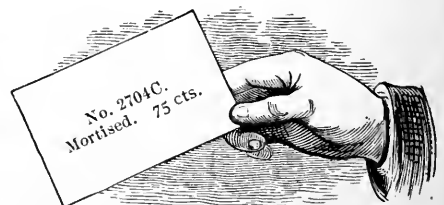

OTHER SIZE:—No. 3160C. 5 1/2 x 3 3/4 inches \$2.75

No. 4201C. 50 cts.

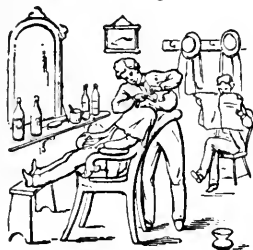

No. 4211C. 50 cts.



No. 4209C. 50 cts.



No. 4205C. 50 cts.



No. 3968C. 90 cts.



No. 3958C. 90 cts.



ELECTROTYPED OUTLINE FIGURES

FIRST SERIES. 30 cts. each

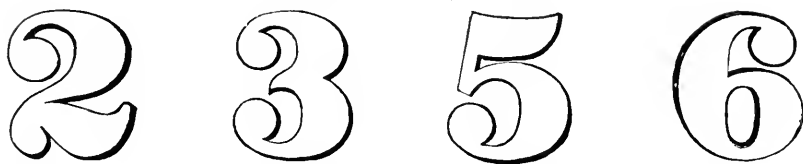

SECOND SERIES. 40 cts. each

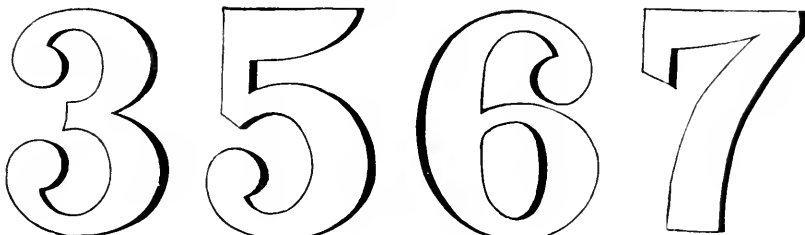

THIRD SERIES. 40 cts. each

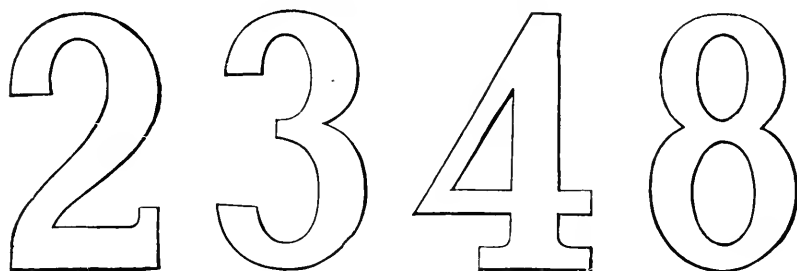

FOURTH SERIES. 50 cts. each



INDEX CUTS

No. 3846B. 30 cts.



No. 3847B. 30 cts.



No. 1052E
8 cts.



No. 1053E
8 cts.



No. 4015F. 20 cts.



No. 1078E. 30 cts.



No. 1079E. 30 cts.





No. 4016F. 20 cts.



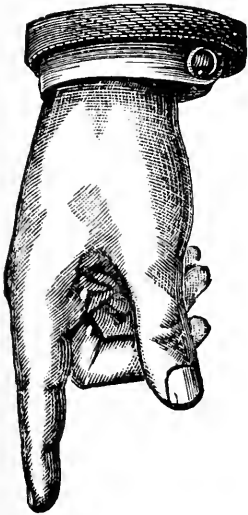



No. 3220A. 60 cts.



NEW INDEX CUTS

SIX POINT
514 515
 
5 cts. each

TEN POINT
518 519
 
8 cts. each



EIGHT POINT
516 517
 
6 cts. each



TWENTY-FOUR POINT

524

525

15 cts. each

TWELVE POINT
520 521
 
10 cts. each

EIGHTEEN POINT
522 523
 
12 cts. each

Per set (2 of each, right and left) \$1.50

No. 3218A. 60 cts.



No. 1072E. 12 cts.



No. 1074E. 20 cts.



No. 1075E. 20 cts.



No. 1073E. 12 cts.



No. 4018F. 25 cts.



No. 1070E. 15 cts.



No. 1071E. 15 cts.



No. 4017F. 25 cts.



No. 4013F. 15 cts.



No. 4012F. 10 cts.



No. 4009F. 10 cts.



No. 4007F. 10 cts.



No. 4005F. 5 cts.



No. 4006F. 5 cts.



No. 4008F. 10 cts.



No. 4010F. 10 cts.



No. 4011F. 10 cts.



No. 4014F. 15 cts.



No. 4001F. 5 cts.



No. 4003F. 5 cts.



No. 4004F. 5 cts.



No. 4002F. 5 cts.



INDEX CORNERS

COPYRIGHTED

No. 3986C.

No. 3987C.

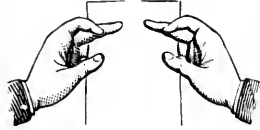

No. 3991C.

No. 3990C.



No. 3989C.

No. 3988C.



No. 3992C.

No. 3993C.

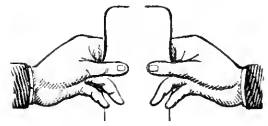

No. 4037C.

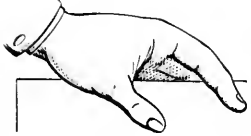

No. 4043C.



No. 4044C.



No. 4038C.

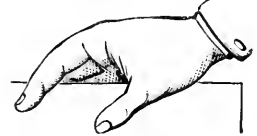

No. 4039C.

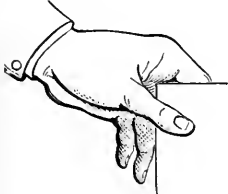

No. 4041C.

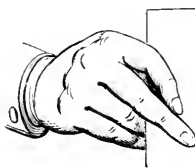

No. 4042C.

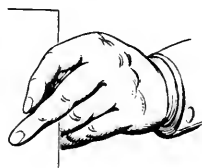

No. 4040C.

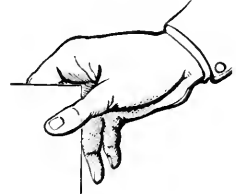

No. 4047C.

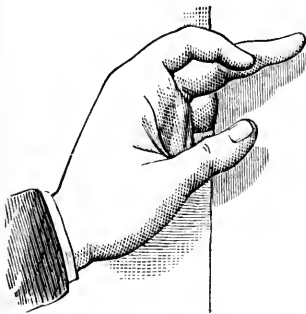

No. 4053C.

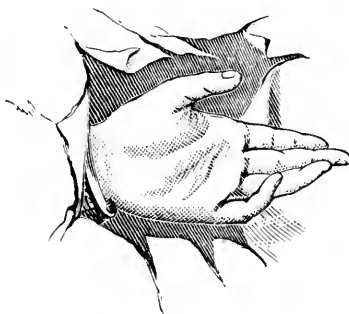

No. 4048C.

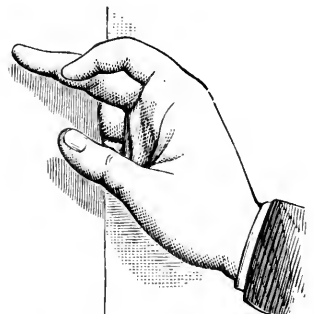

No. 4046C.



No. 4051C.



No. 4052C.



No. 4045C.



No. 4049C.

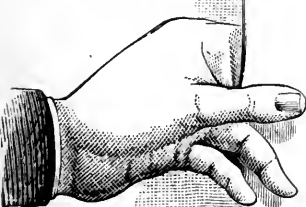

No. 4050C.

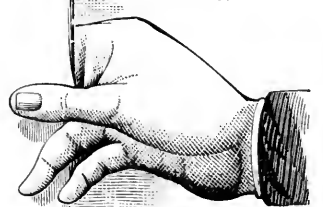

PRICES

| | |
|-------------------------------------|--------|
| Nos. 3986C to 3993C, set of eight . | \$1.75 |
| Single Corner | .25 |
| Nos. 4037C to 4044C, set of eight . | 2.50 |
| Single Corner | .35 |
| Nos. 4045C to 4052C, set of eight . | 3.50 |
| Single Corner | .50 |
| No. 4053C | .50 |

ELECTROTYPED ON SOLID METAL BODIES

HEAD AND TAIL PIECES

No. 4062A. \$1.50



No. 4210A. 75 cts.



No. 4038A. 60 cts.



No. 4207A. 60 cts.



No. 4012A. 60 cts.

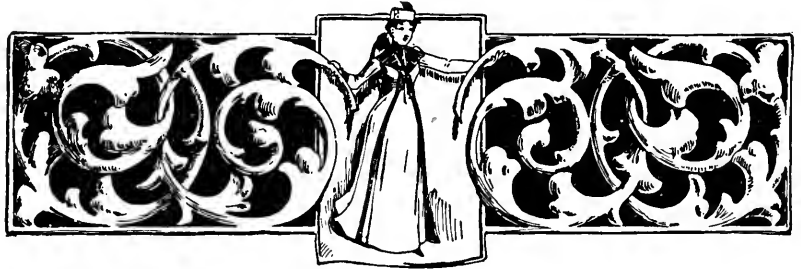

No. 4064A. 75 cts.

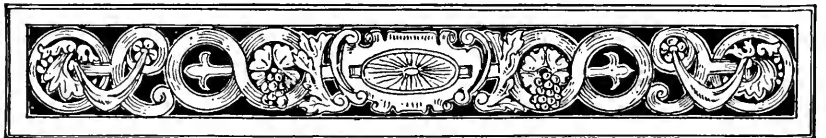

No. 4012A. 60 cts.

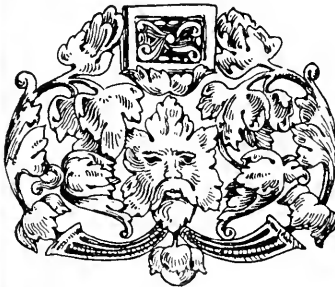

No. 4039A. 60 cts.



No. 4211A. 75 cts.



BRASS

Type for Bookbinders

Rules in Strips

Rules, Labor-Saving

Leaders, Hyphen and Dotted

Braces and Dashes

Slotted Corners

Circles and Ovals

ROUND CORNER RULE

PATENT APPLIED FOR

Put up in regular Labor Saving fonts with round corner pieces instead of the mitred corners usually sent

2 Point
3 lb. font **\$6.00**

4 Point
3 lb. font **\$5.25**

6 Point
5 lb. font **\$8.75**

2 Point

4 Point

6 Point

The large curve shows the top—the square corner shows the bottom of the rule—which is square inside up to quad height, giving a firm locking surface without shortening form at corners. Each piece is 6½ picas long and 18 points wide outside, which will be found a convenient size for both Newspaper and Job Work.

EXTRA CORNER PIECES

| | | | | |
|---------|-----------------|---|---|----------|
| 2 Point | per set of four | = | = | 50 cents |
| 4 | “ “ “ “ | = | = | 50 “ |
| 6 | “ “ “ “ | = | = | 50 “ |

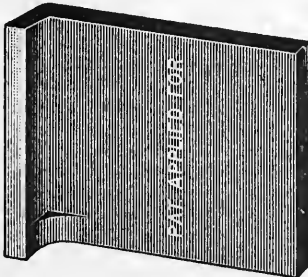

Offices not having new fonts of rule will find it less expensive to take the fonts above quoted. Not quite so much is charged for the corner pieces when included in the regular fonts as when purchased separately. The standard price is charged for the straight rule, the extra cost being for the corner pieces.

BRASS RULES

In ordering Brass Rules it is important to state both No. and Initial. Unless otherwise noted, Brass Rules are made in 24-inch strips

| No | BODY | PER FOOT |
|-------|----------|----------|
| 198 E | 1 Point | \$0 05 |
| 201 E | 1½ Point | 7½ |
| 203 E | 2 Point | 10 |
| 206 E | 3 Point | 15 |
| 207 E | 4 Point | 20 |
| 500 E | 5 Point | 25 |
| 208 E | 5½ Point | 27½ |
| 209 E | 6 Point | 30 |
| 210 E | 7 Point | 35 |
| 211 E | 8 Point | 40 |
| 212 E | 9 Point | 45 |
| 213 E | 10 Point | 50 |
| 214 E | 11 Point | 55 |
| 215 E | 12 Point | 60 |
| 216E | 1½ Point | 7½ |
| 526 E | 2 Point | 10 |
| 527 E | 2 Point | 10 |
| 501 E | 1½ Point | 7½ |
| 219E | 2 Point | 10 |
| 220E | 2 Point | 10 |
| 502 E | 2 Point | 10 |
| 503 E | 3 Point | 15 |
| 504 E | 4 Point | 20 |

| No | BODY | PER FOOT |
|-------|----------|----------|
| 505 E | 5 Point | \$0 25 |
| 506 E | 6 Point | 30 |
| 507 E | 7 Point | 35 |
| 508 E | 8 Point | 40 |
| 509 E | 9 Point | 45 |
| 510 E | 10 Point | 50 |
| 511 E | 11 Point | 55 |
| 512 E | 12 Point | 60 |
| 513 E | 1 Point | 5 |
| 514 E | 1½ Point | 7½ |
| 515 E | 2 Point | 10 |
| 516 E | 3 Point | 15 |
| 517 E | 4 Point | 20 |
| 518 E | 5 Point | 25 |
| 519 E | 6 Point | 30 |
| 520 E | 1½ Point | 7½ |
| 521 E | 2 Point | 10 |
| 522 E | 3 Point | 15 |
| 523 E | 4 Point | 20 |
| 524 E | 5 Point | 25 |
| 525 E | 6 Point | 30 |
| 528 E | 2 Point | 10 |
| 529 E | 3 Point | 15 |
| 530 E | 3 Point | 15 |
| 531 E | 6 Point | 30 |

For Labor-Saving Brass Rules, see pages 892 and 893

| No | BODY | PER FOOT |
|-------|----------|----------|
| 177E | 1 Point | \$0 05 |
| 180E | 1½ Point | 7½ |
| 182E | 2 Point | 10 |
| 185E | 3 Point | 15 |
| 187E | 4 Point | 20 |
| 189E | 5 Point | 25 |
| 190 E | 5½ Point | 27½ |
| 191E | 6 Point | 30 |
| 192E | 7 Point | 35 |
| 193E | 8 Point | 40 |
| 194E | 9 Point | 45 |
| 195E | 10 Point | 50 |
| 196E | 11 Point | 55 |
| 197E | 12 Point | 60 |
| 197½E | 18 Point | 90 |
| 339½E | 1½ Point | 7½ |
| 339E | 2 Point | 10 |
| 340½E | 1½ Point | 7½ |
| 340E | 2 Point | 10 |
| 341½E | 1½ Point | 7½ |
| 341E | 2 Point | 10 |
| 338½E | 2 Point | 10 |
| 342E | 2 Point | 10 |
| 343E | 2 Point | 10 |

| No | BODY | PER FOOT |
|-------|----------|----------|
| 234E | 2 Point | \$0 10 |
| 235E | 3 Point | 15 |
| 236E | 3 Point | 15 |
| 237E | 4 Point | 20 |
| 238E | 5 Point | 25 |
| 239E | 5½ Point | 27½ |
| 240E | 5½ Point | 27½ |
| 241E | 6 Point | 30 |
| 252E | 4 Point | 20 |
| 253E | 5 Point | 25 |
| 254E | 5½ Point | 27½ |
| 255E | 6 Point | 30 |
| 532 E | 4 Point | 20 |
| 533 E | 6 Point | 30 |
| 534 E | 6 Point | 30 |
| 245E | 3 Point | 15 |
| 246E | 5 Point | 25 |
| 247E | 5½ Point | 27½ |
| 262E | 3 Point | 15 |
| 263E | 4 Point | 20 |
| 264E | 5 Point | 25 |
| 265E | 5½ Point | 27½ |
| 266E | 6 Point | 30 |
| 267E | 7 Point | 35 |
| 268E | 8 Point | 40 |
| 269E | 9 Point | 45 |

For Labor-Saving Brass Rules, see pages 892 and 893

| No | BODY | PER FOOT |
|-------|----------|----------|
| 271E | 4 Point | \$0 20 |
| 272E | 4 Point | 20 |
| 273E | 5 Point | 25 |
| 274E | 5½ Point | 27½ |
| 275E | 6 Point | 30 |
| 276E | 7 Point | 35 |
| 277E | 7 Point | 35 |
| 281E | 3 Point | 15 |
| 282E | 4 Point | 20 |
| 283E | 5 Point | 25 |
| 284E | 6 Point | 30 |
| 285E | 6 Point | 30 |
| 286E | 7 Point | 35 |
| 287E | 8 Point | 40 |
| 288E | 10 Point | 50 |
| 289E | 11 Point | 55 |
| 290E | 12 Point | 60 |
| 290½E | 2 Point | 10 |
| 291E | 3 Point | 15 |
| 292E | 4 Point | 20 |
| 293E | 5 Point | 25 |
| 294E | 5½ Point | 27½ |
| 295½E | 5½ Point | 27½ |
| 296E | 6 Point | 30 |
| 297E | 6 Point | 30 |

| No | BODY | PER FOOT |
|------|----------|----------|
| 298E | 8 Point | \$0 40 |
| 299E | 9 Point | 45 |
| 301E | 10 Point | 50 |
| 302E | 11 Point | 55 |
| 304E | 12 Point | 60 |
| 305E | 18 Point | 90 |
| 312E | 5½ Point | 27½ |
| 313E | 5 Point | 25 |
| 314E | 7 Point | 35 |
| 316E | 8 Point | 40 |
| 317E | 9 Point | 45 |
| 319E | 5 Point | 25 |
| 320E | 5½ Point | 27½ |
| 321E | 5½ Point | 27½ |
| 322E | 7 Point | 35 |
| 323E | 8 Point | 40 |
| 324E | 10 Point | 50 |
| 325E | 12 Point | 60 |
| 326E | 5 Point | 25 |
| 327E | 5½ Point | 27½ |
| 328E | 7 Point | 35 |

For Labor-Saving Brass Rules, see pages 892 and 893

| No | BODY | PER FOOT |
|------|----------|----------|
| 329E | 8 Point | \$0 40 |
| 330E | 9 Point | 45 |
| 331E | 10 Point | 50 |
| 332E | 7 Point | 35 |
| 333E | 9 Point | 45 |
| 334E | 11 Point | 55 |
| 338E | 9 Point | 45 |
| 344E | 2 Point | 10 |
| 345E | 2 Point | 10 |
| 346E | 2 Point | 10 |
| 347E | 3 Point | 15 |
| 348E | 4 Point | 20 |
| 349E | 5½ Point | 27½ |
| 350E | 2 Point | 10 |
| 351E | 3 Point | 15 |
| 352E | 4 Point | 20 |
| 353E | 5½ Point | 27½ |
| 354E | 1½ Point | 7½ |
| 355E | 2 Point | 10 |
| 356E | 2 Point | 10 |
| 357E | 3 Point | 15 |
| 358E | 3 Point | 15 |
| 359E | 4 Point | 20 |
| 360E | 4 Point | 20 |
| 361E | 5½ Point | 27½ |
| 362E | 5½ Point | 27½ |

| No | BODY | PER FOOT |
|------|----------|----------|
| 363E | 2 Point | \$0 10 |
| 364E | 2 Point | 10 |
| 365E | 2 Point | 10 |
| 366E | 2 Point | 10 |
| 367E | 2 Point | 10 |
| 368E | 2 Point | 10 |
| 371E | 2 Point | 10 |
| 372E | 2 Point | 10 |
| 373E | 2 Point | 10 |
| 374E | 2 Point | 10 |
| 375E | 2 Point | 10 |
| 376E | 4 Point | 20 |
| 377E | 4 Point | 20 |
| 378E | 5½ Point | 27½ |
| 380E | 3 Point | 15 |
| 382E | 4 Point | 20 |
| 383E | 4 Point | 20 |
| 385E | 4 Point | 20 |
| 386E | 4 Point | 20 |
| 387E | 5½ Point | 27½ |
| 388E | 5½ Point | 27½ |
| 389E | 5½ Point | 27½ |
| 390E | 5½ Point | 27½ |
| 392E | 5½ Point | 27½ |
| 395E | 6 Point | 30 |

For Labor-Saving Brass Rules, see pages 892 and 893

| No | BODY | PER FONT |
|------|----------|----------|
| 396E | 5½ Point | \$0 27½ |
| 399E | 5½ Point | 27½ |
| 400E | 5½ Point | 27½ |
| 401E | 3 Point | 15 |
| 402E | 4 Point | 20 |
| 404E | 4 Point | 20 |
| 406E | 5½ Point | 27½ |
| 407E | 5½ Point | 27½ |
| 408E | 7 Point | 35 |
| 409E | 5½ Point | 27½ |
| 410E | 7 Point | 35 |
| 411E | 7 Point | 35 |
| 412E | 8 Point | 40 |
| 424E | 7 Point | 35 |
| 425E | 9 Point | 45 |
| 426E | 11 Point | 55 |
| 432E | 5½ Point | 27½ |
| 433E | 8 Point | 40 |
| 434E | 6 Point | 30 |
| 435E | 8 Point | 40 |
| 436E | 5 Point | 25 |
| 437E | 5 Point | 25 |

| No | BODY | PER FONT |
|-------|----------|----------|
| 438½E | 6 Point | \$0 30 |
| 439½E | 6 Point | 30 |
| 440½E | 6 Point | 30 |
| 441E | 8 Point | 40 |
| 442E | 8 Point | 40 |
| 443E | 10 Point | 50 |
| 444E | 4 Point | 20 |
| 445E | 8 Point | 40 |
| 447E | 4 Point | 20 |
| 448E | 6 Point | 30 |
| 449E | 10 Point | 50 |
| 450E | 4 Point | 20 |
| 452E | 10 Point | 50 |
| 454E | 9 Point | 45 |
| 455E | 5½ Point | 27½ |
| 456E | 4 Point | 20 |
| 457E | 5½ Point | 27½ |
| 280 B | 12 Point | 70 |
| 283 B | 18 Point | 90 |
| 284 B | 18 Point | 90 |

For Labor-Saving Brass Rules, see pages 892 and 893

| No | BODY | PER FOOT |
|-------|----------|----------|
| 286 B | 18 Point | 80 90 |
| 288 B | 18 Point | 90 |
| 290 B | 24 Point | 1 25 |
| 291 B | 24 Point | 1 25 |
| 297 B | 27 Point | 1 40 |
| 308 B | 2 Point | 12 |
| 309 B | 3 Point | 18 |
| 310 B | 4 Point | 22 |
| 311 B | 5 Point | 27 |
| 312 B | 6 Point | 32 |
| 313 B | 8 Point | 42 |
| 314 B | 12 Point | 65 |
| 324 B | 2 Point | 12 |
| 325 B | 3 Point | 18 |
| 326 B | 4 Point | 22 |
| 327 B | 5 Point | 27 |
| 328 B | 6 Point | 32 |
| 329 B | 8 Point | 42 |
| 330 B | 12 Point | 65 |

| No | BODY | PER FOOT |
|-------|----------|----------|
| 334 B | 2 Point | 80 12 |
| 335 B | 3 Point | 18 |
| 336 B | 4 Point | 22 |
| 337 B | 5 Point | 27 |
| 338 B | 6 Point | 32 |
| 339 B | 8 Point | 42 |
| 340 B | 12 Point | 65 |
| 342 B | 18 Point | 95 |
| 344 B | 2 Point | 12 |
| 345 B | 3 Point | 18 |
| 346 B | 4 Point | 22 |
| 347 B | 5 Point | 27 |
| 348 B | 6 Point | 32 |
| 349 B | 8 Point | 42 |
| 350 B | 12 Point | 65 |
| 352 B | 18 Point | 95 |
| 353 B | 24 Point | 1 25 |
| 405 B | 12 Point | 65 |
| 406 B | 18 Point | 95 |
| 407 B | 24 Point | 1 25 |

For Labor-Saving Brass Rules, see pages 892 and 893

| No | BODY | PER FOOT |
|-------|----------|----------|
| 362 B | 2 Point | \$0 12 |
| 363 B | 3 Point | 18 |
| 364 B | 4 Point | 22 |
| 365 B | 5 Point | 27 |
| 366 B | 6 Point | 32 |
| 367 B | 8 Point | 42 |
| 368 B | 12 Point | 65 |
| 369 B | 15 Point | 80 |
| 370 B | 18 Point | 95 |
| 371 B | 24 Point | 1 25 |
| 372 B | 2 Point | 12 |
| 373 B | 3 Point | 18 |
| 374 B | 4 Point | 22 |
| 375 B | 5 Point | 27 |
| 376 B | 6 Point | 32 |
| 377 B | 8 Point | 42 |
| 378 B | 12 Point | 65 |
| 379 B | 15 Point | 80 |
| 380 B | 18 Point | 95 |
| 381 B | 24 Point | 1 25 |

| No | BODY | PER FOOT |
|-------|----------|----------|
| 382 B | 2 Point | \$0 12 |
| 383 B | 3 Point | 18 |
| 384 B | 4 Point | 22 |
| 385 B | 5 Point | 27 |
| 386 B | 6 Point | 32 |
| 387 B | 8 Point | 42 |
| 388 B | 12 Point | 65 |
| 389 B | 15 Point | 80 |
| 390 B | 18 Point | 95 |
| 391 B | 24 Point | 1 25 |
| 566 B | 6 Point | 40 |
| 567 B | 8 Point | 50 |
| 568 B | 12 Point | 70 |
| 569 B | 15 Point | 90 |
| 570 B | 18 Point | 1 10 |
| 571 B | 24 Point | 1 25 |
| 572 B | 30 Point | 1 50 |
| 573 B | 36 Point | 1 80 |

For Labor-Saving Brass Rules, see pages 892 and 893

| No | BODY | PER FOOT |
|-------|----------|----------|
| 443 B | 2 Point | 80 12 |
| 444 B | 3 Point | 18 |
| 445 B | 4 Point | 22 |
| 446 B | 5 Point | 27 |
| 447 B | 6 Point | 32 |
| 448 B | 8 Point | 42 |
| 449 B | 12 Point | 65 |
| 453 B | 2 Point | 12 |
| 454 B | 3 Point | 18 |
| 455 B | 4 Point | 22 |
| 456 B | 5 Point | 27 |
| 457 B | 6 Point | 32 |
| 458 B | 8 Point | 42 |
| 459 B | 12 Point | 65 |
| 463 B | 2 Point | 12 |
| 464 B | 3 Point | 18 |
| 465 B | 4 Point | 22 |
| 466 B | 5 Point | 27 |
| 467 B | 6 Point | 32 |
| 468 B | 8 Point | 42 |
| 469 B | 12 Point | 65 |

| No | BODY | PER FOOT |
|-------|----------|----------|
| 470 B | 2 Point | 80 12 |
| 471 B | 3 Point | 18 |
| 472 B | 4 Point | 22 |
| 473 B | 5 Point | 27 |
| 474 B | 6 Point | 32 |
| 475 B | 8 Point | 42 |
| 476 B | 12 Point | 65 |
| 480 B | 2 Point | 12 |
| 481 B | 3 Point | 18 |
| 482 B | 4 Point | 22 |
| 483 B | 5 Point | 27 |
| 484 B | 6 Point | 32 |
| 485 B | 8 Point | 42 |
| 486 B | 12 Point | 65 |
| 490 B | 2 Point | 12 |
| 491 B | 3 Point | 18 |
| 492 B | 4 Point | 22 |
| 493 B | 5 Point | 27 |
| 494 B | 6 Point | 32 |
| 495 B | 8 Point | 42 |
| 496 B | 12 Point | 65 |

For Labor-Saving Brass Rules, see pages 892 and 893

| No | BODY | PER FOOT |
|-------|----------|----------|
| 500 B | 2 Point | \$0 12 |
| 501 B | 3 Point | 18 |
| 502 B | 4 Point | 22 |
| 503 B | 5 Point | 27 |
| 504 B | 6 Point | 32 |
| 505 B | 8 Point | 42 |
| 506 B | 12 Point | 65 |
| 507 B | 15 Point | 80 |
| 508 B | 18 Point | 95 |
| 509 B | 24 Point | 1 25 |
| 510 B | 2 Point | 12 |
| 511 B | 3 Point | 18 |
| 512 B | 4 Point | 22 |
| 513 B | 5 Point | 27 |
| 514 B | 6 Point | 32 |
| 515 B | 8 Point | 42 |
| 516 B | 12 Point | 65 |
| 587 B | 12 Point | 70 |
| 588 B | 24 Point | 1 25 |
| 589 B | 36 Point | 1 75 |

| No | BODY | PER FOOT |
|-------|----------|----------|
| 523 B | 2 Point | \$0 12 |
| 524 B | 3 Point | 18 |
| 525 B | 4 Point | 22 |
| 526 B | 5 Point | 27 |
| 527 B | 6 Point | 32 |
| 528 B | 8 Point | 42 |
| 529 B | 12 Point | 65 |
| 530 B | 15 Point | 80 |
| 531 B | 18 Point | 95 |
| 532 B | 24 Point | 1 25 |
| 533 B | 2 Point | 12 |
| 534 B | 3 Point | 18 |
| 535 B | 4 Point | 22 |
| 536 B | 5 Point | 27 |
| 537 B | 6 Point | 32 |
| 538 B | 8 Point | 42 |
| 539 B | 12 Point | 65 |
| 597 B | 12 Point | 70 |
| 598 B | 24 Point | 1 25 |
| 619 B | 6 Point | 40 |
| 620 B | 6 Point | 40 |

For Labor-Saving Brass Rules, see pages 892 and 893

| No | BODY | PER FOOT |
|-------|----------|----------|
| 590 B | 12 Point | \$0 70 |
| 591 B | 24 Point | 1 25 |
| 592 B | 36 Point | 1 80 |
| 593 B | 6 Point | 40 |
| 594 B | 12 Point | 70 |
| 595 B | 15 Point | 90 |
| 596 B | 24 Point | 1 25 |
| 980 F | 6 Point | 40 |
| 981 F | 8 Point | 50 |
| 982 F | 9 Point | 60 |
| 983 F | 10 Point | 65 |
| 984 F | 12 Point | 70 |
| 985 F | 15 Point | 90 |
| 986 F | 18 Point | 1 10 |
| 987 F | 24 Point | 1 25 |

| No | BODY | PER FOOT |
|--------|----------|----------|
| 599 B | 12 Point | \$0 70 |
| 600 B | 24 Point | 1 25 |
| 601 B | 36 Point | 1 80 |
| 615 B | 12 Point | 70 |
| 616 B | 24 Point | 1 25 |
| 617 B | 24 Point | 1 25 |
| 618 B | 24 Point | 1 25 |
| 980½ F | 6 Point | 40 |
| 981½ F | 8 Point | 50 |
| 982½ F | 9 Point | 60 |
| 983½ F | 10 Point | 65 |
| 984½ F | 12 Point | 70 |
| 985½ F | 15 Point | 90 |
| 986½ F | 18 Point | 1 10 |
| 987½ F | 24 Point | 1 25 |

Brass Rules with initial F are twelve inches long

| No | BODY | PER FOOT |
|--------|----------|----------|
| 988 F | 9 Point | \$0 60 |
| 989 F | 12 Point | 70 |
| 990 F | 15 Point | 90 |
| 991 F | 18 Point | 1 10 |
| 992 F | 24 Point | 1 25 |
| 993 F | 30 Point | 1 50 |
| 1036 F | 6 Point | 40 |
| 1037 F | 12 Point | 70 |
| 1038 F | 18 Point | 1 10 |
| 1039 F | 24 Point | 1 25 |
| 1040 F | 30 Point | 1 50 |

| No | BODY | PER FOOT |
|--------|----------|----------|
| 988½ F | 9 Point | \$0 60 |
| 989½ F | 12 Point | 70 |
| 990½ F | 15 Point | 90 |
| 991½ F | 18 Point | 1 10 |
| 992½ F | 24 Point | 1 25 |
| 993½ F | 30 Point | 1 50 |
| 1044 F | 9 Point | 60 |
| 1041 F | 12 Point | 70 |
| 1045 F | 18 Point | 1 10 |
| 1042 F | 24 Point | 1 25 |
| 1043 F | 36 Point | 1 75 |

Brass Rules with initial F are twelve inches long

PERFORATING RULES

| | | |
|--------------|-------------------|-------------------|
| 700E, Brass. | 2 Point. | Per foot, 15 cts. |
| 701E, Brass. | 3 Point. | Per foot, 18 cts. |
| 710E, Steel. | 17 teeth to 1 in. | Per foot, 50 cts. |
| 711E, Steel. | 12 teeth to 1 in. | Per foot, 50 cts. |
| 712E, Steel. | 8¼ teeth to 1 in. | Per foot, 50 cts. |

Steel Perforating Rule also put up in fonts containing 4 feet of Rule cut to Pica ems of assorted lengths. Price per font \$2.00

BRASS SCORING RULES

| | |
|-----------------------------|--------|
| 2 Point, per foot | \$0.10 |
| 3 Point, per foot | .15 |
| 4 Point, per foot | .20 |
| 6 Point, per foot | .30 |

BRASS SPACE RULE

Cut from 6 Point to 48 Point inclusive by half Picas (6 points). Can be furnished in ems of 7, 8, 9, 10 or 11 points, if desired.

| | Per lb. |
|--------------------|---------|
| 1 Point | \$3.50 |
| 1½ Point | 2.75 |
| 2 Point | 2.00 |

LABOR-SAVING BRASS RULE

Labor-saving Brass Rules are cut in length to 12 Point body, unless otherwise ordered, and are graduated by ens and ems. All fonts have mitred corner pieces. Special prices on application for Labor-saving Ornamental Brass Rules

NO 340E

2 POINT

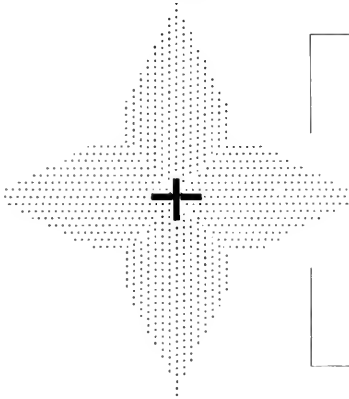

NO 203E

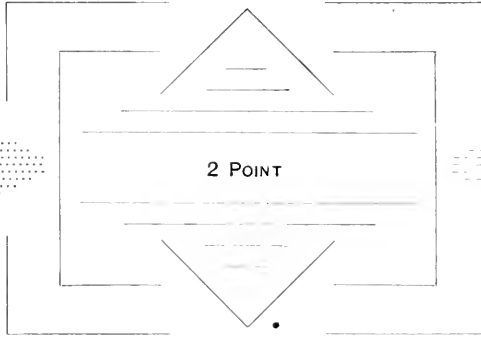

NO 341E

2 POINT

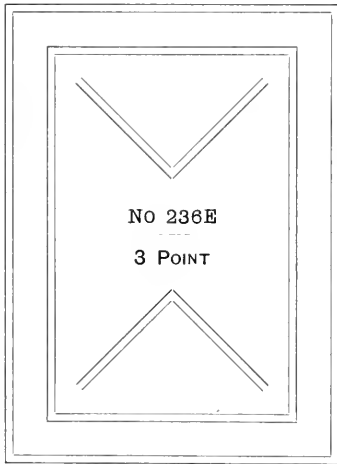
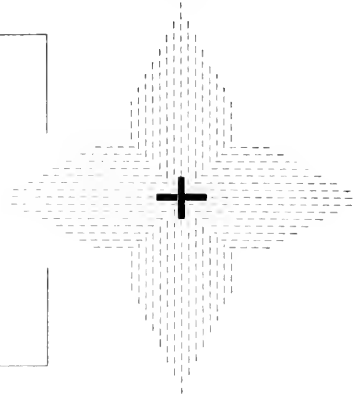

NO 219E
2 POINT

Prices of Labor-Saving Fonts

| PT | NO | 2-LB | 3-LB | 5-LB | 10-LB |
|----|-----|--------|--------|--------|---------|
| 2 | 203 | \$3 50 | \$5 25 | \$8 25 | \$16 50 |
| 2 | 219 | 3 50 | 5 25 | 8 25 | 16 50 |
| 2 | 340 | 3 50 | 5 25 | 8 25 | 16 50 |
| 2 | 341 | 3 50 | 5 25 | 8 25 | 16 50 |
| 3 | 236 | 3 20 | 4 80 | 7 50 | 15 00 |
| 3 | 281 | 3 20 | 4 80 | 7 50 | 15 00 |
| 4 | 237 | 3 00 | 4 50 | 7 00 | 14 00 |
| 6 | 285 | 3 00 | 4 50 | 7 00 | 14 00 |
| 6 | 297 | 3 00 | 4 50 | 7 00 | 14 00 |

In ordering add the initial "E" to the above Nos.

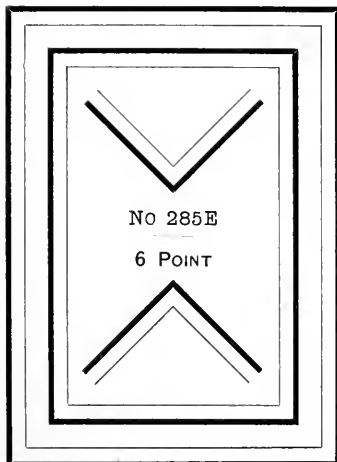
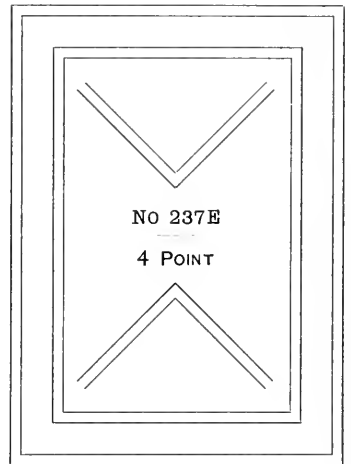

NO 281E
3 POINT

Price for Sorts
PER POUND

| | |
|-------------|------------|
| 1 Point | . . \$3 00 |
| 1 1/2 Point | . . 2 00 |
| 2 Point | . . 1 75 |
| 3 Point | . . 1 60 |
| 4 Point | . . 1 50 |
| 6 Point | . . 1 50 |
| 8 Point | . . 1 50 |
| 10 Point | . . 1 40 |

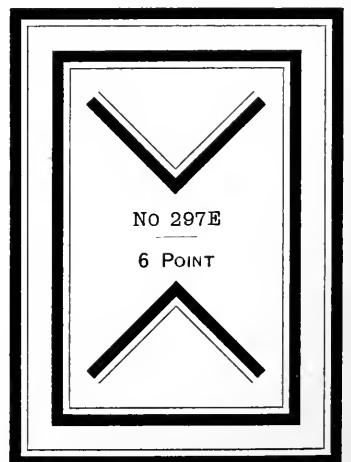

LABOR-SAVING BRASS RULE

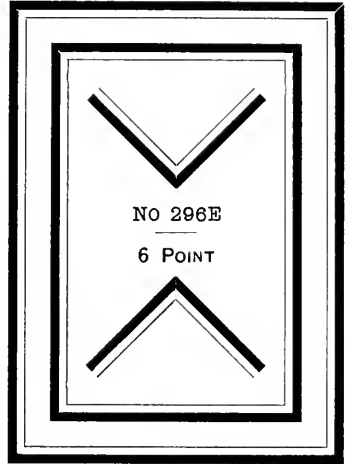
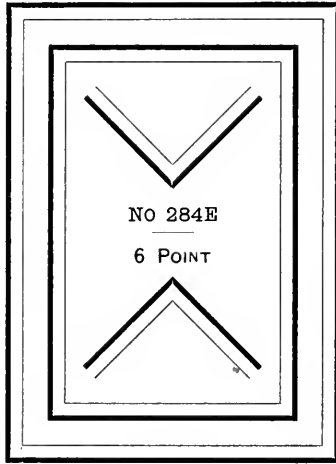
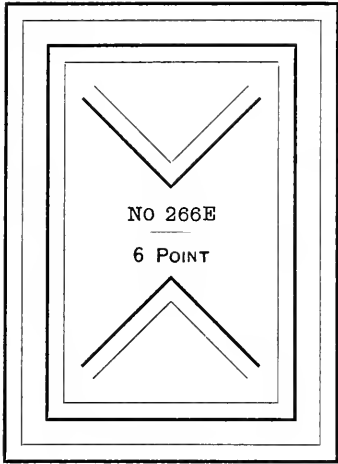

MITERED BRASS RULE.—Number of feet used is charged, less the discount, with extra charge for mitering as follows:
 6 Point Rule and under, 15 cents net per set of four miters
 Larger than 6 Point, 20 cents net per set of four miters

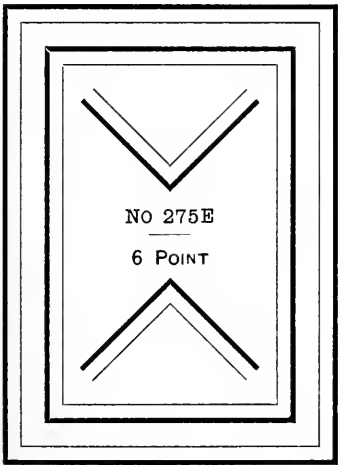

NO 282E
4 POINT

Prices of Labor-Saving Fonts

| PT | NO | 2-LB | 3-LB | 5-LB | 10-LB |
|----|-----|--------|--------|--------|---------|
| 4 | 282 | \$3 00 | \$4 50 | \$7 00 | \$14 00 |
| 4 | 292 | 3 00 | 4 50 | 7 00 | 14 00 |
| 6 | 266 | 3 00 | 4 50 | 7 00 | 14 00 |
| 6 | 275 | 3 00 | 4 50 | 7 00 | 14 00 |
| 6 | 284 | 3 00 | 4 50 | 7 00 | 14 00 |
| 6 | 296 | 3 00 | 4 50 | 7 00 | 14 00 |
| 8 | 287 | — | 4 50 | 7 00 | 14 00 |
| 10 | 288 | — | — | 7 00 | 13 50 |
| 10 | 301 | — | — | 7 00 | 13 50 |

In ordering add the initial "E" to the above Nos.

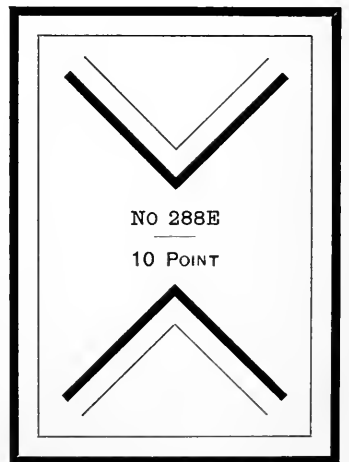
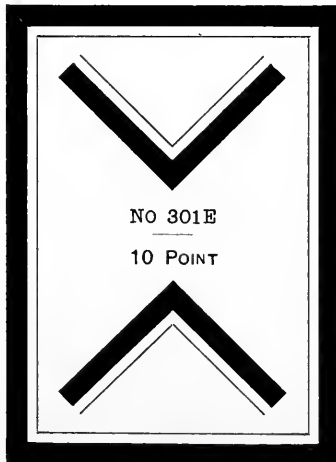
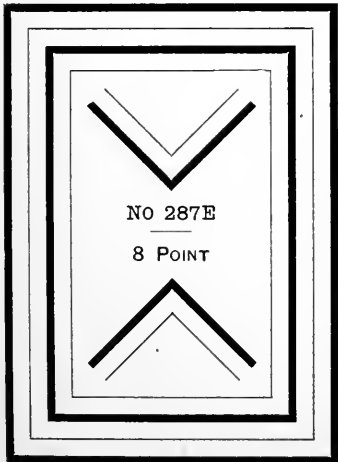
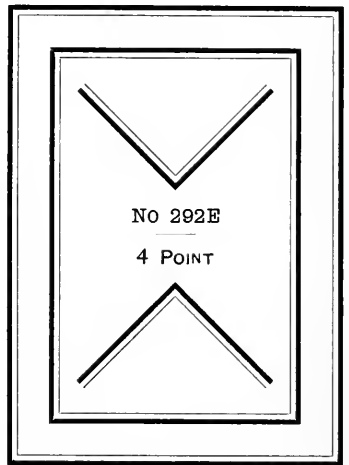

BRASS HEAD RULES [Ⓔ] *See table on next page for Standard Sizes of Head Rules*

The following prices are for any Single, Double, Parallel or Triple Rule shown in this book :

| BODY | 4-COL | 5-COL | 6-COL | 7-COL | 8-COL | 9-COL | BODY | 4-COL | 5-COL | 6-COL | 7-COL | 8-COL | 9-COL |
|-------------|--------|--------|--------|--------|--------|--------|-------------|--------|--------|--------|--------|--------|--------|
| 3 Point . . | \$0.15 | \$0.20 | \$0.25 | \$0.30 | \$0.30 | \$0.35 | 6 Point . . | \$0.25 | \$0.30 | \$0.35 | \$0.40 | \$0.45 | \$0.55 |
| 4 Point . . | .15 | .20 | .25 | .30 | .30 | .35 | 7 Point . . | .30 | .35 | .45 | .50 | .55 | .60 |
| 5 Point . . | .20 | .25 | .30 | .35 | .40 | .45 | 8 Point . . | .30 | .40 | .50 | .55 | .60 | .70 |
| 5½ Point . | .25 | .30 | .35 | .40 | .45 | .50 | | | | | | | |

| | |
|-----------|----------|
| No. 237E | 4 Point |
| No. 239E | 5½ Point |
| No. 241E | 6 Point |
| No. 282E | 4 Point |
| No. 273E | 5 Point |
| No. 274E | 5½ Point |
| No. 275E | 6 Point |
| No. 292E | 4 Point |
| No. 293E | 5 Point |
| No. 295½E | 5½ Point |
| No. 294E | 5½ Point |
| No. 296E | 6 Point |
| No. 277E | 7 Point |

ADVERTISING RULES [Ⓔ]

Prices quoted are for columns 15 Pica ems wide and under. For each additional width of column, add 50 per cent. to prices quoted below.

| | SINGLE COL. |
|----------|-------------|
| No. 203E | 4 cts. |
| No. 219E | 4 cts. |
| No. 364E | 5 cts. |
| No. 365E | 5 cts. |
| No. 366E | 5 cts. |
| No. 235E | 5 cts. |
| No. 236E | 6 cts. |
| No. 237E | 6 cts. |
| No. 273E | 6 cts. |

| | SINGLE COL. |
|-----------|-------------|
| No. 292E | 6 cts. |
| No. 293E | 6 cts. |
| No. 295½E | 6 cts. |
| No. 274E | 6 cts. |
| No. 275E | 6 cts. |
| No. 294E | 6 cts. |
| No. 296E | 6 cts. |

BRASS DASH RULES [Ⓔ]

Cut to single column width, not exceeding 15 Pica ems.

| | EACH |
|----------|--------|
| No. 203A | 6 cts. |
| No. 203B | 6 cts. |
| No. 203C | 6 cts. |
| No. 203D | 6 cts. |
| No. 219D | 6 cts. |
| No. 364D | 6 cts. |
| No. 237D | 8 cts. |
| No. 273D | 8 cts. |
| No. 293D | 8 cts. |

| | |
|----------|--------|
| No. 294D | 8 cts. |
| No. 219 | 6 cts. |
| No. 364 | 6 cts. |
| No. 237 | 8 cts. |
| No. 273 | 8 cts. |
| No. 293 | 8 cts. |
| No. 294 | 8 cts. |
| No. 367 | 8 cts. |

BRASS COLUMN RULES

6 PT. 7 PT. 8 PT.

9 PT. 10 PT.

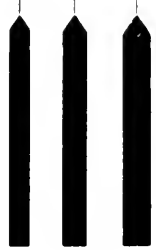

| SIZE | FACE LENGTH | 6 PT. | 7 PT. | 8 PT. | 9 PT. | 10 PT. |
|--------------------------------|-------------------------------------|--------|--------|--------|--------|--------|
| 4-Col. Folio or Quarto . . . | 13 ³ / ₄ ins. | \$0.40 | \$0.45 | \$0.50 | \$0.55 | \$0.60 |
| 5-Col. Folio or Quarto . . . | 17 ³ / ₄ ins. | .50 | .55 | .65 | .70 | .80 |
| 6-Col. Folio or Quarto . . . | 19 ³ / ₄ ins. | .55 | .60 | .70 | .80 | .85 |
| 7-Col. Folio or Quarto . . . | 21 ³ / ₄ ins. | .60 | .70 | .75 | .85 | .95 |
| 8-Col. Folio or Quarto . . . | 23 ³ / ₄ ins. | .65 | .75 | .85 | .95 | 1.05 |
| 9-Col. Folio | 25 ³ / ₄ ins. | .70 | .80 | .90 | 1.00 | 1.10 |
| Each additional inch | | .02 | .03 | .04 | .05 | .05 |

Column Rules nicked under for the use of Brass Reglet, 10 cents extra ; nicked under and over for Perfecting Presses, 25 cents each extra.

Labor-saving, 6, 7 and 8 Point, \$1.50 per lb. ; 9 and 10 Point, \$1.40 per lb.

Column Rules for Linotype Matter

| SIZE | 5x6 Point | 6x7 Point | 7x8 Point |
|--------------------|-----------|-----------|-----------|
| 6-Column | \$0.75 | \$0.85 | \$0.95 |
| 7-Column | .85 | .95 | 1.05 |
| 8-Column | .95 | 1.05 | 1.15 |

Either size, Labor-saving, \$2.00 per pound.

BRASS LEADS AND SLUGS

| BODY | Full Length | Cut Col. Measure | Cut L. S. |
|-------------------------------|-------------|------------------|-----------|
| 1-point, per pound | \$1.00 | \$1.00 | \$1.50 |
| 1½-point, per pound | .80 | .80 | 1.25 |
| 2-point, per pound | .75 | .75 | 1.25 |
| 6-pt., and thicker, per pound | .75 | .75 | 1.00 |

STANDARD SIZES OF NEWSPAPERS

This table of sizes is based upon the standard sizes of newspapers, with columns 13 12-point ems wide and 6-point column rules. The adoption of these sizes is advisable especially in starting newspapers or putting in new outfits, thereby gaining desirable uniformity.

| | Standard Size of Paper. | Size of Each Page. | * Face Length of 6-pt. Col. Rules. | Length of Head Rules required. |
|---------------------------|-------------------------|-------------------------------------|------------------------------------|---|
| | INCHES. | INCHES. | INCHES. | |
| 4-Column Quarto | 22 x 30 | 8 ¹ / ₂ x 14 | 13 ³ / ₄ | 53 ¹ / ₂ Pica ems. |
| 5-Column Quarto | 26 x 40 | 11 ¹ / ₂ x 18 | 17 ³ / ₄ | 67 Pica ems. |
| 6-Column Quarto | 30 x 44 | 13 ³ / ₄ x 20 | 19 ³ / ₄ | 80 ¹ / ₂ Pica ems. |
| 7-Column Quarto | 35 x 48 | 15 ³ / ₈ x 22 | 21 ³ / ₄ | 94 Pica ems. |
| 8-Column Quarto | 40 x 52 | 17 ¹ / ₈ x 24 | 23 ³ / ₄ | 107 ¹ / ₂ Pica ems. |
| 5-Column Folio | 20 x 26 | 11 ¹ / ₂ x 18 | 17 ³ / ₄ | 67 Pica ems. |
| 6-Column Folio | 22 x 30 | 13 ³ / ₈ x 20 | 19 ³ / ₄ | 80 ¹ / ₂ Pica ems. |
| 7-Column Folio | 24 x 35 | 15 ³ / ₈ x 22 | 21 ³ / ₄ | 94 Pica ems. |
| 8-Column Folio | 26 x 40 | 17 ¹ / ₈ x 24 | 23 ³ / ₄ | 107 ¹ / ₂ Pica ems. |
| 9-Column Folio | 28 x 44 | 20 ¹ / ₆ x 26 | 25 ³ / ₄ | 121 Pica ems. |

* Length of column rules for first page determined by size of headings, or say about two inches shorter than full length.

TABLE FOR NEWSPAPER ESTIMATES

Showing the number of ems of the different sizes of newspaper type in a line, the number of lines necessary to make one thousand ems, and the length in inches; the number of ems in the regular lengths of columns and the number of leads required. There are 66 13-em 2-point leads in one pound.

| ESTIMATED ON WIDTH OF STANDARD COLUMN, 13 EMS PICA. | 5½ POINT | 6 POINT | 7 POINT | 8 POINT | 9 POINT | 10 POINT | |
|---|--------------------------------|--------------------------------|--------------------------------|--------------------------------|--------------------------------|--------------------------------|------|
| Number ems in line | 28 ² / ₃ | 26 | 22 ¹ / ₄ | 19 ¹ / ₂ | 17 ¹ / ₃ | 15 ¹ / ₂ | |
| Number lines in 1000 ems | 35 ¹ / ₃ | 38 ¹ / ₂ | 45 | 51 ¹ / ₃ | 57 ² / ₃ | 64 ¹ / ₂ | |
| Number inches in 1000 ems | 2 ² / ₃ | 3 ¹ / ₄ | 4 ³ / ₈ | 5 ² / ₃ | 7 ¹ / ₄ | 9 | |
| 4-Column Folio or Quarto | } number ems { | 5040 | 4325 | 3175 | 2465 | 1950 | |
| 5-Column Folio or Quarto | | 6505 | 5615 | 4115 | 3200 | 2525 | 2085 |
| 6-Column Folio or Quarto | | 7180 | 6160 | 4515 | 3510 | 2770 | 2290 |
| 7-Column Folio or Quarto | | 7900 | 6785 | 4970 | 3865 | 3050 | 2520 |
| 8-Column Folio, number ems in column | 8630 | 7410 | 5440 | 4220 | 3330 | 2755 | |
| 9-Column Folio, number ems in column | 9310 | 8030 | 5885 | 4575 | 3615 | 2970 | |
| 2-point leads in 1000 ems of leaded matter | 26 | 29 | 35 | 41 | 47 | 54 | |
| 2-point leads in column, 4-column paper | 132 | 124 | 110 | 99 | 90 | 82 | |
| 2-point leads in column, 5-column paper | 170 | 160 | 142 | 128 | 116 | 107 | |
| 2-point leads in column, 6-column paper | 190 | 178 | 158 | 142 | 129 | 119 | |
| 2-point leads in column, 7-column paper | 209 | 196 | 174 | 157 | 142 | 131 | |
| 2-point leads in column, 8-column paper | 221 | 207 | 184 | 166 | 151 | 138 | |
| 2-point leads in column, 9-column paper | 266 | 250 | 222 | 200 | 182 | 167 | |
| Weight of 2-point leads in 1000 ems of leaded matter | 6 oz. | 7 oz. | 8½ oz. | 10 oz. | 11½ oz. | 13 oz. | |
| Weight of 2-point leads needed to lead 1000 ems of solid matter | 8½ oz. | 9½ oz. | 11 oz. | 12½ oz. | 14 oz. | 16 oz. | |

BRASS DASHES

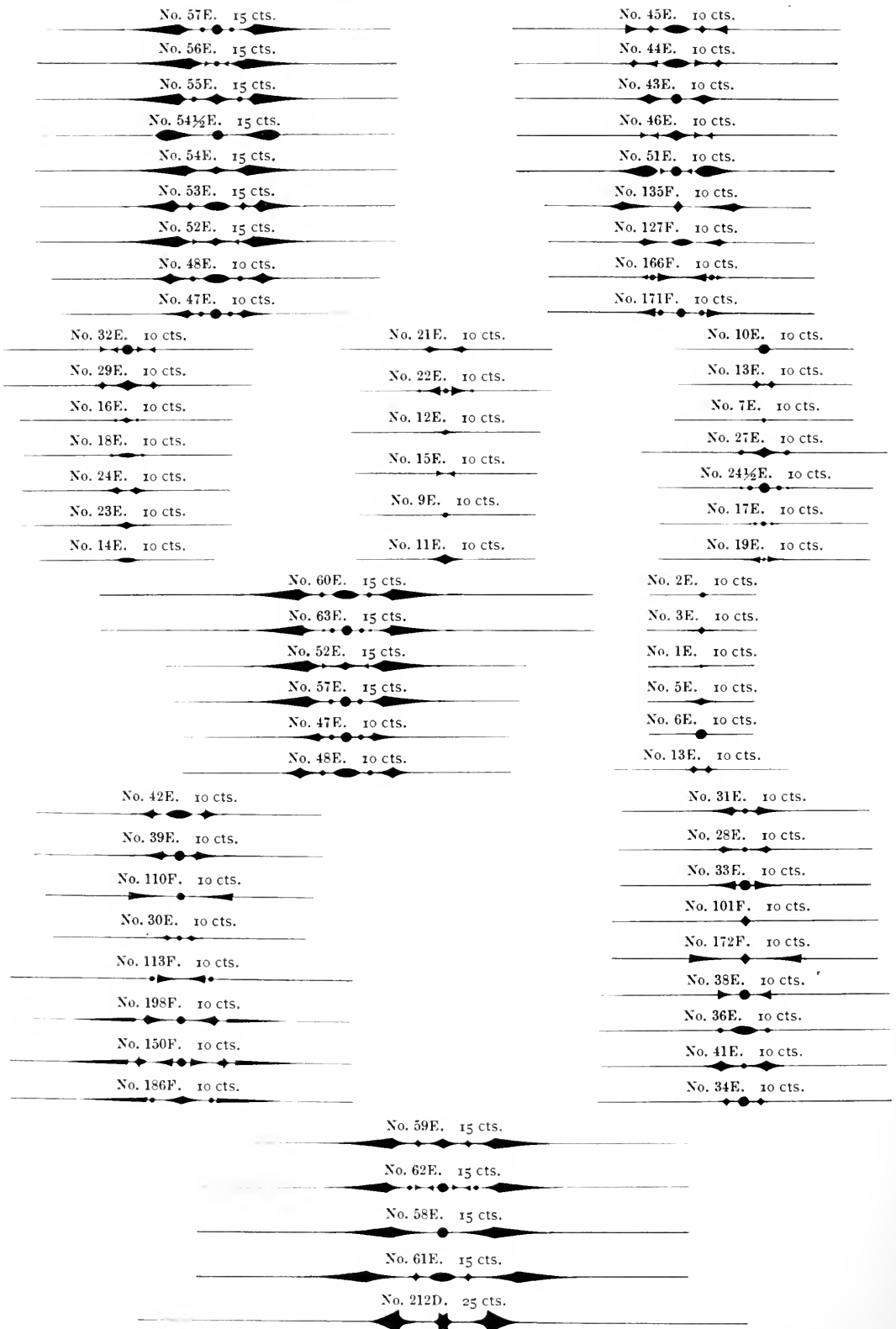

All Brass Dashes that are sold for 10 cents each supplied any length for News Columns not exceeding 15 ems Pica

BRASS BRACES

COMPLETE SET \$5 60

c

No. 32. 30 cts.

No. 31. 30 cts.

No. 30. 30 cts.

No. 29. 30 cts.

No. 28. 30 cts.

No. 27. 25 cts.

No. 26. 25 cts.

No. 25. 25 cts.

No. 24. 25 cts.

No. 23. 25 cts.

No. 22. 18 cts.

No. 21. 18 cts.

No. 20. 18 cts.

No. 19. 18 cts.

No. 18. 18 cts.

No. 17. 15 cts.

No. 16. 15 cts.

No. 15. 15 cts.

No. 14. 15 cts.

No. 13. 15 cts.

No. 38. 12 cts.

No. 37. 12 cts.

No. 36. 12 cts.

No. 35. 12 cts.

No. 34. 12 cts.

No. 33. 12 cts.

No. 1. 12 cts.

No. 2. 12 cts.

No. 3. 12 cts.

No. 4. 12 cts.

No. 5. 12 cts.

No. 6. 12 cts.

No. 7. 12 cts.

No. 8. 12 cts.

No. 9. 12 cts.

No. 10. 12 cts.

No. 11. 15 cts.

No. 12. 15 cts.

c

The superiority of a Brace cut out of solid Brass to one electrotyped from these Brass Braces is obvious, and those who furnish electrotyped Braces charge quite as much for them as we charge for these original Brass Braces.

LABOR-SAVING BRASS LEADERS

| | Style | | | | Style | | |
|----------------|-------|-------|-------|---|----------------|-------|-------|
| | 6 | 7 | 8 | | 6 | 7 | 8 |
| 5 Point body. | | | | Style No. 6, 7 or 8, from 12 Points to 216 Points in length Per lb. 5 Point . \$1 60 5½ Point . 1 60 6 Point . 1 60 7 Point . 1 60 8 Point . 1 60 9 Point . 1 50 10 Point . 1 50 11 Point . 1 40 12 Point . 1 40 | 9 Point body. | | |
| 5½ Point body. | | | | | 10 Point body. | | |
| 6 Point body. | | | | | 11 Point body. | | |
| 7 Point body. | | | | | 12 Point body. | | |
| 8 Point body. | | | | | | | |

To avoid possibility of error, it is safer to send cap H and lower-case m of the face with which the leaders are to be used, and state which style of leader is wanted.

BRASS CIRCLES

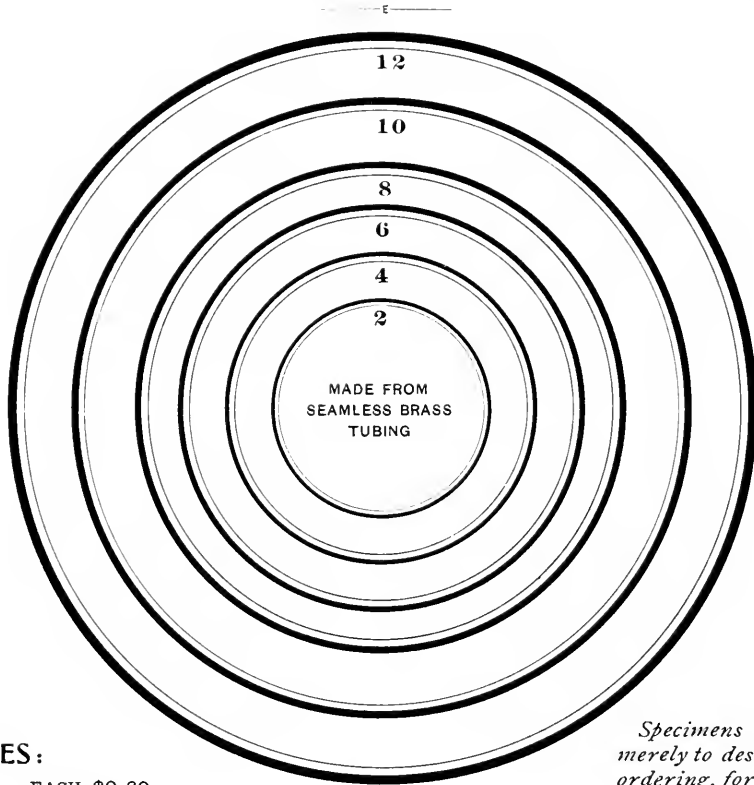

PRICES:

| | | |
|-------------------------|------|--------|
| NOS. 1 TO 6 | EACH | \$0.60 |
| NOS. 7 TO 9 | EACH | 0.75 |
| NOS. 10 TO 12 | EACH | 1.00 |
| NO. 13 | EACH | 1.25 |

Specimens on this page are merely to designate Sizes. In ordering, for Size give the No. attached to Specimen, and for the Face give the No. from Specimens of Brass Rule in this book

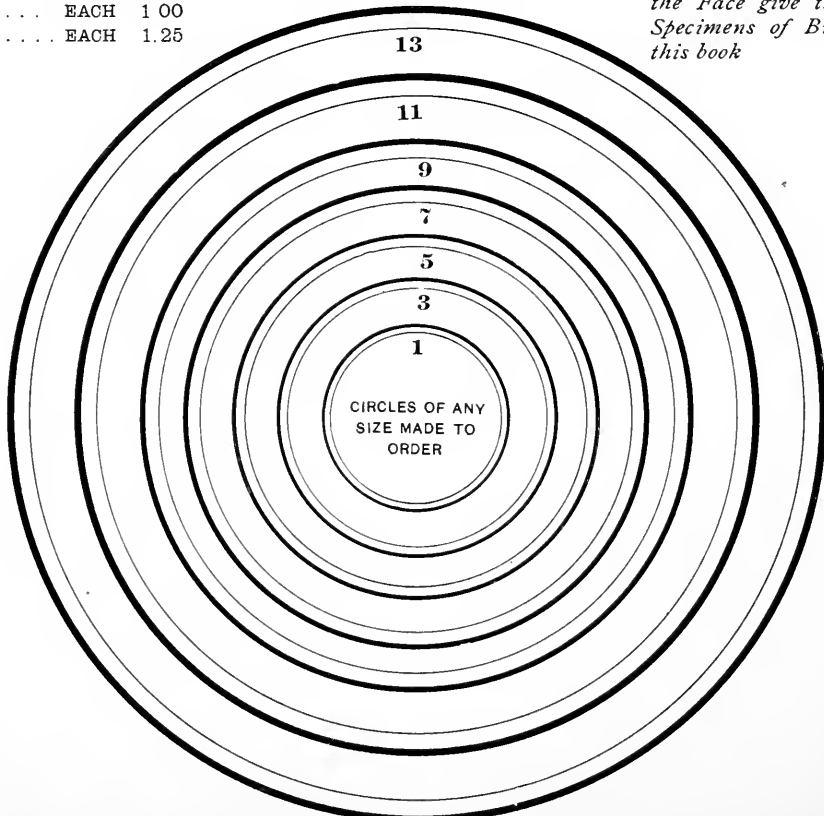

BRASS CIRCLES, DIAMONDS AND OVALS

Specimens on this page are merely to designate Sizes. In ordering, for Size give the No. attached to Specimen, and for the Face give the No. from Specimens of Brass Rule in this book

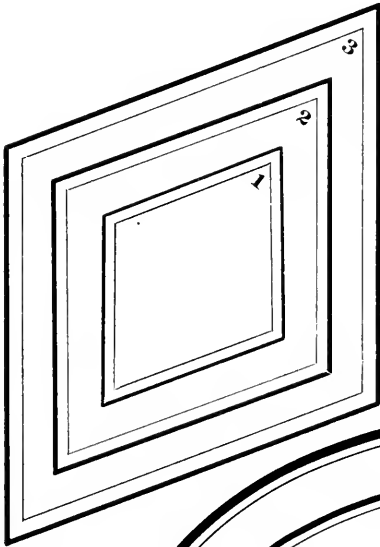
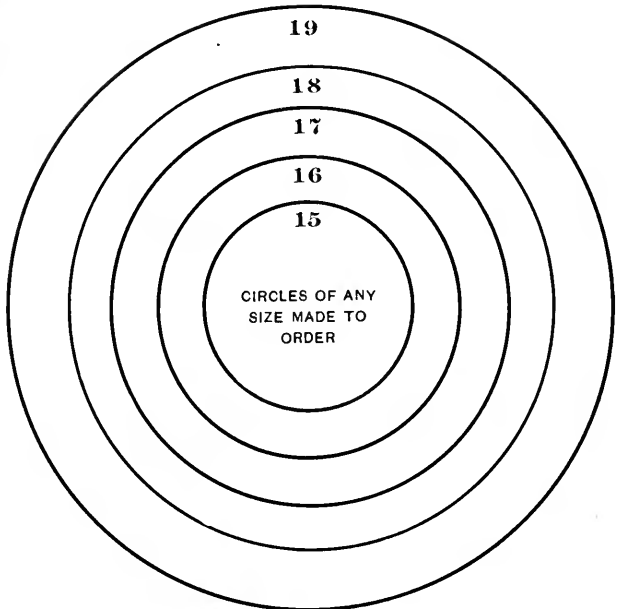
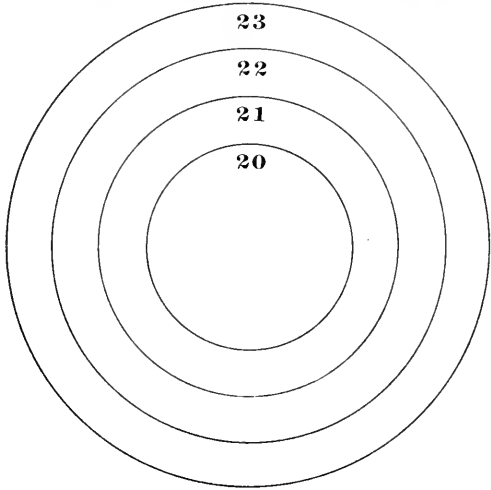

| CIRCLES | |
|-----------------------|--------|
| NOS. | EACH |
| 15 TO 17 AND 20 TO 22 | \$0.60 |
| 18 AND 23 | .75 |
| 19 | 1.00 |

| DIAMONDS | |
|---------------|------|
| 1 AND 2 | .75 |
| 3, 5, 6 AND 7 | 1.00 |

| OVALS | |
|------------------|------|
| 4, 5 AND SMALLER | .90 |
| 6 AND 7 | 1.25 |

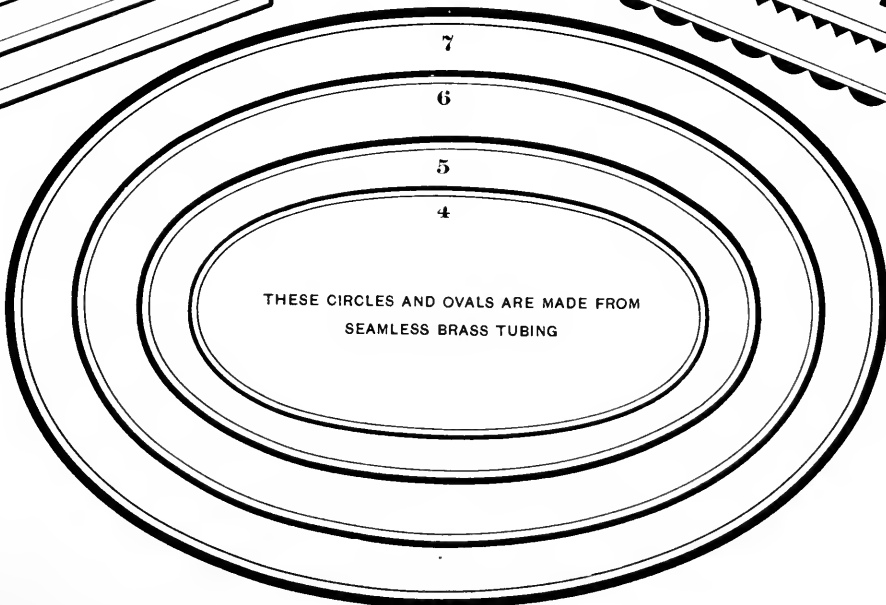
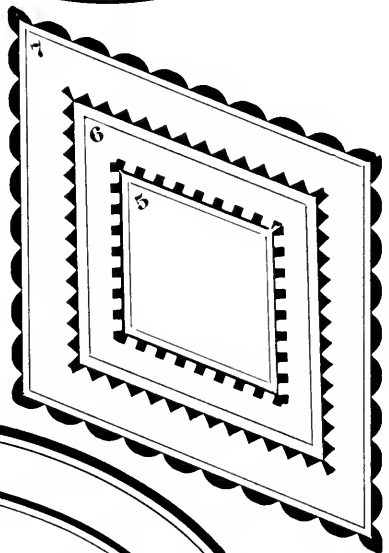

Brass Type for Bookbinders

BRASS TYPE AND BORDERS AND ORNAMENTS

A special Specimen Book of Brass Type will be sent on application. The following series, or parts of them, shown in this Specimen Book, are made in Solid Brass :

| | PAGE |
|---|----------|
| Antique Condensed Nos. 122 and 116 (Caps) | 553, 563 |
| Antique Extra Condensed No. 150 (Caps) . . . | 559 |
| Antique No. 125 (Caps) | 558 |
| Art Gothic | 387 |
| Atlanta | 375 |
| Condensed Aldine No. 150 (Caps) | 519 |
| Condensed No. 124 | 522 |
| Edinburgh Title | 501 |
| Facade | 391 |
| French Old Style No. 1 | 504 |
| Gothic Condensed No. 124 (Caps) | 615 |
| Gothic Extra Condensed No. 150 (Caps) | 611 |
| Gothic No. 127 | 620 |
| Lafayette (Caps) | 357 |
| Latin Antique No. 120 (Caps) | 557 |
| Latin Condensed No. 150 (Caps) | 394 |
| Modern Antique (Caps) | 554, 555 |
| Modern Text No. 40 | 642 |
| Mural | 390 |
| Norman Condensed | 423 |
| Novelty Script | 220 |
| Old Style Bold (Caps) | 508 |
| Old Style Extended (Caps) | 507 |
| Old Style No. 43 | 502 |
| Two-Line No. 124 | 523 |
| Two-Line No. 151 | 521 |
| Victoria | 376 |
| Yonkers | 636 |

Also, a Collection of Forty-five Beautiful Borders and
Thirty-nine Word Ornaments

PART XIX.

Wood Type

WOOD TYPE.

The series shown in this Specimen Book are selected from our Complete Specimen Book of Wood Type, which will be forwarded on application. It contains the most up-to-date, and also all the standard, styles of Wood Type, Borders and Ornaments.

Wood Type is priced by the letter, and sold in various sized fonts, as under. Font orders are subject to a liberal discount; small sort orders are subject to a smaller discount than is allowed on fonts. For prices and schemes of 4A and 5A fonts, see our Specimen Book of Wood Type.

- 3A cap font contains 75 letters.
- 3a lower-case font contains 65 letters.
- 4A cap font contains 106 letters.
- 4a lower-case font contains 90 letters.
- 5A cap font contains 120 letters.
- 5a lower-case font contains 104 letters.

Figures are put up separately.

Customers should bear in mind that End-Wood Type can be made any size desired. A wood-type letter increases in width in exactly the same proportion as it does in length. For example: If a 12-line letter is 2 inches wide, the same letter in 15-line will be 2½ inches wide, the increase being one-quarter each way.

Scheme of 3A 3a font with figures.

| Caps. 75 Letters | Lower Case 65 Letters | Figs. and Points. |
|------------------------|--------------------------------|-------------------------|
| A -3 | a -3 | 1 -3 |
| B -2 | b -2 | 2 -2 |
| C -2 | c -2 | 3 -2 |
| D -2 | d -2 | 4 -2 |
| E -4 | e -4 | 5 -2 |
| F -2 | f -2 | 6 -2 |
| G -2 | g -2 | 7 -2 |
| H -2 | h -2 | 8 -2 |
| I -4 | i -3 | 9 -2 |
| J -2 | j -1 | 0 -5 |
| K -1 | k -1 | \$ -2 |
| L -4 | l -4 | ! -2 |
| M -2 | m -2 | . -3 |
| N -3 | n -3 | ; -1 |
| O -3 | o -3 | ' -1 |
| P -2 | p -2 | ' -2 |
| Q -1 | q -1 | ' -1 |
| R -3 | r -3 | ' -3 |
| S -4 | s -4 | |
| T -3 | t -4 | |
| U -2 | u -2 | |
| V -2 | v -2 | |
| W -2 | w -2 | |
| X -1 | x -1 | |
| Y -2 | y -2 | |
| Z -1 | z -1 | |
| & -1 | fi -1 | |
| | fl -1 | |
| | ff -1 | |
| | ffi -1 | |
| | fff -1 | |

REVISED PRICE LIST PER LETTER.

This Price List Supersedes all Others Issued

The prices for all sizes of each style of type shown in this book can be found in this Revised Price List. The left-hand column gives the size of Type or lines Pica. The letters L, M, N, etc., at the top of table, give the class to which the letter belongs, and the figures in the different columns give the price per letter. The sizes of fonts are given above.

Always state whether CAPS alone are wanted, or CAPS and FIGURES, or CAPS, LOWER CASE and FIGURES, or CAPS and LOWER CASE, and how large a font or number of As.





Give full directions for shipping, unless it is desired to leave the matter to us, in which case we will ship the cheapest way, freight or express.

| LINES PICA. | CLASSIFICATIONS. | | | | | | | | | |
|----------------|------------------|-----|-----|------|------|-------|-------|------|------|------|
| | L | M | N | O | P | Q | R | S | T | U |
| 2-line | .06 | .06 | .06 | .06 | .06 | .06 | .08 | .10 | .13 | .16 |
| 3-line | .06 | .06 | .06 | .06 | .06 | .06 | .08 | .12 | .15 | .18 |
| 4-line | .06 | .06 | .06 | .06 | .06 | .06 | .08 | .12 | .15 | .18 |
| 5-line | .06 | .06 | .06 | .06 | .07 | .08 | .09 | .14 | .17 | .20 |
| 6-line | .06 | .06 | .06 | .06 | .08 | .10 | .11 | .16 | .19 | .22 |
| 8-line | .08 | .08 | .08 | .08 | .10 | .12 | .13 | .18 | .22 | .26 |
| 10-line | .09 | .09 | .10 | .10 | .12 | .15 | .16 | .20 | .25 | .30 |
| 12-line | .10 | .10 | .12 | .12 | .14 | .17 | .18 | .23 | .28 | .32 |
| 14-line | .11 | .12 | .13 | .14 | .16 | .20 | .22 | .26 | .30 | .34 |
| 15-line | .12 | .13 | .14 | .15 | .18 | .21 | .24 | .28 | .32 | .36 |
| 16-line | .12 | .14 | .15 | .16 | .19 | .22 | .25 | .30 | .34 | .38 |
| 18-line | .13 | .15 | .17 | .18 | .21 | .24 | .28 | .33 | .37 | .42 |
| 20-line | .14 | .16 | .18 | .20 | .24 | .28 | .32 | .37 | .40 | .44 |
| 24-line | .17 | .19 | .22 | .24 | .28 | .32 | .36 | .42 | .45 | .48 |
| 25-line | .18 | .20 | .23 | .25 | .30 | .34 | .38 | .45 | .48 | .50 |
| 30-line | .21 | .24 | .27 | .30 | .35 | .40 | .44 | .52 | .55 | .58 |
| 36-line | .28 | .31 | .34 | .36 | .41 | .46 | .50 | .56 | .59 | .62 |
| 40-line | .33 | .36 | .38 | .40 | .45 | .50 | .56 | .60 | .63 | .66 |
| 45-line | .36 | .39 | .42 | .45 | .50 | .58 | .63 | .64 | .67 | .70 |
| 50-line | .45 | .47 | .48 | .50 | .56 | .65 | .70 | .70 | .72 | .74 |
| 60-line | .50 | .53 | .56 | .60 | .66 | . . . | . . . | .80 | .83 | .86 |
| 72-line | .60 | .62 | .64 | .72 | .78 | . . . | . . . | .90 | .95 | 1.00 |
| 80-line | .64 | .66 | .68 | .80 | .86 | . . . | . . . | 1.00 | 1.07 | 1.14 |
| 100-line | .75 | .78 | .80 | 1.00 | 1.06 | . . . | . . . | 1.15 | 1.25 | 1.35 |

All styles of Wood Type that are made can be furnished on receipt of sample at above prices, subject to liberal discount.





WOOD RULE.

12 cents per yard on side-wood ; 15 cents per foot on end-wood—in assorted lengths. End-wood Rule cannot be supplied in yard lengths. Solid corners to match all sizes, 25 cents per set of four. Wood Rule is sold at a lesser discount than Wood Type.

| | |
|---|----------|
| STYLE W | 24 POINT |
|  | |
| STYLE U | 18 POINT |
|  | |
| STYLE R | 12 POINT |
|  | |
| STYLE N | 8 POINT |
|  | |
| STYLE H | 18 POINT |
|  | |
| STYLE E | 12 POINT |
|  | |

STAR RULE.

In fonts of 5 feet, with one set of Corners, \$1.90. Star Rule cannot be supplied in yard lengths.

| |
|---|
| No. 27 |
|  |
| No. 23 |
|  |
| No. 24 |
|  |
| No. 20 |
|  |

WOOD POINTERS.

A set contains 25 pieces, matching those in our Metal Pointers.

| | |
|---|--|
|  | |
| 2-line Pointers, per set, \$2.00 | 5-line Pointers, per set, \$3.50 |
| 3 " " " " 2.50 | 6 " " " " 4.00 |
| 4 " " " " 3.00 | 8 " " " " 5.00 |

For other styles of Wood and Star Rules, see our Complete Specimen Book of Wood Type. Sent on application only.

END-WOOD BORDERS.

Kept in stock in 5-foot fonts, with one set of Corners. For a full sheet 10 feet of Border are required.

No. 244 5 FEET WITH CORNERS \$5 40



No. 333 5 FEET WITH CORNERS \$5 40

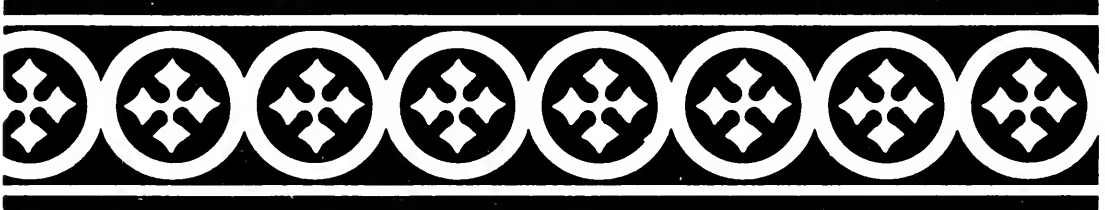

No. 131 5 FEET WITH CORNERS \$4 20



No. 295 5 FEET WITH CORNERS \$4 20



No. 110 5 FEET WITH CORNERS \$4 20



No. 254 5 FEET WITH CORNERS \$3 60



No. 259 5 FEET WITH CORNERS \$3 60



No. 250 5 FEET WITH CORNERS \$3 60



No. 40 5 FEET WITH CORNERS \$3 60



For a complete assortment of Wood Borders, see our Specimen Book of Wood Type. Sent on application only.

CLASS O

No. 653, 10-LINE

10 CENTS PER LETTER

Mat

CLASS O

No. 653, 8-LINE

8 CENTS PER LETTER

Curbs

CLASS O

No. 653, 6-LINE

6 CENTS PER LETTER

Bounds

CLASS O

No. 653, 5-LINE

6 CENTS PER LETTER

Red Sock

For sizes of fonts and prices of other sizes of this series see page 901.
For specimens of other sizes see our Specimen Book of Wood Type, which is
sent only upon application. Lower case and figures made for all sizes.

CLASS O

NO. 642, 10-LINE

10 CENTS PER LETTER

Great

CLASS O

NO. 642, 8-LINE

8 CENTS PER LETTER

Stands

CLASS O

NO. 642, 6-LINE

6 CENTS PER LETTER

Decorate

CLASS O

NO. 642, 5-LINE

6 CENTS PER LETTER

Establish 5

For sizes of fonts and prices of other sizes of this series see page 901. For specimens of other sizes see our Specimen Book of Wood Type, which is sent only upon application. Lower case and figures made for all sizes.

CLASS O

NO. 654, 10-LINE

10 CENTS PER LETTER

Beast

CLASS O

NO. 654, 8-LINE

8 CENTS PER LETTER

Drench

CLASS O

NO. 654, 6-LINE

6 CENTS PER LETTER

Her Grant

CLASS O

NO. 654, 5-LINE

6 CENTS PER LETTER

Sore Hands

For sizes of fonts and prices of other sizes of this series see page 901.
For specimens of other sizes see our Specimen Book of Wood Type, which is
sent only upon application. Lower case and figures made for all sizes.

CLASS P

NO. 641, 10-LINE

12 CENTS PER LETTER

Bands

CLASS P

NO. 641, 8-LINE

10 CENTS PER LETTER

Bradley

CLASS P

NO. 641, 6-LINE

8 CENTS PER LETTER

Founders 5

CLASS P

NO. 641, 5-LINE

7 CENTS PER LETTER

Predominate

For sizes of fonts and prices of other sizes of this series see page 901. For specimens of other sizes see our Specimen Book of Wood Type, which is sent only upon application. Lower case and figures made for all sizes.

CLASS P

NO. 650, 10-LINE

12 CENTS PER LETTER

Ran

CLASS P

NO. 650, 8-LINE

10 CENTS PER LETTER

Coast

CLASS P

NO. 650, 6-LINE

8 CENTS PER LETTER

Disturb

CLASS P

NO. 650, 5-LINE

7 CENTS PER LETTER

Sampson

For sizes of fonts and prices of other sizes of this series see page 901. For specimens of other sizes see our Specimen Book of Wood Type, which is sent only upon application. Lower case and figures made for all sizes.

CLASS O

NO. 644, 10-LINE

10 CENTS PER LETTER

Coat

CLASS O

NO. 644, 8-LINE

8 CENTS PER LETTER

Broth

CLASS O

NO. 644, 6-LINE

6 CENTS PER LETTER

Opera 4

CLASS O

NO. 644, 5-LINE

6 CENTS PER LETTER

Mountain

For sizes of fonts and prices of other sizes of this series see page 901. For specimens of other sizes see our Specimen Book of Wood Type, which is sent only upon application. Lower case and figures made for all sizes.

CLASS O

NO. 627, 10-LINE

10 CENTS PER LETTER

Mad

CLASS O

NO. 627, 8-LINE

8 CENTS PER LETTER

Colts

CLASS O

NO. 627, 7-LINE

8 CENTS PER LETTER

Break

CLASS O

NO. 627, 6-LINE

6 CENTS PER LETTER

Grants

For sizes of fonts and prices of other sizes of this series see page 901. For specimens of other sizes see our Specimen Book of Wood Type, which is sent only upon application. Lower case and figures made for all sizes.

CLASS 0

NO. 189, 10-LINE

10 CENTS PER LETTER

RID

CLASS 0

NO. 189, 8-LINE

8 CENTS PER LETTER

DOG

CLASS 0

NO. 189, 6-LINE

6 CENTS PER LETTER

Bands

CLASS 0

NO. 189, 5-LINE

6 CENTS PER LETTER

Board 6

For sizes of fonts and prices of other sizes of this series see page 901. For specimens of other sizes see our Specimen Book of Wood Type, which is sent only upon application. Lower case and figures made for all sizes.

CLASS O

NO. 629, 10-LINE

10 CENTS PER LETTER

Backs

CLASS O

NO. 629, 8-LINE

8 CENTS PER LETTER

Hunter

CLASS O

NO. 629, 6-LINE

6 CENTS PER LETTER

Exhibited

CLASS O

NO. 629, 5-LINE

6 CENTS PER LETTER

Celebration

For sizes of fonts and prices of other sizes of this series see page 901. For specimens of other sizes see our Specimen Book of Wood Type, which is sent only upon application. Lower case and figures made for all sizes.

CLASS N

NO. 231, 10-LINE

10 CENTS PER LETTER

BISON

CLASS N

NO. 231, 8-LINE

8 CENTS PER LETTER

NORMS

CLASS N

NO. 231, 6-LINE

6 CENTS PER LETTER

Rancher 3

CLASS N

NO. 231, 5-LINE

6 CENTS PER LETTER

Old Banker 5

For sizes of fonts and prices of other sizes of this series see page 901. For specimens of other sizes see our Specimen Book of Wood Type, which is sent only upon application. Lower case and figures made for all sizes.

CLASS N

NO. 647, 15-LINE

14 CENTS PER LETTER

DICE

CLASS N

NO. 647, 10-LINE

10 CENTS PER LETTER

SOBER

CLASS N

NO. 647, 6-LINE

6 CENTS PER LETTER

DRENCHES

For sizes of fonts and prices of other sizes of this series see page 901. For specimens of other sizes see our Specimen Book of Wood Type, which is sent only upon application. Lower case and figures made for all sizes.

CLASS N NO. 646, 10-LINE 10 CENTS PER LETTER

DONE

CLASS N NO. 646, 8-LINE 8 CENTS PER LETTER

MISER

CLASS N NO. 646, 6-LINE 6 CENTS PER LETTER

MOUNDS

CLASS N NO. 646, 5-LINE 6 CENTS PER LETTER

PINE CONE

For sizes of fonts and prices of other sizes of this series see page 901. For specimens of other sizes see our Specimen Book of Wood Type, which is sent only upon application. Lower case and figures made for all sizes.

CLASS O

NO. 21, 10-LINE

10 CENTS PER LETTER

DOG

CLASS O

NO. 21, 8-LINE

8 CENTS PER LETTER

RIMS

CLASS O

NO. 21, 6-LINE

6 CENTS PER LETTER

HOUSE

CLASS O

NO. 21, 5-LINE

6 CENTS PER LETTER

SPOKEN

For sizes of fonts and prices of other sizes of this series see page 901. For specimens of other sizes see our Specimen Book of Wood Type, which is sent only upon application. Lower case and figures made for all sizes.

CLASS M

NO. 45 10-LINE

9 CENTS PER LETTER

RIDES

CLASS M

NO. 45, 8-LINE

8 CENTS PER LETTER

SHINER

CLASS M

NO. 45, 6-LINE

6 CENTS PER LETTER

GROUNDS

CLASS M

NO. 45, 5-LINE

6 CENTS PER LETTER

Numerate 5

For sizes of fonts and prices of other sizes of this series see page 901. For specimens of other sizes see our Specimen Book of Wood Type, which is sent only upon application. Lower case and figures made for all sizes.

CLASS L

NO. 81, 15-LINE

12 CENTS PER LETTER

SPRUCE

CLASS L

NO. 81, 10-LINE

9 CENTS PER LETTER

TIME RUNS

CLASS L

NO. 81, 6-LINE

6 CENTS PER LETTER

BRADENBURGH 8

For sizes of fonts and prices of other sizes of this series see page 901. For specimens of other sizes see our Specimen Book of Wood Type, which is sent only upon application. Lower case and figures made for all sizes.

CLASS L

NO. 50, 10-LINE

9 CENTS PER LETTER

HOMER

CLASS L

NO. 50, 8-LINE

8 CENTS PER LETTER

GRINDER

CLASS L

NO. 50, 6-LINE

6 CENTS PER LETTER

NUMBERED

CLASS L

NO. 50, 5-LINE

6 CENTS PER LETTER

Government 4

For sizes of fonts and prices of other sizes of this series see page 901. For specimens of other sizes see our Specimen Book of Wood Type, which is sent only upon application. Lower case and figures made for all sizes.

CLASS O

NO. 23, 10-LINE

10 CENTS PER LETTER

DOOB

CLASS O

NO. 23, 8-LINE

8 CENTS PER LETTER

SUMM

CLASS O

NO. 23, 6-LINE

6 CENTS PER LETTER

CORES

CLASS O

NO. 23, 5-LINE

6 CENTS PER LETTER

MORNS

For sizes of fonts and prices of other sizes of this series see page 901.
For specimens of other sizes see our Specimen Book of Wood Type, which is
sent only upon application. Lower case and figures made for all sizes.

CLASS N

NO. 37, 10-LINE

10 CENTS PER LETTER

HIDES

CLASS N

NO. 37, 8-LINE

8 CENTS PER LETTER

DESIGN

CLASS N

NO. 37, 6-LINE

6 CENTS PER LETTER

MOTHERS

CLASS N

NO. 37, 5-LINE

6 CENTS PER LETTER

Side Boards

For sizes of fonts and prices of other sizes of this series see page 901. For specimens of other sizes see our Specimen Book of Wood Type, which is sent only upon application. Lower case and figures made for all sizes.

CLASS N

NO. 24, 15-LINE

14 CENTS PER LETTER

ROBINS

CLASS N

NO. 24, 10-LINE

10 CENTS PER LETTER

POINTERS

CLASS N

NO. 24, 6-LINE

6 CENTS PER LETTER

NATIONAL SONGS

For sizes of fonts and prices of other sizes of this series see page 901. For specimens of other sizes see our Specimen Book of Wood Type, which is sent only upon application. Lower case and figures made for all sizes.

CLASS N

NO. 95, 10-LINE

10 CENTS PER LETTER

ROUND HEADS

CLASS N

NO. 95, 8-LINE

8 CENTS PER LETTER

BOUNDING HORSE

CLASS N

NO. 95, 6-LINE

6 CENTS PER LETTER

DUTCHMAN BREECHES

CLASS N

NO. 95, 5-LINE

6 CENTS PER LETTER

Womens Beautiful Costumes

For sizes of fonts and prices of other sizes of this series see page 901. For specimens of other sizes see our Specimen Book of Wood Type, which is sent only upon application. Lower case and figures made for all sizes.

CAMPAIGNER SERIES

Order by No. and give size.

| | |
|----------------------|----------------------|
| 12 LINE, \$0 75 EACH | 24 LINE, \$1 50 EACH |
| 15 LINE, 0 85 EACH | 30 LINE, 1 75 EACH |
| 18 LINE, 1 00 EACH | 36 LINE, 2 00 EACH |
| 20 LINE, 1 25 EACH | 40 LINE, 2 25 EACH |

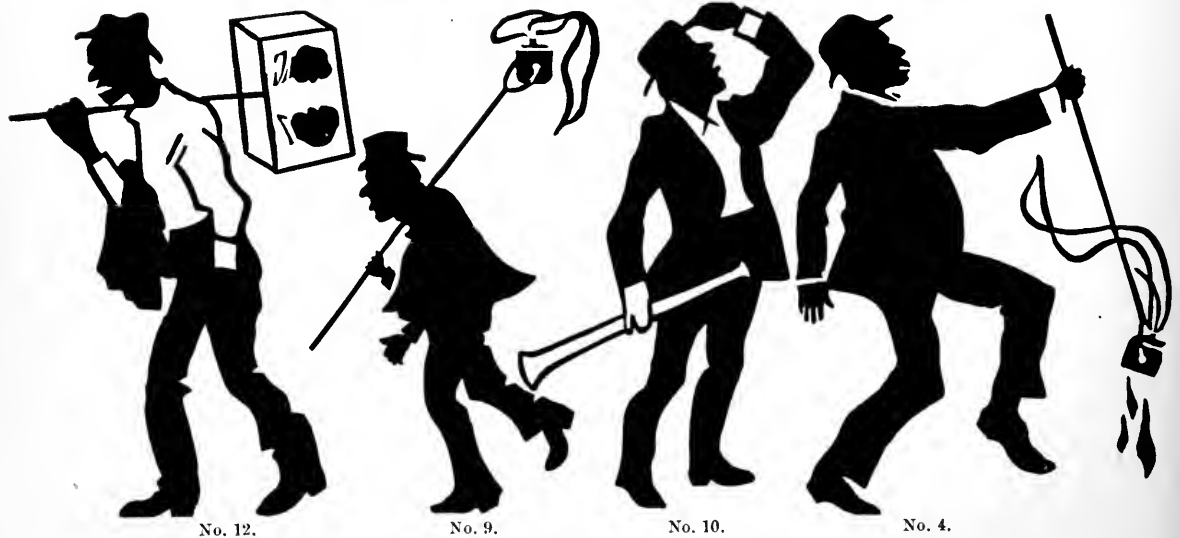

For smaller Campaigners, see page 812

Illustrated Catalogue and Price List of Printing Machinery and Supplies, Wood Goods and Inks

Part XX.



**EVERYTHING
FOR THE
PRINTER**

~ ~ American ~ ~
Type Founders Company

BRANCHES COVERING THE CONTINENT

1900

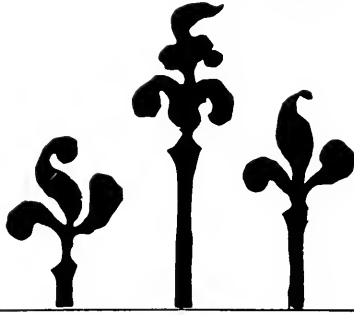

NOTICE TO BUYERS

The American Type Founders' Company offers only the best lines of Printing Material and Machinery, covering all the requirements of the printing office.

As the largest buyer in the world of this class of goods, it commands the best in the market at the lowest prices, and is in the best possible position to satisfy its customers.

Buyers of large or small outfits will always receive the best money's worth. Detailed estimates will be furnished, on application to the nearest Branch, upon receipt of information concerning the amount to be invested, terms required, and work to be done with such outfits.

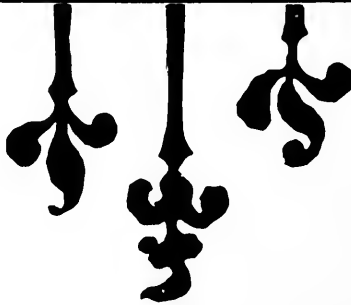

PRINTERS' WOOD GOODS.

WOODEN MALLETS.

Made of thoroughly seasoned and selected stock; handles screwed in; finished in oil; attractive shape. The lignumvitæ mallets can be specially recommended. They are heavier than hickory mallets, and wear like iron.

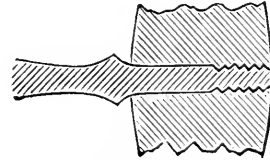
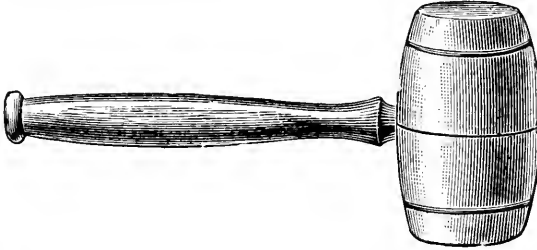

Shows Handle
screwed in.

| | | | |
|---|--------|------------------------------------|-------------|
| Hickory, small, 2½×4½ inches . . . | \$0 25 | Lignumvitæ, 2¼×3½ inches | \$0 50 |
| Hickory, medium, 3×5 inches | 0 30 | Lignumvitæ, 3×5 inches | 0 60 |
| Hickory, large, 3½×6 inches | 0 40 | Lignumvitæ, 3½×5½ inches | 0 75 |
| IRON BOUND WOODEN Mallet | | | 1 00 |

PATENT RAWHIDE MALLETS.

This mallet is made entirely of rolled rawhide, except handle, which is of wood.

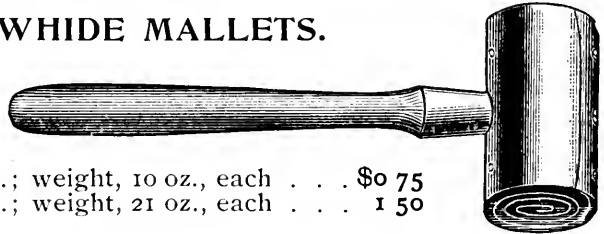

| | |
|---|--------|
| No. 4. Diameter, 2 in.; length, 3¼ in.; weight, 10 oz., each . . . | \$0 75 |
| No. 5. Diameter, 2½ in.; length, 4¼ in.; weight, 21 oz., each . . . | 1 50 |

RAWHIDE BOUND MALLETS.

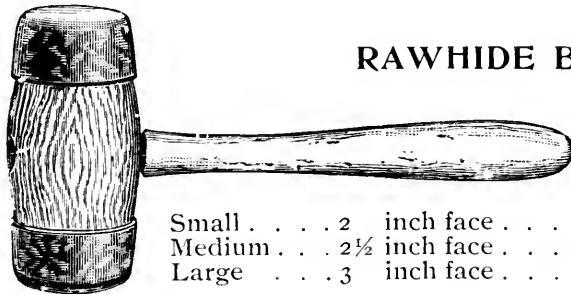

The most durable, finest finished, and hand-somest made. Positively will not split. The spring of the hide-facing cushions the blow and prevents jarring the muscles.

| | |
|---|--------|
| Small 2 inch face | \$0 60 |
| Medium 2½ inch face | 0 75 |
| Large 3 inch face | 1 00 |

PLANERS.

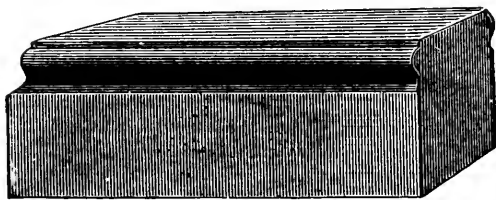

| | |
|---|--------|
| Maple, small, 3×6 inches | \$0 25 |
| Maple, large, 3½×8 inches | 0 30 |
| Maple, leather top, 3½×8 inches | 0 40 |

PROOF PLANERS.

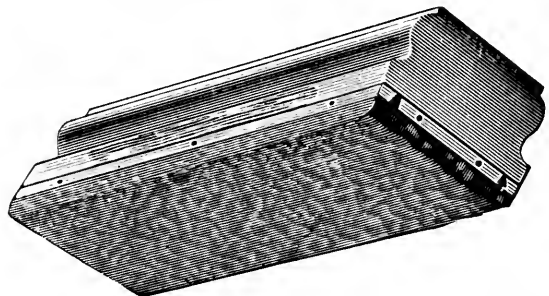

| | |
|-------------------------------------|--------|
| 3½×8 inches | \$0 60 |
| Piece Felt for recovering | 0 30 |

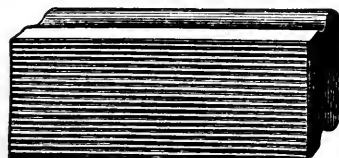

LINOTYPE PLANER.

The Linotype planer has a corrugated rubber face and is used for removing the burr from Linotype slugs.

| | |
|-----------------------|--------|
| Price, each | \$0 50 |
|-----------------------|--------|

PRICE LIST OF CASES.

For illustrations of Cases, see pages 936 and 937.

**PATENT
NEW DEPARTURE
TYPE CASES.**

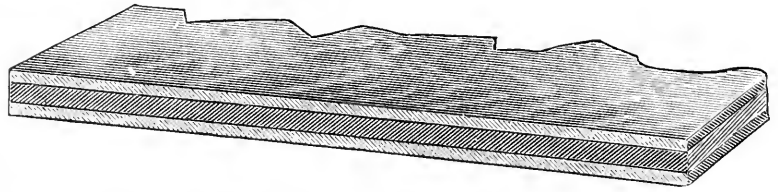

Shows three-ply case bottom, which will not warp nor crack.

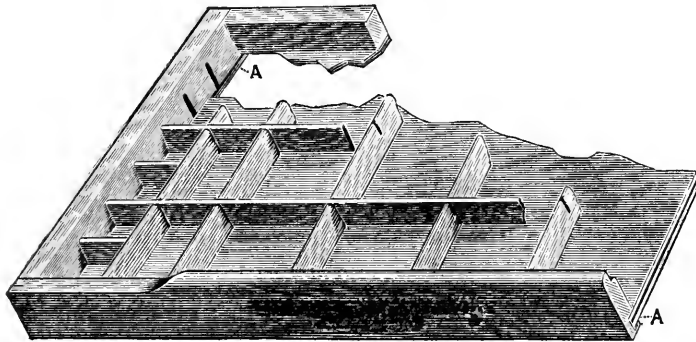

Shows at AA how the three-ply bottoms are set into the front and side rails, so that the case slides on the rails instead of on the case bottoms.

Our cases all have patent "New-Departure" three-ply bottoms, which prevent splitting, warping and shrinking. These bottoms are set into the side and front rails (see AA), so that the case slides on the side rails. As the grain of the side rails and of the case-runs in stands and cabinets run the same way, the cases slide much easier and with considerable less wear and tear.

FULL-SIZE CASES.

Size, 32¼ × 16⅝ inches.

| | Clasp Cases. | Ordinary Cases. |
|--|-----------------|--------------------|
| News Cases, per pair | \$1 75 | \$1 60 |
| Cap Case | 0 88 | 0 80 |
| German News Cases, per pair | 1 75 | 1 60 |
| Italic or Job Case | 1 00 | 0 90 |
| California Job Case (see cut page 936) | 1 00 | 0 90 |
| Yankee Job Case—32 cap boxes—(see cut page 937) | | 1 00 |
| Improved Job Case (see cut page 936) | | 1 20 |
| Paterson Job Case (see cut page 936) | | 1 00 |
| New York Job Case (see cut page 936) | | 1 00 |
| Well's Two-font Job Case (see cut page 938) | | 0 90 |
| Triple Case | 1 00 | 0 90 |
| Greek Cases (upper and lower), per pair | 3 75 | 3 50 |
| Music Cases (upper, lower and side), each | 1 00 | 0 90 |
| Double Lower Case (see cut page 936) | | 1 20 |
| Rule Case | | 1 15 |
| Space and Quad Case (see cut page 937) | | 1 00 |
| Lead and Slug Case | | 1 00 |
| Border Case | | 1 25 |
| Figure Case | | 1 00 |
| Metal Furniture Case (double depth), takes three layers of Furniture (see cut page 937) | | 2 00 |
| Metal Furniture Case (single depth), takes two layers of Furniture (see cut page 937) | | 1 50 |
| Blank Case | | 0 65 |
| Wood Type No. 1 or Script Case, with bars (see page 937) | | 0 90 |

See also Special Wood-Type Cases listed on next page.

THREE-QUARTER CASES.

Size, 26¼ × 16⅝ inches.

| | | |
|---|-----------|--------|
| News Cases, per pair | \$1 65 | \$1 50 |
| Cap Case | 0 85 | 0 75 |
| Italic or Job Case | 0 95 | 0 85 |
| California Job Case (see cut page 936) | 0 95 | 0 85 |
| Yankee Job Case—32 cap boxes—(see cut page 937) | | 0 85 |
| Triple Case | | 0 85 |
| Blank Case | | 0 60 |

TWO-THIRD CASES.

CAUTION.—There are two widths of two-third cases in use. If cases are required to fit stands already in use it is necessary, when ordering, to state exact width required, otherwise we will send our standard width, which is $21\frac{3}{4} \times 16\frac{5}{8}$ inches.

| | Ordinary Cases. |
|---|-----------------|
| New Cases, per pair | \$1 40 |
| Job Case (thirty-two cap boxes) | 0 75 |
| Yankee Job Case (twenty-eight cap boxes) | 0 75 |
| California Job Case | 0 75 |
| Rule Case | 0 90 |
| Lead and Slug Case | 0 75 |
| Brass Leader Case | 0 75 |
| Script Case | 0 75 |
| Improved Job Case ($19\frac{3}{4}$ inches). Is deeper than the regular case, and has additional boxes for small caps | 0 90 |
| Border Case | 0 90 |
| Blank Case | 0 45 |

ROOKER CASES.

A popular size for newspaper offices. Furnished to order only. Size, $28\frac{1}{2} \times 14$ inches over all.

| | Patent Clasps. |
|--------------------------------|----------------|
| News Cases, per pair | \$1 75 |
| Italic or Job Case | 1 00 |
| California Job Case | 1 00 |

SPECIAL CASES.

| | Ordinary Cases. |
|---|-----------------|
| Wood-Type Case No. 1 ($16\frac{5}{8} \times 32\frac{1}{4}$ inches) | \$0 90 |
| Wood-Type Case No. 2 ($23 \times 32\frac{1}{4}$ inches) | 1 00 |
| Mammoth Wood-Type Case No. 3 (23×44 inches) | 1 30 |
| Wisconsin Combination "Quarter" Cases, Nos. A, B, C, D, for holding piece fractions, signs, fractions, figures and borders (see cut page 935), each | 0 65 |

RULE CASES.

| | |
|--|--------|
| Regular Rule Case, full-size | \$1 15 |
| Regular Rule Case, two-third size (see note at top of page) | 0 90 |
| Compact Rule Case. Four of them fit in a full-size blank case (see page 934), each | 0 90 |
| Sanspareil Rule Case | 2 00 |
| * Harris Rule Case, No. 1, holds two 8-pound fonts | 1 25 |
| * Harris Rule Case, No. 2, holds one 16-pound font | 1 00 |
| * Harris Rule Case, No. 3, } used together, hold one 32-pound font | 0 75 |
| * Harris Rule Case, No. 4, } | 1 00 |
| Full-size Blank Case, to hold four Harris Rule Cases | 0 65 |

* See cut and description, page 934.

PATENT CLASP CASES.

These cases are of unusual strength, owing to the use of a brass clasp over the corner of each box and a long pin which is driven through center of each clasp and clinched, holding the partitions firmly to the bottom of the case. This feature, in combination with our "New-Departure"-case bottoms, makes these cases the strongest and most durable, especially for body type and in newspaper offices.

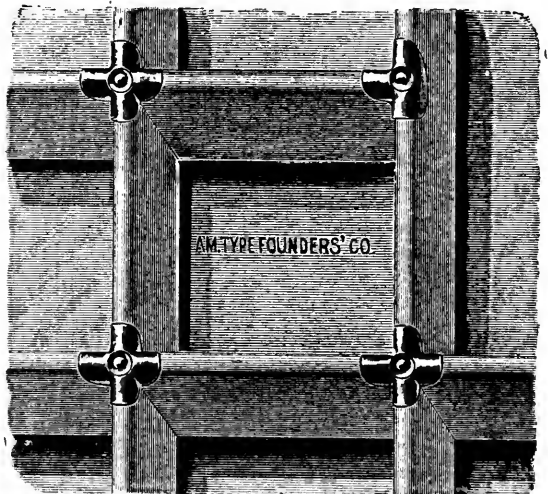

Section of Patent Clasp Case.

HARRIS RULE CASES.

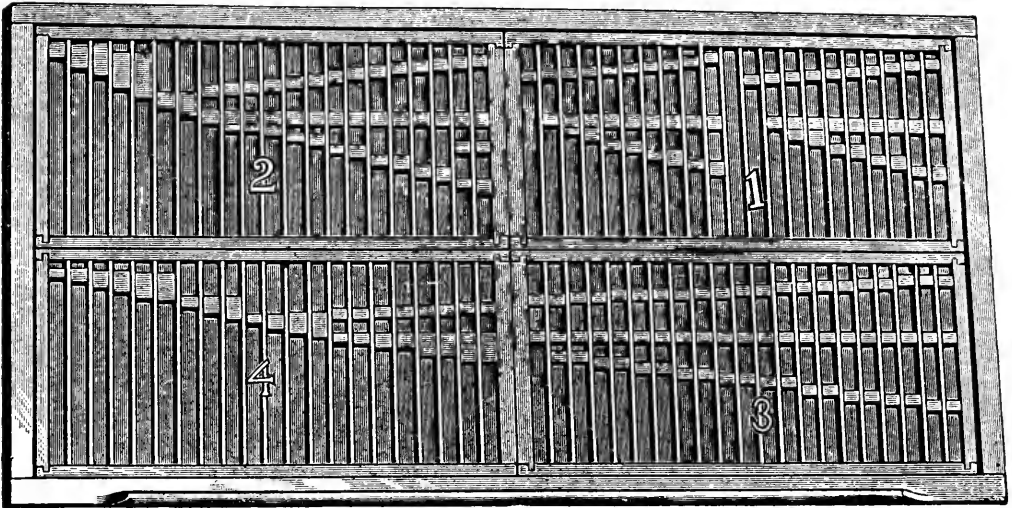

Four Harris Rule Cases in a Full-size Blank Case. Price, \$4 65.

In HARRIS RULE CASES the rule cannot fall flat—must always stay on end. Pi is prevented, because each box is accurately adjusted for its special size—for instance, a 21-em rule will not go into the 20-em rule box. Generous provision is made for the smaller sizes—the most valuable sizes in a labor-saving font. The cases may be used in sets or separately, as Nos. 1 and 2 are complete in themselves. Four of them fit into a full-size blank case.

The rule referred to below is 2-point, which is the most used.

No. 1 Harris Rule Case holds two complete small fonts of Labor Saving Rule, each weighing 8 pounds, or 16 pounds in all. Each half of this case holds eighteen pieces each length from 1 to 8½ ems (varying by ens), and eighteen pieces each from 9 to 18 ems (varying by ems) and nine pieces each 19, 20, 21, 22, 24, 26 and 28 ems, besides boxes for right and left miters.

No. 2 Harris Rule Case holds one complete font of 16 pounds weight or less. It has compartments for thirty-six pieces each from 1 to 9 ems long (varying by ens), eighteen pieces each from 10 to 24 ems long (varying by ems), and eighteen pieces each of 26, 28, 30, 32, 34, 36 ems long, besides boxes for right and left miters. A large proportion of small lengths allowed for.

Nos. 3 and 4 Harris Rule Cases are designed to be used together to hold a font of rule suitable for a large office, weighing 32 pounds or less. Two and in some cases four boxes are used to hold the most-used sizes. Each case has its proportion of the small sizes, so that if it is desired to carry one case to a compositor's stand for use in rule work, the other is available in its regular place with a good working font. These cases have compartments for seventy-two pieces each from 1 to 9 ems long (varying by ens), thirty-six pieces each from 10 to 24 ems long (varying by ems), and eighteen pieces each from 25 to 36 ems long (varying by ems), and boxes for right and left miters.

| | |
|---|--------|
| Harris Rule Case No. 1, holds two 8-pound fonts | \$1 25 |
| Harris Rule Case No. 2, holds one 16-pound font | 1 00 |
| Harris Rule Case No. 3, } used together, hold one 32-pound font { | 0 75 |
| Harris Rule Case No. 4, } | 1 00 |
| Full-size Blank Case, to hold four of above | 0 65 |

COMPACT RULE CASE.

Has compartments for brass rule from 1 to 36 ems Pica, and from 1½ to 9½ ems Pica, with places for miters. Size outside, 7¾ × 15¼ inches. Four fit in a full-size blank case. For Full-size Rule Cases see page 933.

Price \$0 90

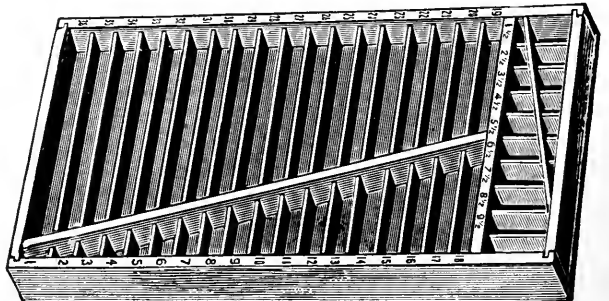

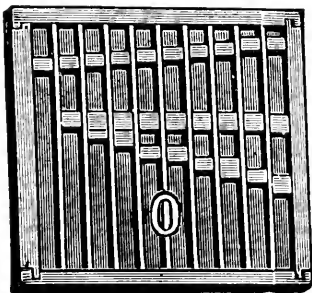

INDIVIDUAL LEAD OR RULE CASE.

In this a compositor may keep his much valued 12-to-Pica and other thicknesses of leads for justifying purposes, his pickups of dashes, rule, etc. The case can be kept in his drawer or on his galley rest. It has boxes from 1 to 9½ ems (varying by ems), from 10 to 22 ems (varying by ems), and from 22 to 28 ems (varying by two ems), with a long box for longer lengths. It is also useful for holding a small font of labor-saving brass rule.

Each, 7×7½ inches over all \$0 75

LEADER BOX.

The handiest receptacle for leaders. Can be put on a cap case, on a stone, or on a galley rest, bringing leaders close to hand. One or more required in every office for every size of body type used.

Each, 5×8×1¼ inches over all . . . \$0 25
Per dozen 2 50

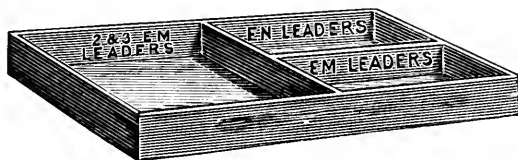

See May's Patented Leader Box shown on page 1075.

WISCONSIN COMBINATION "QUARTER" CASES.

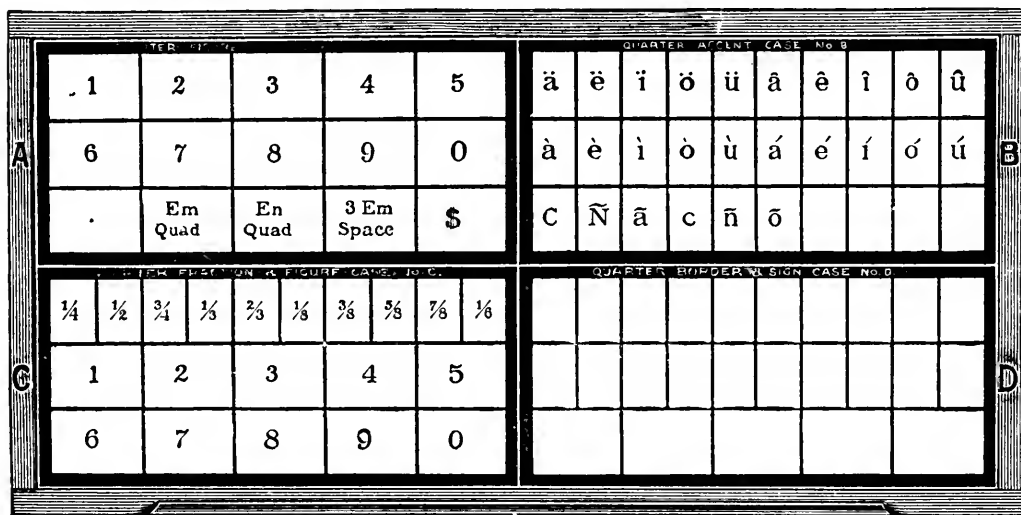

Shows four "Quarter" Cases in Full-size Blank Case.

Signs, borders, accents, split fractions, although most expensive, are usually stowed away in odd boxes of cap cases, and are rarely to be found when needed. "Quarter" Cases supply a means of keeping these valuable sorts where they can be found. They can be placed on a cap case, on a stand, or on the stone, convenient to hand of compositor. In setting mathematical work, foreign languages, dictionaries, and special catalogues, these "Quarter" Cases will prove invaluable. We show a few schemes for laying signs, fractions, etc., but various other uses for special purposes will suggest themselves to the "intelligent compositor."

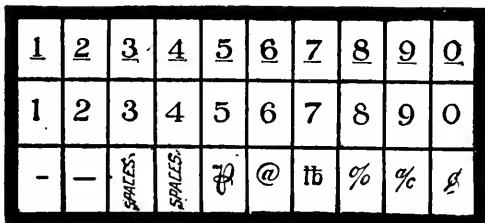

For Split Fractions and Commercial Signs.

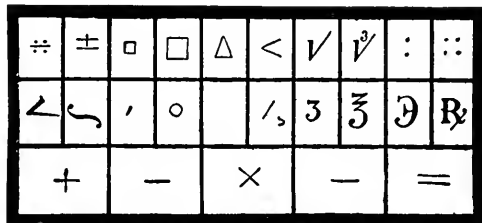

For Algebraic and Medical Signs.

Quarter Case No. A, for Figures, etc. \$0 65
 Quarter Case No. B, for Accents, Split Fractions, etc. 0 65
 Quarter Case No. C, for Figures, Fractions, etc. 0 65
 Quarter Case No. D, for Signs, Borders, etc. 0 65
 Per set of four, in regular Full-size Blank Case 3 00

ILLUSTRATIONS OF CASES.

It is unnecessary to illustrate the most-used styles of cases. Nearly all the cases illustrated here have exceptional merit.

CALIFORNIA JOB CASE.

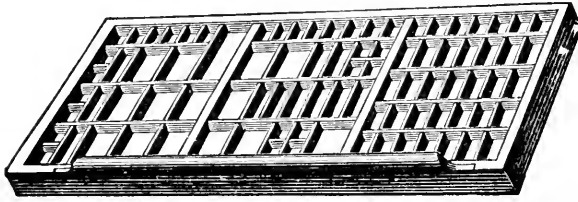

See "lay-out" on page 938

Has fourteen boxes less on cap side than the regular italic job case, thus giving more space for the cap alphabet. A more satisfactory case for the ordinary job font than the italic job case, especially in three-quarter size.

Full-size \$0 90
 Three-quarter 0 85

IMPROVED JOB CASE.

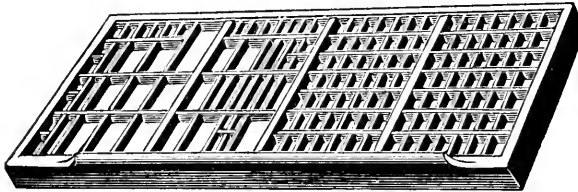

Holds caps, small caps, lower case and figures, or a cap and lower-case font (with figures) and an extra cap font. Will also hold three cap fonts, all with figures. Made full-size only.

Price \$1 20

NEW YORK JOB CASE.

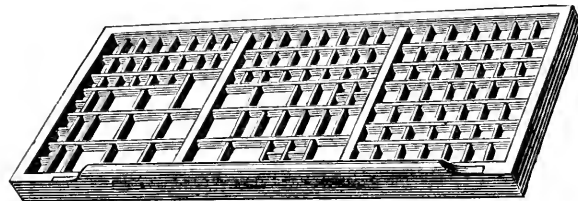

Holds caps, small caps, lower case and figures. The small caps are placed on the same side as the lower-case boxes, and above them. The lower-case boxes are therefore smaller than in a California job case. Made full-size only.

Price \$1 00

PATERSON JOB CASE.

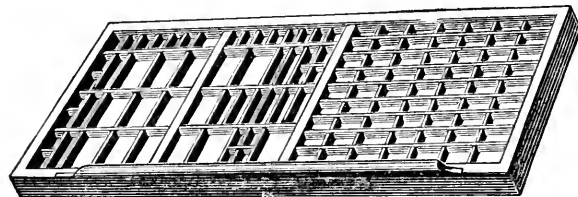

Holds caps, small caps, lower case and figures. The small caps are placed above the cap boxes, all of which are widened, thereby reducing the sizes of the lower-case boxes. A very useful case. Made full-size only.

Price \$1 00

DOUBLE LOWER CASE.

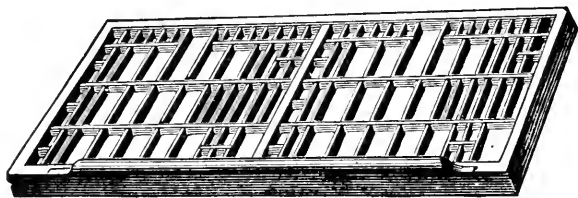

A most useful case. In most job fonts the caps occupy as much space as the lower case, while ordinary job cases give the caps one-half the room allotted the lower-case. In this case the space is divided equally between the caps and lower case. Made full-size only.

Price \$1 20

ROOKER CAP CASE.

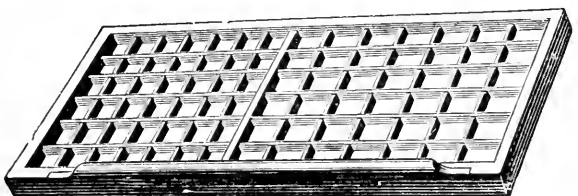

Made only in Rooker size (28¼ x 14¼). Gives more space for caps and less for small caps than the regular cap case. Rooker cases are two inches narrower than ordinary cases, and cannot be used on the same stands.

Price \$0 88

ILLUSTRATIONS OF CASES.

YANKEE JOB CASE.

In two-third size, a case with cap boxes at the back is a necessity, but in full-size and three-quarter size this case is inferior in utility to other job cases.

- Full-size (32 cap boxes) \$1 00
- Three-quarter (32 cap boxes) 0 85
- Two-third (28 cap boxes) 0 75

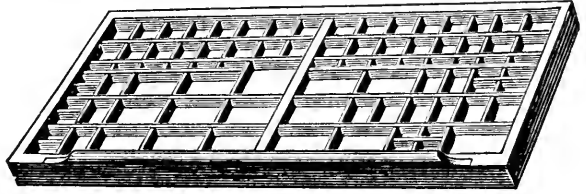

SPACE AND QUAD CASE.

This is an absolutely essential case in offices where economy of time and material is a consideration. Each case holds eight sizes of spaces and quads. Made full-size only.

- Price \$1 00

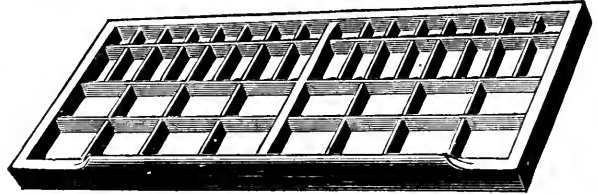

METAL FURNITURE CASE.

A handy receptacle for metal furniture. There are compartments for 1, 2, 3, 4, 5, 6, 8, 10, 15, 20, 25 and 50 ems. The double-depth case takes three layers of furniture; the single-depth case takes two layers. The latter can be put in a full-size case stand or rack, and the double-depth case is for use on top of a stand or cabinet, or a special place can be made for it under the stone. Made full-size only.

- Double-depth \$2 00
- Single-depth 1 50

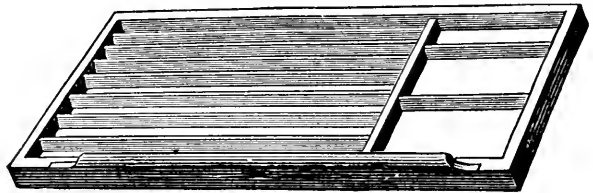

SCRIPT OR WOOD-TYPE CASE.

Although mostly sold for wood type, these cases are made so accurately as to be suitable for large script fonts. The movable partitions are adjustable by Picas. Nothing injures expensive script type so much as tumbling about in a case. The use of script cases will save type. Made in full- and two-third sizes.

- Full-size \$0 90
- Two-third size 0 75

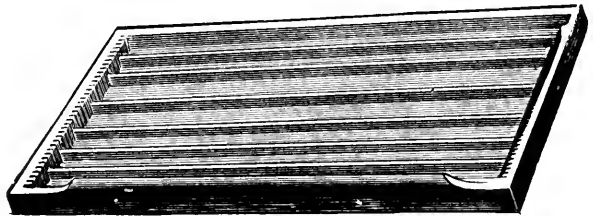

MAMMOTH WOOD-TYPE CASE.

No. 3 (Mammoth) Wood-Type Case, 23x44 inches, with slotted sides. For special rack to hold this size case, see page 941. There are two more sizes of wood-type cases made. For prices see page 933.

- Price of No. 3 Wood-Type Case \$1 30

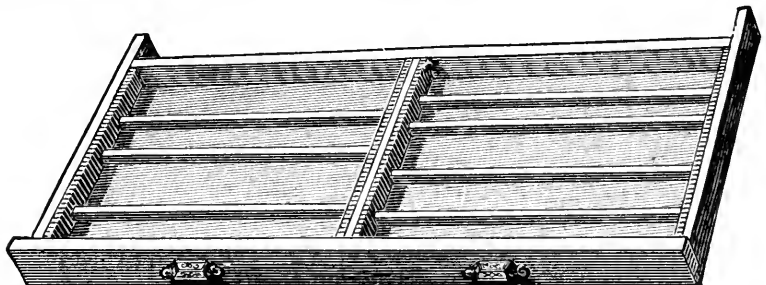

WELLS' TWO-FONT JOB CASE.

A new improved job case with extra large cap boxes, designed to hold two fonts of caps and figures. The boxes in this case are so arranged in size that there is no waste room. In dividing this case to hold fonts of capitals, figures and points, the aim has been to get as large boxes as possible for the letters, while the figures, points and odd characters have been disposed of in boxes no larger than their importance demands. By this means the greatest economy of space has been obtained.

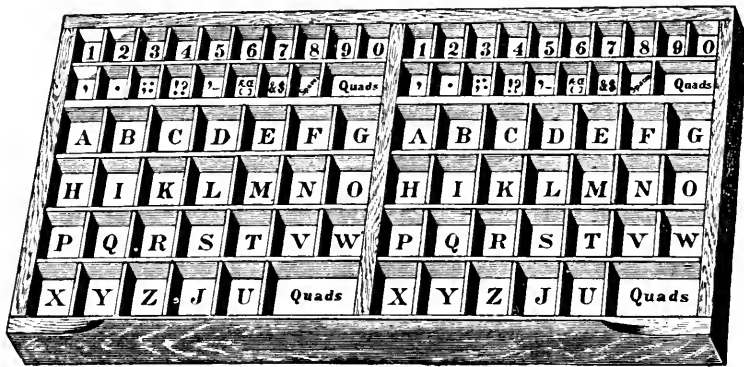

The Well's Two-font Job Case, with extra large Cap Boxes.

The cap boxes in this case have each an area of 5¼ square inches, which is about one-third greater than that of a box in a regular news cap case. No change has been made in the "lay" of the case. The boxes are all in their regular positions, the same as in an ordinary cap or job case.

The figure boxes are all in the back row, it being the most convenient, as it is evident that when figures are not needed they are farthest removed. When these cases are used in a cabinet, this feature will be appreciated. One side of the case can be used for lower-case, if desired. Made in the "New Departure" style, with three-ply bottom, like all other cases manufactured by us.

This case can be substituted in any of our cabinets, in whole or in part, without extra charge. Price, 90 cents.

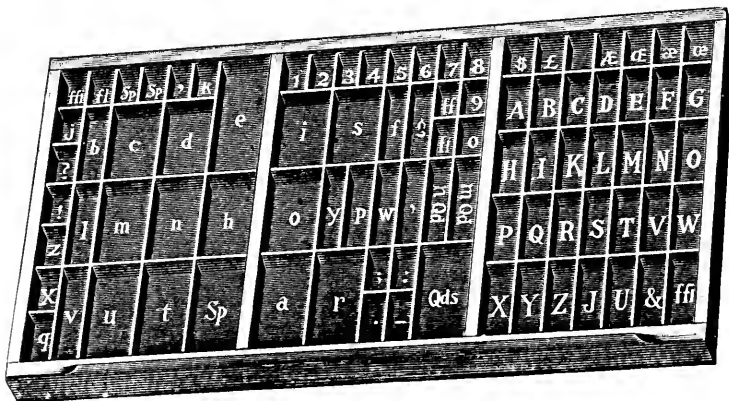

"Lay-out" for California Job Case shown on page 936

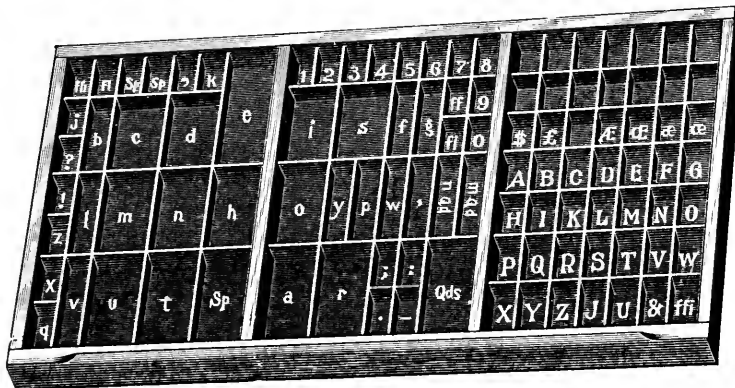

"Lay-out" for regular Job or Italic Case.

ROLL FRONT CASE RACKS

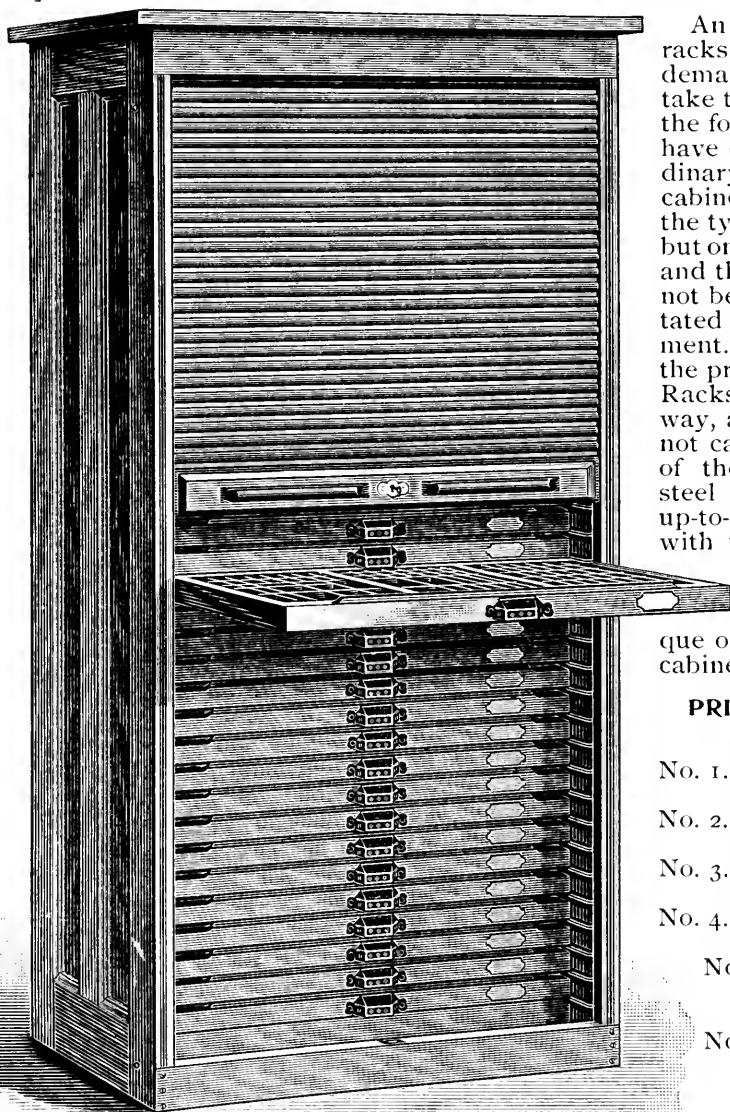

An entirely new feature in case racks. There has been a constant demand for a case rack that would take the old cases and utilize them in the form of a cabinet. Many printers have desired to do away with the ordinary case racks and substitute a cabinet, and thus increase the life of the type by keeping it free from dust; but on account of the expense involved and the fact that their old cases could not be sold or utilized, they have hesitated in making the needed improvement. This new case rack solves the problem. These Roll Front Case Racks are equal to cabinets in every way, and they really are cabinets and not case racks in the ordinary sense of the term. They are fitted with steel runs, and they are thoroughly up-to-date. The roll front is fitted with the finest brass desk lock. A single lock secures the entire tier of cases. These racks are made of ash, finished in antique oak, same as regular high-grade cabinets.

PRICES QUOTED ARE FOR CASE RACKS ONLY.

- | | |
|---|---------|
| No. 1. With racks for 16 cases; height, 45 inches | \$20 00 |
| No. 2. With racks for 20 cases; height, 53 inches | 23 00 |
| No. 3. With racks for 25 cases; height, 63 inches | 28 00 |
| No. 4. With racks for 30 cases; height, 73 inches | 32 00 |
| No. 5. With racks for 35 cases; height, 83 in- ches | 35 00 |
| No. 6. With racks for 40 cases; height, 93 in- ches | 40 00 |
- Case pulls, 3 cts. each.

AUTOCRAT CASE STAND.

This is a printer's stand or frame in its simplest, most compact and convenient form. The most prominent feature is a galley tray, under each lower case, where compositors can empty their sticks by simply pushing the lower case up sufficiently to expose the galley, after which the case is drawn back to its place.

Each single stand accommodates two pairs of news cases, fifteen full-size job cases, and six news galleys. The double stand is made so backs of job cases come together, and will accommodate two pairs of news cases, thirty full-size job or triple cases and six galleys. A large space on top, back of the brackets, may be used for storing live or dead tied-up matter.

- | | | |
|--|-----|---------|
| Single stand for 19 cases | net | \$ 8 50 |
| Single stand for 19 cases, with paneled ends and back | net | 10 00 |
| Double stand for 34 cases | net | 10 00 |
| Double stand for 34 cases, with paneled ends | net | 11 00 |

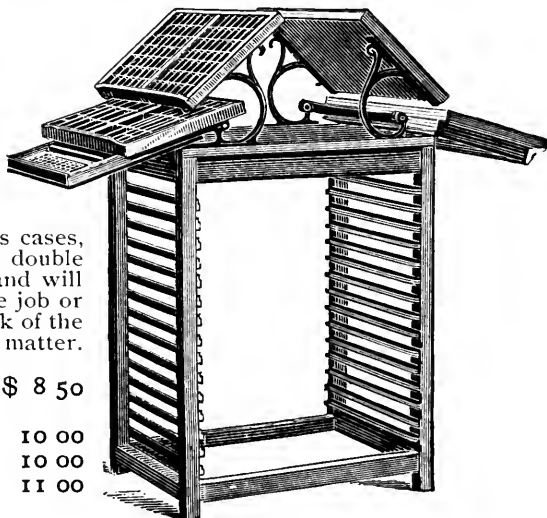

CASE STANDS.

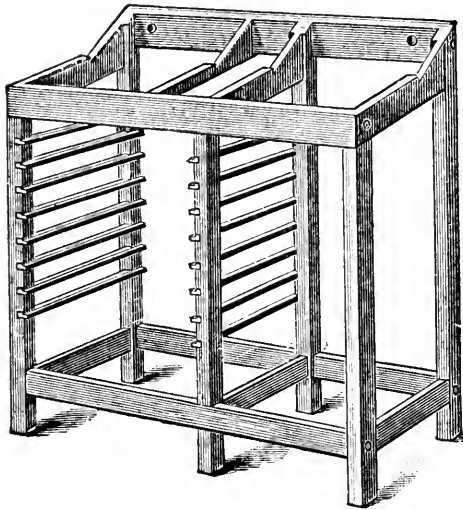

No. 6. Double News Stand, with Eight Racks.

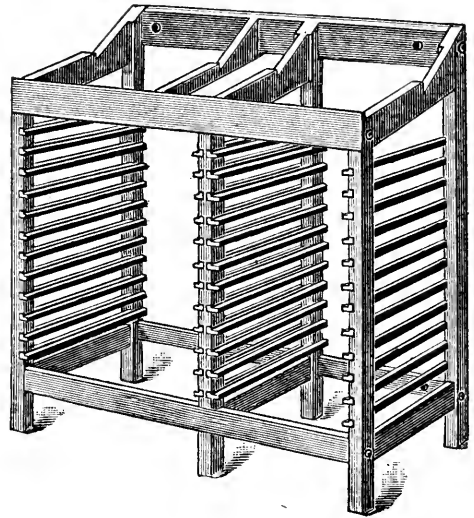

No. 11. Double Job Stand, with Racks for Twelve Full-size and Twelve Two-third Cases.

PRICE LIST OF CASE STANDS.

| | | |
|----------|---|--------|
| No. 1. | Single, without racks | \$2 75 |
| No. 2.* | Single, with racks for 12 two-third cases | 3 00 |
| No. 2½ | Single, with racks for 12 three-quarter cases | 3 00 |
| No. 4. | Single, with racks for 12 full-size cases | 3 25 |
| No. 6. | Double News, with racks for 8 full-size cases (see illustration) | 3 75 |
| No. 8. | Double News, with racks for 12 full-size cases | 4 75 |
| No. 11.* | Double Job Stand, with racks for 12 full-size and 12 two-third cases (see illustration) | 5 50 |
| No. 12. | Double Job Stand, with racks for 12 full-size and 12 three-quarter cases | 5 75 |
| No. 15. | Double Stand, with Galley Rest, and racks for 24 full-size cases (see illustration) | 6 00 |
| No. 17. | Double City Stand, with racks for 30 full-size cases (see illustration) | 8 00 |

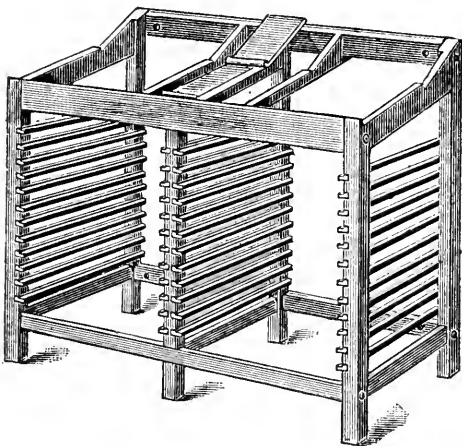

No. 15. Double Stand, with Galley Rest, and Racks for Twenty-four Full-size Cases.

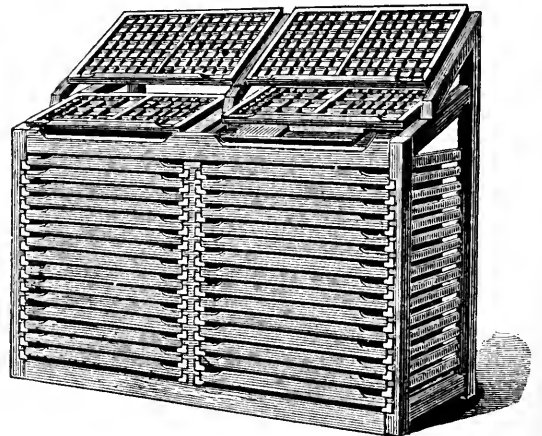

No. 17. Double City Stand. The upper cases project over the lower, bringing the caps nearer the hand. There is a shelf to hold a galley under the lower case, which can be pushed back to permit matter to be emptied on the galley.

**CAUTION.—There are two widths of two-third cases in use. In ordering it is necessary to state exact width of two-third case the stand is required to hold, otherwise we will send stands to take in our standard width of two-third cases.*

NEW YORK SPACE-SAVING CASE STANDS.

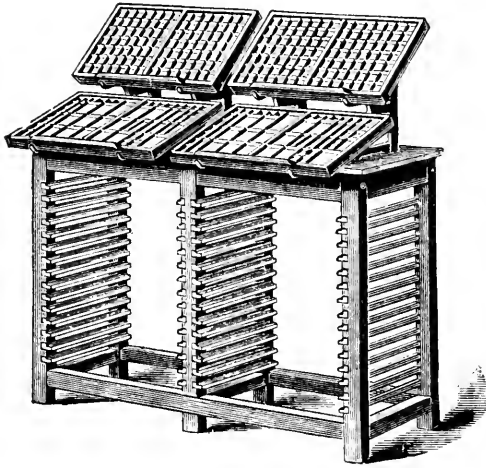

New York Double Stand.

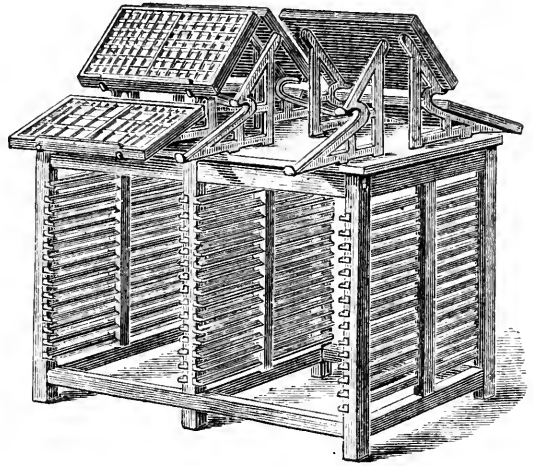

New York Quadruple Stand (see end view below).

These are *space-saving, rent-reducing stands*. Two New York Double Stands, holding sixty cases in racks and four pairs cases on top, occupy eighteen square feet of floor space, as against thirty square feet occupied by two ordinary double stands, holding at most forty-eight cases in racks and four pairs cases on top—a saving of twelve square feet. Two Double City Stands occupy a floor space of twenty-five square feet as against seventeen feet occupied by one Quadruple New York Stand—a saving of eight square feet. This saving is obtained by making the racks correspond to size of cases exactly, bringing forward the cap cases so that they do not overhang at the back of stand (as they do on ordinary stands), and extending the lower cases several inches into the alley.

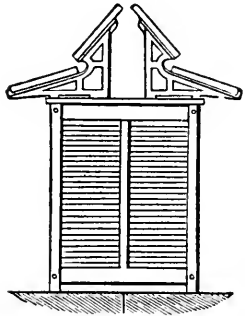

End view of New York Window and Quadruple Stands.

OTHER POINTS OF SUPERIORITY.

The lower cases project into the alley several inches, affording the compositor ample leg room, and allowing him to get closer to the type. The angle of the lower case is just right for rapid setting. The upper case is raised above the lower, and brought forward closer to the compositor's hand, while not obstructing the figure boxes of the lower case. The cases are held on strong iron brackets, securely screwed to a hard-wood top, which is perfectly smooth, and very useful for storing tied-up matter or for other purposes.

The Window Stand is a rearrangement of the Double Stand, so that it occupies a square area, and is very suitable for placing opposite a window.

| | |
|---|---------|
| New York Single Stand, with racks for 15 cases | \$ 6 50 |
| New York Double Stand, with racks for 30 cases | 10 50 |
| New York Quadruple Stand, with racks for 60 cases | 18 00 |
| New York Window Stand, with racks for 30 cases | 10 50 |

CASE RACKS.

Made of hard wood, bolted together, and the higher racks are braced at the center with iron rods to prevent spreading.

| Full-size Cases. | Height. | |
|------------------------------------|---------------------|---------|
| Single, to hold 10 cases | 38 inches | \$ 5 50 |
| Single, to hold 16 cases | 50 inches | 7 00 |
| Single, to hold 20 cases | 60 inches | 8 00 |
| Single, to hold 24 cases | 70 inches | 9 00 |
| Single, to hold 30 cases | 84 inches | 10 00 |
| Double, to hold 40 cases | 60 inches | 14 00 |
| Double, to hold 60 cases | 84 inches | 18 00 |

Made to hold two-third and three-quarter cases at same prices. In ordering for two-third cases it is necessary to state exact width of cases, as there are two widths of two-third cases in use.

WOOD-TYPE CASE RACK.

Single, to hold 20 No. 3 Wood-Type Cases \$9 00
 A No. 3 Wood-Type Case is 23x44 inches over all.

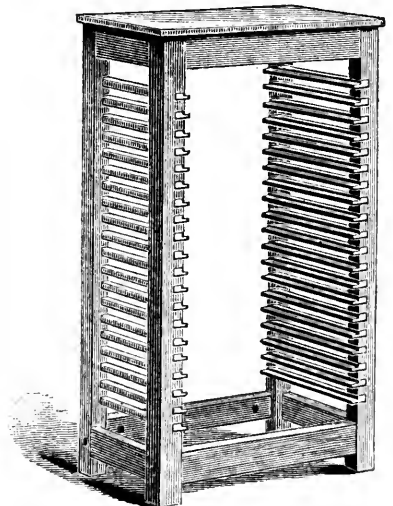

Case Rack for Twenty Full-size Cases.

“AMERICAN-POLHEMUS” CABINETS.

All Hard Wood.

The object of the American-Polhemus Cabinet is to save time and space. Time is lost on the ordinary cabinets by stationing the compositor in front of twenty cases, all frequently in use by other men, who, when setting or distributing from them, keep the man at the cabinet idle. On the American-Polhemus Cabinets the job cases are unobstructed, and the compositor stands at the back, where he cannot be interrupted. If he is setting solid matter he can empty his sticks, without walking a step, on a galley kept under his lower case, as the cases are held by the Patent Tilting Bracket and Galley Rest. Illustrated on page 944.

Every inch of space on the American-Polhemus Cabinets is utilized to advantage. The galley top or bank is a most useful addition. The space between the cases is used as a sort of a galley cabinet. The top is flat, and tied-up matter may be kept on it, as the iron case brackets admit of easy access to the space under the cases and galley top. The brackets which hold the cases project into the alley eight inches, giving the compositor plenty of knee-room, while saving floor-space.

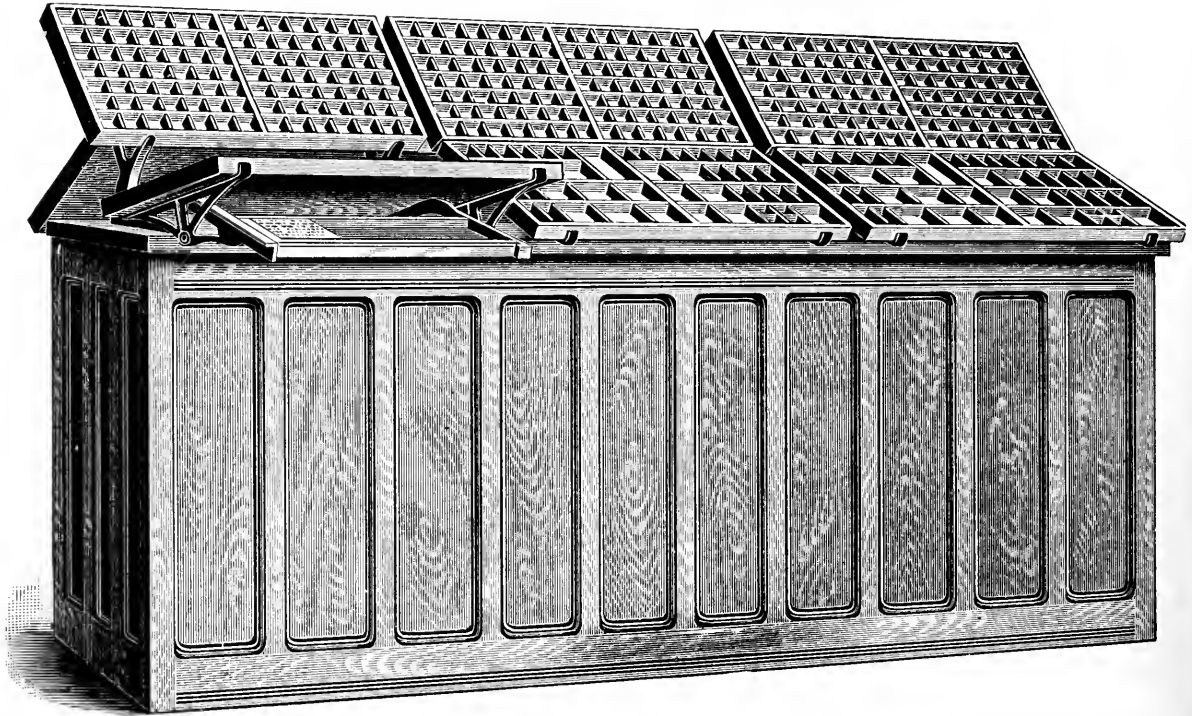

Back of American-Polhemus Triple Cabinet, showing arrangement of Body-letter Cases on the Patent Tilting Brackets.

PRICES OF AMERICAN-POLHEMUS CABINETS.

- No. 2. Single American-Polhemus Cabinet—Complete with 18 full-size California job cases, 1 pair of news cases, galley top, and 1 pair of patent tilting brackets \$35 00
- No. 1. Double American-Polhemus Cabinet—Complete with 18 full-size California and 20 two-third job cases, 2 pairs of news cases, galley top, 10 sort drawers or galley cabinet, and 2 pairs of patent tilting brackets 75 00
- No. 3. Triple American-Polhemus Cabinet—Complete with 18 full-size California and 40 two-third job cases (20 in a tier), 3 pairs news cases, galley top, 10 sort drawers and galley cabinet, and 3 pairs of patent tilting brackets . . . 110 00

STEEL-RUN AMERICAN-POLHEMUS CABINETS.

All Hard Wood.

These cabinets are similar to the American-Polhemus Cabinets, illustrated on these pages, except that the use of steel runs instead of wood runs increases their case-holding capacity without changing floor space or height.

- No. 4. Triple Polhemus Cabinets—Complete with 50 two-third and 25 full-size California job cases in three tiers (25 in a tier), 3 pairs news cases, galley top, 10 sort drawers and galley cabinet, and three pairs of patent tilting brackets. \$140 00
- No. 5. Double American-Polhemus Cabinet—Contains 25 full-size California job, 25 two-third job, and 2 pairs of full-size news cases on top, 10 sort drawers or galley cabinet, a galley top, and 2 pairs of patent tilting brackets 95 00
- No. 6. Double American-Polhemus Cabinet—Contains 50 full-size California job (25 in a tier), and 2 pairs of full-size news cases on top, a galley top, and 2 pairs of patent tilting brackets (*without sort drawers or galley cabinet*) . . . 95 00
- No. 7. Single American-Polhemus Cabinet—Contains 25 full-size California job, 1 pair of full-size news cases on top, a galley top, and 1 pair of patent tilting brackets 47 00

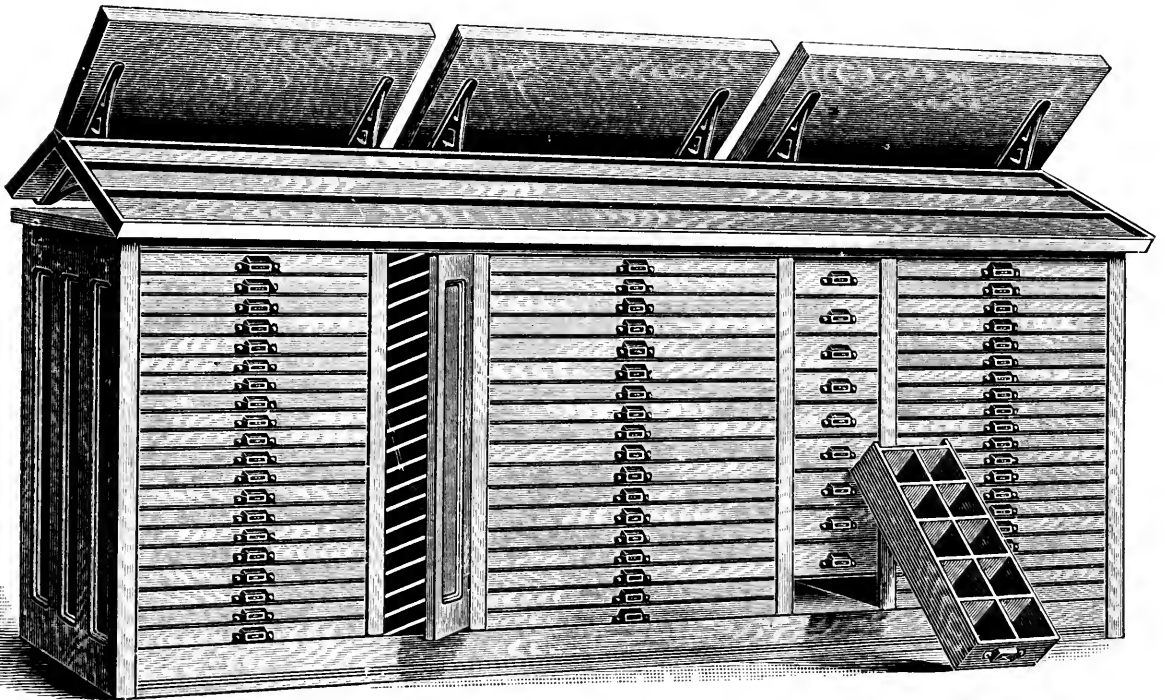

Front view of No. 3 Triple Polhemus Cabinet, showing Jobbing Cases, Sort Drawers, Galley Cabinet, and Galley Top on Bank.

CHOICE OF CASES.

Full-size California and two-third job cases will be furnished unless otherwise specified. Triple, regular job or italic, cap or lower cases, can be furnished, if desired, at the same prices. If rule, border or script cases are ordered, the difference in cost of cases will be added to the list price.

In Double Polhemus Cabinets Nos. 1 and 5 be sure and state which you prefer—sort drawers or galley cabinet.

Cabinets are constructed of ash, with antique oak finish.

WISCONSIN WINDOW CABINET.

All Hard Wood.

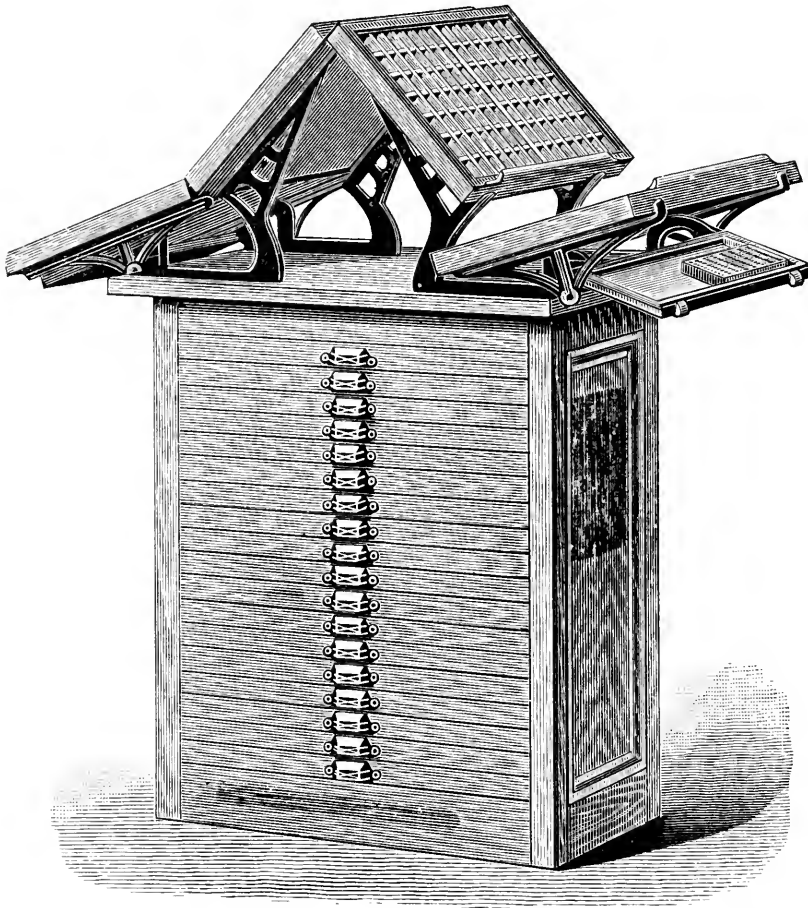

Specially designed for placing in front of a window, as it does not obstruct the light, of which the cases on top get the full benefit. Two men may work undisturbed at the sides, while the job cases in front are convenient for other men. The top is flat, and useful for holding tied-up type.

These cabinets have the patent tilting bracket and galley rest, which enables a compositor to empty his stick without leaving the cabinet by simply tilting his lower case, as shown in the cut, thus exposing the galley.

Weight, crated, about 375 pounds. Width, 35¾ inches ; height, 44 inches ; depth, 20½ inches.

No. 1. Wisconsin Window Cabinet, with 2 pairs of patent tilting brackets, 18 full-size California job cases, and 2 pairs of news cases on top \$36 00

No. 2. Wisconsin Window Cabinet, with 2 pairs of patent tilting brackets, 23 full-size cases and steel runs, and 2 pairs of news cases on top, same height as No. 1, 47 00

PATENT TILTING CASE BRACKET.

Used on Wisconsin Window and American-Polhemus Cabinets.

B B (outline) shows bracket holding case in position for setting. Shaded cut shows bracket tilted up, allowing compositor to empty on galley below lower case, which is more clearly shown in cut of Wisconsin Window Cabinet printed above. These brackets are also supplied with all American-Polhemus Cabinets.

Per pair \$2 00

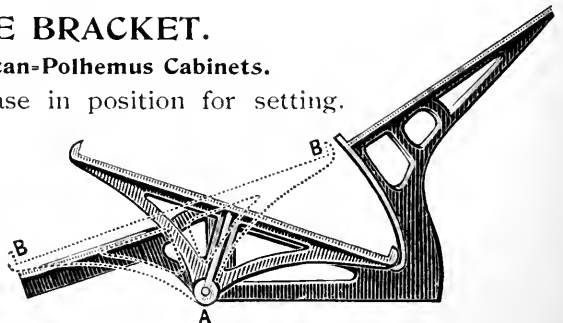

WISCONSIN HARD-WOOD CABINETS

With "New Departure" Cases.

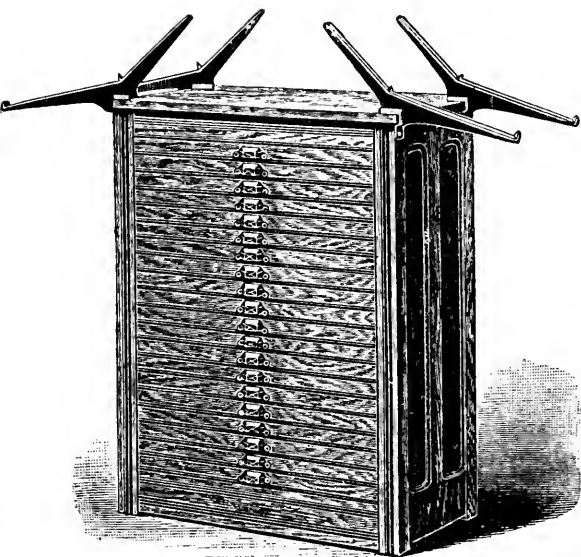

Twenty-Case Wisconsin Cabinet with Flat Top, showing Double Case Bracket, Style A*, attached to top, for holding two pairs of cases.

See page 1059 for prices of Double Case Brackets, Style A.

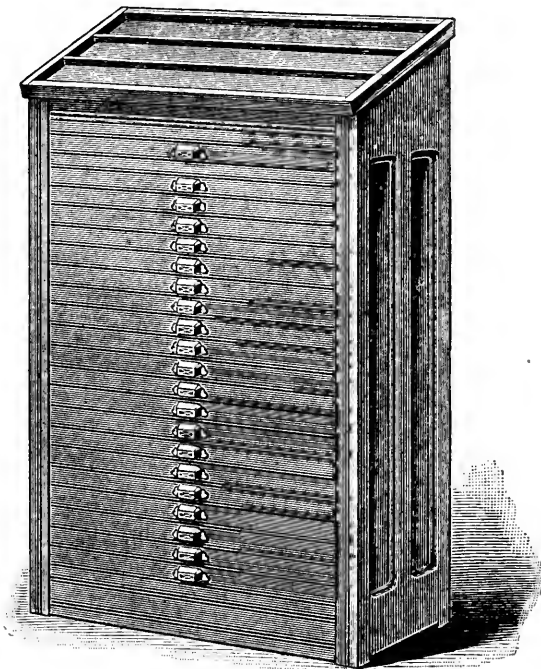

Twenty-Case Wisconsin Cabinet with Galley Top and Copy Drawer.

Although made of hard wood, these cabinets are sold at the same prices as ordinary cheap-looking stained cabinets. Three-quarter and full-size cabinets are furnished with California job cases, described on page 936, which are preferable to italic cases, as they afford more room for the caps. The bottoms are made flush with the floor, to prevent pi from getting underneath. The sides are double paneled and very tastefully moulded. Double case brackets may be put on top of the flat-top cabinets, making a very convenient stand, the regular height from the floor. *Galley-top cabinets are kept in stock with twenty cases only, but can be furnished for twelve and sixteen cases to order, though not recommended.*

LIST PRICES.

| | Flat Top. | Galley Top. |
|--|-----------|-------------|
| No. 19. With 12 two-third job cases | \$15 00 | . . . |
| No. 20. With 16 two-third job cases | 18 00 | . . . |
| No. 21. With 20 two-third job cases | 21 00 | \$24 00 |
| No. 22. With 12 three-quarter California job cases | 18 00 | . . . |
| No. 23. With 16 three-quarter California job cases | 22 00 | . . . |
| No. 24. With 20 three-quarter California job cases | 26 00 | 29 00 |
| No. 25. With 12 full-size California job cases | 22 00 | . . . |
| No. 26. With 16 full-size California job cases | 26 00 | . . . |
| No. 27. With 20 full-size California job cases | 30 00 | 33 00 |

See page 953 for Blank Case Cabinets.

OPTION :—Purchasers desiring special assortment of cases in lieu of the California job case, can make selection to suit their requirements. If higher-priced cases are selected, the difference in price is added to the list price of the cabinet.

AMERICAN STEEL-RUN CABINETS

Hold 50 per cent. more type in same floor space occupied by Regular 20-Case Cabinets.

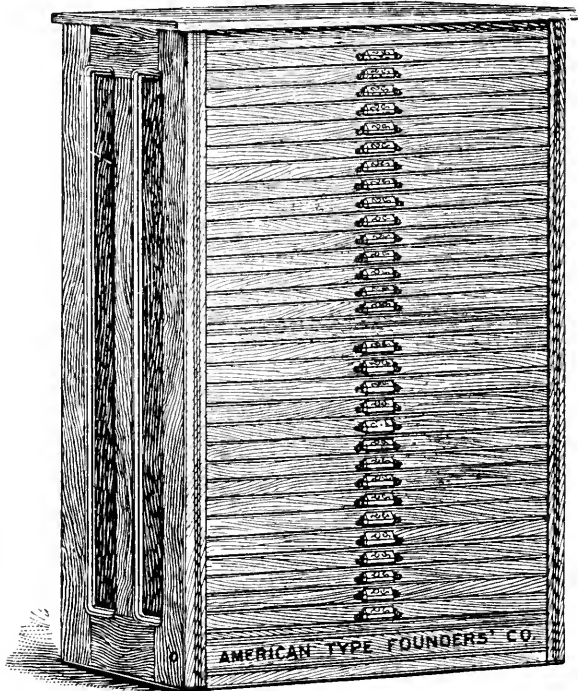

By substituting steel for wood in the runs, the awkward upper projections on the fronts of regular cabinet cases (which in the ordinary are put on to hide the wooden runs) are dispensed with, and ten more cases are got into the same space. Cases are easier to set out of, and *all cases are within easy reach of compositors of average height.*

The cabinets are made of hard wood, polished, braced in center to prevent spreading, and California job cases (giving one-third more room for caps by dispensing with two superfluous rows of boxes) are used instead of italic cases.

The height of the 30-case cabinets is 53 inches ; of the 40-case, 68 inches.

The illustration herewith shows the steel run used in American cabinets. Screws are countersunk.



Shows Steel-Run with Countersunk Screws.

LIST PRICES.

| | Flat Top. |
|--|-----------|
| 30-case American Steel-Run Cabinet, with 30 two-third job cases | \$35 00 |
| 30-case American Steel-Run Cabinet, with 30 full-size California job cases | 45 00 |
| 40-case American Steel-Run Cabinet, with 40 two-third job cases | 48 00 |
| 40-case American Steel-Run Cabinet, with 40 full-size California job cases | 60 00 |

OPTION.—Purchasers desiring special assortment of cases in lieu of the California job case, can make selection to suit their requirements. If higher-priced cases are selected, the difference in price is added to the list price of the cabinet.

**WISCONSIN CABINETS WITH STEEL RUNS.
FILLED WITH "NEW DEPARTURE" CASES.**

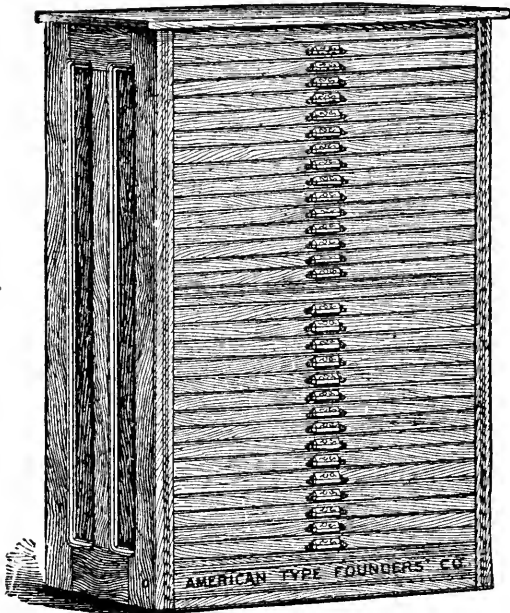

The merits of the modern Steel Run Cabinets have met with general recognition, and the best offices are now being equipped with these economical additions to the printing office. Where rents are high and space is limited these cabinets are especially recommended. They save twenty-five per cent. in space in the smaller sizes, and by using the high cabinets containing forty, fifty and sixty cases the saving is enormous. Space is utilized in the upper part of these high cabinets that was not occupied before. The same result is obtained by using high cabinets that is obtained in the eighteenth-story office building.

The Capacity is Enormously Increased while the Ground Space Occupied Remains the Same.

Every case is easily accessible, because the ones at the top of the high cabinets can be taken out and brought down to the proper level.

See illustration of steel-run with countersunk screws on opposite page.

DIMENSIONS OF STEEL RUN CABINETS.

| | Weight Full Size. | Height. | | Weight Full Size. | Height. |
|------------------|-------------------|-------------------------|-------------------------|-------------------|-------------------------|
| 20-case cabinets | . . . 250 lbs. | 37 $\frac{3}{4}$ inches | 40-case cabinets | . . . 475 lbs. | 68 inches |
| 25-case cabinets | . . . 300 lbs. | 44 $\frac{1}{4}$ inches | 50-case cabinets | . . . 575 lbs. | 84 inches |
| 30-case cabinets | . . . 350 lbs. | 53 inches | 60-case cabinets | . . . 650 lbs. | 99 inches |
| | | | | | |
| | | Full Size. | Three-quarter Size. | | Two-third Size. |
| Depth | | 20 $\frac{3}{8}$ inches | 19 $\frac{3}{8}$ inches | | 19 $\frac{3}{8}$ inches |
| Width | | 35 $\frac{3}{4}$ inches | 29 $\frac{3}{4}$ inches | | 25 $\frac{1}{4}$ inches |

PRICE LIST OF WISCONSIN STEEL RUN CABINETS.

| No. | Description | With Two-third Job Cases and Three-quarter and Full-size California Job Cases. | | With Blank Cases for Electrotypes. | |
|---------|--|--|-------------|------------------------------------|-------------|
| | | Flat Top. | Galley Top. | Flat Top. | Galley Top. |
| No. 1. | With 20 two-third cases | \$25 00 | \$28 00 | \$21 00 | \$24 00 |
| No. 2. | With 25 two-third cases | 30 00 | 33 00 | 25 00 | 28 00 |
| No. 3. | With 30 two-third cases | 35 00 | . . . | 29 00 | . . . |
| No. 4. | With 40 two-third cases | 48 00 | . . . | 40 00 | . . . |
| No. 5. | With 50 two-third cases | 60 00 | . . . | 50 00 | . . . |
| No. 6. | With 60 two-third cases | 72 00 | . . . | 60 00 | . . . |
| No. 7. | With 20 three-quarter cases | 30 00 | 33 00 | 26 00 | 29 00 |
| No. 8. | With 25 three-quarter cases | 35 00 | 38 00 | 30 00 | 33 00 |
| No. 9. | With 30 three-quarter cases | 40 00 | . . . | 34 00 | . . . |
| No. 10. | With 40 three-quarter cases | 53 00 | . . . | 45 00 | . . . |
| No. 11. | With 50 three-quarter cases | 65 00 | . . . | 55 00 | . . . |
| No. 12. | With 60 three-quarter cases | 78 00 | . . . | 66 00 | . . . |
| No. 13. | With 20 full size cases | 35 00 | 38 00 | 31 00 | 34 00 |
| No. 14. | With 25 full size cases | 40 00 | 43 00 | 35 00 | 38 00 |
| No. 15. | With 30 full size cases | 45 00 | . . . | 39 00 | . . . |
| No. 16. | With 40 full size cases | 60 00 | . . . | 52 00 | . . . |
| No. 17. | With 50 full size cases | 75 00 | . . . | 65 00 | . . . |
| No. 18. | With 60 full size cases | 90 00 | . . . | 78 00 | . . . |
| | Double Case Brackets, per pair | | | | 1 25 |

Nos. 2, 8 and 14 are correct height to use with patent tilting brackets, in same manner as on Polhemus cabinets shown on page 944.

The Fifty-case and Sixty-case cabinets are furnished in one or two tiers, as desired. Brass label holders attached to any cabinet at an additional price of five cents per case list.

PORTER'S PATENT EXTENSION-FRONT STEEL-RUN CABINET.

The sides of these cabinets are extended four inches beyond the fronts of the cases. These extensions serve the printer in two ways: (1) A case near the top of a cabinet may be taken from its rack and placed in a more convenient position for setting from, and will be held by the extensions without withdrawing another case. (2) The extensions permit cases to be drawn out further from the racks than is possible in other cabinets, making it easier to set out of the rear boxes. In addition, these cabinets have all the best points of other cabinets, such as steel runs, "New-Departure" cases, hard wood throughout, and are stronger than any other cabinets. The extension sides make it practicable to use higher cabinets, containing more cases in a tier, than can be advised where ordinary cabinets are used.

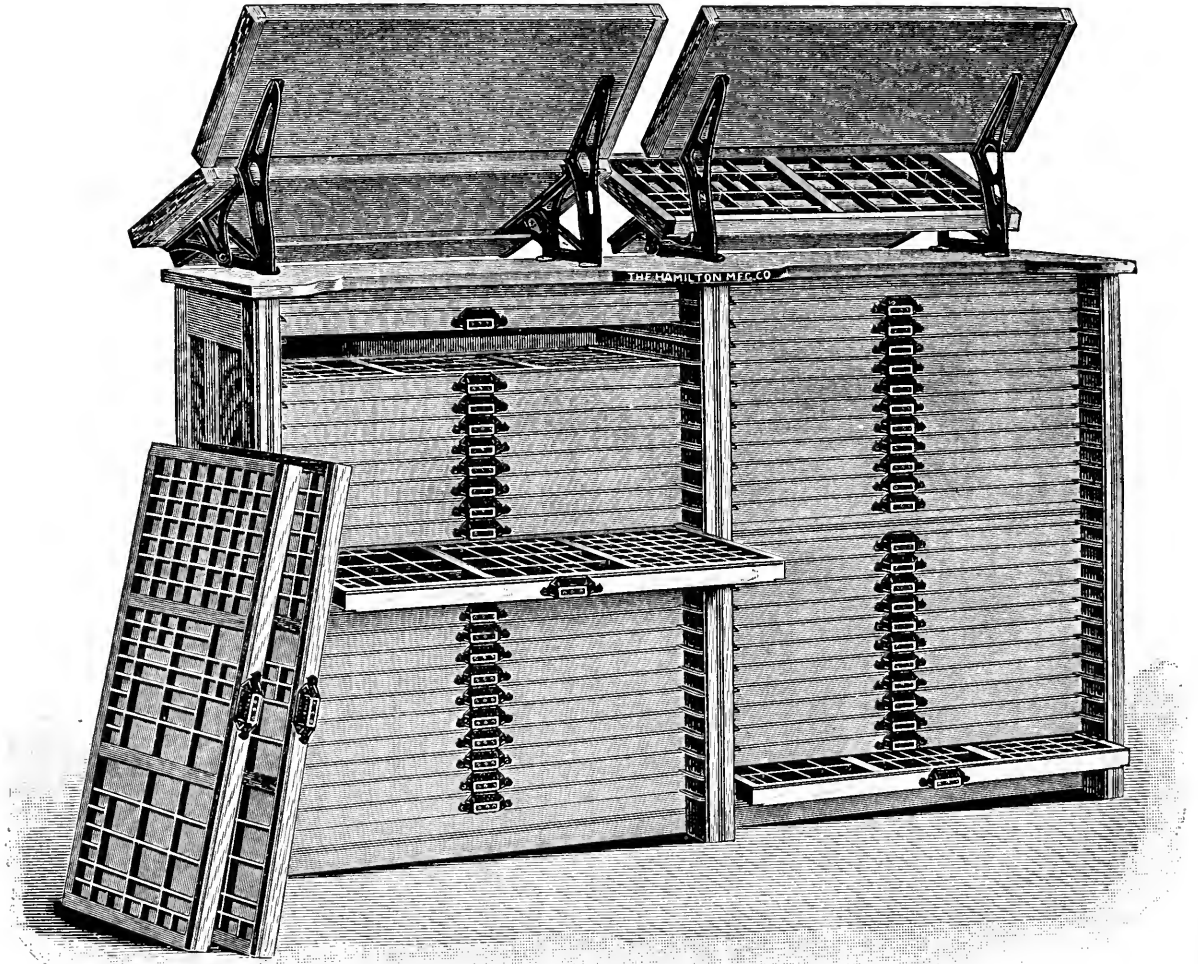

No. 7 Porter Steel-Run Cabinet.

LIST PRICES.

| | Height Inches. | With Full-size California Job Cases—Flat Top. | With Full-size Blank Cases for Electrotypes. |
|---|-------------------|---|--|
| No. 1. 25 cases, single tier | 46 | \$43 00 | \$38 00 |
| No. 2. 30 cases, single tier | 53 | 51 00 | 45 00 |
| No. 3. 40 cases, single tier | 68 | 68 00 | 60 00 |
| No. 4. 50 cases, single tier | 84 | 85 00 | 75 00 |
| No. 4. 50 cases, double tiers | 46 | 85 00 | 75 00 |
| No. 5. 60 cases, single tier | 99 | 100 00 | 90 00 |
| No. 5. 60 cases, double tiers | 53 | 100 00 | 90 00 |
| No. 6. 23 cases, single tier, with one pair tilting brackets and one pair news cases on top . | 43 | 45 00 | . . . |
| No. 7. 46 cases, double tier, with two pair tilting brackets and two pairs news cases on top . | 43 | 90 00 | . . . |

These cabinets are 35½ inches wide and 22 inches deep. Depth of the extension front is 4 inches. FOR OPTION ON CASES, see page 946.

ROWEN BORDER AND SCRIPT TYPE CABINETS.

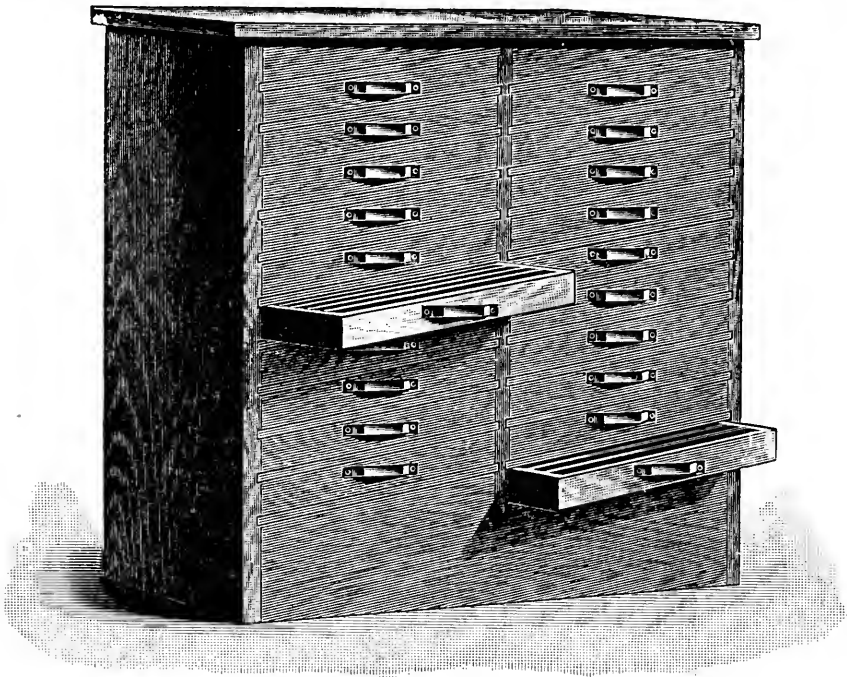

Rowen Border Cabinet with Twenty Cases.

These cabinets supply the long-felt need of a proper receptacle for borders, keeping them in compact shape and preserving the face.

The cases in these cabinets are 10×12 inches inside, and are tilted sufficiently to keep the type on its feet. The borders or type are held between movable division strips, which are 18 points wide, while the slots into which these strips fit are set 6 points apart, so that they can be adjusted to hold 6, 12, 18, 24, 30, 36, 42, 48, 54, 60, or 72 point bodies, while such irregular and seldom-used bodies as 8 and 9 point may be carried in the 12-point drawers, or special strips may be procured for them.

For script type a quantity of metal pinch springs is furnished with each cabinet, for inserting between the different letters in a font, so that if all the letters "d" are removed, the pinch spring holds the letters "e" on their feet. The advantages of keeping delicate scripts in cases where the faces of the letters are not subject to friction and scratching will be apparent to all.

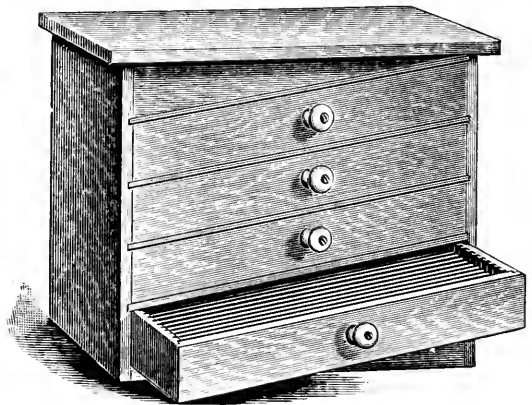

Rowen Border and Script Type Cabinet with Four Drawers.

LIST PRICES.

| | |
|--|---------|
| No. 1. 4 drawers, one tier, height 12 inches | \$ 8 00 |
| No. 2. 6 drawers, one tier, height 16 inches | 10 50 |
| No. 3. 10 drawers, one tier, height 25 inches | 16 00 |
| No. 4. 16 drawers, two tiers, height 21 inches | 25 00 |
| No. 5. 20 drawers, two tiers, height 25 inches | 30 00 |
| No. 6. 30 drawers, two tiers, height 35 inches | 45 00 |
| No. 7. 40 drawers, two tiers, height 44 inches | 60 00 |

Each case will hold 30 feet of 6-point, or 24 feet of 12-point, or 20 feet of 18-point, or 17 feet of 24-point, or 15 feet of 30-point, or 13 feet of 36-point borders.

HANDY SORT CABINETS.

These cabinets are fitted with serviceable sort drawers which should supplant the various cigar-box-tin-can arrangements which disgrace so many offices. The drawers are 8 × 20 inches over all, and 2½ inches deep. The cabinets are very strong, made of hard wood, and remarkably low-priced. The drawers, which are also for sale separately, have movable partitions, and may be adjusted to the special requirements of any printing office. All drawers have strong bronze drawer-pulls, whether sold in cabinets or separately.

A picture of the drawer is shown below. Drawers are sold separately if required.



Handy Sort Cabinet, with Thirty Drawers.

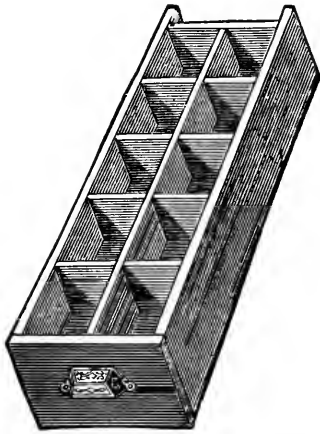

| | |
|--|-------------|
| Cabinet with 10 Handy Sort Drawers | \$12 00 |
| Cabinet with 20 Handy Sort Drawers | 23 00 |
| Cabinet with 30 Handy Sort Drawers | 35 00 |
| Cabinet with 40 Handy Sort Drawers | 47 00 |
| Cabinet with 50 Handy Sort Drawers | 59 00 |
| HANDY SORT DRAWERS, each | 0 90 |

Sort cabinets made to order to fit any space, or to any dimensions, at proportionate prices.

PAPER AND CARD STOCK CABINETS.

Made very strongly of hard wood. High-priced papers and cardboard should be kept in a dust-tight receptacle, to prevent wastage and economize space. The drawers have extension backs, and are strongly constructed.

No. 1. 12 drawers, each drawer holding 22½ × 28-inch cardboard, or smaller.

Price \$37 00

No. 2. 12 drawers, each drawer taking full sheet of 28 × 42 inches.

Price \$48 00

The cabinets are 48 inches high. The drawers are 2½ and 5 inches deep, and have movable partitions.



No. 1 Paper Stock Cabinet. Occupies 26 × 34 inches floor space.

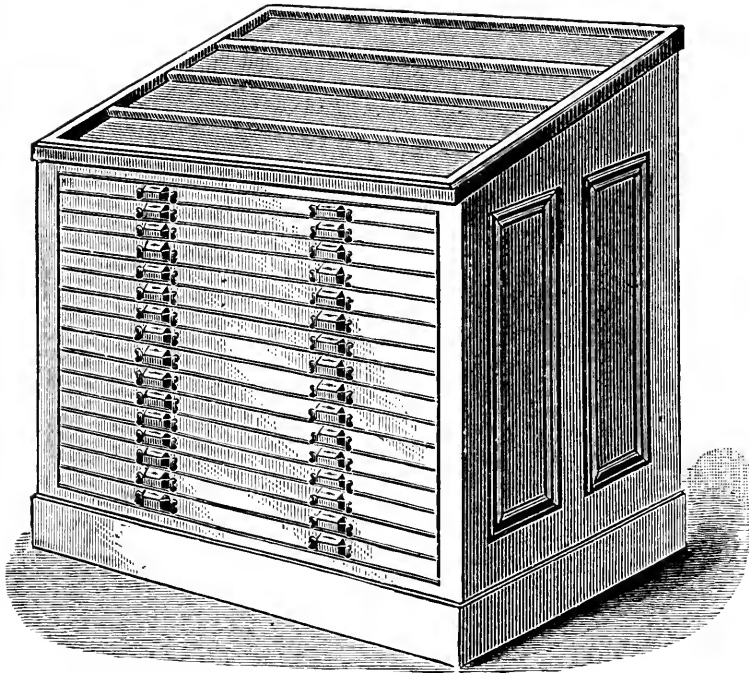

No. 5 Wood-Type Cabinet, with Galley Top. Occupies nine square feet floor space, and affords one hundred and twelve square feet for storage of type.

WOOD-TYPE CABINETS.

Very substantially constructed of hard wood. The cases are slotted on the sides, and have movable strips which may be adjusted to Picas. The cases in the Mammoth Cabinet (23 X 44 inches) have a center bar, and cases in the Regular Cabinet (23 X 32 inches) have no center bar.

These cabinets afford the most economical method of keeping wood type. The top of cabinet is available for use in laying out lines. They save the time lost in climbing to shelves, and the wood type is kept clean and is less liable to warp.

| | Flat Top. | Galley Top. |
|---|-----------|-------------|
| No. 1. 12 cases, 23 X 32 inches | \$24 00 | \$27 50 |
| No. 2. 16 cases, 23 X 32 inches | 30 00 | 33 50 |
| No. 3. 20 cases, 23 X 32 inches | 36 00 | 39 50 |
| No. 4. 12 cases, 23 X 44 inches | 30 00 | 34 00 |
| No. 5. 16 cases, 23 X 44 inches | 40 00 | 44 00 |
| No. 6. 20 cases, 23 X 44 inches | 48 00 | 52 00 |

WOOD-TYPE CASE RACK.

To hold twenty No. 3 wood-type cases (made to order) \$9 00

For prices of wood-type cases, see page 937. No. 3 Wood-type cases are 23 X 44 inches over all, and the price is \$1 30 each.

BOOKBINDERS' CABINETS.

Made of hard wood, with bronzed pulls on each case. The cases are made in exactly the same style as printers' cases. These cabinets occupy a space of 20 X 20 inches, and may be put on or under a bench. "A place for everything and everything in its place" is a rule bookbinders should live up to, and these cabinets enable them to do so.

- Cabinets with 6 cases . \$ 8 00
- Cabinets with 10 cases . 12 00
- Cabinets with 15 cases . 16 50

BOOKBINDERS' CASE.

Half cap case, 16 X 16 1/4 inches, without bronze pull, each \$0 60



Case used in Bookbinders' Cabinet.

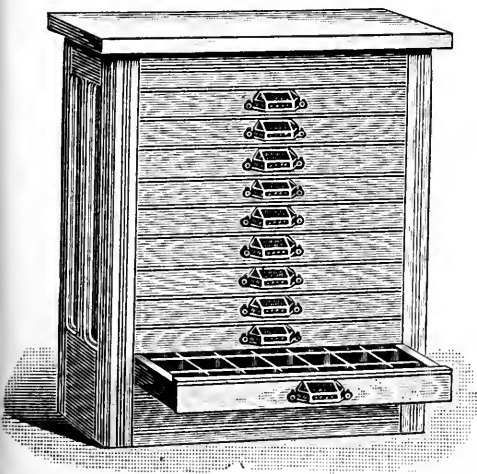

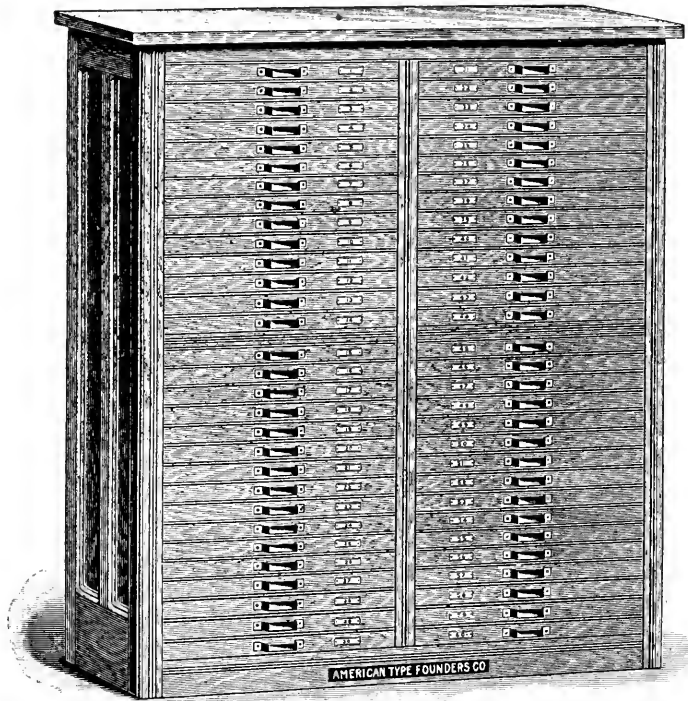

INDEXED ELECTROTYPE CABINET.

Fitted with the special cases illustrated below, each furnished with strong adjustable slotted partitions, each case numbered in front, and each section in the case designated by initial label, for which a secure holder is provided. The cuts in each lengthwise section are separated and held in place by shallow crosswise slats. An Index Book is furnished with each cabinet in which the cuts are indexed as follows:

| ORIGINAL CUT | | | NAME OF CUT | ELECTROTYPES | | | | |
|--------------|---------|----------|----------------|--------------|---------|-----------|---|---|
| DRAWER | SECTION | DIVISION | | DRAWER | SECTION | DIVISIONS | | |
| 12 | D | 3 | Bicycle | 31 | E | 1 | 2 | 3 |
| 12 | A | 2 | Lawn Mower | 33 | A | 4 | 5 | 6 |
| 12 | E | 3 | Sewing Machine | 35 | B | 1 | 2 | 3 |
| 12 | D | 4 | Factory Plant | 30 | C | 7 | 8 | 9 |

Nos. 6, 12, and 18 Cabinets, containing 60 Cases.

These cabinets meet in every respect the requirements of not only printers but of all manufacturing concerns that use cuts largely. Printers will do a favor to their customers of this class by calling their attention to these new cabinets. They are substantially and handsomely made of ash, finished in antique oak. The cases slide on steel runs, so that they take up the least possible space. The dimensions, weight and prices are given on next page.

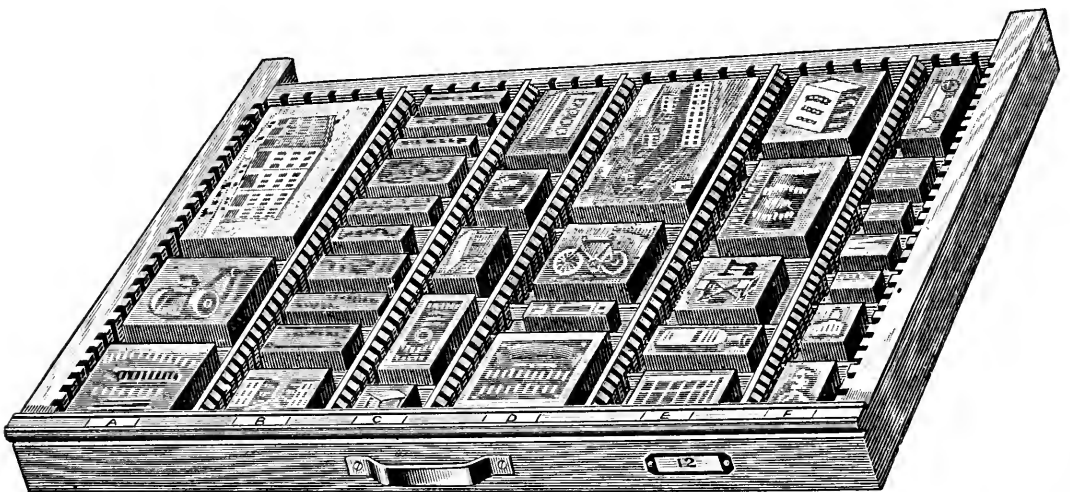

Case furnished in Indexed Electrotype Cabinets.

Note that every cut is in a distinct compartment, and that as many sections and divisions of sections can be made as are desired. The plan of the index printed above refers to the case shown here.

PRICE LIST OF INDEXED ELECTROTYPE CABINETS.

View of full-length Slotted Section Slats.

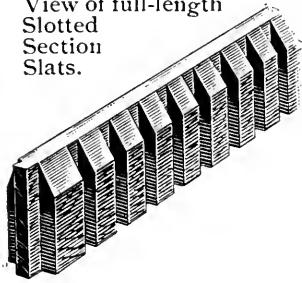

The Division Slats, which are shallow, fit into these Section Slats as shown in cut on preceding page.

| No. | Size of Cases Inches. | Height Inches. | Price. |
|-----|--|----------------|---------|
| 1. | With 20 two-third cases 16×21¾ | 38 | \$25 00 |
| 2. | With 25 two-third cases 16×21¾ | 45 | 30 00 |
| 3. | With 30 two-third cases 16×21¾ | 53 | 35 00 |
| 4. | With 40 two-third cases 16×21¾ | 68 | 48 00 |
| 5. | With 50 two-third cases 16×21¾ | 84 | 60 00 |
| 6. | With 60 two-third cases 16×21¾ | 99 | 72 00 |
| 7. | With 20 three-quarter cases 16×26¼ | 38 | 30 00 |
| 8. | With 25 three-quarter cases 16×26¼ | 45 | 35 00 |
| 9. | With 30 three-quarter cases 16×26¼ | 53 | 40 00 |
| 10. | With 40 three-quarter cases 16×26¼ | 68 | 53 00 |
| 11. | With 50 three-quarter cases 16×26¼ | 84 | 65 00 |
| 12. | With 60 three-quarter cases 16×26¼ | 99 | 78 00 |
| 13. | With 20 full-size cases 16×32¼ | 38 | 35 00 |
| 14. | With 25 full-size cases 16×32¼ | 45 | 40 00 |
| 15. | With 30 full-size cases 16×32¼ | 53 | 45 00 |
| 16. | With 40 full-size cases 16×32¼ | 68 | 60 00 |
| 17. | With 50 full-size cases 16×32¼ | 84 | 75 00 |
| 18. | With 60 full-size cases 16×32¼ | 99 | 90 00 |

The fifty-case and sixty-case cabinets are furnished in one or two tiers, as desired.

SPECIAL NOTICE.—The above prices include the cabinets fitted with a full equipment of division slats, including five of the slotted section divisions for each drawer in the two-third size cases, and six for each drawer in the three-quarter and full-size cases; also with a large assortment of cross divisions, in various lengths. Each drawer is fitted with a metal number plate, as shown in the illustrations on preceding page. One index book is furnished with each cabinet.

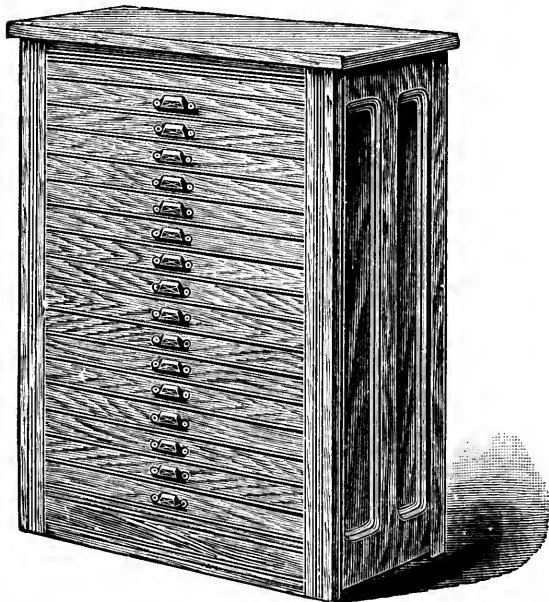

ELECTRO AND CUT CABINETS.

These cabinets are filled with blank cases, and are made of polished ash, with bronze case-pulls. The cases have extension backs. In addition to the ordinary use of the printer, these cabinets can be recommended to advertisers for keeping their wood cuts, etc., for keeping samples of hardware, confectionery, fancy stationery, for seeds, and for many other purposes.

All sizes can be supplied with galley tops at an advance of \$3.00 on flat-top prices, but galley tops are not recommended except on 20-case cabinets.

Flat-Top Sixteen-Case Electro Cabinet.

| No. | Size of Cases Inches. | Height of Cabinet. | With Flat Top. | Galley Top. |
|--------|---|--------------------|----------------|-------------|
| No. 1. | 12 two-third blank cases 16×21¾ | 34½ inches | \$12 00 | |
| No. 2. | 16 two-third blank cases 16×21¾ | 43 inches | 14 00 | |
| No. 3. | 20 two-third blank cases 16×21¾ | 43 inches | 16 00 | \$19 00 |
| No. 4. | 12 three-quarter blank cases 16×26¼ | 34½ inches | 15 00 | |
| No. 5. | 16 three-quarter blank cases 16×26¼ | 43 inches | 18 00 | |
| No. 6. | 20 three-quarter blank cases 16×26¼ | 43 inches | 21 00 | 24 00 |
| No. 7. | 12 full-size blank cases 16×32¼ | 34½ inches | 19 00 | |
| No. 8. | 16 full-size blank cases 16×32¼ | 43 inches | 22 00 | |
| No. 9. | 20 full-size blank cases 16×32¼ | 43 inches | 25 00 | 28 00 |

See page 946 for prices of Steel Run Cabinets with Blank Cases. Also page 948 for prices of Porter Extension-Front Cabinets with Blank Cases.

HANDY LETTER BOARD CABINETS.

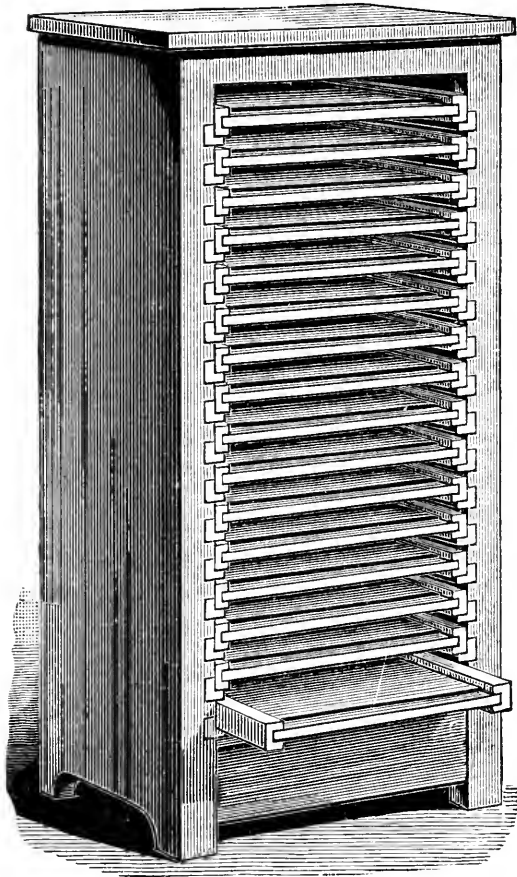

Handy Letter Board Cabinet with Sixteen Boards.

For the storage and safe keeping of job work these cabinets are unrivaled. Their cost will be saved in a few months by the prevention of pi. They occupy a floor space of 16×19 inches, with letter boards of 12×15 inches inside, and are made of hard wood throughout, in a solid and substantial manner. Boards are closed at sides and back, and are rabbeted in front to receive galleys. They are well-named "Handy." For job work within their size—and this the larger variety of such work—these small boards are much superior to the larger boards usually put under imposing tables, as it is a back-breaking job to get a form from these large boards when they are full of type.

It is distinctly an economy to place dead and live forms in such a receptacle as this, rather than to incumber useful space on an imposing stone, the type on which is always liable to damage. The protection they afford from dust is also worthy of consideration.

| | |
|--------------------------|---------|
| With 10 boards | \$10 50 |
| With 12 boards | 12 00 |
| With 16 boards | 15 00 |

Other sizes made to order at proportionate prices.

HARD-WOOD LETTER BOARDS.

Made of selected stock, smooth and true, with closed sides and backs, rabbeted in front to allow matter to slide on galleys easily. These boards have projecting backs so that they can be pulled out of the racks to the full extent of their inside measurements.

| | |
|---|--------|
| No. 1, 21¼×20½ inches outside, fits two-third case stands | \$1 20 |
| No. 2, 26¼×20½ inches outside, fits three-quarter stands | 1 40 |
| No. 3, 32¼×20½ inches outside, fits full-size stands or racks | 1 70 |

INK AND ROLLER CABINETS.

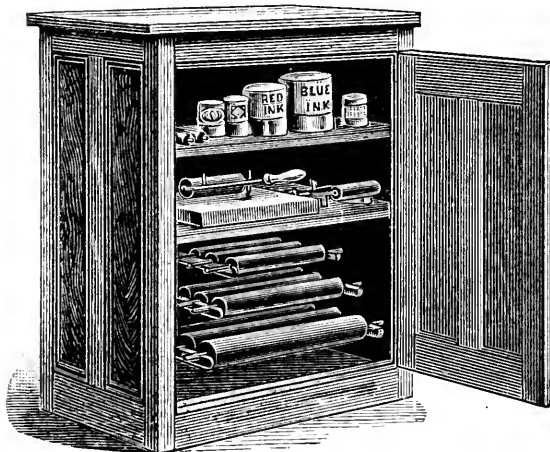

A very necessary article of printing-office furniture. The use of it will result in a saving of ink and rollers, which will speedily pay for the cost of cabinet.

| | |
|---|--------|
| No. 1, with shelf for ink, shelf for brayer and ink slab, and brackets to hold 6 eighth and 6 quarto rollers | \$6 50 |
| No. 2, with shelf for ink, shelf for brayers and ink slabs, and brackets for 6 each eighth, quarto and half-medium rollers | 9 50 |
| No. 3, with shelf for ink, shelf for brayers and ink slabs, and brackets to hold 12 each eighth, quarto and half-medium rollers | 13 00 |

GALLEY CABINETS.

Made of thoroughly seasoned Hard Wood, in the most substantial manner.

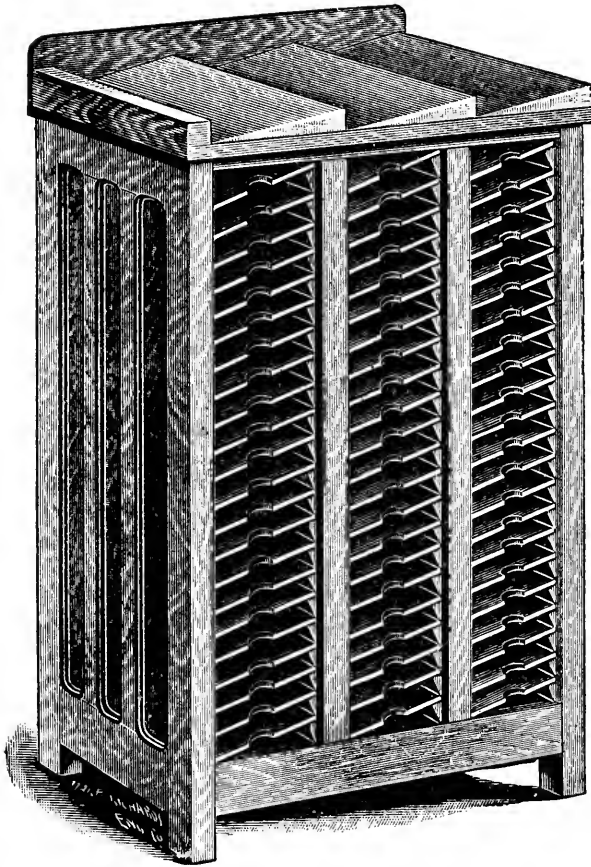

Three-tier Galley Cabinet with Galley Top, to hold Sixty-six Galleys.

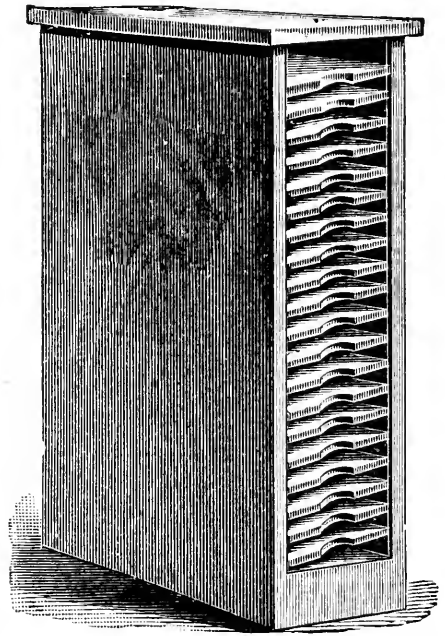

One-tier Flat-top Galley Cabinet, to hold Twenty Galleys.

Particular attention is directed to the galley cabinets of larger capacity. They are very desirable in the larger offices, and are designed to carry an immense weight of type safely. All these cabinets are made of hard wood. All flat-top cabinets are made same style as the one-tier cabinet illustrated above. All galley-top cabinets same as the three-tier cabinet shown on this page.

The "galley-top" cabinets are of much stronger construction than the "flat-top," and may be ordered with or without galley top, as desired, at the same prices.

| | With Flat Top. | With Galley Top. | Boxing. |
|---------------------------------------|----------------|------------------|---------|
| 1 tier to hold 20 galleys | \$ 8 00 | \$14 00 | \$0 50 |
| 1 tier to hold 30 galleys | 11 50 | . . . | 0 75 |
| 2 tiers to hold 40 galleys | 15 00 | 25 00 | 1 00 |
| 2 tiers to hold 50 galleys | 18 50 | . . . | 1 25 |
| 2 tiers to hold 60 galleys | 22 00 | . . . | 1 50 |
| 3 tiers to hold 66 galleys | . . . | 36 00 | 2 00 |
| 4 tiers to hold 88 galleys | . . . | 47 50 | 2 50 |
| 6 tiers to hold 132 galleys | . . . | 62 00 | 3 00 |
| 9 tiers to hold 198 galleys | . . . | 85 00 | 4 00 |

NOTE.—The shelves in the larger cabinets should be numbered, and the proof of the galley should be numbered to correspond with the number on shelf, thus saving all the time required to locate galleys that are not so numbered. Iron number plates, made for numbering shelves, can be supplied at the following prices, net :

| | | |
|--------------------------------|-------------------------------|-------------------------------|
| 1 tier (20 galleys) . . \$1 00 | 2 tiers (50 galleys) . \$1 75 | 4 tiers (88 galleys) . \$3 00 |
| 1 tier (30 galleys) . . 1 25 | 2 tiers (60 galleys) . 2 00 | 6 tiers (132 galleys) . 4 00 |
| 2 tiers (40 galleys) . 1 50 | 3 tiers (66 galleys) . 2 25 | 9 tiers (198 galleys) . 5 00 |

LINOTYPE MATRIX CABINET.

Has roll curtain front, with lock. Made of hard wood, beautifully finished, and very substantial. Each drawer is $14\frac{1}{4} \times 15$ inches inside, and holds 142 running inches of matrices set edgewise. A locked tool drawer, $4\frac{1}{2}$ inches deep, is placed at the bottom, which also holds the space bars on a brass rod.

- No. 1. 6 matrix and 1 tool drawers, height $29\frac{1}{2}$ ins. \$22 00
- No. 2. 8 matrix and 1 tool drawers, height 34 ins. 28 00
- No. 3. 10 matrix and 1 tool drawers, height $38\frac{1}{2}$ ins. 34 00
- No. 4. 12 matrix and 1 tool drawers, height 43 ins. 40 00

Six metal slugs, same shape and size as a matrix and $\frac{3}{4}$ -inch wide, furnished with each drawer. These hold up the matrices at ends of lines.

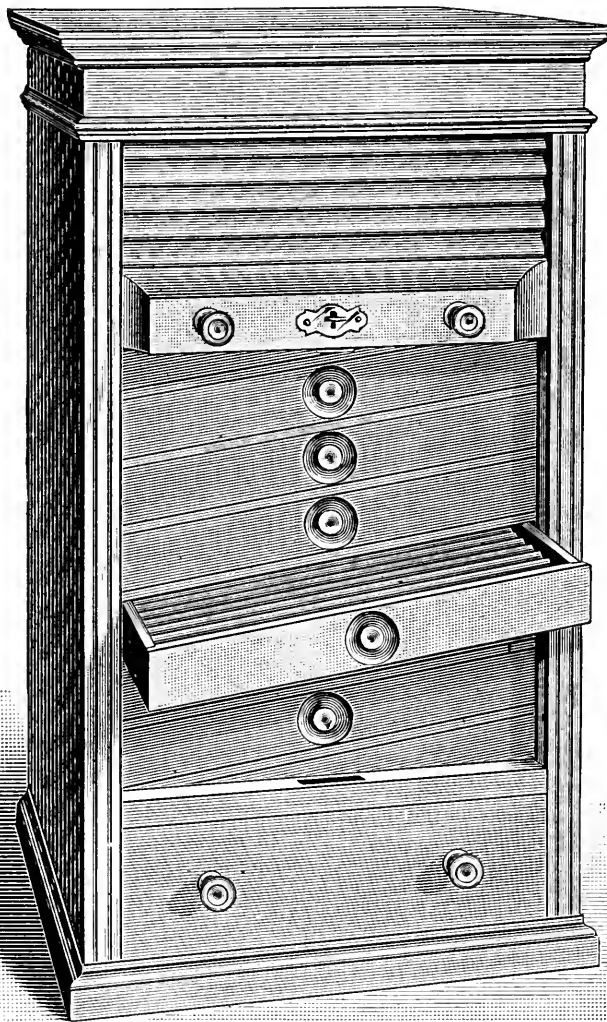

Eight-Drawer Linotype Matrix Cabinet.

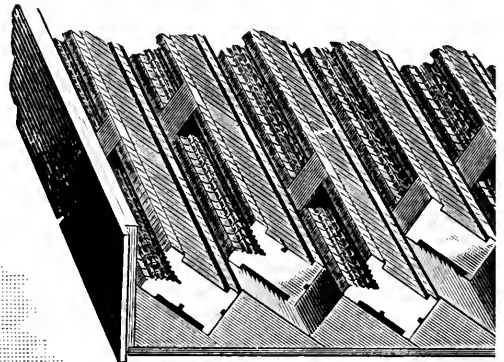

Detailed Section of Matrix Drawer, showing Matrices in place.

SPECIMEN CABINETS.

Made of ash. These cabinets are handsomely constructed, and will be an ornament to any office.

The drawers have movable partitions, and are made in two depths— $2\frac{1}{2}$ inches and 5 inches. The No. 1 cabinet is the proper height for placing a letter-copying press on.

The methodical classification and preservation of specimens in a cabinet enables customers to decide on what they want quickly, and in many cases suggests other requirements. Let the public see what you have to sell, and they will become buyers.

- No. 1. 8 drawers, 26 inches wide by 19 inches deep by 37 inches high \$14 00
- No. 2. 12 drawers, 26 inches wide by 19 inches deep by 53 inches high 20 00

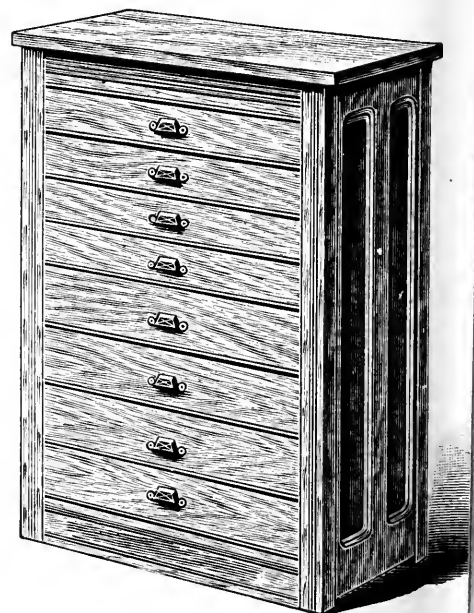

No. 1 Specimen Cabinet, 26 inches wide, 37 inches high, and 19 inches deep.

MOVABLE GALLEY RACKS.

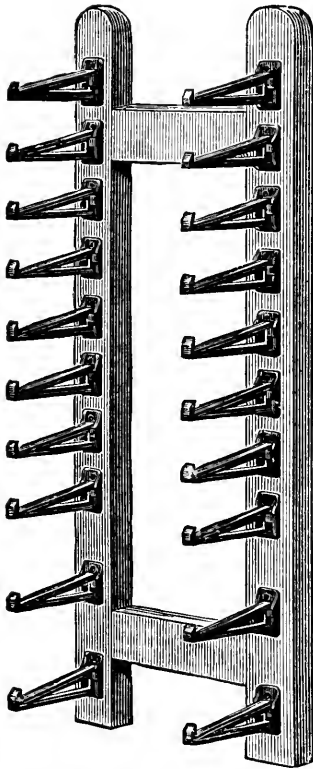

Regular Galley Rack with Movable Galley Brackets.

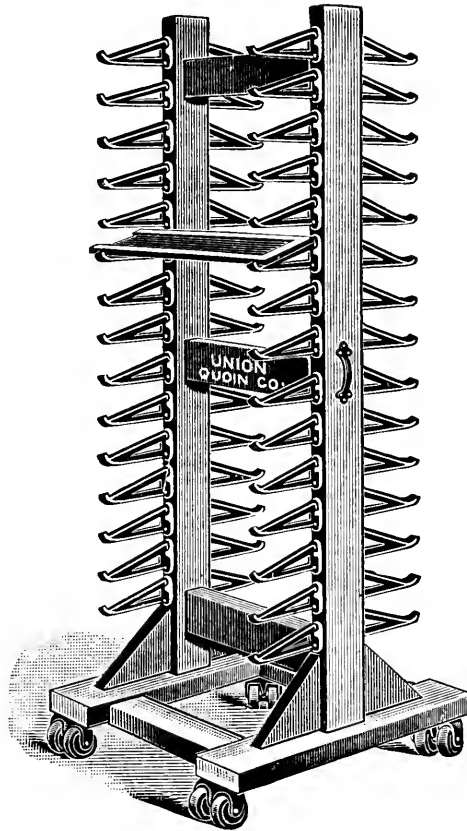

Union Movable Galley Rack.

UNION MOVABLE GALLEY RACK.

The Union Movable Galley Rack holds 30 galleys, and is mounted on strong casters so that it can be moved at will to the most convenient position for doing the work in hand. Union Movable Galley Rack, holding 30 galleys \$21 00

REGULAR GALLEY RACK.

The Regular Galley Rack is intended for placing against the wall. The brackets are secured on a very strong hard-wood frame.

| | |
|---|---------|
| Regular Galley Rack, for 6 galleys | \$ 3 00 |
| Regular Galley Rack, for 8 galleys | 4 00 |
| Regular Galley Rack, for 10 galleys | 5 00 |
| Regular Galley Rack, for 12 galleys | 6 00 |
| Regular Galley Rack, for 15 galleys | 7 50 |
| Regular Galley Rack, for 20 galleys | 10 00 |

GALLEY BRACKETS.

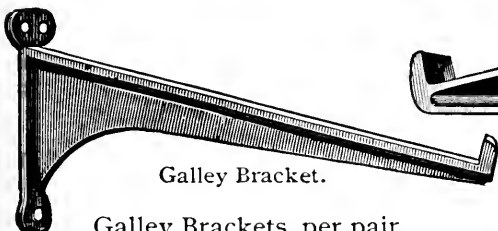

Galley Bracket.

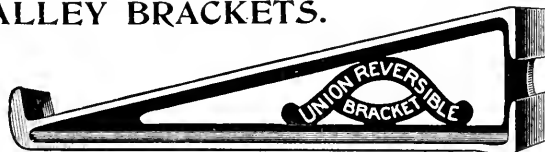

Union Reversible Galley Bracket and Socket.

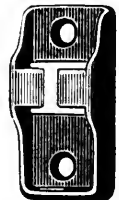

| | |
|--|--------|
| Galley Brackets, per pair | \$0 40 |
| Union Reversible Galley Brackets, with sockets, per doz. pairs, \$6 00; per pair | 0 60 |

WOOD FURNITURE, REGLET AND SIDE STICKS.

| | | | |
|---|-----------|------------------------------------|-----------|
| | Per yard. | | Per yard. |
| Pearl to Pica Reglet | \$0 02 | 6- to 9-line Furniture | \$0 06 |
| Gr. Primer Reglet to 2-line Furniture | 0 03 | 10- to 12-line Furniture | 0 08 |
| 3- to 5-line Furniture | 0 04 | 13- to 16-line Furniture | 0 10 |

SIDE STICKS, thin, medium or thick Per yard, \$0 06

**LABOR=SAVING
REGLET
CASES.**

Nos. 3, 4, 5, 6 are made same style as illustration.

The reglet lies flat, and varies by ems up to 51 ems, and by 5 ems in longer lengths. Nos. 1 and 2 are square boxes, in which reglet is put in on end, and varies by 10 ems up to 60 ems, with 72 and 120 ems added in the No. 2 case. One-half the pieces in each case are Pica body; the other half, Nonpareil body.

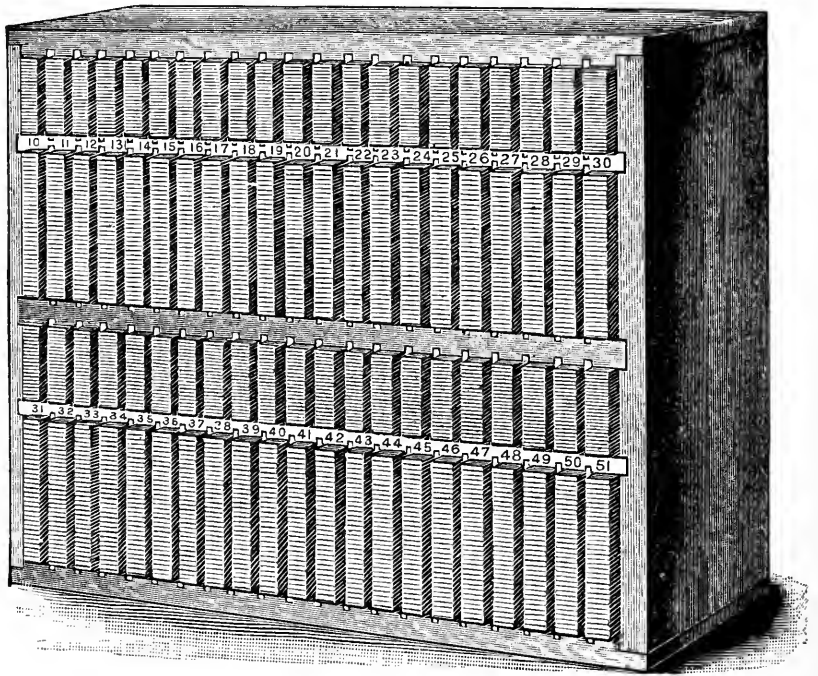

Reglet Case No. 4. 2100 pieces, \$8 00.

| Case. | No. of Pieces. | No. of Yards. | Lengths in Case. | Price. |
|-----------------|----------------|---------------|------------------|---------|
| No. 1 | 1800 | 300 | 10 to 60 ems. | \$ 8 00 |
| No. 2 | 2400 | 600 | 10 to 120 ems. | 14 00 |
| No. 3 | 4200 | 550 | 10 to 51 ems. | 15 00 |
| No. 4 | 2100 | 275 | 10 to 51 ems. | 8 00 |
| No. 5 | 6300 | 1500 | 10 to 150 ems. | 38 00 |
| No. 6 | 3150 | 750 | 10 to 150 ems. | 20 00 |

REGLET CUT TO LENGTHS.

Nonpareil or Pica. Tied in Bundles.

| | | | |
|-----------------------------------|--------|-----------------------------------|--------|
| 100 pieces, 10 ems long | \$0 15 | 100 pieces, 45 ems long | \$0 50 |
| 100 pieces, 15 ems long | 0 20 | 100 pieces, 50 ems long | 0 55 |
| 100 pieces, 20 ems long | 0 25 | 100 pieces, 55 ems long | 0 60 |
| 100 pieces, 25 ems long | 0 30 | 100 pieces, 60 ems long | 0 65 |
| 100 pieces, 30 ems long | 0 35 | 100 pieces, 65 ems long | 0 70 |
| 100 pieces, 35 ems long | 0 40 | 100 pieces, 70 ems long | 0 75 |
| 100 pieces, 40 ems long | 0 45 | | |

Other lengths at proportionate prices.

LABOR=SAVING FURNITURE, WITHOUT CASES.

| | |
|---|--------|
| Half font of 280 pieces, in a box | \$2 75 |
| Single font of 560 pieces, in a box | 5 00 |
| Double font of 1120 pieces, in a box | 10 00 |
| Mammoth font of 1530 pieces, in a box | 25 00 |

LABOR=SAVING FURNITURE.

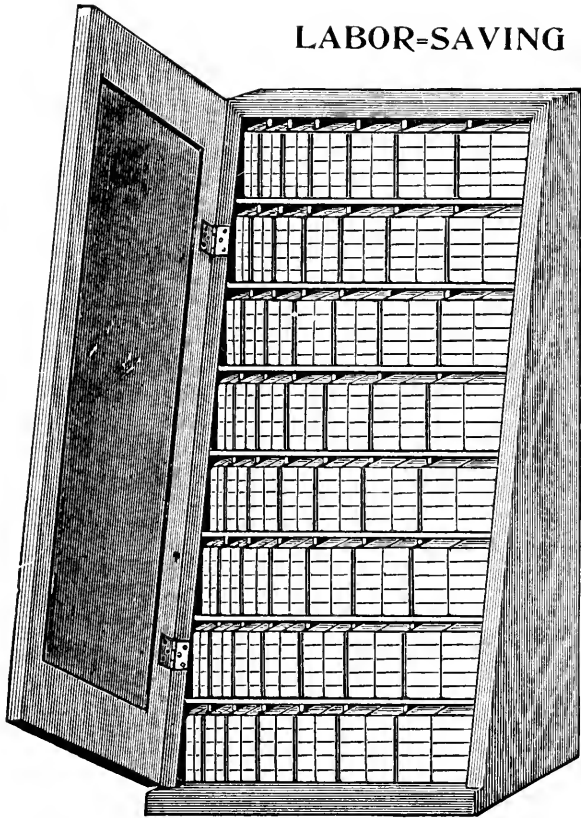

This Labor-Saving Furniture is thoroughly oiled, and cut to the point standard. Every piece has the size stamped on the end.

Cases are made *with* or *without* partitions. The usefulness of the font is doubled by having it in a case with partitions.

A single case contains 560 pieces, divided into 10 pieces, each 10, 15, 20, 25, 30, 40, 50 and 60 ems long by 2, 3, 4, 5, 6, 8 and 10 ems wide.

A half case contains half the number of pieces held in a single case.

THE No. 7 MAMMOTH CASE

is especially designed for large offices, and contains the following assortment of selected furniture, from 10 to 160 ems long: 270 pieces each 2-line, 3-line and 4-line furniture; 225 pieces each 5-line and 6-line furniture; 135 pieces each 8-line and 10-line furniture—assorted in 10, 15, 20, 25, 30, 40, 50, 60, 70, 80, 90, 100, 120, 140 and 160 ems lengths. There is a larger proportion of the narrower and most-used sizes than of the wide furniture.

- No. 1. Half case contains 280 pieces, with partitions . . . \$ 6 00
- No. 2. Half case contains 280 pieces, without partitions . . . 5 00
- No. 3. Single case contains 560 pieces, with partitions . . . 10 00
- No. 4. Single case contains 560 pieces, without partitions . . . 8 00
- No. 5. Double case contains 1120 pieces, with partitions . . . 18 00
- No. 6. Double case contains 1120 pieces, without partitions . . . 15 00
- No. 7. Mammoth case, designed for large offices, with partitions, no door (see description above) . . . 40 00

No. 3. Single Case, with Partitions and Door.

No. 7. Mammoth case, designed for large offices, with partitions, no door (see description above)

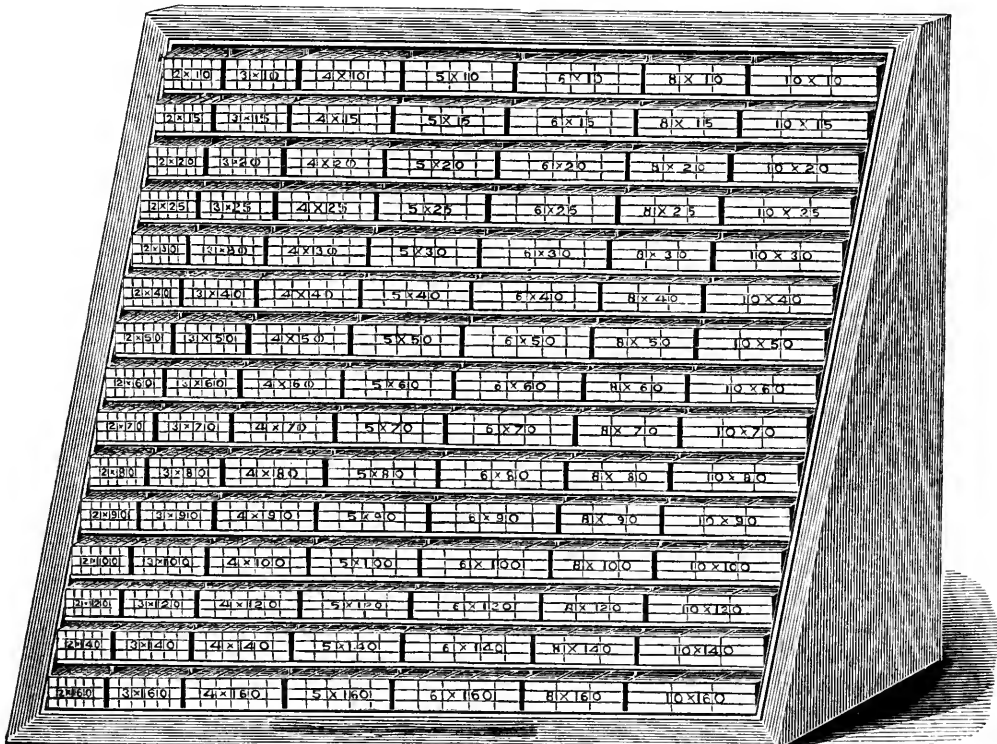

No. 7. Mammoth Labor-Saving Furniture Case.

LABOR-SAVING LEAD RACKS.

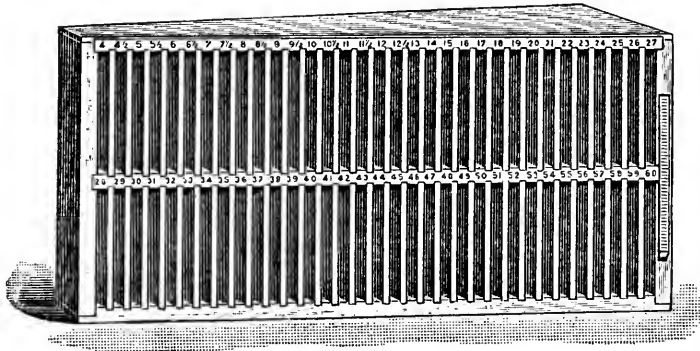

Two-tier Wisconsin Lead Rack ; 4 to 12½ by ems,
13 to 60 by ems.

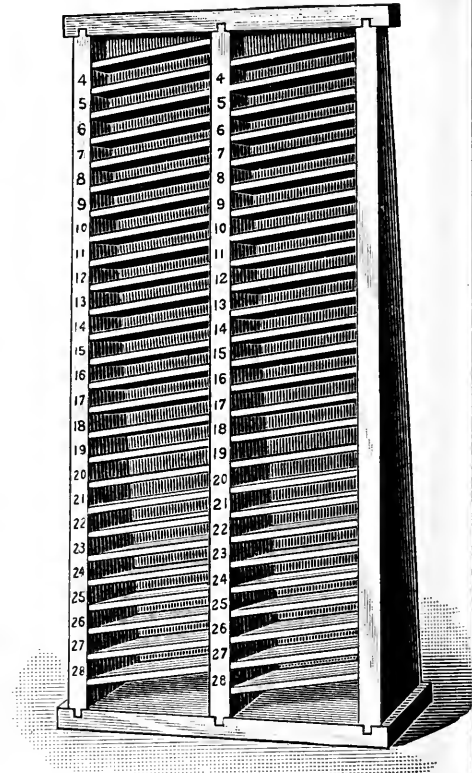

Eureka Lead Rack.

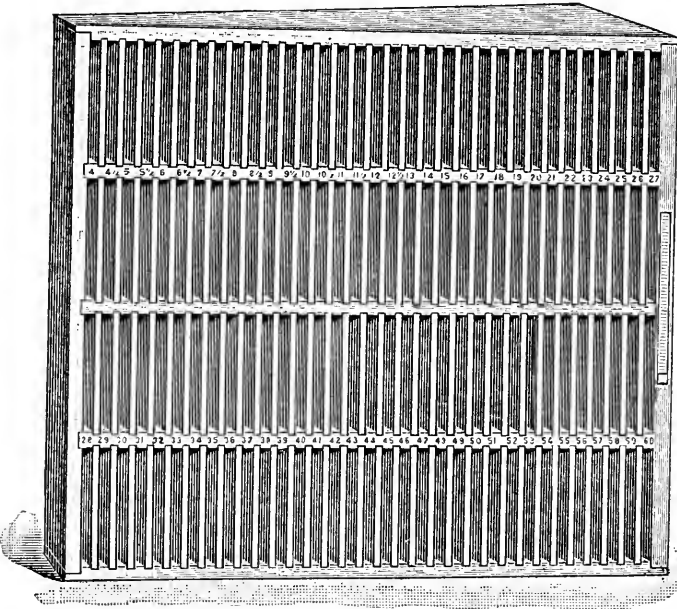

Four-tier Wisconsin Lead Rack ; 4 to 12½ by ems,
13 to 60 by ems twice.

PRICES.

Two-tier Wisconsin Lead Rack \$6 00

Takes leads from 4 to 12½ ems (varying by ems), and from 13 to 60 ems (varying by ems), the length being stamped over each compartment. Compartments are eight inches high. Will hold 750 pounds of leads and slugs.

Four-tier Wisconsin Lead Rack \$9 00

Has two compartments each for all sizes in the two-tier rack, and is similar in design and construction. Will hold 1500 pounds of leads and slugs.

Eureka Lead Rack \$2 50

Boston Lead Racks, set of four 5 40

- No. 1 holds 4 to 15 ems lengths 0 90
- No. 2 holds 16 to 30 ems lengths 1 20
- No. 3 holds 31 to 45 ems lengths 1 50
- No. 4 holds 46 to 60 ems lengths 1 80

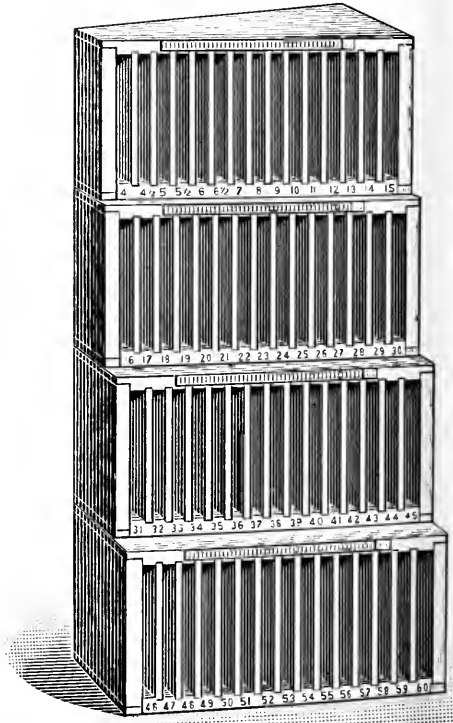

Boston Lead Racks.

MAKE-UP TABLES.

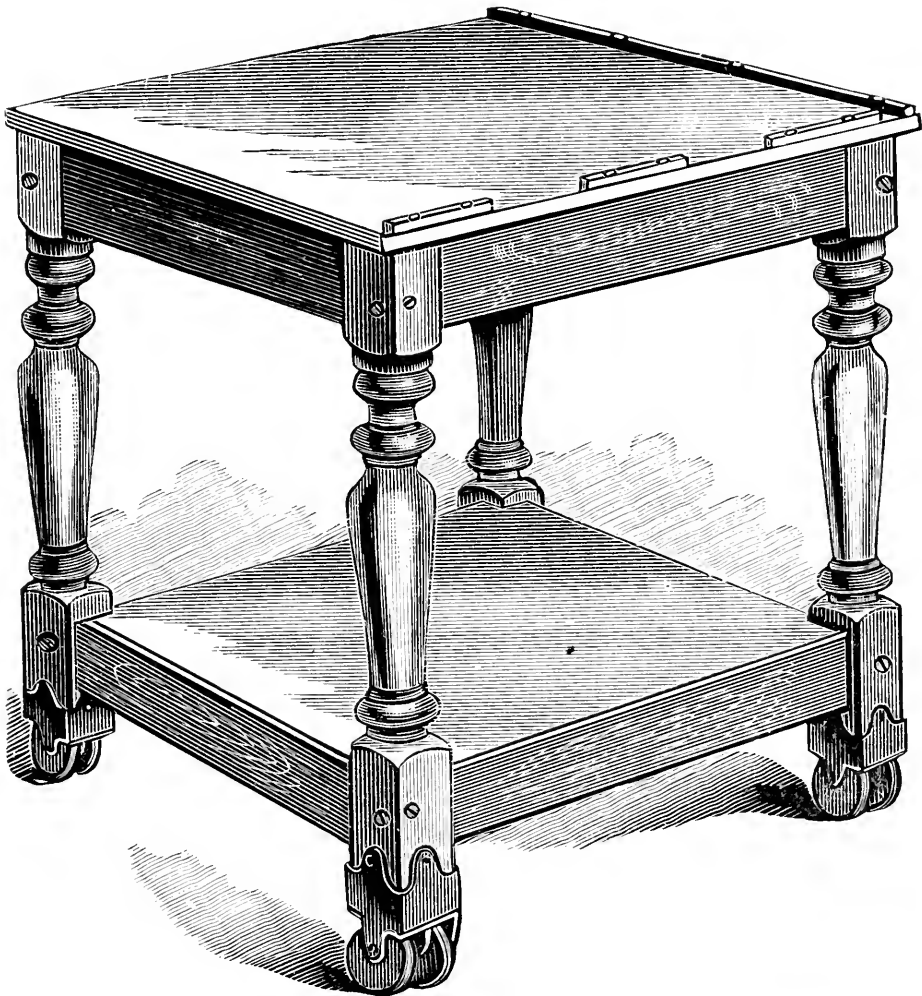

These tables are used for making-up and carrying forms either to the beating table or matrix-rolling machine (or elevator, if the stereotype room is not on the same floor with the composing room), and are very substantially built of hard wood with patent double-roller revolving casters. The iron top is either smoothed off or covered with brass—the latter being preferred by the leading newspaper offices.

| Size of Matter. | Price, Iron Top. | Price, Top Covered with Brass. |
|------------------------|------------------|--------------------------------|
| 15×20 inches | \$40 00 | \$50 00 |
| 18×24 inches | 50 00 | 60 00 |
| 21×28 inches | 55 00 | 65 00 |
| 24×32 inches | 65 00 | 75 00 |

IRON-TOP BEATING TABLES

FOR PAPER PROCESS.

| Size of Matter. | Price, Fixed Top. | Price, Elevating Top. | Size of Matter. | Price, Fixed Top. | Price, Elevating Top. |
|------------------------|-------------------|-----------------------|------------------------|-------------------|-----------------------|
| 15×20 inches | \$40 00 | \$75 00 | 21×28 inches | \$55 00 | \$105 00 |
| 18×24 inches | 50 00 | 95 00 | 24×32 inches | 65 00 | 125 00 |

IMPOSING TABLES AND MARBLE STONES.



Square-leg Imposing Table.

The imposing stone is an important piece of furniture in every printing office, and should be carefully selected with a view of getting the best the market affords. Our line is unsurpassed. The tables are made strong and serviceable, and fitted with the best hard marble tops and a strong coffin.

| | Price of Stone. | Square-leg Table and Stone. | Round-leg Table and Stone. |
|---|-----------------|-----------------------------|----------------------------|
| For 6-column paper, 2 pages 24×36 inches | \$ 6 00 | \$13 25 | \$16 00 |
| For 7-column paper, 2 pages 26×44 inches | 8 00 | 16 00 | 20 00 |
| For 8-column paper, 2 pages 28×50 inches | 10 00 | 19 00 | 24 00 |
| For 9-column paper, 2 pages 32×60 inches | 13 50 | 23 50 | 28 50 |
| For 7-column paper, 4 pages 26×76 inches | 13 75 | 24 50 | 35 00 |
| For 8-column paper, 4 pages 28×80 inches | 15 50 | 28 00 | 38 00 |
| For 9-column paper, 4 pages 30×90 inches | 18 75 | 33 25 | 43 75 |
| For 6-column quarto, 4 pages 36×60 inches | 15 00 | 27 00 | 32 00 |
| For 7-column quarto, 4 pages 48×60 inches | 20 00 | 35 00 | 40 50 |

COFFINS.—When coffins only are desired, they can be had in any size, at 75 cents per running foot the long way.

A "coffin" is a hard wood frame which serves as a bed for the stone, protects its edges, and affords a rest for galleys when used for sliding off matter.

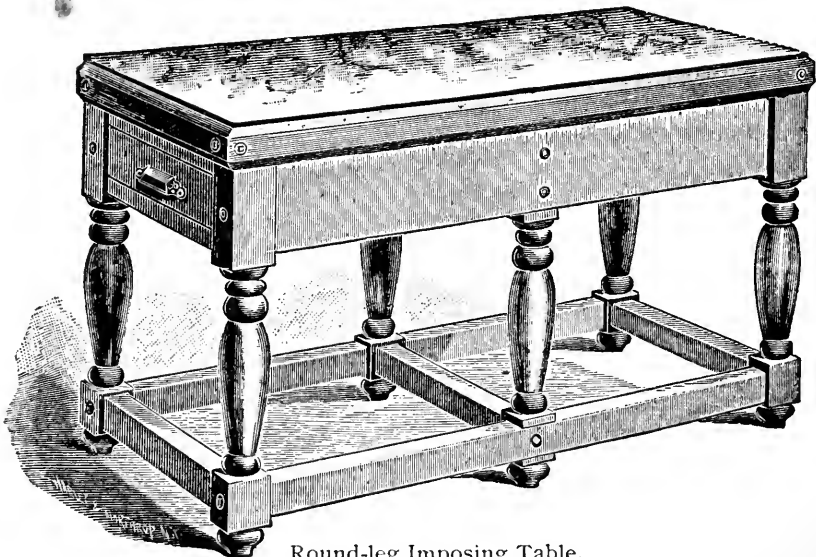

Round-leg Imposing Table.

IMPOSING TABLES WITH LETTER BOARDS.

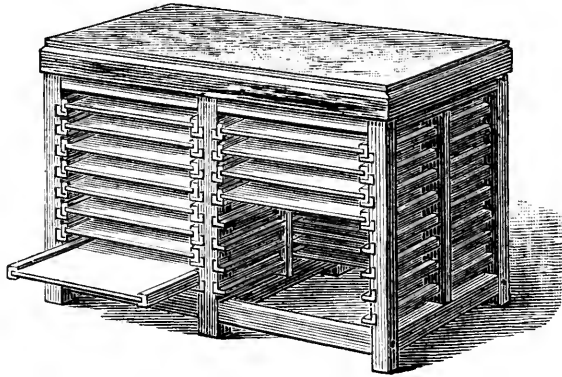

No. 9. With 36×60-inch Marble Top; has 32 Letter Boards, each 17½×26 inches inside.

No better disposition of the space underneath an imposing table can be made than to use it for letter boards. If the type is dead, it is shifted from the stone to the board without loss of time; if the matter is alive, it is handy for imposition.

These tables are made in the most substantial manner, of hard wood, and are strongly and firmly bolted together. The boards are made of hard wood, closed at sides and back, and are rabbeted in front to receive galley when sliding off type.

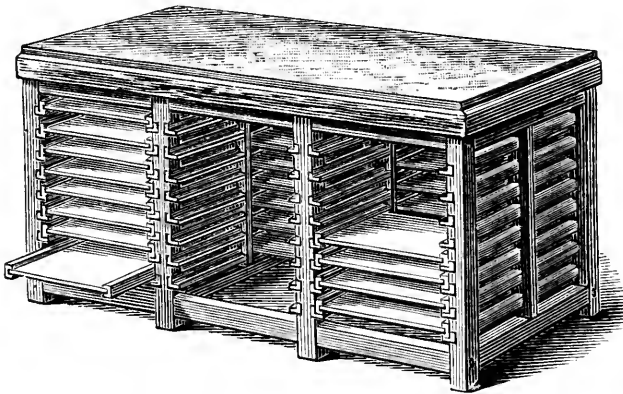

No. 10. With 40×80-inch Marble Top; has 48 Letter Boards, each 19½×22½ inches inside.

Prices with Hard Marble Stones.

| | Number of Boards. | Size of Stone. | Size of Boards. | Without Boards. | Boards each. | Complete with Boards. |
|------------------|-------------------|-----------------|-------------------|-------------------|------------------|-----------------------|
| No. 2 | 10 | 24×36 | 22 × 32 | | | \$40 00 |
| No. 3 | 10 | 32×48 | 30 × 44 | | | 60 00 |
| No. 9 | 32 | 36×60 | 17½×26 | \$42 50 | \$1 00 | 72 50 |
| No. 10 | 48 | 40×80 | 19½×22½ | 55 00 | 0 90 | 95 50 |

IRON IMPOSING SURFACES

Supplied any size to order 2½ cents per square inch, net.

MARBLE INK SLABS.

| | |
|------------------------|--------|
| 8×12 inches | \$1 25 |
| 12×18 inches | 2 00 |
| 18×24 inches | 3 75 |

STANDING GALLEYS.

Made to Order.

Buyers may have these made to any dimensions they desire, at prices proportionate to those quoted below for the sizes and styles commonly used.

The space underneath may be utilized in various ways. In place of the case racks, as shown in the cuts, galley shelves and racks or letter boards can be put in. In ordering Standing Galleys, or in sending for estimates of cost, it is necessary to be *explicit* as to measurements and other requirements.

The regular width of single columns is three inches; of double columns, six inches; but these may be varied. The column strips are made of the same material as ordered for the top.

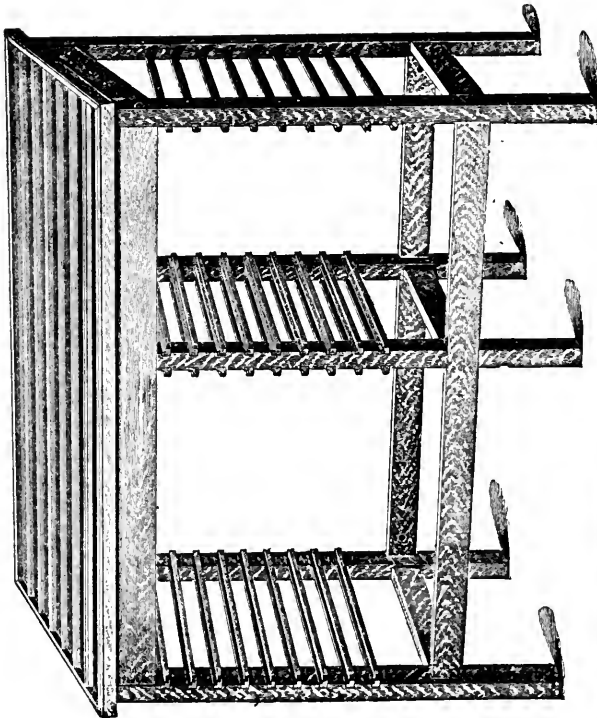

| No. | Length Over All. | Material Used on Top. | What the Racks Hold. | 5 Single Columns. Top 20 ins. wide. | 6 Single Columns. Top 23 1/2 ins. wide. | 7 Single Columns. Top 27 ins. wide. | 8 Single Columns. Top 30 1/2 ins. wide. | 9 Single Columns. Top 34 ins. wide. | 10 Single Columns. Top 37 1/2 ins. wide. |
|-----|------------------|-----------------------------------|---|-------------------------------------|---|-------------------------------------|---|-------------------------------------|--|
| 1 | 5 feet | Hard-wood Top, with wooden strips | 8 each full and two-third cases | \$14 75 | \$15 25 | \$15 75 | \$16 25 | \$16 75 | \$17 25 |
| 1A | 5 feet | Zinc Lined | | 19 75 | 21 00 | 22 50 | 24 00 | 25 75 | 27 50 |
| 1B | 5 feet | Brass Lined | 20 00 | 29 00 | 32 00 | 35 00 | 38 00 | 41 00 | 44 00 |
| 2 | 6 feet | Hard-wood Top, with wooden strips | 8 each full and two-third cases and 14 galley racks | 16 00 | 16 55 | 17 10 | 17 65 | 18 20 | 18 75 |
| 2A | 6 feet | Zinc Lined | | 22 75 | 24 00 | 25 50 | 27 00 | 28 75 | 30 50 |
| 2B | 6 feet | Brass Lined | 31 00 | 34 50 | 38 00 | 41 50 | 45 00 | 48 50 | 52 00 |
| 3 | 7 feet | Hard-wood Top, with wooden strips | 16 full-size cases | 18 80 | 19 45 | 20 10 | 20 75 | 21 40 | 22 05 |
| 3A | 7 feet | Zinc Lined | | 26 75 | 27 50 | 29 50 | 31 00 | 32 75 | 34 50 |
| 3B | 7 feet | Brass Lined | 35 50 | 39 50 | 43 50 | 47 50 | 51 50 | 55 50 | 59 50 |
| 4 | 8 feet | Hard-wood Top, with wooden strips | 16 full-size cases and 14 galley racks | 23 50 | 24 25 | 25 00 | 25 75 | 26 50 | 27 25 |
| 4A | 8 feet | Zinc Lined | | 31 75 | 32 50 | 34 50 | 36 00 | 37 75 | 39 50 |
| 4B | 8 feet | Brass Lined | 42 00 | 46 50 | 51 00 | 55 50 | 60 00 | 64 50 | 69 00 |
| 5 | 10 feet | Hard-wood Top, with wooden strips | 24 full-size cases | 25 25 | 26 25 | 27 25 | 28 25 | 29 25 | 30 25 |
| 5A | 10 feet | Zinc Lined | | 35 75 | 38 50 | 40 50 | 42 00 | 43 75 | 45 50 |
| 5B | 10 feet | Brass Lined | 49 50 | 54 75 | 60 00 | 65 25 | 70 50 | 75 75 | |
| 6 | 12 feet | Hard-wood Top, with wooden strips | 32 full-size cases | 29 50 | 30 05 | 31 80 | 32 95 | 34 10 | 35 25 |
| 6A | 12 feet | Zinc Lined | | 40 75 | 43 50 | 45 75 | 48 00 | 50 75 | 53 50 |
| 6B | 12 feet | Brass Lined | 57 75 | 64 50 | 71 25 | 78 00 | 84 75 | 91 50 | |

STANDING GALLEY WITH LETTER BOARDS.

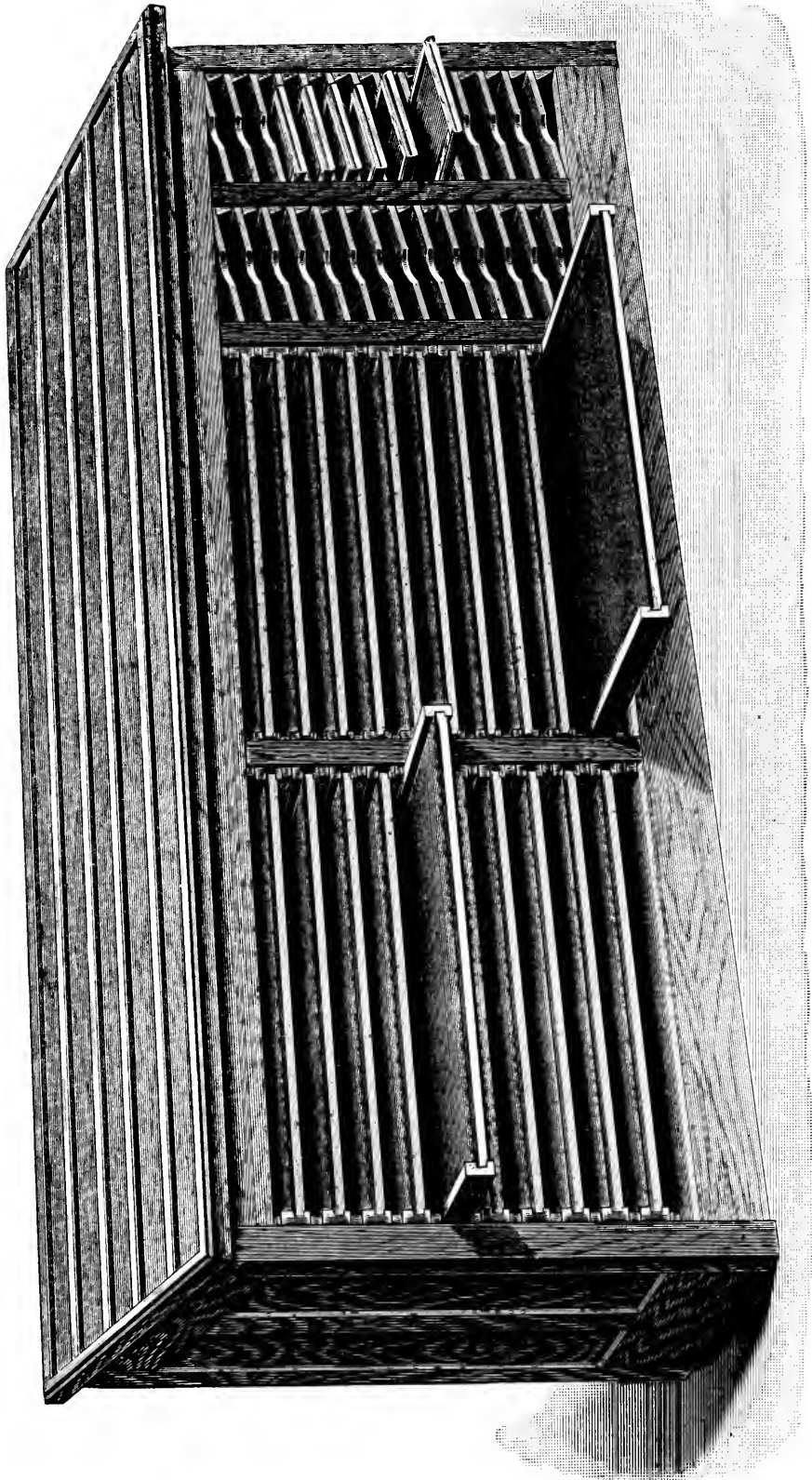

Contains 20 hard-wood letter boards, size of each $24 \times 30\frac{1}{2}$ inches inside, and racks for 26 triple-column galleys; or, if galley racks are not needed, 10 letter boards, each 24×21 inches inside, will be furnished instead at the same price. The brass-top style is covered with a single sheet of finest hard-rolled brass, and all division strips are lined with brass. Length, 8 feet; depth, 27 inches. Height in front, 3 feet; at back, 3 feet 10 inches.

No. 10, unlined, wood top \$60 00 | No. 11, zinc-lined top \$80 00 | No. 12, brass-lined top \$90 00

WROUGHT IRON CASE STANDS.

Made of Tubular Iron, with Strengthened and Bolted Joints. The Best Made of this Class of Stand.

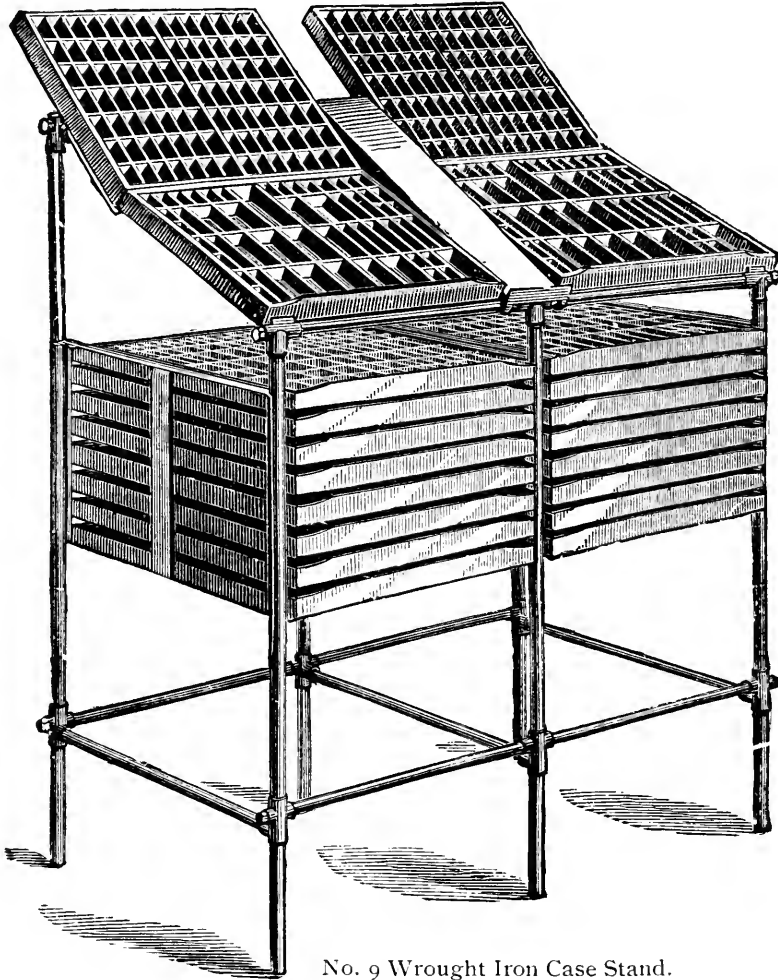

No. 9 Wrought Iron Case Stand.

| | | |
|---------|---|---------|
| No. 2. | Single, with racks for 8 full-size cases | \$12 00 |
| No. 3. | Single, with racks for 8 full-size cases and galley rest | 13 00 |
| No. 5. | Double, with racks for 8 full-size cases | 15 00 |
| No. 6. | Double, with racks for 8 full-size cases and galley rest | 18 00 |
| No. 7. | Double, with racks for 8 full-size cases, galley rest, and 16 galley racks | 25 00 |
| No. 8. | Double, with racks for 8 full-size and 8 two-third cases | 19 00 |
| No. 9. | Double, with racks for 16 full-size cases and galley rest (see cut) | 20 50 |
| No. 10. | Double, with racks for 8 full-size and 8 two-third cases, galley rest and 16 galley racks | 30 00 |

PERFECTION WROUGHT IRON STANDS.

The Quadruple Stand has novel features. The cases on top project eight inches from the rack, giving the compositor plenty of knee room. The galleys between top cases are six inches wide, and divided into convenient spaces.

| | |
|--|---------|
| Perfection Quadruple Stand, with racks for 24 cases | \$30 00 |
| Perfection Quadruple Stand, with racks for 48 cases | 35 00 |
| Perfection Double News Stand, with racks for 12 cases | 16 00 |
| Perfection Double Book Stand, with racks for 24 cases | 20 00 |
| Single News Stand, with racks for 8 cases | 10 00 |
| Double Job Stand, with racks for 12 full-size and 12 two-third cases | 20 00 |
| Double Stand (racks back to back), with racks for 12 cases | 16 00 |

Made for full-size, three-quarter or Rooker cases at the same prices.

WROUGHT IRON HORIZONTAL STANDING GALLEY.

With All-Brass Top.

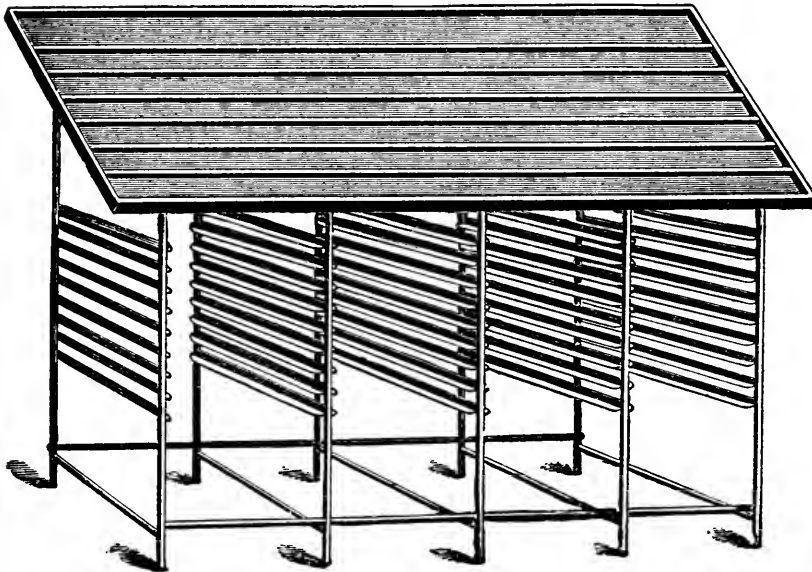

The Wrought Iron Standing Galleys, with columns running horizontally (see cut), have iron racks and all-brass tops. The brass strips screwed on top are L-shaped, making the partitions only a little wider than column width, but leaving enough room for the fingers to lift the type, thus reducing the width of the top, making it more convenient to reach the upper rows. The columns are made to any desired length and width.

The cut on this page is an illustration of the No. 6 size, which is 12 feet long, with iron racks for 32 full-size cases.

| No. | Length of Rack. | What the Racks Hold. | 5 Single Columns. | 6 Single Columns. | 7 Single Columns. | 8 Single Columns. | 9 Single Columns. | 10 Single Columns. |
|-----|-----------------|---|-------------------|-------------------|-------------------|-------------------|-------------------|--------------------|
| 1 | 5 feet | 8 two-third and 8 full-size cases . . | \$54 00 | \$58 00 | \$62 00 | \$66 00 | \$70 00 | \$74 00 |
| 2 | 6 feet | 8 two-third and 8 full-size cases and 16 galley racks | 70 00 | 75 00 | 80 00 | 85 00 | 90 00 | 95 00 |
| 3 | 7 feet | 16 full-size cases | 65 00 | 71 00 | 77 00 | 83 00 | 89 00 | 95 00 |
| 4 | 8 feet | 16 full-size cases and 16 galley racks | 80 00 | 86 00 | 92 00 | 98 00 | 104 00 | 110 00 |
| 5 | 10 feet | 24 full-size cases | 85 00 | 92 00 | 99 00 | 106 00 | 113 00 | 120 00 |
| 6 | 12 feet | 32 full-size cases | 95 00 | 104 00 | 113 00 | 122 00 | 131 00 | 140 00 |

WROUGHT IRON LONGITUDINAL STANDING GALLEY.

With All-Brass Top.

Made entirely of brass and wrought iron. The top is covered with sheet brass, and screwed on the hard-wood top from underneath.

Standing galleys with columns running longitudinally are designed for dead matter, and are almost indispensable. Uniform distribution is guaranteed, as the compositor is compelled to take the type from the top, and gets it into the cases regularly; consequently the type gets an even wear. The front is provided with a channel or gutter for the water used in wetting the type to run off into a receptacle. Any size made to order.

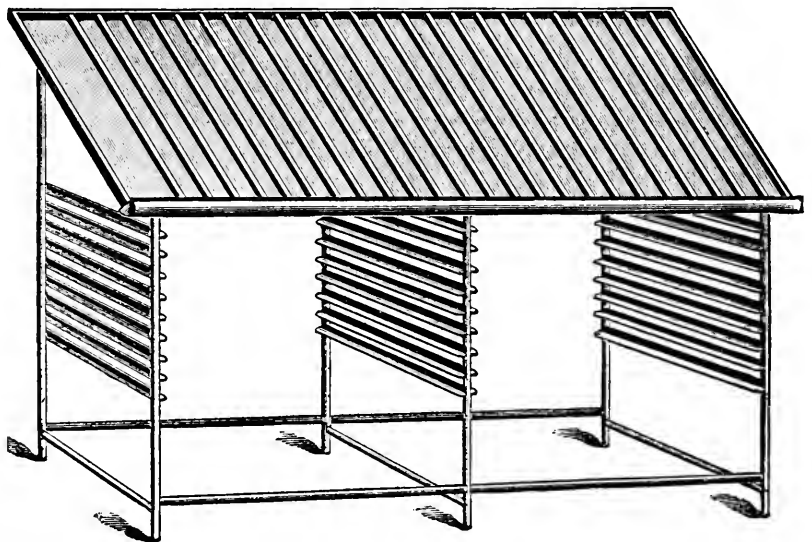

Wrought Iron Standing Galley, with All-Brass Top. This illustrates one 7 feet long and 26 inches wide.

Price, per single column, 26 inches deep, in banks not less than 5 feet long \$3 50

MOVABLE DRYING RACKS.

The frames of both these racks are of hard wood, bolted together, and mounted on strong casters, so that they can be easily moved when loaded. The shelves of the Chicago Rack are framed all around with hard wood, while those of the New York Rack are framed on ends only.

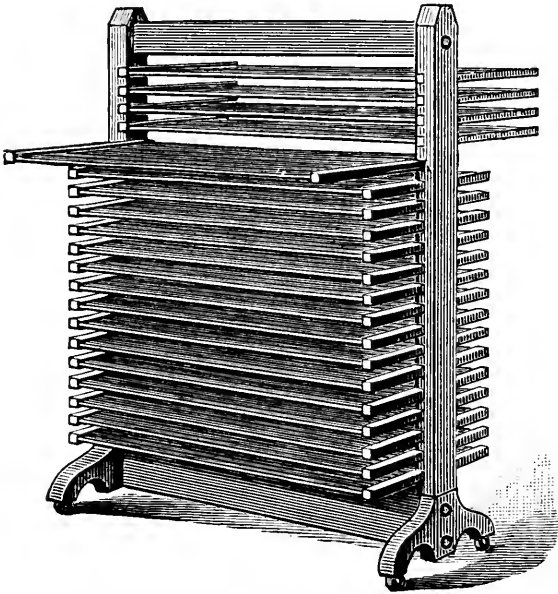

No. 1 New York Drying Rack.

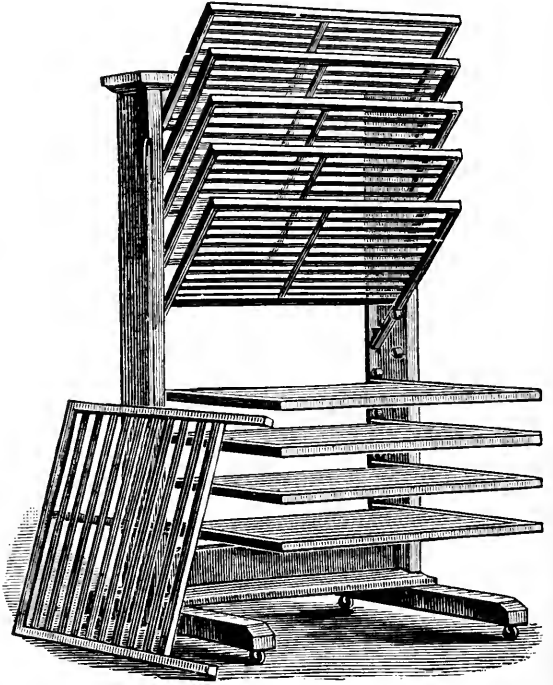

No. 6 Chicago Drying Rack.

NEW YORK DRYING RACKS.

- | | |
|---|---|
| No. 1. 20 shelves, each 24×36 in. . \$19 00 | No. 3. 20 shelves, each 28×42 in. . \$23 00 |
| No. 2. 30 shelves, each 24×36 in. . 23 00 | No. 4. 30 shelves, each 28×42 in. . 32 00 |

The No. 1 rack (the cheapest) gives a drying area of one hundred and twenty square feet, while actually using only six square feet of your costly floor space.

CHICAGO DRYING RACKS.

- | | |
|---|--|
| No. 5. 12 shelves, each 2×2 feet . . \$19 00 | No. 6. 10 shelves, each 2×3 feet . . \$22 00 |
| No. 7. 10 shelves, each 2½×4 feet . . \$26 00 | |

This rack is the most substantial movable drying rack made. Although it has fewer shelves than a New York, the extra space between the shelves is a distinct advantage, as on small jobs the sheets can be handled without moving the shelf on which they are placed. When not in use the shelves may be put out of the way, as illustrated in cut.

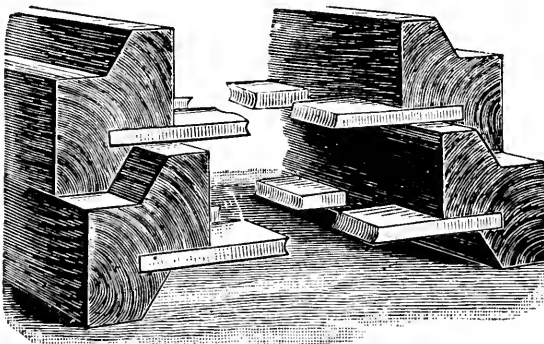

Figure 2. End View of Interlocking Device.

BEST RACKS FOR LARGE EDITIONS.

The Kærner Drying Racks, described on opposite page, have saved large firms thousands of dollars per year by enabling them to utilize their floor space to the utmost extent, making slip-sheeting unnecessary on very many jobs and preventing wastage by handling sheets. The interlocking device and method of inserting the slats into the sides is very plainly illustrated in Figure 2. No large establishment can afford to use wall-racks now that these effective racks, used in connection with trucks, will save their cost every month in the year.

KÖERNER'S PATENT INTERLOCKING DRYING RACKS.

(United States Patent, No. 392,735; Canadian Patent, No. 28,739.)

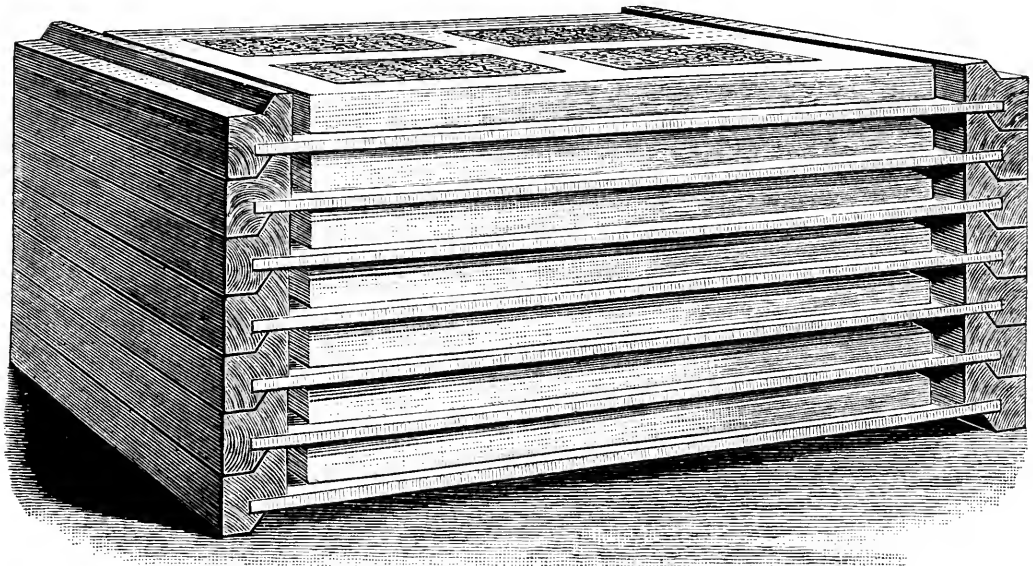

Fig. 2. Interlocking Racks Stacked with Paper, straight and rigid.
(See illustration of Interlocking Device on preceding page.)

These racks are for establishments which work on long runs, for color work, and for lithographers. They are used on *Puck* and *Truth*, and the American Lithographing Company has over 25,000 of them in its various establishments in New York City alone.

With these racks sheets are taken direct from the fly of the press, and may be stacked ceiling-high in a perfectly straight and rigid pile, which cannot be knocked over by accident, and with no more weight on the bottom than on the top sheets. This pile is a most effective drying room, occupying only the floor space of one rack, and from the time the sheets are fed into the machine until ready for shipment they need not be handled. The interlocking device, which makes the pile straight and rigid, is shown in Figure 2. Each rack is firmly locked on its neighbor, but each slides with ease on the rack immediately below it. They save handling, all the time of that operation, and the consequent waste of paper through offset, smearing, finger-marks and tearing. In many cases these racks save expensive slip-sheeting. They circumvent electricity by receiving the sheet direct from the fly. They insure evenness of temperature, and thereby assist in getting a perfect register on lithographic work. They save seventy-five per cent. of floor space over any other method of drying sheets, and from one to two per cent. of paper, and a vast amount of time. A further saving of time may be effected by placing the racks as they come from the fly-board on a printer's truck, made to take these racks (see "Printers Truck"). A pile of racks can be moved quicker, safer and easier on the truck than a single armful can be moved by hand. The racks have hard-wood sides with wide soft-wood slats, and are very strongly put together.

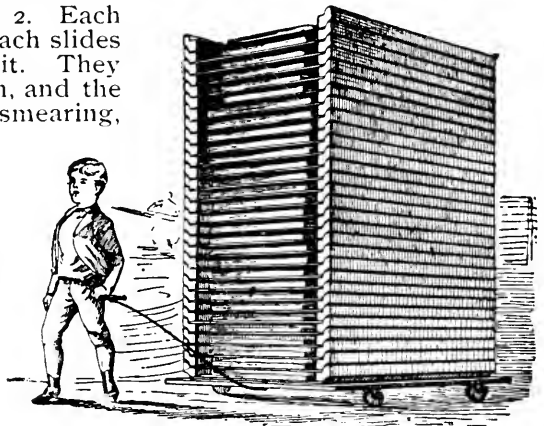
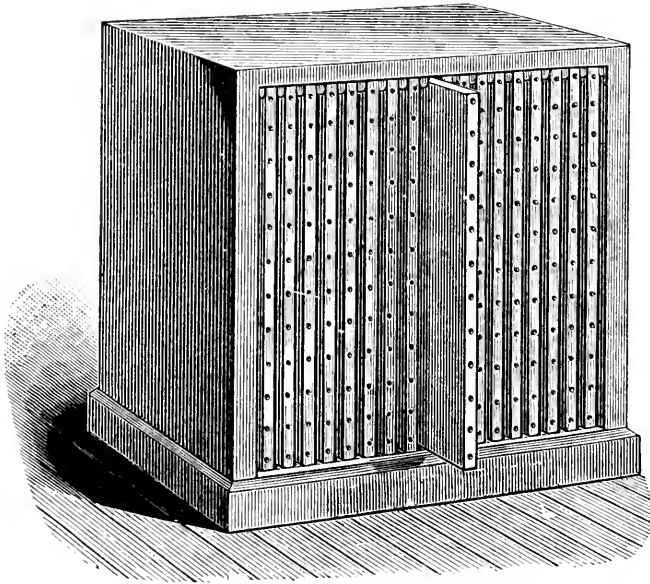

Fig. 1. Köerner's Racks on Printer's Truck.

NET PRICES.—Special Quotations Made on Car-load Lots.

These racks are made to order, and sizes will be varied to suit purchasers, at prices approximate to those quoted here :

| | |
|---|--|
| 38×52 in. inside and under \$0 65 | 15 ×21 in. inside and under . . . \$0 35 |
| 32×48 in. inside and under 0 60 | 13 ×19 in. inside and under . . . 0 30 |
| 24×36 in. inside and under 0 50 | 11 ×17 in. inside and under . . . 0 25 |
| 18×25 in. inside and under 0 40 | 8¾×13 in. inside and under . . . 0 20 |



**BRASS-BOUND
PRESS
BOARDS.**

Made of seasoned, kiln-dried cherry, bound with hard brass, with folded corners.

16×24 inches, each \$2 75
Case to hold 18 boards 5 00

Other sizes made to order. Special quotations given on large orders.

BOOKBINDERS' PRESS BOARDS.

Made from seasoned cherry with cleated ends, and all guaranteed first-class, at the following prices, each :

| | | |
|---------------------------|---------------------------|---------------------------|
| 6×10½ inches . . . \$0 20 | 12×16 inches . . . \$0 60 | 22×28 inches . . . \$1 30 |
| 8×10½ inches . . . 0 25 | 12×18 inches . . . 0 70 | 24×30 inches . . . 1 35 |
| 8×12 inches . . . 0 30 | 13×20 inches . . . 0 75 | 24×32 inches . . . 1 45 |
| 10×13 inches . . . 0 35 | 15×20 inches . . . 0 80 | 26×40 inches . . . 2 80 |
| 11×14 inches . . . 0 45 | 16×24 inches . . . 0 95 | 30×36 inches . . . 3 25 |
| 10×16 inches . . . 0 55 | 20×24 inches . . . 1 05 | 36×44 inches . . . 4 50 |

Other sizes made to order at proportionate prices. Special quotations given on large orders.

**END-WOOD
CUTTING
BOARDS.**

Made of end-wood, kiln-dried maple, two inches thick, any size desired. Each piece is grooved on all sides, and spliced and glued to the adjoining pieces, the result being the most durable and perfect cutting board which can be made.

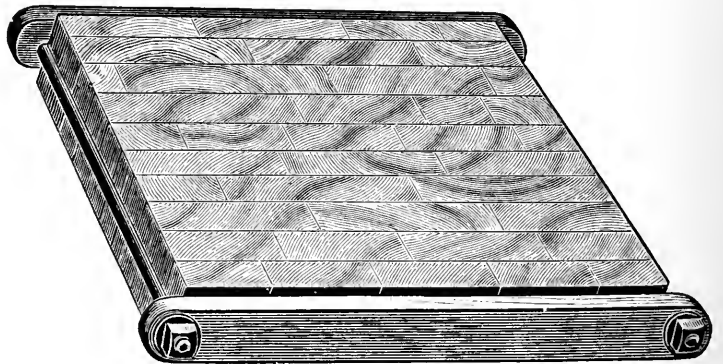

Per square inch, face measure, for plain end-wood boards, without iron rods . . \$0 01½
Per square inch, face measure, for reinforced boards, with iron rods and binding strips 0 02

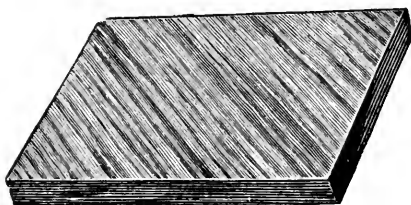

DIAGONAL GRAIN CUTTING BOARDS.

Made of kiln-dried maple. The diagonal grain blocks are the best procurable for this purpose.

8×12 Board, diagonal grain, per pair \$1 75
8×12 Board, straight grain, per pair 1 20
Larger sizes, straight grain, per square foot . . 0 90
Larger sizes, diagonal grain, per square foot . 1 25

CUTTING STICKS.

| | ½ Inch Square. | ¾ to 1½ Inch Square. | Round for Acme | Octagon for Leader. |
|--|----------------|----------------------|----------------|---------------------|
| 30-inch and under, per dozen | \$0 75 | \$1 50 | \$2 50 | \$2 00 |
| 34-inch and under, per dozen | 0 80 | 1 60 | 2 50 | 2 15 |
| 38-inch and under, per dozen | 0 85 | 1 70 | 2 75 | 2 25 |
| 44-inch and under, per dozen | 0 95 | 1 85 | 3 00 | 2 50 |
| 48-inch and under, per dozen | 1 00 | 1 95 | 3 50 | 2 75 |
| 54-inch and under, per dozen | 1 00 | 2 10 | 4 00 | 3 00 |

CUTTING STRIPS.

For Hamilton's Patent Cutting Stick, described below.

| | |
|---|--------|
| Under 38 inches, per dozen, net | \$0 25 |
| 38 inches and not exceeding 54 inches, per dozen, net | 0 40 |
| 55 inches and longer, per dozen, net | 0 50 |

HAMILTON PATENT CUTTING STICK

Consists of a main body piece (A), made to fit the groove of your paper cutter. The body piece has a groove or recess in it, which holds a small strip (B) one-quarter of an inch square. This removable strip is the cutting surface, and is held in place by a steel clamp (C), which is drawn up by the bolts (D). The cutting strips, being square, can be used on four sides, thus giving the same amount of service as the large-size sticks heretofore used.

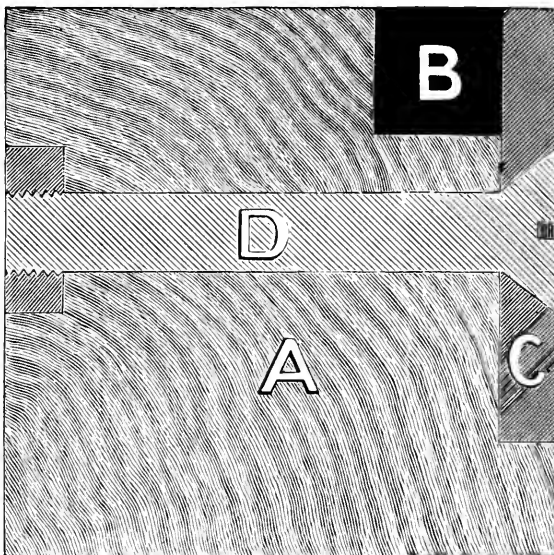

SEE THAT B?

- A** is the body piece made to fit groove in cutter.
- B** is the cutting strip on which knife strikes. It is one-fourth inch square, and is just as effective as if it was one and one-quarter inch square, also cheaper, and always fits.
- C** is the steel clamp which holds the cutting strip and prevents warping.
- D** is the screw which grips the clamp to the body piece.

ADVANTAGES.

1. The steel strip or clamp (C), running the extreme length of the main body piece, and firmly screwed thereto, effectively prevents springing and warping, which cannot be prevented on ordinary cutting sticks.
2. There is no wear on the body piece, and as it is fitted exactly to the groove of your cutter your troubles from ill-fitting sticks (necessitating packing, etc.) cease.
3. The cutting strips are all made to a uniform standard and are interchangeable, and thus there is an absolute certainty of them fitting.

HOW TO ORDER.

1. Give size square the main body piece is to be. Be particular on this point, and see that groove in cutter is accurately measured. 2. Give length of stick. 3. State how far from *front* edge of stick the knife strikes. 4. State whether knife cuts from right to left or left to right. In ordering cutting strips give the exact length required. All strips are cut to a standard uniform gauge, and are sure to fit.

| | |
|---|--------|
| Main body piece, under 38 inches long, net | \$5 00 |
| Main body piece, 38 inches to 54 inches long, net | 6 00 |
| Main body piece, 55 inches long and over, net | 7 00 |
| Cutting strips, under 38 inches long, per dozen, net | 0 25 |
| Cutting strips, 38 inches to 54 inches long, per dozen, net | 0 40 |
| Cutting strips, 55 inches and longer, per dozen, net | 0 50 |

SOLID-FACE TINT BLOCKS.

Most useful for the rapid setting up of tint forms. These blocks have a perfect, smooth surface, and print solidly.

| | | | |
|----------------------------------|--------|-----------------------------------|--------|
| 1 Pica wide, per foot | \$0 10 | 10 Picas wide, per foot | \$0 48 |
| 2 Picas wide, per foot | 0 12 | 12 Picas wide, per foot | 0 50 |
| 3 Picas wide, per foot | 0 15 | 15 Picas wide, per foot | 0 66 |
| 4 Picas wide, per foot | 0 20 | 18 Picas wide, per foot | 0 75 |
| 5 Picas wide, per foot | 0 22 | 20 Picas wide, per foot | 0 80 |
| 6 Picas wide, per foot | 0 24 | 24 Picas wide, per foot | 0 85 |
| 8 Picas wide, per foot | 0 36 | | |

Prices are net.

Larger pieces squared up, any size desired, at 1 cent per square inch.

LABOR-SAVING TINT BLOCKS.

These consist of strips of engravers' maple, with polished face, cut to even Picas and Nonpareils in width. A font consists of two pieces each 1, 1½, 2, 2½, 3, 3½, 4, 5, 6 and 8 ems Pica wide, all eight inches long. All the printer has to do to make a tint is to set his panel to even Picas, select a tint strip of same width, and cut it the desired length.

Price, per font, net \$1 00

MAPLE BLOCKS.

The following are standard sizes, and are kept in stock at factory. Other sizes made to order for 1½ cents per square inch. Minimum charge, 25 cents. Prices are net.

| | | | |
|----------------------------|--------|--------------------------|--------|
| 10 × 10 inches | \$1 00 | 15 × 15 inches | \$2 25 |
| 10 × 12 inches | 1 20 | 16 × 18 inches | 2 88 |
| 12 × 12 inches | 1 44 | 12 × 24 inches | 2 88 |
| 12½ × 12½ inches | 1 57 | 18 × 18 inches | 3 24 |
| 14 × 14 inches | 1 96 | 15 × 30 inches | 4 50 |

WOOD CIRCLES.

Made any size, mortised, with square or round bodies, as preferred. Prices are net.

| | |
|--|--------|
| 1- to 2-inch diameter, inside, each | \$0 40 |
| 2- to 4-inch diameter, inside, each | 0 75 |
| 4- to 6-inch diameter, inside, each | 1 00 |
| 6- to 8-inch diameter, inside, each | 1 25 |
| 8- to 10-inch diameter, inside, each | 1 75 |



HAMILTON NEWSPAPER FILE.

Made of cherry, finished in oil, with brass fastenings and polished steel thumb-screws. The method of opening and closing this file is novel and simple. The clasp end of file has a flat-headed thumb-screw (see cut), which is passed through a slot, and by giving the screw a quarter turn the file is securely locked. When the head is turned parallel with the file it opens instantly.

Price, each \$1 25

The following sizes are made:

| | |
|----------------------------|----------------------------|
| To hold sheet 20 in. long. | To hold sheet 28 in. long. |
| To hold sheet 22 in. long. | To hold sheet 30 in. long. |
| To hold sheet 24 in. long. | To hold sheet 34 in. long. |
| To hold sheet 26 in. long. | Other sizes to order. |

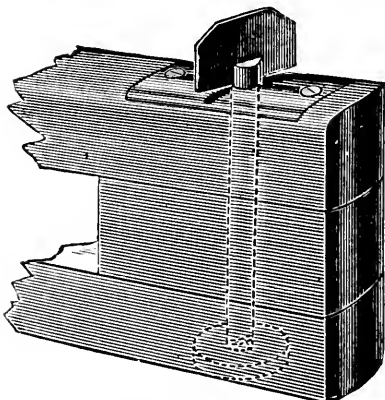

Fastening, closed.

THE "WELLS" LONG WOOD QUOINS.

These new quoins with their long bearing surface will increase the use of wooden quoins to a still greater extent. About the only advantage the metal quoin has over a wooden one is the long bearing. In using these quoins a perfect lock-up is secured, for the quoins are so long that a great pressure is secured without severe driving.

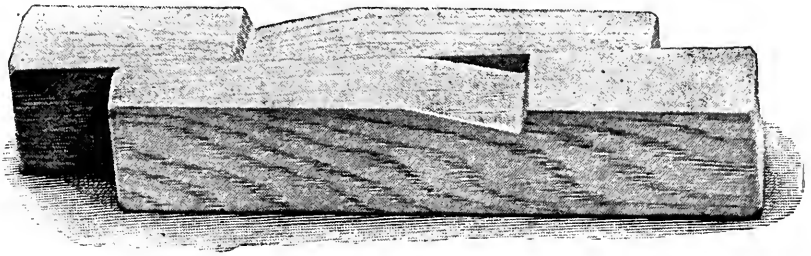

There is only one quoin, and any two quoins make a pair. They are beveled on one side only. No time is lost in looking for rights and lefts, and this is the secret of their success.

Straight furniture can be used and no side sticks are required. Every practical printer will appreciate this great advantage.

These quoins are improved by a top notch, which greatly assists in unlocking the forms. They are made in four sizes, all working in pairs with straight furniture, or they can be used singly with side sticks. Printers will recognize the superior advantages of this improved wooden quoin. They are put up in neat paper boxes, properly labeled, each box holding 100 quoins.

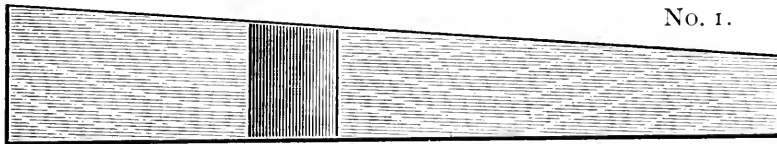

No. 1.



No. 2.

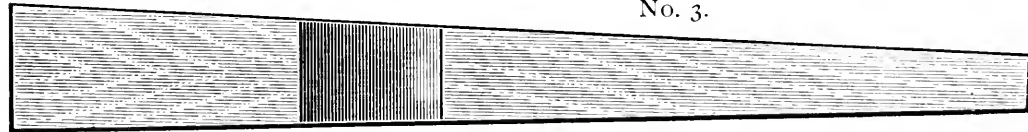

No. 3.

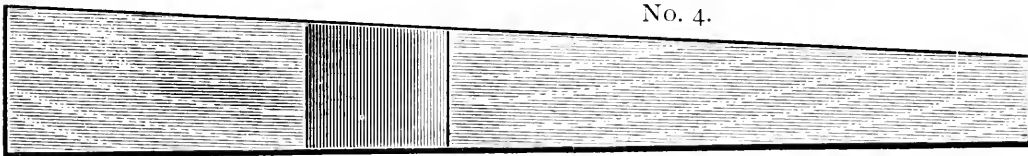

No. 4.

The above cuts show the top face of the Wells long wood quoins in their exact size. Beveled one way only.

LIST PRICES.

| | Hickory. | Boxwood. |
|------------------------------------|----------|----------|
| No. 1. Box of 100 quoins | \$0 75 | \$1 10 |
| No. 2. Box of 100 quoins | 0 75 | 1 10 |
| No. 3. Box of 100 quoins | 1 10 | 1 75 |
| No. 4. Box of 100 quoins | 1 10 | 1 75 |

WOODEN QUOINS.

| | Boxes of 100. | Burlap Bags of 500. | Burlap Bags of 1000. |
|--|---------------|---------------------|----------------------|
| Hickory | \$0 40 | \$1 80 | \$3 50 |
| Boxwood | 0 60 | 2 70 | 5 25 |
| Hickory, in barrels, containing about 7000, per 1000 | | | 3 25 |
| Boxwood, in barrels, containing about 7000, per 1000 | | | 5 00 |

PRINTERS' MACHINERY.

CHANDLER & PRICE GORDON PRESS.

A most popular press, and over 10,000 are in use. They are built to withstand both use and abuse. Side arms and shaft are made of forged steel, without seam or weld. Cam rollers are made of hardened tool steel. Impression throw-off is positive and easy to operate. The grippers are depressible, and cannot get under the rollers. Chase clamp is safe and instantaneous.

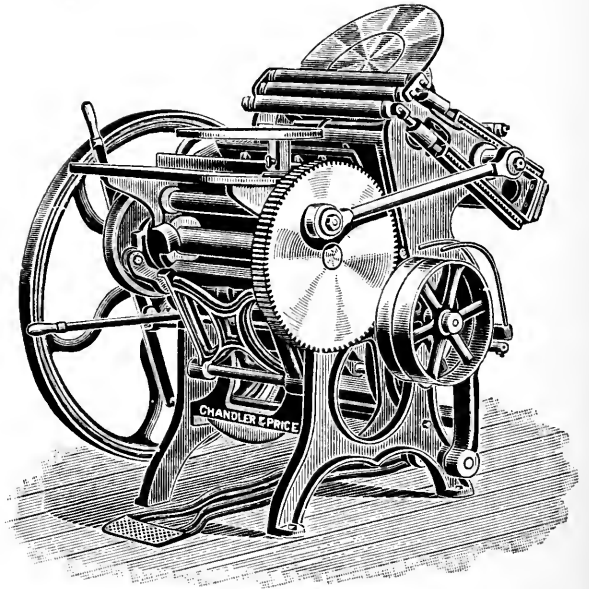

| | | |
|---|--|----------|
| Eighth Medium, | 7 × 11 inches inside chase | \$150 00 |
| Eighth Medium, | 8 × 12 inches inside chase | 165 00 |
| Quarto Medium, | 10 × 15 inches inside chase | 250 00 |
| Half Medium, | 12 × 18 inches inside chase | 300 00 |
| Large Half Medium, | 14 × 20 inches inside chase | 400 00 |
| Half Super-Royal, | 14½ × 22 inches inside chase | 450 00 |
| Steam Fixtures, all sizes | | 15 00 |
| Buckeye Fountain | | 10 00 |
| Chandler & Price Fountain | | 20 00 |
| American Counter (see page 1003), with attachments for any size press | | 12 00 |

WRITE FOR NET PRICES.

With each press there are three chases, one brayer, two wrenches, one set of cast rollers and one extra set of stocks. If desired, will send two extra chases or roller mould instead of covering one set of stocks with composition. No charge for boxing and shipping.

Shipping weights: 7×11, 1000 lbs.; 8×12, 1200 lbs.; 10×15, 1800 lbs.; 12×18, 2500 lbs.; 14×20, 3000 lbs.; 14½×22, 3100 lbs.

For prices of extra chases, see page 1085.

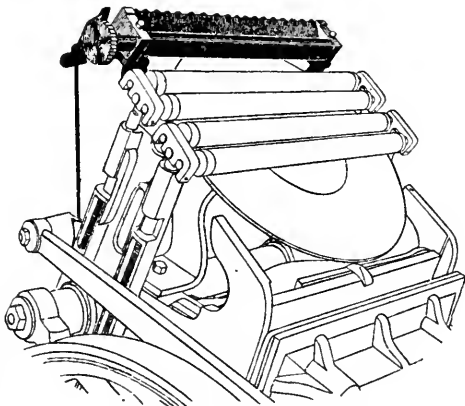

Chandler & Price Fountain.

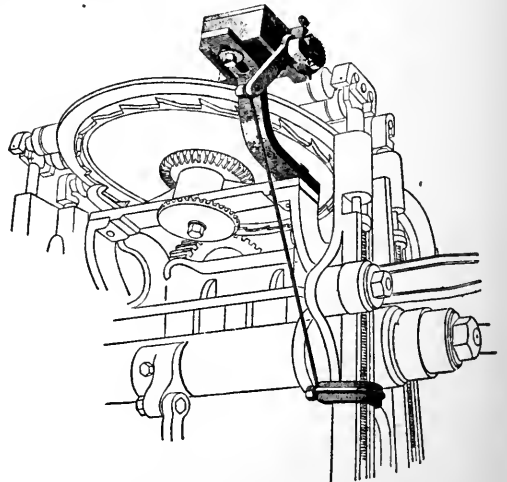

The Buckeye Fountain.

GALLY UNIVERSAL PRESS.

The Gally Universal Press is made in three styles, which are described on the following pages.

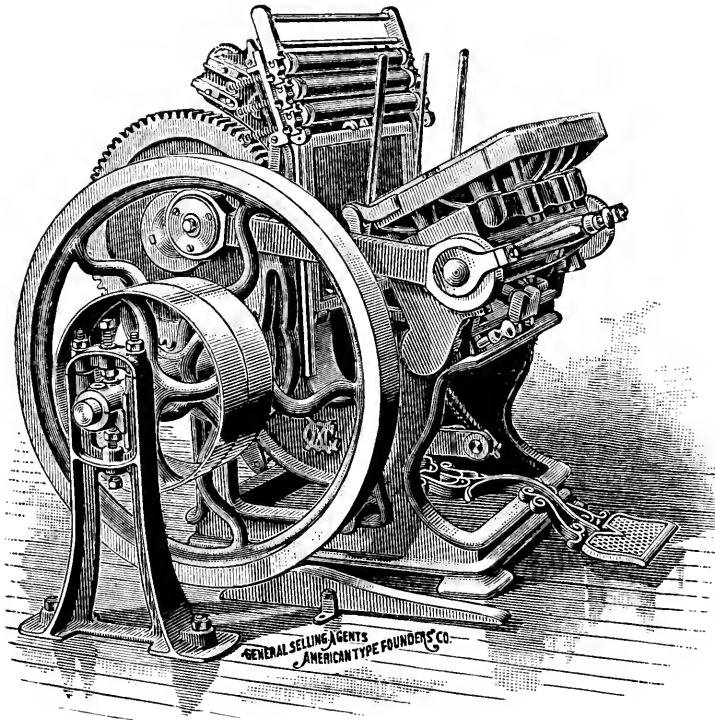

Excels all other types of platen presses because: (1) The bed and frame are cast in one piece, securing rigidity and keeping all shafts in line in spite of irregularities in floor or foundation. (2) The platen moves up squarely against the type form, giving a perfectly square impression. (3) The platen has nine supports, and is extra heavy, and is the only platen capable of sustaining the powerful impression necessary to secure the best results on large forms of cuts. (4) The impression can be thrown off instantly, the throw-off being controlled by a bar directly behind the platen. (5) The impression can be changed instantly all over the platen, varying from the imperceptible to an eighth of an inch. (6) The platen opens out widely, making it easy to feed paper into it. (7) The ink fountain is as efficient as the fountains on the highest grade cylinder presses. It is the most perfect fountain for a platen press ever made. (8) The operations of ink distribution and "inking" the form are distinct, and each performed by a separate set of rollers. In addition to the fountain ductor roller, there are four ink distributors (two of composition, two of iron) which supply two inking cylinders, from which the three form rollers receive a fresh, distributed supply of ink at each impression. On all other types of presses the form rollers have to distribute the crude ink as it leaves the fountain. (9) The form rollers can be held against the inking cylinders for distribution, while getting up color, and need not touch the type form. (10) The ink fountain can be divided by partitions for printing two or more colors at one time. (11) The weight and strength are greater than in any other platen press, as it is designed to do work that cannot be safely attempted on any other type of press.

The Gally Universal is designed for use by the best class of printers. In the hands of competent pressmen the press is the most durable, and will do first-class work in perfect register longer than any other press. We can refer purchasers to presses which have been in constant use for twenty years, doing perfect work to-day, and bidding fair to give the best results for years to come.

**PRICES OF GALLY UNIVERSAL PRESSES.
F. O. B. FACTORY.**

The following parts are included with each press: Ink fountain, power fixtures,* combination belt shifter and brake, three chases, one roller mould (for which two chases will be substituted, if preferred), six form roller stocks, four distributor roller stocks, two ductor roller stocks, twelve roller wheels (six large and six small), two iron lateral distributors, two feed tables, one small and one large wrench, one socket wrench, one chase latch wrench, and treadle fixtures. If treadle fixtures are not wanted, two chases will be sent instead.

If desired, we will cover one set of roller stocks with composition in lieu of roller mould.

* Power fixtures include fixtures on the press only.

BOXING FOR EXPORT: Quarto Medium, \$7 00; Half Medium, \$10 00; Half Super-Royal, \$15 00, net.

DESCRIPTION OF THE THREE STYLES.

STYLE No. 1.

This is the regular press, adapted for general commercial letterpress work.

| | | |
|-------------------|-------------------------------------|----------|
| Quarto Medium, | 10×15 inches inside chase | \$350 00 |
| Half Medium, | 13×19 inches inside chase | 450 00 |
| Half Super-Royal, | 14×22 inches inside chase | 515 00 |

STYLE No. 2.

This style differs from Style No. 1 in that it is more heavily built and has a steel section in large gear wheel, and is specially adapted to the finest of work.

| | | |
|-------------------|-------------------------------------|----------|
| Half Medium, | 13×19 inches inside chase | \$500 00 |
| Half Super-Royal, | 14×22 inches inside chase | 575 00 |

STYLE No. 3.

This style differs from Style No. 2 in that it is more powerful and more heavily built, and is adapted by different combinations of special devices to different kinds of special work. It has heavier fly-wheel with outside floor support and extra wide driving pulleys for wide driving-belt. This press will do successfully all kinds of regular printing-office embossing, and in its different combinations is adapted to hot or cold work.

STYLE No. 3, COMBINATION A.

For letterpress printing of the highest grade, cold embossing, stamping, and all work that can be executed on a platen set to print at the height of type.

| | | |
|-------------------|-------------------------------------|----------|
| Quarto Medium, | 10×15 inches inside chase | \$450 00 |
| Half Medium, | 13×19 inches inside chase | 600 00 |
| Half Super-Royal, | 14×22 inches inside chase | 650 00 |

STYLE No. 3, COMBINATION B.

For letterpress printing and (in addition to all work that can be done on Combination A) book-cover inlaying, and cutting and creasing. This combination is fitted with a movable 1/8-inch steel platen plate and a movable 1/8-inch brass platen plate, the latter for use in cutting and creasing.

| | | |
|-------------------|-------------------------------------|----------|
| Quarto Medium, | 10×15 inches inside chase | \$470 00 |
| Half Medium, | 13×19 inches inside chase | 626 00 |
| Half Super-Royal, | 14×22 inches inside chase | 676 00 |

STYLE No. 3, COMBINATION C.

For letterpress printing and hot embossing (in addition to all work that can be done on Combinations A and B). This combination is fitted with a steam blank and pipe connections 3/8 inch thick, movable 1/8-inch steel plate on steam blank, a movable 1/8-inch steel platen plate, a movable 1/8-inch brass platen plate, one cast-iron .475-inch platen plate, and one cast-iron .595-inch platen plate with tympan clamps attached. This combination is fitted for use with dies 1/4 inch thick.

| | | |
|-------------------|-------------------------------------|----------|
| Half Medium, | 13×19 inches inside chase | \$738 00 |
| Half Super-Royal, | 14×22 inches inside chase | 800 00 |

STYLE No. 3, COMBINATION D.

For letterpress printing, printing on wood (not exceeding one inch in thickness) and cold embossing. This combination is fitted with a 7/8-inch movable platen blank and a 1/8-inch movable steel platen plate. Cutting and creasing can be done on this combination by adding a 1/8-inch brass platen plate.

| | | |
|-------------------|-------------------------------------|----------|
| Quarto Medium, | 10×15 inches inside chase | \$474 00 |
| Half Medium, | 13×19 inches inside chase | 629 00 |
| Half Super-Royal, | 14×22 inches inside chase | 679 00 |

PRICES OF GALLY UNIVERSAL PRESSES—Continued.

STYLE No. 3, COMBINATION E.

For letterpress printing, printing on wood (not exceeding one inch in thickness) and hot embossing, and all work that can be done on Combinations A, B and C. This combination is fitted with steam blank and pipe connections, 7/8-inch movable cast-iron platen blank, one .405-inch movable cast-iron platen blank, 1/8-inch steel platen plate, a movable steel plate on steam blank and a movable 1/8-inch brass platen plate.

| | | |
|-------------------|-------------------------------------|----------|
| Half Medium, | 13×19 inches inside chase | \$738 00 |
| Half Super-Royal, | 14×22 inches inside chase | 800 00 |

SPECIAL ADAPTATIONS.

Gauges and special appliances furnished for all No. 3 Presses to order at an extra cost. The No. 3 Presses will be built to order, specially adapted to any work for which they can be used, at a reasonable extra cost to the customer.

PRICE LIST OF ATTACHMENTS FOR GALLY UNIVERSAL PRESS.

| | 10×15 Press. | 13×19 Press. | 14×22 Press. |
|---|-----------------|-----------------|-----------------|
| Ink fountain | \$20 00 | \$25 00 | \$25 00 |
| Fountain partitions, each | 4 00 | 4 00 | 4 00 |
| Power fixtures on press only | 10 00 | 10 00 | 10 00 |
| Overhead fixtures, complete | 25 00 | 30 00 | 30 00 |
| Cast-iron chases. | 2 00 | 2 25 | 2 75 |
| Wrought-iron chases | 5 50 | 6 50 | 7 25 |
| Roller stocks | 0 60 | 0 65 | 0 75 |
| American counter (fastened on left feed table, see cut page 1003) | | | 10 00 |

SPECIAL FEATURES OF THE GALLY UNIVERSAL PRESS.

TWO TYPES OF PLATEN PRESSES.

The Universal Press, when invented and patented in 1869-70, differed radically both in its fundamental principles and labor-saving appliances from any other platen press in use at that time. Since then platen presses everywhere are divided into two recognized types or classes, each taking the name of the original inventor: the "Gordon" type, with its hinged or "clam-shell" movement of bed and platen, as imitated with slight variations under a great variety of names, all distributing ink by means of a disc, and the "Gally Universal" type, with its fixed bed, sliding platen, square impact of impression on the form, solid frame and cylindrical ink distribution.

IMPRESSION.

The ideal impression is given by a Washington Hand Press, and the impression given by the Gally Universal is similar, and is perfect in practice and in theory. No other type of platen press can give a perfectly square impression.

The platen is massive, and is secured to the platen bridge by four controlling screws which pass through the bridge, and is supported at the corners and in the center by five adjustable screw supports, giving nine supports in all. Thus the utmost strength and an unyielding impression is obtained.

The platen movement in relation to the bed is illustrated in Figs. 2 and 3 (sectional drawings from the inside).

Fig. 2 shows the platen open at the feeding position, supported by the rockers (R) on the slideways (s). The movement is controlled by the draw-bars, which connect with a steel shaft (A) passing through the platen bridge. As the draw-bars pull the platen toward the bed it rocks forward until the flattened toes (e) of the rockers rest on the slideways (s), as shown in Fig. 3.

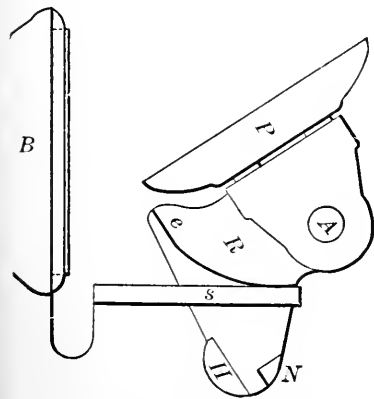

Fig. 2.

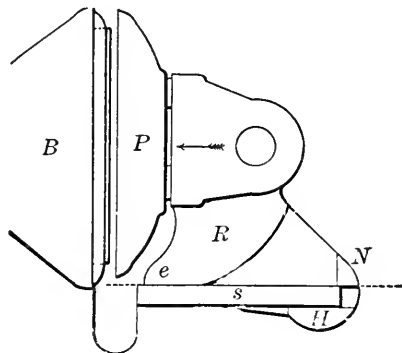

Fig. 3.

The platen is now half an inch from the type form, and exactly parallel to it, and the locking lugs (*N* and *H*) have engaged the slideways at top and bottom, preventing the platen from tipping. Thus secured, the platen slides squarely to the type form, taking a direct face impression. The platen then slides back and rocks to the feeding position again. The curve of the rockers (*R*) is struck from a point at the center of gravity of the whole moving piece, so that the movement is accomplished with a trifling expenditure of effort.

DISTRIBUTION OF INK.

The superiority of the Gally Universal Press is in no point more apparent than in the distribution and application of ink to the form. In Fig. 10 is shown the Gally Universal system of ink distribution. *C* is the main distributing cylinder, and *S* is the secondary distributing cylinder. The composition distributing rollers (*e* and *e'*) revolve on the distributing cylinders, and on top of the distributors are two metallic rollers (*v* and *v'*) with a steady lateral movement in opposite directions, constantly crossing and recrossing the lines of distribution. The ink is supplied from the fountain (*F*, Fig. 10) to the distributing cylinder (*C*), once at each impression, by the ductor roller (*H*), in an evenly spread line, immediately after the form rollers have left the cylinders to ink the form; and before the rollers have completed the rolling of the form and returned to the cylinders the applied ink is thoroughly distributed by the distributors (*e e'*), so that no undistributed ink can ever reach the form rollers or be applied to the form.

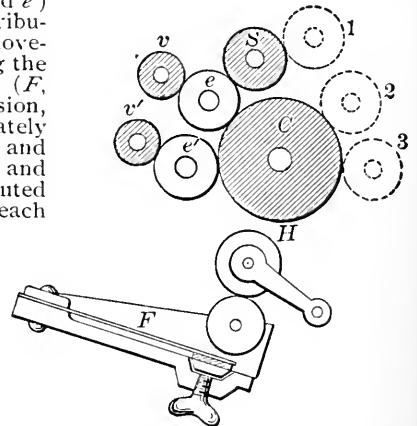

Fig. 10.

The distribution of ink is constant while the press is in motion, whether the form rollers (1, 2, 3) are in contact with cylinder or on the form. The cylinders, rollers and lateral distributors, as shown in Fig. 10, are made of different diameters on uneven measurements, so that their lines of contact are not repeated while revolving.

On presses with disc distribution the form rollers must distribute their own ink and convey it to the form, while on the Gally Universal these two functions are performed by two distinct sets of rollers. In the former case the work is necessarily imperfect; in the latter, both processes give perfect results.

INK FOUNTAIN.

The Gally Universal ink fountain is as complete as the ink fountain of any first-class cylinder press. Every part of it is under positive control. The movement of the fountain cylinder (*R*, Fig. 19) is regulated by a ratchet lever. The ink is carried from the cylinder (*R*) to the distributing cylinder *C*, Fig. 10, by a composition ductor roller. In nearly all ink fountains the regulating screws press directly against the steel blade, and in setting for a fine feed have a tendency to bind the fountain cylinder. In the Universal ink fountain (Fig. 19) *A* is a steel blade, *e* is rubber packing, and *a* is a very thin strip of steel against which the screws (*T*) are set. The rubber (*e*) furnishes an elasticity which prevents the blade from binding, while giving a perfect cut off. With this safeguard a press boy may be trusted to regulate the fountain. The fountain may be removed easily from the press to be cleansed, and is made interchangeable so that an extra fountain for colors may be put on in a few moments.

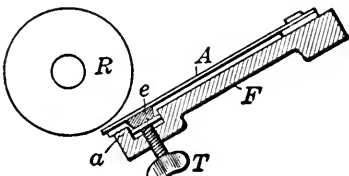
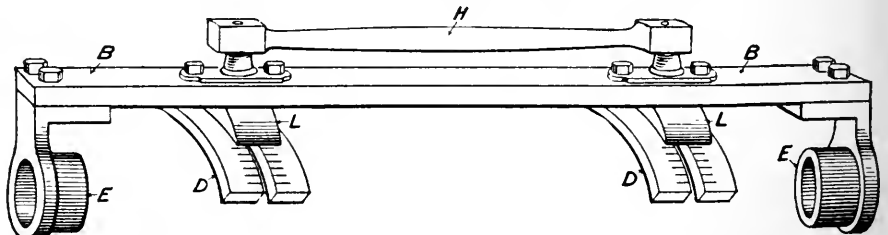

Fig. 19.

ADJUSTMENT OF IMPRESSION AND THROW-OFF.

The Gally Universal Press was the first to have a quick, easy method of adjusting the impression, and the Gally invention is still unexcelled. The theory of modern fine printing calls for a minimum of tympan packing, and to get this a fine adjustment of the platen impression is necessary. The labor as well as the inaccuracies of platen adjustment by means of the set screws make that method impracticable. Mr. Gally's invention is practically instantaneous, and allows of very fine adjustment or a total throw-off of the impression by the same device, which is located immediately behind the platen, in front of the pressman. The impression is regulated equally all over the surface of the platen by means of the adjusterslides (*L*), which can be moved up or down, increasing or decreasing impression from a tissue paper's thickness to 1/8 of an inch. These slides (*D*) are notched, and the latch, which is the lower end of the throw-off handle (*H*), engages in this notch. When it is desired to throw off impression, the handle (*H*) is pulled, the latch is disengaged, and the adjuster bar (*BB*) drops down, carrying the platen back and preventing it from taking an impression.



View of Impression Adjuster and Throw-off Bar, showing Notched Impression Adjuster Slides.

When it is desired to throw off impression, the handle (*H*) is pulled, the latch is disengaged, and the adjuster bar (*BB*) drops down, carrying the platen back and preventing it from taking an impression.

GALLY UNIVERSAL EMBOSSING PRESS.

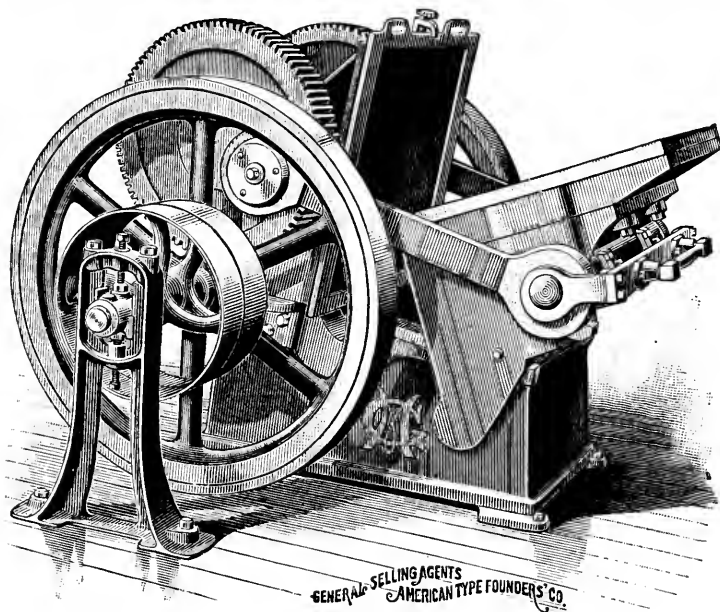

These are the largest embossing presses made, and combine strength, power, speed and facility for handling work easily in a degree unequalled by any other press. They are designed for extra heavy hot or cold process embossing, and book-cover stamping ("smashing"). The mechanical principles employed to give impression, power, and to throw-off impression, are the same as described on pages 977 and 978. Nothing better demonstrates the correctness of the mechanical principles on which Gally Universal Presses are built than their applicability to all degrees of power and strain. Every other type of platen press has its limitations—a point where it gets unwieldy and inefficient.

PRICES OF PRESS ONLY.

| | | |
|--------|--|----------|
| No. 1. | 21¼ × 22-inch bed-plate, 18 × 20 -inch chase | \$800 00 |
| No. 2. | 24 × 26-inch bed-plate, 22¾ × 24¾-inch chase | 900 00 |

PRICES OF EXTRA ATTACHMENTS.

| | |
|--|----------|
| Steam blank, complete, with pipe connections, for No. 1 Embosser, with steel die plate | \$105 00 |
| Steam blank, complete, with pipe connections, for No. 2 Embosser, with steel die plate | 118 00 |
| Steel platen plate for No. 1 Embosser | 19 50 |
| Steel platen plate for No. 2 Embosser | 26 00 |
| Cast-iron platen blank for No. 1 Embosser | 19 50 |
| Cast-iron platen blank for No. 2 Embosser | 26 00 |
| Gas blank | 200 00 |

Each press is complete with power fixtures on press.

Each press is furnished with three chases (or one cast-iron bed blank in lieu of chases, at option of purchaser), two feed tables, one wrench, one belt-shifter and one brake.

Gross weight, boxed, of embossing presses are: No. 1, 3400 pounds; No. 2, 4300 pounds.

Boxing for export: No. 1, \$10 00; No. 2, \$15 00—net.

Prices are f. o. b. factory.

GALLY UNIVERSAL STAMPING PRESS.

This is a very powerful press, built especially for stamping book covers, making signs and photo-mounts. The only fast-running press made that is sufficiently powerful to do this kind of work satisfactorily. Speed at least 1800 impressions per hour.

| | |
|---------------------------------------|-----------|
| Size of bed, 24 × 26 inches | \$1600 00 |
|---------------------------------------|-----------|

FOR HOT WORK.

| | |
|-----------------------|----------|
| Steam blank | \$150 00 |
| Gas blank | 200 00 |

GALLY UNIVERSAL PAPER-BOX CUTTING AND CREASING PRESS.

(See "Paper Box Making" at foot of this page.)

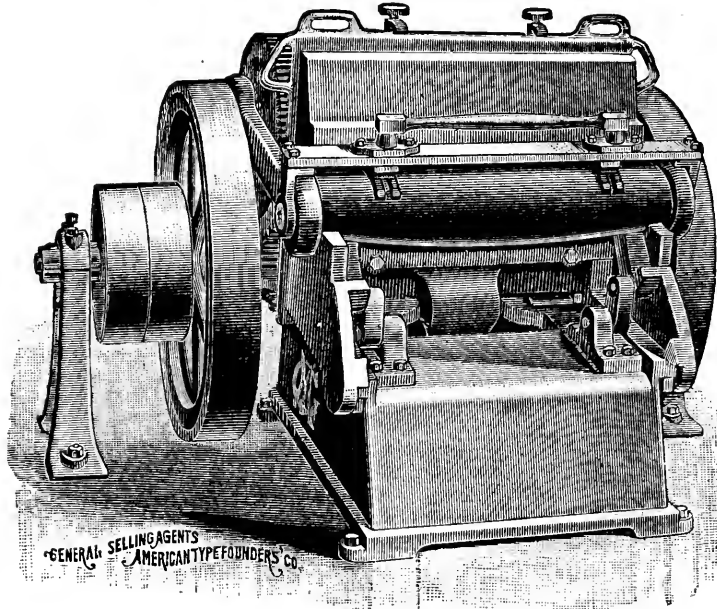

This is the only Cutting and Creasing Press on which the cutting form can be placed "out of center" without injury to the cutting rule or detriment to the work. Mr. Gally's latest patented improvement on these presses holds the platen to perfect register on an unbalanced form. This is a very important matter, as is fully understood by all those engaged in the manufacture of folding paper boxes and similar articles.

PRICES.

With Brass Platen Plate and Power Fixtures on Press.

| | | |
|----------|--|----------|
| No. 1. | 22 × 31 ¾-inch bed-plate, 20 × 30 -inch chase | \$700 00 |
| No. 1 ½. | 24 ¼ × 31 ¾-inch bed-plate, 22 ½ × 30 ¼-inch chase | 800 00 |
| No. 2. | 25 × 33 -inch bed-plate, 23 ¼ × 31 -inch chase | 900 00 |
| No. 4. | 27 ½ × 41 ½-inch bed-plate, 27 × 40 -inch chase | 1200 00 |

Prices are f. o. b. factory.

Each press is furnished with a ⅛-inch brass platen plate, three chases, two feed tables, one wrench, one belt-shifter and one brake.

Boxing for export: Nos. 1 and 1 ½, \$15 00; Nos. 2, and 4, \$20 00, net.

See page 992 for Extra Heavy Overhead Fixtures for Embossing and Cutting and Creasing Presses.

FOLDING PAPER BOX MAKING.

The process of making folding paper boxes is simple. The stock used is manilla board, made specially for the purpose. A cutting and creasing press is the same as an ordinary printing press, except that it is larger, has to be stronger, and does not require an inking apparatus. The shape of a box having been decided on, a form is set up with steel cutting and brass creasing rules—the former to cut out waste margins and to make slits, and the latter to crease or score the lines on which the stock in the box must bend when set up for use. It is usual to cut and crease as many boxes at one time as can be cut out from a full-sized sheet. The box leaves the press flat. It is then folded once and glued on one edge, and delivered flat. Any printing required is done before cutting and creasing. Any good compositor will understand the process after reading above explanation and examining a folded paper box. The glueing is done by a machine of moderate cost.

THE "PEERLESS" PRESS.

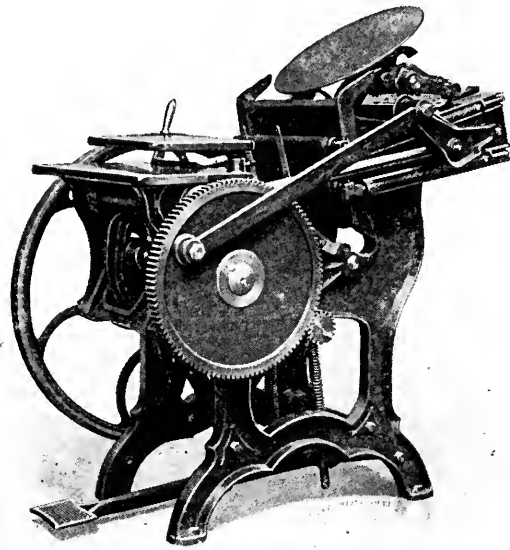

Of well-established reputation, smooth running, noiseless, easy to make-ready on, easy to feed, easy to run by treadle, with an effective throw-off, well built, exceptionally strong, and with a powerful toggle movement. The throw-off is positive and easy, and convenient to handle. The platen is sustained in the center by the toggle, and is strongest where platens are generally weakest, enabling the Peerless to do embossing and paper-box cutting and creasing, which tax a press very severely. It is a fast press.

| | | | |
|--|-----|-----------------------------------|----------|
| Eighth Medium | 8 | ×12 inches inside chase | \$225 00 |
| Large Eighth Medium | 9 | ×13 inches inside chase | 250 00 |
| Quarto Medium | 10 | ×15 inches inside chase | 300 00 |
| Large Quarto Medium | 11 | ×17 inches inside chase | 350 00 |
| Half Medium | 14 | ×20 inches inside chase | 450 00 |
| Half Super-Royal | 14½ | ×22 inches inside chase | 500 00 |
| Pony Ink Fountain, for Eighths and Quartos | | | 10 00 |
| Hinged-Well Ink Fountain, all sizes | | | 25 00 |
| Power fixtures on press, all sizes | | | 15 00 |

WRITE FOR NET PRICES.

Three chases, one impression wrench, one brayer, two sets roller trucks, one set of cast rollers, and one extra set of stocks are furnished with each press.

If desired, will send roller mould or two extra chases instead of covering one set of stocks with composition.

CHASES FOR "PEERLESS" PRESSES.

| | Cast Iron. | Steel. | | Cast Iron. | Steel. |
|-------------------------------|------------|--------|--|--------------------------------|---------------|
| 8×12 inches inside | \$1 25 | \$3 00 | | 11 ×17 inches inside | \$2 00 \$5 00 |
| 9×13 inches inside | 1 50 | 3 50 | | 14 ×20 inches inside | 2 50 5 75 |
| 10×15 inches inside | 1 50 | 4 50 | | 14½×22 inches inside | 3 00 6 00 |

SECOND-HAND PRESSES.

As a rule, second-hand presses of all makes and sizes can be supplied. Special lists of these are issued at short intervals. Those in want of second-hand machinery are invited to correspond with us. Time will be saved if correspondents will state exactly what they require.

CHALLENGE GORDON PRESS.

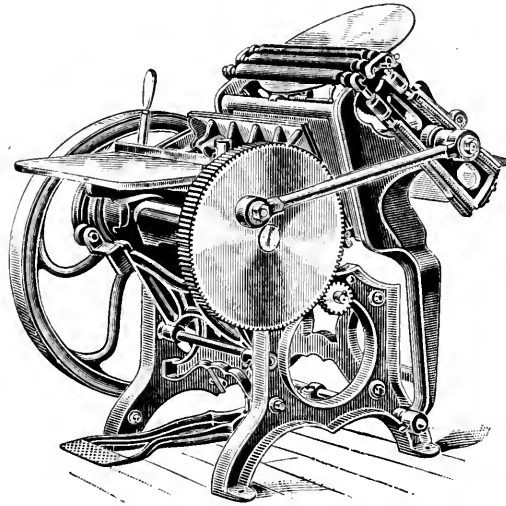

An up-to-date press, well constructed, and with all improvements found on any Gordon press.

| | |
|---|---|
| 7×11 inches inside chase . . . \$150 00 | 13 ×19 inches inside chase . . \$350 00 |
| 8×12 inches inside chase . . . 165 00 | 14 ×20 inches inside chase . . 400 00 |
| 9×13 inches inside chase . . . 225 00 | 14½×22 inches inside chase . . 450 00 |
| 10×15 inches inside chase . . . 250 00 | Power fixtures, all sizes 15 00 |
| 12×18 inches inside chase . . . 300 00 | |

Challenge Pony Fountains—For 7×11, 8×12, and 9×13 presses, \$12; for 10×15 and 12×18 presses, \$13.50; for 13×19, 14×20, and 14½×22 presses, \$15.

Challenge Full-Length Fountains—For 7×11, 8×12, and 9×13 presses, \$25; for 10×15 and 12×18 presses, \$27.50; for 13×19, 14×20, and 14½×22 presses, \$30.

With each press there are three chases, one brayer, two wrenches, one set of cast rollers, and one extra set of stocks. If desired, will send two extra chases or roller mould, instead of covering one set of stocks with composition.

PILOT HAND LEVER PRESS.

| |
|---|
| 6½×10 inches inside chase \$35 00 |
| Ink fountain 10 00 |

One chase, one set of covered rollers, and one wrench supplied with each press.

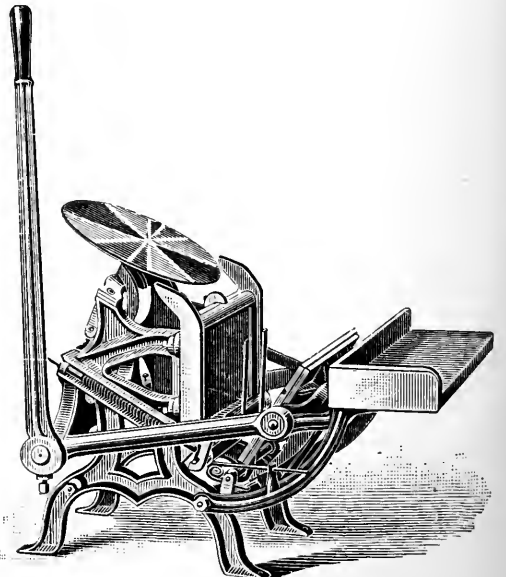

Pilot Press.

CAST ROLLERS.

For prices for casting rollers for job and cylinder presses, see page 1086.

CHALLENGE COUNTRY CYLINDER PRESS.

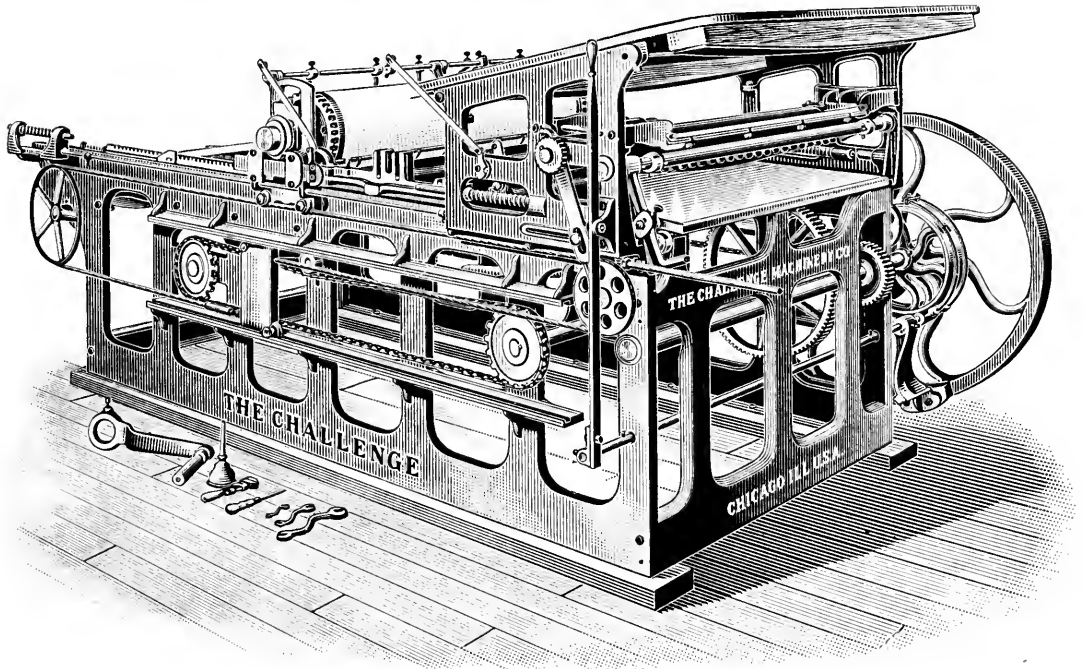

HAND-POWER SERIES.

| | Size of Paper. | Size of Bed. | Shipping Weight. | Price. |
|--------|-----------------|--------------|------------------|----------|
| No. 1. | 6-column quarto | . 33×47½ | . 3500 lbs. | \$500 00 |
| No. 2. | 7-column folio | . 27×38½ | . 2800 lbs. | 450 00 |

STEAM-POWER SERIES.

| | Size of Paper. | Size of Bed. | Shipping Weight. | Price. |
|---------|-----------------|--------------|------------------|----------|
| No. 11. | 6-column quarto | . 33×47½ | . 4500 lbs. | \$600 00 |
| No. 12. | 7-column folio | . 27×38½ | . 3750 lbs. | 550 00 |

Prices quoted are f. o. b. Chicago.

ARMY PRESS.

This is the lowest-priced press on which a newspaper of small circulation can be printed. The cylinder is stationary, but adjustable for impression by regulating screws at each end. The bed and form pass under the cylinder, and an impression is taken at each forward and backward movement.

Each press is furnished with two chases; patent quoins and key, side and foot sticks, roller frame and cast roller, oiler and wrench.

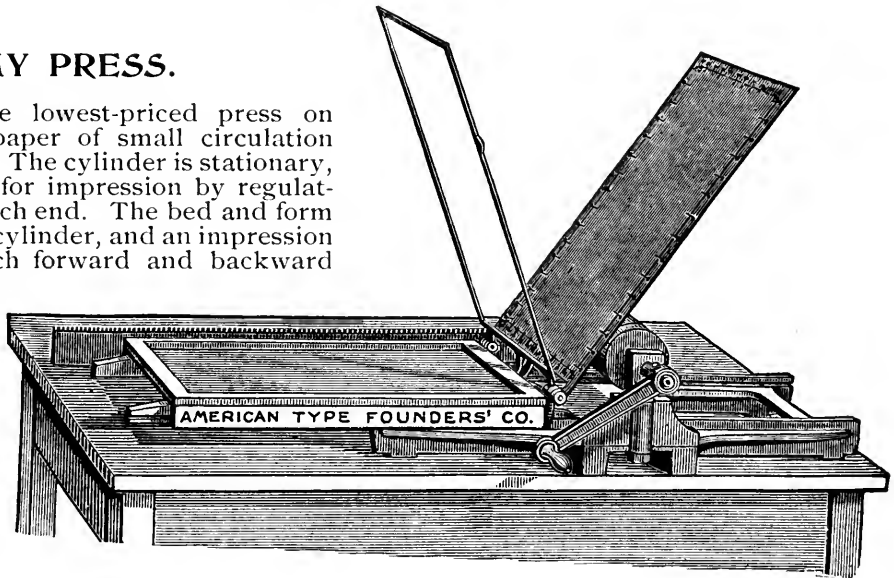

| | |
|---|----------|
| To print one page, 6-column folio, 14¾×20½ inches | \$ 60 00 |
| To print one page, 7-column folio, 16¾×22¾ inches | 85 00 |
| To print one page, 8-column folio, 19¼×25½ inches | 120 00 |
| To print two pages, 5-column folio, 19½×26 inches | 125 00 |

THE CRANSTON PRESSES.

These presses have always been built on high-grade lines. The motto of the maker, painted conspicuously in the factory, "First learn to do a thing well, then learn to do it quickly," has been consistently carried out, and it can safely be affirmed that the Cranston presses are unexcelled in fine workmanship, true mechanical principles, and superior materials, all which result in durability, smoothness, and general satisfaction. The new series of 1897 have numerous up-to-date improvements, and some sizes have been changed for the better convenience of printers. The numerous users of Cranston presses will be more than pleased with the new series.

THE CRANSTON NEWSPAPER PRESS.

**Two-Roller,
With Rack and Pinion Distribution.**

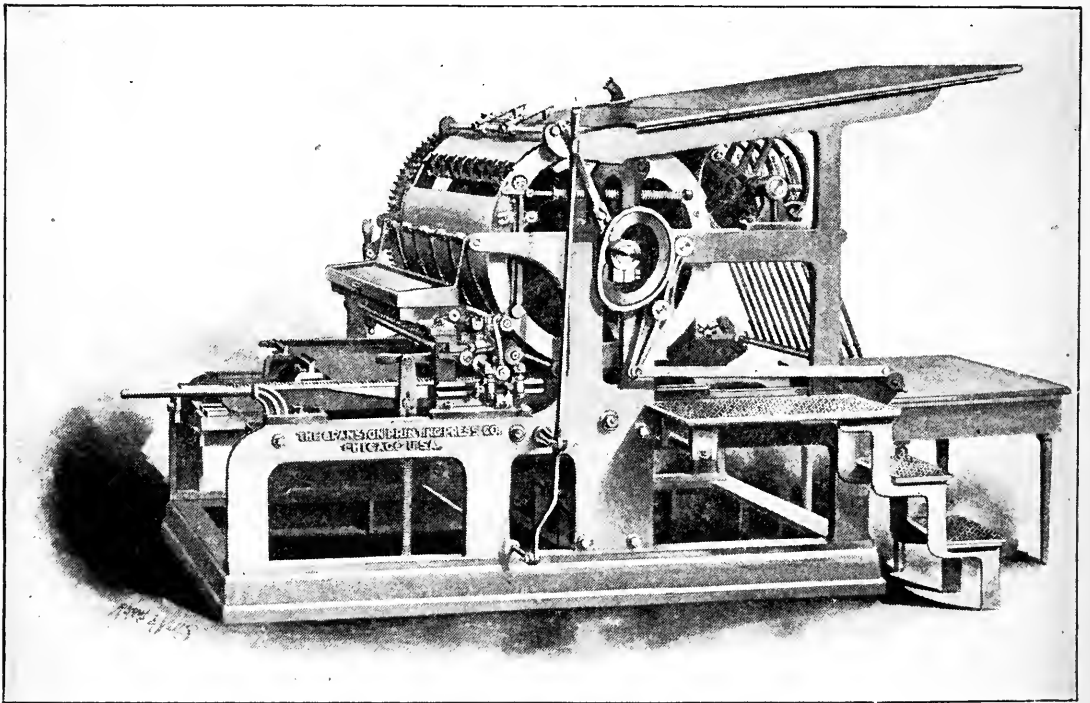

Built of the best material; furnished at a moderate price; put to practical tests;—it has proved by constant use to be an economical press to buy. The runners on both track and table are steel; the shafts, rolls, studs, shoes and wearing parts are also steel. All gears and racks are cut from the solid. The press is provided with air springs, tapeless delivery, noiseless gripper motion, continuous fly cam, adjustable feed guides. The fountain is placed high on the stand, thus giving easy access to bed of press. The form rolls are made of wrought iron pipe, and are of large size, easily placed in position and adjusted. There is a brake, a fountain cover, reel rod for blanket and tympan, and a guard for distributing rack.

| Size. | Inside Bearers. | Matter Covered. | Length of Base. | Width of Base. | Weight Boxed. | Price. |
|--------------|-----------------|-----------------|------------------|------------------|---------------|-----------|
| No. 3½ . . . | 33×48 . . . | 28×44 . . . | 7 ft. 7½ in. . . | 5 ft. 3½ in. . . | 9000 lbs. . . | \$1600 00 |

An additional charge for table distribution.

Each press is furnished with overhead fixtures complete (except when furnished with hand power only), blanket, wrenches and one set stocks, cast ready for use, also one extra set stocks and iron steps.

THE CRANSTON IMPROVED NEWSPAPER PRESS.

Two-Roller, with Rack and Pinion Distribution.

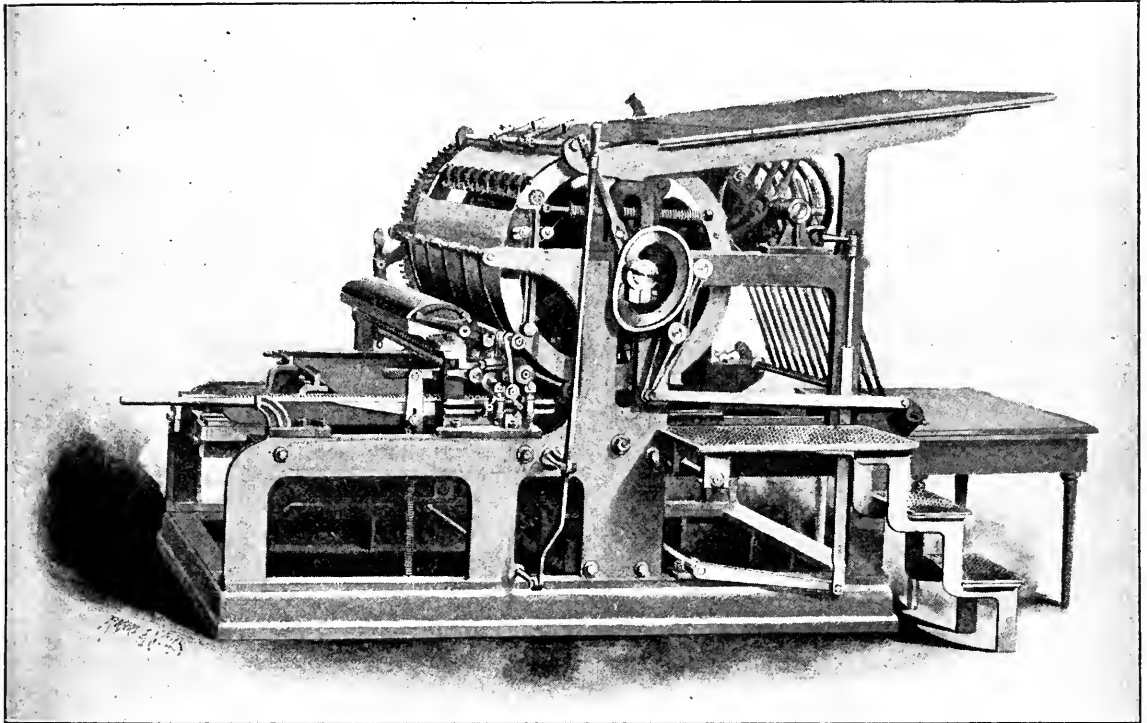

The Improved Newspaper Press has been materially changed in construction and general appearance. All racks and gears have wide faces, and are cut from the solid. The press has air springs; tapeless delivery—wheels adjustable to any size sheet; patented device for controlling motion of sliders; patent stop and reversing motion; noiseless gripper motion; continuous fly cam; feed guides that are capable of the finest adjustment; large size form rollers; long register rack and segment; deep fountain; cover for fountain; convenient arrangement for adjusting fountain roll; cylinder distribution.

Every convenient feature that the price at which it is offered will permit is put on this press, effecting a saving of time and labor for which the Cranston presses are well and favorably known.

| Size. | Inside Bearers. | Matter Covered. | Length of Base. | Width of Base. | Weight Boxed. | Price. |
|---------------------------|-----------------|-----------------|------------------|------------------|---------------|-----------|
| No. 3½ . . . | 33×48 . . . | 28×44 . . . | 7 ft. 7½ in. . . | 5 ft. 3½ in. . . | 9500 lbs. . . | \$1800 00 |
| Table distribution extra. | | | | | | |

Each press is furnished with overhead fixtures complete, blanket or hard packing, wrenches, iron steps, two complete sets stocks—one set cast with composition ready for immediate use.

THE CRANSTON IMPROVED BOOK AND NEWSPAPER PRESS.

Two-Roller, with Rack and Pinion Distribution.

The Improved Book and Newspaper Press has all of the features which made the Improved Newspaper Press the best newspaper press in the market, and in addition has a separate heavy cast-iron base plate which gives additional strength and solidity to the machine, and makes it possible to run it at a higher rate of speed without jar or injury to the press. It is especially designed for fine book, newspaper and general job printing. For accuracy of register and convenience of making ready it is unexcelled. The workmanship and wearing qualities are unsurpassed.

| Size. | Inside Bearers. | Matter Covered. | Length of Base. | Width of Base. | Weight Boxed. | Price. |
|-------------------------------------|-----------------|-----------------|------------------|------------------|-----------------|-----------|
| No. 3½ . . . | 33×48 . . . | 28×44 . . . | 7 ft. 7½ in. . . | 5 ft. 3½ in. . . | 10,000 lbs. . . | \$2200 00 |
| Table distribution, extra | | | | | | 100 00 |

Each press is furnished with overhead fixtures complete, blanket or hard packing, wrenches, iron steps, two complete sets stocks—one set cast with composition ready for immediate use.

THE CRANSTON PATENT IMPROVED TWO-ROLLER PRINTING PRESS.

For Fine Book, Commercial and Newspaper Printing.

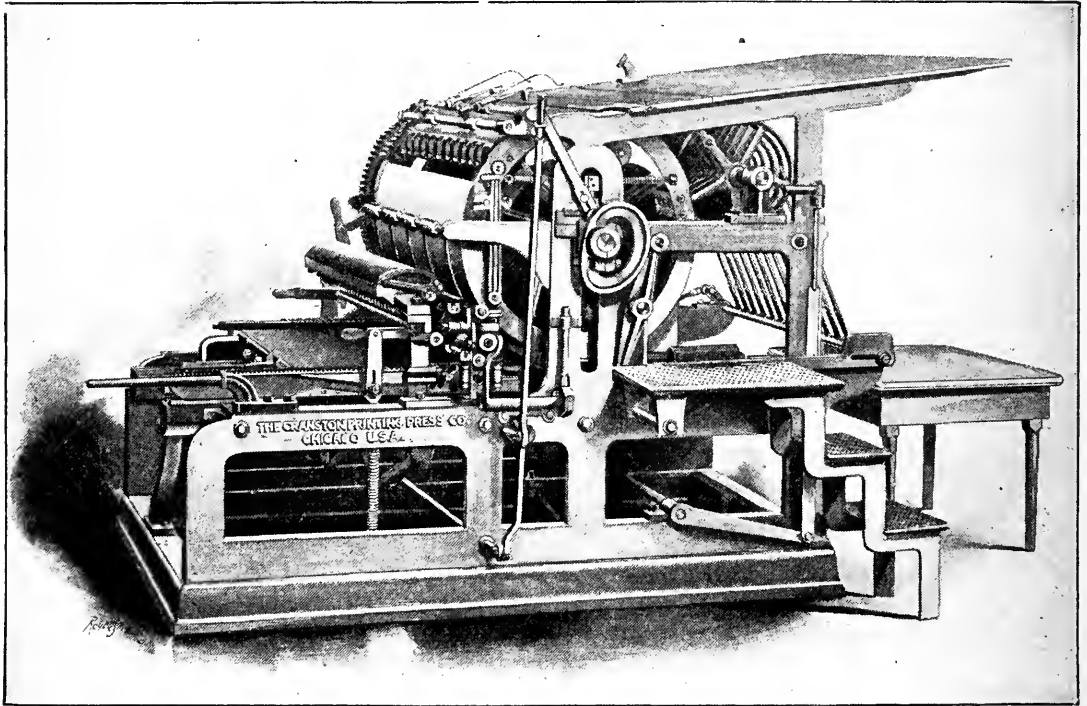

This press is carefully made in every detail. The stock and finish are unexcelled. The tracks are wide, and provided with steel rolls and runners. The wearing parts—shafts, knuckles, shoes, studs—are of steel. The gears and racks are cut from the solid, and have wide faces. The press has air springs; patent silent slider motion, which insures uniform travel of the sliders with the table; patent stop and reversing motion; improved feed guides; patent adjustable side-guide leaf on feed table, which can be set for the greatest precision of register.

The fly is operated by a silent motion, the cam having a continuous surface.

The fountain basin is deep, and will carry a large supply of ink. It is placed high on the stands, and easy access is thus given to the bed of the press.

The Cranston combines the essential features: great strength, unyielding impression, fine distribution, exact register, with convenience in adjustments and make-ready. It is operated with light power, and cannot but give satisfaction both in quantity and quality of work produced.

| Size. | Inside Bearers. | Matter Covered. | Length of Base. | Width of Base. | Weight Boxed. | Price. |
|-------------------|-----------------|-----------------|-----------------|----------------|---------------|--------|
| *No. 1 | 21 × 28 | 16 × 24 | 5 ft. 8¾ in. | 3 ft. 8¼ in. | 5,500 | — |
| *No. 1½ | 21 × 36 | 16 × 32 | 5 ft. 8¾ in. | 4 ft. 4½ in. | 6,500 | — |
| *No. 1A | 24 × 30 | 19 × 26 | 6 ft. 2½ in. | 3 ft. 10¼ in. | 6,500 | — |
| No. 2A | 25 × 38 | 22 × 34 | 6 ft. 8¾ in. | 4 ft. 7¾ in. | 8,500 | — |
| No. 2½ | 29 × 43 | 24 × 39 | 7 ft. 4½ in. | 5 ft. — | 10,000 | — |
| No. 3½ | 33 × 48 | 27 × 44 | 7 ft. 9¾ in. | 5 ft. 5 in. | 11,000 | — |

*Commercial Series.

Each press is furnished with overhead fixtures complete, blanket and hard packing, wrenches, iron steps, and two complete sets stocks—one set cast with composition and ready for immediate use.

THE CRANSTON-VICTOR COMMERCIAL PRESS.

Two-Revolution, with Four Rollers.

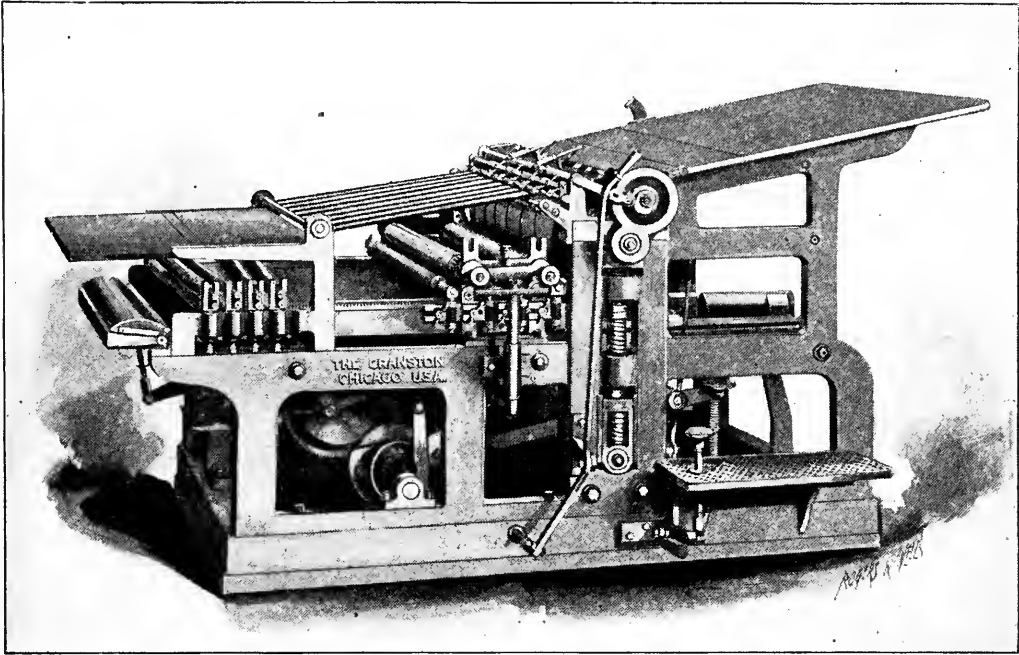

Various methods of engraving having been developed, and their utility practically demonstrated, the demand has been created for a press that will bring out delicate lines of half-tone, process, etched, photo-engraved plates, and work of this description, giving that clear and distinct impression without which the best results are not attainable from such plates. The new Victor Two-Revolution Four-Roller Commercial Press is especially designed for this class of work. Possessing as it does the patented features of our larger sizes, it is, like them, solidly constructed, giving an *unyielding impression* and an *ample inking surface*. Its size is convenient and sufficiently large to meet all demands for work of this class, while the speed provides for rapid production. Many features are embodied in this press for convenience in make-ready, etc. The distribution is a complete system, by means of which every particle of inking surface is *evenly* and *thoroughly* covered. The movements are easily adjusted and positive in their action. The cam has a continuous surface, and the sheets are laid lightly on the table without smut or off-set. Adjustable fly-fingers. The height of the press is such that it can be fed from the floor, and it is built with special reference to convenience in working about it. Its register is *faultless*. This press is the result of careful study, and embodies suggestions from practical printers regarding the requirements for printing this special work. The very satisfactory results obtained from those in use prove conclusively that the Victor will meet all requirements made upon it.

The speed is equal to all reasonable demands for fine printing.

| Size. | Inside Bearers. | Matter Covered. | Length of Base. | Width of Base. | Weight Boxed. | Price. |
|------------|-----------------|-----------------|-----------------|----------------|---------------|--------|
| No. 2A . . | 26×38 in. . | 21½×34 in. . | 6 ft. 5¾ in. . | 4 ft. 5¾ in. . | 7500 lbs. . . | ————— |

Each press is furnished with overhead fixtures complete, blanket or hard packing, wrenches, two complete sets stocks—one set cast ready for immediate use.

A WISE PURCHASE.

The No. 2A Cranston-Victor Press is a money-maker. Fine job printing, from small circulars to any size within its capacity, can be done at high speed and with the finest results. In a printing establishment doing general work of all grades this press will prove exceedingly useful and profitable. Its construction and features are such that making ready can be done quickly. It takes in a great range of work which cannot be so profitably printed on a larger press.

THE CRANSTON-VICTOR TWO-REVOLUTION PRESS.

Two-Roller.

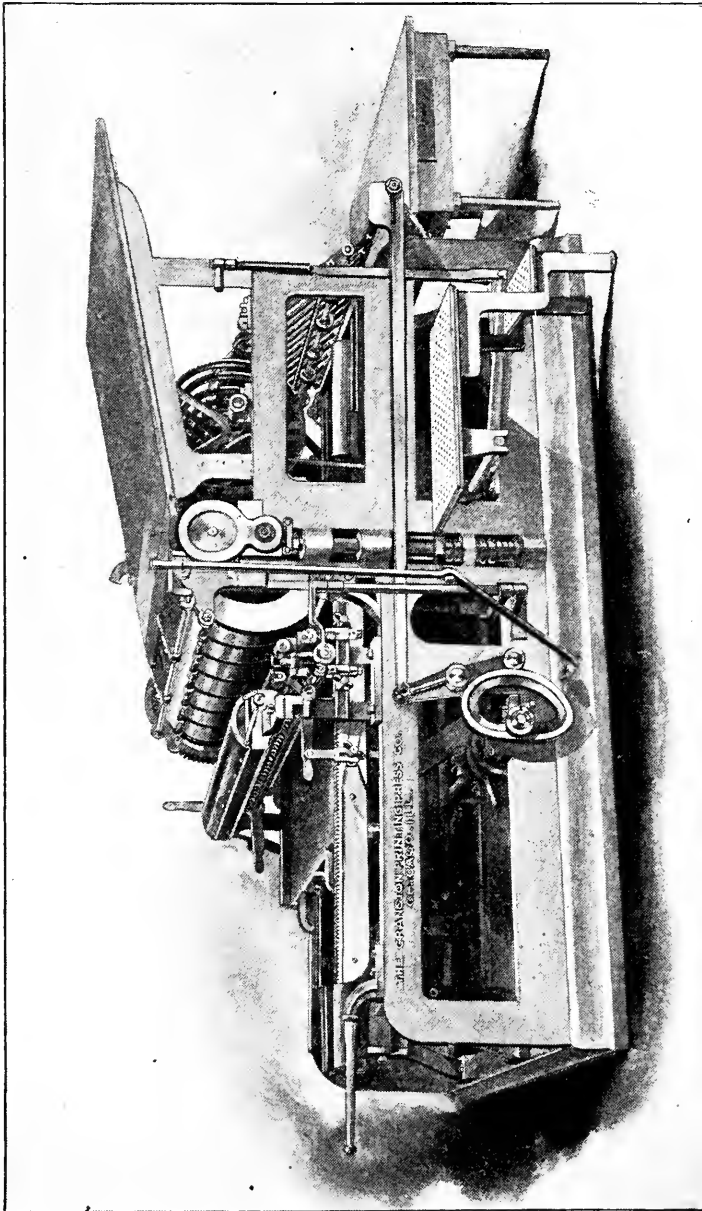

The track has wide runners, laid with steel. The table has three supports—two in the track, one on a center bearing placed on the girt—thus giving three continuous bearings through the line of impression without interference of a third track. Cylinder and lifting shafts, rolls, shoes, knuckles, are of steel. The smaller parts are built with a view to the greatest possible wear.

The mechanism for lifting the cylinder is simple, effective, and controlled by cam movements. No strain and no wear. Steel bearings.

The press has air springs; patent device for controlling motion of sliders; all gears and racks have wide faces, and are cut from the solid; distribution unailing; large-size form rollers, with bearings convenient and secure, easily placed in position and as easily removed; fly cam with continuous surface; deep fountain basin; arrangement for adjusting fountain roll; cover for fountain; adjustable bearers; hard-wood feed table; patent improved feed

guides and side-guide leaf on feed table; patent stop and reversing motion; automatic leaf-lifting device for preventing the tongues or guides from catching and tearing the tympan while reversing press; arrangement for throwing reel wheels on or off while making ready. The movements are all conveniently and easily adjusted, and positive in their action.

The speed of this press is all that can be obtained from any press of corresponding size and style.

| Size. | Inside Bearers. | Matter Covered. | Length of Base. | Width of Base. | Weight, Boxed. | Price. |
|------------------|------------------------|------------------------|----------------------------|-----------------------------|---------------------|--------|
| No. 2A | 26×38 inches | 22×34 inches | 6 feet 5¼ inches | 4 feet 5¼ inches | 7,500 lbs. | _____ |
| No. 4 | 34×50 inches | 30×46 inches | 8 feet 6 inches | 5 feet 7½ inches | 14,500 lbs. | _____ |
| No. 5½ | 38×54 inches | 34×50 inches | 9 feet 6½ inches | 5 feet 11½ inches | 16,000 lbs. | _____ |

Each press is furnished with overhead fixtures complete, blanket or hard packing, wrenches, iron steps, two complete sets stocks—one set cast with composition ready for immediate use.

The entire frame of the press is solid and compact. The tracks on both the table and runners are wide, laid with steel, and the rolls traversing on them are of the same material accurately gauged to size. The lifting mechanism for the cylinder is a direct cam motion, plain in construction, smooth running, operated with light power, requiring no weight. The shafts, cams, knuckles, studs, rolls, shoes, and all wearing parts, are of steel, and built with view of greatest possible resistance to wear. The shoes are securely fastened and doweled to the rack hangers. The cylinder has heavy flanges. The impression surface is strongly braced and supported. The press has hard-wood feed table; fly cam with continuous surface. Ample provision is made securing distribution and register. This is a press that can be easily handled, with movements plain and direct in action, adjustments readily and conveniently made, resulting in the greatest economy of time and labor.

This press is provided with a trip, which may be thrown on or off at any point of the stroke of bed. The reciprocating motion of the table is controlled by air springs which are simple and effective, having a plain valve which is in itself direct acting without any complicated attachments. The sheets are delivered to the fly by the tape-roller, which is as practicable on all our presses, the uniformity in travel is thereby insured. The patent stop and reversing motion enables the feeder to stop the press instantly at any desired point, and run it backward, thereby effecting economy of time and labor, as he has absolute control of the press without leaving his position. The automatic leaf-lifting device prevents the tongues or guides from catching or tearing the tympan while reversing press.

less delivery. The down-delivery attachment gives a positive and unfailling delivery of sheets on the fly table. As far as practicable on all our presses, the adjustments are made with thumb nuts. The sliders are attached to the table by our patent slider motion, and uniformity in travel is thereby insured. The patent feed guides and adjustable side-guide leaf on feed table can be adjusted with the utmost precision without leaving the feeder's platform. Reel wheels are readily thrown on or off while making ready. The patent stop and reversing motion enables the feeder to stop the press instantly at any desired point, and run it backward, thereby effecting economy of time and labor, as he has absolute control of the press without leaving his position. The automatic leaf-lifting device prevents the tongues or guides from catching or tearing the tympan while reversing press.

THE CRANSTON-VICTOR TWO-REVOLUTION PRESS.

Four-Roller.

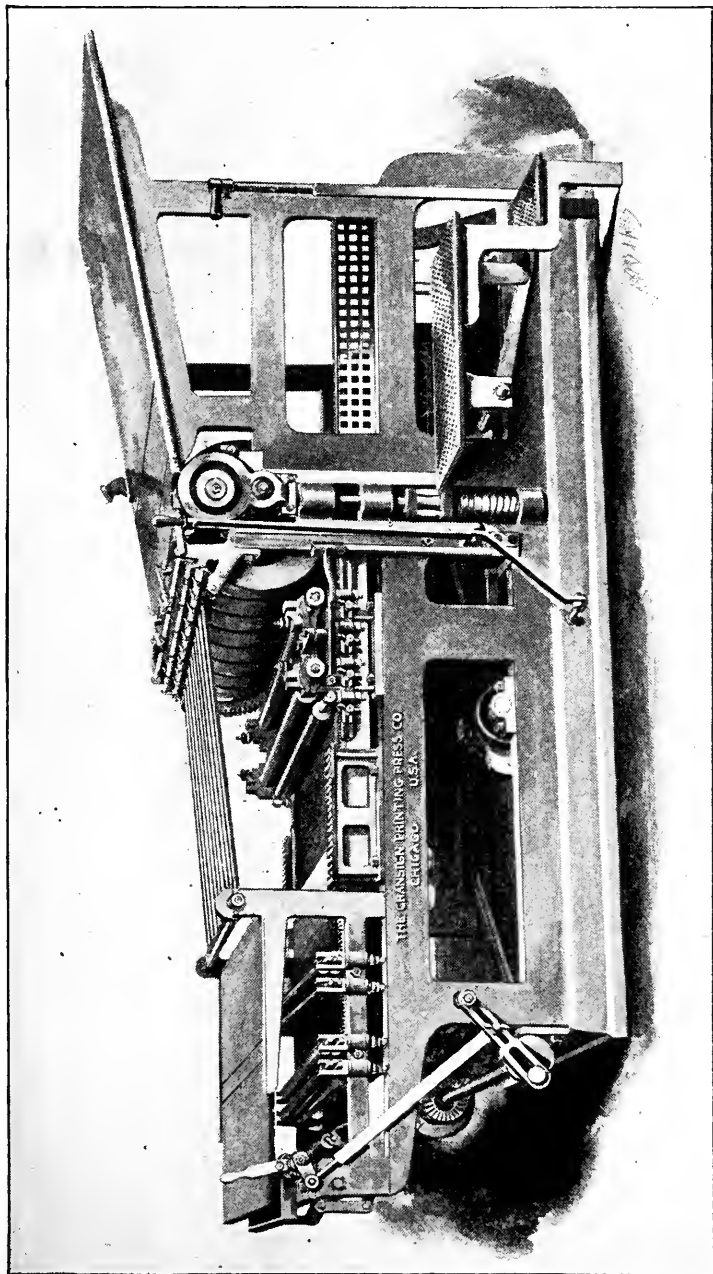

less delivery. The down-delivery attachment gives a positive and unfailling delivery of sheets on the fly table. As far as practicable on all our presses, the adjustments are made with thumb nuts. The sliders are attached to the table by our patent slider motion, and uniformity in travel is thereby insured. The patent feed guides and adjustable side-guide leaf on feed table can be adjusted with the utmost precision without leaving the feeder's platform. Reel wheels are readily thrown on or off while making ready. The patent stop and reversing motion enables the feeder to stop the press instantly at any desired point, and run it backward, thereby effecting economy of time and labor, as he has absolute control of the press without leaving his position. The automatic leaf-lifting device prevents the tongues or guides from catching or tearing the tympan while reversing press.

| Size. | Inside Bearers. | Matter Covered. | Length of Base. | Width of Base. | Weight Boxed. | Price. |
|--------|-----------------|-----------------|------------------|-------------------|---------------|--------|
| No. 2½ | 30×47 inches | 26×43 inches | 9 feet 6½ inches | 5 feet 7½ inches | 14,000 lbs. | — |
| No. 4 | 34×50 inches | 29×46 inches | 9 feet 6½ inches | 5 feet 7½ inches | 17,500 lbs. | — |
| No. 5½ | 38×54 inches | 34×50 inches | 9 feet 6½ inches | 5 feet 11½ inches | 18,500 lbs. | — |

Each press is furnished with overhead fixtures complete, blanket or hard packing, wrenches, iron steps, two complete sets stocks—one set cast with composition ready for immediate use.

COTTRELL TRIUMPH COUNTRY PRESS.

With Patent Air Springs.

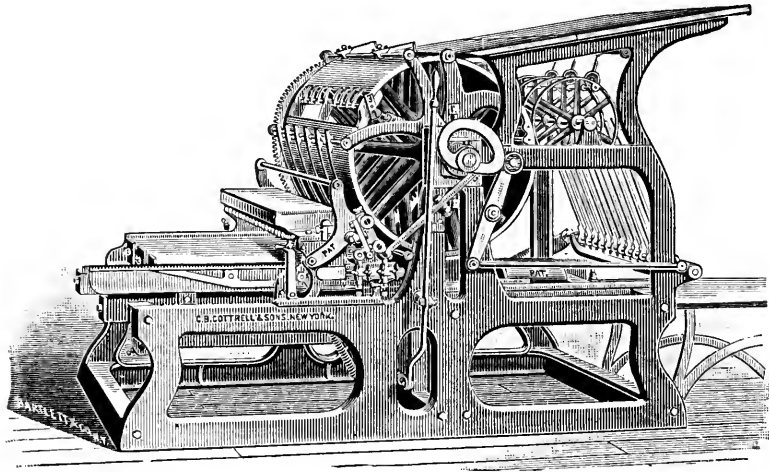

Adapted for printing newspapers, pamphlets, posters, circulars, and all classes of commercial printing. Conforms in construction, design, durability and finish to the high reputation of the manufacturers.

The press is supplied with patent air springs, the resistance of which is increased or decreased according to the speed of the press. It is well known that the faster the speed the greater strength of spring is required. The patent air spring covers these requirements. If the press is running at five hundred per hour, the spring can be easily regulated for that speed; and if running at fifteen hundred per hour, the proportionate increase of spring can be obtained, and so up to the highest speed of which this press is capable. The air spring is provided with an automatic throw-off that releases the pressure when the press is stopped, and the pressman can move the bed to and fro without compressing the spring. When the press is started, the spring is applied automatically.

The patent hinged roller-frame permits of the rollers being instantly uncovered for removal or for other purposes without unscrewing the sockets. The rollers can be taken out and put back without changing their set. The well-fountain is used, being easily regulated and cleansed, and it is set high, giving easy access to the form. The distribution is ample—two three-inch rollers covering the full form. The bed has four supports while under impression, thus securing a clear, even impression. The shoes, tracks and rollers are of hard steel. The gearing is accurately cut, which, together with the registering rack and segment, insures perfect register.

The Triumph Press is built with table, rack and cam distribution, or with the rack and cam distribution, as per illustration on this page.

The Triumph Press can be fitted to run by hand power, when so desired. Tapeless delivery furnished, when required, at an extra charge.

Sizes and List Prices with Rack and Cam Distribution.

| | Size of Bed Inside Bearers. | Size of Form Covered by Rollers. | List Price. |
|-----------------|--------------------------------|-------------------------------------|----------------|
| No. 3 | 26×37 inches | 22×33 inches | \$1000 00 |
| No. 5 | 33×47 inches | 28×43 inches | 1100 00 |

Steam fixtures, extra, \$50 00. Tapeless delivery, extra, \$75 00. Table, rack and cam distribution, extra, \$75 00.

Price includes rubber blanket, wrenches, two sets of roller stocks, roller moulds, boxing and shipping.

COTTRELL MONARCH TWO-ROLLER PRESS.

With Two Rollers Covering Form.

Air Springs.
Tapeless Delivery.

Back-Up Movement.
Hinged Roller-Frame.

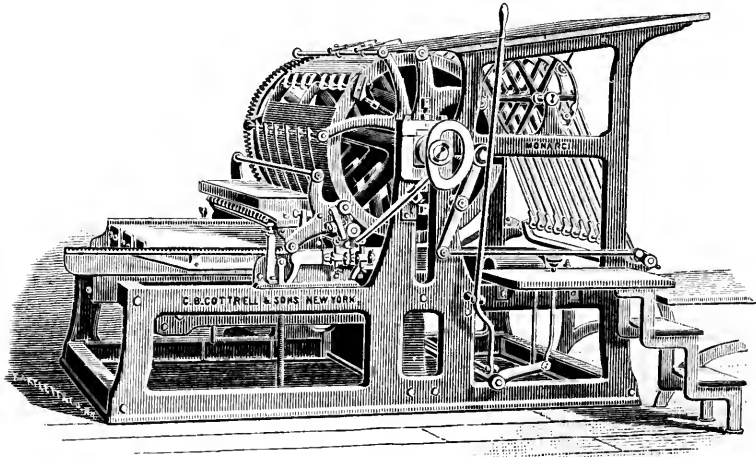

It has many advantages and improvements, including patent air springs, patent tapeless delivery, back-up movement, hinged roller-frame, and iron steps and feeder's stand, and in its manufacture quality is placed first and cost afterward.

It is a press of excellent design, of the best materials, and of high speed. By manufacturing them in large quantities, and building but two sizes, the price is put within the reach of the printer of moderate means.

It is a fast press—1600 per hour is easily possible on the larger and 2000 on the smaller size.

It has four bearings under the bed for extreme rigidity and strength, and steel tracks and steel rollers. There is a heavy flange on the ends of the cylinder as an added element of strength.

The patent air spring forms an easy cushion for the bed in passing the centers, is under perfect control, and can be readily adjusted for the different speeds. The air spring has a new automatic throw-off, so that in turning over the centers by hand the spring is not compressed.

The patent back-up movement is a great convenience and a labor-saver.

The patent hinged roller-frame permits the form rollers to be instantly uncovered for removal or other purposes without unscrewing the sockets. The rollers can be taken out and put back without changing their set.

The well fountain is used, being easily regulated and cleaned. It is set high, giving easy access to the form.

Furnished with table and rack and cam distribution at an extra charge, or only with rack and cam distribution as illustrated.

Sizes and List Prices, with Rack and Cam Distribution.

| Size of Bed Inside of Bearers. | Size of Form Covered by Two Rollers. | List Price. |
|-----------------------------------|---|----------------|
| No. 3, 26×37 inches | 22×33 inches | \$1500 00 |
| No. 5, 33×47 inches | 28×43 inches | 1800 00 |

Table distribution, \$75 00 extra.

Price includes hard-packing or rubber blanket, wrenches, two sets of composition roller stocks, roller moulds, countershaft, two hangers, two four-speed cone pulleys and driving pulley, boxing and shipping.

COMBINATION PAPER JOGGER.

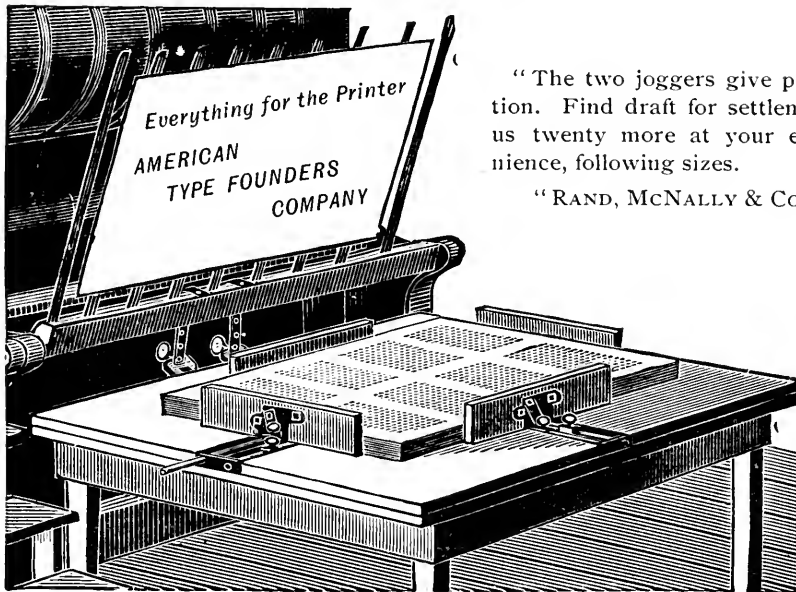

“The two joggers give perfect satisfaction. Find draft for settlement, and send us twenty more at your earliest convenience, following sizes.

“RAND, McNALLY & Co., Chicago.”

Made with wings, to be instantly removed if desired. No projecting rod on front side to tear clothes. This of itself is worth the price of a jogger. Patent attachable wings for small joggers, by which letter-heads, etc., can be evened up.

| | | |
|--------------------------|-------|---------|
| 24×36 inches, or less | | \$15 00 |
| 36×48 inches, or less | | 18 00 |
| Larger than 36×48 inches | | 20 00 |

OVERHEAD POWER FIXTURES.

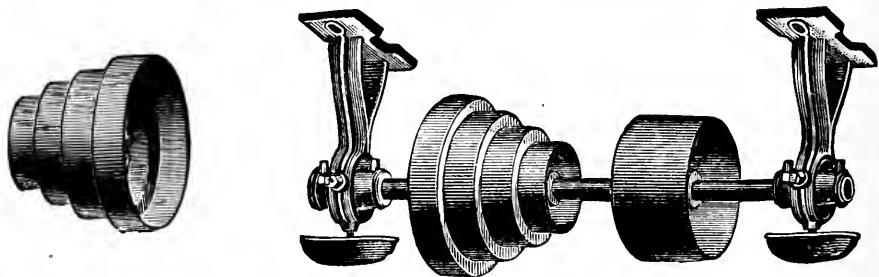

Overhead Fixtures consist of countershaft, two self-adjusting hangers with oil cups, two cone pulleys and driving pulley. Send size and speed of driving shaft with your order. Driving pulley of different diameter will be furnished, if necessary, to insure proper speed.

If the cone pulley for line shaft is wanted “split,” add 10 per cent. to prices quoted below.

All sizes and styles of pulleys, hangers, shafting, etc., furnished at bottom prices. (See Condensed Price List on following page.)

OVERHEAD FIXTURES FOR JOB PRESSES.

| | | Belt. | Driving Pulley. | Shipping Weight. | List Price. |
|----------------------|-----------------|-----------|-----------------|------------------|-------------|
| Light 3-speed cones, | 6 to 9 inches | 1½ inches | 8 inches | 110 lbs. | \$15 00 |
| Light 4-speed cones, | 7 to 10 inches | 1½ inches | 8 inches | 125 lbs. | 18 00 |
| Heavy 3-speed cones, | 8 to 10 inches | 2 inches | 8 inches | 155 lbs. | 20 00 |
| Heavy 4-speed cones, | 4¼ to 8¾ inches | 2 inches | 8 inches | 160 lbs. | 22 50 |
| Heavy 3-speed cones, | 9 to 12 inches | 2½ inches | 12 inches | 185 lbs. | 22 00 |
| Heavy 4-speed cones, | 7 to 10 inches | 2¼ inches | 12 inches | 190 lbs. | 25 05 |
| Heavy 3-speed cones, | 10 to 13 inches | 2½ inches | 12 inches | 190 lbs. | 27 50 |
| Heavy 4-speed cones, | 10 to 13 inches | 2½ inches | 12 inches | 225 lbs. | 30 00 |

EXTRA HEAVY OVERHEAD POWER FIXTURES

For Universal Embossers, Cutters and Creasers, and Large Cylinder Presses.

Heavy 3-speed cones, 12 to 15 inches, 3½-inch belt, 16-inch driving pulley; weight, 400 pounds \$40 00

CONDENSED PRICE LIST OF PULLEYS, HANGERS, SHAFTING AND BELTING.

FINISHED IRON PULLEYS.

| Diameter. | 6 in. | 7 in. | 8 in. | 10 in. | 12 in. | 14 in. | 16 in. | 20 in. | 24 in. | 30 in. | 36 in. |
|-------------------------|--------|--------|--------|--------|--------|--------|--------|--------|--------|--------|---------|
| Face 3 inches | \$1 95 | \$2 10 | \$2 25 | \$2 55 | \$2 85 | \$3 25 | \$3 60 | \$4 45 | \$5 40 | \$7 60 | \$10 40 |
| Face 4 inches | 2 10 | 2 25 | 2 45 | 2 75 | 3 15 | 3 55 | 3 95 | 4 95 | 6 10 | 8 55 | 11 40 |
| Face 5 inches | 2 30 | 2 50 | 2 70 | 3 05 | 3 50 | 3 90 | 4 40 | 5 55 | 6 85 | 9 45 | 12 65 |
| Face 6 inches | 2 55 | 2 75 | 2 95 | 3 40 | 3 85 | 4 35 | 4 90 | 6 20 | 7 65 | 10 55 | 14 10 |

ADD TO ABOVE FOR SPLIT PULLEYS.

| Diameter. | 6 and 7 in. | 8 to 10 in. | 12 to 16 in. | 20 in. | 24 to 30 in. | 36 in. |
|-------------------------|-------------|-------------|--------------|--------|--------------|--------|
| Face 3 inches | Not made | \$1 30 | \$1 50 | \$2 65 | \$3 60 | \$4 50 |
| Face 4 inches | Not made | 1 75 | 2 20 | 2 65 | 3 60 | 4 50 |
| Face 5 inches | Not made | 1 75 | 2 20 | 3 40 | 4 40 | 5 60 |
| Face 6 inches | Not made | 1 75 | 2 20 | 3 40 | 4 40 | 5 60 |

SPLIT WOOD PULLEYS.

| Diameter. | 3 in. | 4 in. | 5 in. | 6 in. | 7 in. | 8 in. | 10 in. | 12 in. | 14 in. | 16 in. | 20 in. | 24 in. | 30 in. | 36 in. |
|--------------------|--------|--------|--------|--------|--------|--------|--------|--------|--------|--------|--------|--------|--------|---------|
| Face 2 in. | \$1 80 | \$1 90 | \$2 00 | \$2 10 | \$2 20 | \$2 35 | | | | | | | | |
| Face 3 in. | 1 90 | 2 00 | 2 10 | 2 20 | 2 30 | 2 45 | \$2 80 | \$3 15 | \$3 45 | \$3 80 | \$4 60 | \$5 50 | \$7 70 | \$10 30 |
| Face 4 in. | 2 00 | 2 10 | 2 20 | 2 35 | 2 45 | 2 60 | 3 00 | 3 40 | 3 70 | 4 15 | 5 20 | 6 20 | 8 60 | 11 70 |
| Face 5 in. | 2 10 | 2 20 | 2 40 | 2 55 | 2 65 | 2 80 | 3 25 | 3 65 | 4 00 | 4 50 | 5 80 | 7 00 | 9 50 | 13 10 |
| Face 6 in. | 2 25 | 2 40 | 2 60 | 2 75 | 2 85 | 3 00 | 3 50 | 3 90 | 4 35 | 5 00 | 6 40 | 7 80 | 10 60 | 14 60 |
| Face 7 in. | | | | 3 00 | 3 10 | 3 25 | 3 75 | 4 20 | 4 70 | 5 50 | 7 00 | 8 60 | 11 80 | 16 10 |
| Face 8 in. | | | | 3 25 | 3 35 | 3 50 | 4 00 | 4 55 | 5 10 | 6 00 | 7 60 | 9 40 | 13 00 | 17 70 |

ADJUSTABLE BALL AND SOCKET HANGERS.

| Drop. | 8 in. | 10 in. | 12 in. | 14 in. | 16 in. | 18 in. |
|-----------------------|--------|--------|--------|--------|--------|--------|
| Bore 1¾/16 | \$4 20 | \$4 40 | \$4 60 | \$4 90 | | |
| Bore 17/16 | 4 50 | 4 60 | 4 90 | 5 20 | \$5 80 | \$6 40 |
| Bore 111/16 | 4 70 | 5 10 | 5 50 | 5 90 | 6 25 | 6 50 |
| Bore 115/16 | | 6 00 | 6 50 | 7 00 | 7 50 | 7 70 |

SHAFTING.

| Size. | Weight per foot. | Price per lb. |
|------------------|------------------|---------------|
| 1¾/16 | 3.74 lbs. | \$0 05½ |
| 17/16 | 5.5 lbs. | 0 05½ |
| 111/16 | 7.6 lbs. | 0 05 |
| 115/16 | 10. lbs. | 0 05 |

BELTING.

| | Per foot. |
|---------------------|-----------|
| 1 inch | \$0 14 |
| 1¼ inches | 0 19 |
| 1½ inches | 0 24 |
| 1¾ inches | 0 29 |
| 2 inches | 0 34 |
| 2¼ inches | 0 39 |
| 2½ inches | 0 43 |
| 2¾ inches | 0 48 |
| 3 inches | 0 53 |
| 3¼ inches | 0 58 |
| 3½ inches | 0 63 |
| 3¾ inches | 0 67 |
| 4 inches | 0 72 |
| 4½ inches | 0 82 |
| 5 inches | 0 91 |
| 6 inches | 1 11 |

CONE PULLEYS.

The sum of the prices of all sizes of pulleys comprising a cone constitutes the list price of such cone.

COLLARS.

| | | | |
|-----------------|--------|------------------|--------|
| 1¾/16 | \$0 80 | 111/16 | \$1 20 |
| 17/16 | 1 00 | 115/16 | 1 40 |

TRIBUNE NEWSPAPER FOLDER.

All Iron Frame.
Working Parts Steel and Iron.
All Movements Positive.
No Sprocket Chains.
No Lost Motion.

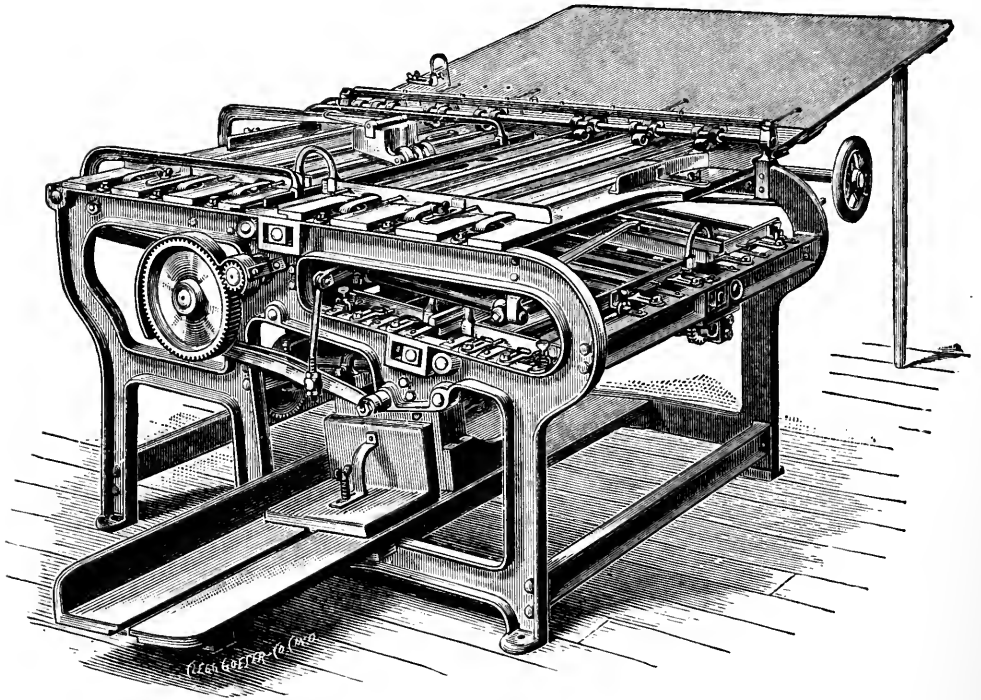

This is a folder of the highest grade of construction and efficiency, without a superior for its purpose on the market, and sold at such moderate net prices as to make so-called "cheap" folders highly expensive in comparison—durability and reliability considered. It has no makeshift devices. It folds on the same principle as the high-grade book machines. The simplest folder made.

Made in one size only, 36×48 inches, which takes in any size sheet, whether folio or quarto, from 22×32 to 36×48 inches.

Paster and trimmer can be furnished at time of purchase or added afterward.

Made with three- and four-fold deliveries. Three-fold work is delivered in a receiving box, while four-fold work is delivered in a packer, as shown in illustration.

In the hands of a competent operator it will fold ordinary sixteen- and thirty-two-page work.

* Weight, about 900 pounds. Power required, about one-tenth of one-horse power. Speed, 3000 folio or quarto sheets per hour.

LIST PRICES.

| | |
|--|-------------|
| For hand feed | \$400 00 |
| Paster and trimmer (no extra charge for this when insetting or covering attachment is ordered) | 25 00 |
| Fixtures for attaching to press, net | 50 00 extra |

TRIBUNE NEWSPAPER FOLDER.

LIST PRICES—Continued.

- Insetting attachment** inserts a two-page or four-page sheet or supplement between the fourth and fifth pages of a publication, folding either ten or twelve pages and pasting and trimming the entire publication.
 Net \$100 00 extra.
- Covering attachment** outsets two pages upon eight pages, making a ten-page publication; or outsets a four-page cover or supplement upon eight pages, making a twelve-page publication. It pastes and trims.
 Net 100 00 extra.

The net price of this thoroughly reliable and durable Folder is very little more than asked for inferior affairs which in the end will prove to be most expensive and least satisfactory. This Folder is made to do perfect work for many years.

UNIQUE IRON-FRAME FOLDER.

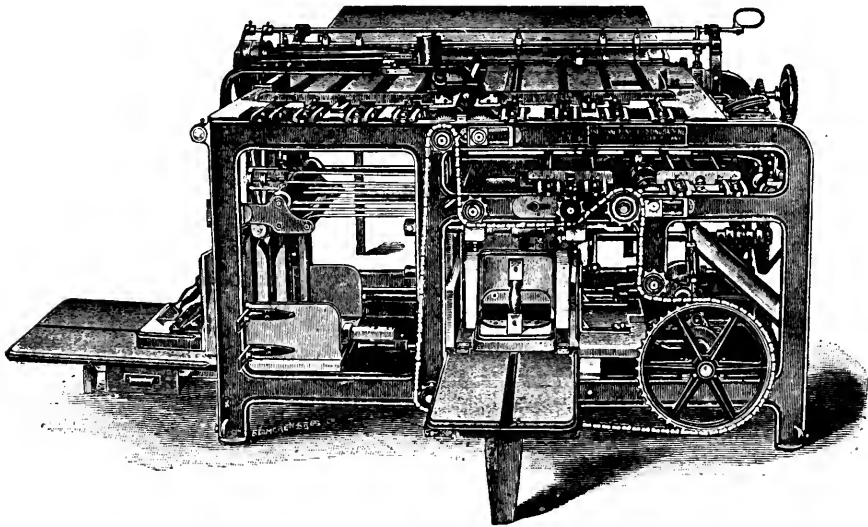

Built by the maker of the Bennett Economical Folder, shown on following page, to overcome the objections to wood-frame folders.

For hand-feed or attachable to any back-delivery cylinder press.

- | | |
|---|----------|
| To fold sheet 32×44 inches, three- and four-fold, with paster and trimmer for eight-page work | \$300 00 |
| To fold sheet 36×50 inches, three- and four-fold, with paster and trimmer for eight-page work | 300 00 |
| Folio inserting attachment | 60 00 |
| Quarto inserting attachment | 100 00 |
| Folio and quarto inserting attachment, combined | 125 00 |
| Quarto covering attachment | 100 00 |
| Fifth or post-office fold | 75 00 |
| Hand feed and attachable in one machine | 50 00 |
| Attachments for front-delivery press | 25 00 |

Floor space of 32 × 44-inch folder is 40 × 56 inches; of 36 × 50-inch folder, 46 × 62 inches.

BENNETT ECONOMICAL FOLDER.

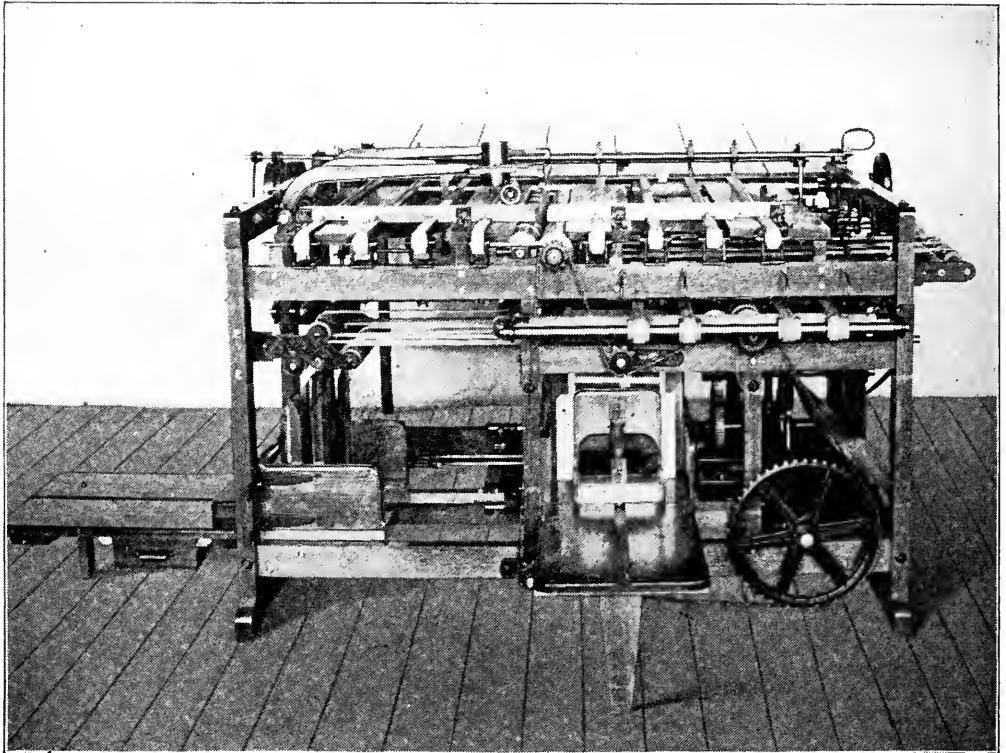

Has a strong, wooden frame, with working parts of iron. Delivers at third and fourth folds, and can be changed without stopping machine. Has pasting and trimming attachment for eight (8) page work. Built in hand-feed, or attachable to any cylinder press, front or back delivery. All journals are of tool steel, with journal boxes three diameters long, hung in self-adjusting pivot hangers, making it possible to remove any fold roll, driving or rock shaft in a few moments and replace in line, and there is not a gear on the machine but can be reached conveniently and removed easily. All adjustments are made by screw, each tape tightened independently, and drop of fold blades can be regulated by the "turnbuckle" adjustment to one-hundredth of an inch. There are side guides to insure accuracy in folding, whether a sheet comes from a press or feed-board.

No extra charge for press fixtures in attachable machines, except for front-delivery press.

LIST PRICES.

| | |
|---|----------|
| 32×44 (6-column quarto), or 36×50 (7-column quarto), including paster and trimmer | \$240 00 |
| Folio supplement attachment, with paster | 50 00 |
| Quarto supplement attachment, with paster | 85 00 |
| Folio and quarto supplement attachment, combined | 125 00 |
| Cover attachment for eight pages | 100 00 |
| Fifth or post-office fold | 50 00 |
| Hand-feed and attachable in one machine | 50 00 |
| Attachments for front-delivery press | 25 00 |

THE BENNETT COUNTRY QUARTO FOLDER.

This machine is exactly the same as the Economical Folder, except that, instead of regular packing boxes at the third or fourth fold, it has a packing box at the fourth fold and a drop box at the third fold.

| | |
|--|----------|
| 6 or 7-column quarto, including paster and trimmer | \$200 00 |
|--|----------|

Hand-feed or attachable to press.

GALLEY PROOF PRESSES.

AMERICAN PROOF PRESS.

Built in the most substantial manner, thoroughly braced, with accurate bed and cylinder. The cylinder is much heavier than on the average proof press, and consequently gives a much better impression. The best proof press made.

With Iron Stand.

- No. 1, 10×31 inches inside \$30 00
- No. 2, 16×31 inches inside 42 00

Without Stand.

- No. 1A, 10×31 inches inside . . . \$22 50
- No. 2A, 16×31 inches inside . . . 30 00

Each proof press is furnished with blanket, brayer frame and stock.



American Proof Press.

CHALLENGE PROOF PRESS.

The circumference of the cylinder is the same measurement as the printing surface of the bed, the cylinder revolving once from stop to stop. The No. 1 cylinder weighs 85 lbs.; other cylinders of proportionate weights. The cylinder is covered with finest quality felt blanket, and a brayer is furnished with each press, excepting those without iron stand. Nos. 1 and 2 have shelf for paper underneath the cabinet.

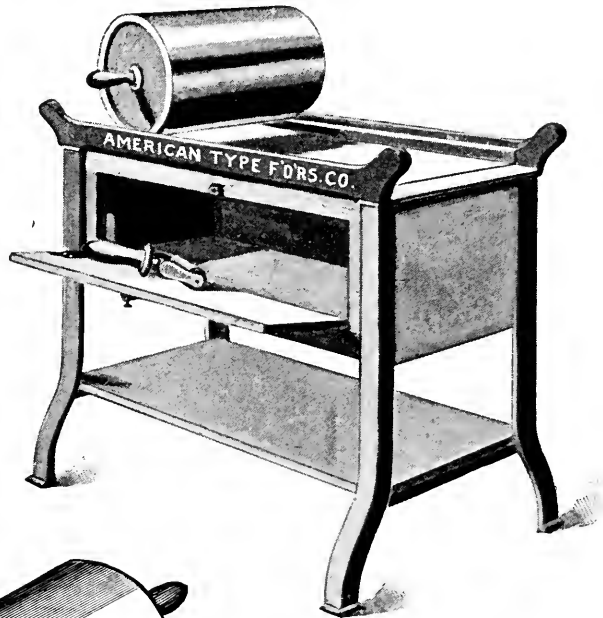

No. 1 Challenge Proof Press.

| Size. | Inches. | Price. |
|---------|-------------------------------|---------|
| No. 0, | 9 × 27, with iron stand . . | \$25 00 |
| No. 1, | 10¼ × 32, with iron stand . . | 30 00 |
| No. 2, | 16½ × 35, with iron stand . . | 40 00 |
| No. 00, | 9 × 27, without iron stand, | 15 00 |
| No. 01, | 10¼ × 32, without iron stand, | 20 00 |
| No. 02, | 16½ × 35, without iron stand, | 30 00 |

ECONOMIC PROOF PRESS.

This is the cheapest proof press made. It has no bed, but consists of a roller and braced side frame.

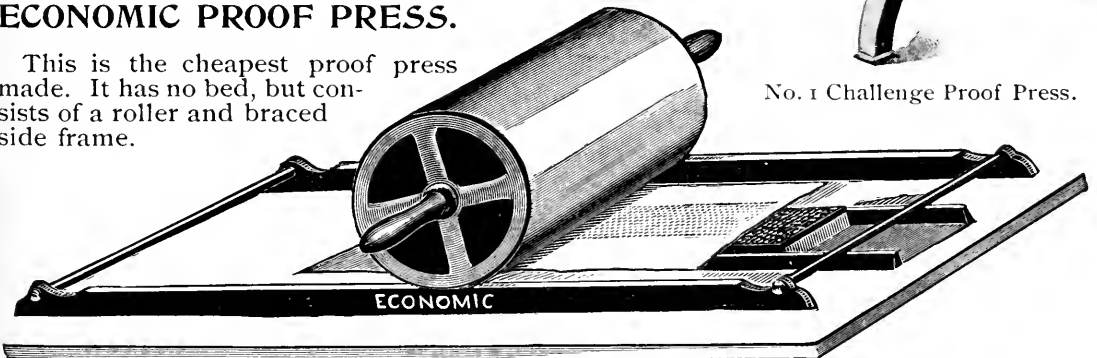

ECONOMIC

10×34 inches inside, complete with blanket and weight mould \$13 50

A mould is provided for casting weights which can be placed inside the cylinder to increase pressure according to character of the work.

FELT BLANKETS FOR PROOF PRESSES.

See page 1070 for prices of Felt Blankets.

WEB SUCCESS SELF-INKING PROOF PRESS.

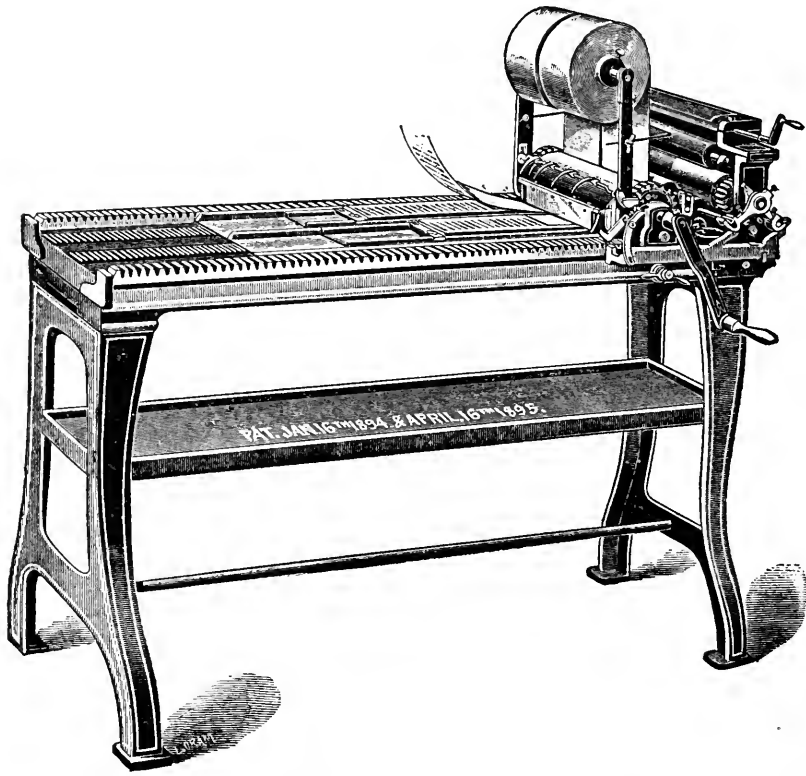

This press is self-feeding and self-inking. The 12-inch and wider presses will hold one or two webs of paper and prove two galleys or forms simultaneously. In addition to a great saving of time, there is a saving in paper, as the length of the proof sheet is adjusted automatically to the length of the matter to be proved—if the take is short, the paper used is correspondingly short. The printing cylinder is of iron covered with vulcanized rubber, giving a perfect impression. The impression is adjustable, as on any cylinder press. There are two form rollers, and a ductor roller which conveys the ink from ink fountain to the inking cylinder. These presses are easy to operate, and in the larger printing establishments are economical, one of them doing the work of four ordinary galley proof presses and doing it better. They are in use by the majority of the leading newspapers throughout the world.

PRICE LIST.

| | |
|-----------------------------------|----------|
| 10-inch bed, single web | \$300 00 |
| 12-inch bed, single web | 325 00 |
| 12-inch bed, double web | 350 00 |
| 18-inch bed, single web | 375 00 |
| 18-inch bed, double web | 400 00 |
| 24-inch bed, single web | 475 00 |
| 24-inch bed, double web | 500 00 |

MAILING SUCCESS PROOF PRESS.

Used by the "Ladies' Home Journal," and Similar Publications.

| | |
|---|----------|
| 15-inch bed, to take six 30-inch mailing galleys; mounted on castors, with feed-board | \$450 00 |
|---|----------|

HERALD-SUCCESS SELF-INKING PROOF PRESS.



Similar in principle to the web proof press described on opposite page, except that the paper is either laid on the form or fed from a feed-board. The illustration shows press with feed-board, although many are sold without feed-board. This press is designed for use in job offices, in the mailing departments of papers of large circulation, for proving full pages of newspapers, etc. It prints beautifully, bringing out half-tone illustrations clearly in all details. These presses are in use in the best printing offices of the world. List of users, with descriptive circular, sent on application.

PRICE LIST.

| | |
|---------------------------|----------|
| 10-inch bed | \$250 00 |
| With feed-board | 300 00 |
| 12-inch bed | 275 00 |
| With feed-board | 335 00 |
| 18-inch bed | 300 00 |
| With feed-board | 375 00 |
| 24-inch bed | 400 00 |
| With feed-board | 490 00 |

IDEAL HAND CYLINDER PRESS.

The type form on this press is stationary. The cylinder is moved over the tympan by link belts running over sprocket wheels at each end of the press, and it prints a sheet at each forward or backward movement. The cylinder is made of steel, and is held firmly to the tracks by truck-wheels which run in a groove on the under side of the tracks. The boxes which hold the cylinder at each end, and in which it revolves, are connected by a stretcher rod running above the cylinder, which prevents side friction. The impression is regulated by four screws—two on each side—which raise or depress the bearers on which the cylinder runs. An effective inking apparatus is supplied, but is extra. A number of Ideal Presses are in use, and intending purchasers may gather how satisfactory they are to the users by reading the following extracts from a great many commendatory letters received:

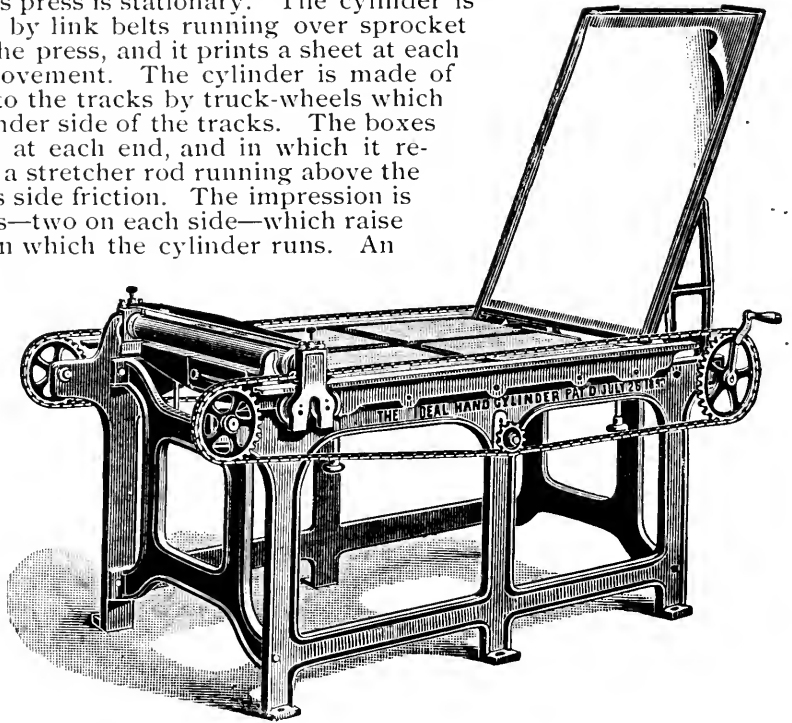

“My wife ran off 300 an hour on it the first day it was put up.” *** “With it our inexperienced pressman has made the following speed: 750 impressions in 75 minutes; 475 in one hour; 100 in 11 minutes. We run a regular lick of 100 every 15 minutes, or 400 per hour.” *** “The press is so simple that the veriest novice can set it up, and so light-running that a boy may operate it with ease.” *** “It is far superior to my old Washington for speed and quality of work.”

- No. 1. 8-column folio or 5-column quarto, size of bed, 28½×43 inches \$200 00
 - No. 2. 9-column folio or 6-column quarto, size of bed, 33¾×48¼ inches 225 00
 - No. 1. Floor space, 31×55. Weight, 700 pounds. Shipping weight, 975 pounds.
 - No. 2. Floor space, 35×60. Weight, 800 pounds. Shipping weight, 1100 pounds.
- Frisket for either size, furnished to order only, \$6 00. Extra tympan, covered, for either size, \$7 00.

IDEAL INKING APPARATUS.

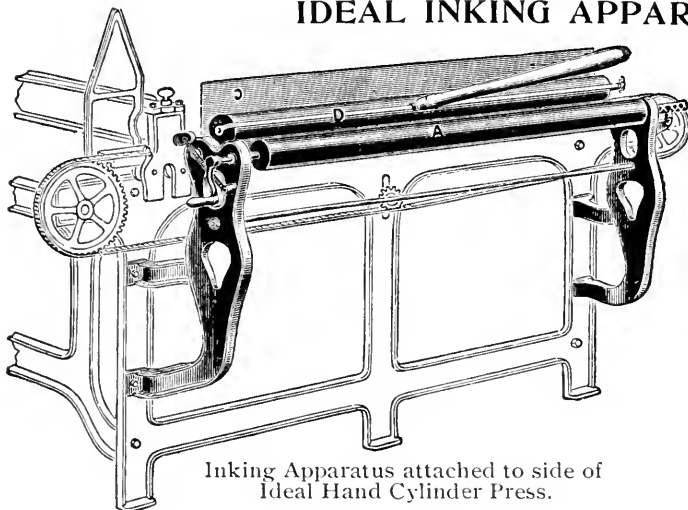

There are two inking cylinders (A and B), one of which (A) revolves by means of the hand crank, and while revolving it automatically vibrates. The inking roller (D) rests on the inking cylinders and receives its supply of distributed ink. When the roller (D) is pushed toward the form, the automatic sheet-steel drop-leaf ink table (C) descends on the bed of the press and the roller (D) passes easily on to the type form. When the roller returns, the ink table (C) resumes its perpendicular position automatically. The Ideal Inking Apparatus is not furnished with the Ideal Press unless specially ordered.

- No. 1, for 8-column folio or 5-column quarto . \$30 00
- No. 2, for 9-column folio or 6-column quarto . 32 00

Hand Roller with Two Handles, including Extra Core :

- No. 1. 20 inches long, for 8-column single page \$3 75
- No. 2. 22 inches long, for 9-column single page 4 25

WASHINGTON
HAND
PRESS.

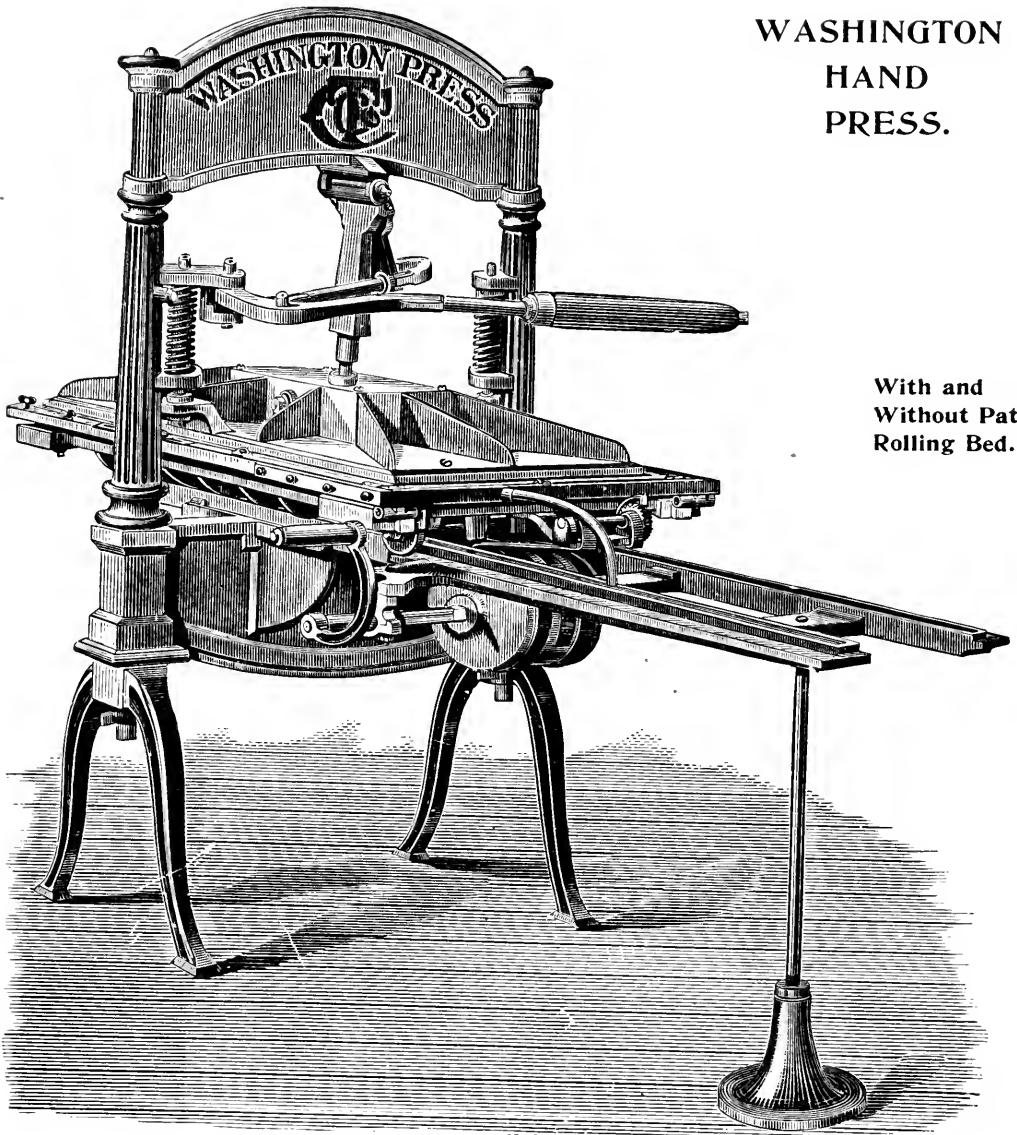

With and
Without Patent
Rolling Bed.

Washington Hand Press with Patent Rolling Bed. Built solely by American Type Founders Co.

| Platen. | Bed. | | |
|------------------|---|--|----------|
| 14×18 inches . . | 17 ×21 inches | | \$150 00 |
| 16×21 inches . . | 20 ×25 inches | | 175 00 |
| 20×25 inches . . | 24 ×29 inches | | 200 00 |
| 23×31 inches . . | 25¾ ×34¾ inches, for 6-column folio | | 200 00 |
| 23×35 inches . . | 26½ ×39 inches, for 7-column folio | | 225 00 |
| 25×39 inches . . | 28½ ×42 inches, for 8-column folio or 5-column quarto | | 250 00 |
| 27×43 inches . . | 31½ ×47½ inches, for 9-column folio | | 275 00 |

WITH PATENT ROLLING BED.

The patent rolling bed runs on rollers instead of sliding, and thus much exertion is spared the pressman, and the work is done quicker.

| Platen. | Bed. | | |
|------------------|--|--|----------|
| 23×35 inches . . | 26½ ×39½ inches, for 7-column folio | | \$250 00 |
| 25×39 inches . . | 28½ ×43½ inches, for 8-column folio or 5-column quarto | | 275 00 |
| 27×43 inches . . | 31½ ×47½ inches, for 9-column folio | | 300 00 |
| 29×43 inches . . | 33 ×48 inches, for 6-column quarto | | 325 00 |

Above prices include two pairs of points, one wrench, one sheepsfoot, pair of bearers, and one extra frisket.

As a rule we can supply second-hand Washington Hand Presses of all sizes on demand.

THE AMERICAN JOB PRESS COUNTER.

For Platen Presses.

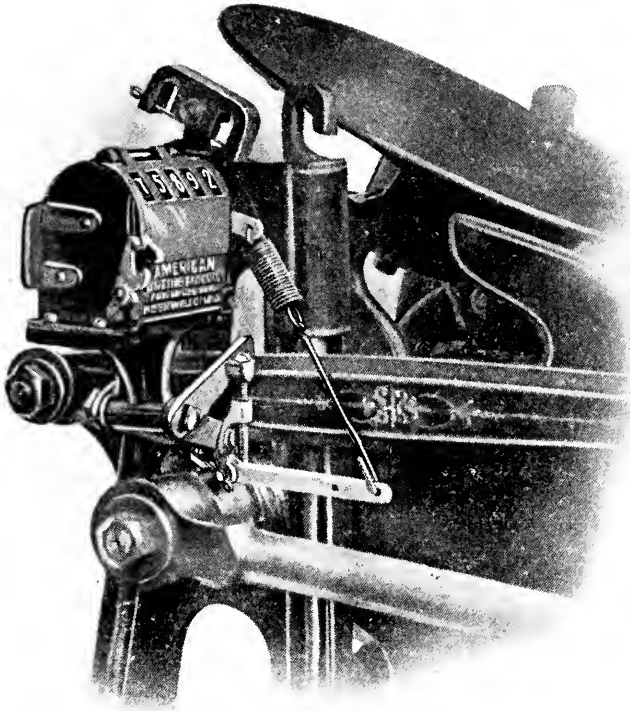

The above cut shows Counter attached to an 8x12 Chandler & Price Gordon.

We place this counter on the market after testing its merits thoroughly and believing that the printer will appreciate a reliable counter with which he can keep an accurate record of the number of impressions on his job presses. The counter registers *only when the impression is on.*

There is absolutely no strain whatever on the counter or attachment, the movement being positive and easy, and when once it is set needs no further attention. It can be attached to almost any Gordon press. Give size and make of press when ordering.

Any number wheel can be set forward or backward without disturbing the others.

There are no screws used in the entire construction, and the parts are so put together that they cannot get out of order or become disarranged while in use.

The pawls or dogs are so made that there are no corners to wear off and make the counting uncertain.

Price \$12 00

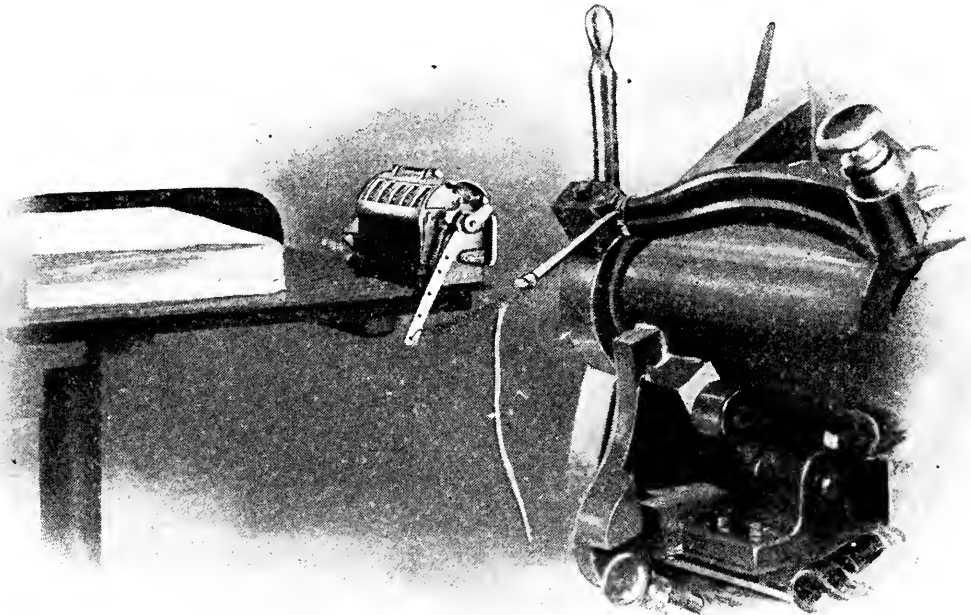

The above cut shows Counter fastened on left feed table of Gally Universal Press.

Price \$10 00

AMERICAN COUNTING MACHINE.

Has no superior for strength, accuracy, reliability. Can be set to zero, or any number, with the fingers with the greatest ease. There are no springs inside this counter, and all movements of the figure-dials are so positive that it is impossible for them to miss registering. The case may be screwed to the wall or on a table, and the lever can be set to any position, and will work from front or back. The figures are cast solid, nickel-plated, and are very legible.

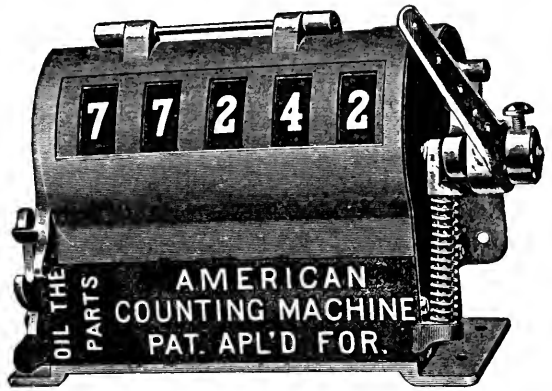

Price \$10 00

See illustration of this Counter attached to a C. & P. Gordon and a Universal Press on opposite page.

DURANT COUNTER.

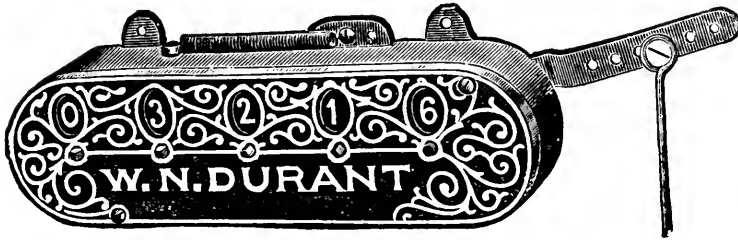

This counter gives perfect satisfaction. It is as reliable as it is strong, durable, and attractive.

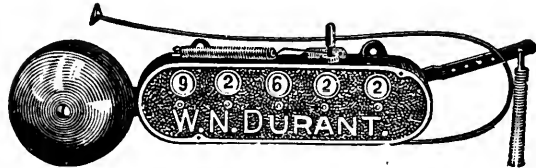

No. 2, with Alarm Gong.

- No. 1, 4-dial, counts 10,000 . . . \$ 8 00
- No. 2, 5-dial, counts 100,000 . . . 10 00
- No. 3, 6-dial, counts 1,000,000 . . . 12 00
- No. 2A, 5-dial, with 4-inch gong, to give alarm at each 100 15 00

DOUBLE DIAL ALARM COUNTER.

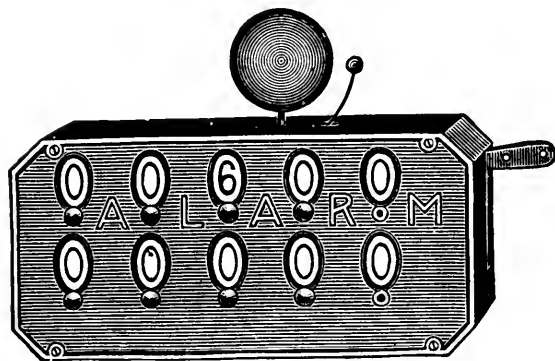

This counter is so constructed that the lower dials show the number run like the usual counter. The upper dials are the alarm device, and can be set (instantly without taking from the case, by thumb-screw or key) to any desired number you wish to print, and when that number is printed the bell will ring. To illustrate: Set the alarm on 600, if that is the number you wish to run, with lower dials on ciphers. First revolution of the machine the lower dials will show 1, and the upper dials 599 or one less, and so on until 600 is run, when the upper dials will stand at (000) ciphers and the bell will ring. Any time you look at the counter

it will show how many yet to run. Perfectly simple in construction. No more springs are used than in an ordinary counter, and all are made of best piano wire. This counter has an iron case, and very legible figures.

No. 1. Double Dial Alarm, 5x8, 1/2-inch figures, registering 100,000 \$15 00

WETTER NUMBERING MACHINES.

THE BETTER WETTER.

The latest successful development in Numbering Machines, for use with or without type on printing presses. This is the only typographic numberer that prints nothing but the figures, without "No.," a period, or any other affix or suffix intended to act as plungers or to prevent the printed sheet from being smeared by the revolving figures. The pressure of the platen or cylinder on the figures operates the mechanism which changes the numbers and also an ingenious bearer, which raises automatically and holds the printed sheet off the figures while they are changing. This bearer does not print on or indent the paper.

The Better Wetter is made with that perfection in construction and materials which have made all "Wetter" Machines famous.

This is the smallest machine of its kind, being 7/8-inch wide, the length depending upon the number and thickness of figures required. *Type can be set close up to the machine on all sides.*

Four regular styles of figures made. Styles J and K kept in stock. Styles L and M furnished at short notice.

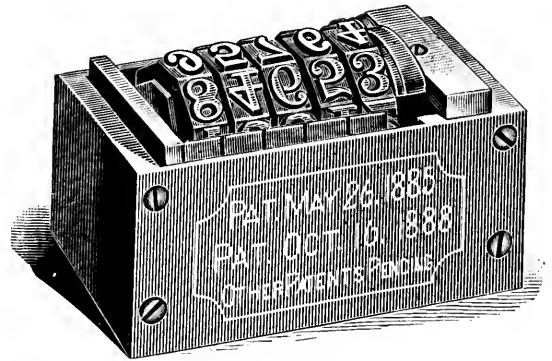

The Better Wetter.

Style J 1234567890 Style K 1234567890

These Styles used on both the Better Wetter and No. 1 Wetter.

Style L 1234567890 Style M 1234567890

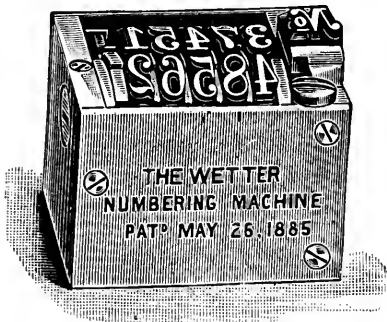

No. 1, actual size, Style J.

No. 1 WETTER NUMBERING MACHINE.

This is the regular machine, of which thousands are in use all over the world. Permits printing and numbering at one impression. Can be used on any make of press. Numbers automatically from the unit to its full numerical capacity. It can be used with or *without* the character "No." Other characters, such as a star, parenthesis, fist, cipher, or any letter, can be used to either precede or follow the figures. Produces clean, smooth and distinct figures. Styles of figures J and K are most used, and are kept in stock, but Styles L and M can be furnished upon short notice.

The 5-wheel style J machine occupies a surface space of 7/8-inch in width by 1 1/4 inches in length.

PRICES OF No. 1 WETTER AND THE BETTER WETTER.

| | |
|---|---------|
| Style J or K or L or M, five wheels, numbering up to 99999 | \$25 00 |
| Style J or K or L or M, six wheels, numbering up to 999999 | 28 00 |
| Style J or K or L or M, seven wheels, numbering up to 9999999 | 31 00 |

In ordering state which machine is required, and state style of figure and number of wheels desired. Unless otherwise ordered, the 5-wheel style J Better Wetter will be sent.

SPECIAL WETTER NUMBERING MACHINES.

See description and prices on opposite page.

Made to Order only.

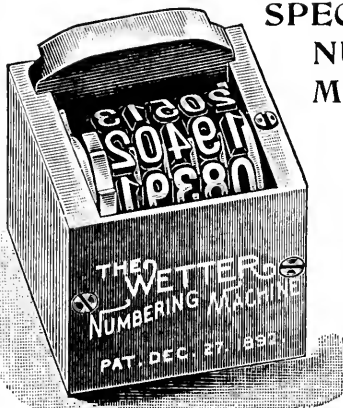

No. 3.

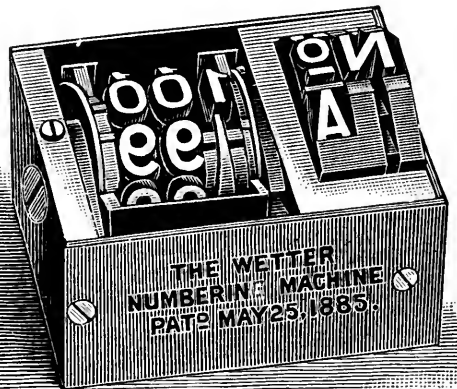

No. 4.

No. 3. WETTER MACHINE FOR SMALL RAILROAD WORK.

(See illustration on opposite page.)

Numbers on extreme end, as shown on diagram. Plunger is at foot of machine, and does not strike the printed sheet. Occupies only 3/8-inch space on ticket when locked in form.

1234567890

Style of Figures for No. 3 Machine.



| | | |
|--------|--------------------------------------|---------|
| No. 3. | 5-wheel (figures as above) | \$25 00 |
| No. 3. | 6-wheel | 28 00 |
| No. 3. | 7-wheel | 31 00 |

No. 4. WETTER MACHINE FOR NUMBERING CASH SALE SLIPS.

(See illustration on opposite page.)

Made to number automatically from 100 to 1, or 50 to 1. Object of numbers running backward is to avoid expense of collating sheets after printing. Can be made to number forward. After printing to 100 or 50 they commence again at 1. Plunger wheel can be made with a letter wheel to print A, B, C, D, E, F, G and H, or letter slides may be used in plunger, and any of these letters or the character "No." can be used at will by turning the wheel until the desired letter is on top.

Price, 3-wheel, with letter wheel \$25 00

No. 5. WETTER DUPLEX MACHINE FOR NUMBERING DUPLEX RAILROAD TICKETS.

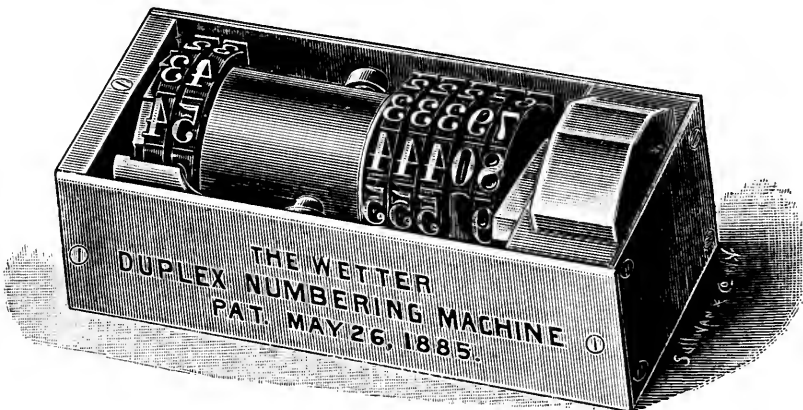

Numbers tickets on both sides and also on stub at one impression. Ticket numbers generally run from 1 to 100 or 0 to 99, and changes consecutively the book number which runs from 1 to 9999 or 1 to 99999. Can be arranged to change once at every one hundred impressions of ticket number, or can be made stationary, so that changes can be made by hand. There are three machines to a set—one for stub and one for each side of the ticket, to be used in same manner as ordinary Wetter Numerer, needing no attachment of any kind.

Set of three machines, net \$120 00

No. 7. WETTER MACHINE FOR NUMBERING BOND COUPONS.

Numbers with or without serial attachment. 7/8-inch wide, and can be used on narrowest bond coupons. Letter wheel can be placed on end to indicate serial No. A, B, C, D, E, F, G, H, I or J; or the serial letter or character "No." can be placed close to figure, thus—A1.

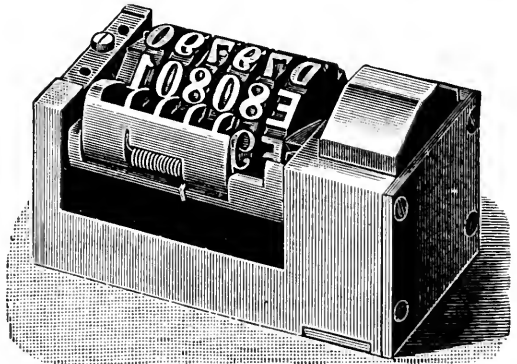

| | |
|--------------------------|---------|
| Price, 5-wheel | \$25 00 |
| Price, 6-wheel | 28 00 |
| Price, 7-wheel | 31 00 |

Continued on following pages.

No. 8. WETTER MACHINE FOR NUMBERING LOTTERY TICKETS.



These are considerably more than type high, and the printing-press bed must be sunk or cut out so it will take in a thickness of two inches. We can supply presses for this purpose. Denominations of the figures can be spelled out under and over the figures in any language. Parenthesis marks can be placed at each side of a figure, thus—(1) to (9). At changing to 10 the parenthesis is moved back one step, and may be changed to include all figures until the full number (99999) is printed. Prices on application. Send full details and samples of work required. We show example of the figures used.

SIX SEVEN EIGHT NINE CIPHER
(67890)
 SEIS SIETE OCHO NUEVE CERO

No. 9. WETTER MACHINE FOR PRINTING NUMBER AND DATE SIMULTANEOUSLY.

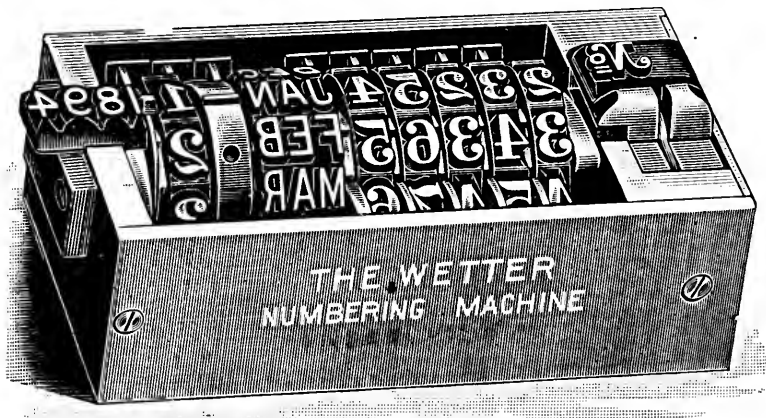

Designed for printing tickets, envelopes, or documents requiring both date and number, such as church envelopes, thus—
 same as the regular Wetter with month wheel, date
25098 JAN 23-1896
 net Works automatically, Machine. Price, 5-wheel, wheels, and year plates, \$38 00

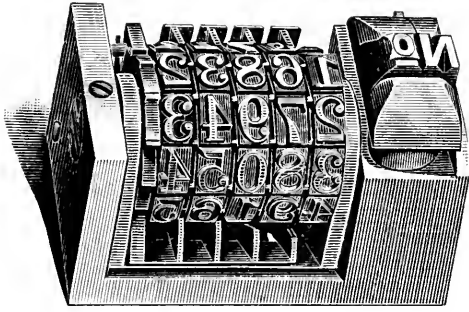

THE IMPROVED WETTER NUMBERING MACHINE.

The Improved Wetter Numbering Machine is just type-high, locks up in any form like a small cut, can be used on any job or cylinder press; prints clean, sharply-defined figures without any perceptible wear, is small and compact enough to allow type matter to be set close to the figures, and it will number anything from 1 up to as high as you wish to number with accuracy and precision. All parts interchangeable.

Styles J and K, five-wheels \$15 00
 Styles J and K, six-wheels 18 00

MONITOR PAGING AND NUMBERING MACHINE.

For Treadle or Steam Power.

STYLES OF FIGURES.

There are 27 styles of figures made for this machine. We furnish any style desired or cut to order.

E
5 7 6 3 4 8

I
4 8 2 5

K
3 5 7 4

Q
2 5 8 6 4 3



O
3 2 4 5 1 0

W
2 5 3 7 6 0

The new-pattern Monitor Numbering and Paging Machine.

This machine excels all others in quality, durability and simplicity, and particularly in the construction of the heads. They are dust-proof and ink-proof. The arbor has twice the bearing surface, insuring perfect register and twice the durability. The impression on one sheet or 1/2-inch thickness is the same. Can be changed by a single hand-screw to number 2, 4, 6, 8, 10, or 1, 3, 5, 7, 9, or consecutively or repeatedly. The table is adjustable. Power attachments can be added any time to foot-power machines. Power attachment is operated by an eccentric, thereby producing an evenness of motion, noiseless and positive.

| | | |
|---|----------|----------------------|
| With one four-roll steel figure-head | \$235 00 | Foot Power. \$185 00 |
| With one six-roll steel figure-head | 245 00 | 195 00 |
| With one four-roll and one six-roll steel figure-head | 300 00 | 250 00 |
| Steam attachment on foot-power machine, extra | | 50 00 |
| Extra repeater, to repeat as many times as desired | | 3 00 |

STEEL PAGING AND NUMBERING FIGURE-HEADS.

| | |
|---|---------|
| Four-roll, to number 10,000 | \$50 00 |
| Five-roll, to number 100,000 | 60 00 |
| Six-roll, to number 1,000,000 | 70 00 |

Prices of numbering heads include one repeater. Styles of figures sent on application.

BATES AUTOMATIC NUMBERING MACHINES.

These very superior machines operate consecutively, duplicate and repeat, and the changes are made instantaneously by simply moving the pointer on the dial. The figures are cut in steel and print perfectly. The movement of the figures is entirely automatic from 1 to the full numerical capacity of the machine. The figures receive ink automatically from a thick felt pad. The mechanism, material and finish are unsurpassed. Weight about 16 ounces. These machines are all furnished with special retarding device, which absolutely prevents the figures from ever getting out of alignment. Another great feature is that the ciphers are depressible, which makes the wearing even on all parts of these machines. The mechanism of the Bates Automatic Numbering Machine is internal, and it is entirely enclosed, so that it is not liable to get out of order or get clogged by dust. The ink-pad box is so arranged that the ink pad can be easily re-inked without soiling the fingers. The gauge plate is slotted, corresponding with the number of wheels of the machine, so that the exact location of the figures can be absolutely determined.

In lieu of Duplicating movement machines can be supplied with any one of the following movements at same prices: Triplicating, Quadruplicating, Quintuplicating, Sextuplicating, but are not carried in stock, being made to order only.



Bates Machine, one-half actual size.

A 12345 E 12345
 G 12345 F 12345

Styles E and G are kept in stock and A and F are furnished to order at short notice.

| | | | |
|------------------------|-----------|-------|---------|
| 4 wheels, numbering to | 9,999 | | \$12 00 |
| 5 wheels, numbering to | 99,999 | | 14 00 |
| 6 wheels, numbering to | 999,999 | | 16 00 |
| 7 wheels, numbering to | 9,999,999 | | 18 00 |

Prices include ink and pad.

PARAGON NUMBERING MACHINE.

A machine of a cheaper grade, but accomplishing the same work as the Bates, the chief difference in method of construction being in the dial changer. In this machine the changes are made by inserting a pin in the holes opposite the indicators.

| | | | |
|------------------------|-----------|-------|---------|
| 4 wheels, numbering to | 9,999 | | \$ 8 00 |
| 5 wheels, numbering to | 99,999 | | 9 00 |
| 6 wheels, numbering to | 999,999 | | 10 00 |
| 7 wheels, numbering to | 9,999,999 | | 12 00 |

Each machine in wood box, with bottle of ink.

In ordering, state style of figures required. Paragon Machines with Gothic figures can be supplied at same prices.

R 1234567890
 S 1234567890
 T 1234567890
 W 1234567890



INK FOR NUMBERING MACHINES.

| | | | | |
|--------------------------|----------------------|--|--------------------------------|----------------------|
| Ink—No. 0, ½ oz. | 20 cents per bottle. | | Ink—No. 3, 4 oz. | 40 cents per bottle. |
| No. 2, 2 oz. | 25 cents per bottle. | | Extra felts for ink pads . . . | 10 cents each. |

CHANDLER & PRICE PAPER CUTTER.

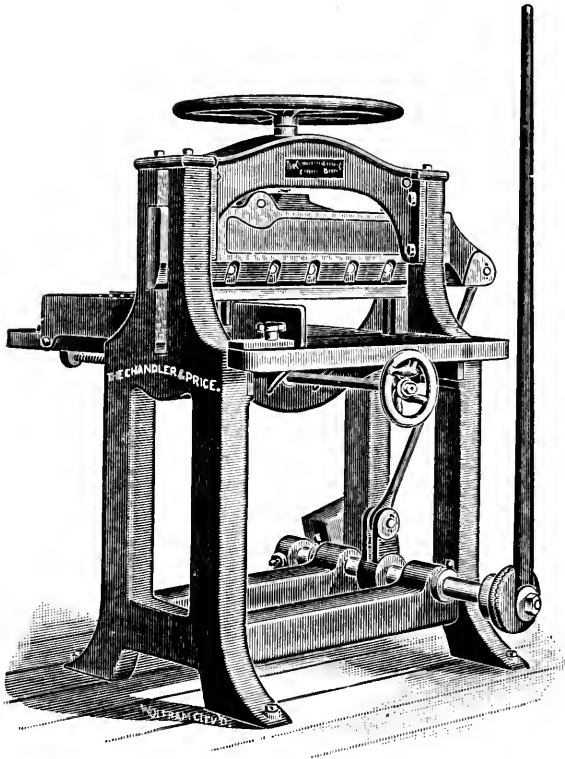

It is built from new designs by scientific methods. It has ample metal, properly distributed to withstand strains. The back gauge and clamp interlock, clamping as narrow as one-half inch. The fingers of the clamp have a broad surface, to avoid creasing the stock. All gauges are accurately squared with the knife. The back gauge extends to within one inch of the side gauge, and is divided and adjustable for book trimming or squaring small work. All parts are strictly interchangeable, and accurately fitting replacements may be ordered by number.

Made by one of the most reliable builders of printing machinery in the world.

| | |
|-------------------|----------|
| 23-inch | \$100 00 |
| 26-inch | 130 00 |
| 30-inch | 175 00 |

CHALLENGE LEVER PAPER CUTTER.

Has set screws and gibs in the frames for taking up wear of knife-bar.

The 25-inch cutter is provided with both front and back stationary side gauges, which are cast on the side frame, and are accurately squared to knife and back gauge. The 30-inch and 32-inch cutters have, in addition to these, an extra side gauge in front, adjustable to either side; also a split back gauge, useful in trimming pamphlets. They are provided with the interlocking back gauge and clamp, for cutting narrow widths, without extra cost.

| | |
|-------------------|----------|
| 25-inch | \$135 00 |
| 30-inch | 200 00 |
| 32-inch | 225 00 |

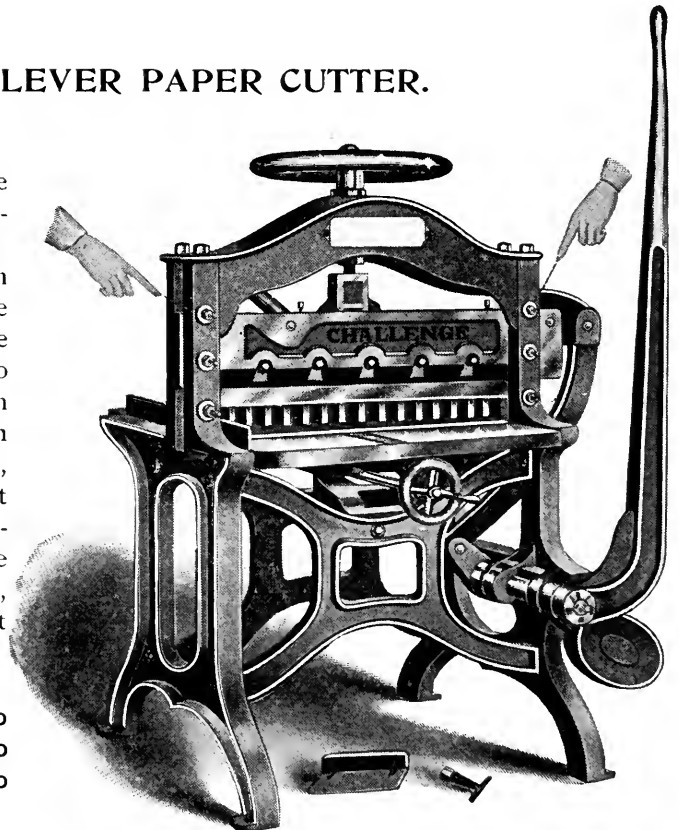

PEERLESS GEM PAPER CUTTERS.

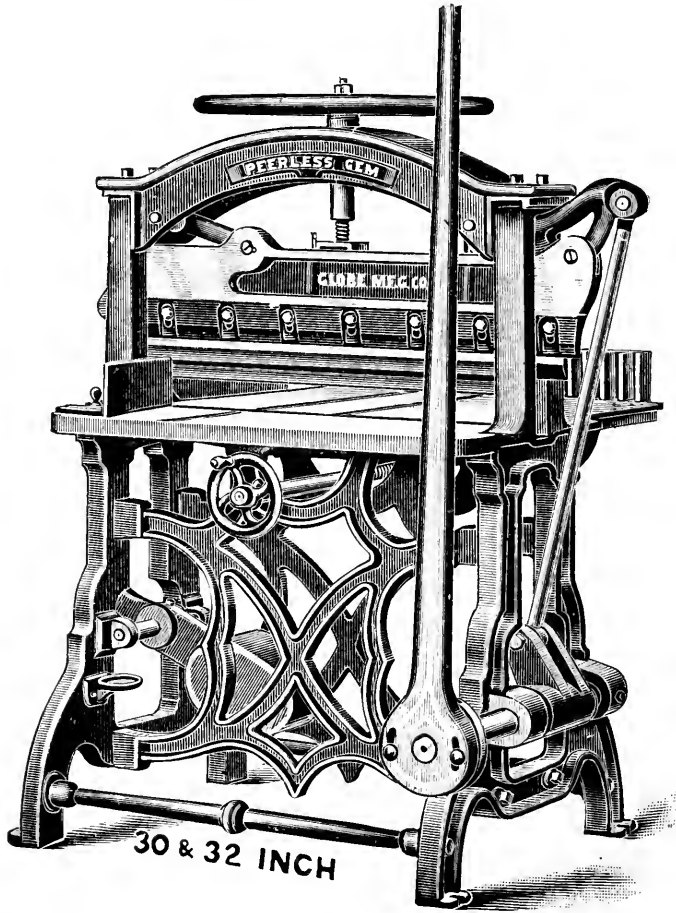

DETAILS OF CONSTRUCTION.

| Weight, Unboxed. | Thickness of Knife Bar. | Thickness of Knife. | Depth of Knife. | Diameter Lever Shaft. | Diameter Steel Lever Connection Shaft. |
|---------------------|-------------------------|---------------------|-----------------|-----------------------|--|
| 30-inch . 1340 lbs. | 1 3/4 in. | 1/2 in. | 5 in. | 2 in. | 1 1/8 in. |
| 32-inch . 1425 lbs. | 1 3/4 in. | 1/2 in. | 5 in. | 2 in. | 1 1/8 in. |

Superior in every detail and in the leverage, cutting with greater ease to operator, and returning from cut with the least possible exertion, owing to their perfect balance. The frame is stronger, heavier and better braced; the knife thicker and deeper, insuring a truer cut and longer life; the lever is adjustable; the balance weight is now hung inside the frame, thus saving floor room. There are split back gauges, side gauges, and a front enameled measuring gauge. Unexcelled in construction, materials used, and finish.

| | |
|-----------------------------|----------|
| 23-inch, cuts 23 1/4 inches | \$100 00 |
| 25-inch, cuts 25 1/4 inches | 125 00 |
| 30-inch, cuts 30 1/4 inches | 175 00 |
| 32-inch, cuts 32 1/4 inches | 200 00 |

Compare details of construction given above with those on other cutters.

25-INCH PEERLESS GEM CUTTER.

Excels all other cutters of its size in weight, ease of cut, strength, durability and finish. It is built on the same design as the Peerless Gem in all points, except that the lever is fixed on the shaft instead of being adjustable. The weight is 825 pounds, unboxed; has $4\frac{1}{2} \times \frac{3}{8}$ -inch knife; $1\frac{3}{4}$ -inch knife bar. The best money's worth ever offered in a 25-inch paper cutter.

The leverage both while cutting and returning is perfect, reducing the exertion of cutting to a minimum.

The balance weight is hung inside the frame to save floor space.

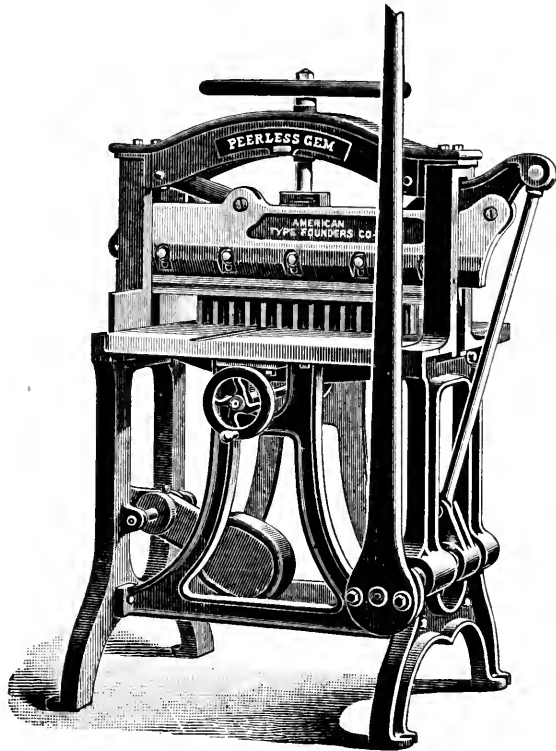

Style of 25-inch Peerless Gem Cutter.

25-inch, cuts $25\frac{1}{4}$ inches \$125 00

23-INCH PEERLESS GEM CUTTER.

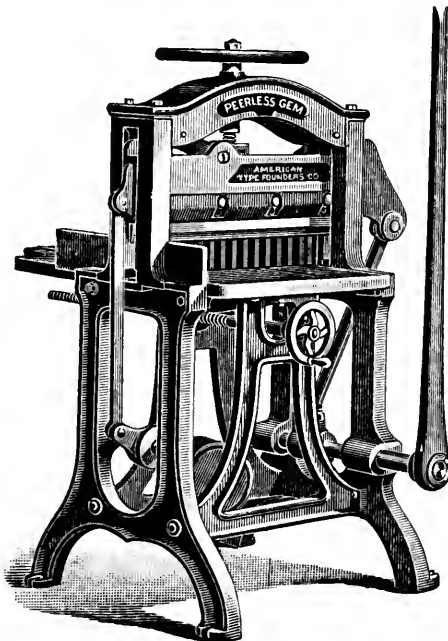

Style of 23-inch Peerless Gem Cutter.

No other cutter of this size, or about this size, equals the new 23-inch cutter. It weighs 725 pounds, unboxed; has $4\frac{1}{2} \times \frac{3}{8}$ -inch knife, and $1\frac{3}{4}$ -inch knife bar. Built on the Peerless-Gem principle, it has leverage of maximum power and easy return, and all the features of the 25-inch Peerless Gem Cutter. It is not possible to build a better cutter for the money asked.

The balance weight is hung inside the frame, thus saving floor space and removing an annoying obstruction.

23-inch, cuts $23\frac{1}{4}$ inches \$100 00

RELIANCE LEVER PAPER CUTTER.

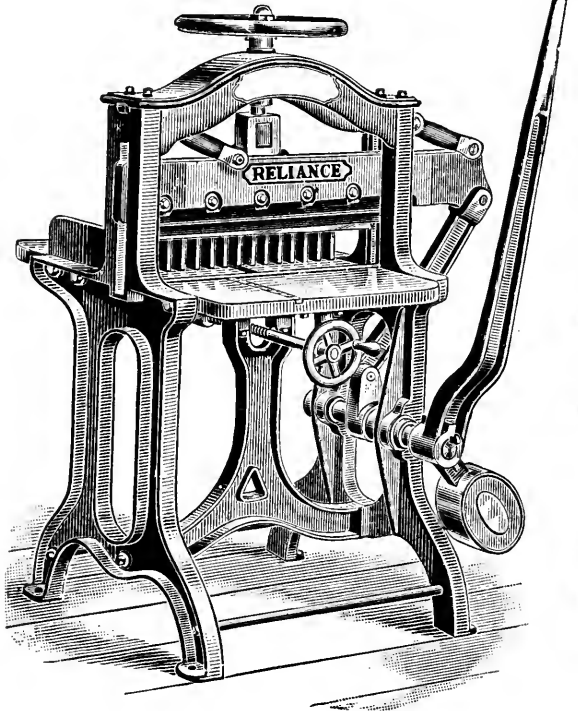

| | |
|-------------------|---------|
| 23-inch | \$90 00 |
| 25-inch | 110 00 |
| 28-inch | 135 00 |

ADVANCE LEVER PAPER CUTTER.

Its special feature is the arrangement for taking up wear in the slideway in which knife bar moves by means of steel gibs controlled by set screws.

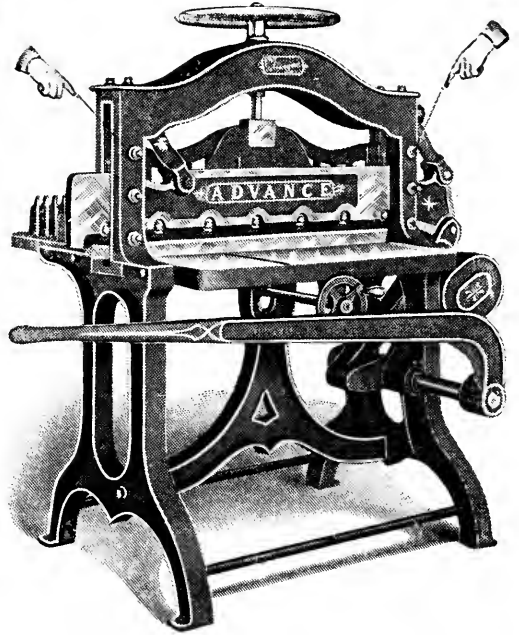

| | |
|--------------------|----------|
| 22½-inch | \$ 90 00 |
| 25-inch | 110 00 |
| 30-inch | 165 00 |
| 33-inch | 200 00 |

CHALLENGE PONY LEVER PAPER CUTTER.

Used in conjunction with larger cutters, small cutters such as these and the cutters shown on page 1009 often double the cutting capacity of an office at a small additional plant expense.

The especial advantage of the 19-inch cutter is that it cuts the usual sizes of flat papers—cap, demy, folio, double cap, medium, and royal.

Prices include interlocking back gauge and clamp, permitting stock to be gauged within one-half inch of knife.

| | |
|-------------------|---------|
| 16-inch | \$50 00 |
| 19-inch | 65 00 |

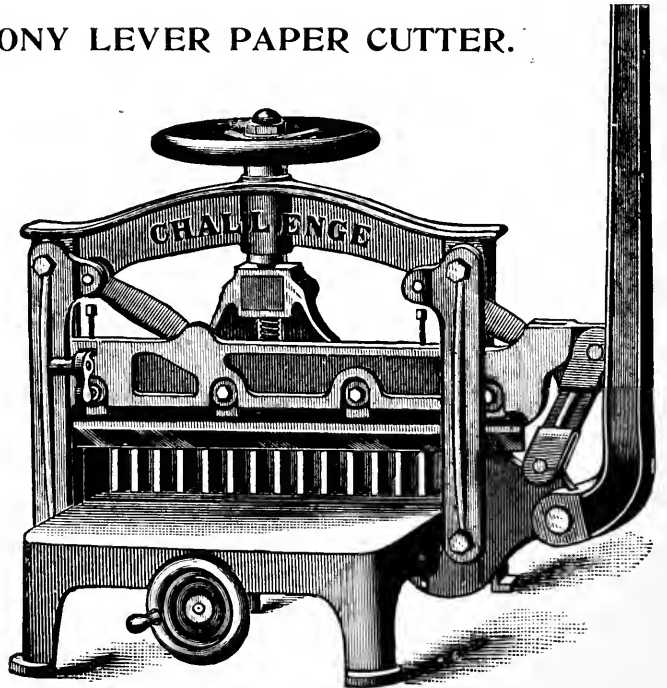

UTILITY PAPER CUTTER.

A thoroughly well-built cutter, without a superior of its size. Has side and back gauges, and a patent reversible clamp which cuts very narrow strips without marking the paper.

| | | |
|----------------------------------|----------------|------------------|
| | Without Stand. | With Iron Stand. |
| Cuts and squares 16 inches . . . | \$50 00 | \$57 00 |
| Cuts and squares 18 inches . . . | 60 00 | 67 00 |

EXTRA KNIVES.

| | |
|-------------------|--------|
| 16-inch | \$4 50 |
| 18-inch | 6 00 |

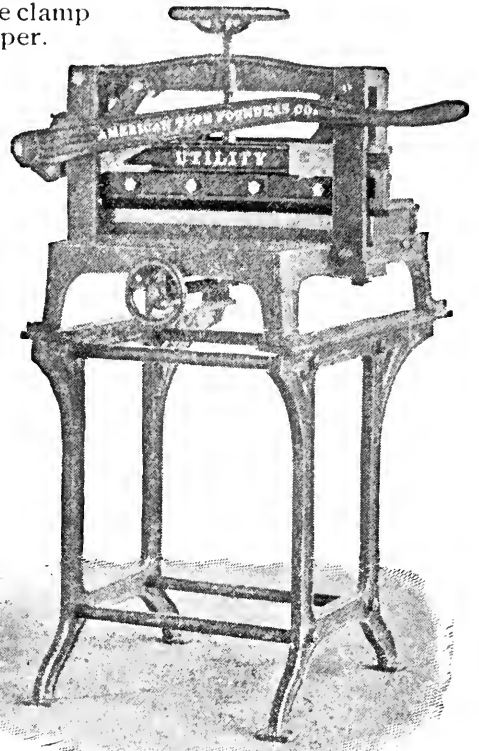

Utility Paper Cutter with Iron Stand.

Iron stands are made for each size, and are recommended where bench room should be saved.

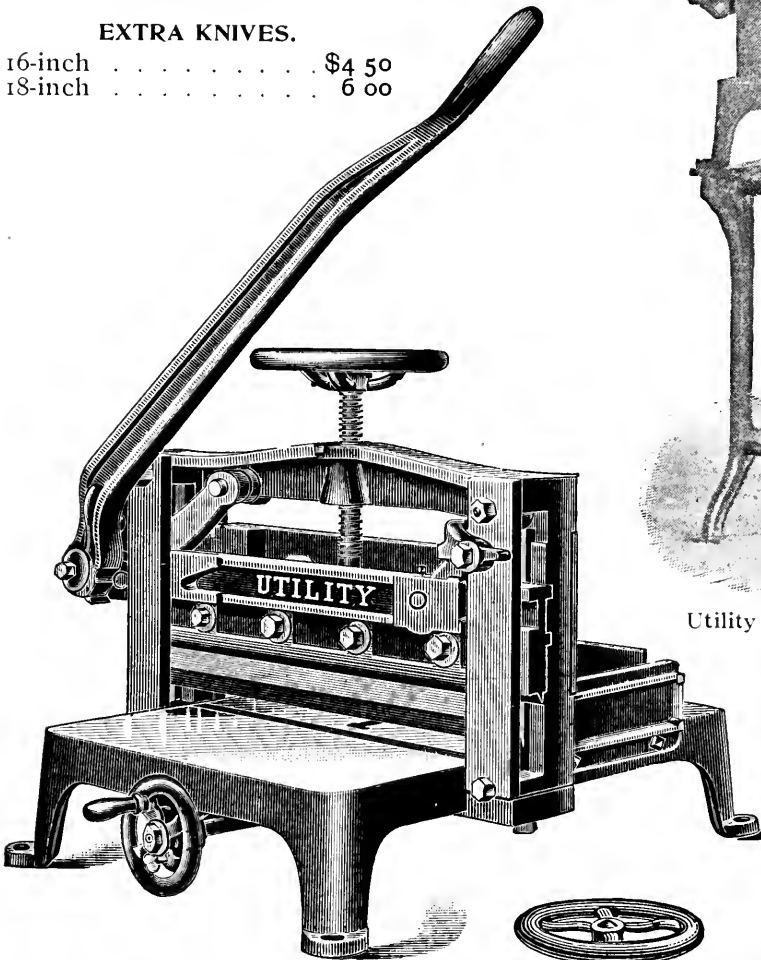

CLIPPER PAPER CUTTER.

Designed for cutting small work, such as labels, circulars, etc. Has a patented reversible clamp, which cuts very narrow strips and leaves no marks on the paper. The lever is pulled forward to cut. Quality of construction is A1.

Cuts and squares 12 inches . . . \$40 00

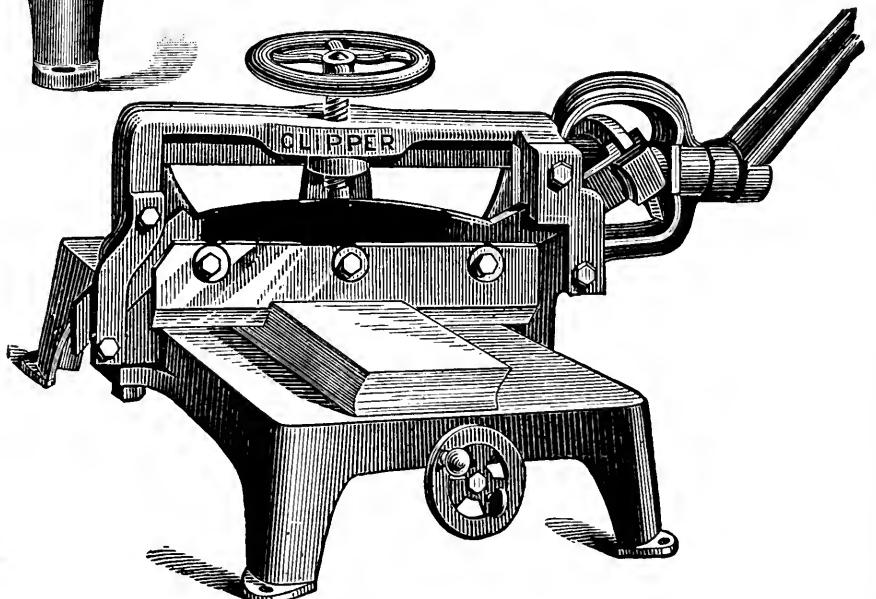

ADVANCE POWER CUTTER.

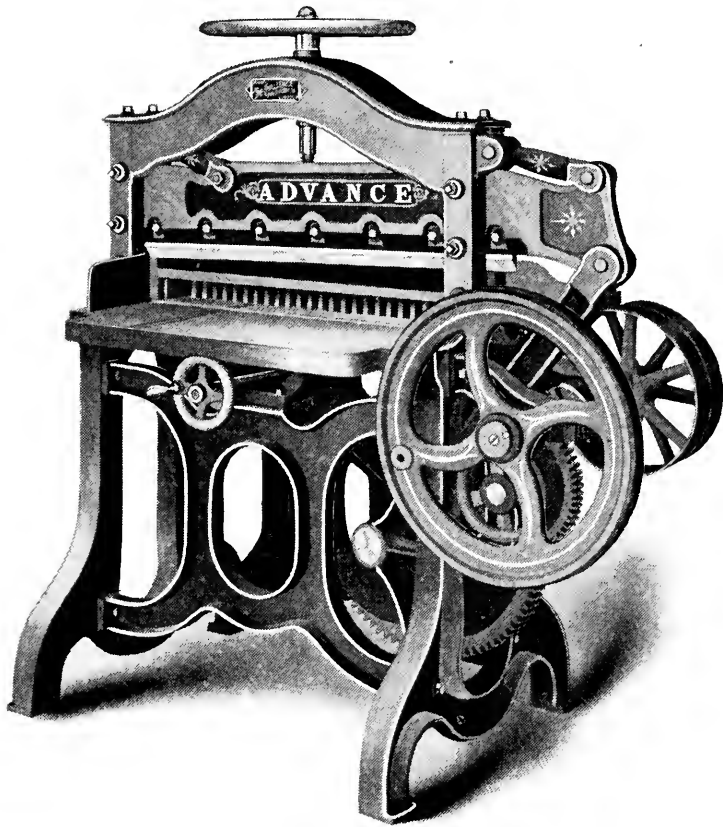

This is the lowest-priced Power Paper Cutter on the market, and can be recommended to buyers with whom low price is a prime consideration.

The Advance Power Cutter is fitted for hand or steam, is solidly built, the frame is firmly stayed by two substantial cross-braces, upon which is bolted the arch that supports the center of the bed, making it perfectly rigid and firm under pressure of clamp or knife.

It is fitted with the interlocking back gauge and clamp, by which paper may be cut to within half an inch of the knife.

It has brass figured rules in bed, back and front.

The throw-off is automatic and stops the knife instantly; it may be thrown off at any point, thus obviating possible waste of paper through error.

The knife has a dip-cut, which will be duly appreciated by all requiring a power paper cutter.

The slideways in which the knife bar moves is faced with steel gibs secured and adjusted by means of three set-screws on each side, so that any wear in the slideways may be taken up quite easily.

This is a very convenient style of cutter, as it will be found to be an effective and easily operated hand-power cutter at times when other power is not available.

| | |
|--------------------------------------|----------|
| 30-inch, squares 30 inches | \$300 00 |
| 33-inch, squares 33 inches | 350 00 |

CHALLENGE POWER PAPER CUTTER.

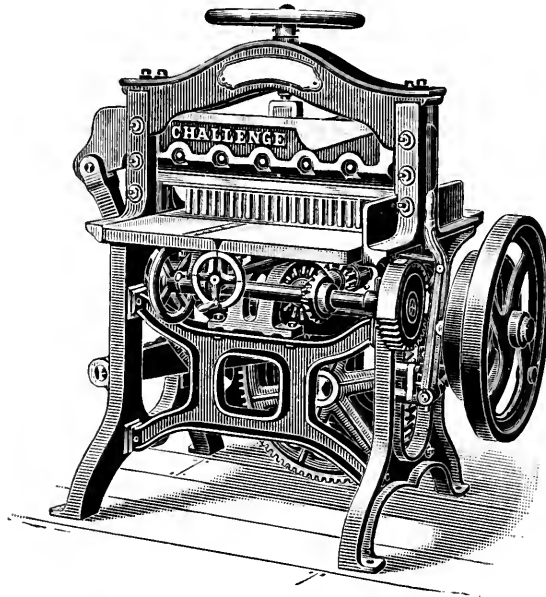

This cutter is provided with side gauges, back and front ; an extra reversible side gauge for front table ; split back gauge ; interlocking back gauge and clamp, for cutting narrow widths ; brass figured rules in bed, back and front. The slideways on which the knife bar moves are faced with gibs controlled by set screws, so that all wear in the slideways may be taken up.

| | |
|--------------------------------------|----------|
| 30-inch, squares 30 inches | \$400 00 |
| 32-inch, squares 32 inches | 450 00 |
| 36-inch, squares 36 inches | 650 00 |
| 40-inch, squares 40 inches | 750 00 |

PREMIUM CARD CUTTER.

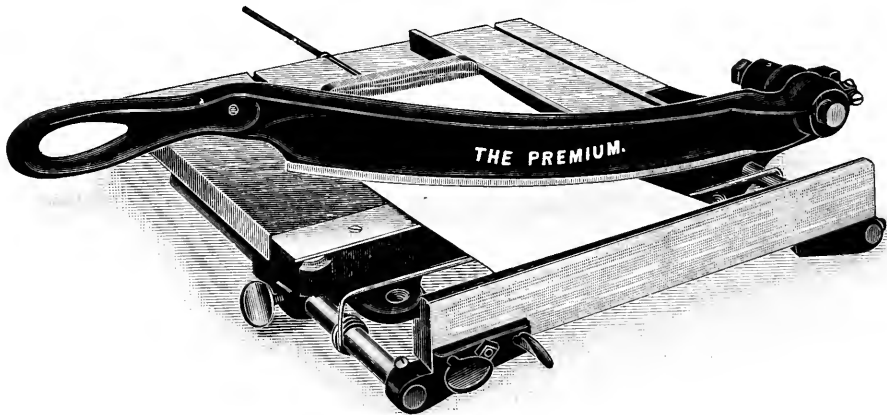

This is the popular, general, all-round machine, with a twelve-inch blade, meeting the requirements of a medium-sized cutter. A distinctive advantage is secured by a peculiar arrangement of the joint, by means of which a sheet of any length may be cut. By the simple adoption of a spring overhead, connected by a cord attached to the handle, the cutter is adapted to rapid work where a great number of small pieces of uniform size are to be cut.

Price \$10 00

MANUFACTURER'S CUTTER.

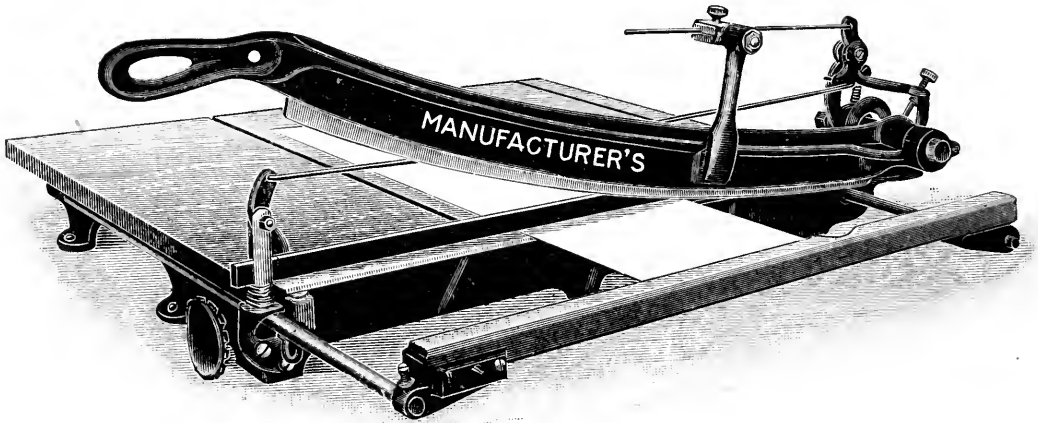

This is a strong machine, having a twenty-four inch blade, adapted as a whole to any reasonable work for which such a cutter may be used. An essential feature for manufacturing purposes is the *automatic grip or binder*, which securely holds the work in position before the descending blade begins to cut and throughout its movement. This machine has been long and favorably known to the trade.

Price \$25 00

STUDIO CUTTER.

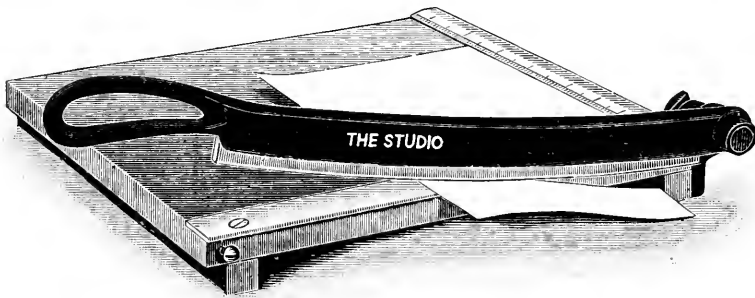

Has a ten-inch blade but no front gauge. Intended for small and light work. Makes a good clean cut.

Price \$3 00

SUCCESS CARD CUTTER.

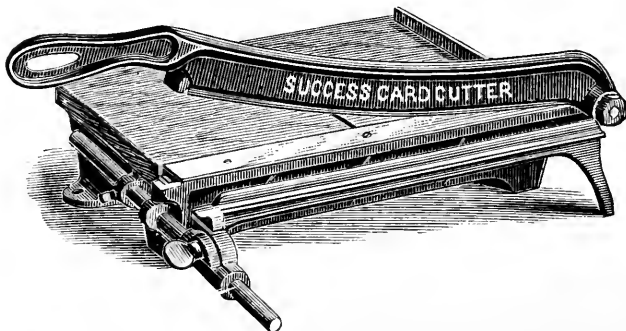

A well-made, reliable cutter, with movable side and front gauges. 12-inch knife . \$10 00

MONITOR TABLE SHEARS.

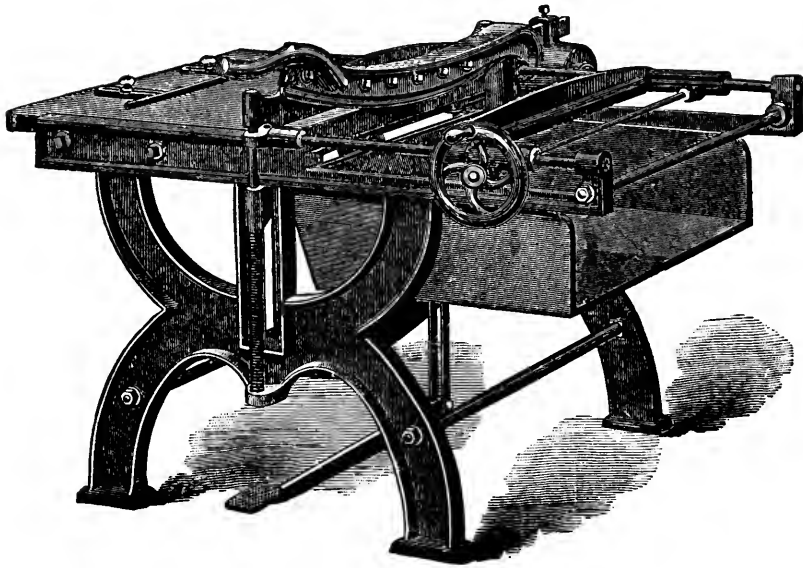

Style of 34-inch Extra Heavy Monitor Table Shears.

The Monitor Extra Heavy Table Shears are especially adapted for cutting the heaviest boards for bookbinders and for cutting perfectly square and clean edges. The knife-bar head is adjustable laterally and vertically, and another adjustment at the head enables the knife bar to be swung either way, so as to secure its perfect alignment with the bed, and insure a perfect shear cut. The screws holding the knife-bar head are $1\frac{3}{8}$ inches in diameter, and are turned at an angle of 55 degrees, which prevents the knife bar from springing. The clamp is parallel, and descends upon the whole sheet at once when the foot is placed on the clamping treadle. The gauge is operated by a hand wheel attached to a geared pinion and rack. The rack is of steel. One revolution of the hand wheel moves gauge four inches. The table is scored both ways, and is provided with side and end adjustable gauges.

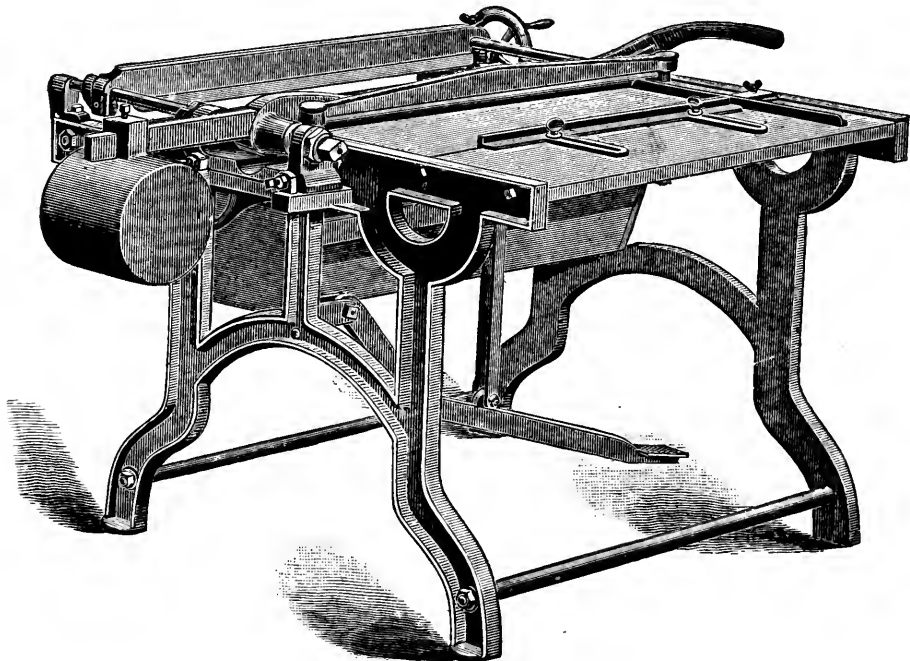

Style of 32-inch Monitor Table Shears.

| | |
|--|----------|
| Monitor Table Shears, 34 inches, extra heavy | \$150 00 |
| Monitor Table Shears, 32 inches | 110 00 |

MONITOR AUTOMATIC WIRE STITCHERS.

No. 00 MONITOR WIRE STITCHING MACHINE.

This new machine combines all the good points of the well-known No. 0 with valuable features peculiar to itself. It will handle work from one sheet to one and three-eighths inches in thickness, either flat or saddle, the change from one to the other being made instantly by simply lifting off or replacing the flat table. Wire ranging in size from No. 25 round to No. 19 to 21½ flat can be used with equal facility, an ingenious improvement in the feeding mechanism insuring the smallest wire being fed without bending or kinking. The spool tension is so arranged that just enough wire for one staple is delivered at a time, doing away with friction devices which require constant adjusting. This improved Monitor will be welcomed by those who desire one machine to handle a variety of work, as it is unqualifiedly guaranteed to do all that is claimed for it.

It is not a low-priced machine, but the best to be had at any price.

*For Prices and
Weights of Monitor
Automatic Wire
Stitchers, see page
1021.*

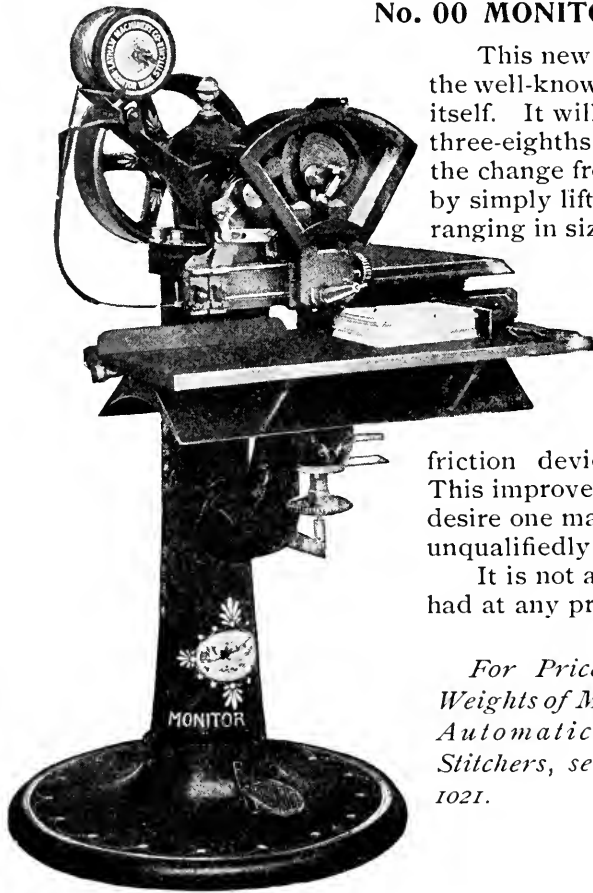

No. 00 Monitor Wire Stitcher.

The No. 00 Monitor will handle the largest range of work of any wire stitcher in the world.

No. 0 TWENTIETH CENTURY MONITOR WIRE STITCHER.

Our No. 0 is designed for flat or side stitching only, and has a range of work from ¼ inch to full 1¾ inches. It has all the same mechanism as the No. 00, with the exception that it does not have the saddle table for doing saddle stitching. It is provided with automatic clamp, if desired, for soft, spongy paper, which compresses the book firmly while being stitched, thus avoiding the breaking or tearing of the top and bottom sheets, or cover.

No change of parts for various thicknesses of work.

Guaranteed to stitch up to its fullest capacity.

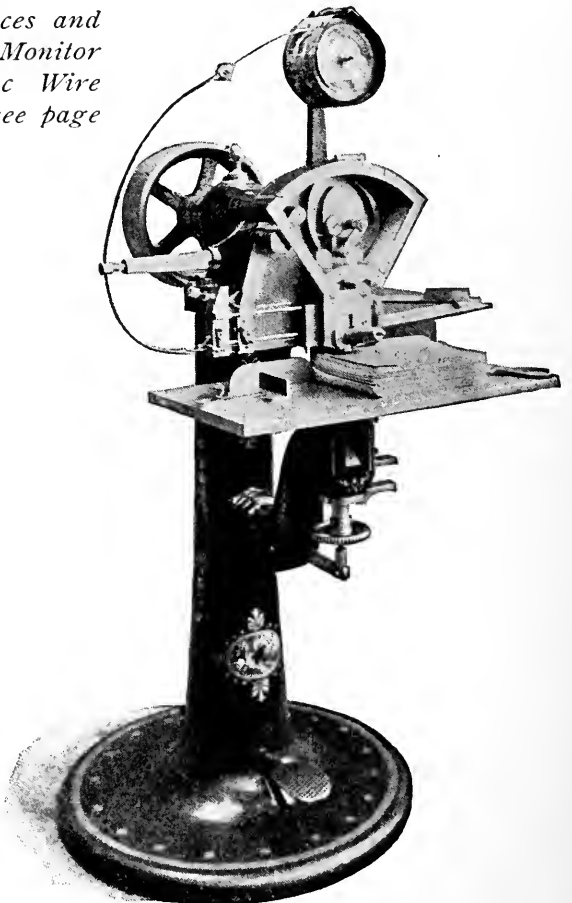

No. 0 Monitor Wire Stitcher.

Will stitch from ¼ inch to 1¾ inches.
Designed for flat work only.

MONITOR AUTOMATIC WIRE STITCHERS.*(Continued.)***TWENTIETH-CENTURY MONITOR WIRE STITCHER.**

The Twentieth-Century Monitor Stitchers are undoubtedly the finest stitchers ever produced. They will stitch one thickness of tissue paper with No. 30 wire up to their fullest capacity with round or flat wire without change of parts. Our latest improved spool tension works automatically, and at each stroke of the feed lever it releases sufficient wire only for the next staple. Users will appreciate this improvement. It has an indicator numbered 1, 2, 3, 4, 5, 6, which is adjusted instantly for various lengths of staples. The cutter is now provided with a separate cutting blade, which has two cutting surfaces, and which can be replaced at a cost of a few cents (heretofore new cutters cost \$1.25 each). This cutter can be taken out of machine or replaced by hand without the use of tools. The new straight and roll-feeding attachment feeds the wire into the machine perfectly straight, and produces a perfect square staple, which is absolutely necessary to accomplish thick, heavy stitching. Also provided with wire straightener, automatic gauge, flat and saddle table, back and side gauges, etc.

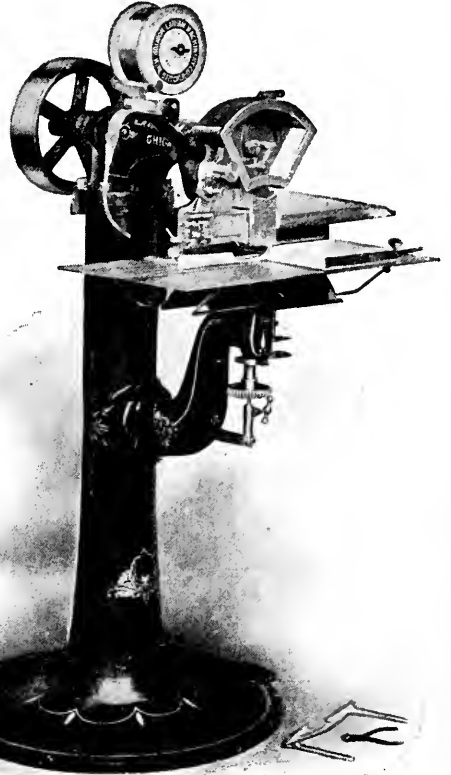

No. 1 Twentieth Century Monitor Wire Stitcher.
Capacity, $\frac{7}{8}$ inch.

No. 1 $\frac{1}{2}$ is of the same design.

**No. 2 $\frac{1}{2}$ MONITOR
WIRE STITCHER.**

The No. 2 $\frac{1}{2}$ Monitor is especially adapted for large pamphlet and calendar work. It has a drop of 16 inches, or a reach from clincher block to stand of 11 inches. It is constructed with a roll-feeding device which feeds the wire between two steel rollers, producing an evenness of feed and every staple of even length. Also equipped with improved spool tension, automatic gauge, flat and saddle table, gauges, etc.

This size machine can be run at a great speed, and is a big money maker.

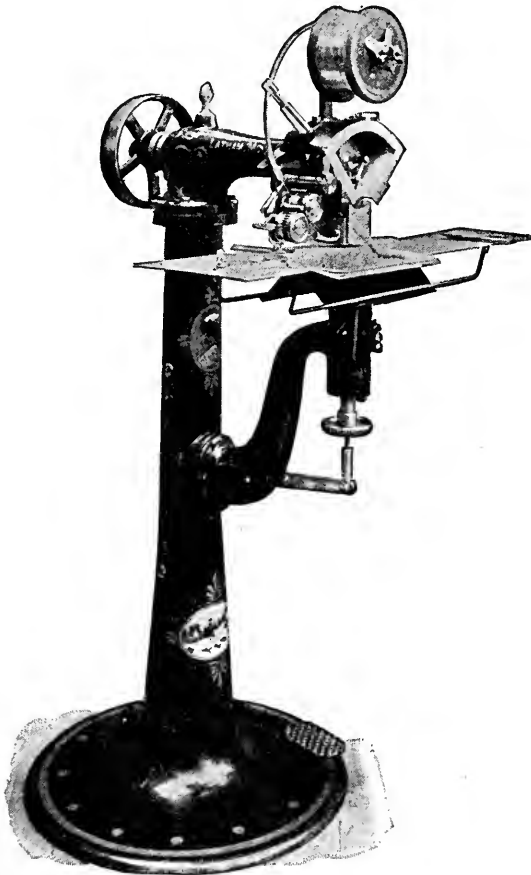

No. 2 $\frac{1}{2}$ Monitor Wire Stitcher.
Capacity, $\frac{1}{4}$ inch.

No. 1 $\frac{3}{4}$ and No. 2 are of the same design.

For Prices and Weights of Monitor Automatic Wire Stitchers, see page 1021.

MONITOR AUTOMATIC WIRE STITCHERS.

(Continued.)

No. 3 MONITOR WIRE STITCHER.

This No. 3 Monitor is provided with all the improvements as on the more expensive stitchers, and will do stitching as neatly and as quickly.

It is built on a leverage movement, is very simple, does not get out of order nor break. With care this machine will earn its purchase price in a few weeks.

*For Prices and Weights of
Monitor Automatic Wire Stitchers,
see page 1021.*

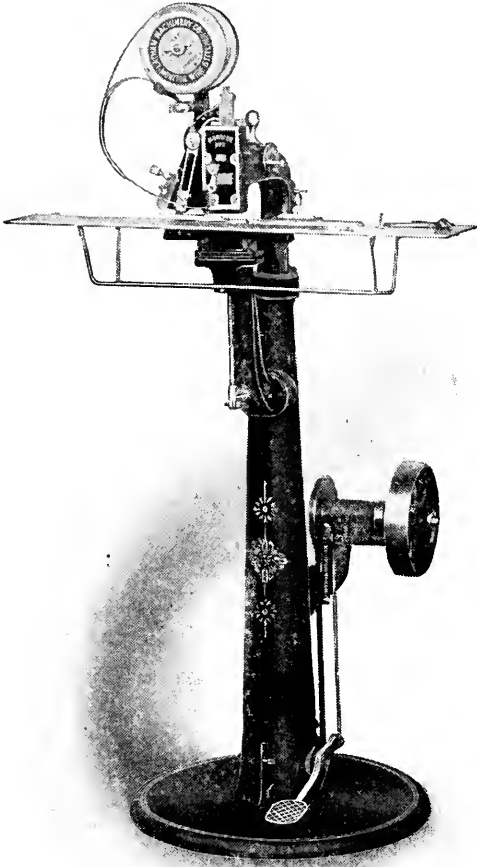

No. 3 Monitor Wire Stitcher.
Capacity, $\frac{1}{4}$ inch.

No. 4 MONITOR WIRE STITCHER.

For Foot Power.

To reach the demand of small offices not provided with power, we herewith show a small foot-power stitcher at a price to bring it within the range of all medium-sized offices.

It feeds direct from a spool, making its own staples (at a cost of less than two cents per thousand). Will stitch both flat and saddle work without change of parts for different thicknesses of work or different sizes of wire. It has its own pedestal, similar to our power machines, and is of the same high standard of workmanship and material.

Uses thick and thin round wire from Nos. 25 to 30.



No. 4 Monitor Wire Stitcher for Foot
Power.
Capacity, $\frac{1}{4}$ inch.

MONITOR AUTOMATIC WIRE STITCHERS.

(Continued.)

PRICES, WEIGHTS AND CAPACITIES OF MONITOR AUTOMATIC WIRE STITCHERS.

| | | Weight Boxed. | List Price. |
|-----------|---|---------------|-------------|
| No. 00 | Twentieth Century—combined roll and straight feed; capacity, 2 sheets to 1 3/8 inches; uses 25 round wire, 19x21 1/2 flat wire | . 680 lbs. | \$700 00 |
| No. 0 | Twentieth Century—combined roll and straight feed; automatic clamp; capacity, 1/4 inch to 1 3/8 inches; uses 19x21 1/2 flat wire; flat work only | . 575 lbs. | 600 00 |
| No. 1 | Twentieth Century—combined roll and straight feed; capacity, 2 sheets to 7/8 inch; uses 25, 26, 27, 28 and 30 round wire, 20x25 flat wire | . 450 lbs. | 450 00 |
| No. 1 1/2 | Twentieth Century—combined roll and straight feed; capacity, 2 sheets to 5/8 inch; uses 25, 26, 27, 28 and 30 round wire, 20x25 flat wire | . 400 lbs. | 300 00 |
| No. 1 3/4 | Roll Feed—capacity, 2 sheets to 1/2 inch; uses 25, 26, 27, 28 and 30 round wire, 20x25 flat wire | . 375 lbs. | 275 00 |
| No. 2 | Roll Feed—capacity, 2 sheets to 3/8 inch; uses 25, 26, 27, 28 and 30 round wire, 20x25 flat wire | . 350 lbs. | 200 00 |
| No. 2 1/2 | Roll Feed Calendar Machine—capacity, 2 sheets to 1/4 inch; uses 25, 26, 27, 28 and 30 round wire; length of arm, straight back, 11 inches; sloped down, 16 inches | . 340 lbs. | 175 00 |
| No. 3 | Direct Feed—same pattern as No. 4, with power added; capacity, 2 sheets to 1/4 inch; uses 25, 26, 27, 28 and 30 round wire | . 300 lbs. | 150 00 |
| No. 4 | Direct Feed (Treadle)—capacity, 2 sheets to 1/4 inch; uses 25, 26, 27, 28 and 30 round wire | . 270 lbs. | 100 00 |

All of the above have flat and saddle table except No. 0

TENNIS BOOK-SEWING MACHINE.

Designed for stitching blank books of every kind, and pamphlets and books not exceeding a thickness of three-eighths inch. Will sew through back or center, making stitches one-inch, half-inch, or quarter-inch long. Books sewed by this method are durable, and open perfectly. This machine is in use in almost every prominent blank-book factory in the United States.

In ordering steam power it is necessary to state diameter of shaft from which belt will be run to machine.

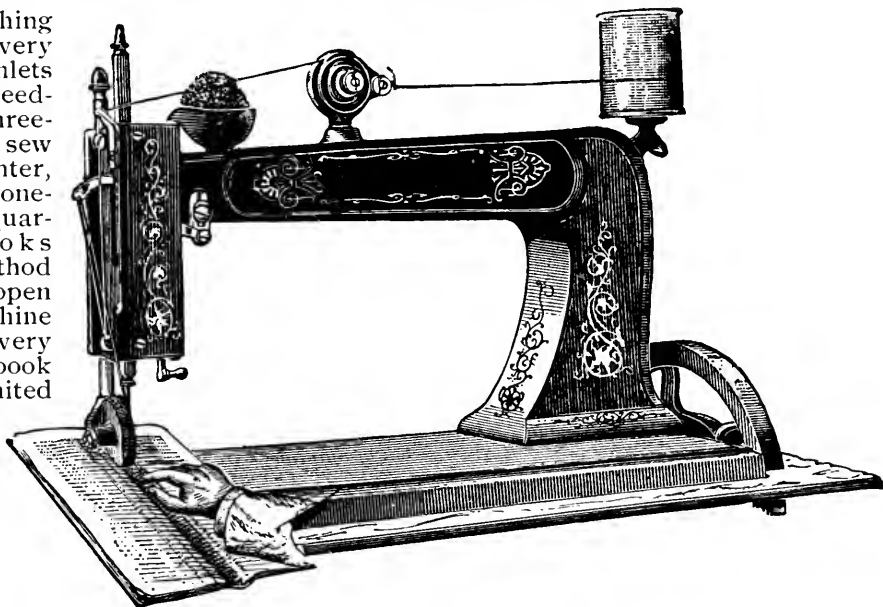

Length of Stitches.

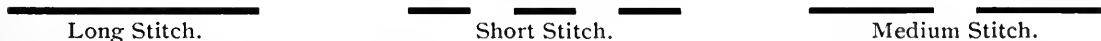

For foot power, with stand and table \$60 00
 For steam power, with variable speed, stand and pulleys, complete 70 00

PERFECTION WIRE STITCHERS.

Perfection Stitchers, as shown on this and following page, have for a number of years given invariable satisfaction with a minimum of trouble. They are exceedingly well made and strong. The adjustment from one length of staple to another is accomplished by changing a pin from one hole on dial plate to another.

These stitchers take wire from spools, and make staples from round or flat wire of any desired length within the capacity of each machine.

PERFECTION "G" WIRE STITCHER.

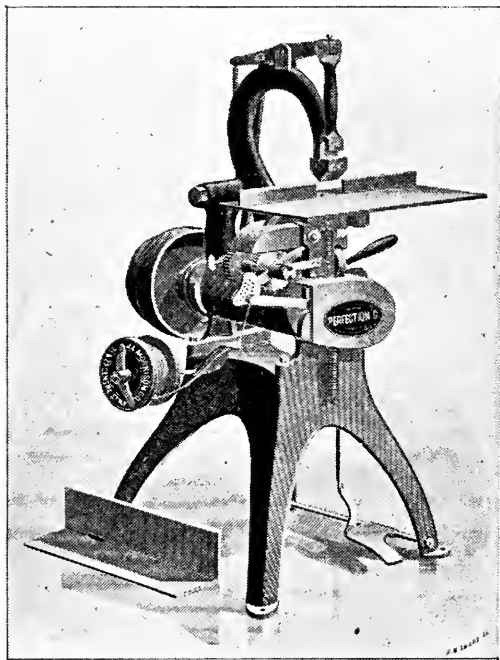

Power or Treadle.

Capacity, two sheets to almost 7/8-inch. Large trough and flat table. Uses 20 to 28 gauge wire.

- For steam power \$250 00
- For treadle and power combined 265 00
- For treadle only 260 00

No. 7 NEW PERFECTION WIRE STITCHER.

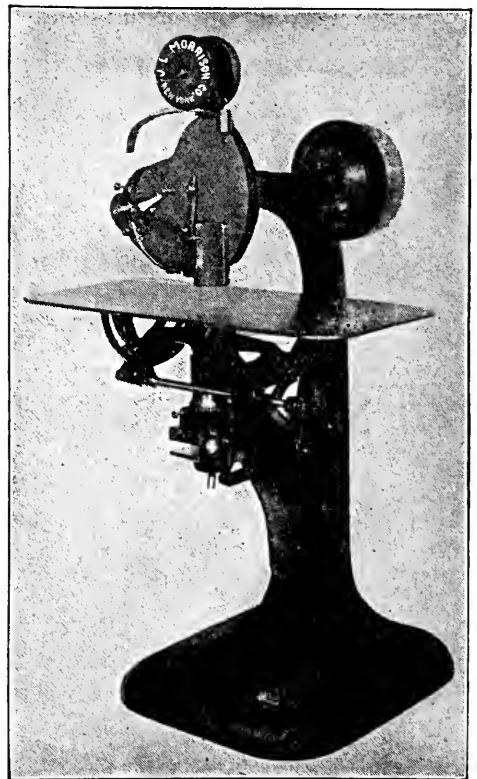

This machine has all modern improvements. It sets automatically for all thicknesses of work. The patent table is changeable from flat to saddle, or *vice versa*, without removal. There is an extra length of space between clinchers and

frame to accommodate large calendars and extra large publications. Constructed expressly to stitch heavy work with light wire, without change of parts, although heavy wire can be used if desired. Has the roller-feed device in its latest improved form, and patent supporting and clinching devices which are unexcelled.

Will stitch from one sheet to 3/4-inch, and will run wire as fine as No. 25, and also flat wire, 21x25, without changing any parts.

Price, complete \$300 00

PERFECTION "A" WIRE STITCHER.

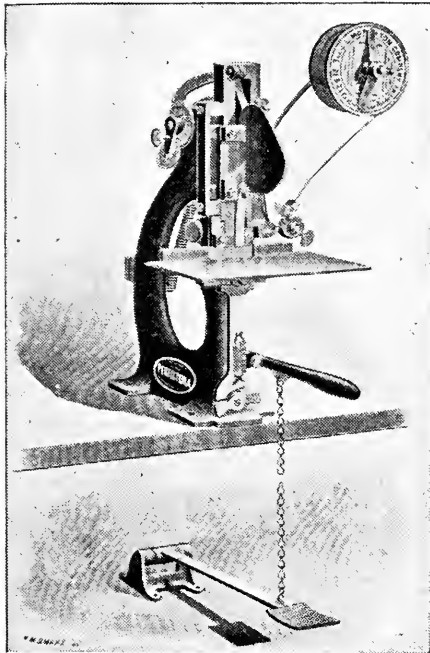

Hand or Foot Power.

It is adapted for work varying from two sheets to one-fifth inch in thickness. May be used with flat table or saddle, with wire of from 23 to 30 gauge. The saddle is extra long.

Perfection "A" Wire Stitcher, for hand or foot power \$90 00

PERFECTION "C" WIRE STITCHER.

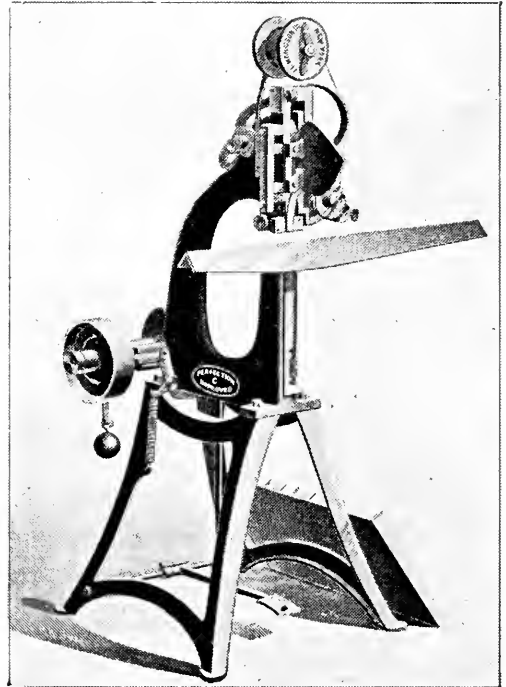

For Steam Power Only.

Specially adapted for pamphlet binding, stitching calendars, and all work up to one-fifth inch. Extra long saddle and flat table. Takes 23 to 30 gauge wire.

Perfection "C" Wire Stitcher, for steam power only \$150 00

BOOKBINDERS' WIRE ON SPOOLS.

The success of every wire stitching machine depends largely upon the quality of the wire used. We sell the best made.

A spool holds five pounds of wire. A case contains 20 spools (100 lbs.). Spools are 10 cents extra each, and are returnable less transportation charges. Do not return spools without previously sending us notice, as such notice may enable us to save you some expense.

As a rule, our prices for case lots (100 lbs of one size) are two cents per pound less than the single-spool price.

Current price list of wire will be sent on application, which consumers can depend upon as being the lowest obtainable for the best quality of wire.

The fluctuations in the cost of metals make it impossible to publish a standard list of prices.

GAUGES OF WIRE.

Round : Nos. 18 and 19
 Nos. 20, 21, 22
 Nos. 23, 24, 25, or 30 s.
 Nos. 26, 27, 28
 No. 30

Flat : Nos. 19×21, 19×21½, or 10 s.
 Nos. 20×23 and 20×25
 Nos. 21×25 or 60 s.
 Nos. 24×29

Wires Nos. 10 s, 30 s, and 60 s, are for Thompson machines only.

PERFECTION No. 4 WIRE STITCHER.
(POWER)

Specially Constructed for Stitching All Sizes of Calendars.

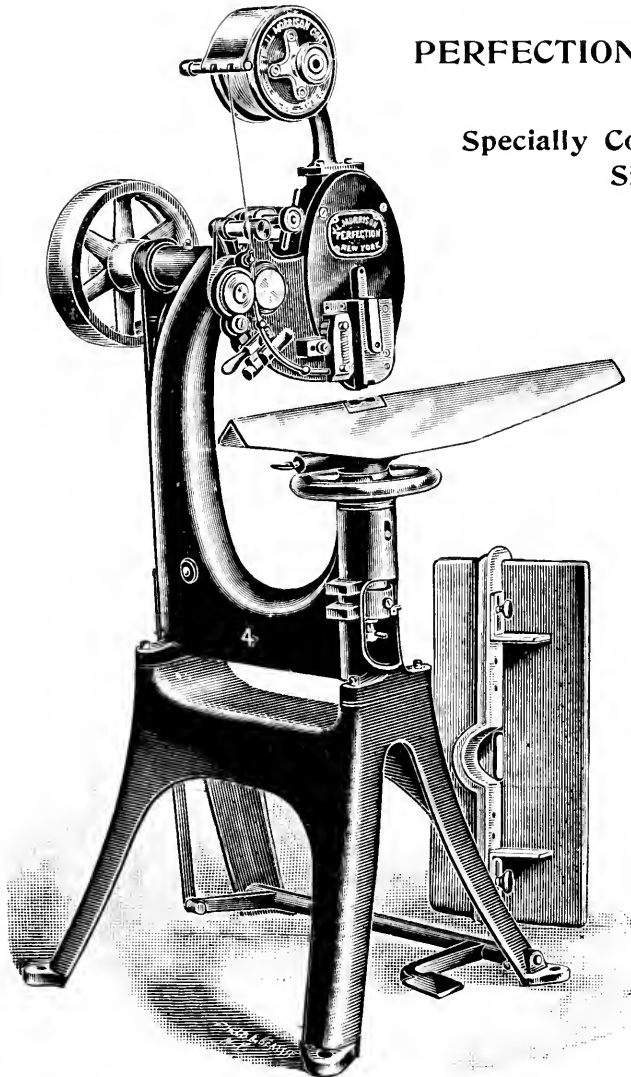

The Perfection No. 4 Wire Stitcher is the most perfect machine of its capacity extant, having up-to-date features not to be found in any other stitcher, and at a more than reasonable price.

The instant recognition and quick sales given this machine by the trade generally is proof positive of its being up to and beyond the high standard of the well-known Perfection Wire Stitchers.

The special features of the No. 4 Wire Stitcher are an improved spring-roll wire feed, an improved patented feed gear, improved wire-cutting devices, and an improved patented staple supporter. The saddle is extra large, and there is 15-inches of a drop to the arm of machine. The table, which is extra large, has 12 inches back space. These machines are simple, rapid and almost noiseless in operation.

Price \$250 00

Capacity, 2 sheets to 1/2 inch. Wire used, 23 to 28 gauge.

SUCCESS WIRE-STITCHING MACHINES.

These machines are the sole occupants of the field between the crude staple binders and expensive wire stitchers. The No. 1 is for hand lever only; capacity, 3/16-inch for both flat and saddle work. It makes its own staples. A forty-cent spool of wire will make more than 14,000 staples, and 14,000 ready-made staples cost \$2.10, showing a saving on staples alone of \$1.70 on every 7000 pamphlets stitched, besides doing better and neater work. The No. 2 is a much heavier machine, working on the same principle by lever or treadle. It takes a regular five-pound spool of wire. Its capacity is 3/8-inch; has flat and saddle table; distance from stitch to back is eight inches. These machines are guaranteed by the makers.

- Success Wire Stitcher No. 1, for lever only; capacity, 3/16-inch \$40 00
- Success Wire Stitcher No. 2, with treadle; capacity, 3/16-inch 65 00
- Spools of wire for No. 1, each 0 40

The No. 2 Stitcher takes regular five-pound spools of No. 25 wire.

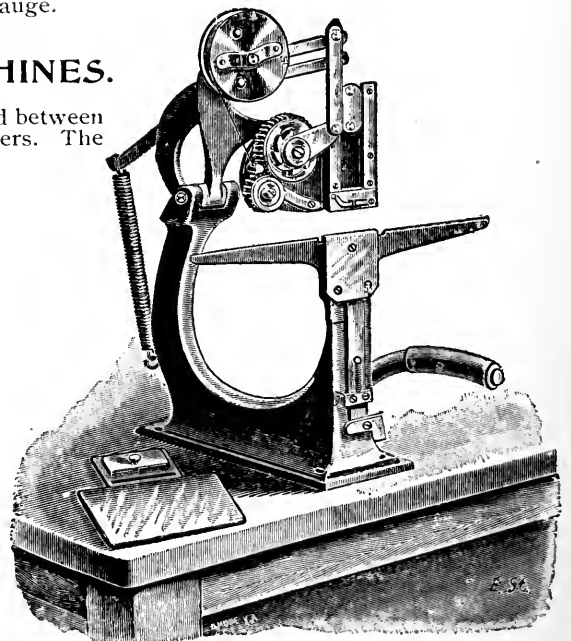

BOOKBINDERS' WIRE ON SPOOLS.

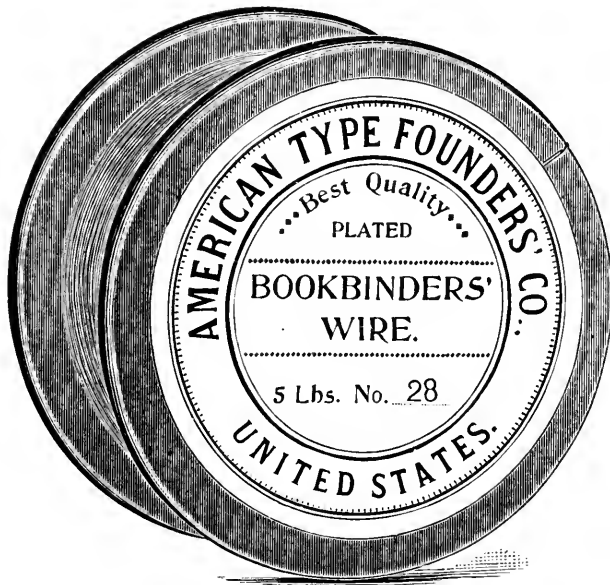

The wire we carry in stock is the very best procurable, and it will be sold at prices as favorable as any prices obtainable elsewhere for the same grade of quality.

There is no economy in poor wire, as the trouble it occasions much more than offsets any saving in the first cost.

The standard sizes are printed on page 1023, but without prices, as the fluctuations in the cost of metals make it impracticable to publish a standard list. Current price list will be sent on application, which consumers can depend upon as being the lowest obtainable for the best quality of wire.

The table below will save users of wire a great deal of time, and enable them to estimate accurately the cost of wire in each job and the amount necessary to order.

WIRE STAPLE TABLE: SHOWING NUMBER OF STAPLES TO ONE POUND OF WIRE.

To ascertain the number of staples to one pound of wire, measure *full length* of wire in staple, go to first column on left of table and pass down same until you reach the size that corresponds with staple measured; pass along to right until you reach size of wire used, shown by top row of figures. Example: If your staple measures 1½ inches, and the size of wire is No. 28, there are 11,940 staples to one pound, as shown in table.

| Length of Wire in Staple. | 18 | 19 | 20 | 21 | 22 | 23 | 24 | 25 | 26 | 27 | 28 | 29 | 30 |
|---------------------------|------|---------|---------|------|---------|-------|---------|---------|----------|----------|----------|----------|-------|
| ½ inch | 4104 | 5394 | 7408 | 8856 | 11594 | 14544 | 17142 | 22640 | 28236 | 31578 | 35820 | 40678 | 47058 |
| 5/8 inch | 3283 | 4315 | 5926 | 7084 | 9275 | 11635 | 13713 | 18112 | 22588 | 25262 | 28656 | 32542 | 37646 |
| ¾ inch | 2736 | 3596 | 4938 | 5904 | 7729 | 9696 | 11428 | 15093 | 18824 | 21052 | 23880 | 27118 | 31372 |
| 7/8 inch | 2345 | 3082 | 4233 | 5060 | 6625 | 8310 | 9795 | 12937 | 16134 | 18044 | 20468 | 23244 | 26890 |
| 1 inch | 2052 | 2697 | 3704 | 4428 | 5797 | 7272 | 8571 | 11320 | 14118 | 15789 | 17910 | 20339 | 23529 |
| 1 1/8 inch | 1824 | 2397 | 3292 | 3936 | 5152 | 6464 | 7618 | 10062 | 12549 | 14034 | 15920 | 18079 | 20914 |
| 1 1/4 inch | 1641 | 2157 | 2993 | 3542 | 4637 | 5817 | 6856 | 9056 | 11294 | 12631 | 14328 | 16271 | 18823 |
| 1 3/8 inch | 1492 | 1961 | 2693 | 3220 | 4216 | 5288 | 6233 | 8232 | 10267 | 11482 | 13025 | 14792 | 17112 |
| 1 1/2 inch | 1368 | 1798 | 2469 | 2952 | 3864 | 4848 | 5714 | 7546 | 9412 | 10526 | 11940 | 13559 | 15686 |
| 1 5/8 inch | 1262 | 1659 | 2279 | 2724 | 3567 | 4475 | 5274 | 6966 | 8688 | 9716 | 11021 | 12516 | 14479 |
| 1 3/4 inch | 1172 | 1541 | 2116 | 2530 | 3312 | 4155 | 4897 | 6468 | 8067 | 9022 | 10234 | 11622 | 13445 |
| 1 7/8 inch | 1094 | 1438 | 1975 | 2361 | 3091 | 3878 | 4571 | 6037 | 7529 | 8420 | 9552 | 10847 | 12548 |
| 2 inch | 1026 | 1348 | 1852 | 2214 | 2898 | 3636 | 4285 | 5660 | 7059 | 7894 | 8955 | 10169 | 11764 |
| 2 1/8 inch | 965 | 1269 | 1743 | 2083 | 2728 | 3422 | 4033 | 5327 | 6643 | 7430 | 8428 | 9571 | 11072 |
| 2 1/4 inch | 912 | 1198 | 1646 | 1968 | 2576 | 3232 | 3809 | 5031 | 6274 | 7017 | 7960 | 9039 | 10457 |
| 2 3/8 inch | 864 | 1135 | 1559 | 1864 | 2440 | 3061 | 3608 | 4766 | 5944 | 6648 | 7541 | 8563 | 9906 |
| 2 1/2 inch | 820 | 1078 | 1481 | 1771 | 2318 | 2908 | 3428 | 4528 | 5647 | 6315 | 7164 | 8135 | 9411 |
| 2 5/8 inch | 781 | 1027 | 1411 | 1686 | 2208 | 2770 | 3265 | 4312 | 5378 | 6014 | 6822 | 7748 | 8963 |
| 2 3/4 inch | 746 | 980 | 1346 | 1610 | 2108 | 2644 | 3116 | 4116 | 5133 | 5741 | 6512 | 7396 | 8556 |
| 2 7/8 inch | 713 | 938 | 1288 | 1540 | 2016 | 2529 | 2981 | 3937 | 4910 | 5491 | 6229 | 7074 | 8184 |
| 3 inch | 684 | 899 | 1234 | 1476 | 1932 | 2424 | 2857 | 3773 | 4706 | 5263 | 5970 | 6779 | 7843 |
| 3 1/8 inch | 656 | 863 | 1185 | 1416 | 1855 | 2327 | 2742 | 3622 | 4517 | 5052 | 5731 | 6508 | 7529 |
| 3 1/4 inch | 631 | 829 | 1139 | 1362 | 1783 | 2237 | 2637 | 3483 | 4344 | 4858 | 5510 | 6258 | 7239 |
| 3 3/8 inch | 608 | 799 | 1097 | 1312 | 1717 | 2154 | 2539 | 3354 | 4183 | 4678 | 5306 | 6026 | 6971 |
| 3 1/2 inch | 586 | 770 | 1058 | 1265 | 1656 | 2077 | 2448 | 3234 | 4033 | 4511 | 5117 | 5811 | 6722 |
| No. of ft. in 1 lb. | 171 | 224 1/4 | 308 3/8 | 369 | 483 1/2 | 606 | 714 1/4 | 943 3/8 | 1176 1/2 | 1315 3/4 | 1492 1/2 | 1694 1/4 | 1960 |

No. 6 ACME TREADLE STAPLE BINDER.

**The Only Staple Binders
Which Will Not Clog.**

The No. 6 Acme Wire Staple Binder does a greater range of work, and does better work, than any other staple binder. At one stroke of the treadle it drives, clinches and releases the staple, each operation being independent, though continuous. It holds two hundred and fifty staples at a charge, and round or flat and fine or coarse staples may be used. Staples are fed automatically to driver by positive pressure on both legs, and clogging is prevented by a device which effectually prevents more than one staple getting under the driver at a time. The clinch is perfect on any thickness. There is ample room for putting in and taking out work, as the driver arm lifts more than an inch above the table after each clinch. There is a space of $8\frac{1}{2}$ inches under the arm for calendar work. The treadle has a positive movement. Every machine is furnished with a strong iron stand. Will bind to a thickness of $\frac{1}{4}$ inch through any kind of paper, and is furnished with both flat and saddle-back tables, with gauges on the flat bed. For hard or coated papers, when the work is heavy, flat wire staples are used.



Acme Staple Binder No. 6.
For treadle, with flat and saddle tables.

Price, \$40.00

PRICES OF ACME TREADLE STAPLE BINDERS.

| | |
|--|---------|
| No. 6, Acme Wire Staple Binder, capacity $\frac{1}{4}$ -inch and under, on all kinds of paper, for round or flat wire, with table and treadle complete | \$40 00 |
| No. 4 Acme Wire Staple Binder, capacity $\frac{1}{4}$ -inch and under, on ordinary printing paper, for round fine wire only, with table and treadle complete | 27 00 |

For prices of Staples, see following page.

No. 4 ACME TREADLE STAPLE BINDER.

**The Only Staple Binders
Which Will Not Clog.**

The No. 4 Acme is very similar in appearance to the No. 6, and will stitch the same thickness on ordinary paper, but it uses only round fine staples, which cannot be used successfully on coated or filled paper unless such work is light. This machine is specially adapted for stapling the average run of pamphlets, calendars, sample work, etc. It does both flat and saddle-back work. It has the device for prevention of clogging, and the clinching is done by the pressure of the blade while driving the staple. Holds two hundred and fifty staples at a charge.

**UTILITY OF THESE
MACHINES.**

The addition of one of the Acme Treadle Staple Binders to the plant of small or moderate-sized printing offices, in towns in which there are no binderies, will make it easy and profitable to bind pamphlets, receipt books and other work. In towns where there are binderies they enable printers to save time, save handling of stock, and to avoid losses and damage in transit. All the staple binding machines in use were invented by one man, and the Acmes are the latest and most efficient. Like all such machines there is a certain knack to be acquired in order to handle them to the best advantage. Operators should read directions (which accompany the machines) very carefully.



Acme Staple Binder No. 4.

Price, \$27.00

STAPLES FOR ACME BINDERS.

| | |
|---|--------|
| For Acme Binder No. 6: No. 20, $\frac{3}{16}$ inch, round; No. 21, $\frac{1}{4}$ -inch, round; No. 22, $\frac{5}{16}$ -inch, round; No. 23, $\frac{1}{4}$ -inch, flat; No. 24, $\frac{5}{16}$ -inch, flat—per box of 5000 of one size | \$1 25 |
| For No. 4: No. 20, $\frac{3}{16}$ -inch, round; No. 21, $\frac{1}{4}$ -inch, round, and No. 22, $\frac{5}{16}$ -inch, round—per box of 5000 of one size | 1 25 |



**ACME
STAPLE BINDER
No. 1.**

The most satisfactory low-priced staple binder made. *It will not clog*, as only one staple can get under the driver at one time. The frame swings on a pivot, and lifts high enough to give ample room for putting in and taking out the work—an advantage not obtainable on other low-priced staple binders. It holds one hundred staples at a charge. Binds $\frac{1}{4}$ -inch and under. The staple is fed automatically under the driver, which descends and drives it through the paper, the pressure clinching the staple tight on the under side. Uses flat staples only.

Price \$6 00
 Staples : No. 23A, $\frac{1}{4}$ -inch, flat ; No. 24A, $\frac{5}{16}$ -inch, flat—per box of 5000 of one size 1 25

**SURE SHOT
STAPLE
BINDER
No. 1.**

The most reliable binder for office use. Holds one hundred staples at a charge. Works on the same principle as the Acme No. 1, described above, but has no lever. Binds from two to fifty sheets.



Price \$3 00
 Staples : No. 23A, $\frac{1}{4}$ -inch ; No. 24A, $\frac{5}{16}$ -inch—per box of 5000 of one size 1 25

BREECH LOADER STAPLE BINDER.

This is a handy machine for office use. Can be put to a great variety of uses. Binds paper or pamphlets from two to fifty sheets with wire staples; holds one hundred staples at a charge; feeds them out automatically; inserts them into the work, and clinches them on the under side.

Price \$3 00
 Staples: C, $\frac{3}{16}$ -inch; D, $\frac{1}{4}$ -inch; E, $\frac{5}{16}$ -inch—per box of 1000 0 50

Only one size of staples in a box.

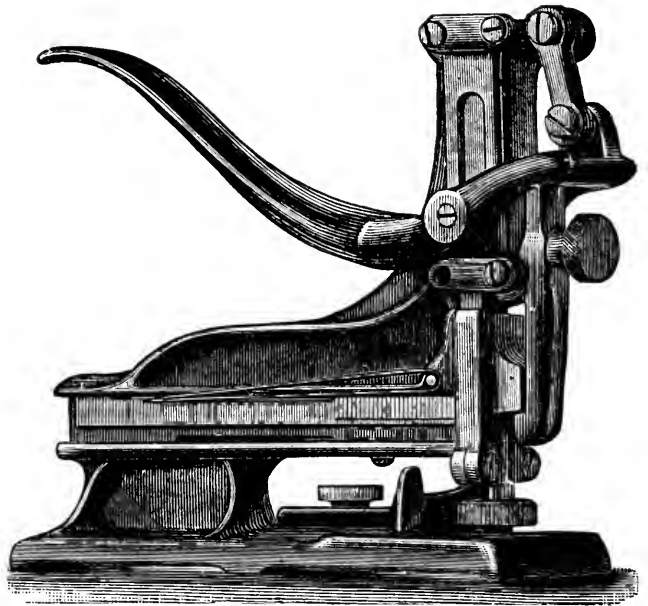

HERCULES WIRE STAPLE BINDER.

For Hand or Treadle.

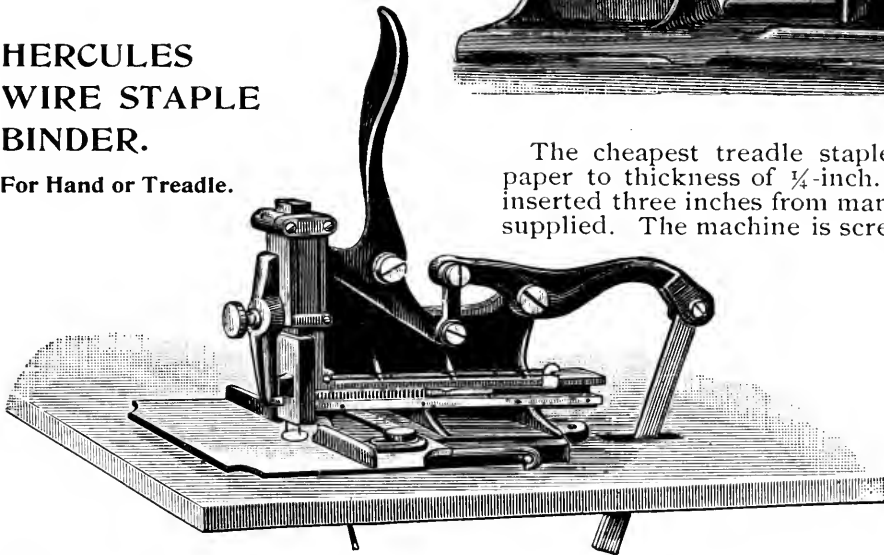

The cheapest treadle staple binder. Binds paper to thickness of $\frac{1}{4}$ -inch. Staples can be inserted three inches from margin. No table is supplied. The machine is screwed on a bench, and the treadle is screwed to the floor, connecting by means of a rod and spring.

Sold also for hand power only. Only one size of staples in a box.

Price, with treadle \$10 00
 Staples: F, $\frac{3}{16}$ -in.; G, $\frac{1}{4}$ -in.; H, $\frac{5}{16}$ -in.; K, $\frac{3}{8}$ -in.—per box of 5000 of one size 1 25

OTHER STAPLE BINDERS.

No. 7 Staple Binder binds paper $\frac{5}{16}$ inch thick. Complete with table and treadle . . . \$32 00
 No. 9 Staple Binder binds paper $\frac{1}{4}$ -inch thick. Complete with table and treadle . . . 36 00
 No. 8 Saddle Back Staple Binder takes $\frac{3}{16}$ -inch staples only; designed for saddle-back work, but will take flat work by adding flat table; with saddle back only, \$30 00; with flat and saddle-back tables 31 50
 Lightning Staple Binder No. 1 staples through $\frac{1}{4}$ -inch paper; No. 2 staples through $\frac{5}{16}$ -inch paper; each complete with treadle 24 00

WIRE STAPLES.

The following are the prices of staples for Staple Binders not illustrated:

For No. 9 Staple Binder: Staples No. 1 $\frac{1}{2}$, $\frac{3}{16}$ -inch long; No. 2, $\frac{1}{4}$ -inch long; No. 3, $\frac{5}{16}$ -inch long—per box of 5000 of one size \$1 25
 For No. 8 Saddle Back Staple Binder: Staples No. 1, $\frac{3}{16}$ -inch long—per box of 5000 1 25
 For No. 7 Staple Binder: Staples No. 4, $\frac{3}{16}$ -inch long; No. 5, $\frac{1}{4}$ -inch long; No. 6, $\frac{5}{16}$ -inch long; No. 6 $\frac{1}{2}$, $\frac{3}{8}$ -inch long—per box of 5000 of one size 1 25
 For Lightning Staple Binder No. 1: Staples No. 7, $\frac{3}{16}$ -inch long; No. 8, $\frac{1}{4}$ -inch long; No. 9, $\frac{5}{16}$ -inch long—per box of 5000 of one size 1 25
 For Lightning Staple Binder No. 2: Staples No. 10, $\frac{3}{8}$ -inch long; No. 11, $\frac{7}{16}$ -inch long; No. 12, $\frac{1}{2}$ -inch long—per box of 5000 of one size 1 25

MONITOR ROUND-CORNER, PUNCHING, INDEX CUTTING MACHINE.

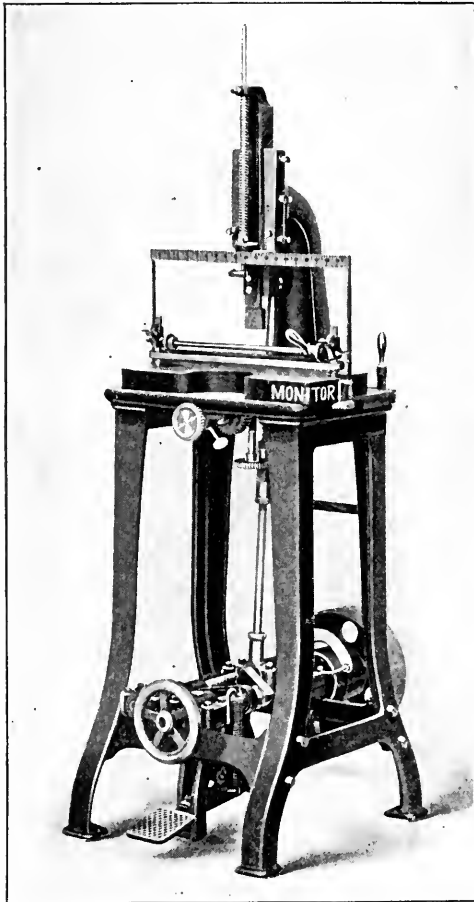

Combination Machine, for Power, complete, \$180.00.

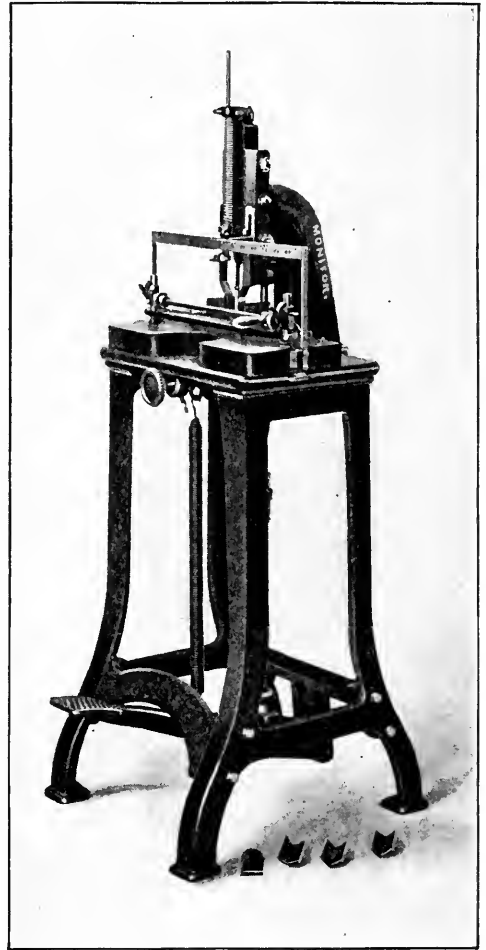

Combination Machine, Foot Power, complete, \$120.00.

A very desirable machine. By foot, it cuts easily through card or paper $1\frac{1}{2}$ inch thick ; by power, 3 inches. The table, besides having adjustable guides and a full-length clamp to hold the work during the cut, is movable from right to left, or *vice versa*, by means of a rack and gear operated by the hand wheel in front. A graduated scale and index above the table enables the operator to work quickly and with accuracy. The knives, Nos. 1, 2 and 3 (illustrated), or three of one No., are furnished with each complete machine.

By removing sliding table and index scale, and substituting a punch or round-corner cutter for the index knife, this machine is easily changed into a punching machine or round-corner cutting machine. In ordering punches and dies be guided by following diagram, and order by number or initial on diagram.

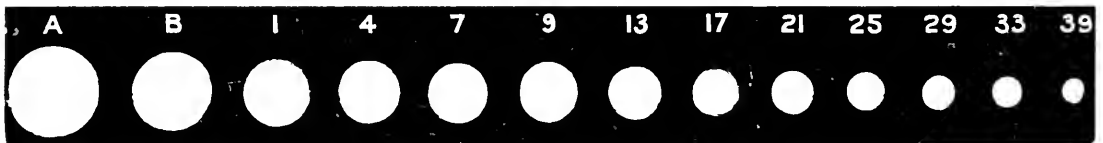
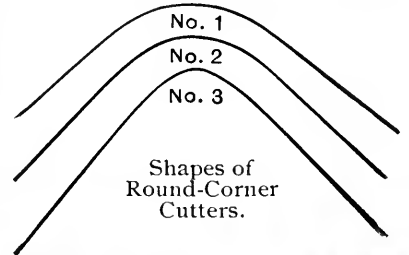

| | |
|---|----------|
| For foot power, complete with sliding table and index scale, one index knife, one punch and die, and three round-corner knives ; weight, crated, 435 lbs. | \$120 00 |
| For power, complete with same attachments as above ; weight, crated, 550 lbs. | 180 00 |
| Foot Power Index Machine, with round or square knife | 100 00 |
| Extra punch and die, per set | 2 50 |
| Extra round-corner knives, each | 1 50 |
| Extra index knives, each | 2 50 |

MONITOR PUNCHING AND ROUND-CORNER CUTTING MACHINES.

Furnished for power or foot power. With foot power will cut easily through card or paper 1½ inches thick, and with power through card or paper 3 inches thick. The cutter block is furnished of either wood or composition metal which does not injure the knives, and is so set as to be readily adjusted or removed. The head is rigid, and there is no spring or deflection in the punch or cut.

Order punches by the initials and numbers on the diagram printed on opposite page.

Each machine ordered for round-corner cutting is furnished with one each of the three knives illustrated on opposite page, or three knives of any one size, if desired.

- Foot Power Round-Corner Machine, with three knives (shapes of knives illustrated on page 1030) \$75 00
- Foot Power Punching Machine, with one punch and die 75 00
- Power Round-Corner or Punching Machine, heavier pattern, with extras as above, each 135 00
- Round-corner knives, each 1 50
- Punch and die, per set 2 50

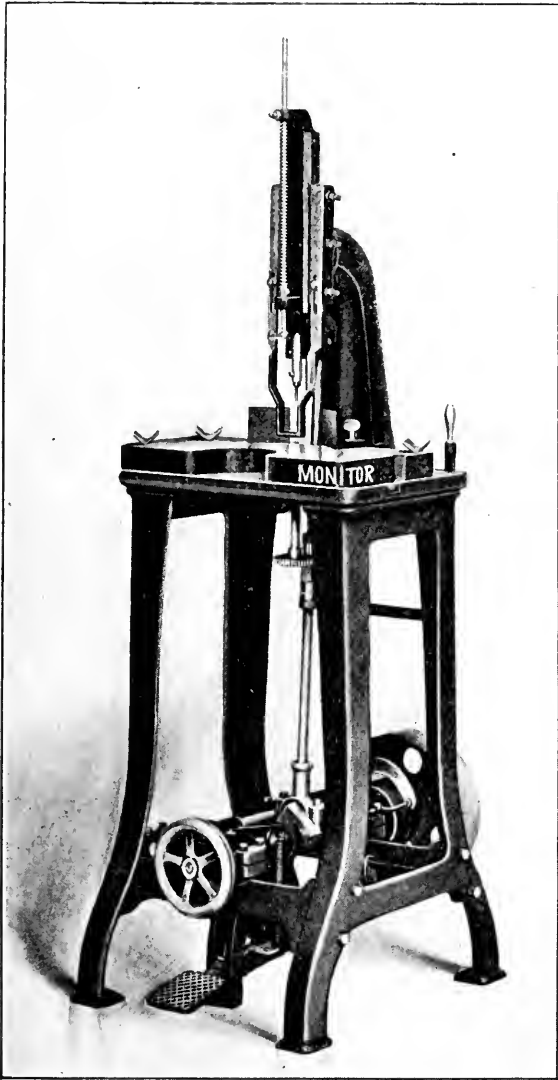

For Power.

JOB BACKER.

This has ample strength and is accurately fitted. It is extra heavy and reinforced at the corners. The boxes are phosphor bronze, and the screw and jaw are of steel.

- No. 0 takes 19-inch book \$65 00
- No. 1 takes 21-inch book 70 00
- No. 2 takes 24-inch book, extra heavy . . 80 00
- No. 3 takes 29-inch book, extra heavy . . 90 00
- Boxing extra.

SPECIAL NOTICE.—We are prepared to quote favorable prices for all kinds of bookbinders' machinery and tools, new or second-hand. In writing for quotations time will be saved if the requirements of customers are very specifically stated.

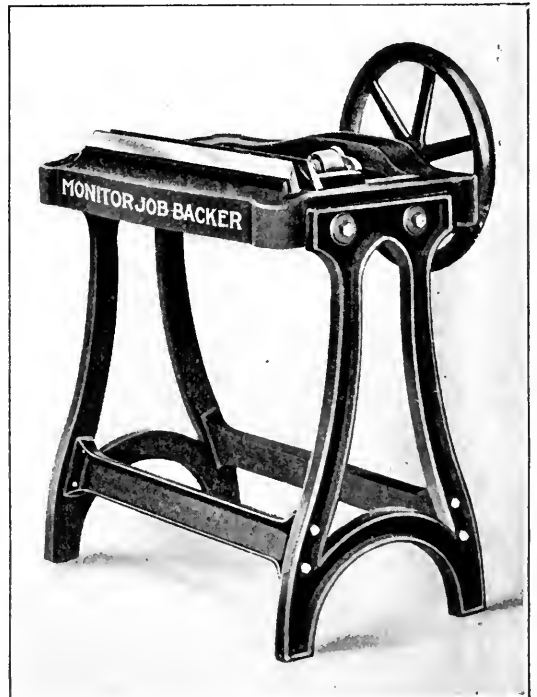

THE STERLING ROUND-CORNERING MACHINE.

**Simple in Construction
Moderate in Price
and Rapid.**

**Designed to meet the
Requirements of
Bookbinders and
Printers.**

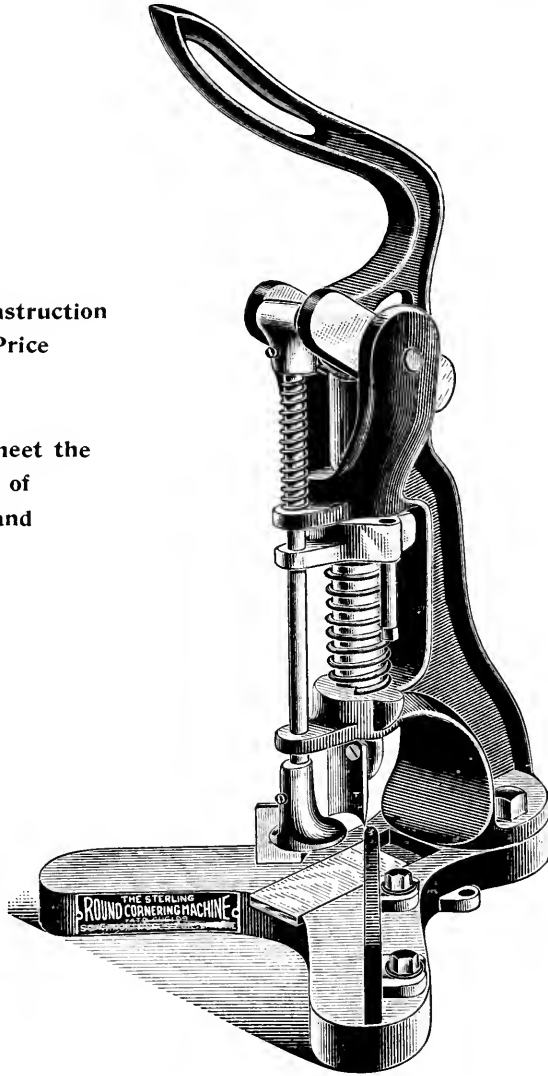

The Sterling Round-Cornering Machine is the best built machine for the purpose ever devised, and is particularly desirable in printing offices and binderies which aim to be progressive. It is thoroughly new in design, and the fact that the United States Patent Office has allowed all claims in their broadest and most comprehensive form, proves that the invention is original.

It costs very little to round-corner a thousand catalogues or booklets with this machine. A boy of average intelligence can do the job in from ten to fifteen minutes. A thousand cards can be round-cornered in much less time.

Every part of the machine is made with the utmost care, and none but the very best materials are used in its construction.

Price \$15 00

H. B. Brooks, Bookbinder and Manufacturing Stationer, Salem, Mass.: "Enclosed find check for \$15.00 for the Round-Cornering Machine. I have found the machine satisfactory in every particular, and the printers and binders who first investigate and adopt the Sterling will be sure to get better profits and more of them."

Richard Evans, Blank Book Manufacturer, New York: "I am more than pleased to say that the Sterling Round-Cornering Machine is giving me the greatest satisfaction."

J. P. Corvell, Printer and Publisher, Easton, Pa.: "I am well pleased with your Cornering Machine, and regard it as a most useful article, and use it daily."

E. W. Raymond, Printer, Independence, Iowa: "The Sterling Round-Cornering Machine is just what I wanted. It's a dandy!"

THE "PROGRESS" FOOT-POWER ROUND-CORNERING AND PUNCHING MACHINE.

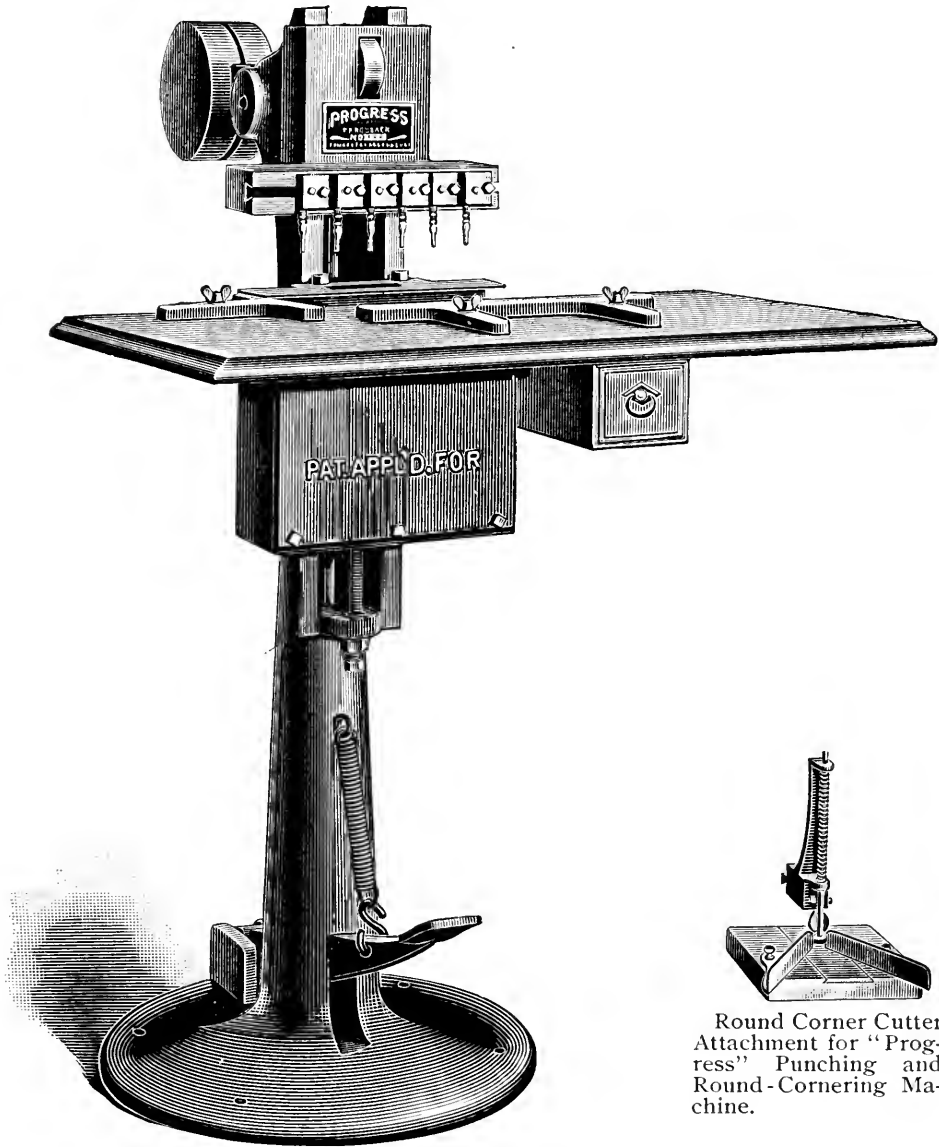

Round Corner Cutter Attachment for "Progress" Punching and Round-Cornering Machine.

This machine is very heavy and nicely finished. The stand is cast in one piece, has adjustable gauges, and built in such a manner that the knife will not spring. All punches and dies are hardened and drawn to the proper temper, and are turned off center, forming an eccentric by which the male die can be made to register accurately with the female die, and securely locked in the correct position. Punches and dyes are interchangeable and adjustable from 1 1/4 up to 11 inches. Any size of punch can be used. A small size punch will go through 3/8-inch paper, and a large punch through 1/4-inch paper. Three knives and four punches with each complete machine. Four punches with punching machine only. The corner-cutting attachment has an automatic clamp which securely holds paper while being cut.

This machine is the latest of its kind on the market, and is guaranteed to be strictly as represented.

| | |
|--|----------|
| Price, complete | \$125 00 |
| Price, without corner-cutting attachment | 110 00 |
| Extra punches and dies, per set | 2 50 |

THE ROSBACK MULTIPLEX PUNCHING MACHINE.

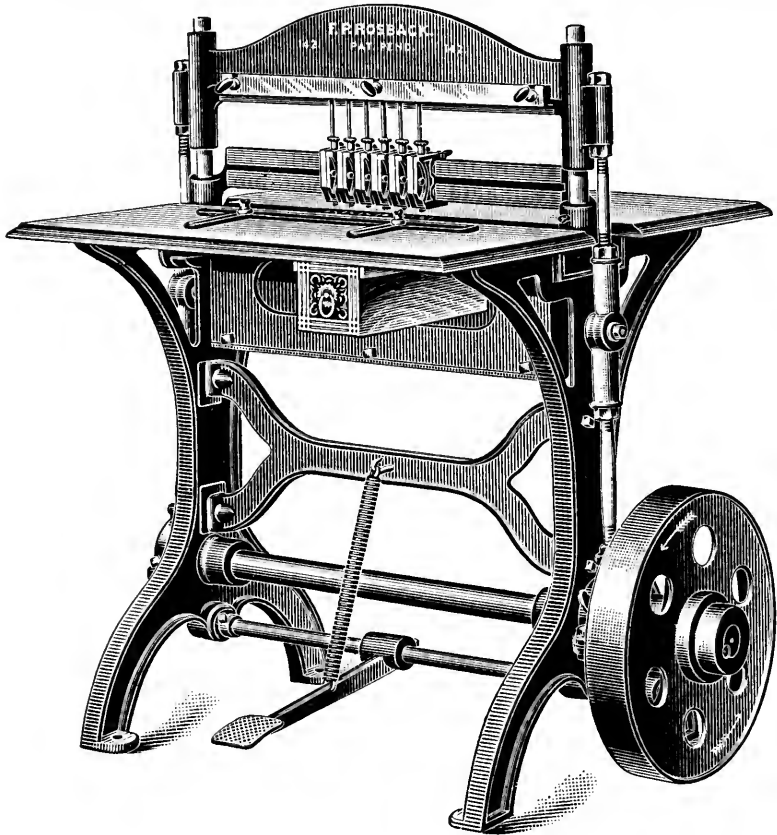

The frame is extra heavy, with finished bearings, and is securely braced and bolted. The driving shaft is also large, and has four-inch bearings on each end, thus insuring a straight down stroke, without spring.

The head which operates the punches is arched, and supported on each end by long guide pins, nicely fitted. Any portion of the machine can be used without unnecessary strain to the rest of the machine.

The punches are made from the best of tool steel (drill rod), and travel through guides with a bearing of five inches in length. The punch passes through this guide a little off center, forming an eccentric, by which the male die can be made to accurately line with the lower die. These guides are adjustable up and down, and act as strippers.

The dies are inserted in iron blocks, and slide in a dove-tail slot, locking separately, for the reason that *each and every one may be set and locked immediately*. This absolutely does away with any accidental moving of same, which may be caused in many ways. Again, should any die holder become worn by constant use, it can be safely locked with any number of other die holders that you may desire to use. This is a very important point.

All punches and dies are interchangeable. This machine will punch through one-half inch of paper. It will punch one or twenty holes at each operation, any size from $\frac{3}{8}$ inch down. Adjustable to any distance between holes from $1\frac{1}{4}$ inches upwards. Six round-hole punches and dies with each machine. Open-hole work, as used in loose-leaf ledgers, etc., can be done on this machine. Will admit a sheet of paper full 28 inches wide and any length. Built in one size only.

| | |
|---|----------|
| 28 inches, steam power ; net weight, 600 lbs. | \$250 00 |
| 28 inches, foot power ; net weight, 550 lbs. | 225 00 |

THE CHALLENGE BOOK STABBER.

For use on clamp of paper cutter. Needles can be set any distance apart within a space of seven inches, and stab one sheet to three-quarter-inch thick. Invaluable in any printing office.

It is especially handy in binding pamphlets of all descriptions, stenographers' note books, memo. tabs, receipts, order blanks, etc.—in fact, all kinds of check binding is easily, neatly and quickly done.

By reference to the illustration below it will be seen that the stabber is easily attached to the clamp of the cutter.

The comb-like piece in the illustration is the stripper, and is attached to the bed, of the paper cutter, acting as a stripper and a back gauge for the work.

Cheapest and most efficient device for the purpose made.

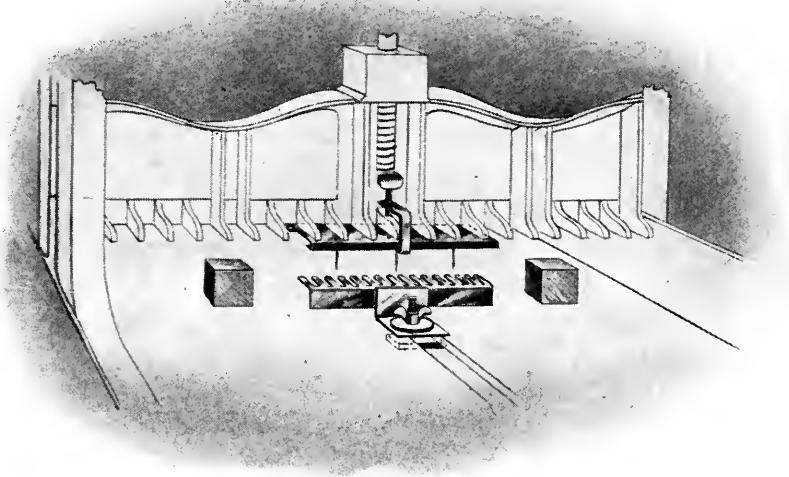

Challenge Book Stabber Adjusted on a Paper Cutter Ready for Use.

Price, complete \$4 00

HAND STABBING MACHINE.

For stabbing pamphlets, receipt books, etc., by hand or foot power. Built of iron, and made to fasten to a bench or table. The position of the needles can be easily and quickly changed, as they move laterally in a slot, and are held by set screws.

For hand power \$25 00
 For foot power 50 00
 Needles, per dozen 3 00



MULTIPLEX MONITOR PUNCHING MACHINE.

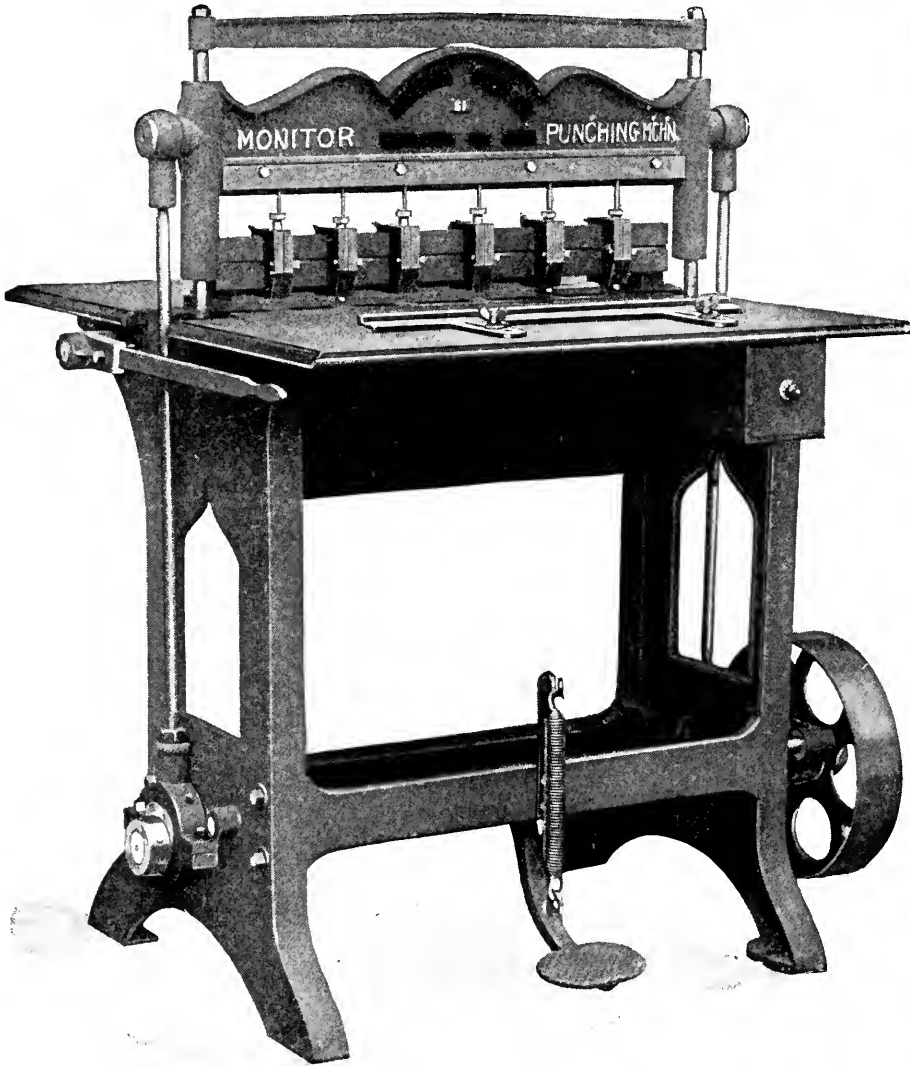

This latest improved Power Punching Machine, which is giving perfect satisfaction wherever used, is constructed on correct mechanical principles, and every detail has been thoroughly and carefully considered. The frame is very heavy, solid and substantial, and securely braced. The head, to which the male dies are attached, is held in position by two side rods, thereby insuring a true and perfect perpendicular motion. The punches travel through guides four and three-quarters inches in length, the punch passing through the guide a little to one side of its center, forming an eccentric by which the male die can be adjusted to accurately register with the female die and rigidly locked in the correct position. These guides can be set close to the paper, and act as strippers to remove the work from the punches.

Holes can be punched with this machine through about one-half inch of paper, making perfectly true and smooth perforations, which can be spaced from 1½ inches to 25 inches apart, and from one to twenty made at each operation.

Operating shaft below connects to head by side rods by means of a projecting hub, on which a collar of the side rod operates. This removes any possible lateral motion or strain to the head.

When ordering, give size of holes desired by number, from cut shown above. Dies furnished for loose-leaf ledgers or for special purposes at small additional cost.

Price, complete with six punches \$250 00
 Extra punches and dies, per set 2 50
 Net weight, 680 lbs. ; crated, 800 lbs.

No. 4 PUNCHING AND HAND EYELETTING MACHINE.

Can be used for Eyeletting by Hand by
Substituting Punches for Eyelet Sets.

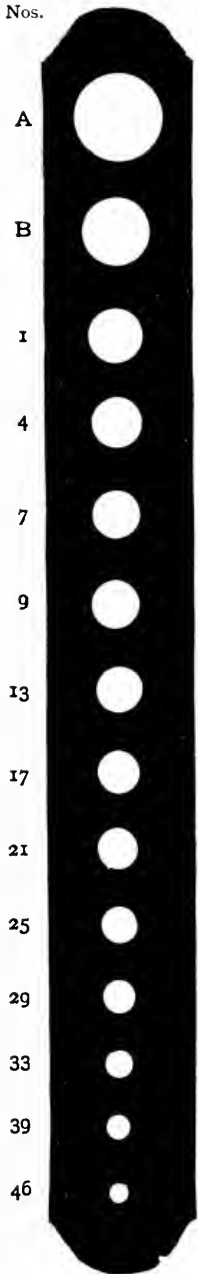

Punch and Die.

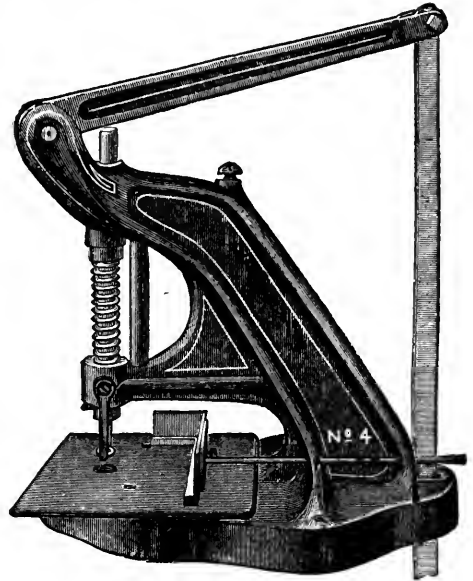

This is the proper machine to use with eyeletting machines shown on preceding pages. Except on cloth, good work cannot be done unless the hole is punched out *clean* before eyeletting. The No. 4 Machine will do work up to $\frac{3}{8}$ -inch diameter (No. 3 Calendar Eyelet) and has a reach of $6\frac{1}{2}$ inches back of plunger, and an adjustable gauge for all kinds of work.

By removing the punch and die and substituting an eyelet set, this machine may be used for eyeletting by hand feed, and will do perfect work.

| | |
|---|---------|
| No. 4 Punching Machine, with treadle, and one punch and die | \$20 00 |
| Extra punch and die, per pair | 2 50 |
| Eyelet set, per pair | 2 50 |

COMBINED EYELET PUNCH AND SET.

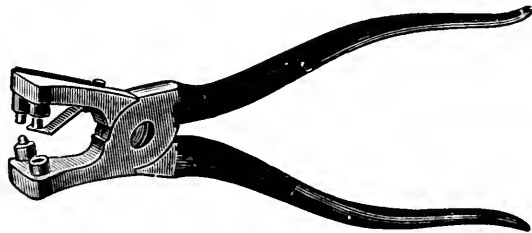

An indispensable tool in the printing office. Punches the hole and sets the eyelet. Takes only one size of eyelet (No. 2 Skirt).

| | |
|------------------------------------|--------|
| Price, complete | \$2 25 |
| Eyelets, per box of 1000 | 0 50 |

Sizes of punches and dies correspond with eyelets made. Order by number.

THE PETIT FOOT-POWER EYELETTING MACHINE.

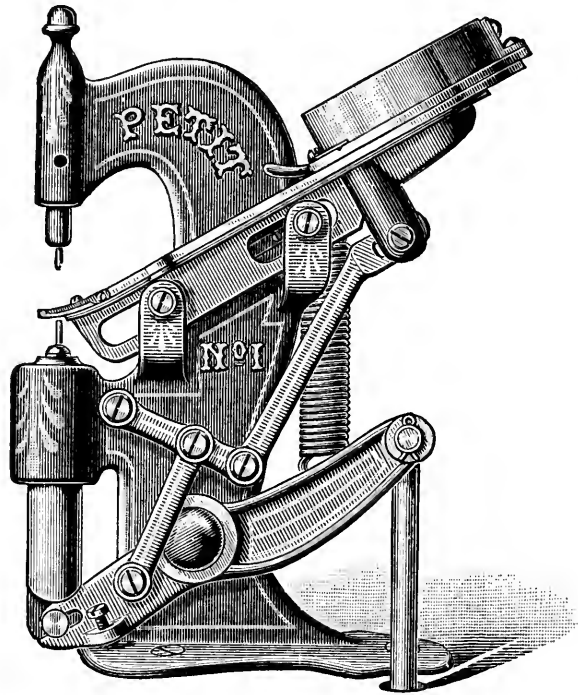

This is not recommended for the general work of printing offices and binderies, but is perfectly adapted to special work requiring eyelets not exceeding $\frac{3}{32}$ -inch inside, known as No. 1 "C. Z." It will take the smallest eyelet, $\frac{1}{16}$ -inch inside, known as "D. E."

It is a perfect feeding machine, 12 inches high, 9 inches deep, weighs only 17 pounds, and is very easy to operate.

| | |
|--|---------|
| No. 1. The Petit, with one roadway | \$30 00 |
| Extra roadways, each | 12 00 |

EYELETS.

The largest eyelet used is "No. 3 Calendar," smallest is "D. E.," $\frac{1}{16}$ -inch inside. The eyelets in most common use are "No. 3 Calendar" and "No. 2 Skirt" (as illustrated). The prices of eyelets in large quantities vary from time to time, and special quotations will be given when required.

Smallest quantity sold 10,000 in one box, except No. 3 Calendar, which are put up in boxes of 5000. They are also packed in bulk cases containing 250,000 of any size.

| | |
|---|--------|
| No. 3 calendar eyelets, per box of 5000 | \$3 75 |
| No. 2 skirt eyelets, per box of 10,000 | 4 50 |

Special quotations for larger quantities.

Sizes of Eyelets.

The cuts show exact sizes of each eyelet when set in the material eye-letted.

The heavy figures under cuts indicate the size of punch and die to be used with eye-lets.

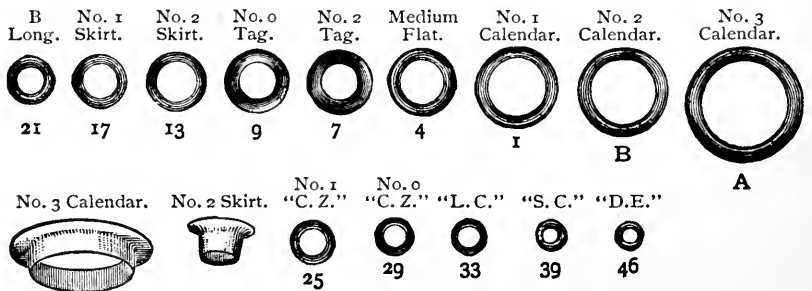

SELF-FEED FOOT POWER EYELETING MACHINES.

With Removable Roadways.

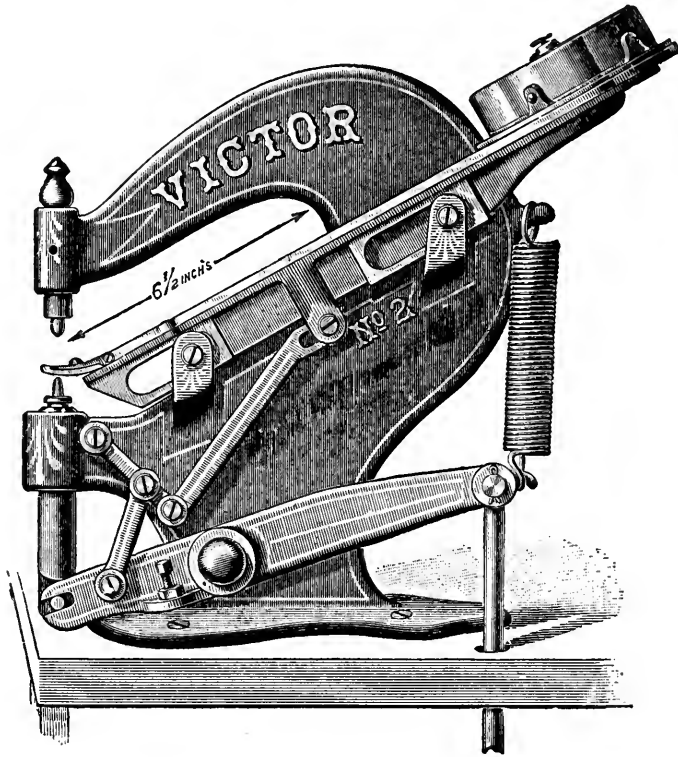

THE VICTOR.

Has a reach from eyelet set to back of arm of 6½ inches, and will set an eyelet in the center of a square 13×13 inches. Will set eyelets in paper, metal, leather, cloth, etc.

The eyelet roadway or feed channel is made to feed but one size eyelet; if other size eyelets are used on machine, an extra roadway is necessary. When ordering machine, specify by name the eyelet for which machine is to be fitted. If extra roadways are wanted, be particular to state the size of eyelet to be used. It takes only a few moments to change one roadway for another on machine.

The Victor is easy to operate, weighs 30 pounds, is 14 inches high, 15 inches deep, and is a perfect working machine and very durable.

| | |
|---|---------|
| No. 2. The Victor, with one roadway | \$40 00 |
| Extra roadways, each | 14 00 |
| Power attachments, extra | 40 00 |

In ordering, send samples of eyelets to be used, as the roadway will feed only one size of eyelet. An extra roadway is required for each size of eyelet.

THE ROYAL.

Differs from the No. 2 Victor in the reach only, which is 9 inches, setting eyelets in a square 18×18 inches.

It weighs 45 pounds, is 15 inches high, 16 inches deep, and is a perfect working and very durable machine.

| | |
|--|---------|
| No. 3. The Royal, with one roadway | \$45 00 |
| Extra roadways, each | 16 00 |
| Power attachments, extra | 40 00 |

In ordering, send sample of eyelet to be used, as the roadway will feed only one size of eyelet. An extra roadway is required for each size of eyelet.

**MONITOR EXTRA HEAVY PERFORATOR.
ROUND-HOLE—POWER.**

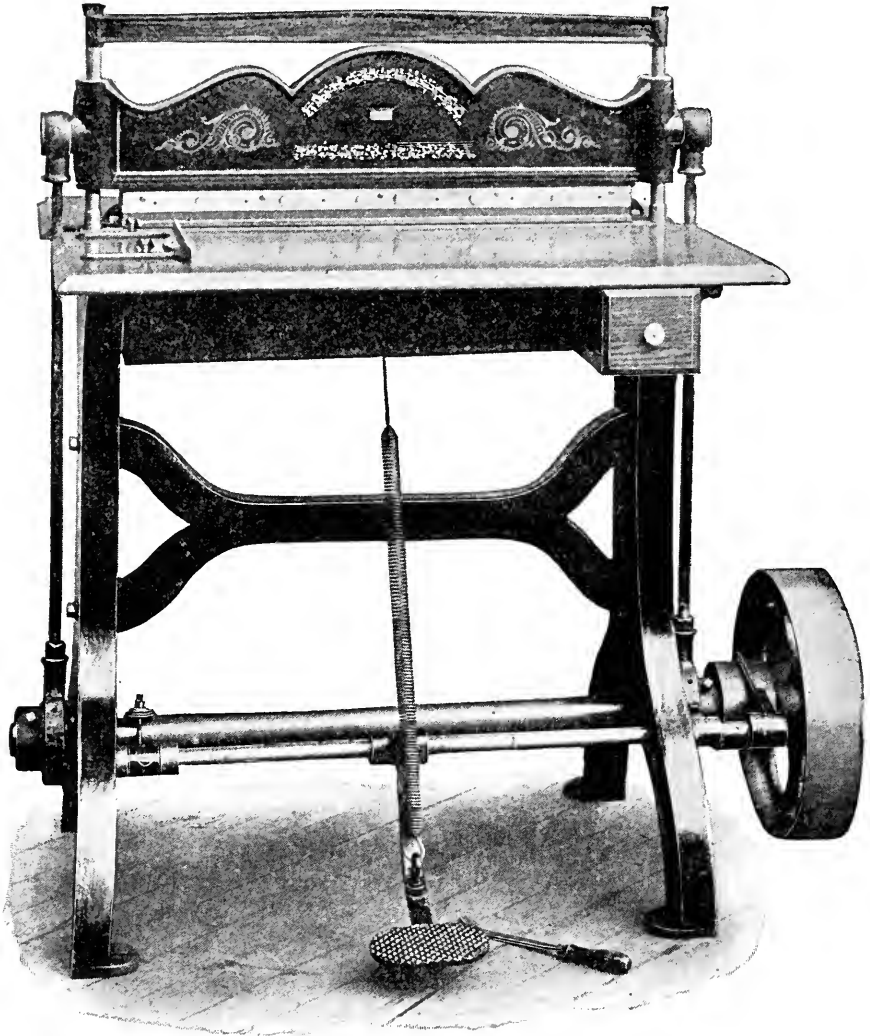

This Extra Heavy Perforator embodies those points which not only render it capable of doing the very highest grade of work, but which give it durability, thereby securing a minimum of wear.

This machine is massive and strong in its construction, securely braced, as can be seen by the illustration above. The side guides for the head are supported by a cross brace above the head, thereby insuring a true and perfect perpendicular motion. This supports the head so thoroughly that a portion of the machine can be used without displacement of any portion of the needle bar.

The head is connected with operating shaft below by side rods, which are joined to the head by means of a projecting hub, on which the collar of the side rod operates. This removes any possible lateral motion or strain to the perforator head.

The power pulley is large, affording an abundance of leverage for conveying the power.

| | |
|---|----------|
| 28-inch Power Perforator, extra heavy | \$275 00 |
| 24-inch Power Perforator, extra heavy | 250 00 |

Weight, net, 28-inch, 418 lbs. ; 24-inch, 380 lbs.

MONITOR FOOT-POWER ROUND-HOLE PERFORATORS.

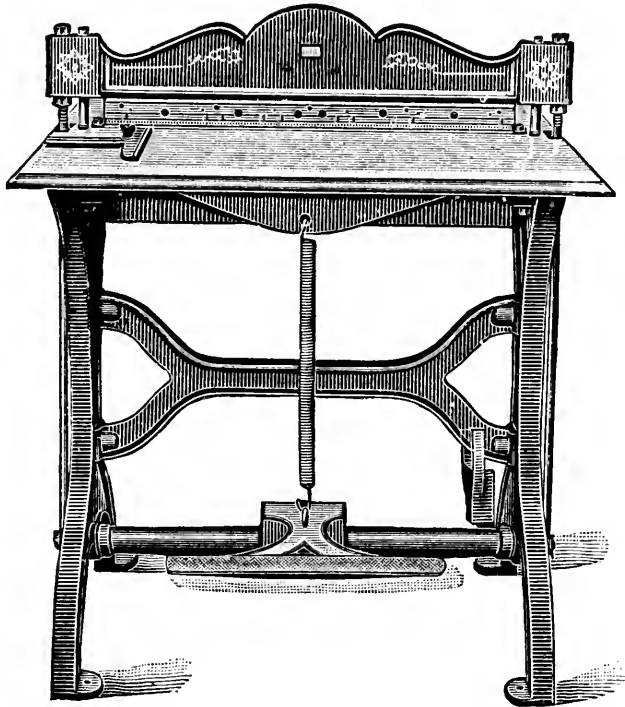

This machine makes a perfect perforation, and is durable. One of the chief points of improvement is the fact that the needles are directly under the center of the head, and in line with the side rods. This allows a perfect, even draw with the least possible wear of the pins, die and stripper.

Another important improvement is the stripper. As ordinarily made they are of a flat piece of brass that needs to be of moderate thickness. To obviate this, the same thickness of brass is used for stripper, attached to an angle bar, but it extends behind and two inches upward in the back, positively preventing any springing in the center of the stripper. There is also a bevel on the front edge of the stripper, which enables the operator to see the line of needles at all times before entering the paper.

The bed-plate on which the steel die is placed is made of sufficient weight to allow no spring under the dies.

| | |
|--|----------|
| 24-inch, foot power | \$100 00 |
| 28-inch, foot power | 125 00 |
| Weight, net, 28-inch, 340 lbs. ; 24-inch, 318 lbs. Guaranteed. | |

**GEM TREADLE PERFORATOR.
Made in Four Sizes.**

This machine is made of the best material, has hardened and tempered steel dies, and the perforations are round, as on postage stamps. Needles bent by accident or otherwise can be removed very easily and others inserted, as they are all independent of each other.

One hundred extra needles, one pair of pliers, one screw driver, one file for sharpening needles, and directions for operating, sent with each machine.

| | |
|--------------------------------------|---------|
| Gem, perforates 15 inches | \$40 00 |
| Gem, perforates 20 inches | 50 00 |
| Gem, perforates 24 inches | 60 00 |
| Gem, perforates 28 inches | 70 00 |
| Extra needles, per hundred | 0 50 |

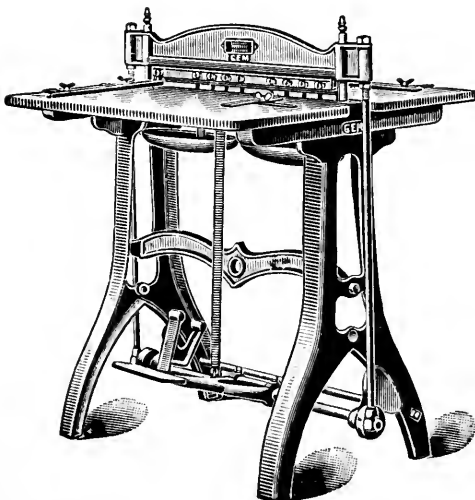

THE ROSBACK POWER PERFORATOR.

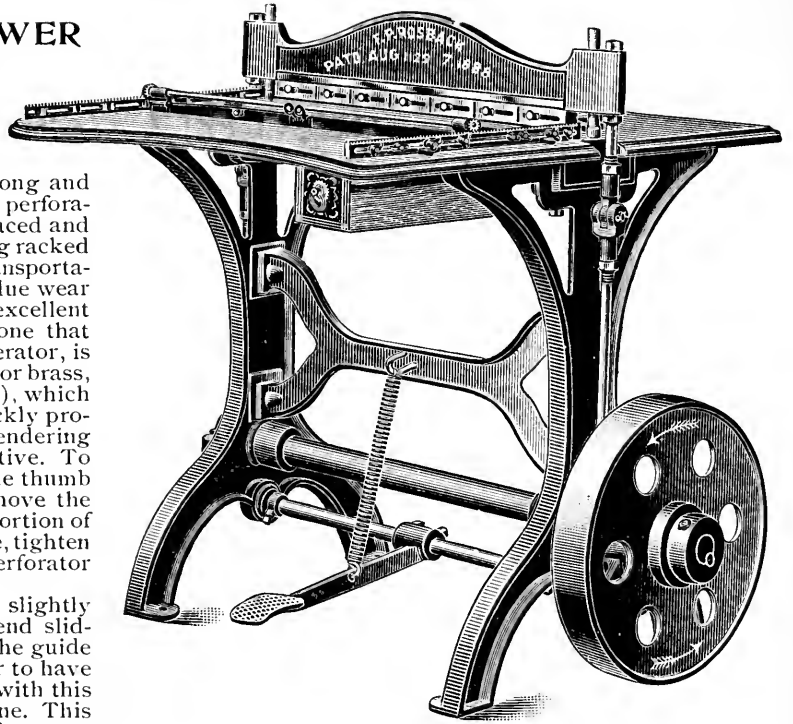

This machine is built strong and durable, and makes a perfect perforation. The frame is securely braced and bolted, so as to prevent its being racked or twisted out of shape by transportation or otherwise, causing undue wear on the needles and die. A very excellent feature of this machine, and one that will be appreciated by the operator, is the sliding slotted plates, steel or brass, on front of needle-bar (see cut), which enables him to easily and quickly provide for stubs of checks, etc., rendering a portion of the needles inoperative. To do this, he has but to loosen the thumb screws on the sliding plates, move the plates to a position over that portion of the paper he wishes to perforate, tighten the thumb screws, and the perforator is ready for work.

The needles are thrown slightly off center, in order that the end sliding plate may extend beyond the guide pin, thus enabling the operator to have the same length of adjustment with this point has been overlooked in every other make. The stripper has a heavy flanged back, consequently is stiff and will not spring. The bed on which the die plate is fastened is about one-half inch thick, thus insuring a solid cutting surface.

PRICES.

| | Weight. | With P. & P. Feed Gauge. | Without P. & P. Feed Gauge. |
|----------------------------------|------------------|--------------------------|-----------------------------|
| 28 inches, steam power | 425 lbs. | \$210 00 | \$175 00 |
| 24 inches, steam power | 375 lbs. | 185 00 | 150 00 |
| 20 inches, steam power | 325 lbs. | 160 00 | 125 00 |

THE "PROGRESS" EXTRA HEAVY PERFORATOR.

Same pattern as above illustration, but heavier. Has same points of superiority, and with the addition of the feed-gauge device, shown in cut, has a reclining rear table and jogging gauges. Made in one size and for steam power only.

28-inch "Progress" Extra Heavy Perforator, with P. & P. Feed Gauge and reclining rear table with jogging gauges complete; weight, 500 lbs.; power . . \$325 00

THE ROSBACK FOOT-POWER PERFORATORS.

Same pattern, and with all improvements of steam-power machine.

| | Weight. | With Feed Gauge. | Without Feed Gauge. |
|---------------------|------------------|------------------|---------------------|
| 28 inches | 400 lbs. | \$160 00 | \$125 00 |
| 24 inches | 350 lbs. | 135 00 | 100 00 |
| 20 inches | 285 lbs. | 110 00 | 75 00 |

P. & P. PATENT FEED GAUGE.

For any round-hole perforator \$35 00

In ordering this gauge, please state size of your perforator.

ROSBACK HAND PERFORATOR.

This perforator, as is seen in the cut, is a strong and durable machine, and is thoroughly guaranteed as such. It perforates full ten inches, and by turning the sheet makes a perforation of twenty inches across the sheet. It makes a round hole—fifteen to the inch.

The springs are incased in the body of the machine near either end of the needle bar, thereby preventing the bar from tilting or tipping.

The stripper is double-flanged, which renders it stiff and firm, and not liable to spring or careen.

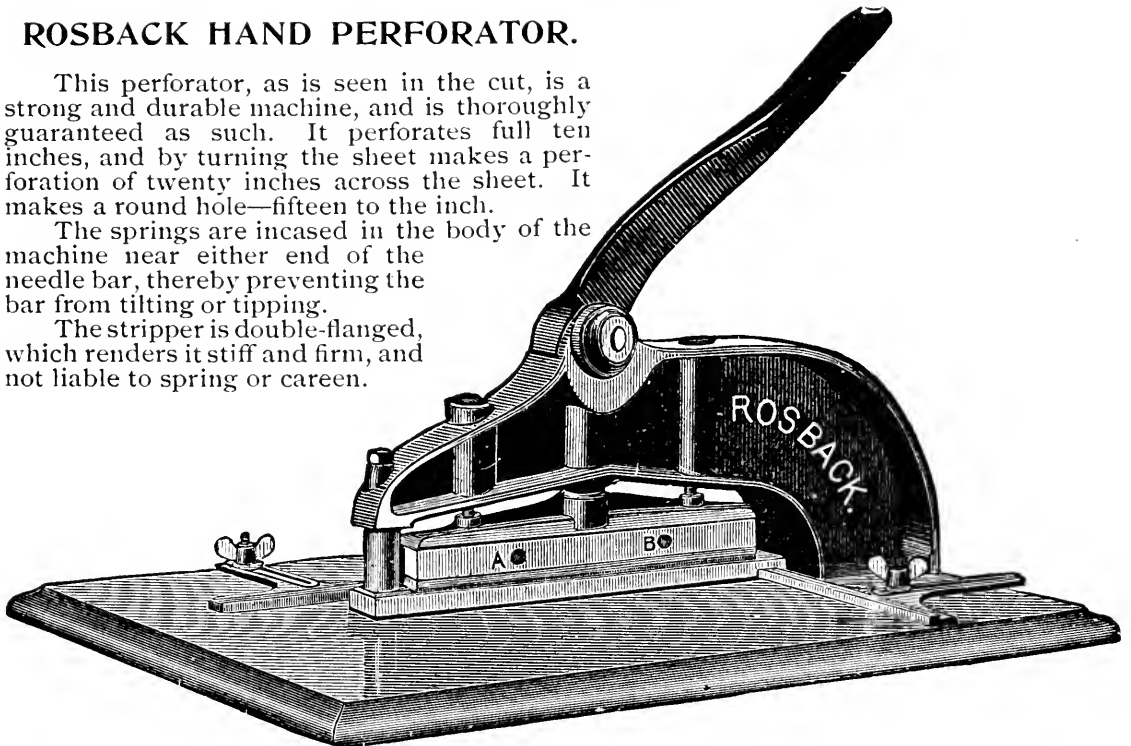

A needle accidentally bent can be removed and another inserted in its place by simply removing the screws A and B, and detaching the needle stop, removing the defective needle and replacing it with a new one—the whole operation requiring but a few minutes' time. In like manner any number of needles can be easily removed so as to perforate any length from 1 to 10 inches. This feature will particularly recommend it to those who know by experience how much time and patience are required to replace defective needles in cheaper machines.

Hand Perforator, 10 inches ; net weight, 65 lbs. \$35 00

FRANKLIN HAND PERFORATOR.

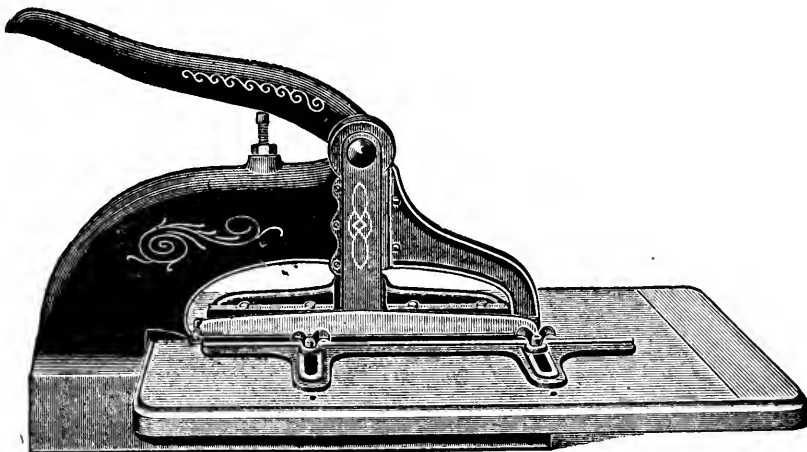

Perforates ten inches, and is provided with gauges on both sides, so that the sheets may be turned and fed in again, making a continuous perforated line of twenty inches. The pins make round holes, like the perforations on a sheet of postage stamps. Fifteen holes to an inch.

Hand Perforator, 10 inches \$25 00

HAND EMBOSSING PRESS.

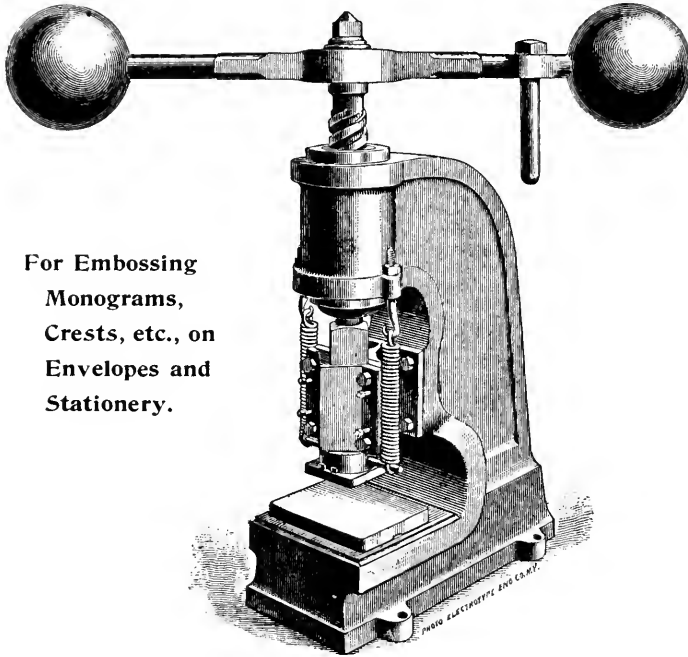

**For Embossing
Monograms,
Crests, etc., on
Envelopes and
Stationery.**

Embossed work on envelopes, note paper, menus, and other fine stationery, is the most stylish form of printing. The process is simple. Dies cost from \$1.00 to \$5.00, according to elaboration of design. Dies are made of steel. The counter is usually made of bristol board, thin rubber cloth and thin paper, and is fastened to bed-plate with glue or gum arabic. The inks are made from dry colors, mixed with white damar varnish. The ink is smeared over the die, and the face of the die is cleaned of ink, and polished by rubbing on paper. Bronzed effects are obtained by embossing with varnish instead of ink, and dusting on the bronze; superfluous bronze is taken off by dusting with a brush. Any printer can do this work, and thus add a lucrative department to the business.

This press is the best made, and is used by all the leading houses.

| | |
|---|---------|
| Large press, with one die-box and counter | \$75 00 |
| Small press, with one die-box and counter | 60 00 |
| Extra die-boxes, each | 4 00 |
| Extra counters, each | 3 00 |

Weight of large press is 335 lbs.; of small press, 190 lbs. Boxing, \$1.50, net.

Those who have use for one press are advised to purchase the large size, as the other will only take small dies. Largest die taken on large press, 5×4 inches; on small press, 4×3 inches.

FAST GOLD LEAF LETTERING AND STAMPING PRESSES.

Made in two styles. No. 1, illustrated here, is the best press of its kind for small stamping or embossing. Size of platen, 12×12 inches; size of head, 11×11 inches. The wheel at top carries the screw that raises or lowers the head, and the set screw at front binds it firmly. Can be supplied with 19¼ or 26 inches between uprights.

Three stamp-holders, varying sizes; one large chase, one large and one small plate for electros and brass work, one atmospheric gas heater, set of band holders, and assortment of steel fillers for chase, go with each machine.

The No. 2 press, for gas, gasoline or steam, is especially recommended for printing badges. In this press the bed does not slide, and the platen is raised or lowered by screws set in the side frames. Size of head, 12×12 inches; size of platen, 13½×13½ inches. Takes work 14 inches wide and any length.

The head will allow a change of six inches in thickness. One type-holder with chase, two plates for electros, one set of fillers, and an atmospheric gas heater go with each machine.

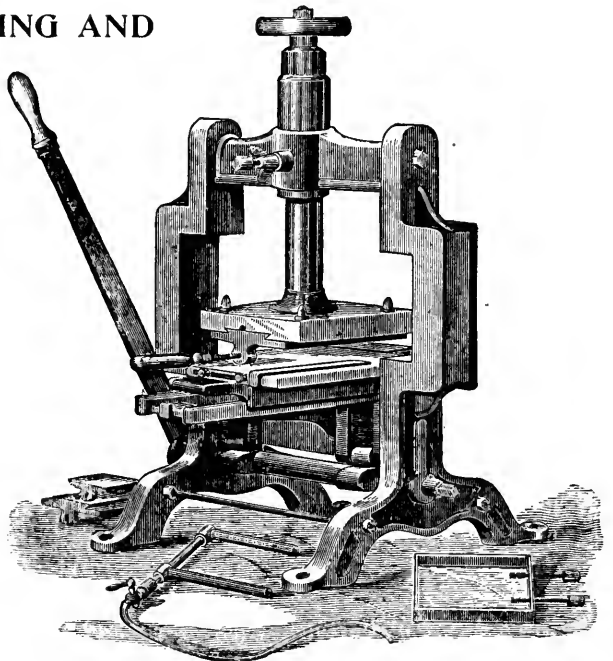

No. 1 Stamping and Embossing Press, for Steam, Gas or Gasoline.

No. 1, complete, as described . . \$150 00 | No. 2, complete, as described . . . \$75 00

Catalogue of Embossing Dies sent on receipt of 25 cents.

STANDING PRESSES.

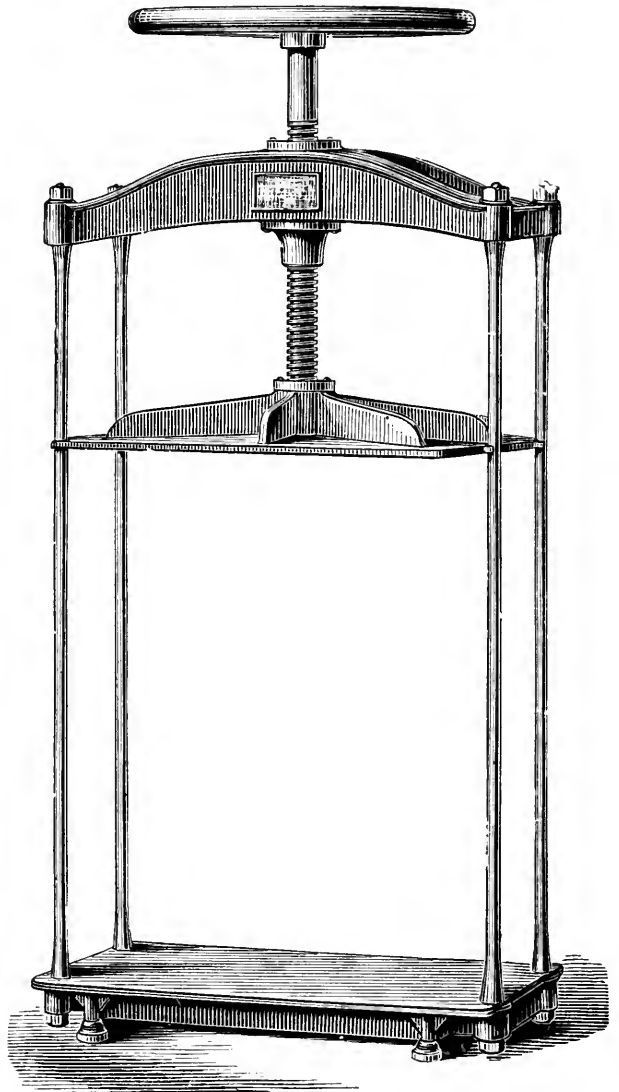
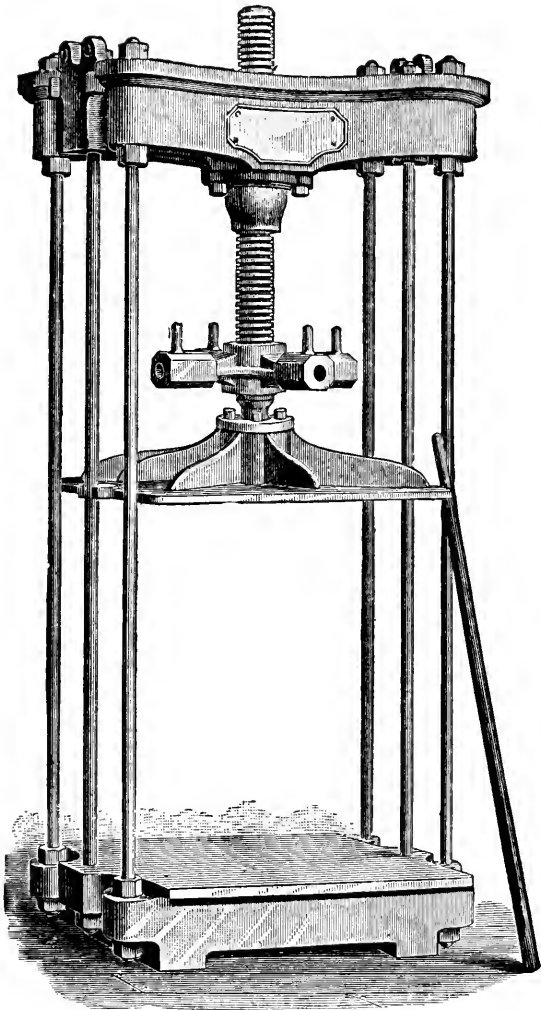

Illustrates Standing Presses Nos. 5 and 6, operated with spider and lever.

Illustrates Standing Press, No. 4, with hand wheel at top. No. 3 is same press except that it is operated with spider and lever.

These presses are very strong throughout—in top, base and platen.

No. 2 has two rods, and opens seven inches between bed and platen.

No. 3 has four rods, and opens thirty-seven inches.

No. 4 has four rods, and opens thirty-seven inches.

The Nos. 5 and 6 sizes have six wrought iron rods $1\frac{1}{4}$ inches in diameter. The boxes for main screws are phosphor bronze. The No. 5 opens forty-six inches, and No. 6 opens forty-eight inches. The screw is of $\frac{3}{4}$ -inch steel, and is made all in one piece.

| | |
|---|---------|
| No. 2.—Size 10×16, operated by hand wheel at top, as shown in cut | \$25 00 |
| No. 3.—Size 16×24, operated by a spider and lever | 60 00 |
| No. 4.—Size 16×24, operated by hand wheel at top | 50 00 |
| No. 5.—Size 20×28½, operated by a spider and lever, as shown in cut | 110 00 |
| No. 5A.—With pawl | 125 00 |
| No. 6.—Size 21×29, operated by a spider and lever | 130 00 |
| No. 6A.—With pawl | 140 00 |

Boxing extra.

STYLE 1-A HICKOK HAND STRIKER RULING MACHINE.

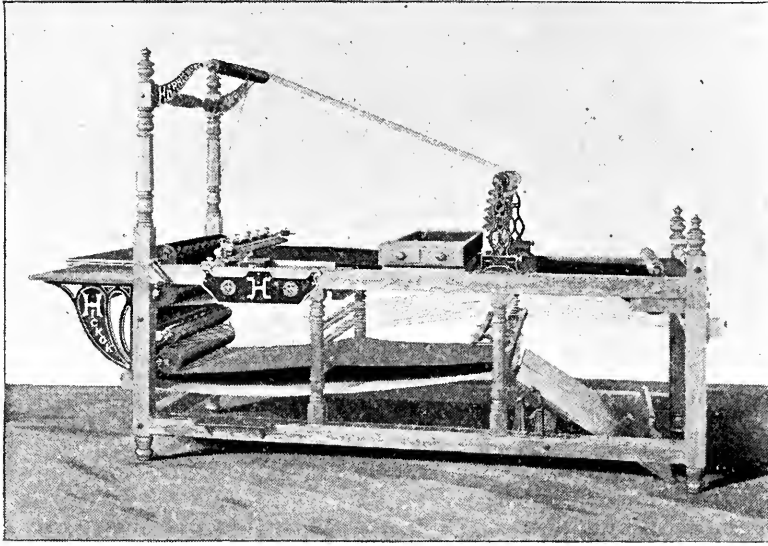

STYLE 1-A Ruling Machine is for use in shops where there is considerable faint or cross ruling, thus economizing the time of automatic strikers used in the same shop. It may also be used in small-sized binderies, where there is not sufficient work for an automatic striker machine. The operator turns the hand crank with the left hand, thus operating the machine by hand, while with the right hand the pen-beam is tilted up and down, doing hand striking. Power may be applied, and steam attachments are furnished to order at an extra charge. Style 1-A is as perfectly built in every part as the most expensive automatic striker ruling machine. The difference in construction is simply leaving off the striker parts and some other necessary pieces required on an automatic striker machine.

STYLE 1 SINGLE BEAM AUTOMATIC STRIKER RULING MACHINE.

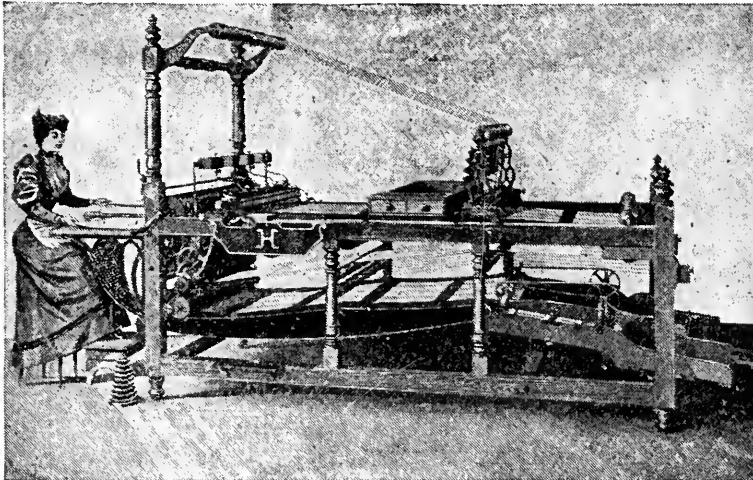

STYLE 1 is used for faint or cross-lining when the striker is not operated, and also for down ruling from cross or head lines when the automatic striker is used for the purpose of leaving unruled head spaces by automatically raising the pens from the paper and allowing them again to descend upon the paper, the pens beginning to rule immediately upon touching the paper at a cross head line, and again being automatically raised from the

paper and lowered upon the paper again successively at distances prearranged by the positions of the cams, which are adjusted by the operator, who sets them in the circular-revolving cam-head. This machine is for use on all classes of job ruling.

The illustration shows the combined lay-boy and receiver—a device for receiving the paper (after it is ruled) in the lower portion of the machine. Gears are used in setting the striker—friction devices being avoided because gears are more positive in the correct delivery of both speed and power.

For prices, see next page.

STYLE 1 HICKOK "SINGLE" O-A STRIKER RULING MACHINE.

Having One Patent O-A Automatic Striker Beam.

This machine has ample capacity for the ordinary bindery, and is absolutely complete. The "Duplex" and "Triple" strikers simply add to the capacity, but are not superior in workmanship.

Suggestions.—The style 1 O-A is an excellent machine for the shop having considerable work to be faint-lined and "struck" or "down-lined," and for classes of work where the "striking" is not intricate or from many different head-lines.

Width.—Every machine, where width is not specified in order, will be considered 38 inches between rails. Please specify, however, width clearly in all cases.

Guide-Board.—Unless otherwise specified, guide-boards will be placed on the left side. Please specify, however, the sides in each case.

Furnished Without Extra Charge.—Our new patent "self-locking" O-A angle standards, supplied with the lateral and vertical adjustment; cloth guide; four 32-inch and two 26½-inch clamps (longer clamps on wide machines); set of cams; nest of change gears; ink fountains, with double faucets and carrier rod; right-angle screw adjustment for gate; new style lightning-action gate; adjustable steel cam-plate on pen-rest; foot-rest on lower rail; steam-fixtures; double cone-pulley, giving many different speeds; new elevated string-roll and clamp-rack combined; our new steel adjustable guide, attached to guide-board; change gears on side of machine opposite the ruler; ink-box, with drawer.

STYLE 3 HICKOK "DUPLEX" O-A STRIKER RULING MACHINE.

Having Two Patent O-A Automatic Striker Beams.

This ruling machine, as its name indicates, is the same as the single O-A striker in all respects, but in addition has a second striker beam, or auxiliary striker, with all the necessary parts for tilting the beams and striking automatically at desired points, thus enabling the operator, by manipulating both beams, to strike down-lines from twice the number of distinct head-lines as with the single-beam machines, and to rule with more colors at a time without danger of their mixing, etc.

38-inch machines, boxed, weigh about 1200 pounds.

STYLE 1-A HICKOK RULING MACHINE.

For Faint-Line Ruling or Striking by Hand.

| | | | | | | |
|-----------------------------------|-----------------|------------|------------|------------|------------|------------|
| | BETWEEN RAILS : | 38 inches. | 42 inches. | 44 inches. | 48 inches. | 54 inches. |
| | CLOTH : | 32 inches. | 36 inches. | 38 inches. | 42 inches. | 48 inches. |
| With improved receiving box . . . | \$235 00 | \$275 00 | \$285 00 | \$305 00 | \$335 00 | \$335 00 |
| With No. 1½ lay-boy | 260 00 | 305 00 | 315 00 | 335 00 | 365 00 | 365 00 |

STYLE 1 O-A AUTOMATIC.

Single Beam Striker.

| | | | | | | |
|-------------------------------|-----------------|------------|------------|------------|------------|------------|
| | BETWEEN RAILS : | 38 inches. | 42 inches. | 44 inches. | 48 inches. | 54 inches. |
| | CLOTH : | 32 inches. | 36 inches. | 38 inches. | 42 inches. | 48 inches. |
| With receiving-box | \$410 00 | \$450 00 | \$460 00 | \$480 00 | \$510 00 | \$510 00 |
| With No. 1½ lay-boy | 435 00 | 480 00 | 490 00 | 510 00 | 540 00 | 540 00 |
| With No. 2 lay-boy | 450 00 | 495 00 | 505 00 | 525 00 | 555 00 | 555 00 |

STYLE 3 O-A "DUPLEX."

Automatic Two-beam Striker.

| | | | | | | |
|-------------------------------|-----------------|------------|------------|------------|------------|------------|
| | BETWEEN RAILS : | 38 inches. | 42 inches. | 44 inches. | 48 inches. | 54 inches. |
| | CLOTH : | 32 inches. | 36 inches. | 38 inches. | 42 inches. | 48 inches. |
| With receiving-box | \$485 00 | \$525 00 | \$535 00 | \$555 00 | \$585 00 | \$585 00 |
| With No. 1½ lay-boy | 510 00 | 555 00 | 565 00 | 585 00 | 615 00 | 615 00 |
| With No. 2 lay-boy | 525 00 | 570 00 | 580 00 | 600 00 | 630 00 | 630 00 |

RULING PENS ON POINT SYSTEM.

Made to adjust with point system of type bodies of the American Type Founders' Co. Length of bars, 4¼ inches; six bars in a set. The number of pens on a bar can be calculated by any one familiar with point system of type bodies. Faint-line pens sold only in sets.

| | |
|--|----------|
| Faint-line pens, in bars (combs), from 7 point to 36 point, each pen | \$0 01 ½ |
| Regular down-line pens (striker pens), singles, and No. 9 double, each pen . . . | 0 02 |
| Regular down-line pens, triples, each pen | 0 02 ½ |
| Extra long down-line pens (shanghai), singles, doubles, and triples, each pen . . | 0 03 |
| Extension pens, soldered on brass, singles, doubles, and triples, each pen . . . | 0 03 ¾ |
| Extension pens, soldered on tin, singles, doubles, and triples, each pen | 0 02 ½ |

UNIVERSAL SAWING MACHINE.

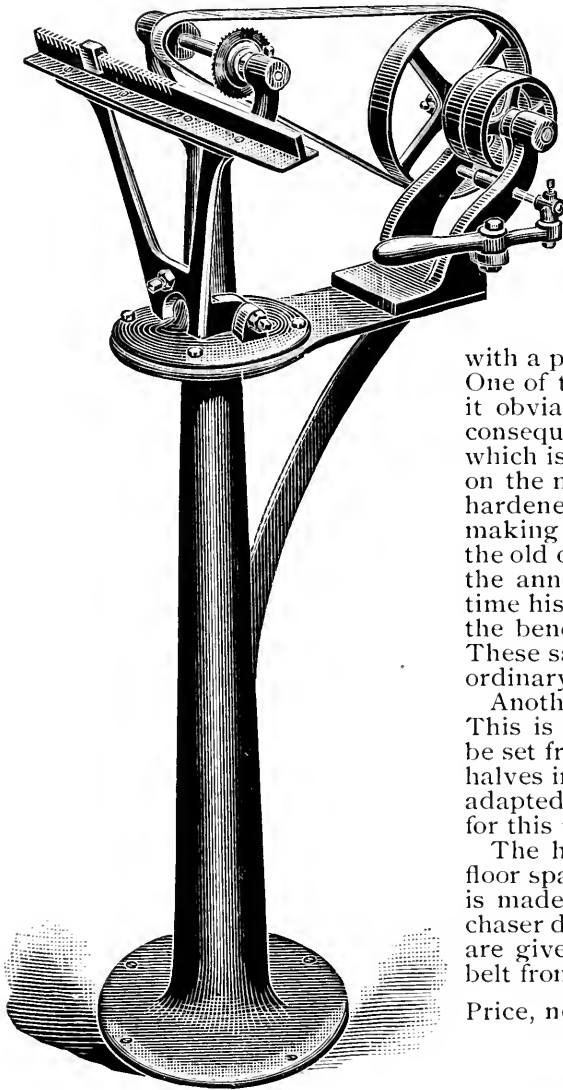

This machine fills all the requirements of an accurate, speedy and durable tool. It is simplicity itself, and anyone without previous experience can handle it with ease. It was designed to meet the growing demand of the printer for a thoroughly reliable machine, at a reasonable price, to accurately cut brass rule, leads, slugs, reglet, etc. It is constructed with exceptional care, and has very few working parts and wearing surfaces, all of which are made of the best hardened tool steel. It will saw thick or thin brass rule accurately to absolute type measurements,

with a perfectly square edge and clear, sharp face. One of the special features of the machine is, that it obviates the use of a saw of larger diameter, consequently its work has that degree of accuracy which is not attained by any other sawing machine on the market. It uses a small, rigid, true-ground, hardened steel saw, furnished at 20 cents each, making it cheaper to use a new saw than to have the old one sharpened. This also saves the printer the annoyance and expense of sending out every time his saw needs to be sharpened, and gives him the benefit of a new saw each time for his work. These saws are vastly superior in every way to the ordinary saws now in use.

Another feature of this machine is its gauge. This is made accurately to type measure, and can be set from one-half to fifty Picas, including all the halves in this measure. The Universal is also well adapted for sawing linotype work. Special saws for this work furnished at \$1.00 each.

The height of the machine is 48 inches, and the floor space occupied is 18x24 inches. The machine is made to belt from above or below, as the purchaser desires, but if no instructions upon this point are given, the machine will, in all cases, be sent to belt from above.

Price, net \$30 00

**CHALLENGE
TYPE-HIGH
MACHINE.**

The only device on the market, at a moderate price, that will reduce cuts to type-high, and make them true and even, when they have become warped from any cause. Passing all cuts, or plates mounted on wood, through this machine before the form is sent to press saves one-half the time usually spent in make-ready.

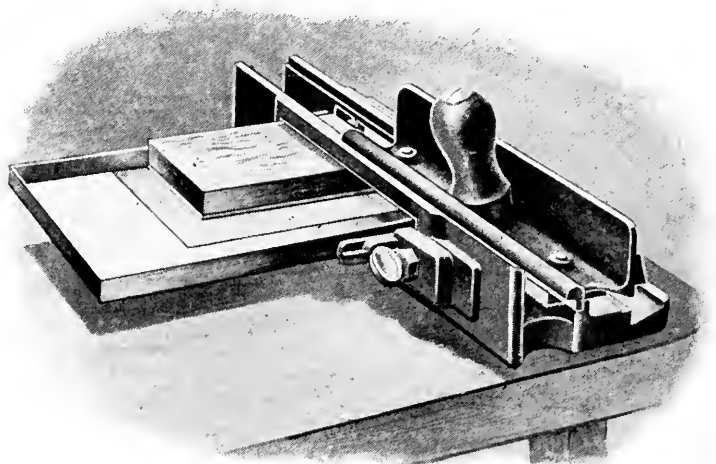

Challenge Type-High Machine, will galley 8x12 inches \$12 00
 Extra Files for Challenge Type-High Machine, each 0 75

PRINTERS' SAW TABLE,

With Shoot-Board Attached.

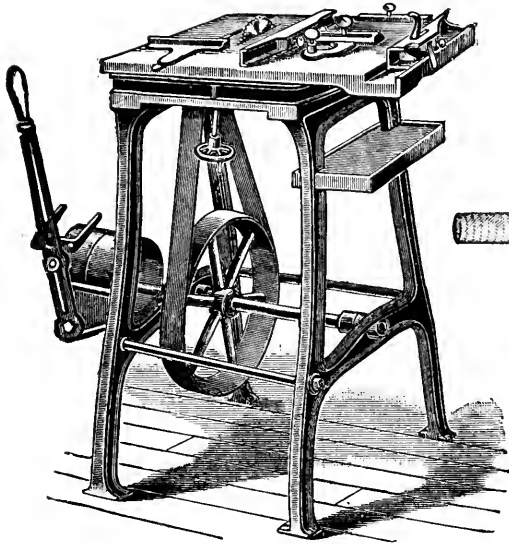

A very necessary machine in large printing offices. It will saw wood, metal or brass, and will trim wood and metal accurately from the merest shave upward. It affords the quickest and most accurate method of cutting slugs, furniture, thick brass rule and

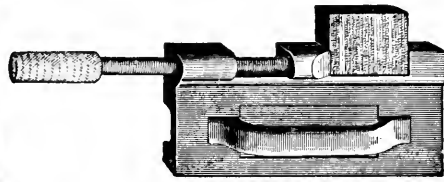

Attachment for Cutting Linotype Slugs.

plates, and as it is fitted in the most complete manner with gauges, all trimming and cutting is done with perfect trueness and squareness. An at-

tachment for sawing linotype slugs is furnished for \$15.00 extra.

This is a thoroughly well-built machine, equal to similar machines used by electrotypers, made of iron and steel, with accurate adjustable gauges. The saw is raised or

lowered by means of a clamp-screw set under the table. The countershaft is attached to the saw, and should not run less than four hundred revolutions per minute. The driving pulley is 7 inches in diameter, for 2½-inch belt. Size of table is 18×24 inches, height 40 inches, and floor space occupied 24×32 inches.

| | |
|--|---------|
| Saw table with shoot-board | \$85 00 |
| Saw table without shoot-board | 70 00 |
| No. 1. Attachment for sawing linotype slugs, extra | 15 00 |
| No. 2. Attachment for sawing linotype slugs, for quick work, extra | 25 00 |

COMBINATION SHUTEBOARD AND TYPE-HIGH MACHINE.

This machine will take blocks of ten inches wide and any length. The carriage or guide frame for plane being movable from side to side while operating, blocks of the full width of the bed can be shaved at one locking. The cuts or plates are laid face downward on the bed, locked, and then shaved until the knife or file cuts no more, when they will be even type-high. If blocks are too low, lay sheets of paper or cards below them to raise high enough for shaving, and afterwards glue these sheets to bottom of cut, or place them between plate and wood.

Patented,
January, 1894;
December, 1895.

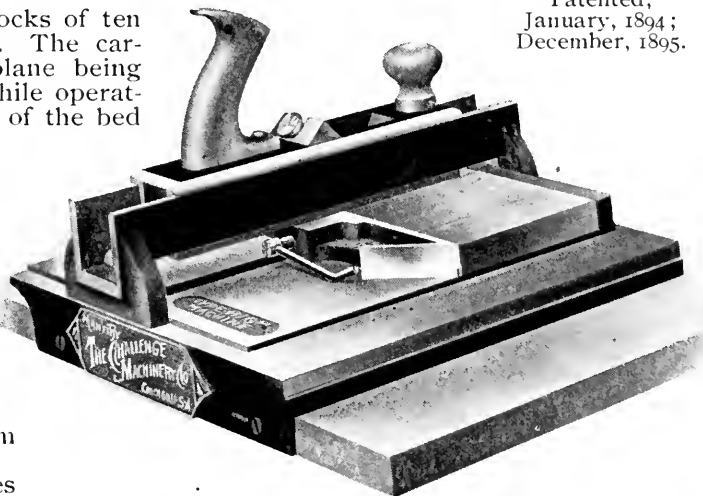

Three machines in one—Combination Shuteboard, Type-High Planer, Shaver and Miter Cutter.

For trimming slugs, rules or furniture (wood or metal of any size), cutting miters and squaring the sides of blocks, the guide frame is taken off and the plane used upon the side of the bed. It can be used as a bench vise, being handy for holding blocks when you want to take off or put on an electrotype plate. For warped blocks, the plates should be taken off, both top and bottom shaved and the plate remounted.

| | |
|---|---------|
| Complete, with two planes (one file plane, one knife plane) | \$25 00 |
| Extra files, each | 0 75 |

THE HORTON MAILER.

THE BEST MAILER ON THE MARKET.

Patented
May 1, 1894
May 9, 1899

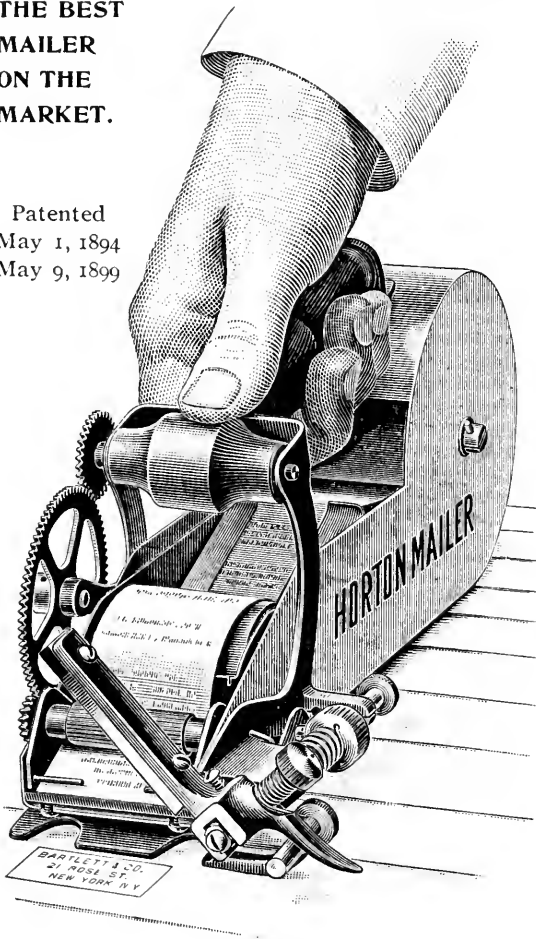

This is the best label-pasting mailer. It is quicker and more exact, because all its movements are positive. It is so simple that it can be worked rapidly and efficiently by the inexpert, while experts have addressed with it at the rate of 170 per minute. It is operated, as illustrated, by one hand, leaving the other entirely free to manipulate the papers or wrappers.

It guides and thoroughly pastes the slip, scrapes off all surplus paste, and sticks the label cleanly and firmly. The knives are thin and adjustable, with two cutting surfaces, and can be easily sharpened. The arrangements for adjusting knives with each other and regulating tension of knives are very exact.

It is very strongly made, and is the most durable of mailers.

When ordering mailer, don't forget to give width of mailing slip.

Slip guides furnished from 1 1/8 to 1 7/8 inches; taking all widths of mailing lists, not exceeding 10 1/2 Picas.

Price, with paste strainer, extra knives, screw driver and oil can, packed in a strong wooden box, net \$20 00

MUSTANG MAILER.

This mailer prints directly on the paper or envelope. The platen and its frame moves automatically, printing one address at a time. It will print three-line (8 point) addresses.

The Mustang Mailer occupies a space of 37 inches in length and 4 1/2 inches in width, and is made wholly of iron without springs or complications of any kind.

Speed is regulated solely by the speed of operator in passing the papers to and from the mailer. The mail list is made up in galleys ten ems Pica wide on the inside.

Each galley holds seventy-five addresses. The weight of the machine is fifteen pounds, and of the galleys one pound.

Price \$10 00

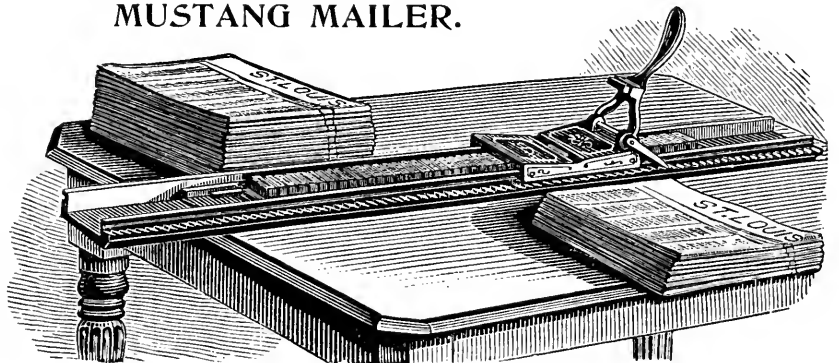

MUSTANG MAILING GALLEY.



Zinc bottom \$0 50
Brass bottom 0 75

THE ACME MAILER.

A good low-priced mailer, of which a great many are in use. It is built on the same lines as most of highest-priced mailers.

Price, net \$15 00

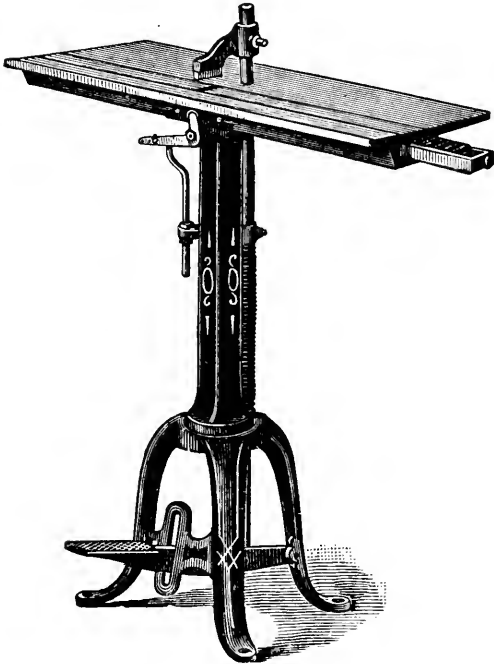

McFatrigh Mailing Machine.

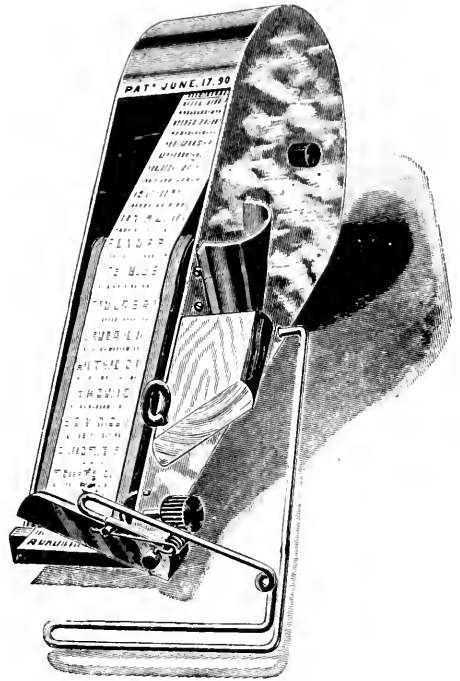

The Acme Mailer.

McFATRICH MAILING MACHINE.

Operated by treadle, leaving both hands free to handle the publication. Prints directly on the publication or the wrapper from type on galleys. The galley holding the addresses is moved one address at a time automatically. Speed from 2000 to 3000 per hour.

| | |
|---|---------|
| Machine for address 10 Picas wide | \$25 00 |
| Machine for address 14 Picas wide | 40 00 |
| Galleys, 10 Picas wide, 29 inches long, each | 0 80 |
| Galleys, 14 Picas wide, 30 inches long, each | 1 00 |
| Wood Reglet, 10 point, per 100, 10 Picas | 0 25 |
| Wood Reglet, 10 point, per 100, 14 Picas | 0 35 |
| Metal Slugs, 10 point, per 100, 10 Picas | 1 00 |
| Metal Slugs, 10 point, per 100, 14 Picas | 1 40 |
| Bell Slugs, zinc, 10 point, per dozen, 10 Picas | 0 50 |
| Bell Slugs, zinc, 10 point, per dozen, 14 Picas | 0 75 |

ECONOMY WRAPPER PASTER.

The paste fountain has a perforated bottom through which the paste reaches the top sheet of a pile, which may contain four hundred sheets. As the top sheet is drawn off, the next is pasted automatically and instantly, and so on. Wrappers are pasted as fast they can be drawn from the pile.

| | |
|--|--------|
| No. 10. For width of 10 inches or less, each | \$4 00 |
| No. 14. For width of 14 inches or less, each | 4 50 |
| No. 16. For width of 16 inches or less, each | 5 00 |

Patent applied for.

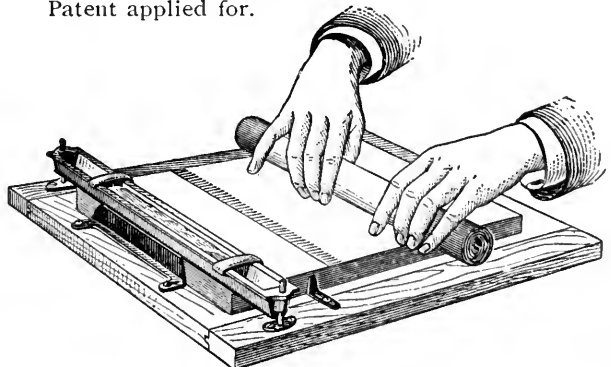

AMERICAN LEAD AND RULE CUTTER No. 3.

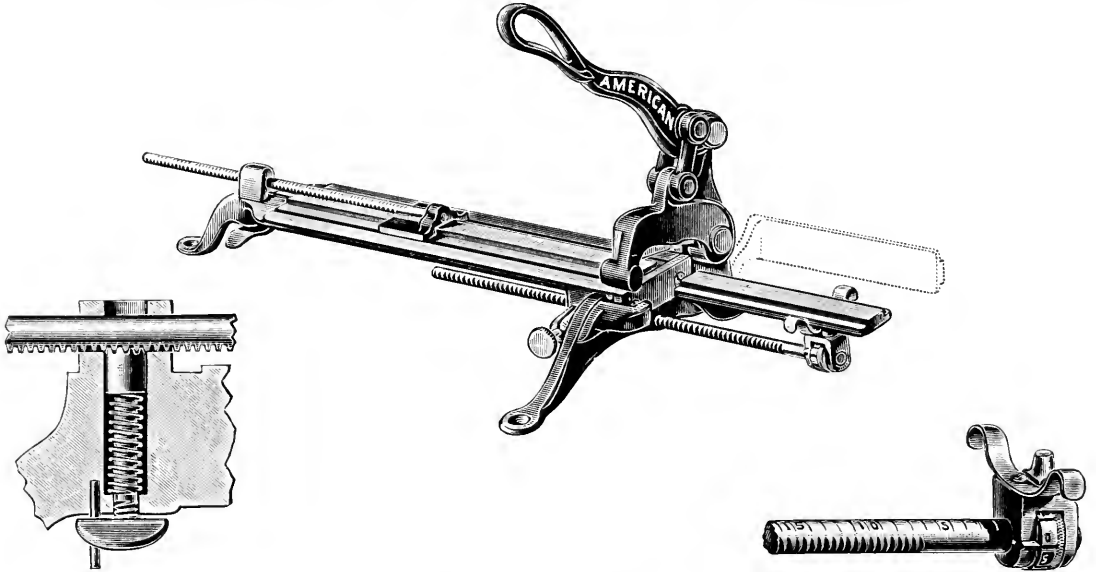

Gauge Lock.

WHY IT IS THE BEST.

Micrometer Gauge.

The gauges can be set instantly. They are absolutely positive. They are accurate, and guaranteed to remain so. They can be set to Nonpareils as well as Picas. The front gauge can also be set quickly and positively from one point to forty-eight Picas by points. It is impossible for either gauge to slip, or for material, however thin, to get under the bed gauge. The bed and gauge rods are graduated to Picas and numbered every five ems, the back gauge rod to indicate the measure when extended beyond the end of the bed. The cutting arrangement has no superior, being operated by a compound lever and provided with a shear cut for brass and a straight cut for leads.

The support to the right prevents any sag in the material between the front gauge and the knives. In cutting very short pieces it may be turned back out of the way, as indicated in cut. The machine rests on three feet, which insures a steady support no matter how uneven the surface on which it is placed. For accurate work this machine is without an equal. Material and workmanship the very best.

Capacity of bed gauge, up to 105 ems by Nonpareils; capacity of front gauge, up to 48 ems by points.

Price \$12 00

AMERICAN LEAD AND RULE CUTTER No. 2.

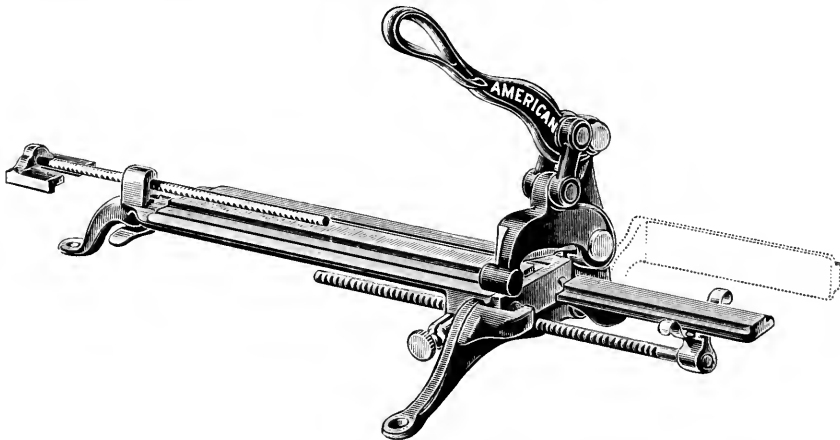

This cutter is the same as the American Lead and Rule Cutter No. 3, with the exception that the front gauge sets to Nonpareils only instead of to points, and is undoubtedly the best machine ever sold at the price.

Price \$10 00

AMERICAN LEAD AND RULE CUTTER No. 1.

This machine is very strong and compact. It is provided with a reversible bed gauge which is held in position as in a vise, the post through which the gauge-rod passes having a narrow slit in the top and a thumb-screw by means of which the rod is clamped quickly and securely. This cutter also has the grooved bed which, with corresponding projections on gauge-head, preclude the possibility of thin material getting under the gauge. The front gauge is held by a thumb-screw, as usual.

Material and construction unsurpassed—in fact, the best \$8.00 cutter made. Capacity of bed gauge, 13½ inches; capacity of front gauge, 6½ inches.

Price \$8 00

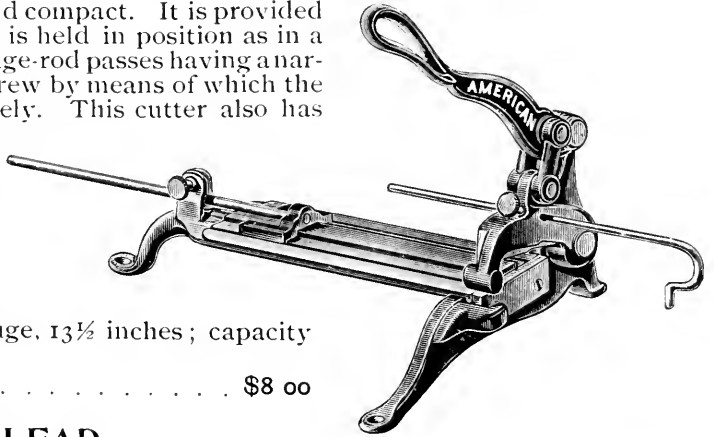

HANDY LEAD CUTTER.

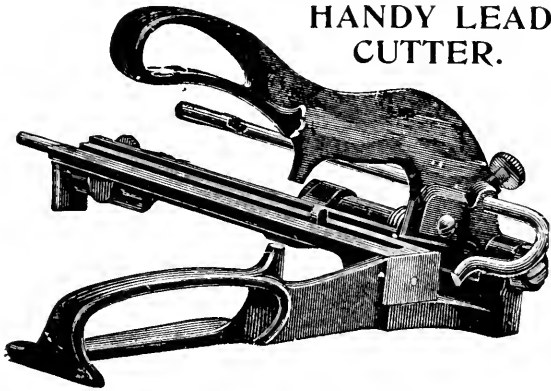

Will cut leads and slugs six points thick, and, although not recommended as a rule cutter, will cut two-point brass rule. Has back and front gauges. Leads can be cut very rapidly and easily on this cutter by holding the lever and the handhold on frame in right hand, as in using hand shears. To get the best results this cutter should be screwed to bench or table.

Price \$4 00

CHANDLER & PRICE LEAD AND RULE CUTTER.

The bed and gauge are graduated to Picas.

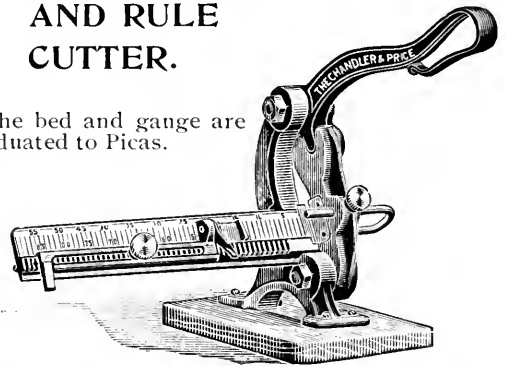

The bed is nearly vertical, and the lead or rule drops against the gauge edge by gravity, assuring a square cut.

Gauges 14 inches \$8 00

UTILITY LEAD CUTTER.

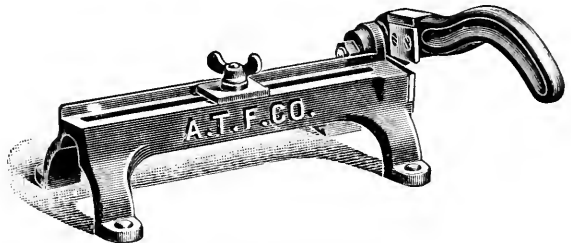

The strongest cheap lead cutter made. A reliable, cheap tool.

Price \$2 00

LEAD AND RULE CUTTERS.

No. 1 \$8 00
Gauges 12 inches.

No. 2 \$9 00
Graduated to Picas; gauges 12 in.

No. 3 (extra heavy) \$12 00
Bed, 13 in.; graduated to Picas; gauges 18 in.

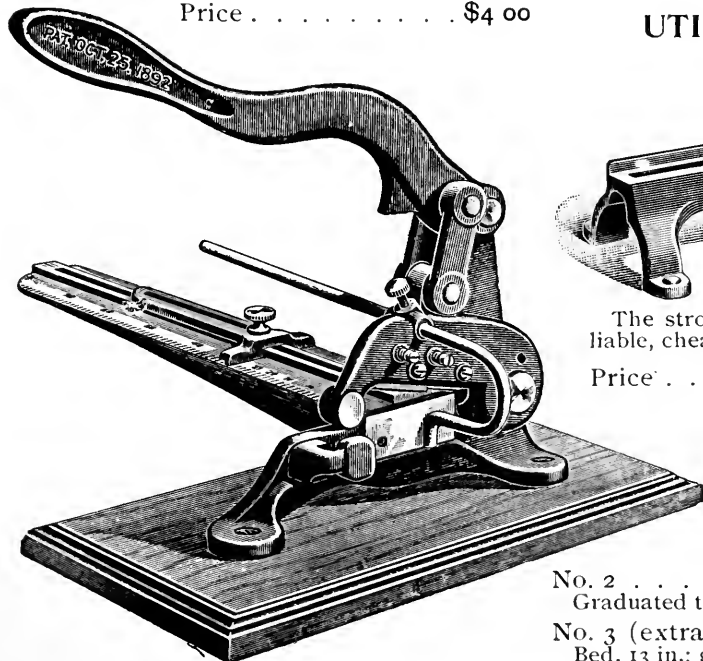

PATENT UPRIGHT MITER MACHINE.

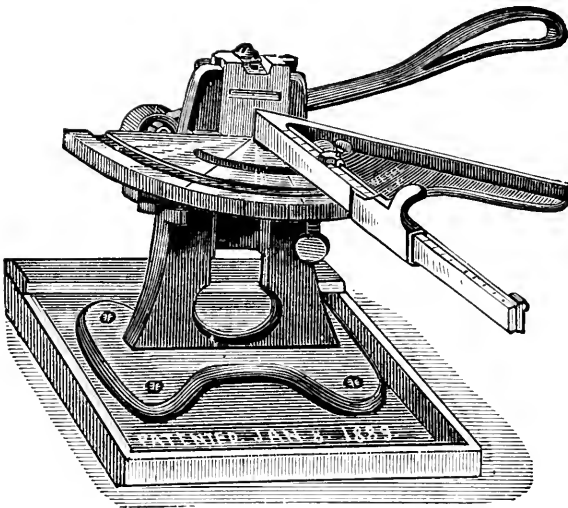

A strong, well-built, accurate machine. The cutting or shaving head has a positive up-and-down motion, and must cut as much at the bottom as at the top, as it cannot slip. The knife is regulated by set-screw. The sliding gauge is the best of its kind, enabling the operator to feed the rule up to the knife, but affords a positive check at the point where the desired length is reached. The bed is graduated, and is made movable, so that the whole cutting-edge of knife can be used. This machine is mounted in a strong, shallow, wooden box, which catches the shavings, and has at the front end an emery board on which the burr of the rules may be rubbed off.

With Sliding Gauge \$13 00
 With Micrometer Point-System
 Gauge 20 00

PRINTERS' CURVING MACHINE.

On this machine the curves are made by pressure between three iron rollers (two below and one on top), and the pressure is regulated by the screw at left hand side, which acts on a lever that raises or depresses the lower rollers. The action is very rapid, and, in the hands of an expert, accurate.

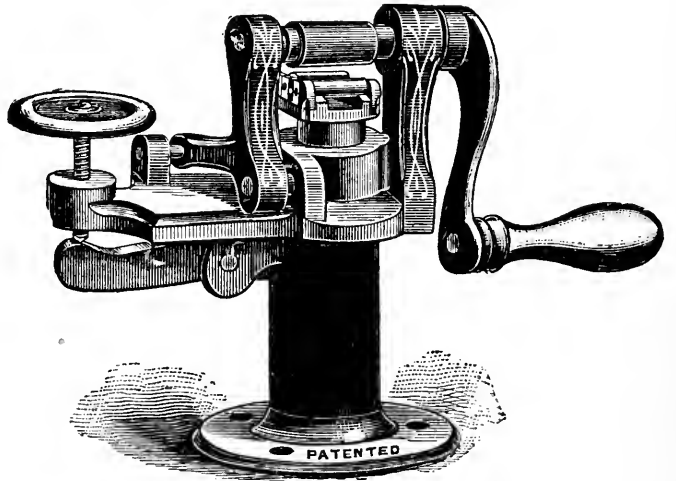

Price \$15 00

ELITE RULE BENDER.

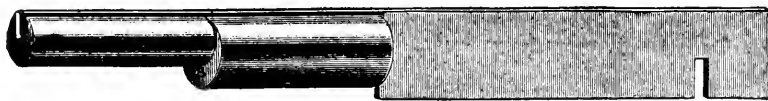

The blade is tool steel and the cylinders of brass. Bends rule from one to six points in thickness. The end of the rule is firmly held in the grooves in cylinder, and can be twisted into any shape.

Price, with instructions for rule bending \$2 00

THE BEST SAW FOR PRINTERS.

The Universal Sawing Machine, described on page 1048, is specially recommended as the best saw made for accurately cutting brass rule to labor-saving measure. The gauge of this machine can be set from one-half to fifty Picas, including all the halves in this measure.

PRINTERS' SUPPLIES.

BODKINS.

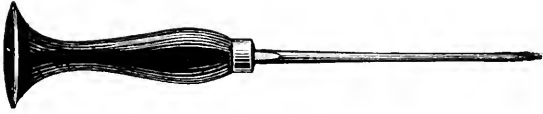

No. 2, wood handle, needle steel,
each \$0 10

TWEEZERS.



This is good and cheap; polished steel; Nonpareil points.

No. 11, nickel-plated, each \$0 25



This is the best Tweezer procurable at the price; file point, steel, 4 inches long.

No. 5, nickel-plated, each \$0 50



These are the best made; tempered steel, nickel-plated, file-cut points and backs. No. 7 is 4 inches long; No. 8, 4 3/4 inches long.

No. 7, nickel-plated, 4 inches long, each \$0 75
No. 8, nickel-plated, 4 3/4 inches long, each 0 85



The only Tweezer that can be carried in the pocket with comfort and safety. It locks and unlocks automatically. Hold it points down and press between fingers gently, and it unlocks; hold it points up and bring points together, and it locks securely.

No. 9. Self-locking, nickel-plated, each \$0 90

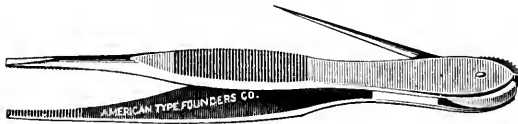

When Tweezer is in use the Bodkin folds into it. When Bodkin is required, pressure on the file-cut arc shown in cut brings it out easily, and when extended it locks securely, and is as firm as an ordinary Bodkin. This is the latest and most satisfactory combination. Patent applied for.

No. 3. Combination Tweezer and Bodkin, nickel-plated, each \$1 00

COMPOSING AND MAKE-UP RULES.

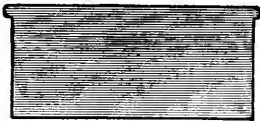

Steel Composing Rules, 15 ems and under, each \$0 25

Add 5 cents to above from 15 to 20 ems, and 10 cents extra from 20 to 25 ems.

Nickel plating, 15 cents extra.

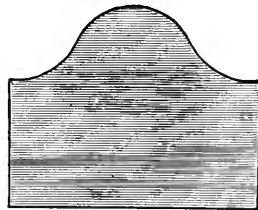

Steel Make-up Rules, 15 ems and under, each \$0 30

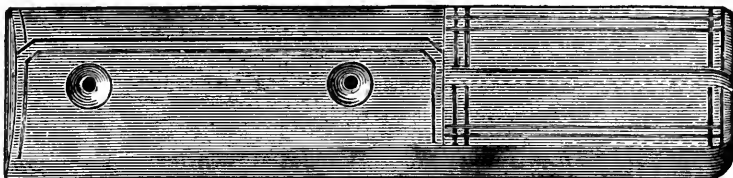

Set of 12 Steel Composing Rules, in leather case \$1 50

Sizes: 12, 13, 13 1/2, 14, 15, 16, 18, 21, 24, 26 1/2, 28, 30 ems.

COMPOSING STICKS.

THE BUCKEYE.

Quick and easy to set; will not slip; lies flat; as secure as the Common Screw Stick, and easier to set than the Yankee Job Stick.

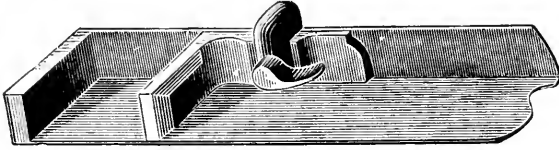

| | |
|---------------------------------|-----------|
| 6 ins. × 2, 2¼ or 2½ ins. deep | .. \$0 90 |
| 8 ins. × 2, 2¼ or 2½ ins. deep | .. 1 00 |
| 10 ins. × 2, 2¼ or 2½ ins. deep | .. 1 20 |
| 12 ins. × 2, 2¼ or 2½ ins. deep | .. 1 40 |
| 14 ins. × 2, 2¼ or 2½ ins. deep | .. 1 60 |
| 16 ins. × 2, 2¼ or 2½ ins. deep | .. 1 80 |
| 20 ins. × 2, 2¼ or 2½ ins. deep | .. 2 20 |
| 24 ins. × 2, 2¼ or 2½ ins. deep | .. 2 60 |

YANKEE JOB.

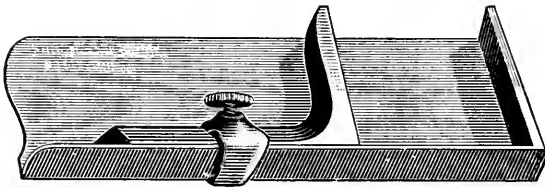

| | |
|---------------------------------|-----------|
| 6 ins. × 2, 2¼ or 2½ ins. deep | .. \$0 75 |
| 8 ins. × 2, 2¼ or 2½ ins. deep | .. 0 80 |
| 10 ins. × 2, 2¼ or 2½ ins. deep | .. 1 00 |
| 12 ins. × 2, 2¼ or 2½ ins. deep | .. 1 15 |
| 14 ins. × 2, 2¼ or 2½ ins. deep | .. 1 30 |
| 16 ins. × 2, 2¼ or 2½ ins. deep | .. 1 45 |
| 18 ins. × 2, 2¼ or 2½ ins. deep | .. 1 60 |
| 20 ins. × 2, 2¼ or 2½ ins. deep | .. 1 75 |

COMMON SCREW.

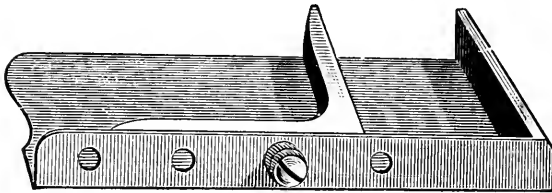

| | |
|---------------------------------|-----------|
| 6 ins. × 2, 2¼ or 2½ ins. deep | .. \$0 75 |
| 8 ins. × 2, 2¼ or 2½ ins. deep | .. 0 80 |
| 10 ins. × 2, 2¼ or 2½ ins. deep | .. 1 00 |

Other sizes to order at same prices as Yankee Job Sticks.

THE GROVER.

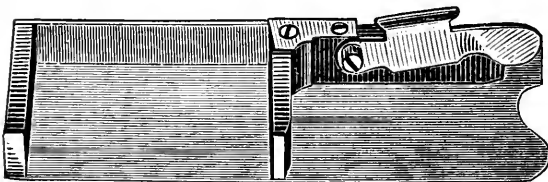

| | |
|----------------------------|-----------|
| 6 × 2¼ inches | .. \$0 90 |
| 8 × 2¼ inches | .. 1 00 |
| 10 × 2¼ inches | .. 1 20 |
| 10½ × 2½ inches (billhead) | .. 1 60 |
| 12 × 2¼ inches | .. 1 40 |
| 16 × 2¼ inches | .. 1 80 |

Extra clasps, 10 cents; extra knees, 40 cents each.

“C” SLOT STICK.

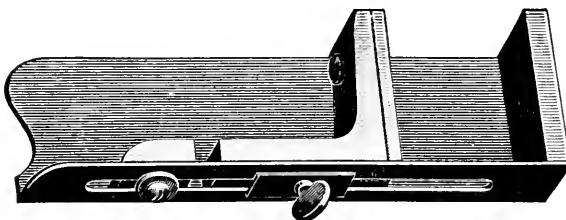

Has two entirely novel features: (1) The inside of face of the knee is adjustable, so that it can be squared up in case the knee wears; (2) The knee is in two sections, so that the Stick can be set to shorter measure without changing the full measure adjustment. See cut, which shows part of the knee at the left set for full measure, while the main part is set to a lesser measure.

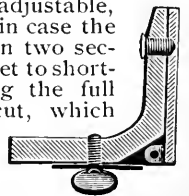

| | | | |
|-----------------------|-----------|------------------------|-----------|
| 6 ins. × 2¼ ins. deep | .. \$1 15 | 10 ins. × 2¼ ins. deep | .. \$1 45 |
| 8 ins. × 2¼ ins. deep | .. 1 25 | 12 ins. × 2¼ ins. deep | .. 1 65 |

AMERICAN JOB STICK.

This composing stick is constructed upon entirely new lines and is destined to become extremely popular. It is made with a series of notches in the back of the stick with corresponding steel teeth in the knee to engage in them, the knee being clamped to the back of the stick, as indicated in engraving. The knee is made with a diagonal brace which effectually prevents springing. This stick can be set to Nonpareils or Picas quicker and more accurately than any other, and it is impossible for the knee to slip or to spring. Just the thing for accurate tabular work. Has a hole near the end to hang it up by.

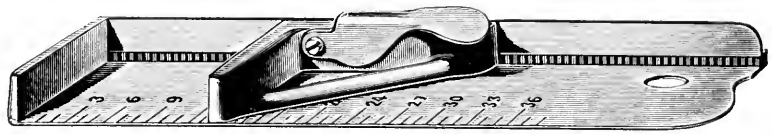

| | 2 Inches Deep. | 2¼ Inches Deep. | 2½ Inches Deep. |
|-------------------|----------------|-----------------|-----------------|
| 6-inch | \$1 75 | \$1 85 | \$1 95 |
| 8-inch | 2 00 | 2 10 | 2 20 |
| 10-inch | 2 25 | 2 35 | 2 45 |
| 12-inch | 2 50 | 2 60 | 2 70 |
| 15-inch | 3 00 | | |

Nickel plating, extra, 30 cents.

PERFECT NEWS STICKS.

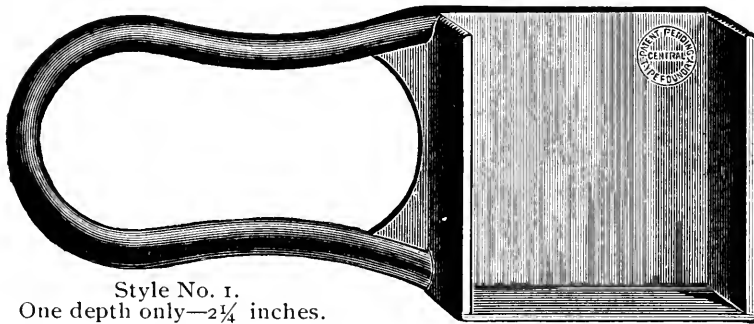

Style No. 1.
One depth only—2¼ inches.

These Sticks are made for setting one measure only, either 13 or 13½ ems Pica, and prevent all the annoyances due to variations in Sticks set inaccurately by careless compositors. It is undoubtedly the best Stick made for news measures.

Style No. 1 is made of best malleable iron; the handle and under side are japanned, so that the Stick cannot rust; the pan itself is milled out,

the sides being absolutely square and rigid, and altogether the Stick is as perfect as could be desired. Made one depth—2¼ inches—only, and for 13 or 13½ ems Pica measure.

Style No. 2 is made of the best of steel, and the set bar or knee is riveted firmly to bottom and back of Stick. It is accurate in every respect.

These Sticks are made for 13 or 13½ ems Pica measure, and are 2½ inches deep.

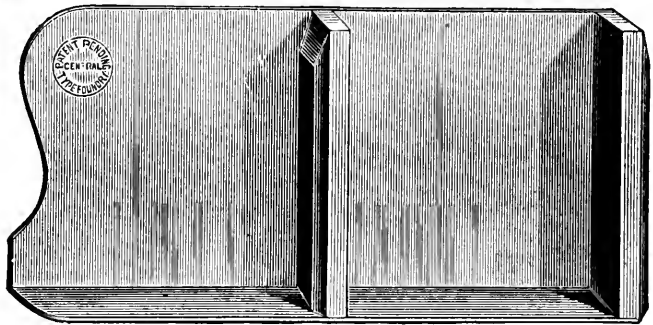

Style No. 2.

| | |
|---|--------|
| No. 1. Malleable Iron, milled, for 13 or 13½ ems Pica measure | \$0 75 |
| No. 2. Steel-riveted, for 13 or 13½ ems Pica measure | 0 80 |

WOODEN POSTER STICK.



With brass-lined ends, iron knee and screw clamp.

| | |
|---------------------|--------|
| 16 inches | \$1 00 |
| 20 inches | 1 10 |
| 24 inches | 1 20 |
| 30 inches | 1 35 |
| 36 inches | 1 50 |
| 42 inches | 1 80 |

PRINTERS' EYE SHADE.

| | |
|---------------------|--------|
| Per dozen | \$1 50 |
| Each | 0 15 |

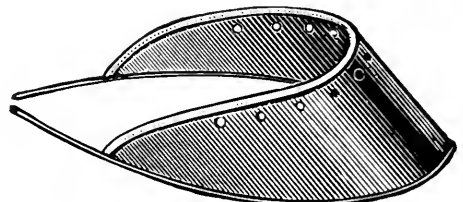

COMPOSING STICK RACK.

This Rack holds twelve Sticks, and can be attached to the wall or any other convenient place. The Sticks are held securely, and are preserved from the damage liable to them when "kicking about."

Each \$1 50

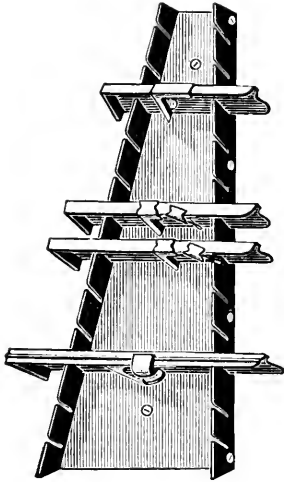

KELSEY COPY HOLDER.

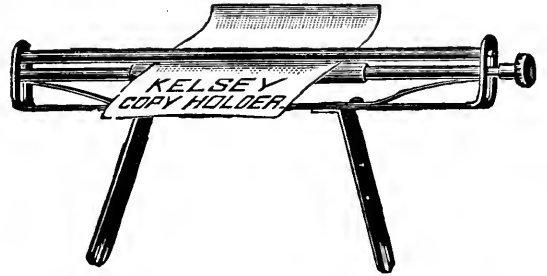

Price, each \$0 75

BRASS LABEL HOLDER.

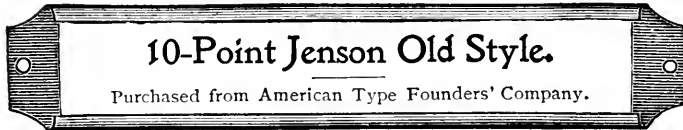

The utility of these Label Holders is apparent at a glance, especially when extra men are put on, as it enables them to locate the type quickly.

Size, 1x5½ inches, per hundred, with cards and tacks complete \$2 75

Size, 1x5½ inches, per dozen (least quantity sold), complete 0 50

Other sizes furnished to order.

TYPE MEASURES.

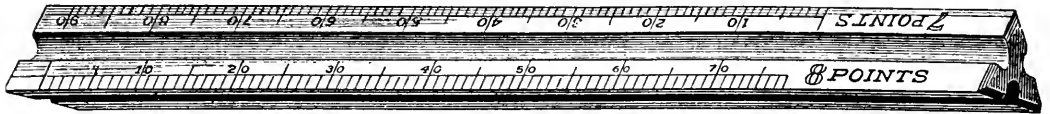

Boxwood Triangular Type Measure.

Boxwood, triangular shape, the best, 9 inches \$1 50

Boxwood, triangular shape, the best, 18 inches 3 00

This Type Measure is superior to any, and is guaranteed to be accurate. The sides of the triangle are grooved, so that it is easily handled. It will measure any size from 5½ Point to 18 Point, and all multiples of 6 Point.

Square Brass-Edged Wooden Type Scale, No. 120 \$0 30

Measures 5½, 6, 7, 8, 9, 10, 11 and 12 Points, and has 12-inch scale.

Patent 12-inch Cardboard Type Scale \$0 25

Measures 4½, 5, 5½, 6, 7, 8, 9, 10, 11 and 12 Points, and has 12-inch scale.

Lincoln Type Measure, steel tape, 24 inches long, in German silver case, each \$2 00

Measures 376 lines of Agate (14 lines to the inch); 288 of 6 Point; 246 of 7 Point; 216 of 8 Point; 192 of 9 Point; 172 of 10 Point; 157 of 11 Point; 144 of 12 Point; and has a 24-inch scale, all plainly marked.

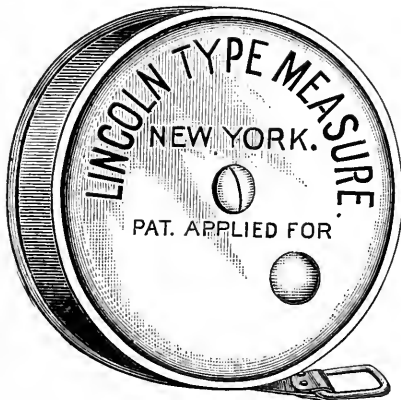

Exact size.

BRACKETS.

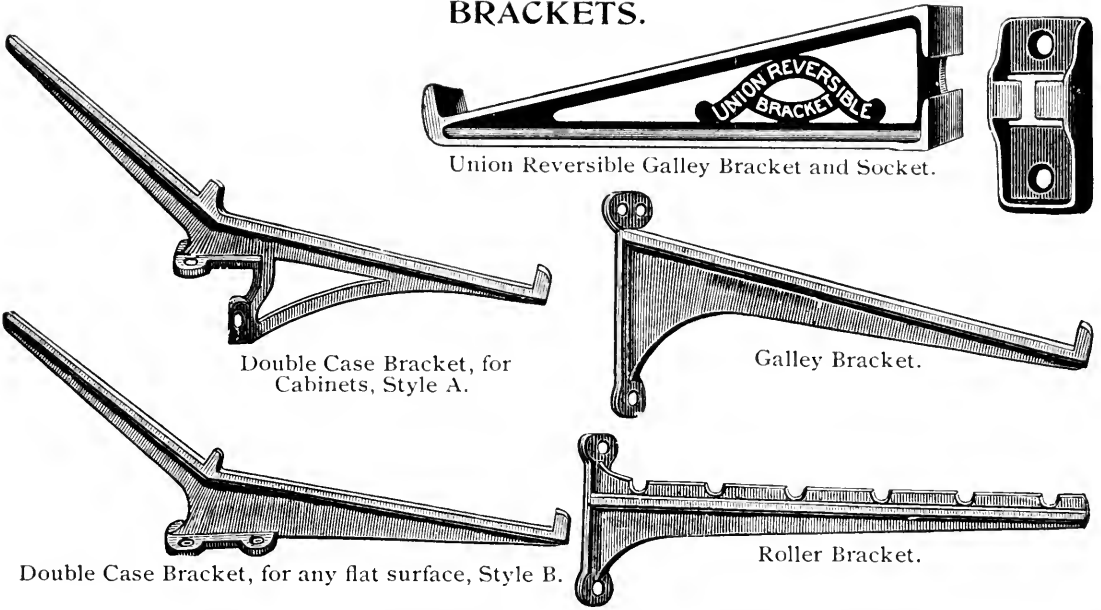

| | |
|---|--------|
| Double Case Brackets, style A, fit on end of Flat Top Cabinet, per pair | \$1 50 |
| Double Case Brackets, style B, fit on any flat surface, per pair | 1 25 |
| Single Case Brackets, per pair | 0 75 |
| Galley Brackets, per pair | 0 40 |
| Roller Brackets, to hold six platen press rollers, per pair | 0 50 |
| Union Reversible Galley Brackets, with Sockets, per pair | 0 60 |
| Union Reversible Galley Brackets, with Sockets, per dozen pairs | 6 00 |

CHALLENGE LAMP HOLDER.

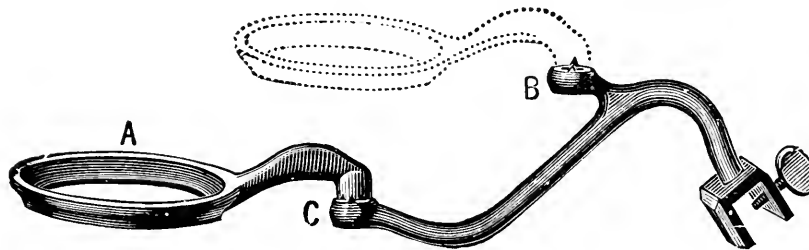

A most convenient and safe attachment for holding a lamp over the compositor's case. It will be readily understood by reference to the cut that the fount holder A can be instantly raised from C to B, as shown by the dotted lines, to adapt the position of the light to suit the compositor. Small thumb screws at

the top of B and C, with suitable recesses in A, retain the light perfectly stationary in any position.
 Each \$0 75

TYPE-HIGH GAUGE.

Much time may be saved in the press room if the maker-up will test all electrotypes, and have those that are high or low brought to the proper height by an electrotyper, or do it himself, before the form goes to press. The wise employer should insist on the use of this gauge.

Price, each. \$2 50

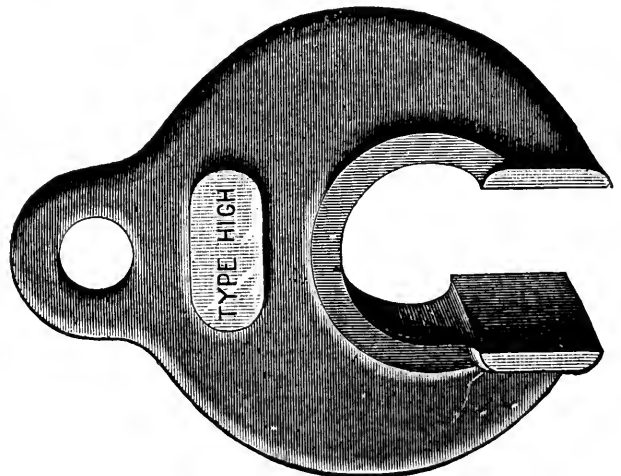

See *Type-High Machines* on pages 1048 and 1049.

BELLOWS.

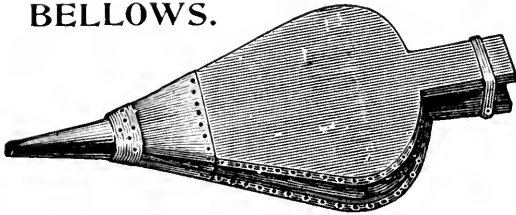

These bellows are correct in shape, and strongly made of the best materials.

- Small size \$1 00
- Large size 1 25

COPPER THIN SPACES.

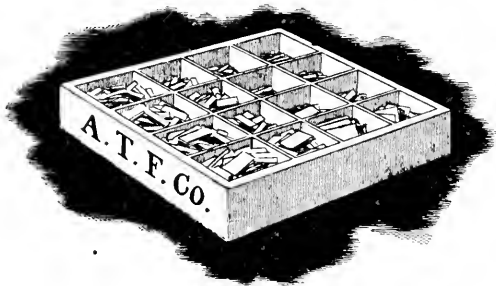

No office should be without them. They make the justification of a line of job type, any size, a pleasure. Supplied in wooden cases containing 16 compartments (see illustration), from 6 to 72 point. Also furnished in pasteboard boxes containing 5 sizes, from 12 to 48 point.

- Wooden case, with 16 ounces of either 1/2- or 1-point spaces net \$1 75
- Pasteboard box, with 10 ounces assorted 1/2- and 1-point spaces . net 1 00
- 2-ounce packages, any one size . net 0 25

SAW.

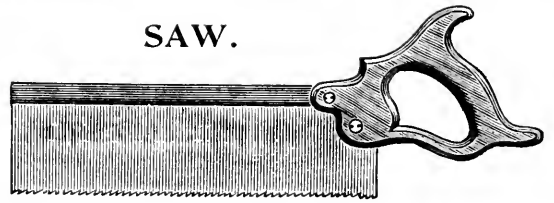

Back saw, for cutting wood or soft metal \$1 25

MITER BOXES.

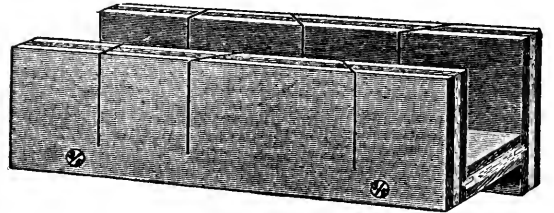

Our improved wood miter boxes are made of 3-ply glued stock, and will outlast the usual kind three to one. Will not break if thrown on the floor, and will resist all sorts of careless usage.

- Wood, 13 1/2 ems wide, each \$0 50
- Wood, 3 inches wide, each 0 60
- IRON, each 2 50

PRINTER'S DIVIDERS.

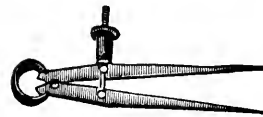

Always useful in laying out margins and distances, imposing plate forms, etc. A great time saver.

Price, each \$0 85

KEYSTONE HACK SAWS.

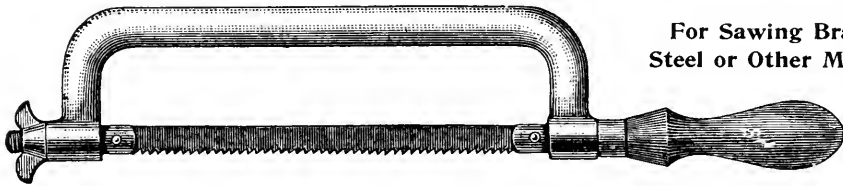

For Sawing Brass, Steel or Other Metals.

The saw blade is secured to the iron frame by two pins, and may be detached easily. When worn it is cheaper to put in a new blade than to refile. One dozen extra blades are furnished with each frame. This is a useful tool in any printing office for cutting thick brass rules, iron side sticks, etc.

- Eight-inch Keystone hack saw, polished frame, with one dozen saw blades \$1 50
- Extra blades, eight-inch, per dozen 1 00

SHOOTING STICKS.

- No. 3, wrought steel, nickel-plated, large, each \$0 75
- No. 2, wrought steel, nickel-plated, small, each 0 60
- Malleable iron, japanned, each 0 30
- Hickory shooting sticks, per dozen, 85 cents . . each, 0 08

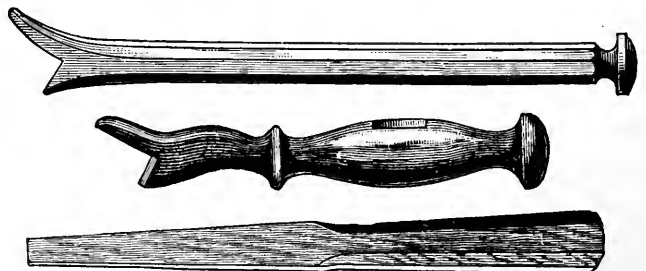

INK KNIVES.

- 6-inch blade, Style B . . . \$0 60
- 8-inch blade, Style B . . . 1 00
- 10-inch blade, Style B . . . 1 60

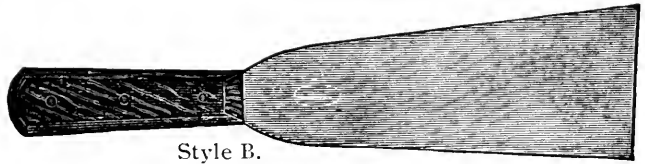

Style B.

CHALLENGE INK SPADE.

It is all steel, full nickel plate, and will not discolor the daintiest tint.

- Steel handle, spring steel blade . . \$0 50
- By mail, 12 cents extra.

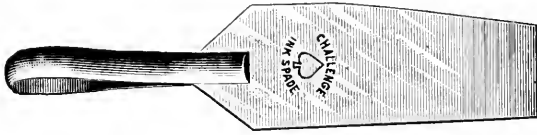

PAPER FOLDERS.

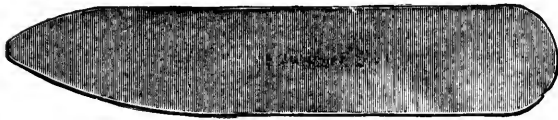

Also used for feeding cylinder presses.

- Steel, nickel-plated, 6 x 1 1/4 inches, each . . . \$0 50
- Bone, each, 25 cents; per dozen . . 2 50

ST. JOHN PAPER KNIFE.

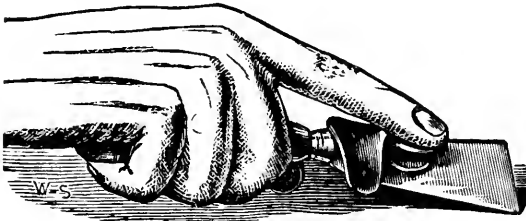

Made of fine steel and suitably pointed for cutting paper. Upon the back of the blade is fixed a broad guard, shaped to fit the finger, by which the operator is enabled to cut much faster and more easily than with a common knife.

- Price . . . \$0 50

PALLET INK KNIVES.

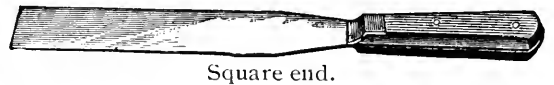

Square end.

- 6-inch blade . . . \$0 50
- 8-inch blade . . . 0 70
- 10-inch blade . . . 1 00

INK SLICE.

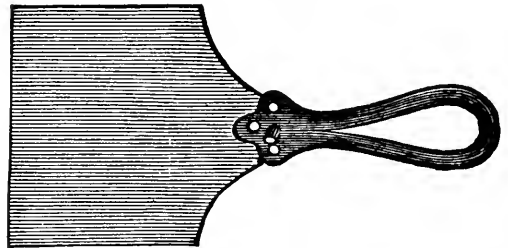

- Brass handle, steel blade . . . \$0 75

OVERLAY KNIFE.

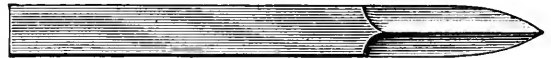

- In leather case, 6 x 1/16 inch, nicked . \$0 60

ENGRAVERS' TOOLS.

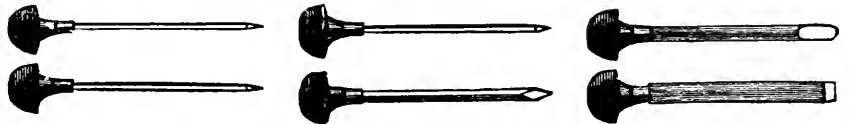

- Six tools, sharpened for use, with handles, in box . . . \$2 50

ENGRAVERS' WOOD.

Prepared to order, in the best manner. Prices are net. The minimum charge for Boxwood or Maple is twenty-five cents.

- Boxwood, per square inch . . . 2, 3, 4 and 5 cents.
- Maple, per square inch . . . 1 1/2 cents.
- Side-wood Poster Tint Blocks, 27 1/2 x 39 1/4 inches . . . \$1 25 each.
- Side-wood Poster Tint Blocks, per square foot . . . 0 25

MAGNIFYING AND REDUCING GLASSES.

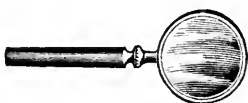

Every careful printer needs these glasses. They are three inches in diameter, in strong metal frames with handle.

- Magnifying Glass, each . . . \$1 65
- Reducing Glass, each . . . 1 50

- STARS FOR FLY STICKS, per hundred . . . \$2 50

GAUGE PINS AND GUIDES.

See explanation of Nos. below.

| | |
|--|--------|
| Original Steel Gauge Pins, Nos. 1, 2, 3, 4, per dozen | \$0 60 |
| Golden Steel Gauge Pins, Nos. 1, 2, 3, 4, 5, 6, per dozen | 0 40 |
| Spring Tongue Gauge Pins, one size only, per dozen | 1 20 |
| per set of three | 0 40 |
| Flexible Side Gauge Pins, per dozen | 0 60 |
| Perfect Register Gauge Pins, per set of three | 1 25 |
| Screw Adjusting Gauge Pins, one size only, per set of three | 1 00 |
| Extension Feed Guides, per pair | 1 00 |
| Cylinder Side Guides, each | 0 50 |
| Extra Tongues for Spring Tongue, "Perfect," or Screw Adjusting Pins, per dozen | 0 25 |
| Gauge Pin Drawers (see illustration at bottom of page), each | 0 25 |

EXPLANATION OF NUMBERS.

No. 1 gauges are 12 points high, with lip $\frac{1}{16}$ -inch long; No. 2, 15 points high, $\frac{1}{16}$ -inch lip; No. 3, 18 points high, $\frac{1}{16}$ -inch lip; No. 4, 12 points high, short lip; No. 5, 15 points high, $\frac{1}{8}$ -inch lip; No. 6, 12 points high, $\frac{1}{4}$ -inch lip. All gauges with tongues are 12 points high.

GOLDEN STEEL GAUGE PIN.



ORIGINAL STEEL GAUGE PIN.



SPRING TONGUE GAUGE PIN.

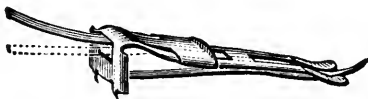

This is the most satisfactory gauge pin made. It meets almost every requirement of the pressman.

FLEXIBLE SIDE GAUGE PIN.



May be placed directly under the gripper where it comes down upon the tympan. The sheets are fed to the curved spring arm. The pin is made of fine thin steel, and, having teeth, is adjustable and prevents the sheets from slipping under.

EXTENSION FEED GUIDES.

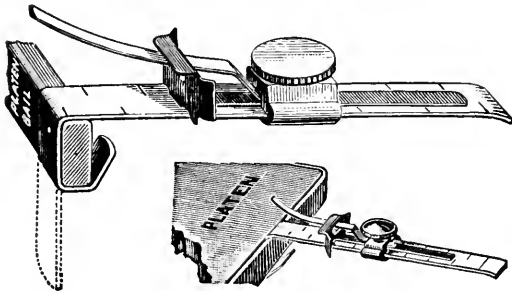

The cut shows the method of securing the guides between platen and platen bail, so that sheets may be fed below the lower edge of the platen.

PERFECT REGISTER GAUGE PIN.

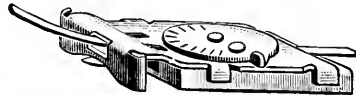

Pastes on like a quad, has a thin steel clip which strikes into tympan and prevents sheets from slipping under gauges, and is adjustable after pasting on.

SCREW ADJUSTING GAUGE PIN.

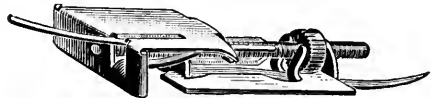

The prong should be inserted a quarter inch below the feeding line and forced snugly home. The base may be secured to the tympan with paste or glue if desired. The adjustment is got by means of the screw and nut with absolute precision and without weakening the hold of the pin to tympan.

CYLINDER SIDE GUIDE.

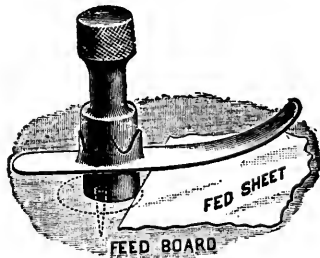

Secured to feed-board by the sharp point shown in outline in cut, which is placed at the side of pillar, so that hair adjustments may be got by simply turning the pillar to the desired position. The bendable brass tongue is adjustable in every direction.

GAUGE PIN DRAWER.

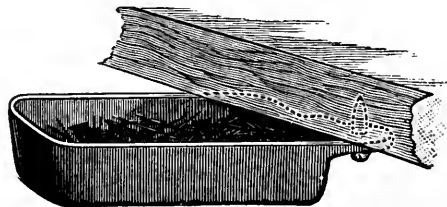

Screws on under the feed-board.

PRESS POINTS.

For inserting in wood furniture when sheets are printed for folding machine. Points are screwed into wood with wrench as far as the cross pin will allow, when they will be found to be correct height.

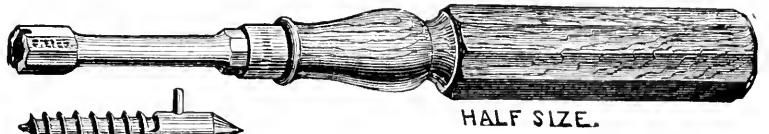

Points, per dozen \$o 75
Wrench o 75

DILLINGHAM PRESS PUNCH.

Patented March 2, 1897.

Is secured to the tympan of platen presses in same manner as a feed guide, and punches a clean hole in card or paper simultaneously with the printing on jobs which have a margin of one inch or more. The method of working this punch is clearly shown in accompanying half-tone. The slightly curved spring is placed under the upper tympan sheet, and the sheet to be punched is fed over this curved

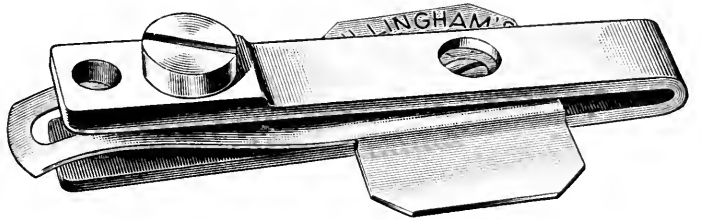

spring and under the punch with no more trouble than in feeding and under the punch to gauge pins. The punch is secured to the tympan by paste or glue or (better still) by a mixture of paste and glue. Two or more punches can be used on one sheet. Punching and printing can be done simultaneously on a variety of work, such as window cards, programmes, orders of dance, souvenirs, etc.

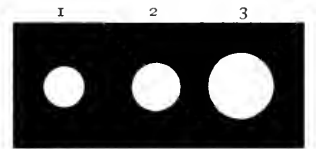

Made with three size holes, Nos. 1, 2 and 3, as per diagram. No. 3 will be sent unless otherwise ordered.

Each, with directions, net \$1 25

ELM CITY PRESS PUNCH.

One or more may be locked in a type form and will cut a clean, round hole $\frac{1}{8}$, $\frac{3}{16}$ or $\frac{1}{4}$ inch in paper or card stock at the same time the job is printed. This punch will not clog, as each piece cut is automatically ejected by the plunger as soon as the impression is released and falls on the floor. The ejector also protects the rollers from any danger of injury from the cutter. The punches are made on 30 and 36 point bodies. All parts being interchangeable, new cutters can be readily fitted in case of accident. The spring for controlling the ejector can also be made stronger by turning screw at bottom. The cutters are made two points lower than type to allow for pasting a small square of cutting fibre, which are furnished with punches, on the tympan.

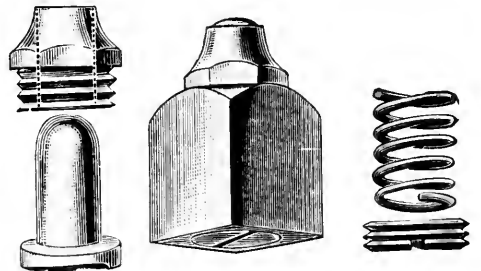

Per set for cutting $\frac{1}{8}$, $\frac{3}{16}$ and $\frac{1}{4}$ in. holes \$1 50
One punch, any size o 75

Extra cutters, made of finest tool steel, \$o 15
Cutting fibres, per doz o 10

PRESS PUNCH.

This punch is about one thirty-second inch lower than type, and can be locked up in a type form, thus enabling printers to punch holes in stock at the same time it is printed, without extra expense. A piece of 2-point brass rule should be cemented to the tympan sheet for the punch to strike on, and an opening left in the form opposite opening in base of punch to prevent it from becoming clogged. Made of best tool steel, tempered.

For $\frac{1}{8}$, $\frac{3}{16}$, or $\frac{1}{4}$ inch hole, each \$1 00

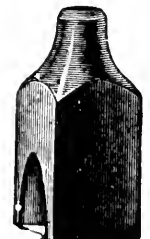

HEMPEL IMPROVED QUOIN.

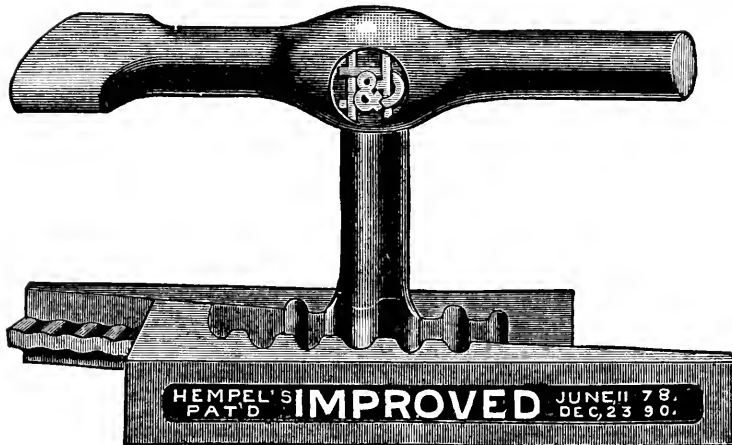

The Hempel Quoins are the standard, tested by time and approved by those who use them. This is the latest improved quoin.

| | |
|---|--------|
| No. 1 small, per dozen pairs | \$2 50 |
| No. 2, large, per dozen pairs | 3 00 |
| Keys, each | 0 50 |

IMPROVED BROWER QUOIN.

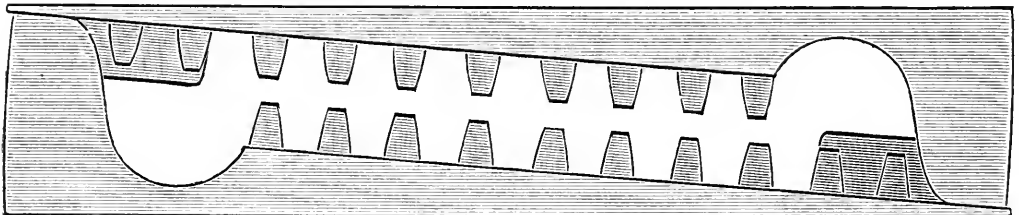

No. 2 Brower Quoin, actual size.

Has central racks, and consequently will not throw type off its feet. Works smoothly. The key, of steel, with cut teeth, has a firmer and deeper hold than in the old style quoin.



No. O. "Little Samson," actual size.

The No. O, as illustrated, is the smallest wedge quoin ever made, and will prove very valuable for job printers and on occasions when lock-up must be made in small spaces.

| | |
|--|--------|
| No. O, smallest wedge quoin made, "Little Samson," per dozen | \$2 00 |
| No. 1, medium size, per dozen | 2 50 |
| No. 2, large size, per dozen | 3 00 |
| Steel keys, all sizes, each | 0 50 |

| | Per Dozen. | Key. |
|---|------------|------|
| PERRY QUOIN | 2 50 | 0 50 |
| CHALLENGE HEMPEL QUOIN, No. 1 | 2 50 | 0 50 |
| CHALLENGE HEMPEL QUOIN, No. 2 | 3 00 | 0 50 |

UNION LOCKABLE QUOIN.

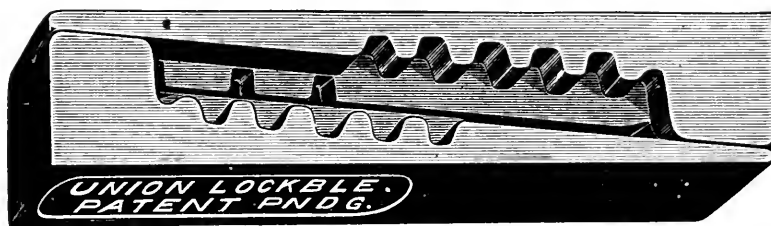

An exact duplicate of the original Hempel Quoin, with three notches cut in the central rib for the purpose of using the quoin in connection with the Patent Brower Lock, listed below.

No. 1, small, per dozen \$2 50 | No. 2, large, per dozen \$3 00
 Keys, each \$0 50

BROWER QUOIN LOCK.

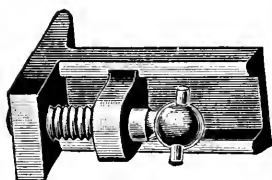

Fig. 2. The Lock.

The sidewise projection shown in Fig. 2 engages in notches cut in central rib of Union Lockable Quoin, or in the rack teeth of the Brower Quoin (see opposite page). The screw is then set up against the other half of the quoin, effectually preventing it from slipping. Quoins of the wedge principle are all liable on long runs to be loosened by the vibrations of the press. These locks make the lock-up doubly sure. They should be applied by the pressman after he has completed the make-ready and before the run is commenced.

No. 0, to fit No. 0 Brower Quoin, per dozen \$2 50
 No. 1, to fit No. 1 Brower Quoin, per dozen 2 75
 No. 2, to fit No. 2 Brower Quoin, per dozen 3 00
 No. 3, to fit No. 1 Union Lockable Quoin, per dozen 2 75
 No. 4, to fit No. 2 Union Lockable Quoin, per dozen 3 00
 Screw-driver, to fasten Quoin Lock, each 50

MIDGET SAFETY QUOIN.

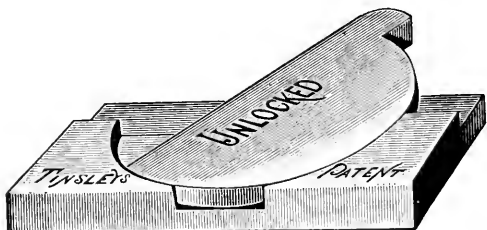

Fig. 3. Shows Midget Quoin unlocked.

It is locked by a tap of a mallet, and occupies no more space in length when locked than when unlocked.

Can be used in a space 18 points wide by 120 points long, either outside or inside a form. It is absolutely safe, as when locked it rests against its corresponding flat surfaces, and the harder the surface it bears against the better.

This invaluable quoin may be used to lock up matter inside a brass circle, or oval, or within a solid border, or in places where no other quoin of wood or metal can be used.

Fig. 1 illustrates how this quoin is used in a mortised cut.

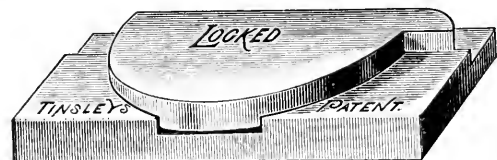

Fig. 2. This cut shows extreme expansion of six points when locked.



Fig. 1. Illustrates the method of unlocking.

Price, per dozen, with key, net \$2 00

Price List of Quoins continued on following page.

THE MORTON LOCK-UP.

Rigid. Direct Spread. Quick. Secure.

An iron side-stick with broad bearings, true and square, attached to the best machine-finished steel quoins. The quickest, safest and most complete lock-up—all in one piece.

Place directly against type, putting furniture (if required) between chase and quoin. Give key a half-turn, and—that is all. No skew or spring; no waste of time or patience; and *no quoin can drop out* through carelessness, if any one has sufficient bearing.

The Morton Lock-Ups vary from exact inch measurement to agree (practically) with point lengths.

PRICES.

| | Each. |
|------------------------|--------|
| 3½-in., 1 quoin . . . | \$0 40 |
| 4-inch, 1 quoin . . . | 0 40 |
| 5-inch, 1 quoin . . . | 0 40 |
| 6-inch, 1 quoin . . . | 0 45 |
| 6-inch, 2 quoin . . . | 0 70 |
| 7-inch, 2 quoin . . . | 0 70 |
| 8-inch, 2 quoin . . . | 0 75 |
| 9-inch, 2 quoin . . . | 0 75 |
| 10-inch, 2 quoin . . . | 0 80 |
| 12-inch, 3 quoin . . . | 1 10 |
| 13-inch, 3 quoin . . . | 1 15 |
| 15-inch, 3 quoin . . . | 1 20 |
| 18-inch, 3 quoin . . . | 1 30 |

KEYS.

| | Each. |
|--------------------|--------|
| Plain | \$0 50 |
| Polished | 0 75 |

Newspaper side-sticks and special lengths to order.



THE WICKERSHAM QUOIN.

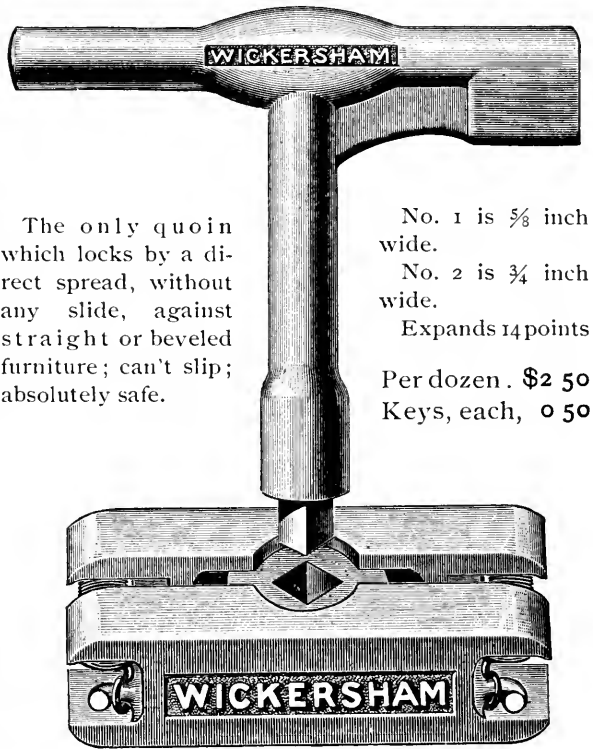

The only quoin which locks by a direct spread, without any slide, against straight or beveled furniture; can't slip; absolutely safe.

No. 1 is 5/8 inch wide.

No. 2 is 3/4 inch wide.

Expands 14 points

Per dozen . \$2 50
Keys, each, 0 50

ACME METAL EXTENSION FURNITURE.

Designed to save time in lock-up forms for job presses. It is quickly handled, and is adjustable according to Picas, extending from two and one-quarter to four inches. When locked up it is perfectly secure.

Price, per set of four . . . \$1 50
Per dozen (three sets) . . . 4 00

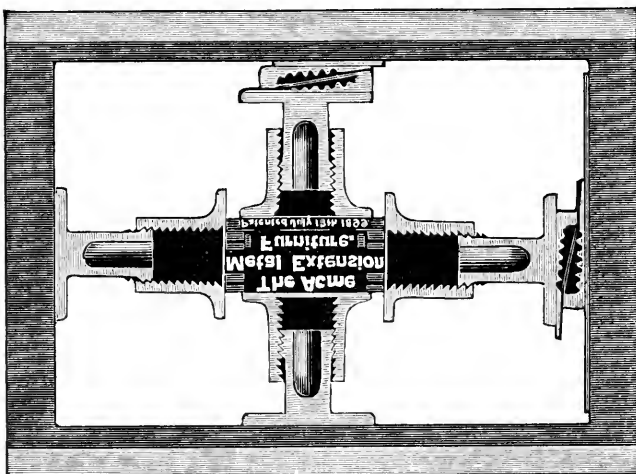

NEVER-SLIP QUOIN.

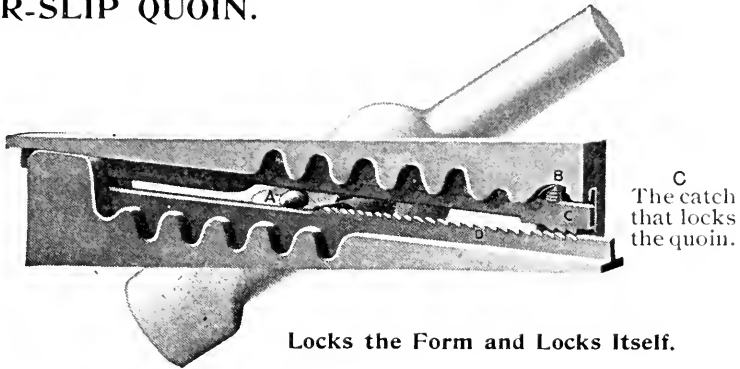

This quoin possesses all the advantages of any other quoin made. It is impossible for this quoin to slip after the form is locked up with it. This alone makes it of great value on fine work where exact register is required.

The Never-Slip Quoin is adapted to any ordinary work. It saves time, saves the imposing stones and the bed of the press. There is no possible chance of it becoming unlocked on the press. The simplicity of this quoin is its strongest feature. It is handled with a key like the ordinary quoin.

| | |
|----------------------------|--------|
| Price, per dozen | \$3 25 |
| Keys, each | 75 |

PRINTERS' TRUCKS.

Lay Printed Sheets on Trucks and not on the Floor, and thus Save Cost and Loss in Handling.

With platform 34 inches wide by 50 inches long, 11¾ inches high \$16 00

Special prices in quantities. Other sizes at proportionate rates.

Made of hard wood 1¾ inches thick, bolted, varnished. Center wheels, 9¾ inches diameter, 3 inches face. Caster wheels, 4¾ inches diameter, 1¾ inches face. Steel axle, 1¾ inches square, with steel braces 1¼ × ¼ inches. The T-shaped handle is of ¾-inch round steel, and is quickly attached to or detached from two eyelets fixed at each end. Weight, 182 pounds; handle weighs 11½ pounds.

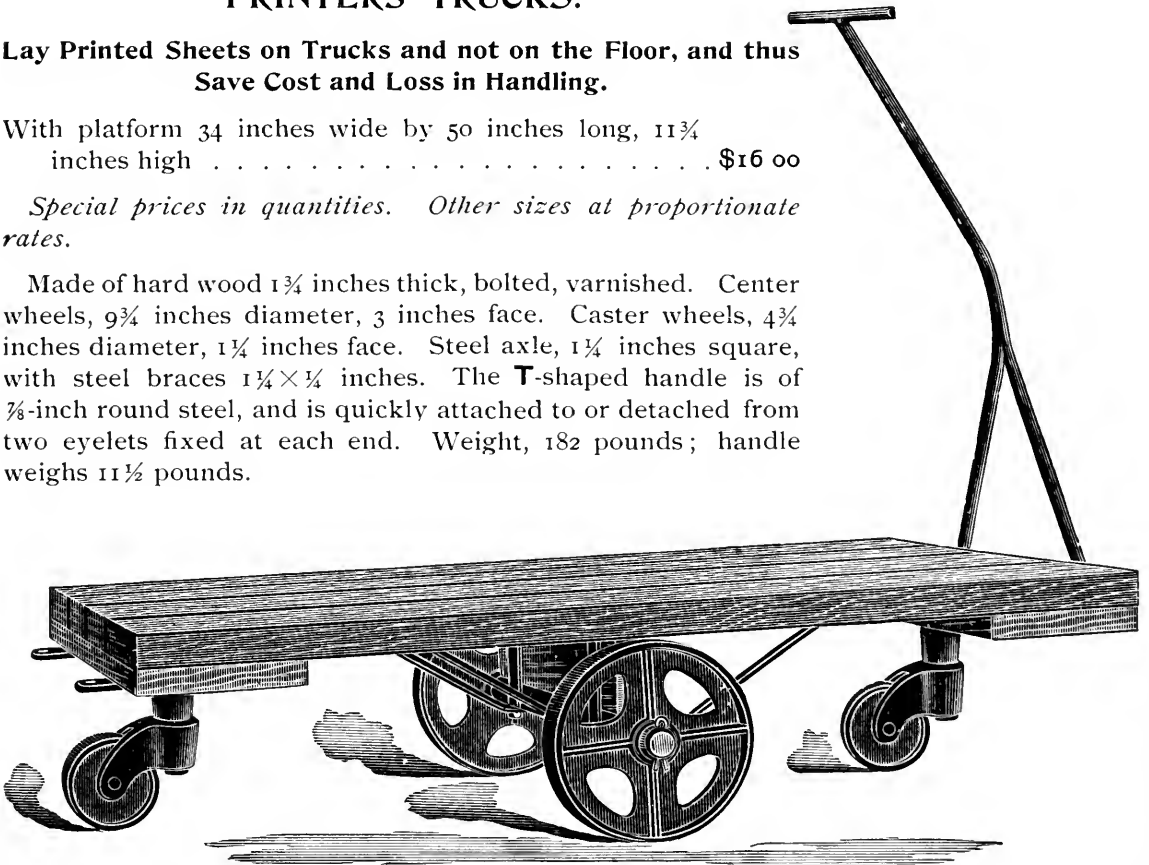

MILLER PERFECT GRIPPER PERFORATOR.

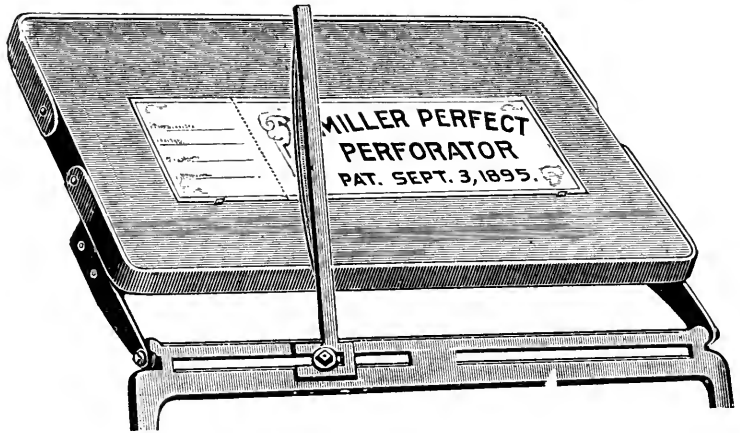
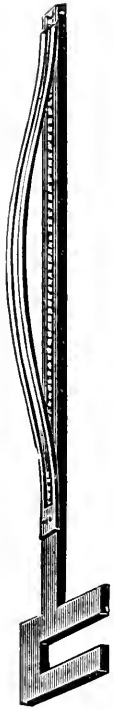

Made of steel, to attach to any platen press. Perforates neatly and cleanly while printing. Does not interfere with impression. There is a half elliptic spring which pushes the perforated sheet off the perforating knife.

- For Eighth-Medium Press, net \$5 00
- For Quarter-Medium Press, net 6 00
- For Half-Medium Press, net 7 00

When ordering it is necessary to state name and size of press.

PERFORATING AND SCORING MACHINE.

This Perforator and Scorer consists of a depressible, or disappearing, interchangeable steel blade (either with perforating or scoring surface), acting in connection with a base plate and lever, all secured within a steel casing and operated by a rubber pressure quad glued to the tympan, which presses against the lever, bringing blade into position just before taking impression.

It locks into the form and saves time, rollers and money by perforating (or scoring) and printing at one impression.

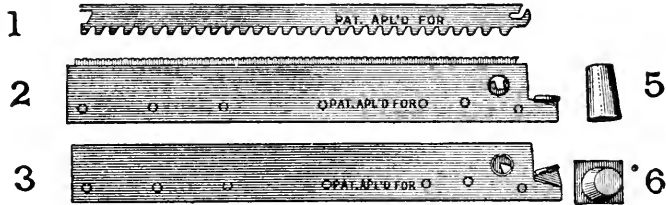

- 1—Creasing Blade.
- 2—Perforating Blade in position to take impression.
- 3—Perforator with Blade depressed.
- 5—Pressure Quad.
- 6—Pressure Quad glued on cardboard.

Made in the following sizes :

| Sizes. | Total length. | Perforates or Scores. | Price. |
|-----------------|---------------------|------------------------|--------|
| No. 1 | 5 inches | 4 1/8 inches | \$3 00 |
| No. 2 | 7 inches | 6 1/8 inches | 4 00 |
| No. 3 | 10 inches | 9 inches | 5 00 |
| No. 4 | 12 inches | 11 inches | 6 00 |



UNION STORAGE CAN.

For Holding Benzine or Oils.

It is strongly made of galvanized iron and is self-closing. There can be no evaporation, and no fluid can be spilled until the nozzle is opened by means of the spring. A very necessary article in all printing offices which are permitted to have one or more gallons of benzine on the premises. Quite a saving in the cost of benzine and oils will be realized by purchasing in the quantities held by these storage cans, besides avoiding the inconvenience of sending out at frequent intervals to get the ordinary benzine can filled up.

| | |
|------------------------|--------|
| 1-gallon can | \$2 00 |
| 3-gallon can | 2 50 |
| 5-gallon can | 3 00 |

UNION SAFE BENZINE CAN.

This is patterned after the original benzine can, with the addition of a circular plate around the head, near the vent, by mean of which the valve is opened without wetting the fingers. When pressure is removed it closes automatically. The head is attached to the can with a chain, so that it cannot be lost

when unscrewed for the purpose of filling with benzine.

Made of tin. Enamelled red.

Holds one quart, each \$0 75



SUCCESS SAFETY BENZINE CAN.

Made of Brass.

By the use of this safety can leakage of benzine or its vapor is prevented, as the stopper is automatically self-locking—always tightly closed when the can is not in use. The flow of benzine, naphtha or any other fluid is regulated by the pressure of the second and third fingers upon a circular plate on the nozzle; and the adjustment is so perfect that one can pour a single drop, or a full stream, at will. It is also neat and cleanly, for the hands are kept entirely free from contact with its contents. The patent improved stopper is as durable as it is simple. Made of the best material, and carefully finished and adjusted. As a safeguard against loss by fire, this can is an economical and profitable "policy." Benzine is dangerous, but its use is divested of risk where this improved can is employed. It has been put to the test, and proved safe and serviceable in every respect. It may be overturned or placed in any position whatever, and the contents will not spill or overflow. There are no chains or exposed springs.

Approved by the Board of Fire Underwriters.

| | |
|----------------------|--------|
| Pint can | \$0 60 |
| Quart can | 0 75 |
| Gallon can | 2 00 |

TRUXELL BENZINE CAN.

Made of galvanized iron and exceptionally strong. Valve is located just above the handle and is easily operated by the thumb. It is recommended for use in large offices where a practical, indestructible can is a necessity.

| | |
|-------------------------------|--------|
| Quart size, net | \$1 00 |
| Two quart size, net | 1 25 |
| Gallon size, net | 1 50 |



Price List of Benzine Cans continued on following page.



**POOLE'S
PATENT
BENZINE
CAN.**

(The Original Benzine
Can.)

Well made of tin, with a stopper that prevents the fumes of the benzine escaping when can is not in use. The valve is operated by a weight inside of can.

Quart Size, only . \$0 50

ROLLER CLOTH.

In rolls 12 yds. long by 2½ inches wide, per roll . . . \$5 00

FELT BLANKETS.

| Width. | Thick. Per Yard. | Thin. Per Yard. |
|-----------------|------------------|-----------------|
| 36 inches . . . | \$7 20 | \$3 60 |
| 44 inches . . . | 8 80 | 4 40 |
| 54 inches . . . | 10 80 | . . . |

RUBBER BLANKETS.

| Size Bed. | Size Blanket. | Regular Thickness. |
|-------------|---------------|--------------------|
| 17×21 . . . | 19×20 . . . | Each, \$3 00 |
| 20×25 . . . | 23×24 . . . | Each, 4 25 |
| 21×27 . . . | 25×25 . . . | Each, 4 75 |
| 24×30 . . . | 28×28 . . . | Each, 5 75 |
| 25×35 . . . | 29×33 . . . | Each, 6 50 |
| 29×42 . . . | 34×40 . . . | Each, 8 75 |
| 32×46 . . . | 38×44 . . . | Each, 10 50 |
| 33×50 . . . | 38×47 . . . | Each, 11 75 |
| 36×52 . . . | 42×49 . . . | Each, 13 25 |
| 40×54 . . . | 46×53 . . . | Each, 17 00 |

RUBBER BLANKETS.

| | 2-Ply 1-16-Inch Thick. | 3-Ply 1-12-Inch Thick. | 5-Ply ½-Inch Thick. | Tympan Rubber. |
|------------------------------------|------------------------|------------------------|---------------------|----------------|
| 26 inches wide, per yard | \$5 00 | \$6 25 | \$7 25 | |
| 32 inches wide, per yard | 5 75 | 7 00 | 8 75 | |
| 34 inches wide, per yard | 6 25 | 7 50 | 9 75 | |
| 36 inches wide, per yard | 6 50 | 7 75 | 10 25 | \$1 25 |
| 38 inches wide, per yard | 7 25 | 8 50 | 11 25 | |
| 40 inches wide, per yard | 7 50 | 8 75 | 11 75 | |
| 44 inches wide, per yard | 8 50 | 10 00 | 13 50 | |
| 48 inches wide, per yard | 10 50 | 12 00 | 16 00 | |

TYMPAN PRESSBOARDS.

| | | | |
|------------------------------|--------|------------------------------|--------|
| 21×29 inches, each | \$0 50 | 35×52 inches, each | \$1 25 |
| 26×35 inches, each | 0 75 | 40×56 inches, each | 1 50 |
| 29×42 inches, each | 1 00 | | |

TAPE.

| | | | |
|----------------------------|--------|-------------------------------|--------|
| ¾-inch, per roll | \$0 75 | 1-inch, per roll | \$1 50 |
| ½-inch, per roll | 0 75 | 1½-inches, per roll | 1 60 |
| ⅝-inch, per roll | 1 00 | 1¼-inches, per roll | 1 75 |
| ¾-inch, per roll | 1 25 | 1½-inches, per roll | 2 00 |
| ⅞-inch, per roll | 1 40 | | |

A roll of tape contains thirty-six yards.

TAPE FASTENER.

Fastens tape with eyelets, which are neatly clinched by the fastener.

Price, with box of eyelets \$1 25



METALLIC TAPE COUPLERS.

This is a device for connecting ends of tape on presses and folding machines, so that there will be no wear at the joined parts, as is usual on sewed ends, which wear and cause the tape to run crooked and throw paper out of register. The Metallic Tape Coupler outlasts other methods of securing the ends of tape, and keeps the tape running true. It can be put on in a few seconds by means of parallel pliers made for that purpose.

PRICE PER BOX OF FIFTY.

| | |
|--------------------------------------|--------|
| No. 1, for 1/2-inch tape | \$1 25 |
| No. 2, for 5/8-inch tape | 1 50 |
| No. 3, for 3/4-inch tape | 1 50 |
| No. 4, for 7/8-inch tape | 1 75 |
| No. 5, for 1-inch tape | 1 75 |
| No. 6, for 1 1/8-inch tape | 1 75 |

SMOOTH-JAW PARALLEL PLIERS.

These pliers can be used for all sizes of couplers, per pair 1 00

PRINTERS' BRUSHES.

SOLID-BACK LYE BRUSH.

| | Per doz. | Each. |
|---------------------------------------|----------|--------|
| No. 20. Medium, all bristle | \$5 00 | \$0 50 |
| No. 30. Large, all bristle | 7 00 | 0 75 |
| No. 8. Medium, Tampico | 3 50 | 0 40 |
| No. 9. Large, Tampico | 4 50 | 0 50 |

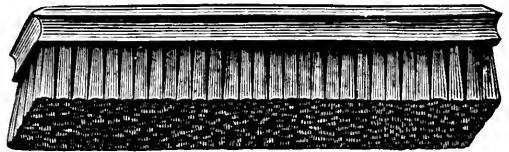

Furnished with handle at same price, if desired.

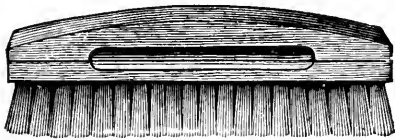

BENZINE BRUSH, OVAL BACK.

Benzine Brush, all bristle, oval back, genuine "pick" brush \$0 60

BENZINE BRUSH, WITH HANDLE.

Benzine Brush, all bristle \$0 40



STEREOTYPE BEATING BRUSHES.

| | |
|-------------------|--------|
| No. 120 | \$5 00 |
| No. 121 | 6 00 |
| No. 122 | 7 00 |

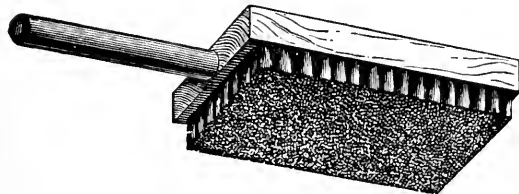

LIQUID CEMENT BRUSH.

Made of French bristles, flat and double thick.

| | |
|----------------------|--------|
| 1 inch | \$0 30 |
| 1 1/2 inch | 0 40 |
| 2 inch | 0 55 |
| 3 1/2 inch | 0 75 |

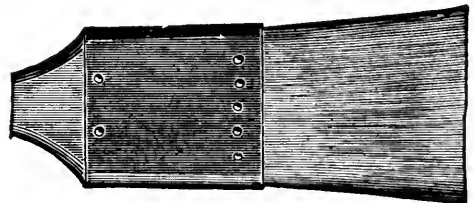

SMOOTH-LINED BRASS GALLEYS.

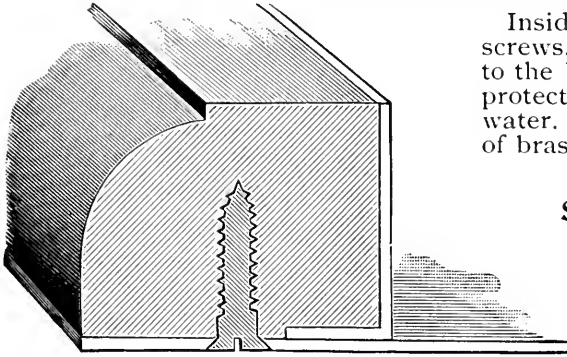

Sectional end view, showing how the brass lining protects the wood rim from action of lye and water.

Inside they are perfectly smooth and free from screws. The lining is angle brass, and is soldered to the bottom plate, strengthening the sides, and protecting the wood rim from the action of lye and water. The head is supported by a strong strip of brass.

SMOOTH-LINED JOB GALLEYS.

| | | |
|-------------------------------|------------------------------|--------|
| 6 | × 10 inches inside | \$2 00 |
| 8 ³ / ₄ | × 13 inches inside | 2 50 |
| 10 | × 16 inches inside | 3 00 |
| 12 | × 18 inches inside | 3 50 |
| 14 | × 20 inches inside | 4 00 |
| 15 | × 22 inches inside | 5 00 |
| 18 | × 25 inches inside | 5 75 |

SMOOTH-LINED COLUMN GALLEYS.

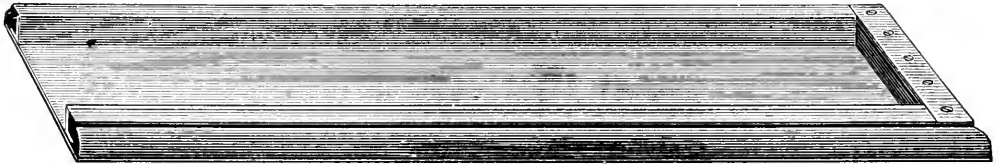

Smooth-lined Column Galley, showing Brass Plate at Head.

| | |
|--|--------|
| Single Column, brass-lined, 3 ¹ / ₂ × 23 ¹ / ₈ inches inside | \$2 00 |
| Single Column, brass-lined, 3 ¹ / ₂ × 11 ³ / ₈ inches inside | 1 50 |
| Medium width, brass-lined, 4 ³ / ₄ × 23 ¹ / ₈ inches inside | 2 25 |
| Double Column, brass-lined, 6 ¹ / ₄ × 23 ¹ / ₈ inches inside | 2 50 |
| Triple Column, brass-lined, 8 ¹ / ₂ × 23 ¹ / ₈ inches inside | 3 00 |
| Single Column, half-lined, 3 ¹ / ₂ × 23 ¹ / ₈ inches inside | 1 75 |
| Double Column, half-lined, 6 ¹ / ₄ × 23 ¹ / ₈ inches inside | 2 25 |

UNLINED GALLEYS.

ZINC BOTTOM.

| | |
|---|--------|
| Single Column, 3 ¹ / ₂ × 23 ¹ / ₈ inches inside | \$1 25 |
| Double Column, 6 ¹ / ₄ × 23 ¹ / ₈ inches inside | 1 50 |

BRASS BOTTOM.

| | |
|---|--------|
| Single Column, 3 ¹ / ₂ × 23 ¹ / ₈ inches inside | \$1 50 |
| Double Column, 6 ¹ / ₄ × 23 ¹ / ₈ inches inside | 2 00 |

CLOSED-END MAILING GALLEYS.



THE HAMILTON MFG. CO.

| | |
|--|--------|
| 6 ¹ / ₄ × 23 ¹ / ₂ inches inside, closed ends, all brass, each | \$3 25 |
| 7 ¹ / ₄ × 23 ¹ / ₂ inches inside, closed ends, all brass, each | 3 50 |
| 6 ¹ / ₄ × 22 ¹ / ₄ inches inside, closed ends, brass lined, each | 3 00 |
| 10 × 22 ¹ / ₄ inches inside, closed ends, brass lined, each | 4 00 |
| 2 ⁷ / ₈ × 24 inches inside, closed ends, brass lined, each | 2 25 |
| 6 ¹ / ₄ × 22 ¹ / ₄ closed ends, zinc bottom, unlined, each | 1 50 |

SUCCESS RIVETED ALL-BRASS GALLEYS.

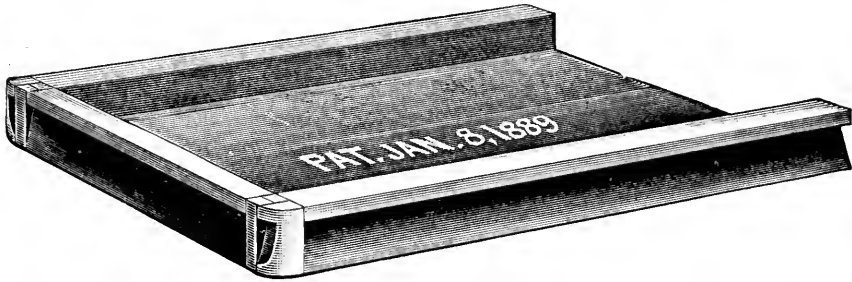

Made of heavy brass, the sides *riveted* strongly to the bottoms, and the corners locked together by a patented hold, which effectually resists all the strain of locking-up. These galleys will be found to be a great improvement over those galleys with bottoms screwed to the sides. The list prices remain the same as charged for

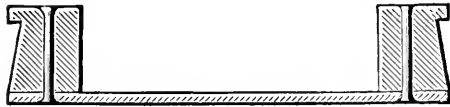

Shows method of securing sides to bottom by rivets.



Shows patent corner hold.

galleys with bottom secured by screws. These galleys have been the standard for quality and construction for several years, and are still unexcelled.

ALL-BRASS COLUMN GALLEYS.

| | |
|---|---|
| Single, 3¾ × 23¾ inches inside . . . \$2 00 | Double, 6¼ × 23¾ inches inside . . . \$2 50 |
| Single, 3¾ × 11¾ inches inside . . . 1 50 | Triple, 8¼ × 23¾ inches inside . . . 3 25 |
| Medium, 5 × 23¾ inches inside . . . 2 25 | |

ALL-BRASS JOB GALLEYS.

| | |
|---------------------------------------|--|
| 6 × 10 inches inside \$1 50 | 12 × 18 inches inside \$3 75 |
| 8¾ × 13 inches inside 2 00 | 14 × 21 inches inside 4 50 |
| 9 × 14 inches inside 2 50 | 15 × 22 inches inside 5 00 |
| 10 × 16 inches inside 3 00 | 18 × 25 inches inside 6 00 |

MAILING GALLEYS.

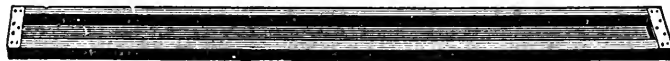

Mustang Mailing Galley.

| |
|--|
| Mustang Mailing Galley, zinc bottom \$0 50 |
| Mustang Mailing Galley, brass bottom 0 75 |

WOODEN GALLEYS.



| |
|--------------------------------------|
| 5 × 8 inches inside \$0 25 |
| 5 × 15 inches inside 0 30 |
| 5½ × 18 inches inside 0 40 |
| 6 × 10 inches inside 0 30 |
| 6½ × 24 inches inside 0 60 |
| 7 × 22 inches inside 0 55 |
| 8 × 10 inches inside 0 40 |
| 8 × 24 inches inside 0 60 |
| 10 × 16 inches inside 0 65 |
| 9 × 18 inches inside 0 70 |
| 10 × 24 inches inside 0 75 |
| 3½ × 24 inches inside 0 50 |

LAING PATENT GALLEY LOCK-UP.

Attachable to all Brass, Smooth Lined, and Patent Lined Galleys.

A satisfactory, simple, effective lock-up. It may be screwed on any galley; the side stick (which is not beveled) is attached to the lock-up, and has a parallel motion. It is locked or unlocked by pushing the lever up or down by means of a finger knob. The lock-up and the side stick are made of brass.

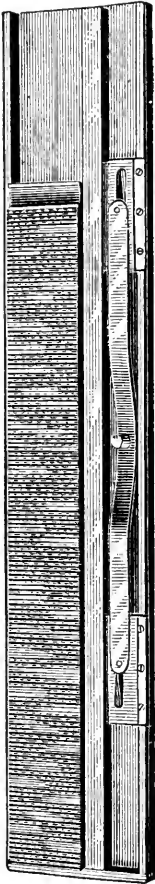

* COLUMN GALLEYS, WITH LOCK-UP.

| | Price of Galley. | *Price of Lock-up. | Complete. |
|--|------------------|--------------------|-----------|
| 3 3/4 x 23 3/4 inches inside | \$2 00 | \$1 50 | \$3 50 |
| 3 3/4 x 15 3/4 inches inside | 1 75 | 1 40 | 3 15 |
| 3 3/4 x 11 3/4 inches inside | 1 50 | 1 30 | 2 80 |
| 5 x 23 3/4 inches inside | 2 25 | 1 50 | 3 75 |
| 6 1/4 x 23 3/4 inches inside | 2 50 | 1 50 | 4 00 |
| 6 1/4 x 15 3/4 inches inside | 2 25 | 1 40 | 3 65 |
| 6 1/4 x 11 3/4 inches inside | 2 00 | 1 30 | 3 30 |
| 8 1/4 x 23 3/4 inches inside | 3 25 | 1 50 | 4 75 |

* JOB GALLEYS, WITH LOCK-UP.

| | Price of Galley. | *Price of Lock-up. | Complete. |
|------------------------------------|------------------|--------------------|-----------|
| 6 x 10 inches inside | \$1 50 | \$1 25 | \$2 75 |
| 8 3/4 x 13 inches inside | 2 00 | 1 30 | 3 30 |
| 9 x 14 inches inside | 2 50 | 1 35 | 3 85 |
| 10 x 16 inches inside | 3 00 | 1 40 | 4 40 |
| 12 x 18 inches inside | 3 75 | 1 45 | 5 20 |
| 14 x 21 inches inside | 4 50 | 1 50 | 6 00 |
| 15 x 22 inches inside | 5 00 | 1 50 | 6 50 |
| 18 x 25 inches inside | 6 00 | 1 60 | 7 60 |

*If Galley Lock-up is sold separately, the necessary screws for attaching to galley are included in prices given.

PATENT LINOTYPE GALLEY.

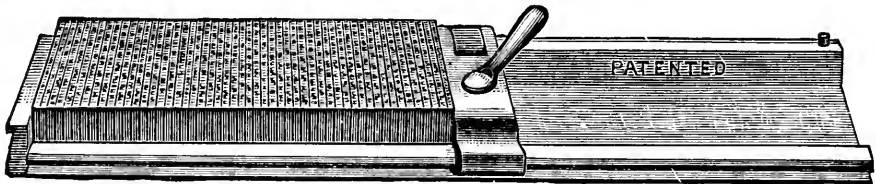

This new patent galley is made solely for linotypes, and is the only galley for holding linotype slugs without any side lock-up. A foot clamp is attached to each galley to hold up the matter in taking proofs. This galley will save all the trouble and the loss of time in handling side sticks, getting quoins to fit, or foot slugs to keep the end line from falling over. One side of the galley is made lower, and the inside of the rims so tapered as to allow inserting and taking out the linotype slugs from the side very readily. The galley being only one-half of an inch wider than the matter, is conveniently handled and can be placed on the stone, rack or case without taking

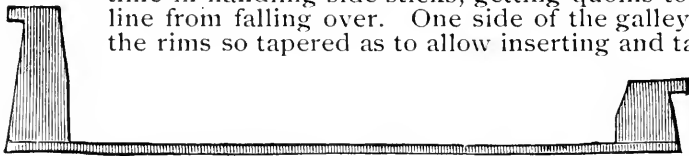

End view, 13 ems wide inside.

up valuable space. On a crowded imposing table, in the rush of making-up, the saving of space is of great importance.

| | |
|--|--------|
| 12 inch, all-brass news galley, for 16 ems or under† | \$2 00 |
| 16 inch, all-brass news galley, for 16 ems or under | 2 25 |
| 24 inch, all-brass news galley, for 16 ems or under | 2 50 |
| Extra foot clamps, each | 0 50 |

Other sizes made to order. Above prices include foot clamp.

† In ordering, give the measure of column width, as galleys are supplied to take one measure only, not exceeding 16 ems; also send a sample linotype slug.

LINCOLN ALL-BRASS GALLEYS.

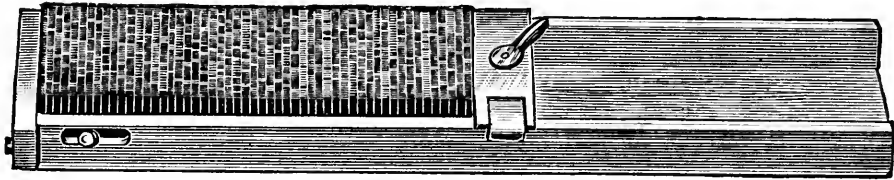

Shows the Galley locked at end and side.

A good galley for newspaper work. *Made to order* to hold any regular widths of matter in regular use in an office. The upper side or rim of galley is strongly hinged to the bottom.

This hinged side is dropped when emptying on galley, and when matter is ready for locking up the side is raised and is held by a spring-catch at head of galley

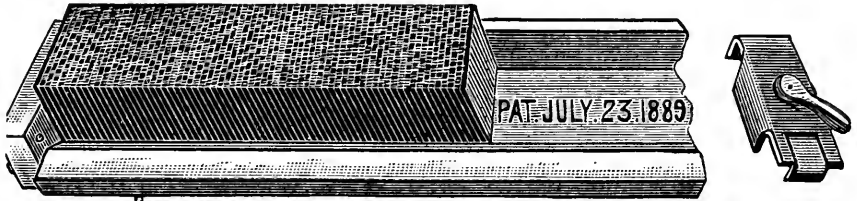

Shows the Galley unlocked, with end lock detached.

and by the end clamp which locks the sides and end at the same operation. The catch is loosened by turning lever to the right. These galleys are about one inch wider than the width of column they are made to take.

| | | | |
|-----------------------------------|--------|-----------------------------------|--------|
| 12-inch News, all brass | \$2 00 | 24-inch News, all brass | \$3 00 |
| 16-inch News, all brass | 2 50 | 24-inch Book, all brass | 3 50 |

In ordering, give exact width of columns.

PLATE ZINC STORAGE GALLEYS.

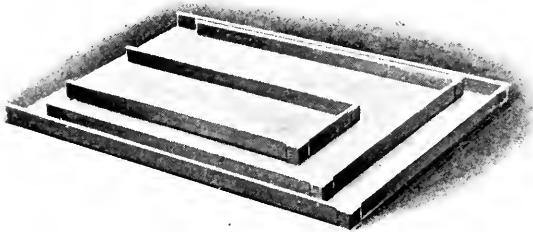

These galleys are shaped in special moulds, the corners reinforced, making them very substantial and durable. They are especially desirable for storage purposes where machine type-setting and Linotype machines are used. The material used is double-rolled plate zinc, especially made for this purpose.

| | |
|--|--------|
| Single column, $3\frac{1}{2} \times 23\frac{1}{8}$ inches inside, each | \$1 00 |
| Double column, $6\frac{1}{4} \times 23\frac{1}{8}$ inches inside, each | 1 25 |

MAY'S PATENTED LEADER AND SORT BOX.

It occupies a most convenient position on the lower case, thus avoiding the long reach to the upper case. Covering just half the lower-case "e" box, and utilizing all spaces of partitions, etc., it does not obstruct the free use of a single sort in either case. The steel points on under side and two side arms hold the box firmly in position, with no danger of its being upset. The box is made to fit the only place a box can occupy on the case without covering copy or any of the sorts. (See location of box in illustration.)

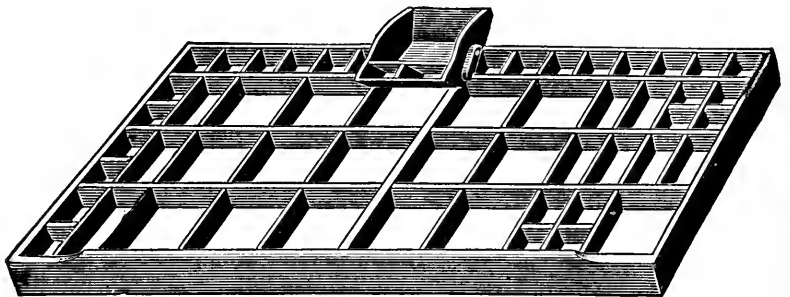

| | | | |
|-------------------------|--------|---------------------|--------|
| Price, single | \$0 50 | Per dozen | \$5 00 |
|-------------------------|--------|---------------------|--------|

MAHOGANY AND IRON STEREOTYPE BLOCKS.

Mahogany Blocks are made of the best San Domingo mahogany, thoroughly seasoned, and are first-class in every detail. All blocks are made to order at short notice.

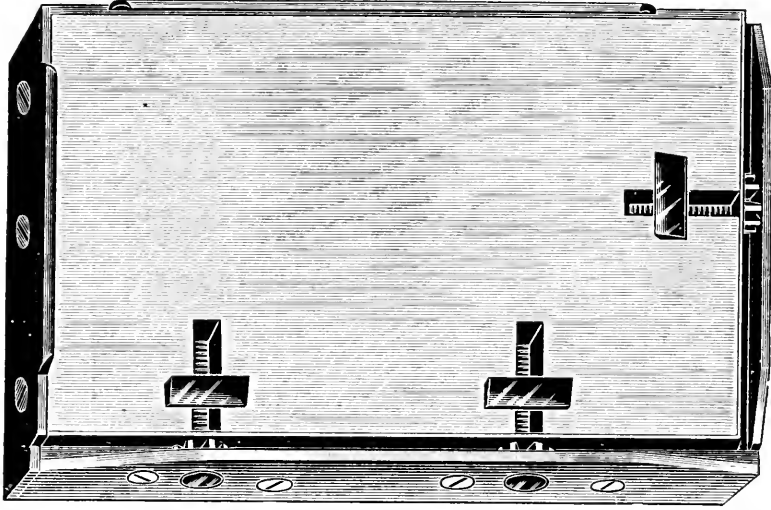

New Style Block, with Improved Side and End Hooks.

IMPORTANT POINTS.

Do not order a set of blocks, nor make up a form of patent blocks for press, until you know the exact size of chase that must hold the blocks, and the thickness and position of its cross-bars. Ascertain also the exact size of paper for which the blocks are intended, and whether the leaves of paper, after printing, are to be cut or uncut, and to be sewed or stitched. In making up blocks, if paper is to be uncut and sewed, allow nothing for loss by waste on the fore edge; if it is to be side-stitched and trimmed, make suitable allowance for margin that will be concealed by wire stitching in binding.

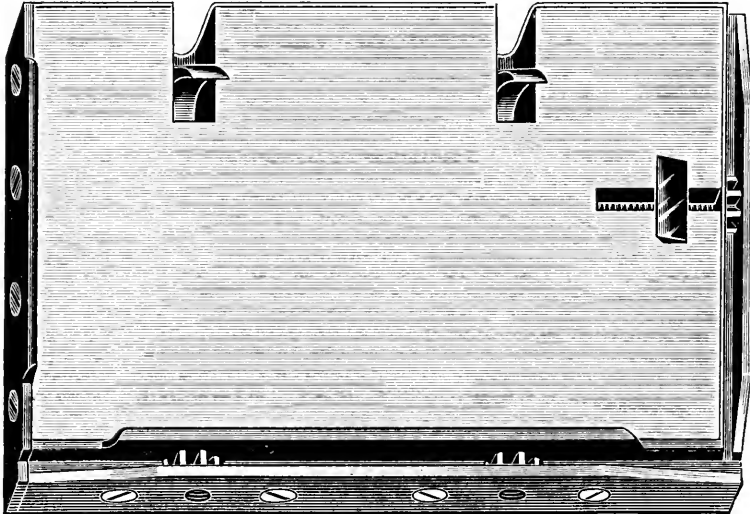

Plain Old Style Block.

CAUTION—To Avoid Errors. In sending orders, give the size of each block outside, and also the size of largest and smallest plate to be worked, *measuring the back of the plate*; or add $\frac{3}{4}$ of an inch to the printing matter, as follows, viz.: If the matter is 3×5 , the blocks should be $3\frac{3}{4} \times 5\frac{3}{4}$ outside, the bevel on the plate being about $\frac{1}{8}$. The hook and pin will take $\frac{3}{8}$ with a little allowance for taking the plate free. All blocks are made $\frac{3}{4}$ -inch thick, unless otherwise ordered.

PRICE LIST OF MAHOGANY STEREOTYPE BLOCKS WITHOUT END HOOKS.

For Platen Presses.

To get the price of blocks with head brass, but no end hook, take the price of the next largest size in Price List. Add 50 cents each for extra hooks and pinions inserted in blocks.

| SIZE. | Outside Dimensions of Blocks. | *Size of Smallest Plate incl'd'g Bevel. | No. of Side Hooks. | Imp. Plain Old Style. | Patent New Style. | Patent New Style Iron. | Proper Number of Blocks to Work a Sheet of Paper. |
|-----------------------|-------------------------------|---|--------------------|-----------------------|-------------------|------------------------|---|
| Folio— | | | | | | | |
| Imperial | 16 × 22½ | 14¾ × 21¼ | 4 | \$5 00 | \$6 25 | \$16 00 | 4 blocks to 33×46 |
| Super-Royal | 13½ × 21½ | 12¼ × 20¼ | 4 | 4 55 | 5 70 | 15 00 | 2 blocks to 22×28 |
| Royal | 12½ × 19½ | 11¼ × 18¼ | 4 | 4 20 | 5 25 | 14 00 | 4 blocks to 26×40 |
| Medium | 11½ × 18½ | 10¼ × 17¼ | 4 | 3 90 | 4 80 | 13 00 | 4 blocks to 24×38 |
| Quarto— | | | | | | | |
| Imperial | 11 × 16 | 9¾ × 14¾ | 4 | 3 75 | 4 50 | 12 00 | 8 blocks to 33×46 |
| Super-Royal | 10½ × 13½ | 9¼ × 12¼ | 3 | 3 10 | 3 75 | 10 50 | 4 blocks to 22×28 |
| Royal | 9½ × 12½ | 8¼ × 11¼ | 3 | 2 95 | 3 50 | 10 00 | 8 blocks to 26×40 |
| Medium | 9 × 11½ | 7¾ × 10¼ | 3 | 2 80 | 3 30 | 9 50 | 8 blocks to 24×38 |
| Octavo— | | | | | | | |
| Imperial | 7¾ × 11 | 6½ × 9¾ | 3 | 2 65 | 3 10 | 9 00 | 16 blocks to 33×46 |
| Super-Royal | 6½ × 10½ | 5¼ × 9¼ | 3 | 2 50 | 2 90 | 8 50 | 8 blocks to 22×28 |
| Royal | 6 × 9½ | 4¾ × 8¼ | 3 | 2 40 | 2 75 | 8 00 | 16 blocks to 26×40 |
| Medium | 5½ × 9 | 4¼ × 7¾ | 3 | 2 30 | 2 60 | 7 75 | 16 blocks to 24×38 |
| Demy | 5¼ × 7¾ | 4 × 6½ | 3 | 2 20 | 2 45 | 7 50 | 32 blocks to 33×46 |
| Duodecimo— | | | | | | | |
| Broad | 5¼ × 6¾ | 4 × 5½ | 2 | 1 65 | 1 90 | .. | 24 blocks to 23×41 |
| 16mo— | | | | | | | |
| Super-Royal | 5 × 6½ | 3¾ × 5¼ | 2 | 1 50 | 1 70 | .. | 16 blocks to 22×28 |
| Medium | 4½ × 6 | 3¼ × 4¾ | 2 | 1 40 | 1 60 | .. | 32 blocks to 26×40 |
| Demy | 3¾ × 5¼ | 2½ × 4 | 2 | 1 30 | 1 50 | .. | 32 blocks to 23×33 |
| 18mo— | | | | | | | |
| Medium | 3½ × 5¾ | 2¼ × 4½ | 2 | 1 30 | 1 50 | .. | 18 blocks to 19×24 |
| 32mo— | | | | | | | |
| Super-Royal | 3 × 5 | 1¾ × 3¾ | 2 | 1 20 | 1 40 | .. | 32 blocks to 22×28 |

* A block will take on a plate ⅝-inch smaller each way than the outside dimensions of the plate.

PRICE LIST OF MAHOGANY STEREOTYPE BLOCKS WITH END HOOKS.

For Cylinder Presses.

See "Caution" and other information on opposite page before ordering.

| SIZE. | Outside Dimensions of Blocks. | *Size of Smallest Plate incl'd'g Bevel. | No. of Side Hooks. | No. of End Hooks. | Imp. Plain Old Style. | Patent New Style. | Patent New Style Iron. | Proper Number of Blocks to Work a Sheet of Paper. |
|-----------------------|-------------------------------|---|--------------------|-------------------|-----------------------|-------------------|------------------------|---|
| Folio— | | | | | | | | |
| Imperial | 16 × 22½ | 14¾ × 21¼ | 4 | 3 | \$7 25 | \$8 50 | \$21 00 | 4 blocks to 33×46 |
| Super-Royal | 13½ × 21½ | 12¼ × 20¼ | 4 | 3 | 6 80 | 7 95 | 19 50 | 2 blocks to 22×28 |
| Royal | 12½ × 19½ | 11¼ × 18¼ | 4 | 3 | 6 40 | 7 45 | 18 25 | 4 blocks to 26×40 |
| Medium | 11½ × 18½ | 10¼ × 17¼ | 4 | 3 | 6 10 | 7 00 | 17 25 | 4 blocks to 24×38 |
| Quarto— | | | | | | | | |
| Imperial | 11 × 16 | 9¾ × 14¾ | 4 | 2 | 5 30 | 6 10 | 15 00 | 8 blocks to 33×46 |
| Super-Royal | 10½ × 13½ | 9¼ × 12¼ | 3 | 2 | 4 50 | 5 25 | 13 50 | 4 blocks to 22×28 |
| Royal | 9½ × 12½ | 8¼ × 11¼ | 3 | 2 | 4 25 | 4 90 | 12 75 | 8 blocks to 26×40 |
| Medium | 9 × 11½ | 7¾ × 10¼ | 3 | 2 | 4 00 | 4 60 | 12 25 | 8 blocks to 24×38 |
| Octavo— | | | | | | | | |
| Imperial | 7¾ × 11 | 6½ × 9¾ | 3 | 1 | 3 30 | 3 80 | 10 75 | 16 blocks to 33×46 |
| Super-Royal | 6½ × 10½ | 5¼ × 9¼ | 3 | 1 | 3 15 | 3 60 | 10 00 | 8 blocks to 22×28 |
| Royal | 6 × 9½ | 4¾ × 8¼ | 3 | 1 | 3 00 | 3 40 | 9 50 | 16 blocks to 26×40 |
| Medium | 5½ × 9 | 4¼ × 7¾ | 3 | 1 | 2 85 | 3 25 | 9 00 | 16 blocks to 24×38 |
| Demy | 5¼ × 7¾ | 4 × 6½ | 3 | 1 | 2 70 | 3 10 | 8 50 | 32 blocks to 33×46 |
| Duodecimo— | | | | | | | | |
| Broad | 5¼ × 6¾ | 4 × 5½ | 2 | 1 | 2 05 | 2 45 | .. | 24 blocks to 23×41 |
| 16mo— | | | | | | | | |
| Super-Royal | 5 × 6½ | 3¾ × 5¼ | 2 | 1 | 1 95 | 2 30 | .. | 16 blocks to 22×28 |
| Medium | 4½ × 6 | 3¼ × 4¾ | 2 | 1 | 1 85 | 2 15 | .. | 32 blocks to 26×40 |
| Demy | 3¾ × 5¼ | 2½ × 4 | 2 | 1 | 1 75 | 2 00 | .. | 32 blocks to 23×33 |
| 18mo— | | | | | | | | |
| Medium | 3½ × 5¾ | 2¼ × 4½ | 2 | 1 | 1 75 | 2 00 | .. | 18 blocks to 19×24 |
| 32mo— | | | | | | | | |
| Super-Royal | 3 × 5 | 1¾ × 3¾ | 2 | 1 | 1 65 | 1 85 | .. | 32 blocks to 22×28 |

* A block will take on a plate ⅝-inch smaller each way than the outside dimensions of the plate.

See following page for Price List of Stereotype Sectional Metal Blocks.

WESEL PATENT IRON GROOVED BLOCK

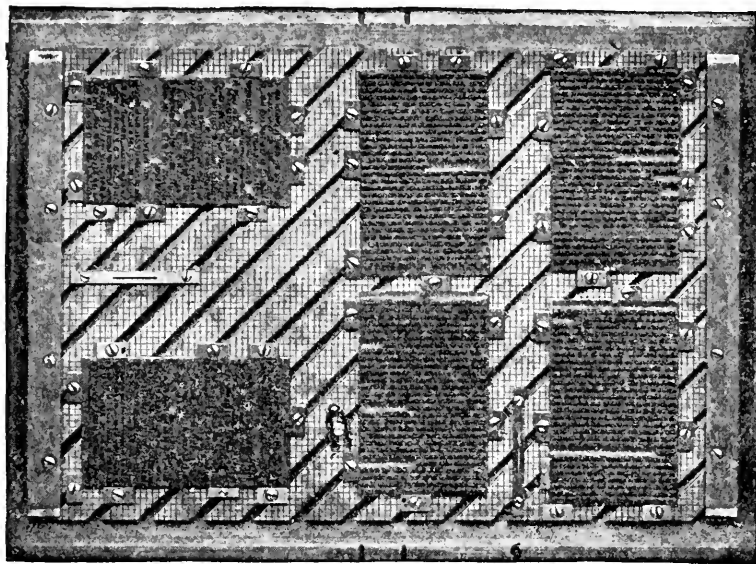

Wesel Patent Iron Grooved Block for Cylinder and Job Presses. This illustration shows the block made to fit job press without chase.

Completely meets the most exacting demands of those who print from plates, especially on three-color process work, and where close register is essential. It is a solid iron block, usually made to cover the maximum printing capacity of a press, $\frac{3}{4}$ -inch high, lined over its surface in squares of one Pica, with diagonal grooves cut in it one inch apart. In these grooves patent hooks are placed in such a way that they will hold any size of plate, allowing very close margins if necessary. No chase or furniture of any kind is needed with this block. Register is obtained quickly and positively. Points for folding machines of all makes are furnished, and can be placed in the correct positions. These blocks are also made for job presses, and in that case roller bearers are attachable, as shown in illustration.

Prices on application. State size of bed of press for which block is required, and also maximum size of form press will print.

STEREOTYPE SECTIONAL METAL BLOCKS

Consist of metal sections, made up of pieces 2x4, 2x8, 4x4, 4x8, and 8x8 ems Pica. Hooks are inserted in the largest sections, which may be arranged on any part of the block, and can be adapted for bed and platen or cylinder presswork. With an assortment of the sections or furniture the printer may, by a proper combination, prepare a set of blocks to take on a page of any size. The weight required for a page can be readily estimated by figuring $3\frac{1}{2}$ ounces to each square inch of back of plate. To extend size of sectional block, in case there is a shortage of sections, metal furniture not exceeding two ems Pica wide may be used. Our standard sectional blocks are made to take plates 11 points in thickness.

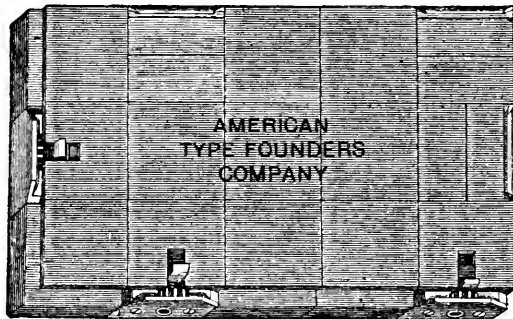

Sections with regular margin hook, each, \$1 00 | Brass catches, each \$0 15
 Sections with narrow margin hook, each, 1 10 | Sections or furniture, per pound . 0 25

CHALLENGE NARROW-MARGIN BRASS REGISTER HOOKS

For Three-Color Printing.

These hooks are intended for color printing. Six hooks to each average-size plate. They are placed on all sides of the plate, and by use of a small key the hook on one side is released, and the one opposite is tightened. By this means a plate may be moved the smallest fraction of an inch, and as each plate is registered independently it will be readily understood how easily and quickly a whole form of plates may be made to register absolutely.

We furnish to order sectional blocks in brass or iron, and all kinds of special combination blocks for book and color printing. Estimates on application.

Brass Register Hooks, each 6x6 ems,
 net \$1 25

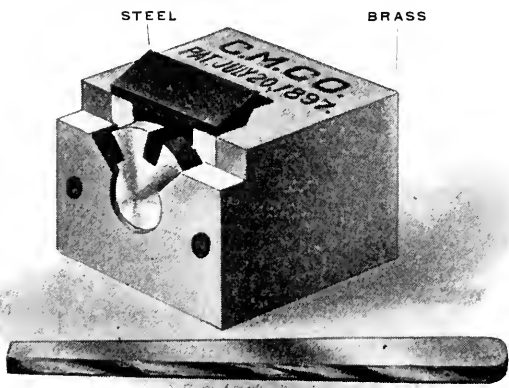

WEATHERLY EXTENSION BLOCKS.

IRON OR MAHOGANY.

Takes on a Plate any Size. Has all the Good Qualities of the Old-time Patent Stereotype Block and the Great Advantage of being Adjustable to Plates of Various Sizes.

The material and workmanship employed in the manufacture of these Blocks are the very best obtainable. They are made with the utmost precision and are in the front rank of modern inventions for producing the best results in printing.

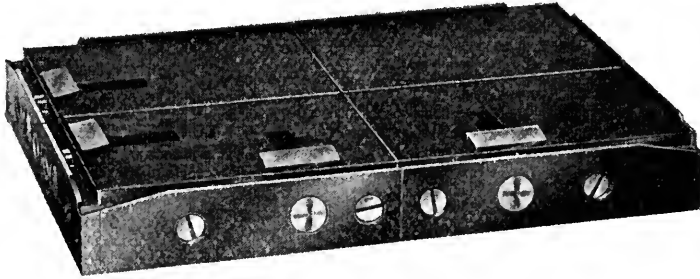

Fig. 1.—Block Without Extensions.

The cut (Fig. 1) shows the Block without extensions. The four corner sections are separate and made to a standard size, each measuring 2×3 inches, and when placed together, forming the Block as shown, they measure 4×6 inches, and will take on a plate any size from $2\frac{3}{8} \times 4\frac{5}{8}$ to $3\frac{3}{8} \times 5\frac{7}{16}$ inches.

It is often necessary to work narrow margins on plates of small size, and in such cases the Parallel Strips for increasing the Blocks slightly, as by Picas, can be used to great advantage. There are twenty-eight of these strips for each Block, viz.: two pieces each, 1 and 2 ems Pica wide by 12, 18, 24, 36, 37, 38 and 39 Picas long. They are accurately made with rabbeted end (so as not to interfere with the ratcheting), and by their use the Block can be increased in width or length, or both, from one to six ems Pica, beyond which sizes the Crosses meet every requirement.

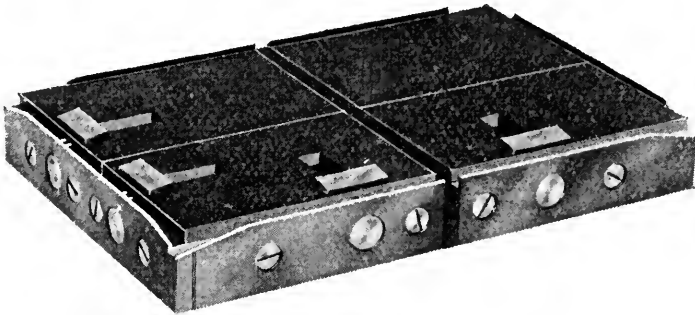

Fig. 2.—Block Extended in Length Only.

The cut (Fig. 2) shows the Block increased one Pica in length with a Parallel Strip. This can be increased to one inch without altering the width, if desired. Long, narrow plates are easily provided for in this manner. Printers will thoroughly appreciate this easy method of overcoming difficulties heretofore experienced with Blocks "a little too large" or "a bit too small."

There is not only a great deal of satisfaction in having on hand a set of Blocks that will take plates of any size that may come along, but there is obviously great economy in such Blocks. Often profitable work is turned away on account of not having Blocks of the necessary size, particularly if it happens to be an odd size seldom used. Other work is lost by not having Blocks of the desired size nor the time to order them specially made. All of this is a thing of the past—the printer having a set of Weatherly Extension Blocks is always ready, and if he has not purchased them they can be had promptly from stock, in mahogany or iron, at any time.

WEATHERLY EXTENSION BLOCKS.

(Continued.)

The cut (Fig. 3) shows the Block extended, in width only, by use of a Parallel Strip 1 Pica wide by 36 Picas long. This can be increased to one inch without altering the length, thus taking on short, wide plates very conveniently.

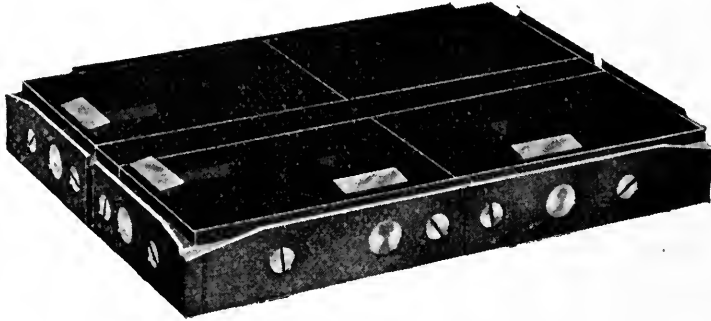

Fig. 3.—Block Extended in Width Only.

The three Crosses shown as Fig. 6 are the principal extensions, and fully meet the requirements in all cases, except where narrow margins must be worked. Cross A is $4\frac{1}{2} \times 6\frac{3}{4}$ inches outside, and when used with the corner sections will take any size plate from $3\frac{1}{8} \times 5\frac{5}{8}$ to $3\frac{3}{8} \times 6\frac{3}{16}$ inches. Cross B is $5\frac{1}{4} \times 7\frac{3}{4}$ inches, and with the corner sections takes plates any size from $3\frac{3}{8} \times 6\frac{3}{8}$ to $4\frac{11}{16} \times 7\frac{3}{16}$ inches. Cross C is 6×9 inches, and with corner sections will take plates any size from $4\frac{5}{8} \times 7\frac{5}{8}$ to $5\frac{3}{8} \times 8\frac{7}{16}$ inches. It will be seen that the three regular-size Crosses cover all size plates from $2\frac{5}{8} \times 4\frac{5}{8}$ to $5\frac{3}{8} \times 8\frac{7}{16}$ inches, and all above sizes can be increased at least one Pica each way by using the Pica Parallel Strips in connection with the Crosses.



Fig. 4.—Block Extended Proportionately with Cross.

The cut (Fig. 4) shows the Block extended proportionately by use of Cross A, forming a complete Block $4\frac{1}{2} \times 6\frac{3}{4}$ inches outside. All the Crosses are accurately made, and the corner sections fit snugly. The Block will lock up in a form as well as if made in one solid piece.

No cuts showing Block with Crosses B and C are printed herewith as they are exactly like Cross A, except in sizes, which are given elsewhere.

The cut (Fig. 5) shows Block with a Cross of special large size and extra hook and clamp. In cases where it is desired to work an unusually large plate beyond the scope of Cross C, special Crosses of the size desired must be made to order. There is no limit to the size of special Crosses, which will be supplied promptly at moderate cost. In ordering them give the size of the printed page (type matter) or back measurement of plate to be worked. If hooks and clamps are desired on Crosses, be careful to state the number wanted. Prices of special Crosses, with or without hooks and clamps, quoted upon application.

WEATHERLY EXTENSION BLOCKS.

(Continued.)

The cut (Fig. 6) shows three Extension Crosses, the larger one with hook and clamp. The four recesses in the Crosses are accurately made to a standard size, viz.: 2×3 inches, and the corner sections may always be relied upon to fit any regular or special Cross perfectly.

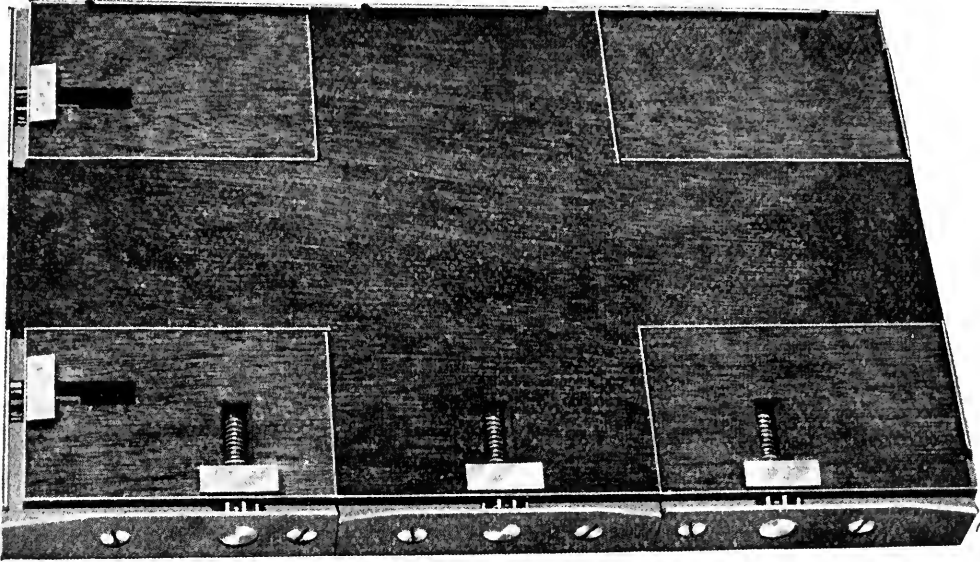

Fig. 5.—Block with Special Large Cross, showing Extra Hook and Clamp.

There are an equal number of right and left Crosses with each set of Blocks, and they are distinctly marked *R* and *L*, the same as the corner sections, to simplify and facilitate making up the Blocks in forms. The mahogany Crosses are cut out of a solid block of wood, and made with special machinery built to secure the utmost accuracy. While simple in appearance they require the greatest care in manufacturing, and are examined and gauged before being sent out from the factory.

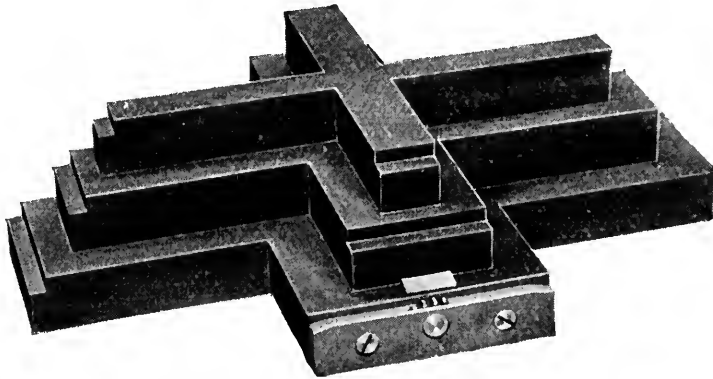

Fig. 6.—Three Extension Crosses.

The cut (Fig. 7) shows a set of thirty-two Blocks, complete with Crosses and Parallel Strips, in a substantial and handsomely made cabinet specially designed to hold them to the best advantage and save them from being lost or damaged. Sets of sixteen Blocks are put up in smaller cabinets in the same manner. The Corner Pieces and Crosses all rest on their edges when in the cabinet, and while in this position are not likely to be affected in any way by undue heat or moisture, as might be the case if left to lay flat on their sides when not in use. The cabinets also contain three compartments for ratchets, etc.

WEATHERLY EXTENSION BLOCKS.

(Continued.)

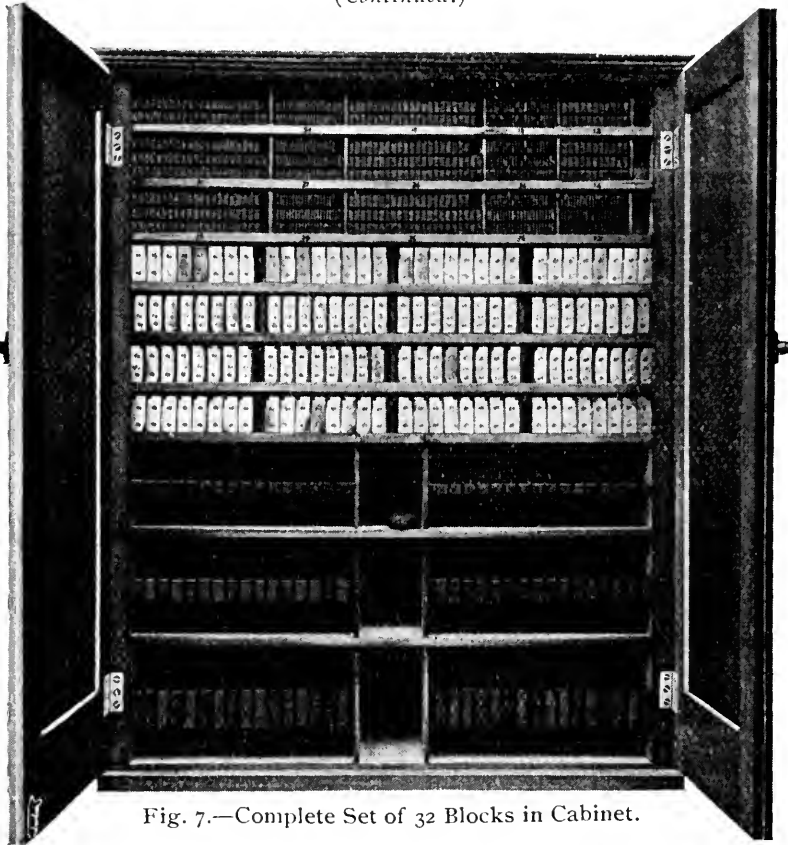

Fig. 7.—Complete Set of 32 Blocks in Cabinet.

The Iron Weatherly Extension Blocks differ from the Mahogany Blocks in material only. The four Corner Sections and largest Cross are made of iron, the hooks and clamps are brass, and the two small Crosses and Parallel Strips are made of steel bars, all highly finished in a most superior, workmanlike manner.

The Iron Blocks produce the very best results and save much time in making ready, the underlays on the back of plates being more effective when placed between the plate and the rigid iron base. They meet every possible requirement in printing book plates and half-tones. These Blocks are very serviceable in job offices having long runs of circulars, etc., where two, four or eight are run to a sheet, only requiring plates to be made, which are much cheaper than electrotypes mounted on wood. A set of four or eight of these Blocks will soon pay for themselves by the saving on electrotyping and presswork only.

BLOCK WITH DIFFERENT EXTENSIONS.

| | Block Without Extensions. | With Cross A. | With Cross B. | With Cross C. |
|---|---------------------------|-----------------------|--|-----------------------|
| Outside dimensions of Blocks | 4 × 6 | 4½ × 6¾ | 5¼ × 7¾ | 6 × 9 |
| Largest Plate, including Bevel | 3¾ × 5¾ ¹⁶ | 3¾ × 6¾ ¹⁶ | 4 ¹¹ / ₁₆ × 7¾ ¹⁶ | 5¾ × 8¾ ¹⁶ |
| Smallest Plate, including Bevel | 2½ × 4½ | 3½ × 5½ | 3¾ × 6¾ | 4½ × 7½ |

PRICE LIST.

| | |
|--|--------|
| Mahogany Block, without Extensions | \$3 00 |
| Iron Block, without Extensions | 6 00 |

Extensions may be purchased as required at following prices: Mahogany. Iron.

| | | |
|---|--------|--------|
| Crosses A and B, each | \$0 50 | \$1 00 |
| Cross C, each | 0 50 | 1 25 |
| Set of Parallel Strips (for each Block) | 0 50 | 1 50 |

Cabinets for 16 Blocks, \$10 00; Cabinets for 32 Blocks, \$15 00.

Four sets of ordinary Stereotype Blocks, at an additional cost of 60 per cent., are required to work the same number and sizes of plates taken on by one set of sixteen Weatherly Extension Blocks.

No more waiting for Blocks to be made to order. These are carried in stock for immediate delivery.

THE VIERLING PATENT TIE-UP.

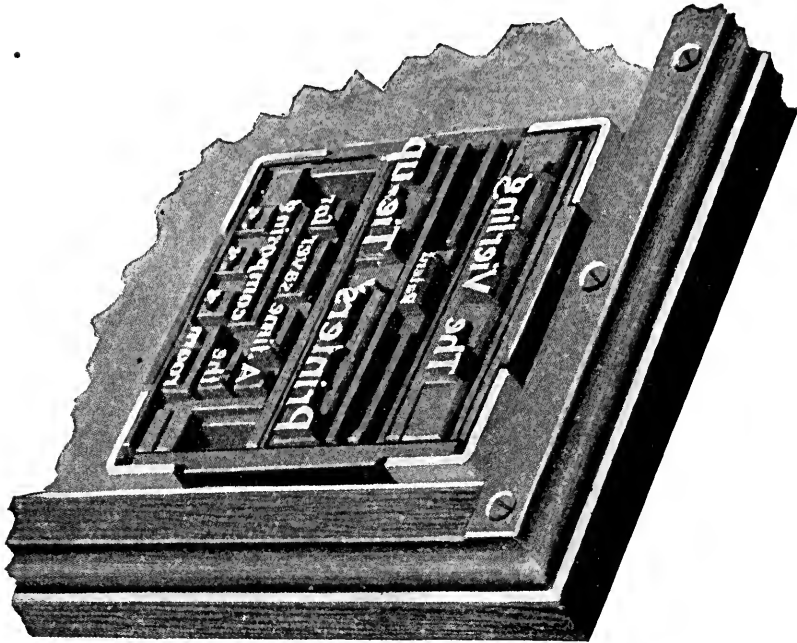

This is a new labor-saving device for use in the composing room to take the place of page cord. It is not removed from the job or pages when locked into a chase. It can be applied more quickly than cord, and will secure the job or page of type more firmly. When the job is off press and unlocked, it can be set aside without further attention.

For catalogue work, railroad time-tables and rule and figure work, which require changing from time to time, it will greatly facilitate the handling, as forms can be taken apart rapidly and the pages given out to a number of hands for correction.

The Vierling Patent Tie-up is made of steel, exact Pica thick, with brass corner pieces, and is gauged to Pica measurement.

Job fonts contain one square each from twelve to twenty Pica ems inclusive, and one square each of even sizes from twenty-two to sixty-six ems Pica inclusive. The parts being interchangeable, any size between those given can be formed.

Book fonts contain thirty-two complete tie-ups in regular sizes, as given below. Special sizes made to order at regular font rates.

SIZES :

Single job font, 32 sizes, one square each size.

Double job font, 32 sizes, two squares each size.

This will give two and four pages of all sizes except squares.

Book fonts, 38×50 Picas, thirty-two complete tie-ups.

Book fonts, 26×46 Picas, thirty-two complete tie-ups.

Book fonts, 24×42 Picas, thirty-two complete tie-ups.

Book fonts, 16×24 Picas, thirty-two complete tie-ups.

| | |
|---|---------|
| Price, per single font, job or book | \$ 9 00 |
| Price, per double font, job or book | 18 00 |
| Corner pieces, per set of four | 10 |

BESSEMER STEEL CHASES.

These Chases are Unexcelled for Accuracy, Squareness and Strength.

The material used to make these chases is Bessemer steel, which will stand a much greater strain than ordinary iron. They are milled inside, after the chase is welded, by a special milling machine, insuring accuracy not obtained by any other method. These chases are accurate and square, and are guaranteed against breaking or springing.

Bearer chases cost one-half more than regular chases.

Cast steel chases cost one-half more than our regular steel chases.

IMPORTANT.—In ordering chases mistakes will be avoided by observing the following instructions :

Give outside measurements.

Where chase or chases are to fit press, give actual size of bed. An allowance of 1/4 inch will be made in length of chases.

If chases are to be made from other than regular stock, state size desired.

If side sticks are ordered, state whether they are to be straight or beveled, and give length of forms if other than standard newspaper size.

NEWSPAPER CHASES—Folio.

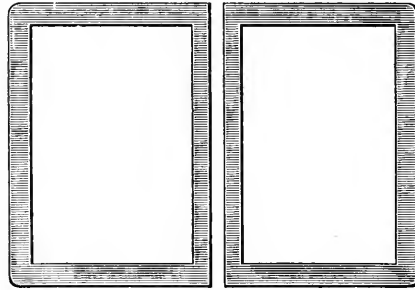

Twin or Folio Chases.

| Number. | Column Folio. | Size of Pair Over All. Inches. | Chase Size Each Outside Inches. | Measurement Length and Breadth Over All. Inches. | Size of Material.† | | | Price of Pair. |
|---------|---------------|---|---|--|--------------------------------|--------------------------------|--------------------------------|----------------|
| | | | | | Width of Side Bars. Inches. | Width of End Bars. Inches. | Width of Back Bars. Inches. | |
| 1 | *5 | 28 × 21 ³ / ₄ | 14 × 21 ³ / ₄ | 49 ³ / ₄ | 1 ¹ / ₁₆ | 1 ¹ / ₁₆ | 1 ³ / ₁₆ | \$ 9 50 |
| 2 | 5 | 29 ³ / ₈ × 22 ¹ / ₄ | 14 ¹¹ / ₁₆ × 22 ¹ / ₄ | 51 ⁵ / ₈ | 1 ¹ / ₁₆ | 1 ¹ / ₁₆ | 1 ³ / ₁₆ | 9 90 |
| 3 | *6 | 32 ¹ / ₂ × 24 | 16 ¹ / ₄ × 24 | 56 ¹ / ₂ | 1 ¹ / ₁₆ | 1 ¹ / ₁₆ | 1 ³ / ₁₆ | 10 85 |
| 4 | 6 | 33 ⁷ / ₈ × 24 | 16 ¹⁵ / ₁₆ × 24 | 57 ⁷ / ₈ | 1 ¹ / ₈ | 1 ¹ / ₈ | 1 ³ / ₁₆ | 11 00 |
| 5 | *7 | 38 × 25 ³ / ₄ | 19 × 25 ³ / ₄ | 63 ³ / ₄ | 1 ¹ / ₈ | 1 ¹ / ₈ | 1 ³ / ₁₆ | 12 15 |
| 6 | 7 | 38 ⁷ / ₈ × 26 | 19 ⁷ / ₁₆ × 26 | 64 ⁷ / ₈ | 1 ¹ / ₈ | 1 ¹ / ₈ | 1 ³ / ₁₆ | 12 35 |
| 7 | *7 × 6 | 41 × 27 | 20 ¹ / ₂ × 27 | 68 | 1 ¹ / ₈ | 1 ¹ / ₈ | 1 ³ / ₁₆ | 12 90 |
| 8 | *8 | 42 × 28 | 21 × 28 | 70 | 1 ¹ / ₄ | 1 ¹ / ₄ | 1 ⁵ / ₁₆ | 13 30 |
| 9 | 8 | 43 ⁵ / ₈ × 28 ¹ / ₄ | 21 ¹³ / ₁₆ × 28 ¹ / ₄ | 71 ⁷ / ₈ | 1 ¹ / ₄ | 1 ¹ / ₄ | 1 ⁵ / ₁₆ | 13 70 |
| 10 | *9 | 47 × 30 ¹ / ₂ | 23 ¹ / ₂ × 30 ¹ / ₂ | 77 ¹ / ₂ | 1 ¹ / ₄ | 1 ¹ / ₄ | 1 ⁵ / ₁₆ | 14 80 |
| 11 | 9 | 48 ³ / ₈ × 30 ¹ / ₄ | 24 ³ / ₁₆ × 30 ¹ / ₄ | 78 ⁵ / ₈ | 1 ¹ / ₄ | 1 ¹ / ₄ | 1 ⁵ / ₁₆ | 15 00 |
| 12 | Paper 24x36 | 40 × 26 ¹ / ₄ | 20 × 26 ¹ / ₄ | 66 ¹ / ₄ | 1 ¹ / ₈ | 1 ¹ / ₈ | 1 ³ / ₁₆ | 12 75 |

*These sizes are carried in stock, and will be furnished unless otherwise specified.

†Thickness of iron used in above chases is 5/8 inch.

To Estimate Price of Twin or Folio Chases, Sizes not Listed :

Add length and breadth of pair over all in inches and multiply by 19 cents per inch.

In figuring extra stock charges, consider each chase separately ; charges will be same as for Poster chase.

Minimum price per pair of Twin or Folio chases, \$9 00.

See Poster list for figuring measurements ending in fractions.

NEWSPAPER CHASES—Quarto.

| Size No. | Col. Quarto | Size of Pair Over All. Inches. | Size of Each Chase Outside. Inches. | Measurement Length and Breadth Over All. Inches. | Size of Material.† | | | | Price of Pair |
|----------|-------------|---|--|--|--------------------------------|--------------------------------|-------------------------------|------------------------------|---------------|
| | | | | | Width of Side Bars. Inches. | Width of End Bars. Inches. | Width of Back Bars. Inches. | Width of Cross Bars. Inches. | |
| 13 | *4 | 35 ⁷ / ₈ × 24 ¹ / ₄ | 17 ¹ / ₁₆ × 24 ¹ / ₄ | 60 ¹ / ₈ | 1 ¹ / ₁₆ | 1 ¹ / ₁₆ | ¹³ / ₁₆ | 1 | \$13 40 |
| 14 | 4 | 36 × 24 ¹ / ₂ | 18 × 24 ¹ / ₂ | 60 ¹ / ₂ | 1 ¹ / ₁₆ | 1 ¹ / ₁₆ | ¹³ / ₁₆ | 1 | 13 40 |
| 15 | *5 | 43 × 28 ¹ / ₂ | 21 ¹ / ₂ × 28 ¹ / ₂ | 71 ¹ / ₂ | 1 ¹ / ₈ | 1 ¹ / ₈ | ¹³ / ₁₆ | 1 | 15 85 |
| 16 | 5 | 44 ¹ / ₈ × 29 ¹ / ₂ | 22 ¹ / ₁₆ × 29 ¹ / ₂ | 73 ⁵ / ₈ | 1 ¹ / ₈ | 1 ¹ / ₈ | ¹³ / ₁₆ | 1 | 16 30 |
| 17 | *6 | 46 × 32 ¹ / ₂ | 23 × 32 ¹ / ₂ | 78 ¹ / ₂ | 1 ¹ / ₄ | 1 ¹ / ₄ | ¹³ / ₁₆ | 1 | 17 40 |
| 18 | *6 | 47 × 32 ¹ / ₂ | 23 ¹ / ₂ × 32 ¹ / ₂ | 79 ¹ / ₂ | 1 ¹ / ₄ | 1 ¹ / ₄ | ¹³ / ₁₆ | 1 | 17 60 |
| 19 | 6 | 47 ⁵ / ₈ × 34 | 23 ³ / ₁₆ × 34 | 81 ⁵ / ₈ | 1 ¹ / ₄ | 1 ¹ / ₄ | ¹³ / ₁₆ | 1 | 18 05 |
| 20 | *7 | 51 × 37 ¹ / ₂ | 25 ¹ / ₂ × 37 ¹ / ₂ | 88 ¹ / ₂ | 1 ⁵ / ₁₆ | 1 ⁵ / ₁₆ | ¹⁵ / ₁₆ | 1 | 19 60 |
| 21 | 7 | 52 ¹ / ₈ × 39 | 26 ¹ / ₁₆ × 39 | 91 ¹ / ₈ | 1 ⁵ / ₁₆ | 1 ⁵ / ₁₆ | ¹⁵ / ₁₆ | 1 | 20 25 |
| 22 | *8 | 56 ¹ / ₈ × 43 ¹ / ₂ | 28 ¹ / ₁₆ × 43 ¹ / ₂ | 99 ⁵ / ₈ | 1 ⁵ / ₁₆ | 1 ⁵ / ₁₆ | ¹⁵ / ₁₆ | 1 | 22 00 |

*These sizes are carried in stock, and will be furnished unless otherwise specified.

†Thickness of iron used in above chases is ⁵/₈ inch.

To Estimate Price per Pair of Quarto Chases, Sizes not Listed:

Add length and breadth of pair over all in inches and multiply by 22 cents per inch.

In figuring extra stock charges, consider each chase separately; charges will be the same as for Poster chase.

Minimum price for pair of Quarto chases, \$12 00.

See Poster list for figuring measurements ending in fractions.

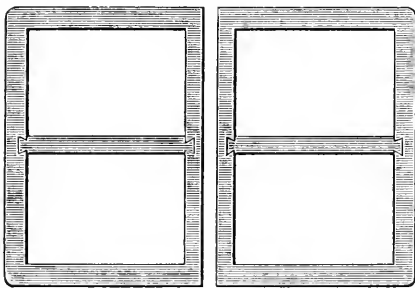

Twin or Quarto Chases with Bars.

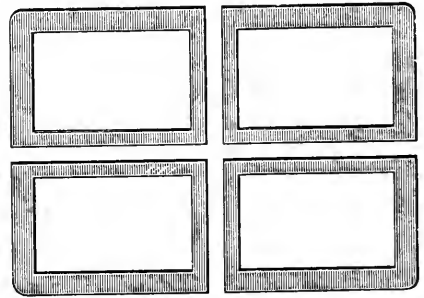

Quadruple Chases.

QUADRUPLE CHASES.

| Size No. | Column Quadruple. | Size of Pair Over All. Inches. | Size of Each Chase Outside. Inches. | Measurement Length and Breadth Over All. Inches. | Size of Material.† | | | | Price for Set of Four. |
|----------|-------------------|-------------------------------------|---|--|--------------------------------|-------------------------------|------------------------------------|-------------------------------|------------------------|
| | | | | | Width of Side Bars. Inches. | Width of End Bars. Inches. | Width of Outside End Bars. Inches. | Width of Back Bars. Inches. | |
| 23 | *5 | 28 × 42 ¹ / ₂ | 14 × 21 ¹ / ₄ | 70 ¹ / ₂ | 1 ¹ / ₁₆ | ¹³ / ₁₆ | 1 ¹ / ₁₆ | ¹³ / ₁₆ | \$19 90 |
| 24 | *6 | 32 ¹ / ₂ × 47 | 16 ¹ / ₄ × 23 ¹ / ₂ | 79 ¹ / ₂ | 1 ¹ / ₁₆ | ¹³ / ₁₆ | 1 ¹ / ₁₆ | ¹³ / ₁₆ | 22 40 |
| 25 | *7 | 38 × 50 ¹ / ₂ | 19 × 25 ¹ / ₄ | 88 ¹ / ₂ | 1 ¹ / ₈ | ¹³ / ₁₆ | 1 ¹ / ₈ | ¹³ / ₁₆ | 24 90 |

*These sizes are carried in stock, and will be furnished unless otherwise specified.

†Thickness of iron used in above chases is ⁵/₈ inch.

To Estimate Price of a Set of Quadruple Chases, Sizes not Listed:

Add length and breadth in inches of set over all and multiply by 28 cents per inch.

In figuring extra stock charges consider each chase separately; charges will be the same as for Poster chase.

Minimum price for set of Quadruple chases, \$18 00.

See Poster list for figuring measurements ending in fractions.

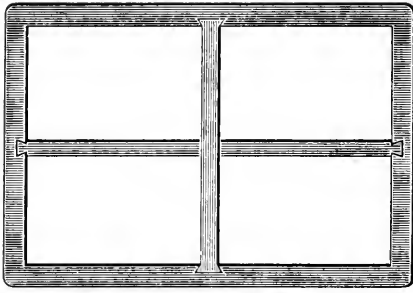

BOOK CHASES.

With Solid Cross Bar
and with
Both Bars Shifting.

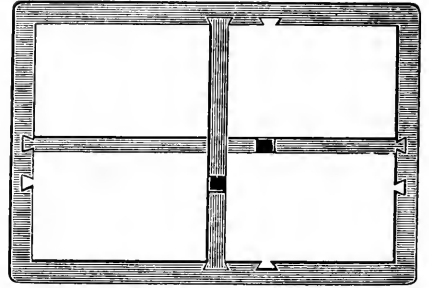

| Size No. | Outside Measurement. Inches. | | Measurement Length and Breadth. Inches. | Width of Iron.* | | Price of Chase with Solid Cross Bars. | Price of Chase One Bar Shifting. | Price of Chase Both Bars Shifting. |
|----------|------------------------------|-----|---|------------------|------------------|---------------------------------------|----------------------------------|------------------------------------|
| | | | | Side Bars. | End Bars. | | | |
| 26 | 17 | ×21 | 38 | 1 | 1 | \$ 8 50 | \$ 9 50 | \$10 50 |
| 27 | 20 | ×25 | 45 | 1 $\frac{1}{16}$ | 1 $\frac{1}{16}$ | 8 95 | 9 95 | 10 95 |
| 28 | 21 | ×27 | 48 | 1 $\frac{1}{16}$ | 1 $\frac{1}{16}$ | 9 30 | 10 30 | 11 30 |
| 29 | 22 | ×27 | 49 | 1 $\frac{1}{16}$ | 1 $\frac{1}{16}$ | 9 40 | 10 40 | 11 40 |
| 30 | 22 | ×28 | 50 | 1 $\frac{1}{16}$ | 1 $\frac{1}{16}$ | 9 50 | 10 50 | 11 50 |
| 31 | 23 | ×29 | 52 | 1 $\frac{1}{16}$ | 1 $\frac{1}{16}$ | 9 70 | 10 70 | 11 70 |
| 32 | 24 | ×30 | 54 | 1 $\frac{1}{16}$ | 1 $\frac{1}{16}$ | 9 95 | 10 95 | 11 95 |
| 33 | 25 | ×30 | 55 | 1 $\frac{1}{16}$ | 1 $\frac{1}{16}$ | 10 05 | 11 05 | 12 05 |
| 34 | 26 | ×32 | 58 | 1 $\frac{1}{16}$ | 1 $\frac{1}{16}$ | 10 40 | 11 40 | 12 40 |
| 35 | 26 | ×34 | 60 | 1 $\frac{1}{16}$ | 1 $\frac{1}{16}$ | 10 60 | 11 60 | 12 60 |
| 36 | 25 | ×35 | 60 | 1 $\frac{1}{16}$ | 1 $\frac{1}{16}$ | 10 60 | 11 60 | 12 60 |
| 37 | 26 | ×36 | 62 | 1 $\frac{3}{16}$ | 1 $\frac{3}{16}$ | 10 80 | 11 80 | 12 80 |
| 38 | 27 | ×39 | 66 | 1 $\frac{3}{16}$ | 1 $\frac{3}{16}$ | 11 25 | 12 25 | 13 25 |
| 39 | 29 | ×41 | 70 | 1 $\frac{3}{16}$ | 1 $\frac{3}{16}$ | 11 70 | 12 70 | 13 70 |
| 40 | 29 | ×42 | 71 | 1 $\frac{3}{16}$ | 1 $\frac{3}{16}$ | 11 80 | 12 80 | 13 80 |
| 41 | 30 | ×42 | 72 | 1 $\frac{3}{16}$ | 1 $\frac{3}{16}$ | 11 90 | 12 90 | 13 90 |
| 42 | 32 | ×44 | 76 | 1 $\frac{3}{16}$ | 1 $\frac{3}{16}$ | 12 35 | 13 35 | 14 35 |
| 43 | 32 | ×46 | 78 | 1 $\frac{3}{16}$ | 1 $\frac{3}{16}$ | 12 60 | 13 60 | 14 60 |
| 44 | 32 | ×47 | 79 | 1 $\frac{3}{16}$ | 1 $\frac{3}{16}$ | 12 70 | 13 70 | 14 70 |
| 45 | 33 $\frac{1}{2}$ | ×46 | 79 $\frac{1}{2}$ | 1 $\frac{3}{16}$ | 1 $\frac{3}{16}$ | 12 80 | 13 80 | 14 80 |
| 46 | 33 $\frac{1}{2}$ | ×48 | 81 $\frac{1}{2}$ | 1 $\frac{5}{16}$ | 1 $\frac{5}{16}$ | 13 00 | 14 00 | 15 00 |
| 47 | 34 | ×48 | 82 | 1 $\frac{5}{16}$ | 1 $\frac{5}{16}$ | 13 00 | 14 00 | 15 00 |
| 48 | 35 | ×50 | 85 | 1 $\frac{5}{16}$ | 1 $\frac{5}{16}$ | 13 35 | 14 35 | 15 35 |
| 49 | 36 | ×52 | 88 | 1 $\frac{5}{16}$ | 1 $\frac{5}{16}$ | 13 70 | 14 70 | 15 70 |
| 50 | 38 | ×51 | 89 | 1 $\frac{5}{16}$ | 1 $\frac{5}{16}$ | 13 80 | 14 80 | 15 80 |
| 51 | 37 $\frac{1}{2}$ | ×52 | 89 $\frac{1}{2}$ | 1 $\frac{5}{16}$ | 1 $\frac{5}{16}$ | 13 90 | 14 90 | 15 90 |
| 52 | 39 | ×53 | 92 | 1 $\frac{5}{16}$ | 1 $\frac{5}{16}$ | 14 10 | 15 10 | 16 10 |
| 53 | 41 | ×55 | 96 | 1 $\frac{5}{16}$ | 1 $\frac{5}{16}$ | 14 55 | 15 55 | 16 55 |
| 54 | 43 | ×56 | 99 | 1 $\frac{5}{16}$ | 1 $\frac{5}{16}$ | 14 90 | 15 90 | 16 90 |
| 55 | 40 | ×60 | 100 | 1 $\frac{5}{16}$ | 1 $\frac{5}{16}$ | 15 00 | 16 00 | 17 00 |
| 56 | 43 | ×60 | 103 | 1 $\frac{7}{16}$ | 1 $\frac{7}{16}$ | 15 35 | 16 35 | 17 35 |
| 57 | 43 | ×63 | 106 | 1 $\frac{7}{16}$ | 1 $\frac{7}{16}$ | 15 65 | 16 65 | 17 65 |
| 58 | 45 | ×62 | 107 | 1 $\frac{7}{16}$ | 1 $\frac{7}{16}$ | 15 75 | 16 75 | 17 75 |
| 59 | 45 | ×65 | 110 | 1 $\frac{7}{16}$ | 1 $\frac{7}{16}$ | 16 10 | 17 10 | 18 10 |
| 60 | 47 | ×66 | 113 | 1 $\frac{7}{16}$ | 1 $\frac{7}{16}$ | 16 45 | 17 45 | 18 45 |

*Width of long cross bars, $\frac{5}{8}$ inch. Width of short cross bars, 1 inch. Thickness of bars, $\frac{5}{8}$ inch.

To Estimate Price of Book Chase, Size not Listed:

Find price of same size Poster or Skeleton chase and add \$4 00 if solid bars only are wanted.

Add \$5 00 if one bar only is to be shifted, and \$6 00 if both bars are to be shifted.

Minimum price of Book chase, with both bars shifting, \$10 50.

For bar only, add \$1 00 to list; for pair of dovetails, add \$1 00 to list; for both, add \$2 00 to list.

For extra stock, charge same as in Poster chases.

See Poster list for figuring measurements ending in fractions.

POSTER CHASES.

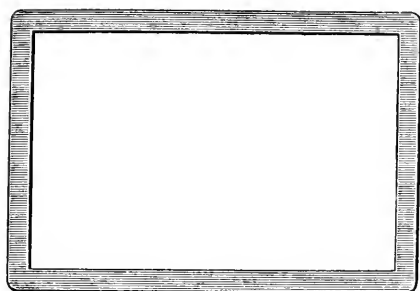

Without Bar.

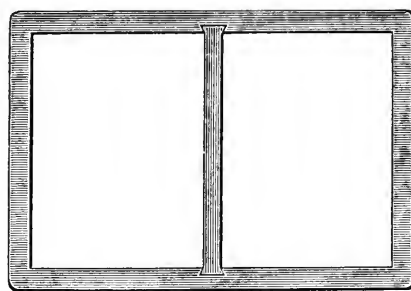

With Bar.

| Number. | Outside Measurement Inches. | Measurement Length and Breadth. Inches. | Size of Material.* | | | | Price of Poster Chase Without Bar. | Price of Poster Chase With Bar. Inches. |
|---------|-----------------------------|---|---------------------|----------------------|--------------------|----------------------|------------------------------------|---|
| | | | Width of Side Bars. | | Width of End Bars. | | | |
| | | | With Bar. Inches. | Without Bar. Inches. | With Bar. Inches. | Without Bar. Inches. | | |
| 61 | 17 × 21 | 38 | 1 | 1 1/16 | 1 | 1 1/16 | \$ 4 50 | \$ 6 50 |
| 62 | 20 × 25 | 45 | 1 1/16 | 1 1/8 | 1 1/16 | 1 1/8 | 4 95 | 6 95 |
| 63 | 21 × 27 | 48 | 1 1/16 | 1 1/8 | 1 1/16 | 1 1/8 | 5 30 | 7 30 |
| 64 | 22 × 28 | 50 | 1 1/16 | 1 1/8 | 1 1/16 | 1 1/8 | 5 50 | 7 50 |
| 65 | 24 × 30 | 54 | 1 1/16 | 1 1/8 | 1 1/16 | 1 1/8 | 5 95 | 7 95 |
| 66 | 26 × 32 | 58 | 1 1/16 | 1 1/8 | 1 1/16 | 1 1/8 | 6 40 | 8 40 |
| 67 | 25 × 35 | 60 | 1 1/16 | 1 1/8 | 1 1/16 | 1 1/8 | 6 60 | 8 60 |
| 68 | 27 × 39 | 66 | 1 3/16 | 1 1/4 | 1 3/16 | 1 1/4 | 7 25 | 9 25 |
| 69 | 29 × 42 | 71 | 1 3/16 | 1 1/4 | 1 3/16 | 1 1/4 | 7 80 | 9 80 |
| 70 | 32 × 46 | 78 | 1 3/16 | 1 1/4 | 1 3/16 | 1 1/4 | 8 60 | 10 60 |
| 71 | 32 × 47 | 79 | 1 3/16 | 1 1/4 | 1 3/16 | 1 1/4 | 8 70 | 10 70 |
| 72 | 33 1/2 × 48 | 81 1/2 | 1 3/16 | 1 3/8 | 1 3/16 | 1 3/8 | 9 00 | 11 00 |
| 73 | 34 × 50 | 84 | 1 5/16 | 1 3/8 | 1 5/16 | 1 3/8 | 9 25 | 11 25 |
| 74 | 35 × 52 | 87 | 1 5/16 | 1 3/8 | 1 5/16 | 1 3/8 | 9 55 | 11 55 |
| 75 | 37 × 54 | 91 | 1 5/16 | 1 3/8 | 1 5/16 | 1 3/8 | 10 00 | 12 00 |
| 76 | 39 × 53 | 92 | 1 5/16 | 1 3/8 | 1 5/16 | 1 3/8 | 10 10 | 12 10 |
| 77 | 39 × 55 | 94 | 1 5/16 | 1 3/8 | 1 5/16 | 1 3/8 | 10 35 | 12 35 |
| 78 | 41 × 55 | 96 | 1 5/16 | 1 3/8 | 1 5/16 | 1 3/8 | 10 55 | 12 55 |
| 79 | 43 × 60 | 103 | 1 7/16 | 1 1/2 | 1 7/16 | 1 1/2 | 11 35 | 13 35 |
| 80 | 47 × 66 | 113 | 1 7/16 | 1 1/2 | 1 7/16 | 1 1/2 | 12 45 | 14 45 |

*Width of cross bars, 1 inch. Thickness of bars, 5/8 inch.

To Estimate Price of a Poster Chase, Size not Listed :

Add length and breadth in inches together to obtain measure. Multiply this measure by 11 cents.

For price of News or Poster chase with bar, add \$2 00 to list of Poster without bar.

Minimum price of Poster chase, \$4 50.

For extra bar only, add \$1 00. For extra pair dovetails, add \$1 00.

Measurements ending in fractions to be figured as next full figure. For example: 17 × 20 3/4 in. = 37 3/4 in., figure 38 in.; 33 1/2 × 45 3/4 in. = 79 3/4 in., figure 80 in.; 29 3/8 × 40 1/2 in. = 69 7/8 in., figure 70 in.

CHARGES FOR EXTRA STOCK :

- For each 1/8 in. wider than regular, add for measurement (length and breadth) 40 ins. and smaller . \$0 40
- For each 1/8 in. wider than regular, add for measurement (length and breadth) 41 to 60 ins. incl. . . . 0 65
- For each 1/8 in. wider than regular, add for measurement (length and breadth) 61 to 80 ins. incl. . . . 0 90
- For each 1/8 in. wider than regular, add for measurement (length and breadth) 81 to 100 ins. incl. . . . 1 15
- For each 1/8 in. wider than regular, add for measurement (length and breadth) 101 and larger 1 40
- For 3/4 in. thick stock, add for measurement (length and breadth) 40 ins. and smaller 0 60
- For 3/4 in. thick stock, add for measurement (length and breadth) 41 to 60 ins. inclusive 1 00
- For 3/4 in. thick stock, add for measurement (length and breadth) 61 to 80 ins. inclusive 1 40
- For 3/4 in. thick stock, add for measurement (length and breadth) 81 to 100 ins. inclusive 1 80
- For 3/4 in. thick stock, add for measurement (length and breadth) 101 and larger 2 20
- For extra width and 3/4 inch thick stock, add both of the above advanced charges.

HEADING CHASES.

Estimate Price of Heading Chase, Size not Listed, Same as Poster Chase :



Minimum price of Heading chase without bar, \$4 50.
 For bar and pair of dovetails, add \$2 00.
 Unless otherwise ordered, cross-bar Heading chases will be furnished.
 Figure extra stock same as in Poster chases.
 See Poster list for figuring measurements ending in fractions.

| Number. | Size of Chase Outside With Bar. Inches. | Size of Chase Inside. Inches. | Measure-ment Length and Breadth. Inches. | Size of Material. | | | | Price of Chase Without Bar. | Price of Chase With Bar. |
|---------|---|-------------------------------|--|---------------------|----------------------|--------------------|----------------------|-----------------------------|--------------------------|
| | | | | Width of Side Bars. | | Width of End Bars. | | | |
| | | | | With Bar. Inches. | Without Bar. Inches. | With Bar. Inches. | Without Bar. Inches. | | |
| 81 | 8 × 19 | 6 × 17 | 27 | 1 | 1 1/16 | 1 | 1 1/16 | \$4 50 | \$6 50 |
| 82 | 10 × 23 | 8 × 21 | 33 | 1 | 1 1/16 | 1 | 1 1/16 | 4 50 | 6 50 |
| 83 | 10 1/8 × 30 1/8 | 8 × 28 | 40 1/4 | 1 1/16 | 1 1/8 | 1 1/16 | 1 1/8 | 4 50 | 6 50 |

Width of cross bars, 1 inch. Thickness of bars, 5/8 inch.

ELECTROTYPE CHASES.

| Size Number. | Outside Measurement. Inches. | Inside Measurement. Inches. | Price of Chase. |
|--------------|------------------------------|-----------------------------|-----------------|
| 84 | 13 × 17 | 10 × 14 | \$5 70 |
| 85 | 15 × 21 | 12 × 18 | 5 70 |

Width of side and end bars, 1 1/2 inches. Thickness of bars, 5/8 inch.

Compute cost of Electrotpe chases same as for Poster, adding for extra stock.
 Minimum price, \$5 70.
 See Poster list for figuring measurements ending in fractions.

CAST IRON CHASES.

These are Finished Inside.

| Outside Measure. | Price, each. | Outside Measure. | Price, each. | Outside Measure. | Price, each. |
|------------------|--------------|------------------|--------------|-------------------------|--------------|
| 6 × 7 | \$0 45 | 10 × 24 | \$1 50 | 12 × 33 | \$2 25 |
| 6 1/2 × 8 1/4 | 0 50 | 10 × 25 1/2 | 1 65 | 13 3/4 × 20 1/2 | 1 75 |
| 6 × 18 | 1 20 | 10 × 28 | 1 75 | 14 × 16 | 1 40 |
| 8 × 10 | 0 80 | 11 × 16 | 1 30 | 14 × 18 | 1 75 |
| 9 × 12 | 1 00 | 10 1/2 × 14 1/2 | 1 25 | 14 3/4 × 19 1/4 | 1 80 |
| 8 1/2 × 14 | 1 10 | 12 × 14 | 1 20 | 15 × 24 | 2 00 |
| 8 × 20 | 1 30 | 12 × 15 | 1 30 | 16 × 19 | 1 90 |
| 8 × 24 | 1 40 | 12 × 18 | 1 40 | 17 × 22 | 1 75 |
| 8 × 28 | 1 60 | 12 × 26 | 1 80 | 17 × 22, with cross bar | 2 25 |
| 10 × 14 | 1 20 | 12 × 30 | 1 90 | | |

IRON SIDE AND FOOT STICKS.



Straight, 5/8 × 5/8, per inch \$0 04
 Beveled, 5/8 to 1 inch × 5/8, per inch 0 05

Side sticks are made, unless otherwise ordered, 1/4 inch longer than the standard length of form, and foot sticks are made 1/4 inch shorter than standard width of form. If larger than 6-Point column rules are used, or columns wider than 13 ems Pica, allowance will have to be made.

WROUGHT IRON CHASES FOR JOB PRESSES.

To insure a perfect fit on bed of press, we recommend customers to send sample chase with order after ascertaining that sample chase fits correctly.

| | |
|--|--------|
| For 7 × 11, 8 × 12 and 9 × 13 presses | \$5 00 |
| For 10 × 15 and 11 × 17 presses | 5 50 |
| For 12 × 18 and 13 × 19 presses | 6 50 |
| For 14 × 20, 14 × 22, and 14½ × 22 presses . . . | 7 25 |
| Minimum price of job press chase | 5 00 |

CHASES FOR C. & P. GORDON PRESSES.

| Inside Measure. | Cast Iron. | Cast Iron Screw. | Steel. | Steel Screw. |
|--|------------|------------------|--------|--------------|
| 7 × 11 in. | \$1 00 | \$1 50 | \$2 70 | \$4 00 |
| 8 × 12 in. | 1 25 | 1 90 | 3 00 | 4 50 |
| 10 × 15 in. | 1 50 | 2 25 | 4 50 | 6 75 |
| 12 × 18 in. | 2 00 | 3 00 | 5 25 | 8 00 |
| 14 × 10 in. | 2 50 | 3 75 | 5 75 | 8 50 |
| 14½ × 22 in. | 3 00 | 4 50 | 6 00 | 9 00 |
| 13 × 19 in., special for 12 × 18 press | | | 6 00 | |

CHASES FOR GALLY UNIVERSAL PRESSES.

| | For 10x15 Press. | For 13x19 Press. | For 14x22 Press. |
|---------------------------|------------------|------------------|------------------|
| Cast iron | \$2 00 | \$2 25 | \$2 75 |
| Wrought iron | 5 50 | 6 50 | 7 25 |
| *Steel skeleton | 5 50 | 6 50 | 7 25 |

* Steel skeleton chases give more lock-up room, but do not add to printing capacity of press.

CHASES FOR PEERLESS PRESSES

| | Cast Iron. | Steel. |
|------------------------------|------------|--------|
| For 8 × 12 press | \$1 25 | \$3 00 |
| For 9 × 13 press | 1 50 | 3 50 |
| For 10 × 15 press | 1 50 | 4 50 |
| For 11 × 17 press | 2 00 | 5 00 |
| For 14 × 20 press | 2 50 | 5 75 |
| For 14½ × 22 press | 3 00 | 6 00 |

CHASES FOR JOB PRESSES.

Chases for job presses not shown in this catalogue can only be obtained by sending to the factory. Always send name of press and manufacturer's number, and specify whether chase is to be sent direct from the factory by express or freight. We can make new chases using old ones as a pattern at an advance over the prices for Chandler & Price Gordon Chases.

SPIDER CHASES FOR C. & P. JOB PRESSES.

These chases are invaluable for locking up small forms. They require but little furniture, and forms do not spring as is the case when locked up in a large chase.

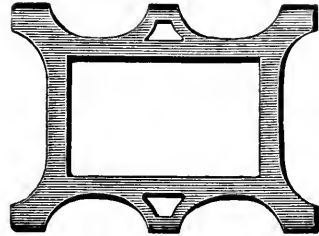

| Inside Chase. | Price. |
|---|--------|
| 4 × 6 inches, for 7 × 11 press | \$1 00 |
| 4 × 6 inches, for 8 × 12 press | 1 25 |
| 5 × 8 inches, for 10 × 15 press | 1 50 |
| 6 × 9 inches, for 12 × 18 press | 2 00 |
| 7 × 11 inches, for 14 × 20 press | 2 50 |
| 8 × 12 inches, for 14½ × 22 press | 3 00 |

STEREOTYPE CHASES.

The Best Made.

These stereotype chases are made in the most accurate manner, exactly type high, perfectly square and true. The side lock-up screw is attached to the side stick with a collar in such a manner as to enable the operator to lock up and unlock the chases with the wrench, drawing the side stick back and forward instantly, thus saving much time and avoiding the use of shooting stick and mallet, and consequent injury to the side stick. Prices, according to size, furnished on application.

Lock-up wrenches for stereotype chases, price \$2 50

FORM TRUCK.

Both the Form Trucks listed below are of malleable iron. The Union Form Truck is painted red.

The use of a form truck should be insisted on in every press room of any size, not only because it is a time saver, but because sliding chases along the floor is a source of frequent accidents.

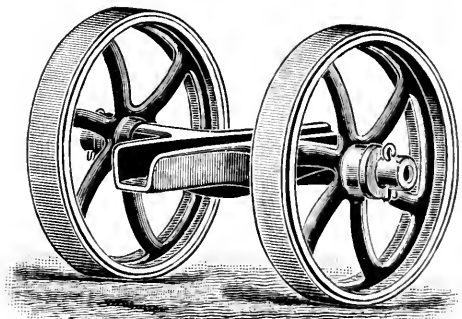

| | |
|--|--------|
| Iron tire | \$3 00 |
| Union Form Truck, with rubber tire | 5 00 |

HAND ROLLERS.

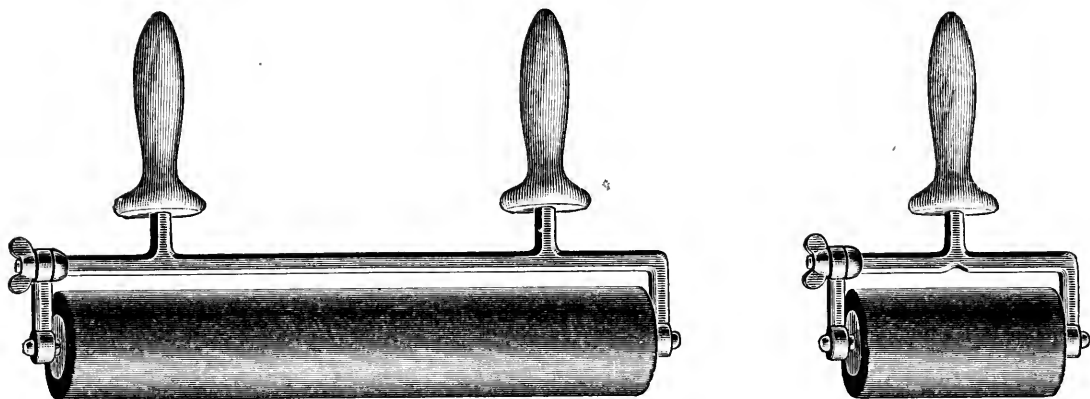

When complete rollers are ordered, we furnish them cast three inches in diameter with the best roller composition. There is no economy in cheap roller composition.

| Number of Handles. | Frame and Handle. | Roller Complete. | Extra Stock. | Number of Handles. | Frame and Handle. | Roller Complete. | Extra Stock. |
|--------------------|-------------------|------------------|--------------|--------------------|-------------------|------------------|--------------|
| 6 in. . . 1 . . . | \$1 25 | \$1 85 | \$0 40 | 24 in. . . 2 . . . | \$3 25 | \$5 65 | \$1 00 |
| 8 in. . . 1 . . . | 1 50 | 2 30 | 0 40 | 26 in. . . 1 . . . | 3 75 | 6 35 | 1 15 |
| 10 in. . . 1 . . . | 1 75 | 2 75 | 0 60 | 30 in. . . 1 . . . | 4 50 | 7 50 | 1 25 |
| 12 in. . . 1 . . . | 2 00 | 3 20 | 0 60 | 36 in. . . 1 . . . | 5 00 | 8 60 | 1 40 |
| 14 in. . . 2 . . . | 2 25 | 3 65 | 0 70 | 40 in. . . 1 . . . | 5 50 | 9 50 | 1 50 |
| 16 in. . . 2 . . . | 2 50 | 4 10 | 0 70 | 44 in. . . 1 . . . | 6 00 | 10 40 | 1 60 |
| 18 in. . . 2 . . . | 2 75 | 4 55 | 0 80 | 50 in. . . 1 . . . | 6 50 | 11 50 | . . |
| 20 in. . . 2 . . . | 3 00 | 5 00 | 0 80 | 54 in. . . 1 . . . | 7 00 | 12 40 | . . |

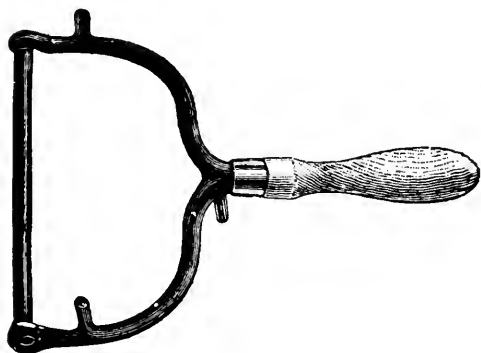

BRAYERS.

Malleable iron frame, wooden core and handle.

| | Frame and Core. | Roller Complete. |
|------------------|-----------------|------------------|
| 6-inch | \$0 90 | \$1 20 |
| 8-inch | 1 00 | 1 40 |

PRICES FOR CASTING ROLLERS.

Rollers for Job Presses.

| | Size Press. | Each. |
|----------------------------|--------------------|-------|
| Eighth Medium | 7 × 11 | \$ 40 |
| Eighth Medium | 8 × 12 | 40 |
| Eighth Medium | 9 × 13 | 45 |
| Quarto Medium | 10 × 15 | 80 |
| Quarto Medium | 11 × 17 | 1 00 |
| Quarto Medium | 12 × 18 | 1 00 |
| Half Medium | 13 × 19 | 1 00 |
| Half Medium | 14 × 20 | 1 10 |
| Half Super-Royal | 14½ × 22 | 1 25 |

Rollers for Hand and Cylinder Presses.

| | |
|---|--------|
| Cylinder Press Rollers, Bingham's Composition, per pound | \$0 35 |
| Hand Press Rollers, 3 inches in diameter, per running inch | 0 10 |
| Hand Press Rollers, larger than 3 inches in diameter, per pound | 0 35 |

ROLLER COMPOSITION.

We recommend the use of the best compositions only.

| | |
|-------------------------------------|--------|
| Bingham's Standard, per lb. | \$0 35 |
| Bingham's Durable, per lb. | 0 50 |
| Gem, for Northwest, per lb. | 0 40 |

ROLLER COMPOSITION KETTLE.

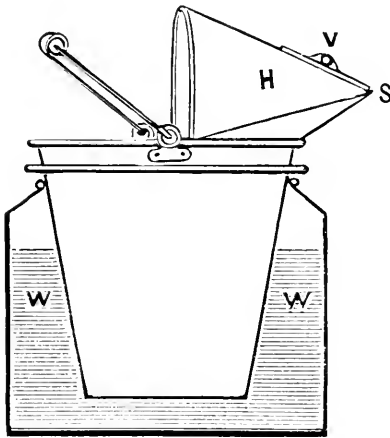

Consists of two separate kettles—the inner one to hold the composition, the outer to hold water, which prevents the composition from burning. A large and capacious hood (H) covers half the kettle, as in the cut. In the upper piece of this hood, at the front edge (at S), there is a semicircular aperture, about three-fourths of an inch wide and five-eighths high. This pouring-hole can be wholly or partly closed by a slide (V) of tin sliding in tin grooves. This slide has a ring (V) for the finger, soldered upon its upper surface, by which it is opened or closed. The under edge of the slide has an elliptical scollop in it, so as to give a good shape to the stream when small rollers are cast, when only a small stream should be used. The hood should be high and capacious.

| | |
|--|---------|
| 25-pound kettle, with outer kettle | \$ 7 50 |
| 50-pound kettle, with outer kettle | 11 50 |

STEEL ROLLER SUPPORTERS.

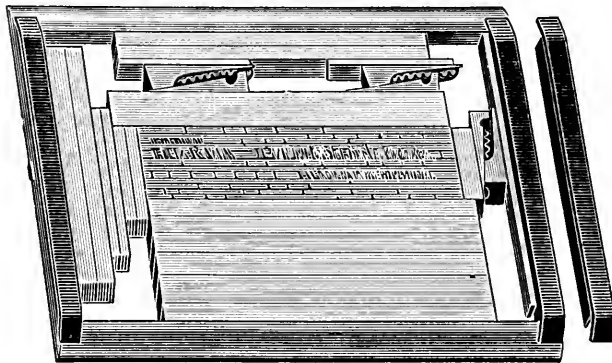

The best bearers yet devised for job presses. They only take up a quarter of an inch of the inside space of a chase, ease the pressure of the rollers on the form, prevent over-inking, equalize the impression, and save the rollers from cutting, as they are 3/8-inch wide on top.

| | Per pair. | | Per pair. |
|---------------------------|-----------|----------------------------|-----------|
| For 5×9 chase | \$0 35 | For 11 ×17 chase | 0 60 |
| For 7×11 chase | 0 40 | For 13 ×19 chase | 0 75 |
| For 8×12 chase | 0 45 | For 14 ×20 chase | 0 90 |
| For 10×15 chase | 0 50 | For 14½×22 chase | 0 90 |

UNION TABLETING APPARATUS.

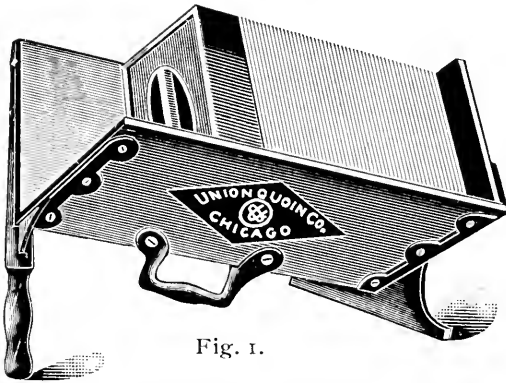

Fig. 1.

In this apparatus paper is held for padding without the use of screws or clamps. The trough (Fig. 1) is V-shaped, and is held at an angle which holds the paper snugly against the sides and the iron base-plate, which forms the bottom of the trough when it is tilted up. The paper in the trough is held under pressure by a heavy iron weight or brick; the trough is tilted up, and is lifted away, leaving the iron base-plate, paper and iron brick as in Fig. 2. The advantage this method has over the

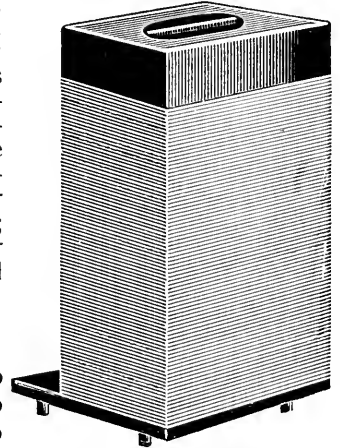
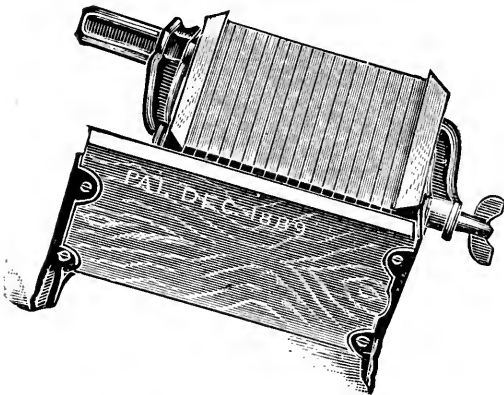

Fig. 2.

tablet presses using clamps is that, by buying extra base-plates and iron bricks, an unlimited number of piles of paper may be put up without waiting for the drying of the cement; thus the capacity of this apparatus surpasses that of other apparatus used for a like purpose, and is equally as well adapted for use in both large and small establishments.

- Complete, with trough, base-plate and hollow iron brick,
size 8½×8½×18 inches; capacity, 6000 sheets . . . \$7 50
- Extra iron bricks, hollow, each 2 00
- Extra iron bricks, solid, each 3 00
- Extra iron base-plates, each 0 75

COTT'S IMPROVED TABLET HOLDER AND CLAMP,



for straightening up and clamping sheets of paper while being glued for tablets. Will hold any quantity up to 3000 sheets of paper, and any size from 2½×2½ to 8½×14 inches.

With an additional clamp and larger press boards almost any size of work can easily be handled.

Accommodates all sizes of commercial stationery and admits of their being glued on one or both sides.

Offices doing a good-sized business should always order one or more extra clamps and sets of boards.

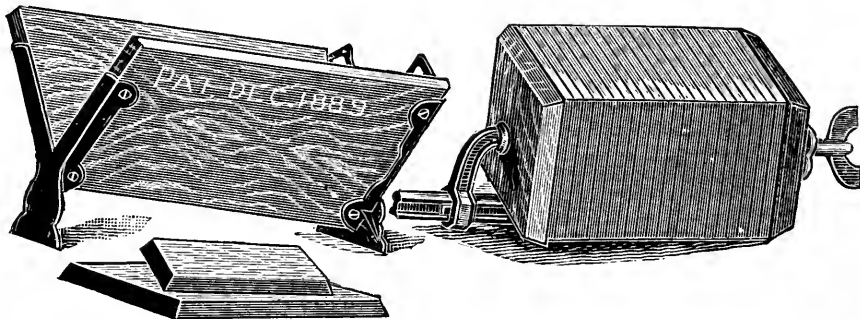

- Tablet holder and clamp, with set of four press boards \$3 25
- Extra clamp and four press boards 1 60
- Extra clamp without press boards 1 25

BINGHAM & RUNGE LIQUID PADDING GLUE.

Made in Red, Purple, Green and Colorless.

The Bingham & Runge Padding Glue was the first put on the market, and it has always maintained its reputation. The best materials are used in its composition, and on this account it does not get rancid. A quart will cement about 100,000 sheets of note size.

| | | | |
|----------------------|--------|-------------------|--------|
| Half-Pints | \$0 35 | Quarts | \$1 00 |
| Pints | 0 60 | Gallons | 3 75 |

LIQUID CEMENT BRUSH.

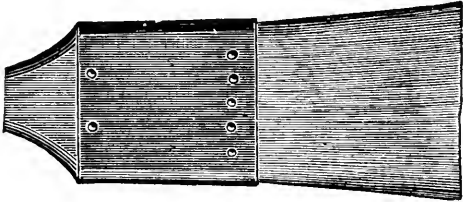

Made of French bristles, flat and double thick.

| | | | |
|----------------------|--------|----------------------|--------|
| 1 inch | \$0 30 | 2 inch | \$0 55 |
| 1 1/2 inch | 0 40 | 3 1/2 inch | 0 75 |



BINGHAM & RUNGE HERCULES ELASTIC PADDING GLUE.

An elastic, tough, quick-drying preparation, which is applied hot after melting in an ordinary glue pot, and, while entailing more labor, gives better results than the liquid glue. Does not adhere to the edges of sheets as they are removed from the pad, thus preventing tearing of pages in invoice and letter copying books. The color is bright red. Put up in pails, with directions for use on each.

5 pounds in pails . . \$1 50 | 10 pounds in pails . . \$3 00



PAPER COUNTER.

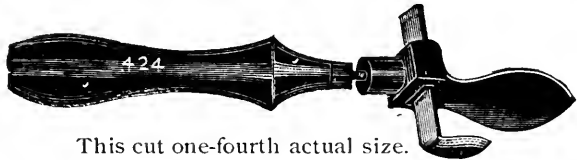

This cut one-fourth actual size.

To make ready for use in pad work, count out number of sheets wanted by hand, on top of which place the plate, then draw the stab up firmly against the paper. The screw in handle holds the stab in place. To operate, place plate on top of lot to be counted and push stab into paper, bearing down at same time.

Price \$0 75

GLUE POT.

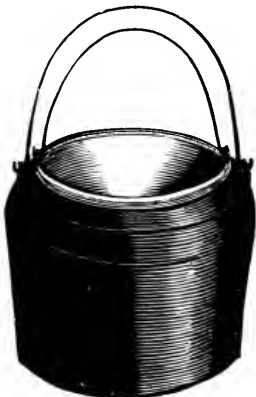

1 quart, each \$0 90
2 quarts, each 1 20

TABLET KNIFE.



Made specially for separating pads; extra thin and strong.

Price \$0 50

HERCULES LIQUID OVERLAY.

A substitute for paper overlays, giving a finer, quicker make-ready, and saving lots of time and tedious work. It is put on thinly with a camel's-hair brush, and the first application should be allowed to dry before putting on another, if the first is not heavy enough. It dries very quickly. If the Liquid Overlay is put on too thickly, the overlay is reduced by scraping it with fine emery cloth.

Each pressman should have an independent supply in a small phial suitable for carrying in the vest pocket.

4-ounce bottle, net \$1 25
 8-ounce bottle, net 2 00

Full directions with each bottle.

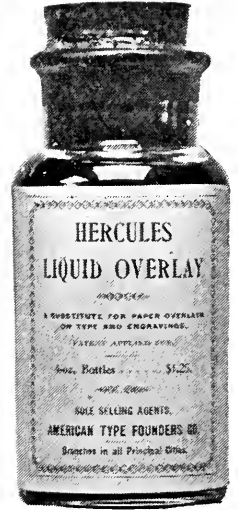

“BENTROVATO.”

[TRADE MARK.]

Dispels Electricity from Paper on Printing Presses.

A chemical fluid preparation which, applied in a small quantity to the tympan sheet by means of a sponge, cloth or cotton waste, effectually dispels the electricity generated in cylinder presses—a difficulty which results in serious losses to printers.

In all offices where there is a tendency toward this trouble, a bottle of “Bentrovato” will prove as valuable as the proverbial “stitch in time.”

“Bentrovato” is used in a majority of the larger printing offices throughout the United States.

American Type Founders' Co.: Please send me at once by American Express one bottle of “Bentrovato.” I should not like to be without it, even if it cost \$10 per bottle. Our devil knocked over the first bottle you sent us. I bought it with no faith, simply because I was willing to try anything. Our paper was as if possessed by ten thousand devils. The trouble ended at once and completely with the use of the “Bentrovato.”—*WALTER B. SHEPPARD, publisher of the Pan Yan Democrat (founded in 1818).*

Per bottle, net \$0 50

INKOLEUM.

A liquid preparation of world-wide fame for reducing and refining printing inks without impairing the color. It makes intractable inks work smoothly on discs, cylinders and rollers, and, mixed with caked inks, makes them useful again. Handy to have in the press room, as it is invaluable in cases of emergency.



Per bottle, half pound \$0 50

CHESAPEAKE ECONOMY COMPOUND.

The Effective Ink Reducer for both Lithographic and Letter-press Inks.

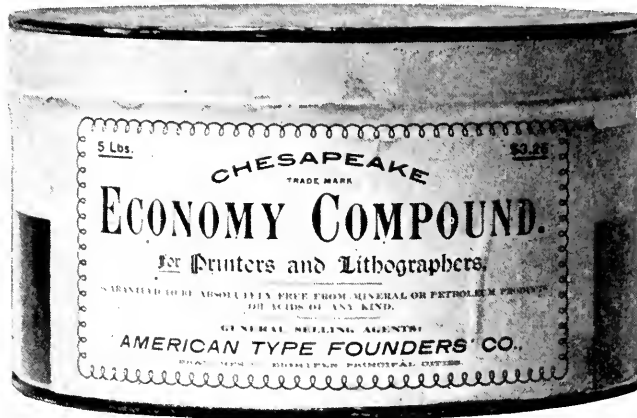

IT IS PURE.—Chesapeake Economy Compound is absolutely free from mineral petroleum products or acids of any kind, and is perfectly safe. Varnishes may be added, if required.

IT HELPS INKS.—Any kind or color of ink mixed with Chesapeake Economy Compound will not dry on forms or rollers, and will not skin when exposed to the air. Upon being mixed with ink, Economy Compound becomes thoroughly identified with it, and with less weight of ink a solid, sharp print is obtained. Inks mixed with Economy Compound will cover 30 per cent. more paper than if used without it.

IT PREVENTS TROUBLE.—Coated and surface papers will not pull if printed with ink mixed with Economy Compound, and the use of the Compound tends to prevent off-set and to make inks dry quicker on paper. It is not necessary, as a rule, to wash up rollers at night when inks are mixed with Economy Compound, as the inks will not dry on rollers. Economy Compound keeps lithographic stones in good condition, and inks mixed with it lift well from the stone.

| | |
|-------------------------|--------|
| 1-pound cans | \$0 75 |
| 5-pound cans | 3 25 |
| 10-pound cans | 6 00 |
| 25-pound cans | 13 75 |
| 50-pound cans | 25 00 |

EUREKA TYPE WASH.



The most effective powder preparation for removing ink from type rollers and plates. Does not injure brushes, corrode type, nor hurt the hands. Directions on every package. While its action is gentle, it is quite as effective for cleaning as the most powerful lye. One pound of powder will make eight gallons of washing fluid.

| | |
|-------------------------------|--------|
| 1-pound cans, each | \$0 20 |
| 5-pound cans, each | 0 75 |
| 10-pound cans, each | 1 25 |
| 50-pound tubs, each | 5 00 |

BURBANK'S EMBOSSING COMPOSITION.

This is an approved and satisfactory liquid chemical preparation for making counter dies for embossing, which, after exposure for a few minutes to light and air, hardens into a stone-like substance, making a perfect counterpart.

It is easily applied, according to directions printed on every can, and greatly simplifies and cheapens the process of embossing.

Price, net \$0 75



**BURBANK'S
"PRACTICAL GUIDE TO
EMBOSSING."**

This book explains lucidly and gives directions for several processes of embossing. It is the standard work on the subject.

Price, net \$1 00

WHITESON'S EMBOSSING COMPOSITION.



Shows exact size of cake.

This differs materially from other substances used for the same purpose, having among its ingredients certain chemicals which are affected only by heat. It can be readily softened by immersing in hot water. Will harden in three to five minutes, giving ample time to take impression and trim up die. Composition is of stone-like hardness, but not brittle, forming a most effective medium for forcing the paper or cardboard into the interstices of the die. *It can be remelted and used any number of times.*

- No. 1. For light work, per cake \$1 00
- No. 2. For heavy work, per cake 1 00

BRONZING MITTEN.

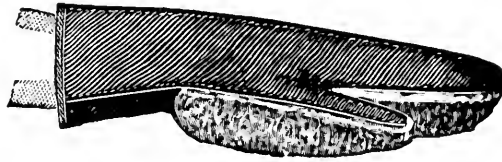

A convenient appliance for bronzing. Made from sheep's wool, with strong cloth back, and is impervious to bronze.

Each \$0 50

ELM CITY BRONZING PAD.



This has become an article of necessity in the press room. Saves time and bronze, and insures clean work.

Large, 2½×6 inches \$2 50
 Small, for light work, 2½ inches square 1 50

ADAMSON DISK COVER.

We have sold some hundreds of these useful Disk Covers, and none have been returned. Recommended as savers of ink and time, and approved by all purchasers.

Makes Copying Inks Work Easy.

Cold iron and copying inks repel each other. To avoid trouble, slip an Adamson Disk Cover over your disk. It is made of special cloth, lined with rubber. Iron dries the ink, deadens it, wastes it. The cloth disk gives good distribution, becomes saturated with ink like a stamp pad, and saves 50 per cent. of ink. When job is done, lift off disk cover. Saves washing time, and all the ink in cover is available the next time you use it. In ordering send the exact size of ink disk.

Due Owing to the limited space between edge of disk and chase-latch, these disks cannot be used on Golding Jobber and Pearl Presses.

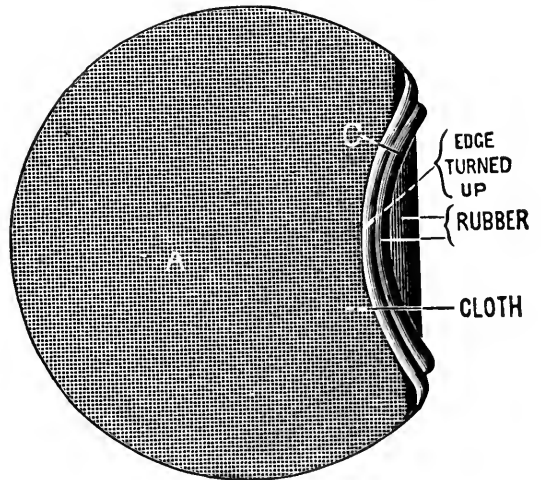

| | | | |
|---------------------------------------|--------|--|--------|
| For press 7×11 inches, net | \$1 50 | For press 13 ×19 inches, net | \$2 50 |
| For press 8×12 inches, net | 1 50 | For press 14 ×20 inches, net | 3 00 |
| For press 9×13 inches, net | 1 50 | For press 14½×22 inches, net | 3 00 |
| For press 10×15 inches, net | 2 00 | | |
| For press 11×17 inches, net | 2 00 | | |
| For press 12×18 inches, net | 2 50 | | |

Send exact size of disk when ordering. Directions with each Disk Cover.

PRINTING INKS.

These Inks are made by one of the most extensive Ink manufacturers in the world, and have a world-wide reputation for quality and uniformity. We use them exclusively on our own specimen printing. Inks for special work and to match all colors furnished to order expeditiously.

SMALLEST PACKAGES SOLD.

News Ink in packages as per Price List below.

| | |
|--|--|
| 2 lb.—Inks listed at 25 cents per lb. | ½ lb.—Inks listed at 75 cents per lb. |
| 1 lb.—Inks listed at 50 cents per lb. | ¼ lb.—Inks listed at \$1 50 per lb. and over. |

N. B.—All Inks listed at \$1.50 and over supplied in ¼-lb. tubes if so ordered, but at a lesser discount than is allowed on Inks sold in cans.

SUPERIOR NEWS INKS.

| | 5 and 10 lb. cans. | 28 and 56 lb. cans. | 112 lb. barrels. | 224 lb. barrels. | 450 lb. barrels |
|-------------------------------------|-----------------------|------------------------|---------------------|---------------------|--------------------|
| For hand presses, per lb. | \$0 20 | \$0 15 | | | |
| For flat-bed presses, " | 0 18 | 0 14 | \$0 13 | \$0 12 | \$0 12 |
| For perfecting presses, " | | | 0 13 | 0 12 | 0 12 |

BLACK INKS.

| | Per lb. | | Per lb. |
|---|---------|--|---------|
| Engraver's Wood-cut Proof Black | \$8 00 | Union Black, I, job | \$1 50 |
| Extra Fine Union Black, E, for half-tones | 5 00 | Insurance Policy Black | 1 00 |
| Extra Fine Union Black, E, cut and job | 5 00 | Columbian Black, H, for half-tones | 1 00 |
| Fine Union Black, F, for half-tones | 3 00 | Fine Book and Job, K | 1 00 |
| Fine Union Black, F, cut and job | 3 00 | Brilliant Black, L, job | 0 75 |
| Gloss Black | 2 00 | Brilliant Black, L, book | 0 75 |
| Fine Cut, G, for half-tones | 2 00 | Job Ink, M | 0 50 |
| Fine Job and Cut, G | 2 00 | Book Ink, M | 0 50 |
| Union Black, I, for half-tones | 1 50 | Book, Special | 0 35 |
| | | Book Ink, N | 0 25 |

SPECIAL BLACK INKS.

| | |
|--|--------|
| Fast Lustra Black, for printing line and half-tone cuts, with type, on ordinary news paper on the fastest web presses (smallest quantity sold, 28 lbs.) | \$0 50 |
| Lustra Black, for printing half-tones, with type and line cuts, on cheap papers on perfecting presses, speed about 5000 per hour (smallest quantity sold, 28 lbs.) | 0 45 |
| Niagara Black, for printing half-tones, with type and line cuts, on cheap papers on flat-bed presses (smallest quantity sold, 10 lbs.) | 0 40 |

BLUE= AND GREEN=BLACK INKS.

| | | | |
|-------------------------------------|--------|----------------------------|--------|
| Bronze Blue-Black, light | \$2 50 | Blue-Black, dark | \$1 50 |
| Bronze Blue-Black, medium | 2 00 | Fine Green-Black | 2 00 |

SPECIAL FAST-PRESS COLORS.

These are for use on colored supplements of newspapers printed on the fastest web presses. Smallest quantity sold, 28 lbs.

| | | | |
|---------------------------|--------|-----------------------------|--------|
| Fast-press Red | \$1 25 | Fast-press Green | \$1 00 |
| Fast-press Blue | 1 00 | Fast-press Yellow | 0 85 |

BROWN INKS.

| | | | | | |
|------------------------------|--------|---------------------------|--------|-------------------------------|--------|
| Brown Lake | \$4 00 | Gloss Brown | \$3 00 | Ochre | \$1 00 |
| Photographic Brown | 3 00 | Velvet Brown | 2 50 | Poster Brown, dark | 0 50 |
| Virginia Brown | 3 00 | Terra di Sienna | 2 00 | Poster Brown, light | 0 50 |
| Bismarck Brown | 3 00 | Mahogany Brown | 2 00 | | |

RED INKS.

| | Per lb. | | Per lb. | | Per lb. |
|--------------------------|---------|-------------------------------|---------|-----------------------------|---------|
| Madder Lake | \$10 00 | Claret Color | \$5 00 | Brilliant Red, me- | |
| Geranium Carmine, | | Nassau Lake | 4 50 | dium, Lake shade . | \$2 00 |
| oo | 10 00 | Scarlet Lake | 4 00 | Brilliant Red, light . | 1 00 |
| Geranium Carmine, | | Rose Lake, dark | 4 00 | Paris Lake | 2 50 |
| I. | 8 00 | Rose Lake, medium | 3 00 | Hamburg Red | 2 50 |
| Geranium Lake, | | Rose Lake, light | 3 00 | Label Red | 2 00 |
| dark | 5 00 | Deep Cherry | 4 00 | Chinese Vermilion | 2 00 |
| Geranium Lake, | | Crimson Lake | 4 00 | Brilliant Lake, B | 1 50 |
| medium | 5 00 | Carmine Vermilion | 4 00 | Brilliant Lake, G | 1 50 |
| Geranium Lake, | | Gloss Red | 3 00 | Deep Red | 1 50 |
| light | 5 00 | Antique Red (for old- | | Granat Vermilion | 1 00 |
| Bronze Carmine | 5 00 | style red and black | | Poster Red | 0 50 |
| Bronze Red | 4 00 | effects) | 3 00 | Poster Orange | 0 50 |
| Levantine Red. | 5 00 | Brilliant Red, dark | 3 00 | | |

BLUE INKS.

| | | | | | |
|------------------------------|--------|----------------------------------|--------|-------------------------|--------|
| Blue Lake, dark | \$5 00 | Imperial Blue | \$3 00 | Brussels Blue | \$2 50 |
| Blue Lake, light | 5 00 | Gloss Blue | 3 00 | Oriental Blue | 2 50 |
| Peacock Blue | 4 00 | Bronze Blue, No. 1 | 2 50 | Marine Blue | 2 00 |
| Milori Blue | 3 00 | Bronze Blue, No. 2 | 2 50 | Label Blue | 2 00 |
| Ultramarine, dark | 3 00 | Deep Br'ze Blue, No. 1 | 2 50 | Deep Blue | 1 50 |
| Ultramarine, light | 1 50 | Prussian Blue | 2 50 | Poster Blue | 0 50 |

GREEN INKS.

| | | | | | |
|----------------------------------|--------|------------------------------|--------|-------------------------------|--------|
| Brilliant Green, light | \$5 00 | Bronze Green | \$4 00 | Silk Green, light | \$1 50 |
| Brilliant Green, deep | 5 00 | Green Lake | 3 00 | Olive Green | 2 00 |
| Victoria Green, dark | 5 00 | Gloss Green | 3 00 | Poster Green, light | 0 50 |
| Victoria Green, light | 4 00 | Silk Green, dark | 2 00 | Poster Green, dark | 0 50 |
| Viridin Blue | 5 00 | Silk Green, medium | 2 00 | | |

YELLOW INKS.

| | | | | | |
|--------------------------------|--------|--------------------------------|--------|--------------------------|--------|
| Chrome Yellow, deep | \$2 00 | Zinc Yellow | \$2 00 | Label Yellow | \$2 00 |
| Chrome Yellow, light | 2 00 | Persian Yellow | 2 00 | Yellow, medium | 1 00 |
| Chrome Orange | 2 00 | Sulphur Yellow, dark | 2 00 | Poster Yellow | 0 50 |

PURPLE INKS.

| | | | |
|--------------------------------|---------|----------------------------|--------|
| Violet Lake, reddish | \$10 00 | Brilliant Violet | \$4 00 |
| Violet Lake, bluish | 8 00 | Violet No. 1 | 4 00 |

GOLD INK.

| | | | |
|---------------------|--------|---------------------|--------|
| Pale Gold | \$5 00 | Rich Gold | \$5 00 |
|---------------------|--------|---------------------|--------|

WHITE INKS.

| | | | |
|--|--------|---------------------------------|--------|
| Ex. Fine Body White (prints white) | \$1 50 | Fine White, for tints | \$1 00 |
| Poster White | \$0 50 | | |

TINT INKS.

| | |
|---|--------|
| Any shade (twelve shades kept in stock, as per Ink Specimen Book) | \$1 00 |
|---|--------|

SILK INKS.

| | | | |
|-------------------------------|--------|----------------------------|--------|
| Silk Amaranth | \$5 00 | Silk Dark Blue | \$5 00 |
| Silk Red | 5 00 | Silk Violet | 5 00 |
| Silk Grass Green | 5 00 | Silk Purple | 5 00 |
| Silk Blue Green | 5 00 | Silk Dark Purple | 5 00 |
| Celestial Silk Blue | 5 00 | Silk Light Brown | 5 00 |

COPYABLE INKS.

| | | | | | |
|------------------|--------|----------------|--------|-------------------|--------|
| Purple | \$5 00 | Red | \$5 00 | Scarlet | \$5 00 |
| Black | 5 00 | Blue | 5 00 | Green | 5 00 |

GLOSS INKS.

| | Per lb. | | Per lb. | | Per lb. |
|----------------------|---------|-----------------------|---------|-----------------------|---------|
| Gloss Red | \$3 00 | Gloss Green | \$3 00 | Gloss Black | \$2 00 |
| Gloss Blue | 3 00 | Gloss Brown | 3 00 | | |

TYPEWRITER-EFFECT INKS.

| | | | |
|-----------------------------|--------|----------------------------|--------|
| Blue Typewriter | \$2 50 | Green Typewriter | \$2 50 |
| Purple Typewriter | 2 50 | | |

THREE-COLOR PROCESS INKS.

| | | | |
|------------------------------------|--------|--------------------------------------|--------|
| Three-color Process Red | \$4 50 | Three-color Process Yellow | \$3 00 |
| Three-color Process Blue | 4 00 | | |

REDUCING VARNISHES.**FOR REDUCING COLORED AND FINE BLACK INKS.**

| | Per lb. | Per gal. |
|--|---------|----------|
| Pure Linseed, bleached, A, very soft | \$0 50 | \$2 25 |
| Pure Linseed, bleached, B, soft | 0 55 | 2 25 |
| Pure Linseed, bleached, C, medium | 0 60 | 2 50 |

ORDINARY, FOR REDUCING BLACK INKS.

| | | |
|--------------------|--------|--------|
| Ordinary | \$0 30 | \$1 00 |
|--------------------|--------|--------|

GLOSS VARNISHES.

| | Per lb. |
|--|---------|
| Transparent Gloss Varnish, for mixing into inks | \$1 50 |
| Body Gloss Varnish, for printing over black and colored inks | 1 50 |

DRYERS.

| | |
|---|--------|
| Body Dryer, will not reduce consistency or body of inks | \$1 50 |
| Fluid Dryer | 1 50 |

NOTE—From one to two per cent. of above dryers can be safely used in colored inks, and from three to eight per cent. in black inks.

BRONZE INKS.

| | | |
|-----------------------------|----------------------------|------------------------------|
| Bronze Carmine . . . \$5 00 | Bronze Green . . . \$4 00 | Bronze Blue No. 1 . . \$2 50 |
| Bronze Red 4 00 | Deep Br'ze Blue No. 1 2 50 | Bronze Blue No. 2 . . 2 50 |

BRONZE SIZE.

| | |
|-------------------------------------|--------|
| Yellow | \$1 50 |
| White, for silver bronzes | 1 50 |

BRONZE POWDERS.

| | Per oz. | Per lb. |
|--|---------|---------|
| Extra Fine Brilliant Rich Gold No. 1 | \$0 40 | \$3 50 |
| Extra Fine Brilliant Pale Gold No. 1 | 0 45 | 4 50 |
| Extra Fine Brilliant No. 1, Crimson, Copper, Fire or Green | 0 45 | 4 50 |
| Extra Brilliant Rich "Electra" Gold No. 2 | 0 35 | 3 00 |
| Extra Brilliant Pale "Electra" Gold No. 2 | 0 40 | 4 00 |
| Brilliant Pale Gold No. 3 | 0 25 | 2 00 |
| Brilliant Rich Gold No. 3 | 0 25 | 2 00 |
| Brilliant No. 3, Crimson, Copper, Fire or Green | | 3 00 |
| Rich or Pale Gold, grade A | | 1 00 |
| Rich or Pale Gold, grade B | | 1 25 |
| Silver No. 1 | 0 50 | 5 00 |
| Silver No. 2 | 0 40 | 3 50 |
| Silver No. 3 | 0 25 | 2 50 |
| Aluminum | 0 40 | 4 00 |
| Patent Bronzes (Light Blue, Dark Blue, Blue-Green, Deep Green, Sea-Green, Yellow-Green, Amaranth and Violet) | 0 40 | 4 00 |

PART XXI.

Useful Information
FOR
Printers



NUMBER OF EMS IN ONE POUND OF TYPE.

Two by two inches (four square inches) solid type weighs approximately one pound :

| | | | | | |
|--------------------|------------|-------------------|------------|--------------------|------------|
| 5 Point | EMS 829 | 7 Point | EMS 423 | 10 Point | EMS 207 |
| 5½ Point | 685 | 8 Point | 324 | 11 Point | 171 |
| 6 Point | 576 | 9 Point | 256 | 12 Point | 144 |

NUMBER OF EMS IN SQUARE INCHES OF TYPE.

[Copyrighted by D. Ramaley.]

| SQ. IN. | 6 PT. | 7 PT. | 8 PT. | 9 PT. | 10 PT. | 11 PT. | 12 PT. | SQ. IN. | 6 PT. | 7 PT. | 8 PT. | 9 PT. | 10 PT. | 11 PT. | 12 PT. |
|----------|-------|-------|-------|-------|--------|--------|--------|-----------|-------|-------|-------|-------|--------|--------|--------|
| 1 . . . | 144 | 106 | 81 | 64 | 52 | 43 | 36 | 29 . . . | 4176 | 3074 | 2349 | 1856 | 1508 | 1249 | 1044 |
| 2 . . . | 288 | 212 | 162 | 128 | 104 | 86 | 72 | 30 . . . | 4320 | 3180 | 2430 | 1920 | 1560 | 1292 | 1080 |
| 3 . . . | 432 | 318 | 243 | 192 | 156 | 129 | 108 | 31 . . . | 4464 | 3286 | 2511 | 1984 | 1612 | 1335 | 1116 |
| 4 . . . | 576 | 424 | 324 | 256 | 208 | 172 | 144 | 32 . . . | 4608 | 3392 | 2592 | 2048 | 1664 | 1378 | 1152 |
| 5 . . . | 720 | 530 | 405 | 320 | 260 | 215 | 180 | 33 . . . | 4752 | 3498 | 2673 | 2112 | 1716 | 1421 | 1188 |
| 6 . . . | 864 | 636 | 486 | 384 | 312 | 258 | 216 | 34 . . . | 4896 | 3604 | 2754 | 2176 | 1768 | 1464 | 1224 |
| 7 . . . | 1008 | 742 | 567 | 448 | 364 | 301 | 252 | 35 . . . | 5040 | 3710 | 2835 | 2240 | 1820 | 1507 | 1260 |
| 8 . . . | 1152 | 848 | 648 | 512 | 416 | 348 | 288 | 36 . . . | 5184 | 3816 | 2916 | 2304 | 1872 | 1550 | 1296 |
| 9 . . . | 1296 | 954 | 729 | 576 | 468 | 387 | 324 | 37 . . . | 5328 | 3922 | 2997 | 2368 | 1924 | 1593 | 1332 |
| 10 . . . | 1440 | 1060 | 810 | 640 | 520 | 430 | 360 | 38 . . . | 5472 | 4028 | 3078 | 2432 | 1976 | 1636 | 1368 |
| 11 . . . | 1584 | 1166 | 891 | 704 | 572 | 473 | 396 | 39 . . . | 5616 | 4134 | 3159 | 2496 | 2028 | 1679 | 1404 |
| 12 . . . | 1728 | 1272 | 972 | 768 | 624 | 516 | 432 | 40 . . . | 5760 | 4240 | 3240 | 2560 | 2080 | 1722 | 1440 |
| 13 . . . | 1872 | 1378 | 1053 | 832 | 676 | 559 | 468 | 41 . . . | 5904 | 4346 | 3321 | 2624 | 2132 | 1765 | 1476 |
| 14 . . . | 2016 | 1484 | 1134 | 896 | 728 | 602 | 504 | 42 . . . | 6048 | 4452 | 3402 | 2688 | 2184 | 1808 | 1512 |
| 15 . . . | 2160 | 1590 | 1215 | 960 | 780 | 645 | 540 | 43 . . . | 6192 | 4558 | 3483 | 2752 | 2236 | 1851 | 1548 |
| 16 . . . | 2304 | 1696 | 1296 | 1024 | 832 | 688 | 576 | 44 . . . | 6336 | 4664 | 3564 | 2816 | 2288 | 1894 | 1584 |
| 17 . . . | 2448 | 1802 | 1377 | 1088 | 884 | 733 | 612 | 45 . . . | 6480 | 4770 | 3645 | 2880 | 2340 | 1937 | 1620 |
| 18 . . . | 2592 | 1908 | 1458 | 1152 | 936 | 776 | 648 | 46 . . . | 6624 | 4876 | 3726 | 2944 | 2392 | 1980 | 1650 |
| 19 . . . | 2736 | 2014 | 1539 | 1216 | 988 | 819 | 684 | 47 . . . | 6768 | 4982 | 3807 | 3008 | 2444 | 2023 | 1696 |
| 20 . . . | 2880 | 2120 | 1620 | 1280 | 1040 | 862 | 720 | 48 . . . | 6912 | 5088 | 3888 | 3072 | 2496 | 2066 | 1728 |
| 21 . . . | 3024 | 2226 | 1701 | 1344 | 1092 | 905 | 756 | 49 . . . | 7056 | 5194 | 3969 | 3136 | 2548 | 2109 | 1764 |
| 22 . . . | 3168 | 2332 | 1782 | 1408 | 1144 | 948 | 792 | 50 . . . | 7200 | 5300 | 4050 | 3200 | 2600 | 2152 | 1800 |
| 23 . . . | 3312 | 2438 | 1863 | 1472 | 1196 | 991 | 828 | 51 . . . | 7344 | 5406 | 4131 | 3264 | 2652 | 2194 | 1836 |
| 24 . . . | 3456 | 2544 | 1944 | 1536 | 1248 | 1034 | 864 | 52 . . . | 7488 | 5512 | 4212 | 3328 | 2704 | 2236 | 1872 |
| 25 . . . | 3600 | 2650 | 2025 | 1600 | 1300 | 1077 | 900 | 53 . . . | 7632 | 5618 | 4293 | 3392 | 2756 | 2278 | 1908 |
| 26 . . . | 3744 | 2756 | 2106 | 1664 | 1352 | 1120 | 936 | 54 . . . | 7776 | 5724 | 4374 | 3456 | 2808 | 2320 | 1944 |
| 27 . . . | 3888 | 2862 | 2187 | 1728 | 1404 | 1163 | 972 | 55 . . . | 7920 | 5830 | 4455 | 3520 | 2860 | 2362 | 1980 |
| 28 . . . | 4032 | 2968 | 2268 | 1792 | 1456 | 1206 | 1008 | 56 . . . | 8064 | 5936 | 4536 | 3584 | 2912 | 2404 | 2016 |
| | | | | | | | | 57 . . . | 8208 | 6042 | 4617 | 3648 | 2964 | 2446 | 2052 |
| | | | | | | | | 58 . . . | 8352 | 6148 | 4698 | 3712 | 3016 | 2488 | 2088 |
| | | | | | | | | 59 . . . | 8496 | 6254 | 4779 | 3776 | 3068 | 2530 | 2124 |
| | | | | | | | | 60 . . . | 8640 | 6360 | 4860 | 3840 | 3120 | 2572 | 2160 |
| | | | | | | | | 61 . . . | 8784 | 6466 | 4941 | 3904 | 3172 | 2614 | 2196 |
| | | | | | | | | 62 . . . | 8928 | 6572 | 5022 | 3968 | 3224 | 2656 | 2232 |
| | | | | | | | | 63 . . . | 9072 | 6678 | 5103 | 4032 | 3276 | 2698 | 2268 |
| | | | | | | | | 64 . . . | 9216 | 6784 | 5184 | 4096 | 3328 | 2740 | 2304 |
| | | | | | | | | 65 . . . | 9360 | 6890 | 5265 | 4160 | 3380 | 2782 | 2340 |
| | | | | | | | | 66 . . . | 9504 | 6996 | 5346 | 4224 | 3432 | 2824 | 2376 |
| | | | | | | | | 67 . . . | 9648 | 7102 | 5427 | 4288 | 3484 | 2866 | 2412 |
| | | | | | | | | 68 . . . | 9792 | 7208 | 5508 | 4352 | 3536 | 2908 | 2448 |
| | | | | | | | | 69 . . . | 9936 | 7314 | 5589 | 4416 | 3588 | 2950 | 2484 |
| | | | | | | | | 70 . . . | 10080 | 7420 | 5670 | 4480 | 3640 | 3010 | 2520 |
| | | | | | | | | 71 . . . | 10224 | 7526 | 5751 | 4544 | 3692 | 3052 | 2556 |
| | | | | | | | | 72 . . . | 10368 | 7632 | 5832 | 4608 | 3744 | 3094 | 2592 |
| | | | | | | | | 73 . . . | 10512 | 7738 | 5913 | 4672 | 3796 | 3136 | 2628 |
| | | | | | | | | 74 . . . | 10656 | 7844 | 5994 | 4736 | 3848 | 3178 | 2664 |
| | | | | | | | | 75 . . . | 10800 | 7950 | 6075 | 4800 | 3900 | 3220 | 2700 |
| | | | | | | | | 76 . . . | 10944 | 8056 | 6156 | 4864 | 3952 | 3262 | 2736 |
| | | | | | | | | 77 . . . | 11088 | 8162 | 6237 | 4928 | 4004 | 3304 | 2772 |
| | | | | | | | | 78 . . . | 11232 | 8268 | 6318 | 4992 | 4056 | 3346 | 2808 |
| | | | | | | | | 79 . . . | 11376 | 8374 | 6399 | 5056 | 4108 | 3388 | 2844 |
| | | | | | | | | 80 . . . | 11520 | 8480 | 6480 | 5120 | 4160 | 3430 | 2880 |
| | | | | | | | | 81 . . . | 11664 | 8586 | 6561 | 5184 | 4212 | 3472 | 2916 |
| | | | | | | | | 82 . . . | 11808 | 8692 | 6642 | 5248 | 4264 | 3514 | 2952 |
| | | | | | | | | 83 . . . | 11952 | 8798 | 6723 | 5312 | 4316 | 3556 | 2988 |
| | | | | | | | | 84 . . . | 12096 | 8904 | 6804 | 5376 | 4368 | 3598 | 3024 |
| | | | | | | | | 85 . . . | 12240 | 9010 | 6885 | 5440 | 4420 | 3640 | 3060 |
| | | | | | | | | 86 . . . | 12384 | 9116 | 6966 | 5504 | 4472 | 3682 | 3096 |
| | | | | | | | | 87 . . . | 12528 | 9222 | 7047 | 5568 | 4524 | 3724 | 3132 |
| | | | | | | | | 88 . . . | 12672 | 9328 | 7128 | 5632 | 4576 | 3766 | 3168 |
| | | | | | | | | 89 . . . | 12816 | 9434 | 7209 | 5696 | 4628 | 3808 | 3204 |
| | | | | | | | | 90 . . . | 12960 | 9540 | 7290 | 5760 | 4680 | 3850 | 3240 |
| | | | | | | | | 91 . . . | 13104 | 9646 | 7371 | 5824 | 4732 | 3892 | 3276 |
| | | | | | | | | 92 . . . | 13248 | 9752 | 7452 | 5888 | 4784 | 3934 | 3312 |
| | | | | | | | | 93 . . . | 13392 | 9858 | 7533 | 5952 | 4836 | 3976 | 3348 |
| | | | | | | | | 94 . . . | 13536 | 9964 | 7614 | 6016 | 4888 | 4018 | 3384 |
| | | | | | | | | 95 . . . | 13680 | 10070 | 7695 | 6080 | 4940 | 4060 | 3420 |
| | | | | | | | | 96 . . . | 13824 | 10176 | 7776 | 6144 | 4992 | 4102 | 3456 |
| | | | | | | | | 97 . . . | 13968 | 10282 | 7857 | 6208 | 5044 | 4144 | 3492 |
| | | | | | | | | 98 . . . | 14112 | 10388 | 7938 | 6272 | 5096 | 4186 | 3528 |
| | | | | | | | | 99 . . . | 14256 | 10494 | 8019 | 6336 | 5148 | 4228 | 3564 |
| | | | | | | | | 100 . . . | 14400 | 10600 | 8100 | 6400 | 5200 | 4270 | 3600 |

NUMBER OF LEADS TO THE POUND.

Table showing the approximate number of 2-point and 3-point leads contained in a pound. For 1-point leads, multiply the 2-point columns by 2. For 1½-point leads, multiply the 3-point columns by 2.

| EMS LONG | 2 POINT | 3 POINT | EMS LONG | 2 POINT | 3 POINT | EMS LONG | 2 POINT | 3 POINT | EMS LONG | 2 POINT | 3 POINT |
|----------|---------|---------|----------|---------|---------|----------|---------|---------|----------|---------|---------|
| 3 | 288 | 192 | 15 | 57 | 38 | 27 | 31 | 21 | 39 | 22 | 15 |
| 4 | 216 | 144 | 16 | 54 | 36 | 28 | 30 | 20 | 40 | 21 | 14 |
| 5 | 168 | 112 | 17 | 51 | 34 | 29 | 30 | 20 | 41 | 21 | 14 |
| 6 | 144 | 96 | 18 | 48 | 32 | 30 | 29 | 19 | 42 | 20 | 14 |
| 7 | 123 | 82 | 19 | 45 | 30 | 31 | 28 | 19 | 43 | 20 | 13 |
| 8 | 108 | 72 | 20 | 42 | 28 | 32 | 27 | 18 | 44 | 19 | 13 |
| 9 | 96 | 64 | 21 | 40 | 27 | 33 | 26 | 17 | 45 | 19 | 13 |
| 10 | 84 | 56 | 22 | 39 | 26 | 34 | 25 | 17 | 46 | 18 | 12 |
| 11 | 78 | 52 | 23 | 37 | 25 | 35 | 24 | 16 | 47 | 18 | 12 |
| 12 | 72 | 48 | 24 | 36 | 24 | 36 | 24 | 16 | 48 | 18 | 12 |
| 13 | 66 | 44 | 25 | 34 | 23 | 37 | 23 | 15 | 49 | 17 | 11 |
| 14 | 61 | 41 | 26 | 33 | 22 | 38 | 22 | 15 | 50 | 17 | 11 |

ROMAN NUMERALS.

| | | | | | | | |
|-------|--------|---------|----------|--------|---------|----------|-----------|
| I—1 | VI—6 | XI—11 | XVI—16 | XXX—30 | LXXX—80 | CCC—300 | DCCC—800 |
| II—2 | VII—7 | XII—12 | XVII—17 | XL—40 | XC—90 | CCCC—400 | DCCCC—900 |
| III—3 | VIII—8 | XIII—13 | XVIII—18 | L—50 | C—100 | D—500 | M—1000 |
| IV—4 | IX—9 | XIV—14 | XIX—19 | LX—60 | CL—150 | DC—600 | |
| V—5 | X—10 | XV—15 | XX—20 | LXX—70 | CC—200 | DCC—700 | |

APPROXIMATE NUMBER OF WORDS IN A SQUARE INCH.

In calculating the number of pages a manuscript will occupy, these figures may be used:

| WORDS TO SQ. IN. | | WORDS TO SQ. IN. | | WORDS TO SQ. IN. | |
|----------------------------|----|----------------------------|----|---------------------------|----|
| 18 Point, solid | 7 | 10 Point, solid | 21 | 7 Point, solid | 38 |
| 14 Point, solid | 11 | 10 Point, leaded | 16 | 7 Point, leaded | 27 |
| 12 Point, solid | 14 | 9 Point, solid | 28 | 6 Point, solid | 47 |
| 12 Point, leaded | 11 | 9 Point, leaded | 21 | 6 Point, leaded | 34 |
| 11 Point, solid | 17 | 8 Point, solid | 32 | 5 Point, solid | 69 |
| 11 Point, leaded | 14 | 8 Point, leaded | 23 | 5 Point, leaded | 50 |

“Leaded,” as here used, means an opening of lines with 2-point leads.

USEFUL IN ORDERING SORTS.

In ordering sorts *always* send a cap H and lower-case m of the font you wish to match. These letters should be sent, no matter what the characters are that you wish to purchase. The following table shows what each box in the type case will hold :

| | | |
|---------------------------|----------------------------|------------|
| a c d i s m n h o u t r | boxes, each hold | 2 pounds. |
| f b l v g y p w | boxes, each hold | 15 ounces. |
| k j z x q and all figures | boxes, each hold | 6 ounces. |
| e | box holds | 3 pounds. |
| Caps and small caps | boxes, each hold | 5 ounces. |

TO PRINT CONSECUTIVE NUMBERS.

Orders to print consecutive numbers are received more or less frequently by every printing office, large or small. In the average office, to print the numbers 1 to 200 consecutively would be quite a task, and when undertaken in the ordinary way, with the facilities usually at hand, the cost is so high that the customer usually concludes to get along with something else than printed numbers, and what might be a profitable job is lost to the office.

| A | B | C | D | E | F | G | H | I | K | L |
|---|----|----|----|----|----|----|----|----|----|----|
| 1 | 11 | 21 | 31 | 41 | 51 | 61 | 71 | 81 | 91 | 01 |
| 2 | 22 | 32 | 42 | 52 | 62 | 72 | 82 | 92 | 02 | 12 |
| 3 | 33 | 43 | 53 | 63 | 73 | 83 | 93 | 03 | 13 | 23 |
| 4 | 44 | 54 | 64 | 74 | 84 | 94 | 04 | 14 | 24 | 34 |
| 5 | 55 | 65 | 75 | 85 | 95 | 05 | 15 | 25 | 35 | 45 |
| 6 | 66 | 76 | 86 | 96 | 06 | 16 | 26 | 36 | 46 | 56 |
| 7 | 77 | 87 | 97 | 07 | 17 | 27 | 37 | 47 | 57 | 67 |
| 8 | 88 | 98 | 08 | 18 | 28 | 38 | 48 | 58 | 68 | 78 |
| 9 | 99 | 09 | 19 | 29 | 39 | 49 | 59 | 69 | 79 | 89 |
| 0 | 00 | 10 | 20 | 30 | 40 | 50 | 60 | 70 | 80 | 90 |

Suppose an order for two hundred reserved seat numbers from 1 to 200, six copies of each. It is not necessary to set up more than the units 1 to 0. These figures are to be set up, properly spaced, one above the other, as shown in column A of the table annexed.

One hundred and twenty impressions are taken on strips of cardboard cut to the required width. This done, gives the required number of units. Change the gauge pins in a manner to print the same form beside the printed figures to form the tens, as shown in column B of the table. Take twelve impressions of this form on twelve of the already-printed strips. The next step is to change the form by taking the top figure (1) and place it at the bottom of the column, so the next impression on a strip of the first form will read as shown in column C of the table. We print again twelve strips of the first form. This change of the top figures, 2, 3, 4, 5, 6, 7, 8, 9 and 0, respectively, is repeated eight more times, shown in the table as columns D, E, F, G, H, I, K and L. From each change twelve impressions on the printed slips containing the first form must be made. This will finish the tens, and by changing the form to ten figure 1s and again moving the pins to the left for the space-width of the type, and printing six strips of each the former changes from B to L, gives the hundreds, or a continuous run of numbers from 1 to 199 in an edition of six copies. To obtain number 200, print upon the six strips left a figure 2 to head the 00 of column B. In assorting the numbers it will be found that each six copies of the heavy type cannot be used, but this small loss in stock is compensated many times by the advantage derived from the method.

PROOFREADER'S MARKS.

- X** Change bad letter.
- L** Push down space.
- 9** Turn.
- 8** Take out (*dele*).
- ^** Left out; insert.
- #** Insert space.
- v** Even spacing.
- u** Less space.
- C** Close up entirely.
- ⊙** Period.
- /** Comma.
- ⊕** Colon.
- ;** Semicolon.
- ʹ** Apostrophe.
- “ ”** Quotation.
- /-** Hyphen.
- |||** Straighten lines.
- Move over.
- Em-quad space.
- /-/** One-em dash.
- /-2/** Two-em dash.
- ¶** Paragraph.
- No ¶ No paragraph.
- w. f.* Wrong font.
- ... Let it stand.
- stet.* Let it stand.
- tr.* Transpose.
- Caps* Capital letters.
- s. c.* Small caps.
- l. c.* Lower case or small letters.
- Ital.* Italics.
- Rom.* Roman.

TABLE SHOWING THE AMOUNT OF PAPER REQUIRED

for any job of from 50 to 5000 copies. No allowance is made for waste.

| NO. OF COPIES REQUIRED. | 2 | | 3 | | 4 | | 6 | | 8 | | 9 | | 12 | | 15 | | 16 | | 18 | | 20 | | 24 | | 32 | |
|----------------------------|--------------|--------|--------------|--------|--------------|--------|--------------|--------|--------------|--------|--------------|--------|--------------|--------|--------------|--------|--------------|--------|--------------|--------|--------------|--------|--------------|--------|--------------|--------|
| | TO THE SHEET | | TO THE SHEET | | TO THE SHEET | | TO THE SHEET | | TO THE SHEET | | TO THE SHEET | | TO THE SHEET | | TO THE SHEET | | TO THE SHEET | | TO THE SHEET | | TO THE SHEET | | TO THE SHEET | | TO THE SHEET | |
| | QUIRES | SHEETS | QUIRES | SHEETS | QUIRES | SHEETS | QUIRES | SHEETS | QUIRES | SHEETS | QUIRES | SHEETS | QUIRES | SHEETS | QUIRES | SHEETS | QUIRES | SHEETS | QUIRES | SHEETS | QUIRES | SHEETS | QUIRES | SHEETS | QUIRES | SHEETS |
| 50 | 1-1 | 0-17 | 0-13 | 0-9 | 0-9 | 0-7 | 0-6 | 0-5 | 0-4 | 0-4 | 0-4 | 0-3 | 0-3 | 0-3 | 0-3 | 0-3 | 0-3 | 0-3 | 0-3 | 0-3 | 0-3 | 0-3 | 0-3 | 0-3 | 0-3 | 0-3 |
| 100 | 2-2 | 1-10 | 1-1 | 0-17 | 0-13 | 0-12 | 0-9 | 0-7 | 0-7 | 0-7 | 0-7 | 0-6 | 0-5 | 0-4 | 0-4 | 0-4 | 0-4 | 0-4 | 0-4 | 0-4 | 0-4 | 0-4 | 0-4 | 0-4 | 0-4 | 0-4 |
| 200 | 4-4 | 2-19 | 2-2 | 1-10 | 1-1 | 0-23 | 0-17 | 0-14 | 0-13 | 0-12 | 0-9 | 0-7 | 0-7 | 0-7 | 0-7 | 0-7 | 0-7 | 0-7 | 0-7 | 0-7 | 0-7 | 0-7 | 0-7 | 0-7 | 0-7 | 0-7 |
| 250 | 5-5 | 3-12 | 2-15 | 1-18 | 1-8 | 1-4 | 0-21 | 0-17 | 0-16 | 0-14 | 0-11 | 0-10 | 0-9 | 0-8 | 0-7 | 0-7 | 0-7 | 0-7 | 0-7 | 0-7 | 0-7 | 0-7 | 0-7 | 0-7 | 0-7 | 0-7 |
| 300 | 6-6 | 4-4 | 3-3 | 2-2 | 1-14 | 1-10 | 1-1 | 0-20 | 0-19 | 0-17 | 0-14 | 0-11 | 0-10 | 0-9 | 0-8 | 0-7 | 0-7 | 0-7 | 0-7 | 0-7 | 0-7 | 0-7 | 0-7 | 0-7 | 0-7 | 0-7 |
| 400 | 8-8 | 5-14 | 4-4 | 2-19 | 2-2 | 1-21 | 1-10 | 1-3 | 1-1 | 0-23 | 0-20 | 0-17 | 0-13 | 0-10 | 0-9 | 0-8 | 0-7 | 0-7 | 0-7 | 0-7 | 0-7 | 0-7 | 0-7 | 0-7 | 0-7 | 0-7 |
| 500 | 10-10 | 6-23 | 5-5 | 3-12 | 2-15 | 2-8 | 1-18 | 1-10 | 1-8 | 1-4 | 1-1 | 0-21 | 0-19 | 0-16 | 0-14 | 0-11 | 0-10 | 0-9 | 0-8 | 0-7 | 0-7 | 0-7 | 0-7 | 0-7 | 0-7 | 0-7 |
| 600 | 12-12 | 8-8 | 6-6 | 4-4 | 3-3 | 2-19 | 2-2 | 1-16 | 1-14 | 1-10 | 1-6 | 1-1 | 0-19 | 0-17 | 0-14 | 0-11 | 0-10 | 0-9 | 0-8 | 0-7 | 0-7 | 0-7 | 0-7 | 0-7 | 0-7 | 0-7 |
| 700 | 14-14 | 9-18 | 7-7 | 4-21 | 3-16 | 3-6 | 2-11 | 1-23 | 1-20 | 1-15 | 1-11 | 1-6 | 0-22 | 0-19 | 0-16 | 0-13 | 0-10 | 0-9 | 0-8 | 0-7 | 0-7 | 0-7 | 0-7 | 0-7 | 0-7 | 0-7 |
| 750 | 15-15 | 10-10 | 7-20 | 5-5 | 3-22 | 3-12 | 2-15 | 2-3 | 1-23 | 1-18 | 1-14 | 1-8 | 1-0 | 0-21 | 0-18 | 0-15 | 0-12 | 0-9 | 0-8 | 0-7 | 0-7 | 0-7 | 0-7 | 0-7 | 0-7 | 0-7 |
| 800 | 16-16 | 11-3 | 8-8 | 5-14 | 4-4 | 3-17 | 2-19 | 2-6 | 2-2 | 1-21 | 1-16 | 1-10 | 1-1 | 0-20 | 0-17 | 0-14 | 0-11 | 0-10 | 0-9 | 0-8 | 0-7 | 0-7 | 0-7 | 0-7 | 0-7 | 0-7 |
| 900 | 18-18 | 12-12 | 9-9 | 6-6 | 4-17 | 4-4 | 3-3 | 2-12 | 2-9 | 2-2 | 1-21 | 1-14 | 1-5 | 0-20 | 0-17 | 0-14 | 0-11 | 0-10 | 0-9 | 0-8 | 0-7 | 0-7 | 0-7 | 0-7 | 0-7 | 0-7 |
| 1000 | 20-20 | 13-22 | 10-10 | 6-23 | 5-5 | 4-16 | 3-12 | 2-19 | 2-15 | 2-8 | 2-2 | 1-18 | 1-1 | 0-20 | 0-17 | 0-14 | 0-11 | 0-10 | 0-9 | 0-8 | 0-7 | 0-7 | 0-7 | 0-7 | 0-7 | 0-7 |
| 1250 | 26-1 | 17-9 | 13-1 | 8-17 | 6-13 | 5-19 | 4-9 | 3-12 | 3-7 | 2-22 | 2-15 | 2-5 | 1-16 | 0-21 | 0-18 | 0-15 | 0-12 | 0-9 | 0-8 | 0-7 | 0-7 | 0-7 | 0-7 | 0-7 | 0-7 | 0-7 |
| 1500 | 31-6 | 20-20 | 15-15 | 10-10 | 7-20 | 6-23 | 5-5 | 4-5 | 3-22 | 3-12 | 3-3 | 2-15 | 1-23 | 0-21 | 0-18 | 0-15 | 0-12 | 0-9 | 0-8 | 0-7 | 0-7 | 0-7 | 0-7 | 0-7 | 0-7 | 0-7 |
| 1750 | 36-11 | 24-8 | 18-6 | 12-4 | 9-3 | 8-3 | 6-2 | 4-22 | 4-14 | 4-2 | 3-16 | 3-1 | 2-8 | 1-16 | 1-10 | 0-13 | 0-10 | 0-7 | 0-6 | 0-5 | 0-4 | 0-4 | 0-4 | 0-4 | 0-4 | 0-4 |
| 2000 | 41-16 | 27-19 | 20-20 | 13-22 | 10-10 | 9-7 | 6-23 | 5-14 | 5-5 | 4-16 | 4-4 | 3-12 | 2-15 | 1-16 | 1-10 | 0-13 | 0-10 | 0-7 | 0-6 | 0-5 | 0-4 | 0-4 | 0-4 | 0-4 | 0-4 | 0-4 |
| 2500 | 52-2 | 31-18 | 26-1 | 17-10 | 13-1 | 11-15 | 8-17 | 7-0 | 6-13 | 5-20 | 5-5 | 4-9 | 3-7 | 2-22 | 2-15 | 2-5 | 1-16 | 0-21 | 0-18 | 0-15 | 0-12 | 0-9 | 0-8 | 0-7 | 0-7 | 0-7 |
| 3000 | 62-12 | 44-16 | 31-6 | 20-20 | 15-15 | 13-22 | 10-10 | 8-8 | 7-20 | 6-23 | 6-6 | 5-5 | 4-9 | 3-7 | 2-22 | 2-15 | 2-5 | 1-16 | 0-21 | 0-18 | 0-15 | 0-12 | 0-9 | 0-8 | 0-7 | 0-7 |
| 4000 | 83-8 | 55-14 | 41-16 | 27-19 | 20-20 | 18-13 | 13-22 | 11-3 | 10-10 | 9-7 | 8-8 | 7-20 | 6-23 | 6-6 | 5-5 | 4-9 | 3-7 | 2-22 | 2-15 | 2-5 | 1-16 | 0-21 | 0-18 | 0-15 | 0-12 | 0-9 |
| 5000 | 104-4 | 69-11 | 52-2 | 34-18 | 26-1 | 23-4 | 17-9 | 13-22 | 13-1 | 11-14 | 10-10 | 9-7 | 8-8 | 7-20 | 6-23 | 6-6 | 5-5 | 4-9 | 3-7 | 2-22 | 2-15 | 2-5 | 1-16 | 0-21 | 0-18 | 0-15 |

DIRECTIONS FOR SECURING COPYRIGHTS

Under the Revised Acts of Congress, including the Provisions for Foreign Copyright, by Act of March 3, 1891.

Printed title required. 1. A *printed* copy of the title of the book, map or chart, dramatic or musical composition, engraving, cut, print, photograph or chromo, or a *description* of the painting, drawing, statue, statuary or model or design for a work of the fine arts, for which copyright is desired, must be delivered to the Librarian of Congress or deposited in the mail, within the United States, *prepaid*, addressed "LIBRARIAN OF CONGRESS, WASHINGTON, D. C." This must be done on or before day of publication in this or any foreign country.

What style of print. The *printed title* required may be a copy of the title page of such publications as have title pages. *In other cases the title must be printed expressly for copyright entry*, with name of claimant of copyright. The style of type is immaterial, and the print of a typewriter will be accepted. But a separate title is required for each entry, and *each* title must be printed on paper as large as commercial note. The title of a *periodical* must include the date and number; and each number of the periodical requires a separate entry of copyright.

Copyright fees. 2. The legal fee for *recording* each copyright claim is 50 cents, and for a *copy* of this record (or certificate of copyright under seal of the office) an additional fee of 50 cents is required, making \$1 if certificate is wanted, which will be mailed as soon as reached in the records.

For publications which are the production of persons not citizens or residents of the United States, the fee for recording title is \$1, and 50 cents additional for a copy of the record. Certificates covering more than one entry in one certificate are not issued.

Two copies required. 3. Not later than the day of publication in this country or abroad, two complete copies of the best edition of each book or other article must be delivered, or deposited in the mail within the United States, addressed "LIBRARIAN OF CONGRESS, WASHINGTON, D. C.," to perfect the copyright.

The freight or postage must be prepaid, or the publications inclosed in parcels covered by printed Penalty Labels, furnished by the Librarian, in which case they will come

Free by mail. FREE by mail (*not express*), without limit of weight, according to rulings of the Post Office Department. Books must be printed from type set or plates made in the United States; photographs from negatives made in the United States; chromos and lithographs from drawings on stone or transfers therefrom made in the United States.

To be American made.

Penalty. Without the deposit of copies above required the copyright is void, and a penalty of \$25 is incurred. No copy is required to be deposited elsewhere.

New editions. The law requires one copy of each new edition, wherein any substantial changes are made, to be deposited with the Librarian of Congress.

Notice of copyright to be given by imprint. 4. No copyright is valid unless notice is given by inserting in every copy published, on the title page or the page following, if it be a book; or if a map, chart, musical composition, print, cut, engraving, photograph, painting, drawing, chromo, statue, statuary or model or design intended to be perfected as a work of the fine arts, by inscribing upon some portion thereof, or on the substance on which the same is mounted, the following words, viz.: "*Entered according to Act of Congress, in the year—, by—, in the office of the Librarian of Congress, at Washington,*" or, at the option of the person entering the copyright, the words: "*Copyright, 19—, by—*."

Claimant's name to be printed. The law imposes a penalty of \$100 upon any person who has not obtained copyright who shall insert the notice "*Entered according to Act of Congress,*" or "*Copyright,*" etc., or words of the same import, in or upon any book or other article.

Penalty for false claim.

Translations and dramas.

5. The copyright law secures to authors and their assigns the exclusive right to translate or to dramatize any of their works; no notice or record is required to enforce this right.

Duration of copyright.

6. The original term of copyright runs for twenty-eight years. *Within six months before* the end of that time, the author or designer, or his widow or children, may secure a renewal for the further term of fourteen years, making forty-two years in all. Applications for renewal must be accompanied by a printed title and fee, and by explicit statement of ownership in the case of the author, or of relationship in the

Renewals.

case of his heirs, and must state definitely the date and place of entry of the original copyright. Within two months from date of renewal the record thereof must be advertised in an American newspaper for four weeks.

- Time of publication.** 7. The time of publication is not limited by any law or regulation, but the courts have held that it should take place within a reasonable time. A copyright may be secured for a projected as well as for a completed work ; but the law provides for no *caveat* or notice of interference—only for actual entry of title.
- Assignments.** 8. Copyrights are assignable by any instrument of writing. Such assignment, to be valid, is to be recorded in the office of the Librarian of Congress within sixty days from execution. The fee for this record and certificate is \$1, and for a certified copy of any record of assignment \$1.
- Copies or duplicate certificates.** 9. A copy of the record (or duplicate certificate) of any copyright entry will be furnished, under seal of the office, at the rate of 50 cents each.
- Serials or separate publications.** 10. In the case of books published in more than one volume, or of periodicals published in numbers, or of engravings, photographs or other articles published with variations, a copyright must be entered for each volume or part of a book, or number of a periodical, or variety, as to style, title or inscription, of any other article. To *complete* the copyright on a book published serially in a periodical, two copies of each serial part, as well as of the complete work (if published separately), should be deposited.
- Copyright for works of art.** 11. To secure copyright for a painting, statue or model or design intended to be perfected as a work of the fine arts, a definite title and description must accompany the application for copyright, and a mounted photograph of the same, as large as "cabinet size," mailed to the Librarian of Congress not later than the day of publication of the work or design.
- Fine arts.** The fine arts, for copyright purposes, include only painting and sculpture, and articles of merely ornamental and decorative art should be sent to the Patent Office, as subjects for design patents.
- No labels or names copyrighted.** 12. Copyrights cannot be granted upon trade-marks, nor upon names of companies, libraries or articles, nor upon an idea or device, nor upon prints or labels intended to be used for any article of manufacture. If protection for such names or labels is desired, application must be made to the Patent Office, where they are registered, if admitted, at a fee of \$6 for labels and \$25 for trade-marks.
- Foreign or international copyright.** 13. The provisions as to copyright entry in the United States by foreign authors, etc., by Act of Congress approved March 3, 1891 (which took effect July 1, 1891), are the same as the foregoing, except as to productions of persons not citizens or residents, which must cover return postages, and are \$1 for entry, or \$1.50 for entry and certificate of entry (equivalent to 4s. 5d. or 6s. 7d.). All publications must be delivered to the Librarian at Washington free of charge. The free penalty-labels cannot be used outside of the United States.
- Fees.** The right of citizens or subjects of a foreign nation to copyright in the United States extends by Presidential proclamations to Great Britain, France, Belgium, Switzerland, Germany, Italy, Denmark and Portugal.
- Full name of proprietor required.** 14. Every applicant for a copyright should state distinctly the full name and residence of the claimant, and whether the right is claimed as author, designer or proprietor. No affidavit or witness to the application is required.

METRIC SYSTEM OF WEIGHTS AND MEASURES.

In use in all European countries except Great Britain and Russia. In use in Mexico and South America.

The Meter, unit of length, is nearly the ten-millionth part of a quadrant of a meridian, of the distance between equator and pole. The International Standard Meter is, practically, nothing else but a length defined by the distance between two lines on a platinum-iridium bar at 0° Centigrade, deposited at the International Bureau of Weights and Measures, Paris, France.

The Liter, unit of capacity, is derived from the weight of one kilogram pure water at greatest density, a cube whose edge is one-tenth of a meter, and, therefore, the one-thousandth part of a metric ton.

The Gram, unit of weight, is a cube of pure water at greatest density, whose edge is one-hundredth of a meter, and, therefore, the one-thousandth part of a kilogram, and the one-millionth part of a metric ton.

One silver dollar weighs 25 grams, 1 dime = 2½ grams, 1 five-cent nickel = 5 grams.

THE METRIC SYSTEM SIMPLIFIED.

The following tables of the metric system of weights and measures have been simplified as much as possible by Mr. John Wilkes, of Nashville, Tenn., by omitting such denominations as are not in practical, everyday use in the countries where the system is used exclusively.

TABLES OF THE SYSTEM.

LENGTH.—The denominations in practical use are millimeters (mm.), centimeters (cm.), meters (m.), and kilometers (km.).

10 mm. = 1 cm.; 100 cm. = 1 m.; 1000 m. = 1 km.

A decimeter is 10 cm.

WEIGHT.—The denominations in use are grams (g.), kilos* (kg.), and tons (metric tons).

1000 g. = 1 kg.; 1000 kg. = 1 metric ton.

CAPACITY.—The denominations in use are cubic centimeters (c.c.), and liters (l.).

1000 c.c. = 1 l.

A hectoliter is 100 l. (seldom used).

Relation of capacity and weight to length: A cubic decimeter is a liter, and a liter of water weighs a kilo.

APPROXIMATE EQUIVALENTS.

A meter is about a yard; a kilo is about 2 lbs.; a liter is about a quart; a centimeter is about ½ inch; a metric ton is about the same as a ton; a kilometer is about ½ mile; a cubic centimeter is about a thimbleful; a nickle weighs about 5 grams.

* Contraction for kilogram.

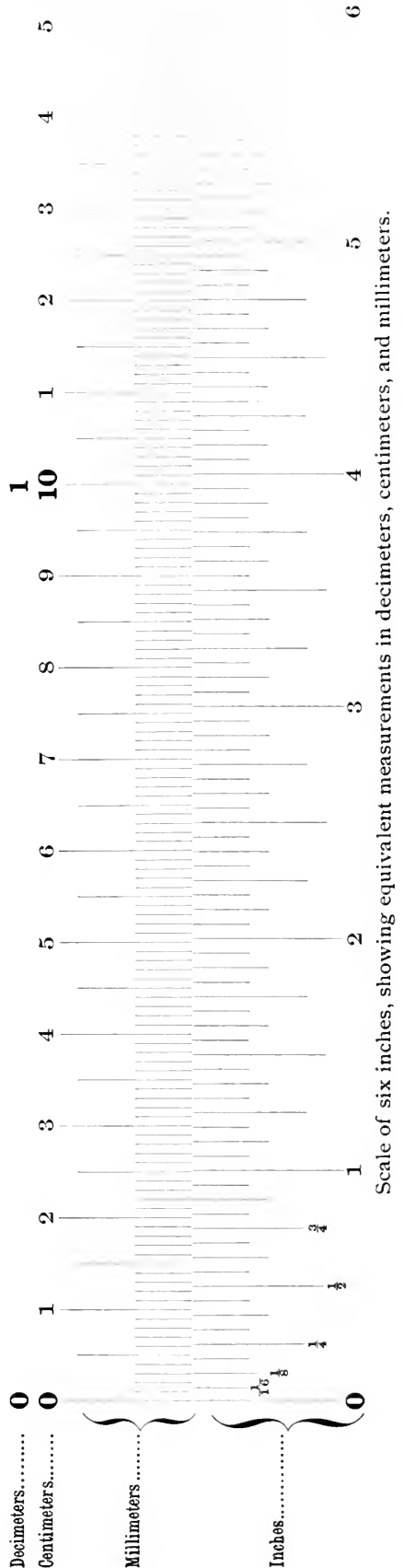

IMPOSITION OF FORMS.

HINTS ON IMPOSITION: A Hand-book for Printers. By T. B. Williams. Leather, 90 pp., \$1.00. For sale at all Branches of the American Type Founders' Company, and recommended to all who desire the fullest information concerning the imposition of forms.

The make-up should learn to use the measuring rule or tape measure and dividers. They are more convenient to measure with than paper, and their use is regarded as evidence of knowledge of the imposition of book forms. The dividers will enable the make-up to verify his measurements quickly. Printers' dividers cost 85 cents.

Ascertain what furniture will be required for the margins of a book form before placing it upon the stone. Time will be saved, and the work will have the appearance of order and neatness.

After a book form is imposed, tighten the quoins, and ascertain by means of a straight-edge or square if the pages are of equal length and the head lines or bottom folios are exactly in line. The folios are usually the guides for hand-folding and should receive great attention, otherwise the binder will not secure good register. For the same reason, folios should all be set exactly in the middle of the width of the page.

After a book form has been locked up, it should be tested for squareness with a square. Forms are liable to get twisted or bowed in locking up, especially if the chase is weak. This defect can usually be remedied by loosening the quoins on one side and tightening them on the opposite side.

MARGINS.

The proper allowances for head and back margins are matters of judgment and preference to a great degree.

The head and foot margins of a *trimmed* book are usually of equal proportions, but, as the binder will almost invariably find it necessary to cut off more paper from the foot than from the head, the make-up must make sufficient allowance for this extra trim.

When the pages have running heads one-third or less shorter than the width of the page, one-half of the space occupied by the running head should be thrown into the head margin, because the white around the running head is to be considered as part of the head margin. If a folio only is used over a page, the head margin is to be calculated from the top line of the page.

The make-up must know whether a book is to be wire-stitched through the back or sewed through the fold. If wire-stitched through the back, an extra allowance *additional* to the back margin required must be made a little in excess of the space used by the wire. This space varies according to thickness of the book, but is rarely less than three-sixteenths of an inch on *each side* of the back margin, or three-eighths of an inch in the back gutters.

In forms of 32 pages or more it is advisable, where it is possible, to impose the pages so that the sheet may be cut and folded in signatures of half the number of pages, especially when the paper is heavy; but if the form is imposed to fold as one complete signature then it is advisable to deduct enough from the back margin of the inner sections to equal the extra space taken up by the fold of the outside sections.

In imposing forms of 12 or 24 pages, great care must be taken to get the foot and head margins of the inset to be folded in exactly right, and the head and foot margins in such forms should be as evenly divided as possible. More accurate register is obtained when the inset is cut off and folded separately.

TESTING MARGINS.

After the proper head and back margins have been decided on, and the pages arranged to conform to them, the form should be tested to ascertain if the foot and front margins are correct. The method is illustrated in the accompanying diagram of a section of a 16-page form. Fold a sheet to quarter of the size of the untrimmed paper to be used. The distance from the foot of page 16 to the foot of page 10 must agree with the length of the quarter sheet (as indicated by the dotted line), and the distance from the back edge of page 7 to the back edge of page 11 must correspond with the width of the quarter sheet. This test can be made just as well by using a measuring rule or tape, in which case, if the quarter sheet were twelve inches wide by eighteen inches long, the distance from the front edge of page 12 to the front edge of page 8 must be exactly twelve inches, and the distance from the foot of page 7 to the foot of page 1 must be exactly eighteen inches.

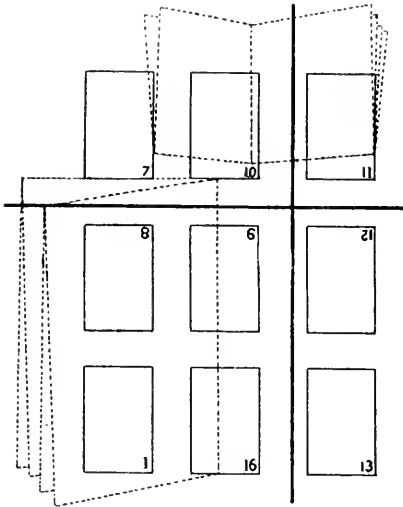

GRIPPER MARGINS.

As applied to book forms, the space between the type and the outer edge of the chase at the gripper side is the gripper margin. A gauge showing the gripper margin of each press should be obtained from the pressman. When the paper is placed in its correct position on the type form the distance between the edge of the paper and the edge of chase should be at least half an inch less than the gripper margin, to permit the pressman to move his form into a suitable place. To make a proper allowance for gripper margin, it is often necessary to place more furniture in the foot margins on the side of the long cross-bar next the gripper than on the other side. The lowest folio of a form should be placed next the gripper edge.

CORRECT IMPOSITION OF LENGTHWISE CUTS AND TABLES.

The correct rule is that lengthwise tables and cuts shall always read from the foot of page. When a lengthwise cut or table is on one page and the explanatory or descriptive matter on the opposite page, then the cut or table should, if possible, be placed on the page with the even folio.

TESTS OF CORRECT IMPOSITION.

As a general rule, except where for convenience in folding, certain forms are imposed from the center, the lowest (first) folio of a form is placed on the lower left-hand corner. All odd folios are always at the left-hand of the make-up, as viewed from the foot.

The odd and even folios of pages which are side by side in a correctly imposed regular form will, when added together, form a total of one more than the number of pages in a signature. The first and last pages of a signature are always placed side by side—as, for instance, in a 16-page form, where folios 1 and 16 equal seventeen.

PRESS POINTS.

These are used in forms that are imposed for books, the sections of which are folded by machines. In 16-page forms these points are usually placed exactly 15 inches apart—7½ inches each way from the center of the first fold. The sheets are fed into the folding machine by the point holes to insure register, and the points should be placed exactly in accordance with the instructions of the bookbinder.

EIGHTS, IN TWO FORMS.

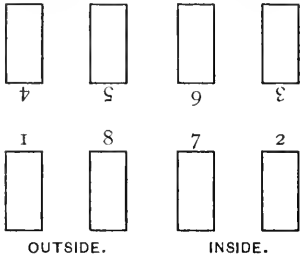

THIRTY-TWO PAGES IN TWO FORMS.

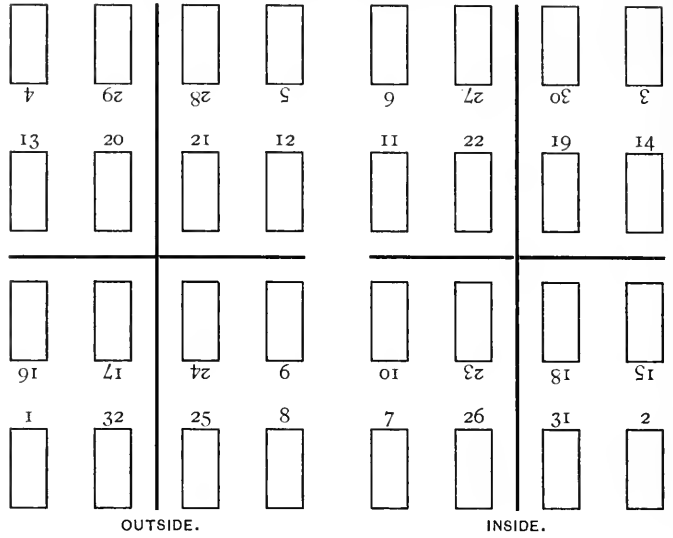

EIGHTS, WORK AND TURN.

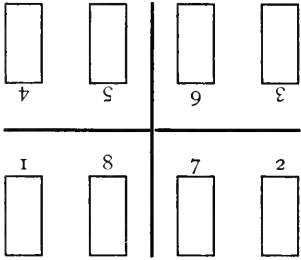

TWENTY-FOUR PAGES, IN TWO FORMS.

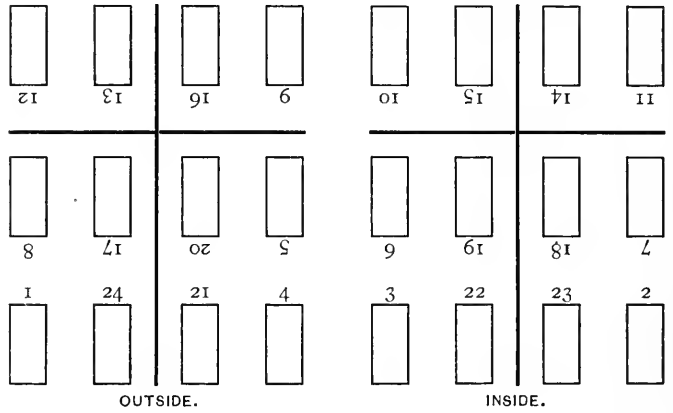

TWELVE, WITHOUT CUTTING.

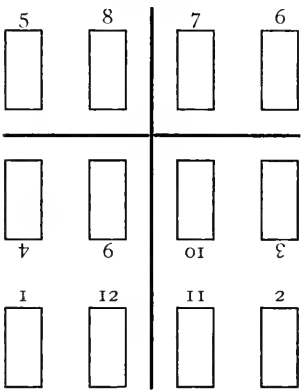

SIXTEEN PAGES, IN TWO FORMS.

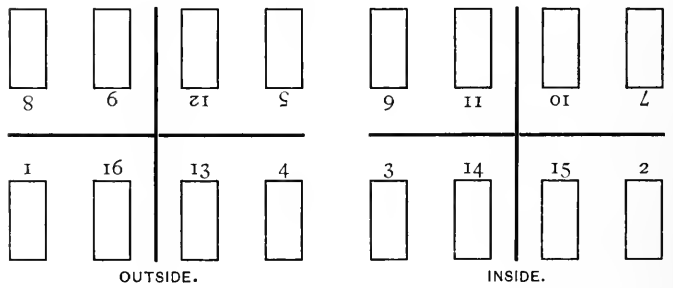

SIXTEEN, WORK AND TURN.

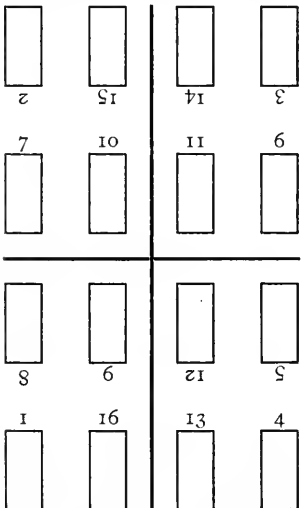

BROAD EIGHTS. IN TWO FORMS.

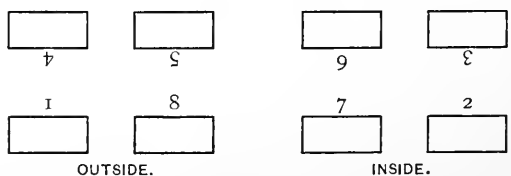

SIXTEEN PAGES, DEEP WAY.

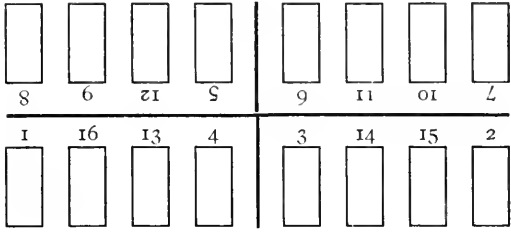

TWELVE PAGES, BROAD WAY.

In this form pages 3, 4, 9 and 10 are folded in. May frequently be used to advantage on booklets and catalogues.

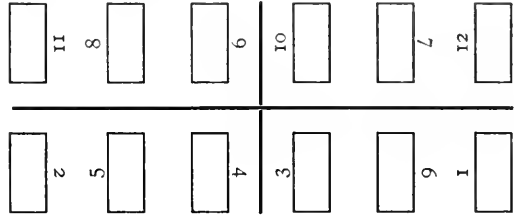

SIXTEEN PAGES, DEEP WAY.

For booklets. Paper should be trimmed before printing.

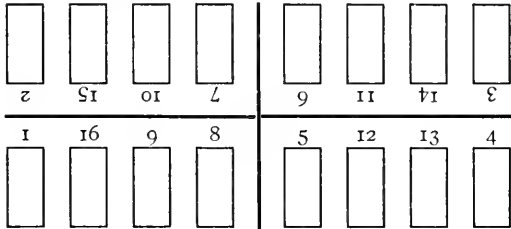

TWELVE PAGES, DEEP WAY.

This method is convenient only for deep pages, such as an odd-sized booklet, and the same size of paper used on the two regular forms for twelve pages may be used. Paper should be trimmed.

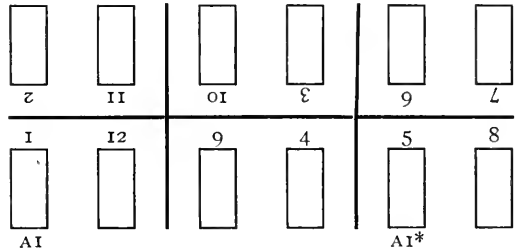

SIXTEEN PAGES, BROAD WAY, IN TWO FORMS.

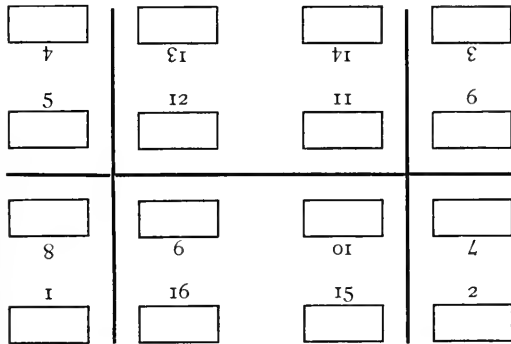

TWELVE PAGES, WITH OFF-CUT.

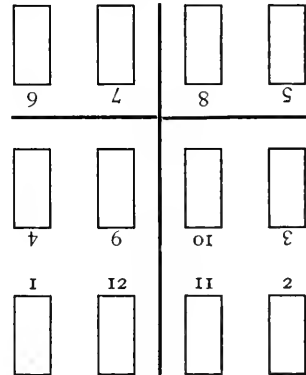

EIGHTEEN PAGES.

When the first side is worked off, transpose pages 11 and 8 in place of 7 and 12, and 7 and 12 in place of 11 and 8.

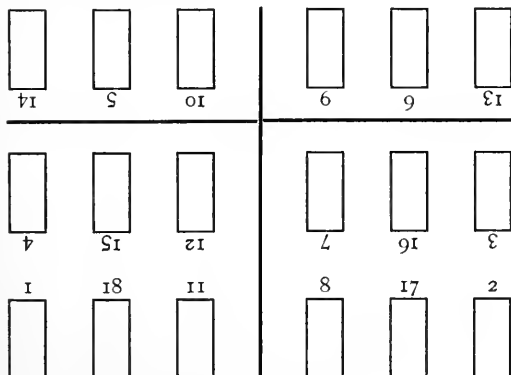

EIGHTEEN PAGES, WITHOUT TRANSPOSITION.

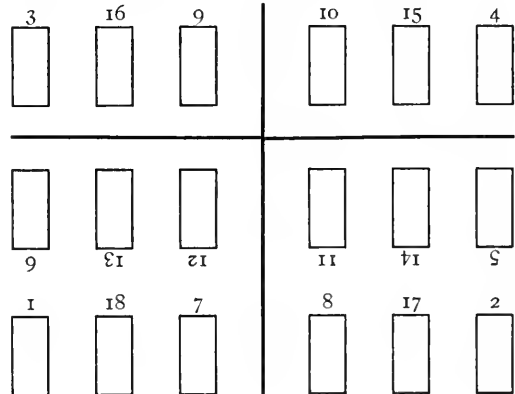

IMPOSITION OF FOLDERS.

The margins of folders are usually equal all around each page, and consequently accuracy in make-up and imposition is necessary. When the sheet is to be backed, turn it the broad way, toward the folio 2. Before printing, paper should be trimmed.

SIXTEEN-PAGE FOLDER.

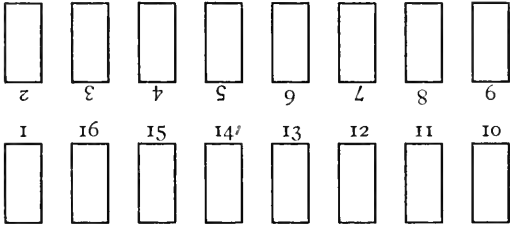

TWELVE-PAGE FOLDER.

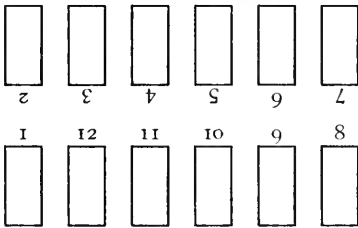

SIX-PAGE FOLDER.

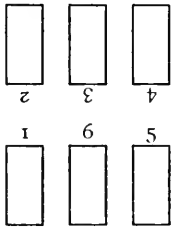

EIGHT-PAGE FOLDER.

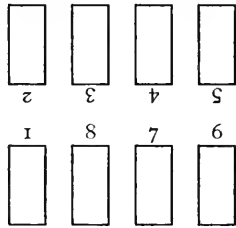

FORMS IMPOSED FROM THE CENTER.

This method of imposition is preferable in forms containing title page, copyright notice and other introductory pages with very little matter in them, as it brings the full pages outside, where they serve as bearers and often prevent slurring.

SIXTEEN PAGES, IMPOSED FROM CENTER.

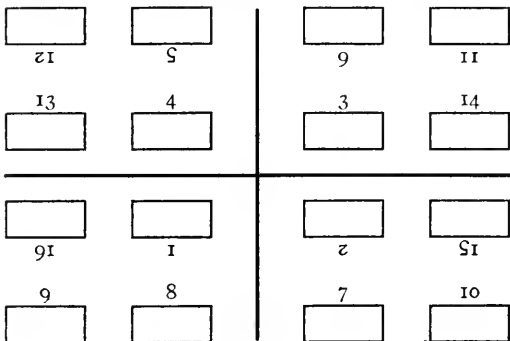

EIGHT PAGES, IMPOSED FROM CENTER.

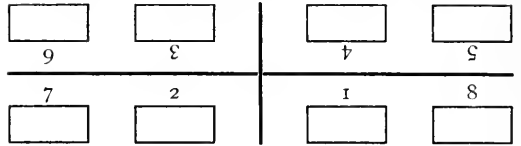

TWENTY-FOUR PAGES, IMPOSED FROM THE CENTER, IN TWO FORMS.

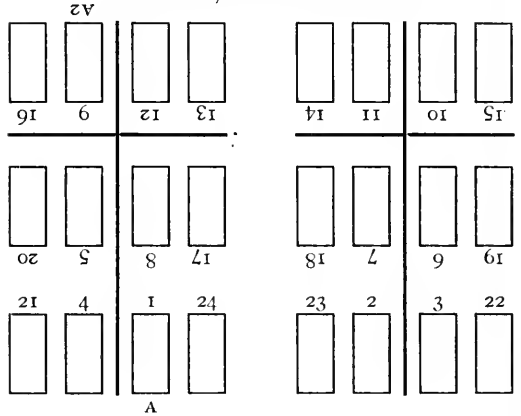

SIXTEEN PAGES, IMPOSED FROM CENTER.

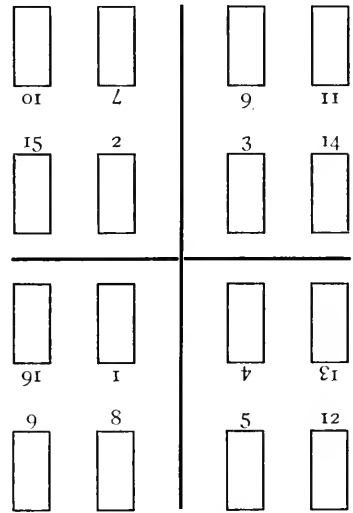

TWELVE PAGES, IMPOSED FROM CENTER.

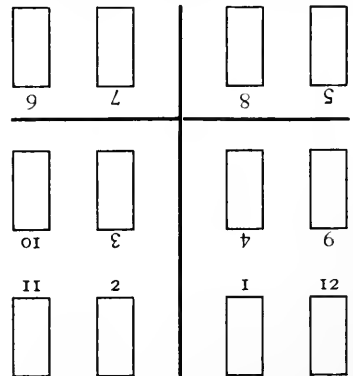

TWENTY PAGES.

Printed on double demy or double royal. This method makes a square page, suitable for booklets, where oddity is looked for.

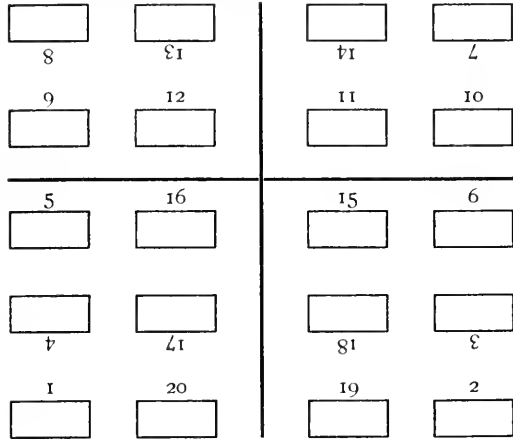

**EIGHTEEN PAGES,
TWO OF WHICH ARE BLANK.**

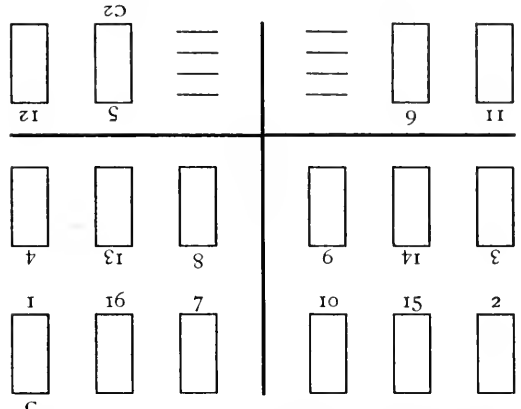

When the first side is worked off, transpose pages 7 and 10 in place of 9 and 8, and pages 9 and 8 in place of 7 and 10.

TWENTY-FOUR PAGES, DEEP WAY.

A very satisfactory form, in common use for pamphlets. Careful division of the margins is necessary, the pressman allotting the exact margin to the edge of the sheet to be folded in. Points placed as shown will assist the binder, and should be removed before backing the sheet.

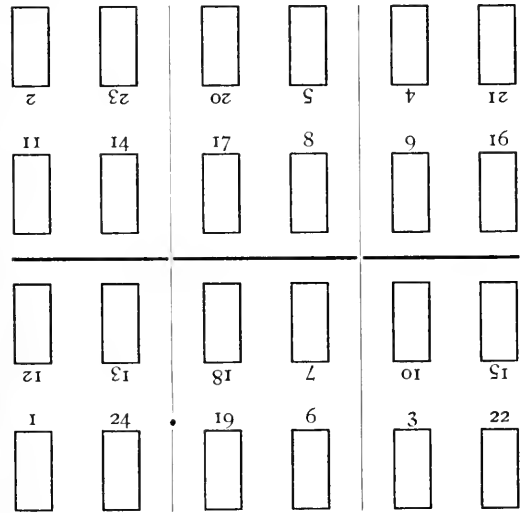

TWENTY-FOUR PAGES, WITHOUT CUTTING.

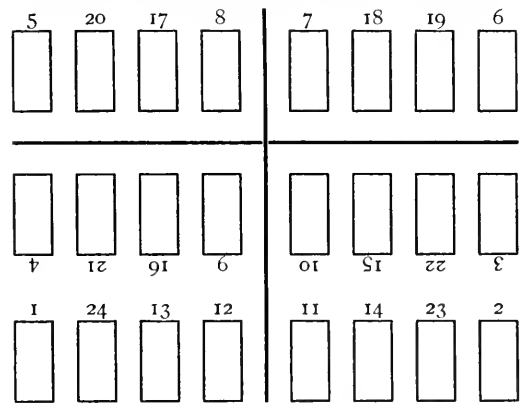

TWENTY-FOUR PAGES, BROAD WAY

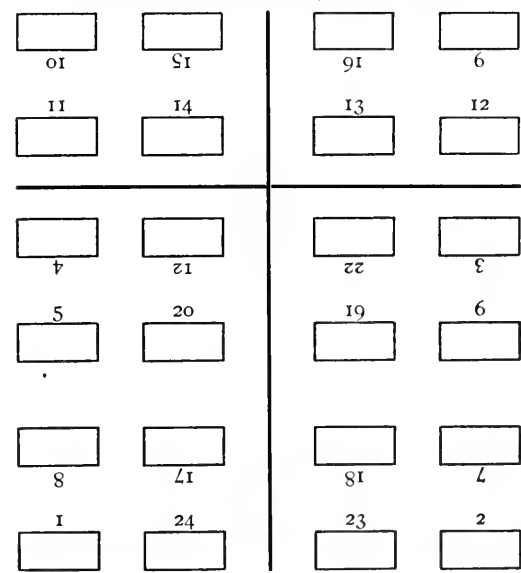

TWENTY-FOUR PAGES, WITHOUT INSET.

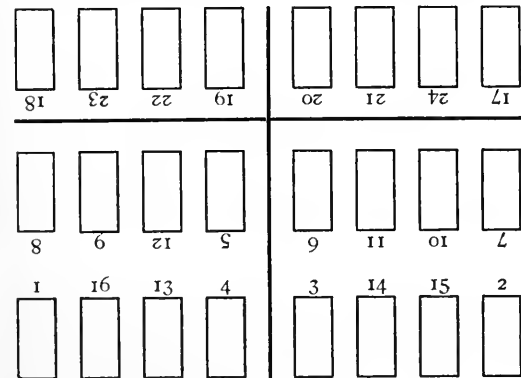

FORTY PAGES, WITH TWO SIGNATURES.

The larger signature folds same as a 32-page form. The smaller signature is an inset.

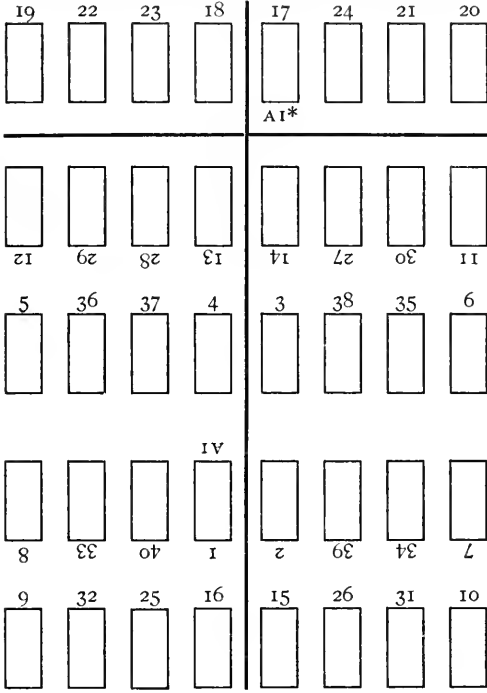

FORTY PAGES, ONE SIGNATURE.

The paper must be trimmed at ends before printing. A point should be placed where shown, about $\frac{1}{32}$ inch from the fold, encroaching on main section of form—the pressman to deduct this space from the edge of sheet, which is folded toward the form. The division of margin must be accurate, especially at head and foot of pages.

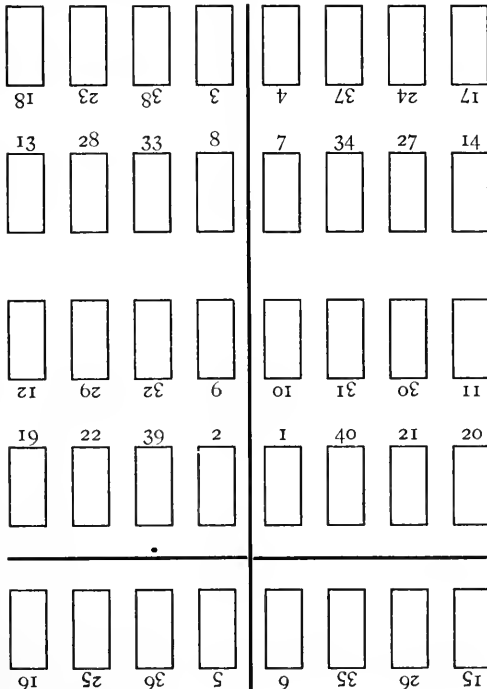

FORTY PAGES, WITH TWO SIGNATURES.

In this form there is an outset of pages, 1, 2, 3, 4, 37, 38, 39, 40, instead of an inset.

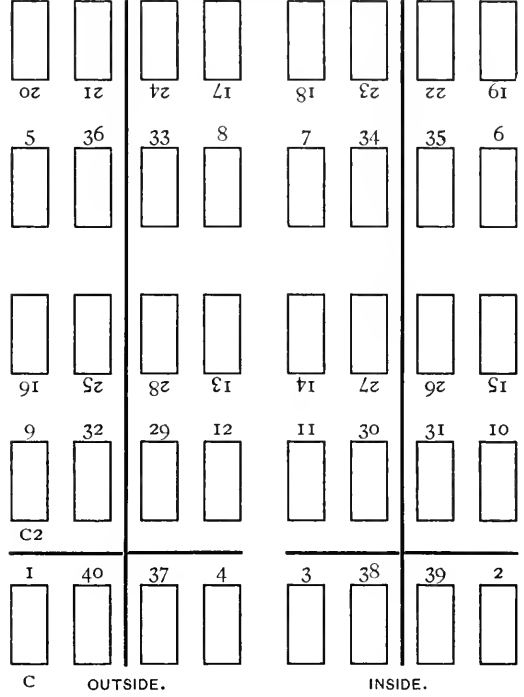

FORTY-EIGHT PAGES, WITH TWO SIGNATURES.

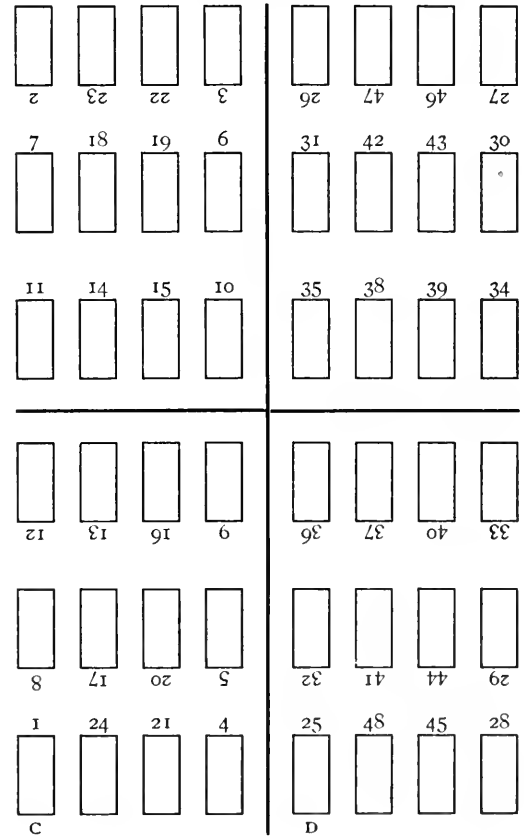

FORTY-EIGHT PAGES, WITH THREE SIGNATURES.

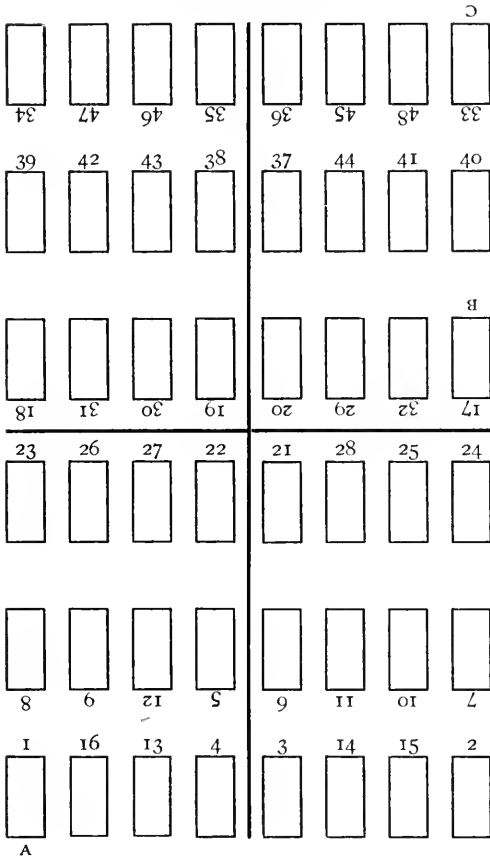

SIXTY-FOUR PAGES IN ONE SIGNATURE.

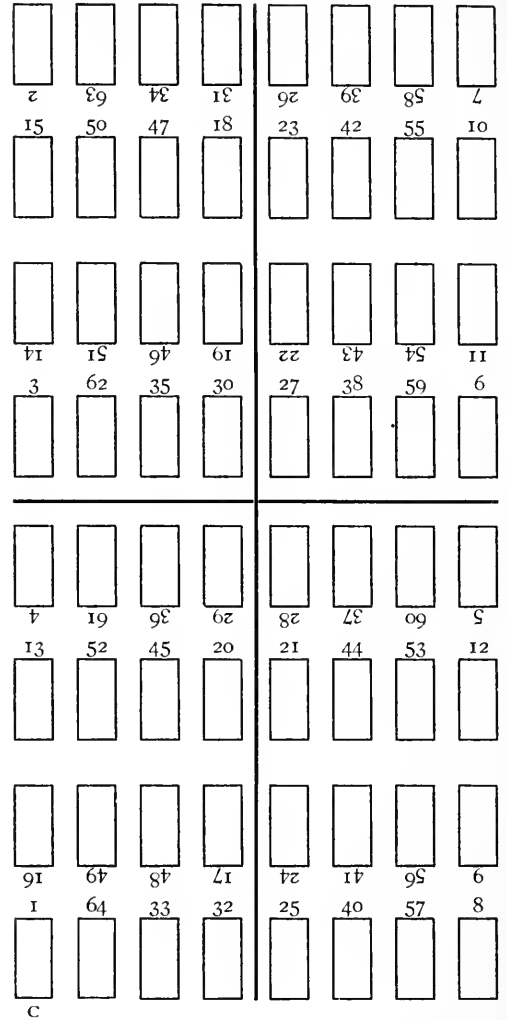

SIXTEEN PAGES, FOR HEBREW WORK, IN TWO FORMS.

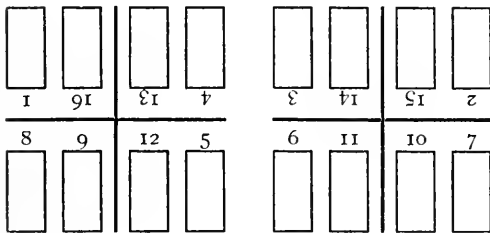

SIXTEEN PAGES, TWELVE OF ONE JOB AND FOUR OF ANOTHER, IN TWO FORMS.

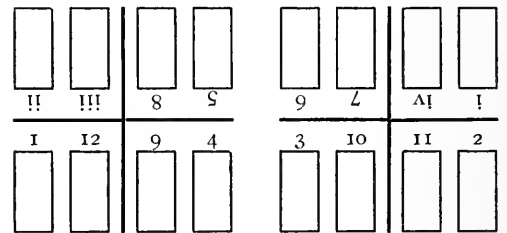

PRICE LIST OF PRINTING AND BINDING: A GUIDE FOR CHARGING.

Compiled by DAVID RAMALEY, St. Paul, Minn.

Copyrighted by David Ramaley, 1896.

The object of this publication is to unify prices, and to form a basis for agreements among printers in figuring on competitive work. The prices given are supposed to be fifty per cent. above the actual labor and material cost of the work, with ordinary conditions. The variable factor of general expense is only figured in the labor expense, because the paper or other stock used has a special expense of cutting and counting and handling equal to the proportion of general expense charge. *Twenty per cent. off from these prices will not leave twenty per cent. profit in all cases*, because sharp competition has forced down the prices of many kinds of commercial printing. A discount of twenty per cent. from the prices, in a general way, is supposed to leave twenty per cent. profit, but the factor of general expense must be considered.

INDEX TO RAMALEY'S PRICE LIST.

| | PAGE | | PAGE |
|--|------------|---|------------|
| Abstracts of title | 1122 | Delegate or nomination tickets | 1123 |
| Advertising matter | 1118, 1122 | Deposit books, bankers | 1137 |
| Advertising programmes | 1122 | Deposit tickets | 1135 |
| Alterations | 1118 | Drafts | 1135 |
| Announcements, printed or engraved | 1128, 1129 | Dodgers, hand bills and programmes | 1123 |
| Ball and dance programmes | 1129 | Engraved cards, invitations | 1128 |
| Bank printing | 1135-1137 | Envelopes, sizes of | 1121 |
| Basis for figuring value of paper | 1120 | Envelopes, tag, clasp, and stamped | 1133, 1134 |
| Beer, milk or restaurant tickets | 1132 | Guard or plat books | 1142 |
| Bill heads and monthly statements | 1130, 1131 | Hand bills or cheap circulars | 1123 |
| Bills of fare | 1132 | Hotel registers | 1134 |
| Binding, blank books | 1142 | Invitations, social and wedding | 1128 |
| Binding, books, magazines and newspapers | 1144 | Letter heads | 1131 |
| Binding, job work | 1143 | Note heads and memorandums | 1132 |
| Binding, pamphlets | 1143 | Numbering and perforating | 1142 |
| Blank books with stubs | 1140, 1141 | Paper, sizes of | 1121 |
| Blank books | 1137-1140 | Paper, value of | 1120 |
| Blanks, ruled and printed | 1136 | Perforating and numbering | 1142 |
| Blotting pads | 1129 | Postal cards and stamped envelopes | 1134 |
| Bonds and coupons | 1136 | Posters and show bills | 1123, 1129 |
| Booklets | 1122 | Presswork | 1119 |
| Briefs and paper books | 1123 | Programmes, dance and entertainment | 1129 |
| Bronze work | 1119 | Restaurant bills-of-fare | 1132 |
| By-laws, Constitutions, &c. | 1122 | Ruling on blank forms | 1142 |
| Card scale | 1126, 1127 | Shipping tags | 1134 |
| Cards, business | 1127, 1128 | Sizes of flat writing paper | 1121 |
| Cards, large or show | 1129 | Sizes of ruled paper | 1121 |
| Checks in book | 1135 | Sizes of untrimmed leaf | 1121 |
| Circulars, half note | 1125 | Stamped envelopes | 1134 |
| Circulars, folded letter (1 to 4 pages) | 1125 | Standing type | 1118 |
| Circulars, folded note (1 to 4 pages) | 1124 | Statements, monthly | 1130, 1131 |
| Circulars, half-letter or quarter-folio | 1124 | Tags | 1134 |
| Commission sales accounts | 1142 | Time work | 1118 |
| Composition | 1118, 1119 | Value of paper | 1120 |
| Constitutions | 1122 | Visiting and wedding cards | 1128 |
| Debit and credit slips | 1135 | Wedding stationery | 1128 |

SAFE BASIS ON WHICH TO DO A PROFITABLE BUSINESS.

[Adapted from the Code of Ethics of the United Typothetæ of America.]

The expense of doing business, such as the wear and tear of material, interest on money invested, bad debts, rents, taxes, insurance, book-keeping, and all other items of expense, should be ever before our eyes, and we should never forget that these must be as surely levied on each particular job as its labor costs.

Always have the courage to ask for a fair remuneration for any work offered, resting assured that it will be more profitable to be without a job than to secure one in which there is a temptation to resort to questionable methods in order to avoid a financial loss in its execution.

A master printer should always contend that he is entitled, when asked for an estimate, to know the names of all who are to be requested to bid on the work. He should also insist upon his right, if he desires it, to know all the prices offered for the work and to whom and at what price it was awarded.

A master printer should not make estimates for work that he cannot do. It is always unsafe and often unjust to give prices upon a class of work upon which the cost is not positively known and has to be guessed at.

Estimates calling for detailed specifications of separate value of the paper, composition, electrotyping, presswork, ruling, binding, etc., should always be refused.

EXPLANATORY.

The prices under the several divisions of each list, such as "100," "250," "1000," include all regular charges for labor and material to the customer unless otherwise stated, and when there is a variable factor in such prices the amount estimated for such variable factor is quoted, so that the printer can readily adjust the price in accordance with the conditions governing the work. For instance, on page 1122, in Advertising Programmes, the variable factor is composition. The price for 100 4-page Advertising Programmes on 22x32 quarto print paper is \$18.25, on the basis of 8-point composition, in which amount is *included* a charge of \$17.20, for composition at \$4.30 per page. Now, if composition should be based on 10 Point, *deduct* the difference in cost, and if on 6 Point, *add* the difference. In other instances the variable factor is the cost of paper.

We figure composition at 70c. per 1000 in all work, including locking up or making up, and at 60c. per hour for time work.

Paper is included in these prices at an average advance of 50 per cent. on cost, unless otherwise stated; but this includes storage, handling, wastage and cutting—items that are never paid for if the printer only adds 10 or 15 per cent. to cost of paper.

COMPOSITION.

To be figured at 70c. per 1000 ems, and time work 60c. an hour.

Alterations to be figured separately from composition, and charged at the hour rate.

Open Advertising Matter on newspapers or programmes to be measured as 8 Point.

Standing Type, 1c. per square inch per month.

COMPOSITION VALUES ON MISCELLANEOUS FORMS.

| | 4 TO SHEET CAP 33 SQ. IN. | 4 TO SHEET FOLIO 60 SQ. IN. | 4 TO SHEET ROYAL 70 SQ. IN. |
|--------------------------------------|------------------------------|--------------------------------|--------------------------------|
| Open blanks | \$0.75 | \$1.00 | \$1.25 |
| Open blanks and down rules | 1.20 | 2.00 | 2.50 |
| Labels, open | 1.20 | 2.15 | 2.50 |
| Six Point | 3.30 | 5.80 | 7.00 |
| Eight Point | 1.85 | 3.30 | 4.00 |
| Ten Point | 1.20 | 2.15 | 2.50 |
| Twelve Point | .85 | 1.50 | 1.75 |

COMPOSITION VALUES—Continued.

| | 8 TO SHEET CAP 15 SQ. IN. | 8 TO SHEET FOLIO 25 SQ. IN. | 8 TO SHEET ROYAL 32 SQ. IN. |
|--------------------------------------|------------------------------|--------------------------------|--------------------------------|
| Open blanks | \$0.60 | \$0.75 | \$1.00 |
| Open blanks and down rules | 1.00 | 1.50 | 1.80 |
| Labels, open | 1.00 | 1.50 | 1.80 |
| Six Point | 1.50 | 2.50 | 3.20 |
| Eight Point | 1.00 | 1.50 | 1.80 |
| Ten Point | .70 | 1.00 | 1.20 |
| Twelve Point | .50 | .75 | .85 |

| | 12 TO SHEET CAP 10 SQ. IN. | 12 TO SHEET FOLIO 20 SQ. IN. | 12 TO SHEET ROYAL 25 SQ. IN. |
|--------------------------------------|-------------------------------|---------------------------------|---------------------------------|
| Open blanks | \$0.50 | \$0.75 | \$0.75 |
| Open blanks and down rules | .75 | 1.20 | 1.50 |
| Labels | .75 | 1.20 | 1.50 |
| Six Point | 1.00 | 2.00 | 2.50 |
| Eight Point | .75 | 1.20 | 1.50 |
| Ten Point | .50 | .75 | 1.00 |
| Twelve Point | .50 | .60 | .70 |

| | 16 TO SHEET CAP 12 SQ. IN. | 16 TO SHEET FOLIO 18 SQ. IN. | 16 TO SHEET ROYAL 22 SQ. IN. |
|--------------------------------------|-------------------------------|---------------------------------|---------------------------------|
| Open blanks | \$0.50 | \$0.75 | \$0.75 |
| Open blanks and down rules | .75 | 1.00 | 1.25 |
| Labels | .75 | 1.00 | 1.25 |
| Six Point | 1.30 | 1.60 | 2.25 |
| Eight Point | .75 | 1.00 | 1.25 |
| Ten Point | .50 | .65 | .85 |
| Twelve Point | .50 | .60 | .70 |

Compare figures with time ; estimates to include lock-up.

PRESSWORK.

The value of presswork is a difficult problem, because there are so many different grades of work. The prices in the following tables represent the value of good work. Since the introduction of plated papers and half-tone work rates may not be large enough for the best service, but on the average of work in an office the figures ought to be considered as fair and reasonable.

Flat papers.

| | 100 | 250 | 500 | 1000 | ADDED 100 |
|------------------------------------|--------|--------|--------|--------|-----------|
| Double medium | \$1.75 | \$2.10 | \$2.60 | \$3.50 | \$0.18 |
| Double cap | 1.50 | 1.75 | 2.10 | 2.85 | .13 |
| Folio post | 1.00 | 1.30 | 1.60 | 2.35 | .13 |
| Flat cap | 1.00 | 1.30 | 1.60 | 2.35 | .13 |
| Half folio | 1.00 | 1.30 | 1.60 | 2.35 | .13 |
| Half cap | .75 | .90 | 1.15 | 1.65 | .08 |
| Quarter folio, long form | 1.00 | 1.30 | 1.60 | 2.35 | .13 |
| Quarter folio, regular | .75 | .90 | 1.15 | 1.65 | .08 |
| Quarter cap | .75 | .90 | 1.15 | 1.65 | .08 |
| Smaller sizes | .60 | .75 | .90 | 1.30 | .06 |

Print and cheap book.

| | 100 | 250 | 500 | 1000 | ADDED 100 |
|---------------------------------------|------|------|------|------|-----------|
| 38 x 50 | 2.00 | 2.50 | 3.00 | 4.50 | .28 |
| 36 x 48 | 2.00 | 2.50 | 3.00 | 4.25 | .26 |
| 32 x 44 | 2.00 | 2.50 | 3.00 | 4.00 | .24 |
| 28 x 42 | 2.00 | 2.50 | 3.00 | 3.50 | .22 |
| 25 x 38 | 1.75 | 2.25 | 2.75 | 3.00 | .18 |
| 22 x 32 | 1.75 | 2.25 | 2.75 | 3.00 | .15 |
| Medium and folios | 1.00 | 1.30 | 1.60 | 2.35 | .13 |
| Half folio and caps | 1.00 | 1.30 | 1.60 | 2.35 | .10 |
| Half cap and quarter folios | .75 | .90 | 1.15 | 1.65 | .08 |

Book-work.

| | 100 | 250 | 500 | 1000 | ADDED 100 |
|-------------------|------|------|------|------|-----------|
| 38 x 50 | 2.50 | 3.00 | 3.75 | 5.00 | .30 |
| 36 x 48 | 2.50 | 3.00 | 3.75 | 4.75 | .28 |
| 32 x 44 | 2.50 | 3.00 | 3.50 | 4.50 | .25 |
| 28 x 42 | 2.50 | 3.00 | 3.50 | 4.00 | .23 |
| 25 x 38 | 2.00 | 2.50 | 3.00 | 3.50 | .20 |
| 22 x 32 | 2.00 | 2.40 | 2.75 | 3.25 | .17 |
| 19 x 25 | 1.50 | 2.00 | 2.50 | 3.00 | .14 |

Half-tone work on highly-finished or plated papers add 25 per cent. to book-work scale.

Bronze work, double presswork.

BASIS FOR FIGURING VALUE OF PAPER.

The basis for figuring the value of paper will be 50 per cent. on the cost price. This price is to include the proportionate cost of general expense and handling in every way—the opening, cutting, and repacking and waste.

Unless there is a special determination by the customer as to the quality of papers, figures will be based on grades of book and writing papers as follows:

| | | | |
|--|----|---|----|
| Print paper, 2¾c., to be figured at | 4½ | Tub sized, 11c., to be figured at | 18 |
| Colored print, 4c., to be figured at | 6 | Water marked, 13c., to be figured at | 20 |
| Common book, 4c., to be figured at | 6 | Linen, 14c., to be figured at | 21 |
| S. & C. book, 4½c., to be figured at | 7 | Fine linen, 16c., to be figured at | 24 |
| S. & S. C. book, 5c., to be figured at | 7½ | Superfine linen, 18c., to be figured at | 27 |
| Plated book, 8c., to be figured at | 12 | Pure linen, 21c., to be figured at | 30 |
| Manilla, 4¾c., to be figured at | 6½ | Crane's linens, 24c., to be figured at | 35 |
| Engine sized, 7c., to be figured at | 11 | | |

PRINTERS' VALUE OF 1000 SHEETS PAPER OF THE WEIGHT DESIGNATED AT TOP OF COLUMN.

The basis for figuring the value of paper is 50 per cent. on the cost price.

| | 12-LB. | 14-LB. | 16-LB. | 18-LB. | 20-LB. | 22-LB. |
|--------------------------------|--------|--------|--------|--------|--------|--------|
| Costing \$0.02 per lb. | \$0.75 | \$0.87 | \$1.00 | \$1.13 | \$1.25 | \$1.38 |
| Costing .02½ per lb. | .94 | 1.09 | 1.25 | 1.41 | 1.57 | 1.73 |
| Costing .03 per lb. | 1.13 | 1.32 | 1.50 | 1.69 | 1.88 | 2.07 |
| Costing .03½ per lb. | 1.32 | 1.54 | 1.75 | 1.97 | 2.19 | 2.42 |
| Costing .04 per lb. | 1.50 | 1.75 | 2.00 | 2.25 | 2.50 | 2.75 |
| Costing .05 per lb. | 1.88 | 2.18 | 2.50 | 2.82 | 3.13 | 3.45 |
| Costing .05½ per lb. | 2.06 | 2.41 | 2.75 | 3.10 | 3.44 | 3.78 |
| Costing .06 per lb. | 2.25 | 2.63 | 3.00 | 3.38 | 3.75 | 4.13 |
| Costing .06½ per lb. | 2.44 | 2.85 | 3.25 | 3.66 | 4.07 | 4.47 |
| Costing .07 per lb. | 2.63 | 3.07 | 3.50 | 3.94 | 4.38 | 4.81 |
| Costing .07½ per lb. | 2.81 | 3.27 | 3.75 | 4.22 | 4.69 | 5.18 |
| Costing .08 per lb. | 3.00 | 3.50 | 4.00 | 4.50 | 5.00 | 5.50 |
| Costing .08½ per lb. | 3.19 | 3.72 | 4.25 | 4.78 | 5.31 | 5.84 |
| Costing .09 per lb. | 3.38 | 3.94 | 4.50 | 5.06 | 5.63 | 6.19 |
| Costing .09½ per lb. | 3.56 | 4.15 | 4.75 | 5.34 | 5.94 | 6.53 |
| Costing .10 per lb. | 3.75 | 4.35 | 5.00 | 5.63 | 6.25 | 6.90 |
| Costing .10½ per lb. | 3.94 | 4.60 | 5.25 | 5.90 | 6.57 | 7.22 |
| Costing .11 per lb. | 4.12 | 4.81 | 5.50 | 6.19 | 6.88 | 7.56 |
| Costing .11½ per lb. | 4.32 | 5.04 | 5.75 | 6.48 | 7.20 | 7.92 |
| Costing .12 per lb. | 4.50 | 5.25 | 6.00 | 6.75 | 7.50 | 8.25 |
| Costing .12½ per lb. | 4.68 | 5.46 | 6.25 | 7.02 | 7.80 | 8.58 |
| Costing .13 per lb. | 4.88 | 5.70 | 6.50 | 7.32 | 8.13 | 8.94 |
| Costing .14 per lb. | 5.25 | 6.13 | 7.00 | 7.88 | 8.75 | 9.62 |
| Costing .15 per lb. | 5.62 | 6.53 | 7.50 | 8.44 | 9.38 | 10.35 |
| Costing .16 per lb. | 6.00 | 7.00 | 8.00 | 9.00 | 10.00 | 11.00 |
| Costing .17 per lb. | 6.38 | 7.44 | 8.50 | 9.56 | 10.62 | 11.68 |
| Costing .18 per lb. | 6.75 | 7.88 | 9.00 | 10.12 | 11.25 | 12.38 |
| Costing .19 per lb. | 7.12 | 8.30 | 9.50 | 10.68 | 11.88 | 13.06 |
| Costing .20 per lb. | 7.50 | 8.70 | 10.00 | 11.25 | 12.50 | 13.80 |
| Costing .21 per lb. | 7.88 | 9.20 | 10.50 | 11.80 | 13.14 | 14.44 |
| Costing .22 per lb. | 8.24 | 9.62 | 11.00 | 12.38 | 13.75 | 15.12 |
| Costing .23 per lb. | 8.64 | 10.08 | 11.50 | 12.96 | 14.40 | 15.84 |
| Costing .24 per lb. | 9.00 | 10.50 | 12.00 | 13.50 | 15.00 | 16.50 |
| Costing .25 per lb. | 9.36 | 10.92 | 12.50 | 14.04 | 15.60 | 17.16 |

For other weights combine or divide the figures.

American linen and similar grades: 14-lb., \$9.80; 16-lb., \$11.20; 18-lb., \$12.60; 20-lb., \$14.00.

Crane Bros'. all linen and similar goods, 500 sheets to ream: 16-lb., \$11.20; 20-lb., \$14.00; 24-lb., \$16.80.

Japanese linen and similar goods, 480 sheets to ream: 20-lb., \$14.00; 24-lb., \$17.30; 28-lb., \$18.80.

Ledger papers, per 100 sheets (Weston or Brown).

- Demy, 28-lb., \$2.15; 30-lb., \$2.40.
- Medium, 36-lb., \$3.00; 40-lb., \$3.50.
- Double cap, 36-lb., \$2.50; 40-lb., \$2.80.
- Royal, 44-lb., \$3.70. Super royal, 54-lb., \$5.00.
- Double demy, 56-lb., \$4.25.
- Double medium, 72-lb., \$6.00; 80-lb., \$7.00.

SIZES OF FLAT WRITING PAPER.

| | | | |
|--|---------|---------------------------------|---------|
| Flat Letter | 10 × 16 | Double Demy, narrow | 16 × 42 |
| Flat Packet or Packet Post | 12 × 19 | Double Demy, broad | 21 × 32 |
| Flat Foolscap or Small Cap | 13 × 16 | Elephant | 23 × 28 |
| Flat Cap | 14 × 17 | Medium | 18 × 23 |
| Crown or Crown Cap | 15 × 19 | Imperial | 23 × 31 |
| Double Letter | 16 × 20 | Double Medium, narrow | 18 × 46 |
| Demy | 16 × 21 | Double Medium, broad | 23 × 36 |
| Folio Post or Folio | 17 × 22 | Double Royal | 24 × 38 |
| Double Folio | 22 × 34 | Double Elephant | 27 × 40 |
| Double Cap | 17 × 28 | Columbier | 23 × 34 |
| Small Double Cap | 16 × 26 | Atlas | 26 × 33 |
| Royal, Double Packet or Packet Folio | 19 × 24 | Antiquarian | 31 × 53 |
| Super Royal | 20 × 28 | Cardboard | 22 × 28 |

SIZES OF RULED PAPER.

| | INCHES. | SHEET. | | INCHES. | SHEET. |
|-----------------------------------|---------|----------|------------------------------------|---------|----------|
| Commercial Note Heads | 5½ × 8½ | ⅓ Folio | Bill Heads — Thirds, 1500 to | | |
| Hotel Note Heads | 5¾ × 11 | ⅓ Folio | Ream | 8½ × 9½ | ⅓ D. Cap |
| Packet Note Heads | 5¾ × 9 | ⅓ Medium | Bill Heads — Halves, 1000 to | | |
| Royal Packet Note Heads | 6 × 9½ | ⅓ Royal | Ream | 8½ × 14 | ⅓ Cap |
| Demy Letter Heads | 8 × 10½ | ⅓ Demy | Regular Statements | 5½ × 8½ | ⅓ Folio |
| Folio Letter Heads | 8½ × 11 | ⅓ Folio | Hotel Statements | 5½ × 11 | ⅓ Folio |
| Memorandum Heads | 5½ × 8½ | ⅓ Folio | Head and Tail Statements | 5½ × 8½ | ⅓ Folio |
| Bill Heads — Sixes, 3000 to | | | Gem Statements | 3¾ × 5¾ | |
| Ream | 8½ × 4¾ | ⅓ Cap | Infant Statements | 4¼ × 5½ | |
| Bill Heads — Quarters, 2000 | | | Square Statements | 5½ × 5¾ | |
| to Ream | 8½ × 7 | ⅓ Cap | Yankee Statements | 3¾ × 8½ | |

REGULAR ENVELOPE SIZES.

| BANK. | No. | INCHES. | PAMPHLET. | No. | INCHES. |
|--------------------|-----|----------|---------------------------------|----------|---------|
| No. 6 | 9 | 3½ × 8¾ | No. 2 | 6½ × 10 | |
| " 7 | 10 | 4¼ × 9½ | " 3 | 6¾ × 10½ | |
| " 8 | 11 | 4½ × 10¾ | | | |
| | 12 | 4¾ × 11 | PAY. | | |
| | 14 | 5 × 11½ | No. 2 | 2¼ × 4½ | |
| BARONIAL. | | | | | |
| No. 4 | | | PHOTOGRAPH. | | |
| " 5 | | | OPEN END. | | |
| | | | Cabinet | 4¼ × 7¼ | |
| COMMERCIAL. | | | Wide Imperial Cabinet | 5¾ × 7½ | |
| No. 3 | | | | | |
| " 4 | | | PORTFOLIO. | | |
| " 5 | | | No. 1 | 5½ × 8¾ | |
| " 6 | | | " 2 | 6¼ × 8¾ | |
| " 6¾ | | | " 3 | 6¼ × 9½ | |
| " 7 | | | | | |

SIZES OF THE UNTRIMMED LEAF.

| | | |
|--|----------|--------|
| Folio | 12 × 19 | inches |
| Quarto, 4to | 9½ × 12 | " |
| Imperial 8vo or 8° (octavo) | 8¼ × 11½ | " |
| Super Royal 8vo or 8° (octavo) | 7 × 11 | " |
| Royal 8vo or 8° (octavo) | 6½ × 10 | " |
| Medium 8vo or 8° (octavo) | 6 × 9½ | " |
| Demy 8vo or 8° (octavo) | 5½ × 8½ | " |
| Medium 12mo or 12° (duodecimo) | 5½ × 7¾ | " |
| Medium 16mo or 16° (sextoecimo) | 4½ × 6¾ | " |
| Cap 8vo or 8° (octavo) | 4¼ × 7 | " |
| Medium 18mo or 18° (octodecimo) | 4 × 6¾ | " |
| Super Royal 32mo (tricesimo secundo) | 3½ × 5½ | " |

ADVERTISING PROGRAMMES.

Composition on advertising programmes is properly rated as 8 Point, and if the programme itself is set in 6 Point an extra charge should be made of \$1.00.

Folding not included in following figures.

Four Pages—Quarter sheet of 22 x 32.

| | PRINT PAPER. | BOOK PAPER. |
|--|-----------------|----------------|
| 100 copies, 13 ems, 3 columns to page, composition, per page, \$4.30 | \$18.25 | \$18.30 |
| Added 100 copies | .26 | .31 |
| Added 1,000 copies | 2.50 | 3.00 |

Four Pages—Quarter sheet of 24 x 36.

| | | |
|--|-------|-------|
| 100 copies, 15 ems, 3 columns to page, composition, per page, \$5.60 | 23.50 | 23.60 |
| Added 100 copies | .27 | .32 |
| Added 1,000 copies | 2.60 | 3.10 |

Four Pages—Quarter sheet of 25 x 38.

| | | |
|--|-------|-------|
| 100 copies, 16 ems, 3 columns to page, composition, per page, \$6.10 | . . . | 25.55 |
| Added 100 copies | . . . | .35 |
| Added 1,000 copies | . . . | 3.40 |

Four Pages—Quarter sheet of 26 x 40.

| | | |
|--|-------|-----|
| 100 copies, 13 ems, 4 columns to page, composition, per page, \$7.50 | 31.20 | . . |
| Added 100 copies | .29 | . . |
| Added 1,000 copies | 2.75 | . . |

Four Pages—Quarter sheet of 28 x 42.

| | | |
|--|-------|-------|
| 100 copies, 13 ems, 4 columns to page, composition, per page, \$8.10 | 33.60 | 33.70 |
| Added 100 copies | .30 | .38 |
| Added 1,000 copies | 2.80 | 3.70 |

Half the size, at two-thirds the rate.

Advertising matter on newspapers or programmes to be measured as 8 Point.

Alterations to be figured separately from composition and charged at the hour rate of 60 cents.

BY-LAWS, CONSTITUTIONS AND SMALL BOOKLETS.

Size of printed page, 3 1/2 x 5 1/2 inches, trimmed, 32 to sheet of 22 x 32 40-lb. book paper and 50-lb. cover paper.

| | 8 POINT TYPE. | 7 POINT TYPE. | 6 POINT TYPE. |
|--|------------------|------------------|------------------|
| 8 pages (15 x 27 ems) and cover | \$ 7.75 | \$ 9.40 | \$11.65 |
| Added 100 copies | .55 | .55 | .55 |
| 500 copies | 9.95 | 11.60 | 13.85 |
| 1000 copies | 12.70 | 14.35 | 16.60 |
| Added 1000 copies | 5.50 | 5.50 | 5.50 |
| 16 pages (15 x 27 ems) and cover | 13.00 | 16.30 | 20.80 |
| Added 100 copies | .75 | .75 | .75 |
| 500 copies | 16.00 | 19.30 | 23.80 |
| 1000 copies | 19.75 | 23.05 | 27.55 |
| Added 1000 copies | 7.50 | 7.50 | 7.50 |
| 24 pages (15 x 27 ems) and cover | 19.30 | 24.25 | 31.00 |
| Added 100 copies | 1.05 | 1.05 | 1.05 |
| 32 pages (15 x 27 ems) and cover | 25.00 | 31.60 | 41.00 |
| Added 100 copies | 1.30 | 1.30 | 1.30 |

ABSTRACTS OF TITLE.

Printed on half sheet of 16-lb. flat cap, usually set in 10 Point type, hanging indention, one full page, with backing :

| | |
|--|--------|
| 100 copies (composition, \$4.00) | \$5.30 |
| Additional 100 copies | .40 |
| Additional pages, 100 copies | 4.05 |
| Added 100 copies | .40 |

Printed on ruled paper, separating descriptions, add \$1.00 for each page to above prices.

Cover and backing, add \$2.00.

BRIEFS AND PAPER BOOKS.

\$1.00 per printed page, net, for all under 100 pages; over 100 pages, 90 cents per page, net.

DODGERS, HAND-BILLS, PROGRAMMES, ETC.

ON PRINT AND BOOK PAPER.

On 3-cent paper (24×36 inches, 30-lb.).

| | 100 | 250 | 500 | 1000 | ADDED 1000 |
|---|--------|--------|--------|--------|------------|
| 3 to a sheet, paper \$0.90 per thousand | \$4.50 | \$5.00 | \$5.50 | \$6.75 | \$2.40 |
| 4 to a sheet, paper .68 per thousand | 4.00 | 4.50 | 5.00 | 6.00 | 2.10 |
| 6 to a sheet, paper .45 per thousand | 3.25 | 3.65 | 4.10 | 4.90 | 1.80 |
| 8 to a sheet, paper .34 per thousand | 2.45 | 2.75 | 3.15 | 3.80 | 1.40 |
| 10 to a sheet, paper .27 per thousand | 2.25 | 2.60 | 2.85 | 3.50 | 1.30 |
| 12 to a sheet, paper .23 per thousand | 1.90 | 2.20 | 2.50 | 3.10 | 1.20 |
| 16 to a sheet, paper .17 per thousand | 1.75 | 1.95 | 2.15 | 2.60 | .90 |
| 24 to a sheet, paper .12 per thousand | 1.20 | 1.40 | 1.55 | 2.00 | .70 |

On 4-cent paper (24×36 inches, 40-lb.).

| | | | | | |
|---|------|------|------|------|------|
| 3 to a sheet, paper \$1.60 per thousand | 4.60 | 5.20 | 5.85 | 7.00 | 3.10 |
| 4 to a sheet, paper 1.20 per thousand | 4.10 | 4.60 | 5.55 | 6.45 | 2.60 |
| 6 to a sheet, paper .80 per thousand | 3.35 | 3.70 | 4.20 | 5.35 | 2.15 |
| 8 to a sheet, paper .60 per thousand | 2.55 | 2.80 | 3.25 | 4.10 | 1.70 |
| 10 to a sheet, paper .48 per thousand | 2.35 | 2.65 | 2.95 | 3.70 | 1.50 |
| 12 to a sheet, paper .40 per thousand | 2.00 | 2.25 | 2.55 | 3.25 | 1.40 |
| 16 to a sheet, paper .30 per thousand | 1.80 | 2.00 | 2.24 | 2.75 | 1.05 |
| 24 to a sheet, paper .20 per thousand | 1.30 | 1.40 | 1.60 | 2.00 | .80 |

The 4c. paper will represent the value of colored prints.

Blue or green ink will add for the first 100 copies \$1.00, and for subsequent 100s, in sizes above sixes, 10c. per 100. On sixes and eights, subsequent 100s at 5c.

Bright red ink will add for the first 100 copies \$1.25, and for subsequent 100s, in sizes above sixes, 20c. per 100. On sixes and eights, subsequent 100s at 10c.

POSTERS AND SHOW-BILLS.

Using 40-lb. paper, 28×42 inches, costing 4c., the value of 100 sheets being 50c.

Whole sheet.

| | 100 | 250 | 500 | 1000 | ADDED 100 |
|---------------------------|--------|--------|---------|---------|-----------|
| Black ink | \$5.10 | \$6.50 | \$ 8.75 | \$13.00 | \$0.90 |
| Red or blue ink | 6.10 | 7.75 | 11.50 | 16.00 | 1.10 |
| In two colors | 7.80 | 9.90 | 13.40 | 20.40 | 1.40 |

Half sheet.

| | | | | | |
|---------------------------|------|------|-------|-------|-----|
| Black ink | 4.30 | 5.05 | 6.30 | 8.80 | .50 |
| Red or blue ink | 5.30 | 6.20 | 7.70 | 10.70 | .60 |
| In two colors | 7.00 | 8.35 | 10.60 | 15.00 | .90 |

Third sheet.

| | | | | | |
|---------------------------|------|------|------|-------|-----|
| Black ink | 3.70 | 4.25 | 5.10 | 6.85 | .35 |
| Red or blue ink | 4.70 | 5.30 | 6.30 | 8.30 | .40 |
| In two colors | 6.20 | 7.25 | 8.80 | 12.00 | .65 |

Quarter sheet.

| | | | | | |
|---------------------------|------|------|------|-------|-----|
| Black ink | 3.15 | 3.60 | 4.35 | 5.85 | .30 |
| Red or blue ink | 4.15 | 4.70 | 5.55 | 7.30 | .35 |
| In two colors | 5.50 | 6.35 | 7.75 | 10.50 | .55 |

The most effective plain posters are printed on yellow paper, the value of paper being 80c. per 100 full sheets.

On 24×36 paper the difference is so slight, except in large quantities, that the same price should prevail. In 1000 orders a discount of 10 per cent. may be made.

DELEGATE OR NOMINATION TICKETS.

For conventions in separate lots of 500.

| 500 | 1000 | 1500 | 2000 | ADDED 1000 |
|--------|--------|--------|--------|------------|
| \$1.25 | \$1.50 | \$2.00 | \$2.25 | \$1.00 |

HALF-LETTER OR QUARTER-FOLIO CIRCULARS.

No form rated at less than \$1.00. The figures in this table are based on 10 Point and \$2.00 for composition. The value of a full page of 12 Point is \$1.50; 10 Point, \$2.00; 8 Point, \$3.00; 6 Point, \$4.00. The difference should be added or deducted from the gross figures.

20-lb. stock.

| | 100 | 250 | 500 | 1000 | ADDED 100 |
|---|--------|--------|--------|--------|-----------|
| 8-cent paper, \$1.20 per thousand | \$2.85 | \$3.20 | \$3.75 | \$4.85 | \$0.20 |
| 10-cent paper, 1.50 per thousand | 2.90 | 3.30 | 3.90 | 5.15 | .23 |
| 12-cent paper, 1.80 per thousand | 2.95 | 3.35 | 4.05 | 5.45 | .26 |
| 14-cent paper, 2.10 per thousand | 2.95 | 3.40 | 4.20 | 5.75 | .29 |
| 16-cent paper, 2.40 per thousand | 3.00 | 3.50 | 4.35 | 6.05 | .32 |
| 18-cent paper, 2.70 per thousand | 3.05 | 3.55 | 4.50 | 6.35 | .35 |
| 20-cent paper, 3.00 per thousand | 3.05 | 3.65 | 4.65 | 6.65 | .38 |

24-lb. stock will add for paper for each 1000 copies—on 8c. paper 25c., 10c. paper 31c., 12c. paper 37c., 14c. paper 44c., 16c. paper 50c., 18c. paper 56c., 20c. paper 62c.

Printing front and back, different forms, add for composition and 5c. per 100 additional for presswork.

Figure on 10c. paper and 20-lb. stock, unless requested otherwise.

FOLDED NOTE CIRCULARS.

Using quarter sheet demy or folio. The figures are based on 10 Point and \$1.00 for each page of composition. The value of a full page of 12 Point is 75c.; 8 Point, \$1.50; 6 Point, \$2.00. The difference should be added or deducted from the gross figures.

One page, folded, 20-lb stock.

| | 100 | 250 | 500 | 1000 | ADDED 100 |
|---|--------|--------|--------|--------|-----------|
| 8-cent paper, \$1.20 per thousand | \$2.00 | \$2.30 | \$2.85 | \$4.00 | \$0.20 |
| 10-cent paper, 1.50 per thousand | 2.05 | 2.40 | 3.00 | 4.30 | .23 |
| 12-cent paper, 1.80 per thousand | 2.10 | 2.45 | 3.15 | 4.60 | .26 |
| 14-cent paper, 2.10 per thousand | 2.15 | 2.50 | 3.30 | 4.90 | .29 |
| 16-cent paper, 2.40 per thousand | 2.20 | 2.60 | 3.45 | 5.20 | .32 |
| 18-cent paper, 2.70 per thousand | 2.25 | 2.65 | 3.60 | 5.50 | .35 |
| 20-cent paper, 3.00 per thousand | 2.30 | 2.70 | 3.75 | 5.80 | .38 |

Two pages, folded, 20-lb. stock.

| | | | | | |
|-------------------------|------|------|------|------|-----|
| 8-cent paper | 2.00 | 3.30 | 3.85 | 5.00 | .25 |
| 10-cent paper | 3.05 | 3.40 | 4.00 | 5.30 | .28 |
| 12-cent paper | 3.10 | 3.45 | 4.15 | 5.60 | .31 |
| 14-cent paper | 3.15 | 3.50 | 4.30 | 5.90 | .34 |
| 16-cent paper | 3.20 | 3.60 | 4.45 | 6.20 | .37 |
| 18-cent paper | 3.25 | 3.65 | 4.60 | 6.50 | .40 |
| 20-cent paper | 3.30 | 3.70 | 4.75 | 6.80 | .43 |

Three pages, folded, 20-lb. stock.

| | | | | | |
|-------------------------|------|------|------|------|-----|
| 8-cent paper | 4.00 | 4.30 | 4.85 | 6.00 | .25 |
| 10-cent paper | 4.05 | 4.40 | 5.00 | 6.30 | .28 |
| 12-cent paper | 4.10 | 4.45 | 5.15 | 6.60 | .31 |
| 14-cent paper | 4.15 | 4.50 | 5.30 | 6.90 | .34 |
| 16-cent paper | 4.20 | 4.60 | 5.45 | 7.20 | .37 |
| 18-cent paper | 4.25 | 4.65 | 5.60 | 7.50 | .40 |
| 20-cent paper | 4.30 | 4.70 | 5.75 | 7.70 | .43 |

Four pages, folded, 20-lb. stock.

| | | | | | |
|-------------------------|------|------|------|------|-----|
| 8-cent paper | 5.00 | 5.30 | 5.85 | 7.00 | .25 |
| 10-cent paper | 5.05 | 5.40 | 6.00 | 7.30 | .28 |
| 12-cent paper | 5.10 | 5.45 | 6.15 | 7.60 | .31 |
| 14-cent paper | 5.15 | 5.50 | 6.30 | 7.90 | .34 |
| 16-cent paper | 5.20 | 5.60 | 6.45 | 8.20 | .37 |
| 18-cent paper | 5.25 | 5.65 | 6.60 | 8.50 | .40 |
| 20-cent paper | 5.30 | 5.70 | 7.75 | 8.80 | .43 |

For difference in weight of stock, see half-letter or quarter-folio circulars.

The above figures include folding one fold.

Figure on 10c. paper and 20-lb. stock, unless requested otherwise.

HALF NOTE OR EIGHTH FOLIO CIRCULARS.

No form rated less than 50c. for composition. The figures in this table are based on 10 Point and \$1.00 for composition. The value of a full page of 12 Point is 75c.; 10 Point, \$1.00; 8 Point, \$1.50; 6 Point, \$2.00. The difference should be added or deducted from the gross figures.

20-lb. stock.

| | 100 | 250 | 500 | 1000 | ADDED 100 |
|---|--------|--------|--------|--------|-----------|
| 8-cent paper, \$0.60 per thousand | \$1.65 | \$1.90 | \$2.20 | \$2.90 | \$0.12 |
| 10-cent paper, .75 per thousand | 1.70 | 2.00 | 2.30 | 3.05 | .14 |
| 12-cent paper, .90 per thousand | 1.70 | 2.05 | 2.35 | 3.20 | .15 |
| 14-cent paper, 1.05 per thousand | 1.70 | 2.10 | 2.45 | 3.35 | .16 |
| 16-cent paper, 1.20 per thousand | 1.75 | 2.10 | 2.50 | 3.50 | .18 |
| 18-cent paper, 1.35 per thousand | 1.80 | 2.10 | 2.60 | 3.65 | .19 |
| 20-cent paper, 1.50 per thousand | 1.85 | 2.15 | 2.70 | 3.80 | .21 |

Printing front and back, add for composition only.

24-lb. stock will add for paper for each 1000 copies—on 8c. paper 12c., 10c. paper 15c., 12c. paper 19c., 14c. paper 21c., 16c. paper 25c., 18c. paper 28c., 20c. paper 31c.

FOLDED LETTER CIRCULARS.

Using half sheet demy or folio. The figures are based on 10 Point and \$2.00 for each page of composition. The value of a full page of 12 Point is \$1.50; 8 Point, \$3.00; 6 Point, \$4.00. The difference should be added or deducted from the gross figures.

One page, folded, 20-lb. stock.

| | 100 | 250 | 500 | 1000 | ADDED 100 |
|---|--------|--------|--------|--------|-----------|
| 8-cent paper, \$2.40 per thousand | \$3.25 | \$3.90 | \$4.80 | \$6.75 | \$0.37 |
| 10-cent paper, 3.00 per thousand | 3.30 | 4.05 | 5.10 | 7.35 | .43 |
| 12-cent paper, 3.60 per thousand | 3.35 | 4.20 | 5.40 | 7.95 | .49 |
| 14-cent paper, 4.20 per thousand | 3.40 | 4.35 | 5.70 | 8.55 | .55 |
| 16-cent paper, 4.80 per thousand | 3.45 | 4.50 | 6.00 | 9.15 | .61 |
| 18-cent paper, 5.40 per thousand | 3.50 | 4.65 | 6.30 | 9.75 | .67 |
| 20-cent paper, 6.00 per thousand | 3.55 | 4.80 | 6.60 | 10.35 | .73 |

Two pages, folded, 20-lb. stock.

| | | | | | |
|-------------------------|------|------|------|-------|-----|
| 8-cent paper | 5.25 | 5.90 | 6.80 | 8.75 | .37 |
| 10-cent paper | 5.30 | 6.05 | 7.10 | 9.35 | .43 |
| 12-cent paper | 5.35 | 6.20 | 7.40 | 9.95 | .49 |
| 14-cent paper | 5.40 | 6.35 | 7.70 | 10.55 | .55 |
| 16-cent paper | 5.45 | 6.50 | 8.00 | 11.15 | .61 |
| 18-cent paper | 5.50 | 6.65 | 8.30 | 11.75 | .67 |
| 20-cent paper | 5.55 | 6.80 | 8.60 | 12.35 | .73 |

Three pages, folded, 20-lb. stock.

| | | | | | |
|-------------------------|------|------|-------|-------|-----|
| 8-cent paper | 7.25 | 7.90 | 8.80 | 10.75 | .37 |
| 10-cent paper | 7.30 | 8.05 | 9.10 | 11.35 | .43 |
| 12-cent paper | 7.35 | 8.20 | 9.40 | 11.95 | .49 |
| 14-cent paper | 7.40 | 8.35 | 9.70 | 12.55 | .55 |
| 16-cent paper | 7.45 | 8.50 | 10.00 | 13.15 | .61 |
| 18-cent paper | 7.50 | 8.65 | 10.30 | 13.75 | .67 |
| 20-cent paper | 7.55 | 8.80 | 10.60 | 14.35 | .73 |

Four pages, folded, 20-lb. stock.

| | | | | | |
|-------------------------|------|-------|-------|-------|-----|
| 8-cent paper | 9.25 | 9.90 | 10.80 | 12.75 | .37 |
| 10-cent paper | 9.30 | 10.05 | 11.10 | 13.35 | .43 |
| 12-cent paper | 9.35 | 10.20 | 11.40 | 13.95 | .49 |
| 14-cent paper | 9.40 | 10.35 | 11.70 | 14.55 | .55 |
| 16-cent paper | 9.45 | 10.50 | 12.00 | 15.15 | .61 |
| 18-cent paper | 9.50 | 10.65 | 12.30 | 15.75 | .67 |
| 20-cent paper | 9.55 | 10.80 | 12.60 | 16.35 | .73 |

The above figures include folding one fold.

24-lb. stock will add for paper for each 1000 copies—on 8c. paper 50c., 10c. paper 62c., 12c. paper 75c., 14c. paper 88c., 16c. paper \$1.00, 18c. paper \$1.12, 20c. paper \$1.25.

Figure on 10c. paper and 20-lb. stock, unless requested otherwise.

CARD SCALE.

This is the scale referred to in the Price List of Business Cards on opposite page. The scale is based on 22x28 inch cardboard.

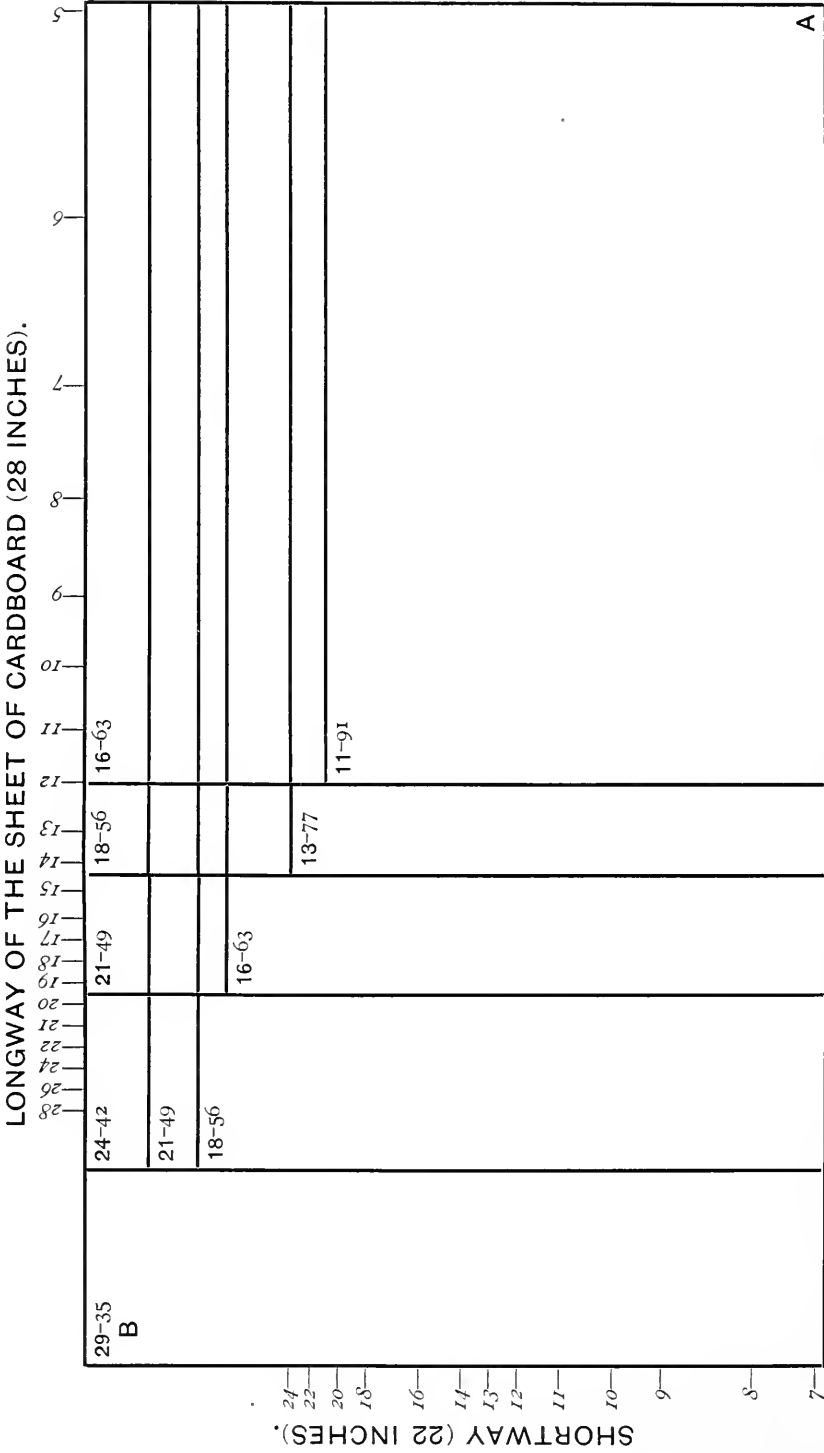

EXPLANATION.—The first figures in Gothic in the upper left-hand corner of each size indicate the number of sheets required for 1000 cards of that size. The figures in Roman, after the dash, indicate the number of cards that can be cut from one sheet of cardboard, *measuring from the lower right-hand corner of the scale (A)*.
 The Italic figures outside the scale indicate the number of cuts to a sheet for any size of card not exceeding the size of scale, measuring from the upper left-hand corner (B); and the number of cards procurable from a sheet may be ascertained by multiplying the shortwise and longwise numbers. Example: If a card measures from B longwise to 8 and from B shortwise to 8 the number of cards procurable from one full-sized sheet of 22x28 inch card will be 64.

CARD SCALE.

The card scale on opposite page agrees approximately with the card scales issued by various dealers in cardboard. There is no standard scale. Printers should procure the card scale of the dealers who supply them with cards. The "Convenient Card Scale and Table of Prices," compiled by Mr. C. F. Pedrick and copyrighted and issued to the trade by Irwin N. Megargee & Co., dealers in cards, 12 S. Sixth St., Philadelphia, will save printers a great deal of time and insure accuracy in estimating. This valuable scale shows at a glance: (1) Cost per 1000 cards of any size after being cut from any kind or quality of board, ranging in list price from \$1.00 to \$15.00 per 100 sheets, 22x28 inches; (2) Which way of the sheet a card of any size will cut to the best advantage; (3) Number of sheets of 22x28 inches cardboard required to cut 1000 cards of any size. This scale is printed on a large sheet of bond paper in two colors, and applicants for it should inclose ten cents in postage stamps.

BUSINESS CARDS.

The sizes and figures given for business cards such as 11-91, 50c. stand for 11 full sheets each cutting 91 cards, and the value, including cutting of 1000 of such cards, is 50 cents. On the general rule that all the prices given in these tables have a margin of profit the stock figures represent an addition to the cost of 50 per cent.

Costing \$1.60 for 100 full sheets.

| | 100 | 250 | 500 | 1000 | ADDED 100 |
|--------------------------------------|--------|--------|--------|--------|-----------|
| 11-91, \$0.50 per thousand | \$1.00 | \$1.20 | \$1.50 | \$2.00 | \$0.11 |
| 13-77, .56 per thousand | 1.05 | 1.25 | 1.60 | 2.25 | .12 |
| 16-63, .63 per thousand | 1.15 | 1.40 | 1.70 | 2.30 | .13 |
| 18-56, .68 per thousand | 1.20 | 1.45 | 1.80 | 2.50 | .14 |
| 21-49, .75 per thousand | 1.25 | 1.50 | 1.85 | 2.55 | .15 |
| 24-42, .82 per thousand | 1.30 | 1.60 | 1.95 | 2.70 | .15 |
| 29-35, .95 per thousand | 1.40 | 1.65 | 2.10 | 2.85 | .16 |

Costing \$2.00 for 100 full sheets.

| | 100 | 250 | 500 | 1000 | ADDED 100 |
|--------------------------------------|------|------|------|------|-----------|
| 11-91, \$0.58 per thousand | 1.00 | 1.20 | 1.50 | 2.10 | 0.12 |
| 13-77, .64 per thousand | 1.05 | 1.25 | 1.60 | 2.25 | .13 |
| 16-63, .75 per thousand | 1.15 | 1.40 | 1.75 | 2.45 | .14 |
| 18-56, .79 per thousand | 1.20 | 1.45 | 1.85 | 2.55 | .15 |
| 21-49, .88 per thousand | 1.25 | 1.60 | 1.95 | 2.70 | .16 |
| 24-42, .97 per thousand | 1.30 | 1.65 | 2.00 | 2.80 | .16 |
| 29-35, 1.12 per thousand | 1.40 | 1.70 | 2.20 | 3.10 | .18 |

Costing \$3.00 for 100 full sheets.

| | 100 | 250 | 500 | 1000 | ADDED 100 |
|--------------------------------------|------|------|------|------|-----------|
| 11-91, \$0.75 per thousand | 1.15 | 1.35 | 1.55 | 2.25 | 0.14 |
| 13-77, .83 per thousand | 1.30 | 1.55 | 1.70 | 2.45 | .15 |
| 16-63, .97 per thousand | 1.45 | 1.70 | 1.90 | 2.75 | .16 |
| 18-56, 1.01 per thousand | 1.45 | 1.75 | 1.95 | 2.85 | .17 |
| 21-49, 1.25 per thousand | 1.45 | 1.80 | 2.00 | 2.95 | .18 |
| 24-42, 1.33 per thousand | 1.75 | 2.05 | 2.35 | 3.35 | .20 |
| 29-35, 1.55 per thousand | 1.75 | 2.10 | 2.45 | 3.60 | .22 |

Costing \$4.00 for 100 full sheets.

| | 100 | 250 | 500 | 1000 | ADDED 100 |
|--------------------------------------|------|------|------|------|-----------|
| 11-91, \$0.91 per thousand | 1.20 | 1.45 | 1.85 | 2.65 | 0.15 |
| 13-77, 1.03 per thousand | 1.30 | 1.55 | 2.00 | 2.90 | .16 |
| 16-63, 1.21 per thousand | 1.50 | 1.80 | 2.30 | 3.30 | .18 |
| 18-56, 1.33 per thousand | 1.50 | 1.85 | 2.35 | 3.40 | .19 |
| 21-49, 1.51 per thousand | 1.50 | 1.95 | 2.40 | 3.55 | .21 |
| 24-42, 1.69 per thousand | 1.75 | 2.10 | 2.60 | 3.80 | .22 |
| 29-35, 1.99 per thousand | 1.80 | 2.20 | 2.90 | 4.25 | .24 |

Round-corner cards will add 50c. for each 1000, added to the foregoing figures.

For cheap entertainment cards use \$2.00 scale. For business cards use the \$4.00 scale, unless specially requested for another grade.

In colored ink, add 50c. to the gross price for any number under 1000, and 10c. for added 1000. For two forms, two colors, add \$1.00 to the gross price; presswork scale for second form.

Cards, backed with another form on cheap grades, add \$1.00, and print both sides at once. On grades on this page make separate presswork and charge 50c. and presswork scale to gross price.

BUSINESS CARDS—Continued.

(See Card Scale on page 1126.)

The finer grades of business cards should be rated somewhat higher than common grades, on account of the extra care in composition and presswork.

Costing \$5.00 per 100 full sheets.

| | 100 | 250 | 500 | 1000 | ADDED 100 |
|--------------------------------------|--------|--------|--------|--------|-----------|
| 11—91, \$1.02 per thousand | \$1.30 | \$1.60 | \$1.80 | \$2.70 | \$0.16 |
| 13—77, 1.17 per thousand | 1.30 | 1.65 | 2.10 | 3.10 | .18 |
| 16—63, 1.39 per thousand | 1.50 | 1.70 | 2.35 | 3.45 | .20 |
| 18—56, 1.54 per thousand | 1.50 | 1.85 | 2.40 | 3.55 | .21 |
| 21—49, 1.76 per thousand | 1.55 | 1.95 | 2.60 | 3.90 | .24 |
| 24—42, 1.98 per thousand | 1.80 | 2.20 | 3.00 | 4.40 | .26 |
| 29—35, 2.75 per thousand | 1.85 | 2.35 | 3.10 | 4.70 | .29 |

Costing \$6.00 per 100 full sheets.

| | | | | | |
|--------------------------------------|------|------|------|------|-----|
| 11—91, \$1.24 per thousand | 1.30 | 1.60 | 2.00 | 2.90 | .18 |
| 13—77, 1.42 per thousand | 1.35 | 1.70 | 2.25 | 3.35 | .21 |
| 16—63, 1.69 per thousand | 1.50 | 1.80 | 2.45 | 3.65 | .23 |
| 18—56, 1.87 per thousand | 1.55 | 1.90 | 2.60 | 3.90 | .25 |
| 21—49, 2.14 per thousand | 1.55 | 2.00 | 2.70 | 4.15 | .27 |
| 24—42, 2.41 per thousand | 1.85 | 2.25 | 3.15 | 4.75 | .30 |
| 29—35, 2.86 per thousand | 1.90 | 2.45 | 3.35 | 5.15 | .35 |

Costing \$7.00 per 100 full sheets.

| | | | | | |
|--------------------------------------|------|------|------|------|-----|
| 11—91, \$1.40 per thousand | 1.35 | 1.85 | 2.10 | 3.15 | .20 |
| 13—77, 1.61 per thousand | 1.40 | 1.90 | 2.30 | 3.50 | .22 |
| 16—63, 1.93 per thousand | 1.55 | 2.00 | 2.65 | 4.00 | .25 |
| 18—56, 2.14 per thousand | 1.60 | 2.10 | 2.70 | 4.15 | .27 |
| 21—49, 2.41 per thousand | 1.65 | 2.20 | 2.90 | 4.50 | .30 |
| 24—42, 2.77 per thousand | 1.90 | 2.30 | 3.25 | 5.00 | .34 |
| 29—35, 3.29 per thousand | 2.00 | 2.50 | 3.50 | 5.50 | .39 |

Costing \$8.00 per 100 full sheets.

| | | | | | |
|--------------------------------------|------|------|------|------|-----|
| 11—91, \$1.57 per thousand | 1.35 | 1.90 | 2.20 | 3.30 | .22 |
| 13—77, 1.81 per thousand | 1.45 | 1.95 | 2.40 | 3.70 | .24 |
| 16—63, 2.17 per thousand | 1.60 | 2.10 | 2.75 | 4.25 | .28 |
| 18—56, 2.41 per thousand | 1.65 | 2.20 | 2.85 | 4.45 | .30 |
| 21—49, 2.77 per thousand | 1.70 | 2.30 | 3.10 | 4.70 | .34 |
| 24—42, 3.13 per thousand | 1.95 | 2.40 | 3.45 | 5.25 | .37 |
| 29—35, 3.73 per thousand | 2.10 | 2.60 | 3.70 | 5.75 | .43 |

Above prices to govern professional cards.

In colored ink, add 50c. to the gross price for any number under 1000, and 10c. for added 1000. For two forms, two colors, add \$1.00 to the gross price; presswork scale for second form.

Cards backed with another form on cheap grades, add \$1.00, and print both sides at once. On grades on this page make separate presswork and charge 50c. and presswork scale on gross price.

ANNOUNCEMENT AND WEDDING INVITATIONS.

Full note, 80-lb., satin wove, with inside and outside envelopes, fine script type.

| | | | |
|-----------------------------------|--------|------------------------------------|--------|
| 25 copies, stock \$0.60 | \$2.50 | 100 copies, stock \$2.40 | \$5.50 |
| 50 copies, stock 1.20 | 3.50 | Added 100 copies | 4.00 |
| 75 copies, stock 1.80 | 4.50 | | |

VISITING AND WEDDING CARDS.

| | | | |
|----------------------------------|--------|----------------------------------|--------|
| 50 cards and printing | \$1.00 | 200 cards and printing | \$1.50 |
| 100 cards and printing | 1.25 | | |

ENGRAVED INVITATIONS AND CARD PLATES.

| | | | |
|--|---------|---|--------|
| 25 invitations on full note | \$ 9.00 | 50 cards and plate (name only) | \$1.75 |
| 50 invitations on full note | 10.00 | 100 cards and plate (name only) | 2.00 |
| 75 invitations on full note | 11.00 | Address or additional lines, each | .50 |
| 100 invitations on full note | 12.00 | 100 cards from plate | 1.25 |
| Additional 100 | 6.00 | Additional 100 | .80 |

ANNOUNCEMENT CARDS—BARONIAL.

Size 25—3½ × 4¾ inches—

| | 100 | 250 | 500 | 1000 | ADDED 100 |
|--|--------|--------|--------|--------|-----------|
| 5-cent stock, \$0.20 per hundred | \$1.75 | \$2.00 | \$2.65 | \$4.00 | \$0.26 |
| 6-cent stock, .23 per hundred | 1.85 | 2.15 | 2.90 | 4.55 | .31 |
| 7-cent stock, .26 per hundred | 1.95 | 2.20 | 3.10 | 4.95 | .35 |
| 8-cent stock, .30 per hundred | 2.00 | 2.25 | 3.15 | 5.05 | .36 |

Size 36—4 × 5 inches—

| | | | | | |
|--|------|------|------|------|-----|
| 5-cent stock, \$0.30 per hundred | 1.90 | 2.25 | 3.15 | 5.05 | .36 |
| 6-cent stock, .35 per hundred | 2.00 | 2.35 | 3.40 | 5.55 | .41 |
| 7-cent stock, .40 per hundred | 2.10 | 2.50 | 3.65 | 6.05 | .46 |
| 8-cent stock, .45 per hundred | 2.20 | 2.60 | 3.90 | 6.55 | .51 |

Baronial envelopes, without printing, No. 4, for size 25, cream or white, \$1.60 per 1000; and No. 5, for size 36, at \$2.00 per 1000. Linen XX, No. 4, \$1.80 per 1000, and No. 5, \$2.10 per 1000.

BALL AND DANCE PROGRAMMES.

Size 3½ × 4¾, when folded, cuts 16 to a sheet of card stock.

Value of Completed Work (Four Pages).

| ITEMS. | 50 | 100 | 200 | 300 |
|---------------------------------|--------|--------|--------|---------|
| Card stock | \$0.25 | \$0.50 | \$1.00 | \$1.50 |
| Composition | 2.40 | 2.40 | 2.40 | 2.40 |
| Presswork and scoring | 1.15 | 1.35 | 1.60 | 1.90 |
| Totals | \$3.80 | \$4.25 | \$5.00 | \$5.80 |
| Tassels and stringing | .60 | 1.00 | 1.75 | 2.50 |
| Pencils | .75 | 1.50 | 3.00 | 4.00 |
| Totals | \$5.15 | \$6.75 | \$9.75 | \$12.30 |

Colored ink will add \$1.00 to any of these prices. In two colors, add \$2.00 to above values.

If you use fancy programmes, increase the price, adding the list value of the programme to be used; the card stock charged for being equal to the expense of inserts and any additional forms of presswork on the programme.

LARGE CARDS OR POSTER ANNOUNCEMENTS.

The card stock in the following prices represents a cost value of \$2.50 per 100 full sheets.

BLACK INK.

Card Board 22 x 28—

| | 100 | 250 | 500 | 1000 | ADDED 100 |
|--|--------|--------|---------|---------|-----------|
| Eighth sheet, stock \$0.45 per hundred | \$2.95 | \$3.75 | \$ 5.10 | \$ 7.85 | \$0.55 |
| Quarter sheet, stock .90 per hundred | 3.90 | 5.40 | 7.90 | 12.90 | 1.00 |
| Third sheet, stock 1.20 per hundred | 5.20 | 7.30 | 10.80 | 17.80 | 1.40 |
| Half sheet, stock 1.75 per hundred | 6.25 | 9.25 | 14.25 | 24.25 | 2.00 |
| Whole sheet, stock 3.50 per hundred | 9.50 | 15.10 | 24.50 | 43.25 | 3.75 |

If in colored ink, add for first 100, \$1.00, and 5 cents for added 100 up to quarter sheets, and 10 cents for sizes over quarter sheets.

TWO COLORS OF INK.

| | 100 | 250 | 500 | 1000 | ADDED 100 |
|-------------------------|--------|---------|---------|---------|-----------|
| Eighth sheet | \$4.50 | \$ 5.70 | \$ 7.70 | \$11.70 | \$0.80 |
| Quarter sheet | 5.50 | 7.35 | 10.50 | 16.75 | 1.25 |
| Third sheet | 7.00 | 9.60 | 14.00 | 22.75 | 1.75 |
| Half sheet | 8.00 | 12.50 | 21.90 | 33.65 | 2.35 |
| Whole sheet | 12.00 | 18.30 | 28.80 | 49.80 | 4.20 |

BLOTTING PADS.

| | 12s | 16s | 20s |
|---|--------|--------|--------|
| | 4 × 9½ | 4¾ × 6 | 3¾ × 6 |
| 60-lb. stock at \$0.10 per lb., 1,000 | \$3.95 | \$3.55 | \$3.30 |
| Added 1,000 | 2.35 | 1.95 | 1.70 |
| 80-lb. stock at \$0.10 per lb., 1,000 | 4.45 | 3.90 | 3.60 |
| Added 1,000 | 2.85 | 2.30 | 2.00 |
| Enameled blotter, 1,000 | 5.90 | 5.00 | 4.50 |
| Added 1,000 | 4.30 | 3.45 | 2.90 |

In colored ink add \$2.00 for any number under 5000. Over 5000, add for colored ink 40c. per 1000.

BILL HEADS.

The usual sizes of stock-ruled bill heads are 6s, 4s, 3s and 2s of flat cap. The prices given are for ruled papers, costing the printer the prices named, at the rate per pound. If special ruling is required, the full expense of ruling must be added to the figures, because the grade of paper used would represent the value without ruling.

8-cent paper.

| | 100 | 250 | 500 | 1000 | ADDED 100 |
|---|--------|--------|--------|--------|-----------|
| 14-lb., 6s, \$0.56 per thousand | \$1.55 | \$1.75 | \$2.05 | \$2.65 | \$0.12 |
| 14-lb., 4s, .84 per thousand | 1.60 | 1.80 | 2.15 | 2.95 | .15 |
| 14-lb., 3s, 1.12 per thousand | 1.70 | 1.90 | 2.35 | 3.20 | .18 |
| 14-lb., 2s, 1.68 per thousand | 1.75 | 2.00 | 2.65 | 3.80 | .24 |

10-cent paper.

| | | | | | |
|---|------|------|------|------|-----|
| 14-lb., 6s, \$0.70 per thousand | 1.55 | 1.80 | 2.10 | 2.80 | .14 |
| 14-lb., 4s, 1.05 per thousand | 1.60 | 1.85 | 2.30 | 3.15 | .17 |
| 14-lb., 3s, 1.40 per thousand | 1.65 | 1.95 | 2.45 | 3.50 | .21 |
| 14-lb., 2s, 2.10 per thousand | 1.70 | 2.10 | 2.80 | 4.20 | .28 |
| 16-lb., 6s, .80 per thousand | 1.60 | 1.80 | 2.15 | 2.90 | .15 |
| 16-lb., 4s, 1.20 per thousand | 1.65 | 1.90 | 2.35 | 3.30 | .19 |
| 16-lb., 3s, 1.60 per thousand | 1.70 | 2.00 | 2.55 | 3.70 | .23 |
| 16-lb., 2s, 2.40 per thousand | 1.75 | 2.20 | 2.95 | 4.50 | .31 |

12-cent paper.

| | | | | | |
|---|------|------|------|------|-----|
| 14-lb., 6s, \$0.84 per thousand | 1.60 | 1.80 | 2.15 | 2.95 | .15 |
| 14-lb., 4s, 1.26 per thousand | 1.65 | 1.90 | 2.40 | 3.35 | .20 |
| 14-lb., 3s, 1.68 per thousand | 1.70 | 2.00 | 2.60 | 3.80 | .24 |
| 14-lb., 2s, 2.52 per thousand | 1.75 | 2.25 | 3.00 | 4.60 | .32 |
| 16-lb., 6s, .96 per thousand | 1.60 | 1.85 | 2.25 | 3.05 | .17 |
| 16-lb., 4s, 1.44 per thousand | 1.65 | 1.95 | 2.45 | 3.55 | .21 |
| 16-lb., 3s, 1.92 per thousand | 1.70 | 2.10 | 2.70 | 4.00 | .26 |
| 16-lb., 2s, 2.88 per thousand | 1.80 | 2.30 | 3.20 | 5.00 | .36 |

14-cent paper.

| | | | | | |
|---|------|------|------|------|-----|
| 14-lb., 6s, \$1.00 per thousand | 1.60 | 1.85 | 2.25 | 3.10 | .17 |
| 14-lb., 4s, 1.47 per thousand | 1.65 | 1.95 | 2.50 | 3.55 | .22 |
| 14-lb., 3s, 1.95 per thousand | 1.70 | 2.10 | 2.75 | 4.05 | .27 |
| 14-lb., 2s, 2.94 per thousand | 1.80 | 2.35 | 3.20 | 5.05 | .36 |
| 16-lb., 6s, 1.13 per thousand | 1.60 | 1.90 | 2.30 | 3.20 | .18 |
| 16-lb., 4s, 1.68 per thousand | 1.65 | 2.00 | 2.60 | 3.80 | .24 |
| 16-lb., 3s, 2.25 per thousand | 1.75 | 2.15 | 2.90 | 4.35 | .30 |
| 16-lb., 2s, 3.36 per thousand | 1.85 | 2.45 | 3.45 | 5.45 | .41 |

Assorted 1000s, use the 1000 price for each size, cutting off the right-hand figure, giving the price per 100.

Give the figures for 12c. ruled stock and 14-lb. weight, unless specially requested for other grades.

MONTHLY STATEMENTS.

Stock-ruled statements are generally made from 20-lb. or 24-lb. folio, and have various designations. The regular size, 8s of folio, is $5\frac{1}{2} \times 8\frac{1}{2}$ inches; square statements, 12s of folio, $5\frac{1}{2} \times 5\frac{1}{2}$ inches; yankee statements, 12s of folio, $3\frac{1}{2} \times 8\frac{1}{2}$ inches; infant statements, 16s of folio, $4\frac{1}{4} \times 5\frac{1}{2}$ inches; and gem statements, 18s of folio, $3\frac{1}{3} \times 5\frac{1}{2}$ inches.

10-cent paper, 20-lb. stock.

| | 100 | 250 | 500 | 1000 | ADDED 100 |
|---|--------|--------|--------|--------|-----------|
| 8s, regular, \$0.75 per thousand | \$1.25 | \$1.70 | \$2.00 | \$2.75 | \$0.14 |
| 12s, square or yankee, .50 per thousand | 1.25 | 1.60 | 1.85 | 2.50 | .11 |
| 16s, infant, .38 per thousand | 1.25 | 1.50 | 1.80 | 2.40 | .10 |
| 18s, gem, .34 per thousand | 1.25 | 1.50 | 1.80 | 2.35 | .09 |

10-cent paper, 24-lb. stock.

| | | | | | |
|---|------|------|------|------|-----|
| 8s, regular \$0.90 per thousand | 1.30 | 1.70 | 2.05 | 2.90 | .15 |
| 12s, square or yankee, .60 per thousand | 1.30 | 1.60 | 1.90 | 2.60 | .12 |
| 16s, infant, .45 per thousand | 1.30 | 1.55 | 1.85 | 2.45 | .11 |
| 18s, gem, .40 per thousand | 1.30 | 1.55 | 1.80 | 2.40 | .10 |

MONTHLY STATEMENTS—Continued.

| 12-cent paper, 20-lb. stock. | | 100 | 250 | 500 | 1000 | ADDED 100 |
|------------------------------|-------------------------------|--------|--------|--------|--------|-----------|
| 8s, regular, | \$0.90 per thousand | \$1.30 | \$1.70 | \$2.05 | \$2.90 | \$0.15 |
| 12s, square or yankee, | .60 per thousand | 1.30 | 1.60 | 1.90 | 2.60 | .12 |
| 16s, infant, | .45 per thousand | 1.30 | 1.55 | 1.85 | 2.45 | .11 |
| 18s, gem, | .40 per thousand | 1.30 | 1.55 | 1.80 | 2.40 | .10 |

| 12-cent paper, 24-lb. stock. | | 100 | 250 | 500 | 1000 | ADDED 100 |
|------------------------------|-------------------------------|------|------|------|------|-----------|
| 8s, regular, | \$1.08 per thousand | 1.35 | 1.75 | 2.15 | 3.10 | .17 |
| 12s, square or yankee, | .72 per thousand | 1.35 | 1.65 | 1.95 | 2.70 | .13 |
| 16s, infant, | .54 per thousand | 1.35 | 1.60 | 1.90 | 2.55 | .12 |
| 18s, gem, | .48 per thousand | 1.35 | 1.60 | 1.85 | 2.50 | .11 |

| 14-cent paper, 20-lb. stock. | | 100 | 250 | 500 | 1000 | ADDED 100 |
|------------------------------|-------------------------------|------|------|------|------|-----------|
| 8s, regular, | \$1.05 per thousand | 1.35 | 1.75 | 2.15 | 3.10 | .17 |
| 12s, square or yankee, | .70 per thousand | 1.35 | 1.65 | 1.95 | 2.70 | .13 |
| 16s, infant, | .53 per thousand | 1.35 | 1.60 | 1.90 | 2.55 | .11 |
| 18s, gem, | .47 per thousand | 1.35 | 1.60 | 1.85 | 2.50 | .11 |

| 14-cent paper, 24-lb. stock. | | 100 | 250 | 500 | 1000 | ADDED 100 |
|------------------------------|-------------------------------|------|------|------|------|-----------|
| 8s, regular, | \$1.26 per thousand | 1.40 | 1.80 | 2.25 | 3.25 | .19 |
| 12s, square or yankee, | .84 per thousand | 1.40 | 1.65 | 2.00 | 2.85 | .15 |
| 16s, infant, | .63 per thousand | 1.40 | 1.60 | 1.95 | 2.65 | .12 |
| 18s, gem, | .56 per thousand | 1.40 | 1.60 | 1.90 | 2.55 | .12 |

Use 12c. paper and 20-lb. stock, unless specially requested to furnish some other grade.

LETTER HEADS.

Usually printed on quarter-sheet folio, the grades of paper differing very materially ; but, with the designation of cost values of the stock, the figures cover all the grades from a cheap writing to a first-class linen paper. The prices are maximum, and may be adjusted by a uniform discount. One-third off prices given here will bring most jobs to about the cost value :

| 8-cent paper. | | 100 | 250 | 500 | 1000 | ADDED 100 |
|---------------|-------------------------------|--------|--------|--------|--------|-----------|
| 8-lb. stock, | \$0.96 per thousand | \$1.25 | \$1.85 | \$2.25 | \$3.05 | \$0.17 |
| 10-lb. stock, | 1.20 per thousand | 1.25 | 1.90 | 2.35 | 3.30 | .19 |
| 12-lb. stock, | 1.44 per thousand | 1.50 | 1.95 | 2.45 | 3.55 | .21 |

| 10-cent paper. | | 100 | 250 | 500 | 1000 | ADDED 100 |
|----------------|-------------------------------|------|------|------|------|-----------|
| 8-lb. stock, | \$1.20 per thousand | 1.50 | 1.90 | 2.35 | 3.30 | .19 |
| 10-lb. stock, | 1.50 per thousand | 1.50 | 2.00 | 2.50 | 3.60 | .22 |
| 12-lb. stock, | 1.80 per thousand | 1.50 | 2.05 | 2.65 | 3.90 | .25 |

| 12-cent paper. | | 100 | 250 | 500 | 1000 | ADDED 100 |
|----------------|-------------------------------|------|------|------|------|-----------|
| 8-lb. stock, | \$1.44 per thousand | 1.50 | 1.95 | 2.45 | 3.55 | .22 |
| 10-lb. stock, | 1.80 per thousand | 1.50 | 2.05 | 2.65 | 3.90 | .25 |
| 12-lb. stock, | 2.16 per thousand | 1.50 | 2.15 | 2.85 | 4.15 | .29 |

| 14-cent paper. | | 100 | 250 | 500 | 1000 | ADDED 100 |
|----------------|-------------------------------|------|------|------|------|-----------|
| 8-lb. stock, | \$1.68 per thousand | 1.50 | 2.00 | 2.60 | 3.80 | .24 |
| 10-lb. stock, | 2.10 per thousand | 1.50 | 2.10 | 2.80 | 4.20 | .28 |
| 12-lb. stock, | 2.52 per thousand | 1.50 | 2.25 | 3.00 | 4.60 | .32 |

| 16-cent paper. | | 100 | 250 | 500 | 1000 | ADDED 100 |
|----------------|-------------------------------|------|------|------|------|-----------|
| 8-lb. stock, | \$1.92 per thousand | 1.50 | 2.10 | 2.70 | 4.00 | .26 |
| 10-lb. stock, | 2.40 per thousand | 1.50 | 2.20 | 2.95 | 4.50 | .31 |
| 12-lb. stock, | 2.88 per thousand | 1.50 | 2.30 | 3.20 | 5.00 | .36 |

| 18-cent paper. | | 100 | 250 | 500 | 1000 | ADDED 100 |
|----------------|-------------------------------|------|------|------|------|-----------|
| 8-lb. stock, | \$2.16 per thousand | 1.50 | 2.15 | 2.85 | 4.25 | .29 |
| 10-lb. stock, | 2.70 per thousand | 1.50 | 2.30 | 3.10 | 4.80 | .34 |
| 12-lb. stock, | 3.24 per thousand | 1.50 | 2.40 | 3.35 | 5.35 | .39 |

| 20-cent paper. | | 100 | 250 | 500 | 1000 | ADDED 100 |
|----------------|-------------------------------|------|------|------|------|-----------|
| 8-lb. stock, | \$2.40 per thousand | 1.50 | 2.20 | 2.95 | 4.50 | .31 |
| 10-lb. stock, | 3.00 per thousand | 1.50 | 2.35 | 3.25 | 5.10 | .37 |
| 12-lb. stock, | 3.60 per thousand | 1.50 | 2.50 | 3.55 | 5.70 | .43 |

Figure on 12c. paper and 10-lb. stock, unless otherwise requested.

NOTE AND MEMORANDUM HEADINGS.

This class of work is usually printed on 8s of folio, either the broad or narrow way. The different values of paper represent the cost to the printer. One-third off the prices given here will bring most jobs to about the cost value :

8-cent paper.

| | 100 | 250 | 500 | 1000 | ADDED 100 |
|--|--------|--------|--------|--------|-----------|
| 4-lb. stock, \$0.48 per thousand | \$1.25 | \$1.75 | \$2.00 | \$2.60 | \$0.12 |
| 5-lb. stock, .60 per thousand | 1.25 | 1.75 | 2.05 | 2.70 | .13 |

10-cent paper.

| | | | | | |
|--|------|------|------|------|-----|
| 4-lb. stock, \$0.60 per thousand | 1.50 | 1.75 | 2.05 | 2.70 | .13 |
| 5-lb. stock, .75 per thousand | 1.50 | 1.80 | 2.15 | 2.85 | .15 |
| 6-lb. stock, .90 per thousand | 1.50 | 1.85 | 2.20 | 3.00 | .16 |
| 7-lb. stock, 1.05 per thousand | 1.50 | 1.90 | 2.30 | 3.15 | .17 |

12-cent paper.

| | | | | | |
|--|------|------|------|------|-----|
| 4-lb. stock, \$0.72 per thousand | 1.50 | 1.80 | 2.10 | 2.80 | .14 |
| 5-lb. stock, .90 per thousand | 1.50 | 1.85 | 2.20 | 3.00 | .16 |
| 6-lb. stock, 1.08 per thousand | 1.50 | 1.90 | 2.30 | 3.20 | .18 |
| 7-lb. stock, 1.26 per thousand | 1.50 | 1.90 | 2.40 | 3.35 | .20 |

14-cent paper.

| | | | | | |
|--|------|------|------|------|-----|
| 4-lb. stock, \$0.84 per thousand | 1.50 | 1.80 | 2.25 | 2.95 | .15 |
| 5-lb. stock, 1.05 per thousand | 1.50 | 1.90 | 2.30 | 3.15 | .18 |
| 6-lb. stock, 1.26 per thousand | 1.50 | 1.90 | 2.40 | 3.35 | .20 |
| 7-lb. stock, 1.47 per thousand | 1.50 | 2.00 | 2.50 | 3.55 | .22 |

16-cent paper.

| | | | | | |
|--|------|------|------|------|-----|
| 4-lb. stock, \$0.96 per thousand | 1.50 | 1.85 | 2.25 | 3.15 | .17 |
| 5-lb. stock, 1.20 per thousand | 1.50 | 1.90 | 2.35 | 3.30 | .19 |
| 6-lb. stock, 1.44 per thousand | 1.50 | 1.95 | 2.45 | 3.55 | .22 |
| 7-lb. stock, 1.68 per thousand | 1.50 | 2.05 | 2.60 | 3.80 | .24 |

18-cent paper.

| | | | | | |
|--|------|------|------|------|-----|
| 4-lb. stock, \$1.08 per thousand | 1.50 | 1.90 | 2.30 | 3.20 | .18 |
| 5-lb. stock, 1.35 per thousand | 1.50 | 1.95 | 2.45 | 3.45 | .21 |
| 6-lb. stock, 1.62 per thousand | 1.50 | 2.00 | 2.55 | 3.70 | .23 |
| 7-lb. stock, 1.89 per thousand | 1.50 | 2.10 | 2.70 | 4.00 | .26 |

20-cent paper.

| | | | | | |
|--|------|------|------|------|-----|
| 4-lb. stock, \$1.20 per thousand | 1.50 | 1.90 | 2.35 | 3.30 | .19 |
| 5-lb. stock, 1.50 per thousand | 1.50 | 1.95 | 2.50 | 3.60 | .22 |
| 6-lb. stock, 1.80 per thousand | 1.50 | 2.00 | 2.65 | 3.90 | .25 |
| 7-lb. stock, 2.10 per thousand | 1.50 | 2.15 | 2.80 | 4.20 | .28 |

Figure on 12c. paper and 5-lb. stock, unless otherwise requested.

BEER OR MILK TICKETS.

On heavy, tough check, 100 for \$1.00; 500 for \$1.50; 1000 for \$2.00; change of price or quantity in same order, 20c. for each change.

RESTAURANT AND HOTEL BILLS OF FARE.

- Breakfast or supper, 8s of 24-lb. folio post, at 12c.
- 500 copies, \$3.30; 1,000 copies, \$4.50. Added 1,000 copies, \$1.90.
- Dinner bills, same general style, printed on two sides.
- 500 copies, \$4.95; 1,000 copies, \$6.00. Added 1,000 copies, \$2.50.
- Dinner bills, 4 pages, quarter-sheet folio with wine list.
- 500 copies, \$7.50; 1,000 copies, \$9.15. Added 1,000 copies, \$3.60.
- Skeleton bills to be filled in daily.
- 12s of thin card per 1,000, \$5.65. Added 1,000, \$3.30.
- Restaurant bills on 6s of flat cap.
- 500 copies, \$3.00; 1,000 copies, \$4.00. Added 1,000 copies, \$1.80.

ENVELOPES.

In this list of prices there is one-third added to the general net cost price.

No. 6 Size.

| | | 100 | 250 | 500 | 1000 | ADDED 100 |
|------------------------|---------------------|--------|--------|--------|--------|-----------|
| 60-lb. No. 1 rag, | \$1.60 per thousand | \$1.00 | \$1.35 | \$1.90 | \$3.10 | \$0.22 |
| 50-lb. No. 1 rag, | 1.47 per thousand | 1.00 | 1.35 | 1.85 | 2.95 | .21 |
| 60-lb. No. 2 rag, | 1.35 per thousand | 1.00 | 1.30 | 1.80 | 2.85 | .20 |
| 50-lb. No. 2 rag, | 1.27 per thousand | 1.00 | 1.25 | 1.75 | 2.75 | .19 |
| 60-lb. No. 1 wood, | 1.13 per thousand | 1.00 | 1.25 | 1.65 | 2.65 | .17 |
| 50-lb. No. 1 wood, | 1.00 per thousand | 1.00 | 1.20 | 1.60 | 2.50 | .16 |
| 50-lb. manilla, | .87 per thousand | 1.00 | 1.20 | 1.55 | 2.35 | .15 |
| 36-lb. manilla, white, | 1.00 per thousand | 1.00 | 1.20 | 1.60 | 2.50 | .16 |
| 36-lb. manilla, | .73 per thousand | 1.00 | 1.15 | 1.45 | 2.25 | .13 |

No. 6 1/2 Size.

| | | | | | | |
|------------------------|-------------------|------|------|------|------|-----|
| 60-lb. No. 1 rag, | 1.80 per thousand | 1.00 | 1.40 | 2.00 | 3.30 | .24 |
| 50-lb. No. 1 rag, | 1.53 per thousand | 1.00 | 1.40 | 1.90 | 3.00 | .21 |
| 60-lb. No. 2 rag, | 1.53 per thousand | 1.00 | 1.40 | 1.90 | 3.00 | .21 |
| 50-lb. No. 2 rag, | 1.33 per thousand | 1.00 | 1.30 | 1.80 | 2.90 | .20 |
| 60-lb. No. 1 wood, | 1.27 per thousand | 1.00 | 1.30 | 1.75 | 2.80 | .19 |
| 50-lb. No. 1 wood, | 1.07 per thousand | 1.00 | 1.25 | 1.65 | 2.60 | .17 |
| 50-lb. manilla, | 1.00 per thousand | 1.00 | 1.25 | 1.60 | 2.50 | .16 |
| 36-lb. manilla, white, | 1.07 per thousand | 1.00 | 1.25 | 1.65 | 2.60 | .17 |
| 36-lb. manilla, | .80 per thousand | 1.00 | 1.20 | 1.50 | 2.30 | .14 |

No. 10 Size

| | | | | | | |
|-------------------|-------------------|------|------|------|------|-----|
| 60-lb. No. 1 rag, | 2.87 per thousand | 1.25 | 1.70 | 2.55 | 4.40 | .37 |
| 50-lb. No. 1 rag, | 2.47 per thousand | 1.25 | 1.65 | 2.40 | 3.95 | .33 |
| 60-lb. No. 2 rag, | 2.53 per thousand | 1.25 | 1.65 | 2.40 | 4.00 | .33 |
| 50-lb. No. 2 rag, | 2.20 per thousand | 1.25 | 1.55 | 2.25 | 3.75 | .30 |
| 50-lb. manilla, | 1.53 per thousand | 1.25 | 1.40 | 1.90 | 3.00 | .23 |
| 36-lb. manilla, | 1.27 per thousand | 1.00 | 1.30 | 1.75 | 2.80 | .21 |

No. 11 Size.

| | | | | | | |
|-------------------|-------------------|------|------|------|------|-----|
| 60-lb. No. 1 rag, | 3.45 per thousand | 1.30 | 1.85 | 2.85 | 5.00 | .45 |
| 50-lb. No. 1 rag, | 3.00 per thousand | 1.30 | 1.70 | 2.65 | 4.45 | .40 |

No. 12 Size.

| | | | | | | |
|-------------------|-------------------|------|------|------|------|-----|
| 60-lb. No. 1 rag, | 4.05 per thousand | 1.40 | 2.00 | 3.15 | 5.60 | .50 |
| 50-lb. No. 1 rag, | 3.40 per thousand | 1.40 | 1.90 | 2.90 | 4.95 | .44 |

FOR PRINTING ONLY—STOCK FURNISHED.

| | | | | | |
|-----------------|--------|-----------------|--------|------------------|---------|
| 500 | \$1.25 | 5,000 | \$4.95 | 10,000 | \$ 8.75 |
| 1,000 | 1.75 | 6,000 | 5.75 | 15,000 | 11.75 |
| 2,000 | 2.55 | 7,000 | 6.50 | 20,000 | 14.75 |
| 3,000 | 3.35 | 8,000 | 7.25 | 25,000 | 17.75 |
| 4,000 | 4.15 | 9,000 | 8.00 | | |

Figure on 50-lb. No. 2 rag for ordinary business, unless otherwise requested. Colored envelopes on same grade.

DENNISON TAG ENVELOPE.

FOR SENDING BILLS WITH PACKAGE.

| | | | |
|---|--------|---|--------|
| No. 17 P., 6 x 3 1/2, not printed, per thousand | \$3.25 | No. 18 P., 7 1/2 x 3 3/4, not printed, per thousand | \$4.20 |
| Printed, per thousand | 4.50 | Printed, per thousand | 5.50 |

DENNISON CLASP ENVELOPE.

OPEN-END XXXX WEIGHT.

| | | | |
|--|--------|--|--------|
| Size, 3 3/8 x 6 inches, per thousand | \$4.50 | Size, 5 1/4 x 8 inches, per thousand | \$5.75 |
| Size, 4 x 6 inches, per thousand | 4.75 | Size, 5 1/2 x 8 1/4 inches, per thousand | 6.00 |
| Size, 3 7/8 x 7 1/2 inches, per thousand | 5.75 | Size, 6 x 9 inches, per thousand | 6.25 |
| Size, 4 3/8 x 6 3/4 inches, per thousand | 5.00 | Size, 6 1/4 x 9 1/2 inches, per thousand | 6.75 |
| Size, 4 7/8 x 7 1/4 inches, per thousand | 5.00 | Size, 6 1/2 x 10 inches, per thousand | 7.50 |
| Size, 5 x 7 1/2 inches, per thousand | 5.50 | Size, 7 x 10 1/2 inches, per thousand | 8.00 |

Printing, add \$1.50 per 1000.

POSTAL CARDS AND STAMPED ENVELOPES.

The customer should supply postal cards and stamped envelopes. When the stock is furnished by office the prices should be net.

| Postal Cards, printed on one side. | STOCK FURNISHED | STOCK |
|------------------------------------|----------------------------|---------------------------|
| | BY OFFICE. NET FIGURES. | FURNISHED BY CUSTOMER. |
| 100 cards | \$2.00 | \$1.00 |
| 200 cards | 3.20 | 1.10 |
| 300 cards | 4.40 | 1.20 |
| 400 cards | 5.50 | 1.35 |
| 500 cards | 6.60 | 1.50 |
| 1,000 cards | 12.50 | 2.00 |
| Additional 1,000 | 11.50 | 1.00 |

Printing on two sides, add the last column of figures for the second run.

Stamped Envelopes, 2-cent postage, white, commercial size.

| | | |
|---|-------|------|
| 100 envelopes, \$21.80 per thousand | 3.40 | 1.00 |
| 200 envelopes, 21.80 per thousand | 5.80 | 1.10 |
| 300 envelopes, 21.80 per thousand | 8.00 | 1.20 |
| 400 envelopes, 21.80 per thousand | 10.40 | 1.35 |
| 500 envelopes, 21.80 per thousand | 12.80 | 1.50 |
| 1,000 envelopes, 21.80 per thousand | 24.45 | 2.00 |
| Additional 1,000 | 23.80 | 1.00 |

One-cent postage, manilla, commercial size.

| | | |
|---|-------|------|
| 100 envelopes, \$11.08 per thousand | 2.00 | 1.00 |
| 200 envelopes, 11.08 per thousand | 3.40 | 1.10 |
| 300 envelopes, 11.08 per thousand | 4.80 | 1.20 |
| 400 envelopes, 11.08 per thousand | 6.20 | 1.35 |
| 500 envelopes, 11.08 per thousand | 7.50 | 1.50 |
| 1,000 envelopes, 11.08 per thousand | 14.00 | 2.00 |
| Additional 1,000 | 12.60 | 1.00 |

One-cent postage, white, commercial size, add 8c. per 100 extra to manilla prices for stock furnished by office.

SHIPPING TAGS.

The following are list prices on Dennison tags, without printing :

| SIZE. | N. Y. G. | DEN. E. | STAND- ARD P. | SIZE. | N. Y. G. | DEN. E. | STAND- ARD P. |
|-------------|----------|---------|------------------|-------------|----------|---------|------------------|
| 1 | \$0.25 | \$0.40 | \$0.90 | 5 | \$0.50 | \$0.85 | \$1.60 |
| 2 | .30 | .50 | 1.00 | 6 | .60 | 1.00 | 1.90 |
| 3 | .35 | .60 | 1.20 | 7 | .70 | 1.15 | 2.30 |
| 4 | .40 | .70 | 1.40 | 8 | .80 | 1.30 | 2.75 |

COLORED AND LINEN TAGS.

| SIZE. | NOVELTY COL. | PAT. COL. | LINEN. | SIZE. | NOVELTY COL. | PAT. COL. | LINEN. |
|-------------|--------------|-----------|--------|-------------|--------------|-----------|--------|
| 1 | \$0.75 | \$1.25 | \$3.00 | 5 | \$1.60 | \$2.75 | \$6.25 |
| 2 | .90 | 1.50 | 3.75 | 6 | 1.90 | 3.00 | 7.25 |
| 3 | 1.10 | 2.00 | 4.50 | 7 | 2.20 | 3.50 | 8.50 |
| 4 | 1.30 | 2.25 | 5.25 | 8 | 2.50 | 3.75 | 10.00 |

Add for printing to any one kind for 1000, \$1.50; for additional 1000s to 4000, 60c. per 1000; 5000 to 10,000, at 60c. per 1000; over 10,000, at 50c. per 1000. Discounts to be figured from the whole amount.

HOTEL REGISTERS.

Interleaved with blotting paper without advertisements.

| | DEMY OR MEDIUM. |
|---|-----------------|
| Books of 300 pages without blotters | \$9.50 |
| Add for blotters | 2.00 |
| Total for one book | \$11.50 |
| Added books in same order | 7.80 |

PRINTED DRAFTS AND INDIVIDUAL CHECKS, BOUND.

| | | |
|--|------------|-------------|
| | 500 FORMS. | 1000 FORMS. |
| Five forms to a half sheet of folio or royal, one book | \$7.90 | \$10.10 |
| Additional books in same order | 3.30 | 5.50 |

These are for numbered and perforated forms.

In books two or three deep, add 50c. for additional binding on each 1000 forms.

The names of drawers inserted where there is more than one order ; charge, 50c. extra for each set of names. Names of drawers in red or other color, \$1.00 extra.

CUSTOMERS' CHECKS IN SMALL BOOKS.

| | | | |
|--|----------|----------|---------|
| Check Bound Books.— | 20 BOOKS | 10 BOOKS | 2 BOOKS |
| | OF 50. | OF 100. | OF 500. |
| Total for 1,000 checks | \$ 5.70 | \$ 5.30 | \$ 4.90 |
| Additional 1,000s | 3.70 | 3.30 | 2.90 |
| In lots of 5,000, setting two forms | 15.60 | 14.10 | 13.00 |
| In lots of 10,000, setting full form | 27.00 | 25.00 | 25.00 |
| In additional lots of 10,000 | 23.00 | 21.00 | 21.00 |

Twelve checks to one sheet of folio, reduce 15c. per 1000 checks, the paper (24-lb. folio) amounting to 75c. ; all other charges the same.

BANK OR COUNTER CHECKS.

WITHOUT STUBS, LOOSE OR IN BLOCKS. SMALL, 2¼×7¼ INCHES, 18S FOLIO (STOCK, 40C.).

| | | |
|-------------------------|-------------------------|-------------------------|
| 1,000 \$ 2.00 | 2,000 \$ 3.00 | 3,000 \$ 4.00 |
| 5,000 6.00 | 10,000 10.00 | 20,000 19.00 |
| 30,000 25.00 | 40,000 30.00 | 50,000 35.00 |

Large, 3½×8½ inches, 8s cap (stock, 50c.).

| | | |
|-------------------------|-------------------------|-------------------------|
| 1,000 \$ 2.50 | 2,000 \$ 3.65 | 3,000 \$ 4.95 |
| 5,000 7.00 | 10,000 12.00 | 20,000 20.00 |
| 30,000 27.00 | 40,000 34.00 | 50,000 40.00 |

These prices are for loose checks, or simply glued in bulk at the top. If in blocks of 50, add 30c. per 1000 for the first 1000 and 20c. for subsequent 1000s.

Colored inks will add \$1.00 to the order.

DEBIT AND CREDIT SLIPS.

2¼×4¼, 32s folio (stock, 15c.).

| | | |
|-------------------------|-------------------------|-------------------------|
| 1,000 \$ 1.25 | 2,000 \$ 1.70 | 3,000 \$ 2.00 |
| 5,000 3.00 | 10,000 5.00 | 20,000 9.00 |
| 30,000 13.00 | 40,000 17.00 | 50,000 21.00 |

3⅝×4¼, 24s folio (stock, 20c.).

| | | |
|-------------------------|-------------------------|-------------------------|
| 1,000 \$ 1.25 | 2,000 \$ 1.80 | 3,000 \$ 2.20 |
| 5,000 3.25 | 10,000 5.50 | 20,000 10.00 |
| 30,000 14.50 | 40,000 19.00 | 50,000 23.00 |

DEPOSIT TICKETS.

3½×5½, 20s of 20-lb. folio post at 8c. (paper 25c.).

| | | |
|-------------------------|-------------------------|-------------------------|
| 1,000 \$ 1.50 | 2,000 \$ 2.00 | 3,000 \$ 2.50 |
| 5,000 3.50 | 10,000 6.00 | 20,000 11.00 |
| 30,000 16.00 | 40,000 21.00 | 50,000 25.00 |

4½×7, 8s of 12-lb. cap at 8c. (paper 38c.).

| | | |
|-------------------------|-------------------------|-------------------------|
| 1,000 \$ 1.50 | 2,000 \$ 2.30 | 3,000 \$ 3.15 |
| 5,000 4.25 | 10,000 7.50 | 20,000 14.00 |
| 30,000 20.00 | 40,000 26.00 | 50,000 31.00 |

CERTIFICATES OF DEPOSIT.

PRINTED TWO ON A LEAF OF FOLDED HALF ROYAL.

| | | |
|---|-------------|-------------|
| | 500 FORMS.. | 1000 FORMS. |
| Printed two forms on a leaf, using bond paper | \$7.35 | \$10.00 |
| Additional books in same order | 3.60 | 7.00 |

NOTICES OF NOTES AND ACCEPTANCES.

3½ × 5½, 20s of 20-lb. folio post (paper 30c.).

| | | | | | |
|------------------|---------|------------------|---------|------------------|---------|
| 1,000 | \$ 1.50 | 2,000 | \$ 2.40 | 3,000 | \$ 3.30 |
| 5,000 | 4.20 | 10,000 | 8.00 | 20,000 | 15.00 |
| 30,000 | 21.00 | 40,000 | 26.00 | 50,000 | 30.00 |

BONDS AND COUPONS.

| | | | |
|--|---------|---------|---------|
| Township, school district, village and city bonds. | | | |
| | 25 | 50 | 100 |
| | COPIES. | COPIES. | COPIES. |
| Bond with 10 coupons | \$ 8.75 | \$ 8.95 | \$ 9.40 |
| Additional 100 copies, \$2.40. | | | |
| Full sheet cap bond with 20 coupons | 14.00 | 15.00 | 16.00 |
| Additional 100 copies, \$3.30. | | | |

RULED AND PRINTED BLANKS.

| | | |
|--|---------|--------|
| Double Cap (32-lb. paper, \$1.20 per hundred ; ruling, \$2.50). | 100 | ADDED |
| | COPIES. | 100. |
| One form on a sheet, one side | \$7.10 | \$1.50 |
| Same, backed with one fold | 9.10 | 1.65 |
| Backed with same form | 7.35 | 1.90 |
| Two forms on a sheet, one side | 7.35 | 1.65 |
| Three forms on a sheet, one side | 7.55 | 1.95 |
| Four forms on a sheet, one side, setting two | 9.30 | 1.80 |
| Side lines of figures, etc., adjusted to ruled lines, will add \$2.00 to first 100 copies. | | |

| | | |
|--|------|------|
| Folio Post (24-lb. paper, 90c. per hundred ; ruling, \$2.50). | | |
| One form on a sheet | 6.00 | 1.25 |
| Same, backed with one fold | 8.25 | 1.30 |
| Backed with same form | 6.30 | 1.60 |
| Two forms on a sheet, one side | 6.25 | 1.50 |
| Three forms on a sheet | 6.50 | 1.70 |
| Four forms on a sheet | 7.05 | 1.50 |
| Side lines of figures, etc., adjusted to ruled lines, will add \$2.00 to first 100 copies. | | |

| | | |
|---|------|------|
| Cap (16-lb. paper, 60c. per hundred ; ruling, \$2.00). | | |
| One form on a sheet | 4.70 | .80 |
| Same, backed with one fold | 6.35 | .90 |
| Backed with same form | 4.90 | 1.05 |
| Two forms on a sheet, one side, setting two | 5.80 | .90 |
| Three forms on a sheet, setting three | 7.00 | 1.00 |
| Four forms on a sheet | 6.10 | 1.15 |

| | | |
|--|------|-----|
| Half-Sheet Folio (24-lb. paper, 45c. per hundred ; ruling, \$1.50). | | |
| One form on a sheet, one side | 4.45 | .75 |
| Same, backed, with one fold | 6.20 | .90 |
| Backed with same form | 4.70 | .90 |
| Two forms on a sheet, one side, setting two | 5.65 | .75 |
| Three forms on a sheet, one side, setting three | 6.65 | .75 |
| Four forms on a sheet, one side, setting four | 7.65 | .75 |
| Side lines of figures adjusted to ruled lines will add \$1.50 to first 100 copies. | | |

| | | |
|---|------|-----|
| Half-Sheet of Cap (16-lb. paper, 30c. per hundred ; ruling, \$1.00). | | |
| One form on a sheet | 4.10 | .55 |
| Same, backed, with one fold | 5.85 | .65 |
| Backed with same form | 4.30 | .65 |
| Two forms on a sheet, one side, setting two | 5.50 | .60 |
| Three forms on a sheet, setting three | 6.50 | .60 |
| Four forms on a sheet, setting four | 7.50 | .60 |

| | | |
|--|------|-----|
| Quarter-Sheet Folio (24-lb. paper, 23c. per hundred). | | |
| One form on a sheet | 3.95 | .50 |
| Backed, with one fold | 5.50 | .40 |
| Backed with same form | 4.15 | .60 |

| | | |
|---|------|-----|
| Quarter-Sheet Cap (16-lb. paper, 15c. per hundred ; ruling, \$1.00). | | |
| One form on a sheet, one side | 3.75 | .40 |
| Same, backed, with one fold | 5.50 | .40 |
| Backed with same form | 3.95 | .50 |

| | | |
|--|------|-----|
| Eighth Sheet of Folio (24-lb. paper, 12c. per hundred). | | |
| One form on a sheet, one side | 3.45 | .30 |
| Backed, one fold | 4.80 | .35 |
| Same form on both sides | 3.60 | .35 |

Blanks without ruling, omit prices for ruling as given above.

BANKERS' DEPOSIT BOOKS.

With printing on cover and on second and third pages inside.

| | | |
|--|-----------|-----------|
| Press or tag-board covers, 3¾ × 5½ inches. | FIRST 100 | ADDED 100 |
| 6 leaves | \$3.50 | \$2.00 |
| 12 leaves | 4.50 | 3.00 |
| 24 leaves | 5.50 | 4.00 |
| Press or tag-board covers, 4¼ × 6¾ inches. | | |
| 12 leaves | 5.00 | 3.40 |
| 24 leaves | 6.00 | 4.50 |
| Leather covers, 3¾ × 5½ inches. | | |
| 24 leaves | 10.00 | 8.00 |
| Leather covers, 4¼ × 6¾ inches. | | |
| 24 leaves | 14.00 | 9.00 |
| Leather covers, 3¼ × 7¾ inches. | | |
| 24 leaves | 14.00 | 9.00 |

Interleaved books—the large sizes will be \$3.00 extra for each 100 books.

BLANK BOOKS.

In handling blank books, printers should abandon the quire figuring of 80 pages, and substitute 100 pages.

Half binding may be either tight or loose smooth back, with paper or cloth sides and leather corners, usually colored leather.

Three-quarter binding is first-class in every respect as to stock, usually russia back and corners, finished with raised cords or hubs and cloth sides.

Full end and band binding and extra russia ends and bands, full gilt back, are well-known to the trade and need not be described. The figures here submitted are for the best of their class as to binding.

FLAT CAP. 18-LB. WESTON OR BROWN.

| | | | | |
|--|------------------|--------------------|-----------------|------------------|
| Books of 400 pages—5 quires. | HALF BINDING. | THREE- QUARTER. | FULL E. & B. | EXTRA RUSSIA. |
| Ledgers, journals and blank books—paper, \$1.25; ruling, \$2.00 | \$5.20 | \$5.90 | \$8.20 | \$9.70 |
| Added books in same order | 3.50 | 4.20 | 6.50 | 8.00 |
| Added 100 pages | .50 | .50 | .50 | .50 |
| Books with printed headings—ruling, \$2.50; composition, \$2.00; presswork, \$1.30 | 9.00 | 9.70 | 12.00 | 13.50 |
| Added books in same order | 3.90 | 4.60 | 6.90 | 8.40 |
| Added 100 pages | .60 | .60 | .60 | .60 |
| Books with full-page printing; border ruling, \$1.50; composition, \$3.00; presswork, \$1.50 | 9.35 | 10.05 | 12.35 | 13.85 |
| Added books in same order | 3.80 | 4.50 | 6.80 | 8.30 |
| Added 100 pages | .65 | .65 | .65 | .65 |

If two pages are printed full, add \$1.50 to each book.

Omitting border on full-page printed books will take off \$1.50 from first book and 20c. from additional books.

For less number of pages, use the same figures as for additional 100 pages.

20-lb. best ledger will add 10c. for each 100 pages.

Index in front, add \$1.25 to each book, including paper. Index through, add \$2.00 to each book. Canvas cover, add \$1.00.

Printed numbered lines down one page, add \$1.00 to first book; and if on both pages, add \$2.00 for first book.

Patent back, \$1.25 extra.

All additions to be added to gross figures.

DEMY. 28-LB. WESTON OR BROWN.**Books of 400 pages—5 quires.**

| | HALF BINDING. | THREE- QUARTER. | FULL E. & B. | EXTRA RUSSIA. |
|--|------------------|--------------------|-----------------|------------------|
| Ledgers, journals and blank books—paper, \$2.15; ruling, \$1.85 . | \$6.15 | \$8.05 | \$9.45 | \$10.90 |
| Added books in same order | 4.40 | 6.30 | 7.70 | 9.15 |
| Added 100 pages | .80 | .80 | .80 | .80 |
| Books with printed headings—ruling, \$2.50; composition, presswork, \$1.30 | 10.10 | 12.00 | 13.40 | 14.85 |
| Added books in same order | 5.00 | 6.90 | 8.30 | 9.75 |
| Added 100 pages | .90 | .90 | .90 | .90 |
| Books with full-page printing—border ruling, \$1.50; composition, \$4.00; presswork, \$1.50 | 11.15 | 13.05 | 14.45 | 15.90 |
| Added books in same order | 5.00 | 6.90 | 8.30 | 9.75 |
| Added 100 pages | .90 | .90 | .90 | .90 |

If two pages are printed full, add \$1.50 to each book.

Omitting border on full-page printed books will take off \$1.50 from first book and 40c. from additional books.

For less number of pages, use the same figures as for additional 100 pages.

30-lb. best ledger will add 10c. for each 100 pages.

Index in front, add \$1.50 to each book, including paper. Index through, add \$2.00 to each book. Canvas cover, add \$1.25. Patent back, \$1.50 extra.

Printed numbered lines down one page, add \$1.50 to first book; and if on both pages, add \$2.50 for first book.

All additions to be added to gross figures.

MEDIUM. 36-LB. WESTON OR BROWN.**Books of 400 pages—5 quires.**

| | HALF BINDING. | THREE- QUARTER. | FULL E. & B. | EXTRA RUSSIA. |
|---|------------------|--------------------|-----------------|------------------|
| Ledgers, journals and blank books—paper, \$3.00; ruling, \$2.75 . | \$8.25 | \$10.35 | \$11.85 | \$12.45 |
| Added books in same order | 5.85 | 7.85 | 9.35 | 10.95 |
| Added 100 pages | 1.15 | 1.15 | 1.15 | 1.15 |
| Books with printed headings—ruling, \$2.75; composition, \$3.00; presswork, \$1.75 | 12.90 | 15.00 | 16.50 | 18.10 |
| Added books in same order | 6.55 | 8.65 | 10.15 | 11.35 |
| Added 100 pages | 1.25 | 1.25 | 1.25 | 1.25 |
| Books with full-page printing—border, \$1.75; composition, \$5.00; presswork, \$2.00 | 13.40 | 15.50 | 17.00 | 18.60 |
| Added books in same order | 6.55 | 8.65 | 10.15 | 11.35 |
| Added 100 pages | 1.25 | 1.25 | 1.25 | 1.25 |

If two pages are printed full, add \$2.00 to each book.

Omitting border on full-page printed books will take off \$1.75 from first book and 40c. from additional books.

For less number of pages, use the same figures as for additional 100 pages.

40-lb. best ledger will add 20c. for each 100 pages.

Index in front, add \$1.50 to each book, including paper. Index through, add \$2.00 to each book. Canvas cover, add \$1.50. Patent backs, \$2.00 extra.

Printed numbered lines down one page, add \$2.00 to first book; and if on both pages, add \$3.00 for first book.

All additions to be added to gross figures.

DOUBLE CAP. 36-LB. WESTON OR BROWN.**Books of 400 pages—5 quires.**

| | HALF BINDING. | THREE- QUARTER. | FULL E. & B. | EXTRA RUSSIA. |
|---|------------------|--------------------|-----------------|------------------|
| Ledgers, journals and blank books—paper, \$2.50; ruling, \$2.75 . | \$8.00 | \$10.20 | \$11.70 | \$13.95 |
| Added books in same order | 6.10 | 8.30 | 9.80 | 12.05 |
| Added 100 pages | 1.05 | 1.05 | 1.05 | 1.05 |
| Books with printed headings—ruling, \$2.75; composition, \$4.00; presswork, \$1.75 | 13.65 | 14.85 | 17.35 | 19.60 |
| Added books in same order | 6.70 | 8.90 | 10.40 | 12.65 |
| Added 100 pages | 1.15 | 1.15 | 1.15 | 1.15 |
| Books with full-page printing—ruling, \$2.00; composition, \$6.00; presswork, \$2.00 | 14.90 | 17.10 | 18.60 | 20.85 |
| Added books in same order | 6.90 | 9.10 | 10.60 | 12.85 |
| Added 100 pages | 1.20 | 1.20 | 1.20 | 1.20 |

If two pages are printed full, add \$2.00 to each book.

Omitting border on full-page printed books will take off \$2.00 from first book and 40c. from additional books.

For less number of pages, use the same figures as for additional 100 pages.

40-lb. best ledger will add 15c. for each 100 pages.

Index in front, add \$1.50 to each book, including paper. Index through, add \$2.00 to each book. Canvas cover, add \$2.00. Patent back, \$2.00 extra.

Printed numbered lines down one page, add \$2.00 to first book ; and if on both pages, add \$3.00 for first book.

All additions to be added to gross figures.

ROYAL. 44=LB. WESTON OR BROWN.

Use double cap table, and add \$1.20 to each book of 400 pages, and 30c. for added 100 pages.

SUPER=ROYAL. 54=LB. WESTON OR BROWN.

Books of 400 pages—5 quires.

| | HALF BINDING. | THREE- QUARTER. | FULL, E. & B. | EXTRA RUSSIA. |
|---|------------------|--------------------|------------------|------------------|
| Ledgers, journals and blank books—paper, \$5.00; ruling, \$3.50 | \$11.10 | \$13.50 | \$15.20 | \$17.65 |
| Added books in same order | 8.60 | 11.00 | 12.70 | 15.15 |
| Added 100 pages | 1.70 | 1.70 | 1.70 | 1.70 |
| Books with printed headings—ruling, \$3.50; composition, \$5.00; presswork, \$2.00 | 18.10 | 20.50 | 22.20 | 24.65 |
| Added books in same order | 9.40 | 11.80 | 13.50 | 15.95 |
| Added 100 pages | 1.90 | 1.90 | 1.90 | 1.90 |
| Books with full-page printing—ruling, \$3.50; composition, \$9.00; presswork, \$3.00 | 23.10 | 25.50 | 27.20 | 29.65 |
| Added books in same order | 9.60 | 12.00 | 13.70 | 16.15 |
| Added 100 pages | 2.00 | 2.00 | 2.00 | 2.00 |

If two pages are printed full, add \$3.00 to each book.

Omitting border on full-page printed books will take off \$3.50 from first book and 50c. from additional books.

For less number of pages, use the same figures as for additional 100 pages.

Index in front, add \$2.00 to each book, including paper. Index through, add \$2.00 to each book. Canvas cover, add \$3.00. Patent back, \$2.50 extra.

Printed numbered lines down one page, add \$2.00 to first book ; and if on both pages, add \$3.00 for first book.

All additions to be added to gross figures.

DOUBLE DEMY. 56=LB. WESTON OR BROWN.

Books of 400 pages—5 quires.

| | HALF BINDING. | THREE- QUARTER. | FULL E. & B. | EXTRA RUSSIA. |
|---|------------------|--------------------|-----------------|------------------|
| Ledgers, journals and blank books—paper, \$4.25; ruling, \$3.50 | \$11.35 | \$14.35 | \$16.45 | \$19.55 |
| Added books in same order | 8.50 | 11.50 | 13.60 | 16.70 |
| Added 100 pages | 1.55 | 1.55 | 1.55 | 1.55 |
| Books with printed headings—ruling, \$3.50; composition, \$5.00; presswork, \$2.00 | 18.35 | 21.35 | 23.45 | 26.55 |
| Added books in same order | 9.10 | 12.10 | 14.20 | 17.30 |
| Added 100 pages | 1.70 | 1.70 | 1.70 | 1.70 |
| Books with full-page printing—ruling, \$3.50; composition, \$9.00; presswork, \$3.00 | 25.35 | 29.35 | 31.45 | 34.55 |
| Added books in same order | 9.30 | 12.30 | 14.40 | 17.50 |
| Added 100 pages | 1.80 | 1.80 | 1.80 | 1.80 |

If two pages are printed full, add \$3.00 to each book.

Omitting border on full-page printed books will take off \$3.50 from first book and 50c. from additional books.

For less number of pages, use the same figures as for additional 100 pages.

Index in front, add \$2.00 to each book, including paper. Index through, add \$2.00 to each book. Canvas cover, add \$3.00. Patent back, \$2.50 extra.

Printed numbered lines down one page, add \$2.00 to first book ; and if on both pages, add \$3.00 for first book.

All additions to be added to gross figures.

DOUBLE MEDIUM. 72-LB. WESTON OR BROWN.

Books of 400 pages—5 quires.

| | HALF BINDING. | THREE QUARTER. | FULL E. & B. | EXTRA RUSSIA. |
|--|------------------|-------------------|-----------------|------------------|
| Ledgers, journals and blank books—paper, \$6.00; ruling, \$4.00 | \$13.90 | \$17.50 | \$20.00 | \$23.75 |
| Added books in same order | 10.90 | 14.50 | 17.00 | 20.75 |
| Added 100 pages | 2.00 | 2.00 | 2.00 | 2.00 |
| Books with printed headings—ruling, \$4.00; composition, \$6.00; presswork, \$2.00 | 21.90 | 25.50 | 28.00 | 31.75 |
| Added books in same order | 11.50 | 15.10 | 17.60 | 21.35 |
| Added 100 pages | 2.20 | 2.20 | 2.20 | 2.20 |
| Books with full-page printing—ruling, \$3.50; composition, \$10.00; presswork, \$3.00 | 26.40 | 30.00 | 32.50 | 36.25 |
| Added books in same order | 11.70 | 15.30 | 17.80 | 21.55 |
| Added 100 pages | 2.30 | 2.30 | 2.30 | 2.30 |

If two pages are printed full, add \$3.00 to each book.

Omitting border on full-page printed books will take off \$3.50 from first book and 50c. from additional books.

For less number of pages, use the same figures as for additional 100 pages.

Index in front, add \$2.50 to each book, including paper. Index through, add \$2.00 to each book. Canvas cover, add \$3.50. Patent back, \$2.50 extra.

Printed numbered lines down one page, add \$2.00 to first book; and if on both pages, add \$3.00 for first book.

All additions to be added to gross figures.

BLANK BOOKS WITH STUBS OR DUPLICATES.

PRINTED, NUMBERED, PERFORATED AND BOUND.

Half-Bound, Double Cap (32-lb. \$1.20).

| | ONE BOOK 100 LEAVES. | ADDED 100 LEAVES IN SAME BOOK. |
|--|----------------------------|--------------------------------------|
| Two forms on a full sheet; composition, \$6.00, setting one. | | |
| In duplicate, 200 forms | \$12.50 | \$2.10 |
| Additional books | 4.90 | 2.10 |
| Three forms on a full sheet; composition, \$4.00, setting one. | | |
| In duplicate, 300 forms | 10.85 | 2.45 |
| Additional books | 5.25 | 2.45 |
| Four forms on a full sheet; composition, \$6.00, setting two. | | |
| In duplicate, 400 forms | 12.90 | 2.50 |
| Additional books | 5.30 | 2.50 |

Half-Bound, Folio Post (24-lb. 90c.).

| | | |
|--|-------|------|
| Two forms on a full sheet; composition, \$4.00, setting one. | | |
| In duplicate, 200 forms | 8.40 | 1.80 |
| Additional books | 3.30 | 1.80 |
| Three forms on a full sheet; composition, \$3.00, setting one. | | |
| In duplicate, 300 forms | 7.75 | 2.15 |
| Additional books | 3.65 | 2.15 |
| Four forms on a full sheet; composition, \$4.00, setting two. | | |
| In duplicate, 400 forms | 8.80 | 2.20 |
| Additional books | 3.70 | 2.20 |
| Five forms on a full sheet. | | |
| In duplicate, 500 forms | 10.00 | 2.40 |
| Additional books | 3.90 | 2.40 |
| Six forms on a full sheet. | | |
| In duplicate, 600 forms | 10.20 | 2.50 |
| Additional books | 4.10 | 2.50 |

Half-Bound, Flat Cap (16-lb., 60c.).

| | | |
|--|------|------|
| Two forms on a full sheet; composition, \$3.00, setting one. | | |
| In duplicate, 200 forms | 7.40 | 1.50 |
| Additional books | 2.80 | 1.50 |
| Three forms on a full sheet; composition, \$2.00, setting one. | | |
| In duplicate, 300 forms | 6.75 | 1.85 |
| Additional books | 3.15 | 1.85 |
| Four forms on a full sheet; composition, \$3.00, setting two. | | |
| In duplicate, 400 forms | 7.80 | 1.90 |
| Additional books | 3.20 | 1.90 |
| Five forms on a full sheet. | | |
| In duplicate, 500 forms | 9.00 | 2.10 |
| Additional books | 3.40 | 2.10 |

BLANK BOOKS WITH STUBS OR DUPLICATES.

PRINTED, NUMBERED, PERFORATED AND BOUND—*Continued.*

| | ONE BOOK 100 LEAVES. | ADDED 100 LEAVES IN SAME BOOK. |
|---|----------------------------|--------------------------------------|
| Half-Bound, Half-Folio Post (24-lb., 45c.). | | |
| Two forms on a half sheet; composition, \$2.50, setting one. | | |
| In duplicate, 200 forms | \$6.05 | \$1.35 |
| Additional books | 2.45 | 1.35 |
| Three forms on a half sheet; composition, \$2.00, setting one. | | |
| In duplicate, 300 forms | 5.90 | 1.70 |
| Additional books | 2.80 | 1.70 |
| Four forms on a half sheet; composition, \$2.50, setting two. | | |
| In duplicate, 400 forms | 6.45 | 1.75 |
| Additional books | 2.85 | 1.75 |
| Five forms on a half sheet; composition, \$3.50, setting three. | | |
| In duplicate, 500 forms | 7.90 | 2.20 |
| Additional books | 3.30 | 2.20 |
| Six forms on a half sheet; composition, \$3.50, setting three. | | |
| In duplicate, 600 forms | 7.85 | 2.05 |
| Additional books | 3.15 | 2.05 |
| Half-Bound, Half Cap (16-lb., 30c.). | | |
| One form in duplicate | 6.00 | .80 |
| Additional books | 1.90 | .80 |
| Two forms on a half-sheet. | | |
| In duplicate, 200 forms | 6.70 | 1.00 |
| Additional books | 2.10 | 1.00 |
| Three forms on a half sheet. | | |
| In duplicate, 300 forms | 6.90 | 1.20 |
| Additional books | 2.30 | 1.20 |
| Four forms on a half sheet. | | |
| In duplicate, 400 forms | 7.10 | 1.30 |
| Additional books | 2.50 | 1.30 |
| Five forms on a half sheet. | | |
| In duplicate, 500 forms | 7.30 | 1.40 |
| Additional books | 2.70 | 1.40 |
| Half-Bound, Quarter-Sheet Folio (24-lb., 23c.). | | |
| One form on a quarter sheet. | | |
| In duplicate, 100 forms | 5.90 | .75 |
| Additional books | 1.80 | .75 |
| Two forms on a quarter sheet. | | |
| In duplicate, 200 forms | 6.60 | .90 |
| Additional books | 2.00 | .90 |
| Three forms on a quarter sheet. | | |
| In duplicate, 300 forms | 6.80 | 1.15 |
| Additional books | 2.20 | 1.15 |
| Half-Bound, Quarter-Sheet Cap (16-lb., 15c.). | | |
| Long form on a quarter sheet. | | |
| In duplicate, 100 forms | 4.10 | .60 |
| Additional books | 1.20 | .60 |
| Without perforating or numbering | 3.65 | .40 |
| Additional books | 1.00 | .40 |
| One form on a quarter sheet. | | |
| In duplicate, 100 forms | 4.60 | .55 |
| Additional books | 1.50 | .55 |
| Two forms on a quarter sheet. | | |
| In duplicate, 200 forms | 4.80 | .75 |
| Additional books | 1.65 | .75 |

Triplicate forms, add for extra numbers and perforations on each book of 100 forms, 15 cents; 200 forms, 20 cents; 300 forms, 25 cents; 400 forms, 30 cents; 500 forms, 35 cents; 600 forms, 40 cents.

Check binding will reduce the figures on any one book \$1.00. Duck binding will reduce the figures on any one book 50c.

If not numbered, reduce 10c. for every 100 forms.

COMMISSIONS SALES ACCOUNTS.

On 4s of 16-lb. cap, at 12c. ; ruled to order.
 100 copies, \$3.50; 1,000 copies, \$5.10. Added 1,000 copies, \$2.60.

On 4s of 24-lb. folio, at 12c. ; ruled to order.
 100 copies, \$2.70; 500 copies, \$4.10; 1,000 copies, \$6.00. Added 1,000 copies, \$3.60.

GUARD BOOKS OR PLAT BOOKS.

Quarter medium, 150 leaves, manilla paper, half-bound, paper sides, \$2.50.
 Half medium, 200 leaves, \$3.00.
 Full medium size, 200 leaves, \$5.00.
 Large sizes, \$6.00 to \$10.00.

NUMBERING AND PERFORATING.

Consecutive numbering on cards, checks, deposit certificates, etc. :

500 numbers \$0.40 | 1,000 numbers \$0.50
 Over 1000 numbers, 50c. per 1000.

Perforating in small quantities :

100 perforations \$0.20 | 1,000 perforations \$0.50
 500 perforations40 | Over 1,000, per thousand50

BINDING BLANK BOOKS WITHOUT THE RULING, PRINTING OR PAPER COUNTED IN.

400 pages—5 quires.

| | HALF BDG. | THREE- QUARTERS. | FULL E. & B. | EXTRA E. & B. |
|--------------------------------|--------------|---------------------|-----------------|------------------|
| Flat cap | \$1.60 | \$2.30 | \$4.60 | \$6.10 |
| Added 100 pages | .10 | .10 | .10 | .10 |
| Demy | 1.80 | 3.70 | 5.10 | 6.55 |
| Added 100 pages | .15 | .15 | .15 | .15 |
| Medium | 2.15 | 4.25 | 5.75 | 7.35 |
| Added 100 pages | .20 | .20 | .20 | .20 |
| Royal and double cap | 2.40 | 4.60 | 6.10 | 8.35 |
| Added 100 pages | .25 | .25 | .25 | .25 |
| Super royal | 2.60 | 5.00 | 6.70 | 9.15 |
| Added 100 pages | .25 | .25 | .25 | .25 |
| Double demy | 3.25 | 6.25 | 8.35 | 11.45 |
| Added 100 pages | .25 | .25 | .25 | .25 |
| Double medium | 3.90 | 7.50 | 10.00 | 13.75 |
| Added 100 pages | .25 | .25 | .25 | .25 |

RULING ON BLANKS.

Demy or smaller, under 20 down pens.

| | 100 | 250 | 500 | 1000 | ADDED 100 |
|----------------------|--------|--------|--------|--------|-----------|
| One run | \$0.90 | \$1.00 | \$1.10 | \$1.40 | \$0.05 |
| Two runs | 1.50 | 1.70 | 2.00 | 2.50 | .08 |
| Three runs | 2.00 | 2.25 | 2.75 | 3.25 | .12 |
| Four runs | 2.50 | 2.80 | 3.30 | 4.00 | .15 |

Double cap or smaller, under 40 down pens.

| | | | | | |
|----------------------|------|------|------|------|-----|
| One run | 1.00 | 1.25 | 1.60 | 2.00 | .06 |
| Two runs | 1.80 | 2.10 | 2.50 | 3.10 | .12 |
| Three runs | 2.50 | 2.85 | 3.50 | 4.25 | .15 |
| Four runs | 3.00 | 3.50 | 4.10 | 5.00 | .18 |

Double demy or smaller, under 60 down pens.

| | | | | | |
|----------------------|------|------|------|------|-----|
| One run | 1.50 | 2.00 | 2.75 | 3.25 | .08 |
| Two runs | 2.25 | 2.75 | 3.50 | 4.25 | .16 |
| Three runs | 3.00 | 3.50 | 4.25 | 5.25 | .20 |
| Four runs | 3.75 | 4.25 | 5.00 | 6.25 | .25 |

Double medium or smaller, under 80 down pens.

| | | | | | |
|----------------------|------|------|------|------|-----|
| One run | 2.00 | 2.50 | 3.00 | 3.75 | .10 |
| Two runs | 3.00 | 3.50 | 4.00 | 5.00 | .20 |
| Three runs | 4.00 | 4.50 | 5.00 | 6.25 | .25 |
| Four runs | 5.00 | 5.50 | 6.00 | 7.50 | .30 |

JOB BINDING, WITHOUT NUMBERING AND PERFORATING.

Quarter cap or up to 4 x 12.

| | CHECK. | DUCK. | HF. BDG. |
|--|--------|--------|----------|
| Single books of 100 leaves or less | \$0.15 | \$0.40 | \$0.75 |
| Additional books in same order | .10 | .30 | .65 |
| Twenty books or over, per book | .10 | .25 | .60 |
| Books of 50 leaves only, in orders over 20, per book | .08 | .20 | .50 |

Quarter folio or up to 5 1/2 x 17.

| | | | |
|--|-----|-----|------|
| Single books of 100 leaves or less | .25 | .50 | .90 |
| Additional books in same order | .20 | .40 | .80 |
| Twenty books or over, per book | .15 | .35 | .75 |
| Single books of 200 leaves, or over 100 leaves | .30 | .60 | 1.00 |
| Additional books in same order | .25 | .50 | .90 |
| Twenty books or over, per book | .20 | .40 | .80 |

Half sheet cap or up to 5 1/3 x 22.

| | | | |
|--|-----|-----|------|
| Single books of 100 leaves or less | .30 | .60 | 1.10 |
| Additional books in same order | .25 | .50 | .90 |
| Twenty books or over, per book | .20 | .40 | .80 |
| Single books of 200 leaves, or over 100 leaves | .35 | .65 | 1.10 |
| Additional books in same order | .30 | .55 | 1.00 |
| Twenty books or over, per book | .25 | .40 | .90 |

Half sheet folio, demy or medium, either way.

| | | | |
|--|-----|-----|------|
| Single books of 100 leaves or less | .40 | .70 | 1.10 |
| Additional books in same order | .30 | .60 | 1.00 |
| Twenty books or over, per book | .25 | .45 | .75 |
| Single books of 200 leaves, or over 100 leaves | .45 | .75 | 1.15 |
| Additional books in same order | .35 | .65 | 1.05 |
| Twenty books or over, per book | .30 | .50 | .80 |

Full sheet cap, not folded.

| | | | |
|--|-----|-----|------|
| Single books of 100 leaves or less | .45 | .75 | 1.15 |
| Additional books in same order | .35 | .65 | 1.05 |
| Twenty books or over, per book | .30 | .50 | .80 |
| Single books of 200 leaves, or over 100 leaves | .50 | .80 | 1.20 |
| Additional books in same order | .40 | .70 | 1.10 |
| Twenty books or over, per book | .35 | .55 | .85 |

Perforating, 50c. per 1000 perforations.

Numbering, 50c. per 1000 numbers.

PAMPHLET BINDING.

| | WITHOUT COVER. | | WITH COVER. | |
|---|--|--------------|--|--------------|
| | SADDLE STITCH. | SIDE STITCH. | SADDLE STITCH. | SIDE STITCH. |
| 8 pages, 1 form, per thousand copies | \$1.30 | \$1.60 | \$2.00 | \$3.80 |
| 12 pages, 1 form, per thousand copies | 1.40 | 1.70 | 2.20 | 4.00 |
| 16 pages, 1 form, per thousand copies | 1.50 | 1.80 | 2.20 | 4.00 |
| 16 pages, 2 forms, per thousand copies | 1.75 | 2.00 | 2.50 | 4.30 |
| 24 pages, 2 forms, per thousand copies | 2.00 | 2.30 | 2.75 | 4.50 |
| 24 pages, 3 forms, per thousand copies | 2.25 | 2.60 | 3.00 | 4.80 |
| 32 pages, 1 form, per thousand copies | 2.00 | 2.30 | 2.50 | 4.50 |
| 32 pages, 2 forms, per thousand copies | 2.25 | 2.60 | 3.00 | 4.80 |
| | WITH COVER. | | WITH COVER | |
| | SIDE STITCH. | | SIDE STITCH. | |
| 32 pages, 3 forms, per thousand copies . . . \$5.00 | 56 pages, 4 forms, per thousand copies . . . | \$5.75 | 56 pages, 5 forms, per thousand copies . . . | 6.00 |
| 32 pages, 4 forms, per thousand copies . . . 5.00 | 56 pages, 5 forms, per thousand copies . . . | 6.25 | 56 pages, 6 forms, per thousand copies . . . | 6.25 |
| 40 pages, 2 forms, per thousand copies . . . 4.75 | 56 pages, 6 forms, per thousand copies . . . | 6.50 | 56 pages, 7 forms, per thousand copies . . . | 6.50 |
| 40 pages, 3 forms, per thousand copies . . . 5.00 | 64 pages, 2 forms, per thousand copies . . . | 5.50 | 64 pages, 3 forms, per thousand copies . . . | 5.75 |
| 40 pages, 4 forms, per thousand copies . . . 5.25 | 64 pages, 3 forms, per thousand copies . . . | 6.00 | 64 pages, 4 forms, per thousand copies . . . | 6.00 |
| 40 pages, 5 forms, per thousand copies . . . 5.50 | 64 pages, 4 forms, per thousand copies . . . | 6.25 | 64 pages, 5 forms, per thousand copies . . . | 6.50 |
| 48 pages, 2 forms, per thousand copies . . . 5.00 | 64 pages, 5 forms, per thousand copies . . . | 6.50 | 64 pages, 6 forms, per thousand copies . . . | 6.75 |
| 48 pages, 3 forms, per thousand copies . . . 5.25 | 64 pages, 6 forms, per thousand copies . . . | 7.00 | 64 pages, 7 forms, per thousand copies . . . | 7.00 |
| 48 pages, 4 forms, per thousand copies . . . 5.50 | 64 pages, 7 forms, per thousand copies . . . | 7.50 | 64 pages, 8 forms, per thousand copies . . . | 7.50 |
| 48 pages, 5 forms, per thousand copies . . . 5.75 | 64 pages, 8 forms, per thousand copies . . . | 7.50 | 72 pages, 9 forms, per thousand copies . . . | 7.50 |
| 48 pages, 6 forms, per thousand copies . . . 6.00 | 72 pages, 9 forms, per thousand copies . . . | 7.50 | | |
| 56 pages, 3 forms, per thousand copies . . . 5.50 | | | | |

Without cover, deduct \$1.50. Every added 8-page form, 50c.; every added 16-page form, 75c. In orders less than 1000 use the proportionate value, adding one-tenth On quarto forms add 10 per cent.

For cloth backs, add \$3.00 and for quarto, \$5.00 per 1000 copies. For holes punched in for strings, \$1.50 per 1000.

BINDING YEARLY PUBLICATIONS.

The prices herewith are *net figures* for single books, or two of a kind. For three or more volumes of same finish, 5 per cent. reduction may be made. For ten or more volumes of same finish, a 10 per cent. reduction can be made.

| STYLE OF BINDING. | 5 x 8 | 6 x 9 | 8 x 11 | 11 x 16 | |
|--|------------------------------|---------------------------------|--------------------------------|--|--------------|
| | UNDER 800 PP. | SIX MONTHS. | SIX MONTHS. | SIX MONTHS. | ONE YEAR. |
| | NOVELS, LIBRARY BOOKS. | SUCH AS CENTURY, HARPERS' | SUCH AS LESLIE'S MONTHLY | SUCH AS HARPERS' WEEKLY, YOUTHS' COMPANION | |
| Full cloth, stiff board sides | \$0.65 | \$0.75 | \$1.00 | \$1.25 | \$1.50 |
| Half sheep or roan, sprinkled edges, cloth or paper sides | .75 | .90 | 1.25 | 2.00 | 2.50 |
| Full sheep or roan, sprinkled edges | .85 | 1.00 | 1.50 | 2.00 | 2.50 |
| Half sprinkled sheep, library style, cloth sides, sprinkled edges | .90 | 1.15 | 1.65 | 2.25 | 2.75 |
| Full sprinkled sheep, sprinkled edges | .95 | 1.25 | 1.75 | 2.50 | 3.00 |
| Full sprinkled sheep, marbled edges | 1.05 | 1.35 | 1.90 | 2.75 | 3.25 |
| Half imitation morocco, cloth or paper sides, sprinkled or marbled edges | 1.10 | 1.25 | 1.75 | 3.00 | 3.50 |
| Half genuine morocco, marbled edges | 1.25 | 1.50 | 2.25 | 3.50 | 4.00 |
| Gilt edge extra on any book | .50 | .75 | 1.00 | 1.25 | 1.50 |

RE-BINDING FOR PUBLIC LIBRARIES, SCHOOLS, ETC.

| STYLE OF BINDING. | 24MO. | 16MO. | 12MO. | 8VO. | 4TO. |
|---|--------|--------|--------|--------|--------|
| Half black leather (roan), cloth sides, no leather corners, gilt lettering on back, cloth joint | \$0.40 | \$0.40 | \$0.50 | \$0.60 | \$1.25 |
| Half sheep leather, cloth sides, no corners, ink lettering on back, cloth joint | .30 | .30 | .40 | .50 | 1.10 |

BINDING SHEET MUSIC.

| | PER VOL. |
|---|----------|
| Half morocco, cloth or paper sides | \$2.25 |
| Half library roan, cloth or paper sides | 1.75 |
| Full morocco, flexible | 3.00 |
| Full roan or buffing, flexible | 2.00 |
| Full cloth, flexible or stiff | 1.50 |

BINDING NEWSPAPER FILES.

| | PER VOL. |
|--|----------|
| One-half canvas back and paper board sides | \$1.50 |
| One-half roan, paper sides | 2.00 |

PART XXII.

Condensed Price List
AND
Telegraph Code

CONDENSED PRICE LIST

AND TELEGRAPH CODE

For Telegraph Code for Body-Letter, see pages 1182 and 1183

For the convenience of customers requiring Type and Brass Rule in a hurry, when messages exceed the ten-word limit, a telegraph Code Word is printed opposite each important item in the following Condensed Price List. The use of a Code Word opposite the name of a series indicates that the entire series is wanted. The use of a Code Word opposite any one size of a series indicates that a font of that size only is wanted. If part of a series is wanted, the Code Word for the series may be telegraphed, followed by the word "except" and the Code Words opposite the sizes not required, thus: "Abeltree, except Aberuncate, Abetting," will indicate that the entire Alaskan series with the exception of the 18 point and 48 point size is ordered.

Acanthine Florets. E
Per font.....\$2 00... *Abderites*

ACORN INITIALS (see Initials).

Advertising Figures. F

| | | |
|---------------|-----------|---------|
| No. 1821..... | per font. | 1 00... |
| 1822..... | | 0 75... |
| 1823..... | | 0 50... |
| 1825..... | | 1 00... |
| 1826..... | | 1 00... |
| 1830..... | | 1 00... |
| 2421..... | | 1 25... |
| 2422..... | | 1 00... |
| 2423..... | | 0 75... |
| 2425..... | | 1 30... |
| 2430..... | | 1 25... |
| 3021..... | | 1 90... |
| 3022..... | | 1 35... |
| 3023..... | | 1 00... |
| 3025..... | | 1 95... |
| 3036..... | | 1 75... |
| 3621..... | | 2 30... |
| 3622..... | | 2 90... |
| 3623..... | | 1 40... |
| 3625..... | | 2 50... |
| 3626..... | | 2 60... |
| 3630..... | | 2 20... |
| 4221..... | | 3 15... |
| 4222..... | | 2 40... |
| 4223..... | | 1 80... |
| 4225..... | | 3 30... |
| 4226..... | | 3 50... |
| 4230..... | | 3 00... |
| 4821..... | | 3 65... |
| 4822..... | | 3 00... |
| 4823..... | | 2 15... |
| 4825..... | | 3 90... |
| 4826..... | | 4 00... |
| 4830..... | | 3 75... |
| 5421..... | | 4 70... |
| 5422..... | | 3 80... |
| 5423..... | | 2 80... |
| 5425..... | | 5 00... |
| 5426..... | | 5 20... |
| 5430..... | | 4 65... |
| 6021..... | | 5 50... |
| 6022..... | | 4 45... |
| 6023..... | | 3 25... |
| 6025..... | | 5 00... |
| 6026..... | | 5 90... |
| 6030..... | | 5 25... |

Advertising Rules.

Prices are for columnus 15 Pica ems wide and under. For each additional width of column add 50 per cent.

| | | |
|---------------|----------------|-------|
| No. 203E..... | single column, | 04... |
| 219E..... | | 04... |
| 235E..... | | 05... |
| 236E..... | | 06... |
| 237E..... | | 06... |
| 273E..... | | 06... |
| 274E..... | | 06... |
| 275E..... | | 06... |
| 292E..... | | 06... |
| 293E..... | | 06... |
| 294E..... | | 06... |
| 295½E..... | | 06... |
| 296E..... | | 06... |
| 364E..... | | 05... |
| 365E..... | | 05... |
| 366E..... | | 05... |

Alaskan. E

| | | | |
|-----------|----------|-----------|-------------------|
| 6 Pt..... | 24A..... | \$1 50... | <i>Abeltree</i> |
| 8..... | 16A..... | 1 70... | <i>Abequerons</i> |
| 10..... | 12A..... | 1 70... | <i>Aberdevine</i> |
| 12..... | 10A..... | 2 05... | <i>Aberrant</i> |
| 18..... | 8A..... | 3 65... | <i>Aberration</i> |
| 24..... | 6A..... | 4 50... | <i>Aberuncate</i> |
| 36..... | 4A..... | 6 00... | <i>Abel</i> |
| 48..... | 3A..... | 7 30... | <i>Abetted</i> |
| | | | <i>Abetting</i> |

Alfereta. F

| | | | |
|------------|------------------------|---------|--------------------|
| 12 Pt..... | 8A \$1.00, 30a \$1.75. | 2 75... | <i>Ab blaze</i> |
| 18..... | 8A 1.85, 16a 1.65. | 3 50... | <i>Abtebodied</i> |
| 24..... | 6A 2.50, 12a 2.00. | 4 50... | <i>Abtepsy</i> |
| 30..... | 5A 2.80, 10a 2.45. | 5 25... | <i>Abtlets</i> |
| 36..... | 4A 3.15, 8a 2.85. | 6 00... | <i>Abtlocate</i> |
| | | | <i>Abtlocation</i> |

Algebraic Signs No. 150. F

| | | | |
|------------|-----------|---------|-------------------|
| 5½ Pt..... | per font, | 2 40... | <i>Abordant</i> |
| 6..... | | 2 00... | <i>Aborderez</i> |
| 7..... | | 1 80... | <i>Aborderons</i> |
| 8..... | | 1 60... | <i>Aboriginal</i> |
| 9..... | | 1 44... | <i>Aborigines</i> |
| 10..... | | 1 30... | <i>Abort</i> |
| 11..... | | 1 22... | <i>Abortions</i> |
| 12..... | | 1 16... | <i>Abortitic</i> |

Alpine. E

| | | | |
|------------|---------------------|---------|------------------|
| 12 Pt..... | 10A 1.15, 20a 1.20. | 2 35... | <i>Abrazitic</i> |
| 18..... | 8A 1.65, 16a 2.00. | 3 65... | <i>Abreast</i> |
| 24..... | 6A 2.15, 12a 2.20. | 4 35... | <i>Abreption</i> |
| 36..... | 4A 3.15, 8a 2.65. | 5 80... | <i>Abreuveus</i> |

American Script. F

| | | | |
|------------|---------------------|----------|---------------------|
| 12 Pt..... | 10A 2.75, 32a 2.25. | 5 00... | <i>Abstaining</i> |
| | 5A 1.65, 16a 1.35. | 3 00... | <i>Abstainment</i> |
| 18..... | 9A 3.25, 24a 2.75. | 6 00... | <i>Abstemious</i> |
| | 5A 2.00, 12a 1.50. | 3 50... | <i>Abstemiously</i> |
| 24..... | 8A 3.75, 22a 3.25. | 7 00... | <i>Abstenaits</i> |
| | 4A 2.00, 11a 2.00. | 4 00... | <i>Abstenant</i> |
| 30..... | 7A 4.25, 20a 3.25. | 7 50... | <i>Abstentir</i> |
| | 3A 2.25, 10a 2.00. | 4 25... | <i>Abstention</i> |
| 36..... | 5A 4.50, 15a 3.50. | 8 00... | <i>Abstentious</i> |
| 48..... | 4A 5.25, 10a 3.75. | 9 00... | <i>Abster</i> |
| 60..... | 3A 6.50, 8a 3.50. | 10 00... | <i>Abstered</i> |
| | | | <i>Absterge</i> |

American Typewriter. D

| | | | |
|------------|---------------------|---------|------------------|
| 10 Pt..... | 1SA 1.50, 85a 3.50. | 5 00... | <i>Absterged</i> |
|------------|---------------------|---------|------------------|

Angular Quads. C

| | | | |
|--------------------|------------------|---------|---------------|
| Per font..... | | 1 50... | <i>Acacia</i> |
| 12, 18, 24 Pt..... | per set of four, | 20... | |
| 36..... | " " " " | 25... | |
| 48..... | " " " " | 30... | |
| 60..... | " " " " | 35... | |
| 72..... | " " " " | 40... | |

Antique No. 42. C

| | | | |
|------------|-------------------|----------|----------------|
| 60 Pt..... | 5A 9.10, 6a 6.50. | 15 60... | <i>Acmites</i> |
|------------|-------------------|----------|----------------|

Antique No. 124. E

| | | | |
|--------------------|---------------------|----------|-------------------|
| 5 Pt. on 6 Pt..... | 24A .85, 48a 1.00. | 1 85... | <i>Acrisly</i> |
| 6..... | 24A 1.10, 48a 1.25. | 2 35... | <i>Acritan</i> |
| 8..... | 24A 1.35, 48a 1.55. | 2 90... | <i>Acrotide</i> |
| 10..... | 18A 1.20, 36a 1.40. | 2 60... | <i>Acrobat</i> |
| 12..... | 18A 1.60, 36a 1.80. | 3 40... | <i>Acrobatic</i> |
| 18..... | 12A 1.85, 24a 2.15. | 4 00... | <i>Acrochord</i> |
| 24..... | 10A 2.25, 20a 2.55. | 4 80... | <i>Acrogen</i> |
| 30..... | 6A 2.20, 12a 2.35. | 4 55... | <i>Acrogenous</i> |
| 36..... | 5A 2.45, 10a 2.60. | 5 05... | <i>Acrolith</i> |
| 42..... | 4A 3.75, 8a 3.75. | 7 50... | <i>Acromion</i> |
| 48..... | 3A 4.35, 6a 4.05. | 8 40... | <i>Acronomyal</i> |
| *72..... | 3A 8.15, 4a 6.00. | 14 15... | <i>Acropolis</i> |
| | | | <i>Acrostic</i> |

Antique No. 125. E *Acrostiche*

| | | | | | | |
|------------|-----|---------|-----|----------|-----------|-------------------|
| 5½ Pt..... | 32A | \$1.30, | 64A | \$1.65.. | \$2 95... | <i>Acroterial</i> |
| 6..... | 24A | 1.05, | 48A | 1.25.. | 2 30... | <i>Acroterium</i> |
| 7..... | 24A | 1.00, | 48A | 1.25.. | 2 25... | <i>Acrotomous</i> |
| 8..... | 24A | 1.30, | 48A | 1.50.. | 2 80... | <i>Acteth</i> |
| 9..... | 24A | 1.40, | 48A | 1.65.. | 3 05... | <i>Acteurs</i> |
| 10..... | 24A | 1.40, | 48A | 1.65.. | 3 05... | <i>Acting</i> |
| 12..... | 18A | 1.55, | 36A | 1.65.. | 3 20... | <i>Acting</i> |
| 18..... | 12A | 2.05, | 24A | 2.40.. | 4 45... | <i>Actiniform</i> |
| 24..... | 8A | 2.15, | 16A | 2.55.. | 4 70... | <i>Actinoid</i> |
| 30..... | 6A | 2.70, | 12A | 3.10.. | 5 80... | <i>Actinolite</i> |
| 36..... | 5A | 3.75, | 10A | 4.15.. | 7 90... | <i>Actionable</i> |
| 48..... | 4A | 4.60, | 8A | 4.75.. | 9 35... | <i>Actionary</i> |

Antique No. 126. E *Actionists*

| | | | | | | |
|------------|-----|-------|-----|--------|---------|-------------------|
| 5½ Pt..... | 24A | .90, | 48A | 1.10.. | 2 00... | <i>Actionant</i> |
| 6..... | 24A | .90, | 48A | 1.25.. | 2 15... | <i>Actionner</i> |
| 8..... | 20A | 1.05, | 40A | 1.20.. | 2 25... | <i>Activate</i> |
| 9..... | 18A | 1.00, | 36A | 1.10.. | 2 10... | <i>Actively</i> |
| 10..... | 18A | 1.10, | 36A | 1.25.. | 2 35... | <i>Activement</i> |
| 11..... | 16A | 1.00, | 32A | 1.20.. | 2 20... | <i>Activeness</i> |
| 12..... | 16A | 1.15, | 32A | 1.35.. | 2 50... | <i>Activities</i> |
| 18..... | 12A | 1.65, | 24A | 1.95.. | 3 60... | <i>Actors</i> |
| 24..... | 10A | 2.35, | 20A | 2.60.. | 4 95... | <i>Actress</i> |
| 36..... | 6A | 2.50, | 12A | 3.20.. | 6 00... | <i>Actual</i> |

Antique No. 127. E *Actuality*

| | | | | | | |
|-----------|-----|-------|-----|--------|---------|------------------|
| 6 Pt..... | 24A | 1.05, | 48A | 1.25.. | 2 30... | <i>Actuaries</i> |
| 8..... | 24A | 1.20, | 48A | 1.50.. | 2 70... | <i>Actuated</i> |
| 9..... | 18A | .95, | 36A | 1.10.. | 2 05... | <i>Actuating</i> |
| 10..... | 18A | 1.25, | 36A | 1.45.. | 2 70... | <i>Actuators</i> |
| 11..... | 16A | 1.10, | 32A | 1.35.. | 2 45... | <i>Actuelle</i> |
| 12..... | 16A | 1.40, | 32A | 1.55.. | 2 95... | <i>Actuosity</i> |
| 18..... | 10A | 1.85, | 20A | 2.05.. | 3 90... | <i>Acture</i> |
| 24..... | 8A | 2.55, | 16A | 2.90.. | 5 45... | <i>Acution</i> |

Antique Cond. No. 36. B *Adepts*

| | | | | | | |
|----------------------|-----|-------|-----|--------|---------|-------------------|
| 8 Pt..... | 30A | 1.45, | 50A | 1.15.. | 2 60... | <i>Adequacy</i> |
| 10..... | 25A | 1.45, | 40A | 1.20.. | 2 65... | <i>Adequate</i> |
| 12..... | 20A | 1.50, | 30A | 1.10.. | 2 60... | <i>Adequation</i> |
| 14..... | 15A | 1.45, | 25A | 1.25.. | 2 70... | <i>Adherait</i> |
| 18..... | 15A | 1.80, | 25A | 1.65.. | 3 45... | <i>Adherasse</i> |
| 24..... | 12A | 2.25, | 20A | 1.70.. | 3 95... | <i>Adhered</i> |
| 30..... | 10A | 2.60, | 15A | 1.95.. | 4 55... | <i>Adherence</i> |
| 42..... | 6A | 2.95, | 10A | 2.30.. | 5 25... | <i>Adherently</i> |
| 44 Pt. on 48 Pt..... | 5A | 3.25, | 8A | 2.70.. | 5 95... | <i>Adhering</i> |
| 48..... | 5A | 4.10, | 10A | 4.15.. | 8 25... | <i>Adhesion</i> |
| 60..... | 4A | 5.85, | 6A | 4.00.. | 9 85... | <i>Adhesivety</i> |

Antique Cond. No. 116. D *Advertent*

| | | | | | | |
|------------|-----|-------|-----|--------|---------|------------------|
| 10 Pt..... | 24A | 1.35, | 50A | 1.35.. | 2 70... | <i>Advertise</i> |
| 12..... | 20A | 1.30, | 30A | 1.25.. | 2 55... | <i>Advisedly</i> |
| 14..... | 16A | 1.45, | 30A | 1.40.. | 2 85... | <i>Advising</i> |
| 18..... | 15A | 1.45, | 24A | 1.45.. | 2 90... | <i>Advisory</i> |

Antique Cond. No. 122. E *Advocacy*

| | | | | | | |
|-----------|-----|-------|-----|--------|----------|------------------|
| 6 Pt..... | 24A | .90, | 48A | 1.00.. | 1 90... | <i>Advocate</i> |
| 8..... | 24A | 1.10, | 48A | 1.25.. | 2 35... | <i>Advowson</i> |
| 10..... | 24A | 1.35, | 48A | 1.50.. | 2 85... | <i>Adze</i> |
| 12..... | 18A | 1.35, | 36A | 1.50.. | 2 85... | <i>Aerolite</i> |
| 18..... | 12A | 1.60, | 24A | 1.90.. | 3 50... | <i>Aeronaut</i> |
| 24..... | 10A | 1.70, | 20A | 1.95.. | 3 65... | <i>Afar</i> |
| 30..... | 8A | 2.05, | 16A | 2.60.. | 4 65... | <i>Afable</i> |
| 36..... | 6A | 2.45, | 12A | 3.00.. | 5 45... | <i>Affair</i> |
| 48..... | 4A | 2.75, | 8A | 2.75.. | 5 50... | <i>Affected</i> |
| 60..... | 3A | 3.50, | 6A | 3.75.. | 7 25... | <i>Affection</i> |
| 72..... | 3A | 5.15, | 5A | 4.85.. | 10 00... | <i>Afflanced</i> |

Antique Cond. No. 123. E *Affidavit*

| | | | | | | |
|-----------|-----|-------|-----|--------|---------|------------------|
| 8 Pt..... | 24A | .95, | 48A | 1.20.. | 2 15... | <i>Affiliate</i> |
| 10..... | 24A | 1.00, | 48A | 1.30.. | 2 30... | <i>Affinity</i> |
| 12..... | 18A | 1.05, | 36A | 1.25.. | 2 30... | <i>Affirm</i> |
| 14..... | 16A | 1.15, | 32A | 1.55.. | 2 70... | <i>Affirmant</i> |
| 16..... | 12A | 1.05, | 24A | 1.35.. | 2 40... | <i>Affix</i> |
| 18..... | 12A | 1.35, | 24A | 1.70.. | 3 05... | <i>Affixing</i> |
| 24..... | 12A | 1.80, | 24A | 2.40.. | 4 20... | <i>Afflict</i> |
| 30..... | 8A | 1.95, | 16A | 2.45.. | 4 40... | <i>Afflitive</i> |
| 42..... | 6A | 2.40, | 12A | 3.15.. | 5 55... | <i>Affluent</i> |
| 48..... | 4A | 2.65, | 8A | 3.10.. | 5 75... | <i>Afford</i> |
| 60..... | 3A | 3.15, | 6A | 3.40.. | 6 55... | <i>Affray</i> |

Antique Cond. No. 124. E *Affright*

| | | | | | | |
|-----------|-----|-------|-------|-------|---------|------------------|
| 8 Pt..... | 24A | | | | 1 00... | <i>Affront</i> |
| 10..... | 24A | | | | 1 25... | <i>Aforesaid</i> |
| 12..... | 24A | | | | 1 45... | <i>Afresh</i> |
| 14..... | 18A | | | | 1 40... | <i>Afternoon</i> |
| 16..... | 18A | | | | 1 75... | <i>Afterward</i> |
| 18..... | 16A | | | | 2 30... | <i>Aape</i> |

Antique Cond. No. 124—Continued.

| | | | | | | |
|------------|-----|-------|-------|-------|-----------|-----------------|
| 24 Pt..... | 12A | | | | \$2 40... | <i>Agaphite</i> |
| 36..... | 8A | | | | 2 55... | <i>Agaric</i> |
| 42..... | 6A | | | | 3 00... | <i>Agates</i> |
| 48..... | 5A | | | | 3 40... | <i>Agency</i> |
| 60..... | 4A | | | | 4 20... | <i>Agendum</i> |
| *72..... | 5A | | | | 8 35... | <i>Agenesia</i> |

Antique Cond. No. 152. F *Aggravate*

| | | | | | | |
|------------|-----|---------|-----|----------|---------|-------------------|
| 20 Pt..... | 12A | \$2.00, | 16A | \$1.50.. | 3 50... | <i>Aggravator</i> |
| 24..... | 10A | 2.10, | 14A | 1.90.. | 4 00... | <i>Aggrieved</i> |
| 30..... | 8A | 2.30, | 12A | 2.20.. | 4 50... | <i>Aghast</i> |
| 36..... | 6A | 2.50, | 10A | 2.50.. | 5 00... | <i>Agile</i> |

Antique Ext'd No. 120. E *Alternity*

| | | | | | | |
|-----------|-----|-------|-----|--------|---------|------------------|
| 5 Pt..... | 18A | 1.70, | 36A | 1.80.. | 3 50... | <i>Attimetry</i> |
| 6..... | 12A | 1.15, | 24A | 1.35.. | 2 50... | <i>Attitude</i> |
| 8..... | 12A | 1.40, | 24A | 1.80.. | 3 20... | <i>Abudel</i> |
| 10..... | 12A | 1.80, | 24A | 2.15.. | 3 95... | <i>Aluminar</i> |
| 12..... | 8A | 1.80, | 16A | 2.15.. | 3 95... | <i>Atveotar</i> |
| 18..... | 6A | 2.55, | 12A | 2.70.. | 5 25... | <i>Amalgam</i> |
| 24..... | 4A | 2.85, | 8A | 2.90.. | 5 75... | <i>Amaranth</i> |

Antique Ext'd No. 122. E *Amateur*

| | | | | | | |
|------------|-----|-------|-----|--------|---------|----------------|
| 10 Pt..... | 10A | 1.75, | 20A | 1.95.. | 3 70... | <i>Amative</i> |
| 12..... | 8A | 1.85, | 16A | 2.15.. | 4 00... | <i>Amatory</i> |
| 24..... | 5A | 2.40, | 10A | 2.65.. | 5 05... | <i>Amazed</i> |
| 30..... | 4A | 3.10, | 8A | 3.35.. | 6 45... | <i>Amazing</i> |

Antique Ext'd No. 123. E *Amazingly*

| | | | | | | |
|-----------|-----|-------|-------|-------|---------|------------------|
| 5 Pt..... | 24A | | | | 1 65... | <i>Amber</i> |
| 6..... | 24A | | | | 1 90... | <i>Ambergris</i> |
| 8..... | 24A | | | | 2 25... | <i>Ambition</i> |
| 10..... | 18A | | | | 2 05... | <i>Ambled</i> |
| 12..... | 16A | | | | 2 35... | <i>Ambtingly</i> |

Antique Ext'd No. 124. E *Ambrosia*

| | | | | | | |
|-----------|-----|-------|-----|--------|----------|------------------|
| 6 Pt..... | 18A | 1.35, | 36A | 1.55.. | 2 90... | <i>Ambulate</i> |
| 8..... | 16A | 1.45, | 32A | 1.85.. | 3 30... | <i>Ambuscade</i> |
| 10..... | 10A | 1.25, | 20A | 1.50.. | 2 75... | <i>Ambush</i> |
| 12..... | 10A | 1.65, | 20A | 2.00.. | 3 65... | <i>Amenable</i> |
| 18..... | 8A | 2.00, | 16A | 2.45.. | 4 45... | <i>Amends</i> |
| 24..... | 6A | 2.50, | 12A | 2.95.. | 5 45... | <i>Amenity</i> |
| 30..... | 4A | 3.15, | 8A | 3.25.. | 6 40... | <i>Amerce</i> |
| 42..... | 3A | 5.25, | 6A | 5.15.. | 10 40... | <i>Amethyst</i> |

Antique Ex. Cond. No. 150. F *Antelope*

| | | | | | | |
|-----------|-----|-------|-----|--------|----------|-------------------|
| 8 Pt..... | 22A | 1.40, | 32A | 1.10.. | 2 50... | <i>Antemetic</i> |
| 10..... | 20A | 1.40, | 32A | 1.35.. | 2 75... | <i>Antenna</i> |
| 12..... | 16A | 1.55, | 26A | 1.45.. | 3 00... | <i>Antepast</i> |
| 18..... | 14A | 1.90, | 20A | 1.35.. | 3 25... | <i>Anterior</i> |
| 20..... | 10A | 2.00, | 16A | 1.50.. | 3 50... | <i>Anteroom</i> |
| 24..... | 11A | 1.75, | 17A | 2.00.. | 3 75... | <i>Anthology</i> |
| 30..... | 9A | 2.25, | 12A | 1.75.. | 4 00... | <i>Anthracite</i> |
| 36..... | 7A | 2.40, | 11A | 1.85.. | 4 25... | <i>Anticor</i> |
| 42..... | 5A | 2.60, | 8A | 1.90.. | 4 50... | <i>Antics</i> |
| 48..... | 4A | 3.25, | 7A | 1.75.. | 5 00... | <i>Antidotat</i> |
| 60..... | 4A | 3.60, | 6A | 2.90.. | 6 50... | <i>Antipathy</i> |
| 72..... | 3A | 4.80, | 5A | 3.70.. | 8 50... | <i>Antiphon</i> |
| *96..... | 3A | 6.65, | 4A | 4.20.. | 10 85... | <i>Antipodes</i> |

Antique Fractions. A

| | | | |
|--------------------|-----------|---------|------------------|
| 12 Pt. No. 22..... | per font, | 1 00... | <i>Antre</i> |
| 14..... | 22 | 1 00... | <i>Anvil</i> |
| 18..... | 20 | 1 00... | <i>Anxiety</i> |
| 18..... | 22 | 1 00... | <i>Anxious</i> |
| 30..... | 20 | 1 00... | <i>Anxiously</i> |
| 36..... | 20 | 1 00... | <i>Apace</i> |

Antique Pointed No. 120. E *Apoplexy*

| | | | | | | |
|------------|-----|-------|-----|--------|---------|------------------|
| 12 Pt..... | 10A | 1.20, | 20A | 1.35.. | 2 55... | <i>Aporia</i> |
| 18..... | 8A | 1.85, | 16A | 2.00.. | 3 85... | <i>Apostacy</i> |
| 24..... | 6A | 1.85, | 12A | 2.05.. | 3 90... | <i>Apostate</i> |
| 30..... | 5A | 2.15, | 10A | 2.35.. | 4 50... | <i>Aposteme</i> |
| 36..... | 4A | 3.25, | 8A | 3.45.. | 6 70... | <i>Apostles</i> |
| 42..... | 3A | 3.60, | 6A | 3.85.. | 7 45... | <i>Apostotic</i> |
| 48..... | 3A | 5.30, | 5A | 4.35.. | 9 65... | <i>Apothegm</i> |

Apollo. F *Aptitude*

| | | | | | | |
|-----------|-----|-------|-----|--------|---------|----------------|
| 8 Pt..... | 20A | 1.50, | 44A | 1.50.. | 3 00... | <i>Aptly</i> |
| 10..... | 14A | 1.50, | 32A | 1.75.. | 3 25... | <i>Aptness</i> |
| 12..... | 12A | 1.60, | 28A | 1.90.. | 3 50... | <i>Aptote</i> |
| 18..... | 9A | 1.90, | 18A | 2.10.. | 4 00... | <i>Aquatic</i> |

APPLE BLOSSOM ORNAMENTS (see Ornaments).

Aquatint. C *Arabist*

| | | | | | | |
|------------|-----|-------|-----|--------|---------|------------------|
| 12 Pt..... | 14A | 1.95, | 20A | 1.75.. | 3 70... | <i>Arabe</i> |
| 18..... | 10A | 2.30, | 14A | 1.95.. | 4 25... | <i>Arbatist</i> |
| 24..... | 7A | 3.00, | 10A | 2.55.. | 5 55... | <i>Arbiter</i> |
| 36..... | 5A | 4.20, | 7A | 3.00.. | 7 20... | <i>Arbitrary</i> |

Archaic. c

| | | | | | |
|-----------|-----|---------|-----|---------|-----------|
| 6 Pt..... | 36A | \$1.25, | 70a | \$1.45. | \$2 70... |
| 9..... | 30A | 1.45, | 50a | 1.45. | 2 90... |
| 12..... | 25A | 1.55, | 40a | 1.55. | 3 10... |
| 18..... | 14A | 1.85, | 26a | 1.90. | 3 75... |
| 24..... | 10A | 2.10, | 18a | 2.15. | 4 25... |
| 30..... | 8A | 2.40, | 14a | 2.60. | 5 00... |
| 36..... | 7A | 3.20, | 10a | 2.80. | 6 00... |

Archives

| |
|---------------------------|
| 2 70... <i>Archly</i> |
| 2 90... <i>Archness</i> |
| 3 10... <i>Archon</i> |
| 3 75... <i>Archway</i> |
| 4 25... <i>Arcuate</i> |
| 5 00... <i>Arcubalist</i> |
| 6 00... <i>Ardency</i> |

Arithmetical Signs No. 150 F

| | | |
|------------|-----------|--------------------------|
| 5½ Pt..... | per font, | 2 40... <i>Armory</i> |
| 6..... | | 2 00... <i>Armpit</i> |
| 7..... | | 1 80... <i>Army</i> |
| 8..... | | 1 60... <i>Aroma</i> |
| 9..... | | 1 44... <i>Aromatic</i> |
| 10..... | | 1 30... <i>Arose</i> |
| 11..... | | 1 22... <i>Aroynt</i> |
| 12..... | | 1 16... <i>Arquibuse</i> |

Arlington. F

| | | | | | |
|------------|-------------------|-------|-----|-------|--------------------------|
| 10 Pt..... | 20A | 1.50, | 26a | 1.25. | 2 75... <i>Arrogated</i> |
| 12..... | 16A | 1.70, | 20a | 1.30. | 3 00... <i>Arrow</i> |
| 18..... | 10A | 1.70, | 16a | 1.55. | 3 25... <i>Arrowroot</i> |
| 24..... | 8A | 2.30, | 10a | 1.70. | 4 00... <i>Arsenals</i> |
| 30..... | 6A | 2.70, | 9a | 2.30. | 5 00... <i>Arsenic</i> |
| 36..... | 5A | 3.00, | 8a | 2.50. | 5 50... <i>Arsenical</i> |
| 48..... | 4A | 4.65, | 5a | 3.10. | 7 75... <i>Arson</i> |
| 60..... |) In preparation. | | | | |
| 72..... |) In preparation. | | | | |

Arrogance

Armenian. B

| | |
|--|---------|
| 10 Pt...Smallest font, 25 lbs...per lb.. | 1 30... |
| 14..... " " 25 lbs..... | 1 12... |

Army and Navy. E

| | | |
|------------|-----------|--------------------------|
| No. 1..... | per font, | 2 00... <i>Artfully</i> |
| No. 2..... | | 2 00... <i>Artichoke</i> |

Artful

Arrows. B

| | | |
|-----------|---------------|------------------------|
| 6 Pt..... | per set of 3, | 15... <i>Articular</i> |
|-----------|---------------|------------------------|

Art Borders. F

| | | |
|-------------------------|---------------|-------------------------------|
| 6 Pt. No. 3 (Tint)..... | .60 inches, | 1 50... <i>Articulate</i> |
| 6..... | 4 (Tint)..... | 1 50... <i>Articulary</i> |
| 6..... | 6 (Open)..... | 1 50... |
| 6..... | 8 (Tint)..... | 1 50... <i>Articulary</i> |
| 12..... | 1..... | 1 60... <i>Articulata</i> |
| 12..... | 2..... | 1 60... <i>Articulate</i> |
| 12..... | 3 (Tint)..... | 1 60... <i>Articulated</i> |
| 12..... | 3 (Open)..... | 1 60... |
| 12..... | 4 (Tint)..... | 1 60... <i>Articulately</i> |
| 12..... | 4 (Open)..... | 1 60... |
| 12..... | 5 (Tint)..... | 1 60... <i>Articulating</i> |
| 12..... | 5 (Open)..... | 1 60... |
| 12..... | 6 (Open)..... | 1 60... |
| 12..... | 7 (Tint)..... | 1 60... <i>Articulation</i> |
| 12..... | 7 (Open)..... | 1 60... |
| 12..... | 8 (Tint)..... | 1 60... <i>Articulative</i> |
| 12..... | 8 (Open)..... | 1 60... |
| 12..... | 9..... | 1 60... <i>Articulator</i> |
| 12..... | 10..... | 1 60... <i>Articulators</i> |
| 12..... | 11..... | 1 60... <i>Articulatory</i> |
| 12..... | 12..... | 1 60... <i>Articulus</i> |
| 12..... | 21..... | 1 60... <i>Artier</i> |
| 18..... | 3 (Tint)..... | 2 00... <i>Artifact</i> |
| 18..... | 3 (Open)..... | 2 00... |
| 18..... | 4 (Tint)..... | 2 00... <i>Artifactor</i> |
| 18..... | 4 (Open)..... | 2 00... |
| 18..... | 5 (Tint)..... | 2 00... <i>Artifex</i> |
| 18..... | 5 (Open)..... | 2 00... |
| 18..... | 6 (Open)..... | 2 00... |
| 18..... | 7 (Tint)..... | 2 00... <i>Artifexed</i> |
| 18..... | 7 (Open)..... | 2 00... |
| 18..... | 9..... | 2 00... <i>Artifexing</i> |
| 18..... | 10..... | 2 00... <i>Artifice</i> |
| 18..... | 11..... | 2 00... <i>Artificer</i> |
| 18..... | 17..... | 2 00... <i>Artificial</i> |
| 18..... | 18..... | 2 00... <i>Artificiality</i> |
| 18..... | 22..... | 2 00... <i>Artificialize</i> |
| 18..... | 24..... | 2 00... <i>Artificially</i> |
| 18..... | 25..... | 2 00... <i>Artificialness</i> |
| 24..... | 3 (Open)..... | 1 65... |
| 24..... | 3 (Tint)..... | 1 65... <i>Artifitious</i> |
| 24..... | 6..... | 1 65... <i>Artilize</i> |
| 24..... | 7 (Open)..... | 1 65... |
| 24..... | 7 (Tint)..... | 1 65... <i>Artilizing</i> |
| 24..... | 9..... | 1 65... <i>Artiller</i> |
| 24..... | 10..... | 1 65... <i>Artillerist</i> |

Art Borders—Continued.

| | | | |
|-------------------|------------|----------------------------|-----------------------------|
| 24Pt. No. 11..... | 33 inches, | \$1 65... <i>Artillery</i> | |
| 24..... | 15..... | 36..... | 1 65... <i>Artilleryman</i> |
| 24..... | 18..... | 36..... | 1 65... <i>Artisan</i> |
| 24..... | 19..... | 36..... | 1 65... <i>Artist</i> |
| 24..... | 20..... | 36..... | 1 65... <i>Artiste</i> |
| 24..... | 23..... | 36..... | 1 65... <i>Artistic</i> |
| 24..... | 24..... | 36..... | 1 65... <i>Artistical</i> |
| 24..... | 25..... | 36..... | 1 65... <i>Artistry</i> |
| 30..... | 1..... | 36..... | 1 65... <i>Artize</i> |
| 36..... | 25..... | 12..... | 1 10... <i>Artized</i> |

Art Gothic. F

| | | | | | |
|------------|-----|---------|-----|---------|--------------------------|
| 10 Pt..... | 18A | \$1.50, | 28a | \$1.25. | 2 75... <i>Artlessly</i> |
| 12..... | 14A | 1.60, | 20a | 1.40. | 3 00... <i>Aruspice</i> |
| 18..... | 12A | 1.70, | 16a | 1.30. | 3 00... <i>Asbestine</i> |
| 24..... | 8A | 2.25, | 10a | 1.75. | 4 00... <i>Ascend</i> |
| 36..... | 6A | 3.00, | 8a | 2.00. | 5 00... <i>Ascendant</i> |
| 48..... | 4A | 3.80, | 5a | 2.70. | 6 50... <i>Ascension</i> |
| 60..... | 4A | 5.40, | 5a | 3.80. | 9 20... <i>Ascetic</i> |
| 72..... | 3A | 5.75, | 5a | 4.25. | 10 00... <i>Ascribe</i> |

Artless

ART INITIALS (see Initials).

Astronomical Signs. F

| | | | |
|--------------------|-----------|---------------------------|------------------------|
| 6 Pt. No. 151..... | per font, | 2 25... <i>Assume</i> | |
| 7..... | 151..... | 2 75... <i>Assuming</i> | |
| 8..... | 151..... | 5 00... <i>Assurance</i> | |
| 8..... | 152..... | 2 00... <i>Assure</i> | |
| 9..... | 151..... | 5 00... <i>Assuredly</i> | |
| 9..... | 152..... | 2 25... <i>Assuring</i> | |
| 10..... | 151..... | 4 75... <i>Asterisk</i> | |
| 10..... | 152..... | 3 00... <i>Astern</i> | |
| 11..... | 151..... | 4 50... <i>Asteroid</i> | |
| 11..... | 152..... | 3 00... <i>Asteroidal</i> | |
| 12..... | 151..... | 4 50... <i>Astert</i> | |
| 12..... | 152..... | 3 00... <i>Asthenic</i> | |
| 12..... | 153..... | 3 00... <i>Astheny</i> | |
| 14..... | 151..... | 5 40... <i>Asthma</i> | |
| 16..... | 150..... | set of four, | 25... <i>Athanor</i> |
| 20..... | 150..... | set of four, | 30... <i>Atheism</i> |
| 24..... | 150..... | set of four, | 30... <i>Atheistic</i> |

Athletes. E

| | |
|---------------|-------------------------|
| Per font..... | 1 50... <i>Athletes</i> |
|---------------|-------------------------|

Atlanta. F

| | | |
|-----------|----------|--------------------------|
| 6 Pt..... | 28A..... | 2 25... <i>Atom</i> |
| 8..... | 20A..... | 2 50... <i>Atomic</i> |
| 10..... | 16A..... | 2 75... <i>Atoned</i> |
| 12..... | 12A..... | 3 00... <i>Atonement</i> |
| 14..... | 9A..... | 3 25... <i>Atrocitly</i> |
| 18..... | 8A..... | 3 50... <i>Attack</i> |
| 24..... | 6A..... | 4 50... <i>Attacked</i> |
| 30..... | 5A..... | 5 00... <i>Attain</i> |
| 36..... | 4A..... | 6 75... <i>Attainder</i> |
| 42..... | 4A..... | 7 25... <i>Attempt</i> |
| 48..... | 4A..... | 10 00... <i>Attend</i> |

Augustan Text. A

| | | | | | |
|-----------|-----|-------|-----|-------|---------------------------|
| 6 Pt..... | 20A | 1.33, | 70a | 1.60. | 2 93... <i>Available</i> |
| 8..... | 20A | 1.66, | 40a | 1.40. | 3 06... <i>Avaling</i> |
| 10..... | 10A | 1.65, | 40a | 1.37. | 3 02... <i>Avantanche</i> |
| 12..... | 8A | 1.74, | 24a | 1.60. | 3 34... <i>Avarice</i> |
| 18..... | 8A | 2.49, | 16a | 2.00. | 4 49... <i>Avatar</i> |
| 24..... | 6A | 2.50, | 14a | 2.67. | 5 17... <i>Avaunt</i> |

Autograph Script. A

| | | | | | |
|-----------|----|-------|-----|-------|--------------------------|
| 24Pt..... | 7A | 4.00, | 16a | 4.00. | 8 00... <i>Axiomatic</i> |
|-----------|----|-------|-----|-------|--------------------------|

Ballet Dancers. F

| | |
|---------------|------------------------|
| Per font..... | 2 00... <i>Babbler</i> |
|---------------|------------------------|

Barta Borders. A

| | | | |
|--------------------|-------------|------------------------|----------------------------|
| 8 Pt. No. 290..... | .50 inches, | 1 50... <i>Bariola</i> | |
| 12..... | 244..... | 36..... | 1 50... <i>Bariolage</i> |
| 12..... | 282..... | 36..... | 1 50... <i>Bariolera</i> |
| 12..... | 285..... | 36..... | 1 50... <i>Bariolous</i> |
| 12..... | 286..... | 36..... | 1 50... <i>Baritah</i> |
| 12..... | 292..... | 36..... | 1 50... <i>Barite</i> |
| 14..... | 245..... | 36..... | 1 50... <i>Baritel</i> |
| 18..... | 241..... | 30..... | 1 50... <i>Baritone</i> |
| 18..... | 246..... | 30..... | 1 50... <i>Barium</i> |
| 18..... | 247..... | 30..... | 1 50... <i>Bark</i> |
| 18..... | 248..... | 30..... | 1 50... <i>Barkkeeper</i> |
| 18..... | 249..... | 30..... | 1 50... <i>Barkkeeping</i> |
| 18..... | 250..... | 30..... | 1 50... <i>Barken</i> |
| 18..... | 291..... | 30..... | 1 50... <i>Barkentine</i> |
| 24..... | 242..... | 20..... | 1 50... <i>Barker</i> |

Barta Borders—Continued.

| | | | |
|---------------------|------------|---------|-------------------|
| 24 Pt. No. 281..... | 20 inches, | \$1 50 | ...Barkery |
| 24..... | 284..... | 20..... | 1 50...Barkgalled |
| 24..... | 289..... | 20..... | 1 50...Barking |
| 30..... | 243..... | 20..... | 1 50...Barkless |
| 30..... | 251..... | 20..... | 1 50...Barklouse |
| 36..... | 252..... | 18..... | 1 50...Barkmill |
| 36..... | 253..... | 18..... | 1 50...Barkometer |
| 36..... | 254..... | 18..... | 1 50...Barkpaper |
| 36..... | 255..... | 18..... | 1 50...Barkpit |
| 36..... | 287..... | 18..... | 1 50...Barkstone |
| 36..... | 288..... | 18..... | 1 50...Barkstove |
| 48..... | 283..... | 12..... | 1 50...Barktanned |
| 54..... | 293..... | 24..... | 3 00...Barky |
| 72..... | 294..... | 24..... | 3 00...Barley |

Barth Geometrical Border.

Per font..... 3 00...Barleybigg

Baseball Series 1.

Per font..... 1 50...Barleybird

Bearerers.

Fonts of 25 lbs. and over of any one size at Roman prices.

| | | |
|-----------|----------|---------|
| 6 Pt..... | per lb., | 1 16... |
| 7..... | | 1 00... |
| 8..... | | 90... |
| 9..... | | 80... |
| 10..... | | 74... |
| 11..... | | 70... |
| 12..... | | 66... |

Bijou.

| | | |
|------------|--------------------------|-----------------|
| 12 Pt..... | 12A \$1.80, 32a \$2.75.. | 4 55...Basanite |
| 18..... | 8A 2.20, 20a 3.15.. | 5 35...Bascinet |
| 24..... | 6A 2.35, 14a 3.40.. | 5 75...Bascule |

Billhead Logotypes.

Per font..... 5 00...Baseminded

Binner.

| | | |
|-----------|----------------------|------------------|
| 6 Pt..... | 24A 1.40, 36a 1.10.. | 2 50...Basement |
| 8..... | 22A 1.55, 30a 1.20.. | 2 75...Baserez |
| 10..... | 20A 1.70, 26a 1.30.. | 3 00...Basering |
| 12..... | 16A 1.95, 20a 1.30.. | 3 25...Bases |
| 18..... | 10A 2.10, 16a 1.90.. | 4 00...Basfond |
| 24..... | 8A 2.70, 10a 1.80.. | 4 50...Bashaw |
| 30..... | 6A 2.90, 9a 2.10.. | 5 00...Bashful |
| 36..... | 5A 3.00, 8a 2.50.. | 5 50...Bashfully |
| 48..... | 4A 4.90, 5a 2.85.. | 7 75...Bashless |
| 54..... | 4A 6.50, 5a 3.75.. | 10 25...Bashlyk |
| 60..... | 4A 7.50, 5a 4.75.. | 12 25...Basial |
| 72..... | 4A 10.35, 5a 6.65.. | 17 00...Basiator |

Binner Gothic.

| | | |
|------------|----------------------|--------------------|
| 18 Pt..... | 18A 1.75, 27a 1.50.. | 3 25...Basicity |
| 24..... | 14A 2.20, 20a 1.80.. | 4 00...Basieranial |
| 30..... | 12A 2.60, 18a 2.40.. | 5 00...Basidia |
| 36..... | 10A 3.15, 15a 2.85.. | 6 00...Basidigital |
| 48..... | 8A 3.70, 12a 3.30.. | 7 00...Basidium |
| 60..... | 7A 4.30, 10a 3.70.. | 8 00...Basijfer |
| 72..... | 5A 4.80, 8a 4.20.. | 9 00...Basijzed |

Binner Open.

| | | |
|------------|----------------------|-------------------|
| 12 Pt..... | 16A 1.95, 20a 1.30.. | 3 25...Basigynium |
| 18..... | 10A 2.10, 16a 1.90.. | 4 00...Basihyoid |
| 24..... | 8A 2.70, 10a 1.80.. | 4 50...Basil |
| 36..... | 5A 3.00, 8a 2.50.. | 5 50...Basilad |
| 48..... | 4A 4.90, 5a 2.85.. | 7 75...Basilaire |
| 60..... | 4A 7.50, 5a 4.75.. | 12 25...Basiliary |
| 72..... | 4A 10.35, 5a 6.65.. | 17 00...Basilica |

BINNY OLD STYLE NO. 77 (sold at Roman prices).

Black No. 11.

10 Pt..... 12A 1.79, 32a 1.80.. 3 59...Bastardy

Black No. 12.

| | | |
|------------|----------------------|------------------|
| 12 Pt..... | 10A 2.00, 28a 1.90.. | 3 90...Battiez |
| 24..... | 4A 2.20, 10a 2.44.. | 4 64...Battimes |
| 30..... | 4A 2.69, 6a 2.00.. | 4 69...Battions |
| 36..... | 3A 3.17, 6a 3.17.. | 6 34...Battirent |

Black No. 13.

| | | |
|-----------|----------------------|-------------------|
| 6 Pt..... | 20A 1.88, 62a 1.75.. | 3 63...Battleaxe |
| 8..... | 20A 2.00, 50a 1.78.. | 3 78...Battledore |
| 10..... | 16A 1.94, 40a 1.80.. | 3 74...Battlement |
| 12..... | 10A 2.00, 40a 2.49.. | 4 49...Battles |

Black No. 22.

| | | |
|------------|-------------------------|--------------------|
| 12 Pt..... | 9A \$1.25, 30a \$1.25.. | \$2 50...Battology |
| 18..... | 6A 1.35, 20a 1.40.. | 2 75...Batrais |
| 24..... | 6A 1.60, 14a 1.40.. | 3 00...Battrout |

Boldface Borussian.

| | | |
|-----------|----------------------|------------------|
| 8 Pt..... | 14A 1.60, 42a 1.70.. | 3 30...Beggardy |
| 11..... | 12A 1.45, 32a 1.65.. | 3 10...Begdiled |
| 14..... | 8A 1.75, 20a 1.95.. | 3 70...Begdiling |
| 24..... | 6A 2.00, 14a 2.05.. | 4 05...Beginners |
| 36..... | 4A 2.85, 7a 2.65.. | 5 50...Beginneth |

Boldface Celtic.

| | | |
|-----------|----------------------|-----------------|
| 6 Pt..... | 30A 1.50, 50a 1.40.. | 2 90...Behappen |
| 8..... | 30A 1.95, 50a 1.40.. | 3 35...Behaving |
| 10..... | 25A 2.10, 40a 1.85.. | 3 95...Behavior |
| 12..... | 15A 1.85, 25a 1.45.. | 3 30...Behaded |
| 18..... | 10A 1.85, 15a 1.50.. | 3 35...Behading |
| 24..... | 8A 2.40, 12a 2.00.. | 4 40...Beheld |
| 30..... | 6A 3.15, 10a 2.25.. | 5 40...Behemoth |
| 36..... | 4A 3.25, 6a 2.30.. | 5 55...Behest |
| 42..... | 4A 4.25, 6a 3.25.. | 7 50...Behind |

Boldface German.

| | | |
|-----------|----------------------|-------------------|
| 6 Pt..... | 15A 1.15, 50a 1.45.. | 2 60...Belcerons |
| 8..... | 15A 1.30, 50a 1.65.. | 2 95...Belgry |
| 9..... | 15A 1.40, 50a 1.95.. | 3 35...Belgard |
| 10..... | 12A 1.30, 40a 1.70.. | 3 00...Belgravian |
| 12..... | 9A 1.35, 30a 1.65.. | 3 00...Belial |

Boldface Italic No. 15.

| | | |
|-----------|----------------------|-----------------|
| 5 Pt..... | 24A 1.40, 44a 1.30.. | 2 70...Belike |
| 24..... | 8A 2.10, 20a 2.30.. | 4 40...Belime |
| 30..... | 6A 2.52, 10a 2.24.. | 4 76...Belinked |
| 36..... | 6A 4.74, 10a 3.78.. | 8 52...Belittle |

Boldface Italic No. 22.

36 Pt..... 5A 3.25, 7a 2.25.. 5 50...Belittlement

Boldface Italic No. 23.

*48 Pt..... 4A 4.25, 6a 2.75.. 7 00...Belive

Boldface Italic No. 27.

5½ Pt..... 24A 1.20, 38a 1.05.. 2 25...Bell

Boldface Italic No. 120.

| | | |
|-----------|----------------------|------------------|
| 6 Pt..... | 24A 1.05, 48a 1.20.. | 2 25...Bereft |
| 7..... | 24A 1.15, 48a 1.40.. | 2 55...Beregamot |
| 8..... | 24A 1.40, 48a 1.60.. | 3 00...Beryl |
| 9..... | 24A 1.35, 48a 1.60.. | 2 95...Besech |
| 10..... | 18A 1.40, 36a 1.50.. | 2 90...Besetting |
| 11..... | 18A 1.50, 36a 1.55.. | 3 05...Besiege |
| 12..... | 12A 1.25, 24a 1.40.. | 2 65...Besmear |
| 18..... | 12A 1.85, 24a 2.05.. | 3 90...Besmirch |
| 24..... | 10A 2.15, 20a 2.40.. | 4 55...Besom |
| 30..... | 6A 2.20, 12a 2.35.. | 4 55...Besotted |

Boldface No. 114.

| | | |
|-------------|--------------------|------------------|
| *36 Pt..... | 4A 2.60, 8a 2.60.. | 5 20...Bespangle |
| *48..... | 4A 3.15, 4a 3.15.. | 6 30...Bespatter |

Boldface No. 120.

| | | |
|------------|----------------------|------------------|
| 5½ Pt..... | 24A 1.25, 48a 1.40.. | 2 65...Bestial |
| 6..... | 24A 1.05, 48a 1.25.. | 2 30...Bestir |
| 7..... | 24A 1.20, 48a 1.40.. | 2 60...Bestowal |
| 8..... | 24A 1.50, 48a 1.60.. | 3 10...Bestride |
| 9..... | 24A 1.40, 48a 1.60.. | 3 00...Bestudded |
| 10..... | 18A 1.35, 36a 1.45.. | 2 80...Betake |
| 11..... | 18A 1.35, 36a 1.55.. | 2 90...Betaking |
| 12..... | 12A 1.20, 24a 1.40.. | 2 60...Bethink |
| 18..... | 12A 2.10, 24a 2.45.. | 4 55...Betide |
| 24..... | 10A 2.25, 20a 2.60.. | 4 85...Betimes |
| 30..... | 6A 2.45, 12a 2.80.. | 5 25...Betokens |

Boldface No. 120 Fractions.

| | | |
|------------|-------------|----------------|
| 12 Pt..... | 1-lb. font, | 66...Betray |
| 18..... | | 60...Betrayers |
| 24..... | | 60...Betrowth |
| 30..... | | 56...Betwixt |

Boston Black.

| | | |
|------------|---------------------|------------------|
| 12 Pt..... | 5A 1.25, 18a 1.50.. | 2 75...Bimanous |
| 18..... | 5A 1.40, 14a 1.60.. | 3 00...Bimensal |
| 24..... | 4A 1.95, 10a 1.55.. | 3 50...Binary |
| 30..... | 4A 2.20, 6a 1.80.. | 4 00...Binding |
| 36..... | 3A 2.55, 4a 1.95.. | 4 50...Binocular |

Boston Script. A *Birgander*

| | | |
|------------|-------------------------|---------------------------|
| 18 Pt..... | 9A \$3.00, 25a \$3.00.. | \$6 00... <i>Birth</i> |
| | 3A 10a | 2 00... <i>Birthday</i> |
| 24..... | 7A 4.00, 20a 4.00.. | 8 00... <i>Birthdom</i> |
| | 5A 8a | 3 00... <i>Birthright</i> |
| 36..... | 5A 5.00, 15a 5.00.. | 10 00... <i>Biscuit</i> |
| 48..... | 4A 6.00, 10a 6.00.. | 12 00... <i>Bisect</i> |
| 60..... | 3A 7.50, 8a 7.50.. | 15 00... <i>Bisection</i> |

EXTRA CAPS.

| | |
|------------|------------------------|
| 18 Pt..... | 50... <i>Biseympt</i> |
| 24..... | 75... <i>Bishop</i> |
| 36..... | 75... <i>Bishopric</i> |
| 48..... | 1 00... <i>Bismuth</i> |

Bowlers. A

| | |
|---------------|-----------------------|
| Per font..... | 1 75... <i>Bitter</i> |
|---------------|-----------------------|

Braces. E-F

| | |
|-------------------------------------|---------------------------|
| 6 Pt.. Braces and Dashes No. 2..... | 1 25... <i>Bitumen</i> |
| 6..... Metal Braces..... | 1 00... <i>Bivalve</i> |
| 6..... New Metal Braces..... | 1 00... <i>Bivalvular</i> |

Bradley. C

| | | |
|-----------|----------------------|---------------------------|
| 6 Pt..... | 20A 1.00, 60a 1.25.. | 2 25... <i>Blabbing</i> |
| 8..... | 18A 1.05, 52a 1.45.. | 2 50... <i>Blackberry</i> |
| 10..... | 16A 1.10, 50a 1.65.. | 2 75... <i>Blackbird</i> |
| 12..... | 15A 1.25, 45a 1.75.. | 3 00... <i>Blacken</i> |
| 18..... | 8A 1.35, 25a 1.90.. | 3 25... <i>Blackguard</i> |
| 24..... | 5A 1.40, 16a 2.10.. | 3 50... <i>Blazonry</i> |
| 36..... | 4A 2.30, 10a 2.70.. | 5 00... <i>Bleach</i> |
| 48..... | 3A 3.25, 8a 3.50.. | 6 75... <i>Bleachery</i> |
| 60..... | 3A 4.95, 5a 3.55.. | 8 50... <i>Bleaching</i> |

Bradley Extended. C

| | | |
|-----------|----------------------|----------------------------|
| 6 Pt..... | 20A 1.20, 60a 1.80.. | 3 00... <i>Bleakish</i> |
| 8..... | 16A 1.25, 50a 2.00.. | 3 25... <i>Bleakly</i> |
| 10..... | 16A 1.35, 48a 2.15.. | 3 50... <i>Bleakness</i> |
| 12..... | 14A 1.60, 42a 2.40.. | 4 00... <i>Bleakly</i> |
| 15..... | 12A 1.85, 36a 2.65.. | 4 50... <i>Bleacr</i> |
| 18..... | 10A 2.05, 28a 2.95.. | 5 00... <i>Blearedness</i> |
| 24..... | 6A 2.45, 16a 3.05.. | 5 50... <i>Bleareye</i> |
| 30..... | 5A 2.70, 12a 3.30.. | 6 00... <i>Bleareyed</i> |
| 36..... | 4A 2.80, 10a 3.70.. | 6 50... <i>Bleariness</i> |
| 48..... | 3A 4.35, 6a 4.15.. | 8 50... <i>Blearness</i> |
| 60..... | 3A 6.25, 4a 4.25.. | 10 50... <i>Bleary</i> |

Bradley Initials. C

| | | |
|------------|--------------------|------------------------|
| 42 Pt..... | 3A..... | 3 00... <i>Bleat</i> |
| | Single letter..... | 20... |
| 54..... | 3A..... | 4 25... <i>Bleater</i> |
| | Single letter..... | 25... |

Bradley Italic. C

| | | |
|-----------|----------------------|-------------------------|
| 8 Pt..... | 16A 1.25, 48a 1.50.. | 2 75... <i>Bleaut</i> |
| 10..... | 14A 1.25, 45a 1.75.. | 3 00... <i>Bleb</i> |
| 12..... | 14A 1.45, 40a 1.80.. | 3 25... <i>Bleeb</i> |
| 15..... | 12A 1.50, 36a 2.00.. | 3 50... <i>Bleebok</i> |
| 18..... | 9A 1.75, 26a 2.25.. | 4 00... <i>Bleeked</i> |
| 24..... | 6A 2.05, 18a 2.45.. | 4 50... <i>Bled</i> |
| 30..... | 5A 2.50, 12a 2.50.. | 5 00... <i>Blee</i> |
| 36..... | 4A 2.70, 10a 2.80.. | 5 50... <i>Bleed</i> |
| 48..... | 3A 3.80, 7a 3.45.. | 7 25... <i>Bleeder</i> |
| 60..... | 3A 5.60, 5a 3.40.. | 9 00... <i>Bleeding</i> |

Bradley Italic Outline. C

| | | |
|------------|---------------------|----------------------------|
| 18 Pt..... | 9A 1.75, 26a 2.25.. | 4 00... <i>Bleeze</i> |
| 24..... | 6A 2.05, 18a 2.45.. | 4 50... <i>Blemish</i> |
| 30..... | 5A 2.50, 12a 2.50.. | 5 00... <i>Blemished</i> |
| 36..... | 4A 2.70, 10a 2.80.. | 5 50... <i>Blemishless</i> |
| 48..... | 3A 3.80, 7a 3.45.. | 7 25... <i>Blemishment</i> |
| 60..... | 3A 5.60, 5a 3.40.. | 9 00... <i>Blench</i> |

Bradley Outline. C

| | | |
|------------|---------------------|--------------------------|
| 18 Pt..... | 8A 1.35, 25a 1.90.. | 3 25... <i>Blend</i> |
| 24..... | 5A 1.40, 16a 2.10.. | 3 50... <i>Blendcorn</i> |
| 36..... | 4A 2.30, 10a 2.70.. | 5 00... <i>Blender</i> |
| 48..... | 3A 3.25, 8a 3.50.. | 6 75... <i>Blending</i> |
| 60..... | 3A 4.95, 5a 3.55.. | 8 50... <i>Blendous</i> |

Brass Braces. C

| | |
|--------------------|---------------------------|
| Complete set | 5 60... <i>Blendwater</i> |
|--------------------|---------------------------|

Brass Column Rules.

| | | | | | |
|------------|-------|-------|-------|-------|--------|
| Length. | 6 Pt. | 7 Pt. | 8 Pt. | 9 Pt. | 10 Pt. |
| 13 3/4 in. | .40 | .45 | .50 | .55 | .60 |
| 17 3/4 | .50 | .55 | .65 | .70 | .80 |
| 19 3/4 | .55 | .60 | .70 | .80 | .85 |
| 21 3/4 | .60 | .70 | .75 | .85 | .95 |
| 23 3/4 | .65 | .75 | .85 | .95 | 1.05 |
| 25 3/4 | .70 | .80 | .90 | 1.00 | 1.10 |

Nicked under for Brass Reglet, 10 cts. extra.
Nicked under and over, each 25 cts. extra.

Brass Dash Rules.

Prices are for columns 15 Pica ems wide and under.

| | | |
|-------------------------|-------|-----------|
| Nos. 203A to 203D..... | each, | \$0 06... |
| 219 and 219D..... | each, | 06... |
| 237 and 237D..... | each, | 08... |
| 273 and 273D..... | each, | 08... |
| 293 and 293D..... | each, | 08... |
| 294 and 294D..... | each, | 08... |
| 364 and 364D..... | each, | 06... |
| No. 367..... | | 08... |

Brass Head Rules.

Prices are for any Single, Double, Parallel or Triple Rule.

| | | | | | | |
|----------------|----------|----------|----------|----------|----------|--------|
| | 4 Col. | 5 Col. | 6 Col. | 7 Col. | 8 Col. | 9 Col. |
| 3 Pt. \$0.15.. | \$0.20.. | \$0.25.. | \$0.30.. | \$0.30.. | \$0.35.. | |
| 4..... | .15... | .20... | .25... | .30... | .30... | .35... |
| 5..... | .20... | .25... | .30... | .35... | .40... | .45... |
| 5 1/2..... | .25... | .30... | .35... | .40... | .45... | .50... |
| 6..... | .25... | .30... | .35... | .40... | .45... | .55... |
| 7..... | .30... | .35... | .45... | .50... | .55... | .60... |
| 8..... | .30... | .40... | .50... | .55... | .60... | .70... |

BRASS LEADERS (see Labor-Saving Brass Leaders).

Brass Leads and Slugs.

FULL LENGTH.

| | | |
|-------------------------|----------|---------|
| 1 Pt..... | per lb., | 1 00... |
| 1 1/2 Pt..... | | 80... |
| 2 Pt..... | | 75... |
| 6 Pt. and thicker | | 75... |

CUT COLUMN MEASURE:

| | | |
|-------------------------|----------|---------|
| 1 Pt..... | per lb., | 1 00... |
| 1 1/2 Pt..... | | 80... |
| 2 Pt..... | | 75... |
| 6 Pt. and thicker | | 75... |

CUT LABOR-SAVING:

| | | |
|-------------------------|----------|---------|
| 1 Pt..... | per lb., | 1 50... |
| 1 1/2 Pt..... | | 1 25... |
| 2 Pt..... | | 1 25... |
| 6 Pt. and thicker | | 1 00... |

BRASS NEWSPAPER HEADINGS (see Newspaper Headings).

BRASS PERFORATING RULE (see Perforating Rule).

BRASS RULE (see Labor-Saving Brass Rule).

Brass Scoring Rule.

| | | |
|-----------|-----------|-----------------------|
| 2 Pt..... | per foot, | 10... <i>Blenheim</i> |
| 3..... | | 15... <i>Blennius</i> |
| 4..... | | 20... <i>Blennoil</i> |
| 6..... | | 30... <i>Blenny</i> |

Brass Space Rule.

| | | |
|------------|----------|----------------------------|
| 1 Pt..... | per lb., | 3 50... <i>Blens</i> |
| 1 1/2..... | | 2 75... <i>Blepharal</i> |
| 2..... | | 2 00... <i>Blepharitis</i> |

Breton. A

| | | |
|-----------|--------------------------|-------------------------|
| 6 Pt..... | 28A \$1.25, 42a \$1.00.. | 2 25... <i>Bookcase</i> |
| 8..... | 24A 1.35, 36a 1.15.. | 2 50... <i>Bookworm</i> |
| 10..... | 20A 1.50, 30a 1.25.. | 2 75... <i>Boorish</i> |
| 12..... | 16A 1.70, 24a 1.30.. | 3 00... <i>Bootjack</i> |
| 18..... | 12A 1.75, 18a 1.50.. | 3 25... <i>Booty</i> |
| 24..... | 7A 2.25, 10a 1.75.. | 4 00... <i>Bopeep</i> |
| 42..... | 3A 2.90, 4a 2.10.. | 5 00... <i>Borax</i> |
| 48..... | 3A 5.30, 3a 2.70.. | 8 00... <i>Border</i> |

Brier Border. F

| | | |
|---------------|------------|--------------------------|
| Per font..... | 18 inches, | 2 00... <i>Bordering</i> |
|---------------|------------|--------------------------|

Cadet. A

| | | |
|------------|----------------------|---------------------------|
| 10 Pt..... | 16A 1.35, 22a 1.40.. | 2 75... <i>Carboys</i> |
| 12..... | 12A 1.40, 18a 1.60.. | 3 00... <i>Carbuncte</i> |
| 14..... | 8A 1.40, 14a 1.60.. | 3 00... <i>Carburated</i> |
| 16..... | 7A 1.30, 12a 1.70.. | 3 00... <i>Carcajon</i> |
| 18..... | 6A 1.50, 10a 1.75.. | 3 25... <i>Carcanet</i> |
| 24..... | 5A 1.75, 9a 2.00.. | 3 75... <i>Carcaass</i> |
| 36..... | 3A 2.25, 6a 2.25.. | 4 50... <i>Carcelage</i> |

Caledonian Fractions. F

| | | |
|------------|-------------|---------------------|
| 18 Pt..... | 1 lb. font, | 60... <i>Carene</i> |
|------------|-------------|---------------------|

Calendar Figures. F

| | | |
|---------------|---------------------|------------------------|
| No. 1801..... | per font, \$1 00... | <i>Carventare</i> |
| 1802..... | 75... | <i>Carvess</i> |
| 1805..... | 1 00... | <i>Carvesses</i> |
| 1806..... | 1 00... | <i>Carvessing</i> |
| 1807..... | 75... | <i>Carvessingly</i> |
| 1810..... | 1 00... | <i>Carvret</i> |
| 1811..... | 1 00... | <i>Carvretaker</i> |
| 1812..... | 1 00... | <i>Carveth</i> |
| 2008..... | 1 25... | <i>Carveworn</i> |
| 2401..... | 1 25... | <i>Carvex</i> |
| 2402..... | 1 00... | <i>Carvof</i> |
| 2405..... | 1 30... | <i>Carvofax</i> |
| 2406..... | 1 30... | <i>Carvofa</i> |
| 2407..... | 1 00... | <i>Carvofason</i> |
| 2408..... | 1 40... | <i>Carvofeese</i> |
| 2410..... | 1 25... | <i>Carvofa</i> |
| 2411..... | 1 35... | <i>Carvofacas</i> |
| 3001..... | 1 90... | <i>Carvofamoid</i> |
| 3002..... | 1 35... | <i>Carvofam</i> |
| 3005..... | 1 95... | <i>Carvofiate</i> |
| 3006..... | 1 95... | <i>Carvofiated</i> |
| 3007..... | 1 45... | <i>Carvofibbean</i> |
| 3008..... | 1 65... | <i>Carvofibee</i> |
| 3010..... | 1 75... | <i>Carvofibon</i> |
| 3011..... | 2 15... | <i>Carvofica</i> |
| 3001..... | 2 30... | <i>Carvoficature</i> |
| 3602..... | 1 90... | <i>Carvoficaturist</i> |
| 3605..... | 2 50... | <i>Carvofices</i> |
| 3606..... | 2 60... | <i>Carvoficologist</i> |
| 3607..... | 1 90... | <i>Carvoficons</i> |
| 3608..... | 2 15... | <i>Carvofida</i> |
| 3610..... | 2 20... | <i>Carvofidean</i> |
| 3611..... | 2 80... | <i>Carvofides</i> |
| 4201..... | 3 15... | <i>Carvofies</i> |
| 4202..... | 2 40... | <i>Carvofillon</i> |
| 4205..... | 3 30... | <i>Carvofina</i> |
| 4206..... | 3 50... | <i>Carvofinarian</i> |
| 4207..... | 2 25... | <i>Carvofinated</i> |
| 4208..... | 3 10... | <i>Carvofinuating</i> |
| 4210..... | 3 00... | <i>Carvofinella</i> |
| 4801..... | 3 65... | <i>Carvofiniform</i> |
| 4802..... | 3 00... | <i>Carvofions</i> |
| 4805..... | 3 90... | <i>Carvofjack</i> |
| 4806..... | 4 00... | <i>Carvofjacon</i> |
| 4810..... | 3 75... | <i>Carvofk</i> |
| 5401..... | 4 70... | <i>Carvofking</i> |
| 5402..... | 3 80... | <i>Carvofkled</i> |
| 5405..... | 5 00... | <i>Carvofle</i> |
| 5406..... | 5 20... | <i>Carvoflet</i> |
| 5407..... | 3 60... | <i>Carvoflick</i> |
| 5408..... | 4 65... | <i>Carvofline</i> |
| 5410..... | 4 65... | <i>Carvoflomen</i> |
| 5411..... | 4 80... | <i>Carvofminates</i> |
| 6001..... | 5 50... | <i>Carvofminative</i> |
| 6002..... | 4 45... | <i>Carvofmorage</i> |
| 6005..... | 4 50... | <i>Carvofornalism</i> |
| 6006..... | 5 90... | <i>Carvofornalized</i> |
| 6007..... | 4 00... | <i>Carvofornally</i> |
| 6008..... | 5 25... | <i>Carvofornations</i> |
| 6010..... | 5 25... | <i>Carvofornelian</i> |
| 6011..... | 5 75... | <i>Carvofornetwork</i> |

Caligraph. E

12 Pt. No. 4.....15A \$1.55, 70a \$4.65.. 6 20...*Carvofpetbag*

Camelot Old Style. A

| | | |
|-----------|----------------------|---------------------------------|
| 6 Pt..... | 24A 1.10, 50a 1.40.. | 2 50... <i>Carvofseman</i> |
| 8..... | 20A 1.45, 44a 1.55.. | 3 00... <i>Carvofsementated</i> |
| 10..... | 18A 1.55, 40a 1.95.. | 3 50... <i>Carvofsements</i> |
| 12..... | 16A 1.90, 36a 2.10.. | 4 00... <i>Carvofseshot</i> |
| 18..... | 12A 2.30, 18a 1.95.. | 4 25... <i>Carvofseum</i> |
| 24..... | 10A 2.40, 15a 2.10.. | 4 50... <i>Carvofseworm</i> |
| 30..... | 8A 2.65, 12a 2.35.. | 5 00... <i>Carvofshbook</i> |
| 36..... | 6A 2.90, 10a 2.60.. | 5 50... <i>Carvofshbox</i> |

Campaigners. A

Per font..... 1 75...*Carvofseknife*

Cancelled Figures. c

| | |
|-------------------|----------------|
| 8 Pt. No. 40..... | Per lb., 90... |
| 9..... | 40..... 80... |
| 10..... | 40..... 74... |
| 11..... | 40..... 70... |

Card Indicators. A-B

| | | |
|-------------------------------------|-----------|-------------------|
| 6 Pt., complete with Rules, etc.... | \$5 50... | <i>Castorball</i> |
| 12..... | 1 00... | <i>Castorbean</i> |
| 24..... | 1 75... | <i>Castoreum</i> |
| Nos. 82½, 83½, 84½ and 85½, each, | 15... | |
| Set of four..... | 40... | |
| Nos. 918E, 919E, 920E, 921E...each, | 20... | |
| Set of four..... | 50... | |

Card Mercantile. A

| | | |
|------------------|-------------------|---------------------------|
| 6 Pt. No. 1..... | 26A.....per font, | 1 00... <i>Casualism</i> |
| 6..... | 2.....22A..... | 1 00... <i>Casualist</i> |
| 6..... | 3.....20A..... | 1 15... <i>Casualty</i> |
| 6..... | 4.....20A..... | 1 25... <i>Casualness</i> |
| 8..... | 5.....18A..... | 1 50... <i>Casualties</i> |
| 10..... | 6.....16A..... | 1 75... <i>Casualty</i> |
| 12..... | 7.....14A..... | 2 00... <i>Casuarina</i> |
| 18..... | 8.....8A..... | 2 50... <i>Casuarinus</i> |
| 24..... | 9.....6A..... | 2 75... <i>Casuary</i> |
| 30..... | 10.....5A..... | 3 00... <i>Casuist</i> |

CARD ORNAMENTS (see Ornaments).

Card Pips. A

32 Pt. Series 1.....per font, 5 00...*Casualistic*

Carpenter Script. E

| | | |
|------------|-------------------------|---------------------------|
| 22 Pt..... | 8A \$3.10, 32a \$5.40.. | 8 50... <i>Catabasion</i> |
| | 4A 1.60, 16a 2.90.. | 4 50... <i>Catacombs</i> |
| 30..... | 8A 4.00, 32a 8.50.. | 12 50... <i>Catadrome</i> |
| | 4A 2.30, 16a 4.20.. | 6 50... <i>Catadupe</i> |

Caslon Condensed. E

| | | |
|------------|---------------------|---------------------------|
| 18 Pt..... | 8A 1.40, 16a 1.60.. | 3 00... <i>Catamite</i> |
| 24..... | 6A 1.60, 12a 1.90.. | 3 50... <i>Catamound</i> |
| 30..... | 5A 2.10, 10a 2.40.. | 4 50... <i>Catapasm</i> |
| 36..... | 4A 2.50, 8a 2.50.. | 5 00... <i>Catapeltic</i> |
| 48..... | 3A 3.00, 5a 2.50.. | 5 50... <i>Cataphonic</i> |
| 60..... | 3A 4.90, 5a 4.10.. | 9 00... <i>Cataphract</i> |
| | | 9 00... <i>Catapuce</i> |

Caslon O. S. Italic No. 71. c

| | | | |
|------------|----------------------|---------------------------|--------------------------|
| 14 Pt..... | 18A..... | 52a..... | 5 00... <i>Catstasis</i> |
| 18..... | 10A 1.45, 28a 1.95.. | 3 40... <i>Catcheth</i> | |
| 22..... | 8A 1.55, 18a 1.60.. | 3 40... <i>Catchfy</i> | |
| 24..... | 6A 1.65, 14a 1.70.. | 3 35... <i>Catching</i> | |
| 30..... | 5A 1.80, 10a 1.80.. | 3 35... <i>Catchpenny</i> | |
| 36..... | 4A 2.50, 8a 2.10.. | 3 60... <i>Catchpool</i> | |
| 42..... | 4A 2.55, 7a 2.60.. | 4 60... <i>Catchword</i> | |
| 48..... | 3A..... | 5 15... <i>Catechetic</i> | |
| | | 6 05... <i>Catechine</i> | |

Caslon O. S. No. 71. c

| | | | | |
|-----------|---------------------|----------|-----------|---------------------------|
| 6 Pt..... | 15A..... | 25A..... | 170a..... | 6 95... <i>Catechism</i> |
| 8..... | 12A..... | 20A..... | 120a..... | 6 40... <i>Catechu</i> |
| 9..... | 9A..... | 18A..... | 90a..... | 6 95... <i>Catechumen</i> |
| 10..... | 8A..... | 15A..... | 75a..... | 4 80... <i>Categorize</i> |
| 11..... | 7A..... | 14A..... | 70a..... | 4 45... <i>Category</i> |
| 12..... | 6A..... | 12A..... | 60a..... | 4 60... <i>Catena</i> |
| 14..... | 14A..... | 18A..... | 52a..... | 5 25... <i>Catenarian</i> |
| 18..... | 14A..... | 18A..... | 52a..... | 5 25... <i>Catenary</i> |
| 22..... | 10A..... | 14A..... | 28a..... | 8 30... <i>Catenated</i> |
| 24..... | 7A..... | 10A..... | 20a..... | 7 65... <i>Catenulate</i> |
| 30..... | 4A..... | 7A..... | 14a..... | 7 65... <i>Cateran</i> |
| 36..... | 4A..... | 7A..... | 14a..... | 9 35... <i>Caterers</i> |
| 42..... | 5A 4.45, 10a 3.90.. | | | 6 95... <i>Caterwaul</i> |
| 48..... | 4A 5.00, 6a 3.50.. | | | 8 35... <i>Catfall</i> |
| 60..... | 3A 6.65, 4a 3.80.. | | | 8 50... <i>Catfish</i> |
| 72..... | 3A 9.35, 3a 4.70.. | | | 14 05... <i>Catgut</i> |

CAST INITIALS (see Initials).

Caxton Black. c

| | | | |
|-----------|----------------------|----------------|--------------------------|
| 6 Pt..... | 14A..... | .80, 45a .95.. | 1 75... <i>Catkin</i> |
| 8..... | 12A 1.05, 40a 1.10.. | | 1 75... <i>Catmint</i> |
| 9..... | 10A .95, 30a 1.20.. | | 2 15... <i>Catonism</i> |
| 12..... | 10A 1.10, 30a 1.25.. | | 2 15... <i>Catoptric</i> |
| 18..... | 6A 1.30, 18a 1.45.. | | 2 35... <i>Catcradle</i> |
| 30..... | 4A 1.80, 12a 2.00.. | | 2 75... <i>Catsilver</i> |
| 42..... | 3A 2.55, 9a 2.55.. | | 3 80... <i>Catspaw</i> |
| 54..... | 3A 4.85, 5a 2.95.. | | 5 10... <i>Catsup</i> |
| | | | 7 80... <i>Cattle</i> |

Caxton Bold. E

| | | |
|-----------|----------------------|-----------------------------|
| 6 Pt..... | 24A 1.20, 48a 1.40.. | 2 60... <i>Cattleshov</i> |
| 8..... | 24A 1.45, 48a 1.75.. | 3 20... <i>Cavicus</i> |
| 10..... | 20A 1.35, 40a 1.65.. | 3 20... <i>Cavudat</i> |
| 12..... | 18A 1.60, 36a 1.80.. | 3 00... <i>Cavudated</i> |
| 18..... | 10A 1.80, 20a 2.05.. | 3 40... <i>Cavudex</i> |
| 24..... | 8A 2.25, 16a 2.65.. | 3 85... <i>Cavudicle</i> |
| 30..... | 6A 2.60, 12a 3.00.. | 4 90... <i>Cavudicula</i> |
| 36..... | 5A 2.85, 10a 3.65.. | 5 60... <i>Cavudines</i> |
| 48..... | 4A 4.75, 8a 4.75.. | 6 50... <i>Cavyle</i> |
| 60..... | 3A 6.00, 6a 5.75.. | 9 50... <i>Caught</i> |
| 72..... | 3A 8.25, 5a 6.75.. | 11 75... <i>Caulcescent</i> |
| | | 15 00... <i>Cauliculus</i> |

Caxton Borders. A *Cauliform*

| | | |
|--------------------|----------------------|--------------------------|
| 6 Pt. No. 236..... | 54 inches, \$1 50... | <i>Cauline</i> |
| 6..... | 237.....54..... | 1 50... <i>Cupronate</i> |
| 10..... | 238.....40..... | 1 50... <i>Cusable</i> |
| 12..... | 239.....36..... | 1 50... <i>Cusality</i> |
| 18..... | 240.....30..... | 1 50... <i>Cusative</i> |

Caxton Old Style. E *Cauterized*

| | | |
|------------|--------------------------|----------------------------|
| 18 Pt..... | 10A \$1.70, 20a \$1.95.. | 3 65... <i>Cautery</i> |
| 24..... | 8A 2.25, 16a 2.65.. | 4 90... <i>Cautonary</i> |
| 30..... | 6A 2.35, 12a 2.80.. | 5 15... <i>Cautioned</i> |
| 36..... | 5A 3.05, 10a 3.65.. | 6 70... <i>Cautioning</i> |
| 48..... | 4A 4.25, 8a 4.85.. | 9 10... <i>Cautiously</i> |
| 60..... | 3A 5.15, 6a 5.35.. | 10 50... <i>Cavalcade</i> |
| 72..... | 3A 8.40, 5a 7.10.. | 15 50... <i>Cavalierly</i> |

Caxton Old Style Italic. E *Cavalry*

| | | |
|-----------|-----------------------|--------------------------|
| 6 Pt..... | 32A 1.30, 200a 5.40 | 6 70... <i>Cavatina</i> |
| 8..... | 32A 1.65, 200a 6.50.. | 8 15... <i>Caveat</i> |
| 10..... | 24A 1.45, 140a 5.20.. | 6 65... <i>Caveating</i> |
| 12..... | 18A 1.35, 100a 4.35.. | 5 70... <i>Caveator</i> |

Celtic No. 3. D *Ceding*

| | |
|--|---------------------------|
| 6 Pt. 30A \$1.20, 35A 1.35, 40a 1.35.. | 3 90... <i>Cedrine</i> |
| 7.....20A .90, 20A 1.05, 40a 1.05.. | 3 00... <i>Ceduous</i> |
| 8.....20A 1.15, 20A 1.35, 40a 1.35.. | 3 85... <i>Ceinture</i> |
| 10.....18A 1.20, 18A 1.45, 30a 1.45.. | 4 10... <i>Celandine</i> |
| 12.....14A 1.30, 14A 1.50, 20a 1.50.. | 4 30... <i>Celature</i> |
| 18.....10A 1.55, 10A 1.95, 15a 1.95.. | 5 45... <i>Celebrant</i> |
| 24.....8A 2.00, 8A 2.35, 10a 2.35.. | 6 70... <i>Celebrated</i> |

Central Antique. F *Cerastine*

| | | |
|-----------|----------------------|---------------------------|
| 6 Pt..... | 30A 1.15, 42a 1.10.. | 2 25... <i>Cerastines</i> |
| 8..... | 24A 1.35, 36a 1.15.. | 2 50... <i>Cerberium</i> |
| 10..... | 22A 1.50, 30a 1.25.. | 2 75... <i>Cerberus</i> |
| 12..... | 18A 1.70, 22a 1.30.. | 3 00... <i>Cercaria</i> |
| 14..... | 14A 1.75, 20a 1.25.. | 3 00... <i>Cerealia</i> |
| 18..... | 10A 1.75, 16a 1.50.. | 3 25... <i>Cerebel</i> |
| 20..... | 6A 2.10, 10a 1.90.. | 4 00... <i>Cerebellar</i> |
| 30..... | 5A 2.40, 8a 2.10.. | 4 50... <i>Cerebellum</i> |
| 36..... | 4A 2.75, 6a 2.25.. | 5 00... <i>Cerebral</i> |
| 42..... | 4A 3.75, 6a 3.25.. | 7 00... <i>Cerebrics</i> |
| 48..... | 3A 4.50, 5a 3.50.. | 8 00... <i>Cerebrum</i> |
| 54..... | 3A 5.70, 5a 4.30.. | 10 00... <i>Cerecloth</i> |

Central Bands. F *Cerements*

| | |
|-------------------|--------------------------------------|
| 12 Pt. No. 1..... | 24 inches, 75... <i>Ceremonical</i> |
| 12..... | 2.....24.....75... <i>Ceremony</i> |
| 18..... | 1.....24.....1 00... <i>Ceriph</i> |
| 18..... | 2.....24.....1 00... <i>Cerium</i> |
| 24..... | 1.....24.....1 50... <i>Ceroma</i> |
| 24..... | 2.....24.....1 50... <i>Cerovons</i> |

CENTRAL ORNAMENTS (see Ornaments).

Century. A *Certifying*

| | | |
|------------|---------------------|--------------------------|
| 18 Pt..... | 9A 1.65, 14a 1.60.. | 3 25... <i>Certitary</i> |
| 24..... | 6A 2.20, 9a 1.80.. | 4 00... <i>Certitude</i> |
| 36..... | 4A 2.95, 6a 2.05.. | 5 00... <i>Cerutean</i> |

CENTURY ROMAN (sold at Roman prices).

Chamfer Condensed. C *Cetacea*

| | | |
|-----------|----------|---------------------------|
| 6 Pt..... | 52A..... | 2 00... <i>Cetaceous</i> |
| 8..... | 45A..... | 2 00... <i>Ceterach</i> |
| 10..... | 36A..... | 2 00... <i>Cetine</i> |
| 12..... | 36A..... | 2 60... <i>Cetologist</i> |
| 18..... | 30A..... | 3 60... <i>Cetology</i> |
| 24..... | 18A..... | 3 00... <i>Cetrarine</i> |
| 30..... | 14A..... | 4 00... <i>Cetyle</i> |
| 36..... | 10A..... | 3 75... <i>Ceylanite</i> |
| 42..... | 10A..... | 4 90... <i>Ceylonese</i> |
| 48..... | 7A..... | 6 15... <i>Chabasite</i> |
| 60..... | 7A..... | 7 15... <i>Chablis</i> |
| 72..... | 7A..... | 9 90... <i>Chafery</i> |
| 84..... | 5A..... | 10 30... <i>Chafeth</i> |
| 96..... | 5A..... | 12 80... <i>Chafewax</i> |

Chapel Text No. 30. B *Chainshot*

| | | |
|------------|----------------------|---------------------------|
| 10 Pt..... | 15A 2.10, 40a 1.85.. | 3 95... <i>Chainwales</i> |
| 12..... | 12A 2.05, 30a 1.75.. | 3 80... <i>Chainwork</i> |
| 18..... | 10A 2.75, 25a 2.15.. | 4 90... <i>Chairing</i> |
| 24..... | 6A 2.15, 15a 1.70.. | 3 85... <i>Chairman</i> |
| 30..... | 5A 2.80, 12a 2.25.. | 5 05... <i>Chaise</i> |
| 42..... | 4A 3.90, 10a 3.10.. | 7 00... <i>Chalasties</i> |

Checkers. B

| | | |
|------------|-----------------------|---------------------------|
| 11 Pt..... | per font, with rules, | 2 00... <i>Chalky</i> |
| 16..... | “ “ “ | 3 40... <i>Chatybeate</i> |
| 20..... | “ “ “ | 3 40... <i>Chamber</i> |
| 24..... | “ “ “ | 3 40... <i>Chambering</i> |

Chelsea Circular. E *Chamois*

| | | |
|-----------|--------------------------|----------------------------|
| 6 Pt..... | 24A \$1.25, 80a \$2.75.. | \$4 00... <i>Champagne</i> |
| 8..... | 24A 1.40, 80a 3.10.. | 4 50... <i>Champertor</i> |
| 10..... | 18A 1.25, 60a 2.25.. | 3 50... <i>Champeth</i> |
| 12..... | 12A 1.15, 40a 1.85.. | 3 00... <i>Champing</i> |
| 18..... | 9A 1.65, 30a 3.35.. | 5 00... <i>Chanceably</i> |

Chessmen. B *Changeable*

| | | |
|------------|-----------------------|---------------------------|
| 16 Pt..... | per font, with rules, | 4 80... <i>Changeful</i> |
| 20..... | “ “ “ | 4 80... <i>Changeless</i> |
| 24..... | “ “ “ | 4 80... <i>Changeling</i> |

Chicago Script. E *Chaperon*

| | | |
|------------|---------------------|----------------------------|
| 18 Pt..... | 12A 48a..... | 10 75... <i>Chapfallen</i> |
| | 6A 2.15, 16a 2.15.. | 4 30... <i>Chaplain</i> |
| 24..... | 8A 36a..... | 11 75... <i>Chaplaincy</i> |
| | 4A 2.35, 12a 2.35.. | 4 70... <i>Chaplets</i> |
| 36..... | 5A 25a..... | 15 30... <i>Chapmen</i> |
| | 3A 8a..... | 6 00... <i>Chappy</i> |

Childs. C *Charges*

| | | |
|------------|----------------------|----------------------------|
| 12 Pt..... | 20A 2.00, 30a 1.60.. | 3 60... <i>Charity</i> |
| 18..... | 12A 2.30, 18a 1.80.. | 4 10... <i>Chariness</i> |
| 24..... | 8A 2.55, 12a 1.95.. | 4 50... <i>Chariot</i> |
| 30..... | 6A 3.00, 9a 2.15.. | 5 15... <i>Charioteer</i> |
| 36..... | 5A 3.70, 8a 2.60.. | 6 30... <i>Chariotman</i> |
| 48..... | 4A 4.75, 6a 3.60.. | 8 35... <i>Charism</i> |
| 60..... | 3A 6.30, 5a 4.35.. | 10 65... <i>Charitable</i> |

CHRISTMAS ORNAMENTS (see Ornaments).

Circular Commercial. E

| | | |
|---------------------------------------|-----------------------------|---------------------------|
| 8 Pt. 25A .65, 60A 2.75, 350a 8.10.. | 11 50... <i>Charities</i> | |
| | 20A 30a..... | 1 75... <i>Charitous</i> |
| 10.....25A .85, 60A 3.25, 250a 8.15.. | 12 25... <i>Charity</i> | |
| | 16A 24a..... | 1 80... <i>Charivari</i> |
| 12.....20A .75, 48A 3.35, 200a 7.15.. | 11 25... <i>Chark</i> | |
| | 12A 20a..... | 1 80... <i>Charlatan</i> |
| 18.....10A .90, 20A 2.75, 125a 8.10.. | 11 75... <i>Charlatanic</i> | |
| | 10A 16a..... | 2 50... <i>Charlocks</i> |
| 30.....5A .75, 10A 2.25, 42a 6.75.. | 9 75... <i>Churmer</i> | |
| | 6A 12a..... | 3 65... <i>Charmingly</i> |

Circular Gothic No. 120. E *Chatwood*

| | | |
|-----------|-----------------------|---------------------------|
| 8 Pt..... | 24A .95, 144a 3.45.. | 4 40... <i>Chaudron</i> |
| | 24A .95, 48a 1.15.. | 2 10... <i>Chayroot</i> |
| 10..... | 24A 1.10, 144a 4.05.. | 5 15... <i>Cheapened</i> |
| | 24A 1.10, 48a 1.35.. | 2 45... <i>Cheaping</i> |
| 12..... | 18A 1.15, 108a 3.90.. | 5 05... <i>Cheaters</i> |
| | 18A 1.15, 36a 1.30.. | 2 45... <i>Cheatingly</i> |
| 18..... | 12A 1.25, 48a 2.80.. | 4 05... <i>Chebacco</i> |
| | 12A 1.25, 24a 1.40.. | 2 65... <i>Checkbook</i> |
| 24..... | 10A 1.50, 40a 3.40.. | 4 90... <i>Checkers</i> |
| | 10A 1.50, 20a 1.70.. | 3 20... <i>Checkless</i> |

Circular Italic No. 120. E *Checkroll*

| | | |
|-----------|-----------------------|---------------------------|
| 8 Pt..... | 32A 1.40, 200a 4.95.. | 6 35... <i>Ceddar</i> |
| 10..... | 24A 1.45, 140a 4.50.. | 5 95... <i>Cheekbone</i> |
| 12..... | 18A 1.50, 100a 3.90.. | 5 40... <i>Cheektooth</i> |
| 18..... | 10A 1.40, 50a 3.25.. | 4 65... <i>Cheerful</i> |
| 24..... | 10A 1.80, 50a 4.30.. | 6 10... <i>Cheerfully</i> |

Circular Quads. B

| | |
|---------------|--------------------------|
| Per font..... | 3 50... <i>Cheesevat</i> |
|---------------|--------------------------|

Circular Script. C *Chelonia*

| | | |
|------------|-----------------------|----------------------------|
| 12 Pt..... | 10A 50a 4.80.. | 7 00... <i>Chemically</i> |
| 18..... | 10A 50a 8.65.. | 12 20... <i>Chemise</i> |
| 24..... | 10A 50a 13.15.. | 18 65... <i>Chemisette</i> |

Clarendon No. 120. E *Childish*

| | | |
|-----------|----------------------|----------------------------|
| 6 Pt..... | 24A .90, 48a 1.15.. | 2 05... <i>Childishly</i> |
| 8..... | 24A 1.15, 48a 1.35.. | 2 50... <i>Childless</i> |
| 9..... | 18A .95, 36a 1.05.. | 2 00... <i>Childlike</i> |
| 10..... | 18A 1.20, 36a 1.30.. | 2 50... <i>Children</i> |
| 11..... | 16A 1.10, 32a 1.30.. | 2 40... <i>Childiads</i> |
| 12..... | 16A 1.30, 32a 1.65.. | 2 95... <i>Childiagon</i> |
| 18..... | 10A 1.35, 20a 1.60.. | 2 95... <i>Childiarch</i> |
| 24..... | 8A 1.55, 16a 1.80.. | 3 35... <i>Childiasm</i> |
| 30..... | 6A 1.95, 12a 2.20.. | 4 15... <i>Childiastic</i> |
| 36..... | 5A 3.05, 10a 3.35.. | 6 40... <i>Chilled</i> |
| 48..... | 4A 4.10, 8a 4.20.. | 8 30... <i>Chilling</i> |

Clarendon Cond. No. 10. A

| | | |
|---------|--------------------|----------------------------|
| 60..... | 3A 6.16, 4a 3.50.. | 9 66... <i>Chirromancy</i> |
|---------|--------------------|----------------------------|

Clarendon Cond. No. 120. E Chiroplast

Table with columns for size (Pt., 12., 18., 24., 30., 36., 42., 48.), style (18A, 16A, 12A, 10A, 8A, 6A, 5A, 4A), and price. Includes styles like Chirpeth, Chirpingly, Chirrup, Chirurgeon, Chirurgic, Chisel, Chiselled, Chiselling, Chistley, Chitchat, Chittinous, Chittler, Chivatric, Chivalrous, Chlamys, and Chorlat.

Clarendon Cond. No. 122. E Chloridate

Table with columns for size (Pt., 24., 36., 48., 60.), style (12A, 8A, 6A, 4A, 3A), and price. Includes styles Chloriodic, Chloris, Chloroform, Chlorophyll, and Chlorosis.

Clarendon Lightface No. 30. B Chorally

Table with columns for size (Pt., 6., 8., 9., 10., 12., 30., 36.), style (30A, 25A, 30A, 30A, 20A, 8A, 6A), and price. Includes styles Chords, Choriamb, Choriambus, Choristers, Choristic, Choroid, Choruses, and Chosen.

CLASSIC ORNAMENTS (see Ornaments).

Cleveland Script. E Christian

Table with columns for size (Pt.), style (8A, 4A), and price. Includes styles Christmas and Chromate.

Collins Bands. A

Large table with columns for size (Pt. No.), width (inches), and price. Includes styles Ciconia, Cicurate, Cicuration, Ciderist, Ciderkins, Cigarette, Cigars, Ciliated, Ciliograde, Cillosis, Cimeliarch, Cimeter, Cimmerician, Cinchona, Cinchonine, Cinchurine, Cinemantic, Cineration, Cinerulent, Cingalese, Cinnabar, Cinnamonomic, Cinnamon, Cinnamule, Cinque, Cinquepace, Ciphered, Ciphering, Cincar, Circean, Circensial, Circinate, Circling, Circuit, Circuitous, Circularly, Circulates, Circuline, Circum, Circumcise, and Circumduce.

Collins Borders. A

Table with columns for size (Pt.), width (inches), and price. Includes styles Circumfer, Cirrigate, Cirriped, and Cirsocele.

Collins Borders—Continued.

Table with columns for size (Pt. No.), width (inches), and price. Includes styles Cisalpine, Cispadane, Cistercian, Cisterns, Citable, Citadels, Citation, and Citatory.

Collins Florets. A

Table with columns for group (M, N, O, P, Q, R, V, W, X, Y), character count, and price. Includes styles Civilian, Claimable, and Claimants.

SINGLE CHARACTERS.

Table with columns for No., character count, and price. Lists individual characters from No. 143 to 278.

Columbian. c Classible

Table with columns for size (Pt.), style (8A, 6A, 5A, 4A, 3A), price, and price. Includes styles Classical, Classicism, Classics, Classified, and Classman.

Columbus No. 2. c Classmates

Table with columns for size (Pt.), style (35A, 30A, 26A, 25A, 18A, 15A, 10A, 5A, 3A), price, and price. Includes styles Clashingly, Claspeth, Claspknife, Clasplocks, Classes, Clattering, Claudicant, Claudicate, Claustral, and Clavering.

Columbus Initials. c Claviger

Table with columns for size (Pt.), style (3A), and price. Includes styles Clayish, Claymore, and Cleanliest.

Columbus Outline. c*Cleanly*

| | | | |
|------------|--------------------------|-----------|------------------|
| 18 Pt..... | 15A \$3.45, 20a \$2.65.. | \$6 10... | <i>Cleanseth</i> |
| 24..... | 10A 3.90, 15a 3.15.. | 7 05... | <i>Cleansing</i> |
| 36..... | 5A 4.35, 8a 3.65.. | 8 00... | <i>Clearage</i> |
| 48..... | 3A 5.60, 5a 3.75.. | 9 35... | <i>Clearer</i> |
| 60..... | 3A 7.80, 4a 4.55.. | 12 35... | <i>Clearness</i> |

Columbus Outline Initials. c*Cleavable*

| | | | |
|------------|---------|---------|-------------------|
| 36 Pt..... | 3A..... | 2 00... | <i>Cledgy</i> |
| 48..... | 3A..... | 3 00... | <i>Cleftgraft</i> |
| 60..... | 3A..... | 4 00... | <i>Clematites</i> |

Combination Border Series 98. c

| | | | |
|--------------------|-----------|---------|------------------|
| First Section..... | per font, | 6 00... | <i>Clinics</i> |
| Third Section..... | per font, | 5 00... | <i>Clinodome</i> |

Combination Cond. Gothic. A*Clothier*

| | | | |
|------------------|----------------|---------|-------------------|
| 6 Pt. No. 161 .. | 50A..... | 1 25... | <i>Clothing</i> |
| 6..... | 162 ..40A..... | 1 25... | <i>Clotty</i> |
| 6..... | 163 ..32A..... | 1 50... | <i>Cloudage</i> |
| 12..... | 164 ..24A..... | 1 25... | <i>Cloudberry</i> |
| 12..... | 165 ..18A..... | 1 25... | <i>Cloudborn</i> |
| 12..... | 166 ..16A..... | 1 50... | <i>Cloudcapt</i> |

Combination Gothic. A*Clouchain*

| | | | |
|------------------|----------------|---------|---------------------|
| 6 Pt. No. 110 .. | 36A..... | 1 25... | <i>Cloutchart</i> |
| 6..... | 111 ..36A..... | 1 25... | <i>Cloutcharge</i> |
| 6..... | 112 ..32A..... | 1 50... | <i>Cloutchase</i> |
| 6..... | 113 ..32A..... | 1 50... | <i>Cloutchased</i> |
| 12..... | 114 ..18A..... | 1 50... | <i>Cloutchasher</i> |
| 12..... | 115 ..14A..... | 1 50... | <i>Cloutchasing</i> |
| 12..... | 116 ..12A..... | 1 50... | <i>Clouddrift</i> |
| 18..... | 117 ..10A..... | 2 00... | <i>Cloudfull</i> |
| 18..... | 118 ..8A..... | 2 00... | <i>Cloudfloor</i> |
| 24..... | 119 ..6A..... | 2 00... | <i>Cloudhut</i> |
| 24..... | 120 ..6A..... | 2 00... | <i>Cloudier</i> |

Combination Gothic. F*Cloudiest*

| | | | |
|------------------|----------------|---------|--------------------|
| 6 Pt. No. 151 .. | 55A..... | 1 25... | <i>Cloudily</i> |
| 6..... | 152 ..50A..... | 1 25... | <i>Clouddiness</i> |
| 6..... | 153 ..42A..... | 1 50... | <i>Cloudless</i> |
| 6..... | 154 ..42A..... | 1 50... | <i>Cloudlet</i> |
| 6..... | 155 ..32A..... | 1 50... | <i>Clouds</i> |
| 12..... | 156 ..24A..... | 1 25... | <i>Clout</i> |
| 12..... | 157 ..18A..... | 1 25... | <i>Clouted</i> |
| 12..... | 158 ..16A..... | 1 50... | <i>Clouterty</i> |
| 12..... | 159 ..16A..... | 1 50... | <i>Cloutmail</i> |

Combination Gothic. F*Clovente*

| | | | |
|------------------|----------------|---------|--------------------|
| 6 Pt. No. 1529.. | 45A..... | 1 40... | <i>Clovehitch</i> |
| 6..... | 1530..45A..... | 1 50... | <i>Cloven</i> |
| 6..... | 1531..42A..... | 1 60... | <i>Clovepink</i> |
| 6..... | 1532..40A..... | 1 75... | <i>Clovered</i> |
| 6..... | 1533..40A..... | 2 00... | <i>Clovenery</i> |
| 12..... | 1521..30A..... | 2 25... | <i>Clovenish</i> |
| 12..... | 1522..24A..... | 2 25... | <i>Clovenishly</i> |
| 12..... | 1523..24A..... | 2 25... | <i>Cloying</i> |
| 12..... | 1524..20A..... | 2 25... | <i>Cloyment</i> |
| 18..... | 1525..14A..... | 2 40... | <i>Clubbed</i> |
| 18..... | 1526..12A..... | 2 50... | <i>Clubfist</i> |
| 24..... | 1527..8A..... | 3 00... | <i>Clubfooted</i> |
| 24..... | 1528..8A..... | 3 00... | <i>Clubgrass</i> |

Combination Italic Gothic. A*Clubhaul*

| | | | |
|------------------|----------------|---------|--------------------|
| 6 Pt. No. 131 .. | 40A..... | 1 35... | <i>Clubheaded</i> |
| 6..... | 132 ..30A..... | 1 35... | <i>Clubhouse</i> |
| 12..... | 133 ..24A..... | 1 40... | <i>Clublaw</i> |
| 12..... | 134 ..20A..... | 1 40... | <i>Clubman</i> |
| 12..... | 135 ..16A..... | 1 40... | <i>Clubmoss</i> |
| 18..... | 136 ..14A..... | 2 00... | <i>Clubroom</i> |
| 24..... | 137 ..10A..... | 2 25... | <i>Clumps</i> |
| 24..... | 138 ..8A..... | 2 50... | <i>Clumsiest</i> |
| 36..... | 149 ..6A..... | 3 40... | <i>Clumstiness</i> |
| 48..... | 150 ..4A..... | 4 00... | <i>Clumtsy</i> |

COMBINATION ORNAMENTS, SERIES K

(see Ornaments).

Commercial Signs No. 150. F

| | | | |
|------------|----------|---------|-------------------|
| 5½ Pt..... | per lb., | 2 40... | <i>Cockatrice</i> |
| 6..... | | 2 00... | <i>Cockbill</i> |
| 7..... | | 1 80... | <i>Cockboat</i> |
| 8..... | | 1 60... | <i>Cockchafer</i> |
| 9..... | | 1 44... | <i>Cockcrow</i> |
| 10..... | | 1 30... | <i>Cockerel</i> |
| 11..... | | 1 22... | <i>Cockering</i> |
| 12..... | | 1 16... | <i>Cockeye</i> |

Composite No. 30. B

| | | | |
|------------|----------------------|---------|-------------------|
| 10 Pt..... | 15A 1.15, 40a 1.40.. | 2 55... | <i>Cockneyism</i> |
|------------|----------------------|---------|-------------------|

Composite No. 150. F*Coddymoddy*

| | | | |
|------------|--------------------------|-----------|-------------------|
| 12 Pt..... | 16A \$1.85, 50a \$2.65.. | \$4 50... | <i>Codetta</i> |
| 14..... | 10A 1.40, 30a 2.10.. | 3 50... | <i>Codex</i> |
| 18..... | 10A 1.65, 25a 2.60.. | 4 25... | <i>Codexes</i> |
| 24..... | 8A 2.20, 20a 3.55.. | 5 75... | <i>Codfish</i> |
| 30..... | 6A 3.30, 15a 3.45.. | 6 75... | <i>Codfishers</i> |

Composite Condensed. B*Cockspurs*

| | | | |
|------------|----------------------|---------|------------------|
| 12 Pt..... | 15A 1.75, 40a 2.25.. | 4 00... | <i>Cockswain</i> |
| 18..... | 10A 2.00, 25a 2.25.. | 4 25... | <i>Cockswain</i> |
| 30..... | 5A 2.25, 12a 2.15.. | 4 40... | <i>Cocoon</i> |
| 42..... | 4A 3.00, 10a 3.00.. | 6 00... | <i>Cocoonery</i> |

Condensed No. 45. c

| | | | |
|-------------|---------|---------|-------------------|
| *72 Pt..... | 5A..... | 9 85... | <i>Confronted</i> |
|-------------|---------|---------|-------------------|

Condensed No. 124. E*Confucian*

| | | | |
|-----------|----------|---------|-------------------|
| 6 Pt..... | 36A..... | 1 30... | <i>Confusable</i> |
| 8..... | 24A..... | 1 15... | <i>Confuse</i> |
| 10..... | 24A..... | 1 35... | <i>Confusedly</i> |
| 11..... | 24A..... | 1 50... | <i>Confusing</i> |
| 12..... | 24A..... | 1 85... | <i>Confuters</i> |
| 16..... | 18A..... | 2 00... | <i>Congeaed</i> |
| 18..... | 16A..... | 2 00... | <i>Congener</i> |
| 24..... | 12A..... | 2 20... | <i>Congeneric</i> |
| 30..... | 10A..... | 2 80... | <i>Congenious</i> |
| 36..... | 6A..... | 2 70... | <i>Congenital</i> |
| 42..... | 5A..... | 2 90... | <i>Congenite</i> |
| 48..... | 4A..... | 4 05... | <i>Congerics</i> |

Condensed Aldine No. 150. F*Colloquialism*

| | | | |
|-----------|----------------------|---------|--------------------|
| 6 Pt..... | 30A .95, 60a 1.05.. | 2 00... | <i>Colloqually</i> |
| 7..... | 36A 1.20, 50a 1.05.. | 2 25... | <i>Colloquist</i> |
| 8..... | 26A 1.50, 38a 1.30.. | 2 80... | <i>Colloquy</i> |
| 9..... | 24A 1.45, 36a 1.45.. | 2 90... | <i>Collow</i> |
| 10..... | 24A 1.60, 36a 1.40.. | 3 00... | <i>Collude</i> |
| 11..... | 24A 1.55, 36a 1.45.. | 3 00... | <i>Collusion</i> |
| 12..... | 22A 1.80, 32a 1.70.. | 3 50... | <i>Collusive</i> |
| 14..... | 18A 2.00, 26a 1.75.. | 3 75... | <i>Collusory</i> |
| 18..... | 18A 2.00, 26a 2.00.. | 4 00... | <i>Colluvies</i> |
| 20..... | 12A 2.25, 16a 1.75.. | 4 00... | <i>Collybist</i> |
| 30..... | 10A 2.00, 15a 2.00.. | 4 00... | <i>Collyrium</i> |
| 36..... | 10A 2.90, 15a 3.10.. | 6 00... | <i>Colocynth</i> |
| 48..... | 6A 3.10, 10a 3.20.. | 6 30... | <i>Cologne</i> |
| 60..... | 5A 3.65, 7a 3.35.. | 7 00... | <i>Colon</i> |
| 72..... | 4A 4.00, 6a 4.00.. | 8 00... | <i>Colonelcy</i> |

Condensed Black No. 42. c*Comforting*

| | | | |
|------------|----------------------|---------|-------------------|
| 10 Pt..... | 20A 2.10, 52a 2.45.. | 4 55... | <i>Comfrey</i> |
| 12..... | 12A 1.85, 32a 2.10.. | 3 95... | <i>Comical</i> |
| 18..... | 12A 2.45, 32a 3.05.. | 5 50... | <i>Command</i> |
| 24..... | 8A 2.35, 20a 2.85.. | 5 20... | <i>Commandant</i> |
| 30..... | 6A 2.95, 14a 3.05.. | 6 00... | <i>Commandery</i> |
| 36..... | 6A 3.90, 14a 3.85.. | 7 75... | <i>Commandeth</i> |

Cond. Black Shaded No. 40. c*Commode*

| | | | | |
|------------|-----------|-----------|---------|-------------------|
| 10 Pt..... | 20A | 52a | 4 55... | <i>Commodious</i> |
| 12..... | 12A | 32a | 4 00... | <i>Commodity</i> |
| 18..... | 12A | 32a | 5 75... | <i>Commodore</i> |
| 24..... | 8A | 20a | 5 10... | <i>Commonage</i> |
| 30..... | 6A | 14a | 6 00... | <i>Commonalty</i> |
| 36..... | 6A | 14a | 7 90... | <i>Commoners</i> |

Cond. Clarendon No. 42. c*Compilers*

| | | | |
|-----------|----------------------|---------|--------------------|
| 6 Pt..... | 52A 1.35, 70a 1.15.. | 2 50... | <i>Compiling</i> |
| 8..... | 36A 1.30, 70a 1.45.. | 2 75... | <i>Complacent</i> |
| 10..... | 36A 1.40, 52a 1.30.. | 2 70... | <i>Complained</i> |
| 12..... | 25A 1.45, 42a 1.30.. | 2 75... | <i>Complaiante</i> |

Cond. Germ. Black No. 150. F*Compulsory*

| | | | |
|------------|----------------------|---------|------------------|
| 12 Pt..... | 16A 2.10, 50a 2.40.. | 4 50... | <i>Compunct</i> |
| 18..... | 8A 1.70, 20a 1.80.. | 3 50... | <i>Compupil</i> |
| 24..... | 4A 1.25, 10a 1.25.. | 2 50... | <i>Computeth</i> |
| 30..... | 4A 1.60, 10a 1.90.. | 3 50... | <i>Computing</i> |

Condensed Title No. 46. c

| | | | |
|-------------|--------------------|----------|----------------|
| *72 Pt..... | 5A 9.85, 6a 7.10.. | 16 95... | <i>Context</i> |
|-------------|--------------------|----------|----------------|

Condensed Title No. 104. d*Contingent*

| | | | |
|-----------|----------------------|---------|-------------------|
| 6 Pt..... | 36A 1.30, 70a 1.30.. | 2 60... | <i>Continueth</i> |
| 8..... | 36A 1.65, 70a 1.60.. | 3 25... | <i>Continuing</i> |
| 10..... | 36A 1.95, 70a 1.90.. | 3 85... | <i>Continuity</i> |
| 12..... | 25A 1.85, 52a 1.80.. | 3 65... | <i>Contorsion</i> |
| 18..... | 18A 1.80, 27a 1.75.. | 3 55... | <i>Contortive</i> |
| 24..... | 14A 2.30, 27a 2.30.. | 4 60... | <i>Contour</i> |
| 30..... | 14A 3.15, 20a 3.15.. | 6 30... | <i>Contra</i> |

Condensed Title No. 123. E Contraband

| | | | | | | |
|-----------|-----|---------|-----|----------|-----------|---------------------|
| 5 Pt..... | 32A | \$1.10, | 64a | \$1.30.. | \$2 40... | <i>Contradict</i> |
| 6..... | 24A | .85, | 48a | 1.10.. | 1 95... | <i>Contrahent</i> |
| 8..... | 24A | 1.10, | 48a | 1.40.. | 2 50... | <i>Contratto</i> |
| 10..... | 24A | 1.30, | 48a | 1.65.. | 2 95... | <i>Contramure</i> |
| 12..... | 18A | 1.40, | 36a | 1.70.. | 3 10... | <i>Contrapose</i> |
| 14..... | 12A | 1.25, | 24a | 1.35.. | 2 60... | <i>Contrary</i> |
| 18..... | 10A | 1.45, | 20a | 1.60.. | 3 05... | <i>Contrasted</i> |
| 24..... | 12A | 2.20, | 24a | 2.55.. | 4 75... | <i>Contravene</i> |
| 30..... | 8A | 2.60, | 16a | 2.90.. | 5 50... | <i>Contribute</i> |
| 36..... | 6A | 3.30, | 12a | 3.85.. | 7 15... | <i>Contrite</i> |
| 42..... | 5A | 3.50, | 10a | 4.05.. | 7 55... | <i>Contritely</i> |
| *48..... | 4A | 3.75, | 6a | 3.25.. | 7 00... | <i>Contribution</i> |
| *54..... | 4A | 3.10, | 5a | 4.90.. | 8 00... | <i>Contrived</i> |

Condensed Title No. 124. E Contrivers

| | | | | | | |
|-----------|-----|-------|-----|--------|---------|-------------------|
| 6 Pt..... | 24A | .90, | 48a | 1.15.. | 2 05... | <i>Contriving</i> |
| 7..... | 24A | .90, | 48a | 1.15.. | 2 05... | <i>Controlled</i> |
| 8..... | 24A | 1.15, | 48a | 1.35.. | 2 50... | <i>Controls</i> |
| 9..... | 24A | 1.30, | 48a | 1.45.. | 2 75... | <i>Controvert</i> |
| 10..... | 24A | 1.45, | 48a | 1.85.. | 3 30... | <i>Contumacy</i> |
| 11..... | 18A | 1.20, | 36a | 1.40.. | 2 60... | <i>Contumely</i> |
| 12..... | 18A | 1.40, | 36a | 1.65.. | 3 05... | <i>Contusions</i> |
| 14..... | 18A | 1.75, | 36a | 1.95.. | 3 70... | <i>Conundrum</i> |

Condensed Title No. 125. E Conusable

| | | | | | | |
|-----------|-----|-------|-----|--------|---------|-------------------|
| 6 Pt..... | 24A | .90, | 48a | 1.15.. | 2 05... | <i>Convalesce</i> |
| 7..... | 24A | .90, | 48a | 1.10.. | 2 00... | <i>Convective</i> |
| 8..... | 24A | 1.15, | 48a | 1.40.. | 2 55... | <i>Convenced</i> |
| 9..... | 24A | 1.10, | 48a | 1.40.. | 2 50... | <i>Convenient</i> |
| 10..... | 24A | 1.35, | 48a | 1.65.. | 3 00... | <i>Convening</i> |
| 11..... | 18A | 1.10, | 36a | 1.30.. | 2 40... | <i>Convents</i> |
| 12..... | 18A | 1.25, | 36a | 1.50.. | 2 75... | <i>Converge</i> |
| 14..... | 18A | 1.45, | 36a | 1.80.. | 3 25... | <i>Converging</i> |
| 18..... | 12A | 1.45, | 24a | 1.80.. | 3 25... | <i>Conversant</i> |
| 24..... | 12A | 1.80, | 24a | 2.20.. | 4 00... | <i>Conversely</i> |
| 30..... | 10A | 2.30, | 20a | 2.60.. | 4 90... | <i>Converseth</i> |
| 36..... | 8A | 2.95, | 16a | 3.65.. | 6 00... | <i>Conversion</i> |
| 48..... | 4A | 3.00, | 8a | 3.40.. | 6 40... | <i>Conversive</i> |
| 60..... | 3A | 4.25, | 6a | 4.10.. | 8 35... | <i>Convertite</i> |

Contour No. 1. E

| | | | | | | |
|------------|-----|-------|-----|--------|---------|-------------------|
| 12 Pt..... | 16A | 1.45, | 32a | 1.80.. | 3 25... | <i>Convulsed</i> |
| 16..... | 10A | 1.55, | 20a | 1.90.. | 3 45... | <i>Convulsive</i> |
| 20..... | 10A | 2.25, | 20a | 2.75.. | 5 00... | <i>Coycatch</i> |
| 24..... | 8A | 2.20, | 16a | 2.80.. | 5 00... | <i>Cookmaid</i> |
| 30..... | 6A | 2.35, | 12a | 2.80.. | 5 15... | <i>Coolcup</i> |
| 36..... | 5A | 3.10, | 10a | 3.80.. | 6 90... | <i>Coolheaded</i> |
| 48..... | 4A | 4.10, | 8a | 4.70.. | 8 80... | <i>Cooling</i> |

Contour No. 2. E

| | | | | | |
|------------|----|-------|-------|---------|-------------------|
| 18 Pt..... | 8A | | | 1 65... | <i>Coolly</i> |
| 24..... | 6A | | | 1 90... | <i>Coolness</i> |
| 36..... | 4A | | | 3 30... | <i>Coombe</i> |
| 48..... | 3A | | | 4 70... | <i>Cooperates</i> |

Contour No. 3. E

| | | | | | |
|------------|----|-------|-------|---------|-------------------|
| 18 Pt..... | 6A | | | 2 25... | <i>Coopers</i> |
| 24..... | 6A | | | 4 25... | <i>Coordinate</i> |
| 36..... | 3A | | | 5 75... | <i>Copaibas</i> |

Contour No. 4. E

| | | | | | | |
|------------|----|-------|-----|--------|----------|-------------------|
| 30 Pt..... | 6A | 1.80, | 12a | 2.20.. | 4 00... | <i>Coparceny</i> |
| 36..... | 5A | 2.20, | 10a | 2.70.. | 4 90... | <i>Copartner</i> |
| 42..... | 4A | 2.80, | 8a | 3.20.. | 6 00... | <i>Copemen</i> |
| 48..... | 4A | 3.80, | 8a | 4.40.. | 8 20... | <i>Copernican</i> |
| 60..... | 3A | 5.00, | 5a | 5.45.. | 9 45... | <i>Copesmate</i> |
| 72..... | 3A | 6.40, | 5a | 5.55.. | 11 95... | <i>Copestone</i> |

Contour No. 5. E

| | | | | | |
|------------|----|-------|-------|---------|------------------|
| 24 Pt..... | 6A | | | 2 35... | <i>Copiosis</i> |
| 36..... | 4A | | | 4 00... | <i>Coping</i> |
| 48..... | 3A | | | 5 40... | <i>Copiously</i> |

Contour No. 6. E

| | | | | | |
|------------|-----|-------|-------|---------|-------------------|
| 12 Pt..... | 32A | | | 2 00... | <i>Coplant</i> |
| 18..... | 18A | | | 2 10... | <i>Copartner</i> |
| 24..... | 12A | | | 2 25... | <i>Copperas</i> |
| 32..... | 8A | | | 2 75... | <i>Copperhead</i> |
| 42..... | 5A | | | 2 70... | <i>Copperish</i> |
| 48..... | 4A | | | 3 20... | <i>Copperose</i> |
| 60..... | 3A | | | 3 75... | <i>Coppice</i> |
| 72..... | 3A | | | 5 40... | <i>Coppiedust</i> |

Contour No. 7. E

| | | | | | | |
|------------|----|-------|-----|--------|---------|-----------------|
| 36 Pt..... | 5A | 1.50, | 10a | 1.85.. | 3 35... | <i>Copses</i> |
| 48..... | 4A | 2.05, | 8a | 2.35.. | 4 40... | <i>Copula</i> |
| 60..... | 3A | 2.95, | 6a | 2.95.. | 5 90... | <i>Copyhook</i> |
| 72..... | 3A | 3.80, | 6a | 4.05.. | 7 85... | <i>Copyhold</i> |

Contour Bands and Borders. A

| | | | |
|--------------------|------------|-----------|----------------------------|
| 6 Pt. No. 272..... | 54 inches, | \$1 50... | <i>Copyism</i> |
| 6..... | 278..... | 54..... | 1 50... <i>Copyist</i> |
| 9..... | 279..... | 46..... | 1 50... <i>Copyists</i> |
| 9..... | 280..... | 46..... | 1 50... <i>Copyopia</i> |
| 10..... | 273..... | 40..... | 1 50... <i>Copyright</i> |
| 12..... | 274..... | 36..... | 1 50... <i>Copyrighted</i> |
| 16..... | 264..... | 30..... | 1 50... <i>Copyweb</i> |
| 16..... | 267..... | 30..... | 1 50... <i>Coque</i> |
| 18..... | 257..... | 30..... | 1 50... <i>Coquet</i> |
| 18..... | 258..... | 30..... | 1 50... <i>Coquetoon</i> |
| 18..... | 261..... | 30..... | 1 50... <i>Coquetry</i> |
| 18..... | 265..... | 30..... | 1 50... <i>Coquette</i> |
| 18..... | 269..... | 30..... | 1 50... <i>Coracles</i> |
| 18..... | 270..... | 30..... | 1 50... <i>Coralheads</i> |
| 18..... | 271..... | 30..... | 1 50... <i>Coralbush</i> |
| 18..... | 275..... | 30..... | 1 50... <i>Coralline</i> |
| 24..... | 259..... | 20..... | 1 50... <i>Coralloid</i> |
| 24..... | 260..... | 20..... | 1 50... <i>Coralloides</i> |
| 24..... | 266..... | 20..... | 1 50... <i>Corallum</i> |
| 24..... | 268..... | 20..... | 1 50... <i>Corabrag</i> |
| 30..... | 263..... | 20..... | 1 50... <i>Coralreef</i> |
| 36..... | 262..... | 18..... | 1 50... <i>Corabroad</i> |
| 36..... | 298..... | 18..... | 1 50... <i>Coralroot</i> |
| 42..... | 296..... | 12..... | 1 50... <i>Corals</i> |
| 42..... | 297..... | 12..... | 1 50... <i>Coraltree</i> |
| 48..... | 295..... | 12..... | 1 50... <i>Coralwall</i> |

CONTOUR PALMETTO ORNAMENTS (see Ornaments).

CONTOUR POINTERS (see Pointers).

COPPER ALLOY FINE-DOT LEADERS (see Leaders).

Copper Alloy Imprints. F

| | | |
|--------------------------|------|---------|
| 100 of any one kind..... | net, | 8 00... |
| 50..... | " | 5 00... |

If Imprints are wanted longer than one and one-fourth inches in length, they will have to be made in two or more pieces, and \$3.00 extra per hundred will be charged for each extra piece.

COPPER-ALLOY TAKE SLUGS (see Take Slugs).

Copperplate Roman. F

| | | | |
|------------------|----------|----------|---------------------------|
| 6 Pt. No. 1..... | 30A..... | 1 25... | <i>Corduroy</i> |
| 6..... | 2..... | 60A..... | 1 75... <i>Cordwainer</i> |
| 6..... | 3..... | 60A..... | 1 75... <i>Cordwood</i> |
| 8..... | | 25A..... | 2 75... <i>Coregents</i> |
| 10..... | | 20A..... | 3 00... <i>Corelative</i> |

Coppers. F

| | | | |
|---------------|-------|---------|-----------------|
| Per font..... | | 1 50... | <i>Corindon</i> |
|---------------|-------|---------|-----------------|

Coptic Borders. A

| | | | |
|-------------------|------------|---------|-------------------|
| 24 Pt. No. 4..... | 20 inches, | 1 50... | <i>Corinthiac</i> |
| 36..... | 18..... | 1 50... | <i>Corivalry</i> |

CORNER QUADS (see Metal Corner Quads).

Crayon. C

| | | | | | | |
|------------|----|---------|-----|----------|---------|------------------|
| 18 Pt..... | 5A | \$2.05, | 12a | \$2.00.. | 4 05... | <i>Cornific</i> |
| 24..... | 5A | 3.00, | 10a | 2.15.. | 5 15... | <i>Cornloft</i> |
| 36..... | 3A | 4.20, | 5a | 2.10.. | 6 30... | <i>Cornmeter</i> |

Cruikshank. C

| | | | | | | |
|-----------|-----|-------|-----|--------|---------|-------------------|
| 9 Pt..... | 10A | 1.15, | 28a | 1.55.. | 2 70... | <i>Corticifer</i> |
| 12..... | 10A | 1.45, | 25a | 1.85.. | 3 30... | <i>Corundum</i> |
| 18..... | 6A | 1.80, | 14a | 2.05.. | 3 85... | <i>Coruscant</i> |
| 24..... | 5A | 2.05, | 12a | 2.60.. | 4 65... | <i>Coruscates</i> |
| 30..... | 4A | 2.55, | 8a | 2.60.. | 5 15... | <i>Corvette</i> |
| 36..... | 3A | 2.90, | 6a | 2.90.. | 5 80... | <i>Corybantic</i> |

Culdee. C

| | | | | | | |
|-----------|-----|-------|-----|--------|---------|------------------|
| 6 Pt..... | 12A | 1.15, | 25a | 1.40.. | 2 55... | <i>Crakes</i> |
| 9..... | 10A | 1.40, | 20a | 1.40.. | 2 80... | <i>Crambo</i> |
| 12..... | 8A | 1.60, | 16a | 1.65.. | 3 25... | <i>Cramoisly</i> |
| 18..... | 5A | 1.90, | 10a | 1.90.. | 3 80... | <i>Crampbark</i> |
| 24..... | 4A | 2.30, | 8a | 2.30.. | 4 60... | <i>Crampbone</i> |

Cursive Script. A

| | | | | | | |
|------------|-----|-------|-----|--------|---------|----------------|
| 18 Pt..... | 10A | 2.75, | 40a | 3.25.. | 6 00... | <i>Crashed</i> |
|------------|-----|-------|-----|--------|---------|----------------|

Cushing. A

Craven

| | | | | | |
|-------|----------|---------|-------------|-----------|------------------|
| 6 Pt. | 12A, 20A | \$2.00, | 50a \$1.50, | \$3 50... | <i>Craveth</i> |
| 8 | 12A, 20A | 2.50, | 44a 1.50, | 4 00... | <i>Cravings</i> |
| 10 | 10A, 16A | 2.75, | 40a 1.75, | 4 50... | <i>Cravfish</i> |
| 12 | 8A, 14A | 3.25, | 36a 1.75, | 5 00... | <i>Crawled</i> |
| 15 | 15A | 1.80, | 25a 1.70, | 3 50... | <i>Crawling</i> |
| 18 | 12A | 2.30, | 18a 1.70, | 4 00... | <i>Crayoning</i> |
| 24 | 10A | 2.60, | 15a 1.90, | 4 50... | <i>Crayons</i> |

Cushing Fractions. A

| | | | |
|-------|-----------|---------|------------------|
| 6 Pt. | per font, | 1 00... | <i>Crazed</i> |
| 8 | | 1 00... | <i>Crazemill</i> |
| 10 | | 1 00... | <i>Crazily</i> |
| 12 | | 1 00... | <i>Craziness</i> |

Cushing Italic. A

Creaked

| | | | | | |
|-------|-----|-------|-----------|---------|-------------------|
| 6 Pt. | 28A | 1.16, | 80a 1.44, | 2 60... | <i>Creaking</i> |
| 8 | 28A | 1.45, | 80a 1.55, | 3 00... | <i>Creamcake</i> |
| 10 | 28A | 1.80, | 80a 2.00, | 3 80... | <i>Creamfaced</i> |
| 12 | 20A | 1.94, | 50a 2.00, | 3 94... | <i>Creamnut</i> |
| 15 | 15A | 1.85, | 25a 1.65, | 3 50... | <i>Creamy</i> |
| 18 | 10A | 2.10, | 20a 1.90, | 4 00... | <i>Creases</i> |
| 24 | 8A | 2.40, | 15a 2.10, | 4 50... | <i>Createth</i> |

CUSHING MONOTONE (sold at Roman prices).

Cushing Old Style. F

Credibly

| | | | | | |
|-------------|-----|-------|-----------|---------|-------------------|
| 6 Pt. No. 1 | 24A | 1.15, | 36a 1.10, | 2 25... | <i>Creditable</i> |
| 7 | 26A | 1.35, | 40a 1.15, | 2 50... | <i>Creditress</i> |
| 8 | 28A | 1.30, | 42a 1.20, | 2 50... | <i>Credulity</i> |
| 9 | 28A | 1.55, | 42a 1.20, | 2 75... | <i>Credulous</i> |
| 10 | 24A | 1.50, | 36a 1.25, | 2 75... | <i>Creepeth</i> |
| 11 | 22A | 1.55, | 34a 1.35, | 2 90... | <i>Creephole</i> |
| 12 | 20A | 1.60, | 30a 1.40, | 3 00... | <i>Creeping</i> |
| 14 | 16A | 1.75, | 24a 1.50, | 3 25... | <i>Creepingly</i> |
| 18 | 12A | 1.90, | 16a 1.60, | 3 50... | <i>Creeps</i> |
| 24 | 8A | 2.40, | 12a 2.10, | 4 50... | <i>Cremation</i> |
| 36 | 5A | 3.00, | 8a 2.50, | 5 50... | <i>Cremona</i> |
| 48 | 4A | 3.70, | 6a 3.30, | 7 00... | <i>Cremonese</i> |

Daisy Borders. E

Dashboard

| | | | |
|--------------|-----------|---------|--------------------|
| 12 Pt. No. 1 | per font, | 2 70... | <i>Dashing</i> |
| 6 | 2 | 1 50... | <i>Dashism</i> |
| 12 | 3 | 2 20... | <i>Dastardly</i> |
| 18 | 4 | 3 15... | <i>Dasyrometer</i> |

Darling Borders. E

Daughters

| | | | | |
|-------|--------|-----------|---------|------------------|
| 6 Pt. | 6 feet | per font, | 1 50... | <i>Daunted</i> |
| 12 | 6 " | | 1 75... | <i>Davntless</i> |

Delmonico Chefs and Waiters. F

| | | |
|----------|---------|----------------|
| Per font | 1 50... | <i>Dauphin</i> |
|----------|---------|----------------|

Devens Script. A

Daylabor

| | | | | | |
|-------|-----|-------|-----------|---------|----------------|
| 6 Pt. | 20A | 1.90, | 50a 1.60, | 3 50... | <i>Daymaid</i> |
| 8 | 18A | 2.00, | 44a 1.75, | 3 75... | <i>Daymare</i> |
| 10 | 16A | 2.00, | 40a 2.00, | 4 00... | <i>Dayrule</i> |
| 12 | 12A | 2.35, | 30a 1.90, | 4 25... | <i>Daysman</i> |
| 18 | 8A | 2.60, | 24a 2.50, | 4 50... | <i>Daytime</i> |

De Vinne. A-F

Deadpay

| | | | | | |
|--------|-----|--------|-----------|----------|-------------------|
| 5½ Pt. | 24A | 1.35, | 36a 1.15, | 2 50... | <i>Deadpile</i> |
| 6 | 24A | 1.25, | 36a 1.00, | 2 25... | <i>Deadplate</i> |
| 7 | 22A | 1.30, | 34a 1.20, | 2 50... | <i>Deadpoint</i> |
| 8 | 22A | 1.40, | 30a 1.10, | 2 50... | <i>Deadset</i> |
| 10 | 20A | 1.50, | 26a 1.25, | 2 75... | <i>Deadstruck</i> |
| 12 | 16A | 1.70, | 20a 1.30, | 3 00... | <i>Deadwater</i> |
| 14 | 12A | 1.75, | 18a 1.50, | 3 25... | <i>Deadweight</i> |
| 18 | 10A | 1.70, | 16a 1.55, | 3 25... | <i>Deadwood</i> |
| 24 | 8A | 2.30, | 10a 1.70, | 4 00... | <i>Deadworks</i> |
| 30 | 6A | 2.70, | 9a 2.30, | 5 00... | <i>Deafen</i> |
| 36 | 5A | 3.00, | 8a 2.50, | 5 50... | <i>Deafening</i> |
| 42 | 4A | 4.00, | 6a 3.25, | 7 25... | <i>Deafmute</i> |
| 48 | 4A | 4.65, | 5a 3.10, | 7 75... | <i>Deafness</i> |
| 54 | 4A | 6.00, | 5a 4.25, | 10 25... | <i>Dealbation</i> |
| 60 | 4A | 7.25, | 5a 5.00, | 12 25... | <i>Deambulate</i> |
| 72 | 4A | 10.00, | 5a 7.00, | 17 00... | <i>Deanery</i> |

De Vinne Condensed. F

Debarrass

| | | | | | |
|-------|-----|-------|-----------|---------|-------------------|
| 6 Pt. | 30A | 1.25, | 42a 1.00, | 2 25... | <i>Debarreth</i> |
| 8 | 25A | 1.40, | 36a 1.10, | 2 50... | <i>Debased</i> |
| 10 | 22A | 1.40, | 30a 1.35, | 2 75... | <i>Debasingly</i> |
| 12 | 18A | 1.60, | 22a 1.40, | 3 00... | <i>Debatable</i> |
| 14 | 12A | 1.75, | 20a 1.50, | 3 25... | <i>Debateful</i> |
| 18 | 10A | 1.60, | 16a 1.65, | 3 25... | <i>Debaters</i> |
| 24 | 8A | 2.10, | 12a 1.90, | 4 00... | <i>Debating</i> |
| 30 | 6A | 2.50, | 9a 2.00, | 4 50... | <i>Debauched</i> |
| 36 | 5A | 2.60, | 8a 2.40, | 5 00... | <i>Debauching</i> |

De Vinne Condensed—Continued.

| | | | | | |
|--------|----|---------|------------|-----------|-------------------|
| 42 Pt. | 4A | \$3.00, | 6a \$2.50, | \$5 50... | <i>Debellate</i> |
| 48 | 4A | 3.25, | 5a 2.75, | 6 00... | <i>Debenture</i> |
| 54 | 4A | 4.50, | 5a 3.00, | 7 50... | <i>Debilitate</i> |
| 60 | 4A | 6.00, | 5a 4.00, | 10 00... | <i>Debility</i> |
| 72 | 4A | 8.75, | 5a 6.25, | 15 00... | <i>Debonair</i> |

De Vinne Cond. Fractions. F

Decagram

| | | | |
|-------|-----------|-------|-------------------|
| 6 Pt. | per font, | 50... | <i>Decagram</i> |
| 8 | | 50... | <i>Decagymit</i> |
| 10 | | 50... | <i>Decahedron</i> |
| 12 | | 50... | <i>Decalcify</i> |
| 14 | | 50... | <i>Decaliter</i> |
| 18 | | 50... | <i>Decalogist</i> |
| 24 | | 75... | <i>Decalogue</i> |
| 30 | | 75... | <i>Decameron</i> |

De Vinne Extended. F

Decamp

| | | | | | |
|-------|-----|--------|-----------|----------|-------------------|
| 6 Pt. | 24A | 1.30, | 36a 1.20, | 2 50... | <i>Decamped</i> |
| 8 | 22A | 1.50, | 30a 1.25, | 2 75... | <i>Decamping</i> |
| 10 | 18A | 1.65, | 24a 1.35, | 3 00... | <i>Decandria</i> |
| 12 | 14A | 2.00, | 18a 1.50, | 3 50... | <i>Decandrous</i> |
| 14 | 10A | 2.00, | 14a 1.75, | 3 75... | <i>Decangular</i> |
| 18 | 9A | 2.50, | 12a 2.00, | 4 50... | <i>Decanters</i> |
| 24 | 6A | 3.00, | 10a 3.00, | 6 00... | <i>Decapitate</i> |
| 30 | 5A | 4.00, | 8a 3.00, | 7 00... | <i>Decapod</i> |
| 36 | 4A | 4.50, | 6a 3.50, | 8 00... | <i>Decapodal</i> |
| 42 | 4A | 5.75, | 5a 4.25, | 10 00... | <i>Decapodous</i> |
| 48 | 3A | 7.00, | 4a 4.50, | 11 50... | <i>Decastich</i> |
| 54 | 3A | 7.50, | 4a 5.50, | 13 00... | <i>Decastyle</i> |
| 60 | 3A | 9.75, | 4a 6.25, | 16 00... | <i>Decayed</i> |
| 72 | 3A | 13.00, | 4a 8.00, | 21 00... | <i>Decaying</i> |

De Vinne Extra Cond. F

Deciduons

| | | | | | |
|--------|-----|-------|-----------|----------|-------------------|
| 12 Pt. | 20A | 1.60, | 26a 1.40, | 3 00... | <i>Decimal</i> |
| 14 | 18A | 1.60, | 22a 1.65, | 3 25... | <i>Decimalism</i> |
| 18 | 12A | 1.55, | 20a 1.70, | 3 25... | <i>Decimally</i> |
| 24 | 10A | 2.00, | 16a 2.00, | 4 00... | <i>Decimated</i> |
| 30 | 8A | 2.50, | 12a 2.50, | 5 00... | <i>Decimating</i> |
| 36 | 6A | 2.05, | 12a 3.45, | 5 50... | <i>Decimators</i> |
| 42 | 6A | 3.00, | 10a 3.00, | 6 00... | <i>Decipher</i> |
| 48 | 5A | 3.50, | 8a 3.50, | 7 00... | <i>Decisive</i> |
| 54 | 5A | 4.25, | 7a 3.75, | 8 00... | <i>Decisory</i> |
| 60 | 4A | 5.25, | 5a 3.75, | 9 00... | <i>Decked</i> |
| 72 | 4A | 8.75, | 5a 6.25, | 15 00... | <i>Decking</i> |

De Vinne Fractions. F

| | | | |
|-------|-----------|-------|-------------------|
| 6 Pt. | per font, | 50... | <i>Declineth</i> |
| 7 | | 50... | <i>Declivity</i> |
| 8 | | 50... | <i>Declivous</i> |
| 10 | | 50... | <i>Decoet</i> |
| 12 | | 50... | <i>Decoeted</i> |
| 14 | | 50... | <i>Decoetible</i> |
| 18 | | 50... | <i>Decoction</i> |
| 24 | | 50... | <i>Decoctions</i> |

De Vinne Italic. F

Decorated

| | | | | | |
|-------|-----|--------|-----------|----------|-------------------|
| 6 Pt. | 24A | 1.25, | 36a 1.00, | 2 25... | <i>Decorating</i> |
| 8 | 22A | 1.40, | 30a 1.10, | 2 50... | <i>Decorators</i> |
| 10 | 20A | 1.45, | 26a 1.30, | 2 75... | <i>Decorous</i> |
| 12 | 16A | 1.60, | 20a 1.40, | 3 00... | <i>Decorously</i> |
| 14 | 12A | 1.75, | 18a 1.50, | 3 25... | <i>Decoybird</i> |
| 18 | 10A | 2.10, | 16a 1.90, | 4 00... | <i>Decoyduck</i> |
| 24 | 8A | 2.50, | 10a 2.00, | 4 50... | <i>Decoyman</i> |
| 30 | 6A | 3.00, | 9a 2.75, | 5 75... | <i>Decoys</i> |
| 36 | 5A | 3.50, | 8a 3.00, | 6 50... | <i>Decree</i> |
| 42 | 4A | 4.00, | 6a 3.25, | 7 25... | <i>Decrepit</i> |
| 48 | 4A | 4.50, | 5a 3.25, | 7 75... | <i>Decrescent</i> |
| 54 | 4A | 6.60, | 5a 4.65, | 11 25... | <i>Decretists</i> |
| 60 | 4A | 7.85, | 5a 5.40, | 13 25... | <i>Decretive</i> |
| 72 | 4A | 11.20, | 5a 7.80, | 19 00... | <i>Decrews</i> |

De Vinne Italic Outline. F

Deepdrawn

| | | | | | |
|--------|-----|--------|-----------|----------|-------------------|
| 12 Pt. | 16A | 1.60, | 20a 1.40, | 3 00... | <i>Deepen</i> |
| 14 | 12A | 1.75, | 18a 1.50, | 3 25... | <i>Deepening</i> |
| 18 | 10A | 2.10, | 16a 1.90, | 4 00... | <i>Deepest</i> |
| 24 | 8A | 2.50, | 10a 2.00, | 4 50... | <i>Deepplaid</i> |
| 30 | 6A | 3.00, | 9a 2.75, | 5 75... | <i>Deeply</i> |
| 36 | 5A | 3.50, | 8a 3.00, | 6 50... | <i>Deepness</i> |
| 42 | 4A | 4.00, | 6a 3.25, | 7 25... | <i>Deerhound</i> |
| 48 | 4A | 4.50, | 5a 3.25, | 7 75... | <i>Deerneck</i> |
| 54 | 4A | 6.00, | 5a 4.25, | 10 25... | <i>Deerskin</i> |
| 60 | 4A | 7.25, | 5a 5.00, | 12 25... | <i>Defaced</i> |
| 72 | 4A | 10.00, | 5a 7.00, | 17 00... | <i>Defacement</i> |

| | | | | | |
|-------------------------|-------------|-------------|-----------|-------------------|--|
| De Vinne Shaded. | | A | | Deferment | |
| 12 Pt..... | 16A \$1.85, | 20a \$1.40, | \$3 25... | <i>Deferred</i> | |
| 18..... | 10A 2.00, | 16a 1.75.. | 3 75... | <i>Deferring</i> | |
| 24..... | 8A 2.50, | 10a 2.00.. | 4 50... | <i>Defiant</i> | |
| 36..... | 5A 3.15, | 8a 2.60.. | 5 75... | <i>Defiatory</i> | |
| 42..... | 4A 4.15, | 6a 3.35.. | 7 50... | <i>Deficient</i> | |
| 48..... | 4A 4.65, | 5a 3.10.. | 7 75... | <i>Deficits</i> | |
| 54..... | 4A 6.00, | 5a 4.50.. | 10 50... | <i>Defilade</i> | |
| 60..... | 4A 7.25, | 5a 5.25.. | 12 50... | <i>Defilement</i> | |
| 72..... | 4A 10.00, | 5a 7.00.. | 17 00... | <i>Defileth</i> | |

DEWEY ORNAMENTS (see Ornaments).

| | | | | |
|---|--|----------|-------|-----------------|
| Diagonal Fraction Marks. | | D | | |
| Price per font, containing all three sizes..... | | | 75... | <i>Defiling</i> |

| | | | | |
|--------------------|--|----------|---------|----------------|
| Domestics. | | F | | |
| Per card font..... | | | 1 50... | <i>Defraud</i> |

| | | | | |
|-------------------------|-------------|----------|--|--------------------|
| Doric Fractions. | | E | | |
| 24 Pt..... | 1 lb. font, | 56... | | <i>Demolish</i> |
| 30..... | 1..... | 56... | | <i>Demolishing</i> |
| 36..... | 1..... | 56... | | <i>Demolition</i> |
| 42..... | 1..... | 54... | | <i>Demonetize</i> |

| | | | | | |
|-----------------------|-----------|------------|---------|-------------------|--|
| Doric No. 120. | | E | | Denticle | |
| 5 Pt. on 6 Pt..... | 24A 1.10, | 48a 1.45.. | 2 55... | <i>Dentiform</i> | |
| 6..... | 24A 1.20, | 48a 1.35.. | 2 55... | <i>Dentifrice</i> | |
| 7..... | 24A 1.25, | 48a 1.50.. | 2 75... | <i>Dentilave</i> | |
| 8..... | 20A 1.45, | 40a 1.65.. | 3 10... | <i>Dentiloquy</i> | |
| 10..... | 16A 1.40, | 32a 1.55.. | 2 95... | <i>Dentiscalp</i> | |
| 12..... | 12A 1.40, | 24a 1.50.. | 2 90... | <i>Dentist</i> | |
| 18..... | 10A 2.30, | 20a 2.90.. | 5 20... | <i>Dentistry</i> | |
| 24..... | 8A 2.40, | 16a 3.10.. | 5 50... | <i>Dentizing</i> | |
| 30..... | 4A 2.65, | 8a 2.75.. | 5 40... | <i>Denudate</i> | |
| 36..... | 4A 3.10, | 8a 3.30.. | 6 40... | <i>Denuded</i> | |
| 42..... | 3A 3.45, | 6a 3.45.. | 6 90... | <i>Denunciate</i> | |
| 48..... | 3A 4.40, | 6a 4.60.. | 9 00... | <i>Deodand</i> | |

| | | | | | |
|----------------------|-----------|------------|----------|-------------------|--|
| Doric Italic. | | A | | Deperdit | |
| 6 Pt..... | 18A 1.80, | 40a 1.70.. | 3 50... | <i>Dephlegm</i> | |
| 8..... | 15A 2.00, | 30a 1.75.. | 3 75... | <i>Depicted</i> | |
| 10..... | 12A 2.10, | 25a 1.90.. | 4 00... | <i>Depitates</i> | |
| 12..... | 10A 2.25, | 20a 2.00.. | 4 25... | <i>Depitating</i> | |
| 18..... | 8A 2.50, | 12a 2.00.. | 4 50... | <i>Depilatory</i> | |
| 24..... | 6A 2.65, | 10a 2.35.. | 5 00... | <i>Depleted</i> | |
| 30..... | 5A 3.70, | 7a 2.80.. | 6 50... | <i>Depletion</i> | |
| 36..... | 5A 5.00, | 7a 3.75.. | 8 75... | <i>Deplorably</i> | |
| 48..... | 4A 6.60, | 5a 4.15.. | 10 75... | <i>Deplores</i> | |
| 60..... | 4A 9.50, | 5a 6.00.. | 15 50... | <i>Deploring</i> | |

DOTLET ORNAMENTS (see Ornaments).

| | | | | | |
|-----------------|-----------|------------|---------|-------------------|--|
| Douglas. | | E | | Depulsion | |
| 10 Pt..... | 18A 1.15, | 36a 1.25.. | 2 40... | <i>Depurator</i> | |
| 12..... | 12A 1.00, | 24a 1.10.. | 2 10... | <i>Deputation</i> | |
| 18..... | 10A 1.65, | 20a 1.65.. | 3 30... | <i>Deputing</i> | |
| 24..... | 8A 2.05, | 16a 2.25.. | 4 30... | <i>Deputized</i> | |
| 30..... | 6A 2.20, | 12a 2.25.. | 4 45... | <i>Deputy</i> | |
| 36..... | 4A 2.45, | 8a 2.45.. | 4 90... | <i>Deracinate</i> | |
| 42..... | 3A 2.60, | 6a 2.40.. | 5 00... | <i>Deranged</i> | |
| 48..... | 3A 3.25, | 6a 3.00.. | 6 25... | <i>Deranging</i> | |

| | | | | | |
|-----------------|-----------|------------|---------|-------------------|--|
| Dresden. | | A | | Despondent | |
| 18 Pt..... | 12A 1.65, | 18a 1.60.. | 3 25... | <i>Desponding</i> | |
| 24..... | 8A 2.15, | 12a 1.85.. | 4 00... | <i>Desponsory</i> | |
| 36..... | 6A 2.35, | 9a 2.15.. | 4 50... | <i>Despotic</i> | |
| 48..... | 4A 3.00, | 7a 2.50.. | 5 50... | <i>Despotical</i> | |

| | | | | |
|-------------------|--|----------|---------|------------------|
| Druggists. | | F | | |
| Per font..... | | | 1 50... | <i>Despotism</i> |

| | | | | | |
|----------------|-----------|------------|----------|------------------|--|
| Duerer. | | A | | Devilkin | |
| 12 Pt..... | 18A 1.60, | 24a 1.40.. | 3 00... | <i>Devilship</i> | |
| 18..... | 11A 1.55, | 16a 1.70.. | 3 25... | <i>Deviltry</i> | |
| 24..... | 8A 2.20, | 11a 1.80.. | 4 00... | <i>Devilwood</i> | |
| 36..... | 5A 2.55, | 7a 2.20.. | 4 75... | <i>Devious</i> | |
| 48..... | 3A 3.50, | 4a 2.50.. | 6 00... | <i>Deviousty</i> | |
| 60..... | 3A 4.75, | 6a 4.25.. | 9 00... | <i>Deviseth</i> | |
| 72..... | 3A 5.75, | 5a 4.25.. | 10 00... | <i>Devising</i> | |

| | | | | | |
|----------------|-----------|------------|---------|-------------------|--|
| Dynamo. | | C | | Diametric | |
| 12 Pt..... | 16A 1.10, | 25a 1.15.. | 2 25... | <i>Diamond</i> | |
| 18..... | 10A 1.30, | 14a 1.15.. | 2 45... | <i>Diamondize</i> | |
| 24..... | 8A 1.65, | 10a 1.35.. | 3 00... | <i>Dianbria</i> | |
| 36..... | 4A 1.80, | 6a 1.80.. | 3 60... | <i>Diandrous</i> | |
| 48..... | 3A 2.70, | 4a 1.85.. | 4 55... | <i>Diapason</i> | |

| | | | | |
|--------------------------|-------------|--------------|-----------|----------------|
| Earle Typewriter. | | F | | |
| 12 Pt..... | 20A \$3.40, | 108a \$4.10, | \$7 50... | <i>Earnest</i> |

| | | | | | |
|-----------------|-----------|------------|----------|-------------------|--|
| Eastman. | | F | | Eavesboard | |
| 6 Pt..... | 24A 1.20, | 48a 1.10.. | 2 30... | <i>Eavescatch</i> | |
| 8..... | 22A 1.30, | 30a 1.20.. | 2 50... | <i>Eavesdrop</i> | |
| 9..... | 20A 1.30, | 40a 1.25.. | 2 55... | <i>Eaveslaths</i> | |
| 10..... | 20A 1.40, | 26a 1.35.. | 2 75... | <i>Ebbing</i> | |
| 12..... | 16A 1.70, | 20a 1.30.. | 3 00... | <i>Ebblide</i> | |
| 18..... | 10A 1.75, | 16a 1.50.. | 3 25... | <i>Ebbanine</i> | |
| 24..... | 8A 2.10, | 10a 1.90.. | 4 00... | <i>Ebonized</i> | |
| 30..... | 6A 2.60, | 9a 2.40.. | 5 00... | <i>Ebonizing</i> | |
| 36..... | 5A 2.90, | 8a 2.60.. | 5 50... | <i>Ebonytree</i> | |
| 48..... | 4A 3.65, | 6a 3.30.. | 6 95... | <i>Ebracteate</i> | |
| 60..... | 4A 6.00, | 5a 3.90.. | 9 90... | <i>Ebriety</i> | |
| 72..... | 3A 6.65, | 5a 4.00.. | 10 65... | <i>Ebrious</i> | |

| | | | | | |
|-------------------|----------|----------|--|-----------------|-------------------|
| Eccentric. | | F | | Ecumenic | |
| 18 Pt..... | 10A..... | | | 1 90... | <i>Ecumenical</i> |
| 24..... | 8A..... | | | 2 35... | <i>Edacious</i> |
| 36..... | 6A..... | | | 3 50... | <i>Edacity</i> |

| | | | | | |
|-------------------------|----------|----------|--|---------------|-------------------|
| Edinburgh Title. | | F | | Ediles | |
| 9 Pt..... | 22A..... | | | 1 50... | <i>Edileship</i> |
| 10..... | 20A..... | | | 1 50... | <i>Edition</i> |
| 12..... | 16A..... | | | 1 50... | <i>Editorial</i> |
| 14..... | 18A..... | | | 2 00... | <i>Editors</i> |
| 16..... | 18A..... | | | 2 00... | <i>Editorship</i> |
| 20..... | 12A..... | | | 2 50... | <i>Editress</i> |
| 24..... | 10A..... | | | 3 00... | <i>Educable</i> |
| 36..... | 7A..... | | | 4 65... | <i>Education</i> |

| | | | | | | | |
|---------------------------------|-----------|-----------------|---------|-------------------|--|----------------|--|
| Egyptian Extra Condensed | | No. 120. | | E | | Elusive | |
| 12 Pt..... | 16A 1.15, | 32a 1.45.. | 2 60... | <i>Elvish</i> | | | |
| 18..... | 12A 1.25, | 24a 1.55.. | 2 80... | <i>Elydoric</i> | | | |
| 24..... | 12A 1.90, | 24a 2.40.. | 4 30... | <i>Elytrine</i> | | | |
| 36..... | 8A 2.45, | 16a 2.80.. | 5 25... | <i>Emaciated</i> | | | |
| 42..... | 8A 3.20, | 16a 3.85.. | 7 05... | <i>Emaciation</i> | | | |
| 48..... | 4A 2.45, | 8a 2.75.. | 5 20... | <i>Emaculates</i> | | | |
| 60..... | 4A 3.50, | 8a 3.90.. | 7 40... | <i>Emanates</i> | | | |
| 72..... | 3A 4.20, | 6a 4.50.. | 8 70... | <i>Emanating</i> | | | |

EGYPTIAN ORNAMENTS (see Ornaments).

| | | | |
|--------------------------------|--------------|------------|--------------------|
| Eighteen Point Borders. | | C-D | |
| No. 1..... | 10 feet..... | 4 95... | <i>Embellished</i> |
| 1..... | 5..... | 2 75... | <i>Embellisher</i> |
| 2..... | 10..... | 4 95... | <i>Embergoose</i> |
| 2..... | 5..... | 2 75... | <i>Emberingday</i> |
| 4..... | 10..... | 4 95... | <i>Emberiza</i> |
| 4..... | 5..... | 2 75... | <i>Emberizine</i> |
| 5..... | 10..... | 4 95... | <i>Emberweek</i> |
| 5..... | 5..... | 2 75... | <i>Embetter</i> |
| 6..... | 10..... | 4 95... | <i>Embezzle</i> |
| 6..... | 5..... | 2 75... | <i>Embezzled</i> |
| 7..... | 10..... | 4 95... | <i>Embezzlers</i> |
| 7..... | 5..... | 2 75... | <i>Embezzling</i> |
| 27..... | 24 inches, | 1 00... | <i>Embia</i> |
| 1801..... | 72..... | 3 00... | <i>Embillow</i> |
| 1802..... | 72..... | 3 00... | <i>Embittered</i> |
| 1803..... | 72..... | 3 00... | <i>Emblazed</i> |
| 1804..... | 72..... | 3 00... | <i>Emblazing</i> |
| 1805..... | 72..... | 3 00... | <i>Emblazonry</i> |
| 1806..... | 72..... | 3 00... | <i>Emblematic</i> |

| | | | | | |
|-------------------|----------|----------|--|----------------|-------------------|
| Elandkay. | | A | | Embolus | |
| 6 Pt. No. 21..... | 40A..... | | | 1 25... | <i>Embonpoint</i> |
| 6..... | 22..... | 40A..... | | | 1 25... |
| 6..... | 23..... | 30A..... | | | 1 50... |
| 6..... | 24..... | 30A..... | | | 1 50... |
| 12..... | 25..... | 24A..... | | | 1 50... |
| 12..... | 26..... | 18A..... | | | 1 50... |
| 12..... | 27..... | 16A..... | | | 1 50... |
| 18..... | 28..... | 14A..... | | | 1 75... |
| 18..... | 29..... | 12A..... | | | 2 00... |
| 24..... | 8A..... | | | | 2 50... |
| 36..... | 6A..... | | | | 3 25... |

| | | | | | |
|-----------------------|-----------|------------|---------|-------------------|--|
| Elberon No. 2. | | E | | Embrowned | |
| 12 Pt..... | 10A 2.00, | 18a 1.90.. | 3 90... | <i>Embryo</i> | |
| 18..... | 8A 2.85, | 14a 2.40.. | 5 25... | <i>Embryogeny</i> | |
| 24..... | 6A 3.50, | 10a 3.20.. | 6 70... | <i>Embryology</i> | |
| 36..... | 4A 5.50, | 6a 3.80.. | 8 80... | <i>Embryonal</i> | |

Election Signs.

| No. | Body. | Each. | 50 or More, Each. | 100 or More, Each. |
|-----|--------|-------|-------------------|--------------------|
| 1 | 12 Pt. | \$.05 | \$.04 | \$.03 |
| 2 | 20 Pt. | .06 | .04 | .03 |
| 3 | 20 Pt. | .06 | .04 | .03 |
| 4 | 40 Pt. | .15 | .12 | .10 |
| 5 | 40 Pt. | .15 | .12 | .10 |
| 6 | 12 Pt. | .06 | .04 | .03 |
| 7 | 10 Pt. | .06 | .04 | .03 |
| 8 | 8 Pt. | .06 | .04 | .03 |
| 9 | 30 Pt. | .06 | .04 | .04 |
| 10 | 30 Pt. | .06 | .04 | .04 |
| 11 | 30 Pt. | .06 | .04 | .04 |
| 12 | 30 Pt. | .06 | .04 | .04 |
| 13 | 30 Pt. | .06 | .04 | .04 |
| 14 | 72 Pt. | .25 | — | — |
| 15 | 24 Pt. | .06 | .04 | .04 |
| 16 | 30 Pt. | .06 | .04 | .04 |
| 17 | 30 Pt. | .06 | .04 | .04 |
| 18 | 30 Pt. | .06 | .04 | .04 |
| 19 | 30 Pt. | .06 | .04 | .04 |
| 20 | 24 Pt. | .06 | .04 | .04 |

ELECTRIC ORNAMENTS (see Ornaments).

ELECTROTYPED INITIALS (see Initials).

ELECTROTYPED NEWSPAPER HEADINGS (see Newspaper Headings).

ELECTROTYPED TAKE SLUGS (see Take Slugs).

Elzevir Borders, Bands and Ornaments.

| 6 Pt. No. | 100 | 54 inches | \$1 50 | ... | Emptaster |
|-----------|-----|----------------|--------|-----|------------|
| 7 | 101 | 54 | 1 50 | ... | Emplastics |
| 14 | 102 | 36 | 1 50 | ... | Employ |
| 14 | 103 | 36 | 1 50 | ... | Employable |
| 14 | 104 | 36 | 1 50 | ... | Employers |
| 14 | 105 | 36 | 1 50 | ... | Employment |
| 14 | 106 | 36 | 1 50 | ... | Empoisoned |
| 14 | 107 | 36 | 1 50 | ... | Emporctic |
| 20 | 108 | 30 | 1 50 | ... | Emporium |
| 20 | 109 | 30 | 1 50 | ... | Empresses |
| 20 | 110 | 30 | 1 50 | ... | Emptier |
| 24 | 115 | 20 | 1 50 | ... | Emptified |
| 28 | 112 | 18 | 1 50 | ... | Empinness |
| 28 | 113 | 18 | 1 50 | ... | Emptying |
| 28 | 114 | 18 | 1 50 | ... | Empuzzled |
| 28 | 116 | 18 | 1 50 | ... | Eryngium |
| 28 | 117 | 18 | 1 50 | ... | Eryngo |
| 28 | 118 | 18 | 1 50 | ... | Erysimum |
| 28 | 119 | 18 | 1 50 | ... | Erysipelas |
| 28 | 120 | 18 | 1 50 | ... | Erythema |
| 28 | 121 | 18 | 1 50 | ... | Erythrine |
| 28 | 122 | 18 | 1 50 | ... | Erythrogen |
| 28 | 123 | 18 | 1 50 | ... | Erythryna |
| 36 | 111 | 18 | 1 50 | ... | Escalade |
| 42 | 124 | 12 | 1 50 | ... | Escalading |
| 42 | 125 | 12 | 1 50 | ... | Escalop |
| 48 | 126 | per character, | 15 | ... | |
| 48 | 127 | " | 15 | ... | |

Elzevir Florets.

| Group | A | per font, | 1 50 | ... | Escheat |
|-------|---|-----------|------|-----|------------|
| B | | | 1 50 | ... | Escheating |
| C | | | 2 00 | ... | Eschevin |
| D | | | 2 00 | ... | Eschew |

Elzevir Gothic.

| 6 Pt. | 25A | \$1.15, | 50a | \$1.35. | 2 50 | ... | Eschewance |
|-------|-----|---------|-----|---------|-------|-----|------------|
| 8 | 22A | 1.25, | 44a | 1.50. | 2 75 | ... | Eschewer |
| 10 | 20A | 1.35, | 40a | 1.65. | 3 00 | ... | Escheweth |
| 12 | 18A | 1.50, | 36a | 2.00. | 3 50 | ... | Eschewing |
| 14 | 15A | 1.75, | 30a | 2.25. | 4 00 | ... | Eschinite |
| 18 | 12A | 2.25, | 24a | 2.25. | 4 50 | ... | Esclavage |
| 24 | 8A | 2.50, | 16a | 2.50. | 5 00 | ... | Escopet |
| 30 | 6A | 2.65, | 12a | 2.85. | 5 50 | ... | Escorted |
| 36 | 5A | 3.00, | 9a | 3.00. | 6 00 | ... | Escorting |
| 48 | 3A | 4.00, | 6a | 4.00. | 8 00 | ... | Escritoire |
| 60 | 3A | 6.50, | 5a | 5.00. | 11 50 | ... | Escrow |

Elzevir Italic.

| 14 Pt. | 16A | 1.90, | 36a | 2.00. | 3 90 | ... | Esguard |
|--------|-----|-------|-----|-------|------|-----|---------|
|--------|-----|-------|-----|-------|------|-----|---------|

Empire Borders.

| 24 Pt. No. | 1 | per font, | 2 00 | ... | Esparto |
|------------|---|-----------|------|-----|------------|
| 24 | 2 | | 2 00 | ... | Especially |
| 24 | 3 | | 2 00 | ... | Esperance |
| 36 | 1 | | 2 50 | ... | Espial |
| 36 | 2 | | 2 50 | ... | Esptiers |
| 36 | 3 | | 2 50 | ... | Espionage |

Empire Initials.

| | | | | |
|--------|-----------|--------|-----|----------|
| 48 Pt. | per font, | \$3 00 | ... | Esplotte |
| 72 | | 4 00 | ... | Esplus |

EMPIRE ORNAMENTS (see Ornaments).

Epitaph.

| 12 Pt. | 14A | 2 25 | ... | Estridge |
|--------|-----|------|-----|-----------|
| 18 | 9A | 2 50 | ... | Estuance |
| 24 | 7A | 3 25 | ... | Estuary |
| 36 | 5A | 4 25 | ... | Estruates |
| 48 | 3A | 6 00 | ... | Estuation |
| | | | ... | Esurient |

Epitaph Open.

| 24 Pt. | 7A | 3 25 | ... | Estrine |
|--------|----|------|-----|---------|
| 36 | 5A | 4 25 | ... | Etagere |
| 48 | 3A | 6 00 | ... | Etchers |

Erebus.

| 24 Pt. | 8A | 2 25 | ... | Etheriform |
|--------|----|------|-----|------------|
| 36 | 6A | 3 50 | ... | Etherine |
| 48 | 5A | 4 50 | ... | Etherized |
| 60 | 4A | 5 75 | ... | Ethical |
| | | | ... | Ethically |

Erratick.

| 6 Pt. | 20A | \$1.25, | 40a | \$1.00. | 2 25 | ... | Ethnologic |
|-------|-----|---------|-----|---------|------|-----|-------------|
| 8 | 20A | 1.40, | 32a | 1.10. | 2 50 | ... | Ethopoeitic |
| 10 | 16A | 1.50, | 32a | 1.25. | 2 75 | ... | Ethyle |
| 12 | 14A | 1.50, | 24a | 1.50. | 3 00 | ... | Ethyls |
| 18 | 10A | 2.00, | 18a | 1.50. | 3 50 | ... | Etiolate |
| 24 | 8A | 2.50, | 12a | 1.50. | 4 00 | ... | Etiolating |
| 30 | 6A | 3.00, | 8a | 2.50. | 5 50 | ... | Etiolation |
| 42 | 4A | 3.50, | 6a | 2.50. | 6 00 | ... | Etiology |
| 48 | 4A | 5.00, | 5a | 2.50. | 7 50 | ... | Etiquette |
| | | | | | | ... | Etrurians |

Erratick Outline.

| 6 Pt. | 20A | 1.25, | 40a | 1.00. | 2 25 | ... | Etudes |
|-------|-----|-------|-----|-------|------|-----|------------|
| 8 | 20A | 1.40, | 32a | 1.10. | 2 50 | ... | Etymology |
| 10 | 16A | 1.50, | 32a | 1.25. | 2 75 | ... | Etymon |
| 12 | 14A | 1.50, | 24a | 1.50. | 3 00 | ... | Eucalyrite |
| 18 | 10A | 2.00, | 18a | 1.50. | 3 50 | ... | Eucalyptus |
| 24 | 8A | 2.50, | 12a | 1.50. | 4 00 | ... | Eucharist |
| 30 | 6A | 3.00, | 8a | 2.50. | 5 50 | ... | Euchlore |
| 42 | 4A | 3.50, | 6a | 2.50. | 6 00 | ... | Euchloric |
| 48 | 4A | 5.00, | 5a | 2.50. | 7 50 | ... | Euchology |
| | | | | | | ... | Euchre |

Ext'd Clarendon No. 30.

| 5 Pt. | 30A | 2 25 | ... | Eusebian |
|-------|--------|------|------|------------|
| 6 | 30A | 2 25 | ... | Eustachian |
| 8 | 30A | 2 50 | ... | Euterpe |
| 10 | 20A | 2 00 | ... | Euterpean |
| 10 | No. 32 | 20A | 2 00 | Euthanasia |
| 12 | 20A | 3 15 | ... | Eutrophy |
| 16 | 15A | 3 40 | ... | Eutychian |
| 20 | 10A | 3 70 | ... | Euxanthine |
| 24 | 6A | 3 45 | ... | Euxenite |
| 30 | 5A | 3 65 | ... | Evacuated |

Extra Condensed No. 43.

| 6 Pt. | 52A | 2 00 | ... | Excilingly |
|-------|-----|-------|-----|--------------|
| 8 | 52A | 2 70 | ... | Exclaim |
| 12 | 36A | 2 60 | ... | Exclaimers |
| 20 | 25A | 3 40 | ... | Exclaimeth |
| 24 | 22A | 4 50 | ... | Exclaiming |
| 36 | 14A | 3 80 | ... | Exclude |
| 42 | 14A | 4 80 | ... | Excludeth |
| 48 | 10A | 6 30 | ... | Exclusion |
| 60 | 10A | 8 20 | ... | Exclusory |
| 72 | 7A | 8 40 | ... | Excocot |
| 96 | 7A | 12 60 | ... | Excocotion |
| | | | ... | Excogitation |

Extra Condensed No. 123.

| *8 Pt. | 40A | 2.00, | 50a | 1.50. | 3 50 | ... | Executor |
|--------|-----|-------|-----|-------|------|-----|-----------|
| *10 | 30A | 1.80, | 40a | 1.30. | 3 10 | ... | Exceptant |
| 12 | 16A | 1.20, | 32a | 1.45. | 2 65 | ... | Excepting |
| 14 | 12A | 1.20, | 24a | 1.35. | 2 55 | ... | Executrix |
| 18 | 12A | 1.35, | 24a | 1.65. | 3 00 | ... | Exedra |
| 20 | 10A | 1.45, | 20a | 1.65. | 3 10 | ... | Exegesis |
| 24 | 8A | 1.70, | 16a | 1.95. | 3 65 | ... | Exegete |
| 36 | 6A | 2.20, | 12a | 2.50. | 4 70 | ... | Exegetics |
| 42 | 5A | 2.20, | 10a | 2.60. | 4 80 | ... | Exemplar |
| 48 | 4A | 2.85, | 8a | 2.95. | 5 80 | ... | Exemplify |
| | | | | | | ... | Exempt |

Extra Condensed No. 234.

| 72 Pt. | 5A | 5.60, | 10a | 4.90. | 10 50 | ... | Exhibiteth |
|--------|----|-------|-----|-------|-------|-----|------------|
| 96 | 4A | 6.05, | 8a | 4.95. | 11 00 | ... | Exhibiting |
| 120 | 3A | 7.05, | 6a | 5.45. | 12 50 | ... | Exhibition |
| | | | | | | ... | Exhibitors |

| | | | |
|------------------|----------|-------------------|---------------------|
| Facade. A | | <i>Fustidious</i> | |
| 6 Pt..... | 36A..... | \$1 50... | <i>Fastigate</i> |
| 8..... | 36A..... | 1 75... | <i>Fastigium</i> |
| 10..... | 30A..... | 2 00... | <i>Fastingday</i> |
| 12..... | 25A..... | 2 25... | <i>Fatnesses</i> |
| 18..... | 18A..... | 2 75... | <i>Fatalism</i> |
| 20..... | 16A..... | 3 00... | <i>Fataticistic</i> |
| 24..... | 12A..... | 3 25... | <i>Fatally</i> |
| 30..... | 9A..... | 3 50... | <i>Fatabness</i> |
| 36..... | 8A..... | 4 00... | <i>Fatbrained</i> |
| 42..... | 6A..... | 4 25... | <i>Fatheaded</i> |
| 48..... | 5A..... | 4 75... | <i>Fatherhood</i> |
| 54..... | 5A..... | 5 50... | <i>Fatherlike</i> |
| 60..... | 5A..... | 6 50... | <i>Fatherly</i> |

| | | | |
|----------------------------|----------|---------------|-------------------|
| Facade Condensed. A | | <i>Fathom</i> | |
| 10 Pt..... | 46A..... | 2 00... | <i>Fathomable</i> |
| 12..... | 40A..... | 2 25... | <i>Fathomless</i> |
| 16..... | 30A..... | 2 50... | <i>Fatidical</i> |
| 18..... | 28A..... | 2 75... | <i>Fatiferous</i> |
| 24..... | 20A..... | 3 00... | <i>Fatigable</i> |
| 30..... | 16A..... | 3 50... | <i>Fatigated</i> |
| 36..... | 16A..... | 4 00... | <i>Fatigue</i> |
| 42..... | 14A..... | 4 50... | <i>Fatiguing</i> |
| 48..... | 12A..... | 5 25... | <i>Fatimite</i> |
| 54..... | 12A..... | 6 00... | <i>Fatiscence</i> |
| 60..... | 12A..... | 6 75... | <i>Fatlings</i> |
| 72..... | 9A..... | 7 25... | <i>Fatlute</i> |

| | | | |
|--------------------------------|-------------------------|-----------------|------------------|
| Facade Condensed No. 2. | | <i>Fattness</i> | |
| 10 Pt..... | 46A \$2.00, 50a \$1.25. | 3 25... | <i>Fattish</i> |
| 12..... | 40A 2.25, 44a 1.50. | 3 75... | <i>Fatuity</i> |
| 16..... | 30A 2.50, 34a 1.50. | 4 00... | <i>Fatuous</i> |
| 18..... | 28A 2.75, 32a 2.00. | 4 75... | <i>Fatwitted</i> |
| 24..... | 20A 3.00, 24a 2.00. | 5 00... | <i>Faubourg</i> |
| 30..... | 16A 3.50, 20a 2.50. | 6 00... | <i>Faucal</i> |
| 36..... | 16A 4.00, 20a 3.00. | 7 00... | <i>Faucets</i> |
| 42..... | 14A 4.50, 18a 3.75. | 8 25... | <i>Faufel</i> |
| 48..... | 12A 5.25, 16a 3.75. | 9 00... | <i>Faultful</i> |
| 54..... | 12A 6.00, 16a 4.75. | 10 75... | <i>Faultily</i> |
| 60..... | 12A 6.75, 16a 5.75. | 12 50... | <i>Faultless</i> |
| 72..... | 9A 7.25, 12a 6.25. | 13 50... | <i>Faunist</i> |

FIFTH INITIALS (see Initials).

FINE-DOT LEADERS (see Leaders).

| | | | |
|--------------------------------|-----------------------|-----------------|--|
| Five-Pointed Stars. B-F | | <i>Fauteuil</i> | |
| 201F to 215F..... | font of four each, | 1 00... | |
| 201F to 210F..... | eight of any size, | 25... | |
| 211F and 212F..... | eight of either size, | 35... | |
| 213F to 215F..... | eight of any size, | 50... | |
| 216F and 217F..... | each, | 15... | |
| 218F and 219F..... | each, | 20... | |
| 220F..... | | 25... | |
| 230F to 232F..... | eight of any size, | 35... | |
| 233F to 235F..... | four of any size, | 40... | |
| 236F and 316B..... | four of either size, | 60... | |
| 317B..... | | 20... | |
| 318B to 320B..... | each, | 10... | |
| 321B..... | | 15... | |
| 322B..... | | 20... | |
| 323B..... | | 25... | |

| | | | |
|------------------------|------------|------------------|-------------------|
| Flag Borders. H | | <i>Favillous</i> | |
| FOR ONE COLOR: | | | |
| 12 Pt. No. 1..... | 72 inches, | 3 50... | |
| 18..... | 60..... | 3 35... | <i>Favorably</i> |
| 24..... | 60..... | 4 40... | <i>Favorers</i> |
| 36..... | 18..... | 2 25... | <i>Favoring</i> |
| FOR TWO COLORS: | | | |
| 12 Pt. No. 2..... | 36 inches, | 3 50... | <i>Favorite</i> |
| 18..... | 30..... | 3 35... | <i>Favoritism</i> |
| 24..... | 30..... | 4 40... | <i>Fawkner</i> |
| 36..... | 18..... | 4 50... | <i>Fawningly</i> |

| | | | |
|-------------------------|------------|-----------------|-----------------|
| Flame Borders. H | | <i>Fayalite</i> | |
| 6 Pt..... | 42 inches, | 1 75... | <i>Fayence</i> |
| 12..... | 36..... | 1 75... | <i>Fazzolet</i> |
| 18..... | 36..... | 2 00... | <i>Fearly</i> |
| 24..... | 36..... | 2 65... | <i>Fearth</i> |
| 36..... | 50..... | 4 50... | <i>Fearful</i> |

| | | | |
|-------------------------|-----------|------------------|-----------------|
| Floral Border. c | | <i>Fearfully</i> | |
| No. 1..... | per font, | 1 50... | <i>Fearless</i> |
| 2..... | | 2 50... | <i>Feasibly</i> |

| | | | |
|------------------------------|------------|--------------|-------------------|
| Florentine Borders. A | | <i>Finis</i> | |
| 6 Pt. No. 165..... | 54 inches, | \$1 50... | <i>Filecutter</i> |
| 6..... | 54..... | 1 50... | <i>Filemot</i> |
| 6..... | 54..... | 1 50... | <i>Filibuster</i> |
| 6..... | 54..... | 1 50... | <i>Filical</i> |
| 6..... | 54..... | 1 50... | <i>Filiciform</i> |
| 6..... | 54..... | 1 50... | <i>Filicite</i> |
| 8..... | 50..... | 1 50... | <i>Filicoid</i> |
| 8..... | 50..... | 1 50... | <i>Filigraane</i> |
| 8..... | 50..... | 1 50... | <i>Filigreed</i> |
| 8..... | 50..... | 1 50... | <i>Filings</i> |
| 8..... | 50..... | 1 50... | <i>Filleted</i> |
| 8..... | 50..... | 1 50... | <i>Filleting</i> |
| 8..... | 50..... | 1 50... | <i>Fillibeg</i> |
| 8..... | 50..... | 1 50... | <i>Filling</i> |
| 8..... | 50..... | 1 50... | <i>Fillingly</i> |
| 8..... | 50..... | 1 50... | <i>Fillip</i> |
| 10..... | 40..... | 1 50... | <i>Fillicated</i> |
| 12..... | 36..... | 1 50... | <i>Filipping</i> |
| 12..... | 36..... | 1 50... | <i>Filminess</i> |
| 12..... | 36..... | 1 50... | <i>Filly</i> |
| 12..... | 36..... | 1 50... | <i>Filtrated</i> |
| 12..... | 36..... | 1 50... | <i>Filtration</i> |
| 12..... | 36..... | 1 50... | <i>Fimblehemp</i> |
| 12..... | 36..... | 1 50... | <i>Fimbria</i> |
| 12..... | 36..... | 1 50... | <i>Fimbriated</i> |
| 12..... | 36..... | 1 50... | <i>Fimbricate</i> |
| 14..... | 30..... | 1 50... | <i>Finale</i> |
| 16..... | 30..... | 1 50... | <i>Finally</i> |
| 16..... | 30..... | 1 50... | <i>Finance</i> |
| 16..... | 30..... | 1 50... | <i>Financial</i> |
| 18..... | 30..... | 1 50... | <i>Financiers</i> |
| 18..... | 30..... | 1 50... | <i>Finative</i> |
| 18..... | 30..... | 1 50... | <i>Finback</i> |
| 18..... | 30..... | 1 50... | <i>Finches</i> |
| 18..... | 30..... | 1 50... | <i>Findings</i> |
| 18..... | 30..... | 1 50... | <i>Findjan</i> |
| 18..... | 30..... | 1 50... | <i>Fine</i> |
| 18..... | 30..... | 1 50... | <i>Finearch</i> |
| 18..... | 30..... | 1 50... | <i>Finearched</i> |
| 18..... | 30..... | 1 50... | <i>Finet</i> |
| 24..... | 20..... | 1 50... | <i>Finedrawn</i> |
| 24..... | 20..... | 1 50... | <i>Finely</i> |
| 24..... | 20..... | 1 50... | <i>Fineries</i> |
| 24..... | 20..... | 1 50... | <i>Finespun</i> |
| 24..... | 20..... | 1 50... | <i>Finesse</i> |
| 24..... | 20..... | 1 50... | <i>Finessing</i> |

| | | | |
|---------------------------------|-------------------------|--------------|-------------------|
| Florentine Heavy Face. A | | <i>Finis</i> | |
| 5 Pt. on 6 Pt..... | 24A \$1.25, 36a \$1.25. | 2 50... | <i>Finish</i> |
| 6..... | 24A 1.40, 36a 1.10. | 2 50... | <i>Finished</i> |
| 8..... | 22A 1.50, 30a 1.25. | 2 75... | <i>Finisher</i> |
| 10..... | 20A 1.65, 26a 1.35. | 3 00... | <i>Finishing</i> |
| 12..... | 16A 1.85, 20a 1.40. | 3 25... | <i>Finite</i> |
| 18..... | 10A 2.10, 16a 1.90. | 4 00... | <i>Finiteless</i> |
| 24..... | 8A 2.55, 10a 1.95. | 4 50... | <i>Finity</i> |
| 36..... | 5A 2.85, 8a 2.65. | 5 50... | <i>Finitor</i> |
| 48..... | 4A 4.25, 5a 3.50. | 7 75... | <i>Finitude</i> |

| | | | |
|--------------------------------------|---------------------|----------------|-------------------|
| Florentine Old Style No. 2. A | | <i>Finless</i> | |
| 6 Pt..... | 36A 1.50, 40a 1.00. | 2 50... | <i>Finlet</i> |
| 8..... | 30A 1.75, 32a 1.00. | 2 75... | <i>Finnikin</i> |
| 10..... | 25A 2.00, 32a 1.25. | 3 25... | <i>Finochio</i> |
| 12..... | 20A 2.25, 24a 1.50. | 3 75... | <i>Finscate</i> |
| 18..... | 15A 2.75, 14a 1.75. | 4 50... | <i>Fintoed</i> |
| 24..... | 10A 3.00, 10a 2.00. | 5 00... | <i>Firearms</i> |
| 36..... | 6A 3.50, 8a 2.50. | 6 00... | <i>Fireball</i> |
| 48..... | 5A 4.00, 5a 3.00. | 7 00... | <i>Firebarrel</i> |
| 60..... | 4A 5.50, 5a 3.50. | 9 00... | <i>Firebell</i> |
| 72..... | 4A 5.70, 5a 3.80. | 9 50... | <i>Fireboat</i> |

| | | | |
|--------------------|-------------------------|-------------------------|--|
| Foot Slugs. | | <i>Firewood</i> | |
| BRASS: | | | |
| 12 Pt..... | Single Col. \$0 15..... | Double Col. \$0 25..... | |
| 18..... | 20..... | 30..... | |
| 24..... | 25..... | 35..... | |
| METAL: | | | |
| 12 Pt..... | 04..... | 06..... | |
| 18..... | 05..... | 07..... | |
| 24..... | 06..... | 08..... | |

| | | | |
|-------------------------|----------|-----------------|------------------|
| Foster Gothic. E | | <i>Firewood</i> | |
| 12 Pt..... | 14A..... | 2 25... | <i>Fireworks</i> |
| 18..... | 10A..... | 2 75... | <i>Firtot</i> |
| 24..... | 8A..... | 3 50... | <i>Firmament</i> |
| 30..... | 7A..... | 3 75... | <i>Firmans</i> |
| 36..... | 6A..... | 4 25... | <i>Firnest</i> |
| 48..... | 4A..... | 4 75... | <i>Firmitude</i> |

Franklin Old Style No. 79. A *Flagellant*

| | | |
|---------|--|---------------------------|
| 6 Pt. | 20A \$.50, 40A \$1.50, 100a \$1.60, \$3 60... | 4 17... <i>Flagolet</i> |
| 8..... | 20A .37, 40A 2.00, 90a 1.80. | 4 81... <i>Flagituros</i> |
| 10..... | 20A .60, 40A 2.21, 80a 2.00. | 5 21... <i>Flagman</i> |
| 12..... | 16A .75, 28A 2.39, 62a 2.07. | 5 21... <i>Flagship</i> |
| 14..... | 10A .62, 20A 1.99, 50a 2.60. | 5 06... <i>Flagstaff</i> |
| 18..... | 8A .60, 12A 2.15, 32a 2.31. | 5 99... <i>Flagstone</i> |
| 24..... | 8A 1.00, 12A 2.99, 28a 3.00. | 8 79... <i>Flagworm</i> |
| 36..... | 4A 1.19, 8A 4.00, 14a 3.60. | |

French Antique No. 110. D *Flatly*

| | | |
|---------|---------------------|---------------------------|
| 6 Pt. | 30A 1.30, 60a 1.30. | 2 60... <i>Flatness</i> |
| 8..... | 30A 1.35, 60a 1.35. | 2 70... <i>Flattened</i> |
| 10..... | 20A 1.25, 38a 1.25. | 2 50... <i>Flatterers</i> |
| 12..... | 20A 1.65, 38a 1.60. | 3 25... <i>Flattery</i> |
| 18..... | 10A 1.40, 16a 1.35. | 2 75... <i>Flatulence</i> |
| 20..... | 10A 1.50, 16a 1.50. | 3 00... <i>Flatuosity</i> |
| 30..... | 6A 2.30, 8a 2.30. | 4 60... <i>Flatus</i> |
| 36..... | 4A 2.80, 6a 2.80. | 5 60... <i>Flatwise</i> |
| 42..... | 4A 4.10, 5a 4.10. | 8 20... <i>Flawnt</i> |
| 48..... | 3A 4.15, 4a 4.10. | 8 25... <i>Flaunting</i> |

French Clarendon No. 120. E *Floriform*

| | | |
|---------|---------------------|----------------------------|
| 6 Pt. | 32A .95, 64a 1.15. | 2 10... <i>Floriken</i> |
| 8..... | 24A 1.00, 48a 1.30. | 2 30... <i>Florilege</i> |
| 10..... | 24A 1.15, 48a 1.50. | 2 65... <i>Florists</i> |
| 12..... | 18A 1.35, 36a 1.55. | 2 90... <i>Floscular</i> |
| 18..... | 12A 1.40, 24a 1.60. | 3 00... <i>Flotant</i> |
| 24..... | 12A 2.20, 24a 2.35. | 4 55... <i>Flotilla</i> |
| 30..... | 8A 2.15, 16a 2.50. | 4 65... <i>Flotsam</i> |
| 36..... | 6A 2.90, 12a 3.60. | 6 50... <i>Flounces</i> |
| 48..... | 4A 3.25, 8a 3.55. | 6 80... <i>Floundered</i> |
| 60..... | 3A 4.15, 6a 4.35. | 8 50... <i>Flourish</i> |
| 72..... | 3A 7.75, 5a 6.40. | 14 50... <i>Floutingly</i> |

French Clar. Ext'd No. 120. E *Followers*

| | | |
|---------|---------------------|---------------------------|
| 5 Pt. | 20A 1.35, 40a 1.50. | 2 85... <i>Fomalphant</i> |
| 6..... | 18A 1.10, 36a 1.20. | 2 30... <i>Fomenters</i> |
| 8..... | 18A 1.60, 36a 1.60. | 3 20... <i>Fondly</i> |
| 10..... | 16A 1.60, 32a 1.85. | 3 45... <i>Fondness</i> |
| 11..... | 12A 1.70, 24a 1.80. | 3 50... <i>Fondus</i> |
| 12..... | 10A 1.65, 20a 1.80. | 3 45... <i>Fontanel</i> |
| 18..... | 8A 2.05, 16a 2.65. | 4 70... <i>Fontanges</i> |
| 24..... | 6A 2.35, 12a 2.70. | 5 05... <i>Foodful</i> |
| 30..... | 4A 2.35, 8a 2.60. | 4 95... <i>Foodless</i> |
| 36..... | 3A 3.15, 6a 2.85. | 6 00... <i>Foolishly</i> |
| 42..... | 3A 5.10, 5a 3.75. | 8 85... <i>Foolscep</i> |

French Elzevir No. 1. A *Forehanded*

| | | |
|-------------|---------------------------|---------------------------|
| 6 Pt. (B15) | 20A, 30A 1.85, 100a 2.15. | 4 00... <i>Forehead</i> |
| 8..... | 20A, 40A 2.10, 90a 1.90. | 4 00... <i>Forehooks</i> |
| 10..... | 20A, 40A 2.75, 80a 2.00. | 4 75... <i>Foreign</i> |
| 12..... | 16A, 28A 3.00, 62a 2.00. | 5 00... <i>Foreigners</i> |
| 14..... | 10A, 20A 2.60, 50a 2.40. | 5 00... <i>Forejudged</i> |
| 18..... | 14A 2.81, 20a 1.50. | 4 31... <i>Foreknown</i> |
| 24..... | 8A 2.88, 10a 1.12. | 4 00... <i>Foreland</i> |
| 42..... | 5A 3.90, 6a 1.76. | 5 66... <i>Forelift</i> |
| 48..... | 4A 4.68, 5a 2.66. | 7 34... <i>Foremans</i> |

French Old Style Extended. E *Forfeited*

| | | |
|---------|---------------------|----------------------------|
| 10 Pt. | 18A 1.25, 36a 1.50. | 2 75... <i>Forfeited</i> |
| 12..... | 15A 1.30, 30a 1.45. | 2 75... <i>Forfeiting</i> |
| 18..... | 8A 1.50, 16a 1.50. | 3 00... <i>Forfeited</i> |
| 24..... | 6A 1.90, 12a 2.10. | 4 00... <i>Forgery</i> |
| 30..... | 5A 2.15, 10a 2.60. | 4 75... <i>Forgest</i> |
| 36..... | 4A 2.60, 8a 2.65. | 5 25... <i>Forget</i> |
| 48..... | 4A 3.75, 5a 3.75. | 7 50... <i>Forgetful</i> |
| 60..... | 4A 6.95, 5a 4.80. | 11 75... <i>Forgetteth</i> |
| 72..... | 3A 6.90, 5a 5.60. | 12 50... <i>Forgetting</i> |

French Old Style Italic No. 2. F *Forkiness*

| | | |
|---------|---------------------|---------------------------|
| 6 Pt. | 20A 1.00, 45a 1.25. | 2 25... <i>Forktail</i> |
| 7..... | 24A 1.00, 60a 1.50. | 2 50... <i>Fortornly</i> |
| 8..... | 24A 1.25, 60a 1.50. | 2 75... <i>Formalism</i> |
| 10..... | 20A 1.25, 50a 1.75. | 3 00... <i>Formality</i> |
| 12..... | 16A 1.50, 40a 2.00. | 3 50... <i>Formalized</i> |

French Old Style No. 1. F *Formidable*

| | | |
|---------|----------|---------------------------|
| 6 Pt. | 30A..... | 1 25... <i>Formless</i> |
| 8..... | 30A..... | 1 65... <i>Formula</i> |
| 10..... | 24A..... | 1 60... <i>Formulary</i> |
| 12..... | 20A..... | 1 55... <i>Formulated</i> |
| 14..... | 20A..... | 2 30... <i>Formulizes</i> |
| 16..... | 18A..... | 2 50... <i>Formyle</i> |
| 18..... | 18A..... | 2 50... <i>Fornay</i> |
| 20..... | 14A..... | 2 70... <i>Forsaken</i> |
| 24..... | 10A..... | 2 80... <i>Forsaking</i> |

French Old Style No. 1—Continued.

| | | |
|---------|---------|--------------------------|
| 30 Pt. | 7A..... | \$2 90... <i>Forsook</i> |
| 36..... | 5A..... | 3 00... <i>Forswear</i> |
| 48..... | 4A..... | 4 50... <i>Forswonk</i> |
| 60..... | 4A..... | 7 60... <i>Forsworc</i> |
| 72..... | 3A..... | 8 40... <i>Forswice</i> |

French Old Style No. 2. F *Forthgoing*

| | | |
|---------|-------------------------------------|----------------------------|
| 6 Pt. | 20A \$.60, 30A \$1.25, 100a \$2.15. | 4 00... <i>Forthwith</i> |
| 7..... | 15A .60, 30A 1.60, 90a 2.40. | 4 60... <i>Fortified</i> |
| 8..... | 15A .55, 30A 1.65, 90a 2.40. | 4 60... <i>Fortilage</i> |
| 10..... | 12A .50, 24A 1.60, 75a 2.60. | 4 70... <i>Fortissimo</i> |
| 12..... | 10A .55, 20A 1.55, 60a 2.90. | 5 00... <i>Fortitude</i> |
| 16..... | 18A 2.50, 36a 2.50. | 5 00... <i>Fortnight</i> |
| 18..... | 18A 2.50, 36a 2.50. | 5 00... <i>Fortress</i> |
| 20..... | 14A 2.70, 28a 2.80. | 5 50... <i>Fortuitous</i> |
| 24..... | 10A 2.80, 20a 2.95. | 5 75... <i>Fortunate</i> |
| 30..... | 7A 2.90, 12a 2.85. | 5 75... <i>Fortune</i> |
| 36..... | 5A 3.00, 9a 3.00. | 6 00... <i>Forzando</i> |
| 48..... | 4A 4.50, 7a 4.00. | 8 50... <i>Fossil</i> |
| 60..... | 4A 7.60, 5a 4.90. | 12 50... <i>Fossilized</i> |
| 72..... | 3A 8.40, 4a 5.60. | 14 00... <i>Fossors</i> |

French Script. C *Fougasse*

| | | | |
|---------|----------|-----------|----------------------------|
| 12 Pt. | 10A..... | 35a 2.40. | 4 00... <i>Foughten</i> |
| 14..... | 9A..... | 30a 3.05. | 5 00... <i>Foully</i> |
| 18..... | 8A..... | 24a 3.40. | 6 00... <i>Foulness</i> |
| 22..... | 7A..... | 22a 3.90. | 7 25... <i>Foulspeakcn</i> |
| 28..... | 6A..... | 18a 4.90. | 8 90... <i>Fountain</i> |
| 36..... | 5A..... | 14a 6.25. | 10 75... <i>Foundation</i> |
| 44..... | 4A..... | 12a 6.65. | 11 25... <i>Founder</i> |
| 54..... | 3A..... | 9a 7.10. | 12 20... <i>Foundlings</i> |

Full Face No. 123. E *Frankish*

| | | |
|---------|---------------------|---------------------------|
| 5½ Pt. | 24A 1.25, 48a 1.50. | 2 75... <i>Frankly</i> |
| 6..... | 24A 1.15, 48a 1.40. | 2 55... <i>Frankness</i> |
| 7..... | 24A 1.25, 48a 1.55. | 2 80... <i>Franktely</i> |
| 8..... | 24A 1.50, 48a 1.75. | 3 25... <i>Frapter</i> |
| 9..... | 18A 1.15, 36a 1.40. | 2 55... <i>Fraternal</i> |
| 10..... | 18A 1.30, 36a 1.45. | 2 75... <i>Fraternism</i> |
| 11..... | 18A 1.35, 36a 1.60. | 2 95... <i>Fraternity</i> |
| 12..... | 12A 1.20, 24a 1.40. | 2 60... <i>Fratrage</i> |
| 14..... | 12A 1.55, 24a 1.85. | 3 40... <i>Fratricide</i> |
| 18..... | 10A 2.00, 20a 2.25. | 4 25... <i>Fraudful</i> |
| 24..... | 8A 2.10, 16a 2.60. | 4 70... <i>Fraudfully</i> |
| 30..... | 6A 2.60, 12a 3.20. | 5 80... <i>Fraudless</i> |
| 42..... | 4A 3.15, 8a 3.65. | 6 80... <i>Fraudulent</i> |
| 48..... | 3A 4.55, 6a 4.65. | 9 20... <i>Frazinine</i> |

Full-Face Fractions No. 7. F

| | | |
|--------|-------------|-------------------------|
| 6 Pt. | 1-lb. font, | 1 16... <i>Freeborn</i> |
| 8..... | | 90... <i>Freedom</i> |

Full-Face Italic No. 123. E *Freevarren*

| | | |
|---------|---------------------|---------------------------|
| 5½ Pt. | 24A 1.20, 48a 1.45. | 2 65... <i>Freewill</i> |
| 6..... | 24A 1.15, 48a 1.45. | 2 60... <i>Freezeth</i> |
| 8..... | 18A 1.25, 36a 1.35. | 2 60... <i>Freezing</i> |
| 9..... | 18A 1.25, 36a 1.40. | 2 65... <i>Freightcar</i> |
| 10..... | 18A 1.55, 36a 1.65. | 3 20... <i>Freighters</i> |
| 11..... | 18A 1.55, 36a 1.75. | 3 30... <i>Frenzical</i> |
| 12..... | 12A 1.30, 24a 1.35. | 2 65... <i>Frenziedly</i> |

FURNITURE, METAL (see Metal Furniture).

Geometric. F *Gallooned*

| | | |
|-------------|---------------------------|--------------------------|
| 6 Pt. | 16A 1.25, 50a 1.50. | 2 75... <i>Gallop</i> |
| 6 No. 2 16A | 1.00, 16A 1.20, 50a 1.30. | 3 50... <i>Gallopade</i> |
| 8..... | 16A 1.60, 50a 1.90. | 3 50... <i>Galloping</i> |
| 10..... | 13A 1.65, 40a 1.85. | 3 50... <i>Galloway</i> |
| 12..... | 12A 1.90, 34a 2.10. | 4 00... <i>Gallows</i> |
| 18..... | 10A 2.00, 24a 2.50. | 4 50... <i>Gallstone</i> |
| 24..... | 10A 2.90, 15a 2.10. | 5 00... <i>Gallyworm</i> |

Geometric Italic. F *Gambison*

| | | |
|-------------|---------------------------|---------------------------|
| 6 Pt. | 16A 1.25, 50a 1.50. | 2 75... <i>Gambit</i> |
| 6 No. 2 16A | 1.00, 16A 1.20, 50a 1.30. | 3 50... <i>Gamblers</i> |
| 8..... | 16A 1.60, 50a 1.90. | 3 50... <i>Gamboge</i> |
| 10..... | 13A 1.65, 40a 1.85. | 3 50... <i>Gambogian</i> |
| 12..... | 12A 1.90, 34a 2.10. | 4 00... <i>Gambolled</i> |
| 18..... | 10A 2.00, 24a 2.50. | 4 50... <i>Gambolling</i> |
| 24..... | 10A 2.90, 15a 2.10. | 5 00... <i>Gambrel</i> |

German. B-E

| | | | |
|-----------------|----------------|-----------------|----------------------------|
| 18 Pt. No. 121. | 20A..... | 100a..... | 12 48... <i>Gambroons</i> |
| 24..... | 121...14A..... | 40a..... | 12 00... <i>Gamecock</i> |
| 30..... | 121...8A..... | 60a..... | 12 00... <i>Gamekeeper</i> |
| 42..... | 31...4A..... | 3.50, 10a 4.00. | 7 50... <i>Game laws</i> |
| 42..... | 32...4A..... | 3.75, 10a 4.25. | 8 00... <i>Gamester</i> |
| 48..... | 31...5A..... | 4.75, 10a 4.75. | 9 50... <i>Gameins</i> |
| 60..... | 30...4A..... | 5.00, 8a 5.50. | 10 50... <i>Gammurcus</i> |

GERMAN BODY TYPE (sold at Roman prices).

| | | | | | | | |
|----------------------------|-----|-------------|----------|-----------------|-------------------|--|--|
| German Full-Face. F | | | | <i>Gangrene</i> | | | |
| 6 Pt..... | 16A | \$1.25, 50a | \$1.75.. | 3 00... | <i>Gangrenous</i> | | |
| 7..... | 16A | 1.40, 50a | 1.85.. | 3 25... | <i>Gangtide</i> | | |
| 8..... | 16A | 1.50, 50a | 2.00.. | 3 50... | <i>Gangtooth</i> | | |
| 9..... | 16A | 1.70, 50a | 2.15.. | 3 85... | <i>Gangue</i> | | |
| 10..... | 12A | 1.50, 40a | 2.00.. | 3 50... | <i>Gangway</i> | | |
| 11..... | 9A | 1.00, 30a | 2.00.. | 3 00... | <i>Gangweck</i> | | |
| 12..... | 7A | 1.35, 20a | 1.65.. | 3 00... | <i>Ganil</i> | | |
| 18..... | 7A | 1.85, 20a | 2.65.. | 4 50... | <i>Gannet</i> | | |
| 24..... | 6A | 3.30, 15a | 2.70.. | 6 00... | <i>Ganoidal</i> | | |
| 30..... | 6A | 3.80, 15a | 4.20.. | 8 00... | <i>Ganoidian</i> | | |

| | | | | | | | |
|---------------------------|----|-----------|--------|-----------------|-----------------|--|--|
| German Gothisch. B | | | | <i>Gantlope</i> | | | |
| 12 Pt..... | 9A | 1.20, 30a | 1.40.. | 2 60... | <i>Gantois</i> | | |
| 18..... | 8A | 1.50, 25a | 1.50.. | 3 00... | <i>Gaoler</i> | | |
| 24..... | 7A | 1.70, 20a | 1.70.. | 3 40... | <i>Gaptoot</i> | | |
| 30..... | 6A | 2.00, 15a | 2.00.. | 4 00... | <i>Garacine</i> | | |
| 42..... | 4A | 3.15, 10a | 3.10.. | 6 25... | <i>Garbage</i> | | |
| 48..... | 4A | 3.25, 10a | 3.30.. | 6 55... | <i>Garbled</i> | | |
| 60..... | 4A | 4.30, 10a | 4.35.. | 8 65... | <i>Garboil</i> | | |

| | | | | | | | |
|----------------------------|-----|-----------|--------|----------------|-------------------|--|--|
| Germania No. 150. F | | | | <i>Garment</i> | | | |
| 9 Pt..... | 14A | 1.30, 42a | 1.95.. | 3 25... | <i>Garmented</i> | | |
| 12..... | 13A | 1.35, 40a | 2.35.. | 3 70... | <i>Garner</i> | | |
| 18..... | 10A | 1.55, 30a | 2.35.. | 3 90... | <i>Garnered</i> | | |
| 16..... | 8A | 1.60, 24a | 2.90.. | 4 50... | <i>Garnet</i> | | |
| 18..... | 7A | 2.00, 20a | 3.10.. | 5 10... | <i>Garrisoned</i> | | |
| 24..... | 5A | 2.40, 15a | 3.35.. | 5 75... | <i>Garron</i> | | |
| 30..... | 4A | 2.60, 10a | 3.40.. | 6 00... | <i>Garroted</i> | | |
| 36..... | 3A | 2.85, 7a | 3.15.. | 6 00... | <i>Garrutity</i> | | |

| | | | | | | | |
|-----------------------------|----|-----------|--------|-------------------|-------------------|--|--|
| German Text No. 2. B | | | | <i>Gastronome</i> | | | |
| 12 Pt..... | 9A | 1.75, 30a | 1.25.. | 3 00... | <i>Gastropod</i> | | |
| 14..... | 8A | 1.95, 25a | 1.50.. | 3 45... | <i>Gasworks</i> | | |
| 18..... | 7A | 1.90, 20a | 1.60.. | 3 50... | <i>Gatehouse</i> | | |
| 24..... | 5A | 2.20, 15a | 1.75.. | 3 95... | <i>Gateway</i> | | |
| 30..... | 4A | 2.00, 10a | 1.85.. | 3 85... | <i>Gathered</i> | | |
| 42..... | 3A | 2.35, 6a | 2.00.. | 4 35... | <i>Gatherings</i> | | |

| | | | | | | | |
|------------------------|-----|-----------|--------|------------------|-------------------|--|--|
| German Title. B | | | | <i>Gaucherie</i> | | | |
| 6 Pt..... | 15A | 1.00, 50a | 1.25.. | 2 25... | <i>Gaicho</i> | | |
| 7..... | 15A | 1.05, 50a | 1.20.. | 2 25... | <i>Gaudiest</i> | | |
| 8..... | 15A | 1.90, 50a | 1.45.. | 3 35... | <i>Gaudily</i> | | |
| 9..... | 15A | 1.45, 50a | 1.60.. | 3 05... | <i>Gauidness</i> | | |
| 10..... | 12A | 1.30, 40a | 1.70.. | 3 00... | <i>Gauffering</i> | | |
| 11..... | 9A | 1.05, 30a | 1.30.. | 2 35... | <i>Gauger</i> | | |
| 12..... | 9A | 1.35, 30a | 1.65.. | 3 00... | <i>Gauilish</i> | | |
| 14..... | 8A | 1.25, 25a | 1.75.. | 3 00... | <i>Gauntlet</i> | | |
| 18..... | 7A | 1.75, 20a | 1.95.. | 3 70... | <i>Gauntry</i> | | |
| 24..... | 7A | 2.40, 20a | 2.80.. | 5 20... | <i>Gawzeloorn</i> | | |
| 30..... | 4A | 2.10, 10a | 2.00.. | 4 10... | <i>Gavelkind</i> | | |
| 36..... | 4A | 3.35, 10a | 3.35.. | 6 70... | <i>Gavelocks</i> | | |
| 48..... | 4A | 5.15, 10a | 5.00.. | 10 15... | <i>Gavial</i> | | |
| 60..... | 3A | 5.35, 6a | 5.00.. | 10 35... | <i>Gavilan</i> | | |

| | | | | | | | |
|------------------------------|-----|-----------|--------|---------------|-------------------|--|--|
| German Title No. 2. B | | | | <i>Gavots</i> | | | |
| 8 Pt..... | 15A | 1.00, 50a | 1.50.. | 2 50... | <i>Gavkiest</i> | | |
| 10..... | 12A | 1.30, 40a | 1.15.. | 2 45... | <i>Gawntree</i> | | |
| 12..... | 9A | 1.00, 30a | 1.65.. | 2 65... | <i>Gaydiang</i> | | |
| 14..... | 8A | 1.05, 25a | 1.65.. | 2 70... | <i>Gayely</i> | | |
| 18..... | 7A | 1.40, 20a | 1.75.. | 3 15... | <i>Gaytussite</i> | | |
| 24..... | 7A | 2.25, 20a | 2.50.. | 4 75... | <i>Gayness</i> | | |
| 30..... | 4A | 1.85, 10a | 1.95.. | 3 80... | <i>Gaysome</i> | | |

| | | | | | | | |
|--------------------------------|-----|-----------|--------|---------------|-------------------|--|--|
| German Title No. 122. E | | | | <i>Gazebo</i> | | | |
| 6 Pt..... | 15A | .90, 50a | 1.95.. | 2 85... | <i>Gazeful</i> | | |
| 7..... | 15A | .90, 50a | 2.20.. | 3 10... | <i>Gazehound</i> | | |
| 8..... | 15A | .95, 50a | 2.20.. | 3 15... | <i>Gazelle</i> | | |
| 9..... | 15A | 1.15, 50a | 2.80.. | 3 95... | <i>Gazement</i> | | |
| 10..... | 12A | .95, 40a | 2.05.. | 3 00... | <i>Gazers</i> | | |
| 11..... | 9A | .75, 30a | 1.85.. | 2 60... | <i>Gazettell</i> | | |
| 12..... | 9A | .90, 30a | 2.20.. | 3 10... | <i>Gecko</i> | | |
| 14..... | 8A | 1.00, 25a | 2.25.. | 3 25... | <i>Gehema</i> | | |
| 18..... | 7A | 1.10, 20a | 2.40.. | 3 50... | <i>Gelatinate</i> | | |
| 24..... | 7A | 1.50, 20a | 3.25.. | 4 75... | <i>Gelatine</i> | | |
| 30..... | 4A | 1.65, 10a | 3.15.. | 4 80... | <i>Gelatnize</i> | | |
| 36..... | 3A | 1.50, 6a | 2.45.. | 3 95... | <i>Geldervose</i> | | |
| 42..... | 3A | 2.15, 6a | 3.20.. | 5 35... | <i>Geldings</i> | | |

| | | | | | | | |
|-------------------------------------|-----|----------|--------|------------------|------------------|--|--|
| German Title Cond. No. 30. B | | | | <i>Gelidness</i> | | | |
| 6 Pt..... | 15A | .90, 50a | 1.10.. | 2 00... | <i>Gelidness</i> | | |

| | | | | | | | |
|--------------------------------------|-----|-----------|--------|---------------|-----------------|--|--|
| German Title Cond. No. 150. F | | | | <i>Genius</i> | | | |
| 8 Pt..... | 16A | 1.05, 50a | 1.95.. | 3 00... | <i>Genteel</i> | | |
| 9..... | 16A | 1.15, 50a | 2.00.. | 3 15... | <i>Genteely</i> | | |
| 10..... | 16A | 1.30, 50a | 2.20.. | 3 50... | <i>Gentian</i> | | |

German Title Cond. No. 150—Continued.

| | | | | | | | |
|------------|-----|-------------|----------|-----------|-------------------|--|--|
| 11 Pt..... | 16A | \$1.25, 50a | \$2.50.. | \$3 75... | <i>Gentiles</i> | | |
| 12..... | 16A | 2.00, 50a | 2.50.. | 4 50... | <i>Gentilism</i> | | |
| 14..... | 12A | 1.70, 40a | 2.30.. | 4 00... | <i>Gentility</i> | | |
| 18..... | 9A | 2.40, 30a | 2.10.. | 4 50... | <i>Gentilized</i> | | |
| 20..... | 8A | 2.25, 24a | 3.50.. | 5 75... | <i>Gentlefolk</i> | | |
| 30..... | 8A | 3.05, 20a | 3.55.. | 6 60... | <i>Gentleman</i> | | |
| 36..... | 5A | 3.90, 15a | 3.85.. | 7 75... | <i>Gentleness</i> | | |
| 42..... | 4A | 5.00, 10a | 5.00.. | 10 00... | <i>Gently</i> | | |
| 60..... | 4A | 6.00, 10a | 7.00.. | 13 00... | <i>Gentoos</i> | | |
| 72..... | 3A | 6.00, 8a | 6.00.. | 12 00... | <i>Genuine</i> | | |

| | | | | | | | |
|----------------|-----|--|--|----------------|------------------|--|--|
| Goth. B | | | | <i>Girrock</i> | | | |
| 6 Pt..... | 50A | | | 2 00... | <i>Girths</i> | | |
| 8..... | 40A | | | 2 25... | <i>Girting</i> | | |
| 10..... | 30A | | | 2 25... | <i>Gittersns</i> | | |
| 12..... | 30A | | | 2 65... | <i>Giusto</i> | | |
| 18..... | 18A | | | 3 15... | <i>Givers</i> | | |
| 24..... | 12A | | | 3 35... | <i>Giveth</i> | | |

| | | | | | | | |
|-------------------------|-----|-----------|---------|-----------------|-------------------|--|--|
| Gotham Script. B | | | | <i>Glabrite</i> | | | |
| 12 Pt..... | 12A | 3.00, 50a | 6.00.. | 9 00... | <i>Glabrous</i> | | |
| | 8A | 2.80, 30a | 3.20.. | 6 00... | <i>Glacial</i> | | |
| | 4A | 1.40, 15a | 1.60.. | 3 00... | <i>Glacialist</i> | | |
| 18..... | 12A | 5.25, 50a | 7.50.. | 12 75... | <i>Glaciation</i> | | |
| | 8A | 3.30, 20a | 3.20.. | 6 50... | <i>Glacis</i> | | |
| | 4A | 1.65, 10a | 1.60.. | 3 25... | <i>Gladden</i> | | |
| 24..... | 12A | 7.80, 50a | 11.55.. | 19 35... | <i>Gladdeneth</i> | | |
| | 8A | 5.20, 20a | 4.70.. | 9 90... | <i>Gladful</i> | | |
| | 4A | 2.60, 10a | 2.35.. | 4 95... | <i>Gladiolus</i> | | |

| | | | | | | | |
|----------------------------------|-------------|--|--|----------------|-------------------|--|--|
| Gothic Cond. Fractions. B | | | | <i>Glander</i> | | | |
| 12 Pt..... | 1 lb. font, | | | 66.. | <i>Glander</i> | | |
| 18..... | 1..... | | | 60.. | <i>Glandiform</i> | | |
| 24..... | 1..... | | | 56.. | <i>Glandular</i> | | |
| 36..... | 1..... | | | 56.. | <i>Glandulose</i> | | |

| | | | | | | | |
|-------------------------------|-----|-----------|-----------|-------------------|------------------|-------------------|--|
| Gothic Cond. No. 37. B | | | | <i>Glossology</i> | | | |
| 10 Pt..... | 20A | .65, 25A | 1.35, 40a | 1.15.. | 3 15... | <i>Glossotomy</i> | |
| 12..... | 12A | .50, 20A | 1.40, 30a | 1.10.. | 3 00... | <i>Glottal</i> | |
| 18..... | 10A | .75, 15A | 1.95, 25a | 1.50.. | 4 20... | <i>Glottalite</i> | |
| 20..... | 8A | .85, 12A | 2.50, 20a | 2.00.. | 5 35... | <i>Glottis</i> | |
| 30..... | 10A | 2.95, 15a | 2.40.. | 5 35... | <i>Gloved</i> | | |
| 36..... | 8A | 3.75, 12a | 2.80.. | 6 55... | <i>Glowingly</i> | | |
| 42..... | 6A | 4.00, 10a | 2.90.. | 6 90... | <i>Glowworm</i> | | |
| 48..... | 6A | 5.55, 10a | 4.20.. | 9 75... | <i>Gloxinia</i> | | |
| 60..... | 5A | 6.50, 6a | 4.30.. | 10 80... | <i>Glucic</i> | | |
| 72..... | 4A | 8.20, 6a | 5.95.. | 14 15... | <i>Glucina</i> | | |

| | | | | | | | |
|--------------------------------|-----|-----------|--------|---------------|-------------------|--|--|
| Gothic Cond. No. 112. A | | | | <i>Gotten</i> | | | |
| 8 Pt..... | 40A | 1.50, 62a | 1.20.. | 2 70... | <i>Gougubit</i> | | |
| 10..... | 28A | 1.30, 44a | 1.20.. | 2 50... | <i>Gouges</i> | | |
| 12..... | 24A | 1.75, 36a | 1.33.. | 3 08... | <i>Goujeers</i> | | |
| 18..... | 16A | 1.50, 24a | 1.70.. | 3 20... | <i>Gouland</i> | | |
| 24..... | 12A | 2.09, 20a | 1.66.. | 3 75... | <i>Gourdiness</i> | | |

| | | | | | | | |
|--------------------------------|-----|-----------|--------|---------------|--------------------|--|--|
| Gothic Cond. No. 122. E | | | | <i>Grails</i> | | | |
| 10 Pt..... | 20A | 0.80, 40a | 0.95.. | 1 75... | <i>Grainers</i> | | |
| 12..... | 18A | 1.05, 36a | 1.25.. | 2 30... | <i>Grainmoth</i> | | |
| | 10A | | | 50.. | <i>Grainstaff</i> | | |
| 18..... | 12A | 1.25, 24a | 1.55.. | 2 80... | <i>Grallie</i> | | |
| | 8A | | | 70.. | <i>Gramarye</i> | | |
| 20..... | 10A | 1.40, 20a | 1.70.. | 3 10... | <i>Gramineal</i> | | |
| | 8A | | | 1 00... | <i>Gramineous</i> | | |
| 24..... | 10A | 1.75, 20a | 2.10.. | 3 85... | <i>Grammar</i> | | |
| | 6A | | | 1 05... | <i>Grammarians</i> | | |
| 36..... | 8A | 2.85, 16a | 3.55.. | 6 40... | <i>Grammatic</i> | | |
| | 5A | | | 1 45... | <i>Grammes</i> | | |
| 42..... | 6A | 2.70, 12a | 3.20.. | 5 90... | <i>Grammite</i> | | |
| | 5A | | | 2 05... | <i>Grampus</i> | | |
| 48..... | 4A | 3.05, 8a | 3.05.. | 6 10... | <i>Grandadilla</i> | | |
| | 5A | | | 2 65... | <i>Grandam</i> | | |
| 60..... | 3A | 3.95, 6a | 3.75.. | 7 70... | <i>Grandchild</i> | | |
| | 3A | | | 2 90... | <i>Grandeas</i> | | |
| 72..... | 3A | 5.50, 6a | 5.35.. | 10 85... | <i>Grandeur</i> | | |
| | 3A | | | 4 25... | <i>Grandevity</i> | | |

| | | | | | | | |
|--------------------------------|-----|-----------|--------|-------------------|-------------------|--|--|
| Gothic Cond. No. 123. E | | | | <i>Grandifite</i> | | | |
| 6 Pt..... | 32A | 1.05, 64a | 1.30.. | 2 35... | <i>Grandinous</i> | | |
| 8..... | 32A | 1.25, 64a | 1.55.. | 2 80... | <i>Grandiose</i> | | |
| 10..... | 24A | 1.15, 48a | 1.40.. | 2 55... | <i>Grandly</i> | | |
| 12..... | 18A | 1.15, 36a | 1.40.. | | | | |

Gothic Cond. No. 124. £

| | | | |
|-----------|-------------------------|--------|-------------------|
| 6 Pt..... | 32A \$1.10, 64a \$1.20. | \$2 30 | <i>Granitine</i> |
| 8..... | 32A 1.30, 64a 1.55. | 2 85 | <i>Granitoid</i> |
| 10..... | 24A 1.20, 48a 1.45. | 2 65 | <i>Gravator</i> |
| 12..... | 18A 1.25, 36a 1.40. | 2 65 | <i>Gravular</i> |
| 18..... | 12A 1.35, 24a 1.70. | 3 05 | <i>Granulated</i> |
| 24..... | 12A 2.05, 24a 2.40. | 4 45 | <i>Granules</i> |
| 30..... | 8A 1.90, 16a 2.45. | 4 35 | <i>Graperies</i> |
| 36..... | 6A 2.40, 12a 3.10. | 5 50 | <i>Grapeshot</i> |
| 42..... | 4A 2.25, 8a 2.80. | 5 05 | <i>Grapesugar</i> |
| 48..... | 4A 3.00, 8a 3.40. | 6 40 | <i>Grapevine</i> |

Gothic Cond. No. 127. £

| | | | |
|--------------------|-----|------|-------------------|
| 5 Pt. on 6 Pt..... | 56A | 1 30 | <i>Grapple</i> |
| 6..... | 48A | 1 25 | <i>Grappled</i> |
| 8..... | 42A | 1 35 | <i>Grappling</i> |
| 10..... | 36A | 1 40 | <i>Grapsus</i> |
| 12..... | 32A | 1 80 | <i>Graspable</i> |
| 16..... | 24A | 1 95 | <i>Grasped</i> |
| 18..... | 18A | 1 90 | <i>Graspingly</i> |
| 20..... | 16A | 2 10 | <i>Grassation</i> |
| 24..... | 12A | 2 15 | <i>Grassgrown</i> |
| 30..... | 10A | 2 30 | <i>Grassmoth</i> |
| 36..... | 8A | 2 45 | <i>Grasspot</i> |
| 42..... | 5A | 2 40 | <i>Grasspoly</i> |
| 48..... | 4A | 3 00 | <i>Grassvetch</i> |

Gothic Cond. No. 128. £

| | | | |
|--------------------|-----|------|-------------------|
| 5 Pt. on 6 Pt..... | 56A | 1 45 | <i>Grateful</i> |
| 6..... | 48A | 1 55 | <i>Gratelupia</i> |
| 8..... | 42A | 1 65 | <i>Gratified</i> |
| 10..... | 36A | 1 70 | <i>Gratifying</i> |
| 12..... | 32A | 2 10 | <i>Gratings</i> |
| 16..... | 24A | 2 10 | <i>Gratitude</i> |
| 18..... | 18A | 2 10 | <i>Gratuitous</i> |
| 20..... | 16A | 2 45 | <i>Gratuity</i> |
| 24..... | 12A | 2 25 | <i>Grawacke</i> |
| 30..... | 10A | 2 65 | <i>Gravamen</i> |
| 36..... | 8A | 3 10 | <i>Gravel</i> |
| 42..... | 5A | 2 80 | <i>Gravelly</i> |
| 48..... | 4A | 3 55 | <i>Gravelpit</i> |

Gothic Cond. No. 129. £

| | | | |
|------------|---------------------|-------|-------------------|
| 10 Pt..... | 20A .80, 40a .95. | 1 75 | <i>Graveness</i> |
| 12..... | 20A 1.05, 30a .80. | 1 85 | <i>Graveolent</i> |
| 18..... | 15A 1.10, 25a 1.00. | 2 10 | <i>Gravers</i> |
| 20..... | 15A 1.55, 20a 1.10. | 2 65 | <i>Gravestone</i> |
| 24..... | 15A 2.25, 20a 1.75. | 4 00 | <i>Graveyard</i> |
| 36..... | 10A 2.70, 12a 1.90. | 4 60 | <i>Gravid</i> |
| 42..... | 10A 3.60, 12a 2.30. | 5 90 | <i>Gravidated</i> |
| 48..... | 6A 3.50, 10a 2.85. | 6 35 | <i>Gravigrade</i> |
| 60..... | 4A 6a..... | 8 50 | <i>Gravimeter</i> |
| 72..... | 4A 6a..... | 11 50 | <i>Gravitates</i> |

Gothic Extra Cond. No. 122. £

| | | | |
|------------|---------------------|-------|-------------------|
| 12 Pt..... | 18A 1.10, 36a 1.25. | 2 35 | <i>Growingly</i> |
| 18..... | 16A 1.70, 32a 2.10. | 3 80 | <i>Grows</i> |
| 20..... | 12A 1.85, 24a 2.15. | 4 00 | <i>Growth</i> |
| 24..... | 10A 2.00, 20a 2.20. | 4 20 | <i>Growthhead</i> |
| 30..... | 8A 2.20, 16a 2.60. | 4 80 | <i>Groyne</i> |
| 36..... | 6A 2.20, 12a 2.60. | 4 80 | <i>Grozzer</i> |
| 42..... | 6A 3.20, 12a 3.70. | 6 90 | <i>Grubaxe</i> |
| 48..... | 6A 4.25, 12a 4.95. | 9 20 | <i>Grudge</i> |
| 60..... | 5A 4.45, 10a 5.20. | 9 65 | <i>Grudgeful</i> |
| 72..... | 4A 5.15, 8a 5.60. | 10 75 | <i>Grudgeth</i> |

Gothic Extra Cond. No. 150. A-F

| | | | |
|-----------|---------------------|------|-----------------|
| 8 Pt..... | 22A 1.35, 32a 1.15. | 2 50 | <i>Grumose</i> |
| 10..... | 20A 1.40, 38a 1.35. | 2 75 | <i>Grumpily</i> |
| 12..... | 20A 1.50, 40a 1.50. | 3 00 | <i>Grumpy</i> |
| 18..... | 18A 2.00, 24a 1.25. | 3 25 | <i>Grunted</i> |
| 24..... | 12A 2.00, 18a 1.50. | 3 50 | <i>Grunting</i> |
| 30..... | 10A 2.40, 16a 2.10. | 4 50 | <i>Grunts</i> |
| 42..... | 6A 9a..... | 4 50 | <i>Gryffon</i> |
| 48..... | 5A 8a..... | 5 00 | <i>Gryllus</i> |

Gothic Fractions. B

| | | | |
|-----------|-------------|------|-------------------|
| 6 Pt..... | 1 lb. font, | 1 16 | <i>Guardful</i> |
| 12..... | 1..... | 66 | <i>Guardfully</i> |
| 18..... | 1..... | 60 | <i>Guardians</i> |

Gothic Italic Nos. 112 and 113. D

| | | | |
|--------------------|--------------------------|------|-------------------|
| 6 Pt. No. 113..... | 30A 1.20, 60a 1.20. | 2 40 | <i>Guillily</i> |
| 8..... | 112. 36A 1.30, 52a 1.30. | 2 60 | <i>Guillless</i> |
| 10..... | 112. 30A 1.30, 42a 1.30. | 2 60 | <i>Guimbard</i> |
| 12..... | 112. 22A 1.25, 38a 1.25. | 2 50 | <i>Guinea</i> |
| 18..... | 112. 18A 1.40, 25a 1.40. | 2 80 | <i>Guineafovl</i> |
| 20..... | 112. 18A 1.80, 24a 1.85. | 3 65 | <i>Guineahen</i> |
| 30..... | 112. 10A 2.25, 14a 2.25. | 4 50 | <i>Guineapig</i> |

Gothic Italic No. 123. £

| | | | |
|------------|------------------------|--------|-----------------|
| 36 Pt..... | 5A \$2.75, 10a \$3.65. | \$6 40 | <i>Guisard</i> |
| 48..... | 4A 3.55, 8a 4.25. | 7 80 | <i>Guisette</i> |
| 60..... | 3A 4.70, 6a 4.90. | 9 60 | <i>Guitar</i> |

Gothic Italic No. 124. £

| | | | |
|--------------------|---------------------|------|------------------|
| 5 Pt. on 6 Pt..... | 32A .85, 64a 1.10. | 1 95 | <i>Gullyhole</i> |
| 6..... | 32A .95, 64a 1.30. | 2 25 | <i>Gulosity</i> |
| 8..... | 24A 0.95, 48a 1.25. | 2 20 | <i>Gulped</i> |
| 10..... | 24A 1.15, 48a 1.50. | 2 65 | <i>Gulping</i> |
| 12..... | 18A 1.15, 36a 1.40. | 2 55 | <i>Gumboil</i> |
| 18..... | 12A 1.30, 24a 1.65. | 2 95 | <i>Gumcistus</i> |
| 24..... | 10A 1.45, 20a 1.75. | 3 20 | <i>Gunned</i> |
| | 10A..... | 1 15 | <i>Gumminess</i> |
| | | | <i>Gummosity</i> |
| | | | <i>Gummosous</i> |
| | | | <i>Gumption</i> |
| | | | <i>Gumrush</i> |
| | | | <i>Gumresin</i> |
| | | | <i>Gumtree</i> |

Gothic Italic Extra Cond. F

| | | | |
|-----------|---------------------|------|-------------------|
| 6 Pt..... | 28A 1.30, 40a 1.20. | 2 50 | <i>Guttural</i> |
| 8..... | 26A 1.50, 38a 1.50. | 3 00 | <i>Gutturine</i> |
| 10..... | 24A 1.65, 36a 1.60. | 3 25 | <i>Gutturized</i> |
| 12..... | 20A 1.70, 30a 1.70. | 3 40 | <i>Gutwort</i> |
| 16..... | 18A 2.00, 24a 1.75. | 3 75 | <i>Guylen</i> |
| 20..... | 15A 2.10, 20a 1.90. | 4 00 | <i>Guzzlers</i> |
| 24..... | 12A 2.25, 16a 2.00. | 4 25 | <i>Gwimiad</i> |
| 30..... | 10A 2.50, 14a 2.50. | 5 00 | <i>Gymnasium</i> |
| 36..... | 9A 3.10, 12a 2.90. | 6 00 | <i>Gymnastics</i> |
| 42..... | 8A 3.90, 10a 3.10. | 7 00 | <i>Gymnic</i> |

Gothic No. 122. £

| | | | |
|-----------|---------------------|------|-------------------|
| 5 Pt..... | 24A 1.30, 48a 1.60. | 2 90 | <i>Haridest</i> |
| 6..... | 24A 1.15, 48a 1.50. | 2 65 | <i>Hardiment</i> |
| 8..... | 24A 1.55, 48a 1.90. | 3 45 | <i>Hardiron</i> |
| 10..... | 18A 1.45, 36a 1.70. | 3 15 | <i>Hardtack</i> |
| 12..... | 16A 1.70, 32a 1.95. | 3 65 | <i>Harebell</i> |
| 18..... | 10A 1.50, 20a 1.65. | 3 15 | <i>Harefoots</i> |
| 20..... | 10A 2.30, 20a 2.60. | 4 90 | <i>Harehound</i> |
| 24..... | 8A 2.55, 16a 2.80. | 5 35 | <i>Haretip</i> |
| 30..... | 5A 2.90, 10a 2.45. | 5 35 | <i>Haretilled</i> |
| 36..... | 4A 3.15, 8a 3.45. | 6 60 | <i>Haremint</i> |
| 42..... | 4A 4.00, 8a 4.00. | 6 60 | <i>Harems</i> |
| 48..... | 3A 4.75, 6a 4.50. | 7 05 | <i>Harepipe</i> |
| | | | <i>Harfang</i> |
| | | | <i>Harmaline</i> |
| | | | <i>Harmattan</i> |
| | | | <i>Harmful</i> |
| | | | <i>Harmfully</i> |
| | | | <i>Harmless</i> |
| | | | <i>Harmlessly</i> |
| | | | <i>Harmonic</i> |
| | | | <i>Harmonists</i> |
| | | | <i>Harmonized</i> |

Gothic No. 123. £

| | | | |
|-----------|---------------------|------|-------------------|
| 6 Pt..... | 32A 1.15, 64a 1.45. | 2 60 | <i>Harpagon</i> |
| 8..... | 24A 1.15, 48a 1.35. | 2 50 | <i>Harpies</i> |
| 10..... | 20A 1.25, 40a 1.40. | 2 65 | <i>Harpings</i> |
| 12..... | 18A 1.55, 36a 1.85. | 3 40 | <i>Harpooner</i> |
| 18..... | 12A 1.75, 24a 2.05. | 3 80 | <i>Harpoon</i> |
| 24..... | 10A 2.15, 20a 2.60. | 4 75 | <i>Harpischon</i> |
| 30..... | 6A 2.75, 12a 3.50. | 6 25 | <i>Harquebuse</i> |
| 36..... | 5A 3.25, 10a 3.80. | 7 05 | <i>Harrages</i> |
| 48..... | 4A 4.25, 8a 4.75. | 9 00 | <i>Harrateen</i> |
| | | | <i>Harridan</i> |

Gothic No. 124. £

| | | | |
|-----------|---------------------|------|-------------------|
| 6 Pt..... | 32A 1.00, 64a 1.15. | 2 15 | <i>Harrowed</i> |
| 8..... | 24A .95, 48a 1.10. | 2 05 | <i>Harrysoph</i> |
| 10..... | 20A 1.00, 40a 1.10. | 2 10 | <i>Harshly</i> |
| 12..... | 18A 1.25, 36a 1.25. | 2 50 | <i>Harshness</i> |
| 18..... | 12A 1.65, 24a 1.85. | 3 50 | <i>Hartbeest</i> |
| 24..... | 8A 2.05, 16a 2.45. | 4 50 | <i>Hartshorn</i> |
| 30..... | 6A 2.60, 10a 2.55. | 5 15 | <i>Hartwort</i> |
| 36..... | 5A 3.00, 8a 2.75. | 5 75 | <i>Haruspice</i> |
| 48..... | 4A 4.00, 6a 3.65. | 7 65 | <i>Harvest</i> |
| | | | <i>Harvestbug</i> |

Gothic No. 125. £

| | | | |
|-----------|---------------------|------|-------------------|
| 6 Pt..... | 32A 1.15, 64a 1.30. | 2 45 | <i>Harvestfly</i> |
| 8..... | 24A 1.05, 48a 1.25. | 2 30 | <i>Hashish</i> |
| 10..... | 24A 1.25, 48a 1.40. | 2 65 | <i>Haspicoll</i> |
| 12..... | 18A 1.20, 36a 1.30. | 2 50 | <i>Haslated</i> |
| 14..... | 16A 1.30, 32a 1.50. | 2 80 | <i>Hastened</i> |
| 18..... | 12A 1.75, 24a 2.05. | 3 80 | <i>Hastily</i> |
| | | | <i>Hatable</i> |

Gothic No. 125—Continued.

Table with 4 columns: size, price, size, price. Rows include 24 Pt., 30, 36, 42, 48 with various font sizes and prices.

Gothic No. 127. E

Table with 4 columns: size, price, size, price. Rows include 3 Pt. on 6 Pt., 4 1/2 on 6, 5 on 6, 6, 8, 10, 12, 16, 18, 20, 24, 30, 36, 42.

Gothic Slope No. 20. A

Table with 4 columns: size, price, size, price. Rows include 6 Pt., 8, 10, 12, 18, 24 with various font sizes and prices.

Gothic Wide. D

Table with 4 columns: size, price, size, price. Rows include 3 1/2 Pt. on 6 Pt., 4 on 6, 5 on 6, 5 1/2 on 6, 6, 8, 10, 12, 16, 20, 24, 30, 36.

Gothic Wide No. 2. D

Table with 4 columns: size, price, size, price. Rows include 6 Pt., 8, 10, 12, 16, 20, 24 with various font sizes and prices.

Graphic. A

Table with 4 columns: size, price, size, price. Rows include 18 Pt., 22, 24, 30 with various font sizes and prices.

Greek. C

Table with 4 columns: size, price, size, price. Rows include 6 Pt. No. 2, 7, 8, 10, 11, 12 with various font sizes and prices.

Grimaldi. F

Table with 4 columns: size, price, size, price. Rows include 18 Pt., 24 with various font sizes and prices.

Grolier. C

Table with 4 columns: size, price, size, price. Rows include 12 Pt., 18, 24 with various font sizes and prices.

Gutenberg. C

Table with 4 columns: size, price, size, price. Rows include 12 Pt., 18, 24 with various font sizes and prices.

Hades. F

Table with 4 columns: size, price, size, price. Rows include 24 Pt., 36, 48, 60 with various font sizes and prices.

Half-Nonpareil Borders. D

Table with 4 columns: No., size, price, size, price. Rows include No. 1, 2, 5, 6, 10, 14, 17, 20, 21, 22, 24, 25, 27, 28, 29, 30, 31, 32, 33, 34, 35, 37, 38, 40, 42, 44, 45.

Half Title Nos. 120 and 122. E

Table with 4 columns: size, price, size, price. Rows include 6 Pt. No. 120, 8, 8, 10, 11, 12, 14, 16.

Halftone. E

Table with 4 columns: size, price, size, price. Rows include 18 Pt., 24, 36 with various font sizes and prices.

Hamburg. B

Table with 4 columns: size, price, size, price. Rows include 6 Pt., 8, 10, 12, 14, 18, 22, 24, 30 with various font sizes and prices.

Hansard. C

Table with 4 columns: size, price, size, price. Rows include 6 Pt., 9, 12, 18, 24 with various font sizes and prices.

Hapgood Florets. A

Table with 4 columns: size, price, size, price. Row includes 48 Pt. with various font sizes and prices.

HAPGOOD INITIALS (see Initials).

Happy Thoughts. A

Table with 4 columns: Group, size, price, size, price. Rows include Group E, F, G, H, K, L with various font sizes and prices.

Harper. F

Table with 4 columns: size, price, size, price. Rows include 12 Pt., 18, 24, 36, 48 with various font sizes and prices.

Harvard Italic. A

Table with 4 columns: size, price, size, price. Rows include 6 Pt., 8, 9, 10, 12, 14, 18, 24, 30 with various font sizes and prices.

Heavyface Greek. A

| | | | |
|-----------|-----------|-----------|----------------|
| 8 Pt..... | Job font, | \$7 50... | <i>Icemen</i> |
| 11..... | | 7 50... | <i>Icepick</i> |

Hebrew No. 1. B

| | | | |
|-----------|-----------|---------|-------------------|
| 6 Pt..... | Job font, | 3 60... | <i>Icicle</i> |
| 8..... | | 3 60... | <i>Iciness</i> |
| 9..... | | 3 60... | <i>Iconism</i> |
| 10..... | | 3 60... | <i>Iconizing</i> |
| 12..... | | 3 00... | <i>Iconoclasm</i> |
| 18..... | | 4 00... | <i>Iconolater</i> |
| 24..... | | 3 00... | <i>Icosandria</i> |
| 28..... | | 3 75... | <i>Icteria</i> |

HEBREW VOWEL ACCENTS.

| | | | |
|-----------|----------|---------|------------------|
| 4 Pt..... | per lb., | 3 80... | <i>Icterical</i> |
| 5..... | | 3 60... | <i>Icterious</i> |
| 6..... | | 2 50... | <i>Icteroïd</i> |
| 8..... | | 2 40... | <i>Idalian</i> |

Hebrew No. 2. B

| | | | |
|-----------|-----------|---------|-------------------|
| 8 Pt..... | Job font, | 2 25... | <i>Ideatless</i> |
| 10..... | | 2 25... | <i>Ideatistic</i> |
| 12..... | | 2 50... | <i>Ideality</i> |
| 18..... | | 2 50... | <i>Ideatize</i> |
| 24..... | | 3 00... | <i>Ideologue</i> |

Heintzemann. B

| | | | | |
|-----------|-------------|--------------|---------|-------------------|
| 6 Pt..... | 15A \$0.90, | 50a \$1.25.. | 2 15... | <i>Idolatrous</i> |
| 8..... | 15A 1.15, | 50a 1.45.. | 2 60... | <i>Idolatry</i> |
| 9..... | 12A 1.00, | 50a 1.60.. | 2 60... | <i>Idolism</i> |
| 10..... | 12A 1.30, | 40a 1.55.. | 2 85... | <i>Idolized</i> |
| 12..... | 12A 1.55, | 40a 1.80.. | 3 35... | <i>Idolizing</i> |
| 14..... | 12A 2.15, | 40a 2.65.. | 4 80... | <i>Idoloelast</i> |
| 18..... | 10A 2.15, | 30a 2.80.. | 4 95... | <i>Idrialine</i> |
| 24..... | 8A 2.80, | 25a 3.00.. | 5 80... | <i>Idyllic</i> |
| 30..... | 6A 3.45, | 20a 3.65.. | 7 10... | <i>Igasuric</i> |

Hermes. F

| | | | | |
|------------|-----------|------------|---------|---------------------|
| 12 Pt..... | 18A 1.70, | 24a 1.30.. | 3 00... | <i>Ill-looking</i> |
| 18..... | 12A 1.75, | 18a 1.50.. | 3 25... | <i>Illogicality</i> |
| 24..... | 10A 2.50, | 15a 2.00.. | 4 50... | <i>Illogical</i> |
| 36..... | 6A 2.85, | 10a 2.65.. | 5 50... | <i>Illomened</i> |

Herriet Script. B

| | | | | |
|------------|-----------|-------------|----------|-------------------|
| 12 Pt..... | 12A 4.50, | 50a 4.50.. | 9 00... | <i>Imagined</i> |
| | 8A 3.00, | 30a 3.00.. | 6 00... | <i>Imagining</i> |
| | 4A 1.50, | 15a 1.50.. | 3 00... | <i>Imacums</i> |
| 18..... | 12A 5.00, | 50a 7.00.. | 12 00... | <i>Imbecile</i> |
| | 8A 3.40, | 20a 2.80.. | 6 20... | <i>Imbecility</i> |
| | 4A 1.70, | 10a 1.40.. | 3 10... | <i>Imbedded</i> |
| 24..... | 12A 7.10, | 50a 10.00.. | 17 10... | <i>Imbedding</i> |
| | 8A 5.00, | 20a 4.00.. | 9 00... | <i>Imbellic</i> |
| | 4A 2.40, | 10a 2.10.. | 4 50... | <i>Imbenching</i> |

Hoboes. F

| | | |
|---------------|---------|---------------|
| Per font..... | 1 50... | <i>Imbibe</i> |
|---------------|---------|---------------|

Holly Border. F

| | | | |
|------------|-----------------|---------|-------------------|
| No. 1..... | per font, | 3 00... | <i>Imbibers</i> |
| 2..... | For two colors, | 3 00... | <i>Imbibing</i> |
| 3..... | Red and Green | 3 00... | <i>Imbibition</i> |

Houghton. C

| | | | | |
|------------|----------|------------|----------|-------------------|
| 24 Pt..... | 4A 2.25, | 10a 2.25.. | 4 50... | <i>Impiously</i> |
| 36..... | 3A 4.40, | 7a 3.10.. | 7 50... | <i>Impish</i> |
| 48..... | 3A 6.00, | 5a 3.25.. | 9 25... | <i>Impishly</i> |
| 60..... | 3A 7.90, | 4a 4.00.. | 11 90... | <i>Implacable</i> |

Howland. A

| | | | | |
|-----------|-----------|------------|----------|--------------------|
| 6 Pt..... | 30A 1.25, | 50a 1.00.. | 2 25... | <i>Imploreth</i> |
| 8..... | 28A 1.50, | 40a 1.00.. | 2 50... | <i>Imploring</i> |
| 10..... | 24A 1.50, | 36a 1.25.. | 2 75... | <i>Imploringly</i> |
| 12..... | 20A 1.70, | 30a 1.30.. | 3 00... | <i>Implumed</i> |
| 18..... | 12A 1.75, | 20a 1.50.. | 3 25... | <i>Implumous</i> |
| 24..... | 10A 2.25, | 16a 1.75.. | 4 00... | <i>Implunges</i> |
| 30..... | 8A 2.75, | 12a 2.25.. | 5 00... | <i>Implunging</i> |
| 42..... | 6A 3.25, | 10a 2.75.. | 6 00... | <i>Implying</i> |
| 48..... | 5A 3.75, | 8a 3.25.. | 7 00... | <i>Impocket</i> |
| 54..... | 4A 4.50, | 6a 3.50.. | 8 00... | <i>Impoisoner</i> |
| 60..... | 4A 5.61, | 5a 3.39.. | 9 00... | <i>Impolicy</i> |
| 72..... | 4A 7.40, | 5a 4.60.. | 12 00... | <i>Impolitely</i> |
| 96..... | 4A 9.40, | 5a 5.60.. | 15 00... | <i>Impolitice</i> |
| 120..... | 3A 12.00, | 4a 7.00.. | 19 00... | <i>Imponed</i> |

Howland Open. A

| | | | | |
|------------|-----------|------------|---------|-------------------|
| 10 Pt..... | 24A 1.50, | 36a 1.25.. | 2 75... | <i>Impound</i> |
| 12..... | 20A 1.70, | 30a 1.30.. | 3 00... | <i>Impoundage</i> |
| 18..... | 12A 2.00, | 20a 1.75.. | 3 75... | <i>Impounders</i> |

Howland Open—Continued.

| | | | | |
|------------|-------------|--------------|-----------|-------------------|
| 24 Pt..... | 10A \$2.50, | 16a \$2.00.. | \$4 50... | <i>Impounding</i> |
| 30..... | 8A 3.00, | 12a 2.50.. | 5 50... | <i>Impoverish</i> |
| 42..... | 6A 3.50, | 10a 3.00.. | 6 50... | <i>Imprecate</i> |
| 48..... | 5A 4.00, | 8a 3.50.. | 7 50... | <i>Impregmant</i> |
| 54..... | 4A 4.50, | 6a 4.00.. | 8 50... | <i>Impresa</i> |
| 60..... | 4A 5.25, | 5a 4.25.. | 9 50... | <i>Impressed</i> |

Ihlenburg. C

| | | | | |
|-----------|-----------|------------|---------|----------------------|
| 6 Pt..... | 20A 1.00, | 60a 1.40.. | 2 40... | <i>Incasked</i> |
| 8..... | 18A 1.05, | 52a 1.65.. | 2 70... | <i>Incaskellated</i> |
| 10..... | 16A 1.10, | 50a 1.90.. | 3 00... | <i>Incaskelled</i> |
| 12..... | 15A 1.25, | 45a 2.00.. | 3 25... | <i>Incatenation</i> |
| 18..... | 8A 1.35, | 25a 2.20.. | 3 55... | <i>Incautious</i> |
| 24..... | 5A 1.40, | 16a 2.40.. | 3 80... | <i>Incavution</i> |
| 36..... | 4A 2.30, | 10a 3.10.. | 5 40... | <i>Incavutious</i> |
| 48..... | 3A 3.25, | 8a 4.10.. | 7 35... | <i>Incavutiously</i> |
| 60..... | 3A 4.95, | 5a 4.70.. | 9 65... | <i>Incavutied</i> |

Ihlenburg Extended. C

| | | | | |
|-----------|-----------|------------|----------|---------------------|
| 6 Pt..... | 20A 1.20, | 60a 2.00.. | 3 20... | <i>Incaved</i> |
| 8..... | 16A 1.25, | 50a 2.25.. | 3 50... | <i>Incavern</i> |
| 10..... | 16A 1.35, | 48a 2.40.. | 3 75... | <i>Incaverned</i> |
| 12..... | 14A 1.60, | 42a 2.70.. | 4 30... | <i>Incavo</i> |
| 15..... | 12A 1.85, | 36a 3.00.. | 4 85... | <i>Incade</i> |
| 18..... | 10A 2.05, | 28a 3.30.. | 5 35... | <i>Incadingly</i> |
| 24..... | 6A 2.45, | 16a 3.40.. | 5 85... | <i>Inccelebrity</i> |
| 30..... | 5A 2.70, | 12a 3.75.. | 6 45... | <i>Incend</i> |
| 36..... | 4A 2.80, | 10a 4.20.. | 7 00... | <i>Incendiarism</i> |
| 48..... | 3A 4.35, | 6a 4.80.. | 9 15... | <i>Incendriary</i> |
| 60..... | 3A 6.25, | 4a 4.95.. | 11 20... | <i>Incendious</i> |

Imprint Gothic. E-F

| | | | |
|--------------------|----------------|-------|-------------------|
| 6 Pt. No. 121..... | 32A..... | 75... | <i>Incubation</i> |
| 6..... | 124...28A..... | 65... | <i>Incubatory</i> |
| 6..... | 150...48A..... | 75... | <i>Incube</i> |

Inclined Antique. B

| | | | | |
|-----------|-----------|------------|---------|-------------------|
| 6 Pt..... | 30A 1.45, | 50a 1.30.. | 2 75... | <i>Indefinite</i> |
| 8..... | 30A 1.80, | 50a 1.35.. | 3 15... | <i>Indelibly</i> |
| 10..... | 25A 1.85, | 40a 1.50.. | 3 35... | <i>Indelicacy</i> |
| 12..... | 20A 2.00, | 30a 1.50.. | 3 50... | <i>Indemnify</i> |

Inclined Gothic. A-F

| | | | |
|------------------|--------------|---------|-------------------|
| 6 Pt. No. 4..... | 34A..... | 1 25... | <i>Indirect</i> |
| 6..... | 5...32A..... | 1 25... | <i>Indirectly</i> |
| 6..... | 6...30A..... | 1 25... | <i>Indiscreet</i> |
| 6..... | 7...28A..... | 1 25... | <i>Indisposed</i> |
| 8..... | 26A..... | 1 50... | <i>Indistancy</i> |
| 10..... | 24A..... | 1 75... | <i>Indistinct</i> |
| 12..... | 20A..... | 2 00... | <i>Inditched</i> |
| 16..... | 14A..... | 2 25... | <i>Inditeth</i> |
| 18..... | 12A..... | 2 50... | <i>Individual</i> |
| 24..... | 8A..... | 3 00... | <i>Indivinity</i> |

INDEX INITIALS (see Initials).

Inferior Figures. C-F

| | | | | |
|------------|----------|---------|---------|-------------------|
| 5½ Pt..... | 40..... | per lb. | 2 40... | <i>Inerrancy</i> |
| 6..... | 150..... | | 2 00... | <i>Inerratic</i> |
| 7..... | 150..... | | 1 80... | <i>Inertia</i> |
| 8..... | 150..... | | 1 60... | <i>Inertly</i> |
| 9..... | 150..... | | 1 44... | <i>Inerudite</i> |
| 10..... | 150..... | | 1 30... | <i>Inescate</i> |
| 11..... | 150..... | | 1 22... | <i>Inescation</i> |
| 12..... | 150..... | | 1 16... | <i>Inevisable</i> |

Inferior Letters. C-F

| | | | | |
|------------|----------|---------|---------|---------------------|
| 5½ Pt..... | 40..... | per lb. | 2 40... | <i>Inevilent</i> |
| 6..... | 150..... | | 2 00... | <i>Inevitable</i> |
| 7..... | 150..... | | 1 80... | <i>Inexact</i> |
| 8..... | 150..... | | 1 60... | <i>Incentration</i> |
| 9..... | 150..... | | 1 44... | <i>Inexistent</i> |
| 10..... | 150..... | | 1 30... | <i>Inexpert</i> |
| 11..... | 150..... | | 1 22... | <i>Inexpitably</i> |
| 12..... | 150..... | | 1 16... | <i>Inexpiate</i> |

Initials. (Cast in Mould.)

| | | | |
|-------------|----------|---------|-------------------|
| ART SERIES. | | | |
| 48 Pt..... | per set, | 3 00... | <i>Infernal</i> |
| 72..... | | 4 00... | <i>Inferrible</i> |

BRADLEY (see Bradley Initials).

COLUMBUS (see Columbus Initials).

COLUMBUS OUTLINE (see Columbus Outline Initials).

EMPIRE (see Empire Initials).

HAPGOOD SERIES.

| | | | | | |
|------------|-------|----------|----------|----------|------------------|
| No. 1..... | each, | .50... | per set, | 10 00... | <i>Infertile</i> |
| 2..... | | .50..... | | 10 00... | <i>Infest</i> |

Initials. (Cast in Mould)—Continued.

IPSEN SERIES.
 No. 1...48 Pt. each, \$0.40...per set, \$6 00...*Infestation*
 No. 2...36.....30.....4 00...*Infester*

JENSON SERIES.
 No. 79...72 Pt. each, .60.....*Infestive*
 No. 80...48.....50.....*Infestuous*
 No. 82...30.....25.....*Infestation*

MORRIS SERIES.
 No. 76.....each, .75.....15 00...*Infidel*
 No. 77......60.....12 00...*Infidelity*
 No. 78......50.....10 00...*Infilded*

MORTISED SERIES.
 No. 2...48 Pt.....3A.....6 00...*Infilmed*

SCHOEFFER (see Schœffer Initials).

SERIES No.
 320, ornam. each, .35...per set, 5 00...*Infiltrate*
 320, plain......35.....3 50...*Infinite*
 321, ornam......50.....7 50...*Infinately*
 321, plain......50.....6 00...*Infinite*
 440......40.....5 00...*Infinite*
 441......40.....7 00...*Infirm*
 1132......40.....3 50...*Infirmity*
 1133......40.....3 50...*Infirmity*
 1136......40.....2 00...*Infirming*
 1142......40.....2 00...*Inflatus*

SERIES No.
 1143.....per set, 3 50...*Inflections*
 1146.....each, .20.....1 75...*Inflexible*
 1147......25.....2 25...*Inflexure*
 1148......30.....3 50...*Influct*
 1155......40.....3 50...*Influcteth*

TENDRIL.
 No. 1...60 Pt. each, .50...per set, 8 00...*Influctive*
 No. 2...48......40.....6 00...*Inflow*

TWO-COLOR SERIES.
 No. 50.....for two, .40...set of 52 3 50...*Influences*
 No. 51......50.....4 50...*Influent*
 No. 52......60.....7 00...*Influenza*

WAYSIDE SERIES.
 No. 1.....each, .60...set of 51, 22 50...*Influencing*
 No. 2......60.....22 50...*Influx*

Initials. (Electrotyped.)

ACORN SERIES.
 No. 71.....each, .60...per set, 12 00...*Inimical*
 No. 72......50.....11 00...*Inimicality*
 No. 73......40.....9 00...*Inimicous*

FIFTH.
 No. 50.....each, .50...per set, 10 00...*Inimitably*

INDEX SERIES.
 No. 50.....each, .50...per set, 10 00...*Iniome*
 No. 51......40.....8 00...*Inionomous*

LENTEN.
 No. 50.....each, .40...per set, 9 00...*Iniquity*
 No. 51......35.....8 00...*Inirritable*

MISSAL.
 No. 57.....each, .35.....*Inirritative*
 No. 58......40.....*Inisted*

MULTIPLE.
 No. 52.....each, .40.....9 00...*Initially*
 No. 53......50...per set, 10 00...*Initiated*

NEPTUNE.
 No. 65.....each, .40...per set, 9 00...*Initiation*
 No. 66......35.....8 00...*Initiative*

NONAME.
 No. 59.....each, .40...series, 9 00...*Initiatrix*
 No. 60......35.....8 00...*Inition*

RENATE SERIES.
 No. 69.....each, .40...per set, 9 00...*Injctious*
 No. 70......35.....8 00...*Injected*

SERIES No.
 421.....each, .35...per set, 7 00...*Injection*
 424......25.....5 00...*Injectional*
 425......30.....6 00...*Injective*
 426......35.....7 00...*Injectors*
 442......50.....10 00...*Injudicious*
 1158......50.....6 00...*Injunction*
 1159......40.....4 50...*Injured*

WAVERLEY SERIES.
 No. 74.....each, .40.....*Injurious*
 No. 75......50.....*Injury*

Ink Spots. E

Per font.....\$1 25...*Injustice*
INLAND SERIES No. 56 (sold at Roman prices).

Inscription Greek. B

10 Pt.....30A.....4 80...*Injustifiable*

Interchangeable Gothic. E *Inkiness*

6 Pt. No. 1.....36A.....90...*Inkling*
 6.....2.....36A.....1 05...*Inknits*
 6.....3.....36A.....1 25...*Inknitted*
 6.....4.....36A.....1 45...*Inknob*
 6.....5.....36A.....1 70...*Inknobbed*
 8.....24A.....1 35...*Inkstand*
 10.....18A.....1 35...*Inkstone*
 12.....18A.....2 00...*Inlandish*
 18.....12A.....2 30...*Inlapidate*
 20.....8A.....2 50...*Inlaying*
 24.....6A.....2 45...*Inleagued*
 32.....4A.....3 00...*Inlets*
 36.....4A.....3 90...*Inmates*
 48.....3A.....5 90...*Inmewed*

Ionic No. 30. B

*48 Pt.....4A \$5.25, 6a \$3.65.. 8 90...*Instructor*

Ionic No. 120. E

5½ Pt.....24A 1.20, 48a 1.35.. 2 55...*Instructs*
 6.....24A 1.20, 48a 1.30.. 2 50...*Instrument*
 8.....24A 1.50, 48a 1.60.. 3 10...*Instyle*
 10.....18A 1.45, 36a 1.60.. 3 05...*Insuavity*
 12.....18A 1.75, 36a 1.90.. 3 65...*Insuetude*
 18.....16A 2.25, 32a 2.65.. 4 90...*Insular*
 24.....10A 2.65, 20a 3.00.. 5 65...*Insularity*
 36.....6A 3.60, 12a 4.10.. 7 70...*Insulated*

Ionic No. 122. E

5 Pt.....24A 1.20, 48a 1.40.. 2 60...*Insulous*
 6.....24A 1.05, 48a 1.25.. 2 30...*Insult*
 8.....24A 1.20, 48a 1.40.. 2 60...*Insulteth*
 10.....18A 1.20, 36a 1.40.. 2 60...*Insulting*
 12.....16A 1.40, 32a 1.75.. 3 15...*Insurancer*
 18.....10A 1.80, 20a 1.90.. 3 70...*Insurgency*
 24.....8A 2.15, 16a 2.55.. 4 70...*Insurgent*
 30.....6A 2.30, 12a 2.60.. 4 90...*Inswathed*
 36.....4A 2.50, 8a 2.70.. 5 20...*Intact*
 42.....3A 3.55, 6a 3.60.. 7 15...*Intactible*
 48.....3A 5.50, 6a 4.75.. 10 25...*Intaglio*

Ionic No. 150. F

6 Pt.....30A 1.25, 45a 1.00.. 2 25...*Intastable*
 8.....24A 1.30, 36a 1.20.. 2 50...*Integer*
 10.....22A 1.50, 32a 1.25.. 2 75...*Integral*
 12.....17A 1.60, 28a 1.40.. 3 00...*Integrally*
 20.....10A 1.75, 16a 1.75.. 3 50...*Integrant*
 24.....7A 2.00, 11a 2.00.. 4 00...*Integrates*
 36.....6A 2.80, 10a 2.20.. 5 00...*Integrity*
 42.....5A 3.60, 6a 2.40.. 6 00...*Integument*
 48.....3A 4.00, 5a 3.00.. 7 00...*Intellect*

Ionic No. 159. F

42 Pt.....4A 3.80, 5a 2.60.. 6 40...*Intake*

Ipsen Borders. A

12 Pt. No. 135.....36 inches, 1 50...*Intimately*
 12.....136.....36.....1 50...*Intimation*
 12.....137.....36.....1 50...*Intimidate*
 18.....130.....30.....1 50...*Intituled*
 18.....131.....30.....1 50...*Intolerant*
 18.....132.....30.....1 50...*Intonated*
 18.....133.....30.....1 50...*Intonating*
 24.....134.....20.....1 50...*Intonation*

IPSEN INITIALS (see Initials).

Iroquois. F

6 Pt.....20A 1.05, 40a 1.35.. 2 40...*Intoning*
 8.....15A .90, 30a 1.20.. 2 10...*Intorsion*
 10.....14A 1.10, 20a 1.25.. 2 35...*Intorts*
 12.....10A 1.10, 18a 1.30.. 2 40...*Intoxicant*
 18.....6A 1.55, 12a 1.75.. 3 30...*Intoxicate*
 24.....5A 2.10, 10a 2.40.. 4 50...*Intractad*
 30.....4A 2.65, 8a 2.85.. 5 50...*Intractile*
 36.....3A 3.25, 6a 3.25.. 6 50...*Intrados*
 48.....3A 4.50, 4a 3.50.. 8 00...*Intragyal*
 60.....3A 7.00, 4a 5.00.. 12 00...*Intramural*

Iroquois Condensed. F *Intranasal*

| | | | | | | |
|-----------|-----|---------|-----|---------|-----------|--------------------|
| 6 Pt..... | 25A | \$1.00, | 35a | \$1.00. | \$2 00... | <i>Intransient</i> |
| 8..... | 20A | 1.20, | 30a | 1.05. | 2 25... | <i>Intrant</i> |
| 10..... | 15A | 1.35, | 25a | 1.15. | 2 50... | <i>Intrinch</i> |
| 12..... | 12A | 1.50, | 20a | 1.25. | 2 75... | <i>Intrinchel</i> |
| 18..... | 10A | 1.50, | 16a | 1.50. | 3 00... | <i>Intrrepid</i> |
| 24..... | 8A | 1.95, | 12a | 1.80. | 3 75... | <i>Intrrepidty</i> |
| 30..... | 6A | 2.20, | 9a | 2.05. | 4 25... | <i>Intricity</i> |
| 36..... | 5A | 2.55, | 8a | 2.35. | 4 90... | <i>Intricate</i> |
| 48..... | 4A | 3.50, | 6a | 3.00. | 6 50... | <i>Intrigue</i> |
| 60..... | 3A | 5.00, | 5a | 4.00. | 9 00... | <i>Intriguers</i> |

Isabella. c *Intriguing*

| | | | | | | |
|-----------|-----|-------|-----|-------|---------|-------------------|
| 9 Pt..... | 10A | 1.45, | 35a | 2.00. | 3 45... | <i>Intriguing</i> |
| 12..... | 8A | 1.50, | 32a | 2.30. | 3 80... | <i>Introduce</i> |
| 18..... | 5A | 1.70, | 20a | 2.45. | 4 15... | <i>Intromit</i> |

Ivanhoe. e *Isinglass*

| | | | | | | |
|-----------|-----|-------|------|-------|----------|-------------------|
| 8 Pt..... | 36A | 3.00, | 150a | 7.75. | 10 75... | <i>Islamism</i> |
| | 12A | 1.20, | 20a | 1.20. | 2 40... | <i>Islamic</i> |
| 10..... | 30A | 3.15, | 140a | 8.70. | 11 85... | <i>Islamized</i> |
| | 10A | 1.15, | 18a | 1.20. | 2 35... | <i>Islamizing</i> |
| 12..... | 25A | 2.95, | 125a | 8.80. | 11 75... | <i>Islanders</i> |
| | 10A | 1.20, | 16a | 1.20. | 2 40... | <i>Islands</i> |
| 18..... | 8A | 2.00, | 12a | 1.75. | 3 75... | <i>Isobase</i> |
| 24..... | 6A | 2.35, | 10a | 2.40. | 4 75... | <i>Isoheim</i> |
| 30..... | 4A | 2.90, | 6a | 2.35. | 5 25... | <i>Isochimtal</i> |
| 36..... | 4A | 3.30, | 5a | 2.20. | 5 50... | <i>Isochimene</i> |

Jagged. A *Jackdaw*

| | | | |
|---------------|-----|---------|------------------|
| 12 Pt. No. 39 | 12A | 1 75... | <i>Jacketed</i> |
| 12..... | 40 | 1 75... | <i>Jackflag</i> |
| 12..... | 41 | 1 75... | <i>Jackfruit</i> |

Jefferson. F *Jalousies*

| | | | | | | |
|-----------|-----|-------|-----|-------|----------|-------------------|
| 6 Pt..... | 26A | 1.15, | 38a | 1.10. | 2 25... | <i>Jamacina</i> |
| 8..... | 24A | 1.30, | 32a | 1.20. | 2 50... | <i>Jambeux</i> |
| 10..... | 20A | 1.40, | 28a | 1.35. | 2 75... | <i>Jamdart</i> |
| 12..... | 16A | 1.50, | 24a | 1.50. | 3 00... | <i>Jamesonite</i> |
| 18..... | 10A | 1.75, | 14a | 1.50. | 3 25... | <i>Jamnut</i> |
| 24..... | 8A | 2.50, | 10a | 2.00. | 4 50... | <i>Jangada</i> |
| 30..... | 6A | 2.50, | 8a | 2.25. | 4 75... | <i>Jangleress</i> |
| 36..... | 5A | 2.90, | 7a | 2.85. | 5 75... | <i>Janissary</i> |
| 42..... | 4A | 3.25, | 6a | 3.00. | 6 25... | <i>Janitor</i> |
| 48..... | 4A | 4.00, | 6a | 3.75. | 7 75... | <i>Janitrix</i> |
| 54..... | 4A | 5.00, | 5a | 3.50. | 8 50... | <i>Janizar</i> |
| 60..... | 4A | 6.25, | 5a | 4.75. | 11 00... | <i>Janizarian</i> |

Jenson Embellishments. A

| | |
|----------|---------|
| No. 4245 | 1 00... |
| 4249 | 1 00... |
| 4257 | 75... |
| 4258 | 1 00... |
| 4259 | 1 00... |
| 4261 | 1 00... |
| 4264 | 2 00... |
| 4268 | 2 00... |
| 4276 | 75... |
| 4277 | 1 25... |
| 4278 | 75... |
| 4288 | 1 25... |
| 4294 | 75... |
| 4295 | 1 00... |
| 4431 | 75... |
| 4432 | 75... |
| 4433 | 50... |
| 4434 | 1 00... |
| 4435 | 75... |
| 4436 | 75... |
| 4437 | 1 00... |
| 4438 | 75... |
| 4439 | 1 00... |
| 4440 | 1 75... |

Jenson Heavyface. A *Janthina*

| | | | | | | |
|------------|-----|--------|-----|-------|----------|-------------------|
| 12 Pt..... | 18A | 1.85, | 30a | 1.40. | 3 25... | <i>Jantily</i> |
| 18..... | 12A | 2.30, | 20a | 1.70. | 4 00... | <i>Janusfaect</i> |
| 24..... | 10A | 2.70, | 15a | 1.80. | 4 50... | <i>Japanned</i> |
| 30..... | 6A | 2.75, | 10a | 2.25. | 5 00... | <i>Japanning</i> |
| 36..... | 5A | 3.20, | 8a | 2.30. | 5 50... | <i>Japannish</i> |
| 48..... | 4A | 5.00, | 5a | 2.75. | 7 75... | <i>Japheta</i> |
| 60..... | 4A | 7.85, | 5a | 4.40. | 12 25... | <i>Jargogle</i> |
| 72..... | 4A | 11.00, | 5a | 6.00. | 17 00... | <i>Jargon</i> |
| 96..... | 3A | 12.50, | 4a | 6.50. | 19 00... | <i>Jargonette</i> |
| 120..... | 3A | 14.80, | 4a | 7.70. | 22 50... | <i>Jargonie</i> |

JENSON INITIALS (see Initials).

Jenson Italic. B *Jasperite*

| | | | | | | |
|-----------|-----|---------|-----|---------|-----------|------------------|
| 6 Pt..... | 20A | \$1.20, | 50a | \$1.30. | \$2 50... | <i>Jasponial</i> |
| 8..... | 20A | 1.40, | 50a | 1.35. | 2 75... | <i>Jasponyx</i> |
| 10..... | 20A | 1.60, | 45a | 1.40. | 3 00... | <i>Jatrophia</i> |
| 12..... | 18A | 1.70, | 40a | 1.55. | 3 25... | <i>Jatrophic</i> |
| 18..... | 10A | 2.00, | 25a | 2.00. | 4 00... | <i>Jaundiced</i> |
| 24..... | 6A | 2.15, | 15a | 2.35. | 4 50... | <i>Jauntness</i> |
| 30..... | 5A | 2.40, | 10a | 2.60. | 5 00... | <i>Jaunty</i> |
| 36..... | 4A | 2.80, | 8a | 2.70. | 5 50... | <i>Jauntycar</i> |
| 42..... | 4A | 4.00, | 6a | 3.25. | 7 25... | <i>Javelin</i> |
| 48..... | 4A | 4.50, | 5a | 3.25. | 7 75... | <i>Jacobone</i> |
| 54..... | 4A | 6.00, | 5a | 4.25. | 10 25... | <i>Jawfulen</i> |
| 60..... | 4A | 8.00, | 5a | 4.25. | 12 25... | <i>Jawtooth</i> |
| 72..... | 4A | 9.00, | 5a | 8.00. | 17 00... | <i>Jawzrant</i> |

Jenson Old Style. A *Jealousy*

| | | | | | | |
|-----------|-----|--------|-----|-------|----------|-------------------|
| 6 Pt..... | 35A | 1.50, | 50a | 1.00. | 2 50... | <i>Jeannette</i> |
| 8..... | 25A | 1.50, | 35a | 1.25. | 2 75... | <i>Jeered</i> |
| 10..... | 25A | 1.75, | 30a | 1.25. | 3 00... | <i>Jeering</i> |
| 12..... | 18A | 1.85, | 30a | 1.40. | 3 25... | <i>Jeeringty</i> |
| 14..... | 15A | 1.95, | 25a | 1.55. | 3 50... | <i>Jegged</i> |
| 18..... | 12A | 2.20, | 20a | 1.80. | 4 00... | <i>Jehovist</i> |
| 24..... | 10A | 2.60, | 15a | 1.90. | 4 50... | <i>Jejune</i> |
| 30..... | 6A | 2.90, | 10a | 2.10. | 5 00... | <i>Jellied</i> |
| 36..... | 5A | 3.00, | 8a | 2.50. | 5 50... | <i>Jellybag</i> |
| 42..... | 4A | 4.00, | 6a | 3.25. | 7 25... | <i>Jellyfish</i> |
| 48..... | 4A | 4.65, | 5a | 3.10. | 7 75... | <i>Jemidar</i> |
| 54..... | 4A | 6.00, | 5a | 4.25. | 10 25... | <i>Jennie</i> |
| 60..... | 4A | 7.25, | 5a | 5.00. | 12 25... | <i>Jeopardize</i> |
| 72..... | 4A | 10.00, | 5a | 7.00. | 17 00... | <i>Jeopardy</i> |

Job Commercial Signs. A

| | | | |
|------------|-----------|-------|------------------|
| 12 Pt..... | per font, | 50... | <i>Jerquer</i> |
| 18..... | | 50... | <i>Jersey</i> |
| 39..... | | 50... | <i>Jervina</i> |
| 36..... | | 50... | <i>Jessamine</i> |

Johnson. c *Jesters*

| | | | | | | |
|------------|----|-------|-----|-------|---------|-------------------|
| 18 Pt..... | 8A | 2.00, | 16a | 2.35. | 4 35... | <i>Jestful</i> |
| 24..... | 6A | 2.25, | 12a | 2.80. | 5 05... | <i>Jesting</i> |
| 30..... | 5A | 2.75, | 10a | 3.00. | 5 75... | <i>Jestingly</i> |
| 36..... | 4A | 3.05, | 8a | 3.15. | 6 20... | <i>Jesuit</i> |
| 48..... | 3A | 3.95, | 6a | 3.65. | 7 60... | <i>Jesuitess</i> |
| 60..... | 3A | 5.60, | 5a | 4.00. | 9 60... | <i>Jesuitical</i> |

Johnston Gothic. F *Jewels*

| | | | | | | |
|-----------|-----|-------|-----|-------|---------|-----------------|
| 6 Pt..... | 24A | 1.10, | 60a | 1.15. | 2 25... | <i>Jewsharp</i> |
| 8..... | 20A | 1.00, | 50a | 1.50. | 2 50... | <i>Jezebel</i> |
| 10..... | 18A | 1.40, | 45a | 1.60. | 3 00... | <i>Jibboom</i> |
| 12..... | 15A | 1.60, | 40a | 1.90. | 3 50... | <i>Jiggish</i> |
| 14..... | 14A | 1.50, | 36a | 2.25. | 3 75... | <i>Jiggog</i> |
| 16..... | 16A | 2.10, | 24a | 1.90. | 4 00... | <i>Jigpin</i> |

Jupiter. F *Jocose*

| | | | | | | |
|------------|-----|-------|-----|-------|---------|-------------------|
| 10 Pt..... | 16A | 1.40, | 40a | 1.60. | 3 00... | <i>Jocoseness</i> |
| 12..... | 16A | 1.65, | 26a | 1.35. | 3 00... | <i>Jocosity</i> |
| 18..... | 12A | 2.00, | 16a | 1.50. | 3 50... | <i>Jocular</i> |
| 24..... | 8A | 2.75, | 12a | 1.75. | 4 50... | <i>Jocularity</i> |
| 36..... | 6A | 3.65, | 9a | 2.10. | 5 75... | <i>Jocund</i> |
| 48..... | 4A | 4.60, | 6a | 2.40. | 7 00... | <i>Jocundity</i> |

Kate Greenaway Mignonettes. A

| | | |
|-------------------|-------|-------|
| Nos. 1 to 12..... | each, | 25... |
| 13 to 19..... | " | 30... |
| 20 to 42..... | " | 25... |
| 43 to 49..... | " | 30... |
| 50 to 60..... | " | 25... |

Kitcat. c *Kinships*

| | | | | | | |
|-----------|-----|-------|-----|-------|---------|------------------|
| 9 Pt..... | 12A | .70, | 16a | .55. | 1 25... | <i>Kinsman</i> |
| 12..... | 10A | .85, | 14a | .70. | 1 55... | <i>Kinswoman</i> |
| 18..... | 8A | 1.30, | 12a | 1.15. | 2 45... | <i>Kintal</i> |
| 24..... | 6A | 1.60, | 8a | 1.25. | 2 85... | <i>Kiosks</i> |
| 36..... | 4A | 2.50, | 5a | 1.65. | 4 15... | <i>Kipperced</i> |
| 48..... | 3A | 3.60, | 4a | 2.40. | 6 00... | <i>Kippering</i> |

Klondike Borders. D

| | | | |
|------------|------------|---------|-------------------|
| 12 Pt..... | 36 inches, | 1 75... | <i>Kippermut</i> |
| 18..... | 36..... | 2 00... | <i>Kippertime</i> |
| 36..... | 48..... | 4 00... | <i>Kipskins</i> |

Klondikers. E

| | | |
|----------------|---------|-----------------|
| Job font..... | 3 50... | <i>Kirkman</i> |
| Card font..... | 2 00... | <i>Kirkyard</i> |

Labor-Saving Brass Leaders. E

The words in the code-word column indicate the body and style of Leader, and are to be used with a code word for weight as given on page 1183.

STYLE No. 6.

| | |
|-------------------|-------------------|
| 5 Pt.....per lb., | \$1 60...Knockers |
| 5½..... | 1 60...Knocketh |
| 6..... | 1 60...Knocking |
| 7..... | 1 60...Knockneed |
| 8..... | 1 60...Knocks |
| 9..... | 1 50...Knockstone |
| 10..... | 1 50...Knolls |
| 11..... | 1 40...Knotberry |
| 12..... | 1 40...Knotgrass |

STYLE No. 7.

| | |
|-------------------|------------------|
| 5 Pt.....per lb., | 1 60...Knottless |
| 5½..... | 1 60...Knotted |
| 6..... | 1 60...Knotweed |
| 7..... | 1 60...Knotwort |
| 8..... | 1 60...Knowable |
| 9..... | 1 50...Knoweth |
| 10..... | 1 50...Knowing |
| 11..... | 1 40...Knowingly |
| 12..... | 1 40...Knowledge |

STYLE No. 8.

| | |
|-------------------|------------------|
| 5 Pt.....per lb., | 1 60...Knuckles |
| 5½..... | 1 60...Knuckling |
| 6..... | 1 60...Knurty |
| 7..... | 1 60...Kobellite |
| 8..... | 1 60...Kobold |
| 9..... | 1 50...Kohlrabi |
| 10..... | 1 50...Kolpoda |
| 11..... | 1 40...Konlrite |
| 12..... | 1 40...Kraken |

Labor-Saving Brass Rule. E

The words in the code-word column indicate the style of Rule only, and are to be used with a code word designating size of font wanted, as given below :

| | 2 lbs. | 3 lbs. | 5 lbs. | 10 lbs. | |
|---------------------|--------|--------|--------|---------|------------|
| No. 203E, 2 Pt..... | 3.50 | 5.25 | 8.25 | 16.50 | Labels |
|219E, 2..... | 3.50 | 5.25 | 8.25 | 16.50 | Labial |
|236E, 3..... | 3.20 | 4.80 | 7.50 | 15.00 | Labiated |
|237E, 4..... | 3.00 | 4.50 | 7.00 | 14.00 | Lablab |
|266E, 6..... | 3.00 | 4.50 | 7.00 | 14.00 | Laboratory |
|275E, 6..... | 3.00 | 4.50 | 7.00 | 14.00 | Laborers |
|281E, 3..... | 3.20 | 4.80 | 7.50 | 15.00 | Laboring |
|282E, 4..... | 3.00 | 4.50 | 7.00 | 14.00 | Laborious |
|284E, 6..... | 3.00 | 4.50 | 7.00 | 14.00 | Laborious |
|285E, 6..... | 3.00 | 4.50 | 7.00 | 14.00 | Labrax |
|287E, 8..... | | 4.50 | 7.00 | 14.00 | Labrose |
|288E, 10..... | | | 7.00 | 13.50 | Laburnum |
|292E, 4..... | 3.00 | 4.50 | 7.00 | 14.00 | Labyrinth |
|296E, 6..... | 3.00 | 4.50 | 7.00 | 14.00 | Lacebark |
|297E, 6..... | 3.00 | 4.50 | 7.00 | 14.00 | Laceboots |
|301E, 10..... | | | 7.00 | 13.50 | Laceman |
|340E, 2..... | 3.50 | 5.25 | 8.25 | 16.50 | Lacerable |
|341E, 2..... | 3.50 | 5.25 | 8.25 | 16.50 | Lacerated |

CODE WORDS FOR WEIGHT:

Each of the following words indicates the size of a font of Labor-Saving Brass Rule, and is to be used with a code word indicating style of Rule.

| | | |
|------------------|-------|-------------|
| 2-lb. font..... | | Lacertiform |
| 3 lb. font..... | | Lacertilia |
| 5-lb. font..... | | Lacertine |
| 10-lb. font..... | | Lacertoid |

LABOR-SAVING LEADS AND SLUGS (See Leads and Slugs).

LABOR-SAVING METAL FURNITURE (see Metal Furniture).

Labor-Saving Quotation Furniture.

| | |
|------------------|-------------------|
| 12 lb. font..... | 3 00...Ladyfinger |
| 25..... | 6 25...Ladyfish |
| 50..... | 12 50...Ladyfist |
| 100..... | 25 00...Ladyfuke |

Laclede. F

| | | |
|------------|------------------------|---------------------|
| 10 Pt..... | 9A \$1.15, 30a \$1.60. | \$2 75...Ladyhand |
| 12..... | 7A 1.15, 24a 1.85. | 3 00...Ladyhen |
| 18..... | 5A 1.25, 18a 2.00. | 3 25...Ladyhood |
| 24..... | 5A 1.85, 14a 2.15. | 4 00...Ladyhorse |
| 36..... | 4A 3.25, 9a 3.00. | 6 25...Ladykey |
| 48..... | 4A 4.50, 7a 3.50. | 8 00...Ladykiller |
| 60..... | 3A 5.50, 6a 4.50. | 10 00...Ladykilling |
| 72..... | 3A 7.50, 5a 4.50. | 12 00...Ladykin |

Ladyfly

Ladies' Hand Script. E

Laggards

| | | |
|------------|---------------------|--------------------|
| 18 Pt..... | 10A 3.45, 75a 5.55. | 9 00...Laggingly |
| | 6A 2.10, 16a 1.65. | 3 75...Lagomys |
| 24..... | 8A 4.45, 50a 6.45. | 10 90...Lagoons |
| | 4A 2.40, 12a 1.60. | 4 00...Lagopus |
| 32..... | 5A 4.55, 25a 5.45. | 10 00...Lagostomys |
| | 3A 2.65, 8a 1.85. | 4 50...Lagothrix |

Ladies' Hand Script No. 2. E

Lagune

| | | |
|------------|---------------------|------------------|
| 18 Pt..... | 10A 3.45, 75a 7.30. | 10 75...Laical |
| | 6A 2.10, 16a 1.65. | 3 75...Lakelets |
| 24..... | 8A 4.45, 50a 8.10. | 12 55...Lamaism |
| | 4A 2.40, 12a 2.10. | 4 50...Lamasery |
| 32..... | 5A 4.55, 25a 6.25. | 10 80...Lambale |
| | 3A 2.65, 8a 2.10. | 4 75...Lambative |

Lady Speakers. E

| | |
|---------------------|-------------------|
| Large.....per font, | 2 00...Lambdacism |
| Small..... | 1 25...Lambdoidal |

Lafayette. F

Lamplight

| | | |
|------------|---------------------|-------------------|
| 12 Pt..... | 20A 1.55, 30a 1.45. | 3 00...Lampoon |
| 18..... | 12A 1.75, 18a 1.50. | 3 25...Lampooners |
| 24..... | 10A 2.15, 14a 1.85. | 4 00...Lampooning |
| 30..... | 9A 2.65, 12a 2.35. | 5 00...Lampoonry |
| 36..... | 8A 3.25, 10a 2.50. | 5 75...Lampreys |
| 42..... | 6A 3.25, 9a 3.00. | 6 25...Lampyrine |
| 48..... | 6A 3.85, 8a 3.15. | 7 00...Lanated |
| 54..... | 4A 3.60, 6a 3.40. | 7 00...Lancegaye |
| 60..... | 4A 3.90, 6a 3.60. | 7 50...Lancehead |
| 72..... | 4A 5.50, 5a 4.00. | 9 50...Lancelet |

LARGE FACE SERIES No. 54 (sold at Roman prices).

Latin Antique No. 120. E

Larceny

| | | |
|----------------|---------------------|-------------------|
| 5 on 6 Pt..... | 24A 1.00, 48a 1.15. | 2 15...Larches |
| 6..... | 24A 1.15, 48a 1.45. | 2 60...Lardaceous |
| 8..... | 24A 1.40, 48a 1.60. | 3 00...Larders |
| 10..... | 18A 1.40, 36a 1.55. | 2 95...Lardie |
| 12..... | 12A 1.15, 24a 1.30. | 2 45...Lardry |
| 18..... | 10A 1.70, 20a 1.95. | 3 65...Largely |
| 24..... | 8A 2.10, 16a 2.40. | 4 50...Largeness |
| 30..... | 6A 2.45, 12a 2.90. | 5 35...Largest |
| 36..... | 4A 2.95, 8a 2.95. | 5 90...Larghetto |
| 48..... | 3A 4.35, 5a 3.35. | 7 70...Largifical |

Latin Compressed No. 30. B

Latched

| | | |
|------------|---------------------|-------------------|
| 12 Pt..... | 20A 1.10, 30a 1.05. | 2 15...Latchkey |
| 18..... | 15A 1.80, 20a 1.40. | 3 20...Lateensail |
| 24..... | 10A 2.00, 15a 1.75. | 3 75...Latency |
| 36..... | 8A 2.40, 12a 2.05. | 4 45...Lateral |
| 42..... | 8A 3.10, 12a 2.65. | 5 75...Laterality |
| 48..... | 6A 3.40, 10a 3.15. | 6 55...Laterites |

Latin Condensed No. 150. F

Laveur

| | | |
|------------|---------------------|--------------------|
| 10 Pt..... | 36A 1.50, 50a 1.25. | 2 75...Lavender |
| 12..... | 28A 1.65, 38a 1.35. | 3 00...Laverock |
| 18..... | 20A 1.75, 30a 1.50. | 3 25...Lavishly |
| 24..... | 15A 2.15, 20a 1.60. | 3 75...Lavolta |
| 30..... | 10A 2.25, 15a 1.75. | 4 00...Lawnbinding |
| 36..... | 8A 2.50, 12a 1.75. | 4 25...Lawnbooks |
| 48..... | 4A 2.75, 7a 2.25. | 5 00...Lawnbreaker |
| 60..... | 5A 4.60, 6a 2.90. | 7 50...Lawncaul |
| 72..... | 4A 4.50, 6a 4.00. | 8 50...Lawnful |

Latin Extended. F

Laxity

| | | |
|-----------|---------------------|-------------------|
| 6 Pt..... | 30A 2.05, 40a 1.85. | 3 90...Laxness |
| 8..... | 24A 2.05, 32a 1.70. | 3 75...Layerup |
| 10..... | 18A 1.95, 24a 1.65. | 3 60...Layland |
| 12..... | 12A 1.70, 20a 1.70. | 3 40...Laymen |
| 14..... | 10A 2.55, 14a 2.40. | 4 95...Layrace |
| 18..... | 8A 2.95, 12a 2.65. | 5 60...Laystall |
| 24..... | 6A 4.00, 8a 2.95. | 6 95...Lazaretto |
| 30..... | 4A 3.55, 6a 3.35. | 6 90...Lazarhouse |
| 36..... | 3A 4.70, 4a 3.95. | 8 65...Lazarists |

Laurel Borders. H

| | | |
|-------------------|----------|--------------------|
| 6 Pt..... | \$1 75.. | <i>Leeward</i> |
| 6.....No. 2..... | 1 75.. | <i>Leeway</i> |
| 12..... | 1 75.. | <i>Left-handed</i> |
| 12.....No. 2..... | 1 75.. | <i>Leftoff</i> |
| 18..... | 2 00.. | <i>Leftward</i> |
| 18.....No. 2..... | 2 00.. | <i>Legacy</i> |
| | | <i>Legutism</i> |

LAUREL ORNAMENTS (see Ornaments).

Laurel Wreaths. H

| | | |
|---------------------|------------|--------|
| Nos. 1 and 10..... | each, net, | 20.. |
| 2 and 11..... | | 30.. |
| 3 and 12..... | | 50.. |
| 4 and 13..... | | 50.. |
| 8 and 17..... | | 1 00.. |
| 9..... | | 1 25.. |
| 14..... | | 75.. |

Law Italic No. 12. c

| | | | |
|------------|-------------------------|--------|-------------------|
| 24 Pt..... | 8A \$1.60, 20a \$2.00.. | 3 60.. | <i>Legitimacy</i> |
| 30..... | 7A 2.05, 14a 2.45.. | 4 50.. | <i>Legitimate</i> |

Law Italic No. 120. E

| | | | |
|-----------|-----------------------|--------|-------------------|
| 6 Pt..... | 32A 1.30, 200a 5.40.. | 6 70.. | <i>Legitive</i> |
| | 16A .65, 50a 1.35.. | 2 00.. | <i>Legless</i> |
| 8..... | 32A 1.85, 200a 6.20.. | 8 05.. | <i>Legumes</i> |
| | 16A .95, 50a 1.55.. | 2 50.. | <i>Legumine</i> |
| 10..... | 24A 1.75, 140a 5.65.. | 7 40.. | <i>Leguminous</i> |
| | 12A .90, 35a 1.40.. | 2 30.. | <i>Lehantite</i> |
| 12..... | 18A 1.70, 100a 4.90.. | 6 60.. | <i>Leisurably</i> |
| | 9A .85, 25a 1.25.. | 2 10.. | <i>Leisure</i> |

Law Italic No. 122. E

| | | | |
|-----------|----------------------|--------|-------------------|
| 6 Pt..... | 25A 1.10, 70a 1.35.. | 2 45.. | <i>Leisurely</i> |
| 8..... | 25A 1.25, 70a 1.60.. | 2 85.. | <i>Lemans</i> |
| 10..... | 20A 1.15, 52a 1.65.. | 2 80.. | <i>Lemman</i> |
| 12..... | 14A 1.35, 42a 1.65.. | 3 00.. | <i>Lemniscate</i> |
| 18..... | 10A 1.30, 28a 2.00.. | 3 30.. | <i>Lemnade</i> |
| | | | <i>Lemures</i> |

Leaders.

Use word in code-word column with word for weight, as given on page 1183.

STYLE NO. 1 (REGULAR). Two Dots to the Em.

| | | | |
|-----------|----------|--------|--------------------|
| 5 Pt..... | per lb., | 1 20.. | <i>Lentoid</i> |
| 5½..... | | 74.. | <i>Lentous</i> |
| 6..... | | 64.. | <i>Lentrose</i> |
| 7..... | | 56.. | <i>Lentseed</i> |
| 8..... | | 52.. | <i>Lenzites</i> |
| 9..... | | 48.. | <i>Leonced</i> |
| 10..... | | 46.. | <i>Leonese</i> |
| 11..... | | 44.. | <i>Leonhardite</i> |
| 12..... | | 42.. | <i>Leonides</i> |

STYLE NO. 2 (CLOSE DOT). Three Dots to the Em.

| | | | |
|-----------|----------|--------|------------------|
| 5 Pt..... | per lb., | 1 20.. | <i>Leonine</i> |
| 5½..... | | 74.. | <i>Leoninely</i> |
| 6..... | | 64.. | <i>Leonist</i> |
| 7..... | | 56.. | <i>Leontist</i> |
| 8..... | | 52.. | <i>Leontodon</i> |
| 9..... | | 48.. | <i>Lepard</i> |
| 10..... | | 46.. | <i>Lepadite</i> |
| 11..... | | 44.. | <i>Lepers</i> |
| 12..... | | 42.. | <i>Lepidium</i> |

STYLE NO. 3 (WIDE DOT). One Dot to the Em.

| | | | |
|-----------|----------|--------|--------------------|
| 5 Pt..... | per lb., | 1 20.. | <i>Lenticular</i> |
| 6..... | | 64.. | <i>Lenticule</i> |
| 7..... | | 56.. | <i>Lentiform</i> |
| 8..... | | 52.. | <i>Lentigerous</i> |
| 9..... | | 48.. | <i>Lentiginous</i> |
| 10..... | | 46.. | <i>Lentil</i> |
| 11..... | | 44.. | <i>Lentiner</i> |
| 12..... | | 42.. | <i>Lentitude</i> |

STYLE NO. 4 (FINE-DOT HYPHEN). Four Strokes to the Em. (Fine-Dot Copper Alloy.)

| | | | |
|-----------|----------|------|-------------------|
| 6 Pt..... | per lb., | 64.. | <i>Leproustly</i> |
| 7..... | | 56.. | <i>Leptology</i> |
| 8..... | | 52.. | <i>Leriste</i> |
| 9..... | | 48.. | <i>Lernian</i> |
| 10..... | | 46.. | <i>Lesbian</i> |
| 11..... | | 44.. | <i>Lesion</i> |
| 12..... | | 42.. | <i>Lessee</i> |

Leaders—Continued.

STYLE NO. 5 (WIDE HYPHEN). Two Strokes to the Em.

| | | | |
|-----------|----------|----------|-------------------|
| 5 Pt..... | per lb., | \$1 20.. | <i>Lepidoid</i> |
| 5½..... | | 74.. | <i>Lepidotite</i> |
| 6..... | | 64.. | <i>Lepidopter</i> |
| 7..... | | 56.. | <i>Lepidotet</i> |
| 8..... | | 52.. | <i>Lepidotus</i> |
| 9..... | | 48.. | <i>Leporine</i> |
| 10..... | | 46.. | <i>Leprosity</i> |
| 11..... | | 44.. | <i>Leprosy</i> |
| 12..... | | 42.. | <i>Leprous</i> |

Leads and Slugs.

Uncut:

| | | |
|-------------------------|----------|------|
| 1 Pt..... | per lb., | 50.. |
| 1 1-5..... | | 40.. |
| 1½..... | | 32.. |
| 2 Pts. and thicker..... | | 16.. |

Cut 8 ems and longer and labor-saving founts:

| | | |
|-------------------------|----------|------|
| 1 Pt..... | per lb., | 64.. |
| 1 1-5..... | | 50.. |
| 1½..... | | 40.. |
| 2 Pts. and thicker..... | | 20.. |

Cut shorter than 8 ems:

| | | |
|-------------------------|----------|------|
| 1 Pt..... | per lb., | 68.. |
| 1 1-5..... | | 54.. |
| 1½..... | | 44.. |
| 2 Pts. and thicker..... | | 25.. |

LENTEN INITIALS (see Initials).

Lightface Celtic No. 150 F Limitation

| | | | |
|-----------|--------------------------|--------|------------------|
| 6 Pt..... | 22A \$1.25, 32a \$1.00.. | 2 25.. | <i>Limited</i> |
| 8..... | 20A 1.30, 30a 1.20.. | 2 50.. | <i>Limitedly</i> |
| 10..... | 18A 1.50, 28a 1.25.. | 2 75.. | <i>Limitless</i> |
| 12..... | 16A 1.60, 26a 1.40.. | 3 00.. | <i>Limner</i> |
| 18..... | 10A 1.65, 16a 1.60.. | 3 25.. | <i>Limoniad</i> |
| 24..... | 7A 1.85, 10a 1.65.. | 3 50.. | <i>Limonite</i> |
| 30..... | 5A 2.75, 7a 2.25.. | 5 00.. | <i>Limosella</i> |
| 36..... | 4A 3.25, 6a 3.00.. | 6 25.. | <i>Limosis</i> |
| 48..... | 3A 5.20, 4a 3.30.. | 8 50.. | <i>Limpets</i> |

Light-Face No. 158. F Longworded

| | | | |
|-----------|----------------------|--------|------------------|
| 6 Pt..... | 30A 1.40, 40a 1.10.. | 2 50.. | <i>Looketh</i> |
| 8..... | 24A 1.50, 36a 1.25.. | 2 75.. | <i>Looking</i> |
| 10..... | 24A 1.80, 32a 1.20.. | 3 00.. | <i>Lookout</i> |
| 12..... | 20A 1.75, 30a 1.50.. | 3 25.. | <i>Loomgate</i> |
| 18..... | 15A 2.10, 20a 1.40.. | 3 50.. | <i>Loophote</i> |
| 20..... | 12A 2.30, 16a 1.70.. | 4 00.. | <i>Loosed</i> |
| 24..... | 8A 2.50, 12a 2.00.. | 4 50.. | <i>Loosely</i> |
| 30..... | 7A 2.80, 8a 2.20.. | 5 00.. | <i>Looseness</i> |

Light Runic No. 110. o Lunatics

| | | | |
|------------|--------------------|--------|-----------------|
| 36 Pt..... | 5A 3.50, 8a 3.35.. | 6 85.. | <i>Lunation</i> |
| 48..... | 4A 4.85, 6a 4.50.. | 9 35.. | <i>Luncheon</i> |
| 60..... | 4A 5.00, 6a 4.35.. | 9 35.. | <i>Lunchman</i> |

Light Runic No. 152. F Lunettes

| | | | |
|------------|----------------------|--------|------------------|
| 10 Pt..... | 18A .95, 36a 1.05.. | 2 00.. | <i>Lungis</i> |
| 12..... | 20A 1.25, 40a 1.55.. | 2 80.. | <i>Lungwort</i> |
| 14..... | 14A 1.30, 20a 1.10.. | 2 40.. | <i>Luniform</i> |
| 18..... | 12A 1.70, 18a 1.60.. | 3 30.. | <i>Lunisolar</i> |
| 24..... | 10A 2.40, 16a 2.15.. | 4 55.. | <i>Lunistic</i> |
| 30..... | 8A 3.00, 12a 2.95.. | 5 95.. | <i>Lunital</i> |
| 42..... | 5A 3.70, 8a 3.55.. | 7 25.. | <i>Lunula</i> |

Lincoln. E

| | | | |
|------------|----------------------|--------|------------------|
| 10 Pt..... | 20A .95, 40a 1.05.. | 2 00.. | <i>Lupine</i> |
| 12..... | 12A 1.10, 24a 1.15.. | 2 25.. | <i>Lupulus</i> |
| 18..... | 10A 1.35, 20a 1.40.. | 2 75.. | <i>Lurcation</i> |
| 24..... | 8A 1.50, 16a 2.00.. | 3 50.. | <i>Lurcher</i> |
| 30..... | 6A 1.75, 12a 2.00.. | 3 75.. | <i>Lurchline</i> |
| 36..... | 5A 2.15, 10a 2.60.. | 4 75.. | <i>Lurdan</i> |
| 42..... | 4A 2.50, 8a 2.50.. | 5 00.. | <i>Luscious</i> |
| 48..... | 4A 3.00, 9a 3.00.. | 6 00.. | <i>Lusid</i> |
| 60..... | 3A 3.75, 6a 3.50.. | 7 25.. | <i>Luskishly</i> |

Lining Antique. c

| | | | |
|-----------|-----------------|--------|-------------------|
| 6 Pt..... | 41.....45A..... | 1 10.. | <i>Maasha</i> |
| 6..... | 42.....45A..... | 1 15.. | <i>Macadamize</i> |
| 6..... | 43.....45A..... | 1 30.. | <i>Macarized</i> |
| 6..... | 44.....45A..... | 1 60.. | <i>Macarizing</i> |
| 6..... | 45.....45A..... | 1 90.. | <i>Macaroni</i> |
| 8..... | 40.....36A..... | 2 00.. | <i>Macaronian</i> |

Lining Antique—Continued.

| | | | | | |
|--------------------|---------|-------|--------|-------|------------|
| 10 Pt. No. 40..... | 30A | | \$2 00 | | Macaroons |
| 12..... | 40..... | 25A | | 2 25 | Macassar |
| 18..... | 40..... | 14A | | 2 55 | Macawtree |
| 24..... | 40..... | 10A | | 3 20 | Maccabean |
| 30..... | 40..... | 8A | | 3 80 | Maccaboy |
| 36..... | 40..... | 6A | | 4 50 | Macebearer |

Lining Gothic Ext'd. No. 40. c *Madefy*

| | | | | | | |
|-----------|-----|---------|-----|---------|------|------------|
| 6 Pt..... | 25A | \$1.60, | 35a | \$1.40. | 3 00 | Madeira |
| 8..... | 20A | 1.60, | 30a | 1.40. | 3 00 | Madhouse |
| 10..... | 16A | 1.60, | 24a | 1.50. | 3 10 | Madjoun |
| 12..... | 14A | 1.70, | 22a | 1.70. | 3 40 | Madman |
| 14..... | 12A | 1.80, | 18a | 1.70. | 3 50 | Madnesses |
| 18..... | 10A | 2.30, | 14a | 2.00. | 4 30 | Madonna |
| 24..... | 7A | 2.40, | 10a | 2.10. | 4 50 | Madreporal |
| 30..... | 5A | 2.80, | 7a | 2.35. | 5 15 | Madrepore |
| 36..... | 4A | 3.80, | 6a | 3.30. | 7 10 | Madrier |

Lining Gothic No. 43. c

| | | | | | | | |
|--------------------|----------|-------|-------|-------|-----------|------------|---------|
| 6 Pt. No. 414..... | 60A | | 2 25 | | Magically | | |
| 6..... | 415..... | 60A | | 2 25 | Magicians | | |
| 6..... | 416..... | 60A | 2.25, | 70a | 1.45. | 3 70 | Magilph |
| 6..... | 417..... | 60A | 2.25, | 70a | 1.75. | 4 00 | Magilus |
| 8..... | 36A | 2.10, | 55a | 1.80. | 3 90 | Magister | |
| 9..... | 36A | 2.10, | 50a | 1.80. | 3 90 | Magistracy | |
| 10..... | 36A | 2.25, | 50a | 1.85. | 4 10 | Magistral | |
| 12..... | 25A | 2.20, | 40a | 2.00. | 4 20 | Magistrate | |
| 18..... | 14A | 2.40, | 25a | 2.55. | 4 95 | Magnality | |
| 24..... | 10A | 2.70, | 15a | 2.50. | 5 20 | Magnates | |
| 30..... | 8A | 3.50, | 12a | 3.10. | 6 60 | Magnesia | |
| 36..... | 6A | 3.90, | 9a | 3.20. | 7 10 | Magnesites | |

Lining Gothic No. 44. c

| | | | | | | | |
|--------------------|----------|-------|-------|-------|-----------|------------|------------|
| 6 Pt. No. 418..... | 50A | | 1 35 | | Magnesium | | |
| 6..... | 419..... | 50A | | 1 40 | Magnet | | |
| 6..... | 420..... | 50A | | 1 70 | Magnetics | | |
| 6..... | 421..... | 50A | | 1 70 | Magnetism | | |
| 6..... | 422..... | 50A | 2.65, | 70a | 1.80. | 2 35 | Magnetizer |
| 8..... | 36A | 2.00, | 55a | 1.80. | 3 80 | Magnifico | |
| 10..... | 28A | 2.10, | 45a | 1.95. | 4 05 | Magnified | |
| 12..... | 22A | 2.10, | 40a | 2.00. | 4 10 | Magnify | |
| 18..... | 14A | 2.55, | 22a | 2.20. | 4 75 | Magnifying | |
| 24..... | 10A | 3.10, | 15a | 2.55. | 5 65 | Magnitude | |
| 30..... | 8A | 3.75, | 12a | 3.20. | 6 95 | Magnolias | |
| 36..... | 6A | 4.40, | 8a | 3.25. | 7 65 | Maggie | |

Lining Gothic No. 45. c

| | | | | | | | |
|--------------------|----------|-------|-------|-------|------------|--------------|----------|
| 6 Pt. No. 423..... | 45A | | 1 45 | | Magyars | | |
| 6..... | 424..... | 45A | | 1 55 | Magydare | | |
| 6..... | 425..... | 45A | | 1 90 | Mahaleb | | |
| 6..... | 426..... | 45A | | 2 10 | Mahoganize | | |
| 6..... | 427..... | 45A | 2.55, | 70a | 1.90. | 4 45 | Mahogany |
| 8..... | 36A | 2.00, | 55a | 1.80. | 3 80 | Mahometan | |
| 9..... | 25A | 2.00, | 45a | 1.85. | 3 85 | Mahometist | |
| 10..... | 25A | 2.10, | 45a | 2.15. | 4 25 | Mahometistic | |
| 12..... | 20A | 2.10, | 30a | 1.90. | 4 00 | Mahometry | |
| 18..... | 12A | 2.40, | 18a | 2.05. | 4 45 | Mahound | |
| 24..... | 8A | 2.90, | 12a | 2.30. | 5 20 | Mahouts | |
| 30..... | 6A | 3.55, | 9a | 2.80. | 6 35 | Maiden | |
| 36..... | 4A | 3.65, | 7a | 3.15. | 6 80 | Maidenhair | |

Lining Roman No. 153. F

| | | | | | | | | |
|------------|----|-------|-----|-------|------|---------|------|------------|
| 18 Pt..... | 4A | .60, | 10A | 1.40, | 16a | 1.25. | 3 25 | Makebate |
| 24..... | 4A | .75, | 6A | 1.90, | 10a | 1.60. | 4 25 | Makeshift |
| 30..... | 3A | .85, | 5A | 2.25, | 7a | 1.50. | 4 60 | Makeweight |
| 36..... | 3A | 1.10, | 4A | 2.60, | 5a | 1.80. | 5 50 | Makings |
| 48..... | 4A | 4.50, | 5a | 3.00. | 7 50 | Malabar | | |

Lippincott. c

| | | | | | | |
|-----------|-----|-------|-----|-------|------|------------|
| 6 Pt..... | 35A | 1.10, | 52a | 1.15. | 2 25 | Malice |
| 8..... | 30A | 1.25, | 50a | 1.25. | 2 50 | Malicho |
| 10..... | 28A | 1.45, | 40a | 1.30. | 2 75 | Malicious |
| 12..... | 22A | 1.50, | 35a | 1.50. | 3 00 | Malign |
| 18..... | 12A | 1.70, | 18a | 1.55. | 3 25 | Malignancy |
| 24..... | 10A | 1.95, | 15a | 1.80. | 3 75 | Malignant |
| 30..... | 7A | 2.30, | 10a | 1.95. | 4 25 | Maligners |
| 36..... | 6A | 2.80, | 8a | 2.20. | 5 00 | Malignity |
| 48..... | 4A | 3.30, | 7a | 3.20. | 6 50 | Malingery |
| 60..... | 4A | 4.90, | 6a | 4.10. | 9 00 | Malison |

Listeners. E

| | | | |
|---------------|------|-------|--------|
| Per font..... | 1 50 | | Malkin |
|---------------|------|-------|--------|

Lithotint. E

| | | | | | | |
|------------|----|-------|-----|-------|------|-----------|
| 18 Pt..... | 8A | 2.35, | 16a | 2.40. | 4 75 | Manbote |
| 24..... | 6A | 2.70, | 12a | 2.80. | 5 50 | Manchet |
| 36..... | 4A | 3.40, | 8a | 3.35. | 6 75 | Mancineel |

Livermore. c

| | | | | | | |
|-----------|-----|---------|-----|---------|--------|------------|
| 6 Pt..... | 15A | \$1.00, | 60a | \$1.50. | \$2 50 | Mancus |
| 8..... | 15A | 1.15, | 55a | 1.60. | 2 75 | Mandamus |
| 10..... | 15A | 1.25, | 55a | 1.75. | 3 00 | Mandarin |
| 12..... | 15A | 1.40, | 50a | 1.85. | 3 25 | Mandatory |
| 18..... | 9A | 1.70, | 28a | 2.05. | 3 75 | Mandates |
| 24..... | 6A | 1.95, | 18a | 2.30. | 4 25 | Mandible |
| 30..... | 5A | 2.40, | 12a | 2.35. | 4 75 | Mandibular |
| 36..... | 4A | 2.60, | 10a | 2.65. | 5 25 | Mandilion |
| 48..... | 3A | 3.40, | 6a | 2.85. | 6 25 | Mandioc |
| 60..... | 3A | 5.55, | 4a | 2.70. | 8 25 | Mandment |

Livermore Outline. c

| | | | | | | |
|------------|----|-------|-----|-------|------|------------|
| 24 Pt..... | 6A | 1.95, | 18a | 2.30. | 4 25 | Manducable |
| 30..... | 5A | 2.40, | 12a | 2.35. | 4 75 | Manducates |
| 36..... | 4A | 2.60, | 10a | 2.65. | 5 25 | Manducus |
| 48..... | 3A | 3.40, | 6a | 2.85. | 6 25 | Manege |
| 60..... | 3A | 5.55, | 4a | 2.70. | 8 25 | Manewer |

Longfellow. c

| | | | | | | |
|-----------|-----|-------|-----|-------|-------|------------|
| 8 Pt..... | 14A | 1.20, | 40a | 1.80. | 3 00 | Manful |
| 10..... | 14A | 1.40, | 40a | 2.10. | 3 50 | Manfully |
| 12..... | 14A | 1.60, | 40a | 2.40. | 4 00 | Manfulness |
| 18..... | 9A | 1.95, | 22a | 2.55. | 4 50 | Mangaby |
| 24..... | 7A | 2.25, | 16a | 2.75. | 5 00 | Manganate |
| 30..... | 5A | 2.35, | 14a | 3.65. | 6 00 | Manganasic |
| 36..... | 4A | 2.70, | 12a | 4.30. | 7 00 | Manganium |
| 42..... | 4A | 3.30, | 10a | 4.70. | 8 00 | Mangcorn |
| 48..... | 4A | 3.60, | 10a | 5.40. | 9 00 | Manger |
| 54..... | 4A | 4.80, | 9a | 5.20. | 10 00 | Mangily |
| 60..... | 4A | 5.00, | 9a | 6.00. | 11 00 | Mangle |
| 72..... | 3A | 5.95, | 6a | 6.05. | 12 00 | Mangobird |

Luray. c

| | | | | | |
|------------|----|-------|------|-------|-----------|
| 18 Pt..... | 6A | | 2 70 | | Mannishly |
| 24..... | 5A | | 3 35 | | Mannite |
| 30..... | 4A | | 4 30 | | Manometer |
| 36..... | 3A | | 5 40 | | Manorial |

McCullagh. F

| | | | | | | |
|------------|-----|-------|-----|-------|------|------------|
| 10 Pt..... | 20A | 1.50, | 26a | 1.25. | 2 75 | Maranatha |
| 12..... | 16A | 1.60, | 20a | 1.40. | 3 00 | Maranta |
| 18..... | 10A | 1.75, | 14a | 1.50. | 3 25 | Maraschino |
| 24..... | 8A | 1.90, | 12a | 2.10. | 4 00 | Marasmus |
| 30..... | 7A | 2.00, | 10a | 2.25. | 4 25 | Maraud |
| 36..... | 6A | 2.75, | 9a | 2.75. | 5 50 | Marauders |
| 42..... | 5A | 3.10, | 8a | 2.90. | 6 00 | Marauding |
| 48..... | 4A | 3.15, | 7a | 3.35. | 6 50 | Maravedi |
| 60..... | 3A | 4.50, | 5a | 4.00. | 8 50 | Marble |
| 72..... | 3A | 5.25, | 5a | 4.25. | 9 50 | Marcasite |

Madisonian. A

| | | | | | | |
|------------|----|-------|-----|-------|------|--------|
| 10 Pt..... | 5A | 1.25, | 26a | 1.50. | 2 75 | Marcid |
|------------|----|-------|-----|-------|------|--------|

Magnolia Script. A

| | | | | | | |
|------------|----|-------|-----|-------|------|------------|
| 24 Pt..... | 7A | 3.00, | 20a | 4.00. | 7 00 | Marcionite |
|------------|----|-------|-----|-------|------|------------|

Mail-List Logotypes. D-E-F

Use word in code-word column with word for weight, as given on page 1183.

| | | | | |
|---------------------------|----------|----|-------|------------|
| 8 Pt. Em-set No. 150..... | per lb., | 52 | | Margaron |
| 9 Pt. En-set | 150 | 48 | | Margay |
| 10 Pt. En-set | 114 | 46 | | Margent |
| 10 Pt. Em-set | 120 | 46 | | Marginal |
| 10 Pt. En-set | 121 | 46 | | Margosa |
| 10 Pt. Em-set | 122 | 46 | | Margrave |
| 10 Pt. En-set | 123 | 46 | | Marigold |
| 10 Pt. | 124 | 46 | | Mariograph |

MAIL-LIST TYPE (see Time-Saving Mail-list Type).

Maltese Crosses. B

| | | | | |
|--------------------|----------------------|----|-------|---------|
| 301B to 304B..... | eight of any size, | 25 | | |
| 305B..... | per set of eight, | 30 | | Marital |
| 306B and 307B..... | four of either size, | 35 | | |
| 308B and 309B..... | four of either size, | 50 | | |
| 310B and 313B..... | each, | 20 | | |
| 311B and 312B..... | each, | 25 | | |
| 314B and 315B..... | four of either size, | 50 | | |
| 316B and 317B..... | four of either size, | 35 | | |

Manilla Border. A

| | | | |
|---------------------------|------|-------|-----------|
| Per font, 30 inches | 1 50 | | Maritaded |
|---------------------------|------|-------|-----------|

Manuscript. A

| | | | | | | | |
|-------------------|--------|-------|-------|-------|-------|---------|------------|
| 16 Pt. No. 1..... | 10A | 2.15, | 44a | 3.85. | 6 00 | Mastoid | |
| 16..... | 2..... | 10A | 2.15, | 40a | 3.85. | 6 00 | Mastoidcal |
| 24..... | 1..... | 6A | 2.50, | 22a | 4.50. | 7 00 | Mastology |
| 24..... | 2..... | 6A | 2.50, | 20a | 4.50. | 7 00 | Masturbari |

MARGIN ORNAMENTS (see Ornaments).

Mediæval No. 10. A Medicate
24 Pt. 5A \$2.15, 10a \$1.35, \$3 50... Medicateth
30 4A 2.20, 8a 1.50... 3 70... Mediccan
42 4A 3.90, 6a 2.00... 5 90... Medicinal

Medical Signs No. 150. F
6 Pt. per font, 1 00... Meliority
7 1 00... Meliphagan
8 1 00... Mellate
9 1 00... Mellific
10 1 00... Melligo
11 1 00... Mellites
12 1 00... Mellower

Mercantile. A Member
6 Pt. 30A \$1.00, 30A 1.25... 2 25... Membership
8 20A .65, 20A 1.10... 1 75... Membrane
10 18A .75, 18A 1.25... 2 00... Membranous
11 16A .85, 16A 1.40... 2 25... Memento
12 14A 1.00, 14A 1.50... 2 50... Memonon
14 12A 1.00, 12A 1.75... 2 75... Memoirs
16 10A 1.00, 10A 2.00... 3 00... Memorably

Mercantile Bold. A
18 Pt. 8A... 2 50... Memorative
20 7A... 2 75... Memorial
24 6A... 3 00... Memorist
36 5A... 4 00... Memoriter
48 5A... 4 00... Memorized

METAL BRACES (see Braces).

Metal Corner Quads.
6 Pt. per set of four, 20... Menaco
12 per set of four, 20... Menacing

Metal Furniture.
Per lb. 25
12 lb. font. 3 00... Mercable
25 6 25... Mercantile
50 12 50... Mercaptan
75 18 75... Mercaptide
100 25 00... Mercatante

Midget Tail Pieces. H
Per font 1 25... Metalman

Mid-Gothic. F Metameric
6 Pt. 24A 1.15, 36a 1.10... 2 25... Metaphor
8 22A 1.30, 30a 1.20... 2 50... Metaphoric
10 20A 1.50, 26a 1.25... 2 75... Metaphrase
12 16A 1.75, 20a 1.25... 3 00... Metaphysic
14 12A 1.65, 18a 1.60... 3 25... Metaplasm
18 12A 1.90, 16a 1.60... 3 50... Metastasis
24 9A 2.10, 12a 1.90... 4 00... Metastatic
30 7A 2.15, 10a 2.10... 4 25... Metatarsal
36 6A 2.60, 9a 2.40... 5 00... Metatarsus
42 5A 3.50, 8a 3.00... 6 50... Metathesis
48 4A 3.75, 6a 3.50... 7 25... Metathorax
54 3A 4.25, 5a 3.75... 8 00... Metatome
60 3A 6.00, 4a 4.00... 10 00... Metayer
72 3A 8.40, 4a 5.60... 14 00... Metecorn

Milan. A Micropyle
10 Pt 24A 1.30, 46a 1.45... 2 75... Microscope
12 20A 1.50, 36a 1.50... 3 00... Microtome
18 15A 1.75, 23a 1.50... 3 25... Middle

MISSAL INITIALS (see Initials).

Modern Antique. D Miscognize
6 Pt. 30A 1.25, 60a 1.25... 2 50... Miscompute
8 30A 1.50, 60a 1.50... 3 00... Misonceit
10 24A 1.50, 50a 1.50... 3 00... Misonduct
12 20A 1.50, 40a 1.50... 3 00... Miscorreet
18 16A 1.95, 24a 1.95... 3 90... Miscreancy
20 12A 2.25, 20a 2.25... 4 50... Miscreant
30 10A 3.20, 16a 3.20... 6 40... Miscreated
36 8A 4.25, 12a 4.25... 8 50... Misdeeds
42 6A 4.45, 10a 4.45... 8 90... Misdeem
48 5A 5.45, 8a 5.45... 10 90... Misdeeming
60 4A 5.15, 5a 5.10... 10 25... Misdeemans
72 3A 5.60, 4a 5.60... 11 20... Misdepart

Mod. Antique Wide No. 110. D Mislived
12 Pt. 20A 1.85, 30a 1.80... 3 65... Misluck
18 10A 1.90, 16a 1.85... 3 75... Mislake
20 10A 2.45, 16a 2.40... 4 85... Mismanage
30 6A 2.80, 8a 2.80... 5 60... Mismarked
36 4A 3.50, 6a 3.50... 7 00... Mismarking
48 3A 4.45, 4a 4.45... 8 90... Mismatch

Modern Black No. 2. B Missals
6 Pt. 20A 50a \$3 00... Misseek
8 12A 40a 3 00... Misselbird
10 10A \$1.10, 25a \$1.40... 2 50... Misseldine
12 8A 1.10, 20a 1.40... 2 50... Misserved
14 12A 1.60, 20a 1.60... 3 20... Misserving
18 6A 1.35, 15a 1.60... 2 95... Misshapen

Modern Fraktur. B Misshaping
6 Pt. 15A .85, 50a 1.15... 2 00... Missile
8 15A .95, 50a 1.35... 2 30... Missingly
9 15A 1.20, 50a 1.40... 2 60... Mission
10 12A 1.00, 40a 1.25... 2 25... Missionary
11 12A 1.10, 40a 1.30... 2 40... Missives
12 12A 1.35, 40a 1.65... 3 00... Missound
14 9A 1.25, 30a 1.55... 2 80... Misspeak
18 6A 1.30, 20a 1.40... 2 70... Misspender
24 6A 1.90, 20a 2.15... 4 05... Misspent
30 5A 2.30, 15a 2.60... 4 90... Missitated
42 4A 3.25, 10a 3.30... 6 55... Misstating

Modern Roman No. 17. C
3 1/2 Pt. Card font 2 lbs. 10 00... Mistful
4 1/2 Card font 3 lbs. 7 50... Misthink

Modern Roman No. 18. C
4 1/2 Card font 3 lbs. 10 50... Misthought

Modern Text No. 2. B Miswander
8 Pt. 15A 2.00, 40a 2.00... 4 00... Miswed
10 15A 2.25, 40a 2.00... 4 25... Miswedded
12 10A 2.35, 30a 2.15... 4 50... Miswedding
14 10A 2.50, 25a 2.25... 4 75... Miswrite
18 10A 3.25, 25a 3.35... 6 60... Miswritten
24 8A 3.05, 20a 3.15... 6 20... Miswrought
30 4A 2.90, 12a 3.05... 5 95... Miswoked
36 4A 4.10, 12a 4.30... 8 40... Miswoking
48 4A 8.00, 12a 6.00... 14 00... Miszealous
60 3A 7.00, 6a 5.00... 12 00... Mitella

Modern Text No. 40. C Mithras
12 Pt. 12A 1.80, 32a 2.35... 4 15... Mithridate
18 10A 2.25, 28a 2.55... 4 80... Mitigable
24 8A 2.50, 20a 2.70... 5 20... Mitigated
30 6A 3.35, 14a 3.10... 6 45... Mitigating
36 6A 4.80, 14a 5.05... 9 85... Mitigatory
48 5A 10a 12 60... Mitriiform
60 3A 5a 10 35... Mitimus

Morning Glory. F Montem
18 Pt. 12A 1.50, 32a 1.75... 3 25... Montero
24 12A 2.15, 20a 1.85... 4 00... Montezuma
36 7A 2.75, 12a 2.25... 5 00... Monthling

MORRIS INITIALS (see Initials).

Mortised. C Mopishness
6 Pt. 25A... 1 45... Mopsey
9 22A... 1 80... Mopuses
12 18A... 2 10... Moraine
18 12A... 2 50... Moralist
24 9A... 3 00... Morality
36 5A... 4 30... Moralityzed
48 3A... 5 70... Moratizing

Mortised Initial Ornaments. C
Large size each, 80...
Medium size, 70...
Small size, 60...

MORTISED NO. 2 INITIALS (see Initials).

Multiform No. 1. F Mortlings
18 Pt. 8A... 2 75... Mortmain
24 6A... 3 25... Mortpay
30 5A... 3 75... Mortwre
36 4A... 4 25... Mortuary

Multiform No. 2. F Mosaically
18 Pt. 8A... 2 75... Mosasaurus
24 6A... 3 25... Moschatel
30 5A... 3 75... Moschina
36 4A... 4 25... Moschus

Multiform No. 3. F Mosques
18 Pt. 8A... 2 75... Mosquito
24 6A... 3 25... Mossagateer
30 5A... 3 75... Mossbunk
36 4A... 4 25... Mosspink

| | | |
|---------------------------|---------|-------------------------|
| Multiform No. 4. F | | <i>Mossrose</i> |
| 18 Pt..... | 8A..... | \$2 75.. <i>Mostick</i> |
| 24..... | 6A..... | 3 25.. <i>Mostihiba</i> |
| 30..... | 5A..... | 3 75.. <i>Motacilla</i> |
| 36..... | 4A..... | 4 25.. <i>Motella</i> |

MULTIPLE INITIALS (see Initials).

| | | |
|------------------|--------------------------|-------------------------|
| Munich. A | | <i>Motion</i> |
| 18 Pt..... | 10A \$1.80, 15a \$1.45.. | 3 25.. <i>Motioneth</i> |
| 24..... | 7A 2.30, 10a 1.70.. | 4 00.. <i>Motioning</i> |
| 36..... | 4A 2.80, 6a 2.20.. | 5 00.. <i>Motionly</i> |
| 48..... | 3A 3.65, 5a 2.85.. | 6 50.. <i>Motives</i> |

| | | |
|-----------------|----------|--------------------------|
| Mural. A | | <i>Mournfully</i> |
| 6 Pt..... | 26A..... | 1 50.. <i>Mourning</i> |
| 8..... | 26A..... | 1 75.. <i>Mourningty</i> |
| 10..... | 20A..... | 2 00.. <i>Mousehawk</i> |
| 12..... | 18A..... | 2 25.. <i>Mousehote</i> |
| 18..... | 10A..... | 2 50.. <i>Mousehunt</i> |
| 20..... | 9A..... | 2 50.. <i>Mousetrap</i> |
| 24..... | 8A..... | 3 25.. <i>Mousetline</i> |
| 30..... | 6A..... | 3 50.. <i>Mouthfuls</i> |
| 36..... | 6A..... | 4 25.. <i>Mouthglass</i> |
| 42..... | 5A..... | 4 75.. <i>Mouthpiece</i> |
| 48..... | 4A..... | 5 25.. <i>Motivables</i> |

MURAL ORNAMENTS (see Ornaments).

| | | |
|----------------------|--------------------|-----------------------|
| Music Type. C | | <i>Smallest font.</i> |
| Excelsior..... | 15 lbs. @ \$3.60.. | 54 00.. |
| | No. 2 15..... | 3.60.. 54 00.. |
| | 3 15..... | 3.60.. 54 00.. |
| Diamond No. 1..... | 30..... | 3.20.. 96 00.. |
| | 2 30..... | 3.20.. 96 00.. |
| | 3 30..... | 3.20.. 96 00.. |
| | 4 30..... | 3.20.. 96 00.. |
| Agate No. 3..... | 30..... | 2.40.. 72 00.. |
| Nonpareil No. 3..... | 30..... | 2.00.. 60 00.. |

| | | |
|--------------------------|------------|-------------------------|
| Myrtle Borders. H | | <i>Muckrake</i> |
| 6 Pt..... | 42 inches, | 1 75.. <i>Mucksweet</i> |
| 12..... | 36..... | 1 75.. <i>Muckworm</i> |
| 18..... | 36..... | 2 00.. <i>Mucoccle</i> |

NEPTUNE INITIALS (see Initials).

| | |
|---------------------------------------|----------------------|
| New Index Cuts. | |
| Per set (two of each, right and left) | 1 50.. <i>Nabbed</i> |

NEW METAL BRACES (see Braces).

| | | |
|---------------------------|------------|---------------------------|
| Newspaper Borders. | | |
| 6 Pt. No. 71..... | 48 inches, | 1 25.. <i>Nectar</i> |
| 6..... | 48..... | 1 25.. <i>Nectarreal</i> |
| 6..... | 73..... | 1 25.. <i>Nectarceous</i> |
| 6..... | 74..... | 1 25.. <i>Nectarine</i> |
| 6..... | 75..... | 1 25.. <i>Nectarized</i> |
| 6..... | 76..... | 1 25.. <i>Necturous</i> |
| 6..... | 77..... | 1 25.. <i>Nedder</i> |
| 6..... | 78..... | 1 25.. <i>Needeth</i> |
| 6..... | 79..... | 1 25.. <i>Needful</i> |
| 6..... | 80..... | 1 25.. <i>Neediness</i> |
| 6..... | 81..... | 1 25.. <i>Needle</i> |
| 6..... | 82..... | 1 25.. <i>Needlebook</i> |
| 6..... | 83..... | 1 25.. <i>Needlefish</i> |
| 6..... | 84..... | 1 25.. <i>Needleful</i> |
| 12..... | 57..... | 75.. <i>Negroloid</i> |
| 12..... | 58..... | 75.. <i>Negundo</i> |
| 12..... | 61..... | 75.. <i>Neighborly</i> |
| 12..... | 62..... | 75.. <i>Neighings</i> |
| 12..... | 63..... | 75.. <i>Nemaline</i> |
| 12..... | 64..... | 75.. <i>Nematoid</i> |
| 12..... | 66..... | 75.. <i>Nemesis</i> |
| 12..... | 67..... | 75.. <i>Nemophily</i> |
| 12..... | 68..... | 75.. <i>Nemorous</i> |
| 12..... | 69..... | 75.. <i>Nempne</i> |
| 12..... | 70..... | 75.. <i>Nenuphar</i> |
| 12..... | 71..... | 75.. <i>Neocomian</i> |
| 12..... | 72..... | 75.. <i>Neocracy</i> |
| 12..... | 73..... | 75.. <i>Neodamode</i> |
| 12..... | 74..... | 75.. <i>Neogamist</i> |
| 12..... | 75..... | 75.. <i>Neography</i> |
| 12..... | 76..... | 75.. <i>Neologian</i> |
| 12..... | 77..... | 75.. <i>Neotogist</i> |
| 12..... | 78..... | 1 50.. <i>Neophite</i> |
| 12..... | 79..... | 1 50.. <i>Neoplastic</i> |
| 12..... | 80..... | 75.. <i>Neoteric</i> |
| 12..... | 81..... | 75.. <i>Neoterical</i> |
| 12..... | 82..... | 1 50.. <i>Nepantese</i> |
| 12..... | 83..... | 75.. <i>Nepenthe</i> |
| 12..... | 84..... | 75.. <i>Nepeta</i> |
| 18..... | 4..... | 1 00.. <i>Nervous</i> |

Newspaper Borders—Continued.

| | | |
|-------------------|------------|---------------------------|
| 18 Pt. No. 5..... | 24 inches, | \$1 00.. <i>Nervously</i> |
| 18..... | 7..... | 1 00.. <i>Nestegg</i> |
| 18..... | 13..... | 1 00.. <i>Network</i> |
| 18..... | 16..... | 1 00.. <i>Neuropter</i> |
| 18..... | 18..... | 1 00.. <i>Neurotic</i> |
| 18..... | 19..... | 1 00.. <i>Neurotome</i> |
| 18..... | 20..... | 1 00.. <i>Neuter</i> |
| 18..... | 21..... | 1 00.. <i>Neutrality</i> |
| 18..... | 22..... | 1 00.. <i>Neutralize</i> |
| 18..... | 23..... | 1 00.. <i>Newaines</i> |
| 18..... | 24..... | 1 00.. <i>Newborn</i> |
| 24..... | 2..... | 1 50.. <i>Niceness</i> |
| 24..... | 3..... | 1 50.. <i>Niceties</i> |
| 24..... | 4..... | 1 50.. <i>Nickartree</i> |
| 24..... | 5..... | 1 50.. <i>Nickel</i> |
| 36..... | 1..... | 2 00.. <i>Nidorose</i> |

Newspaper Headings.

| | | |
|----------------------|---|--|
| ELECTROTYPED. | | |
| | 4 Col. 5 Col. 6 Col. 7 Col. 8 Col. 9 Col. | |
| 4-line.. | \$2.00.. \$2.25.. \$2.50.. \$2.75.. \$3.00.. \$3.25 | |
| 5-line.. | 2.25.. 2.50.. 2.75.. 3.00.. 3.25.. 3.50 | |
| 6-line.. | 2.50.. 2.75.. 3.00.. 3.25.. 3.50.. 3.75 | |
| 7-line.. | 2.75.. 3.00.. 3.25.. 3.50.. 3.75.. 4.00 | |
| 8-line.. | 3.00.. 3.25.. 3.50.. 3.75.. 4.00.. 4.25 | |
| 9-line.. | 3.25.. 3.50.. 3.75.. 4.00.. 4.25.. 4.50 | |
| 10-line.. | 3.50.. 3.75.. 4.00.. 4.25.. 4.50.. 4.75 | |

| | | |
|---------------------------|--|--------|
| BRASS. | | |
| One word..... | | 4 00.. |
| Two words..... | | 6 00.. |
| Each additional word..... | | 1 50.. |

| | | |
|---------------------|-------|--------|
| SUBHEADINGS. | | |
| Electrotyped..... | each, | 50.. |
| Brass..... | | 1 50.. |

NINE POINT BORDERS (see Nonpareil and One-Half Borders).

NONAME INITIALS (see Initials).

| | | |
|---------------------------|--------------|---------------------------|
| Nonpareil Borders. | | |
| No. 201..... | 10 feet..... | 2 60.. <i>Nightcrow</i> |
| | 202..... | 2 60.. <i>Nightfall</i> |
| | 203..... | 2 60.. <i>Nightfaring</i> |
| | 204..... | 2 60.. <i>Nightflier</i> |
| | 205..... | 2 60.. <i>Nightglass</i> |
| | 206..... | 2 60.. <i>Nightgown</i> |
| | 207..... | 2 60.. <i>Nighthag</i> |
| | 208..... | 2 60.. <i>Nighthawk</i> |
| | 209..... | 2 60.. <i>Nightheron</i> |
| | 211..... | 2 60.. <i>Nightmare</i> |
| | 212..... | 2 60.. <i>Nightrail</i> |
| | 213..... | 2 60.. <i>Nightraven</i> |
| | 214..... | 2 60.. <i>Nightrule</i> |
| | 215..... | 2 60.. <i>Nights</i> |
| | 217..... | 2 60.. <i>Nightshirt</i> |
| | 218..... | 2 60.. <i>Nightspell</i> |
| | 219..... | 2 60.. <i>Nightward</i> |
| | 220..... | 2 60.. <i>Nightwatch</i> |
| | 221..... | 2 60.. <i>Nigrescent</i> |
| | 222..... | 2 60.. <i>Nihilism</i> |
| | 223..... | 2 60.. <i>Nihilistic</i> |
| | 224..... | 2 60.. <i>Nihility</i> |
| | 225..... | 2 60.. <i>Nilometer</i> |
| | 226..... | 2 60.. <i>Niloscope</i> |
| | 227..... | 2 60.. <i>Nilotic</i> |
| | 228..... | 2 60.. <i>Nimbleness</i> |
| | 229..... | 2 60.. <i>Nimblest</i> |
| | 230..... | 2 60.. <i>Nimby</i> |
| | 231..... | 2 60.. <i>Nimbus</i> |
| | 232..... | 2 60.. <i>Nimiety</i> |
| | 233..... | 2 60.. <i>Nincompoop</i> |
| | 234..... | 2 60.. <i>Ninefold</i> |
| | 235..... | 2 60.. <i>Nineholes</i> |
| | 236..... | 2 60.. <i>Ninepins</i> |
| | 237..... | 2 60.. <i>Ninthly</i> |
| | 240..... | 2 60.. <i>Nipperkin</i> |
| | 242..... | 2 60.. <i>Nippitate</i> |
| | 243..... | 2 60.. <i>Nippitatum</i> |
| | 244..... | 2 60.. <i>Nipple</i> |
| | 245..... | 2 60.. <i>Nippleworth</i> |
| | 246..... | 2 60.. <i>Nitency</i> |
| | 247..... | 2 60.. <i>Nitrated</i> |
| | 248..... | 2 60.. <i>Nitratine</i> |
| | 249..... | 2 60.. <i>Nitrify</i> |
| | 250..... | 2 60.. <i>Nitrogen</i> |
| | 251..... | 2 60.. <i>Nitrometer</i> |
| | 252..... | 2 60.. <i>Nitrous</i> |
| | 253..... | 2 60.. <i>Nivose</i> |

Nonp. and One-Half Borders. D

| | | | |
|------------|--------------|--------|--------------|
| No. 4..... | 10 feet..... | \$3 00 | ...Nocturn |
| 5..... | 10..... | 3 00 | ...Nocturnal |
| 6..... | 10..... | 3 00 | ...Nocuous |
| 7..... | 10..... | 3 00 | ...Nocuously |
| 9..... | 10..... | 3 00 | ...Nodded |
| 10..... | 10..... | 3 00 | ...Nodding |
| 12..... | 10..... | 3 00 | ...Noddlle |
| 13..... | 10..... | 3 00 | ...Nodicole |
| 14..... | 10..... | 3 00 | ...Nodose |
| 15..... | 10..... | 3 00 | ...Nodosity |
| 16..... | 10..... | 3 00 | ...Nodular |
| 17..... | 10..... | 3 00 | ...Nodulous |

Norman Condensed. B

| | | |
|------------------------------------|------|---------------|
| 10 Pt. 32A \$1.53, 20A \$1.40..... | 2 93 | ...Nombril |
| 12.....32A 1.55, 20A 1.40..... | 2 95 | ...Nominatist |
| 18.....16A 1.65, 10A 1.50..... | 3 15 | ...Nominated |
| 24.....8A 1.80, 5A 2.03..... | 3 83 | ...Nominately |
| 36.....6A 2.50, 5A 2.00..... | 4 50 | ...Nominative |

Norman Italic. A

| | | | |
|-----------|-----------------------------------|------|---------------|
| 8 Pt..... | 28A 1.25, 70a \$1.50..... | 2 75 | ...Noontide |
| 10..... | 24A 1.40, 62a 1.85..... | 3 25 | ...Nopatry |
| 12..... | 16A 1.48, 28A 1.48, 60a 2.31..... | 5 27 | ...Normal |
| 18..... | 16A 1.48, 28A 1.48, 32a 1.30..... | 4 26 | ...Normalcy |
| 24..... | 8A 1.62, 12A 1.31, 50a 3.14..... | 6 07 | ...Normans |
| 30..... | 8A 1.62, 12A 1.31, 16a 1.45..... | 4 38 | ...Norroy |
| 36..... | 6A 1.32, 8A 1.60, 36a 3.68..... | 6 60 | ...Northerner |
| 42..... | 6A 1.32, 8A 1.60, 14a 1.70..... | 4 62 | ...Northers |
| 48..... | 5A 1.70, 6A 1.90, 24a 3.64..... | 7 24 | ...Northing |
| 54..... | 5A 1.70, 6A 1.90, 10a 1.62..... | 5 22 | ...Northmost |

Novelty Script. F

| | | | |
|------------|------------------------|-------|---------------|
| 18 Pt..... | 5A 1.75, 16a 2.25..... | 4 00 | ...Nostril |
| 24..... | 5A 2.50, 12a 2.75..... | 5 25 | ...Nostrums |
| 36..... | 4A 3.75, 8a 3.50..... | 7 25 | ...Notability |
| 48..... | 3A 4.50, 6a 4.50..... | 9 00 | ...Notably |
| 60..... | 3A 6.75, 5a 5.00..... | 11 75 | ...Notandum |
| 72..... | 3A 10.00, 4a 6.00..... | 16 00 | ...Notarial |

Obelisk. c

| | | | |
|------------|-------------------------|------|---------------|
| 16 Pt..... | 10A 1.30, 14a 1.20..... | 2 50 | ...Obituary |
| 24..... | 7A 1.60, 10a 1.60..... | 3 20 | ...Objectify |
| 36..... | 5A 3.05, 7a 2.10..... | 5 15 | ...Objective |
| 48..... | 4A 3.00, 6a 2.75..... | 5 75 | ...Objectors |
| 60..... | 3A 3.70, 5a 2.80..... | 6 50 | ...Objurgated |

Octic No. 1. D

| | | | |
|-----------|----------|------|--------------|
| 6 Pt..... | 30A..... | 1 50 | ...Obtaineth |
| 8..... | 30A..... | 2 00 | ...Obtaining |
| 10..... | 20A..... | 1 45 | ...Obtends |
| 12..... | 20A..... | 2 00 | ...Obtension |
| 16..... | 15A..... | 2 00 | ...Obtosting |
| 20..... | 8A..... | 2 30 | ...Obtrude |
| 24..... | 8A..... | 3 00 | ...Obtruders |
| 30..... | 6A..... | 3 00 | ...Obtruding |
| 36..... | 5A..... | 4 40 | ...Obtrusive |
| 42..... | 4A..... | 4 40 | ...Obtrudent |
| 48..... | 4A..... | 6 35 | ...Obturator |

Octic No. 2. D

| | | | |
|-----------|----------|------|---------------|
| 6 Pt..... | 30A..... | 1 60 | ...Obtusely |
| 8..... | 30A..... | 1 95 | ...Obtuseness |
| 10..... | 30A..... | 2 00 | ...Obumbrate |
| 12..... | 20A..... | 2 10 | ...Obuncous |
| 16..... | 15A..... | 2 40 | ...Obvention |
| 18..... | 12A..... | 2 25 | ...Obverse |
| 20..... | 8A..... | 2 30 | ...Obversety |
| 24..... | 8A..... | 2 95 | ...Obviates |
| 30..... | 6A..... | 3 20 | ...Obviating |
| 36..... | 5A..... | 3 80 | ...Obvious |
| 42..... | 4A..... | 4 25 | ...Obviousty |

Old Style Antique No. 40. c

| | | | |
|------------|------------------------|------|--------------|
| 30 Pt..... | 8A 3.15, 12a 2.85..... | 6 00 | ...Odorating |
| 36..... | 6A 3.85, 9a 3.25..... | 7 10 | ...Odorine |
| 48..... | 4A 4.25, 6a 3.75..... | 8 00 | ...Odorous |

Old Style Antique No. 112. D

| | | | |
|------------|----------|------|---------------|
| 12 Pt..... | 18A..... | 1 80 | ...Offspring |
| 18..... | 14A..... | 2 45 | ...Offward |
| 20..... | 12A..... | 3 15 | ...Oftenest |
| 24..... | 10A..... | 3 75 | ...Ofstensith |
| 36..... | 7A..... | 4 50 | ...Ofentimes |
| 42..... | 5A..... | 4 80 | ...Ogives |
| 48..... | 4A..... | 5 00 | ...Ogling |

Old Style Antique No. 120. E

| | | | |
|-----------|-----------------------------|--------|--------------|
| 6 Pt..... | 24A \$0.90, 48a \$1.10..... | \$2 00 | ...Oglios |
| 8..... | 20A 1.00, 40a 1.10..... | 2 10 | ...Ogygian |
| 10..... | 18A 1.10, 36a 1.25..... | 2 35 | ...Oilbag |
| 12..... | 16A 1.35, 32a 1.50..... | 2 85 | ...Oilbeetle |
| 18..... | 12A 2.05, 24a 2.25..... | 4 30 | ...Oilcloth |
| 20..... | 10A 2.20, 20a 2.40..... | 4 60 | ...Oilcolors |
| 24..... | 8A 2.65, 16a 3.15..... | 5 80 | ...Oiliness |

Old Style Bold. F

| | | | |
|-----------|-------------------------|-------|---------------|
| 6 Pt..... | 16A 1.70, 22a 1.30..... | 3 00 | ...Omissible |
| 8..... | 18A 1.90, 24a 1.60..... | 3 50 | ...Omissions |
| 10..... | 15A 2.00, 20a 1.50..... | 3 50 | ...Omissive |
| 12..... | 14A 2.30, 18a 1.70..... | 4 00 | ...Omissively |
| 18..... | 7A 2.60, 10a 1.90..... | 4 50 | ...Omittance |
| 24..... | 5A 3.30, 7a 2.70..... | 6 00 | ...Omitters |
| 36..... | 4A 5.60, 6a 3.90..... | 9 50 | ...Omnibus |
| 48..... | 4A 8.80, 6a 6.20..... | 15 00 | ...Omniety |

Old Style Cond. No. 4. D

| | | | |
|------------|-------------------------|------|--------------|
| 12 Pt..... | 25A 1.30, 40a 1.10..... | 2 40 | ...Onerous |
| 18..... | 20A 1.95, 30a 1.35..... | 3 30 | ...Onerously |
| 24..... | 15A 2.05, 20a 1.55..... | 3 60 | ...Onesided |
| 36..... | 10A 2.40, 15a 2.10..... | 4 50 | ...Oneyer |
| 42..... | 6A 2.25, 10a 1.80..... | 4 05 | ...Onhanger |
| 48..... | 6A 3.15, 10a 2.45..... | 5 60 | ...Onioneyed |

Old Style Cond. No. 40. c

| | | | |
|------------|----------|------|---------------|
| 10 Pt..... | 36A..... | 2 35 | ...Opaque |
| 12..... | 30A..... | 2 50 | ...Opaqueness |
| 14..... | 22A..... | 2 75 | ...Openeth |
| 16..... | 22A..... | 3 10 | ...Openeyed |
| 18..... | 22A..... | 3 30 | ...Openhanded |
| 20..... | 18A..... | 3 70 | ...Openings |
| 22..... | 16A..... | 3 70 | ...Openly |
| 24..... | 12A..... | 3 50 | ...Openness |
| 30..... | 10A..... | 3 85 | ...Opentide |
| 36..... | 7A..... | 3 60 | ...Openwork |

Old Style Cond. No. 120. E

| | | | |
|-----------|----------|------|---------------|
| 8 Pt..... | 32A..... | 1 25 | ...Oppression |
| 9..... | 24A..... | 1 15 | ...Oppressors |
| 10..... | 24A..... | 1 30 | ...Opprobrium |
| 12..... | 18A..... | 1 35 | ...Opprobry |
| 16..... | 16A..... | 1 55 | ...Oppugn |
| 18..... | 16A..... | 2 00 | ...Oppugnant |
| 20..... | 12A..... | 2 00 | ...Oppugners |
| 24..... | 8A..... | 1 95 | ...Opsimathy |
| 30..... | 8A..... | 2 40 | ...Opsometer |
| 32..... | 6A..... | 2 55 | ...Opsonation |
| 36..... | 5A..... | 2 85 | ...Optable |
| 42..... | 4A..... | 2 75 | ...Optated |

Old Style Cond. No. 122. E

| | | | |
|-----------|-----------------------------|------|---------------|
| 8 Pt..... | 32A 1.15, 64a 1.50..... | 2 65 | ...Optatively |
| 9..... | 24A .95, 48a 1.20..... | 2 15 | ...Optically |
| 10..... | 20A .95, 40a 1.10..... | 2 05 | ...Optician |
| 12..... | 20A 1.6A .90, 32a 1.10..... | 75 | ...Optics |
| 16..... | 16A..... | 2 00 | ...Optigraph |
| 18..... | 10A 1.15, 20a 1.35..... | 80 | ...Optimacy |
| 20..... | 8A 1.20, 16a 1.35..... | 2 50 | ...Optimates |
| 24..... | 8A..... | 90 | ...Optimism |
| 30..... | 6A 1.30, 12a 1.35..... | 2 55 | ...Optimists |
| 36..... | 5A..... | 1 00 | ...Optimity |
| 42..... | 4A 1.80, 8a 1.90..... | 2 65 | ...Optional |
| 48..... | 3A..... | 1 00 | ...Optometers |
| 54..... | 3A 2.50, 11a 2.00..... | 4 50 | ...Optulency |
| 60..... | 4A..... | 1 25 | ...Opulent |
| 66..... | 4A 1.80, 8a 1.90..... | 3 70 | ...Opuntia |
| 72..... | 3A 2.00, 6a 1.85..... | 1 45 | ...Opuscule |
| 78..... | 3A..... | 3 85 | ...Opusculum |
| 84..... | 3A 2.45, 6a 2.35..... | 1 75 | ...Oracle |
| 90..... | 3A..... | 4 80 | ...Oracular |
| 96..... | 3A 2.90, 6a 2.85..... | 2 00 | ...Oracularly |
| 102..... | 3A..... | 5 75 | ...Oraculous |
| 108..... | 3A..... | 2 45 | ...Orally |
| 114..... | 3A 4.05, 6a 3.90..... | 7 95 | ...Orangeade |
| 120..... | 3A..... | 3 50 | ...Orangeman |
| 126..... | 3A 5.50, 5a 4.00..... | 9 50 | ...Orangemusk |
| 132..... | 3A..... | 4 65 | ...Orangery |

Old Style Extended. F

| | | | |
|-----------|-------------------------|------|---------------|
| 6 Pt..... | 24A 1.50, 30a 1.25..... | 2 75 | ...Ordinal |
| 8..... | 20A 1.70, 30a 1.30..... | 3 00 | ...Ordinalism |
| 10..... | 16A..... | 1 00 | ...Ordinary |
| 12..... | 16A 1.70, 22a 1.30..... | 3 00 | ...Ordinance |
| 14..... | 14A 1.90, 22a 1.60..... | 1 25 | ...Orclure |
| 16..... | 14A..... | 3 50 | ...Orclurous |
| 18..... | 14A..... | 1 50 | ...Orcauds |

Old Style Extended—Continued.

Table listing Old Style Extended typefaces with columns for size (Pt.), style (A, B), and price. Includes entries like 18 Pt. 9A \$1.85, 12a \$1.65, \$3 50... Orfgild.

Old Style Italic No. 79.

Table listing Old Style Italic No. 79 typefaces with columns for size (Pt.), style (A), and price. Includes entries like 6 Pt. 25A 1.20, 80a 1.47, 2 67... Ossean.

Old Style Italic No. 83.

Table listing Old Style Italic No. 83 typefaces with columns for size (Pt.), style (A), and price. Includes entries like 6 Pt. 25A .95, 75a 1.45, 2 40... Ornach.

Old Style Latin Condensed.

Table listing Old Style Latin Condensed typefaces with columns for size (Pt.), style (B), and price. Includes entries like 12 Pt. 25A 1.30, 40a 1.15, 2 45... Ostmen.

Old Style No. 43.

Table listing Old Style No. 43 typefaces with columns for size (Pt.), style (C), and price. Includes entries like 12 Pt. 18A 1.95, 2 40... Outbidders.

OLD STYLE No. 79 (sold at Roman prices).

Old Style No. 83.

Table listing Old Style No. 83 typefaces with columns for size (Pt.), style (E), and price. Includes entries like 6 Pt. 30A .95, 150a 3.05, 4 00... Outdazzled.

Old Style Script.

Table listing Old Style Script typefaces with columns for size (Pt.), style (F), and price. Includes entries like 12 Pt. 10A 2.50, 32a 2.50, 5 00... Outnoised.

Old Style Title.

Table listing Old Style Title typefaces with columns for size (Pt.), style (C), and price. Includes entries like 6 Pt. 30A 1.75, 52a 2.00, 3 75... Outtrigger.

Old Style Two-Line.

Table listing Old Style Two-Line typefaces with columns for size (Pt.), style (F), and price. Includes entries like 12 Pt. 16A \$1 50... Outsleeps.

Open Title No. 120.

Table listing Open Title No. 120 typefaces with columns for size (Pt.), style (E), and price. Includes entries like 5 1/2 Pt. 24A \$0.90, 48a \$1.10, 2 00... Outvied.

Ornaments.

Table listing various ornaments with columns for name, style, and price. Includes entries like Apple Blossom, Whole font, 3 00... Overflow.

Table listing Christmas ornaments with columns for name, style, and price. Includes entries like Christmas, Any character except No. 280A in sets of four, 50... No. 280A single, 40... Class. single characters, 6 25... Overgrab.

Table listing Combination, Series K ornaments with columns for name, style, and price. Includes entries like Combination, Series K, per font, 4 50... Overgraced.

Table listing Egyptian, Series A ornaments with columns for name, style, and price. Includes entries like Egyptian, Series A, Whole font, 2 50... Overking.

Table listing Electric ornaments with columns for name, style, and price. Includes entries like Electric, 36 Point, per font, 3 50... Overlactorate.

Table listing Mural ornaments with columns for name, style, and price. Includes entries like Mural, each, .15, four of each, 50... No. 292A, 30... Palmetto, per font, 1 00... Overlate.

Table listing Margin, Series 1 ornaments with columns for name, style, and price. Includes entries like Margin, Series 1, per font, 1 10... Overlavishly.

Table listing Schaeffer ornaments with columns for name, style, and price. Includes entries like Schaeffer, each, .50, per set, 1 00... Overlax.

Table listing Outing ornaments with columns for name, style, and price. Includes entries like Outing, A, 6 Pt. No. 42, 20A, 1 75... Overpester.

Palm Border.

Table listing Palm Border ornaments with columns for name, style, and price. Includes entries like Palm Border, E, Per font, 30 inches, 3 00... Paddock.

Table listing Palo Alto ornaments with columns for name, style, and price. Includes entries like Palo Alto, F, 18 Pt., 8A 2.25, 26a 2.75, 5 00... Painfully.

Parisian Black No. 120. E Palings

Table with 4 columns: Size, Price, Size, Price. Rows include 6 Pt., 8, 10, 12, 18, 24.

Parthenian. E

Table with 4 columns: Size, Price, Size, Price. Rows include 6 Pt., 9, 10, 12, 18, 24, 36, 48, 60, 72.

Pencraft. c

Table with 4 columns: Size, Price, Size, Price. Rows include 12 Pt., 18, 18 No. 2.

Pen Text. d

Table with 4 columns: Size, Price, Size, Price. Rows include 10, 12, 14, 18, 20, 30, 36.

Perforating Rule.

Table with 4 columns: Size, Price, Size, Price. Rows include 2 Pt., 3, Steel.

Perpetual Calendar Logotypes. A

Table with 4 columns: Size, Price, Size, Price. Rows include No. 1, No. 2, No. 3, No. 4.

Philadelphia Lining Gothic. c Parrotry

Table with 4 columns: Size, Price, Size, Price. Rows include 6 Pt., 8, 10, 12, 14, 18, 24, 30, 36, 48.

SERIES No. 700.

Table with 4 columns: Size, Price, Size, Price. Rows include 6 Pt., 8, 10, 12, 14, 18, 24, 30, 36, 48.

SERIES No. 800.

Table with 4 columns: Size, Price, Size, Price. Rows include 6 Pt., 8, 10, 12, 14, 18, 24, 30, 36, 48.

SERIES No. 900.

Table with 4 columns: Size, Price, Size, Price. Rows include 6 Pt., 8, 10, 12, 14, 18.

Philadelphia Lining Gothic—Continued.

Table with 4 columns: Size, Price, Size, Price. Rows include 24 Pt., 30, 36, 48.

SERIES No. 1000.

Table with 4 columns: Size, Price, Size, Price. Rows include 6 Pt., 8, 10, 12, 14, 18, 24, 30, 36, 48.

SERIES No. 1100.

Table with 4 columns: Size, Price, Size, Price. Rows include 6 Pt., 8, 10, 12, 14, 18, 24, 30, 36, 48.

SERIES No. 1200.

Table with 4 columns: Size, Price, Size, Price. Rows include 6 Pt., 8, 10, 12, 14, 18, 24, 30, 36, 48.

SERIES No. 1300.

Table with 4 columns: Size, Price, Size, Price. Rows include 6 Pt., 8, 10, 12, 14, 18, 24, 30, 36, 48.

SERIES No. 1400.

Table with 4 columns: Size, Price, Size, Price. Rows include 6 Pt., 8, 10, 12, 14, 18, 24, 30, 36, 48.

Pica Borders. d

Table with 4 columns: Size, Price, Size, Price. Rows include No. 202, 204, 205, 206, 207, 208, 209, 211, 212, 213, 214, 216, 217, 218, 219, 220, 221, 224, 225, 226, 227, 228, 229, 230.

Pickups. A

Per font.....\$1 75...*Peacock*

Piece Accents. B-F

2 Pt.....per font, 50...*Pectoral*
 4.....75...*Pectorality*
 6.....1 00...*Peculation*
 9.....1 10...*Peculiar*
 12.....1 50...*Peculiarly*
 12.....No. 6.....1 50...*Peculium*
 6.....Shaded No. 150.....25...*Pedagogic*

Piece Fractions. C-E

7 Pt. No. 40.....per font, 5 00...*Peddler*
 6.....120.....per lb., 5 00...*Pedigerous*
 8.....120.....3 60...*Pedigree*
 9.....120.....3 20...*Pediluvy*
 10.....120.....2 80...*Pedimanous*
 11.....120.....2 40...*Pediment*
 12.....120.....2 00...*Pedipalp*

Piece Root Signs. F

8 Pt.....per lb., 1 60...*Pediveme*
 10.....1 30...*Pedlar's*
 16.....1 06...*Pedometer*
 20.....94...*Pedometric*

Pin, Nail and Screw Heads. F

Per font.....75...*Pequan*
 No. 2.....3 00...*Petragians*

Point Combination Borders. D Penetralium

Series A.....per font, 3 00...*Penetrancy*
 Series B.....3 00...*Penetrant*

Pointer Borders. E Penholder

6 Pt. No. 1.....5 feet.....per font, 1 50...*Peninsula*
 6.....2.....5.....1 50...*Penitence*
 6.....3.....5.....1 50...*Penitently*

Pointers. E Penknife

Black.....per font, 1 25...*Penknives*
 Contour.....1 25...*Pennan*
 Shaded.....1 25...*Penmanship*

Polka-Dot Border. E Pennywise

6 Pt.....6 feet.....per font, 1 50...*Pennyworth*
 12.....6.....1 75...*Penock*
 24.....3.....1 65...*Penracks*

Polo. C Pentaspast

18 Pt.....10A \$1.70, 20a \$1.85.. 3 55...*Pentastich*
 24.....8A 2.05, 16a 2.30.. 4 35...*Pentastyle*
 36.....5A 2.80, 10a 3.10.. 5 90...*Pentateuch*
 48.....4A 3.80, 6a 3.40.. 7 20...*Pentecost*
 60.....3A 5.25, 5a 4.05.. 9 30...*Pentelican*

Porson Greek. A Penthouse

8 Pt.....Job font, 7 50...*Pentremite*
 10.....7 50...*Pentrough*
 11.....7 50...*Penult*
 12.....7 50...*Penultima*

Poster Fonts.

POSTER ANTIQUE No. 125. Perduetism

10 Pt.....72A 4.45, 240a 8.80.. 13 25...*Perdurably*
 12.....54A 4.70, 180a 7.45.. 12 15...*Perdurancer*
 18.....24A 4.20, 96a 9.30.. 13 50...*Peregal*
 24.....16A 3.90, 64a 9.50.. 13 40...*Peregrine*
 30.....12A 5.30, 36a 8.70.. 14 00...*Perempt*
 36.....5A 3.40, 20a 7.60.. 11 00...*Peremptory*

POSTER DE VINNE. Perennial

6 Pt.....240A 9.40, 900a 19.60.. 29 00...*Perennity*
 8.....132A 7.50, 540a 15.00.. 22 50...*Perfected*
 10.....100A 5.50, 390a 13.00.. 18 50...*Perfecting*
 12.....64A 5.25, 240a 11.25.. 16 50...*Perfections*
 14.....48A 4.80, 180a 10.00.. 14 80...*Perfectly*
 18.....30A 4.90, 112a 10.10.. 15 00...*Perfidious*
 24.....24A 6.00, 60a 8.00.. 14 00...*Perfidy*
 30.....12A 6.00, 45a 8.00.. 14 00...*Perfixed*
 36.....10A 5.30, 32a 9.70.. 15 00...*Perfixing*

POSTER DE VINNE CONDENSED. Perfiable

12 Pt.....72A 4.60, 264a 9.90.. 14 50...*Perflation*
 14.....48A 4.05, 180a 9.05.. 13 10...*Perfoliate*
 18.....30A 3.85, 128a 9.90.. 13 75...*Perforated*
 24.....16A 3.10, 84a 9.05.. 12 15...*Perforator*
 30.....12A 3.90, 54a 10.10.. 14 00...*Perforce*
 36.....10A 4.75, 40a 10.65.. 15 40...*Performers*

Poster Fonts—Continued.

POSTER DE VINNE EXTRA COND. Performing

12 Pt.....60A \$2.60, 312a \$8.90.. \$11 50...*Performs*
 14.....54A 3.40, 198a 8.00.. 11 40...*Perfricate*
 18.....36A 3.15, 140a 7.90.. 11 05...*Perfume*
 24.....20A 2.80, 96a 8.15.. 10 95...*Perfumery*
 30.....16A 3.50, 60a 8.05.. 11 55...*Perfusions*
 36.....12A 4.15, 48a 9.10.. 13 25...*Perfusive*

POSTER EASTMAN. Pergola

12 Pt.....48A 3.70, 200a 9.50.. 13 20...*Perianth*
 18.....20A 3.70, 96a 9.00.. 12 70...*Periapts*
 24.....16A 3.80, 60a 8.60.. 12 40...*Peribotos*
 30.....12A 4.75, 45a 9.75.. 14 50...*Pericardic*
 36.....5A 3.10, 24a 8.40.. 11 50...*Pericarps*

POSTER FRENCH O. S. EXTENDED. Periclose

12 Pt.....45A 4.35, 180a 9.90.. 14 25...*Pericope*
 18.....24A 4.15, 80a 8.45.. 12 60...*Periculous*
 24.....12A 3.50, 48a 8.30.. 11 80...*Peridox*
 30.....10A 4.35, 40a 10.65.. 15 00...*Peridrome*
 36.....8A 4.90, 32a 10.50.. 15 40...*Perigee*

POSTER IONIC No. 122. Perigeum

12 Pt.....32A 2.90, 160a 8.45.. 11 35...*Perigone*
 18.....20A 3.65, 100a 9.55.. 13 20...*Perigonium*
 24.....16A 4.15, 64a 9.10.. 13 25...*Perigord*
 30.....12A 5.10, 36a 8.60.. 13 70...*Perignous*
 36.....8A 5.10, 24a 7.50.. 12 60...*Perihetium*

POSTER LATIN ANTIQUE No. 120. Perilous

12 Pt.....36A 3.45, 168a 8.95.. 12 40...*Pertinent*
 18.....20A 3.45, 80a 7.65.. 11 10...*Pertly*
 24.....16A 4.15, 64a 9.80.. 13 95...*Pertness*
 30.....12A 5.25, 36a 9.15.. 14 40...*Pertuisane*
 36.....5A 5.40, 24a 8.40.. 13 80...*Perturb*

POSTER LIGHT-FACE No. 158. Perturbate

8 Pt.....72A 4.05, 360a 11.80.. 15 85...*Perturbing*
 10.....48A 3.25, 288a 10.40.. 13 65...*Pertusion*
 12.....40A 3.15, 210a 9.85.. 13 00...*Pertussis*
 18.....30A 4.65, 100a 8.65.. 13 30...*Perukes*
 20.....24A 3.85, 80a 9.75.. 13 60...*Perusal*
 24.....16A 4.45, 60a 9.25.. 13 70...*Peruse*

POSTER O. S. ANTIQUE No. 120. Perusing

6 Pt.....120A 4.35, 624a 14.15.. 18 50...*Pervades*
 8.....80A 3.80, 400a 10.70.. 14 50...*Pervading*
 10.....54A 3.45, 288a 10.00.. 13 45...*Pervase*
 12.....48A 3.95, 192a 8.65.. 12 60...*Perversely*
 18.....24A 3.90, 96a 8.55.. 12 45...*Perversion*
 24.....16A 4.60, 48a 7.80.. 12 40...*Perversity*

POSTER SCHEFFER OLD STYLE. Pervert

12 Pt.....80A 4.60, 320a 10.90.. 15 50...*Perverters*
 15.....54A 4.85, 180a 8.40.. 13 25...*Pervial*
 18.....45A 5.40, 150a 10.10.. 15 50...*Pervially*
 24.....24A 4.35, 90a 9.30.. 13 65...*Pervivacy*
 30.....16A 4.85, 48a 8.40.. 13 25...*Pesade*
 36.....12A 5.50, 27a 6.70.. 12 20...*Pesanted*

“Post” Bands.

Series A, B or C.

6 Pt.....per font, 35...
 8.....35...
 10.....40...
 12.....40...
 14.....50...
 18.....60...
 24.....70...
 30.....80...
 36.....90...
 42.....1 00...
 48.....1 15...

“Post” Old Style Italic. c Petrean

6 Pt.....16A .90, 36a 1.10.. 2 00...*Petrel*
 8.....14A 1.00, 32a 1.25.. 2 25...*Petritic*
 10.....14A 1.10, 32a 1.40.. 2 50...*Petrified*
 12.....10A 1.05, 25a 1.45.. 2 50...*Petrifying*
 14.....9A 1.25, 20a 1.50.. 2 75...*Petrine*
 18.....7A 1.30, 16a 1.70.. 3 00...*Petrinomy*
 24.....5A 1.60, 12a 2.15.. 3 75...*Petrology*
 30.....4A 1.95, 9a 2.30.. 4 25...*Petronels*
 36.....3A 2.50, 6a 2.25.. 4 75...*Petrosal*
 48.....3A 4.25, 5a 3.00.. 7 25...*Petrosilex*
 60.....3A 6.40, 4a 4.10.. 10 50...*Petrous*

"Post" Old Style Roman No. 1. c

| | | |
|-----------|--------------------------------|-------------------|
| 6 Pt..... | 16A \$0.95, 25a \$1.05, \$2 00 | <i>Petticoat</i> |
| 8..... | 16A 1.15, 24a 1.10, 2 25 | <i>Pettifog</i> |
| 10..... | 14A 1.35, 20a 1.15, 2 50 | <i>Pettily</i> |
| 12..... | 14A 1.45, 20a 1.30, 2 75 | <i>Pettishly</i> |
| 14..... | 12A 1.55, 18a 1.45, 3 00 | <i>Pettitocs</i> |
| 18..... | 8A 1.65, 12a 1.60, 3 25 | <i>Pettichup</i> |
| 24..... | 6A 2.05, 9a 1.70, 3 75 | <i>Petticoy</i> |
| 30..... | 4A 2.25, 6a 2.00, 4 25 | <i>Pettynchim</i> |
| 36..... | 3A 3.05, 5a 2.45, 5 50 | <i>Petulaucy</i> |
| 42..... | 3A 4.20, 4a 2.80, 7 00 | <i>Petulant</i> |
| 48..... | 3A 5.05, 4a 3.45, 8 50 | <i>Petulous</i> |
| 54..... | 3A 6.50, 4a 4.25, 10 75 | <i>Petuntze</i> |
| 60..... | 3A 7.00, 4a 4.50, 11 50 | <i>Petworth</i> |
| 72..... | 3A 12.00, 4a 7.00, 19 00 | <i>Petzite</i> |
| | | <i>Peucile</i> |

"Post" Old Style Roman No. 2. c

| | | |
|-----------|--------------------------|-------------------|
| 6 Pt..... | 15A .90, 24a 1.10, 2 00 | <i>Pewfellow</i> |
| 8..... | 14A 1.10, 20a 1.15, 2 25 | <i>Pewits</i> |
| 10..... | 12A 1.25, 18a 1.25, 2 50 | <i>Pewopener</i> |
| 12..... | 12A 1.35, 18a 1.40, 2 75 | <i>Pewler</i> |
| 14..... | 10A 1.45, 15a 1.55, 3 00 | <i>Pewtever</i> |
| 18..... | 7A 1.50, 10a 1.75, 3 25 | <i>Pezity</i> |
| 24..... | 5A 1.75, 8a 1.75, 3 50 | <i>Peziza</i> |
| 30..... | 4A 2.25, 6a 2.25, 4 50 | <i>Pezizoid</i> |
| 36..... | 3A 3.10, 5a 2.65, 5 75 | <i>Phacas</i> |
| 42..... | 3A 4.20, 4a 3.30, 7 50 | <i>Phacolate</i> |
| 48..... | 3A 5.30, 4a 4.20, 9 50 | <i>Phaeton</i> |
| 54..... | 3A 6.50, 4a 4.75, 11 25 | <i>Phagudena</i> |
| 60..... | 3A 7.00, 4a 6.00, 13 00 | <i>Phagudenic</i> |
| 72..... | 3A 11.65, 4a 8.35, 20 00 | <i>Phalangian</i> |

"Post" Ornaments. c

| | |
|--------------------|-------------|
| No. 1..... | 40... |
| 2 to No. 6..... | each, 35... |
| 7 to No. 9..... | each, 50... |
| 10..... | 40... |
| 11..... | 45... |
| 12 and No. 13..... | each, 40... |
| 14..... | 35... |
| 15 and No. 16..... | each, 45... |
| 17..... | 75... |
| 18..... | 60... |
| 19..... | 40... |
| 20..... | 60... |
| 21 and No. 22..... | each, 50... |
| 23 and No. 24..... | each, 40... |
| 25 and No. 26..... | each, 60... |
| 27..... | 50... |
| 28 and No. 29..... | each, 40... |
| 30 to No. 32..... | each, 50... |
| 33 to No. 35..... | each, 35... |
| 36 and No. 37..... | each, 40... |
| 38..... | 50... |
| 39..... | 40... |
| 40..... | 45... |
| 41..... | 35... |
| 42..... | 50... |
| 43..... | 45... |
| 44 to No. 47..... | each, 40... |
| 48 to No. 58..... | each, 35... |
| 59 to No. 61..... | each, 40... |
| 62..... | 35... |
| 63..... | 40... |
| 64 and No. 65..... | each, 35... |
| 66..... | 30... |
| 67 to No. 69..... | each, 40... |
| 70 to No. 72..... | each, 35... |
| 73..... | 40... |
| 74..... | 35... |
| 75..... | 30... |
| 76 and No. 77..... | each, 35... |
| 78..... | 30... |
| 79 to No. 81..... | each, 35... |
| 82 and No. 83..... | each, 40... |
| 84..... | 50... |
| 85..... | 40... |
| 86..... | 60... |
| 87..... | 35... |
| 88..... | 40... |
| 89..... | 35... |
| 90..... | 40... |
| 91..... | 50... |
| 92..... | 40... |
| 93..... | 50... |

"Post" Ornaments—Continued.

| | |
|----------------------|-------------|
| No. 94..... | \$0 35... |
| 95..... | 45... |
| 96 to No. 99..... | each, 40... |
| 100..... | 35... |
| 101 to No. 103..... | each, 40... |
| 104..... | 35... |
| 105..... | 40... |
| 106..... | 30... |
| 107..... | 35... |
| 108..... | 30... |
| 109 and No. 110..... | each, 25... |
| 111..... | 75... |
| 112..... | 50... |
| 113..... | 60... |
| 114..... | 40... |
| 115..... | 50... |
| 116..... | 40... |
| 117 and No. 118..... | each, 50... |
| 119..... | 40... |
| 120 and No. 121..... | each, 50... |
| 122..... | 60... |
| 123..... | 50... |
| 124..... | 45... |
| 125 and No. 126..... | each, 50... |
| 127..... | 60... |
| 128..... | 50... |
| 129..... | 35... |
| 130 to No. 132..... | each, 40... |
| 133 and No. 134..... | each, 35... |
| 135 and No. 136..... | each, 45... |
| 137..... | 40... |
| 138 and No. 139..... | each, 35... |
| 140 to No. 142..... | each, 40... |
| 151 to No. 166..... | each, 60... |
| 167 to No. 182..... | each, 50... |
| 183 to No. 198..... | each, 40... |

Primrose Borders. H

| | | |
|------------|------------------|-----------------------|
| 12 Pt..... | .36 inches, 1 75 | <i>Penumbra</i> |
| 18..... | .36..... | 2 00 <i>Penurious</i> |
| 24..... | .36..... | 2 65 <i>Penury</i> |
| | | 2 65 <i>Penwoman</i> |

Printers' Nic-Nacs. E

| | | |
|---------------|------|-----------------|
| Per font..... | 1 00 | <i>Phalaris</i> |
|---------------|------|-----------------|

Priory Text. A

| | | |
|------------------|--------------------------------|-------------------|
| 8 Pt. No. 1..... | 16A \$1.25, 44a \$1.75, 3 00 | <i>Philippic</i> |
| 10..... | 1.....16A 1.52, 40a 1.90, 3 42 | <i>Philippine</i> |
| 12..... | 1.....12A 1.22, 32a 1.86, 3 08 | <i>Philister</i> |
| 12..... | 2.....8A 1.30, 24a 1.89, 3 19 | <i>Philistine</i> |
| 14..... | 1.....8A 1.40, 24a 2.24, 3 64 | <i>Philogyny</i> |
| 18..... | 2.....8A 1.75, 20a 2.25, 4 00 | <i>Philologer</i> |
| 24..... | 2.....6A 2.25, 15a 2.00, 4 25 | <i>Philomath</i> |
| 30..... | 2.....6A 2.70, 10a 2.30, 5 00 | <i>Philomela</i> |
| 36..... | 2.....5A 3.25, 8a 2.75, 6 00 | <i>Philopena</i> |

Quaint. A

| | | | |
|-----------|----------|------|--------------------|
| 8 Pt..... | 24A..... | 1 90 | <i>Quackery</i> |
| 10..... | 20A..... | 1 90 | <i>Quacking</i> |
| 12..... | 14A..... | 1 90 | <i>Quackish</i> |
| 18..... | 10A..... | 2 25 | <i>Quackles</i> |
| 24..... | 8A..... | 2 90 | <i>Quadra</i> |
| 36..... | 6A..... | 3 40 | <i>Quadrangene</i> |
| 48..... | 4A..... | 4 00 | <i>Quadrangle</i> |
| | | 4 00 | <i>Quadrant</i> |

Quaint Open. A

| | | | |
|-----------|----------|------|-------------------|
| 8 Pt..... | 24A..... | 1 90 | <i>Quandary</i> |
| 10..... | 20A..... | 1 90 | <i>Quantic</i> |
| 12..... | 14A..... | 1 90 | <i>Quantitive</i> |
| 18..... | 10A..... | 2 25 | <i>Quantum</i> |
| 24..... | 8A..... | 2 90 | <i>Quarantine</i> |
| 36..... | 6A..... | 3 40 | <i>Quarrel</i> |
| 48..... | 4A..... | 4 00 | <i>Quarrelers</i> |
| | | 4 00 | <i>Quarreling</i> |

Quaint Roman No. 2. F

| | | |
|------------|--------------------------|-----------------------|
| 10 Pt..... | 14A 2.00, 18a 1.00, 3 00 | <i>Quarterly</i> |
| 12..... | 14A 2.00, 16a 1.25, 3 25 | <i>Quarterternate</i> |
| 18..... | 8A 2.80, 10a 1.70, 4 50 | <i>Quartertrion</i> |
| 24..... | 6A 3.00, 8a 2.00, 5 00 | <i>Quatrain</i> |
| 36..... | 4A 4.40, 6a 4.10, 8 50 | <i>Quatrefoil</i> |
| 48..... | 4A 6.75, 5a 4.25, 11 00 | <i>Quatvor</i> |
| | | <i>Quavers</i> |

| | | | | | | | |
|--------------------|-----|---------|-------------|------------------|---------------------|--|--|
| Quentell. F | | | | Quickness | | | |
| 6 Pt..... | 24A | \$1.10, | 36a \$1.15. | \$2 25... | <i>Quicksands</i> | | |
| 8..... | 22A | 1.30, | 30a 1.20. | 2 50... | <i>Quickstand</i> | | |
| 10..... | 20A | 1.50, | 26a 1.25. | 2 75... | <i>Quickstep</i> | | |
| 12..... | 16A | 1.65, | 20a 1.35. | 3 00... | <i>Quidnunc</i> | | |
| 14..... | 12A | 1.65, | 18a 1.60. | 3 25... | <i>Quiescent</i> | | |
| 18..... | 10A | 1.60, | 16a 1.65. | 3 25... | <i>Quieter</i> | | |
| 24..... | 8A | 2.30, | 10a 1.70. | 4 00... | <i>Quietism</i> | | |
| 30..... | 6A | 2.70, | 9a 2.30. | 5 00... | <i>Quietly</i> | | |
| 36..... | 5A | 3.00, | 8a 2.50. | 5 50... | <i>Quietness</i> | | |
| 42..... | 4A | 3.75, | 6a 3.50. | 7 25... | <i>Quietude</i> | | |
| 48..... | 4A | 4.65, | 5a 3.10. | 7 75... | <i>Quillbit</i> | | |
| 54..... | 4A | 6.00, | 5a 4.25. | 10 25... | <i>Quillesworth</i> | | |
| 60..... | 4A | 7.25, | 5a 5.00. | 12 25... | <i>Quillwort</i> | | |
| 72..... | 4A | 10.00, | 5a 7.00. | 17 00... | <i>Quilted</i> | | |

| | | | | | | | |
|------------------------------|-----------|--|--|-------|------------------|--|--|
| Quentell Fractions. F | | | | | | | |
| 6 Pt..... | per font, | | | 50... | <i>Quinary</i> | | |
| 8..... | | | | 50... | <i>Quinate</i> | | |
| 10..... | | | | 50... | <i>Quinces</i> | | |
| 12..... | | | | 50... | <i>Quinctart</i> | | |
| 14..... | | | | 50... | <i>Quinctree</i> | | |
| 18..... | | | | 50... | <i>Quincwine</i> | | |
| 24..... | | | | 50... | <i>Quincwort</i> | | |
| 30..... | | | | 75... | <i>Quincunx</i> | | |
| 36..... | | | | 75... | <i>Quindism</i> | | |

| | | | | | | | |
|-------------------------|----|-------|-----------|----------------|-------------------|--|--|
| Quincy Script. A | | | | Quinine | | | |
| 24 Pt..... | 5A | 2.15, | 16a 2.10. | 4 25... | <i>Quinoa</i> | | |
| 36..... | 4A | 2.80, | 9a 2.20. | 5 00... | <i>Quinoidine</i> | | |
| 48..... | 3A | 3.75, | 6a 2.25. | 6 00... | <i>Quinivism</i> | | |

| | | | |
|--------------------|---------------------------|--|--|
| Quotations. | | | |
| Per lb..... | 0 25 | | |
| 20 lb. font..... | 5 00... <i>Quit</i> | | |
| 40..... | 10 00... <i>Quitclaim</i> | | |

| | | | | | | | |
|--------------------|-------------|--|--|---------------|-------------------|--|--|
| Rabbinic. B | | | | Rabbit | | | |
| 8 Pt..... | 8-lb. font, | | | 12 80... | <i>Rabbeted</i> | | |
| 10..... | 8..... | | | 10 40... | <i>Rabbetical</i> | | |
| 12..... | 10..... | | | 11 60... | <i>Rabbits</i> | | |

| | | | | | | | |
|------------------|-----|-------|-----------|---------------|-------------------|--|--|
| Ramona. F | | | | Raffle | | | |
| 18 Pt..... | 10A | 2.25, | 32a 2.25. | 4 50... | <i>Rafflenet</i> | | |
| 24..... | 8A | 2.55, | 20a 2.05. | 4 60... | <i>Rafflesia</i> | | |
| 30..... | 6A | 2.85, | 14a 1.90. | 4 75... | <i>Raftbridge</i> | | |

| | | | | | | | |
|-------------------|-----|-------|-----------|----------------|-----------------|--|--|
| Raphael. F | | | | Rageous | | | |
| 18 Pt..... | 10A | 1.75, | 15a 1.50. | 3 25... | <i>Ragery</i> | | |
| 24..... | 6A | 2.30, | 8a 1.70. | 4 00... | <i>Ragfair</i> | | |
| 36..... | 4A | 3.15, | 6a 2.35. | 5 50... | <i>Raggedly</i> | | |

| | | | | | | | |
|---------------------|----|-------|-----------|-----------------|-------------------|--|--|
| Recherche. C | | | | Recalled | | | |
| 18 Pt..... | 8A | 1.00, | 30a 1.45. | 2 45... | <i>Recalling</i> | | |
| 24..... | 7A | 1.20, | 25a 1.70. | 2 90... | <i>Recallment</i> | | |
| 30..... | 6A | 1.60, | 20a 1.90. | 3 50... | <i>Recanted</i> | | |
| 36..... | 5A | 1.90, | 12a 2.10. | 4 00... | <i>Recanting</i> | | |

| | | | | | | | |
|--------------------------------------|-----------|--|--|---------|-------------------|--|--|
| Red, White and Blue Border. H | | | | | | | |
| 18 Pt..... | per font, | | | 5 30... | <i>Refutatory</i> | | |

| | | | | | | | |
|-------------------------|------------|--|--|-----------------|------------------|--|--|
| Regal Borders. H | | | | Regained | | | |
| 12 Pt..... | 36 inches, | | | 1 75... | <i>Regaining</i> | | |
| 12..... | No. 2..... | | | 1 75... | <i>Regales</i> | | |
| 18..... | | | | 2 00... | <i>Regalia</i> | | |
| 18..... | No. 2..... | | | 2 00... | <i>Regaling</i> | | |
| 24..... | | | | 2 65... | <i>Regally</i> | | |
| 24..... | No. 2..... | | | 2 65... | <i>Regard</i> | | |

| | | | | | | | |
|------------------------|-----|-------|-----------|-------------------|-------------------|--|--|
| Regal Italic. F | | | | Regardable | | | |
| 6 Pt..... | 24A | 1.25, | 48a 1.25. | 2 50... | <i>Regardant</i> | | |
| 8..... | 18A | 1.50, | 36a 1.50. | 3 00... | <i>Regarded</i> | | |
| 10..... | 14A | 1.75, | 28a 1.75. | 3 50... | <i>Regardful</i> | | |
| 12..... | 12A | 2.00, | 24a 2.00. | 4 00... | <i>Regarding</i> | | |
| 14..... | 9A | 2.00, | 18a 2.20. | 4 20... | <i>Regardless</i> | | |
| 18..... | 7A | 2.25, | 14a 2.25. | 4 50... | <i>Regathered</i> | | |
| 24..... | 6A | 2.50, | 12a 2.75. | 5 25... | <i>Regeney</i> | | |
| 30..... | 5A | 2.80, | 10a 3.20. | 6 00... | <i>Regentbird</i> | | |
| 36..... | 4A | 3.25, | 8a 3.25. | 6 50... | <i>Regicidal</i> | | |

| | | | | | | | |
|------------------------------|-----|-------|------------|---------|---------------|--|--|
| Remington Standard. E | | | | | | | |
| 12 Pt..... | 20A | 2.00, | 110a 5.25. | 7 25... | <i>Rarely</i> | | |

RENATE INITIALS (see Initials).

| | | | | | | | |
|-------------------------|----|---------|-------------|----------------|----------------|--|--|
| Revere Script. A | | | | Rawhide | | | |
| 24 Pt..... | 7A | \$4.00, | 27a \$4.00. | \$8 00... | <i>Rawness</i> | | |
| 36..... | 5A | 5.00, | 18a 5.00. | 10 00... | <i>Rayless</i> | | |
| 48..... | 4A | 6.00, | 15a 6.00. | 12 00... | <i>Razed</i> | | |

| | | | | | | | |
|------------------------------------|----------|--|--|-----------------|--|--|--|
| Reversible Metal Furniture. | | | | | | | |
| 25-lb. font..... | 6 25... | | | <i>Readept</i> | | | |
| 50..... | 12 50... | | | <i>Reader</i> | | | |
| 75..... | 18 75... | | | <i>Readiest</i> | | | |
| 100..... | 25 00... | | | <i>Readily</i> | | | |

| | | | | | | | |
|--------------------------|---------|--|--|------------------|--|--|--|
| Rigs and Traps. F | | | | | | | |
| Per font..... | 1 50... | | | <i>Readiness</i> | | | |

| | | | | | | | |
|-------------------|-----|-------|-----------|-----------------|-------------------|--|--|
| Rimpled. C | | | | Realized | | | |
| 8 Pt..... | 25A | 1.25, | 40a 1.25. | 2 50... | <i>Realizing</i> | | |
| 10..... | 22A | 1.45, | 35a 1.30. | 2 75... | <i>Realleged</i> | | |
| 12..... | 20A | 1.70, | 30a 1.30. | 3 00... | <i>Really</i> | | |
| 18..... | 12A | 1.75, | 18a 1.50. | 3 25... | <i>Realms</i> | | |
| 24..... | 8A | 1.90, | 12a 1.60. | 3 50... | <i>Realness</i> | | |
| 30..... | 6A | 2.40, | 9a 1.85. | 4 25... | <i>Reanimate</i> | | |
| 36..... | 5A | 2.75, | 8a 2.25. | 5 00... | <i>Reannezed</i> | | |
| 48..... | 4A | 3.85, | 6a 3.15. | 7 00... | <i>Reannezing</i> | | |

| | | | | | | | |
|-------------------------|---------|--|--|-------------------|--|--|--|
| Rococo Border. F | | | | | | | |
| Per font..... | 2 50... | | | <i>Reappoints</i> | | | |

| | | | | | | | |
|---------------------------------|---------|--|--|-------------------|--|--|--|
| Rogers Embellishments. A | | | | | | | |
| Complete assortment..... | 3 00... | | | <i>Reapproach</i> | | | |

ROMAN BODY-TYPE (see Price List on page xv; also code words for ordering on pages 1183 and 1184).

| | | | | | | | |
|----------------------|----------|-------|-----------|-------------------|-------------------|-------------------|--|
| Romanesque. F | | | | Rediminish | | | |
| 6 Pt. No. 153..... | 20A | 1.00, | 20A 1.25. | 2 25... | <i>Redisburse</i> | | |
| 6..... | 152..... | 20A | 1.00, | 20A 1.25. | 2 25... | <i>Rediscover</i> | |
| 6..... | 151..... | 20A | 1.00, | 20A 1.25. | 2 25... | <i>Redisposed</i> | |
| 8..... | 150..... | 18A | .90, | 18A 1.10. | 2 00... | <i>Redissolve</i> | |
| 10..... | 150..... | 16A | 1.10, | 16A 1.40. | 2 50... | <i>Redivide</i> | |
| 12..... | 150..... | 14A | 1.25, | 14A 1.75. | 3 00... | <i>Redividing</i> | |
| 18..... | 150..... | 10A | 1.50, | 10A 2.00. | 3 50... | <i>Redlac</i> | |
| 24..... | 150..... | 6A | 1.60, | 6A 2.40. | 4 00... | <i>Redletter</i> | |
| 30..... | 150..... | 5A | 2.20, | 5A 2.90. | 5 10... | <i>Redolency</i> | |

| | | | | | | | |
|----------------------------------|-----|-------|-----------|----------------|-------------------|--|--|
| Roman Extended No. 120. E | | | | Redoubt | | | |
| 5 Pt..... | 24A | 1.60, | 48a 1.80. | 3 40... | <i>Redounding</i> | | |
| 5 Pt. on 6 Pt..... | 24A | 1.30, | 48a 1.40. | 2 70... | <i>Redounds</i> | | |
| 5 1/2..... | 24A | 1.45, | 48a 1.60. | 3 05... | <i>Redova</i> | | |
| 6..... | 18A | 1.15, | 36a 1.15. | 2 30... | <i>Redpole</i> | | |
| 8..... | 18A | 1.45, | 36a 1.60. | 3 05... | <i>Redraft</i> | | |
| 9..... | 16A | 1.30, | 32a 1.45. | 2 75... | <i>Redrawing</i> | | |
| 10..... | 12A | 1.25, | 24a 1.25. | 2 50... | <i>Redress</i> | | |
| 12..... | 12A | 1.80, | 24a 1.90. | 3 70... | <i>Redressers</i> | | |
| 18..... | 8A | 2.55, | 16a 2.55. | 5 10... | <i>Redressing</i> | | |
| 24..... | 6A | 2.60, | 12a 2.80. | 5 40... | <i>Redriven</i> | | |
| 30..... | 5A | 2.85, | 10a 3.00. | 5 85... | <i>Redroot</i> | | |
| 36..... | 4A | 4.50, | 8a 4.25. | 8 75... | <i>Redsanders</i> | | |

| | | | | | | | |
|------------------------|----|-------|----------|---------|------------------|--|--|
| Roman No. 44. C | | | | | | | |
| 60 Pt..... | 4A | 6.05, | 4a 2.90. | 8 95... | <i>Redseared</i> | | |

| | | | | | | | |
|-----------------------------------|-------------|--|--|-------|-----------------|--|--|
| Roman No. 120 Fractions. E | | | | | | | |
| 24 Pt..... | 1-lb. font, | | | 56... | <i>Redshank</i> | | |
| 30..... | | | | 56... | <i>Redshare</i> | | |
| 48..... | | | | 54... | <i>Redshort</i> | | |

| | | | | | | | |
|-----------------------|-----|-------|-----------|---------|----------------|--|--|
| Roman Slope. A | | | | | | | |
| 12 Pt..... | 10A | 1.45, | 32a 1.55. | 3 00... | <i>Reenact</i> | | |

| | | | | | | | |
|--|-----|-------|-----------|---------|-------------------|---------|--------------------|
| Ronaldson O. S. No. 72. Reenacted | | | | | | | |
| 15 Pt..... | 6A, | 12A | | 40a | | 4 55... | <i>Reenactedly</i> |
| 18..... | 14A | 2.00, | 30a 2.30. | 4 30... | <i>Reenacting</i> | | |
| 24..... | 10A | 2.25, | 20a 2.45. | 4 70... | <i>Reenadowed</i> | | |
| 30..... | 8A | 2.75, | 16a 3.10. | 5 85... | <i>Reendowing</i> | | |
| 36..... | 6A | 3.40, | 12a 3.60. | 7 00... | <i>Reengaged</i> | | |
| 48..... | 5A | 4.20, | 8a 3.80. | 8 00... | <i>Reengaging</i> | | |

| | | | | | |
|-------------------------------|-------------------------|----------------------------|------------------|--|--|
| Ronaldson Clarendon. c | | | <i>Reenstamp</i> | | |
| 6 Pt..... | 36A \$1.60, 70a \$1.75. | \$3 35... <i>Reentered</i> | | | |
| 8..... | 30A 1.65, 60a 1.80. | 3 45... <i>Reentering</i> | | | |
| 10..... | 25A 1.65, 50a 1.90. | 3 55... <i>Reenthrone</i> | | | |
| 12..... | 22A 1.80, 45a 2.15. | 3 95... <i>Reentrance</i> | | | |
| 18..... | 14A 2.20, 28a 2.45. | 4 65... <i>Reentry</i> | | | |
| 24..... | 10A 2.35, 20a 2.65. | 5 00... <i>Reerect</i> | | | |
| 30..... | 8A 2.70, 16a 3.35. | 6 05... <i>Reexamine</i> | | | |
| 36..... | 6A 3.50, 10a 3.50. | 7 00... <i>Reexhibit</i> | | | |
| 48..... | 5A 4.25, 8a 4.10. | 8 35... <i>Reexpel</i> | | | |

| | | | | | |
|-------------------------------|---------------------|---------------------------|-------------------|--|--|
| Ronaldson Condensed. c | | | <i>Reexpelled</i> | | |
| 6 Pt..... | 36A 1.10, 70a 1.40. | 2 50... <i>Reexported</i> | | | |
| 8..... | 30A 1.10, 60a 1.40. | 2 50... <i>Refashions</i> | | | |
| 10..... | 26A 1.15, 52a 1.40. | 2 55... <i>Refastened</i> | | | |
| 12..... | 22A 1.20, 45a 1.50. | 2 70... <i>Referable</i> | | | |
| 18..... | 14A 1.40, 28a 1.75. | 3 15... <i>References</i> | | | |
| 24..... | 10A 1.70, 18a 1.90. | 3 60... <i>Referreth</i> | | | |
| 30..... | 8A 1.90, 14a 2.25. | 4 15... <i>Refilled</i> | | | |
| 36..... | 7A 2.40, 12a 2.85. | 5 25... <i>Refinedly</i> | | | |
| 48..... | 5A 2.95, 8a 2.95. | 5 90... <i>Refinement</i> | | | |

| | | | | | |
|------------------------------|---------------------|---------------------------|-----------------|--|--|
| Ronaldson Extended. c | | | <i>Refiners</i> | | |
| 6 Pt..... | 25A 1.25, 40a 1.20. | 2 45... <i>Reflectent</i> | | | |
| 8..... | 22A 1.45, 32a 1.25. | 2 70... <i>Reflecting</i> | | | |
| 10..... | 20A 1.55, 30a 1.45. | 3 00... <i>Reflective</i> | | | |
| 12..... | 18A 1.85, 28a 1.65. | 3 50... <i>Reflectors</i> | | | |
| 18..... | 10A 2.05, 16a 1.95. | 4 00... <i>Reflex</i> | | | |
| 24..... | 8A 2.35, 12a 2.30. | 4 65... <i>Reflexible</i> | | | |
| 30..... | 6A 2.70, 10a 2.70. | 5 40... <i>Refourish</i> | | | |
| 36..... | 5A 3.30, 8a 3.25. | 6 55... <i>Refowed</i> | | | |
| 48..... | 4A 4.45, 6a 4.00. | 8 45... <i>Refuency</i> | | | |

| | | | | | |
|----------------------------|---------------------|---------------------------|-----------------|--|--|
| Ronaldson Gothic. c | | | <i>Refluent</i> | | |
| 6 Pt..... | 40A 1.50, 60a 1.60. | 3 10... <i>Reformed</i> | | | |
| 8..... | 38A 1.55, 55a 1.55. | 3 10... <i>Reform</i> | | | |
| 10..... | 28A 1.50, 45a 1.60. | 3 10... <i>Reformado</i> | | | |
| 12..... | 22A 1.55, 34a 1.55. | 3 10... <i>Reformers</i> | | | |
| 14..... | 18A 1.55, 28a 1.60. | 3 15... <i>Reforming</i> | | | |
| 18..... | 12A 1.55, 18a 1.60. | 3 15... <i>Refortify</i> | | | |
| 24..... | 10A 1.80, 15a 1.90. | 3 70... <i>Refossion</i> | | | |
| 30..... | 8A 2.40, 12a 2.55. | 4 95... <i>Refounders</i> | | | |
| 36..... | 6A 2.90, 9a 2.90. | 5 80... <i>Refracted</i> | | | |
| 48..... | 5A 3.65, 7a 3.50. | 7 15... <i>Refraction</i> | | | |

| | | | | | |
|---------------------------------|---------------------|---------------------------|-------------------|--|--|
| Ronaldson Title Slope. c | | | <i>Refractory</i> | | |
| 6 Pt..... | 30A 1.40, 60a 1.60. | 3 00... <i>Refragable</i> | | | |
| 8..... | 25A 1.50, 50a 1.65. | 3 15... <i>Refrain</i> | | | |
| 10..... | 22A 1.60, 45a 1.75. | 3 35... <i>Refraineth</i> | | | |
| 12..... | 20A 1.75, 40a 1.80. | 3 55... <i>Refraining</i> | | | |
| 18..... | 12A 2.05, 22a 2.10. | 4 15... <i>Reframed</i> | | | |
| 24..... | 8A 2.25, 14a 2.25. | 4 50... <i>Refresh</i> | | | |
| 30..... | 6A 2.80, 10a 2.45. | 5 25... <i>Refresheth</i> | | | |
| 36..... | 5A 3.25, 8a 2.75. | 6 00... <i>Refreshful</i> | | | |

| | | | | | |
|-----------------------------|-----------------|---------------------------|----------------|--|--|
| Round Corner Rule. E | | | <i>Regrede</i> | | |
| 2 Pt..... | 3-lb. font..... | 6 00... <i>Regressed</i> | | | |
| 4..... | 3-lb. font..... | 5 25... <i>Regression</i> | | | |
| 6..... | 5-lb. font..... | 8 75... <i>Regret</i> | | | |

| | | | | | |
|-----------------------------|------------------|-------------------------|------------------|--|--|
| EXTRA CORNER PIECES. | | | <i>Regretful</i> | | |
| 2 Pt..... | per set of four, | 50... <i>Regretted</i> | | | |
| 4..... | | 50... <i>Regretting</i> | | | |
| 6..... | | 50... <i>Reguerdon</i> | | | |

| | | |
|--------------------|-------|-------------------------|
| Rounders. E | | |
| Per font..... | | 1 50... <i>Refuseth</i> |

| | | | | | |
|------------------------|---------------------|----------------------------|------------------|--|--|
| Round Gothic. c | | | <i>Reinduced</i> | | |
| 6 Pt..... | 52A 1.55, 70a 1.15. | 2 70... <i>Reinducing</i> | | | |
| 7..... | 36A 1.25, 70a 1.40. | 2 65... <i>Reinfected</i> | | | |
| 8..... | 36A 1.35, 70a 1.50. | 2 85... <i>Reinforced</i> | | | |
| 10..... | 36A 1.45, 52a 1.30. | 2 75... <i>Reinfunds</i> | | | |
| 11..... | 36A 1.60, 52a 1.55. | 3 15... <i>Reinfused</i> | | | |
| 12..... | 22A 1.50, 42a 1.55. | 3 05... <i>Reinhabit</i> | | | |
| 14..... | 22A 1.70, 42a 2.00. | 3 70... <i>Reinquire</i> | | | |
| 18..... | 18A 1.90, 28a 1.90. | 3 80... <i>Reinserted</i> | | | |
| 22..... | 18A 2.80, 24a 2.35. | 5 15... <i>Reinspire</i> | | | |
| 24..... | 14A 2.90, 20a 2.60. | 5 50... <i>Reinspirit</i> | | | |
| 30..... | 12A 3.35, 18a 3.35. | 6 70... <i>Reinstall</i> | | | |
| 36..... | 10A 4.60, 14a 3.10. | 7 70... <i>Reinstated</i> | | | |
| 48..... | 7A 6.65, 10a 5.05. | 11 70... <i>Reinstruct</i> | | | |
| 60..... | 5A 7.10, 8a 5.20. | 12 30... <i>Reinterred</i> | | | |
| 72..... | 5A 6a | 17 50... <i>Reimundate</i> | | | |

| | | | | | |
|---------------------|-------------------------|----------------------------|------------------|--|--|
| Roundhead. c | | | <i>Rejective</i> | | |
| 9 Pt..... | 14A \$1.05, 20a \$0.95. | \$2 00... <i>Rejoiceth</i> | | | |
| 12..... | 12A 1.15, 16a 1.10. | 2 25... <i>Rejoicings</i> | | | |
| 18..... | 10A 1.75, 12a 1.40. | 3 15... <i>Rejoin</i> | | | |
| 24..... | 8A 2.00, 10a 1.70. | 3 70... <i>Rejoinder</i> | | | |
| 36..... | 4A 2.50, 5a 1.95. | 4 45... <i>Rejoining</i> | | | |
| 48..... | 3A 3.30, 4a 2.50. | 5 80... <i>Rejoined</i> | | | |

| | | | | | |
|------------------------|---------------------|---------------------------|------------------|--|--|
| Royal Gothic. E | | | <i>Reliquary</i> | | |
| 6 Pt..... | 24A 1.05, 48a 1.20. | 2 25... <i>Reliques</i> | | | |
| 8..... | 24A 1.35, 48a 1.70. | 3 05... <i>Relishable</i> | | | |
| 10..... | 18A 1.25, 36a 1.45. | 2 70... <i>Relished</i> | | | |
| 12..... | 16A 1.45, 32a 1.70. | 3 15... <i>Relishing</i> | | | |
| 18..... | 10A 1.45, 20a 1.70. | 3 15... <i>Relocated.</i> | | | |
| 20..... | 10A 2.20, 20a 2.60. | 4 80... <i>Relocate</i> | | | |
| 24..... | 8A 2.25, 16a 2.80. | 5 05... <i>Relocation</i> | | | |
| 30..... | 6A 2.40, 12a 2.85. | 5 25... <i>Relucant</i> | | | |
| 36..... | 5A 3.20, 10a 3.85. | 7 05... <i>Reluctancy</i> | | | |
| 48..... | 4A 4.25, 8a 4.70. | 8 95... <i>Reluctant</i> | | | |

| | | | | | |
|------------------------|--------------------------|---------------------------|-----------------|--|--|
| Royal Script. F | | | <i>Remanent</i> | | |
| 10 Pt..... | 10A 2.25, 32a 2.25. | 4 50... <i>Remark</i> | | | |
| 12..... | 10A 2.50, 32a 2.50. | 5 00... <i>Remarkable</i> | | | |
| | 5A 1.50, 16a 1.50. | 3 00... <i>Remarkers</i> | | | |
| 18..... | 8A 3.00, 24a 3.00. | 6 00... <i>Remarking</i> | | | |
| | 4A 1.60, 12a 1.90. | 3 50... <i>Remarriage</i> | | | |
| 24..... | No. 1 8A 3.90, 20a 3.60. | 7 50... <i>Remarrying</i> | | | |
| | 4A 2.25, 10a 2.25. | 4 50... <i>Remasted</i> | | | |
| 24..... | 2 8A 3.90, 22a 3.60. | 7 50... <i>Remeant</i> | | | |
| | 4A 2.25, 12a 2.25. | 4 50... <i>Remeasure</i> | | | |
| 30..... | 1 7A 4.50, 20a 4.50. | 9 00... <i>Remediable</i> | | | |
| | 4A 2.65, 10a 2.35. | 5 00... <i>Remedies</i> | | | |
| 30..... | 2 7A 4.50, 24a 4.50. | 9 00... <i>Remediless</i> | | | |
| | 4A 2.65, 12a 2.35. | 5 00... <i>Remedy</i> | | | |

| | | | | | |
|------------------|---------------------|---------------------------|------------------|--|--|
| Rubens. A | | | <i>Remissful</i> | | |
| 12 Pt..... | 22A 1.55, 36a 1.45. | 3 00... <i>Remissions</i> | | | |
| 18..... | 12A 1.45, 24a 1.80. | 3 25... <i>Remissive</i> | | | |
| 24..... | 12A 2.25, 18a 2.00. | 4 25... <i>Remissly</i> | | | |
| 30..... | 10A 2.35, 14a 2.15. | 4 50... <i>Remissness</i> | | | |
| 36..... | 8A 2.65, 12a 2.35. | 5 00... <i>Remissory</i> | | | |
| 42..... | 7A 3.00, 10a 2.50. | 5 50... <i>Remittent</i> | | | |
| 48..... | 6A 3.35, 8a 2.65. | 6 00... <i>Remitters</i> | | | |
| 54..... | 6A 3.75, 8a 3.00. | 6 75... <i>Remixed</i> | | | |
| 60..... | 4A 3.75, 7a 3.75. | 7 50... <i>Remixing</i> | | | |
| 72..... | 5A 5.75, 6a 4.50. | 10 25... <i>Remnants</i> | | | |

RULE ORNAMENTS (see Ornaments).

| | | | | | |
|-----------------------------------|--------------------|---------------------------|-------------------|--|--|
| Runic Condensed No. 120. E | | | <i>Reparation</i> | | |
| 10 Pt..... | 18A .85, 36a 1.10. | 1 95... <i>Reparel</i> | | | |
| 12..... | 12A .75, 24a 1.05. | 1 80... <i>Repartee</i> | | | |
| 14..... | 10A .90, 20a 1.15. | 2 05... <i>Repassage</i> | | | |
| 18..... | 8A 1.10, 16a 1.50. | 2 60... <i>Repassed</i> | | | |
| 24..... | 6A 1.20, 12a 1.60. | 2 80... <i>Repassing</i> | | | |
| 30..... | 5A 1.50, 10a 1.90. | 3 40... <i>Repasture</i> | | | |
| 42..... | 4A 2.10, 8a 2.50. | 4 60... <i>Repatriate</i> | | | |
| 48..... | 3A 3.05, 6a 3.05. | 6 10... <i>Repayable</i> | | | |
| 60..... | 3A 4.60, 5a 3.65. | 8 25... <i>Repayeth</i> | | | |
| 72..... | 3A 7.00, 5a 5.85. | 12 85... <i>Repaying</i> | | | |

| | | | | | |
|-----------------------------------|-----------|---------------------------|-------------------|--|--|
| Runic Condensed No. 122. E | | | <i>Repayments</i> | | |
| 8 Pt..... | 32A | 1 40... <i>Repealers</i> | | | |
| 10..... | 24A | 1 30... <i>Repedation</i> | | | |
| 12..... | 18A | 1 35... <i>Repellency</i> | | | |
| 16..... | 16A | 1 75... <i>Repelling</i> | | | |
| 20..... | 12A | 2 10... <i>Repentance</i> | | | |
| 24..... | 10A | 2 40... <i>Repentant</i> | | | |
| 36..... | 8A | 3 15... <i>Repenteth</i> | | | |
| 42..... | 6A | 4 05... <i>Repenting</i> | | | |
| 48..... | 4A | 4 05... <i>Repeopled</i> | | | |
| 60..... | 4A | 6 55... <i>Repeopling</i> | | | |

| | | |
|--------------------------|------------------|------------------------|
| Russian No. 10. B | | |
| 12 Pt...Smallest font | 25 lbs...per lb. | 66... <i>Reproving</i> |

| | | |
|------------------------------|----------------------|--------------------------|
| Rustic Band Border. E | | |
| 24 Pt..... | 3 feet.....per font, | 1 65... <i>Repudiate</i> |

| | | | | | |
|-------------------------|---------------------|----------------------------|-------------------|--|--|
| Sansom Script. c | | | <i>Sacredness</i> | | |
| 18 Pt..... | 10A 3.55, 50a 5.75. | 9 30... <i>Sacrificial</i> | | | |
| 24..... | 10A 5.00, 50a 7.50. | 12 50... <i>Sacrificed</i> | | | |
| 36..... | 6A 6.30, 30a 8.70. | 15 00... <i>Sacrilege</i> | | | |

| | | | |
|----------------------|-----|------------------|------------------|
| Santa Cruz. F | | <i>Sailcloth</i> | |
| 12 Pt..... | 30A | \$2 50 | <i>Sailhooks</i> |
| 18..... | 24A | 3 00 | <i>Sailloft</i> |
| 24..... | 18A | 3 75 | <i>Sailmaker</i> |

| | | | |
|--------------------|-------------------------|-------------------|-------------------|
| Satanick. A | | <i>Sailneedle</i> | |
| 6 Pt..... | 15A \$1.15, 50a \$1.35. | 2 50 | <i>Sailor</i> |
| 8..... | 15A 1.25, 50a 1.50. | 2 75 | <i>Sailyard</i> |
| 10..... | 12A 1.40, 40a 1.60. | 3 00 | <i>Sainfoin</i> |
| 12..... | 10A 1.55, 35a 1.70. | 3 25 | <i>Sainthood</i> |
| 18..... | 8A 1.75, 25a 2.25. | 4 00 | <i>Sainlike</i> |
| 24..... | 6A 2.20, 15a 2.30. | 4 50 | <i>Sakaret</i> |
| 30..... | 6A 2.90, 10a 2.10. | 5 00 | <i>Salaam</i> |
| 36..... | 5A 3.20, 8a 2.30. | 5 50 | <i>Salaaming</i> |
| 42..... | 4A 4.15, 6a 3.10. | 7 25 | <i>Salading</i> |
| 48..... | 4A 5.10, 5a 2.65. | 7 75 | <i>Salads</i> |
| 54..... | 4A 6.65, 5a 3.60. | 10 25 | <i>Salatberry</i> |
| 60..... | 4A 8.10, 5a 4.15. | 12 25 | <i>Salamander</i> |
| 72..... | 4A 11.30, 5a 5.70. | 17 00 | <i>Salamstone</i> |

| | | | |
|-------------------------|--------------------|----------------|-------------------|
| Satanick Open. A | | <i>Satisfy</i> | |
| 18 Pt..... | 8A 1.75, 25a 2.25. | 4 00 | <i>Saligot</i> |
| 24..... | 6A 2.20, 15a 2.30. | 4 50 | <i>Salimeter</i> |
| 36..... | 5A 3.20, 8a 2.30. | 5 50 | <i>Salimetry</i> |
| 48..... | 4A 5.10, 5a 2.65. | 7 75 | <i>Satina</i> |
| 60..... | 4A 6.65, 5a 3.60. | 10 25 | <i>Satination</i> |
| 72..... | 4A 8.10, 5a 4.15. | 12 25 | <i>Satine</i> |
| | 4A 11.30, 5a 5.70. | 17 00 | <i>Salinness</i> |

| | | | |
|-------------------------------|---------------------|-------------------|--------------------|
| Schoeffer Old Style. c | | <i>Saliniform</i> | |
| 8 Pt..... | 25A .95, 50a 1.05. | 2 00 | <i>Salinity</i> |
| 10..... | 25A 1.10, 50a 1.15. | 2 25 | <i>Salinometer</i> |
| 12..... | 20A 1.15, 40a 1.35. | 2 50 | <i>Salinometry</i> |
| 15..... | 18A 1.60, 30a 1.40. | 3 00 | <i>Salinous</i> |
| 18..... | 15A 1.80, 25a 1.70. | 3 50 | <i>Salique</i> |
| 24..... | 12A 2.15, 18a 1.85. | 4 00 | <i>Salisburyia</i> |
| 30..... | 8A 2.40, 12a 2.10. | 4 50 | <i>Salite</i> |
| 36..... | 6A 2.75, 9a 2.25. | 5 00 | <i>Salitral</i> |
| 48..... | 4A 3.20, 7a 2.80. | 6 00 | <i>Salivated</i> |
| 60..... | 3A 4.10, 5a 2.90. | 7 00 | <i>Salivating</i> |
| 72..... | 3A 5.40, 4a 3.10. | 8 50 | <i>Salivous</i> |

| | | | |
|------------------------------------|---------|-------------------|-------------------|
| Schoeffer O. S. Initials. c | | <i>Sallenders</i> | |
| 15 Pt..... | 6A..... | 1 50 | <i>Sallow</i> |
| 24..... | 6A..... | 2 50 | <i>Sallyunn</i> |
| 36..... | 4A..... | 3 50 | <i>Sallyport</i> |
| 48..... | 3A..... | 4 00 | <i>Salmagundi</i> |

SCHOEFFER ORNAMENTS (see Ornaments).

| | | | | |
|-----------------------|---------------------|------------------|-------------------|----------------|
| Schwabacher. B | | <i>Salmonoid</i> | | |
| 6 Pt..... | 15A .80, 50a 1.15. | 1 95 | <i>Salmonpeel</i> | |
| 8..... | 15A 1.00, 50a 1.65. | 2 65 | <i>Saloons</i> | |
| 10..... | 12A .90, 40a 1.35. | 2 20 | <i>Salpian</i> | |
| 12..... | 9A 1.00, 30a 1.35. | 2 35 | <i>Salpicon</i> | |
| 14..... | 9A 1.30, 30a 1.90. | 3 20 | <i>Salsilla</i> | |
| 24..... | 5A 1.45, 15a 1.70. | 3 15 | <i>Salsoacid</i> | |
| 30..... | 5A 2.15, 10a 1.70. | 3 85 | <i>Saltant</i> | |
| 36..... | 4A..... | 4 50 | <i>Saltarello</i> | |
| 48..... | 3A..... | 8a..... | 6 95 | <i>Saltcat</i> |

| | | | |
|----------------------------|---------------------|-----------------|-------------------|
| Schwabacher No. 2 F | | <i>Saluters</i> | |
| 8 Pt..... | 14A 1.25, 42a 1.75. | 3 00 | <i>Saluteth</i> |
| 10..... | 10A 1.35, 30a 1.90. | 3 25 | <i>Saluting</i> |
| 12..... | 8A 1.40, 24a 2.10. | 3 50 | <i>Salvatella</i> |
| 14..... | 7A 1.75, 20a 2.00. | 3 75 | <i>Salvific</i> |
| 16..... | 6A 1.60, 18a 2.40. | 4 00 | <i>Salvoes</i> |
| 20..... | 5A 2.00, 15a 3.00. | 5 00 | <i>Samaritan</i> |
| 30..... | 4A 2.75, 10a 3.25. | 6 00 | <i>Samaroid</i> |
| 36..... | 3A 4.00, 8a 3.00. | 7 00 | <i>Sambuke</i> |
| 48..... | 3A 5.40, 8a 6.00. | 11 40 | <i>Samestre</i> |

| | | | |
|---------------------|-----------|------|----------------|
| Scorchers. B | | | |
| Large..... | per font, | 2 50 | <i>Samette</i> |
| Small..... | per font, | 1 50 | <i>Samia</i> |

SCORING RULE (see Brass Scoring Rule).

SCRIPPS SERIES NO. 58 (sold at Roman prices).

| | | | |
|------------------------|---------------------|-----------------|------------------|
| Script No. 9. c | | <i>Sanitary</i> | |
| 12 Pt..... | 12A 1.90, 32a 1.50. | 3 40 | <i>Sanjak</i> |
| 18..... | 12A 2.70, 32a 2.25. | 4 95 | <i>Santatine</i> |
| 22..... | 12A 3.65, 32a 3.05. | 6 70 | <i>Santon</i> |
| 28..... | 8A 4.05, 20a 3.60. | 7 65 | <i>Sapajou</i> |

SCROLL CORNER ORNAMENTS (see Ornaments).

| | | | |
|-------------------------------|-----------|-----------------|-----------------|
| Sectional Calendars. A | | <i>Sarcosis</i> | |
| No. 5..... | per font, | \$2 50 | <i>Sardines</i> |
|6..... | per font, | 3 00 | <i>Sardonic</i> |
|8..... | per font, | 4 00 | <i>Sardonix</i> |

| | | | |
|-----------------------------------|-------------------------|----------------|-------------------|
| Self-Spacing O. S. Bold. B | | <i>Satanic</i> | |
| 6 Pt..... | 30A \$1.50, 50a \$1.50. | 3 00 | <i>Satanical</i> |
| 8..... | 30A 1.60, 50a 1.70. | 3 30 | <i>Satanism</i> |
| 9..... | 28A 1.60, 45a 1.75. | 3 35 | <i>Satchel</i> |
| 10..... | 25A 1.75, 40a 1.75. | 3 50 | <i>Satellites</i> |
| 12..... | 25A 2.00, 38a 2.00. | 4 00 | <i>Sattiated</i> |

| | | | |
|-------------------------------------|----------------|----------------|-------------------|
| Self-Spacing O. S. Italic. B | | <i>Satisfy</i> | |
| 6 Pt. No. 27..... | Circular font, | 7 00 | <i>Satisfying</i> |
| 8..... | 22..... | 5 40 | <i>Satrap</i> |
| 9..... | 28..... | 4 80 | <i>Satrapess</i> |
| 10..... | 24..... | 4 45 | <i>Satrapical</i> |
| 11..... | 25..... | 4 20 | <i>Saturable</i> |
| 12..... | 26..... | 3 95 | <i>Saturants</i> |

| | | | |
|--|-------------|------|-------------------|
| Self-Spacing Piece Fractions. B | | | |
| MODERN ROMAN: | | | |
| 6 Pt. No. 20 1/2..... | per font, | 2 50 | <i>Saucily</i> |
| 7..... | 23 1/2..... | 2 50 | <i>Saucisse</i> |
| 8..... | 18 1/2..... | 2 50 | <i>Saucisson</i> |
| 9..... | 32 1/2..... | 2 50 | <i>Sauterer</i> |
| 10..... | 17 1/2..... | 2 50 | <i>Saurians</i> |
| 11..... | 21 1/2..... | 2 50 | <i>Sausages</i> |
| 12..... | 31 1/2..... | 2 50 | <i>Sauterelle</i> |

| | | | |
|-------------------|-----------|------|-------------------|
| OLD STYLE ROMAN: | | | |
| 6 Pt. No. 27..... | per font, | 2 50 | <i>Sauciness</i> |
| 8..... | 22..... | 2 50 | <i>Sauerkraut</i> |
| 9..... | 28..... | 2 50 | <i>Sauterling</i> |
| 10..... | 24..... | 2 50 | <i>Sauroid</i> |
| 11..... | 25..... | 2 50 | <i>Saussurite</i> |
| 12..... | 26..... | 2 50 | <i>Sauterne</i> |

SHADED PALMETTO ORNAMENTS (see Ornaments).

SHADED POINTERS (see Pointers).

| | | | |
|------------------|----------|----------------|-----------------|
| Shadow. c | | <i>Sayings</i> | |
| 12 Pt..... | 16A..... | 2 75 | <i>Scabbard</i> |
| 18..... | 10A..... | 3 40 | <i>Scabby</i> |
| 24..... | 7A..... | 4 00 | <i>Scabious</i> |
| 36..... | 3A..... | 4 60 | <i>Scabwort</i> |

| | | | |
|--------------------------|--------------------|-----------------|-----------------|
| Shepard Script. F | | <i>Scaffold</i> | |
| 18 Pt..... | 8A 1.75, 18a 2.00. | 3 75 | <i>Scaglia</i> |
| 24..... | 6A 2.25, 18a 2.50. | 4 75 | <i>Scalado</i> |
| 36..... | 5A 3.30, 12a 3.45. | 6 75 | <i>Scalario</i> |
| 48..... | 4A 4.20, 8a 3.80. | 8 00 | <i>Scalded</i> |

| | | | |
|--------------------|-----------|------|----------------|
| Shoppers. F | | | |
| Per font..... | per font, | 1 50 | <i>Scalene</i> |

| | | | |
|------------------|---------------------|-----------------|-------------------|
| Signet. E | | <i>Scansion</i> | |
| 9 Pt..... | 12A .95, 24a 1.15. | 2 10 | <i>Scansores</i> |
| 12..... | 10A 1.40, 20a 1.30. | 2 70 | <i>Scansorial</i> |
| 18..... | 8A 2.00, 16a 1.85. | 3 85 | <i>Scantiest</i> |
| 24..... | 6A 2.30, 12a 2.10. | 4 40 | <i>Scantiness</i> |
| 36..... | 4A 3.85, 8a 2.75. | 6 60 | <i>Scantlings</i> |

| | | | |
|-----------------------|-----------|------|-----------------|
| Silhouettes. A | | | |
| Per font..... | per font, | 1 75 | <i>Scaphism</i> |

SIX POINT BORDERS (see Nonpareil Borders).

SIX POINT BRACES AND DASHES NO. 2 (see Braces).

| | | | |
|---------------------------|-----------|------|---------------|
| Six Point Stars. B | | | |
| Per font..... | per font, | 3 25 | <i>Scapus</i> |

| | | | |
|--------------------------|---------------------|-----------------|------------------|
| Skinner Script. A | | <i>Scorched</i> | |
| 12 Pt..... | 10A 1.55, 28a 1.95. | 3 50 | <i>Scorching</i> |
| 18..... | 7A 1.65, 22a 2.35. | 4 00 | <i>Scordium</i> |

| | | | | |
|------------------|-------------------------|-----------|----------|-------------------|
| Skjald. A | | | | <i>Scoters</i> |
| 8 Pt..... | 18A \$1.90, 32a \$1.10. | \$3 00... | 3 50... | <i>Scotfree</i> |
| 10..... | 16A 2.00, 32a 1.50.. | 3 50... | 4 00... | <i>Scotists</i> |
| 12..... | 14A 2.30, 24a 1.70.. | 4 00... | 5 00... | <i>Scotodinia</i> |
| 18..... | 10A 3.00, 14a 2.00.. | 5 00... | 7 50... | <i>Scotograph</i> |
| 24..... | 8A 3.50, 10a 2.00.. | 5 50... | 8 65... | <i>Scotomy</i> |
| 36..... | 6A 4.50, 8a 3.00.. | 7 50... | 10 35... | <i>Scotscope</i> |
| 48..... | 4A 5.40, 5a 3.25.. | 8 65... | | <i>Scotticism</i> |
| 60..... | 4A 5.90, 5a 4.45.. | 10 35... | | <i>Scoundret</i> |

| | |
|------------------------|-----------------------|
| Slocum Seals. E | |
| Per font..... | 1 50... <i>Screed</i> |

| | |
|------------------------------------|---|
| Smith Premier Typewriter. F | |
| 12 Pt..... | 20A 3.40, 108a 4.10.. 7 50... <i>Scrutiny</i> |
| SPACE RULE (see Brass Space Rule). | |

| | |
|--------------------------|---------------------------------|
| Speaker Series. E | |
| Two characters each..... | per font, 2 50... <i>Seaboy</i> |
| One character each..... | " 1 50... <i>Seabream</i> |

| | |
|---|--|
| Special Figures. C | |
| (Use word in code-word column with word for weight, as given on page 1183). | |
| 5 Pt.... | Two-third..... per lb., 1 80... <i>Seabreeze</i> |
| 5½..... | Five-seventh..... 1 44... <i>Seabristle</i> |
| 6..... | " "..... 1 16... <i>Seabug</i> |
| 6..... | Three-quarter..... 1 16... <i>Seabuilt</i> |
| 7..... | Five-eighth..... 1 00... <i>Seabun</i> |
| 8..... | Two-third..... 90... <i>Seacabbage</i> |

| | |
|---|-------------------------------------|
| Special Fractions. C-F | |
| (Use word in code-word column with word for weight, as given on page 1183). | |
| 5½ Pt. No. 40..... | 1 lb. font, 1 44... <i>Seacap</i> |
| 5½..... | 154..... 1 44... <i>Seafox</i> |
| 6..... | 154..... 1 16... <i>Seafroth</i> |
| 5½..... | 1528..... 1 44... <i>Seage</i> |
| 6..... | 1528..... 1 16... <i>Seagarland</i> |
| 7..... | 1528..... 1 00... <i>Seagirdles</i> |
| 8..... | 1528..... 90... <i>Seagirt</i> |

| | | |
|-----------------------------|------------------------|---------------------------|
| Spencerian Script. C | | <i>Seaholly</i> |
| 16 Pt..... | 18A.....100a 10.80. | 18 30... <i>Seaholm</i> |
| | 9A..... 50a 5.40. | 9 15... <i>Seahorse</i> |
| 22..... | 18A.....100a 15.70. | 27 25... <i>Seahulver</i> |
| | 9A..... 50a 7.85. | 13 65... <i>Seakale</i> |
| 28..... | 16A.....60a 15.00. | 28 75... <i>Seakings</i> |
| | 8A..... 30a 7.50. | 14 40... <i>Sealark</i> |
| 40..... | 10A..... 50a 22.75. | 40 00... <i>Sealed</i> |
| | 5A..... 25a 11.75. | 20 00... <i>Sealeech</i> |
| 60..... | 3A..... 9a..... 17 60. | 60... <i>Sealegs</i> |

| | | |
|-----------------------------------|------------------------------|----------------------------|
| Spencerian Script No. 2. C | | <i>Sealemon</i> |
| 16 Pt...6A 2.40, 18A..... | 100a 10.20. | 20 65... <i>Sealeopard</i> |
| | 3A 1.20, 9A..... 50a 5.10. | 10 35... <i>Sealletter</i> |
| 22..... | 6A 3.30, 18A.....100a 13.50. | 28 05... <i>Sealingwax</i> |
| | 3A 1.65, 9A..... 50a 6.75. | 14 05... <i>Sealouse</i> |
| 28..... | 6A 4.30, 16A..... 60a 14.40. | 32 05... <i>Seamaid</i> |
| | 3A 2.15, 8A..... 30a 7.20. | 16 05... <i>Seamalls</i> |
| 40..... | 4A 5.60, 10A..... 50a 19.50. | 41 50... <i>Seamanship</i> |
| | 2A 2.80, 5A..... 25a 9.75. | 20 75... <i>Seamarge</i> |

| | | |
|--------------------------|------------------------|-----------------------------|
| Spinner Script. E | | <i>Seamblast</i> |
| 12 Pt..... | 15A 3.15, 75a 4.85. | 8 00... <i>Seamew</i> |
| | 6A..... 25a..... 3 25. | 25... <i>Seamless</i> |
| 18..... | 12A 3.60, 60a 6.40. | 10 00... <i>Seamonsster</i> |
| | 6A..... 16a..... 4 35. | 35... <i>Seamoss</i> |
| 24...No. 2..... | 8A 4.00, 60a 8.50. | 12 50... <i>Seamrent</i> |
| | 4A..... 12a..... 4 75. | 75... <i>Seamstress</i> |
| 24..... | 8A 4.00, 50a 8.50. | 12 50... <i>Seanavel</i> |
| | 4A..... 12a..... 4 75. | 75... <i>Seances</i> |
| 32..... | 5A 4.00, 25a 7.75. | 11 75... <i>Seanettle</i> |
| | 3A..... 8a..... 4 80. | 80... <i>Seanymph</i> |

| | | |
|-----------------------------------|-----------------------|--------------------------|
| Standard Lining Antique. E | | <i>Seaplant</i> |
| 6 Pt. No. 1..... | 35A..... 1 25. | 25... <i>Seapools</i> |
| 6..... | 2..... 30A..... 1 25. | 25... <i>Seaport</i> |
| 6..... | 3..... 30A..... 1 25. | 25... <i>Seapudding</i> |
| 6..... | 4..... 30A..... 1 50. | 50... <i>Seapey</i> |
| 6..... | 5..... 30A..... 1 75. | 75... <i>Seaquake</i> |
| 12..... | 1..... 20A..... 2 00. | 00... <i>Search</i> |
| 12..... | 2..... 20A..... 2 30. | 30... <i>Searchable</i> |
| 12..... | 3..... 20A..... 2 80. | 80... <i>Searcher's</i> |
| 18..... | 10A..... 2 70. | 70... <i>Searcheth</i> |
| 24..... | 8A..... 3 40. | 40... <i>Searchcloth</i> |
| 30..... | 6A..... 3 75. | 75... <i>Searedness</i> |

| | |
|-------------------------------|--|
| Standard Typewriter. C | |
| 12 Pt..... | 20A \$1.50, 100a \$5.95.. \$7 45... <i>Searisk</i> |

| | |
|-------------------------------|--------------------------------|
| Steel Cutting Rule. | |
| 2 Pt., soft..... | per foot, 10... <i>Sebacic</i> |
| 2 Pt., hard, unpolished..... | 15... <i>Sebesten</i> |
| 2 Pt., hard and polished..... | 25... <i>Seceancy</i> |
| 3 Pt., soft..... | 15... <i>Seccant</i> |
| 3 Pt., hard and polished..... | 30... <i>Seceders</i> |
| 6 Pt., soft..... | 25... <i>Seceding</i> |
| 6 Pt., hard and polished..... | 50... <i>Secern</i> |

STEEL PERFORATING RULE (see Perforating Rule).

| | | |
|-----------------------------|----------------|-------------------------|
| Steelplate Gothic. C | | <i>Seccrned</i> |
| 12 Pt..... | 12A..... 2 15. | 15... <i>Secernment</i> |
| 18..... | 8A..... 2 45. | 45... <i>Secession</i> |
| 24..... | 7A..... 3 00. | 00... <i>Secinium</i> |
| 36..... | 4A..... 4 10. | 10... <i>Seckel</i> |

| | | |
|-----------------------------|-------------------------------|----------------------------|
| Steelplate Script. F | | <i>Secrecy</i> |
| 12 Pt..... | 10A 2.00, 32a 3.00.. | 5 00... <i>Secret</i> |
| | 5A 1.50, 16a 1.50. | 3 00... <i>Secretary</i> |
| 24..... | No. 1..... 8A 3.50, 22a 3.50. | 7 00... <i>Secreteth</i> |
| | 4A 2.00, 12a 2.00. | 4 00... <i>Secreting</i> |
| 24..... | 2..... 8A 3.50, 28a 3.50. | 7 00... <i>Secretness</i> |
| | 4A 2.00, 14a 2.00. | 4 00... <i>Secretarian</i> |
| 30..... | 1..... 7A 4.50, 20a 4.50. | 9 00... <i>Sectarists</i> |
| | 4A 2.50, 10a 2.50. | 5 00... <i>Sectary</i> |
| 30..... | 2..... 7A 4.50, 25a 4.50. | 9 00... <i>Sections</i> |
| | 4A 2.50, 12a 2.50. | 5 00... <i>Sectists</i> |

| | |
|---------------------------------|-------------------------------|
| Steel Scoring Rule. | |
| 2 Pt., soft..... | per foot, 10... <i>Sector</i> |
| 2 Pt., hard and unpolished..... | 15... <i>Seculity</i> |
| 2 Pt., hard and polished..... | 25... <i>Secularism</i> |
| 3 Pt., soft..... | 15... <i>Secularity</i> |
| 3 Pt., hard and polished..... | 30... <i>Secundine</i> |
| 6 Pt., soft..... | 25... <i>Secundo</i> |
| 6 Pt., hard and polished..... | 50... <i>Securable</i> |

STELLAR ORNAMENTS (see Ornaments).

| | | |
|-------------------|----------------------|---------------------------|
| Stencil. C | | <i>Securely</i> |
| 12 Pt..... | 10A 1.65, 16a 1.65.. | 3 30... <i>Securement</i> |
| 18..... | 7A 2.20, 10a 2.00.. | 4 20... <i>Secureness</i> |
| 24..... | 6A 2.90, 8a 2.30.. | 5 20... <i>Securifer</i> |
| 36..... | 4A 4.20, 6a 3.70.. | 7 90... <i>Securiform</i> |

| | |
|---------------------|--|
| Stenograf. A | |
| 12 Pt..... | 20A 1.80, 60a 2.85.. 4 65... <i>Seedsman</i> |

| | | |
|------------------|---------------------|---------------------------|
| Stylus. C | | <i>Semiannual</i> |
| 9 Pt..... | 12A 1.40, 32a 1.30. | 2 70... <i>Semibreve</i> |
| 12..... | 12A 2.10, 32a 1.80. | 3 90... <i>Semichorus</i> |
| 18..... | 8A 2.75, 20a 2.30. | 5 05... <i>Semicircle</i> |
| 24..... | 6A 3.05, 14a 2.55.. | 5 60... <i>Semicolumn</i> |

| | | |
|------------------------|----------------------|---------------------------|
| Stylus No. 2. C | | <i>Semidalite</i> |
| 12 Pt..... | 12A 2.00, 32a 2.00.. | 4 00... <i>Semidouble</i> |
| 18..... | 8A 2.25, 20a 2.25.. | 4 50... <i>Semifable</i> |
| 24..... | 6A 2.75, 14a 2.25.. | 5 00... <i>Semifloret</i> |

| | |
|------------------------------|--------------------------------------|
| Superior Figures. C-F | |
| 5½ Pt. No. 40..... | per lb., 2 40... <i>Sempervirent</i> |
| 6..... | 150..... 2 00... <i>Sempervive</i> |
| 7..... | 150..... 1 80... <i>Sempiternal</i> |
| 8..... | 150..... 1 60... <i>Sempiternie</i> |
| 9..... | 150..... 1 44... <i>Sempiternity</i> |
| 10..... | 150..... 1 30... <i>Sempster</i> |
| 11..... | 150..... 1 22... <i>Sempstress</i> |
| 12..... | 150..... 1 16... <i>Semuncia</i> |

| | |
|------------------------------|------------------------------------|
| Superior Letters. C-F | |
| 5½ Pt. No. 40..... | per lb., 2 40... <i>Seniority</i> |
| 6..... | 150..... 2 00... <i>Seniors</i> |
| 7..... | 150..... 1 80... <i>Senmights</i> |
| 8..... | 150..... 1 60... <i>Sennit</i> |
| 9..... | 150..... 1 44... <i>Senocular</i> |
| 10..... | 150..... 1 30... <i>Sensations</i> |
| 11..... | 150..... 1 22... <i>Senseless</i> |
| 12..... | 150..... 1 16... <i>Sensible</i> |

Take Slugs.

| | |
|-------------------------------------|-------------|
| Copper Alloy..... | each, 15... |
| Electro—Word, letter or figure..... | 25... |

| | | | | | | | | |
|-----------------------|-----|---------|-----|----------|------------------|-------------------|--|--|
| Taylor Gothic. | | | | A | <i>Semiovale</i> | | | |
| 10 Pt..... | 20A | \$1.90, | 30a | \$1.10. | \$3 00... | <i>Semipagan</i> | | |
| 12..... | 16A | 2.10, | 25a | 1.15.. | 3 25... | <i>Semipedal</i> | | |
| 18..... | 12A | 2.35, | 20a | 1.65.. | 4 00... | <i>Semiproof</i> | | |
| 24..... | 10A | 2.80, | 15a | 1.70.. | 4 50... | <i>Semipure</i> | | |
| 36..... | 5A | 3.35, | 8a | 2.15.. | 5 50... | <i>Semisavage</i> | | |
| 48..... | 4A | 5.10, | 5a | 2.65.. | 7 75... | <i>Semisteel</i> | | |

| | | | | |
|------------------------------|--|----------|-----------|--|
| Time-Table Logotypes. | | E | | |
| 5 Pt..... | | per lb., | \$2 80... | |
| 5½..... | | | 2 40... | |
| 6..... | | | 2 00... | |
| 8..... | | | 1 60... | |
| 12..... | | | 1 16... | |
| 18..... | | | 1 00... | |

| | | | | | | | | |
|---------------------------|----------|-----|--|----------|-------------------|--|--|--|
| Telescopic Gothic. | | | | F | <i>Tamarind</i> | | | |
| 6 Pt. No. 155..... | 30A | | | 1 00... | <i>Tamarisks</i> | | | |
| 6..... | 156..... | 30A | | 1 15... | <i>Tambac</i> | | | |
| 6..... | 157..... | 30A | | 1 60... | <i>Tambour</i> | | | |
| 6..... | 158..... | 30A | | 2 00... | <i>Tambourine</i> | | | |

| | | | | |
|----------------|-----|----------|-----------------|-------------------|
| Tinted. | | C | <i>Texthand</i> | |
| 12 Pt..... | 12A | | 2 15... | <i>Textile</i> |
| 18..... | 8A | | 2 65... | <i>Textman</i> |
| 24..... | 7A | | 3 30... | <i>Textorial</i> |
| 30..... | 5A | | 3 85... | <i>Textual</i> |
| 36..... | 4A | | 4 60... | <i>Textualist</i> |

TENDRIL INITIALS (see Initials).

| | | | | | | | | |
|----------------------|-----|-------|-----|----------|-------------------|-------------------|--|--|
| Teuton Black. | | | | B | <i>Tawdriness</i> | | | |
| 6 Pt..... | 20A | 1.45, | 50a | 1.45.. | 2 90... | <i>Tawdry</i> | | |
| 8..... | 20A | 1.35, | 50a | 1.80.. | 3 15... | <i>Tawniest</i> | | |
| 10..... | 15A | 1.50, | 40a | 1.85.. | 3 35... | <i>Tawinness</i> | | |
| 12..... | 12A | 1.35, | 30a | 1.70.. | 3 05... | <i>Taxability</i> | | |
| 14..... | 12A | 1.75, | 30a | 1.90.. | 3 65... | <i>Taxable</i> | | |
| 18..... | 10A | 2.05, | 25a | 2.35.. | 4 40... | <i>Taxation</i> | | |
| 24..... | 8A | 2.45, | 20a | 2.80.. | 5 25... | <i>Taxcart</i> | | |
| 30..... | 6A | 2.80, | 15a | 3.50.. | 6 30... | <i>Taxfree</i> | | |

| | | | | | | | |
|---------------------|-----|----------|-----------------|----------|---------|-------------------|--|
| Title Black. | | C | <i>Thankful</i> | | | | |
| 6 Pt..... | 10A | \$1.10, | 28a | \$1.40.. | 2 50... | <i>Thankfully</i> | |
| 8..... | 8A | 1.20, | 20a | 1.50.. | 2 70... | <i>Thankless</i> | |
| 10..... | 8A | 1.45, | 20a | 1.40.. | 2 85... | <i>Thatched</i> | |
| 12..... | 7A | 1.50, | 16a | 1.50.. | 3 00... | <i>Thatching</i> | |
| 18..... | 5A | 1.70, | 10a | 1.70.. | 3 40... | <i>Thawed</i> | |
| 24..... | 4A | 2.25, | 8a | 2.20.. | 4 45... | <i>Thawing</i> | |
| 36..... | 3A | 3.20, | 6a | 2.90.. | 6 10... | <i>Theandrie</i> | |

| | | | | | | | | |
|---------------------------|----|-------|-----|----------|-----------------|------------------|--|--|
| Teutonic Extended. | | | | B | <i>Teamwork</i> | | | |
| 14 Pt..... | 8A | 2.15, | 20a | 1.75.. | 3 90... | <i>Teapant</i> | | |
| 22..... | 6A | 2.70, | 15a | 2.25.. | 4 95... | <i>Teapot</i> | | |
| 24..... | 5A | 2.85, | 12a | 2.55.. | 5 40... | <i>Teasaucer</i> | | |

| | | | | | | | |
|--------------------------------|-----|----------|-------------------|--------|----------|-------------------|--|
| Title Expanded No. 120. | | E | <i>Thimbleful</i> | | | | |
| 5½ Pt..... | 24A | 1.65, | 48a | 1.85.. | 3 50... | <i>Thimberig</i> | |
| 5½ Pt. on 6 Pt. 24A | | 1.40, | 48a | 1.65.. | 3 05... | <i>Thimbles</i> | |
| 6..... | 18A | 1.25, | 36a | 1.40.. | 2 65... | <i>Thinkable</i> | |
| 8..... | 18A | 1.50, | 36a | 1.60.. | 3 10... | <i>Thinketh</i> | |
| 9..... | 18A | 1.45, | 36a | 1.65.. | 3 10... | <i>Thinking</i> | |
| 10..... | 12A | 1.20, | 24a | 1.30.. | 2 50... | <i>Thinkingly</i> | |
| 12..... | 10A | 1.40, | 20a | 1.40.. | 2 80... | <i>Thinly</i> | |
| 18..... | 6A | 1.60, | 12a | 1.55.. | 3 15... | <i>Thinner</i> | |
| 20..... | 6A | 2.15, | 12a | 2.20.. | 4 35... | <i>Thinnish</i> | |
| 24..... | 4A | 2.10, | 8a | 2.05.. | 4 15... | <i>Thiridings</i> | |
| 36..... | 3A | 2.90, | 6a | 2.70.. | 5 60... | <i>Thirdly</i> | |
| 42..... | 3A | 4.75, | 5a | 3.85.. | 8 60... | <i>Thirlage</i> | |
| 48..... | 3A | 6.30, | 5a | 5.25.. | 11 55... | <i>Thirst</i> | |

| | | | | | | | | |
|------------------------|-----|-------|-----|----------|------------------|-------------------|--|--|
| Teutonic No. 1. | | | | B | <i>Telephone</i> | | | |
| 6 Pt..... | 20A | 1.70, | 50a | 2.05.. | 3 75... | <i>Telephonic</i> | | |
| 8..... | 20A | 2.20, | 50a | 2.60.. | 4 80... | <i>Telescope</i> | | |
| 9..... | 15A | 2.30, | 40a | 2.00.. | 4 30... | <i>Telesia</i> | | |
| 10..... | 15A | 2.20, | 40a | 2.65.. | 4 85... | <i>Telesmatic</i> | | |
| 12..... | 12A | 2.25, | 30a | 2.60.. | 4 85... | <i>Telestich</i> | | |
| 14..... | 12A | 3.10, | 30a | 3.30.. | 6 40... | <i>Tellership</i> | | |
| 18..... | 10A | 3.00, | 25a | 3.45.. | 6 45... | <i>Tellina</i> | | |
| 24..... | 8A | 3.60, | 20a | 3.40.. | 7 00... | <i>Tellingly</i> | | |
| 30..... | 6A | 4.50, | 15a | 3.70.. | 8 20... | <i>Tellinite</i> | | |
| 36..... | 5A | 5.35, | 12a | 4.50.. | 9 85... | <i>Telltale</i> | | |

| | | | | | | | | |
|----------------------|----|----------|-----------------|--------|----------|------------------|-------------------|--|
| Title Script. | | E | <i>Thirster</i> | | | | | |
| 24 Pt..... | 8A | 4.40, | 50a | 7.05.. | 11 45... | <i>Thirsteth</i> | | |
| | | 4A | 2.25, | 12a | 1.75.. | 4 00... | <i>Thirstiest</i> | |
| 32..... | 5A | 4.50, | 25a | 6.00.. | 10 50... | <i>Thirstly</i> | | |
| | | 3A | 2.55, | 8a | 2.20.. | 4 75... | <i>Thirsting</i> | |
| 48..... | 4A | 6.80, | 12a | 5.30.. | 12 10... | <i>Thirsty</i> | | |

| | | | | |
|-----------------------------|----------------|-----------|---------|------------------|
| Thirty Point Border. | | | | |
| No. 1..... | 18 inches..... | per font, | 1 50... | <i>Tellurian</i> |

| | | | | | | | |
|-----------------------------------|-----|----------|----------------|--------|---------|-------------------|--|
| Touraine Old Style Italic. | | A | <i>Tollbar</i> | | | | |
| 6 Pt..... | 18A | 1.35, | 40a | 1.15.. | 2 50... | <i>Tollbridge</i> | |
| 8..... | 18A | 1.60, | 36a | 1.15.. | 2 75... | <i>Tollcorn</i> | |
| 10..... | 16A | 1.75, | 32a | 1.25.. | 3 00... | <i>Tolldish</i> | |
| 12..... | 14A | 1.80, | 28a | 1.45.. | 3 25... | <i>Tollgate</i> | |
| 18..... | 10A | 2.20, | 18a | 1.80.. | 4 00... | <i>Tollhop</i> | |
| 24..... | 6A | 2.40, | 12a | 2.10.. | 4 50... | <i>Tomahawk</i> | |
| 30..... | 5A | 2.70, | 10a | 2.30.. | 5 00... | <i>Tomalley</i> | |
| 36..... | 4A | 3.00, | 8a | 2.50.. | 5 50... | <i>Tomato</i> | |
| 42..... | 4A | 4.90, | 5a | 2.35.. | 7 25... | <i>Tombac</i> | |

| | | | | |
|---------------------------------|--------------|-----------|---------|------------------|
| Thirty-six Point Border. | | | | |
| No. 102..... | 10 feet..... | per font, | 8 00... | <i>Testimony</i> |
| | 5 feet..... | " | 4 50... | <i>Testiness</i> |

| | | | | |
|--------------------------|-----|----------|----------------|-----------------|
| Trinal.—Series 1. | | E | <i>Topcoat</i> | |
| 12 Pt..... | 10A | | 2 50... | <i>Topdress</i> |
| 18..... | 8A | | 2 85... | <i>Topers</i> |
| 24..... | 6A | | 3 00... | <i>Topful</i> |

THREE-LINE NONPAREIL BORDERS (see Eighteen Point Borders).

THREE-LINE PICA BORDERS (see Thirty-six Point Borders).

THREE POINT BORDERS (see Half Nonpareil Borders).

| | | | | | | | | |
|---------------------------|----------------|-----------|---------|----------------|--|--|--|--|
| Tiger Lily Border. | | | | E | | | | |
| 36 Pt..... | 30 inches..... | per font, | 2 50... | <i>Testudo</i> | | | | |

| | | | | |
|------------------|----|--|-------------------|------------------|
| Series 2. | | | <i>Tophaceous</i> | |
| 20 Pt..... | 8A | | 3 65... | <i>Tophamper</i> |
| 28..... | 6A | | 4 25... | <i>Topheavy</i> |
| 36..... | 4A | | 4 40... | <i>Tophet</i> |
| Series 3. | | | <i>Topiary</i> | |
| 24 Pt..... | 6A | | 4 40... | <i>Topically</i> |
| 36..... | 4A | | 5 40... | <i>Topknot</i> |
| 48..... | 3A | | 6 25... | <i>Toplight</i> |

| | | | | | | | | |
|---|--|----------|-------|------------------|--|--|--|--|
| Time-Saving Mail List Type. | | | | F | | | | |
| (Use word in code-word column with word for weight, as given on page 1183). | | | | | | | | |
| 10 Pt..... | | per lb., | 46... | <i>Testinoid</i> | | | | |

| | | | | |
|-------------------------|-----------|----------|---------------|-------------------|
| Trinal Initials. | | E | <i>Topmen</i> | |
| 18 Pt..... | 4A | | 1 15... | <i>Topmost</i> |
| 24..... | 3A | | 1 50... | <i>Topography</i> |
| 28..... | Series 2. | 3A | 2 10... | <i>Topping</i> |
| 36..... | 2 | 3A | 2 60... | <i>Toppingly</i> |
| 36..... | 3 | 3A | 3 50... | <i>Toppled</i> |
| 48..... | 3A | | 5 00... | <i>Topsail</i> |

| | | | | | | | | |
|---|-------|----------------|---------|----------|-------------------|--|--|--|
| Time-Table Figures. | | | | F | | | | |
| (Use word in code-word column with word for weight, as given on page 1183). | | | | | | | | |
| 5 Pt. No. | 32, | Heavyface... | per lb. | 1 80... | <i>Tetralpa</i> | | | |
| 5½..... | 32.. | " | | 1 44... | <i>Tetrameter</i> | | | |
| 6..... | 32.. | " | | 1 16... | <i>Tetrandria</i> | | | |
| 7..... | 32.. | " | | 1 00... | <i>Tetraonid</i> | | | |
| 8..... | 32.. | " | | 90... | <i>Tetrapod</i> | | | |
| 5..... | 31, | Lightface..... | | 1 80... | <i>Tetrapote</i> | | | |
| 5½..... | 31.. | " | | 1 44... | <i>Tetrarch</i> | | | |
| 6..... | 31.. | " | | 1 16... | <i>Tetraspore</i> | | | |
| 7..... | 31.. | " | | 1 00... | <i>Tetrastich</i> | | | |
| 8..... | 31.. | " | | 90... | <i>Tetrastyle</i> | | | |
| 6..... | 152, | Whiteface..... | | 3 00... | <i>Tetricity</i> | | | |
| 8..... | 151.. | " | | 1 60... | <i>Tetricous</i> | | | |

| | | | | | | | | |
|------------------------|-----|----------|------------------|--------|---------|-------------------|---------|-------------------|
| Tristan Italic. | | F | <i>Tornadoes</i> | | | | | |
| 8 Pt..... | 12A | 1.60, | 60a | 2.00.. | 3 60... | <i>Torose</i> | | |
| 10..... | 10A | 1.30, | 50a | 2.30.. | 3 60... | <i>Torpedoes</i> | | |
| 12..... | 10A | 1.75, | 50a | 2.60.. | 4 35... | <i>Torpescent</i> | | |
| 18..... | 6A | 1.50, | 6A | 2.00, | 40a | 3.25.. | 6 75... | <i>Torpid</i> |
| | | 6A | | 40a | | | 5 25... | <i>Torpidia</i> |
| 24..... | 5A | 1.90, | 5A | 2.35, | 30a | 3.25.. | 7 50... | <i>Torpidity</i> |
| | | 5A | | 30a | | | 5 60... | <i>Torpidly</i> |
| 30..... | 4A | 1.85, | 4A | 2.50, | 25a | 3.65.. | 8 00... | <i>Torpidness</i> |
| | | 4A | | 25a | | | 6 15... | <i>Torpidy</i> |

| | | | |
|---------------------|--------------------------|-----------|-------------------|
| Tudor Black. | A | | <i>Toryism</i> |
| 6 Pt..... | 15A \$1.00, 50a \$1.25.. | \$2 25... | <i>Tossily</i> |
| 8..... | 15A 1.25, 50a 1.50.. | 2 75... | <i>Tossily</i> |
| 10..... | 12A 1.25, 36a 1.50.. | 2 75... | <i>Tosspot</i> |
| 12..... | 9A 1.00, 30a 1.75.. | 2 75... | <i>Totally</i> |
| 18..... | 8A 1.40, 25a 2.00.. | 3 40... | <i>Totalizing</i> |
| 20..... | 5A 1.50, 15a 2.00.. | 3 50... | <i>Totalness</i> |
| 24..... | 5A 2.15, 15a 2.60.. | 4 75... | <i>Totals</i> |
| 36..... | 4A 2.40, 12a 3.10.. | 5 50... | <i>Totems</i> |
| 42..... | 4A 2.50, 12a 3.50.. | 6 00... | <i>Tottereth</i> |
| 48..... | 5A 4.85, 8a 3.65.. | 8 50... | <i>Tottering</i> |
| 72..... | 3A 7.00, 5a 5.00.. | 12 00... | <i>Tottlish</i> |

TURNER ORNAMENTS (see Ornaments).

| | | | |
|------------------------------|------------|---------|-------------------|
| Twelve Point Borders. | c | | |
| No. 1201..... | 72 inches, | 2 50... | <i>Trajected</i> |
| 1207..... | 72..... | 2 50... | <i>Tralineate</i> |
| 1209..... | 72..... | 2 50... | <i>Tralucent</i> |
| 1220..... | 72..... | 2 50... | <i>Tranation</i> |
| 1225..... | 72..... | 2 50... | <i>Transactor</i> |
| 1227..... | 72..... | 2 50... | <i>Transcribe</i> |
| 1228..... | 72..... | 2 50... | <i>Transcript</i> |
| 1232..... | 72..... | 2 50... | <i>Transezion</i> |
| 1233..... | 72..... | 2 50... | <i>Transflux</i> |
| 1234..... | 73..... | 2 50... | <i>Transflux</i> |

| | | | |
|-----------------------------------|-------------|---------|--------------------|
| Twenty-four Point Borders. | c-d | | |
| No. 200..... | 10 feet, | 5 00... | <i>Transmits</i> |
| | 5..... | 2 75... | <i>Transmittal</i> |
| 201..... | 10..... | 5 00... | <i>Transmobe</i> |
| | 5..... | 2 75... | <i>Transmute</i> |
| 202..... | 10..... | 5 00... | <i>Transmuted</i> |
| | 5..... | 2 75... | <i>Transmutual</i> |
| 2401..... | .66 inches, | 3 50... | <i>Transposal</i> |
| 2402..... | .66..... | 3 50... | <i>Transposed</i> |
| 2403..... | .66..... | 3 50... | <i>Transuded</i> |
| 2404..... | .66..... | 3 50... | <i>Transuding</i> |
| 2405..... | .66..... | 3 50... | <i>Transumpt</i> |
| 2406..... | .66..... | 3 50... | <i>Transverse</i> |

TWENTY-FOURTH INITIALS (see Initials).

| | | | |
|-------------------|----------|--|----------------|
| Twinklers. | e | | |
| Per font..... | 1 00... | | <i>Trapper</i> |

| | | | |
|--------------------------|-----------|---------|-------------------|
| Twinkler Borders. | e | | <i>Trappings</i> |
| 6 Pt. No. 155..... | per font, | 2 60... | <i>Trappists</i> |
| 12.....156..... | | 1 75... | <i>Trappous</i> |
| 12.....157..... | | 1 75... | <i>Traprock</i> |
| 18.....158..... | | 3 10... | <i>Trapstairs</i> |
| 18.....159..... | | 3 10... | <i>Trapstick</i> |
| 18.....160..... | | 3 10... | <i>Traptuft</i> |

TWO-COLOR INITIALS (see Initials).

| | | | |
|-------------------------|----------|---------|--------------------|
| Two-line No. 35. | B | | <i>Treachorous</i> |
| 36 Pt..... | 6A..... | 3 80... | <i>Treachery</i> |
| 42..... | 5A..... | 4 65... | <i>Treachour</i> |
| 48..... | 5A..... | 5 50... | <i>Treadeth</i> |

| | | | |
|--------------------------|----------|---------|-------------------|
| Two-Line No. 124. | e | | <i>Treelouse</i> |
| 9 Pt..... | 24A..... | 1 35... | <i>Treemallow</i> |
| 10..... | 24A..... | 1 55... | <i>Treemoss</i> |
| 11..... | 24A..... | 1 75... | <i>Treenails</i> |
| 12..... | 24A..... | 2 10... | <i>Treesorrel</i> |
| 14..... | 18A..... | 2 20... | <i>Treetoad</i> |
| 16..... | 16A..... | 2 25... | <i>Trefoil</i> |
| 18..... | 12A..... | 2 15... | <i>Trellised</i> |
| 20..... | 12A..... | 2 70... | <i>Trenatode</i> |
| 22..... | 12A..... | 2 80... | <i>Trembled</i> |
| 24..... | 12A..... | 3 40... | <i>Trembling</i> |
| 30..... | 12A..... | 4 50... | <i>Tremella</i> |

| | | | |
|---------------------------------|----------|---------|-------------------|
| Two-Line Letter No. 128. | e | | <i>Tremendous</i> |
| 10 Pt..... | 24A..... | 1 60... | <i>Tremolite</i> |
| 11..... | 24A..... | 1 95... | <i>Tremor</i> |
| 12..... | 24A..... | 2 20... | <i>Tremulant</i> |
| 14..... | 18A..... | 2 20... | <i>Tremulous</i> |
| 16..... | 16A..... | 2 30... | <i>Trenchers</i> |

| | | | |
|--------------------------|----------|---------|-------------------|
| Two-Line No. 129. | e | | <i>Trenchmore</i> |
| 10 Pt..... | 22A..... | 1 50... | <i>Trenchplow</i> |
| 11..... | 16A..... | 1 35... | <i>Trending</i> |
| 12..... | 16A..... | 1 50... | <i>Trends</i> |
| 16..... | 12A..... | 1 50... | <i>Trental</i> |
| 18..... | 12A..... | 1 90... | <i>Trepang</i> |
| 24..... | 8A..... | 2 10... | <i>Trepanize</i> |

| | | | |
|--------------------------|----------|-----------|-------------------|
| Two-Line No. 151. | F | | <i>Trepanners</i> |
| 9 Pt..... | 18A..... | \$1 50... | <i>Trepanning</i> |
| 10..... | 16A..... | 1 50... | <i>Trepegel</i> |
| 12..... | 16A..... | 1 75... | <i>Trephine</i> |
| 14..... | 14A..... | 2 00... | <i>Trephining</i> |
| 16..... | 12A..... | 2 00... | <i>Trescyle</i> |
| 18..... | 11A..... | 2 25... | <i>Trespasses</i> |
| 20..... | 10A..... | 2 50... | <i>Trestles</i> |
| 24..... | 10A..... | 3 00... | <i>Treval</i> |

TWO-LINE PICA BORDERS (see Twenty-four Point Borders).

| | | | |
|--------------------|--------------------------|---------|-------------------|
| Typewriter. | F | | <i>Triseriate</i> |
| 10 Pt..No. 2..... | 18A \$1.50, 85a \$3.50.. | 5 00... | <i>Trismus</i> |
| 12..... | 20A 3.40, 108a 4.10.. | 7 50... | <i>Trispast</i> |
| 14.....No. 2..... | 15A 2.20, 75a 5.30.. | 7 50... | <i>Trispaston</i> |

| | | | |
|--------------|----------------------|---------|-------------------|
| Typo. | c | | <i>Trivial</i> |
| 18 Pt..... | 10A 1.30, 14a 1.10.. | 2 40... | <i>Triviality</i> |
| 24..... | 8A 1.75, 10a 1.10.. | 2 85... | <i>Trivium</i> |
| 30..... | 6A 2.00, 9a 1.55.. | 3 55... | <i>Trocar</i> |
| 36..... | 5A 2.80, 7a 1.90.. | 4 70... | <i>Trochaic</i> |
| 48..... | 4A 2.90, 6a 2.35.. | 5 25... | <i>Trochaical</i> |
| 60..... | 3A 4.20, 4a 2.80.. | 7 00... | <i>Trochanter</i> |

| | | | |
|----------------------------|----------|--|-----------------|
| Typographic Charms. | d | | |
| Per font..... | 6 50... | | <i>Troopers</i> |

| | | | |
|--------------------|----------|---------|----------------|
| Typothetae. | A | | |
| 16 Pt..... | 12A..... | 2 60... | <i>Tugiron</i> |

| | | | |
|----------------------|-------------------------|---------|-----------------|
| Union Border. | H | | |
| 18 Pt..... | 42 inches.....per font, | 2 65... | <i>Unbarred</i> |

| | | | |
|-----------------------|----------------------|---------|-------------------|
| Unique Celtic. | c | | <i>Unbarreled</i> |
| 6 Pt..... | 22A 1.35, 35a 1.15.. | 2 50... | <i>Unbarring</i> |
| 8..... | 20A 1.35, 32a 1.25.. | 2 60... | <i>Unbearing</i> |
| 10..... | 18A 1.60, 28a 1.30.. | 2 90... | <i>Unbecome</i> |
| 12..... | 15A 1.60, 22a 1.40.. | 3 00... | <i>Unbecoming</i> |
| 14..... | 12A 1.75, 18a 1.50.. | 3 25... | <i>Unbegot</i> |
| 18..... | 10A 2.00, 14a 1.60.. | 3 60... | <i>Unbegotten</i> |
| 24..... | 7A 2.25, 10a 1.80.. | 4 05... | <i>Unbeguiled</i> |
| 30..... | 6A 3.15, 8a 2.20.. | 5 35... | <i>Unbehovely</i> |
| 36..... | 4A 3.50, 6a 2.70.. | 6 20... | <i>Unbeknown</i> |

| | | | |
|---------------------------------|----------------------|---------|-------------------|
| Unique Celtic Condensed. | c | | <i>Unbelief</i> |
| 6 Pt..... | 30A 1.05, 45a .95.. | 2 00... | <i>Unbeliever</i> |
| 8..... | 25A 1.25, 38a 1.00.. | 2 25... | <i>Unbendeth</i> |
| 10..... | 20A 1.25, 34a 1.25.. | 2 50... | <i>Unbending</i> |
| 12..... | 18A 1.35, 30a 1.40.. | 2 75... | <i>Unbends</i> |
| 18..... | 12A 1.70, 16a 1.30.. | 3 00... | <i>Unbenign</i> |
| 24..... | 8A 1.90, 10a 1.35.. | 3 25... | <i>Unbetidens</i> |
| 30..... | 6A 2.25, 8a 1.50.. | 3 75... | <i>Unbeware</i> |
| 36..... | 4A 2.35, 6a 1.90.. | 4 25... | <i>Unbewitch</i> |

| | | | |
|--------------------|----------------------|---------|-------------------|
| University. | F | | <i>Unblind</i> |
| 8 Pt..... | 20A 1.20, 44a 1.55.. | 2 75... | <i>Unblushing</i> |
| 10..... | 16A 1.25, 36a 1.50.. | 2 75... | <i>Unbodied</i> |
| 12..... | 12A 1.35, 28a 1.65.. | 3 00... | <i>Unbolted</i> |
| 18..... | 9A 1.50, 20a 2.00.. | 3 50... | <i>Unbolting</i> |

| | | | |
|----------------------------|----------|---------|------------------|
| U. S. Signal Flags. | B | | <i>Uncivic</i> |
| 24 Pt..... | per set, | 1 00... | <i>Uncivilly</i> |
| 36..... | | 1 25... | <i>Unclasped</i> |

| | | | |
|---------------------|---------------------------|----------|-------------------|
| Venetian. | e | | <i>Undated</i> |
| 10 Pt. No. 120..... | 24A 2.00, 140a 6.10.. | 8 10... | <i>Undaunted</i> |
| | 12A 1.00, 70a 3.05.. | 4 05... | <i>Undeadly</i> |
| 12..... | 122 20A 2.20, 100a 4.30.. | 6 50... | <i>Undeceive</i> |
| | 10A 1.10, 50a 2.15.. | 3 25... | <i>Undecisive</i> |
| 12..... | 121 20A 2.00, 100a 4.10.. | 6 10... | <i>Undecked</i> |
| | 10A 1.00, 50a 2.05.. | 3 05... | <i>Undefended</i> |
| 18..... | 121 20A 3.50, 100a 8.50.. | 12 00... | <i>Undeftled</i> |
| | 10A 1.75, 50a 4.25.. | 6 00... | <i>Undeniable</i> |
| 18..... | 122 20A 3.80, 100a 8.50.. | 12 30... | <i>Underactor</i> |
| | 10A 1.90, 50a 4.25.. | 6 15... | <i>Underage</i> |

| | | | |
|--------------------------|----------------------|---------|-------------------|
| Vertical Writing. | A | | <i>Unsettled</i> |
| 8 Pt..... | 18A 1.30, 50a 1.95.. | 3 25... | <i>Unsettling</i> |
| 10..... | 12A 1.50, 40a 2.00.. | 3 50... | <i>Unsezed</i> |
| 12..... | 10A 1.60, 35a 2.40.. | 4 00... | <i>Unsezing</i> |
| 18..... | 8A 1.75, 25a 3.00.. | 4 75... | <i>Unshackle</i> |
| 24..... | 7A 2.00, 22a 4.00.. | 6 00... | <i>Unshakable</i> |
| 36..... | 5A 3.25, 15a 5.75.. | 9 00... | <i>Unshape</i> |

| | | | |
|--------------------|-----|--------|-------------------|
| Victoria. F | | | <i>Unshirled</i> |
| 6 Pt. | 36A | \$2 25 | <i>Unshorn</i> |
| 8 | 28A | 2 50 | <i>Unshroud</i> |
| 10 | 20A | 2 75 | <i>Unslightly</i> |
| 12 | 16A | 3 00 | <i>Unsilky</i> |
| 14 | 12A | 3 25 | <i>Unsinneith</i> |
| 18 | 10A | 3 50 | <i>Unsitting</i> |
| 24 | 8A | 4 50 | <i>Unskilled</i> |
| 30 | 7A | 5 00 | <i>Unskillful</i> |
| 36 | 6A | 6 75 | <i>Unslng</i> |
| 42 | 6A | 7 25 | <i>Unsluiced</i> |
| 48 | 5A | 8 50 | <i>Unsociably</i> |

| | | | |
|---------------------------|-----|------|-------------------|
| Victoria Italic. F | | | <i>Unstinted</i> |
| 6 Pt. No. 1 | 30A | 2 50 | <i>Unstitched</i> |
| 6 | 2 | 2 25 | <i>Unstocked</i> |
| 6 | 3 | 2 00 | <i>Unstocking</i> |
| 6 | 4 | 2 00 | <i>Unstop</i> |
| 6 | 5 | 2 00 | <i>Unstopped</i> |
| 12 | 1 | 2 50 | <i>Unstopping</i> |
| 12 | 2 | 2 25 | <i>Unstrength</i> |
| 12 | 3 | 2 00 | <i>Unstrung</i> |
| 18 | 1 | 3 25 | <i>Unstudied</i> |
| 18 | 2 | 2 75 | <i>Unsuccess</i> |
| 24 | 1 | 3 75 | <i>Unsuitable</i> |
| 24 | 2 | 3 25 | <i>Unsuited</i> |

| | | | |
|------------------|-------------------------|------|-------------------|
| Virile. A | | | <i>Unveiling</i> |
| 12 Pt. | 16A \$1.60, 30a \$1.40. | 3 00 | <i>Unverified</i> |
| 18 | 12A 1.75, 20a 1.75. | 3 50 | <i>Unvigilant</i> |
| 24 | 10A 2.20, 16a 1.80. | 4 00 | <i>Unvoted</i> |
| 30 | 8A 3.00, 12a 2.50. | 5 50 | <i>Unvoweled</i> |
| 36 | 6A 3.25, 10a 2.75. | 6 00 | <i>Unwarily</i> |
| 48 | 6A 3.75, 8a 2.75. | 6 50 | <i>Unwariness</i> |
| 60 | 4A 4.25, 6a 3.25. | 7 50 | <i>Unwarlike</i> |

| | | | |
|-----------------------|---------------------|------|-------------------|
| Virile Open. A | | | <i>Volition</i> |
| 12 Pt. | 16A 1.60, 30a 1.40. | 3 00 | <i>Volitional</i> |
| 18 | 12A 1.75, 20a 1.75. | 3 50 | <i>Volitive</i> |
| 24 | 10A 2.20, 16a 1.80. | 4 00 | <i>Volleying</i> |
| 30 | 8A 3.00, 12a 2.50. | 5 50 | <i>Volower</i> |
| 36 | 6A 3.25, 10a 2.75. | 6 00 | <i>Voltaic</i> |
| 48 | 6A 3.75, 8a 2.75. | 6 50 | <i>Voltameter</i> |
| 60 | 4A 4.25, 6a 3.25. | 7 50 | <i>Voltaplast</i> |

| | | | |
|------------------|--------------------|------|-------------------|
| Walton. E | | | <i>Warrant</i> |
| 18 Pt. | 8A 1.35, 16a 1.50. | 2 85 | <i>Warranters</i> |
| 24 | 6A 1.55, 12a 1.60. | 3 15 | <i>Warranting</i> |
| 30 | 5A 1.80, 10a 1.85. | 3 65 | <i>Warrener</i> |
| 36 | 4A 2.20, 8a 1.95. | 4 15 | <i>Warrior</i> |

| | | | |
|----------------------|---------------------|-------|-------------------|
| Washington. F | | | <i>Waterbug</i> |
| 6 Pt. | 22A 1.20, 32a 1.05. | 2 25 | <i>Waterbutts</i> |
| 8 | 18A 1.40, 24a 1.10. | 2 50 | <i>Watercart</i> |
| 10 | 16A 1.50, 22a 1.25. | 2 75 | <i>Waterclock</i> |
| 12 | 12A 1.60, 18a 1.40. | 3 00 | <i>Watercocks</i> |
| 18 | 9A 1.90, 13a 1.60. | 3 50 | <i>Watercolor</i> |
| 24 | 8A 2.60, 10a 1.90. | 4 50 | <i>Watercraft</i> |
| 30 | 6A 2.90, 8a 2.35. | 5 25 | <i>Watercraze</i> |
| 36 | 5A 4.00, 8a 2.75. | 6 75 | <i>Watercress</i> |
| 42 | 4A 3.75, 6a 3.50. | 7 25 | <i>Watercrow</i> |
| 48 | 4A 6.00, 5a 4.00. | 10 00 | <i>Watercure</i> |
| 54 | 4A 6.10, 5a 4.40. | 10 50 | <i>Waterdeck</i> |
| 60 | 4A 9.20, 5a 5.80. | 15 00 | <i>Waterdog</i> |

WAVERLEY INITIALS (see Initials).

| | | | |
|----------------------------|-----------------------|-------|-------------------|
| Waverly Circular. E | | | <i>Watermole</i> |
| 8 Pt. | 40A 3.60, 160a 7.25. | 10 85 | <i>Waterneut</i> |
| | 14A 1.40, 30a 1.60. | 3 00 | <i>Waterousel</i> |
| 10 | 36A 4.10, 150a 9.75. | 13 85 | <i>Waterplant</i> |
| | 12A 1.50, 24a 1.60. | 3 10 | <i>Waterpoise</i> |
| 12 | 30A 3.90, 140a 10.35. | 14 25 | <i>Waterpots</i> |
| | 10A 1.45, 20a 1.55. | 3 00 | <i>Waterproof</i> |

| | | | |
|----------------------------------|--|--------------|--|
| Wayside Embellishments. A | | | |
| 4339A to 4341A | | each \$0 60 | |
| 4342A | | 50 | |
| 4343A | | 60 | |
| 4345A and 4346A | | each, 75 | |
| 4347A | | 1 00 | |
| 4350A | | 60 | |
| 4351A and 4352A | | each, 75 | |
| 4469A and 4470A | | each, 50 | |
| 4471A | | 1 00 | |
| 4472A | | 60 | |
| 4189C | | each, 50 | |
| | | per pair, 85 | |

WAYSIDE INITIALS (see Initials).

| | | | |
|-----------------------------|--|----------|--|
| Wayside Ornaments. A | | | |
| 317A to 320A | | each, 30 | |
| 323A | | 30 | |
| 325A to 328A | | each, 30 | |
| 330A | | 30 | |
| 333A | | 30 | |
| 335A | | 50 | |
| 336A to 338A | | each, 30 | |
| 340A and 341A | | each, 50 | |
| 346A and 347A | | each, 30 | |
| 350A | | 30 | |
| 354A | | 30 | |
| 355A | | 30 | |
| 358A | | 30 | |
| 360A and 361A | | each, 20 | |
| 366A | | 25 | |
| 371A | | 30 | |
| 372A | | 25 | |
| 373A and 374A | | each, 15 | |
| 385A and 387A | | each, 30 | |
| 388A and 389A | | each, 20 | |
| 390A and 391A | | each, 20 | |
| 393A and 394A | | each, 30 | |
| 406A | | 20 | |
| 409A and 410A | | each, 20 | |
| 416A to 418A | | each, 20 | |
| 420A and 421A | | each, 20 | |
| 422A | | 15 | |
| 423A to 425A | | each, 20 | |
| 431A and 432A | | each, 20 | |
| 435A | | 20 | |

| | | | |
|------------------------------|-----------|----------------|-------------------|
| Weather Indicators. C | | | |
| 36 Pt. | each, .15 | per font, 1 75 | <i>Waterspout</i> |

| | | | |
|-------------------|-------------------------|------|-------------------|
| Webster. A | | | <i>Watery</i> |
| 10 Pt. | 16A \$1.50, 22a \$1.25. | 2 75 | <i>Wattlebird</i> |
| 12 | 12A 1.60, 22a 1.40. | 3 00 | <i>Wattled</i> |
| 18 | 8A 1.70, 14a 1.55. | 3 25 | <i>Waucht</i> |
| 24 | 6A 2.25, 10a 1.75. | 4 00 | <i>Wavelet</i> |
| 36 | 3A 2.90, 6a 2.10. | 5 00 | <i>Waveline</i> |

| | | | |
|-------------------------|--|---------------|----------------|
| Whist Markers. B | | | |
| 18 Pt. | | per lb., 1 00 | <i>Waybill</i> |

WHITE-FACE FIGURES (see Time-Table Figures).

WILSON SERIES No. 60 (sold at Roman prices).

| | | | |
|-------------------|---------------------|------|-------------------|
| Yonkers. B | | | <i>Wickedly</i> |
| 6 Pt. | 30A 1.05, 50a 1.10. | 2 15 | <i>Wickedness</i> |
| 8 | 25A 1.20, 40a .90. | 2 10 | <i>Wideawake</i> |
| 10 | 20A 1.35, 30a .90. | 2 25 | <i>Widened</i> |
| 12 | 15A 1.30, 25a 1.00. | 2 30 | <i>Wideness</i> |
| 14 | 10A 1.35, 20a .95. | 2 30 | <i>Widening</i> |
| 24 | 8A 1.95, 15a 1.50. | 3 45 | <i>Widest</i> |
| 30 | 5A 2.10, 10a 1.75. | 3 85 | <i>Widgeon</i> |
| 36 | 4A 2.65, 8a 1.85. | 4 50 | <i>Widowers</i> |
| 48 | 3A 3.20, 8a 3.75. | 6 95 | <i>Widowhood</i> |

| | | | |
|-------------------------|---------------------|------|-----------------|
| Yost Typewriter. | | | <i>Wifehood</i> |
| 10 Pt. | 20A 2.10, 90a 4.65. | 6 75 | <i>Wifely</i> |
| 12 | 20A 1.85, 90a 4.65. | 6 50 | <i>Wigged</i> |

TELEGRAPH CODE FOR BODY-TYPE FONTS

Roman and German Body-Type is put up in fonts of 25, 50 and 100 lbs., or some multiple of these weights. To order a font of body-type, but two words are necessary: one word indicating the series and size (as given below opposite each size of a series) and one word indicating the weight of font desired.

Example:—The use of the words “**Serrature Sheenly**” would indicate that a 25-lb. font of 5 Point Modern Roman Series No. 46 is ordered.

CODE FOR WEIGHT

| | | | | | |
|-----------|------------|-------------|------------|--------------|------------|
| 1 lb..... | Serosity | 20 lbs..... | Serrated | 275 lbs..... | Sessional |
| 2 “..... | Serotine | 25 “..... | Serrature | 300 “..... | Sestetto |
| 3 “..... | Serotinous | 50 “..... | Serricated | 350 “..... | Sestuur |
| 4 “..... | Serpent | 75 “..... | Serricorn | 400 “..... | Setback |
| 5 “..... | Serpentine | 100 “..... | Serrulate | 450 “..... | Sevenscore |
| 6 “..... | Serpentry | 125 “..... | Servable | 500 “..... | Sevensome |
| 7 “..... | Serpigo | 150 “..... | Serval | 600 “..... | Seventhly |
| 8 “..... | Serpolet | 175 “..... | Servantman | 700 “..... | Severally |
| 9 “..... | Serpula | 200 “..... | Sesquisalt | 800 “..... | Severance |
| 10 “..... | Serpulidan | 225 “..... | Sesquitone | 900 “..... | Severely |
| 15 “..... | Serpulites | 250 “..... | Sessile | 1000 “..... | Severeness |

CODE FOR ORDERING MODERN ROMANS

| | | | | | |
|-----------------------------------|------------|--|-------------|-----------------------------------|------------|
| Modern Roman Series No. 46 | | Inland Series No. 56 | | Modern Roman Series No. 65 | |
| 5 Point..... | Sheenly | 5½ Point..... | Shiloh | 5½ Point..... | Shopkeeper |
| 5½ “..... | Sheepberry | 6 “..... | Shindy | 6 “..... | Shoplifter |
| 6 “..... | Sheepbiter | 7 “..... | Shineth | 7 “..... | Shopmaid |
| 7 “..... | Sheepcot | 8 “..... | Shinglers | 8 “..... | Shopmen |
| 8 “..... | Sheepfaced | 9 “..... | Shingling | 9 “..... | Shopping |
| 9 “..... | Sheepfold | 10 “..... | Shining | 10 “..... | Shopshift |
| Modern Roman Series No. 47 | | Modern Roman Series No. 57 | | 11 “..... | Shopwalker |
| 5½ Point..... | Sheephook | 5 Point..... | Shinlogs | Modern Roman Series No. 66 | |
| 6 “..... | Sheepish | 5½ “..... | Shipboard | 5½ Point..... | Shopwoman |
| 7 “..... | Sheepishly | 6 “..... | Shipboys | 6 “..... | Shores |
| 8 “..... | Sheeprun | 7 “..... | Shipbroker | 7 “..... | Shoreward |
| 9 “..... | Sheepseyes | 8 “..... | Shipeanal | 8 “..... | Shorteake |
| 10 “..... | Sheepshank | 9 “..... | Shipholder | Modern Roman Series No. 67 | |
| 11 “..... | Sheepskin | 10 “..... | Shipjoiner | *5 Point..... | Shortdated |
| 12 “..... | Sheepsplit | Wilson Series No. 60 | | 5½ “..... | Shortdrawn |
| Modern Roman Series No. 50 | | 6 Point..... | Shiretown | 6 “..... | Shortened |
| 6 Point..... | Sheeting | 7 “..... | Shirewiek | 7 “..... | Shortening |
| 7 “..... | Sheetpile | 8 “..... | Shirked | 8 “..... | Shortest |
| 8 “..... | Shekels | 9 “..... | Shirking | 9 “..... | Shorthand |
| 9 “..... | Shekinah | 10 “..... | Shirley | 10 “..... | Shortlived |
| 10 “..... | Sheldaple | 11 “..... | Shirtings | 11 “..... | Shortly |
| Modern Roman Series No. 53 | | 12 “..... | Shirts | 12 “..... | Shortness |
| 5½ Point..... | Shepherd | 14 “..... | Shirtseam | 18 “..... | Shotbelt |
| 6 “..... | Shepherdly | 18 “..... | Shittah | Modern Roman Series No. 68 | |
| 7 “..... | Sherbet | American Press Assoc. Ser. No. 61 | | 6 Point..... | Shotlog |
| 8 “..... | Sheriff | 6 Point..... | Shiverspar | 7 “..... | Shotgauge |
| 9 “..... | Sheriffdom | 7 “..... | Shoadpit | 8 “..... | Shotholes |
| Large Face Series No. 54 | | 8 “..... | Shoaliness | Century Roman | |
| 5½ Point..... | Shepherd | 9 “..... | Shoals | 8 Point..... | Shoo |
| 6 “..... | Shepherdly | Modern Roman Series No. 64 | | 9 “..... | Shooldarry |
| 7 “..... | Sherbet | 8 Point..... | Shooteth | 10 “..... | Shoongavel |
| 8 “..... | Sheriff | 9 “..... | Shootingbox | Century Roman No. 2 | |
| 9 “..... | Sheriffdom | 10 “..... | Shootings | 10 Point..... | Shooter |
| Modern Roman Series No. 55 | | 11 “..... | Shootress | | |
| 6 Point..... | Sherris | 12 “..... | Shopbook | | |
| 7 “..... | Shewn | 14 “..... | Shopgirl | | |
| 8 “..... | Shibboleth | | | | |
| 9 “..... | Shield | | | | |
| 10 “..... | Shieldfern | | | | |
| 11 “..... | Shieldless | | | | |
| 12 “..... | Shiftable | | | | |

CODE FOR ORDERING OLD STYLE ROMANS

To be used with Code for Weight, given on page 1183.

| | | |
|---|---|--|
| <p>Caslon Old Style No. 71</p> <p>6 Point.....Showerless 8 "Showery 9 "Showglass 10 "Showiest 11 "Showily 12 "Showiness 14 "Showman</p> <p>Ronaldson Old Style No. 72</p> <p>6 Point.....Shrewdly 7 "Shrewdness 8 "Shrewish 9 "Shrewishly 10 "Shrewmole 11 "Shrewmouse 12 "Shrieked 15 "Shrievalty</p> <p>Old Style Roman No. 73</p> <p>5½ Point.....Shrimpnet 6 "Shrimps 7 "Shrines</p> <p>Binny Old Style No. 77</p> <p>6 Point.....Shrouds 7 "Shrovetide 8 "Shrubbery 9 "Shrubs 10 "Shrugged 11 "Shrugging 12 "Shrunken</p> | <p>Franklin Old Style No. 79</p> <p>5 Point.....Siccific 6 "Siccicy 7 "Sickbed 8 "Sickberth 9 "Sickened 10 "Sickening 11 "Sicker 12 "Sickerly 14 "Sickish</p> <p>Old Style Roman No. 83</p> <p>*5½ Point No. 80...Siestas 6 "Sifleman 7 "Sigaultian 8 "Sigheth 9 "Sighings 10 "Sighted 11 "Sightless 12 "Sightseers</p> <p>Old Style Roman Series No. 84</p> <p>6 Point.....Signalfire 7 "Signalist 8 "Signalized 10 "Signally 11 "Signalment 12 "Signations</p> <p>Old Style Roman Series No. 325</p> <p>6 Point.....Sidebox 7 "Sidecut 8 "Sideglance 9 "Sidelong 10 "Sidepipe 11 "Sideposts 12 "Sideral</p> | <p>Caxton Old Style</p> <p>6 Point.....Sirvente 8 "Sisalgrass 10 "Sisal hemp 12 "Siserary</p> <p>Cushing Series</p> <p>6 Point.....Sisterly 8 "Sistine 10 "Sistrum 12 "Sisymbrium 15 "Sisynopia</p> <p>French Elzevir No. 1</p> <p>8 Point.....Sisyphus 10 "Sitfast 12 "Sithence 14 "Sitiology</p> <p>French Old Style No. 2</p> <p>6 Point.....Situatd 7 "Situation 8 "Sitzbath 10 "Sixfold 12 "Sixthly</p> <p>Cushing Monotone</p> <p>8 Point.....Skindeep 10 "Skinflint 11 "Skinfuls</p> <p>Cushing Monotone No. 2</p> <p>10 Point.....Skipjack</p> |
|---|---|--|

CODE FOR ORDERING SELF SPACING BODY LETTER

To be used with Code for Weight, given on page 1183.

| | | |
|--|---|--|
| <p>Self Spacing Modern Roman</p> <p>No. 17½..10 Point...Sexual No. 18½.. 8 " ..Sexualists No. 19½.. 5½ " ..Sexuality No. 20½.. 6 " ..Shabbiest No. 21½..11 " ..Shabbily No. 23½.. 7 " ..Shacklebar No. 31½..12 " ..Shagreen</p> | <p>Self Spacing Modern Roman</p> <p>No. 32½.. 9 Point...Shakedown No. 34½.. 8 " ..Shakerism No. 36½.. 6 " ..Shakoers No. 37½.. 6 " ..Shallowest No. 38½.. 7 " ..Shallowly No. 48½.. 8 " ..Shallowness</p> | <p>Self Spacing Old Style Roman</p> <p>No. 22.... 8 Point...Shabbiness No. 24....10 " ..Shackled No. 25....11 " ..Shacklock No. 26....12 " ..Shadbush No. 27.... 6 " ..Shaddocks No. 28.... 9 " ..Shaded No. 29....10 " ..Shadeful No. 30.... 6 " ..Shadefully</p> |
|--|---|--|

CODE FOR ORDERING GERMAN BODY LETTER

To be used with Code for Weight, given on page 1183.

| | |
|--|---|
| <p>German Series No. 121</p> <p>6 Point.....Skelder 7 "Skeleton 8 "Skellum 9 "Skeptic 10 "Skeptical 11 "Skepticism 12 "Skerry 14 "Sketch</p> <p>German Series No. 153</p> <p>6 Point.....Skewarch 8 "Skewback 10 "Skewbald 11 "Skewers</p> | <p>German Series No. 155</p> <p>6 Point.....Skidded 8 "Skidding 9 "Skiffs 10 "Skillful 12 "Skillfully</p> <p>Self Spacing German</p> <p>No. 40.....10 Point.....Skyblue No. 41..... 9 "Skycolor No. 42..... 6 "Skyhigh No. 43..... 8 "Skyish</p> |
|--|---|

INDEX AND PRICE LIST OF CUTS

| NO. | PAGE | PRICE | NO. | PAGE | PRICE | NO. | PAGE | PRICE | NO. | PAGE | PRICE |
|--------|------|-------|-------|------|-------|-------|------|-------|--------------------|------|-------|
| 987A | 843 | \$.50 | 3131A | 846 | \$.35 | 4042A | 874 | \$.60 | 78B | 876 | \$.15 |
| 1702A | 833 | .50 | 3132A | 838 | .30 | 4062A | 874 | 1.50 | 79B | 831 | .15 |
| 1750A | 862 | .35 | 3133A | 838 | .40 | 4064A | 874 | .75 | 80B | 831 | .15 |
| 1752A | 862 | .75 | 3135A | 836 | .30 | 4207A | 874 | .60 | 81B | 831 | .15 |
| 1756A | 833 | .50 | 3136A | 836 | .60 | 4210A | 874 | .75 | 82B | 831 | .15 |
| 1850A | 830 | .40 | 3138A | 840 | .30 | 4211A | 874 | .75 | 83B | 831 | .15 |
| 2069A | 843 | .30 | 3139A | 838 | .40 | 4361A | 845 | .60 | 84B | 876 | .15 |
| 2079A | 830 | .35 | 3141A | 840 | .40 | 4362A | 845 | .60 | 85B | 876 | .15 |
| 2241A | 831 | .40 | 3142A | 839 | .40 | 4363A | 845 | .60 | 86B | 876 | .15 |
| 2287A | 834 | .50 | 3143A | 844 | .50 | 4364A | 845 | .60 | 87B | 876 | .15 |
| 2319½A | 839 | .75 | 3144A | 844 | .40 | 4365A | 846 | .60 | 90B | 876 | .15 |
| 2434A | 831 | .75 | 3145A | 844 | .30 | 4366A | 845 | .60 | 92B | 876 | .15 |
| 2438A | 831 | .75 | 3146A | 838 | .50 | 4368A | 845 | .60 | 93B | 876 | .25 |
| 2573A | 833 | .30 | 3147A | 839 | .40 | 4388A | 845 | .75 | 96B | 853 | .25 |
| 2754A | 832 | .50 | 3148A | 839 | .40 | 4389A | 846 | .60 | 98B | 876 | .15 |
| 2766A | 834 | .75 | 3149A | 839 | .50 | 4392A | 846 | .60 | 99B | 876 | .25 |
| 2820A | 836 | .40 | 3150A | 839 | .50 | 4393A | 845 | .60 | 101B | 876 | .25 |
| 2857A | 840 | .60 | 3151A | 839 | .40 | 4394A | 846 | .60 | 104B | 876 | .15 |
| 2882A | 852 | .30 | 3152A | 836 | .75 | 4395A | 845 | .60 | 105B | 876 | .25 |
| 3024A | 831 | .30 | 3153A | 836 | 1.00 | 4396A | 846 | .60 | 106B | 876 | .25 |
| 3027A | 830 | .30 | 3154A | 839 | .75 | 4397A | 846 | .75 | 114B | 876 | .25 |
| 3033A | 832 | .50 | 3155A | 840 | .75 | 4398A | 846 | .65 | 119B | 876 | .25 |
| 3041A | 833 | .40 | 3157A | 836 | .50 | | | | 132B | 852 | .30 |
| 3043A | 833 | .75 | 3159A | 841 | .35 | 1B | 876 | .08 | 161B | 825 | 1.00 |
| 3044A | 830 | .50 | 3160A | 844 | .40 | 8B | 876 | .12 | 163B | 831 | .60 |
| 3050A | 832 | .50 | 3161A | 841 | .50 | 12B | 876 | .12 | Three colors, 1.25 | | |
| 3053A | 833 | .50 | 3163A | 844 | 1.00 | 13B | 876 | .08 | 164B | 831 | .40 |
| 3055A | 832 | .60 | 3166A | 839 | .60 | 14B | 876 | .12 | Three colors, 1.25 | | |
| 3057A | 833 | .50 | 3167A | 840 | .60 | 15B | 876 | .12 | 166B | 830 | .25 |
| 3059A | 830 | .60 | 3169A | 837 | .75 | 20B | 876 | .12 | 168B | 830 | .60 |
| 3060A | 831 | .75 | 3170A | 844 | .50 | 22B | 876 | .12 | 170B | 830 | .25 |
| 3061A | 832 | .50 | 3171A | 837 | .75 | 23B | 876 | .12 | 172B | 830 | .25 |
| 3062A | 833 | .50 | 3172A | 843 | .50 | 24B | 876 | .12 | 173B | 834 | .25 |
| 3064A | 832 | .40 | 3173A | 843 | .75 | 25B | 876 | .25 | 174B | 834 | .60 |
| 3065A | 833 | .35 | 3174A | 843 | .35 | 26B | 876 | .12 | Two colors, 1.20 | | |
| 3066A | 830 | .50 | 3175A | 843 | .40 | 28B | 876 | .08 | 175B | 834 | .75 |
| 3069A | 833 | .50 | 3176A | 840 | .30 | 30B | 876 | .08 | 176B | 834 | .60 |
| 3070A | 833 | .50 | 3177A | 843 | 1.00 | 32B | 876 | .08 | Two colors, 1.20 | | |
| 3072A | 831 | .60 | 3178A | 843 | .50 | 35B | 876 | .12 | 177B | 834 | .25 |
| 3074A | 833 | .50 | 3181A | 838 | .50 | 36B | 876 | .12 | 179B | 834 | .25 |
| 3075A | 833 | .75 | 3184A | 838 | .25 | 37B | 876 | .12 | 180B | 834 | .25 |
| 3077A | 830 | .40 | 3185A | 838 | .60 | 38B | 833 | .12 | 181B | 834 | .40 |
| 3078A | 830 | .60 | 3186A | 837 | .50 | 39B | 876 | .25 | 183B | 836 | .30 |
| 3079A | 830 | .50 | 3189A | 844 | .40 | 40B | 876 | .12 | 184B | 836 | .50 |
| 3081A | 832 | .50 | 3190A | 838 | 1.00 | 41B | 876 | .08 | 185B | 835 | .75 |
| 3083A | 830 | .50 | 3191A | 837 | .40 | 42B | 876 | .12 | 186B | 835 | .75 |
| 3084A | 833 | .60 | 3194A | 844 | .75 | 43B | 876 | .12 | 187B | 835 | .75 |
| 3089A | 836 | .50 | 3196A | 840 | .75 | 44B | 876 | .12 | 188B | 835 | .75 |
| 3092A | 836 | .30 | 3198A | 842 | .60 | 45B | 876 | .08 | Three colors, 2.00 | | |
| 3104A | 834 | .40 | 3200A | 842 | .60 | 53B | 876 | .12 | 190B | 837 | .75 |
| 3109A | 830 | .25 | 3218A | 872 | .60 | 59B | 876 | .12 | 191B | 837 | .40 |
| 3110A | 834 | .30 | 3220A | 872 | .60 | 60B | 876 | .12 | 192B | 836 | .60 |
| 3111A | 834 | .50 | 3321A | 831 | .50 | 61B | 876 | .12 | Four colors, 2.00 | | |
| 3118A | 834 | .50 | 3323A | 830 | .40 | 62B | 876 | .12 | 193B | 824 | .30 |
| 3119A | 834 | .50 | 3325A | 832 | .50 | 65B | 876 | .12 | 196B | 824 | .50 |
| 3121A | 834 | .60 | 3327A | 830 | .40 | 70B | 876 | .25 | 197B | 824 | .40 |
| 3122A | 834 | .60 | 3332A | 833 | .20 | 71B | 876 | .12 | 198B | 824 | .50 |
| 3123A | 834 | .60 | 4012A | 874 | .60 | 72B | 876 | .25 | 199B | 846 | .75 |
| 3126A | 835 | .50 | 4038A | 874 | .60 | 74B | 876 | .15 | 200B | 824 | .75 |
| 3129A | 836 | .60 | 4039A | 874 | .60 | 75B | 876 | .12 | 201B | 824 | .75 |
| 3130A | 833 | .20 | 4041A | 837 | .40 | 77B | 831 | .15 | 202B | 824 | .75 |

| NO. | PAGE | PRICE | NO. | PAGE | PRICE | NO. | PAGE | PRICE | NO. | PAGE | PRICE |
|------------------|------|-------|--------|------|-------|------------------|------|-------|-----------------|------|-------|
| 203B | 843 | \$.60 | 273B | 868 | \$.45 | 2439C | 842 | \$.75 | 2943C | 842 | \$.25 |
| 204B | 843 | .60 | 275B | 868 | .50 | 2441C | 850 | .75 | 2945C | 859 | .25 |
| 205B | 843 | .50 | 276B | 853 | .40 | 2442C | 820 | .25 | 2948C | 850 | .20 |
| 206B | 844 | .50 | 278B | 827 | .40 | 2443C | 821 | .30 | 2950C | 850 | .25 |
| 207B | 844 | .75 | 3559B | 863 | .50 | 2444C | 823 | .50 | 2951C | 851 | .20 |
| 208B | 844 | .30 | 3846B | 872 | .30 | 2458C | 858 | .30 | 2968C | 821 | .40 |
| 209B | 843 | .50 | 3847B | 872 | .30 | 2460C | 833 | .25 | 2969C | 822 | .20 |
| 210B | 843 | .60 | | | | 2465C | 860 | .50 | Per dozen, 2.00 | | |
| 211B | 844 | .50 | 61C | 853 | .20 | 2466C | 853 | .50 | Two colors, .40 | | |
| 212B | 844 | .75 | 182C | 858 | .15 | 2470C | 857 | .60 | Per dozen, 4.00 | | |
| 213B | 826 | .75 | 236C | 828 | .10 | 2471C | 820 | .50 | 2970C | 831 | .50 |
| 214B | 826 | .60 | 338C | 876 | .18 | 2477C | 852 | 1.00 | 2971C | 828 | .25 |
| 215B | 826 | .75 | 341C | 876 | .18 | 2530C | 821 | .30 | 2974C | 842 | .35 |
| 216B | 826 | .75 | 370C | 876 | .18 | 2546C | 823 | 1.00 | 2976C | 842 | .50 |
| Two colors, 1.25 | | | 402C | 876 | .20 | 2554C | 823 | .50 | 2994C | 867 | .30 |
| 217B | 826 | .30 | 420C | 828 | .30 | 2559C | 823 | 1.00 | 2997C | 852 | .75 |
| 220B | 826 | .30 | 490C | 876 | .25 | 2563C | 823 | 1.25 | 2998C | 828 | .25 |
| 221B | 827 | .25 | 491C | 876 | .25 | 2567C | 823 | 2.00 | 3002½C | 828 | .15 |
| 222B | 827 | .40 | 514C | 872 | .05 | 2646C | 842 | .45 | 3023C | 821 | .25 |
| 223B | 826 | .50 | 515C | 872 | .05 | 2678C | 853 | .50 | 3024C | 867 | .60 |
| 224B | 827 | .60 | 516C | 872 | .06 | 2681C | 853 | .75 | 3030C | 828 | .30 |
| 225B | 827 | .50 | 517C | 872 | .06 | 2687C | 854 | .30 | 3031C | 828 | .30 |
| 226B | 826 | .75 | 518C | 872 | .08 | 2694C | 865 | .60 | 3034C | 847 | 1.00 |
| 227B | 826 | .40 | 519C | 872 | .08 | 2695C | 855 | .75 | 3037C | 855 | .50 |
| 228B | 827 | .75 | 520C | 872 | .10 | 2700C | 869 | 1.50 | 3038C | 855 | .60 |
| 229B | 826 | .40 | 521C | 872 | .10 | 2703C | 870 | 1.00 | 3051C | 851 | .60 |
| 230B | 826 | .60 | 522C | 872 | .12 | 2704C | 870 | .75 | 3054C | 862 | 1.00 |
| 231B | 827 | 1.00 | 523C | 872 | .12 | 2708C | 825 | 1.00 | 3055C | 862 | .40 |
| 232B | 827 | .50 | 524C | 872 | .15 | 2709C | 823 | .50 | 3060C | 861 | .40 |
| 233B | 826 | .50 | 525C | 872 | .15 | 2711C | 823 | .50 | 3062C | 861 | .30 |
| 234B | 827 | .50 | 1225C | 828 | .30 | 2712C | 822 | .75 | 3094C | 860 | .60 |
| 235B | 827 | .40 | 1733C | 856 | .50 | Two colors, 1.50 | | | 3095C | 869 | .50 |
| 236B | 827 | .40 | 1840C | 843 | .30 | 2713C | 822 | .75 | 3121C | 819 | 1.00 |
| 237B | 827 | .60 | 1856C | 856 | .50 | Two colors, 1.50 | | | 3123C | 819 | 1.00 |
| 238B | 827 | .50 | 1857C | 857 | .50 | 2727C | 821 | .25 | 3127C | 819 | 1.00 |
| 239B | 826 | .75 | 1863C | 823 | .35 | 2749C | 868 | .45 | 3128C | 819 | 1.00 |
| 240B | 827 | .40 | 2016C | 850 | .25 | 2749C | 868 | .45 | 3130C | 819 | 1.00 |
| 241B | 827 | .40 | 2042C | 867 | .50 | 2751C | 818 | 1.50 | 3131C | 819 | 1.00 |
| 242B | 827 | .40 | 2048C | 839 | .75 | With Seal, 2.00 | | | 3135C | 819 | 1.00 |
| 243B | 827 | .40 | 2070C | 857 | 2.00 | 2752C | 820 | .75 | 3137C | 819 | 1.00 |
| 244B | 827 | .75 | 2092C | 855 | .50 | 2775C | 818 | .75 | 3138C | 819 | 1.00 |
| 245B | 827 | .25 | 2134C | 867 | .25 | 2776C | 818 | .75 | 3140C | 819 | 1.00 |
| 246B | 838 | .30 | 2135C | 828 | .30 | 2778C | 818 | .75 | 3142C | 850 | .75 |
| 247B | 838 | .40 | 2165C | 860 | 1.00 | 2779C | 818 | .75 | 3143C | 847 | .75 |
| 248B | 838 | .75 | 2171C | 858 | .50 | 2780C | 818 | .75 | 3146C | 851 | .40 |
| 249B | 842 | .60 | 2197C | 851 | .75 | 2785C | 818 | .75 | 3153C | 847 | .60 |
| 250B | 842 | .50 | 2213C | 820 | 2.00 | 2807C | 865 | .75 | 3160C | 870 | 2.75 |
| 251B | 842 | .40 | 2213½C | 820 | 1.00 | 2817C | 857 | .50 | 3165C | 829 | .40 |
| 252B | 842 | .40 | 2240C | 818 | 1.00 | 2819C | 870 | 1.00 | 3166C | 828 | .40 |
| 253B | 842 | .50 | 2241C | 818 | 1.00 | 2825C | 870 | 1.25 | 3167C | 829 | .40 |
| 254B | 837 | .75 | 2244C | 823 | .50 | 2830C | 870 | 1.50 | 3168C | 828 | .40 |
| 255B | 841 | 1.50 | 2258C | 821 | 1.25 | 2835C | 870 | 3.50 | 3169C | 828 | .75 |
| 256B | 839 | .60 | 2285C | 867 | .40 | 2850C | 870 | 3.50 | 3170C | 828 | .40 |
| 257B | 837 | .40 | 2290½C | 823 | .75 | 2854C | 858 | .50 | 3171C | 828 | .30 |
| 258B | 844 | .50 | 2302C | 868 | .50 | 2857C | 870 | 2.50 | 3172C | 828 | .30 |
| 259B | 840 | .75 | 2309½C | 828 | .50 | 2872C | 820 | 1.75 | 3175C | 851 | .60 |
| 260B | 840 | .75 | 2312½C | 856 | .40 | 2873C | 820 | 2.50 | 3182C | 821 | .75 |
| 261B | 840 | .40 | 2317C | 851 | .50 | 2874C | 820 | 4.50 | 3183C | 821 | 1.25 |
| 262B | 844 | .50 | 2332C | 860 | .75 | 2875C | 820 | 10.00 | 3189C | 867 | .50 |
| 263B | 844 | .60 | 2356C | 858 | .50 | 2891C | 868 | .50 | 3190C | 867 | .60 |
| 264B | 842 | .40 | 2385C | 820 | .75 | 2898C | 858 | 1.25 | 3199C | 842 | .30 |
| 265B | 859 | 1.00 | 2395C | 851 | .20 | 2902C | 858 | .50 | 3201C | 867 | .90 |
| 266B | 842 | .50 | 2408C | 850 | 1.00 | 2904C | 825 | .40 | 3204C | 855 | .50 |
| 267B | 836 | .45 | 2418C | 865 | .50 | 2905C | 854 | .60 | 3207C | 870 | 5.50 |
| 268B | 840 | .75 | 2419C | 842 | .50 | 2906C | 854 | .50 | 3271C | 847 | .60 |
| 269B | 868 | .75 | 2425C | 853 | .30 | 2926C | 851 | 1.00 | 3272C | 847 | .50 |
| 270B | 868 | .75 | 2431C | 831 | .60 | 2929C | 863 | .75 | 3273C | 847 | .75 |
| 271B | 868 | .50 | 2432C | 830 | .50 | 2937C | 851 | .40 | 3276C | 864 | .50 |
| 272B | 868 | .35 | 2435C | 825 | 1.00 | 2941C | 850 | .20 | 3279C | 828 | .50 |
| | | | | | | 2942C | 850 | .20 | | | |

| NO. | PAGE | PRICE | NO. | PAGE | PRICE | NO. | PAGE | PRICE | NO. | PAGE | PRICE |
|-------|-------|--------|-------------------|-------|--------|--------------------|-------|--------|-------------------|-------|--------|
| 3280C | . 847 | \$.040 | 3558C | . 875 | \$.030 | 3982C | . 852 | \$.030 | 4096C | . 850 | \$.125 |
| 3288C | . 855 | . 50 | 3559C | . 875 | . 50 | 3986C | . 873 | . 25 | 4099C | . 863 | 1.00 |
| 3289C | . 851 | . 30 | 3620C | . 835 | . 75 | Set of Eight, 1.75 | | | 4100C | . 869 | . 75 |
| 3290C | . 847 | . 50 | 3653C | . 828 | . 30 | 3987C | . 873 | . 25 | 4101C | . 869 | . 75 |
| 3293C | . 842 | . 30 | 3654C | . 831 | . 40 | Set of Eight, 1.75 | | | 4103C | . 867 | . 75 |
| 3298C | . 867 | . 40 | 3655C | . 828 | . 30 | 3988C | . 873 | . 25 | 4104C | . 869 | . 75 |
| 3354C | . 829 | . 35 | 3657C | . 836 | . 40 | Set of Eight, 1.75 | | | 4105C | . 868 | . 75 |
| 3355C | . 829 | . 35 | 3658C | . 836 | . 30 | 3989C | . 873 | . 25 | 4106C | . 868 | . 75 |
| 3356C | . 829 | . 40 | 3659C | . 839 | . 30 | Set of Eight, 1.75 | | | 4118C | . 868 | . 75 |
| 3357C | . 829 | . 35 | 3661C | . 838 | . 30 | 3990C | . 873 | . 25 | 4119C | . 853 | . 75 |
| 3358C | . 829 | . 25 | 3662C | . 835 | . 30 | Set of Eight, 1.75 | | | 4120C | . 842 | . 75 |
| 3359C | . 828 | . 25 | 3669C | . 870 | . 60 | 3991C | . 873 | . 25 | 4121C | . 838 | . 40 |
| 3360C | . 829 | 1.50 | 3674C | . 859 | . 75 | Set of Eight, 1.75 | | | 4122C | . 838 | . 40 |
| 3361C | . 828 | . 50 | 3677C | . 859 | . 75 | 3992C | . 873 | . 25 | 4123C | . 838 | . 60 |
| 3362C | . 828 | . 30 | 3679C | . 870 | 1.00 | Set of Eight, 1.75 | | | 4124C | . 838 | . 75 |
| 3363C | . 829 | . 30 | 3682C | . 831 | . 50 | 3993C | . 873 | . 25 | 4125C | . 824 | . 30 |
| 3364C | . 829 | . 30 | 3683C | . 835 | . 50 | Set of Eight, 1.75 | | | 4127C | . 859 | . 60 |
| 3365C | . 829 | . 35 | 3685C | . 839 | . 50 | 3995C | . 859 | . 60 | 4129C | . 870 | . 30 |
| 3370C | . 855 | . 50 | 3709C | . 875 | . 25 | 3996C | . 837 | . 75 | 4130C | . 870 | . 35 |
| 3372C | . 828 | . 35 | 3711C | . 843 | . 35 | 3997C | . 864 | . 75 | 4131C | . 870 | . 40 |
| 3378C | . 855 | . 40 | 3712C | . 867 | . 40 | 3998C | . 823 | . 75 | Mortised, .70 | | |
| 3380C | . 857 | . 50 | 3756C | . 860 | . 75 | 3999C | . 823 | 1.00 | 4140C | . 830 | . 75 |
| 3383C | . 829 | . 35 | 3778C | . 825 | 1.00 | 4000C | . 823 | 1.25 | 4141C | . 825 | . 60 |
| 3384C | . 829 | 1.50 | 3779C | . 825 | . 60 | 4037C | . 873 | . 35 | 4144C | . 838 | . 50 |
| 3386C | . 861 | 1.00 | 3780C | . 820 | . 75 | Set of Eight, 2.50 | | | 4148C | . 825 | . 40 |
| 3388C | . 854 | . 75 | 3781C | . 821 | . 75 | 4038C | . 873 | . 35 | 4149C | . 825 | . 35 |
| 3393C | . 832 | . 60 | 3784C | . 847 | . 50 | Set of Eight, 2.50 | | | 4150C | . 869 | . 50 |
| 3394C | . 832 | . 60 | 3785C | . 854 | . 60 | 4039C | . 873 | . 35 | 4152C | . 826 | . 40 |
| 3395C | . 832 | . 60 | 3786C | . 859 | . 30 | Set of Eight, 2.50 | | | 4153C | . 826 | . 30 |
| 3396C | . 832 | . 60 | 3787C | . 849 | . 70 | 4040C | . 873 | . 35 | 4167C | . 858 | . 40 |
| 3397C | . 832 | . 60 | 3788C | . 870 | . 75 | Set of Eight, 2.50 | | | 4168C | . 858 | . 60 |
| 3398C | . 832 | . 60 | 3790C | . 835 | . 75 | 4041C | . 873 | . 35 | 4176C | . 848 | |
| 3399C | . 830 | . 40 | 3791C | . 864 | . 75 | Set of Eight, 2.50 | | | Per set, 2.00 | | |
| 3400C | . 830 | . 40 | 3792C | . 867 | . 75 | 4042C | . 873 | . 35 | 4178C | . 848 | |
| 3401C | . 830 | . 40 | 3794C | . 850 | . 50 | Set of Eight, 2.50 | | | Per set, 2.00 | | |
| 3402C | . 830 | . 40 | 3795C | . 850 | . 75 | 4043C | . 873 | . 35 | 4179C | . 848 | |
| 3403C | . 830 | . 40 | 3796C | . 850 | 1.00 | Set of Eight, 2.50 | | | Per set, 1.00 | | |
| 3404C | . 830 | . 40 | 3800C | . 862 | . 30 | 4044C | . 873 | . 35 | 4181C | . 848 | 1.75 |
| 3407C | . 828 | . 60 | 3816C | . 863 | 1.00 | Set of Eight, 2.50 | | | 4185C | . 843 | . 50 |
| 3409C | . 851 | . 60 | 3818C | . 825 | . 75 | 4045C | . 873 | . 50 | 4186C | . 854 | . 50 |
| 3410C | . 853 | . 75 | 3852C | . 875 | . 60 | Set of Eight, 3.50 | | | 4188C | . 854 | . 50 |
| 3417C | . 835 | . 25 | 3866C | . 875 | . 60 | 4046C | . 873 | . 50 | 4201C | . 871 | . 50 |
| 3418C | . 835 | . 50 | 3867C | . 875 | . 50 | Set of Eight, 3.50 | | | 4205C | . 871 | . 50 |
| 3419C | . 835 | . 60 | 3872C | . 875 | . 60 | 4047C | . 873 | . 50 | 4209C | . 871 | . 50 |
| 3426C | . 852 | . 60 | 3878C | . 875 | . 75 | Set of Eight, 3.50 | | | 4211C | . 871 | . 50 |
| 3432C | . 870 | . 40 | 3881C | . 875 | . 75 | 4048C | . 873 | . 50 | 5089C | . 869 | . 60 |
| 3434C | . 856 | 1.50 | 3885C | . 875 | . 40 | Set of Eight, 3.50 | | | Four colors, 2.00 | | |
| 3436C | . 855 | . 50 | 3886C | . 875 | . 30 | 4049C | . 873 | . 50 | 5091C | . 849 | . 60 |
| 3438C | . 850 | . 40 | 3887C | . 875 | . 30 | Set of Eight, 3.50 | | | 5096C | . 849 | . 50 |
| 3440C | . 870 | . 75 | 3902C | . 875 | . 75 | 4050C | . 873 | . 50 | 5097C | . 849 | . 60 |
| 3445C | . 851 | . 40 | 3904C | . 875 | . 75 | Set of Eight, 3.50 | | | 5098C | . 849 | . 35 |
| 3450C | . 856 | 1.50 | 3929C | . 820 | 1.25 | 4051C | . 873 | . 50 | 5099C | . 849 | . 60 |
| 3451C | . 854 | . 50 | 3938C | . 825 | . 75 | Set of Eight, 3.50 | | | 5100C | . 849 | . 40 |
| 3453C | . 821 | . 90 | 3941C | . 865 | . 60 | 4052C | . 873 | . 50 | 5107C | . 823 | 1.25 |
| 3454C | . 831 | . 75 | 3944C | . 851 | . 25 | Set of Eight, 3.50 | | | 5108C | . 823 | 1.00 |
| 3455C | . 828 | . 40 | Per dozen, 2.00 | | | 4053C | . 873 | . 50 | 5109C | . 823 | . 75 |
| 3456C | . 857 | . 50 | 3945C | . 833 | . 25 | 4054C | . 866 | . 75 | 5111C | . 823 | . 75 |
| 3460C | . 821 | . 25 | 3948C | . 851 | . 75 | 4056C | . 866 | . 75 | 5112C | . 823 | 1.25 |
| 3462C | . 853 | . 75 | 3949C | . 851 | . 50 | 4058C | . 866 | . 75 | 5114C | . 823 | 1.00 |
| 3466C | . 865 | . 50 | 3952C | . 824 | 1.00 | 4059C | . 866 | . 75 | 5123C | . 823 | . 50 |
| 3476C | . 850 | . 60 | 3953C | . 824 | . 75 | 4060C | . 866 | . 60 | 5127C | . 822 | 3.50 |
| 3484C | . 870 | 1.00 | Four colors, 2.50 | | | 4065C | . 866 | . 75 | 5127½C | . 822 | 2.25 |
| 3490C | . 839 | 1.75 | 3954C | . 852 | . 50 | 4066C | . 866 | . 75 | 5142C | . 822 | 1.25 |
| 3501C | . 875 | . 75 | 3955C | . 824 | . 60 | 4069C | . 866 | . 75 | 5143C | . 822 | 2.00 |
| 3503C | . 875 | . 75 | 3957C | . 854 | . 40 | 4070C | . 866 | . 60 | 5144C | . 822 | 1.50 |
| 3512C | . 875 | . 50 | 3958C | . 871 | . 90 | 4071C | . 866 | . 75 | 5145C | . 822 | 2.50 |
| 3535C | . 875 | . 50 | 3968C | . 871 | . 90 | 4092C | . 858 | . 60 | 5160C | . 849 | . 75 |
| 3536C | . 875 | . 40 | 3970C | . 831 | . 50 | 4093C | . 858 | 1.25 | 5162C | . 849 | 1.00 |
| 3540C | . 875 | . 40 | 3972C | . 836 | . 60 | 4095C | . 825 | . 35 | 5163C | . 849 | . 75 |

| NO. | PAGE | PRICE | NO. | PAGE | PRICE | NO. | PAGE | PRICE | NO. | PAGE | PRICE |
|---------|------|-------|-------|------|-------|-------|------|-------|-----------------|------|-------|
| 5,164C | .849 | \$.60 | 511E | .876 | \$.12 | 2024E | .840 | \$.40 | 1264F | .836 | \$.60 |
| 12,134C | .823 | .35 | 514E | .820 | .25 | 2025E | .841 | .40 | 1266F | .836 | .75 |
| 12,137C | .823 | .60 | 524E | .876 | .15 | 2026E | .841 | .60 | 1268F | .841 | .60 |
| 12,167C | .844 | .40 | 532E | .853 | .25 | 2028E | .841 | .75 | 1273F | .844 | .50 |
| 12,173C | .854 | .40 | 600E | .876 | .20 | 2029E | .846 | .60 | 1275F | .835 | .75 |
| 12,176C | .853 | .60 | 604E | .876 | .15 | 2032E | .870 | .40 | 1277F | .841 | .35 |
| 12,177C | .853 | .40 | 606E | .876 | .15 | 2033E | .852 | 1.00 | 1285F | .844 | .60 |
| 12,178C | .853 | .40 | 608E | .876 | .20 | 2034E | .852 | .60 | 1301F | .840 | .40 |
| 12,180C | .851 | .40 | 616E | .860 | .15 | 2036E | .852 | .40 | 1324F | .841 | .50 |
| 1294D | .869 | .60 | 652E | .867 | .20 | 2037E | .852 | .50 | 1327F | .833 | .50 |
| 1386D | .859 | .50 | 672E | .859 | .25 | 2038E | .852 | .25 | 1328F | .839 | .60 |
| 1602D | .861 | .35 | 700E | .853 | .30 | 2039E | .852 | .35 | 1329F | .835 | .50 |
| 1603D | .861 | .35 | 707E | .876 | .20 | 2040E | .852 | .25 | 1331F | .837 | .40 |
| 1604D | .861 | .35 | 709E | .860 | .25 | 2042E | .852 | .40 | 1336F | .837 | .50 |
| 1605D | .861 | .35 | 711E | .860 | .25 | 2045E | .853 | .30 | 1343F | .846 | .60 |
| 1606D | .861 | .35 | 716E | .833 | .20 | 2046E | .863 | .75 | 1344F | .841 | .60 |
| 1607D | .861 | .35 | 717E | .858 | .25 | 2047E | .863 | .75 | 1361F | .836 | .50 |
| 1608D | .861 | .35 | 728E | .876 | .15 | 2048E | .862 | 2.00 | 1381F | .840 | .40 |
| 1609D | .861 | .35 | 731E | .860 | .25 | 2049E | .861 | .75 | 2527F | .876 | .15 |
| 1610D | .861 | .35 | 732E | .856 | .25 | 2050E | .860 | .75 | 2657F | .860 | .20 |
| 1611D | .861 | .35 | 734E | .876 | .15 | 2051E | .860 | .60 | 2658F | .855 | .25 |
| 1612D | .861 | .35 | 735E | .876 | .15 | 2052E | .855 | .75 | 2660F | .860 | .25 |
| 1613D | .861 | .35 | 736E | .876 | .15 | 2053E | .861 | .75 | 2662F | .859 | .25 |
| 1629D | .856 | .60 | 743E | .854 | .20 | 2054E | .855 | .75 | 4001F | .872 | .05 |
| 1744D | .852 | .35 | 744E | .854 | .25 | 2055E | .855 | .75 | 4002F | .872 | .05 |
| 1796D | .856 | .35 | 748E | .876 | .20 | 2056E | .856 | .30 | 4003F | .872 | .05 |
| 1824D | .852 | .75 | 803E | .821 | .25 | 2057E | .856 | 1.00 | 4004F | .872 | .05 |
| 1870D | .847 | .25 | 804E | .855 | .25 | 2058E | .864 | .75 | 4005F | .872 | .05 |
| 1871D | .847 | .30 | 850E | .859 | .30 | 2059E | .864 | 1.50 | 4006F | .872 | .05 |
| 1872D | .847 | .50 | 852E | .876 | .20 | 2061E | .864 | .75 | 4007F | .872 | .10 |
| 1873D | .847 | .50 | 857E | .820 | .25 | 2062E | .864 | .75 | 4008F | .872 | .10 |
| 1874D | .847 | .60 | 859E | .863 | .30 | 2063E | .857 | .40 | 4009F | .872 | .10 |
| 1875D | .847 | .75 | 865E | .853 | .25 | 2064E | .857 | 1.00 | 4010F | .872 | .10 |
| 1876D | .847 | 1.50 | 868E | .853 | .30 | 2066E | .857 | .50 | 4011F | .872 | .10 |
| 1877D | .847 | 2.00 | 869E | .833 | .30 | 2067E | .839 | .60 | 4012F | .872 | .10 |
| 2253D | .869 | .60 | 901E | .833 | .25 | 2068E | .865 | 1.00 | 4013F | .872 | .15 |
| 3932D | .869 | .75 | 902E | .840 | .30 | 2069E | .865 | .75 | 4014F | .872 | .15 |
| 10,332D | .854 | .60 | 903E | .838 | .30 | 2071E | .865 | 1.00 | 4015F | .872 | .20 |
| 11E | .876 | .08 | 904E | .833 | .30 | 2072E | .865 | .75 | 4016F | .872 | .20 |
| 117E | .876 | .12 | 916E | .832 | .30 | 2074E | .859 | .60 | 4017F | .872 | .25 |
| 119E | .876 | .10 | 917E | .860 | .30 | 2075E | .859 | 1.00 | 4018F | .872 | .25 |
| 124E | .876 | .15 | 1052E | .872 | .08 | 2076E | .849 | .40 | 4020F | .854 | .20 |
| 255E | .876 | .12 | 1053E | .872 | .08 | 2077E | .828 | .50 | 4042F | .862 | .20 |
| 314E | .876 | .10 | 1070E | .872 | .15 | 2078E | .829 | 1.00 | Per dozen, 2.00 | | |
| 353E | .876 | .08 | 1071E | .872 | .15 | 2079E | .829 | .75 | 4957F | .858 | .20 |
| 404E | .876 | .08 | 1072E | .872 | .12 | 2080E | .828 | .35 | 4065F | .860 | .20 |
| 409E | .876 | .08 | 1073E | .872 | .12 | 2081E | .829 | .50 | 4099F | .862 | .30 |
| 412E | .876 | .10 | 1074E | .872 | .20 | 2090E | .859 | .40 | Per dozen, 2.50 | | |
| 428E | .830 | .20 | 1075E | .872 | .20 | 1109F | .824 | .75 | 4105F | .876 | .30 |
| 431E | .876 | .12 | 1078E | .872 | .30 | 1161F | .834 | .35 | 4110F | .840 | .25 |
| 435E | .876 | .15 | 1079E | .872 | .30 | 1204F | .838 | .75 | 4115F | .853 | .30 |
| 436E | .853 | .20 | 1274E | .839 | .40 | 1207F | .838 | .50 | 4122F | .854 | .30 |
| 437E | .876 | .15 | 1341E | .841 | .40 | 1208F | .841 | .40 | 4123F | .854 | .35 |
| 450E | .876 | .20 | 2007E | .840 | .75 | 1211F | .835 | .35 | 4124F | .854 | .30 |
| 455E | .853 | .20 | 2011E | .840 | .60 | 1213F | .833 | .50 | 4125F | .854 | .30 |
| 464E | .857 | .20 | 2013E | .832 | .60 | 1214F | .832 | .60 | 4126F | .854 | .40 |
| 465E | .857 | .15 | 2014E | .833 | 1.25 | 1220F | .831 | .50 | 4129F | .858 | .30 |
| 466E | .858 | .15 | 2015E | .834 | .60 | 1232F | .835 | .40 | 4149F | .863 | .40 |
| 468E | .854 | .20 | 2016E | .835 | .50 | 1238F | .837 | .75 | Per dozen, 4.00 | | |
| 501E | .876 | .12 | 2018E | .837 | 1.00 | 1258F | .841 | .50 | 7048H | .841 | .60 |
| 507E | .853 | .25 | 2022E | .824 | .75 | 1262F | .836 | .50 | 7049H | .841 | .75 |
| | | | 2023E | .839 | .60 | | | | | | |

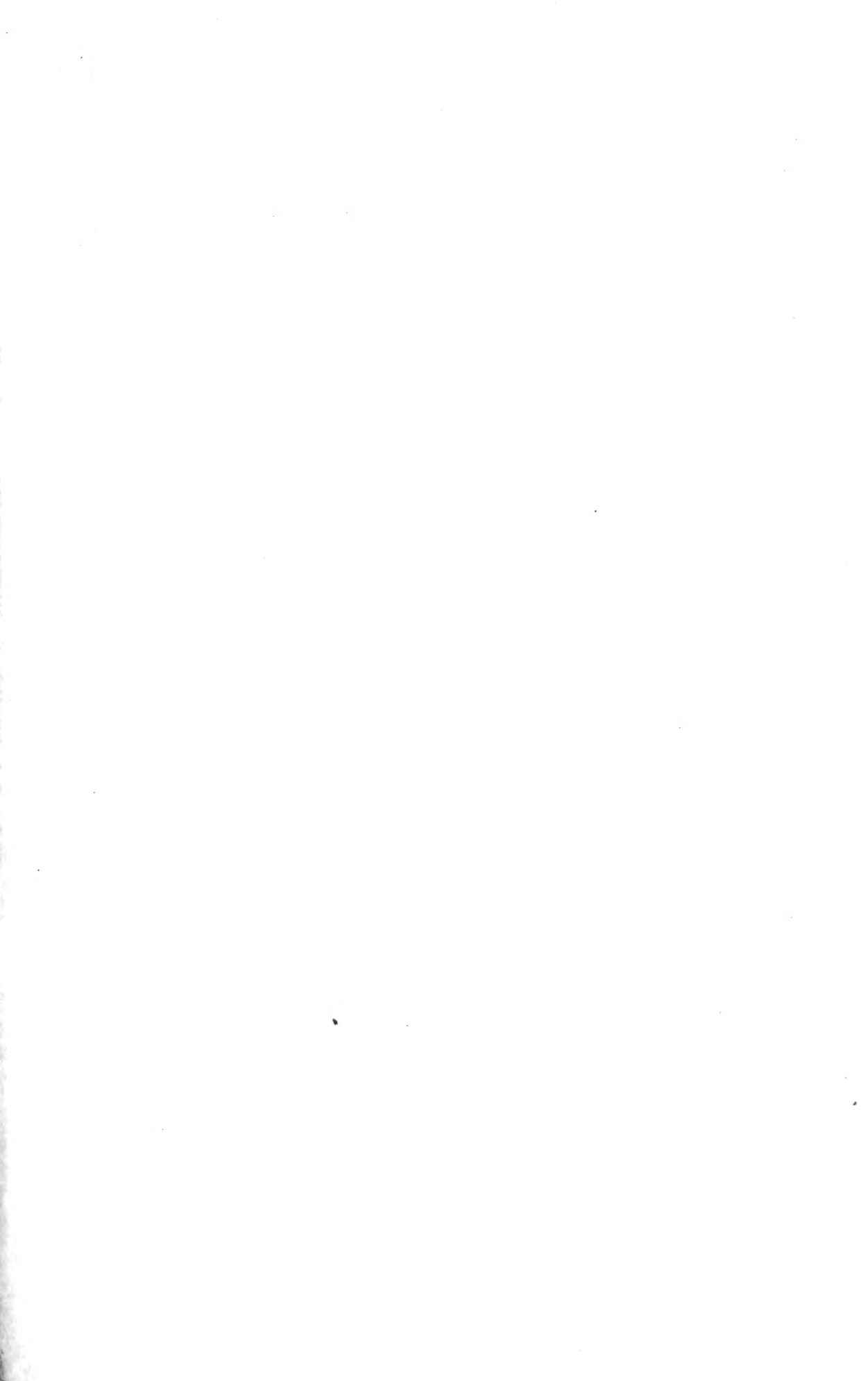



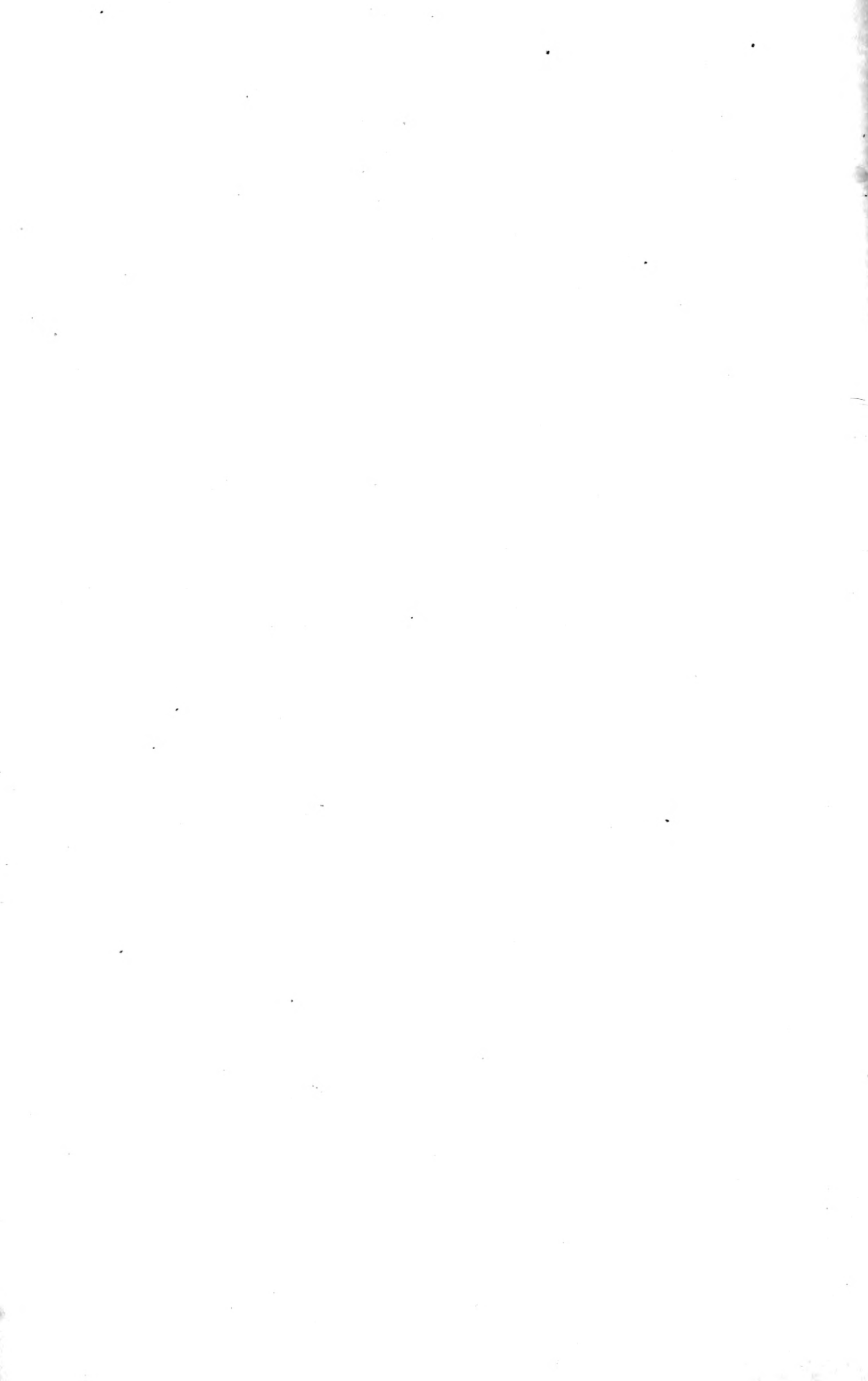



No. 25. 70 cts.



No. 23. 70 cts.

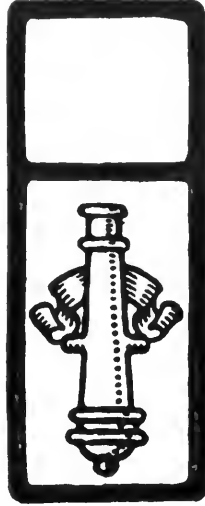

No. 31. 70 cts.



No. 35. 70 cts.



No. 45. 60 cts.



No. 48. 60 cts.



No. 46. 60 cts.



No. 47. 60 cts.



No. 56. 70 cts.



No. 43. 60 cts.



No. 50. 60 cts.



No. 42. 60 cts.

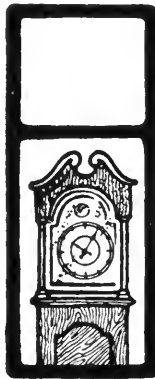

No. 41. 60 cts.

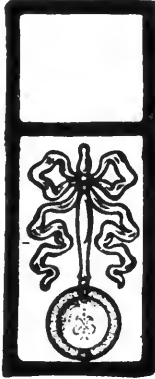

No. 53. 60 cts.



No. 55. 60 cts.



No. 52. 60 cts.



No. 49. 60 cts.



No. 54. 60 cts.



No. 51. 60 cts.



No. cts.

MORTISED INITIAL ORNAMENTS

These Mortised Ornaments are electrotypes blocked on kiln-dried cherry wood. They are accurately mortised to allow the insertion of a letter. Order by Name and No.



No. 11. 80 cts.



No. 9. 80 cts.



No. 1. 80 cts.



No. 2. 80 cts.



No. 36. 70 cts.



No. 34. 70 cts.



No. 29. 70 cts.



No. 32. 70 cts.

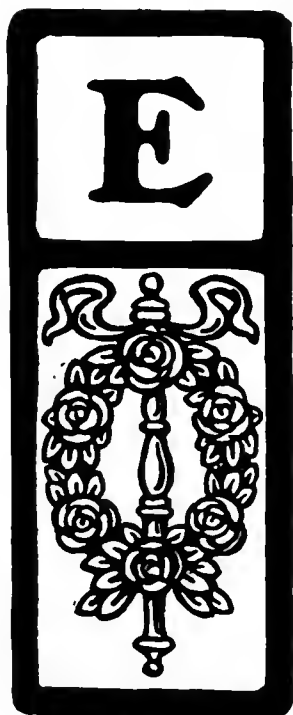

No. 12. 80 cts.



No. 3. 80 cts.



No. 10. 80 cts.



No. 16. 80 cts.



No. 22. 70 cts.



No. 21. 70 cts.



No. 27. 70 cts.

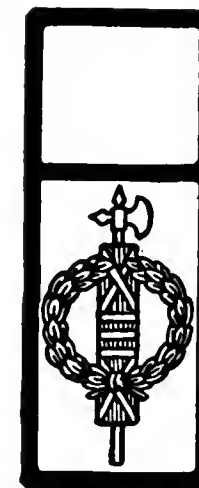

No. 28. 70 cts.

SIZE OF MORTISE,
FROM RULE TO RULE

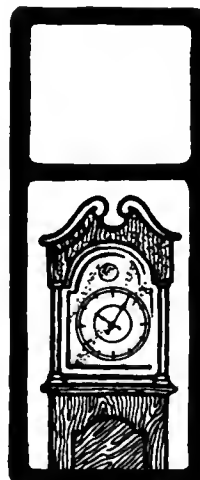

No. 30. 70 cts.

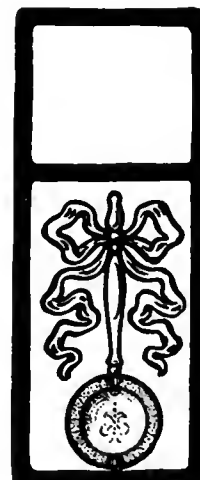

No. 33. 70 cts.

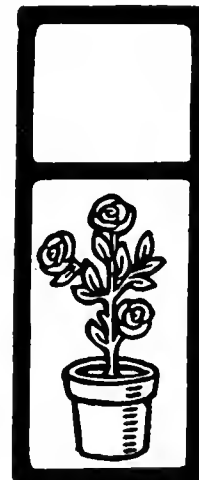

No. 24. 70 cts.



No. 26. 70 cts.

MORTISED INITIAL ORNAMENTS

These Mortised Ornaments are electrotypes blocked on kiln-dried cherry wood. They are accurately mortised to allow the insertion of a letter. Order by Name and No.

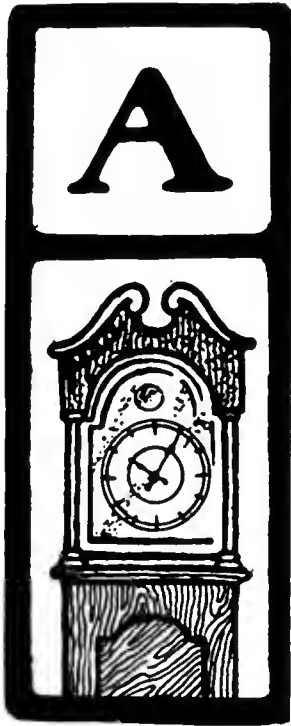

No. 6. 80 cts.

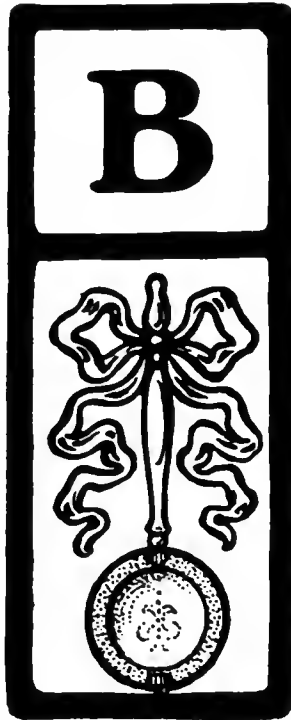

No. 4. 80 cts.

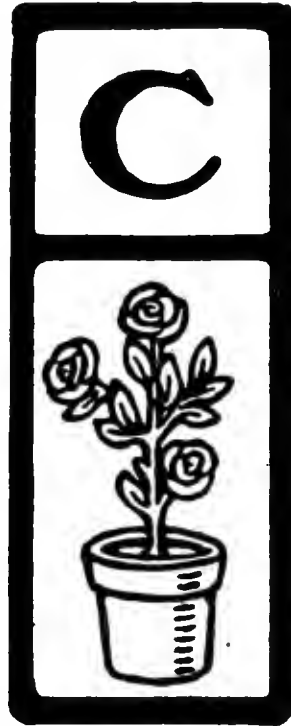

No. 13. 80 cts.



No. 7. 80 cts.



No. 8. 80 cts.

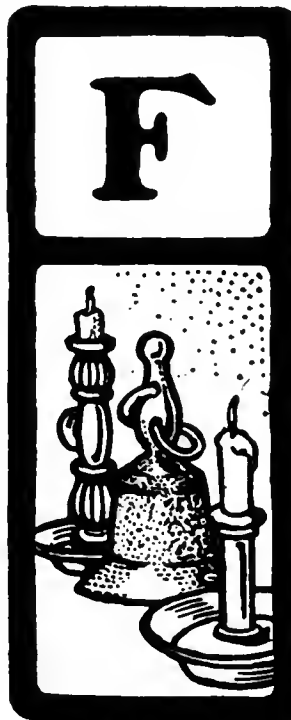

No. 5. 80 cts.

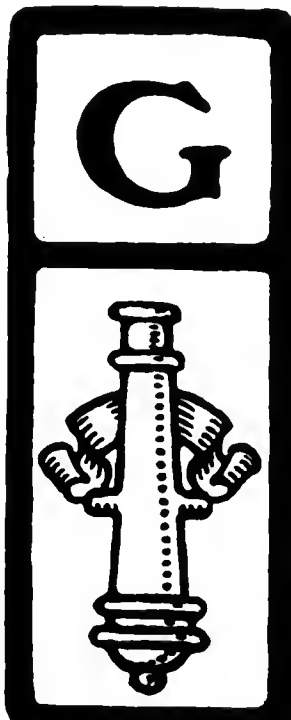

No. 14. 80 cts.

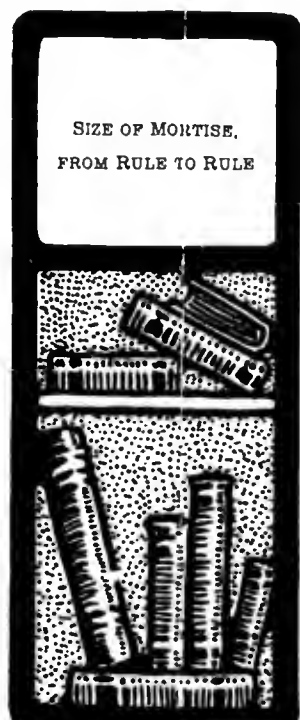

No. 15. 80 cts.



No. 25. 70 cts.



No. 23. 70 cts.



No. 31. 70 cts.



No. 35. 70 cts.



No. 45. 60 cts.



No. 48. 60 cts.



No. 46. 60 cts.

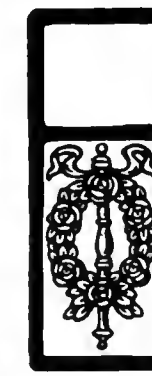

No. 47. 60 cts.



No. 56. 70 cts.



No. 43. 60 cts.



No. 50. 60 cts.



No. 42. 60 cts.

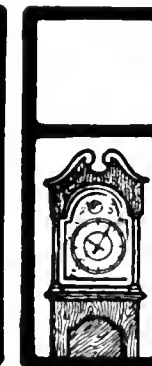

No. 41. 60 cts.



No. 53. 60 cts.



No. 55. 60 cts.



No. 52. 60 cts.



No. 49. 60 cts.



No. 54. 60 cts.



No. 51. 60 cts.



No. 44. 60 cts.

SIZE OF MORTISE,
FROM RULE TO RULE

MORTISED INITIAL ORNAMENTS

These Mortised Ornaments are electrotypes blocked on kiln-dried cherry wood. They are accurately mortised to allow the insertion of a letter. Order by Name and No.

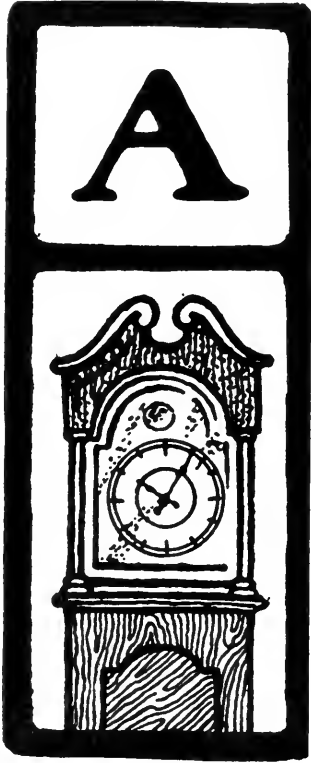

No. 6. 80 cts.

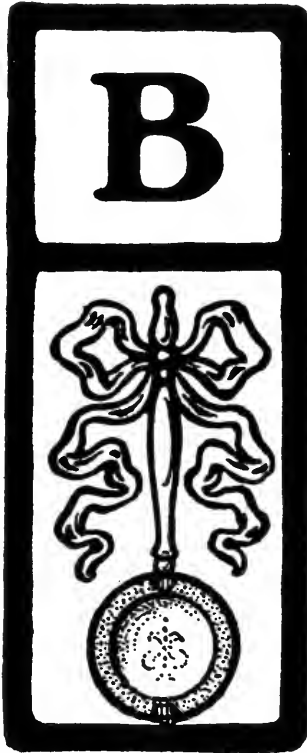

No. 4. 80 cts.

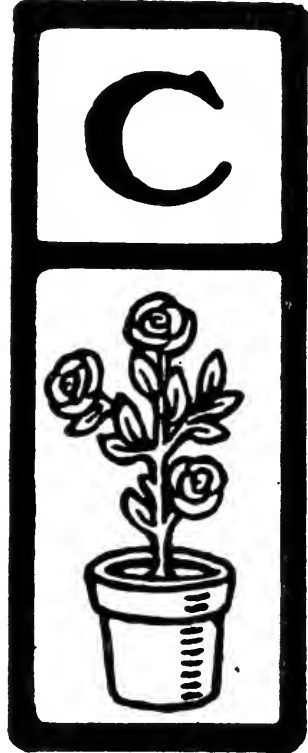

No. 13. 80 cts.



No. 7.



No. 8. 80 cts.



No. 5. 80 cts.

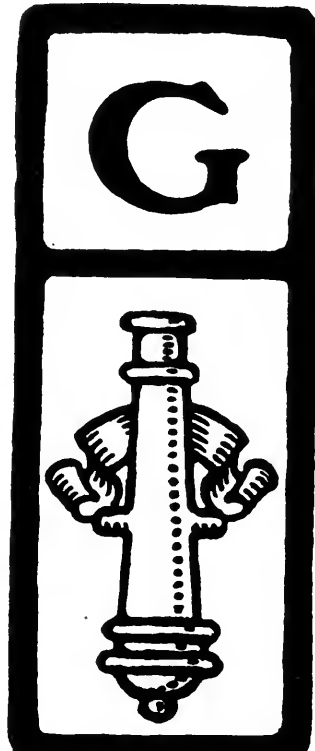

No. 14. 80 cts.



No. 15.

SIZE OF
FROM RUL



DATE DUE

| | |
|------------------------|---------------------------------------|
| OCT 23 1998 | |
| JUN 0 1998 | FEB 22 2006 |
| JUN 15 1998 | MAY 2 2003 |
| FEB 16 1999 | SEP 06 2007 SEP 04 2007 |
| APR 27 1999 | JUL 28 2008 |
| FEB 13 2002 | AUG 29 2009 |
| NOV 30 2002 | JAN 16 2009 |
| MAY 28 2003 | JAN 08 2009 |
| DEC 02 2003 | OCT 06 2009 |
| DEC 16 2003 | MAR 08 2011 |
| APR 01 2004 | APR 07 2011 |
| APR 01 2004 | |
| APR 21 2005 | |
| DEC 1 2004 | |
| MAR 22 2005 | |
| MAR 02 2005 | |
| FEB 11 2005 | |



31197 11918 0831

BRIGHAM YOUNG UNIVERSITY

2000

BRM
2-95

